

U.S. Department of Labor
Mine Safety and Health Administration

ENGINEERING AND DESIGN MANUAL

COAL REFUSE DISPOSAL FACILITIES



Second Edition
May 2009

NOTE: Instructions for using this DVD version of the Manual are provided on the next page

INSTRUCTIONS FOR USAGE OF THIS DVD MANUAL

This DVD requires Adobe Reader 7.0 or later. Other PDF viewing software may limit functionality. Adobe Reader can be downloaded at <http://get.adobe.com/reader/>

Bookmarks are provided for the Manual chapters, appendices and the reference list and are displayed at the left of the text.

Links in the Manual text in BLUE will transfer you to another location in the Manual such as a section header, figure or table. If you wish to return to the original link location, you can hold down the ALT key and hit the left arrow (←) key. On Mac computers hold down the Command key (⌘) and hit the left arrow key. If you move around at the new location in the text, you may have to repeat this action several times to return to your origination point. At the center of the bottom of most pages there is a PREVIOUS VIEW link. Clicking on this link will return you to your previous location in the document IF (and only if) you have not scrolled or otherwise moved away from the original landing location. Hitting the left arrow key without holding down the ALT key will move you back one (1) page only.

The Table of Contents (TOC) listings are linked to the appropriate pages in the Manual text. Clicking on a specific section header in the TOC will land you on the page where the section header is located in the text. It is recommended that whole pages be displayed when clicking on the TOC links because the section header that you are looking for may not be displayed on your monitor if the page is “zoomed up” so that only part of the page is displayed. When you find the section you are looking for, you can zoom to a comfortable reading size.

Links in GREEN will transfer you to technical references. Some of these are large documents and may require a few seconds to load. These documents are in PDF format and are stored on the DVD. You can return to the link in the Manual text by holding down the ALT key and hitting the left arrow (←) key. On Mac computers hold down the Command key (⌘) and hit the left arrow key. The more you move around in the reference document, the more times you will have to execute ALT + left arrow or ⌘ + left arrow. If you use the reference document extensively, you may not be able to link back to the Manual in this manner, and then it will be necessary to close the reference document in Adobe Reader and then go to the File > History list and reopen Manual 2009. This procedure will return you to the Manual title page and not to the page where you linked from previously. Reference documents can be opened in a new window by holding down the CTRL key when clicking on reference links, and we recommend this procedure. On Mac computers hold down the Option key (⌥) when clicking the link.

If you load the Manual PDF to your computer, the references should be loaded to the same folder.

Suggestions for changes, corrections, or updates to the Manual should be directed to:

Mine Safety and Health Administration
Pittsburgh Technical Support Center
Mine Waste and Geotechnical Engineering Division
P.O. Box 18233
Pittsburgh, PA 15236
Attention: Dam Safety Officer

The engineering guidance presented in this document has been compiled or developed by D’Appolonia Engineering under contract with the Mine Safety and Health Administration (MSHA) from referenced sources as well as input from MSHA and the coal industry. However, the guidance, recommendations, and conclusions presented herein may not necessarily represent the official policies of MSHA or the U.S. government.

Preface

This Manual presents guidance on procedures for use in the engineering design, construction monitoring, operation and inspection of coal refuse impoundments and embankments in the United States. It is an update of the original 1975 edition and reflects advances in engineering, construction, and facility monitoring and operations practices. The primary intent of the Manual is to serve as a uniform guide to safe refuse disposal practices for those concerned with coal mining and preparation. The Manual serves this purpose in several ways by: (1) providing experienced embankment dam design engineers with the characteristics of coal refuse and its disposal so that their experience can be appropriately applied; (2) providing specialized technical knowledge concerning embankment design in a form that can be used by engineers who do not specialize in this field; (3) updating geotechnical, structural, hydrologic and hydraulic design criteria for a range of embankment and impoundment conditions, and spillway and drainage structures; (4) providing guidance on disposal requirements and limitations for mine operators to include refuse disposal in the overall coal production operation; and (5) providing guidance on construction, operation, inspection, monitoring and instrumentation, and emergency action planning associated with the implementation of safe and reliable designs.

The 1975 edition of the Manual was prepared following the failure of a coal waste dam at Buffalo Creek, West Virginia, that resulted in 125 fatalities. This Manual update was prompted by the recognition that significant advances have been made in the fields of coal waste disposal and dam safety in the 30-plus years since the original Manual was published. Another impetus was an incident that occurred in Martin County, Kentucky, in 2000 in which over 300 million gallons of water and fine coal refuse from a slurry impoundment broke into an underground mine. Slurry subsequently flowed out of two mine openings and impacted streams in two separate watersheds. This incident prompted the U.S. Congress to provide funding to the National Research Council (NRC) to examine ways to reduce the potential for similar accidents. The NRC's report, "Coal Waste Impoundments: Risks, Responses, and Alternatives," which was released in 2002, included a number of recommendations for MSHA. One recommendation was that MSHA "continue to adopt and promote the best available technology and practices with regard to site evaluation, design, construction, and operation of impoundments." MSHA reported to Congress that one measure to address the NRC recommendations would be this updating of the original Coal Refuse Design Manual.

The guidance presented in this Manual represents information, methods and procedures that are recommended for consideration by designers, coal operators, and regulators. The guidance presented in this Manual is not regulation and cannot be enforced as such. It is not intended to preclude the application of other credible methods and procedures or the use of other and new information that will result in a safe and reliable coal refuse disposal facility. It is the responsibility of the designer to investigate the requirements of the project, recognize the unique and critical aspects of the site conditions, and prepare designs that reflect actual site conditions, features, loadings, and constraints.

In this update of the Manual, new chapters have been developed on seismic design and on site mining and foundation issues, two topics that can have an impact on the type of disposal facility designed. The long operating life of coal refuse facilities makes monitoring of embankment behavior and facility maintenance particularly important. The sections on operation, monitoring, and instrumentation summarize procedures and devices to aid the designer and operator for defining and implementing an appropriate field observation program. In addition, general guidance is provided for the preparation of emergency action plans. These plans are recommended for certain dams and impoundments, and are required by some state regulatory agencies and encouraged by MSHA as part of addressing hazardous conditions under 30 CFR § 77.216-3.

In addition to concern for safety, the Manual addresses environmental considerations and controls that may influence the design of embankments and impoundments. Executive Order 11514 – Protection and Enhancement of Environmental Quality, dated March 5, 1970, requires all Federal agencies to “Monitor, evaluate and control on a continuing basis their agencies’ activities so as to protect and enhance the quality of the environment. Such activities shall include those directed to controlling pollution and enhancing the environment and those designed to accomplish other program objectives which may affect the quality of the environment.” The Manual does not present guidance in establishing criteria for environmental controls (e.g., hydraulic conductivity of liner systems), because such guidance is more appropriately left to other references and regulatory agencies.

This Manual is intended to provide the designer with an important source of information. However, the text and accompanying figures, tables and references should not be applied without proper engineering knowledge and judgment. Responsibility for actual design lies with the Professional Engineer in responsible charge of the work. The use or application of the methods and information contained herein is strictly the responsibility of the person utilizing the material. Designs should be based on sound engineering principles and judgment and reflect actual site conditions, and they should not merely be patterned after a successful design used at another location or possibly portrayed in the Manual. The designer should be diligent and recognize that advances in approaches, criteria, and methods will occur that may affect the applicability of portions of any reference or design guide.

This Manual was prepared by engineers and scientists with background and experience in the subject matter, with input from MSHA personnel who review design plans and conduct investigations at disposal sites. Overall direction and technical content were provided by Mr. Robert E. Snow of D’Appolonia Engineering. Manual coordination was performed by Dr. James L. Withiam, D’Appolonia, and final editing of the text was provided by Dr. J. Timothy Onstott. Proper recognition to the entire Project Team and D’Appolonia staff for their devoted efforts is not possible here. The main contributors to and reviewers of technical chapters are noted in Table 1.

Special recognition is also given to Mr. John W. Fredland, Dam Safety Officer for MSHA, as the contracting officer’s technical representative, Mr. Harold L. Owens, Mr. George H. Gardner, and to other MSHA personnel who provided many valuable comments in suggesting content and reviewing the text for publication. Finally, grateful appreciation is given to those in industry who provided input and review comments during the process of preparation of this document. This includes input from the National Mining Association and its consultants, as well as federal and state agencies and universities.

This Manual is available in hard copy and DVD. The DVD format includes hyperlinks and search capabilities using Adobe Acrobat Reader software. Hyperlinks allow the display of the highlighted citation of a figure, table, appendix, or selected reference in the text. Selected references (in PDF format) that are available in the public domain are included on the DVD version. For references not in the public domain, reasonable efforts were made to obtain copyright permission. No hyperlink is provided for references of substantial size, lack of availability in the public domain, or where permission for reprint could not be obtained. The complete citation for all references is provided in the References section.

TABLE 1 MAJOR AND EXPERT CONTRIBUTORS AND REVIEWERS

<u>Chapters 1 to 5</u> Introduction, Background, Planning and Design Components	Mr. Robert E. Snow, D'Appolonia	Mr. Richard G. Almes
<u>Chapter 6</u> Geotechnical Exploration, Materials Testing, Engineering Analysis and Design	Dr. James L. Withiam, D'Appolonia Mr. William J. Johnson, D'Appolonia Mr. Joseph W. Premozic, D'Appolonia Mr. Christopher J. Lewis, D'Appolonia	Mr. Richard G. Almes Dr. Umesh Dayal
<u>Chapter 7</u> Seismic Design: Stability and Deformation Analyses	Mr. Michael Paster, GEI Mr. William J. Johnson, D'Appolonia Mr. Christopher J. Lewis, D'Appolonia Mr. Richard F. Tobin, GEI	Dr. Gonzalo Castro, GEI Dr. William F. Marcuson Dr. Peter K. Robertson Mr. Blaise E. Genes, CEC Mr. Richard G. Almes
<u>Chapter 8</u> Site Mining and Foundation Issues	Dr. James L. Withiam, D'Appolonia Mr. Robert E. Snow, D'Appolonia Mr. Christopher J. Lewis, D'Appolonia	Dr. Vincent A. Scovazzo, J.T. Boyd Mr. Frederick R. Vass, Alliance Dr. Kelvin K. Wu Mr. Richard G. Almes
<u>Chapters 9 and 10</u> Hydrology and Hydraulics Environmental Considerations	Ms. Colleen M. Campbell, D'Appolonia Mr. Robert E. Snow, D'Appolonia Dr. J. Timothy Onstott, D'Appolonia	Mr. Richard G. Almes
<u>Chapters 11 and 12</u> Construction and Disposal Operations Monitoring, Inspection and Facility Maintenance	Mr. Robert M. Shusko, D'Appolonia Mr. Robert E. Snow, D'Appolonia	Mr. Frederick R. Vass, Alliance Mr. Richard G. Almes
<u>Chapter 13</u> Instrumentation	Dr. James L. Withiam, D'Appolonia	Mr. Richard G. Almes
<u>Chapter 14</u> Emergency Action Planning	Dr. J. Timothy Onstott, D'Appolonia	Mr. Richard G. Almes

Suggestions for changes, corrections, or updates to this Manual should be directed to:

Mine Safety and Health Administration
Pittsburgh Technical Support Center
Mine Waste and Geotechnical Engineering Division
P.O. Box 18233
Pittsburgh, PA 15236
Attention: Dam Safety Officer

For any suggested changes, corrections or updates, commenters should identify specific pages, paragraphs, tables, or figures within the Manual, along with proposed replacement or new material. Sources of proposed material should be completely cited, along with permission for use in a future revised edition of this document.

This document is intended solely for noncommercial and educational purposes. The material presented in this Manual has been prepared in accordance with recognized engineering practices as cited herein. The guidance should not be used without first securing competent advice with respect to its suitability for any application. The publication of the material contained herein is not intended as any representation or warranty, either expressed or implied, on the part of the individuals, firms or agencies involved, or any other person or organization named herein, that this information is suitable for

any general or specific use or promises freedom from infringement of any patent or patents. Anyone making use of this information assumes all liability resulting from such use. Reference to commercial products or firms and use of trade names and trademarks in this document is for descriptive purposes only, does not constitute endorsement, and may not be used for advertising or promotion purposes.

Table of Contents

Preface	iii
List of Tables	xxvii
List of Figures	xxxiii
Acronyms	xli
Chapter 1	Introduction
Chapter 2	Background and Characterization of Coal Refuse
2.1 GEOLOGICAL NATURE OF COAL REFUSE	2-2
2.1.1 Origin of Coal	2-2
2.1.2 Coal-Related Rocks.....	2-3
2.2 COAL MINING AND COAL PREPARATION (CLEANING)	2-4
2.3 REFUSE TRANSPORT AND DISPOSAL PLACEMENT	2-6
2.3.1 Coarse Refuse.....	2-6
2.3.2 Fine Refuse and Combined Refuse	2-6
2.4 COAL REFUSE CHARACTERIZATION.....	2-7
2.4.1 General Geochemical Characteristics	2-7
2.4.2 General Geotechnical Characteristics	2-7
2.4.2.1 Coarse Coal Refuse.....	2-8
2.4.2.2 Fine Coal Refuse Slurry	2-8
2.4.2.3 Dewatered Fine Coal Refuse.....	2-9
2.4.2.4 Combined Coal Refuse	2-9
2.4.2.5 Fine Coal Refuse Paste	2-10
2.5 DISPOSAL PRACTICES.....	2-10
2.5.1 Disposal Practices Prior to the Buffalo Creek Failure	2-10
2.5.2 Disposal Practices Subsequent to the Buffalo Creek Failure.....	2-11

Chapter 3 Coal Refuse Disposal Facilities and Other Impounding Structures

3.1	Hazard Potential for Disposal Facilities and Other Impounding Structures.....	3-1
3.2	Coal Refuse Impoundment Facilities.....	3-3
3.2.1	Size and Hazard Considerations.....	3-4
3.2.1.1	Impoundment Definition	3-4
3.2.1.2	Impoundments in Series.....	3-5
3.2.1.3	Incised Impoundments	3-5
3.2.2	Disposal Facility Configuration.....	3-6
3.2.3	Hazard Potential Rating.....	3-9
3.3	COAL REFUSE NON-IMPOUNDING FACILITIES (REFUSE PILES)	3-10
3.3.1	Coarse Refuse Embankments.....	3-10
3.3.2	Combined Refuse Embankments.....	3-11
3.3.3	Segregated Refuse Embankments	3-11
3.3.4	Configuration and Development Staging.....	3-11
3.4	COAL REFUSE SLURRY CELL FACILITIES.....	3-12
3.4.1	Size and Hazard Classification.....	3-13
3.4.2	Disposal Facility Configuration and Development	3-16
3.5	UNDERGROUND INJECTION SITES	3-17
3.5.1	Siting	3-17
3.5.2	Injection System Design	3-18
3.5.3	Risk Assessment and Response Plan	3-19
3.5.4	Contingency Plan	3-20
3.5.5	Monitoring Plan	3-20
3.6	RECOVERY (REMINING) OF COAL REFUSE DISPOSAL FACILITIES	3-21
3.7	OTHER IMPOUNDING STRUCTURES	3-22
3.8	SMALL PONDS AND SIMILAR STRUCTURES	3-23

Chapter 4 Project Planning

4.1	UNIQUE ASPECTS OF REFUSE DISPOSAL	4-1
4.2	OPERATIONS AND SITE-RELATED FACTORS	4-2
4.3	SUSTAINABLE MINING PRACTICES.....	4-4
4.4	ECONOMIC CONSIDERATIONS.....	4-4
4.5	ENVIRONMENTAL AND REGULATORY CONSIDERATIONS	4-6
4.6	PLANNING SEQUENCE.....	4-7
4.7	DESIGN SEQUENCE	4-7

Chapter 5**Coal Refuse Disposal Facility
Design Components**

5.1	DISPOSAL CAPACITY REQUIREMENTS AND SCHEDULING.....	5-1
5.1.1	Refuse Generation Rates and Design Capacity/Life.....	5-1
5.1.2	Slurry Impoundment Staging and Scheduling.....	5-2
5.1.3	Slurry Cell Staging.....	5-3
5.1.4	Non-impounding Refuse Embankment Staging.....	5-5
5.1.5	Amendments and Co-disposal of Combustion Waste.....	5-7
5.1.5.1	Amendments for Neutralization and Stabilization of Refuse.....	5-7
5.1.5.2	Co-disposal of Combustion Waste.....	5-7
5.2	EROSION AND SEDIMENTATION CONTROL AND DESIGN STORM RUNOFF MANAGEMENT.....	5-8
5.2.1	Erosion and Sedimentation Control.....	5-8
5.2.2	Slurry Impoundment Inflow Design Storm.....	5-9
5.2.3	Slurry Cell Facilities.....	5-9
5.2.4	Refuse Embankment Design Storm.....	5-11
5.3	FACILITY CONFIGURATION AND GEOMETRY.....	5-11
5.3.1	Regulatory Criteria.....	5-11
5.3.2	Embankment Design Considerations.....	5-11
5.3.2.1	Stability under Normal Operating Conditions.....	5-11
5.3.2.2	Stability under Extreme Events.....	5-12
5.3.2.3	Settlement and Subsidence.....	5-12
5.3.2.4	Environmental Issues, Impoundment Elimination and Site Reclamation.....	5-13
5.3.3	Impoundment Design Considerations.....	5-13
5.3.3.1	Settling and Clarification.....	5-13
5.3.3.2	Seepage Control and Containment.....	5-13
5.3.3.3	Spillway and Decant Systems.....	5-13
5.3.3.4	Subsidence and Breakthrough Potential.....	5-13
5.4	FOUNDATION AND MINE SUBSIDENCE CONSIDERATIONS.....	5-13
5.4.1	Foundation Materials.....	5-13
5.4.2	Abutment and Foundation Geometry.....	5-14
5.4.3	Mine Subsidence Potential.....	5-14
5.4.4	Impoundment Breakthrough Potential into Mine Workings.....	5-15
5.4.5	Mine Entry Barriers and Bulkheads.....	5-16
5.5	INTERNAL DRAINAGE AND EMBANKMENT SEEPAGE CONTROL.....	5-16
5.6	DECANT AND EMERGENCY SPILLWAY SYSTEMS.....	5-17
5.6.1	Decant Performance Considerations.....	5-17
5.6.2	Open-Channel Spillway Performance Considerations.....	5-18
5.7	SURFACE DRAINAGE CONTROLS.....	5-18

5.7.1	Permanent Drainage Controls	5-18
5.7.2	Temporary Drainage Controls.....	5-19
5.8	INSTRUMENTATION AND PERFORMANCE MONITORING	5-19
5.8.1	Seepage	5-19
5.8.2	Piezometric Levels.....	5-19
5.8.3	Pool Levels	5-19
5.8.4	Rainfall Data	5-20
5.8.5	Deformation or Movement.....	5-20
5.9	RECLAMATION, ABANDONMENT AND POST-MINING LAND USE	5-20

Chapter 6 Geotechnical Exploration, Material Testing, Engineering Analysis and Design

6.1	GEOTECHNICAL DESIGN PROCEDURES	6-2
6.2	GENERAL CONSIDERATIONS.....	6-2
6.2.1	Unique Characteristics of Refuse Disposal Facilities	6-2
6.2.2	Site Conditions	6-4
6.2.2.1	Topography.....	6-4
6.2.2.2	Climate/Weather	6-6
6.2.2.3	Geology and Surficial Soils.....	6-6
6.2.2.4	Miscellaneous Site Considerations.....	6-7
6.2.3	Embankment Materials	6-8
6.2.3.1	Coarse Coal Refuse.....	6-8
6.2.3.2	Fine Coal Refuse	6-10
6.2.3.3	Combined Refuse	6-10
6.2.3.4	Borrow Materials.....	6-11
6.2.3.5	Coal Combustion Products from Power Plants.....	6-13
6.2.4	Scheduling	6-18
6.3	DESIGN CONSIDERATIONS	6-19
6.3.1	Impounding Embankments	6-19
6.3.1.1	Homogeneous Embankments.....	6-21
6.3.1.2	Zoned Embankments.....	6-21
6.3.1.3	Foundation Seepage Control	6-26
6.3.2	Non-impounding Embankments	6-30
6.3.3	Slurry Cell Embankments	6-34
6.3.4	Embankment Construction Staging.....	6-35
6.3.4.1	Upstream Method	6-35
6.3.4.2	Downstream Method	6-37
6.3.4.3	Centerline Method	6-38
6.3.4.4	Embankments Supplemented with Borrow Material.....	6-39
6.3.5	Special Considerations for Existing Embankments.....	6-39
6.3.6	Other Impounding Embankments.....	6-41

6.4	SITE GEOTECHNICAL/GEOLOGICAL EXPLORATION	6-43
6.4.1	Background Data Sources	6-44
6.4.1.1	Topographic Maps.....	6-44
6.4.1.2	Geologic Maps and Publications.....	6-46
6.4.1.3	Agricultural Soil Surveys	6-47
6.4.1.4	Satellite Imagery, Aerial Photographs and Other Imagery.....	6-47
6.4.1.5	Past Investigations and Area Mining Plans	6-48
6.4.1.6	Individual Site Mapping	6-49
6.4.2	Surficial Reconnaissance and Geologic Mapping.....	6-49
6.4.3	Subsurface Exploration and In-Situ Test Planning.....	6-50
6.4.3.1	Program Planning.....	6-52
6.4.3.2	Subsurface Exploration and In-situ Test Methods and Applicability	6-54
6.4.3.3	Test Pits.....	6-55
6.4.3.4	Boring Methods and the Standard Penetration Test (SPT)	6-57
6.4.3.5	Undisturbed Soil Sampling	6-59
6.4.3.6	Rock Coring.....	6-59
6.4.3.7	Cone Penetrometer Test (CPT) and Piezocone Penetrometer Test (CPTu or PCPT)	6-61
6.4.3.8	Field Vane Shear Test (FVST)	6-63
6.4.3.9	Directional (Longhole) Drilling	6-66
6.4.3.10	Field Hydraulic Conductivity Tests	6-67
6.4.3.11	Groundwater-Level Measurements	6-68
6.4.3.12	Water Flow and Quality Tests	6-69
6.4.3.13	Backfilling of Boreholes	6-69
6.4.4	Geophysical Methods	6-70
6.4.4.1	Surficial Geophysical Techniques.....	6-71
6.4.4.1.1	Seismic Refraction	6-71
6.4.4.1.2	Seismic Reflection	6-74
6.4.4.1.3	Electrical Resistivity.....	6-76
6.4.4.1.4	Spontaneous Potential (SP)	6-78
6.4.4.1.5	Electromagnetics (EM)	6-79
6.4.4.1.6	Ground Penetrating Radar (GPR)	6-80
6.4.4.1.7	Gravity.....	6-82
6.4.4.1.8	Magnetics	6-83
6.4.4.2	Borehole Geophysical Techniques	6-83
6.4.4.2.1	Crosshole and Downhole/Uphole Seismic Surveys	6-85
6.4.4.2.2	Video and Laser/Sonar Imaging	6-89
6.5	MATERIAL PROPERTY DETERMINATION THROUGH TESTING.....	6-90
6.5.1	Selection of Samples for Testing	6-91
6.5.1.1	Bulk and Disturbed Samples	6-91
6.5.1.2	Undisturbed Samples	6-95
6.5.1.3	Reconstituted Samples.....	6-96

6.5.2	Classification and Index Property Tests	6-96
6.5.2.1	Moisture Content.....	6-97
6.5.2.2	Specific Gravity	6-100
6.5.2.3	Atterberg Limits	6-101
6.5.2.4	Particle-size Distribution.....	6-102
6.5.2.5	Chemical Characterization	6-104
6.5.3	Compaction and Density Tests	6-105
6.5.3.1	Fine-grained Soils and Coal Refuse.....	6-105
6.5.3.2	Coarse-Grained Soils and Coal Refuse	6-108
6.5.4	Hydraulic Conductivity Tests	6-109
6.5.5	Geosynthetic Materials Tests	6-111
6.5.6	Consolidation Tests	6-112
6.5.7	Shear Strength and Related Tests	6-116
6.5.7.1	Vane-Shear Test	6-120
6.5.7.2	Direct-Shear Test	6-120
6.5.7.3	Unconfined-Compression Test	6-122
6.5.7.4	Triaxial-Compression Test	6-124
6.5.8	Seismic Property Characterization	6-128
6.5.8.1	Cyclic-Triaxial Test	6-128
6.5.8.2	Cyclic Loading Followed by Monotonic Loading.....	6-128
6.5.8.3	Resonant-Column Test.....	6-129
6.5.9	Rock Property Tests	6-129
6.5.9.1	Point-Load Index Test.....	6-129
6.5.9.2	Unconfined Compressive Strength Test.....	6-132
6.5.9.3	Indirect Tensile Strength Test	6-133
6.5.9.4	Rock Durability	6-133
6.5.10	Structural Material Tests.....	6-135
6.5.10.1	Concrete.....	6-135
6.5.10.2	Controlled Low-Strength Materials (CLSM).....	6-135
6.5.11	Verification of Test Results.....	6-137
6.6	GEOTECHNICAL ANALYSES	6-138
6.6.1	Analytical and Numerical Methods in Geotechnical Engineering.....	6-138
6.6.2	Seepage Analysis	6-139
6.6.2.1	Basic Assumptions, Conditions Requiring Seepage Analysis	6-139
6.6.2.2	Seepage Analysis Methods	6-142
6.6.2.2.1	Graphical (Flow Net) Approach	6-143
6.6.2.2.2	Analytical Solutions	6-144
6.6.2.2.3	Numerical Modeling Approach	6-145
6.6.2.3	Seepage Control Measures	6-146
6.6.2.3.1	Granular Drain and Filter Requirements.....	6-146
6.6.2.3.2	Geotextile-Wrapped Drains	6-149
6.6.2.3.3	Seepage Control along Conduits.....	6-156

6.6.2.3.4	Relief Wells	6-160
6.6.2.3.5	Horizontal Drains	6-161
6.6.2.3.6	Impoundment Liners	6-163
6.6.2.3.7	Foundation Seepage Cutoffs.....	6-164
6.6.2.3.8	Impoundment Water and Slurry Deposition Management	6-164
6.6.2.4	Seepage Measurements.....	6-164
6.6.3	Settlement Analysis	6-164
6.6.3.1	Conditions Requiring Deformation Analysis	6-164
6.6.3.2	Settlement and Deformation Analysis.....	6-167
6.6.3.3	Deformation Control Measures	6-170
6.6.3.4	Deformation Measurements	6-170
6.6.4	Slope Stability Analysis.....	6-171
6.6.4.1	Conditions Requiring Stability Analysis.....	6-171
6.6.4.2	Methods of Stability Analysis	6-173
6.6.4.2.1	Limit Equilibrium Stability Analysis.....	6-173
6.6.4.2.2	Stability/Deformation Analysis Using Finite Element Methods.....	6-181
6.6.4.3	Acceptable Factors of Safety	6-181
6.6.4.4	Stability Control Measures	6-184
6.6.4.5	Stability Measurements.....	6-185
6.6.5	Rock Excavations	6-185
6.6.5.1	Conditions Requiring Stability Analysis.....	6-185
6.6.5.1.1	Existing Ground Surface Slope	6-185
6.6.5.1.2	Overburden Soil Thickness, Type and Quality	6-185
6.6.5.1.3	Bedrock Surface Conditions	6-186
6.6.5.1.4	Rock Type, Quality and Configuration.....	6-187
6.6.5.1.5	Groundwater Conditions	6-189
6.6.5.1.6	Other Factors.....	6-189
6.6.5.2	Slope Stability Analysis.....	6-189
6.6.5.3	Stability Control Measures	6-191
6.6.5.4	Stability Measurements.....	6-193
6.6.6	Conduit Structural Design for Earthen Fill Loads.....	6-193
6.6.6.1	Conduit Types	6-194
6.6.6.1.1	Concrete.....	6-194
6.6.6.1.2	Thermoplastic	6-195
6.6.6.1.3	Metal	6-195
6.6.6.2	Soil-Structure Design	6-196
6.6.6.3	Conduit Installation and Design Details.....	6-201
6.6.6.3.1	Installation	6-201
6.6.6.3.2	Rigid Conduit Support.....	6-201
6.6.6.3.3	Flexible Conduit Support.....	6-202
6.6.6.3.4	Watertightness	6-204
6.6.7	Blasting Impacts.....	6-206

Chapter 7

Seismic Design: Stability and Deformation Analyses

7.1	GENERAL	7-1
7.1.1	Design Approach.....	7-1
7.1.1.1	Seismic Instability.....	7-2
7.1.1.2	Excessive Deformations	7-3
7.1.2	Seismic Design Considerations and Flow Chart.....	7-3
7.1.3	Sand-Like Versus Clay-Like Material.....	7-9
7.1.4	Susceptibility to Strength Loss	7-11
7.1.5	Simplified Steps for Seismic Stability	7-12
7.1.5.1	Step 1	7-12
7.1.5.2	Step 2	7-12
7.1.5.3	Step 3	7-12
7.1.5.4	Step 4	7-12
7.1.5.5	Step 5	7-13
7.1.5.6	Step 6	7-13
7.2	TERMINOLOGY.....	7-14
7.3	CHARACTERIZATION OF SUBSURFACE CONDITIONS AND MATERIAL PROPERTIES.....	7-18
7.4	SEISMIC STABILITY ANALYSES.....	7-21
7.4.1	General Discussion.....	7-21
7.4.1.1	Triggering Analyses	7-21
7.4.1.2	Evaluation of Post-Earthquake Strength.....	7-22
7.4.1.3	Stability Analysis Using Post-Earthquake Strengths.....	7-23
7.4.2	Triggering Analyses	7-23
7.4.2.1	Pore-Pressure-Based Method for Triggering of Strength Loss in Clay-Like Material.....	7-23
7.4.2.2	Pore-Pressure-Based Method for Triggering of Strength Loss in Sand-Like Material.....	7-23
7.4.2.2.1	Evaluation of Cyclic Stress Ratio (<i>CSR</i>).....	7-25
7.4.2.2.2	Evaluation of Cyclic Resistance Ratio (<i>CRR</i>)	7-28
7.4.2.2.3	Correction Factors for Earthquake Magnitude, High Overburden, Sloping Ground and Age of Deposit	7-31
7.4.2.3	Strain-Based and Stress-Based Methods to Evaluate Triggering of Strength Loss	7-32
7.4.2.3.1	Clay-Like Material: Strain-Based Method for Triggering.....	7-32
7.4.2.3.2	Sand-Like Material: Strain-Based Method for Triggering	7-33
7.4.2.3.3	Sand-Like Material: Stress-Based Method for Triggering	7-35
7.4.3	Evaluation of Post-Earthquake Strength.....	7-36
7.4.3.1	Correlations of SPT and CPT with S_{us} of Sand-Like Material	7-36
7.4.3.2	Laboratory Testing for Measuring Post-Earthquake Strength for Clay-Like Material and S_{us} for Sand-Like Material.....	7-41
7.4.3.2.1	Laboratory Testing Issues	7-41
7.4.3.2.2	Laboratory Testing of Soft Clay-like Material to Measure Post-Earthquake Strength.....	7-41
7.4.3.2.3	Laboratory Testing of Sand-like Material to Measure S_{us}	7-44

7.4.3.3	Field testing to Measure S_{us} of Soft Clay-Like Material	7-51
7.4.4	Analysis Steps	7-51
7.4.4.1	Step 1 - Define Embankment Geometry	7-51
7.4.4.2	Step 2 - Screen for Potential Strength Loss	7-51
7.4.4.2.1	Sand-Like Material.....	7-51
7.4.4.2.2	Clay-Like Material	7-52
7.4.4.2.3	Screening Results	7-54
7.4.4.3	Step 3 - Define Post-Earthquake Strengths for Limit Equilibrium Stability Analyses.....	7-54
7.4.4.4	Step 4 - Perform Initial Stability Analysis.....	7-56
7.4.4.5	Optional Step 5 - Perform More Detailed Evaluation of S_{us} for Sand-Like Material	7-57
7.4.4.6	Optional Step 6 - Perform Triggering Analysis.....	7-57
7.4.5	Comments on Methods for Evaluating Triggering and Strength.....	7-58
7.5	SEISMIC DEFORMATION ANALYSES	7-59
7.5.1	General Discussion.....	7-59
7.5.2	Preliminary Screening.....	7-61
7.5.3	Pseudo-Static Procedure for Screening.....	7-61
7.5.4	Newmark-Type Analysis (No Cyclic Mobility)	7-62
7.5.5	Numerical Modeling with No Cyclic Mobility.....	7-65
7.5.6	Numerical Modeling Considering Cyclic Mobility	7-65
7.5.7	Acceptable Deformations.....	7-66
7.6	EMBANKMENT MODIFICATIONS FOR IMPROVING STABILITY OR RESISTANCE TO DEFORMATIONS	7-66
7.7	SEISMIC HAZARD ASSESSMENT (SEISMICITY).....	7-66
7.7.1	Analytical Procedures.....	7-71
7.7.1.1	Deterministic Seismic Hazard Analysis (DSHA).....	7-71
7.7.1.2	Probabilistic Seismic Hazard Analysis (PSHA).....	7-73
7.7.1.3	DSHA versus PSHA	7-74
7.7.2	Seismotectonic Modeling	7-76
7.7.2.1	Regional Tectonic Framework.....	7-77
7.7.2.2	Historical Seismicity.....	7-78
7.7.2.3	Selection of Seismic Sources	7-78
7.7.2.4	Maximum Magnitude	7-79
7.7.2.5	Earthquake Recurrence	7-81
7.7.3	Design Ground Motion.....	7-81
7.7.3.1	Selection of Design Earthquakes.....	7-82
7.7.3.2	Ground Motion Attenuation.....	7-83
7.7.3.3	Selection of Peak Ground Motion Parameters.....	7-84
7.7.3.4	Selection of Acceleration Time Histories.....	7-84
7.7.3.5	Applicability of Design Ground Motion	7-86
7.7.3.6	Application of Seismic Parameters in Design Process	7-86
7.7.3.7	Simplified Design Ground Motion for Areas of Low Seismic Hazard.....	7-86
7.8	SEISMIC DESIGN OVERVIEW.....	7-88

APPENDIX 7A	DERIVATIONS OF BASIC EQUATIONS FOR STEADY-STATE LABORATORY TESTING	
APPENDIX 7B	VOID-RATIO MEASUREMENTS DURING UNDISTURBED TUBE SAMPLING AND LABORATORY TESTING	
APPENDIX 7C	PROCEDURE FOR UNDISTURBED, FIXED-PISTON SAMPLING OF COHESIONLESS SOIL	
APPENDIX 7D	COMBINING NEWMARK-TYPE DISPLACEMENTS COMPUTED USING 1D SITE-RESPONSE ANALYSIS	

Chapter 8

Site Mining and Foundation Issues

8.1	GENERAL CONSIDERATIONS.....	8-2
8.2	Available Sources of Site Information.....	8-3
8.2.1	Mine Maps.....	8-3
8.2.2	Coal Contour Maps and Outcrops.....	8-4
8.2.3	Interpretation and Accuracy of Mine Maps.....	8-5
8.3	ON-SITE RECONNAISSANCE AND EXPLORATION.....	8-6
8.3.1	Surficial Reconnaissance.....	8-6
8.3.2	Geophysical Methods.....	8-7
8.3.3	Long-Hole Directional Drilling.....	8-7
8.3.4	Conventional Drilling and Sampling.....	8-7
8.4	EVALUATION OF MINE SUBSIDENCE AND BREAKTHROUGH.....	8-9
8.4.1	Mine Subsidence Considerations.....	8-10
8.4.2	Potential Subsidence and Failure Mechanisms.....	8-14
8.4.2.1	Sinkholes.....	8-15
8.4.2.2	Pillar Failure.....	8-18
8.4.2.3	Pillar Punching (Floor Failure).....	8-19
8.4.2.4	Outcrop Barrier Failure by Shear or Punching.....	8-20
8.4.2.5	Internal Erosion.....	8-20
8.4.2.6	Bulkhead Failure.....	8-22
8.4.2.7	Trough Subsidence and Subsidence Cracks.....	8-22
8.4.2.8	Failures Related to Auger and Highwall Mining.....	8-23
8.4.2.9	Hillside Movement or Disturbance.....	8-24
8.4.2.10	Mine Blowout.....	8-24
8.4.2.11	Seismic and Blasting Events.....	8-24
8.4.3	Mine Subsidence Potential and Analysis.....	8-25
8.4.3.1	Pillar Evaluation and Analysis.....	8-25
8.4.3.2	Subsidence Evaluation and Analysis.....	8-28
8.4.3.3	Subsidence Damage Criteria.....	8-29
8.4.4	Mine Breakthrough Potential and Analysis.....	8-30
8.4.4.1	Outcrop Barriers.....	8-30
8.4.4.2	Overburden Barriers.....	8-33
8.5	SUBSIDENCE AND BREAKTHROUGH MITIGATION METHODS.....	8-34
8.5.1	Mine Subsidence and Breakthrough Mitigation.....	8-35

8.5.1.1	Use of Safety Zones.....	8-35
8.5.1.2	Mine Backfilling.....	8-35
8.5.1.3	Stowing of Mine Openings and Associated Barrier Construction.....	8-36
8.5.1.4	Bulkhead Construction.....	8-38
8.5.1.5	Construction of Compacted Earthen Barriers on the Surface.....	8-39
8.5.1.6	Conversion to Slurry Cells.....	8-39
8.5.1.7	Sealing Sources of Leakage.....	8-40
8.5.1.8	Stabilization of Fines.....	8-40
8.5.1.9	Overexcavation and Induced Subsidence.....	8-41
8.5.1.10	Monitoring Provisions.....	8-42
8.5.2	Mine Entry Bulkhead Seal Design.....	8-42
8.5.2.1	Site Preparation.....	8-42
8.5.2.2	Bulkhead Types.....	8-43
8.5.2.3	Design Loads.....	8-47
8.5.2.4	Design of Solid Concrete Block Bulkheads.....	8-47
8.5.2.5	Design of Concrete Bulkheads.....	8-48
8.5.2.5.1	Design of Reinforced-Concrete Bulkheads for Flexure.....	8-48
8.5.2.5.2	Design of Unreinforced-Concrete Plug Bulkheads for Shear.....	8-49
8.5.2.5.3	Design of Reinforced-Concrete Bulkheads for Shear.....	8-50
8.5.2.6	Monitoring of Bulkheads.....	8-51
8.6	FOUNDATION-RELATED CONSTRUCTION AND OPERATIONS MONITORING.....	8-52
8.7	MINE BACKFILLING DESIGN.....	8-53
8.8	SURFACE MINE SPOIL ISSUES.....	8-55
8.8.1	Surface Mine Spoil Characteristics.....	8-55
8.8.2	Design and Construction Considerations.....	8-56
8.9	SURFACE MINE HIGHWALL ISSUES.....	8-59

Chapter 9

Hydrology and Hydraulics

9.1	GENERAL CONSIDERATIONS.....	9-2
9.2	HYDROLOGY AND HYDRAULICS PRINCIPLES.....	9-2
9.2.1	Basic Design Principles.....	9-5
9.2.2	Definition and Discussion of Key Runoff Elements.....	9-7
9.2.2.1	Watershed Boundary and Area.....	9-7
9.2.2.2	Precipitation.....	9-7
9.2.2.2.1	Rainfall Curves.....	9-9
9.2.2.2.2	Rainfall Intensity.....	9-9
9.2.2.3	Watershed Characteristics.....	9-10
9.2.3	Key Storage and Outflow Elements.....	9-11
9.2.3.1	Impoundment Capacity.....	9-11
9.2.3.2	Decants, Principal Spillways and Auxiliary Spillways.....	9-11
9.3	GENERAL CONSIDERATIONS FOR COAL REFUSE DISPOSAL FACILITIES.....	9-15

9.3.1	Special Characteristics	9-15
9.3.2	Site Conditions	9-15
9.3.2.1	Topography.....	9-16
9.3.2.1.1	Steep Terrain.....	9-16
9.3.2.1.2	Gently Sloping Terrain.....	9-16
9.3.2.1.3	Effects of Slope on Facility Staging	9-17
9.3.2.2	Weather and Climate.....	9-19
9.3.2.3	Geology.....	9-19
9.3.3	Construction Materials	9-20
9.4	DESIGN CONSIDERATIONS FOR DISPOSAL FACILITY EMBANKMENT TYPES	9-20
9.4.1	Non-Impounding Embankments	9-20
9.4.1.1	Valley-Fill Embankments.....	9-21
9.4.1.2	Side-Hill, Ridge and Heaped Embankments.....	9-22
9.4.2	Slurry Cell Embankments	9-22
9.4.3	Slurry Impoundments.....	9-24
9.4.3.1	Cross-Valley Impoundment	9-25
9.4.3.2	Diked Impoundment.....	9-26
9.4.3.3	Incised Impoundment	9-26
9.4.4	Other Impounding Structures	9-26
9.4.4.1	Sedimentation and Treatment Ponds	9-28
9.4.4.2	Fresh Water Impoundments	9-29
9.5	DESIGN STORM CRITERIA	9-29
9.5.1	Design Storms for Impoundments.....	9-29
9.5.1.1	General Considerations.....	9-29
9.5.1.2	Recommended Design Storm Criteria	9-32
9.5.1.3	Size and Hazard-Potential Classification	9-32
9.5.1.3.1	Impoundment-Size Classification.....	9-33
9.5.1.3.2	Hazard-Potential Classification	9-33
9.5.1.4	Determination of Design Storm Precipitation	9-34
9.5.1.4.1	Prediction of the PMP and PMTS.....	9-34
9.5.1.4.2	Prediction of the 100-year and Lesser Design Storms.....	9-35
9.5.2	Special Considerations for Short-Term Conditions	9-36
9.5.3	Hydraulic Design Criteria for Drainage Conveyance Installations	9-37
9.6	DETERMINATION OF RUNOFF QUANTITIES	9-38
9.6.1	Basic Hydrology Parameters.....	9-38
9.6.1.1	Precipitation Intensity-Duration and Distribution.....	9-38
9.6.1.2	Unit Hydrographs and Time of Concentration.....	9-40
9.6.1.2.1	Snyder Unit Hydrograph	9-41
9.6.1.2.2	Clark Unit Hydrograph.....	9-42
9.6.1.2.3	SCS Dimensionless Unit Hydrograph	9-42
9.6.1.3	Precipitation-Runoff Relationship	9-46
9.6.1.3.1	General Rainfall Conditions	9-46

9.6.1.3.2	Thunderstorm Rainfall Conditions	9-49
9.6.1.4	Channel and Impoundment Storage Characteristics	9-52
9.6.2	Runoff Determination: Hydrograph Method.....	9-54
9.6.3	Peak Runoff Determination – Key Parameters Method	9-55
9.6.4	Runoff Determination – Rational Method	9-58
9.7	DESIGN OF OUTFLOW SYSTEMS	9-60
9.7.1	Basic Considerations	9-61
9.7.2	Hydraulic System Components	9-63
9.7.2.1	Inlets.....	9-63
9.7.2.2	Transport Sections	9-67
9.7.2.2.1	Open-Channel Flow.....	9-67
9.7.2.2.2	Pressure Flow	9-72
9.7.2.3	Outlets	9-81
9.7.3	Special Design Considerations	9-83
9.7.3.1	Channel Freeboard	9-83
9.7.3.2	Erosion Protection	9-83
9.7.3.2.1	Grass-Lined Channels.....	9-86
9.7.3.2.2	Riprap-Lined Channels	9-86
9.7.3.2.3	Grouted-Riprap Channels.....	9-90
9.7.3.2.4	Concrete-Lined Channels	9-92
9.7.3.2.5	Commercially Available Composite Erosion Control Products	9-93
9.7.3.3	Cavitation	9-93
9.7.3.4	Directional Changes in Open-Channel Flow	9-94
9.7.3.5	Directional Changes in Conduit Flow.....	9-94
9.7.3.6	Materials Selection.....	9-95
9.7.3.6.1	Open-Channel Lining Systems	9-95
9.7.3.6.2	Conduit Materials	9-95
9.7.4	Types of Hydraulic Systems.....	9-95
9.7.4.1	Decant Systems	9-96
9.7.4.1.1	Inlet.....	9-96
9.7.4.1.2	Transport Section	9-98
9.7.4.2	Overflow Spillway Systems	9-99
9.7.4.3	Diversion and Collection Ditches.....	9-110
9.7.4.4	Culverts	9-110
9.7.4.5	Natural Streams	9-110
9.8	RESERVOIR ROUTING	9-111
9.8.1	Basic Routing Methodology	9-111
9.8.2	Basic Routing Parameters.....	9-112
9.9	DAM BREACH ANALYSIS AND INUNDATION MAPPING	9-113
9.9.1	Background	9-113
9.9.2	Failure Scenarios	9-113
9.9.3	Analytical Methods	9-115

9.9.4	Input Data	9-116
9.9.4.1	Breach Parameters	9-116
9.9.4.2	Initial Conditions.....	9-118
9.9.4.3	Flow Channel Geometry and Roughness	9-118
9.9.5	Results of Analysis/Inundation Mapping.....	9-118
9.9.6	Sensitivity Analyses.....	9-119
9.9.7	Hazard Classification	9-119

Chapter 10

Environmental Considerations

10.1	STREAMS AND WETLANDS.....	10-1
10.2	AIR QUALITY	10-3
10.2.1	Dust Control	10-3
10.2.2	Combustion Control.....	10-4
10.2.3	Refuse Fire Extinguishment	10-5
10.2.3.1	Excavation and Removal.....	10-6
10.2.3.2	Surface Treatment	10-8
10.2.3.3	Water and Slurry Injection.....	10-9
10.3	WATER QUALITY	10-10
10.3.1	Erosion and Sedimentation	10-10
10.3.1.1	Prevention.....	10-10
10.3.1.2	Control.....	10-11
10.3.1.2.1	Sedimentation Ponds.....	10-11
10.3.1.2.2	Sediment Traps and Check Dams	10-12
10.3.1.2.3	Silt Fences.....	10-12
10.3.1.2.4	Erosion Control Blankets and Reinforcement Mats.....	10-12
10.3.1.2.5	Vegetation.....	10-12
10.3.2	Acid Generation and Control	10-12
10.3.2.1	Background.....	10-13
10.3.2.2	Grading, Compaction and Sealing	10-13
10.3.2.3	Amendments	10-13
10.3.2.4	Reclamation and Vegetative Cover	10-15
10.3.3	Water Quality Control	10-15
10.3.3.1	Diversion of Runoff	10-15
10.3.3.2	Treatment.....	10-15
10.3.4	Water Quality Impacts on Construction Materials	10-16
10.3.5	Hydrogeology.....	10-17
10.4	LINER SYSTEMS.....	10-19
10.4.1	Design Requirements.....	10-20
10.4.2	Stability	10-23
10.4.3	Performance Considerations.....	10-24
10.5	RECLAMATION	10-26

10.5.1	Design Considerations.....	10-26
10.5.2	Grading.....	10-27
10.5.3	Impoundment Elimination	10-28
10.5.4	Soil and Topsoil Cover.....	10-29
10.5.5	Vegetation.....	10-30

Chapter 11

Construction and Disposal Operations

11.1	OPERATIONAL PLANS AND CONSTRUCTION DOCUMENTS.....	11-1
11.1.1	Design Report.....	11-3
11.1.2	Construction Drawings.....	11-4
11.1.2.1	Title Sheet and Existing Conditions Plans.....	11-4
11.1.2.2	Initial Site Development Plans.....	11-5
11.1.2.3	Refuse Embankment Construction Plan Views.....	11-6
11.1.2.4	Cross Sections and Profiles.....	11-6
11.1.2.5	Detailed Plan Views and Cross Sections.....	11-8
11.1.2.6	Miscellaneous Details and Information.....	11-8
11.1.3	Technical Specifications.....	11-9
11.1.4	Operation and Maintenance Plan.....	11-11
11.1.5	Calculation Brief.....	11-13
11.2	PLANNING AND SCHEDULING.....	11-14
11.2.1	Planning of Coal Refuse Disposal Operations.....	11-14
11.2.1.1	Long-Term Planning.....	11-15
11.2.1.2	Short-Term Planning.....	11-16
11.2.2	Scheduling Methods and Application.....	11-17
11.2.2.1	Scheduling Data.....	11-17
11.2.2.2	Applicability of Scheduling Techniques.....	11-18
11.3	REFUSE TRANSPORT.....	11-19
11.3.1	Trucks and Scrapers.....	11-20
11.3.2	Conveyor Belt Systems.....	11-20
11.4	HANDLING EQUIPMENT.....	11-21
11.4.1	Loading and Hauling Equipment.....	11-21
11.4.2	Spreading Equipment.....	11-22
11.4.3	Compaction Equipment.....	11-23
11.4.4	Use of Handling Equipment for Related Activities.....	11-26
11.5	CONSTRUCTION AND PLACEMENT OF EMBANKMENT MATERIALS.....	11-26
11.5.1	Embankment Fill.....	11-26
11.5.2	Upstream Construction Implementation Procedure.....	11-33
11.5.3	Excess Coarse Refuse/Inclement Weather Disposal.....	11-35
11.5.4	Disposal of Fine Refuse Slurry.....	11-36
11.5.5	Disposal of Combined Refuse.....	11-38
11.5.6	Use of Amendments.....	11-38

11.6	RELATED ACTIVITIES.....	11-38
11.6.1	Haul and Access Road Construction and Maintenance.....	11-39
11.6.2	Liner Systems	11-39
11.6.3	Embankment Foundation Preparation.....	11-40
11.6.3.1	Clearing and Topsoil Stockpiling	11-40
11.6.3.2	Soft Soil Foundations	11-40
11.6.3.3	Competent Soil Foundations	11-40
11.6.3.4	Rock Foundations.....	11-40
11.6.3.5	Mine Spoil.....	11-41
11.6.4	Water Control.....	11-41
11.6.5	General Excavation	11-43
11.6.6	Embankment Fill Constructed from On-Site Borrow Materials	11-43
11.6.6.1	Clayey and Silty Borrow Materials	11-43
11.6.6.2	Rock and Granular Borrow Materials	11-44
11.6.6.3	Use of Mine Spoil	11-45
11.7	FACILITY APPURTENANT STRUCTURES.....	11-46
11.7.1	Material Requirements	11-46
11.7.2	Filters and Drains	11-46
11.7.2.1	Granular and Geotextile Filters.....	11-50
11.7.2.2	Granular Underdrains.....	11-51
11.7.2.3	Drainage Pipe.....	11-53
11.7.3	Culverts and Decants	11-53
11.7.4	Concrete Structures	11-54
11.7.5	Gates, Valves, Pipelines and Other Metal Work.....	11-55
11.7.6	Support Structures.....	11-55
11.7.7	Mine-Opening and Auger-Hole Seals and Drains.....	11-56
11.8	QUALITY CONTROL AND FIELD TESTING.....	11-56
11.8.1	Compaction Control.....	11-56
11.8.2	Material Testing	11-58

Chapter 12

Monitoring, Inspections and Facility Maintenance

12.1	MONITORING AND INSPECTIONS.....	12-2
12.1.1	Monitoring and Inspection Objectives.....	12-3
12.1.2	Visual Observations	12-4
12.1.2.1	Schedule and Checklist for Visual (and Other) Observations	12-7
12.1.2.2	Facility Development	12-8
12.1.2.2.1	Site Preparation.....	12-8
12.1.2.2.2	Starter Embankment and Internal Drains.....	12-8
12.1.2.2.3	Decant Pipes.....	12-12
12.1.2.2.4	Channel Construction	12-12

12.1.2.2.5	Instrumentation	12-12
12.1.2.2.6	Reclamation.....	12-12
12.1.2.3	Adjoining Area Conditions.....	12-13
12.1.2.3.1	Sloughing or Sliding.....	12-13
12.1.2.3.2	Signs of Subsidence.....	12-13
12.1.2.3.3	Evidence of Erosion.....	12-13
12.1.2.3.4	Springs or Seepage Areas.....	12-13
12.1.2.3.5	Changes in Vegetation.....	12-14
12.1.2.4	Other Development Work.....	12-14
12.1.2.4.1	Upstream Development.....	12-14
12.1.2.4.2	Downstream Development	12-14
12.1.2.4.3	Disposal of Materials Other than Coal Refuse	12-14
12.1.2.5	Refuse Disposal Operations and Maintenance.....	12-14
12.1.2.5.1	Refuse Placement and Compaction.....	12-14
12.1.2.5.2	Working Surface Maintenance	12-15
12.1.2.5.3	Embankment Crest Conditions	12-15
12.1.2.5.4	Embankment Slope Conditions	12-15
12.1.2.5.5	Liner, Foundation and Abutment Conditions	12-17
12.1.2.5.6	Internal Drains	12-17
12.1.2.5.7	Decant Pipe.....	12-17
12.1.2.5.8	Channel Conditions	12-18
12.1.2.5.9	Instrumentation	12-21
12.1.2.5.10	Reclaimed Slopes.....	12-21
12.1.3	Quality Control Sampling and Testing.....	12-21
12.2	MONITORING INSTRUMENTATION	12-22
12.3	FACILITY AND DAM SAFETY INSPECTIONS.....	12-24
12.3.1	Routine Inspections.....	12-24
12.3.1.1	Impoundments and Dams	12-24
12.3.1.2	Non-Impounding Facilities.....	12-27
12.3.2	Event-Related Inspections.....	12-27
12.3.3	Annual Dam Safety Inspections	12-27
12.4	CERTIFICATION AND CONFORMANCE REPORTING.....	12-28
12.5	MAINTENANCE	12-29
12.5.1	Routine Maintenance.....	12-29
12.5.2	Maintenance after Unusual Events	12-30
12.5.3	Long-Term Maintenance	12-30

Chapter 13

Instrumentation and Performance Monitoring

13.1	INSTRUMENTATION PROGRAM PLANNING	13-1
13.2	MEASUREMENT TECHNIQUES	13-2

13.2.1	Movements and Displacements	13-3
13.2.1.1	General Observations	13-3
13.2.1.2	Movement Measurement Techniques	13-8
13.2.1.2.1	Surveying Methods.....	13-8
13.2.1.2.2	Surface Extensometers	13-16
13.2.1.2.3	Tiltmeters.....	13-16
13.2.1.2.4	Probe Extensometers	13-18
13.2.1.2.5	Fixed Embankment Extensometers	13-19
13.2.1.2.6	Fixed Borehole Extensometers	13-20
13.2.1.2.7	Inclinometers	13-21
13.2.2	Piezometric Levels and Pore-Water Pressures.....	13-23
13.2.2.1	Piezometer Types.....	13-23
13.2.2.2	Observation Wells.....	13-24
13.2.2.3	Open-Standpipe Piezometers.....	13-25
13.2.2.4	Closed-System Piezometers	13-29
13.2.3	Surface Water Flows and Hydrologic Parameters	13-31
13.2.3.1	Measurement of Impoundment Water Level	13-31
13.2.3.2	Measurement of Seepage Flows and Other Surface Water Flows	13-32
13.2.3.2.1	Importance of Seepage Flows	13-32
13.2.3.2.2	Measurement of Seepage Flow Rates.....	13-34
13.2.3.3	Measurement of Rainfall and Snowfall	13-36
13.2.3.4	Observation of Temperature and General Weather Conditions	13-36
13.2.4	Miscellaneous Instrumentation and Monitoring	13-36
13.2.4.1	Measurement of Soil Pressure.....	13-36
13.2.4.2	Measurement of Blast Vibrations	13-39
13.2.4.3	Measurement of Temperature	13-41
13.3	INSTRUMENTATION MAINTENANCE.....	13-41
13.3.1	Importance of Maintenance and Recalibration.....	13-41
13.3.2	Recalibration and Maintenance during Service Life	13-42
13.4	AUTOMATED DATA ACQUISITION	13-42
13.5	INSTRUMENTATION COSTS.....	13-42
APPENDIX 13A MEASUREMENTS, TRANSDUCERS AND DATA-ACQUISITION SYSTEMS		

Chapter 14

Emergency Action Planning

14.1	PURPOSE	14-1
14.2	EMERGENCY ACTION PLAN PREPARATION.....	14-1
14.2.1	Background	14-1
14.2.2	Federal Guidelines for Dam Safety	14-3
14.2.3	Basic Elements of an EAP	14-3
14.2.4	Dam Inspection and Inundation Area Reconnaissance	14-4
14.2.4.1	Dam Inspection.....	14-4

14.2.4.2	Downstream Channel Reconnaissance	14-5
14.2.4.3	Physical Description	14-5
14.2.5	Inundation Map Preparation	14-5
14.2.5.1	Causes of Dam Failures	14-5
14.2.5.2	Dam Breach Analysis	14-6
14.2.5.3	Inundation Map	14-6
14.2.6	Participant Responsibilities.....	14-6
14.2.7	Implementation Triggers and Emergency Responses	14-7
14.2.8	Notification Requirements.....	14-9
14.2.9	EAP Public Copies.....	14-9
14.2.10	Exercises/Training	14-9
14.2.11	Plan Maintenance	14-10
14.2.12	EAP Appendices	14-11
14.3	PREPARATION FOR POTENTIAL EMERGENCY REMEDIAL ACTIONS.....	14-11
14.3.1	Potential Overtopping During a Storm	14-12
14.3.2	Movement or Sliding of the Embankment.....	14-12
14.3.3	Internal Erosion or Piping through the Dam, Foundation or Abutments	14-12
14.3.4	Excessive Seepage and a High Level of Saturation in the Embankment	14-13
14.3.5	Spillway Failure or Erosion that Could Cause a Dam Breach.....	14-13
14.3.6	Excessive Settlement or Subsidence of the Embankment	14-13
14.3.7	Formation of a Sinkhole on the Crest or Face of the Dam	14-14
14.3.8	Earthquake.....	14-14

List of Tables

TABLE NO.	TITLE	PAGE NO.
2.1	Classification of Coals by Rank	2-3
2.2	Coal Refuse Disposal Facility Failures and Incidents	2-13
3.1	Guidance for Flood Warning Systems at Surface Mine Pits	3-24
4.1	Coal Refuse Disposal Facility Cost Components	4-5
4.2	Planning Steps for Coal Refuse Facility Design	4-8
4.3	Typical Design Sequence	4-9
6.1	Typical Geotechnical Design Procedure for Coal Refuse Disposal Facilities	6-3
6.2	Basic Characteristics of Coal Refuse Disposal and Design Significance	6-5
6.3	Coarse Coal Refuse Characterization Summary of Average/Range of Values	6-9
6.4	Fine Coal Refuse Characterization Summary of Average/Range of Values	6-11
6.5	Combined Coal Refuse Characterization	6-12
6.6	Correlation Between USCS Classification and Properties of Compacted Soils	6-14
6.7	Correlation between USCS Classification and Relative Desirability of Soils as Compacted Fill	6-15
6.8	Approximate Correlation Between Engineering Properties and Soil Classification Groups	6-16
6.9	Class F Fly Ash	6-17
6.10	Class C Fly Ash	6-17
6.11	Fly Ash/Coal Refuse Mixture Properties	6-18
6.12	Advantages and Disadvantages of Internal Drain Types	6-23
6.13	Relative Advantages of Vertical and Sloping Embankment Cores	6-25
6.14	Clay Dispersion Potential	6-28
6.15	Guideline Subsurface Exploration Program for a New Impounding Embankment	6-54
6.16	Guideline Subsurface Exploration Program for a New Embankment without an Impoundment	6-55
6.17	Guideline Subsurface Exploration Program for An Existing Embankment	6-56

TABLE NO.	TITLE	PAGE NO.
6.18	Common Sampling Methods	6-57
6.19	Advantages and Limitations of the Standard Penetration Test	6-59
6.20	Advantages and Limitations of the Cone Penetrometer Test	6-62
6.21	Advantages and Limitations of the Field Vane Shear Test	6-65
6.22	Field Methods for Measurement of Hydraulic Conductivity	6-68
6.23	Advantages and Limitations of Surface Geophysical Testing	6-71
6.24	Surface Geophysical Methods in Relation to Typical Investigation Objectives	6-72
6.25	Physical Properties and Typical Ground Penetrating Radar Velocities for Common Earth Materials	6-82
6.26	Applicability of Common Borehole Geophysical Methods	6-87
6.27	Typical Soil and Rock Laboratory Tests for Coal Refuse Disposal Site Characterization	6-92
6.28	Typical Laboratory Soil Tests for Various Materials	6-94
6.29	Guidelines for Minimum Sample Weights	6-96
6.30	Soil Classification Chart (Laboratory Method)	6-98
6.31	In-Place Unit Weight and Specific Gravity of Coarse Coal Refuse	6-100
6.32	Unit Weight and Specific Gravity for Fine Coal Refuse	6-101
6.33	Statistical Properties for Atterberg Limits and Moisture Contents of Fine Coal Refuse at Northern Appalachian Sites	6-103
6.34	Particle-Size Distribution for Fine Coal Refuse	6-105
6.35	Test Methods for Chemical Characterization of Soil, Rock and Refuse Materials	6-106
6.36	Estimated Horizontal Hydraulic Conductivity of Fine Coal Refuse Based on Piezocone Dissipation Tests	6-111
6.37	Methods for Quality Control Testing of Geotextiles	6-113
6.38	Methods for Quality Control Testing of Geomembranes	6-114
6.39	Methods for Quality Control Testing of Geosynthetic Clay Liners	6-115
6.40	Laboratory Tests for Determining Soil Shear Strength	6-121
6.41	Summary of Fine Coal Refuse Shear Strength Parameters Based on Triaxial Test Results	6-127
6.42	Standards and Procedures for Laboratory Testing of Intact Rock	6-131
6.43	Slake Durability Classification	6-136
6.44	Quality Control Standards for Portland-Cement Concrete	6-136
6.45	Quality Control Standards for CLSM	6-136
6.46	CLSM Mix Design Guide	6-137

TABLE NO.	TITLE	PAGE NO.
6.47	Filter Criteria As A Function of Base Soil and Percent Passing No. 200 Sieve	6-148
6.48	Restrictions on Filter Particle Size to Limit Segregation	6-148
6.49	Guidelines for Evaluating Critical Nature of Severity for Drainage Applications	6-153
6.50	Geotextile Strength Property Requirements for Drainage Geotextiles	6-155
6.51	Recommended Minimum Properties for General Geomembrane Installation Survivability	6-163
6.52	Stress-Strain Relationships Used for Finite Element Deformation Analyses of Embankments and Foundations	6-169
6.53	Characteristics of Equilibrium Procedures for Slope Stability Analysis	6-174
6.54	Shear Strengths, Water Pressures, and Unit Weights for Slope-Stability Analyses	6-177
6.55	Guideline Friction Values and Efficiencies for Various Geosynthetic and Soil Combinations	6-178
6.56	Recommended Minimum Factors of Safety for Design of Coal Refuse Embankments	6-183
6.57	Common Residential Velocity Criteria and Effects	6-207
7.1	Comparison of Basic Criteria for Sand-Like, Clay-Like and Borderline Materials	7-14
7.2	References for Correlations of S_{US} with SPT and CPT Data	7-36
7.3	Correlations of S_{US}/σ_V versus SPT and CPT Data Back-Calculated from Case Histories	7-38
7.4	Upper-Bound Values of S_{US} for Corresponding Values of $N_{1,60}$	7-45
7.5	Error in Void Ratio and Corresponding Percent Error in S_{US}	7-49
7.6	MDE and Seismic Hazard Assessment Recommendations	7-72
7.7	Safe Shutdown Earthquake (SSE) Peak Horizontal Ground Accelerations for U.S. Nuclear Power Plants	7-85
8.1	Sources of Information for Evaluation of Breakthrough Potential	8-4
8.2	Sources for Mine Maps	8-5
8.3	Exploration Considerations for Assessing Impoundment Breakthrough Potential To Underground Mines	8-8
8.4	Outcrop Barrier Exploration Considerations	8-9
8.5	Summary of Guidelines for Mining Under Or Near Bodies of Water	8-11
8.6	Guidelines for Cement Grout Programs	8-63
9.1	Hydrologic and Hydraulic Design Procedures for Coal Refuse Disposal Facilities	9-3
9.2	Hydrologic and Hydraulic Design Considerations for Coal Refuse Disposal Facilities	9-6
9.3	Facility Characteristics Influencing Hydraulic System Design	9-15
9.4	Recommended Minimum Design Storm Criteria for Coal Refuse Disposal Impoundments	9-30

TABLE NO.	TITLE	PAGE NO.
9.5	NWS Precipitation Frequency Publications	9-37
9.6	Typical Design Criteria for Minor Hydraulic Structures	9-38
9.7	Methods for Determining Runoff Rate and Volume	9-39
9.8	Recommended Correction Factors for T_c for Watersheds West of the 105 th Meridian	9-43
9.9	Roughness Coefficients (Manning's n) for Sheet Flow	9-44
9.10	Runoff Curve Numbers for Watershed Complexes and AMC-II	9-50
9.11	Runoff Curve Numbers (CN) for Antecedent Moisture Conditions	9-52
9.12	Runoff Coefficient s for Use in the Rational Method	9-60
9.13	Manning's Coefficients of Channel Roughness	9-72
9.14	Head Loss Coefficients for Conduits	9-77
9.15	References for Secondary Hydraulic Design Issues	9-81
9.16	Permissible Velocity and Tractive Force for Channel Linings	9-85
9.17	Vegetal Retardance Classes	9-87
9.18	Riprap Size Designation	9-89
9.19	Recommended Grading of Grouted Rock Riprap Lining	9-91
9.20	Inundation Analysis Software	9-115
9.21	Hazard Potential Classifications	9-119
10.1	Fire Extinguishment Techniques	10-7
10.2	Summary of Suggested Criteria for Interpreting Acid-Base Accounting	10-14
10.3	Chemical Compounds Used in AMD Treatment	10-16
10.4	Design Considerations for AMD Passive Treatment Systems	10-17
10.5	Overview of the Hydrogeologic Process	10-18
10.6	Site Specific Factors to Consider in Liner System Design	10-19
10.7	Available Materials or Procedures for Liner System Components	10-21
10.8	Stability Considerations in Liner Design	10-24
10.9	Liner System Performance Factors and Considerations	10-25
10.10	Potential Final Land Uses	10-26
10.11	Design Considerations for Reclamation Soils	10-27
10.12	Summary of Reclamation Guidelines	10-30
10.13	Characteristics of Common Species Potentially Suitable for Reclamation	10-31
11.1	Refuse Disposal Operations	11-2
11.2	Transport Systems and Associated Handling Equipment at the Point of Disposal	11-22

TABLE NO.	TITLE	PAGE NO.
11.3	Compaction Capabilities of Transport and Spreading Equipment	11-24
11.4	Compaction Guide for Material Types	11-28
11.5	Suggested Compaction Equipment and Methods	11-30
11.6	Effects of Corrosion and Countermeasures	11-47
12.1	Typical Observation and Inspection Checklist	12-9
12.2	Field Quality Control Testing Summary	12-25
13.1	Instrumentation Planning and Design Steps	13-3
13.2	Performance Questions for Slurry Impoundments	13-4
13.3	Summary of General Methods for Detecting Embankment Movements and Displacements	13-6
13.4	Instrument Categories for Measuring Movements	13-9
13.5	Surveying Methods	13-12
13.6	Instruments for Measuring Ground-Water Pressure	13-24
13.7	Cement-Bentonite Grout Mix	13-26
13.8	Guidance for Accurate Weir Flow Measurement	13-39
14.1	Historical U.S. Dam Failures	14-2
14.2	Guidance for EAP Events and Situations	14-8

List of Figures

FIGURE NO.	TITLE	PAGE NO.
2.1	Coarse Coal Refuse Embankment and Sample Gradation	2-8
2.2	Fine Coal Refuse Slurry Characteristics	2-9
2.3	Combined Coal Refuse Materials	2-10
3.1	Cross-Valley Impounding Embankment	3-5
3.2	Incised Impounding Facility	3-6
3.3	Side-Hill Impounding Embankment	3-7
3.4	Diked-Pond (Impounding) Embankment	3-8
3.5	Upstream Staging Method	3-8
3.6	Downstream Staging Method	3-9
3.7	Centerline Staging Method	3-9
3.8	Valley-Fill, Non-Impounding Embankment	3-12
3.9	Cross-Valley, Non-Impounding Embankment	3-12
3.10	Side-Hill, Non-Impounding Embankment	3-13
3.11	Ridge (Non-Impounding) Embankment	3-14
3.12	Heaped (Non-Impounding) Embankment	3-15
3.13	Slurry Cell in Valley Fill, Non-Impounding Embankment	3-16
3.14	Slurry Cell, Side-Hill, Non-Impounding Embankment	3-17
3.15	Slurry Cells in Cross-Valley Fill, Impounding Embankment	3-19
5.1	Typical Slurry Impoundment Components	5-4
5.2	Typical Slurry Cell Facility (Impounding Embankment)	5-5
5.3	Typical Refuse Embankment Components	5-6
5.4	Illustration of Impoundment Design Storm Control	5-10
5.5	Underground Mining at Slurry Impoundment	5-16
6.1	Drain Configurations for Homogeneous Embankments with Impoundments	6-22

FIGURE NO.	TITLE	PAGE NO.
6.2	Zoned Embankments with Impoundments	6-24
6.3	Resistance of Core Materials to Piping and Cracking	6-27
6.4	Seepage Cutoffs for Pervious Foundations	6-29
6.5	Impoundment Internal Drain Concept	6-30
6.6	Non-Impounding Embankments	6-32
6.7	Example Spring Collection Zones and Rock Underdrain	6-33
6.8	Upstream Construction Following Initial Development	6-35
6.9	Downstream Embankment Construction Followed by Expansion Using the Downstream and Upstream Methods	6-38
6.10	Internal Drainage Systems for Existing Impounding Embankments	6-42
6.11	Flow Chart for Site Exploration, Material Property Testing, and Facility Design	6-45
6.12	Piezocene Penetrometer	6-62
6.13	Field Vane Shear Test Setup	6-64
6.14	Vane Correction Factor	6-66
6.15	Typical Seismic Refraction Data with Interpretation	6-73
6.16	Correlation of Rippability with P-Wave Velocity for Caterpillar D-9	6-74
6.17	Seismic Reflection Principle and Schematic of Reflection Data Record	6-75
6.18	Seismic Reflection Survey Profile Over Abandoned Coal Mine Workings	6-76
6.19	Commonly Used Electrode Configurations for Ground Electrical Measurements	6-77
6.20	Resistivity Profile Across Fine Coal Refuse Impoundment	6-77
6.21	Electrical Survey of Flooded Mine Workings	6-78
6.22	Illustration of Use of SP Method to Identify Area of Seepage	6-79
6.23	Delineation of Flooded Mine Workings with TDEM Method	6-81
6.24	Resistivity of Coal Refuse from EM-31 Measurements	6-81
6.25	GPR Record of Shallow Coal Mine Workings	6-83
6.26	Theoretical Response of Gravity Geophysical Method Over 20-Foot-Diameter, Air-Filled Tunnel	6-84
6.27	Magnetic Intensity Recorded at Various Heights Above Well Casing	6-86
6.28	Field Setup for Crosshole Seismic Survey	6-88
6.29	Field Setup for Downhole Seismic Survey	6-89
6.30	Image of Mine Entry From Borehole Laser Scanner	6-90
6.31	Laser Image of Mine Workings	6-91
6.32	Plasticity Chart	6-99

FIGURE NO.	TITLE	PAGE NO.
6.33	Effect of Carbon Content on Specific Gravity of Coal Refuse Material	6-102
6.34	Particle Size Distribution	6-103
6.35	Typical Moisture-Density Relationships for Dynamic Compaction	6-107
6.36	Particle-Size Distribution of Coarse Coal Refuse After Compaction	6-108
6.37	Results of Consolidation Test on Fine Coal Refuse	6-116
6.38	Effective Stress Mohr's Circle for $\bar{C}\bar{U}$ Triaxial Test	6-118
6.39	Effective Stress Paths and Failure Envelope for $\bar{C}\bar{U}$ Triaxial Test	6-119
6.40	Direct Shear Testing Arrangement	6-122
6.41	Results of Drained Direct Shear Test on Clay	6-123
6.42	Unconfined Compression Test Results	6-124
6.43	Variation of Strength of Fine Coal Refuse with Fines Content	6-127
6.44	Typical Results for Resonant Column Test on Fine Coal Refuse	6-130
6.45	Point-Load Test Apparatus	6-132
6.46	Rotating Drum Assembly and Setup of Slake Durability Equipment	6-134
6.47	Approximation for Estimated Reduction in Hydraulic Conductivity Under Turbulent Flow	6-142
6.48	Flow Net Analysis	6-144
6.49	Flow Net Analysis for Anisotropic Conditions	6-145
6.50	Filter Diaphragm Design for Conduit	6-158
6.51	Example Design Configuration for Filter Diaphragm and Decant Pipe	6-159
6.52	Typical Relief Well Installation	6-161
6.53	Example Horizontal Drain Installation	6-162
6.54	Cracking Patterns Observed for Dams in Narrow Valleys	6-167
6.55	Histogram of Factor of Safety Distribution	6-180
6.56	Horizontal and Vertical Extent of Cuts for Base Width of 10 Feet	6-186
6.57	Schematic Geological Profile of A Bedrock Slope	6-187
6.58	Unfavorable Orientation of Bedding Planes	6-188
6.59	Favorable Orientation of Bedding Planes	6-190
6.60	Stepped Slope Example for Cuts in Weathered Rock	6-191
6.61	Examples of Rock-Cut Control	6-192
6.62	Deformations Associated With Conduits In Embankments	6-198
6.63	Reinforced Concrete Cylinder Pipe (RCCP) Details	6-204
6.64	Prestressed Concrete Cylinder Pipe (PCCP) Details (Lined Cylinder)	6-205

FIGURE NO.	TITLE	PAGE NO.
6.65	Comparison of Predicted and Observed Conduit Settlements	6-206
6.66	Acceptable Limits of Vibration for Houses	6-208
7.1a	Seismic Stability Screening	7-6
7.1b	Triggering and Seismic-Stability Analysis	7-7
7.1c	Deformation Screening and Analysis	7-8
7.2	Typical Undrained Stress-Strain Curve	7-11
7.3	Comparison of Peak Base and Crest Transverse Accelerations Measured at Earth Dams	7-27
7.4	Variation of Maximum Acceleration Ratio with Depth of Sliding Mass	7-28
7.5	SPT Clean-Sand-Based Curve for Magnitude 7.5 Earthquakes with Data from Liquefaction Case Histories	7-30
7.6	Calculation of CRR from CPT Data Along with Empirical Liquefaction Data from Compiled Case Histories	7-31
7.7	S_{us} versus $N_{1,60(CS)}$	7-37
7.8	S_{us} versus $N_{1,60}$	7-38
7.9	S_{us}/σ'_v versus q_{t1}	7-39
7.10	Steady-State Line	7-46
7.11	Method for Correcting Laboratory S_{us} to In-Situ S_{us}	7-48
7.12	Interpretation of Laboratory S_{us} Testing	7-49
7.13	Consolidation Curve and Steady-State Line	7-50
7.14	Use of CPT Data to Screen Clay-Like Material	7-53
7.15	Cyclic Stress-Strain Curve Demonstrating Ratcheting Mechanism	7-59
7.16	Double Integration to Obtain Displacement	7-64
7.17	Location of U.S. Coal Resources	7-67
7.18	Seismic Hazard Map of the U.S. with Overlay of Main Bituminous Coal Fields	7-68
7.19	Illustration of Moderate- to High-Hazard Region	7-69
7.20	Quaternary Faults and Significant Seismic Sources with Overlay of Main Bituminous Coal Fields	7-70
7.21	Return Period for $M > 5.5$ Event at a Distance Less than 50 km	7-80
7.22	Location of Nuclear Power Plants with Respect to U.S. Coal Fields	7-83
7.23	Seismic Hazard Assessment Flow Diagram	7-87
7.24	Example 1: Time History for Low-Seismic-Hazard Area	7-89
7.25	Example 2: Time History for Low-Seismic-Hazard Area	7-90
7.26	Example 3: Time History for Low-Seismic-Hazard Area	7-91

FIGURE NO.	TITLE	PAGE NO.
8.1	Strata Disturbance and Subsidence Caused By Mining	8-12
8.2	Influence of Extraction Width on Subsidence	8-12
8.3	Displacement and Strain for Various Extraction Widths	8-13
8.4	Development of Subsidence Through and Strains with Face Advance	8-14
8.5	Ground Movements Caused By Subsidence	8-15
8.6	Safety Zone Guidelines for Mining in the Vicinity of Dams and Impoundments	8-17
8.7	Hillside Disturbance at Coal Outcrop	8-21
8.8	Comparison of Pillar Strength Formulas with Respect to Width-to-Height Ratio	8-26
8.9	Outcrop Barrier Breakthrough Analysis for Shear Failure	8-32
8.10	Illustration of Overburden Barrier	8-34
8.11	Stowed Mine Openings and Barrier Construction	8-37
8.12	Barrier Against Outcrop with Low-Permeability Fill and Drain	8-38
8.13	Basic Bulkhead Design Concepts	8-44
8.14	Drift Opening Bulkhead Design Concepts	8-45
8.15	Bulkhead Configuration Showing Concrete-Block Retaining Walls and Concrete Center	8-46
8.16	Classification and Interpretation of Spoil Durability	8-58
8.17	Excavation Slopes for Preparation of Dam Abutments in Rock	8-60
8.18	Slope Modification to Reduce Differential Settlement and Potential for Cracking	8-61
8.19	Slope Modification and Seam Treatment for Sedimentary Rock Strata	8-62
9.1	Runoff and Impoundment Inflow Sources	9-8
9.2	Watershed Boundary Delineated on USGS Topographic Map	9-9
9.3	Typical Impoundment Inflow and Outflow Hydrographs	9-10
9.4	Typical Impoundment Area and Storage Volume Curves	9-12
9.5	Typical Decant Systems	9-13
9.6	Typical Decant and Spillway Systems	9-14
9.7	Channel Construction in Moderately and Steeply Sloping Terrain	9-17
9.8	Channel Construction in Gently Sloping Terrain	9-18
9.9	Drainage Control for Valley-Fill, Non-Impounding Embankment	9-21
9.10	Drainage Control for Side-Hill and Heaped Embankments	9-23
9.11	Drainage Control for Slurry-Cell Facility	9-25
9.12	Drainage Control for Cross-Valley Impoundment	9-27
9.13	Drainage Control for Diked Impoundment	9-28

FIGURE NO.	TITLE	PAGE NO.
9.14	U.S. Regions Covered by Generalized PMP Studies	9-35
9.15	Dimensionless Design Storm Distribution	9-40
9.16	Average Velocities for Estimating Travel Time for Shallow, Concentrated Flow	9-45
9.17	Direct Runoff for Rainfall Less than or Equal to 8 Inches	9-47
9.18	Direct Runoff for Rainfall Greater than or Equal to 8 Inches	9-48
9.19	Estimated Total Runoff Volume for CN = 70	9-56
9.20	Estimated Total Runoff Volume for CN = 80	9-57
9.21	Estimated Peak Runoff Rate for 6-Hour Design Storm and CN = 70	9-58
9.22	Estimated Peak Runoff Rate for 6-Hour Design Storm and CN = 80	9-59
9.23	Example of Rational Method of Inflow Calculation	9-62
9.24	Typical Head-Discharge Curves for Hydraulic Systems	9-64
9.25	Spillway Approach Channels	9-65
9.26	Drop-Inlet Decant Systems	9-66
9.27	Open-Channel Cross Sections	9-68
9.28	Channel Flow Conditions	9-70
9.29	Critical Depth for Trapezoidal and Circular Sections	9-71
9.30	Closed-Conduit Hydraulic Systems	9-73
9.31	Typical Flow Conditions – Culvert Conduits on Mild Slopes	9-74
9.32	Typical Flow Conditions – Culvert Conduits on Steep Slopes	9-75
9.33	Culvert Inlet Configurations	9-78
9.34	Flow and Discharge Characteristics of Decant-Inlet, Closed-Conduit System	9-80
9.35	Examples of Channel and Conduit Outlets	9-82
9.36	Manning's n Versus VR for Various Retardance Classes	9-88
9.37	Grouted Riprap Lining Thickness as a Function of Flow Velocity	9-91
9.38	Examples of Decants	9-100
9.39	Example Decant System at Diked Impoundment	9-101
9.40	Example Decant System at Cross-Valley Impoundment	9-102
9.41	Example Spillway System – A	9-104
9.42	Example Spillway System – B	9-105
9.43	Example Spillway System – C	9-106
9.44	Spillway Inlet Control	9-107
9.45	Spillway Outlet Control	9-108

FIGURE NO.	TITLE	PAGE NO.
9.46	Sectional View Through Impounding Facility	9-112
9.47	Breach Parameters	9-117
10.1	Liner Systems Used at Coal Refuse Disposal Facilities	10-23
11.1	Compaction by Hauling Units Using Successive Offset Passes	11-25
11.2	Procedures for Controlled Placement of Refuse	11-27
11.3	Benching of Embankment Fill Into Natural Slope	11-33
11.4	Slurry Disposal	11-37
11.5	Stockpiling and Handling of Granular Materials	11-52
12.1	Failure Modes, Warning Signs and Surveillance Measures	12-5
12.2	Example Data Collection Form	12-6
13.1	Location of Monuments Using Triangulation	13-14
13.2	Example of Benchmark in Rock	13-15
13.3	Typical Monument Installations	13-17
13.4	Probe Extensometer	13-19
13.5	Settlement Platform	13-20
13.6	Fixed Borehole Extensometer	13-21
13.7	Inclinometer Operation	13-22
13.8	Approximate Response Time for Various Types of Piezometers	13-25
13.9	Open-Standpipe Piezometer/Observation Well	13-27
13.10	Normally-Closed Pneumatic Piezometer	13-30
13.11	Vibrating-Wire Piezometer	13-31
13.12	Bonded Electrical-Resistance Piezometer	13-33
13.13	Measurement of Flow from Pipes	13-37
13.14	Typical V-Notch Weir	13-38
13.15	Flow Depth-Discharge Relationship for 90-Degree, V-Notch Weir	13-40
13.16	Automated Data Acquisition System at Coal Refuse Disposal Facility	13-43
14.1	Inundation Map for Coal Refuse Impoundment	14-7

Acronyms

ACRONYM	REPRESENTS
AASHTO	American Association of State Highway and Transportation Officials
ABS	Acrylonitrile-Butadiene-Styrene
ACI	American Concrete Institute
AC	alternating current
ALD	anoxic limestone drain
AMC	antecedent moisture condition
AMD	acid mine drainage
AMRL	AASHTO Materials Reference Laboratory
AOS	apparent opening size
ArcGIS	GIS software developed by Environmental Systems Research Institute (ESRI)
ARMPS	Analysis of Retreat Mining Pillar Stability (software)
ARMPS-HWM	ARMPS program for highwall mine pillars (software)
ASCE	American Society of Civil Engineers
ASTM	American Society for Testing and Materials
AWWA	American Water Works Association
BOD	biochemical oxygen demand
BREACH	breach parameter computation software
CADD	computer-aided design and drafting
CANDE	Culvert Analysis and Design (software)
CD	consolidated drained
CGS	Canadian Geotechnical Society
CIDC	consolidated isotropic drained compression
CISPM	Comprehensive and Integrated Subsidence Prediction Model (software)
CIUC	consolidated isotropic undrained compression
CLSM	controlled low-strength material
CMP	corrugated metal pipe
CMRR	Coal Mine Roof Rating (software)

ACRONYM	REPRESENTS
CN	curve number
CO	carbon monoxide
COSMOS	Consortium of Organizations for Strong-Motion Observation Systems
COV	coefficient of variability
CPE	chlorinated polyethylene
CPM	Critical Path Method (software)
CPP	corrugated plastic pipe
CPT	cone penetrometer test
CPTu	piezocone penetrometer test
CRR	cyclic resistance ratio
CFR	Code of Federal Regulations
CSI	Construction Specifications Institute
CSPE	chlorosulfonated polyethylene
CSR	cyclic stress ratio
CU	consolidated undrained
\overline{CU}	consolidated undrained with pore pressure measurements
CWA	Clean Water Act
DAMBRK	Dam Break (software)
DC	direct current
DCDT	direct current differential transformer
DEM	digital elevation model
DEP	Department of Environmental Protection (state environmental agencies)
DI	degradation index
DMLR	Virginia Department of Mines, Minerals, and Energy, Division of Mined Land Reclamation
DOD	Department of Defense
DOQ	digital orthophoto quadrangle
DOQQ	digital orthophoto quarter quadrangle
DRG	digital raster grid
DSHA	deterministic seismic hazard analysis
DWOPER	Dynamic Wave Routing Model (software)
EAP	Emergency Action Plan
EDM	electronic distance measuring

ACRONYM	REPRESENTS
EEGS	Environmental and Engineering Geophysical Society
EERT	Eastern Energy Resources Team
EM	electromagnetic method
EMA	Emergency Management Agency
EMC	Emergency Management Coordinator
EMS	Emergency Medical Service
EPA	U.S. Environmental Protection Agency
EPRI	Electric Power Research Institute
EROS	Earth Resources Observation and Science
ESRI	Environmental Systems Research Institute
FBC	fluidized bed combustion
FE	finite element
FEMA	Federal Emergency Management Agency
FERC	Federal Energy Regulatory Commission
FGD	flue gas desulfurization
FHWA	Federal Highway Administration
FLAC	Fast Lagrangian Analysis of Continua (software)
FLDWAV	Flood Wave (software)
FLUSH	seismic soil-structure interaction software
FR	friction ratio
FS	factor of safety
FVST	field vane shear test
GAI-LAP	Geosynthetic Accreditation Institute - Laboratory Accreditation Program
GCL	geosynthetic clay liner
GEI	Geotechnical Engineers, Inc.
GIS	geographic information system
GPR	ground penetrating radar
GPS	global positioning system
GRM	generalized reciprocal method
HDPE	high-density polyethylene
HEC	USACE Hydrologic Engineering Center
HEC-1	open channel flow analysis software
HEC-GeoHMS	GIS -based version of HEC-HMS software

ACRONYM	REPRESENTS
HEC-HMS	Hydraulic Engineering Center Hydrologic Modeling System (software)
HEC-RAS	Hydraulic Engineering Center River Analysis System (software)
HMR	Hydrometeorological Report
HSG	hydrologic soil group
ICODS	Interagency Committee on Dam Safety
IDF	inflow design flood
LAMODEL	software for computing stresses and displacements in mines
LI	liquidity index
LIDAR	light detection and ranging
LL	liquid limit
LLNL	Lawrence Livermore National Laboratory
LVDT	linear variable differential transformer
MAE	Mid-America Earthquake
MARV	minimum average roll value
MCE	maximum credible earthquake
MDE	maximum design earthquake
MIBC	methylisobutyl carbinol
MMI	Modified Mercalli Intensity
MPBX	multiple-point borehole extensometer
MSF	magnitude scaling factor
MSHA	Mine Safety and Health Administration
NAS	National Academy of Sciences
NASA	National Aeronautics and Space Administration
NCB	National Coal Board (Britain)
NEH	National Engineering Handbook
NEHRP	National Earthquake Hazard Reduction Program
NIOSH	National Institute for Occupational Safety and Health
NMO	normal moveout
NMSZ	New Madrid Seismic Zone
NOAA	National Oceanic and Atmospheric Administration
NR	not reported
NRC	National Research Council
NRCS	Natural Resources Conservation Service
NSF	National Science Foundation

ACRONYM	REPRESENTS
NSSGA	National Stone, Sand and Gravel Association
NWS	National Weather Service
OBE	operating basis earthquake
OLC	open limestone channel
OSHA	Occupational Safety and Health Administration
OSM	Office of Surface Mining
PCCP	prestressed concrete cylinder pipe
PCPT	piezocone penetrometer test
PE	polyethylene
PERT	scheduling software
PGA	peak ground acceleration
PI	plastic index
PL	plastic limit
PMF	Probable Maximum Flood
PMP	Probable Maximum Precipitation
PMTS	Probable Maximum Thunderstorm
POA	percent open area
PSHA	probabilistic seismic hazard analysis
PV	prefabricated vertical
PVC	polyvinyl chloride
Q	equivalent to UU
QA	quality assurance
QC	quality control
QUAD4	software for finite element seismic analysis of earth structures
R	equivalent to \overline{CU}
RCCP	reinforced concrete cylinder pipe
RCP	reinforced concrete pipe
RMR	rock mass rating
RQD	rock quality designation
RVSP	reverse vertical seismic profile
S	equivalent to CD
SAGEEP	Symposium on the Application of Geophysics to Engineering and Environmental Problems

ACRONYM	REPRESENTS
SAPS	successive alkalinity producing system
SCPTu	seismic piezocone penetrometer test
SCS	Soil Conservation Service (now NRCS)
SDI	slake durability index
SDPS	Surface Deformation Prediction System (software)
SEE	safety evaluation earthquake
SF	safety factor (for channel linings)
SHAKE	software for seismic analysis of subsurface layers
SHANSEP	stress history and normalized soil engineering parameters
SL	shrinkage limit
SMCRA	Surface Mining and Reclamation Act
SMPDBK	Simplified Dam Break (software)
SP	spontaneous or self potential
SPBX	single-point borehole extensometer
SPECTEXT	specification software
SPT	standard penetration test
SSE	safe shutdown earthquake
SSHAC	Senior Seismic Hazard Analysis Committee
TDEM	time-domain electromagnetic method
TDR	time-domain reflectometry
TR	technical release
USACE	U.S. Army Corps of Engineers
USBM	U.S. Bureau of Mines
USBR	U.S. Bureau of Reclamation
USCS	Unified Soil Classification System
USDA	U.S. Department of Agriculture
USDOE	U.S. Department of Energy
USEPA	U.S. Environmental Protection Agency
USGS	U.S. Geological Survey
USNRC	U.S. Nuclear Regulatory Commission
UU	unconsolidated undrained
VLDPE	very low density polyethylene
VLF	very low frequency

ACRONYM	REPRESENTS
VST	vane shear test
VSP	vertical seismic profile
WMS	Watershed Modeling System (software)
WP	wetted perimeter
WVDOT	West Virginia Department of Transportation

Chapter 1

INTRODUCTION

This Engineering and Design Manual for Coal Refuse Disposal Facilities (Manual), originally published by the Mining Enforcement and Safety Administration (MESA, 1975), has been updated for the Mine Safety and Health Administration (MSHA) of the United States Department of Labor to present current guidelines and procedures for design, construction and operation of coal refuse disposal facilities. Guidance related to dam safety issues for other impounding structures at coal mine sites, including fresh water impoundments and sedimentation and treatment ponds, is also provided in individual sections or through discussion of the associated design features. Emphasis has been placed on facility planning and materials handling and placement techniques. The input provided by MSHA, other regulatory agencies, the coal mining industry, consulting engineers and the general public has been beneficial to the preparation of this document. The guidance presented in this Manual is advisory and not intended to discourage new and innovative methods that may be applicable in specific situations.

The focus of this Manual is on design, construction and operational practices for achieving stable embankment and impoundment conditions based upon performance criteria, established regulations, and accepted engineering standards. Typical performance criteria are associated with long-term stability, flood and seismic conditions, and abandonment. Where the application to disposal practices requires interpretation that may not have been envisioned by the developers of design criteria, or where such criteria may not be available (as with some elements of seismic stability analyses), guidance is provided along with commentary describing the basis for development of the guidance. Criteria for environmental control of impacts from coal refuse disposal facilities vary from state to state. The Manual discusses features currently incorporated into disposal facilities for environmental control and provides guidance for their design and construction, as related to dam and embankment safety concerns of MSHA. Guidance for evaluating potential environmental impacts or for establishing environmental design criteria is left to other references and regulatory agencies. For example, the Manual provides information on the design and construction of liner systems for disposal facilities, but guidance relative to establishing the need for or the required hydraulic conductivity of a liner is available in other references.

Before the Buffalo Creek coal refuse facility failure in February 1972, coal refuse disposal was often subject to only cursory engineering, planning and design. Through the attention of the industry, ensuing regulatory programs, and guidance provided in the original 1975 Manual, improvements were made in the design and construction of disposal facilities. Since 1975, mining and coal processing

have undergone changes that affect the design of disposal facilities; advances in engineering practice have led to modification of design criteria; and other events such as the breakthrough of impoundment basins into abandoned underground mine workings have disclosed potential considerations that must be addressed. Thus, the original Manual has been updated to reflect these changes. While the structure and sequence of the previous Manual have been maintained, additional chapters have been added to address design components such as seismic stability, site mining and foundation issues, instrumentation, and emergency action planning.

This Manual is intended as a reference document for use by coal industry personnel and engineering staff, design consultants, and dam safety regulators involved with the planning, design, construction and regulation of refuse disposal facilities and other mine-related impoundments. It may be particularly valuable to industry personnel who perform design coordination, as a guidance document for exploration, testing, engineering analysis, design and construction document preparation, and construction monitoring and inspection. For design engineers, the Manual provides background information on coal refuse, along with methods and procedures for detailed design of coal refuse disposal facilities. Construction personnel will find descriptions of critical engineering issues that should be addressed during initial development and throughout the operational life of disposal facilities.

Chapter 2 presents an introduction to coal refuse including its origin, characteristics of the various materials making up coal refuse, and disposal practices. Current challenges in the disposal of coal refuse are also discussed.

Chapter 3 describes various types of coal refuse disposal facilities (both impounding and non-impounding) and other site impoundments and the operations and hazard potential associated with each. The classification and terminology used for embankments and impoundments are presented, consistent with conventions adopted in the 1975 Manual and MSHA publications. Additionally, underground injection of coal refuse and recovery (remining) of coal from refuse disposal facilities are also discussed.

Chapter 4 presents updated planning and technical considerations associated with disposal site selection and facility design and emphasizes the importance of close coordination between the designer and the coal operator's production staff. Past experiences with improving and expanding existing facilities and the planning of new facilities demonstrate the importance of integrating planning, design, construction and operations. The continually changing structure of refuse disposal facilities and the need to eventually reach an acceptable abandonment condition are important factors in the planning process.

Chapter 5 presents a new discussion of the design components of coal refuse disposal facilities, with emphasis on the objective of meeting the generation rates of coal preparation plants. The chapter provides the design coordinator and the engineer with an overview of the objectives of disposal facility design. The interrelationship between accommodating coal refuse generation rates, storm water and environmental control requirements, stable embankment development, and post-mining land use objectives are discussed.

Chapter 6 presents updated and new procedures for geotechnical exploration, engineering analysis, and design of coal refuse disposal facilities. Initially, the discussion addresses the unique characteristics of refuse disposal that affect facility design, as compared to the design of more commonly encountered geotechnical structures. Design concepts for embankment zoning, internal drainage control, and foundations are discussed with reference to related site exploration, testing, and geotechnical engineering analyses. The site exploration section provides new and updated guidance on cone penetration testing and geophysical methods applied to siting and design of impounding and non-impounding refuse embankments. The laboratory testing section presents descriptions and

references to standards for commonly used tests for refuse disposal facility design, along with summaries of coal refuse material properties. Geotechnical analysis topics discussed include seepage, settlement, stability, rock excavation, and conduit design. Chapter 6 is intended to provide an overview of geotechnical engineering requirements for disposal facilities for design coordinators who are familiar with coal mining operations, but may not routinely practice civil engineering as related to embankments and dams. It should also be a useful source to the practicing engineer for guidance on approaches, methods, and design elements of geotechnical engineering applied to coal refuse disposal facilities.

Chapter 7 presents new guidance for analysis of seismic stability and deformations applicable to dams and coal refuse embankments. Many slurry impoundments are constructed using the upstream construction method. Such sites are susceptible to instability during an earthquake because a portion of the dam is founded on relatively loose and saturated fine material. Major advances in the analysis of seismic stability of embankments and impoundments have occurred since the original 1975 Manual was published. Chapter 7 presents recommended design methods and flow charts to assist in seismic stability analyses. Also discussed is the importance of variation in material gradation (clay-like versus sand-like) that affects the selected approach and methods employed. Seismic hazard assessment is discussed, and guidance is provided for determining ground motion parameters considering the potential source zones and conditions found in coal regions. Deformational analysis is discussed along with criteria for tolerable deformations. Chapter 7 provides a condensed discussion of a complex subject that should allow design coordinators to gain an appreciation for the engineering required for addressing seismic stability. It will also help practicing engineers with this portion of the design by providing simplifying approaches in low-seismic-hazard regions. In regions of greater seismic hazard and for significant- and high-hazard-potential structures, more complex approaches for use by geotechnical engineers with experience in earthquake engineering are presented.

Chapter 8 has been added to the Manual to address site mining conditions, embankment foundation conditions, and impoundment stability at coal refuse facilities and the potential for subsidence and breakthrough into underground mine workings. Mitigation measures are also discussed. Additionally, unique foundation issues that may be encountered at mine sites are addressed, including evaluation of the effect of mine spoil materials and surface mine benches and highwalls on embankment and foundation design.

Chapter 9 summarizes hydrologic and hydraulic engineering methods applicable to the design of coal refuse disposal facilities. The Manual has been updated to reflect current design storm criteria. Examples of spillways, decants and channels with methods for performing design analyses and routing storms through disposal facilities are presented.

Chapter 10 addresses environmental considerations for coal refuse disposal facility design, including streams and wetlands, air quality, water quality, and reclamation. Updated guidance is provided as to methods for mitigating water quality concerns, including amendments and liner design. References are provided for evaluation of water quality impacts and treatment methods. Reclamation issues are also discussed. Design coordinators and engineers will find these sections useful when dealing with environmental issues and mitigation methods, but they will also need to be familiar with applicable state regulations and guidance.

Chapter 11 addresses disposal facility construction and operation, and **Chapter 12** discusses construction monitoring, inspection and maintenance. These chapters reflect updates in construction and disposal practices since the 1975 Manual was prepared and discuss some of the issues associated with large production mines such as material handling, placement, and compaction requirements. Guidance has been added relative to the content of construction documents and quality control programs.

[Chapter 13](#) provides a discussion of instrumentation for monitoring the performance of coal refuse disposal embankments and impoundments.

[Chapter 14](#) provides a discussion of emergency action planning. It is recommended practice in dam safety that emergency action plans (EAPs) be developed and maintained for all dams that will have a significant downstream impact in the event of their failure.

Chapter 2

BACKGROUND AND CHARACTERIZATION OF COAL REFUSE

Safe, economical and environmentally acceptable disposal of coal refuse has been made possible through the application of technology from the disciplines of geology, soil and rock mechanics, hydrology, hydraulics, geochemistry, soil science, agronomy and environmental sciences. These engineering and scientific disciplines have traditionally supported the design and construction of earthfill and rockfill embankments and dams, as well as a wide variety of waste disposal structures used in other industries. Among the various types of coal refuse disposal facilities, impoundments are one of the most critical types of structures, and they entail many of the same features and safety concerns as typical water-impounding dams. However, there are distinct differences between coal refuse disposal impoundments and conventional dams that must be considered in the transfer of dam engineering technology to coal refuse disposal, as discussed in the following:

- The primary purpose of a coal refuse disposal facility is to dispose of unusable materials from mining, not to construct an embankment to satisfy a secondary function. However, at some sites coal refuse impoundments do serve secondary purposes such as providing water storage capacity for coal processing and flood attenuation.
- Coal refuse is composed of rock fragments such as friable shale materials, and it typically includes varying amounts of coal that can have an effect on material behavior. For example, the low specific gravity of coal results in the refuse having lower specific gravities and densities than the materials encountered in typical earth embankments.
- Metals and sulfur present in some coal refuse materials may result in environmentally undesirable leachate water with serious corrosive characteristics that require special measures such as liner and collection systems or even amendments to neutralize acid production of the refuse.
- The potential for variations in coal refuse production as a result of mining or processing, plus the long-term phased method of refuse placement, should be accounted for in the disposal facility design at inception. The potential for changes in generation rates and engineering properties of the coal refuse during the life of the facility should also be recognized and provisions to accommodate these changes should be included in the design.

- The configuration of a disposal facility changes continually throughout its operational period, resulting in complications relating to control, but providing increased flexibility for planning, design and construction.
- Coal refuse disposal occurs year round, through prolonged inclement weather periods, such that the design and maintenance of the facility has to accommodate construction under adverse weather conditions.
- The construction of a disposal facility over an operational period of many years or even decades introduces the potential for discontinuity in construction oversight, quality control, monitoring, and recognition of performance factors that can affect operation and safety. The design plans should include specifications for oversight, monitoring, and quality control sufficient so that facility construction and operation meets the design intent.
- A primary planning and construction goal for a disposal facility is achievement of a safe and environmentally acceptable condition during use and upon closure and abandonment. Elimination of the impounding capability of a coal refuse disposal facility is an important design issue associated with abandonment unless maintenance of the facility is part of the planned post-mining operation of the site.

2.1 GEOLOGICAL NATURE OF COAL REFUSE

Coal refuse is composed of rock fragments unavoidably removed from the earth during the coal mining process and small amounts of coal not separated during processing. The primary source of these rocks and minerals is normally the formations immediately above and below the coal seam and the sediments within the seam. Surface mine overburden and rock removed to provide shafts, haulage-ways and other working space for the mining operation may constitute an important percentage of the total refuse material.

The proportion of rock, coal and associated minerals in any disposal facility will depend upon: (1) the geologic formation of the coal stratum, (2) the geochemical properties of the coal and adjacent materials, (3) the geometry of the coal seam, (4) the method used for mining, and (5) the process used to separate the coal from the refuse. A preparation plant may process coal from multiple seams and mining operations, resulting in some variability of the refuse product. Also, a disposal facility may receive refuse from multiple preparation plants.

2.1.1 Origin of Coal

Coal is a sedimentary rock resulting from past accumulation of plant materials in swampy conditions and subsequent metamorphism by pressure and heat to form a hard, rock-like organic material. The diversity of the original plant materials and the degree of metamorphism (coalification) that has affected these materials cause coal to be a non-uniform, combustible substance varying in both physical and chemical composition.

The predominant elements in coal are carbon, hydrogen and oxygen. Coals are rich in carbon and are classified based primarily as to the content of volatile matter. [Table 2.1](#) presents the American Society for Testing and Materials (ASTM) system for classification of coals by rank. For the anthracite and low- and medium-volatile bituminous coals, the carbon content exceeds about 70 percent. When the volatile matter exceeds about 30 percent, it becomes difficult to classify coals on the basis of volatile matter alone, and caloric value is used to distinguish high-volatile-bituminous, subbituminous, and lignite coals.

Impurities present in coal include nitrogen, sulfur, iron and various other inorganic materials (ash). These impurities can be divided into the following classes: (1) impurities that are chemically or struc-

turally a part of the coal and (2) impurities that can be mechanically removed from the coal. The amount and type of impurities that cannot be economically separated from a particular coal vary greatly and affect value. The impurities that are separable affect the refuse characteristics from a geochemical and physical standpoint. These characteristics contribute to the engineering properties of coal refuse and are thus critical to the engineering and design of disposal facilities.

TABLE 2.1 CLASSIFICATION OF COALS BY RANK

Group	Fixed Carbon Limits ⁽¹⁾ (%)	Volatile Matter Limits ⁽¹⁾ (%)	Calorific Value Limits ⁽²⁾ (BTU/lb)
Anthracite			
Meta-anthracite	≥ 98	< 2	–
Anthracite	92 to 98	2 to 8	–
Semianthracite	86 to 92	8 to 14	–
Bituminous			
Low-volatility bituminous coal	78 to 86	14 to 22	–
Medium-volatility bituminous coal	69 to 78	22 to 31	–
High-volatility-A bituminous coal	< 69	≥ 31	≥ 14,000
High-volatility-B bituminous coal	–	–	13,000 to 14,000
High-volatility-C bituminous coal	–	–	10,500 to 13,000
Subbituminous			
Subbituminous-A coal	–	–	10,500 to 11,500
Subbituminous-B coal	–	–	9,500 to 10,500
Subbituminous-C coal	–	–	8,300 to 9,500
Lignite			
Lignite A	–	–	6,300 to 8,300
Lignite B	–	–	< 6,300

Note: 1. Dry mineral-matter-free basis.
2. Moist mineral-matter-free basis.

(ADAPTED FROM ASTM, 2008a)

Sulfur, an impurity of major importance, occurs in three principal forms: (1) organic sulfur, (2) sulfate sulfur, and (3) pyritic sulfur. Generally, pyritic sulfur (FeS₂) is the predominant form. Pyrites are of significance in the design of coal refuse disposal facilities because, when exposed to air and water, they oxidize to create acidic conditions that adversely affect the weathering resistance of certain rocks, cause negative environmental impacts, and cause corrosion of some construction materials.

2.1.2 Coal-Related Rocks

The rock formations immediately above and below a coal seam represent a large portion of the material in coal refuse. The character of this rock varies from seam to seam and with the geographic location of an individual coal seam, depending upon the geologic conditions preceding and following the deposition of the coal-forming materials.

Inorganic sedimentary rocks, such as claystone, siltstone, shale, sandstone and occasionally limestone, compose the bulk of the strata where coal is found. These sediments are frequently found in

the coal as inorganic debris deposited during the formation of the organic layer. The most abundant minerals contained in these inorganic rocks are quartz, feldspar, mica (usually muscovite with minor chlorite) and calcite. However, numerous minor components may also be present, and these can vary greatly from site to site. The following sedimentary rocks are listed in an order of decreasing resistance to weathering:

<u>Limestone</u>	A relatively hard, dense rock consisting largely of calcite (CaCO_3). This rock is very durable in the weathering cycle, except in the presence of acid (including acid conditions that result from pyritic sulfur), which will dissolve it.
<u>Sandstone</u>	A rock composed of relatively coarse particles cemented together by calcite, silica (SiO_2) argillaceous material or, less commonly, iron. Its strength and resistance to weathering depend upon the cementing agent.
<u>Siltstone</u>	A rock quite similar to sandstone, except for the generally smaller grain size and substantial amount of clay present. The clay portion is subject to rapid weathering, and high clay content can cause rapid deterioration.
<u>Claystone</u>	A rock composed predominantly of clay-sized particles. It may be massive (mudstone) or fissile (shale) in appearance, but in either case, it has a low resistance to weathering

Iron and sulfur impurities are also common in many coal-bearing sedimentary rocks. As with the coal itself, the most significant of these impurities are the pyrites.

2.2 COAL MINING AND COAL PREPARATION (CLEANING)

Coal is mined in more than 400 coal fields and small deposits in 38 states, split between the Eastern (Appalachian and Interior) and Western regions. In the Eastern region, the quality of raw coal has declined as higher quality reserves have been depleted, requiring more cleaning to meet product requirements. The thicker Western region coal seams typically contain fewer in-seam and out-of-seam rock, and much of that coal is shipped raw without extensive processing (NRC, 2002). Accordingly, coal cleaning and the generation of coal refuse is a significant part of mining projects in the Eastern region, which is where most coal refuse impoundments are operated.

In general, the removal of extraneous materials with the coal during the mining process is controlled by three primary factors: (1) the general geology of the mining area and to a greater extent the immediate type and quality of the floor, partings and roof materials, (2) the thickness of the seam to be mined, and (3) the type of mining equipment selected to remove the coal. For example, in longwall mining where a shearer or cutting head is drawn across the face of a coal seam, a constant thickness of material is removed and will contain roof or floor rock in areas of decreased coal seam thickness. This extraneous material, often referred to as "out of seam dilution," is a major source of coal refuse, particularly in the coarser (> 19-mm) size fractions.

Coal preparation (cleaning) removes refuse from the coal. The preparation technique affects the refuse disposal primarily in three ways: (1) the proportion of coal in the refuse (efficiency of the cleaning process), (2) the gradation of the refuse particles, and (3) the moisture content of the refuse as it leaves the preparation plant. Additionally, the use of flocculants and other chemical additives can also affect the composition of refuse materials. Most modern coal preparation plants today recover coal down to 100-mesh (150-micron) size, and some have incorporated cleaning all of the raw coal. Usually a preparation plant will have either two or three circuits (possibly four if the preparation plant cleans all the way to zero impurities) that handle the distinct size fractions discussed in the following paragraphs.

Often raw coal is processed through a scalping screen or rotary breaker ahead of the preparation plant. This is done to control the maximum size of the raw coal arriving at the preparation plant.

Historically, screening has been done at the 4- to 6-inch size range (100- to 150-mm). Recently, however, the trend has been to reduce the separation size down to as small as 1½ inch (37 mm). This has been done to accommodate the use of the simpler two-circuit coal preparation plant. Depending on the mining method and coal characteristics, the rejected material that must be handled at the refuse disposal site can represent 5 to 15 percent of the raw coal.

Typically, coal preparation plants size raw coal into discrete fractions that are processed separately using various types of process technologies. Currently, heavy media technology is typically used for processing raw coal down to 1 mm. Heavy media vessels (down to 9 mm) or heavy media cyclones (down to 1 mm) or a combination of these two technologies are used to process the plus 1-mm raw coal. The heavy media process involves adding magnetite to water to create slurry with a specific gravity that improves the separation efficiency of the process. The magnetite slurry creates a suspension with specific gravity high enough that the coal floats and the refuse materials with higher specific gravity sink. These types of processes are the most efficient and produce a refuse stream with minimal coal. After the separation of the coal from the refuse, the materials are drained and rinsed of the magnetite media on a vibrating screen. Rinse water is added to the vibrating screen to improve the efficiency of the magnetite removal. Typically, the refuse material discharging from the end of the vibrating screen after being rinsed will have a surface moisture in the range of 8 to 15 percent depending upon the minimum size of the refuse being processed.

The 1-mm by 100-mesh (150-micron) size fraction is typically processed using water-only technologies. Technologies used to process this size range include water-only cyclones, spirals, and hindered-bed settlers. After processing, the refuse materials are typically dewatered using a high frequency dewatering screen designed to retain the plus 100-mesh material. The installation of this type of screen ahead of the thickener can significantly reduce the amount of plus 200-mesh particles in the refuse slurry.

If coal cleaning below 100-mesh size is performed, then typically the differences between the surface chemistry of the coal and refuse are exploited to perform a separation (e.g., froth flotation). Froth flotation requires the addition of a collector (typically fuel oil) and a frother (typically glycol or methylisobutyl carbinol (MIBC)) to the slurry. The fine coal particles are hydrophobic and collect on the surface of the air bubbles created by the flotation machine and rise up through the slurry and are removed with the froth. Alternatives to flotation include high gravity concentrators and fine coal spirals used to process the 100-mesh by 325-mesh (44-micron) size fraction.

Due to the high volume of water used in the processing of coal, thickeners are typically used to reclaim the wash water for recirculation. Generally, the use of flocculants is sufficient to remove the majority of coal fines, but when there are high levels of clay in the mined coal, it may be necessary to also add coagulants. The sequential addition of flocculants and coagulants aids in controlling the turbidity of recycled process water and settling of solids that are pumped to the impoundment.

Technologies for dewatering of the thickener underflow include belt filter presses, vacuum filters, plate and frame filters, solid bowl centrifuges, horizontal belt filters, and paste thickeners. When fines are dewatered, the most commonly used technology is the belt filter press. The dewatered product from these technologies typically has moisture contents in the range of 35 to 45 percent. The amount of minus 325-mesh solids in the feed to these unit operations dictates the final moisture of the product. The higher the amount of minus 325-mesh particles in the feed (which is controlled by the geology and mining method), the more difficult it is for the system to operate and to produce a product with manageable moisture.

If fine refuse dewatering is included in the process, refuse streams must be handled either individually or as a combined product. Amendments may be required for pH control or to aid in the handling

of the refuse products. Depending on the amount of fine refuse and its moisture content, the disposal of the combined product may be difficult.

Prior to 1970, many preparation plants did not attempt to separate coal and impurities in the fine-washed material, resulting in a fine refuse with high coal content. This practice resulted in a relatively high ratio of fine refuse volume to coarse refuse volume, and these disposal sites are of interest for re-mining and recovery of the coal. In general, modern coal preparation plants are more efficient (i.e., lower coal losses to refuse). In addition, the amount of out-of-seam dilution has increased, resulting in higher coarse to fine ratios. This is particularly true in areas where the coal reserve is being depleted. As coal preparation techniques have advanced, the amount of fine coal deposited with the fine refuse slurry has decreased, thus increasing the amount of coarse refuse disposed in relation to the amount of fine refuse.

2.3 REFUSE TRANSPORT AND DISPOSAL PLACEMENT

2.3.1 Coarse Refuse

The method of transporting coarse coal refuse from the preparation plant to the disposal facility is determined by: (1) material gradation, (2) production rate, (3) the distance and topography of the route to the disposal facility and (4) the size, type and configuration of the disposal facility. Although refuse transport methods vary widely, the most common method for transporting coarse refuse is by trucks or scrapers for relatively short distances over moderate terrain, by conveyors for long distances over moderate to steep terrain, or by a combination of these methods. The ramifications of these transport methods on the disposal facilities are further described in Chapter 11.

The placement of coarse refuse at a disposal facility depends upon the method of transport to the disposal facility and the facility configuration. Prior to 1970, coarse refuse transported by truck was generally end-dumped from the truck and allowed to form a progressing embankment at the angle of repose of the material. Another method from that era was to transfer the coarse refuse from a conveyor or continuous bucket tram to an aerial tram that dumped the refuse from a high elevation along a fixed axis, allowing the refuse to form a progressing embankment at the angle of repose of the material except as modified by dozers or scrapers.

Current practice typically includes the use of conveyor systems and/or trucks. Trucks dump the refuse in piles on the disposal surface with subsequent spreading by dozers. If the refuse is transported by conveyor, it is normally dumped into a hopper bin and transferred to trucks or scrapers for placement, as described above. There has been some use of mobile conveyors to deposit coarse refuse directly on the embankment surface for spreading by dozers. The common configurations of coal refuse embankments are described in Chapter 3.

2.3.2 Fine Refuse and Combined Refuse

A common method of transporting fine refuse material has been as slurry pumped to a disposal pond for settling of the solids and clarification of the remaining water. Use of thickeners with the application of flocculants, and in some cases coagulants, improves clarification and settling of solids and facilitates deposition within a slurry impoundment. These additives typically overcome the use of reagents used in the separation and concentration processes of coal preparation.

Another method for transporting fine refuse involves partially dewatering the slurry at the preparation plant. The resulting material is then disposed separately or mixed and placed with the coarse refuse material as combined refuse. There have been many problems associated with transporting and placing the combined material due to the relatively high moisture content of the dewatered fine refuse. Consideration has recently been given to transporting the fine refuse as a paste (thickened

tailings) that can be pumped to a disposal location. The objective in using thickened tailings is to minimize the use of water, generally because of limited availability.

2.4 COAL REFUSE CHARACTERIZATION

Coal refuse is composed of rock fragments, sand, silt and clay particles and contains small amounts of coal not separated during processing.

2.4.1 General Geochemical Characteristics

Coal refuse geochemical characteristics result from the depositional environment of the coal and adjacent strata, the mining and coal preparation process, and the weathering process when the refuse is exposed to air. Coal refuse shares many properties with the coal seam where it originated, with sulfur usually representing the most significant environmental concern. Mining processes may take mine roof and floor materials that contain significant pyrite materials, further affecting sulfur content. Processing of the coal includes crushing, separation, and in some plants recombining coarse and fine refuse. The efficiency of the processing plant at removing sulfur and the degree to which the sulfide fragments are fractured and reduced in size influences the reactivity of the final refuse product. Reagents and additives such as surfactants, oils, and strong bases are used in various separation processes.

Most of the environmental problems associated with coal refuse result from the oxidation of pyrite and subsequent production of acidity. The exposure of coal refuse to weather (air and moisture) enhances the production of acid, leading to a condition of low pH. The pH of a refuse deposit may depend not only on the pyrite content, but also on the length of exposure time and the acid-neutralizing capacity of the refuse. The majority of the coal refuse in the Appalachian region of the U.S. contains an excess of oxidizable sulfur compared to neutralizing carbonates and is therefore net acid producing over time. During the oxidation process, metals are released into soluble forms, resulting in impacts to water quality from drainage through or off the surface of refuse deposits and accumulation of phytotoxic concentrations of acid-soluble metal ions and sulfate salts on refuse surfaces that inhibit the establishment of vegetation during reclamation of the disposal site (Daniels and Stewart, 1993). Western coal regions in the U.S. tend to be less acid producing, but may still pose environmental concerns.

Variability may be found in coal refuse within the same disposal area because: (1) the coal preparation plant may process coal from multiple seams, (2) the process may change over time, and (3) the rate of processing (and thus accumulation and successive covering of earlier refuse deposits) may change due to production and mining factors. The management of refuse at the disposal site can affect the weathering process, with the result that geochemical characteristics can change over relatively short periods of time.

The geochemical characteristics of coal refuse are important planning considerations for coal refuse disposal facilities and can be addressed in a variety of ways. Amendments (additives with neutralization characteristics such as lime products) may be added to provide additional acid-neutralizing capacity that can affect the physical properties of the deposit. Liners (natural soil or synthetic) may be employed for control of seepage from the refuse disposal area and thus will affect foundation requirements and facility configuration.

2.4.2 General Geotechnical Characteristics

Each type of coal refuse has characteristic geotechnical properties. Coarse refuse from the preparation process represents a substantial portion of and sometimes the entire waste stream. Where mechanical crushers are included in the coal preparation process, large-diameter rock (on the order of 6 inches in size and referred to as "breaker rock") may also be generated, although it typically represents a small fraction of the refuse materials.

Fine refuse is a separate waste stream resulting from the wet processing of coal. It may be: (1) disposed as a slurry (fine coal refuse slurry) separate from the coarse refuse, (2) dewatered and disposed with the coarse refuse as combined refuse, or (3) dewatered and disposed separately from the coarse refuse (dewatered fine coal refuse or filter cake). An additional form of refuse, although not common, is the slurring of both coarse and fine refuse (coarse and fine refuse slurry).

Most slurry disposal operations use slurry pumps to transport fine coal refuse at between 5 and 20 percent solids. Thickened tailings are increasingly being considered for fine coal refuse disposal. This practice involves processing the fine coal refuse into a non-settling and non-segregating suspension of solids taking the form of a paste with about 50 percent solids.

2.4.2.1 Coarse Coal Refuse

Coarse coal refuse is typically a well-graded material with particle sizes ranging up to 3 inches and a fines content (as measured by the amount passing the No. 200 sieve or 0.075 mm) ranging from less than 10 percent to more than 20 percent. It is generally classified as a silty, clayey sand with gravel to a clayey, silty gravel with sand. Coarse coal refuse typically has a specific gravity ranging from 1.8 to 2.3, which is lower than many natural soils and aggregates due to the carbon content. Run-of-plant coarse coal refuse generally has a water content of between 8 and 15 percent and loses moisture during transport to the disposal site. As a result, it can readily be compacted to form dense fill in embankments. Figure 2.1 provides the range of grain-size distributions usually encountered for coarse coal refuse at disposal sites and a photograph of a coarse refuse embankment.

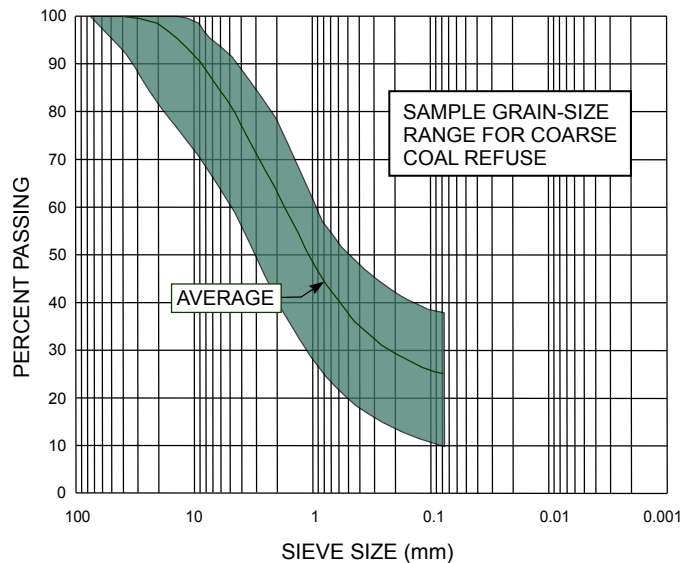

(HEGAZY ET AL., 2004)

FIGURE 2.1 COARSE COAL REFUSE EMBANKMENT AND SAMPLE GRADATION

Coarse coal refuse typically exhibits weathering and some physical degradation during placement and compaction. Thus, the resulting percentage of fines in compacted, weathered coarse coal refuse can be greater than in fresh or recently placed material. Sieve analyses performed on fresh samples before and after compaction have exhibited an average increase in fines content of approximately 4 percent in one northern Appalachian mine. Coarse coal refuse generally has strength, settlement and hydraulic conductivity properties reflective of a well-graded soil and rock fill. Further characterization of coarse refuse is discussed in Chapter 6.

2.4.2.2 Fine Coal Refuse Slurry

Fine coal refuse slurry, when discharged into an impoundment, meanders across previous deposits and the sand-size material commences settling in shallow water. As the slurry discharge velocity

slows and deeper water conditions are encountered, settling of the finer materials occurs, resulting in greater variability in grain size than encountered with other forms of coal refuse placement. Samples collected from or close to the slurry discharge point are predominantly sand- and silt-size material, whereas samples collected away from the discharge point are predominantly silt- and clay-size material. Because the discharge location is typically shifted periodically, there is variability in the grain size of fine refuse materials with elevation as well as location. Figure 2.2 illustrates typical grain-size distributions encountered with discharge of fine coal refuse slurry at impoundments.

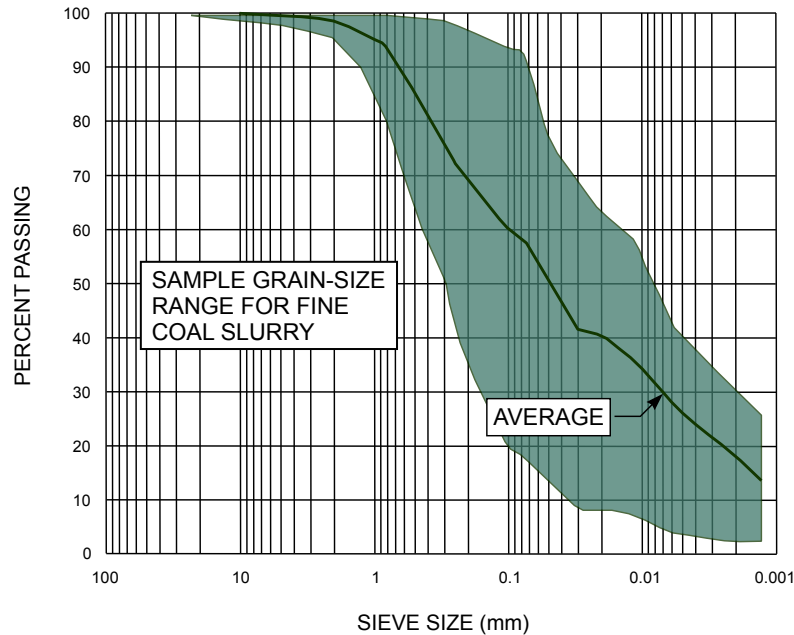

(HEGAZY ET AL., 2004)

FIGURE 2.2 FINE COAL REFUSE SLURRY CHARACTERISTICS

Fine coal refuse consists of particles that are mostly less than 1 millimeter in size and frequently has a fines content (as measured by the amount passing the No. 200 sieve) of typically between 30 and 80 percent. The specific gravity of fine coal refuse tends to be lower than that of coarse refuse, typically in the range of 1.4 to 2.0, depending on the percentage of coal fines. Water content will vary significantly dependent upon the grain-size distribution and location within the impoundment. Settled fine coal refuse slurry has strength, settlement and hydraulic conductivity properties reflective of hydraulically-placed deposits of sand, silt and clay, as further discussed in Chapter 6.

2.4.2.3 Dewatered Fine Coal Refuse

Dewatering of fine coal refuse results in a filter cake material with less variability in grain size than observed in hydraulically-placed fine refuse slurry. While the grain-size distribution is relatively consistent for a given coal seam and processing plant, there is typically variation between samples from different coals and processing systems. Filter cake may have a retained water content in excess of 30 percent, and considering the significant amount of silt and clay fraction in the material, frequently cannot be placed and compacted into an embankment without further drying and/or the addition of other materials such as coarse refuse or amendments for moisture control and stabilization. Consequently, dewatered fine coal refuse is generally disposed with coarse refuse either intermixed as combined refuse or segregated to form containment cells.

2.4.2.4 Combined Coal Refuse

Combined coal refuse is a mixture of coarse and fine coal refuse, and thus has a greater fines content and water content than coarse coal refuse. While still well graded, combined refuse may have fines

content in the range of 20 to 40 percent, and water content between 12 and 30 percent. When the fines and/or water content are relatively high, combined refuse may be difficult to compact into a dense embankment and may also be sensitive to inclement weather impacts. Figure 2.3 presents a photograph of combined coal refuse and an illustration of a typical grain-size distribution for combined refuse with a moisture content of 30 percent.

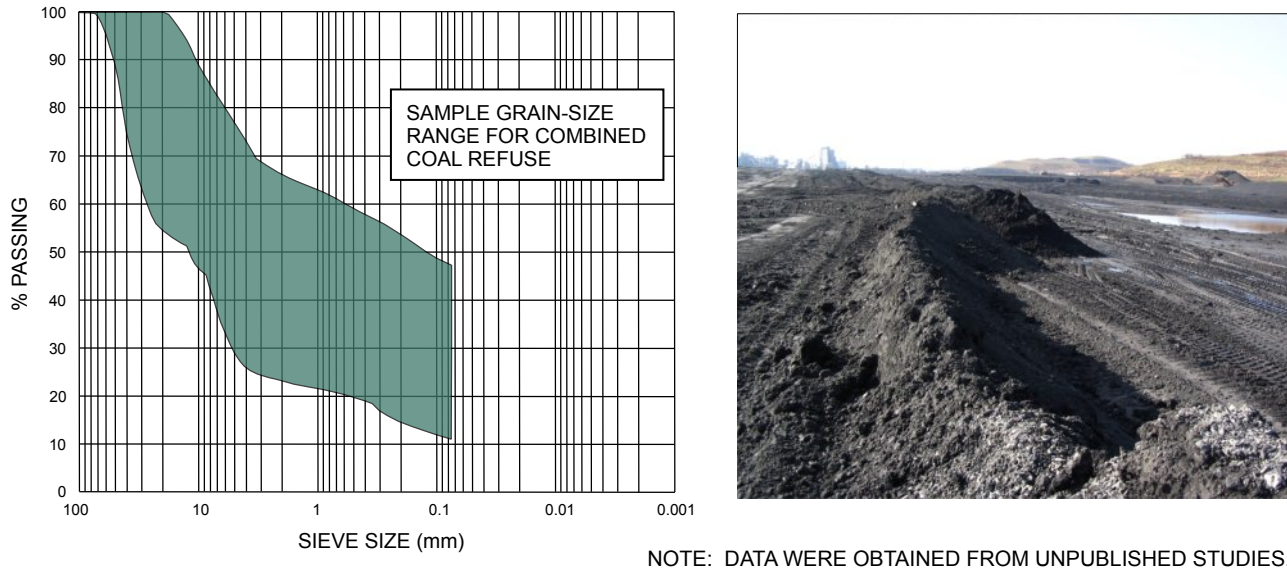

FIGURE 2.3 COMBINED COAL REFUSE MATERIALS

2.4.2.5 Fine Coal Refuse Paste

To reduce the quantity of water associated with fine refuse disposal, thickened tailings technology is currently under study. It is anticipated that the resulting paste will have properties similar to dewatered fine coal refuse from filter presses, but with greater water content. The attraction to this technology lies in certain perceived advantages over filter press operating requirements and the ability to transport the resulting paste by pumping, using less water than required for slurry impoundments. Placement and containment issues are anticipated to be similar to those encountered with disposal of dewatered filter cake. The use of thickened tailings has been implemented at two existing impoundments in the United States (Henry, 2007; Gupta et al., 2008), achieving a paste solids content of 45 to 55 percent that reportedly builds or “stacks” without separation as the paste is deposited.

2.5 DISPOSAL PRACTICES

2.5.1 Disposal Practices Prior to the Buffalo Creek Failure

In February 1972, a coal refuse disposal facility located on a tributary to Buffalo Creek in southern West Virginia failed after several days of rainfall, sending flood water and refuse material through the narrow downstream valley. A number of coal mining communities were devastated, and 125 people were killed. This monumental failure, known as the Buffalo Creek failure, brought the potential danger of similar disposal facilities to the attention of the nation. A summary description of this failure along with other incidents reported at coal refuse disposal facilities is provided in Table 2.2.

Prior to the Buffalo Creek failure, minimal technical effort was devoted to the planning and design of coal refuse disposal facilities in the U.S. Geotechnical and hydraulic characteristics of refuse materials and disposal facilities were seldom considered. Instead, disposal facilities were often developed at

sites chosen for expediency and were often operated with equipment selected by availability rather than suitability for site materials. Most research devoted to coal refuse disposal in the U.S. before 1972 was related to: (1) the prevention of refuse embankment burning, (2) the extinguishment of embankment burning, and (3) the development of vegetation on refuse materials through refuse conditioning and seeding.

Prior to 1972, little or no planning or design was devoted to the control of water entering an impoundment from a preparation plant or from watershed runoff upstream of the disposal facility. Experience had suggested that excess preparation plant water could be clarified naturally by settlement at the impoundment and filtration through the refuse embankment. In most coal refuse impoundments, the water level above the settled slurry reached an equilibrium condition at a depth of less than 10 to 15 feet, at which time the outflow of water from seepage equaled the inflow to the impoundment. This effect, plus the large volume of coarse refuse often placed in the embankment, generally resulted in the maintenance of a large freeboard between the normal water surface and the embankment crest that provided storage for runoff from moderate storms.

The potential risk of coal refuse disposal facilities is related to the storage of water and waste that may be flowable and that, if released, may result in downstream inundation with substantial public safety, economic and environmental consequences. A major reason for emphasizing the potential hazard of disposal facilities with impoundments, as compared to disposal facilities without impoundments, is the large geographical area that may be affected by the rapid release of large volumes of water or waste following embankment failure. Unless a non-impounding embankment is located directly above a populated area such as the disastrous failure in Aberfan, Wales in 1966 (Bignell et al., 1977), or adjacent to a stream where materials movement could block flow, the slippage of such an embankment will cause only localized problems related more to environmental and aesthetic considerations than to public safety. However, embankment failure allowing the rapid release of large volumes of water may cause flooding that is costly not only in terms of miner and public safety, and property and environmental damage, but also in terms of extensive cleanup of the dispersed wet refuse for many miles downstream. In mountainous mining areas complementary industrial, commercial and residential developments are usually located in the downstream valley bottom.

2.5.2 Disposal Practices Subsequent to the Buffalo Creek Failure

Following the Buffalo Creek failure in February 1972, regulations were promulgated for the design of embankment structures, and programs and resources were developed, including the 1975 Manual to assist in design, inspection and construction of coal refuse disposal facilities. Hundreds of existing and planned refuse disposal facilities were upgraded to new and safer standards, and for slurry impoundments, significant emphasis was placed on dam safety.

The various programs and resources have produced the following major, positive results:

- It has been recognized that coal refuse disposal facilities can represent a threat to public safety and the environment, and positive steps toward eliminating these threats in future disposal operations have been taken.
- The principles of geotechnical engineering, hydrology, hydraulics, and dam-safety engineering have been applied to the design and construction of coal industry impoundments to enhance the safety of these structures.
- There is industry-wide recognition of the importance of coal refuse disposal to preparation plant operation, and disposal practices are being incorporated into the feasibility, planning, and management of mine operations.

- Data that contribute to the application of geology, soil and rock mechanics, hydrology, hydraulics, dam engineering and geochemistry technologies to the evaluation and design of disposal facilities have been collected and analyzed.
- Research has yielded important advances in the prediction of the performance of disposal facilities, and areas have been identified where new research is needed for the design and operation of disposal facilities.
- The potential economic benefit of integrating the disposal facility design into the total plan for coal production operations has been demonstrated.

While effective engineering and design measures have been implemented to minimize the potential for failure of coal refuse disposal facilities, incidents have occurred that may be instructive. A summary of these incidents is presented in [Table 2.2](#).

Challenges remain for the coal industry, including the following:

- Advances in mining technology, including the more widespread application of longwall mining systems, increases the potential for subsidence and associated impacts to the overburden strata that must be addressed at disposal facility sites, either as part of siting and new facility design, or to permit mining beneath or adjacent to existing disposal facilities. Additionally, the threat of subsidence from old mine workings at some sites may require evaluation and remedial action.
- Production capacity at mines has continued to increase as a result of larger longwall mining systems and operations with continuous miners, and in some cases more reject material (non-coal rock) is being mined, with a corresponding increase in the generation of coal refuse. This has resulted in larger embankments and impoundments that must accommodate refuse placement at a greater rate.
- Longwall systems and larger mines with high production rates may exhibit variability in the refuse generation rate. Disposal facilities should be planned and designed considering this potential variability.
- Integration of surface mine operations with coal refuse disposal poses opportunities for more efficient construction, provided design issues associated with mine spoil/refuse embankments are adequately addressed.
- Amendments and admixtures have become common, whether as part of operations (transport of combustion ash from power plants to mine sites) or to address environmental requirements (neutralization of acid generation from refuse). These material additions may affect the performance of the refuse embankments and should be considered during the design process.
- Re-mining of existing coal refuse facilities to recover coal has developed into a niche industry. Development plans must be prepared for the safe excavation and removal of coal refuse from disposal facilities while maintaining the original geotechnical and hydraulic design criteria and considering the potential for shutdowns experienced with such operations.
- Slurry impoundments should be designed considering the potential impact of seismic events. While seismic failures of such facilities have not been reported in the U.S., the potential exists at some refuse disposal facilities.
- Multiple regulatory criteria from federal and state agencies with differing perspectives must be accommodated in site selection and design.

TABLE 2.2 COAL REFUSE DISPOSAL FACILITY FAILURES AND INCIDENTS

February 26, 1972: Buffalo Mining Company,
Buffalo Creek, West Virginia

On February 26, 1972, the most destructive flood in West Virginia's history occurred when a coal waste impounding structure collapsed on the Buffalo Creek tributary of Middle Fork. Shortly before 8:00 a.m., the impounding structure collapsed, releasing approximately 132 million gallons of water. The water passed through two more piles of coal waste blocking the Middle Fork. At that time, there were no federal standards requiring either impoundments or hazardous refuse piles to be constructed and maintained in an approved manner.

Around 1957, as part of its surface mining operations, the Buffalo Mining Company (a subsidiary of the Pittston Coal Company) had begun depositing mine waste consisting of rock and coal in Middle Fork. Buffalo Mining constructed its first impounding structure, near the mouth of Middle Fork in 1960. Six years later, it added a second impounding structure, 600 feet upstream. By 1968, the company was depositing more waste another 600 feet upstream. By 1972, the height of this third impounding structure ranged from 45 to 60 feet.

Between February 24 and 26, 1972, the National Weather Service measured 3.7 inches of rain in the area of Logan County and Buffalo Creek. The impounding structure probably failed because foundation deficiencies led to sliding and slumping of the front face of the refuse bank. The waterlogged refuse bank accelerated the failure. The slumping lowered the top of the refuse bank and allowed the impounded water to breach and then rapidly erode the crest of the bank. Upon failure of the refuse bank, the floodwater moved into pockets of burning coal waste.

As result of the flood, 125 people were killed, 1,100 were injured, and more than 4,000 were left homeless. In addition, the flood completely demolished 1,000 cars and trucks, 502 houses, 44 mobile homes, and damaged 943 houses and mobile homes to varying extents. Property damage was estimated at \$50 million.

Source: Davies et al., 1972

August 14, 1977: Island Creek Coal Company,
Boone County, West Virginia

An embankment under construction failed at Island Creek Coal Company's impoundment in Boone County, West Virginia, on August 14, 1977. Heavy rainfall overflowed a temporary diversion ditch, causing the water level in the impoundment to rise. Because the embankment was still under construction, storage capacity had not yet reached the required minimum, and the sudden influx of additional water overtopped the embankment. Meanwhile, the water eroded the embankment, reducing its height 23 feet during a two-day period. During this time, 6.8 acre-feet were released, clogging a drainage pipe downstream.

Source: Owens, 1977

December 18, 1981: Eastover Mining Company,
Harlan County, Kentucky

On December 18, 1981, Eastover Mining Company's Hollow No. 3 combined refuse disposal site failed, releasing about 25 million gallons of saturated coal refuse. The operation, which had been permitted for disposal of coarse coal refuse and dewatered slurry "filter cake" that contained approximately 30 percent moisture behind an embankment 192 feet high, had reached 90 percent of its planned capacity. Several factors contributed to the increased pore water pressure in the dewatered fine refuse zone, including: (1) the filter cake layers had not been allowed sufficient time to dry before additional material was added; (2) layers of filter cake were not completely covered with coarse coal refuse; (3) a stream flowed into the impoundment material, increasing saturation; and (4) material used in construction of the embankment did not allow water to seep out. The failure released a mudflow approximately 5 feet deep that traveled 4,400 feet downstream (500 feet in vertical distance) into the community of Ages, Kentucky. One resident was killed, three houses were destroyed and 30 homes were damaged.

Source: Cannon, 1981

April 8, 1987: Peabody Coal Company,
Raleigh County, West Virginia

On April 8, 1987, a breach developed in the principal spillway pipe in the Lower Big Branch impoundment at Peabody's Montcoal No. 7 complex in Raleigh County, West Virginia. The 36-inch-diameter pipe ran through the impoundment and under part of the embankment at a depth of 55 feet. The rupture released nearly 23 million gallons of water, slurry, and fine coal refuse.

TABLE 2.2 COAL REFUSE DISPOSAL FACILITY FAILURES AND INCIDENTS
(Continued)

The exact cause of the accident was not identified but was probably the result of a combination of factors: (1) Heavy snowfall (16 inches of snow with a rainfall equivalent to 1.9 inches), followed by rapid temperature increases and snowmelt, sent excessive amounts of water through the pipe. (2) Two landslides occurred in the slope above the rupture. Although the relative timing of the landslides and the breach is not known, the slides could have caused the pipe to collapse or separate. (3) Erosion of particles near the pipe connections could have reduced the bearing strength of the pipe. (4) The strength of an "elbow" in the piping may have been exceeded by massive and rapid fluid flow. In addition, a sinkhole that developed from the rupture threatened the stability of the embankment. The sinkhole came within 100 feet of several upstream-constructed additions to the cross-valley embankment before stability was maintained through mitigation of the breach.

The impoundment, upstream from several communities, was rated at the time as high hazard. A 50-mile stretch of Coal River from Montcoal to its mouth at St. Albans was visibly affected, and five water plants were shut down. Although 1,700 customers' water supply was disrupted in the Racine Public Service District, no human injuries or fatalities occurred as a result of this incident.

Source: Owens, 1987

January 28, 1994: Consolidation Coal Company,
Morgantown, West Virginia

On January 28, 1994, a 5-foot earthen berm failed at a slurry refuse impoundment at the Arkwright Mine in Granville, West Virginia. Heavy rain and melting snow resulted in 30 inches of water collecting behind the berm; it was determined that the 4-inch discharge pipe and rock underdrain at the site were insufficient to prevent water accumulation. The incident released 375,000 gallons of water into the town of Granville. Although no one was injured, three residences directly downstream were damaged.

Source: Betoney, 1994

May 22, 1994: Martin County Coal Corporation,
Davella, Kentucky

On May 22, 1994, a breakthrough occurred at Martin County Coal Corporation's Big Hollow slurry impoundment in Davella, Kentucky. Nearly 32 million gallons of black water inundated an abandoned and sealed-off portion of the mine. The breakthrough resulted either from collapse or water penetration of the Coalburg coal seam bordering the impoundment. Slurry had been impounded 32 feet higher than the coal seam's elevation. The mine's 16-inch, concrete-block seals held the black water inundating the mine, but water broke through portal seals and a coal seam outcrop barrier. Although the slurry level dropped by 6 feet, the embankment structure was not damaged, and no injuries or fatalities occurred.

Source: Stewart and Robinson, 1994

August 9, 1996: Lone Mountain Processing Incorporated,
St. Charles, Virginia

On August 9, 1996, there was a breakthrough at Lone Mountain Processing's Miller Cove slurry impoundment. The evening before the failure, approximately 2.75 inches of rain had fallen, and most of it within an hour and a half. Approximately 1 million gallons of black water were released into Gin Creek through an abandoned mine. (Underground mines had operated in areas adjacent to the impoundment from the 1920s to the 1980s.)

Excavation of the breach showed that the leak occurred in an area where available mine maps indicated a barrier of at least 25 feet of solid coal between the outcrop and the underground mine workings. Further exploration revealed that the barrier was in fact less than 2 feet thick. It is believed that hydrostatic pressure from the slurry opened cracks in the coal seam and began a piping-type failure. The thin coal barrier was progressively eroded, allowing slurry to flow uncontrolled into the abandoned mine.

Source: Michalek et al., 1996

October 24, 1996: Lone Mountain Processing Incorporated,
St. Charles, Virginia

On October 24, 1996, a second breakthrough occurred at Lone Mountain Processing's Miller Cove impoundment, but in another area of the abandoned mine. This release was more serious than the event in August 1996 because the water contained more solids. Approximately 6 million gallons of water and slurry exited the abandoned mine into Gin Creek and flowed 11 miles, where it entered the Powell River's North Fork. Reportedly, the river was discolored for more than 40 miles.

TABLE 2.2 COAL REFUSE DISPOSAL FACILITY FAILURES AND INCIDENTS
(Continued)

The failure resulted from two large sinkholes that had developed on the northwestern end of the impoundment. When the site was excavated to locate the breach, it was determined that the slurry had entered through a fracture in the mine roof that coincided with these sinkholes.

Source: Michalek et al., 1996

November 26, 1996: Consolidation Coal Company,
Oakwood, Virginia

On November 26 1996, the Buchanan No. 1 impoundment in Buchanan County, Virginia, failed. In the 1960s, the Kennedy coal seam at the site had been excavated by both surface area mining and underground auger mining. After the impoundment was constructed (1984), another company mining underground in the adjacent drainage area apparently intersected the historic auger mine workings, providing a conduit for the slurry.

Coal refuse and slurry from the impoundment broke into an abandoned underground mine and discharged about 1,000 gallons per minute at its peak through two mine portals into the adjacent North Branch Hollow of the Levisa Fork of the Big Sandy River. There was no detrimental impact on the embankment, and no one was killed or injured.

Source: Michalek et al., 1996

October 11, 2000: Martin County Coal Corporation,
Inez, Kentucky

On October 11, 2000, a coal waste impoundment of the Martin County Coal's preparation plant near Inez, Kentucky, released slurry containing an estimated 250 million gallons of water and 31 million gallons of coal waste into local streams. Reportedly, the failure was caused by the collapse of the slurry pond into underground coal mine workings next to the impoundment. The slurry broke through an underground mine seal and discharged from mine entrances 2 miles apart into two different watersheds (Wolf Creek and Coldwater Fork).

Although no human life was lost, the release killed aquatic life along the Tug Fork of the Big Sandy River and its tributaries. Public water supplies were disrupted when communities along the rivers in both Kentucky and West Virginia shut down water plants to prevent contamination with black water.

Source: Various issues of the *Herald Leader*, the *Courier-Journal*, and the *Charleston Gazette* from 2000 and 2001; National Research Council (2002)

(NATIONAL RESEARCH COUNCIL, 2002)

Chapter 3

COAL REFUSE DISPOSAL FACILITIES AND OTHER IMPOUNDING STRUCTURES

This chapter presents an overview of the types of coal refuse disposal facilities and other impounding structures that are employed at mine sites and provides a discussion of terminology applied to these embankments and impoundments. Refuse disposal facilities are generally classified in the following terms: (1) refuse piles (non-impounding facilities), (2) impounding facilities, (3) slurry cell facilities, and (4) underground injection facilities. Non-impounding refuse piles typically consist of an embankment fill where drainage is directed away from the site without retention. These facilities are employed for disposal of coarse coal refuse and dewatered fine coal refuse.

Impounding facilities have the capacity to retain water, sediment and/or fine coal refuse slurry. Under MSHA regulations, a facility or structure requires an approved impoundment plan when it exceeds a threshold height or has the potential for impounding a threshold volume of water and/or fine coal refuse slurry and/or represents a potential hazard to miners. In practice, MSHA also considers any potential hazard to the public downstream. While not always true, slurry disposal facilities typically exceed impoundment threshold parameters, resulting in their being subject to MSHA impoundment plan regulations. Slurry disposal may also occur in slurry cell facilities that do not exceed the impoundment threshold height or volume. In addition to disposal in embankments, impoundments and cells, fine coal refuse slurry may also be disposed in underground mine workings at underground injection sites.

3.1 HAZARD POTENTIAL FOR DISPOSAL FACILITIES AND OTHER IMPOUNDING STRUCTURES

Coal refuse disposal facilities and other mining impoundments are evaluated relative to their hazard-potential classification, which dictates the design criteria that must be incorporated in their planning, development, and construction. While hazard-potential classification primarily relates to impoundments, it can also be applied to non-impounding facilities where dewatered fine coal refuse may exhibit flowable characteristics after disposal. Consistent with the hazard-potential-classification system and criteria for dams in use by federal agencies (FEMA, 2004a), the three hazard-potential classifications for disposal facilities are as follows:

- Low hazard potential – Facilities where failure would result in no probable loss of human life and low economic and/or environmental losses. Such facilities are usually located in rural or agricultural areas where losses are limited principally to the owner's property or where failure would cause only slight damage to farm buildings, forest and agricultural land, and minor roads.

- Significant hazard potential – Facilities where failure would likely not result in loss of human life, but can cause economic loss, environmental damage, or disruption of lifeline facilities. Such facilities are generally located in predominantly rural areas, but could be in populated areas with significant infrastructure and where failure could damage isolated homes, main highways, and minor railroads or disrupt the use of service of public utilities.
- High hazard potential – Facilities where failure will probably cause loss of human life. Such facilities are generally located in populated areas or where dwellings are found in the flood plain and failure can reasonably be expected to cause loss of life; serious damage to homes, industrial and commercial buildings; and damage to important utilities, highways or railroads.

The purpose of hazard-potential classification is not to determine the likelihood of a failure occurring, but rather to assess the potential impacts should a failure occur and to establish appropriate criteria for use in the design and operation of the facility. Thus, more conservative design and operations criteria apply as the potential for loss of life or property damage from failure increases. For example, more subsurface exploration and material property testing is normally performed for a facility with high hazard potential than for one with low hazard potential. An impoundment dam with high hazard potential would be designed to accommodate the probable maximum flood (PMF), while a dam with low hazard potential would be designed for a smaller storm event. While this chapter introduces hazard-potential classification, specific design criteria that are associated with the hazard-potential classification are discussed in later chapters. The application of the hazard-potential classification to storm water management is discussed in Chapter 5; stability considerations are discussed in Chapters 6 and 7; and hydrology and hydraulic engineering issues are addressed in Chapter 9.

Determination of possible damage due to failure of an impounding refuse disposal facility must be based upon an evaluation of conditions for an appropriate downstream distance. This distance is normally determined by performing a breach analysis that defines an inundation area resulting from a breach of the impounding embankment. This analysis is particularly important in mountainous mining areas where complementary industrial, commercial, and residential developments are usually located in valley bottom. Conditions downstream from the disposal facility may also be important even if the facility embankment is incapable of impounding water. An example is failure of an embankment that blocks a stream, temporarily forming a dam that impounds water that suddenly fails, releasing a flood wave of water and coal refuse.

Many mine impoundments currently under MSHA jurisdiction have underground mine works either beneath or near the dam or reservoir. This creates a situation where a failure of the impoundment may release flowable fine coal refuse and water into the underground mine workings. A release of flowable fine coal refuse and water can also occur due to failure of natural ground or man-made barriers, resulting in breakthrough into the mine workings. In the event of breakthrough, not only will mine personnel potentially be endangered, but the water or slurry may subsequently discharge from the mine and potentially affect an area different from that affected by a dam failure. MSHA addresses this possibility as follows:

- The official hazard-potential classification for an impoundment facility is based on the three classifications discussed previously and is assigned regardless of whether the potential hazard is from a failure of the dam or from a breakthrough into the mine workings and subsequent discharge.
- For the purpose of selecting appropriate design criteria for a coal refuse dam, the hazard classification is based on the appropriate rating for the type of failure con-

sidered. For example, an impoundment could have a high-hazard-potential rating based solely on the potential for breakthrough into the underground mine workings, with low consequences associated with a failure of the dam itself. In such a case, the dam embankment can be designed based on the low-hazard-potential classification (e.g., the 100-year design storm), while the breakthrough evaluation and prevention measures, with respect to the extent of exploration, testing, monitoring, etc., would need to be appropriate for a high-hazard-potential facility.

3.2 COAL REFUSE IMPOUNDMENT FACILITIES

Coal refuse dams are typically designed using coarse refuse and soil or rock fill materials for construction with placement of fine coal refuse slurry in the associated impoundment. The development frequently initiates with a starter dam constructed of earthen materials, coarse refuse or a combination of both for the period of initial slurry disposal. Coarse refuse generated by the coal preparation plant is then used to expand and raise the starter dam, thus providing additional disposal capacity for the fine coal refuse slurry. Typical features and construction practices associated with a slurry impoundment facility include:

- Temporary surface drainage diversion away from areas of embankment dam construction.
- Removal and stockpiling of topsoil and soils for future reclamation.
- Removal of unsuitable foundation materials that would adversely affect the construction of the embankment dam.
- Collection and conveyance of groundwater springs.
- Construction of impoundment and embankment liners, as required by state regulations.
- Construction of the dam and emergency spillway to design grades to provide ample freeboard for design storm runoff storage and discharge capacity.
- Construction of a foundation cutoff, underdrains and internal drainage structures within the embankment dam to control seepage and phreatic surface development.
- Construction of decant pipe structures for removal of accumulated water (surface runoff and/or clarified water) from the impoundment.
- Construction and maintenance of haul roads on the embankment or adjacent areas to transport refuse to the disposal area.
- Grading of the refuse embankment surface to maintain drainage toward collection and/or diversion ditches.
- Grading and sealing of the refuse embankment for drainage control and minimizing water retention on the embankment.
- Collection of surface drainage on the embankment and delivery to sediment control structures.
- Reclamation of completed surfaces such as the embankment downstream face and, at completion of slurry disposal operations, covering of the settled fine coal refuse by evacuating accumulated water, covering the fine coal refuse with coarse refuse or earthen materials, and placement of soil and topsoil, and vegetation.

A significant issue in the development of a slurry impoundment is the design and construction of the starter dam. The size, materials, and hydraulic appurtenances associated with the starter dam impact future operations of the disposal facility, require substantial engineering oversight during construction, and can represent a significant part of the development cost for the facility. The sched-

ule for construction of a starter dam for a new mine is normally critical, as the coal preparation plant will not usually be able to operate at full capacity until there is a functioning slurry disposal area that meets initial short-term design storm criteria. The starter dam must also be designed so that it can be transitioned to meet long-term criteria. For existing preparation plants, the designer should coordinate the closure of an existing impoundment with the activation of a new impoundment to avoid lapses in available refuse disposal capacity and to facilitate reclamation of completed areas.

Coarse refuse embankment dams are usually large in cross section in order to accommodate the production of refuse from the preparation plant. They may be constructed either as a homogeneous or zoned embankment. If an embankment dam is constructed as a zoned embankment, it may be built with earthen materials of finer gradation in upstream areas of the cross section and with coarse refuse in downstream zones. While the term homogeneous is often applied to coarse refuse embankment dams, the coarse refuse may exhibit variability in grain size and specific gravity, but still have adequate shear strength to meet design assumptions and be sufficiently competent to support construction equipment.

3.2.1 Size and Hazard Considerations

3.2.1.1 Impoundment Definition

MSHA currently requires that plans be prepared and approved for the design, construction, operation and maintenance of structures that impound water, sediment or slurry if such structures:

- Impound water, sediment, or slurry to an elevation of 5 feet or more above the upstream toe of the structure and have a storage volume of 20 acre-feet or more; or
- Impound water, sediment, or slurry to an elevation of 20 feet or more above the upstream toe of the structure; or
- Are determined by the MSHA District Manager to present a hazard to coal miners.

For purposes of determining inclusion under MSHA regulation, the height of an embankment dam is measured from the upstream toe of the structure to the lowest point on the crest of the dam. Other regulatory agencies may define height differently. [Figure 3.1](#) illustrates this measurement for a cross-valley impounding embankment. If the lowest point on the crest of the structure is the invert of a properly designed open-channel spillway capable of conveying the maximum water flow from the design storm with sufficient freeboard and erosion protection, then that point is the proper location for the upper measurement. Where decant pipes and pipe/box spillways are used, the elevation must still be measured to the lowest point on the crest of the structure or embankment, not to the invert of the decant riser or spillway pipe.

The storage volume of a dam is calculated using either the invert elevation of the spillway or the lowest point on the crest of the structure. However, the storage volume based on a measurement to the invert of the spillway may only be used if two conditions are satisfied. First, the spillway must be an open-channel configuration. Second, the open-channel spillway must be designed to convey the flow from the design storm with adequate freeboard and must have appropriate erosion protection. If either of these requirements is not met, the capacity of a dam must be determined based on a measurement made to the lowest point on the crest of the structure without reference to the spillway. The design of the open-channel spillway can be verified using a flood routing analysis of the design storm (selected based on the purpose of the structure and projected hazard potential classification) through the impoundment's open-channel spillway and other outlet works (if applicable).

Small ponds are sometimes used for disposal of fine refuse slurry and are referred to as slurry cells. These cells may be located within an embankment and sized and sequenced to preclude classification

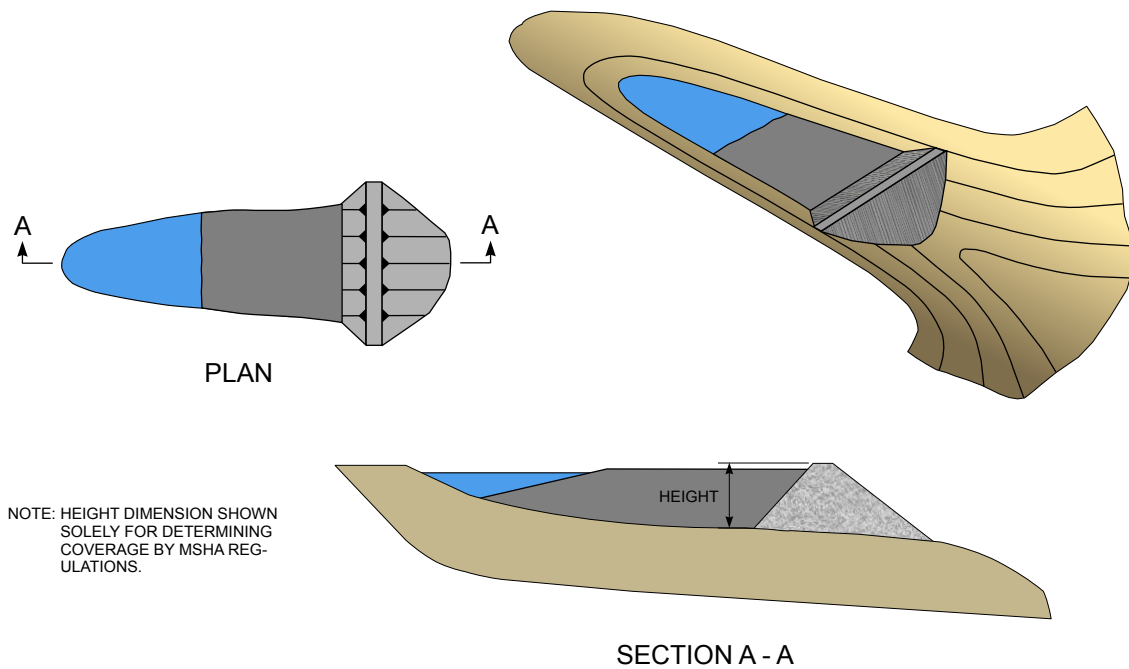

FIGURE 3.1 CROSS-VALLEY IMPOUNDING EMBANKMENT

of the embankment as an impoundment. However, there are also situations where the slurry cells are of sufficient size and are operated such that the facility may be classified as an impoundment. [Section 3.4](#) addresses slurry cell facilities. If a pond or impoundment meets any of the preceding criteria, the facility is subject to regulation by MSHA as an impoundment. It is important to note that state regulatory agencies may define structures that are regulated as dams using different dimensions or definitions.

3.2.1.2 Impoundments in Series

In the case of multiple impounding structures in series that individually do not meet the size criteria cited in [Section 3.2.1.1](#) and where a failure of one of these structures can result in the failure of another, the cumulative storage capacity should be used when applying the impoundment size criterion.

In the case of multiple slurry cells (addressed separately in [Section 3.4](#)) that individually do not meet the size criteria cited in [Section 3.2.1.1](#) and where failure of one slurry cell can lead to the failure of others, or where a slope failure can result in the release of water, sediment or slurry from multiple cells, the cumulative capacity of the potentially affected cells should be used when applying the impoundment size criterion.

3.2.1.3 Incised Impoundments

An incised impoundment is one created by excavating below the natural ground surface, as illustrated in [Figure 3.2](#). An impoundment may be totally below natural ground, or an embankment may be constructed so that only a portion of the impoundment is below natural ground. For purposes of determining the height or storage volume of an impoundment with respect to the criteria presented in [Section 3.2.1.1](#), the portion contained below natural ground is not included in the height or storage volume calculation. However, even for an incised impoundment, if it is determined that the impoundment could become a hazard, appropriate design and construction requirements should be implemented. In situations where mining is planned or occurs near an incised impoundment, mine operators should be sure that there is a sufficient thickness of undisturbed ground left in place to preclude failure.

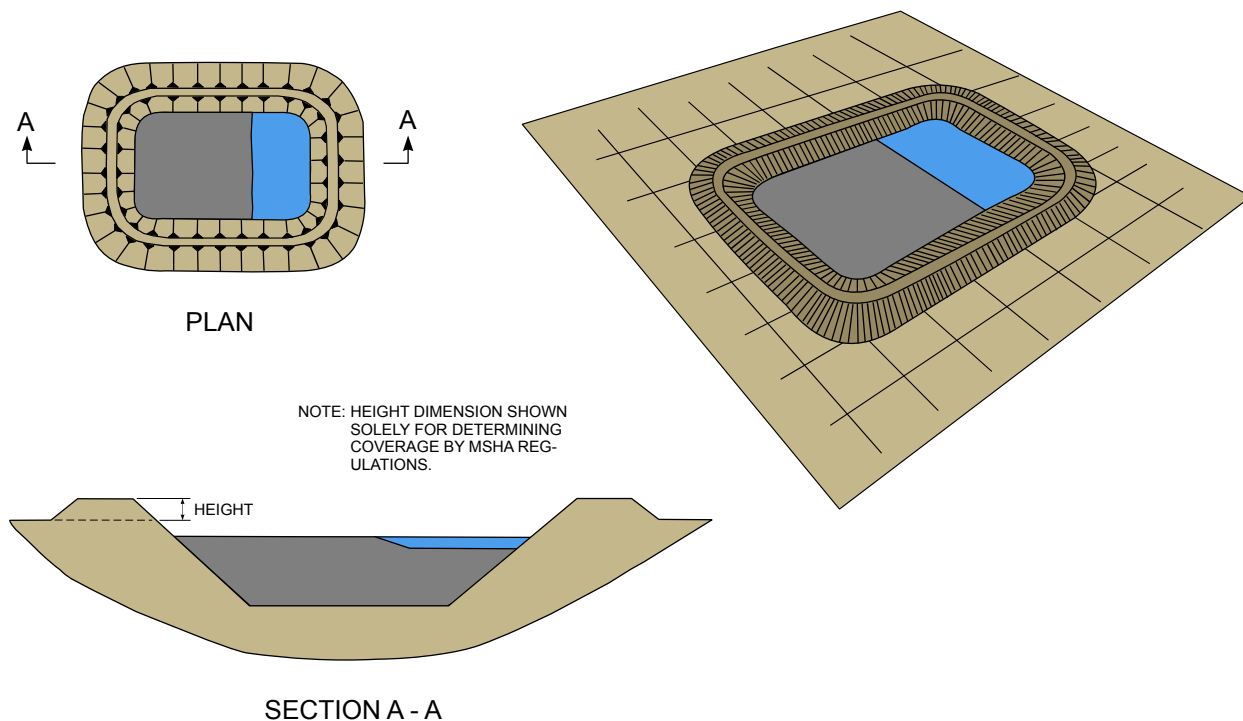

FIGURE 3.2 INCISED IMPOUNDING FACILITY

Cases may arise where a surface mining pit is used as an impoundment. If any portion of the ground creating the impoundment is mine spoil or fill, then that portion should not be considered to be incised (MSHA, 2007).

3.2.2 Disposal Facility Configuration

Impounding coal refuse disposal facilities are classified based on their configuration and development/construction staging. The disposal facility configuration is dependent upon the terrain and size requirements, and the development staging reflects the general sequence or direction of disposal activity. The facility configuration categories are: (1) cross-valley impounding embankment (Figure 3.1), (2) incised impoundment (Figure 3.2), (3) side-hill impounding embankment (Figure 3.3), and (4) diked impounding embankment (Figure 3.4).

Planning and design of an impounding embankment generally involves distinct development/construction stages that are associated with intermediate points in the facility construction and the general timing and directional development of the disposal operations. These stages typically reflect a few months to a few years of disposal operation and usually reflect the direction in which development occurs. The direction of construction normally falls into two categories: upstream and downstream. Upstream construction, as shown in Figure 3.5, involves initial construction and placement of coarse refuse in downstream areas to form the impoundment with sequential placement during subsequent stages in upstream locations, typically at higher elevations. Downstream construction, as shown in Figure 3.6, involves initial construction and placement of coarse refuse in upstream areas with placement during subsequent stages in downstream locations. It is common to have both upstream and downstream construction stages as part of a disposal facility design.

An intermediate development condition is centerline construction (which is essentially the same as alternating upstream and downstream construction), where refuse stages are constructed both upstream and downstream of the previous stage, with the crest of the two stages generally in alignment, but separated by the elevation increment of the stage (Figure 3.7). This terminology for

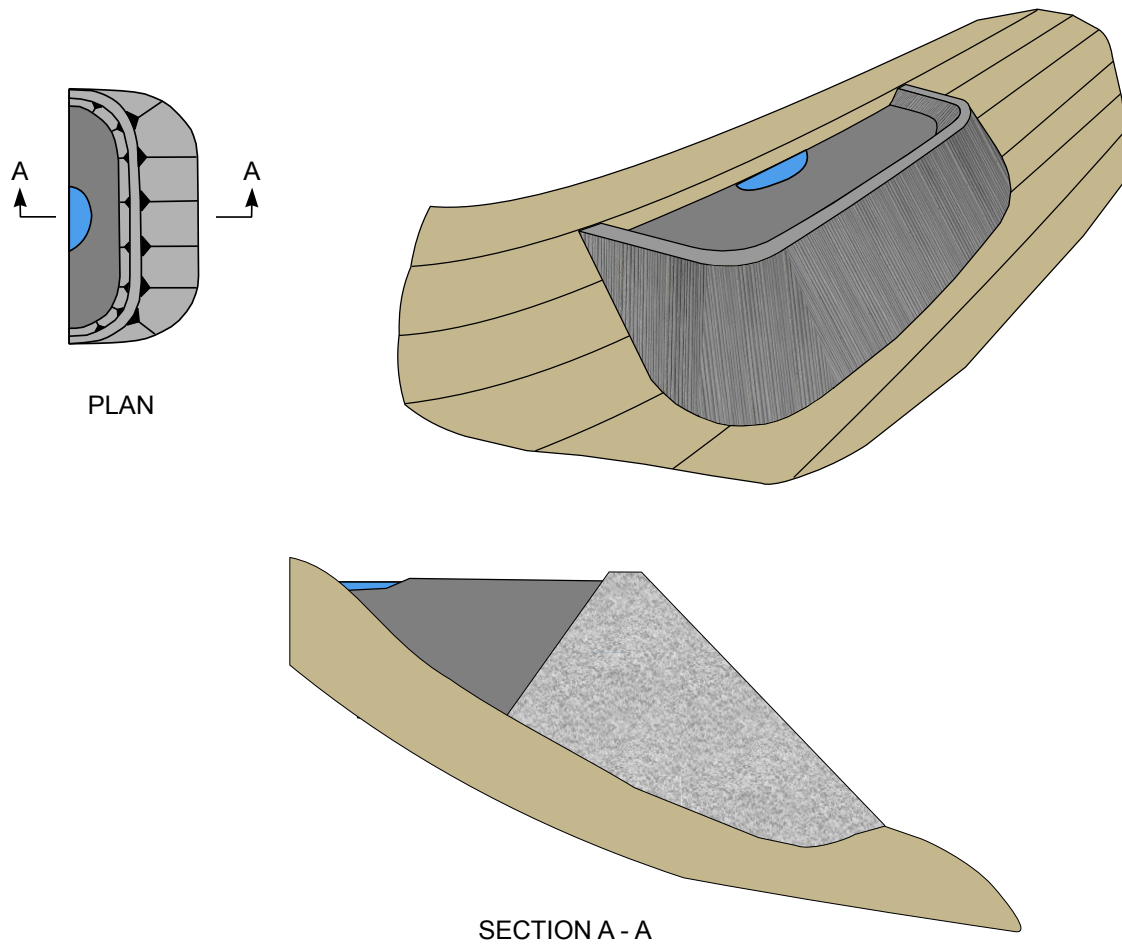

FIGURE 3.3 SIDE-HILL IMPOUNDING EMBANKMENT

impounding embankments is relevant primarily for identifying whether portions of the coarse refuse embankment will be constructed on settled fine coal refuse slurry and the timing for reclamation of completed surfaces of the embankment.

Upstream construction, and to a lesser degree centerline construction, with placement of coarse refuse embankments on settled fine coal refuse, introduces stability concerns due to the potentially low strength of the fine coal refuse during initial covering and the potential for seismically-induced strength degradation. The field exploration, testing and analysis, and design methodology and criteria used for upstream construction plans are typically more extensive than for downstream or centerline construction. On the other hand, upstream construction, when the final toe and lower elevations of the embankment face are established early in the disposal facility development, allows concurrent reclamation of the completed face and thus improved erosion and sediment control.

Downstream construction mitigates issues related to the stability of the embankment due to the soft foundation conditions associated with fine refuse, but the reclamation of the embankment face is delayed until much later in the facility life, thus requiring more comprehensive erosion and sediment control measures.

At some sites, both upstream and downstream stages are constructed in order to: (1) fit site terrain conditions, (2) meet disposal capacity requirements, and (3) provide multiple coarse refuse dis-

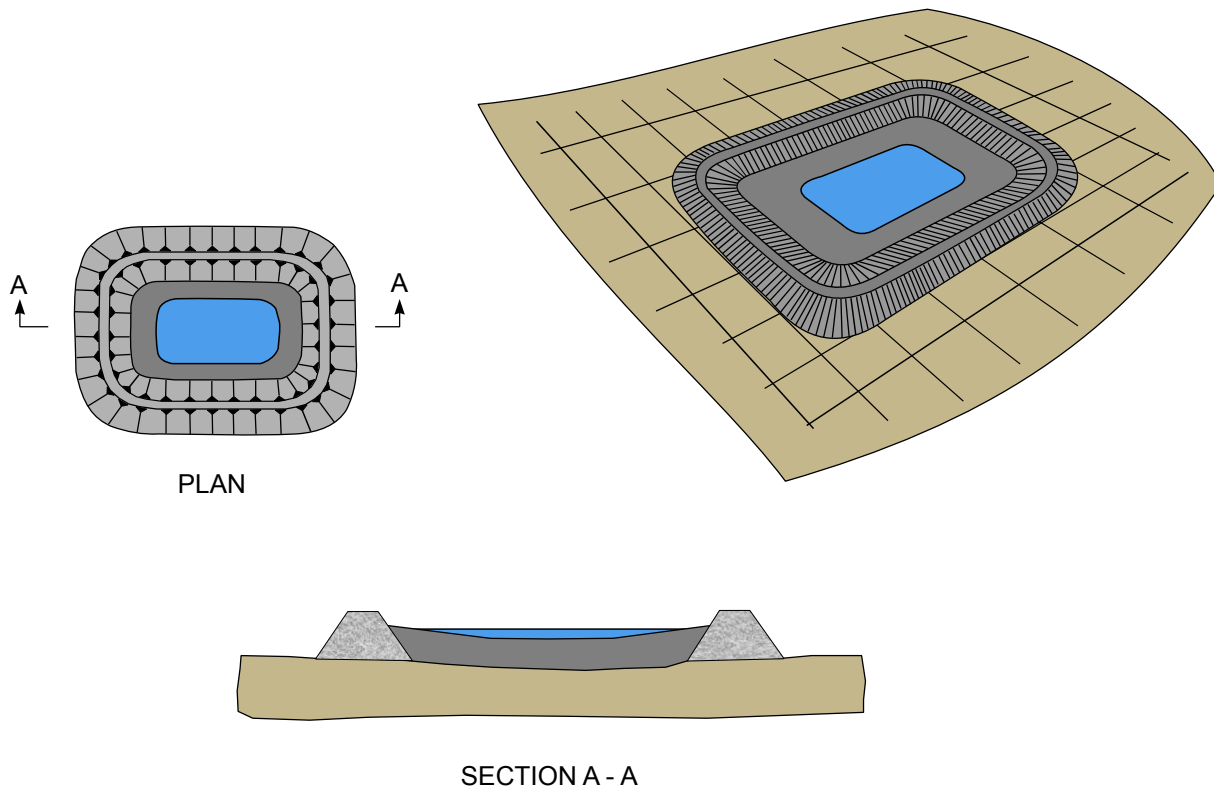

FIGURE 3.4 DIKED-POND (IMPOUNDING) EMBANKMENT

posal areas. This type of construction is sometimes referred to as the modified upstream construction method. Thacker (1997) recommends initiating upstream construction early in the project life, with subsequent placement of coarse refuse in a downstream buttress zone to allow pore pressure to dissipate in the previously loaded fine refuse.

The decision whether to construct a refuse facility utilizing upstream, downstream and centerline construction sequencing is also dependent upon the geometry of the valley and the refuse disposal capacity requirements. For instance, downstream construction generally requires use of greater quantities of coarse refuse to gain embankment elevation than upstream construction. Centerline construction normally requires a greater amount of coarse refuse during the initial stages of the facility with lesser amounts required as construction progresses. Additional discussion of the advantages and disadvantages of various types of embankment construction is provided in Chapter 5.

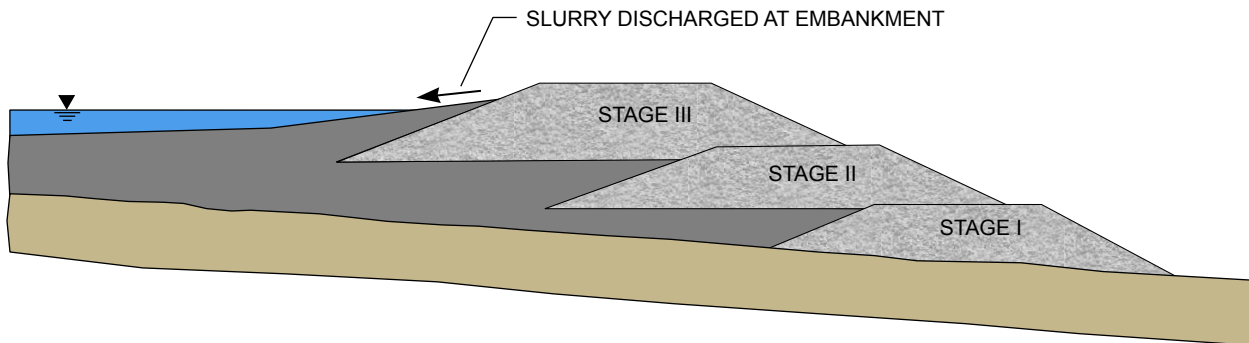

FIGURE 3.5 UPSTREAM STAGING METHOD

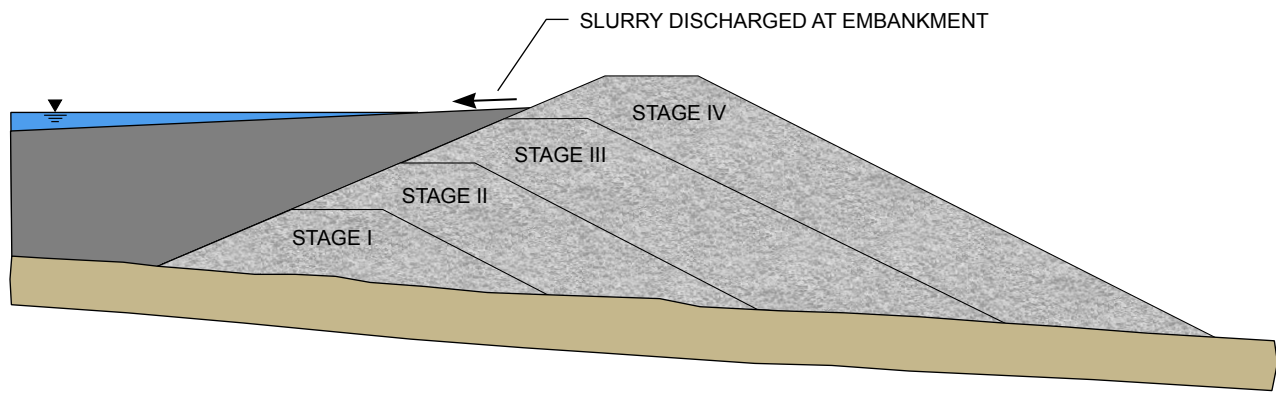

FIGURE 3.6 DOWNSTREAM STAGING METHOD

3.2.3 Hazard Potential Rating

The determination of the hazard-potential classification for impoundments discussed in [Section 3.1](#) is based on the probable loss of life in the downstream area and the presence of structures and infrastructure that could be affected if the dam were to fail. It may be apparent from the presence of nearby, downstream mining facilities or off-site occupied structures that a dam failure could result in loss of life and that the classification should be high hazard. Since this is the most severe hazard classification, no further analyses may be necessary for hazard potential determination, although the evaluation of potential downstream impacts would still be required for preparation of an emergency action plan. If the hazard potential classification is not apparent, dam breach analyses should be performed, with evaluation of the resulting flood inundation levels and flow velocities at downstream structures to determine the potential for loss of life and severity of impact to structures and infrastructure. Dam breach analyses are discussed in [Section 9.9](#).

The assignment of high hazard potential principally hinges on the determination of probable loss of human life. In situations where there is no probable loss of human life due to the dam failure, other site-specific factors are applied to determine the hazard potential. Estimates of economic loss and damage to infrastructure can be generated to provide guidance in differentiating between low and significant hazard, but assessment of environmental damage is more controversial.

Where there are mine workings beneath or near a refuse embankment or impoundment, a release of water and slurry into the mine could result due to failure of the natural ground or a man-made barrier between the impoundment and mine workings. Such a potential failure is referred to as an

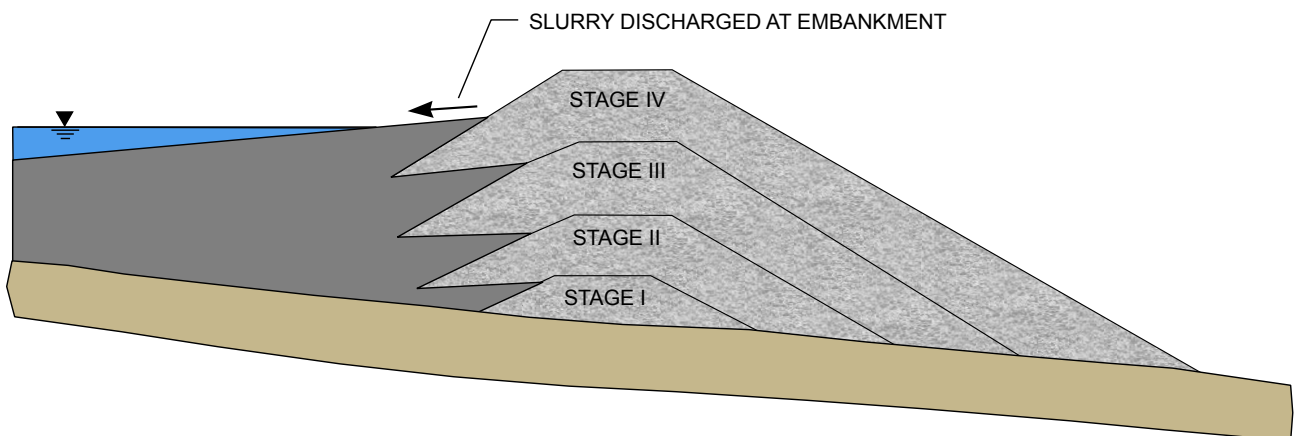

FIGURE 3.7 CENTERLINE STAGING METHOD

impoundment breakthrough and not only poses a threat to mine workers, but the water and slurry could discharge from the mine and potentially affect an area different from the one that would be affected by a dam failure. Chapter 8 addresses the design requirements for this situation, and MSHA (2007) provides the following guidance on hazard potential classification:

- The official hazard-potential classification for an impoundment is based on the three classifications indicated in Section 3.1 and is assigned regardless of whether the potential hazard is from a failure of the dam or a failure into mine workings.
- For the purpose of selecting the appropriate design criteria for the impounding embankment, the hazard-potential classification is based on the appropriate rating in the event of a failure of the embankment itself. For example, an impoundment could have a high-hazard-potential rating based solely on the potential for a failure into underground mine workings, but have low consequences due to a failure of the dam itself. In such case, the dam can be designed based on low hazard potential (e.g., the 100-year design storm), while the breakthrough evaluation and prevention measures (with respect to the extent of exploration, testing, monitoring, etc.) must be appropriate for a high-hazard-potential site.

3.3 COAL REFUSE NON-IMPOUNDING FACILITIES (REFUSE PILES)

Coal refuse disposal facilities that do not retain water or slurry are considered to be non-impounding structures and are also referred to as refuse piles. As indicated in the *MSHA Coal Mine Impoundment Inspection and Plan Review Handbook* (MSHA, 2007), a refuse pile may have small isolated sediment control facilities and cells for the disposal of filter cake, sediments, etc. provided that the size of these cells would not result in the classification of the structure as an impoundment, their location would not affect structural stability, and the configuration does not impede drainage (e.g., block a drainage course). Where this material is not compacted in two-foot lifts, the disposal should be approved by the MSHA district manager. In addition to filter cake, fine coal refuse slurry can also be disposed in appropriately designed cells, as discussed in [Section 3.4](#).

3.3.1 Coarse Refuse Embankments

If not part of an impoundment plan, a coarse refuse embankment is typically designed for separate disposal of coarse coal refuse and fine coal refuse. Typical features and construction practices associated with a coarse refuse disposal facility include the following:

- Surface drainage diversion away from the limits of the disposal embankment.
- Removal and stockpiling of topsoil and soils for future reclamation.
- Removal of unsuitable foundation materials that would adversely affect the construction or stability of the embankment.
- Collection of discharges from springs under the foot print of the embankment that may adversely affect stability.
- Placement and compaction of run-of-plant coarse refuse in lifts to the designed lines and grades of the embankment.
- Construction and maintenance of haul roads on the embankment for transporting the refuse to the disposal area.
- Grading and sealing of the refuse embankment to maintain drainage control and to prevent water retention behind the embankment.
- Collection of surface drainage on the embankment and delivery to sediment control structures.
- Reclamation of completed surfaces, consisting of placement of soil and topsoil and re-vegetating.

Coarse refuse embankments are usually developed as homogeneous embankments, without multiple zones. While the term homogeneous is applied to such embankments, the coarse refuse materials may exhibit some variability in grain size and specific gravity. Typically, however, coarse refuse has the strength to support construction equipment and to meet the embankment design assumptions.

3.3.2 Combined Refuse Embankments

Combined refuse embankments are designed for disposal of coarse refuse and dewatered fine coal refuse as a mixed material. While combined refuse embankments may be homogeneous, they can also be constructed as zoned embankments where more workable refuse materials such as coarse refuse are used (either periodically, or in sufficient continuous quantity) to construct a well-compacted downstream shell of sufficient width (sometimes referred to as a structural zone) to contain the combined refuse and to construct haul roads within the disposal area. Typical features of a combined refuse disposal facility are similar to those for a coarse refuse embankment. Because of the presence of dewatered fine coal refuse and overall wetter material conditions, large disposal areas are generally needed so that the dumped materials can drain before spreading and compaction, and more extensive internal drainage systems may also be required. In some cases amendments may be needed to stabilize the wet materials.

3.3.3 Segregated Refuse Embankments

Dewatered fine coal refuse can be disposed in segregated areas of a coarse refuse embankment. This approach results in a zoned embankment in which coarse refuse forms a downstream zone or shell that supports the overall stability of the embankment, and isolated areas are provided within the upstream or interior of the embankment for depositing the dewatered fine coal refuse. Typically, these segregated refuse embankments are designed with provisions for haulage routes within the embankment and for containment of the dewatered fine refuse without creating depressions that could be classified as impoundments. Such containment structures require measures to control surface drainage that collects in the dewatered fine refuse disposal area. Typical features of segregated refuse embankments are similar to those for coarse refuse embankments, but with more extensive internal drainage systems and control of drainage within the dewatered fine refuse containment area.

3.3.4 Configuration and Development Staging

Non-impounding facilities are constructed with a range of configurations and development staging. The disposal facility configuration depends upon the terrain, and the development staging reflects the general sequence or direction of disposal activity. Non-impounding facility configuration categories are: valley-fill (Figure 3.8), cross-valley (Figure 3.9), side-hill (Figure 3.10), ridge-dump (Figure 3.11), and heaped (Figure 3.12).

Planning and design of a non-impounding embankment generally involves development stages related to intermediate points in the facility construction and the general development direction of the disposal operations. The development staging is characterized by the direction in which development occurs. Upstream construction involves the construction and placement of refuse in downstream areas initially, with sequential placement during subsequent stages in upstream locations, typically at higher elevations. Downstream construction involves the construction and placement of refuse in upstream areas initially, with sequential placement during subsequent stages in downstream locations. This terminology for non-impounding embankments is more relevant for valley-fill configurations, where upstream and downstream directions reflect the shape of the valley.

Cross-valley non-impounding embankments (Figure 3.9) can potentially impound water, and they may be classified as impoundments by MSHA if they can impound water for such a period

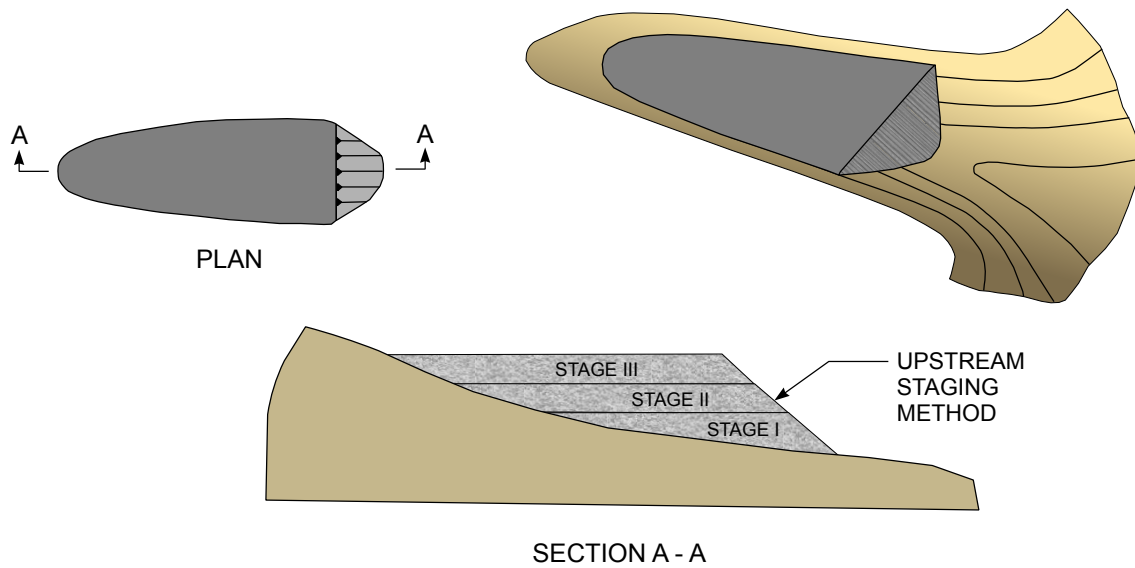

FIGURE 3.8 VALLEY-FILL, NON-IMPOUNDING EMBANKMENT

of time that they can create a hazard. MSHA (2007) presents factors considered for such classification. Abandonment of cross-valley non-impounding embankments can require substantial regrading in order to satisfy long-term drainage concerns. Therefore, this type of embankment is generally avoided.

3.4 COAL REFUSE SLURRY CELL FACILITIES

Small cells or ponds in a coarse refuse facility that receive fine refuse are commonly referred to as slurry cells. Disposal of fine coal refuse using slurry cells has been implemented at sites where con-

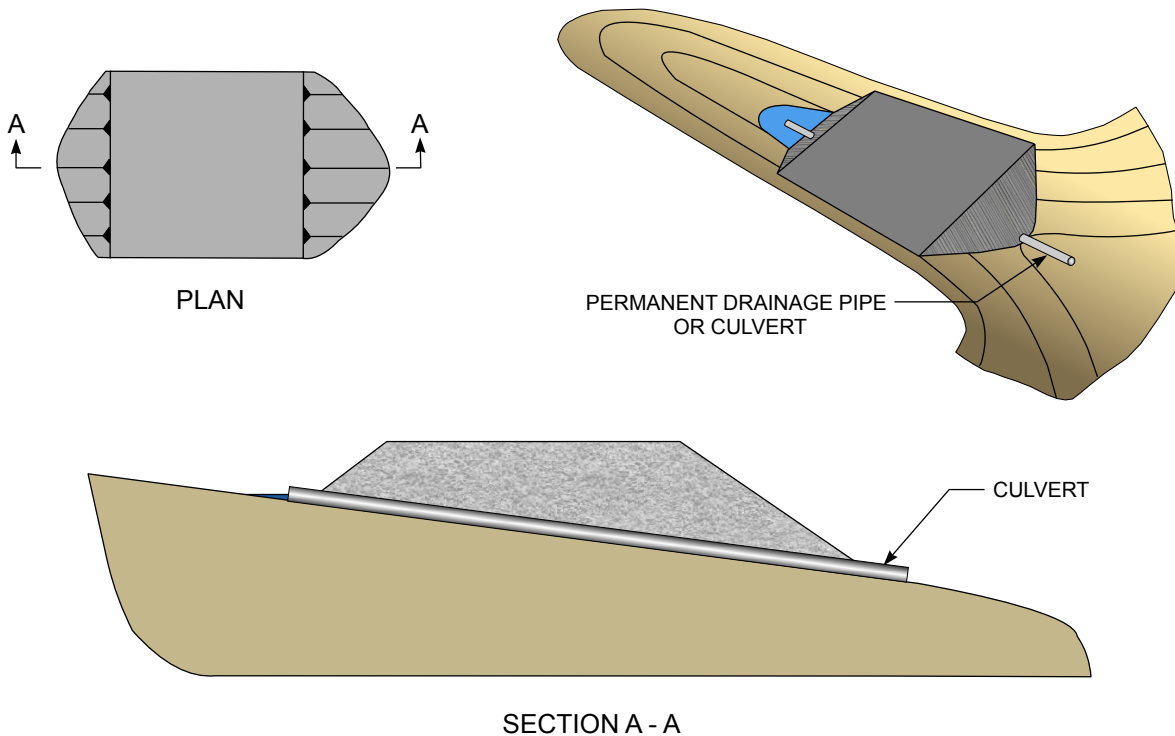

FIGURE 3.9 CROSS-VALLEY, NON-IMPOUNDING EMBANKMENT

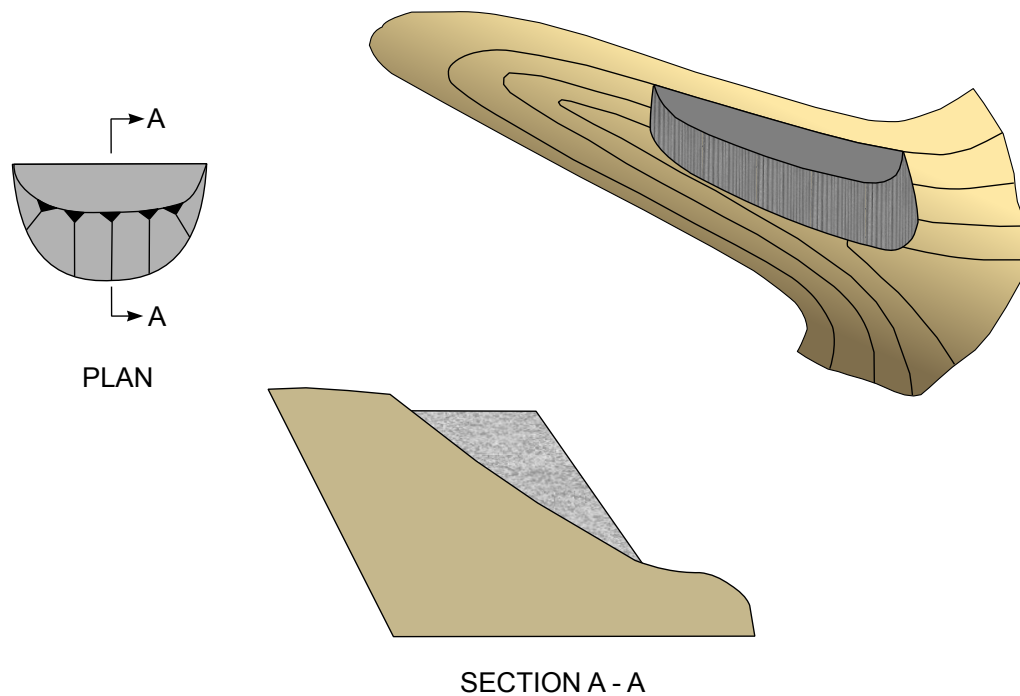

FIGURE 3.10 SIDE-HILL, NON-IMPOUNDING EMBANKMENT

straints may deter or preclude the construction of a large slurry impoundment, and/or the quantity of fine coal refuse slurry is relatively small and can be reasonably accommodated with a small cell structure. Small cells are created, usually within the upstream zone of a coarse refuse embankment, and are filled with slurry. The upstream zone and cells are contained by a well-compacted downstream shell (sometimes referred to as a structural zone). Once an individual cell is filled, it is allowed to drain, and the fine coal refuse is covered with coarse coal refuse while another cell is operated. Because of the typical small cell size, operation of multiple cells intermittently will facilitate settling and draining of fine refuse and optimize the capacity of each cell.

Slurry cells may also be used to dewater fine refuse prior to final disposal. Instead of encapsulating the slurry cell in a coarse refuse embankment, the fine refuse is excavated from the cell after substantial dewatering has taken place and then is typically mixed with coarse refuse prior to being incorporated into an embankment for final disposal.

3.4.1 Size and Hazard Classification

The slurry cell concept is typically focused on: (1) sequencing the construction of cells to match the slurry generation rate, (2) accommodating drainage and covering of each cell, and (3) maintaining a total capacity of all open cells at a level that does not meet impoundment classification or, if classified as an impoundment, has a low hazard potential. In the case of multiple slurry cells where they individually do not meet the size criteria requirements of 30 CFR § 77.216(a), if the failure of one cell can result in the failure of another or if a slope failure can result in the release of water, sediment, or slurry from multiple cells, then the cumulative storage capacity of the affected cells is used for application of the impoundment size criteria. This includes cases where the initial slurry cells are covered with coarse refuse and additional cells are to be placed above the initial set of cells (MSHA, 2007).

The operation of multiple cells, particularly if subsequent cells are built on previously covered cells similar to the upstream construction method for an impoundment, can lead to classification as an impoundment. If multiple cells are arranged such that they affect structural stability and there is a possibility of sequential failure and a large release with significant downstream impacts,

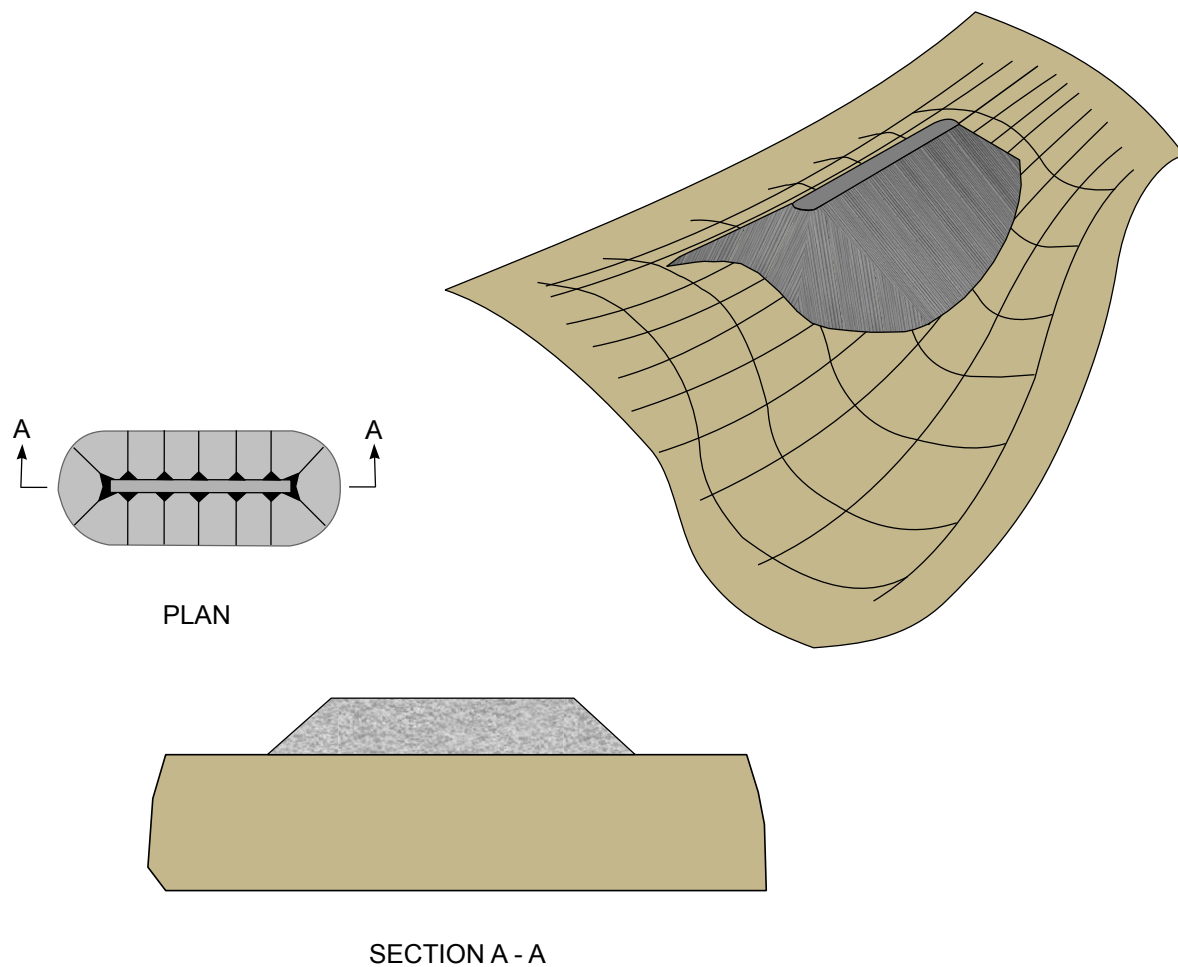

FIGURE 3.11 RIDGE (NON-IMPOUNDING) EMBANKMENT

the impounding facility could receive a significant- or high-hazard-potential classification, as discussed in [Section 3.1](#). In such a case, the design storm requirement will increase, necessitating greater diversion and freeboard, thus limiting the feasibility of the concept for some configuration categories (e.g., valley fills).

The advantages of the slurry cell concept are the following:

- As a low-hazard-potential facility with limited cell size, managing the design storm runoff can generally be accommodated with minimal storage, enabling more capacity for disposal of slurry and clarification of process water. Control of surface drainage from the surrounding embankment area is critical, along with effective diversion of runoff from watershed areas around the facility.
- Slurry cells have limited capacity, comprising generally a thin deposit of slurry with coarse refuse containment and covering layers that allow the fine refuse to dewater and consolidate, making the total mass less flowable. This limited capacity is viewed as an advantage at sites that are undermined and have the potential for breakthrough.
- With the fines compartmentalized in cells, a problem at one location is less likely to affect the entire facility, which also helps to mitigate concerns for breakthrough potential.

- As a low-hazard-potential facility, fewer and less extensive hydraulic appurtenances are required, with lower associated construction costs.

The features of a slurry cell facility are similar to those discussed for a non-impounding facility. It has become common practice to design a well-compacted shell (sometimes referred to as a structural zone) at the face of the disposal facility embankment as the downstream containment structure for cells. The design of the well-compacted shell is based upon evaluation of factors such as width, slope, benches, internal drainage, and access or haul roads. Similar to non-impounding refuse embankments, diversion of runoff from upstream and hillside areas is accomplished by locating ditches and channels, which are separate structures from the slurry cells, either above or on the embankment surface. To keep runoff from entering the disposal area, the construction and maintenance of the diversion ditches requires sequential planning and periodic construction activities apart from disposal operations. Additionally, control and discharge of process water from the slurry operation is required at each cell. Typically, this will require small-diameter decant systems or stabilized channels. These structures usually have limited service requirements because of the low capacity of the cells.

In addition to the critical sequencing of cells to match the fine refuse generation rate and maintain low-hazard-potential classification, a slurry cell facility has many of the same design considerations as impoundments: (1) geotechnical investigation to determine embankment and foundation characteristics, (2) testing for relevant material properties including shear strength and hydraulic conductivity, (3) static and seismic slope stability analyses, (4) underdrains to control the phreatic level, (5) a dam breach analysis, unless the hazard potential is otherwise apparent, to determine the appropriate hazard potential rating and design storm, (6) instrumentation to confirm design assumptions and performance, (7) preparation of construction specifications, and (8) construction monitoring.

Some disadvantages of slurry cell facilities include requirements for: (1) frequent construction of diversion ditches, new cells, and cell spillways (decant structures) as the site elevation increases, (2) a

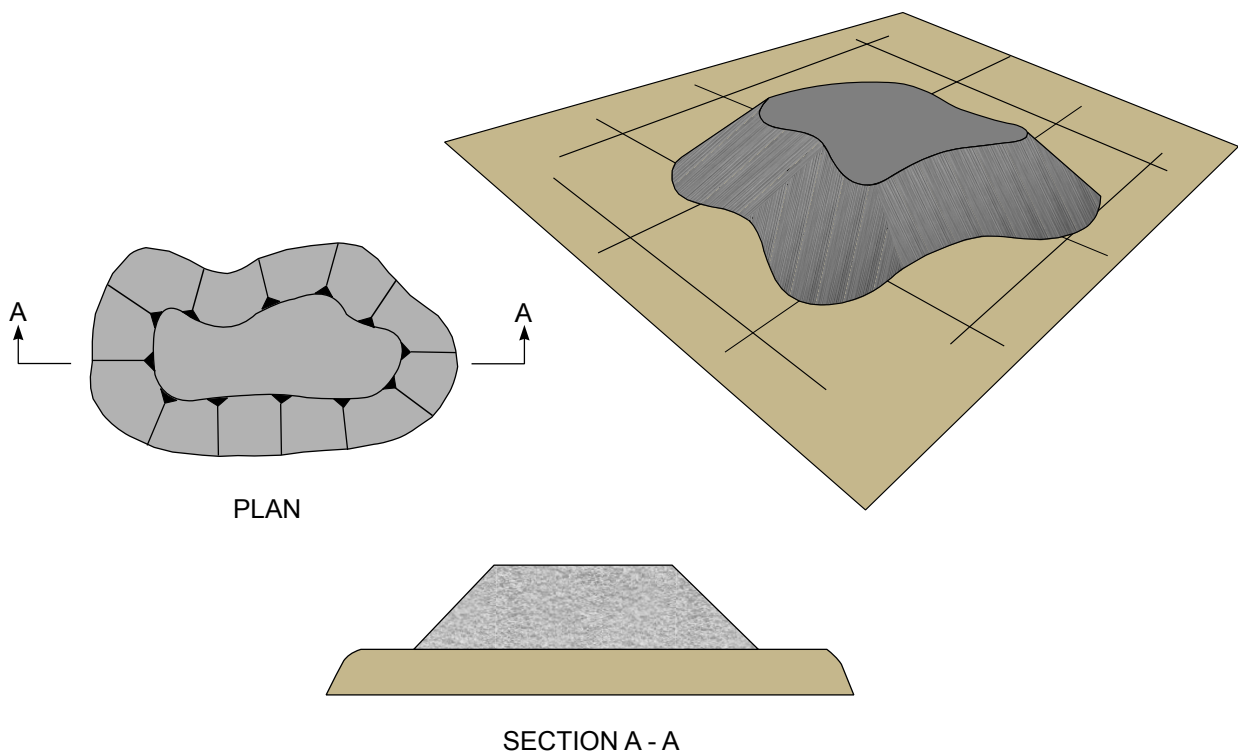

FIGURE 3.12 HEAPED (NON-IMPOUNDING) EMBANKMENT

relatively large ratio of coarse refuse to fine refuse, and (3) more detailed planning and supervision of the site so that the construction, filling, and covering of cells is accomplished in the proper sequence. Also, a slurry cell facility can potentially be reclassified as having high hazard potential, increasing the diversion and cell spillway requirements and impacting the long-term feasibility of the concept.

While one of the attractions of the slurry cell concept is disposal of fine refuse slurry in a structure with low-hazard-potential classification and thus less stringent design storm requirements, it may be advantageous to employ the concept at an impoundment site to mitigate potential impacts from underground mining and breakthrough potential. In such a case, the embankment design would be in accordance with the appropriate impoundment criteria, and additional operating plans would be required for disposal of slurry within cells constructed in the impoundment area.

3.4.2 Disposal Facility Configuration and Development

Non-impounding facility configurations established by MSHA may be developed using the slurry cell concept, although the quantity of available coarse refuse typically requires a valley-fill or side-hill configuration. The valley-fill configuration is generally developed in the upstream direction after a sufficient embankment height and top surface is reached to enable individual cells to be constructed. Consequently, beginning a slurry cell system may require operation of another disposal facility (e.g., underground injection), an existing disposal facility (e.g., old impoundment), or available fill material (e.g., mine spoil from other site development work) in order to achieve a sufficient working surface and embankment configuration to initiate slurry cell operation. As the disposal embankment is raised in height and additional cells are constructed over covered cells, hazard classification may become an issue. Therefore, the use of a valley fill for a slurry cell facility will likely have limitations. [Figure 3.13](#) shows a slurry cell facility developed in a valley-fill configuration.

Use of slurry cells with side-hill and heaped configurations is less common, unless backup disposal capacity is required in conjunction with the underground injection of fine coal refuse. These configurations require a larger quantity of coarse refuse for development of the structural shell, but this

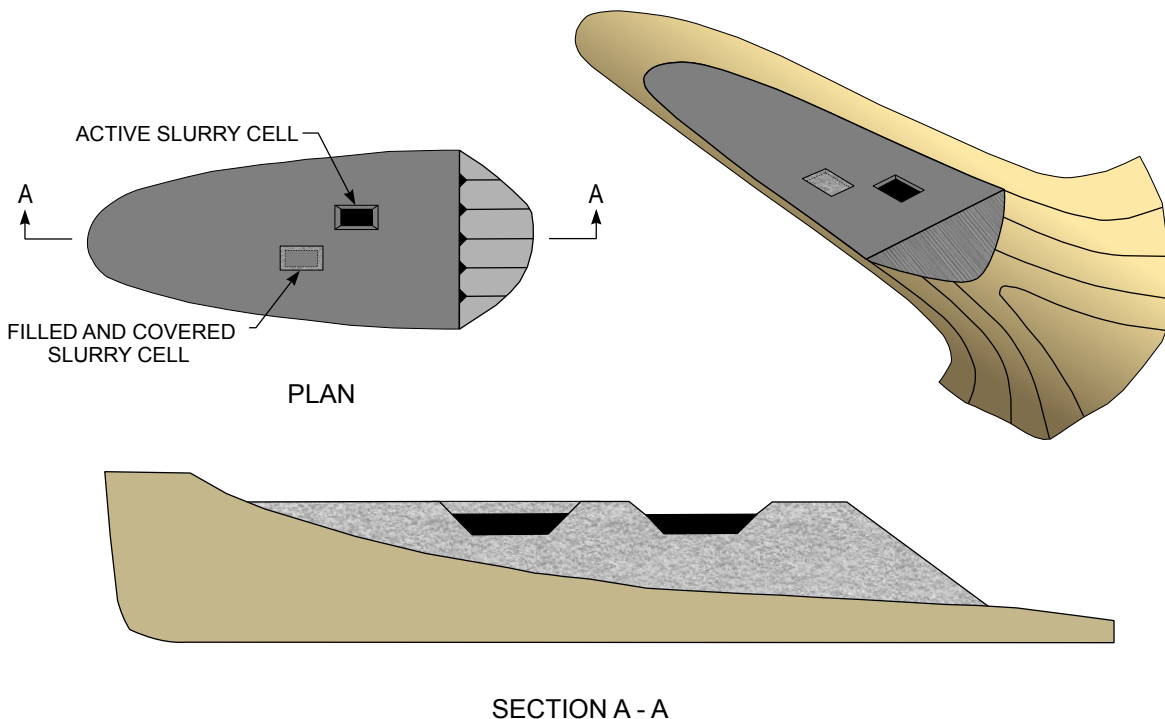

FIGURE 3.13 SLURRY CELL IN VALLEY FILL, NON-IMPOUNDING EMBANKMENT

material may not be available considering the need for coarse refuse to construct individual small cells. Figure 3.14 illustrates a slurry cell facility developed with a side-hill configuration.

Slurry cells may also be incorporated into an impoundment configuration, if issues of underground mining and breakthrough potential cause concern over the quantity of flowable impounded material. Figure 3.15 illustrates a slurry cell facility developed at an impounding embankment.

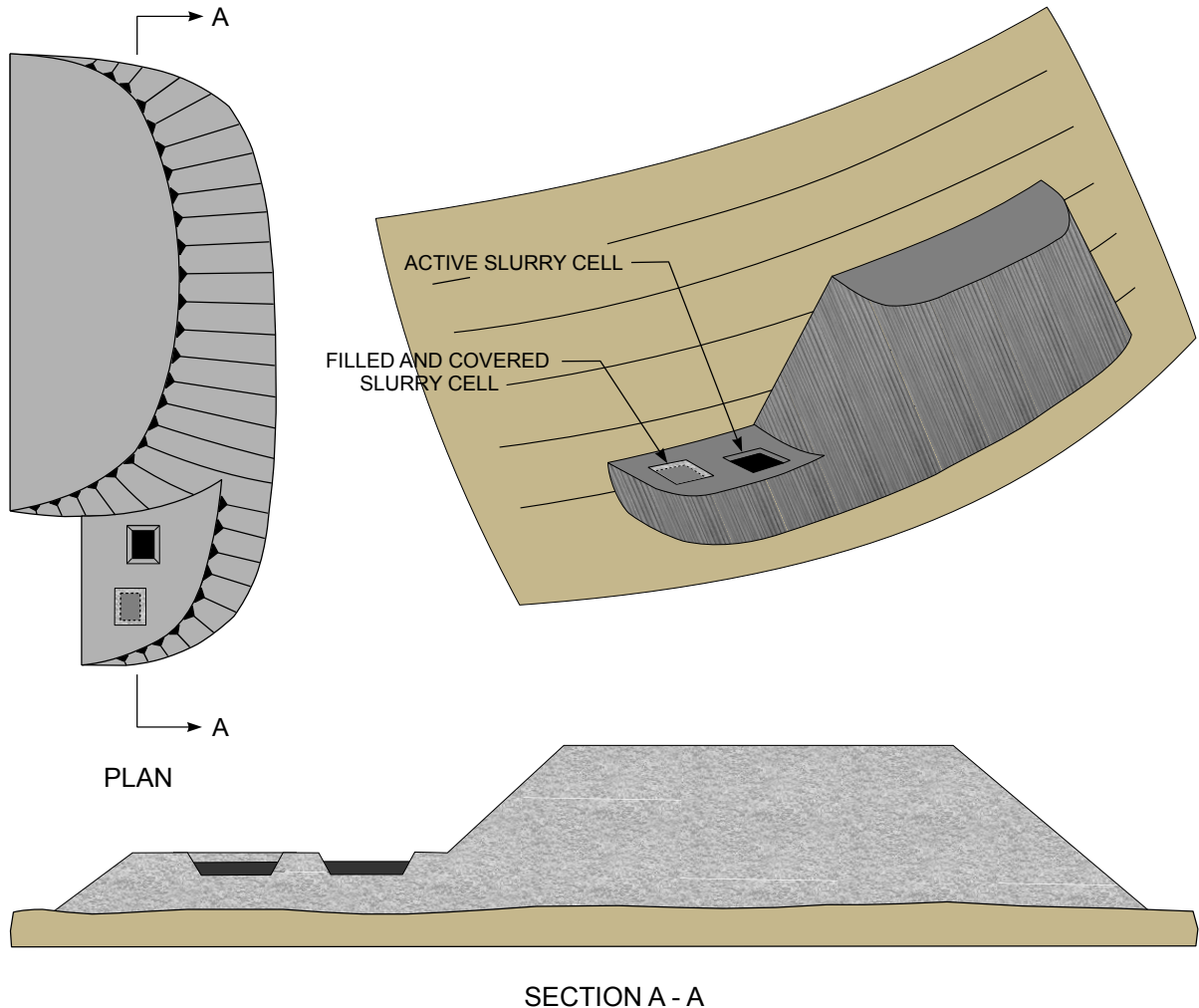

FIGURE 3.14 SLURRY-CELL, SIDE-HILL, NON-IMPOUNDING EMBANKMENT

3.5 UNDERGROUND INJECTION SITES

Fine coal refuse slurry can be disposed within underground mines by injection. Background information for the technical feasibility of underground disposal can be found in a publication by the National Academy of Sciences (NAS, 1975). There are state and federal regulatory programs for these operations, and the Virginia Department of Mines, Minerals and Energy, Division of Mined Land Reclamation has developed guidance for planning, design, operation and monitoring (VA DMLR, 2006). Planning and design for underground slurry disposal is discussed in the following subsections.

3.5.1 Siting

Background information useful for planning and design includes property ownership, geologic strata, hydrogeologic conditions, and data describing the mine workings to be used for disposal, including mapping, extraction information, mine dewatering and discharge conditions, proximity to active mine areas

and associated barrier information (coal barrier and bulkheads). The capacity of the underground workings should be determined, and the potential duration for slurry disposal should be estimated based upon settling and the ultimate solids content of deposits. Consideration should be given to the following:

- Lineaments, faults, and fractures as possible conduits of slurry.
- Recharge and discharge of groundwater into the mine workings as an indication of the hydraulic connection of the mine works with the fracture flow system.
- Surface openings that could or will become a discharge point, and coal barrier requirements and stability, with an assessment of the amount of weathering of out-crop, jointing, and previous or planned surface or auger mining.
- Presence of groundwater users, radius of influence of withdrawal wells, and connectivity with mine voids.
- Mine works overlying and underlying the mine work receiving injected slurry, including inventory and assessment of vertical dewatering holes, subsidence fracturing, and associated surface openings.
- Proximity of and impacts on active mines.
- Slurry injection and movement through mine workings, including water balance analysis of injection flows and surface and groundwater conditions.
- Leaching of contaminants from emplaced slurry, including potential impacts from process chemicals, and sorption characteristics of processing chemicals on coal and sand/clay particles.
- Hydrologic conditions that could develop after cessation of injection, including development of equilibrium groundwater conditions.
- Potential impacts to near-surface groundwater resources

3.5.2 Injection System Design

The following issues related to injection system design should be addressed:

- Drilling methods for penetrating the abandoned mine to reduce the potential of creating an ignition source.
- Design of bulkheads and seals that may be required to control the deposition of slurry or direct drainage toward acceptable discharge locations.
- Injection site and slurry line/alignment, including construction and service access, drainage control, and secondary containment.
- Injection well design including maximum pressure (below level for hydraulic fracturing of overburden or mine barriers, and system components such as casing), complete casing of overburden (with double casing provisions when penetrating upper mine voids), casing grouting methods through overburden, and wellhead completion with air gap to prevent pressurization of the well, if applicable, or pressure control and monitoring. Where pressure injection is required, a control system to limit pressures to the maximum design value must be employed, along with backflow prevention in the event of slurry line rupture.
- Secondary containment for piping and injection site, including monitoring and controls that shut down the slurry pumps in the event of piping failure.
- Operating procedures and flow rates, including hours of slurry disposal/process water pumping, and measures to prevent the introduction of oxygen into the mine.

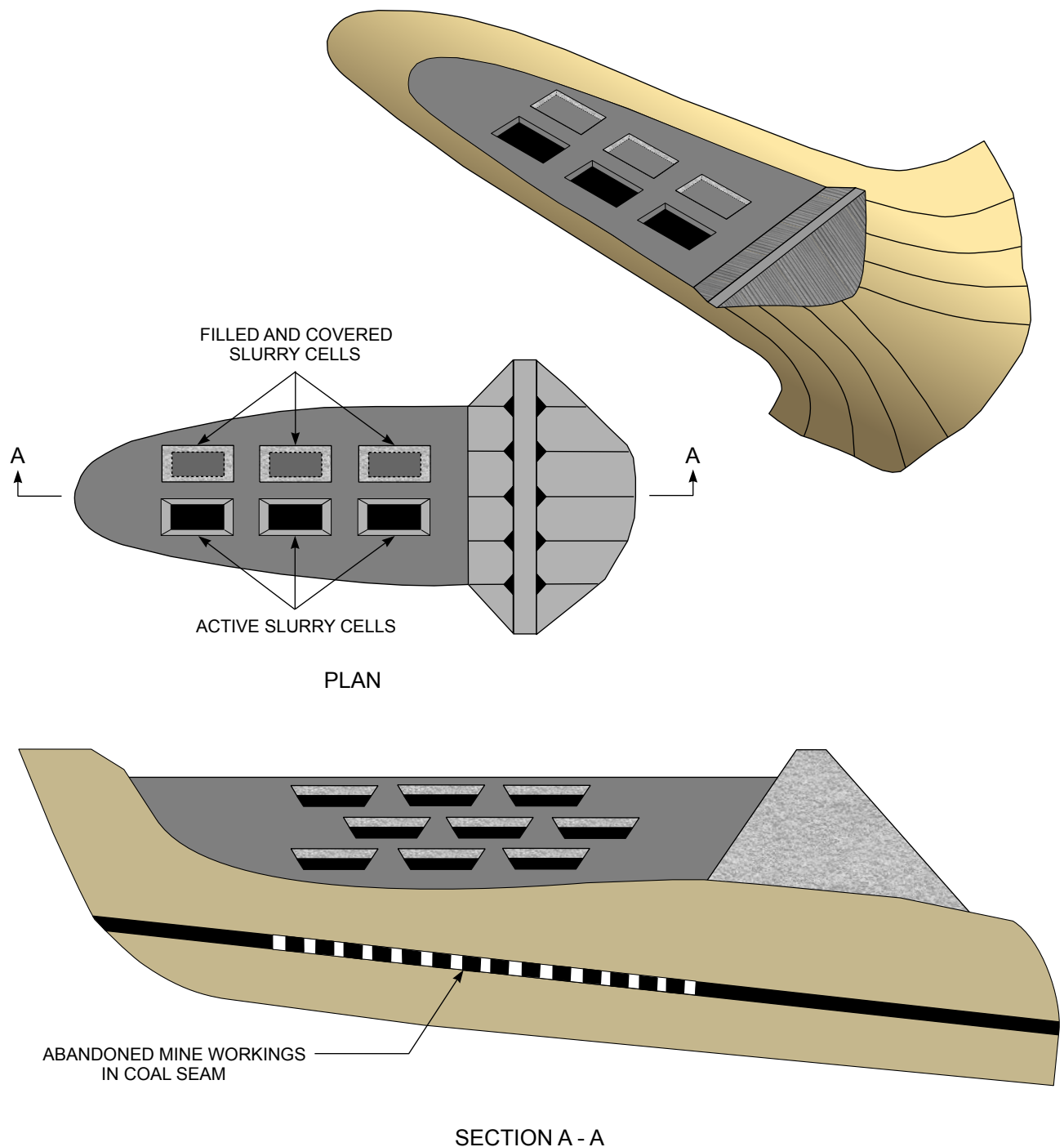

FIGURE 3.15 SLURRY CELLS IN CROSS-VALLEY-FILL, IMPOUNDING EMBANKMENT

3.5.3 Risk Assessment and Response Plan

The following are issues that should be considered in the evaluation of risks associated with release and potential response actions:

- Avenues of release (both surface and underground) and human exposure pathways. A concern is ingestion through drinking water wells with capture zones that may draw water from underground mine works or be connected to mine works through fracture systems.

- Blowout potential associated with the injection pressures, slurry and water accumulation, and barrier stability. The barrier stability evaluation should reflect subsequent surface, auger, or highwall mining that may have thinned or penetrated the barriers. Future restrictions on mining in barriers should be considered if such potential exists.
- Environmental receptor identification relative to groundwater and surface water, considering contamination potential due to acid forming materials and petroleum solvents or other chemicals used in the coal preparation plant and solids deposition within streams.
- Response to release, including: (1) steps to determine the extent of release, (2) identification of emergency containment and cleanup resources (in-house and contracted) and associated steps to initiate action, (3) disposal of wastes generated during cleanup, and (4) implementation of operational contingency plan for ongoing slurry disposal.

3.5.4 Contingency Plan

Contingency disposal options should be established for fine coal refuse slurry if injection is suspended for emergency or performance reasons. The plan should include steps to be taken to shut down the current injection operation; facilities and designs for interim slurry disposal such as alternate injection locations (in the event of performance based shutdown) or emergency ponds and drying cells, dewatering equipment, etc.; and longer-term options for disposal such as slurry disposal cells.

3.5.5 Monitoring Plan

Monitoring for slurry injection, emplacement, mine water levels and mine discharge rates/quality for the injection target and adjacent mines, as applicable, should be developed, along with groundwater and surface water monitoring. The parameters, methods, and frequency for monitoring should be established based on site conditions, sound engineering judgment, and applicable regulatory programs.

- Slurry injection monitoring for organic and inorganic parameters should be performed to assess potential groundwater and surface water impacts, as required by regulatory programs.
- Slurry emplacement monitoring should include monitoring wells and discharge points within the mine works for detecting the presence of slurry solids for comparison with predicted slurry and water accumulation and movement, and planning subsequent injection sites.
- Mine pool/discharge water monitoring should be performed and the data should be compared to the maximum predicted mine pool level and discharge rates, and water balance analysis.
- Groundwater monitoring should include wells located in hydrogeologic units most likely to be influenced by the injection operation, such as the fracture flow system, the subsidence fracture zone overlying workings, and the coal seam adjacent to mine workings impounding the slurry. Lineaments should also be considered when selecting locations to be monitored. Potable wells within the expected zone of influence of the injection operation should be monitored, but these wells should not be considered as groundwater monitoring unless well construction details are known.

With the use of an underground injection site for slurry, the coal preparation plant will also require a surface disposal facility for coarse coal refuse. As indicated above, contingency disposal options should

be developed if underground injection proves to be infeasible. Such options could include use of slurry cells or conversion to combined refuse if the preparation plant is equipped for fine refuse dewatering.

3.6 RECOVERY (REMINING) OF COAL REFUSE DISPOSAL FACILITIES

Recovery (sometimes referred to as re-mining) of coal refuse from existing active or previously abandoned embankments and impoundments is performed at some sites and involves the use of advanced processing methods to obtain additional coal for fuel or power generation. In such situations, a ground control plan addressing safety issues associated with re-mining operations should be submitted to MSHA. The re-mining process involves the excavation and removal of coal refuse and, where processing is performed on site, disposal of waste from the coal processing plant. Thus, a modification of the existing site refuse disposal plan will generally be necessary.

Recovery or re-mining may involve exploration, excavation and handling, final grading, and reclamation on soft or loose materials including operation in wet, saturated or submerged conditions. Exploration will typically include initial as well as periodic operational borings and test pits for evaluation of geotechnical and groundwater conditions as well as marketability of the excavated coal refuse. Low-ground-pressure equipment, upstream pushout of a coarse refuse pad, or barge operation may be needed depending on impoundment conditions, and procedures and safety precautions appropriate to the method used should be developed.

Under relatively dry conditions, dozers, excavators, end-loaders, scrapers, or a clamshell can be used for excavation of refuse and fines from an impoundment. Procedures and safety precautions that are suitable for the conditions encountered should be developed, and when soft or loose fine refuse is present, stability analyses to determine if the excavation slopes will be stable should be conducted. For impoundments built by the upstream construction method, a buffer zone or distance should be maintained between the area of excavation and the upstream slope of the impounding embankment or other fill that may be present.

Surface runoff should be diverted around the operation area to the extent possible, and the active work area should be graded so that water drains toward ditches and sumps. Lowering the phreatic level in the fine coal refuse to the extent possible by surface runoff control and removal of groundwater will improve ground conditions for equipment operation, allowing maximum recovery of coal. Consideration should be given to grading, deep sumps, and other dewatering measures for lowering the phreatic level, and the phreatic levels should be continually monitored during operation. At sites where control and removal of surface and groundwater is not practical at all times of the year, safe and economic removal of fines may only be possible during dry periods. In such instances, evaluation of the degree and depth of saturation of the fines should be made prior to resumption of operations.

When wet and submerged conditions are present, dredges and hydraulic sluicing (water cannons) are sometimes employed to remove fines from an impoundment. Accidents have occurred when steepened slopes of fines have collapsed, sending a wave of material across the impoundment. Besides the operating concerns discussed above, additional safety concerns must be addressed, and it is important to establish guidance for equipment operation. Land anchors used to position dredges should be located on solid ground and kept well back from areas that might be susceptible to slope failure as the dredging progresses. The safe distance that any operator or equipment not on solid natural ground (including anchor equipment) approaches the working face should be evaluated and should generally be limited to no closer than twice the vertical height of the working face. When dikes built across the impoundment to divide it into sections are present, personnel and equipment should not be allowed on dikes adjacent to active dredging operations until dredging has ceased and the stability of the area has been assessed. Personnel and operating equipment must have the proper safety equipment for working at a dredging operation.

Upon completion of the recovery operation, final grading and reclamation should provide long-term stability of slopes and drainage channels. This work is typically performed with conventional earth-moving equipment, and many of the operating procedures and safety precautions for this phase of recovery are similar to typical reclamation requirements.

For embankments or impoundments that are to be remined, engineering plans addressing the following should be prepared for review and approval:

- Excavation of coal refuse, including the method of removal, temporary slopes, sequence, and resulting configuration of the facility, with associated provisions for controlling drainage and maintaining stability during operations and following completion.
- Slope stability analyses (for both permanent and temporary slopes) demonstrating acceptable factors of safety where miners are subject to potential slope failure hazards. The slope stability analyses should include consideration of rapid drawdown conditions associated with the removal of fine refuse. If excavated slopes that are intended to be temporary and are designed for short-term conditions remain in place much longer than planned (or become permanent because of the idling of recovery operations), they should be re-designed with long-term factors of safety.
- Changes in seepage resulting from pooling of water as fine coal refuse is removed.
- Operating procedures and precautions specific to the excavation and recovery methods used (e.g., conventional construction equipment, barge and dredge equipment, water cannon operation) to provide for safe access and mining.
- Monitoring of compliance with the excavation plan and inspection of slopes and drainage control structures.
- Disposal plans for waste from the reprocessing of the coal refuse.
- Reclamation and abandonment of the disposal facility.

If fine coal refuse is to be removed from a slurry impoundment, the potential impacts on the safety of the impoundment should be addressed in the plans. This should include potential impacts on the outlet structures and facility operation during the design storm and limitations on the extent and slope of the excavation so that other parts of the facility are not compromised. For instance, if there is upstream construction or barriers related to mine workings are built over slurry, removal of fines could remove support for the embankment crest or barrier structure. In such cases, an analysis for determining the necessary buffer and excavation slope such that fines recovery can take place without compromising the stability of the embankment or barrier structure is required.

3.7 OTHER IMPOUNDING STRUCTURES

In addition to coal refuse disposal facilities, mine sites may have other impounding structures such as fresh-water reservoirs to provide make-up water for the processing of coal and sedimentation and treatment ponds to handle runoff and drainage from refuse embankments, surface mined areas and other disturbed surfaces. In some limited surface mining situations primarily in the western U.S., dams may be used for flood control during the temporary period when the mine pit advances near a water course. These structures are generally traditional dams and reservoirs that, while having many of the same features as a slurry impoundment, may also have additional features associated with influent and effluent controls. Additionally, these impoundments are generally constructed during a limited time period that may or may not be related to mining or coal processing rates.

Fresh water impoundments are typically located close to the coal preparation plant and are sized and located within a watershed to provide an adequate quantity of process water. These structures are

typically dams, generally built of soil and rock fill, with primary and emergency spillways and piping tied into the preparation plant. They are differentiated from slurry impoundments by their design to maximize water storage and the presence of gated spillways and distribution pipelines. Additionally, they may have a significant depth of water and thus be subject to greater hydraulic head than would be expected for a slurry impoundment.

Sedimentation ponds are required as part of erosion and sediment control measures for runoff from disturbed mining areas, including coal refuse disposal facilities. These ponds are smaller structures than slurry impoundments and fresh water reservoirs, and they are sized to meet state regulatory criteria based on the contributing disturbed area and other hydrologic factors. They are frequently designed so as not to be classified as an impoundment regulated by MSHA. They typically have primary and emergency spillways.

Treatment ponds are similar to sedimentation ponds and are used to treat drainage from disturbed mining areas, including drainage from coal refuse disposal facilities and water pumped from underground mine workings to meet suspended solids and water quality effluent requirements. In many cases, chemicals are added to these ponds to neutralize acidic conditions and to precipitate metals such as iron and manganese. Because they are used for treatment of drainage to improve water quality, the associated drainage area is limited and the surface runoff entering the ponds is minimal. These ponds are generally small structures, frequently below the MSHA size classification for impoundments. They typically have primary and emergency spillways, and gated controls are often part of the primary spillway.

Flood-control dams are sometimes constructed in a water course to prevent or mitigate flooding of a surface mine pit. The water course may have significant flow, particularly during thunderstorms or periods of snowmelt. These dams may be small or large temporary structures, generally located in the western U.S., and are required only during the period when the mine pit could be affected by flooding from the water course. In situations where there is no threat to the public off of mine property, it may be possible to design the dam using low- or significant-hazard-potential hydrologic criteria, provided that a warning system and plan is developed and maintained for notifying and evacuating personnel involved with the mining operation when the water behind the dam reaches a specified level. [Table 3.1](#) presents guidance that should be considered or evaluated as part of the MSHA impoundment plan if a warning system is being used to support the selection of low- or significant-hazard-potential hydrologic criteria for a flood-control dam at a surface mine pit.

The geotechnical and hydrology/hydraulic engineering requirements for fresh water impoundments, flood control dams, sedimentation ponds, and treatment ponds are substantially the same as for slurry impoundments, and design criteria are typically identical. Aspects of engineering analyses and design that may be different for fresh water impoundments than for slurry impoundments are addressed in other chapters of this Manual.

3.8 SMALL PONDS AND SIMILAR STRUCTURES

Some structures that are capable of impounding water or temporarily storing slurry on mine sites may not exceed the threshold size that would require an approved MSHA plan, but they should be designed in a manner consistent with the engineering guidance provided herein. Many sedimentation ponds and emergency slurry holding ponds at preparation plants are deliberately sized below impoundment threshold criteria and generally do not have significant hazard potential. These structures are typically regulated by states as ponds or small dams and are designed in accordance with applicable state criteria.

TABLE 3.1 GUIDANCE FOR FLOOD WARNING SYSTEMS AT SURFACE MINE PITS⁽¹⁾

1. A warning system should typically consist of power supply equipment (primary and emergency back up), water level monitors, and automated communications equipment. The entire system should be designed by a qualified engineer.
2. The evacuation warning level should be established based upon the potential time required for evacuation of the surface mine pit and the potential rate of inflow. Ideally, the warning should be triggered at a level that allows for evacuation before overtopping of the dam by the PMF and resulting inundation within the pit to a critical level. The flood control structure should typically be maintained either in a dry condition or with a limited water level and storage volume that would not present a hazard to downstream personnel. When determining the water level for the warning system, any water stored behind the dam must be taken into account.
3. Multiple warning levels should be considered. For example, in addition to the evacuation warning level, an alert should also be issued at a lower level that would result in mine personnel coming to the dam to verify that the system is working correctly and to monitor the situation.
4. While the mining operation is immediately downstream of the dam, the warning system should be tested on a frequent basis and, if practicable, before expected large meteorologic events.
5. The warning plan should clearly define the procedures to be followed when the warning system is activated, and mine personnel should be trained on the appropriate response to a warning.
6. The warning plan should address the status of the dam after the mine pit has advanced beyond the influence of the water course. The plan should state whether the dam will be removed or will remain in place. If the dam is to remain in place, it should be evaluated, as necessary, to verify that the hazard potential classification is appropriate for the downstream area potentially affected by a dam failure. The warning system approach should only be in effect for the potential hazard posed to the mining operation for the temporary period when the pit could be affected.

Note: 1. Use of a warning system must not be a substitute for appropriate dam design and construction. MSHA has indicated that a warning system may be acceptable on a case-by-case basis for support of the use of low- or significant-hazard-potential design criteria at flood-control structures to prevent or mitigate flooding of a surface mine pit. The guidance presented herein reflects conditions that should be considered or evaluated as part of an MSHA impoundment plan.

(FREDLAND, 2008)

Chapter 4

PROJECT PLANNING

Planning for a coal refuse disposal facility should be integrated with overall mine development and operation plans. Procedures for the planning and design of safe, environmentally acceptable and economical refuse disposal facilities are stressed throughout this and subsequent chapters of this Manual. This chapter presents important planning and design sequences and procedures that can be employed to optimize refuse disposal operations. Topics covered include:

- Unique aspects of refuse disposal
- Operations and site-related considerations
- Sustainable mining practices
- Economic considerations
- Environmental and regulatory considerations
- Planning sequence
- Design sequence

Understanding these topics is essential to the design and construction of a refuse disposal facility that imposes minimal restraints on the production of coal, assures the safety of miners and the surrounding public, and protects the environment. A refuse facility that meets these goals ultimately optimizes control of the overall cost of mining operation.

4.1 UNIQUE ASPECTS OF REFUSE DISPOSAL

The disposal of coal refuse materials from preparation to transport and placement imposes problems that are similar in many ways to more routine types of civil or mining construction projects. However, some aspects of refuse disposal may provide opportunities for optimization as follows:

- Dissimilar refuse materials are continually generated. These include: (1) coarse refuse in solid form, (2) fine refuse in slurry or dewatered sludge form, and (3) for some sites, combined coarse and fine refuse. The characteristics and quantities of coal refuse may change over time due to changes in geology, production, mining methods, and coal preparation. Anticipating these changes in advance provides an opportunity to develop a cost-effective disposal plan.

- Refuse materials can be disposed in a manner that allows for post-mining land use that can enhance the future value of the property.
- Coarse refuse, at times supplemented with amounts of borrowed soil and rock materials, may be used to develop the structural capability to retain less carefully placed or slurried refuse. In some instances, amendments such as industrial by-products containing lime to address acid generation within the refuse are necessary and these amendments can make up a significant percentage of the material placed.
- Co-disposal of coal combustion waste (fly ash and bottom ash) with coal refuse may be an effective contracting strategy or necessity for the mine, and this waste can be used as an amendment to benefit the refuse disposal facility. Combustion waste can be a significant percentage of the material placed and, like amendments, can alter embankment material properties.
- A disposal facility may be adapted to serve other operating requirements, such as the recovery of clarified water for return to the preparation plant.
- Short- or long-term water impoundments may be created behind properly constructed refuse embankments.
- Some structural or hydraulic features must be adaptable to modification as the facility grows in size and shape over its service life.
- Transport methods and equipment may change as the facility grows horizontally and vertically.
- Technological advancements, market demands and regulation changes may occur within the service life of the facility.
- Final portions of coarse refuse from normal operations, rather than borrow material, may be used to make the completed facility structurally safe and environmentally acceptable for abandonment.
- Portions of refuse, properly mixed with appropriate amendments, may be used to facilitate planting on a completed portion of the facility when reclamation soils are scarce.

A major factor in many of the above items is the abundance of refuse material available for construction, at little or no added cost. Proper planning must be employed to take advantage of the favorable characteristics of refuse and to minimize the need for using more costly borrow soil and rock and specially purchased construction materials.

4.2 OPERATIONS AND SITE-RELATED FACTORS

Each mine has characteristics that uniquely affect overall coal production and processing operations. Proper planning on a site-by-site basis will assure that processing and refuse disposal procedures that best suit the mining operation are established. It is possible, however, to develop a list of considerations for the planning of practically all refuse disposal facilities, corresponding to elements of federal and state permitting requirements. The length of this list and its subject breadth illustrates the importance of meaningful coordination between management, operating personnel and the design/permitting team. These factors can be grouped into two categories, as follows:

Factors Primarily Related to Disposal

- Capacity, number and location of potential disposal areas at the site.
- General topographical, soils, geologic, seismological, hydrologic and cultural char-

acteristics of the site. Cultural characteristics may include buildings, infrastructure (such as roadways, pipelines, power lines, etc.), and cemeteries.

- Environmental and ecological conditions at the site, including surface water, ground-water, wetlands, wildlife and plant species.
- Mining (past, current, or potential future), oil and gas development, and other natural resources at the site. Analyzing the potential impacts from active or abandoned underground mines that may underlie a refuse site is of utmost importance. Previous site development and refuse disposal activities should be identified.
- Capital requirements for initiating disposal at each disposal area.
- Operating and maintenance costs at each disposal area.
- The relationship between the capacity of each disposal area and its distance from the preparation plant.
- Proximity of population centers and residences.
- Current property boundaries and land availability.
- Land-use practices within and in adjacent areas and post-mining land-use considerations.
- Contingencies for unexpected conditions (i.e., changes in mine life resulting in changes to the final embankment configuration and abandonment provisions).

Factors Primarily Related to Overall Operations

- Public relations.
- Source of coal and type of mining.
- Extent of preparation of coarse and fine refuse.
- Production rates of coarse and fine refuse and their reliability.
- Changes in geologic conditions as the mine advances.
- Anticipated life of the mine.
- Geochemical characteristics of coarse and fine refuse.
- Water requirements for the preparation process.
- Modifications needed to meet future market demands and regulation requirements.
- Available and preferred materials handling equipment.
- Flexibility in location of preparation plant.
- Required infrastructure (roads, portals, slopes, shafts, conveyor beltlines, railroads, etc.) during the life of the mine.
- Additional materials generated at the mine by other operations or by nearby construction projects (site developments, power plants, etc.) that might provide economic value and be beneficial when combined with the disposed refuse.
- Water treatment facilities required for operation or environmental control.
- Corporate policy on capital expenditures versus operating costs.

Data relative to each of the above factors can be obtained through preliminary investigations and discussions with appropriate mine personnel. This information can then be used to formulate specific studies leading to refinement of the project plan, performance of site-selection studies, and initial design. As discussed in [Sections 4.6](#) and [4.7](#), the designer must coordinate closely with the operating staff during the early project stages and must incorporate environmental, permitting and regulatory requirements into the facility planning.

4.3 SUSTAINABLE MINING PRACTICES

Sustainable mining practices have evolved into management of natural resource development in a manner compatible with the environment and the needs of the community in which mining plays a significant role. By practicing sustainable development, mining companies can improve their access to land and markets, as well as enhance their reputations and value, and thus promote the coal industry. Yearly (2003) cites the following three tenets for sustainable mining:

- Integrated approaches to decision making on a full, life-cycle basis that satisfy obligations to shareholders and that are balanced and supported by sound science and social, environmental and economic analysis within a framework of good governance.
- Consideration of the needs of current and future generations.
- Establishment of meaningful relationships with key constituencies based on mutual trust and a desire for mutually beneficial outcomes, including those inevitable situations that require informed trade-offs.

Inherent in sustainable development is: (1) the commitment to implement effective planning and design practices and (2) the need for research and development leading to improved methods for harnessing natural resources with minimal impacts on the environment. Government regulation creates the framework for protecting the environment from impacts, although it is the mining professionals who are responsible for establishing the plans and designs that accomplish the mining operations in a sustainable manner. This may require the involvement of a diverse professional community. Sustainable mining goals established for engineers and leaders in the mining industry and detailed in the Milos Statement from the International Conference on Sustainable Development Indicators in the Mineral Industries held in Milos, Greece are discussed in Karmis (2003).

Project planning for coal refuse disposal should be integrated with overall development and operations planning for mining activities. In the following paragraphs, economic, environmental and regulatory considerations are addressed, along with planning and design sequence.

4.4 ECONOMIC CONSIDERATIONS

To achieve the desired optimum solution, economic factors must be considered during all phases of disposal facility planning, design and implementation. Major economic decisions are required for: (1) selecting the disposal facility site, (2) selecting the materials handling systems, and (3) for planning the entire sequence of disposal operations from initiation through abandonment. The expenditures required are usually classified as:

- Capital costs
- Operation and maintenance costs
- Reclamation (abandonment) costs
- Potential long-term liability costs

The determination of these costs is part of the planning process and influences the design, permitting and site operations. Periodic updates of estimated costs should be part of the planning and design process. Disposal facility planning and design should be keyed to the financial requirements of the mine, so that cash projections cover the costs associated with operating and maintaining the disposal facility. Carefully planned investment during initial phases of site development and selection of disposal facility configurations can have a major beneficial effect on subsequent operating and reclamation (abandonment) costs.

Table 4.1 presents a general breakdown of various cost components associated with planning, design, and implementation of a coal refuse disposal facility. These components are provided as a general

guideline for developing costs. Specific site conditions and operational requirements may introduce other elements not reflected in the table.

TABLE 4.1 COAL REFUSE DISPOSAL FACILITY COST COMPONENTS

I. Capital Cost	
Property Acquisition	
Permitting and Planning	
Engineering and Design	
Site Development	
Access Roads	<ul style="list-style-type: none"> Erosion and Sedimentation Control
<ul style="list-style-type: none"> Wetlands and Stream Mitigation Site Preparation Perimeter and Diversion Ditches Liner and Underdrain System Decant Installation Mine/Entry Stabilization or Protection Refuse Transport and Handling System 	<ul style="list-style-type: none"> Amendment Transport and Handling System Starter Embankment Internal Drainage System Decant Installation Spillway Construction
II. Operating Cost	
Equipment Operations	
<ul style="list-style-type: none"> Refuse Transport (haulage & pumping systems) Refuse Placement and Compaction 	
Facility Construction	
<ul style="list-style-type: none"> Site Preparation for Facility Expansion Perimeter and Diversion Ditch Extension Mine/Entry Stabilization or Protection Liner and Underdrain System Extension Amendment Materials 	<ul style="list-style-type: none"> Haul/Access Roads and Surfacing Internal Drains Installed in Stages Decant Pipe Extension and Capping Spillway Extension Survey Control
Maintenance	
<ul style="list-style-type: none"> Erosion and Sediment Control Haul/Access Roads and Surfacing Liner and Ditch Repairs 	
Regulatory Compliance and Reporting	
<ul style="list-style-type: none"> Site Inspections and Testing Monthly, Quarterly, and Annual Reporting 	
III. Reclamation Costs	
Engineering/Permitting Oversight	
Facility Construction	
<ul style="list-style-type: none"> Impoundment Backfilling and Stabilization Site Grading Cap/Soil and Topsoil Placement Revegetation 	
IV. Potential Long-Term Liability Costs	
Acid Mine Drainage Treatment	
Mine Discharge	
Erosion and Sedimentation Control	
Revegetation	

4.5 ENVIRONMENTAL AND REGULATORY CONSIDERATIONS

Environmental and regulatory considerations should be incorporated into the planning process, and can be defined steps performed as part of, or in advance of, the permitting of the coal refuse disposal facility with state and federal agencies. These considerations are addressed jointly, because frequently the method for addressing environmental issues may be directed by regulatory guidance or law. Primary federal statutes and regulations include the Federal Mine Safety and Health Act (1977) and the Surface Mining and Reclamation Act of 1977 (SMCRA), as well as more widely applicable statutes and regulations such as the Clean Air Act and Clean Water Act. SMCRA established the Office of Surface Mining (OSM) with authority to implement a national program to regulate surface effects resulting from coal mining. State regulatory programs and agencies may take on this responsibility, if approved by the OSM, which will remain in an oversight role. For the states that take on this responsibility, most of the regulatory requirements of their programs are similar to the OSM regulations found in 30 CFR Chapter VII. In response to local concerns and conditions, some state programs have requirements that are more extensive than the federal rules. Additionally, some state agencies responsible for other programs, such as dam safety, impose requirements for coal refuse disposal facilities. Designers should contact state regulatory agencies to obtain current information on their regulatory programs and requirements.

Environmental issues at some sites can require significant time and effort to address, affecting the entire regulatory approval process. This section discusses environmental and regulatory considerations in the planning process, and the engineering and design of specific containment structures at disposal facility sites are discussed in subsequent chapters of this Manual. However, the state and federal permitting process, including environmental impact studies and mitigation requirements, is left for other publications. Because state regulatory input shapes many of the decisions associated with planning and design of a refuse disposal facility, contact with these agencies and review of their publications is essential.

Some specific environmental and regulatory factors that influence the planning and design of coal refuse disposal facilities include the following:

- Site selection process and permitting submittals prior to facility design. Some states require a rigorous process for site selection as part of permitting new coal refuse disposal facilities or the expansion of existing facilities.
- Facility configuration (slopes, benches, crest width, etc.). Federal and state regulations include specific requirements for some facility parameters, either as part of mining, coal refuse disposal, or dam permitting guidance.
- Erosion and sedimentation and stormwater control structures. State regulations and some local (municipal) entities provide specific guidance for meeting erosion and sedimentation control and stormwater requirements.
- Liners for containment of refuse materials. Some state regulations provide guidance for liners for refuse disposal facilities.
- Amendments for neutralization of refuse materials. State regulations provide guidance for acid neutralization of refuse materials.
- Wetlands and stream encroachments. Federal and state regulations provide guidance for addressing wetlands and stream encroachments, including mitigation requirements where necessary.
- Prime farmlands. State regulations provide guidance for addressing the presence of prime farmlands near proposed refuse facilities and include mitigation measures where necessary.

4.6 PLANNING SEQUENCE

Table 4.2 shows a typical sequence of events involved in the planning, design, operation and abandonment of coal refuse disposal facilities. Site-specific factors and the specific objectives of persons collectively involved in the process may preclude direct application of the indicated sequence. However, proceeding generally in the manner shown should aid in the design, permitting and construction of a coal refuse disposal facility. Particular notation is made of the following items:

- Continuing interaction between operations/mine personnel and the designer is shown. The important relationship between coal production and refuse disposal dictates this cooperation, if mine operation and facility construction are to proceed optimally.
- Interaction between the designers and the regulatory agencies relative to site selection and design elements is shown. This interaction will allow identification of special regional or site-specific concerns, methods to address concerns, and will generally facilitate the permitting process.
- Engineering should be an integral part of disposal operations, as well as construction monitoring and inspections, particularly on complex, long-term projects. Involvement of the designer, or engineering personnel thoroughly familiar with the design requirements, allows review of performance information relative to design parameters and identification of needed adjustments.
- The next to the last step (XI) in Table 4.2 is periodic review of mine operations and the disposal facility development. Regardless of the accuracy of initial planning, the typically long active period of use of a disposal facility makes it likely that unanticipated changes to the original design will occur. Periodic review of the effects of these changes must be performed so that continued safe, economical and environmentally acceptable refuse disposal can be achieved.

4.7 DESIGN SEQUENCE

The design sequence presented in Table 4.3 details the technical aspects of the total planning-implementation process for disposal facility development in a safe and environmentally acceptable manner. The primary design emphasis occurs during the third to seventh steps of the planning sequence in Table 4.2. The elements of coal refuse disposal facility design and their general interrelationship are presented in Chapter 5. Subsequent chapters of this Manual present detailed technical information and procedures related to completion of facility design.

Table 4.3 presents a typical sequence of design steps and provides a checklist of the most important items requiring consideration for a typical refuse disposal project. Reference is made in the table to sections of the Manual where additional detailed discussion is presented.

The items in Table 4.3 may not be totally applicable in all instances. In the case of small facilities, a very detailed study may not be appropriate, and portions of the investigation and analyses can possibly be eliminated by simply using conservative design assumptions. On the other hand, conditions may be present at other sites that require studies beyond those identified in Table 4.3. The existence of such special conditions can only be determined by an experienced designer through careful study of site conditions.

Item VIII in Table 4.3 summarizes the deliverable products of the design sequence, including the design report and preparation of facility plans and specifications. General guidance on the content of these documents is presented in Chapter 11; however, site-specific issues may require elements not identified in the table.

TABLE 4.2 PLANNING STEPS FOR COAL REFUSE DISPOSAL FACILITY DESIGN

	Planning Steps	Participants	Regulatory Involvement
I	Gather and Evaluate Mine Development and Disposal Information	Management Operations Engineering	No
II	Perform Initial Siting Studies, Develop Disposal Concepts and Conduct Alternatives Analyses for Potential Sites	Operations Engineering	Yes
III	Perform Detailed Investigations and Prepare Preliminary Design	Engineering	No
IV	Modify to Best Suit Operations and Evaluate Development Costs	Operations Engineering	No
V	Confirm Preliminary Design Assumptions and Regulatory Criteria	Management Operations Engineering	Yes
VI	Finalize Plans, Specifications and Permit Documents; Refine Development Costs	Engineering	No
VII	Final Approval	Management Operations Engineering	Yes
VIII	Implement Site Development	Operations Engineering	Yes
IX	Conduct Disposal Operations	Operations Engineering	No
X	Construction Monitoring, Maintenance	Operations Engineering	No
XI	Periodic Inspections and Review of Operations	Management Operations Engineering	Yes
XII	Abandonment and Reclamation	Operations Engineering	Yes

Preparation of a design report is suggested for all facilities, regardless of the required extent of investigation and analyses. This report: (1) provides the opportunity for all parties (designer, operator and regulatory groups) to understand design assumptions and limitations, (2) provides the opportunity for the designer to clearly state validating design assumptions during the construction or operations phases, and (3) helps to avoid confusion or misunderstanding between the designer, operator and regulatory groups.

Clear and accurate plans and specifications are essential for operations personnel to properly construct and develop a disposal facility and for the operator's quality control representatives to verify that all details are completed correctly. Accurate plans and specifications minimize the potential for misunderstandings that could cause schedule delays during the review period and during construction. General guidance for the content of refuse facility plans and specifications is presented in Chapter 11 of this Manual; however, there may be site-specific elements that are not addressed in Chapter 11.

TABLE 4.3 TYPICAL DESIGN SEQUENCE⁽¹⁾

Subject	Manual Section
I. Site Contour Survey Data	
A. USGS Topographic Maps Hazard potential Watershed area	6.4.1.1
B. Aerial Photography Embankment and pond area: five-foot minimum contour interval (two-foot interval is preferable) Spillway and outlet works: five-foot minimum contour interval (two-foot interval is preferable)	6.4.1.4
II. Review of Available Publications and Data	
A. Soils and Geology Government agencies: <ul style="list-style-type: none"> • United States Geological Survey (USGS) • Natural Resource Conservation Service (NRCS, formerly SCS) • State geologic survey(s) Other Sources: <ul style="list-style-type: none"> • Universities • Studies from nearby sites • Coal mine exploration borings • Aerial photographs 	Chapter 6
B. Hydrology Data Government agencies: <ul style="list-style-type: none"> • National Weather Service • USGS gaging station data • NRCS runoff data 	Chapter 9
C. Mining Status Coal operator's records Government agencies: <ul style="list-style-type: none"> • Office of Surface Mining, U.S. Department of the Interior • State agencies 	Chapter 8
D. Seismicity U.S. Geological Survey (USGS) Published records of recorded earthquake epicenters	7.7
III. Site Reconnaissance	
A. Area Upstream and/or Upgradient and Downgradient from the Facility	6.4.2, 14.4.2
B. Reconnaissance of Natural Features Topography and morphology Soil conditions, rock outcrops, sinkholes Vegetation cover Drainage patterns, springs and streams Erosion Stability (sliding and sloughing) Wetlands	6.4.2
C. Reconnaissance of Man-Made Features Roads and railroads	6.4.2

TABLE 4.3 TYPICAL DESIGN SEQUENCE
(Continued)

Subject	Manual Section
Buildings and other structures	
Bridges	
Stream modifications and channels	
Mine entrances and features (shafts, boreholes, highwalls, auger holes, spoil/refuse, AMD discharges, mine subsidence features, etc.)	8.3
Other infrastructure (gas wells, pipelines, power lines, etc.)	
Water treatment facilities	
<hr/>	
IV. Site and Facility Configuration Selection	
<hr/>	
A. General Considerations	Chapters 3, 5
B. Geotechnical Considerations	Chapters 6, 7, 8
C. Drainage Considerations	Chapter 9
D. Environmental Considerations	Chapter 10
E. Equipment and Construction Considerations	Chapter 11
<hr/>	
V. Field Investigations	
<hr/>	
A. New Facilities	
<u>Borings</u> – Locations, depths and types of sampling should be selected by an experienced designer.	6.4.3
<u>Geophysical surveys</u> – Supplemental to borings for exploration and testing.	6.4.4, 8.3.2
<u>Piezometers</u> – Normally piezometers are required only in selected borings for monitoring water levels in abutments, etc. or to determine if water conditions will create construction difficulties.	6.4, 13.4.2
<u>Test pits</u> – Test pits can be used to economically gain additional data in area planned for facilities and adjacent areas where borrow material may be obtained.	6.4.3.3
<u>Water samples</u> – Normally from surface water streams, major springs, and ground water wells.	10.3
<u>Field mapping</u> – Notation should be made of major spring locations, rock outcrop zones, mine openings, evidence of subsidence, existing landslides and any other conditions that might affect construction of refuse facility structures.	6.4.2, 8.2
B. Existing Facilities	
<u>Borings</u> – Locations, depths and types of sampling should be selected by a qualified engineer.	6.4.3
<u>Geophysical surveys</u> – Supplemental to borings for exploration and testing.	6.4.4, 8.3.2
<u>Piezometers</u> – Since phreatic conditions in an existing facility cannot be accurately estimated, piezometers should be installed in borings critical to stability analyses.	6.4, 13.4.2
<u>Test pits</u> – Test pits can be used for the same purpose as for new facilities, plus to evaluate the nature of weathering with depth, to obtain large samples of existing embankment materials, and to conduct in-situ density tests.	6.4.3.3
<u>Water samples</u> – From stream above and below facility, from the impoundment (if any) and from all major downstream seeps or springs. Also, from groundwater wells.	10.3
<u>Field mapping</u> – Same as for new facilities, plus observation should be made to locate any seepage zones on downstream face and to note any evidence of cracking or movement on any portion of the existing facility.	6.4.2, 8.2
<u>Flow measuring weirs</u> – Weirs or calibrated pipes should be installed to monitor the flow from any major seepage zone noted on the downstream face of the facility.	13.4.3
<u>Survey monitoring</u> – If any evidence of movement of the existing facility is noted in a critical zone, survey monuments can be installed to determine if the movement is active and the rate of movement.	13.4.1

TABLE 4.3 TYPICAL DESIGN SEQUENCE
(Continued)

Subject	Manual Section
VI. Laboratory Investigations	
A. Soils/Rock and Refuse Materials	6.5
General and index properties:	
• Water contents of all samples	
• Grain-size analysis of representative samples	
• Liquid and plastic limits of fine-grained materials	
• Specific gravity of refuse materials	
Materials behavior:	
• In-situ properties	
On Shelby tube samples or prepared samples for approximating in-situ conditions	
Strength tests with representative pore-pressure conditions	
Consolidation of fine-grained materials	
Hydraulic conductivity tests	
• Materials to be used for construction	
Compaction tests	
Strength tests with representative pore-pressure conditions	
Consolidation of fine-grained materials	
Hydraulic conductivity tests	
Special tests for refuse materials:	
Ash content and ignition tests	
B. Water Quality Testing	Chapter 10
The water quality testing program will be a function of the potential source of water, environmental conditions, and specific facility design features (may require determination of pH, temperature, specific conductance, suspended and dissolved solids, sulfates and metals).	
VII. Analyses and Design	
A. General Considerations	
Hazard classification	Chapter 3
Site development and startup	Chapters 4, 5
Erosion and sedimentation control	Chapters 5, 6, 9
Staging	Chapters 5, 6
Reclamation and abandonment	Chapters 5, 6, 10
B. Geotechnical	
<u>Parameters</u> – Establish material properties from field/laboratory data and/or other sources. For new facilities the properties of refuse may have to be estimated based on coal seam and preparation procedures because the material may not be available.	6.4, 6.5
<u>Geometry</u> – Establish basic embankment cross section configuration for each stage, including methods for controlling seepage.	Chapters 5, 6
<u>Static stability</u> – Estimate pore pressure conditions for critical stages or conditions. Modify geometry if required to achieve satisfactory static stability conditions.	6.6.4, 6.6.5
<u>Dynamic stability</u> – Perform seismic hazard assessment, liquefaction, stability, and deformation analysis, as required, considering hazard classification of embankment and seismic risk zone of site. Modify geometry if required to achieve satisfactory dynamic stability.	Chapter 7
<u>Settlement</u> – Evaluate if settlement of soft layers could cause loss of freeboard, embankment cracking or damage to drainage facilities.	6.6.3

TABLE 4.3 TYPICAL DESIGN SEQUENCE
(Continued)

Subject	Manual Section
<u>Subsidence</u> – Evaluate if underground mining could affect stability.	Chapter 8
<u>Buried pipe design</u> – Analyze pipe stresses and strain, select materials, and design installation and backfill requirements for conduits and decant pipes.	6.6.6
<u>Special considerations:</u>	
<ul style="list-style-type: none"> • Determine special foundation preparation requirements, including treatment of existing mine spoil or refuse. 	Chapters 6, 8
<ul style="list-style-type: none"> • Design special material requirements such as starter embankments, drainage materials, filters and soil cover or intermediate layers, if any. 	Chapter 11
<ul style="list-style-type: none"> • Establish special construction requirements for diversion ditches, spillway cuts, structure and pipe foundations, etc. 	11.7
<ul style="list-style-type: none"> • Specify borrow areas for required soils and rock materials. 	6.2.3.4
<ul style="list-style-type: none"> • Specify construction procedures to satisfy design assumptions. 	11.1
C. Hydrology and Hydraulics	Chapter 9
Determination of design storms	9.5
<ul style="list-style-type: none"> • Establish requirements for critical stages such as facility startup or abandonment. 	
<ul style="list-style-type: none"> • Establish basic storage-decant-spillway scheme 	
Sedimentation Control	9.4.4
<ul style="list-style-type: none"> • Establish sedimentation pond requirements. 	
Decant and spillway systems	
<ul style="list-style-type: none"> • Perform hydrology analyses for storm served only by storage and decant 	9.6
<ul style="list-style-type: none"> • Design decant system 	9.7.4
<ul style="list-style-type: none"> • Perform hydrology analyses for maximum design storm 	
<ul style="list-style-type: none"> • Design spillway structures (or cuts) for various stages 	9.7
<ul style="list-style-type: none"> • Design erosion protection system and/or stilling mechanisms. 	
Diversion Systems	Chapters 9, 10
<ul style="list-style-type: none"> • Design size of diversion ditches for various stages, including abandonment. 	
D. Special Considerations	
<u>Environmental protection</u> – Evaluate potential acid generation and seepage quality, and determine containment or neutralization requirements.	Chapter 10
<u>Corrosion</u> – Evaluate probable seepage quality and related limitations on construction materials.	6.5.2.5, 6.6.6.1, 11.7
<u>Vegetation</u> – Determine requirements for vegetation of completed surface, including the need for soil cover or surface preparation and treatment.	Chapter 10
<u>Monitoring</u> – Design monitoring and inspection program commensurate with the total design.	Chapter 12
<hr/>	
VIII. Preparation of Design Documents	
<hr/>	
A. Designer's Report Contents	Chapter 11
Introduction	
History (for existing sites)	
Discussion of site conditions and previous mining/site development/refuse disposal	
Field investigations	
Laboratory testing	
Geotechnical analyses	
Hydrology and hydraulics analyses	
Special considerations	
Facility staging	

TABLE 4.3 TYPICAL DESIGN SEQUENCE
(Continued)

Subject	Manual Section
Recommended design	
Abandonment requirements	
Monitoring and inspection	
B. Plans	Chapter 11
Location map	
Location plan on USGS quadrangle base	
Plan of borings and field investigation	
Boring and test pit logs	
Laboratory data	
Hydrology data	
Results of stability analyses	
Plans of facility at critical stages	
Plan and cross sections of hydraulic structures	
Details of hydraulic structure components	
Capacity curves for control sections of hydraulic structures	
Details of monitoring installations	
C. Specifications	Chapter 11
Site preparation	
Foundation preparation	
Embankment construction and internal drainage facilities	
Surface drainage facilities	
Decant system	
Emergency spillway construction	
Instrumentation	
Reclamation and abandonment	
D. Calculation Brief (should include input files for computer runs)	Chapter 11
Coal refuse production rates (by weight and volume)	
Starter embankment and staging	
Hydrology and hydraulics analyses (sedimentation control, design storm routing, drainage channel design, dam breach analysis)	
Stability analyses (including seismic hazard assessment and stability analysis)	
Settlement analyses	
Seepage analyses and internal drain design	
Surface drainage channel lining design	
Buried pipe analyses	
Environmental analyses	
E. Operation and Maintenance Plan	Chapter 11

Note: 1. The design procedure should be modified appropriately to suit the size, arrangement and specific characteristics of the facility being designed.

Chapter 5

COAL REFUSE DISPOSAL FACILITY DESIGN COMPONENTS

Coal refuse disposal facility design involves the evaluation of a number of interrelated components for development of an embankment that can accommodate refuse generation rates, storm water and environmental control requirements and provide a stable structure consistent with the operational demands of the mine and post-mining, land-use intentions. The detail and extent of analysis required for evaluation of each of these components depends upon the type of refuse facility being considered. The process of designing a disposal facility normally starts with determination of the refuse disposal volume requirements and, for slurry impoundments, includes consideration of the refuse generation rates and the design storm runoff volume that may need to be temporarily retained. Foundation conditions and possible required treatment, either resulting from existing soil conditions or past mining practices (underground or surface), may influence the locations of disposal facility structures and the overall configuration of the site, resulting in a need for special structures and instrumentation. The following components are normally evaluated as part of the design of a refuse disposal facility:

- Disposal capacity requirements, facility configuration/staging and scheduling
- Design storm management and erosion and sediment control
- Facility configuration, geometry and stability
- Foundation and mine subsidence considerations
- Stability of all embankment, channel and other site slopes affected by construction
- Internal drainage for embankment/foundation seepage control
- Decant and emergency spillway requirements
- Surface drainage controls
- Instrumentation and monitoring requirements
- Reclamation, abandonment and post-mining land use

5.1 DISPOSAL CAPACITY REQUIREMENTS AND SCHEDULING

5.1.1 Refuse Generation Rates and Design Capacity/Life

Refuse generation rates are the basis for determining disposal facility construction scheduling and the life of a disposal site. The refuse generation rate can be estimated based upon process flow and coal preparation studies for the new mine development and sampling, testing and volume data from existing disposal sites. Process flow data typically provide refuse generation rates for coarse refuse

and fine refuse separately on a dry-weight basis, along with estimates of the moisture content (either as percent moisture or percent solids for slurry). To estimate the disposal capacity and life of a facility, a conversion of the process data on a weight basis to in-place disposal data on a volume basis is required. Where sampling and testing data are not available, estimates of the in-place refuse properties must be developed, typically by using data from similar processing plants, coal strata, and refuse disposal sites. The in-place refuse properties required for initial estimation of the life and scheduling of a facility normally include unit weight/density and moisture content of both coarse and fine refuse. Ultimately, engineering properties of the refuse will also be required for designing the facility. These properties should be verified during the initial phases of the operation of the facility and at periodic intervals during the facility life. Available test data should be scrutinized to verify that they are representative, and the reliability and potential for variability of the refuse material should be evaluated. Provisions for verification of material properties and a schedule for doing so should be indicated in the design plans.

The design capacity and construction scheduling for a disposal site is also dependent on the planned configuration of the facility, as well as the type of handling of the fine refuse (slurry, filter cake, or mixed with coarse refuse). Based on an assumed site configuration, the capacity and life can then be estimated based upon the computed volume and refuse generation rates.

While the type of handling and processing used for the fine refuse is typically an operational decision, physical characteristics of fine refuse when disposed may impose certain limitations at the disposal site. For instance, past undermining may preclude the option of a slurry impoundment or may entail extensive foundation treatment that makes that option infeasible. Therefore, knowledge of the planned type of handling proposed for the fine refuse prior to selecting a site configuration for the refuse facility is important.

5.1.2 Slurry Impoundment Staging and Scheduling

The staging and scheduling of the construction of a slurry impoundment must be carefully analyzed so that the embankment elevation is sufficient to provide storage to contain the slurried fine refuse generated as well as the runoff from a design storm. Additional embankment height to account for material consolidation or permanent seismic deformations may also be needed. In general, additional embankment height and width can be added to provide design conservatism and enhance safety. Although the overall capacity of a slurry impoundment disposal site configuration can be estimated from the refuse generation rates, the rate of incremental construction of embankments or dikes must be sufficient to accommodate the generation and deposition of fine refuse slurry (referred to as staging). Additionally, storm runoff entering the impoundment will need to be stored temporarily, increasing capacity requirements. Short-term design storm criteria are applicable during initial site construction with transition to long-term criteria during subsequent development. Other factors that may enter into the staging of a slurry impoundment include the following:

- Initial construction of the beginning embankment or dike for impounding slurry (termed “starter dam,” “starter embankment” or “starter dike”) typically requires borrow material. The size of this embankment is optimized based upon the available borrow material, topography of the disposal site (which affects the initial slurry capacity), and the ability to schedule subsequent embankment or dike construction using solely coarse refuse to impound slurry at the expected refuse generation rates. Therefore, the reliability and consistency of refuse generation rates is important to the construction of embankment stages and operation of the impoundment.
- Availability and capacity of existing disposal facilities at the mine that could be used for temporary disposal during site development activities and while the starter embankment is being constructed.

- Amendments to the refuse or co-disposal of combustion waste with refuse, particularly when such additional material is a significant fraction of the refuse.
- The type of construction staging (upstream, downstream and centerline) will affect the capacity and schedule for the facility. Upstream construction utilizes less coarse refuse to achieve a comparable impoundment capacity because the stages are constructed partially on the settled fine refuse in the impoundment. Downstream, and to a lesser extent, centerline construction staging require greater quantities of coarse refuse to achieve equivalent impoundment capacity in comparison to upstream staging. At some sites a combination of upstream and downstream staging is employed to meet site configuration or specific refuse disposal requirements and to control excess pore pressures by initiating loading and consolidation of the fines early in the project life.
- In areas subject to seismic loadings, where deformation of the embankment may occur, additional freeboard between the impoundment surface and embankment crest may be necessary.
- Other special considerations such as impoundment breakthrough potential into underground mines, mine subsidence, reclamation, and post-mining land use can also influence the staging and configuration of the disposal facility.

When determining the type of construction staging (downstream, upstream, centerline, or a combination thereof), the ratio of coarse refuse to fine refuse generated by the preparation plant is a major factor. When the coarse refuse to fine refuse ratio is relatively high, downstream and centerline staging is normally preferred. As the coarse to fine ratio decreases, upstream staging is normally employed so that sufficient embankment height and containment is provided. As indicated above, both upstream and downstream staging may be employed at a site. [Figure 5.1](#) illustrates a construction sequence with upstream and downstream staging through Stage II. In this example, an early stage of upstream construction (Stage II-A) is incorporated in order to initiate consolidation of fine refuse, while disposal simultaneously occurs in a downstream stage (Stage II-B). The figure also shows several of the key components in facility design.

The amount of refuse generated and the coarse to fine ratio must be confirmed from actual production measurements and must be rechecked periodically during operation. These parameters should be periodically evaluated so that the staging of the refuse facility can be modified, if needed. In general, downstream construction results in more predictable embankment performance and may require substantially less testing and engineering to address seismic loading, but this type of staging is more sensitive to changes in the coarse to fine ratio.

5.1.3 Slurry Cell Staging

If slurry cells are designed and operated as small ponds with size and hazard potential classification that do not require impoundment plans under 30 CFR § 77.216, or are arranged such that a low-hazard-potential impoundment classification results, their staging and construction may be more complex than construction of an impounding refuse facility. A slurry cell facility typically has surface diversion to prevent runoff from collecting in the cells. Thus, the design storm plays a significantly smaller role in slurry cell staging than would be the case with a significant- or high-hazard-potential slurry impoundment. Additionally, when the slurry cells are covered sequentially with layers of coarse refuse, the fine refuse may be densified, but this effect typically does not greatly affect the capacity of a slurry cell facility.

[Figure 5.2](#) illustrates the components of a slurry cell facility. The small size of individual slurry cells necessitates operation of multiple cells, and in some instances, continuous cell construction, putting greater operational demands on the disposal facility. Thus, staging can be critical with a slurry

cell facility because the need to divert runoff around the cells and to periodically cover the cells can require as much or more coarse refuse than with slurry impoundment staging. Thus, the consistency of the refuse generation rate is critical to successful operation of slurry cells. Slurry cells are an attractive option only when there are limitations to developing an impoundment at a disposal site, or when the ratio of coarse refuse to fine refuse is quite large. Slurry cells are sometimes used as a contingency alternative when underground injection is employed.

When slurry cells are operated only to dewater fine refuse slurry, operation and staging difficulties are significantly reduced. For this type of operation, slurry is placed in cells for dewatering and subsequent removal and mixing with coarse refuse prior to final disposal. Typically, these slurry cells are utilized for refuse processing plants with lower production rates that are operated over a longer period of time, thus reducing the burden of continually constructing storm water diversion structures for new cells.

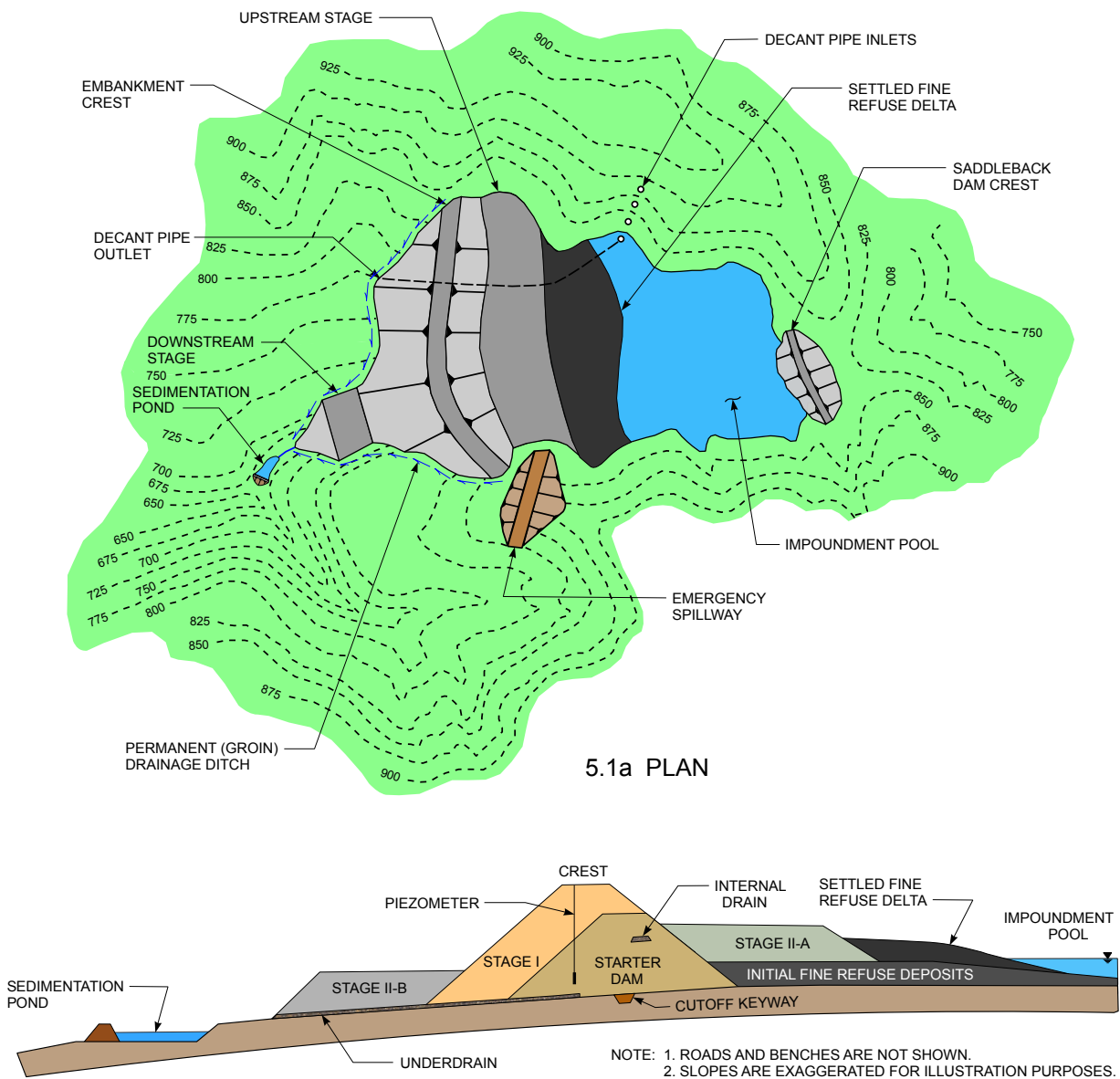

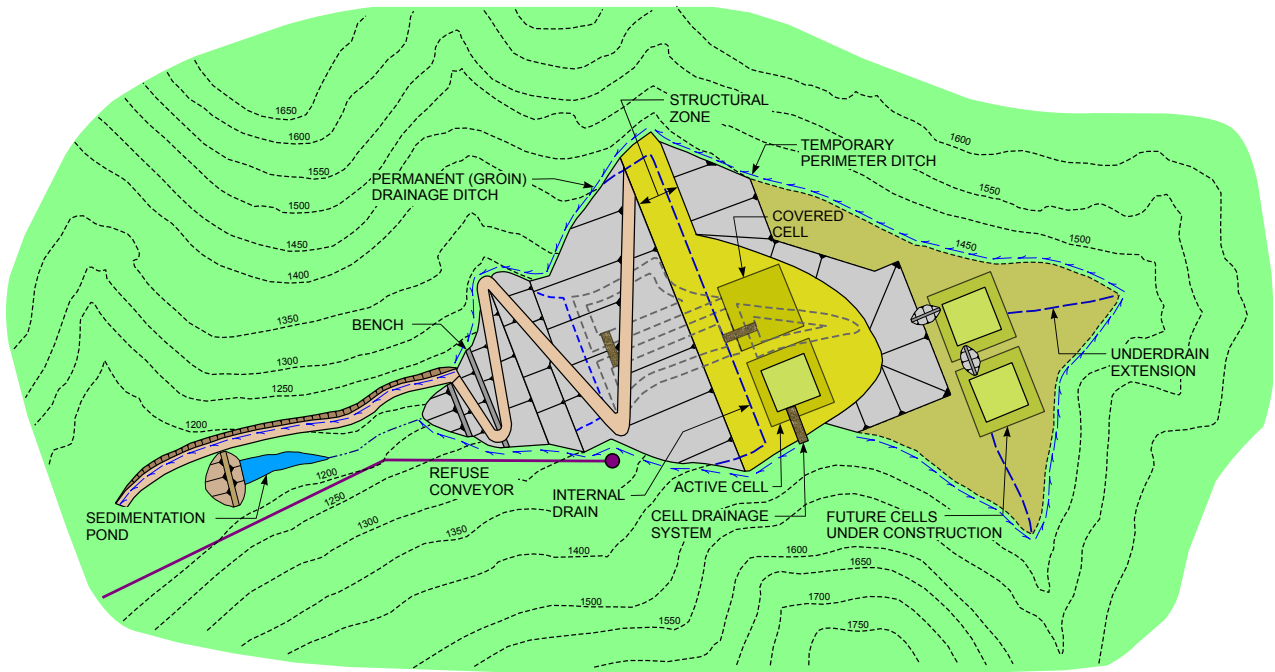

5.2a PLAN

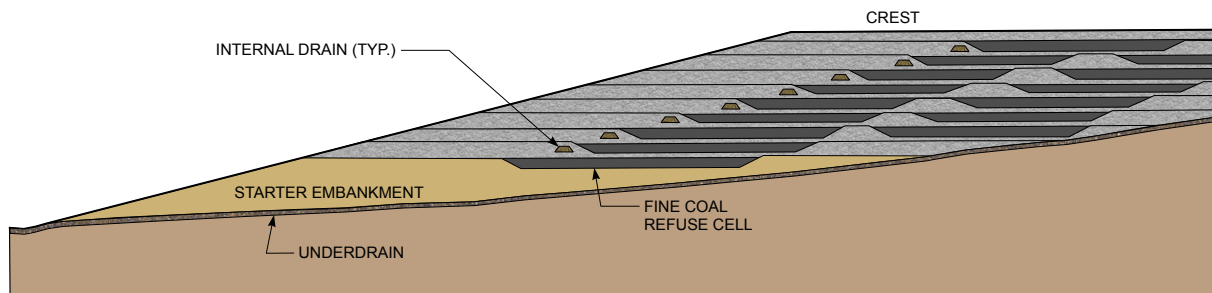

NOTE: ROADS AND BENCHES NOT SHOWN ON CROSS SECTION.

5.2b LONGITUDINAL CROSS SECTION UPON COMPLETION

FIGURE 5.2 TYPICAL SLURRY CELL FACILITY (IMPOUNDING EMBANKMENT)

5.1.4 Non-impounding Refuse Embankment Staging

Staging for non-impounding embankments involves surface runoff diversion, drainage provisions for significant springs or groundwater flow, erosion and sedimentation control, construction sequencing (upstream or downstream construction), and reclamation. When dewatered fine refuse is disposed within upstream zones of a non-impounding embankment, staging is a function of: (1) the required quantity of coarse refuse and the rate of construction of the well-compacted downstream shell (sometimes referred to as the structural zone), (2) haul road requirements, and (3) surface runoff diversion requirements. The construction sequence and reclamation planning will also affect the staging.

Figure 5.3 illustrates the components of a coarse refuse disposal facility. Surface runoff diversion and erosion and sedimentation controls influence staging. Because the working surface and some por-

tions of the embankment slopes will be exposed refuse, surface runoff from the embankment must be controlled separately from runoff from non-disturbed areas and must be directed to erosion and sedimentation control structures. This requires that flows from the contributing natural watershed be diverted around the disposal facility, which may require ditches or channels constructed upstream from the embankment or integrated into the embankment perimeter.

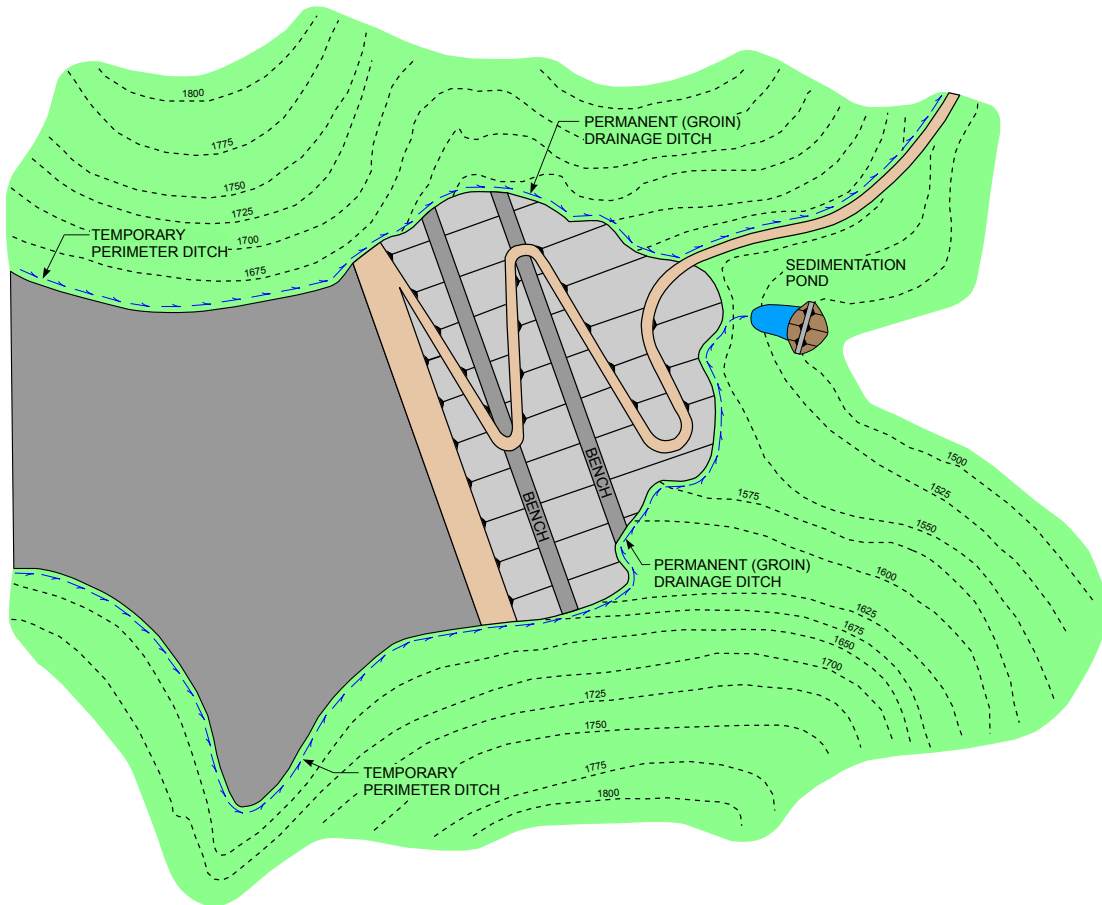

5.3a PLAN

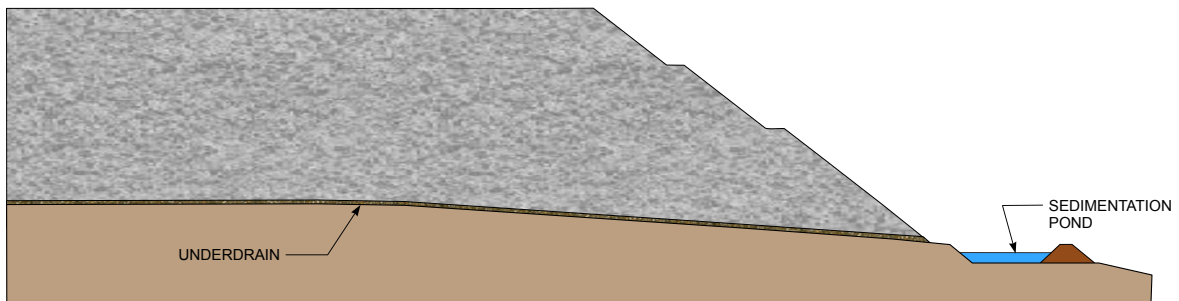

NOTE: 1. ACCESS ROAD NOT SHOWN IN CROSS-SECTION VIEW.
2. SLOPES ARE EXAGGERATED FOR ILLUSTRATION PURPOSES.

5.3b LONGITUDINAL CROSS SECTION

FIGURE 5.3 TYPICAL REFUSE EMBANKMENT COMPONENTS

5.1.5 Amendments and Co-disposal of Combustion Waste

The use of amendments applied to coal refuse and co-disposal of combustion waste and coal refuse will influence staging dependent upon the quantity of the materials disposed. Other aspects of embankment design may be affected because the engineering properties of the amended/combined materials may be different from those of the coal refuse.

5.1.5.1 Amendments for Neutralization and Stabilization of Refuse

Amendments applied to coal refuse have included a variety of materials typically used to neutralize the potential acidity of coal refuse or to absorb moisture for stabilization of the refuse during placement and compaction. Amendments have included lime and lime products, kiln dust, and combustion waste.

The inclusion of amendments for neutralization or stabilization of refuse may also have the following influences on design of the disposal facility:

- Neutralizing agents if applied in quantity can affect the strengths of the fill (either increase or decrease), and may alter handling and placement equipment requirements and embankment slopes. The thoroughness of mixing the amendments with the refuse is important to their application as neutralizing or stabilizing agents and affects the properties of the combined material.
- Runoff from neutralizing agents can have a high pH and thus may need to be retained within treatment ponds prior to discharge into a receiving water body.
- The hydraulic conductivity of the amended embankment materials may be lower than the refuse materials, necessitating additional internal drainage measures and resulting in precipitates that clog filters and internal drainage structures unless they are appropriately designed.
- Final reclamation of completed surfaces of amended embankment materials may be facilitated, allowing a thinner soil and topsoil cap.

To assess the behavior of mixed refuse and amendments, physical properties, including strength and hydraulic conductivity should be evaluated.

5.1.5.2 Co-disposal of Combustion Waste

Several types of combustion waste have been co-disposed with coal refuse at disposal sites, including: fly ash and bottom ash, fluidized bed combustion (FBC) ash, and flue gas desulfurization (FGD) sludge (dewatered). Depending on the characteristics of the waste, it has typically been disposed with coal refuse as: (1) part of contracting opportunities, (2) for structural or filter zones, (3) for stabilization of refuse due to wet conditions, (4) for neutralization of potential acidity of refuse, and (5) for reclamation improvements.

Co-disposal of combustion waste may have the following effects on the design of a disposal facility:

- The extent of mixing of combustion waste with coal refuse will affect the homogeneity of the embankment, particularly with respect to strength and hydraulic conductivity because of the influence of the combustion waste on these characteristics. The presence of mixed and unmixed layers may result in stratified conditions within the embankment.
- Combustion waste if incorporated within a refuse embankment in quantity may result in different (higher or lower) strength characteristics of the fill, requiring different handling and placement equipment and modified embankment slopes. FBC ash, if pozzolanic, will exhibit high strength at low strain similar to soil cement.

- The hydraulic conductivity of the embankment materials mixed with combustion waste may be different (typically lower, but possibly higher) than the refuse materials alone. This may result in precipitates that clog filters and internal drainage structures necessitating additional internal drainage measures. Combustion waste may also increase the anisotropy of embankment materials.
- FBC may have expansive characteristics that can affect instrumentation performance and monitoring, influencing the position and elevation of survey monuments and the verticality and integrity of casings for piezometers and inclinometers.
- Use of combustion waste may increase dust control requirements at the embankment surface.
- Runoff from combustion waste can have high pH and thus may need to be retained within treatment ponds prior to discharge to the receiving water body.
- Final reclamation of completed surfaces of embankment materials with co-disposed combustion waste may be facilitated, allowing a thinner soil and topsoil cap.
- Combustion waste may contain metals that can result in leachate and groundwater impacts.

Research on the beneficial use and co-disposal of combustion waste with coarse coal refuse is reported in Daniels et al. (2002). Research on co-disposal of combustion waste with fine coal refuse is presented in Kumar et al. (2001).

5.2 EROSION AND SEDIMENTATION CONTROL AND DESIGN STORM RUNOFF MANAGEMENT

Erosion and sedimentation control features are required for all disposal facilities, and their design must be integrated into the overall drainage control plan. Management of runoff from design storms is a function of the type of refuse disposal facility and associated design storm. Impounding facilities are typically designed to retain a portion of design storm flows within the impoundment, thus attenuating the peak flow. Non-impounding embankments utilize diversion channels and ditches that are designed to handle the peak discharge. Embankments for both impounding and non-impounding facilities typically have associated drainage channels and ditches that are designed to handle storm flows. For larger refuse facilities, erosion and sedimentation controls can represent a significant component in the overall design of the facility and can occupy a relatively large portion of the site that should be accounted for during the initial phases of design.

5.2.1 Erosion and Sedimentation Control

Erosion and sedimentation control requirements are generally based on state regulatory criteria. Their function is to divert runoff from undisturbed areas of a site and to collect and treat runoff from disturbed areas. Diversion systems are normally required for all refuse embankments; however, impoundments can serve to provide sediment control for their contributing watershed. The design of the erosion and sedimentation control system is based upon the disturbed area at the disposal facility during operation and as reclamation is performed.

Sediment control is typically provided by ponds that receive drainage from the embankment and disturbed areas, and these are typically located near the downstream toe of the disposal facility. As discussed in Chapter 9, the ponds are designed with decant systems and inlet structures that provide adequate capacity and settling time for removal of sediment and control of storm events without activating the emergency spillway. The design of the emergency spillway is based on the pond's hazard-potential classification and applicable state criteria.

5.2.2 Slurry Impoundment Inflow Design Storm

Selection of the appropriate design storm (short- and long-term) is a function of the hazard potential of the planned slurry impoundment. Based on the design storm and site conditions, the runoff rate and volume can be determined. The facility can then be configured to manage the design storm through a combination of storage and routing. The runoff volume is important because frequently the size and configuration of the outlet system (decant pipe or spillway) for impoundments are determined by the volume of water that must be evacuated from the impoundment within a certain specified time period after the storm event (Chapter 9). Similarly, the staging of the facility must be adequate to retain the runoff from the design storm with adequate freeboard.

High-hazard-potential facilities must be able to handle the most severe design storm, while a lesser magnitude storm will be suitable for a significant- or low-hazard-potential classification facility. The determination of the hazard-potential classification is discussed in [Section 3.1](#). Dam breach analyses may be performed as part of hazard-potential determination, as discussed in Chapter 9.

Short- and long-term embankment design criteria must be evaluated in the determination of the design storm, typically to address conditions during the first two years of construction and operation, as the impoundment is being developed, and during the last two years of the facility's life, when it is being reclaimed. Short- and long-term design criteria are discussed in Chapter 9, as part of the hydrologic and hydraulic engineering analyses, and are primarily a function of the hazard potential and the size of the planned impoundment. For example, during the initial year of construction and operation of a large, high-hazard-potential impoundment, the capacity to handle the 100-year storm may be needed; during the second year the $\frac{1}{2}$ Probable Maximum Flood ($\frac{1}{2}$ PMF) event; and within two years the full PMF event. Short-term criteria are intended for unavoidable construction conditions during initial start-up and abandonment and should only be utilized when absolutely necessary.

Impoundments are typically designed to: (1) store the runoff from the design storm with slow release of the runoff through a decant pipe system, (2) release the design storm runoff without storage through an open-channel spillway, or (3) store a portion of the design storm runoff and release the balance through an open-channel spillway. [Figure 5.4](#) illustrates the concepts of 100-percent storage of the design storm runoff and the use of an open-channel spillway to route the design storm runoff. An impoundment that is designed to store the design storm runoff with release through a decant ([Figure 5.4a](#)) requires greater surcharge storage capacity than an impoundment that employs an open-channel spillway ([Figure 5.4b](#)). The determination of the magnitude of the design storm, including the short- and long-term criteria upon which the design storm is based and associated runoff rates and volumes, is discussed in Chapter 9.

Drainage channels at other locations at impoundment facilities, such as the downstream embankment face, are typically designed for the 100-year storm, and these structures do not affect the overall configuration, geometry and staging of embankment construction. However, if impoundment decant systems discharge to embankment drainage channels, the discharge should be added to the surface flow collected by the drainage channels. If the drainage channels intercept a substantial amount of runoff, the design storm criteria for the impoundment may need to be applied to the channel design in order to protect the embankment from erosion during a severe flood.

5.2.3 Slurry Cell Facilities

Slurry cell systems are attractive in situations where they can be kept under the size and hazard thresholds of 30 CFR § 77.216, or where they can be classified as having low hazard potential, so that design storm management can be based on the 100-year event and not the PMF. A low-hazard-potential determination requires information to substantiate that, in the event of a failure, the facility will not release water, sediment, or flowable fine refuse that would cause loss of life or significant property damage, as discussed in Chapter 3. Thus, the sequence of active and open

cell operation must be designed to minimize impounding capacity. Also, the closed and covered slurry cells must be oriented and dewatered such that they do not collectively represent a potential release of flowable material that would severely impact downstream development.

By achieving a low-hazard-potential classification or avoiding classification as a regulated impoundment, slurry cell systems can be designed for lesser design storm criteria (i.e., 100-year storm). Because the watershed area contributing to the slurry cells is minimal, only a small quantity of runoff has to be managed as part of the slurry disposal operation. While this reduces the influence of the design storm runoff on the overall configuration and staging of the slurry cell system, runoff from adjacent areas, particularly upstream watershed areas, must be diverted, which requires construction and maintenance of diversion channels that are incorporated into the embankment or disposal site configuration.

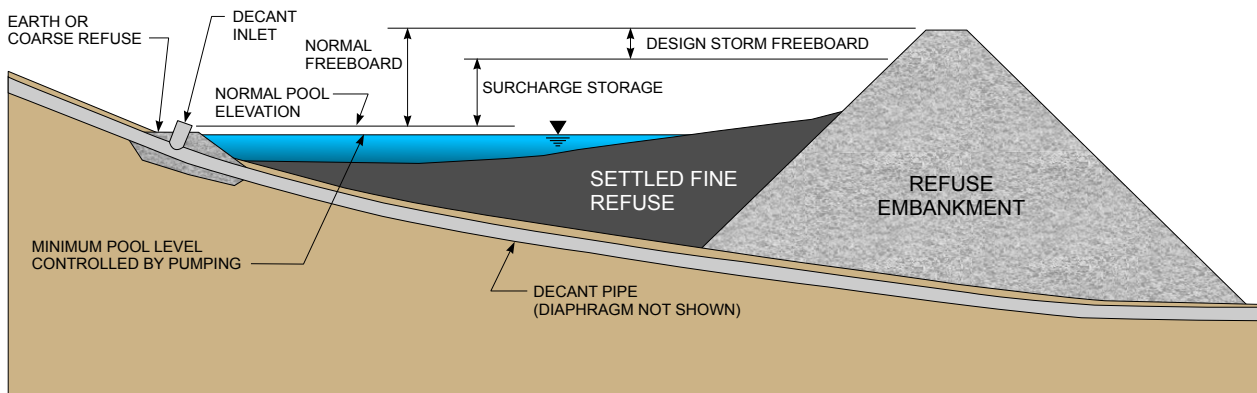

5.4a IMPOUNDMENT DESIGNED FOR 100-PERCENT STORAGE OF DESIGN STORM

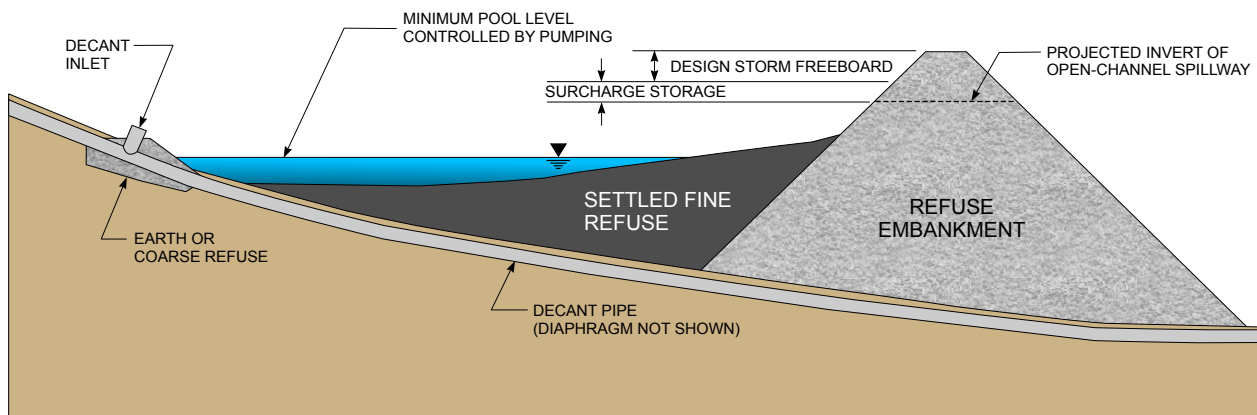

NOTE: SLOPES ARE EXAGGERATED FOR ILLUSTRATION PURPOSES.

5.4b IMPOUNDMENT DESIGNED WITH OPEN-CHANNEL SPILLWAY

FIGURE 5.4 ILLUSTRATION OF IMPOUNDMENT DESIGN STORM CONTROL

Drainage structures for slurry cells must have the capacity to control runoff from the design storm collecting within the cell, along with clarified water produced as the slurry is deposited. This drainage may be achieved by using a decant pipe with an appropriately sized inlet or riser to facilitate settling of the fine refuse. An open-channel spillway may also be needed depending on the slurry cell arrangement and contributing drainage area.

As with other site drainage not related to impoundments, the channels and ditches on the downstream face of a slurry cell embankment must be designed for the 100-year storm and do not affect the overall configuration or staging. If a slurry cell facility is designed as a significant- or high-hazard-potential impoundment, the associated design storm criteria may need to be used also for the design of embankment drainage channels that receive decant discharge.

5.2.4 Refuse Embankment Design Storm

The design storm for non-impounding refuse embankments is primarily used for sizing channels and ditches that divert or collect and convey drainage from the embankment, as part of the erosion and sedimentation control for the site. Diversion ditches are typically constructed around the perimeter of refuse embankments so that channel runoff from undisturbed portions of the site is conducted around the disturbed areas to sedimentation ponds. If a diversion ditch must be relocated to a higher elevation as an embankment is expanded, a plan of ditch relocation that provides for drainage diversion from disturbed areas during the associated construction must be prepared.

Permanent channels and diversion ditches should be designed for the peak discharge from the 100-year storm. Temporary channels may be designed for a lesser magnitude event, as discussed in Chapter 9. Long-term drainage control required during reclamation and abandonment should be incorporated into the drainage channel design.

5.3 FACILITY CONFIGURATION AND GEOMETRY

The configuration and geometry of a refuse disposal facility is a function of staging/construction methods, capacity requirements, engineering properties of the refuse, initial site topography, storm water management, regulatory criteria and overall facility stability requirements. Operational factors, such as refuse transport and handling equipment also influence the design and overall configuration of the facility.

5.3.1 Regulatory Criteria

Criteria have been established by federal (Office of Surface Mining) and state agencies that address some parameters for design of coal refuse disposal facilities. These parameters include embankment slope, which should not be steeper than 2:1 (horizontal to vertical) between benches. Benches are used to control erosion, retain soil moisture, or facilitate reclamation and are typically integrated into embankment slopes.

For slurry impoundments that are classified as dams by state agencies, regulatory criteria for the width of the crest and maximum slopes should be reviewed. Other regulatory criteria may affect the design configuration and geometry, as a result of required right-of-ways, buffer zones, and related off-sets from natural features, structures, utility lines and property lines. State and federal criteria may change with time.

Federal and state regulatory agencies require engineering analyses for demonstrating that certain design criteria are satisfied, such as the ability of the facility to safely route the design storm or to provide a specified factor of safety relative to stability. State criteria are sometimes different from federal criteria. Both should be considered, and the most stringent criteria should be applied.

5.3.2 Embankment Design Considerations

The following subsections provide a discussion of issues related to embankment design.

5.3.2.1 Stability under Normal Operating Conditions

Stability analyses are performed to determine the embankment configuration and slope. The parameters associated with these analyses include the following:

- Embankment material strengths – These strengths are dependent upon the types of refuse, borrow materials, and amended/co-disposed materials used in embankment construction, as well as the method of placement and compaction. Sufficient exploration and testing must be performed such that all applicable material properties can be accurately characterized.
- Foundation material strengths (as determined by exploration and testing) – These may be improved if necessary by removal and replacement or by ground improvement measures. Sufficient exploration and testing must be performed such that in-situ material properties can be adequately characterized.
- Seepage and phreatic level – These are a function of normal pool level, internal drainage systems and liner systems.

Non-impounding coal refuse disposal facilities are normally developed over several years, and, as with impounding facilities, the configuration may vary considerably during various stages of the facility's life due to upstream and downstream development. Stability analyses should be conducted at various points or critical stages in the embankment development. A detailed evaluation of the facility staging and construction should be performed to identify critical configurations that require stability analysis. Chapter 6 presents guidance related to stability analyses and other geotechnical engineering issues.

5.3.2.2 Stability under Extreme Events

Embankment stability under design storm and earthquake loading conditions (assumed to not occur simultaneously) must be evaluated. For design storm conditions, the embankment stability and configuration may be affected by the following:

- Flood level (peak pool level resulting from the design storm event) at an impoundment, which may affect the embankment phreatic surface and seepage conditions, depending on the depth and duration of the elevated reservoir level and the effectiveness of internal drainage measures.
- The location and elevation of decant and spillway structures.

Seismic analyses are performed on impounding embankments and sensitive embankments such as slurry cell facilities. Guidance for these analyses is presented in Chapter 7 and includes evaluation of strength loss or degradation of embankment or foundation materials as a result of seismic loading and evaluation of seismic deformations that may affect embankment performance. Design features that may be considered for mitigating the adverse effects of earthquake loading and associated embankment response include providing extra freeboard, enhancing internal drainage and related consolidation of the fine refuse, widening the embankment, and adding a buttress.

5.3.2.3 Settlement and Subsidence

Settlement of foundation soils or refuse materials, particularly if upstream construction is employed for an impounding embankment, may require placement of additional material to maintain crest elevations and grades of drainage structures. Large differential settlements may represent a risk of cracking of strain-sensitive materials (e.g., clay zones) or barriers, thus requiring measures to limit differential settlement. Chapter 6 provides guidance for settlement and other geotechnical analyses.

Subsidence associated with underground mines may affect the design configuration of the embankment and is discussed further in [Section 5.4](#).

5.3.2.4 Environmental Issues, Impoundment Elimination and Site Reclamation

Amendments to refuse or the presence of a liner system beneath an embankment or zoned embankment (for an impoundment facility) can affect the stability of the embankment, requiring modifications to configuration or slope. Reclamation, post-mining land use, and abandonment practices can also affect the embankment configuration and slope.

5.3.3 Impoundment Design Considerations

The impoundment configuration can also be affected by a range of design considerations, as described in the following paragraphs.

5.3.3.1 Settling and Clarification

Facilities such as polishing ponds, baffles, clear water cells, and similar structures may be required in order to produce water quality that is acceptable for discharge or preparation plant use. Clarification may also be accomplished in ponds downstream of the impoundment facility.

5.3.3.2 Seepage Control and Containment

To mitigate environmental impacts, seepage control and liner systems may be necessary for containment of the fine coal refuse.

5.3.3.3 Spillway and Decant Systems

Decant systems often serve as primary spillways and, if the watershed and impoundment sizes are compatible, may be sufficient to manage the design storm without an open-channel spillway. This will require that significant freeboard be maintained under normal operating conditions. In some instances, including during the final years of operation of a facility, open-channel spillways sized to handle the design storm are constructed, thus allowing more of the impoundment to be used for refuse disposal.

5.3.3.4 Subsidence and Breakthrough Potential

Subsidence analyses may identify potential impacts to an impoundment area, requiring changes in layout or other design features that affect the site configuration. Where mine workings are in proximity to an impoundment, evaluation of breakthrough potential may indicate that measures such as constructed barriers (embankment fills) are needed to buffer the zone of impact and maintain internal stability. These and other measures are addressed in Chapter 8.

5.4 FOUNDATION AND MINE SUBSIDENCE CONSIDERATIONS

5.4.1 Foundation Materials

Foundation materials must be evaluated relative to their strength, compressibility and hydraulic conductivity. Foundation materials without adequate strength, or with high compressibility, may not provide adequate support for the disposal facility, leading to detrimental movement or actual failure. Hydraulic conductivity is an issue primarily with impounding embankments, where high-hydraulic-conductivity foundation materials can lead to elevated pore pressures affecting local stability and creating the potential for internal erosion or piping of fine soil particles that can threaten the overall stability of the disposal facility. High-hydraulic-conductivity foundation materials can also lead to unacceptable loss of clarification water or, in extreme situations, release of impounded materials.

Strength and compressibility are typically concerns for foundation soils, while hydraulic conductivity may be a concern for both soil and bedrock conditions. Bedrock strength conditions can be an issue where weak layers, such as claystones, underlie an embankment and behave similarly to a soil (primarily where shallow or surface outcrop conditions occur). Weak or fractured bed-

rock conditions may also become an issue where underground mine workings are in proximity to an embankment or impoundment such that subsidence could cause differential movement and impose strain on structural components or drainage features of the disposal facility. An additional concern, as discussed in [Section 5.4.3](#), can be actual breakthrough of the disposal facility into mine workings.

A variety of measures to address foundation material concerns are available. These may include accommodations in the disposal embankment and impoundment design or in-situ foundation treatments ranging from removal and replacement of shallow, weak soils to grouting of fractured bedrock conditions. Seepage control within foundation materials typically is accomplished by constructing cutoff trenches through high-hydraulic-conductivity natural soils and weathered bedrock and backfilling with low-hydraulic-conductivity soils. Cutoff trenches may disclose geologic features such as alluvial deposits, sand dikes, and relief fractures that require treatment and that would not be revealed by exploration borings.

5.4.2 Abutment and Foundation Geometry

The geometry of the abutments and foundation (steep slopes and bedrock exposures) of an impounding embankment can lead to differential settlements resulting in cracking of embankment materials, disruption of drainage control features, and seepage concerns. This situation may be exacerbated at former surface mine sites where embankment construction is planned in areas of former highwalls. For non-impounding embankments, such concerns may also need to be addressed in the design of drainage control systems.

Measures to address steep foundation geometry may include benching and cutting back of slopes, zoning with select structural materials, and planned compensation fills in the embankment design to offset cumulative settlements. These issues are addressed in Chapter 8.

5.4.3 Mine Subsidence Potential

The presence of underground mines or the potential for future underground mining in the vicinity of a coal refuse disposal facility may influence the location and design of facility features. Additionally, auger or highwall mining can lead to subsidence and seepage concerns. Location of an impoundment facility in the vicinity of mine workings is of concern because of the potential impacts of subsidence on embankment stability and the related potential for release of impounded materials, as well as the risk of a breakthrough into the mine, which is discussed in [Section 5.4.4](#). Non-impounding facility design may also be influenced by potential mine subsidence, particularly related to impacts on structural elements and drainage and liner systems.

Depending on the depth to mine workings and proximity to the disposal facility, subsidence analyses may be needed for determination of the potential magnitude, tilt, curvature, and strain associated with ground movement related to subsidence. These analyses provide a basis for evaluation of the subsidence impact on the disposal facility and can help to identify potential mitigation measures. The engineering methodology for performing these analyses is presented in Chapter 8, and the potential impact of differential movement on coal refuse materials and structures is discussed in Chapters 6 and 8.

Similar analyses should be performed for proposed mining in the vicinity of disposal facilities. Only under very favorable conditions and where development is essential for haulage or ventilation should mining be performed under impounding embankments. The extent of mining that may be conducted under an impoundment is dependent upon the overburden and mining conditions. It is current practice that subsidence analyses are performed for longwall mines in order to establish a "safety zone" where extraction is precluded for protection of an impounding embankment.

Subsidence impacts associated with drainage control systems (liners, internal drains, and surface drainage systems) may be addressed through evaluation of potential differential movement and strain during design. When mine workings are present beneath or in the vicinity of an impoundment, the following design measures may be employed to mitigate potential subsidence effects on embankments:

- Maintenance of ample freeboard to compensate for the anticipated subsidence.
- Broad embankment configuration design that is less sensitive to subsidence impact or enhanced zoning of embankments with self-healing characteristics (e.g., cohesionless sand) to mitigate potential cracking and internal erosion.
- Allowance for potential subsidence effects in the design of internal drainage structures or implementation of enhanced seepage control measures (barriers and chimney drains) to minimize the effects of potential subsidence.
- Backfilling or grouting of mine entries in critical support areas to minimize the amount of movement that can occur.
- Installation of monitoring systems for detecting subsidence and associated impacts such as increased seepage and preparation of contingency plans for mitigating such impacts.

To address the potential for subsidence and seepage in areas of auger or highwall mining, backfilling and/or protection berms or embankments may be employed, as discussed in Chapter 8.

5.4.4 Impoundment Breakthrough Potential into Mine Workings

In addition to subsidence concerns, if the overburden separating an impoundment from existing mine workings is relatively thin, there is a potential for sinkholes or even catastrophic breakthrough of the impoundment into the mine workings. In general, areas where the cover over a mine entry comprises less than 100 feet of intact rock strata are a concern for sinkhole development. Even greater amounts of cover are cause for concern in some situations. In addition to possible sinkhole development, shearing or punching of a coal outcrop is another potential failure mechanism that must be prevented. Without proper design, failure can occur through the coal seam itself, through strata above the coal, or along material interfaces or discontinuities. Internal erosion along these interfaces and discontinuities must also be prevented.

The presence of auger or highwall mining workings adjacent to an impoundment can also be cause for concern. The potential for subsidence should be evaluated in design, and measures to control seepage and to address the potential for breakthrough into neighboring underground mine workings should be developed, as needed. [Figure 5.5](#) illustrates the presence of mine workings immediately adjacent to and beneath an impoundment and the use of a berm or barrier and internal drainage system to mitigate potential seepage and breakthrough potential.

Chapter 8 presents guidance for analyzing breakthrough potential and preventing breakthroughs. Some basic design measures that may be useful for mitigation of the potential for breakthroughs include:

- Development of a safety zone (based on verifiable data related to mining and outcrop or overburden conditions) that provides sufficient undisturbed ground between the mine and the impoundment so that the ground movement induced by mining will not affect the impoundment.
- Development of measures to provide adequate support for the impoundment considering potential failure mechanisms such as some combination of: (1) an engi-

needed barrier (soil or synthetic barrier) or berm (coarse refuse) to mitigate the failure mechanisms, (2) an internal drainage system to control seepage and to reduce pressures in the areas of potential breakthrough, or (3) stabilization of the fine coal refuse to increase strength and reduce flowability. Any mitigation measure employed must also be resistant to subsidence.

- Development of containment or diversion structures, such as bulkheads, within the affected mine workings.
- Stabilization of the mine workings that may affect the impoundment by mine filling and/or grouting to improve strength and resistance to failure mechanisms.

As an alternative to the berm illustrated in Figure 5.5, slurry cell configurations have been employed at some impoundment sites with breakthrough potential, or the operation has been converted to fine coal refuse paste in order to restrict the potential release of flowable material.

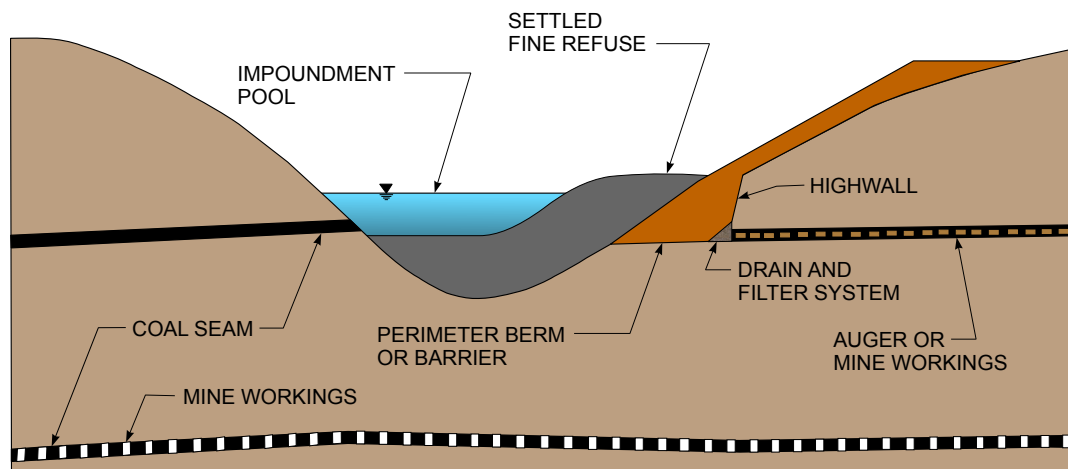

NOTE: SLOPES ARE EXAGGERATED FOR ILLUSTRATION PURPOSES.

FIGURE 5.5 UNDERGROUND MINING AT SLURRY IMPOUNDMENT

5.4.5 Mine Entry Barriers and Bulkheads

Where mining is occurring in the vicinity of a coal refuse disposal facility, barriers and bulkheads may need to be constructed for the purpose of controlling drainage and mitigating the potential for internal erosion and piping in the embankment. Mine entries may include mine openings, ventilation boreholes, auger holes, or highwall mining areas. The design requirements for barriers and bulkheads are dependent on the type of disposal facility, location of the entry, and presence of drainage entering into or discharging from the mine. For support of non-impounding embankments, only a barrier may be required, particularly if drainage conditions are not an issue. Entries beneath impounding embankments or beneath impounded water will probably require installation of a bulkhead and/or barrier along with additional measures for addressing drainage at the entry location or within the mine. As an additional line of defense, bulkheads should be considered at critical discharge locations. Chapter 8 provides guidance for the design of barriers and bulkheads.

5.5 INTERNAL DRAINAGE AND EMBANKMENT SEEPAGE CONTROL

Internal drainage and seepage control features are designed to accomplish: (1) collection of springs and hillside subsurface drainage and conveyance to a point downstream of the refuse embankment (and sedimentation ponds), (2) environmental containment using liner systems to control seepage to subsurface groundwater beneath the site, (3) collection of seepage and conveyance downstream to

treatment or sedimentation ponds, (4) control of the phreatic surface or foundation pore pressures to maintain embankment stability, and (5) prevention of seepage along penetrations (decants, etc.) through the embankment. Reclamation may also involve construction of a low-hydraulic-conductivity cap to limit infiltration and reduce internal drainage requirements.

Technical guidance for internal drainage and embankment seepage control is provided in Chapter 6 and covers the following:

- Seepage analyses for embankments (homogeneous and zoned), including analysis of the effects of foundation cutoffs, liners, and internal drains.
- Filter criteria for zoned embankments.
- Design of internal drains, including filters.

The environmental aspects of reclamation, internal drainage and seepage control are addressed in Chapter 10.

5.6 DECANT AND EMERGENCY SPILLWAY SYSTEMS

Hydraulic structures for controlling impoundment levels and providing storm routing are designed based on design storm runoff management, as discussed in [Section 5.2](#), with specific features influenced by the type of embankment staging employed (upstream versus downstream) and configuration (height and length of the disposal facility), site terrain, and foundation issues.

5.6.1 Decant Performance Considerations

Decant systems provide for discharge of clarified water from an impoundment. While a decant system may be a component of the design-storm water management system, in many cases the impoundment level may actually be controlled by pumping when the water surface level is below the decant invert. In cases where a decant system is part of the design storm management system, it is typically designed to provide sufficient capacity to evacuate at least 90 percent of the design storm runoff retained within the impoundment within 10 days, assuming that no design-storm runoff storage is available below the lowest ungated decant inlet. The 10-day period is measured from the time of peak impoundment pool during the design storm.

The design of decant systems involves the following considerations:

- Hydraulic capacity evaluation (head versus discharge analysis).
- Material selection, as affected by the length and depth of cover, foundation conditions, installation method, and other factors such as strength, flexibility, durability, corrosion protection, and joint type.
- Inlet design features, including riser pipe structural stability and support, trash guards, anti-vortex devices, and sealing requirements upon discontinuation of use.
- Alignment and grade, including variation in grade due to terrain, potential foundation settlement, the need for reaction blocks, resistance to flotation, and venting systems.
- Outfall design, energy dissipation requirements, and erosion protection.
- Pipe backfill, drainage diaphragms and seepage control.
- Monitoring/testing requirements.

If decant systems are designed to discharge to a groin ditch adjacent to the downstream embankment slope, additional design considerations may apply. In such instances, the peak decant discharge should be added to the surface flow collected by the groin ditch. If the ditch intercepts a substantial

amount of runoff, the design storm criteria for the impoundment may need to be applied to the ditch design in order to protect the embankment from erosion during a severe flood.

5.6.2 Open-Channel Spillway Performance Considerations

Many impoundments are designed such that the reservoir storage capacity and decant system discharge capacity provide for design storm runoff management, but sometimes a separate open-channel spillway is also required. These should be designed with a capacity that will allow routing of the design storm flow through the impoundment while maintaining adequate freeboard. Open-channel spillways are less commonly employed at refuse disposal embankments because of staged development. The following should be considered in the design of open-channel spillways:

- Hydraulic capacity (head versus discharge capacity) and minimum freeboard for the approach channel, control section, and discharge channel or conduit so that sufficient capacity is available for releases up to the design peak outflow. Measures to control floating debris or hillside trees that could cause obstructions may be required at the approach channel.
- Channel geometry, including considerations for transition sections (e.g., contraction section), changes in alignment (e.g., super-elevation at bends), and grade (e.g., sufficient capacity for hydraulic jumps).
- Stable channel conditions, considering excavation slopes as well as potential for erosion due to water flow associated with velocity/tractive force/duration on the channel lining. Channel linings require suitable foundation and drainage systems and should be designed for tractive and uplift forces.
- Energy dissipation structures at the spillway outlet.

If large-diameter conduits are used in conjunction with open channels or in place of an open channel, material selection, inlet design, alignment and grade, backfill, seepage control, and outlet design issues are similar to those for decant systems.

5.7 SURFACE DRAINAGE CONTROLS

Surface drainage controls at coal refuse disposal embankments typically consist of drainage ditches and channels, bench and haul road gutters, and culverts that collect and convey runoff to downstream structures.

5.7.1 Permanent Drainage Controls

Permanent drainage controls are structures that will be in service during operation of the disposal facility and following reclamation and abandonment of the facility. These structures should be designed for the 100-year-recurrence-interval storm. Typically, the 100-year, 24-hour-duration storm is used for design, consistent with state regulatory criteria.

The design of permanent drainage controls should be based upon the following considerations:

- Hydraulic capacity considering the peak discharge rate from the design storm for the contributing drainage area.
- Channel geometry, including accommodation for transition sections and changes in alignment (e.g., super-elevation at bends) and grade (e.g., additional capacity for hydraulic jumps in subcritical flow sections).
- Stable channel conditions, considering flow velocity/tractive force/uplift/duration for the channel lining, if the channel is not excavated in competent rock.
- Energy dissipation structures at channel outfalls.

5.7.2 Temporary Drainage Controls

Temporary drainage channels function periodically during operation, but are not part of the long-term surface water controls related to reclamation and abandonment. These may include temporary ditches for diversion or runoff collection within the disposal facility, bench and haul road gutters (before topsoil placement and reclamation), and most culverts. Temporary ditches and culverts may be designed with a hydraulic capacity lower than for permanent drainage controls, because of shorter service life and other criteria. For instance, state regulations or recommendations for some drainage structures may specify a 10- or 25-year-recurrence-interval storm. Temporary ditches may be designed without linings provided that: (1) their service life is relatively short and potential erosion damage can be readily repaired and (2) lack of linings will not cause adverse impacts to the safety of the disposal facility or compromise downstream sedimentation controls.

5.8 INSTRUMENTATION AND PERFORMANCE MONITORING

Instrumentation is typically a component of coal refuse disposal plans and is recommended for all high or significant-hazard-potential sites. Instrumentation records should be reviewed as they are accumulated. The data are best evaluated by maintaining a continuous plot of the readings versus time. The data should be reviewed as part of annual inspections and certifications and should be maintained for the life of the facility. The data review provides a basis for: (1) assessment of facility performance relative to design intentions, (2) detection of trends and problems that may develop, and (3) operational plan modification or facility expansion. Design plans should indicate maximum acceptable levels for instrument readings or percentage changes that trigger further investigation or actions. Facility performance will typically be enhanced by monitoring the parameters discussed in the following paragraphs with appropriate instrumentation:

5.8.1 Seepage

Seepage from the impoundment should be monitored for flow rate and changes in appearance (discoloration or appearance of fine particulates and precipitates). This monitoring should include seepage through the embankment, through internal drainage structures, and through underground mines that receive seepage from the impoundment. Weirs should be installed, preferably with a staff gauge in the weir approach pool, so that flow rates can be easily and accurately measured. To evaluate changes in seepage rates, it is important to know the impoundment pool level and to have data pertaining to rainfall and groundwater levels, so that possible correlations can be evaluated.

5.8.2 Piezometric Levels

Saturation levels and water pressures within an impounding embankment or embankment foundation, as well as within any earthen barriers, should be monitored and recorded to determine whether hydrostatic pressures are within design limits and whether changes or trends are reasonable. Selection of the type of piezometer and installation location is based on site-specific requirements and the potential for rapid or sudden changes in pore water pressure (as may occur upstream of construction areas). Open standpipe piezometers provide direct measurement of groundwater levels, while vibrating-wire and pneumatic piezometers allow for monitoring of phreatic conditions in fine-grained deposits where rapid changes in pore pressure may be important. A table indicating maximum allowable readings for piezometers should be included with the design report.

5.8.3 Pool Levels

Records for the pool level in the impoundment should be maintained for freeboard monitoring and for determining correlations between piezometric levels and seepage quantities. Pool level can be monitored by installation and reading of staff gauges. When water in nearby mine workings has the potential to affect an impoundment or may indicate the performance of a barrier, the mine pool level should be monitored.

5.8.4 Rainfall Data

A rain gauge installed near the disposal site can provide site-specific precipitation data for correlations with piezometric levels and seepage quantities, and these data may be essential in situations where there is breakthrough potential and where discharges from a mine are related to seepage from an impoundment. Rainfall data should be routinely collected and recorded so that changes in seepage, mine discharge, or water level data can be correlated to rainfall infiltration/runoff.

5.8.5 Deformation or Movement

Where significant embankment settlement can occur or there is a potential for subsidence in the vicinity of an impoundment, movements should be monitored and recorded. Monitoring of the slopes and crest of an impounding embankment should be conducted at regular intervals during both operating and dormant phases for evaluating performance and for demonstrating conformance with flood routing assumptions. When subsidence is a concern, both horizontal and vertical movements should be measured. Movements should also be monitored if evidence of slope displacement is detected. In situations where deformation is occurring, the rate of movement, and especially any acceleration of the rate, provides valuable information for assessing its significance. Methods for monitoring surface deformation include survey monuments and extensometers. Movements below the ground surface can be monitored with inclinometers and extensometers. These types of instruments are discussed in more detail in Chapter 13.

5.9 RECLAMATION, ABANDONMENT AND POST-MINING LAND USE

A coal refuse disposal plan should address reclamation, abandonment and post-mining land use requirements.

General provisions for and plans related to abandonment of a coal refuse embankment are part of the final operational stage of the disposal facility and should address elimination of the impoundment, unless the impoundment is a component of planned post-mining land use. Reclamation should incorporate the following provisions:

- Stockpiles of soil and topsoil for reclamation should be located near the facility on stable ground and within sedimentation controls.
- Reclamation materials should meet the growth medium and nutrient requirements of the vegetation plan. Topsoil amendments and alternatives may be necessary.
- To protect against erosion and sedimentation and potentially negative environmental impacts, surface drainage and infiltration should be controlled.

Elimination of impoundments should address the following:

- Regrading of the impounding embankment and backfilling of the impoundment should be performed in a manner such that proper surface drainage is established and the fine coal refuse is stabilized. Final backfill elevations should facilitate drainage and accommodate settlement of the fine refuse that will occur over time.
- During the final periods of disposal and progressive elimination of the impoundment capacity, the outlet works such as the decant structure or spillway should remain operational until impoundment regrading is complete.
- Decant systems should generally be sealed by grouting.

Post-mining land use will affect the reclamation plan, particularly if existing structures such as the impoundment or ponds are to be retained.

Chapter 6

GEOTECHNICAL EXPLORATION, MATERIAL TESTING, ENGINEERING ANALYSIS AND DESIGN

This chapter addresses important aspects of geotechnical exploration, material testing, engineering analysis and design for coal refuse disposal embankments and impoundments with consideration of past, current and future mining practices; characteristics of foundation, coal refuse, and soil and rock borrow materials; and procedures for material placement and facility construction. Development of a subsurface exploration program, implementation of a field and laboratory testing program, and selection of geotechnical parameters are key elements in the design of safe facilities for coal refuse disposal. The basic design considerations that must be evaluated for both embankments and foundations are seepage, slope stability and settlement. Another important geotechnical consideration is the analysis of soil-structure interaction for buried pipes (conduits or decant pipes) that are installed within an embankment. Specification, field control and verification of geotechnical properties are essential to the construction of coal refuse embankments that are consistent with design assumptions.

From a geotechnical perspective, the following steps are normally followed in the design and construction of a new or modification of an existing refuse embankment:

- Review of available information
- Site selection and optimization
- Field exploration and in-situ sampling and testing
- Laboratory testing
- Development of geotechnical design parameters
- Analyses and design
- Preparation of plans and specifications
- Construction monitoring (quality control and verification of field conditions)
- Instrumentation
- Embankment and system component performance monitoring
- Maintenance

The level of effort and technical scrutiny required during the above steps will vary depending upon the refuse facility intended use, size and hazard-potential classification.

This chapter describes the scope of geotechnical investigations recommended for support of analyses and design of a refuse disposal facility. References for additional information are provided herein. Based upon the technical guidance provided in this chapter and supplemental information available in the cited references, an experienced geotechnical engineer familiar with the refuse disposal process and the design of water-retention embankment structures should be able to design an economical, safe and environmentally acceptable coal refuse disposal facility. Designers should recognize that investigation programs and studies for specific projects can not realistically be standardized and will vary according to site conditions, material properties, embankment geometry, hazard classification and proposed staging scheme.

In addition to refuse disposal embankments, this chapter is also applicable to other types of embankments that are employed at mine sites including fresh water dams and sedimentation or treatment ponds. Other applications and available design guidance are presented in [Section 6.3.6](#).

In the text that follows, many references are made to ASTM International (ASTM) standards. All references to ASTM standards in this chapter can be found in three volumes of *Section Four – Construction* of the ASTM standards, which are published annually. The most current versions of the standards should be used. The applicable volumes and their citations herein are:

- Volume 05.06 – Gaseous Fuels; Coal and Coke (ASTM, 2008a)
- Volume 04.08 – Soil and Rock (I): D 420 – D 5786 (ASTM, 2008b)
- Volume 04.09 – Soil and Rock (II): D 5877 – latest (ASTM, 2008c)
- Volume 04.13 – Geosynthetics (ASTM, 2008d)

Full citations for these volumes are provided in the References section at the end of this Manual.

6.1 GEOTECHNICAL DESIGN PROCEDURES

This section outlines the steps normally required for designing the geotechnical aspects of a coal refuse disposal facility. The geotechnical design of a new refuse disposal facility provides flexibilities that designers should recognize in their planning. These include:

- Ability to determine the optimum location for the facility
- Flexibility in the design of the starter dam and embankment staging
- Ability to coordinate ongoing and future mining with staging in the vicinity of refuse disposal footprints
- Flexibility in designing the internal drainage system and liner system (if required)
- Flexibility in the selection and design of hydraulic structures

Geotechnical design for an expansion of an existing disposal facility typically imposes constraints that designers must recognize in their planning, particularly limited flexibility in planning embankment staging and design of hydraulic structures while maintaining ongoing disposal operations. [Table 6.1](#) presents guidance for the geotechnical design of refuse disposal facilities with reference to applicable sections of this Manual and to supplemental documents.

6.2 GENERAL CONSIDERATIONS

6.2.1 Unique Characteristics of Refuse Disposal Facilities

A typical coal refuse disposal facility has unique characteristics and objectives compared to most other engineered structures. Some of the basic characteristics of coal refuse disposal facilities and their related significance in geotechnical design are identified in [Table 6.2](#).

TABLE 6.1 TYPICAL GEOTECHNICAL DESIGN PROCEDURE FOR COAL REFUSE DISPOSAL FACILITIES⁽¹⁾

Design Considerations	Manual Sections for Reference	Supplemental References
I. Obtain and Review Available Information		
Topographic Maps Geologic Maps Soils Maps Aerial Photographs Local Experience Individual Site Mapping Seismicity Maps Mine Maps	6.4	USBR (1992a)
II. Plan Field Exploration		
What is probable configuration?	6.2, Chapter 3	
What type of hydraulic structures are likely?	Chapters 3, 5, 9	
Where might important embankments and structures be located?	6.2, Chapter 3	
What are significant foundation characteristics?	6.2, 6.3, 6.4, 6.6	
What types of borrow material may be required?	6.2, 6.3	USBR (1992a)
What are probable sources of borrow material?	6.2, 6.3	Sherard et al. (1963)
What types of sampling will be required?	6.4, 6.5	
What types of environmental control measures should be considered?	6.3, Chapters 4, 10	
Is past or present mining in the area being considered?	6.3, Chapter 8	
What changes in the disposal program are likely during the life of the facility?	Chapters 4, 10	
III. Field Exploration		
Surficial Reconnaissance Geophysical Surveys Borings and Sampling Test Pits Visual Classification Field Testing Soils and Water Inventory	6.4	Arman et al. (1997) Hvorslev (1948) Legget (1962) USBR (1998, 1992a)
IV. Laboratory Program		
Natural Materials		
<ul style="list-style-type: none"> • Index Property Tests • Compaction Tests • Hydraulic Conductivity • Consolidation • Shear Strength • Potential Acidity/Neutralization Potential 	6.5	ASTM (2008b,c) Lambe (1951) Bishop and Henkel (1962) USBR (1992a)
Refuse Materials:		
<ul style="list-style-type: none"> • Index Property Tests • Compaction • Hydraulic Conductivity and Consolidation • Shear Strength • Leachate Quality 	6.5	MSHA (2007)

TABLE 6.1 TYPICAL GEOTECHNICAL DESIGN PROCEDURE FOR COAL REFUSE DISPOSAL FACILITIES⁽¹⁾
(Continued)

Design Considerations	Manual Sections for Reference	Supplemental References
V. Design Considerations and Analyses		
Foundation Preparation Seepage Control Static and Seismic Stability Settlement Rock Excavation	Chapters 6, 7, 8	USBR (1987a,1989) Leonards (1962) USACE (1993)
VI. Construction Operations		
Refuse Transport and Placement Foundation Preparation Borrow Materials Appurtenant Facility Construction Materials Selection Quality Control and Field Testing	Chapter 11	USBR (1987a,1989) Church (1981) USBR (1998) Fell et al. (2005)
VII. Instrumentation and Monitoring		
Visual Observations Movements and Displacements Pore-Water Pressures Hydrology and Hydraulics General Maintenance	Chapters 12, 13	USBR (1998) Dunncliff (1993) USACE (1995c)

Note: 1. This table is presented as a guide to qualified geotechnical designers. Each site must be evaluated according to conditions at that site. In some cases, studies beyond those identified in this table may be needed.

6.2.2 Site Conditions

In contrast to site selection for a dam that must be built across a valley to form a reservoir of designated size, site selection for a coal refuse disposal facility is generally flexible because of the variety of embankment types that can be constructed. The principal considerations in the selection of a disposal facility site are typically: (1) the potential disposal capacity of the valley/site, (2) the desired preparation plant processing output, (3) the potential influence of previous mining activities, (4) refuse transportation and placement, (5) construction of site development and drainage structures, and (6) other environmental control and safety factors.

6.2.2.1 Topography

Site terrain slopes are very important in disposal facility site selection because of their impact on storage volume, methods and costs of materials handling, methods and costs of drainage control, and hazard potential.

In areas of rugged and steep terrain, such as southern West Virginia, southwest Virginia, and eastern Kentucky, most disposal facilities will be valley-type embankments. Valley slopes are often too steep for side-hill embankments. Ridge tops are generally difficult to access and are limited in area to support large embankments; however, some ridge-top sites can be used in conjunction with mountain-top surface mining operations. Major valley bottoms are too confining for the construction of large

heaped or diked embankments. Therefore, the typical disposal facility site is generally a small valley selected by considering:

- Potential effects of past or future mining beneath the site
- Proximity to existing preparation plants
- Surface land ownership
- Cost of establishing a materials-handling system suitable for the topography
- Ability to sequence construction to handle the types and volumes of refuse to be disposed
- Potential to discharge storm water through or around the site
- Stability of existing slopes when modified by construction or imposed loads

In areas of less severe topography, such as in southwestern Pennsylvania, the range of potential site location and embankment types is much greater. However, disposal facilities in these areas are frequently located in small valleys because of their capability to accommodate large volumes of refuse without extensive modification of natural topography. Also, the rolling topography often makes construction of ridge, side-hill or heaped embankments practical.

In relatively flat terrain, as found in portions of Illinois and Indiana, refuse disposal in valleys may not be practical, and the refuse disposal facility will generally be of the heaped (Figure 3.12) or diked-pond embankment type (Figure 3.13). These types of disposal facilities present unique problems for fine refuse disposal in slurry form because volume containment by utilizing the natural topography is not possible. When fine refuse slurry is a small percentage of the total refuse, the most economical disposal facility is a diked-pond embankment constructed from coarse refuse.

TABLE 6.2 BASIC CHARACTERISTICS OF COAL REFUSE DISPOSAL AND DESIGN SIGNIFICANCE

Basic Characteristic	Design Significance
The purpose is safe and economical disposal of refuse.	Greater flexibility in choosing location, configuration and sequence of placement.
The total disposal volume of coarse refuse is normally much greater than that required to serve safety requirements.	Embankment zones may allow different placement specifications (e.g., structural zone).
The refuse disposal occurs over many years and may lead to several unforeseen events and constraints not realized at the time of design.	Construction monitoring and quality control may be specified for the critical construction items with periodical monitoring of routine construction.
The geotechnical properties of refuse may not be available during the design (particularly for a new facility), and changes in the material properties are probable during the life of the facility.	For new facilities, geotechnical design parameters may be estimated based on experience and from facilities with similar characteristics (e.g., similar seam properties, mining technique, and cleaning process). The geotechnical design parameters can be verified when actual samples are available and can be re-evaluated if characteristics change.
The refuse being placed can have adverse chemical characteristics that may lead to undesirable environmental conditions or deterioration of construction materials.	Geotechnical and leachate characteristics of the refuse should be evaluated based on experience and/or by laboratory test, and appropriate amendment or containment/protection requirements should be identified.
After completion of disposal operations, the facility will need to be abandoned in a safe, economical and environmentally acceptable manner.	Planning and design must allow for an acceptable abandonment configuration with materials for effective reclamation.

6.2.2.2 Climate/Weather

Due to the small surface area of coal refuse impoundments, wind, rainfall and temperature conditions are generally not major factors in selecting the most appropriate site for a refuse disposal facility for a given mining operation. However, the variation of weather conditions in different regions of the country can significantly affect disposal facility configuration and design requirements.

For example, in the Appalachian coal region, rainfall is relatively uniform and abundant throughout most of the year. Thus, addition of water to coal refuse for controlled placement in an embankment is seldom a major design and cost consideration. A more important criterion in this region may be to assure that work in valley bottoms, or in critical structural portions of the embankment, can be accomplished during the summer months when conditions are driest.

At the other extreme, such as in the semi-arid Rocky Mountains and Western plains, there is a general lack of precipitation for most of the year. In this situation, the designer must evaluate appropriate control measures and associated costs for adding water to refuse to achieve required placement criteria. Also, the precipitation that does occur is often in the form of high intensity thunderstorms, increasing the required capacity of flood control and diversion structures.

Clearly, the planning of otherwise similar disposal facilities will vary according to geographic location. Regardless of the site location, the size of the watershed draining into a disposal area should be minimized unless other design factors justify the cost of major drainage control systems.

Disposal facilities in regions with extended cold winters and significant snowfalls may require special attention to configuration, materials handling and refuse placement. For example, it may be that critical structural portions of an embankment can be constructed most economically during the construction season when drainage and material properties are most easily controlled. Overall efficiency is then accomplished by establishing areas for placement of refuse in non-critical areas during the remainder of the year.

Blowing dust is generally not considered to be a major design problem with coal refuse disposal. However, dust has been a problem with other types of industrial and mining waste disposal, particularly for disposal of fine-particle materials such as combustion waste.

6.2.2.3 Geology and Surficial Soils

Coal refuse disposal facility design is affected by geology and surficial soil conditions as they relate to the following:

- Extent and effects of past or future mining
- Necessary foundation treatment
- Available borrow material
- Type and size of the starter dam
- Effects of refuse disposal on groundwater quality and the effects of groundwater seepage on embankment design
- Stability and hydraulic conductivity of the existing foundation materials under natural and disturbed conditions

Specific design factors that may be affected by geology and surficial soil conditions include:

- Acceptable embankment slopes as related to the shear strength of the underlying foundation materials.

- Limitations on the location and design of the impounding facility posed by active or inactive landslides.
- Seepage cutoffs through pervious foundation soils for embankments that impound water.
- Embankment construction to account for settlement of underlying soft foundation materials.
- Selection of the starter dam configuration and zoning.
- Starter dam and embankment construction rates to keep excess pore-water pressures to within acceptable limits.
- Seals between foundation rock and the impervious zone of an impounding embankment.
- Situations where badly fractured foundation rock must be grouted to control seepage from an impounding embankment.
- Liner and underdrain systems to address protection of groundwater or seepage into the embankment.
- Selection of decanting and other hydraulic structures to control impounded storm runoff.
- Erosion control measures for surface runoff and drainage structures
- Potential liquefaction of embankment and foundation materials in regions subject to moderate or high seismic loading.

The wide variations of geology and surficial soil conditions that may be present make generalized examples of these situations impossible. However, if mining has occurred beneath a disposal facility, it is particularly important to evaluate the effect of existing or potential subsidence on the embankment and the potential for the contents of the reservoir to break through into the mine. If it is determined that subsidence has occurred or that new or continued subsidence may occur, potential detrimental effects on the structural and hydraulic conductivity characteristics of the refuse embankment must be evaluated. The possible effects on groundwater quality due to leachate infiltrations into fractured foundation bedrock, or due to discharge of fine coal refuse into underground mine voids if the overburden collapses, should also be considered. If mining has not occurred at the planned refuse disposal facility site, construction of the disposal facility may limit the extraction of underlying coal reserves, and this cost factor should be considered in the economic evaluation.

Procedures for investigating and analyzing geology and surficial soil conditions are discussed in Section 6.4, and construction aspects of foundation preparation are discussed in Chapter 11. Designers must understand that an optimum disposal facility can only be achieved if general site conditions are well understood prior to the selection of the facility site and configuration. This knowledge will help to prevent unnecessarily conservative designs as well as designs that may be susceptible to increased maintenance or environmental problems.

6.2.2.4 Miscellaneous Site Considerations

Other considerations that may not be directly related to site conditions, but may influence the design and the volume capacity of the facility include:

- Access to public roads
- Availability of utilities
- Future mine developments
- Mine infrastructure (e.g., conveyor belts, access roads and mine entries)

6.2.3 Embankment Materials

The purpose of a coal refuse disposal impoundment is to provide a means for safe and economical disposal of coal refuse. However, due to safety and operational considerations, other materials are required for development of the facility. For example, since coarse coal refuse is generally susceptible to weathering, crushing and degradation, more resistant granular rock is normally needed for construction of drainage zones and for providing erosion protection. Also, at new facilities, disposal of fine coal refuse requires initial construction of a starter embankment or dam for slurry retention and settling when sufficient coarse refuse is unavailable during disposal facility startup. Starter dams are generally constructed with borrow material, unless suitable coarse coal refuse is available on site. The cost of imported borrow materials is much greater than the coarse refuse, so their use should be limited to addressing specific design requirements. Borrow materials can be obtained directly from mine spoils, from processing of mine spoils, or from a suitable area at or near the site. Embankment materials that must be purchased from a commercial quarry and transported to the site are the most costly alternative.

Other examples where site borrow or imported materials may be needed to supplement the refuse include: (1) fine-grained soils for creating an embankment impervious zone when the material available will not adequately limit seepage, (2) cover soils suitable for revegetation, and (3) soil and rock for supplementing embankment construction when coarse refuse is unavailable or inadequate for slurry retention and storm routing.

The most convenient and economical source for borrow material is typically the area that will eventually be covered by refuse. Use of this material will minimize transportation costs and will increase the capacity of the disposal facility, although it can lead to more extensive seepage control and groundwater protection requirements. Another economical source of borrow material is mine spoil with a matrix of soil and rock. To avoid unnecessary double handling and stockpiling and to assure that the required quantities of materials are excavated from the disposal area, careful planning is essential. This precaution is especially important when the borrow material will be used for final cover.

When selecting borrow materials from the disposal area, it is important that removal of the material will not be detrimental to the long-term performance of the facility. For example, if the natural soils form a desirable impermeable boundary between the refuse and underlying rock, borrow activities should be restricted to areas of thickest soil cover in order to leave a continuous layer of soil.

The required characteristics for materials used in the construction of refuse embankments are discussed in [Sections 6.4](#) and [6.6](#); transport and placement procedures are discussed in Chapter 11. The following brief discussion of materials generally available for embankment construction is presented to aid initial planning and design.

6.2.3.1 Coarse Coal Refuse

Non-impounding embankments (“refuse piles”) are commonly constructed entirely with coarse coal refuse. Portions of a non-impounding embankment where supplemental borrow material may be needed include: (1) granular underdrain zones for collecting and discharging groundwater seepage away from the refuse, (2) granular zones for controlling seepage or collecting leachates, (3) cover material for promoting vegetation of the embankment surface, and (4) durable, weather-resistant rock for erosion protection in swales, ditches and channels.

Coarse refuse is typically the predominant material used to construct embankments for impounding fine coal refuse slurry. However, materials for impervious zones, filters, and drainage zones for these structures must have specific characteristics and normally must be obtained from suitable borrow areas or from commercial sources.

A summary of published grain-size, specific-gravity, and strength-testing data for coarse coal refuse samples, including their geographic source, is presented in Table 6.3. While coarse coal refuse is generally a well-graded material, significant variation, particularly with respect to the clay-, silt- and fine-sand-size fraction, has been reported depending on geographic location (which generally relates to geologic conditions) or coal mining or preparation processes. Advances in coal mining and preparation processes over the last 15 years have resulted in a trend toward greater percentages of fines in coarse coal refuse. While recent published data (Hegazy et al., 2004) provide evidence of the increase in fines content of coarse refuse in the northern Appalachian area, resulting in classification as silty, clayey sand with gravel to clayey, silty sand with gravel, other regions typically exhibit lower fines content with corresponding classification as a well-graded to silty gravel. Reported strength data are consistent with soil and rock content and gradation.

TABLE 6.3 COARSE COAL REFUSE CHARACTERIZATION – SUMMARY OF AVERAGE/RANGE OF VALUES

Reference	Location	Grain Size				Specific Gravity G_s (gm/cm ³)	Effective Shear Strength	
		D ₃₀ (mm)	D ₅₀ (mm)	D ₆₀ (mm)	Passing No. 200 Sieve (%)		ϕ' (degrees)	c' (psf)
Almes and Butail (1976)	PA, WV, KY, VA	0.7	2.5	4.5	10	1.8-2.4	33-39	0
McCutcheon (1981)	OH	1.9	4.5	7	7	2.0	36	NR
Saxena et al. (1984)	WV	12	16	22	2	2.6	27-40	0-450
Albuquerque (1994)	VA	3.5	7.5	12	1.5	NR ⁽¹⁾	39	0
Hegazy et al. (2004)	PA	0.35	1.23	2.02	19.8	2.0	34	250
Busch et al. (1974)	WV	0.2-4	1-10	3-20	2-19	1.7-2.3	NR	NR
Backer et al. (1977)	UT, NM	1-6	3-15	6-20	4-15	1.7-2.3	NR	NR
Stewart and Atkins (1983)	Eastern PA (anthracite)	1-8	5-16	7-22	1-7	2.2-2.4	NR	NR
Zeng and Goble (2008)	Appalachian region	2	6	9	12	2.5	NR	NR

Note: 1. NR = not reported

Compaction, equipment traffic and weathering cause degradation of coarse coal refuse. Larger pieces of shale will generally crumble to small particles after exposure to the atmosphere for only a short period of time. Thus, the percentage of fines in “aged” refuse can be noticeably greater than in fresh or recently placed coarse coal refuse. Based upon sieve analyses results for fresh and compacted samples, Hegazy et al. (2004) have reported an average increase of fines of about 4 percent due to compaction alone.

6.2.3.2 Fine Coal Refuse

Fine coal refuse, when very wet or in slurry form, is not generally suitable for construction of the structural portion of an embankment. However, fine refuse can be used as the foundation for portions of an embankment when it has had sufficient time to settle and excess pore-water pressures have adequately dissipated. Designers are cautioned that embankments that have fine refuse as a foundation material require comprehensive evaluations and analyses of the following:

- Construction schedule
- Geotechnical properties and strength
- Settlement and seepage properties
- Placement procedures
- Measures for equipment operator safety
- Seismicity, dynamic properties and potential for associated strength loss

Fine coal refuse is the product of extracting, crushing, and cleaning raw coal. The fine coal refuse slurry is typically pumped upstream of an impounding embankment. The coarser material settles out more quickly nearer the discharge location (customarily near the upstream slope of the embankment), forming a fines delta or beach. The finer materials migrate throughout the impoundment, because they take longer to settle. Thus, samples collected from or near the delta are predominantly sand and silt-sized particles, whereas samples collected away from the delta are predominantly silt and clay-sized particles. A summary of published geotechnical data (average and range of values) for fine coal refuse samples, including their source location, is presented in Table 6.4. This table is based on samples collected from slurry impoundments and may reflect the effect of segregation that occurs with settling and deposition. Variations in grain size and plasticity occur due to rock strata, coal extraction and processing, and impoundment depositional characteristics, and thus properties may vary from those reported in Table 6.4. Site-specific testing has characterized fine refuse as plastic clay/silt, low plasticity sandy silt or clay, or low to non-plastic silty/clayey sand typically exhibiting a lower specific gravity (and dry density) and lower peak shear strength than coarse coal refuse.

The grain-size distribution of thickened and dewatered fine coal refuse can be anticipated to be similar to the averages provided in Table 6.4, as this material does not significantly segregate with placement.

6.2.3.3 Combined Refuse

Some coal preparation plants produce combined refuse that does not require impoundments for disposal of fine refuse. At these preparation plants, partially dewatered fine refuse filter cake is produced in addition to coarse refuse. These materials are normally combined, transported and disposed in a non-impounding disposal facility.

Properties of this combined refuse depend on the initial moisture content of the filter cake, the ratio of fine to coarse refuse, and the particle size and moisture content of the coarse refuse. Often, these properties make it difficult to place combined refuse in a controlled manner, and they may limit its potential for use within the structural portion of an embankment. Combined refuse is sometimes mixed with combustion ash for construction of a homogeneous embankment or, in some cases, a zoned embankment (for construction of the downstream structural shell). Table 6.5 presents published geotechnical test data for combined coal refuse from several locations for a range of fines content. The strength data are based on remolded samples compacted to 95 percent standard Proctor maximum dry density, which can be difficult to achieve if the fine portion of the refuse has a high water content.

TABLE 6.4 FINE COAL REFUSE CHARACTERIZATION – SUMMARY OF AVERAGE/RANGE OF VALUES

Reference	Location	Grain Size		Atterberg Limits			Specific Gravity G_s (gm/cm ³)	Effective Shear Strength	
		Passing No. 40 Sieve (%)	Passing No. 200 Sieve (%)	LL (%)	PL (%)	PI (%)		ϕ' (degrees)	c' (psf)
Almes and Butail (1976)	PA, WV, KY, VA	64-100	36-47	20-40	NR ⁽¹⁾	<10	1.55-1.65	29-34	0
McCutcheon (1983)	OH	81	46	29	22	7	1.85	36	0
Qiu and Sego (2001)	Western Canada	90	66	40	24	16	1.94	32	200
Hegazy et al. (2004)	PA	65-100	58	31	20	11	1.52	33	230
Genes et al. (2000)	WV	NR	16-90	NR	NR	<12	1.44-2.37	23-36	0
Cowherd and Corda (1998)	NR	NR	24-91	23-39	NR	0-9	1.4-2.1	NR	NR
Huang et al. (1987)	KY, OH, PA, TN, VA, WV	NR	27-95	22-44	NR	0-12	1.52-2.14	NR	NR
Busch et al. (1974,1975)	WV	50-98	10-60	34-51	NR	0-13	1.45-2.07	NR	NR
Backer et al. (1977)	UT, NM	60-100	16-98	NR	NR	NR	1.33-2.07	NR	NR
Ullrich et al. (1991)	KY, TN, OH	45-95	25-85	31-44	NR	0-31	1.8-2.5	NR	NR
Zeng and Goble (2008)	Appalachian Region	75-85	40-62	27-36	21-26	3-11	2.02-2.16	NR	NR

Note: 1. NR = not reported

6.2.3.4 Borrow Materials

Borrow materials are those soil and rock materials used in an embankment to meet specific design criteria. Borrow materials are used principally for:

- Starter dam construction
- Filters and drainage zones
- Impervious zones
- Sedimentation pond embankments
- Erosion protection
- Buttresses
- Reclamation cover

For economical designs, most borrow materials are obtained at the site or from suitable nearby mine spoil. Materials for filters, drains, and erosion protection are typically obtained from commercial sources.

TABLE 6.5 COMBINED COAL REFUSE CHARACTERIZATION

Location	Grain Size		Specific Gravity G_s (gm/cm ³)	Total Shear Strength	
	Passing No. 4 Sieve (percent)	Passing No. 200 Sieve (percent)		ϕ (degrees)	c (psf)
Pennsylvania	25-60	7-26	1.9-2.0	26-28	NR
Ohio	25-58	5-11	1.8	36-38	NR
West Virginia	18-58	4-12	2.1	32	NR
Colorado	18-54	3-18	1.8-1.9	33-38	NR

(STEWART AND ATKINS, 1982)

The available mine spoil and borrow materials in most coal mining regions of the U.S. consist either of bedrock or soils derived from bedrock. Typical bedrocks include: (1) soft shales, siltstones and claystones that weather rapidly when excavated and break down to a soil when compacted, (2) harder limestones that usually resist weathering except when exposed to acidic waters from leachates passing through pyritic coal and coal refuse, and (3) hard sandstones that often are resistant to natural weathering and attack from leachates. The soil components are typically present as alluvial deposits in valley bottoms, colluvial deposits that have accumulated toward the base of slopes, residual soils derived from surface weathering of the rock, or partially decomposed weathered rock.

Soft rock is normally suitable for the downstream portion of starter dams not critical to seepage control. The initial particle size of soft rock may prevent its use for constructing impervious zones, and its weathering characteristics usually prevent its use for drainage or erosion protection purposes. When soft rock is used, its design strength characteristics should be based on predicted future compacted or weathered condition, often as a soil. The use of limestone should usually be avoided due to its susceptibility to deterioration from leachates. Limestone can be used in situations where: (1) acidic conditions will not occur, (2) it is arranged within an embankment in a manner that assures separation from acidic leachates, or (3) when it is used in a manner that does not depend upon continued integrity as a granular material. In most coal mining regions, hard sandstone is the best material for erosion protection, filters and drainage zones.

Mine spoil tends to be highly variable in soil and rock content and particle size, and processing may be necessary. This can be accomplished by segregating over-sized fractions or fines, which can be used for other project applications. Sometimes mine spoil can be used for construction without processing of the materials (e.g., in a zoned embankment).

Recent alluvial and older river terrace deposits can vary from relatively clean sands and gravels to "dirty" soils with high contents of fine-grained soils and organic material. Material from clean sand and gravel deposits may be suitable for constructing filter or drainage zones in an embankment, but only after field investigation has determined the quantity of clean material available and laboratory testing has verified the suitability of the grain-size distribution and mineral composition for the intended purposes. Otherwise, alluvial soils typically are not desirable for use in a coal refuse disposal embankment because of the expense associated with excavation and preparation.

Colluvial soils generally consist of a combination of soils derived from fine- and coarse-grained rocks and vary from clays to primarily sandy material. Fine-grained colluvial soils may be suitable for constructing an impervious zone, while all types of colluvium are normally suitable for use as structural

components for stability or as cover material to support vegetation. Because they generally have a wide grain-size distribution, colluvial soils normally are not suitable for either filter or drainage zones in an embankment.

Residual soils derived from soft rocks (e.g., shale) are normally fine-grained and suitable for either an impervious zone or the structural portion of an embankment. When available in thick deposits, residual soils can generally be excavated economically. Soils derived from sandstone are too coarse for use in impervious zones, but may be suitable for structural fill or use in drainage zones.

For any borrow material, the deposit must be explored to verify that it is available in adequate quantities to meet the design requirements of the disposal facility. This must be followed by laboratory testing to evaluate the suitability of the borrow materials/mine spoils for embankment construction. Although practically any inorganic, insoluble soil can be incorporated into an embankment when modern compaction equipment and control standards are employed, the following problems may arise:

- Fine-grained soils may have insufficient shear strength or excessive compressibility.
- Clays of medium to high plasticity may expand if placed under low confining pressures and/or at low moisture contents.
- Plastic soils with high natural moisture content may be difficult to adjust for proper moisture for compaction.
- Dispersive clays are not suitable for use in dam embankments.
- Silts may have insufficient erosion resistance.
- Stratified soils may require extensive mixing of borrow material.

Table 6.6 shows a correlation between soil classification and the engineering and design properties of compacted soils (DOD, 2005). This table can be used for evaluation of borrow materials and preliminary design of starter dams. Table 6.7 provides a correlation between soil classification and the relative desirability of soil as compacted fill material for various types of starter embankments. Table 6.8 (Sherard et al., 1963) illustrates a correlation between soil classification and engineering properties related to embankment design and constructability.

6.2.3.5 Coal Combustion Products from Power Plants

The combustion of coal at fossil fuel power plants produces fly ash and bottom ash as residual waste products. Two other products of coal combustion air pollution control technology are fluidized-bed combustion (FBC) waste and flue-gas-desulfurization (FGD) sludge. While no detailed assessment of these and other wastes from the power plants is provided in this Manual, embankments at some refuse disposal sites have been constructed by integrating power plant waste products with coal refuse. The important issues that designers should consider if these waste products are disposed at coal refuse facilities are discussed in this section.

Power plant wastes have certain properties that can be very beneficial if these materials are judiciously integrated at coal refuse disposal sites. The economic viability of disposing dissimilar refuse materials can be especially beneficial when the mining operation is near the coal burning plant. With this in view, a brief description of the engineering properties of power plant waste materials is provided in this section. For more detailed discussion and design considerations, the designer should refer to the Electric Power Research Institute (EPRI) Coal Ash Disposal Manual (DiGioia et al., 1995) and other references such as McLaren and DiGioia (1987), DiGioia and Gray (1979), Gray and Lin (1972). Additionally, research has been published (Daniel et al., 2002) on the material properties of mixtures of fly ash and coal refuse in southwest Virginia. A thorough review of the overall environmental implications of fly ash use is provided in Carlson and Adriano (1993). The USEPA (2000) performed a

TABLE 6.6 CORRELATION BETWEEN USCS CLASSIFICATION AND PROPERTIES OF COMPACTED SOILS

Group Symbol	Soil Type	Range of Max. Dry Weight (pcf)	Range of Optimum Moisture (%)	Typical Value of Compression		Typical Strength Characteristics				Typical Hyd. Cond. (ft/min)	Range of CBR Value	Range of Subgrade Modulus k (lbs/in ³)
				1.4 tsf = 20 psi (% of original height)	3.6 tsf = 50 psi (% of original height)	Compacted Cohesion (psf)	Saturated Cohesion (psf)	ϕ (deg)	$\tan \phi$			
GW	Well graded clean gravels, gravel-sand mixtures	125-135	11-8	0.3	0.6	0	0	>38	>0.79	5×10^2	40-80	300-500
GP	Poorly-graded clean gravels, gravel-sand mix	115-125	14-11	0.4	0.9	0	0	>37	>0.74	10^{-1}	30-60	250-400
GM	Silty gravels, poorly-graded gravel-sand mix	120-135	12-8	0.5	1.1	-	-	>34	>0.67	$>10^{-6}$	20-60	100-400
GC	Clayey gravels, poorly graded gravel-sand-clay	115-130	14-9	0.7	1.6	-	-	>31	>0.60	$>10^{-7}$	20-40	100-300
SW	Well-graded clean sands, gravelly sands	110-130	16-9	0.6	1.2	0	0	38	0.79	$>10^{-3}$	20-40	200-300
SP	Poorly-graded clean sands, sand-gravel mix	100-120	21-12	0.8	1.4	0	0	37	0.74	$>10^{-3}$	10-40	200-300
SM	Silty sands, poorly-graded sand-silt mix	110-125	16-11	0.8	1.6	1050	420	34	0.67	5×10^5	10-40	100-300
SM-SC	Sand-silt-clay mix with slightly plastic fines	110-130	15-11	0.8	1.4	1050	300	33	0.66	2×10^6	5-30	100-300
SC	Clayey sands, poorly graded sand-clay mix	105-125	19-11	1.1	2.2	1550	230	31	0.60	5×10^7	5-20	100-300
ML	Inorganic silts and clayey silts	95-120	24-12	0.9	1.7	1400	190	32	0.62	$>10^5$	≤ 15	100-200
ML-CL	Mixture of inorganic silt and clay	100-120	22-12	1.0	2.2	1350	460	32	0.62	5×10^7	-	-
CL	Inorganic clays of low to medium plasticity	95-120	24-12	1.3	2.5	1800	270	28	0.54	$>10^7$	≤ 15	50-200
OL	Organic silts and silt-clays, low plasticity	80-100	33-21	-	-	-	-	-	-	-	≤ 5	50-100
MH	Inorganic clayey silts, elastic silts	70-95	40-24	2.0	3.8	1500	420	25	0.47	5×10^7	≤ 10	50-100
CH	Inorganic clays of high plasticity	75-105	36-19	2.6	3.9	2150	230	19	0.35	$>10^7$	≤ 15	50-150
OH	Organic clays and silty clays	65-100	45-21	-	-	-	-	-	-	-	≤ 5	25-100

- Note:
1. All properties are for condition of "Standard Proctor" maximum density, except values of k and CBR which are for "Modified Proctor" maximum density.
 2. Typical strength characteristics are for effective strength envelopes and are obtained from USBR data.
 3. Compression values are for vertical loading with complete lateral confinement.
 4. (-) indicates insufficient data available for an estimate.

(DOD, 2005)

TABLE 6.7 CORRELATION BETWEEN USCS CLASSIFICATION AND RELATIVE DESIRABILITY OF SOILS AS COMPACTED FILL

Group Symbol	Soil Type	Relative Desirability for Various Uses (1 is most desirable. 14 is least desirable)									
		Rolled Earth Fill Dams			Lining			Foundation			
		Homogenous Embankment	Core	Shell	Erosion Resistance	Compacted Earth Lining	Roadway Surfacing	Seepage Important	Seepage Not Important		
GW	Well graded clean gravels, gravel-sand mixtures	-	-	1	1	-	3	-	-	1	
GP	Poorly-graded clean gravels, gravel-sand mix	-	-	2	2	-	-	-	-	3	
GM	Silty gravels, poorly-graded gravel-sand mix	2	4	-	4	4	5	1	4		
GC	Clayey gravels, poorly graded gravel-sand-clay	1	1	-	3	1	1	2	6		
SW	Well graded clean sands, gravelly sands	-	-	3, if gravelly	6	-	4	-	2		
SP	Poorly graded clean sands, sand-gravel mix	-	-	4, if gravelly	7, if gravelly	-	-	-	5		
SM	Silty sands, poorly graded sand-silt mix	4	5	-	8, if gravelly	5, erosion critical	6	3	7		
SC	Clayey sands, poorly graded sand-clay mix	3	2	-	5	2	2	4	8		
ML	Inorganic silts and clayey silts	6	6	-	-	6, erosion critical	-	6	9		
CL	Inorganic clays of low to medium plasticity	5	3	-	9	3	7	5	10		
OL	Organic silts and silt-clays, low plasticity	8	8	-	-	7, erosion critical	-	7	11		
MH	Inorganic clayey silts, elastic silts	9	9	-	-	-	-	8	12		
CH	Inorganic clays of high plasticity	7	7	-	10	8, vol.-change critical	-	9	13		
OH	Organic clays and silty clays	10	10	-	-	-	-	10	14		

(DOD, 2005)

detailed review of the use of coal combustion products in mining environments that supported their classification as residual waste, although they recommended continued study of disposal in deep mines and in mine backfill situations where the materials may contact groundwater.

Fly ash is a fine, silt-sized material usually ranging in diameter from 0.5 to 100 microns and consisting largely of spherical, sometimes hollow, glassy particles. Bottom ash consists of primarily coarser material with heavier particles than fly ash. It is generally angular with a porous surface. For fly ash, hydraulic conductivities have been reported in the range of 10^{-7} to 10^{-4} cm/sec and for bottom ash in the range of 10^{-3} to 10^{-1} cm/sec (DiGioia et al., 1995). Depending on the actual material, fine-grained fly ash and coarse-grained bottom ash can be used as an "impervious liner" and drainage filter, respectively, in conjunction with coarse coal refuse and other borrow materials. If fly ash is enriched with nitrogen compounds, it can sometimes be used as a supplement for vegetation growth.

There are two general types of fly ash as defined by ASTM. Class F fly ash contains less than 20 percent calcium oxide and is produced by burning bituminous or anthracite coal. Class C fly ash is produced by burning subbituminous coal or lignite. Both have pozzolanic properties, but Class F fly ash is not appreciably self-cementing. Because of the geographical distribution of coal types, Class F fly ash is principally produced in the eastern U.S., while most Class C fly ash is produced in the western U.S. Class C fly ash is self-cementing due to presence of lime and other chemical compounds. However, much of the fly ash returned to Appalachian mines does not meet either Class C or F criteria (Daniels et al., 2002).

TABLE 6.8 APPROXIMATE CORRELATION BETWEEN ENGINEERING PROPERTIES AND SOIL CLASSIFICATION GROUPS

USCS Group Symbol	Relative Hydraulic Conductivity	Probable Range of k (ft/yr)	Relative Piping Resistance	Relative Shear Strength	Relative Workability ⁽¹⁾
GW	Pervious	1,000 – 100,000	High	Very High	Very Good
GP	Pervious to Very Pervious	5,000 – 10,000,000	High to Medium	High	Very Good
GM	Semi-pervious	0.1 – 100	High to Medium	High	Very Good
GC	Impervious	0.01 – 10	Very High	High	Very Good
SW	Pervious	500 – 50,000	High to Medium	Very High	Very Good
SP	Pervious to Semi-pervious	50 – 500,000	Low to Very Low	High	Good to Fair
SM	Semi-pervious to Impervious	0.1 – 500	Medium to Low	High	Good to Fair
SC	Impervious	0.01 – 50	High	High to Medium	Good to Fair
ML	Impervious	0.01 – 50	Low to Very Low	Medium to Low	Fair to Very Poor
CL	Impervious	0.01 – 1	High	Medium	Good to Fair
OL	Impervious	0.01 – 10	Medium	Low	Fair to Poor
MH	Very Impervious	0.001 – 0.1	Medium to High	Low	Poor to Very Poor
CH	Very Impervious	0.0001 – 0.01	Very High	Low to Medium	Very Poor

Note: 1. Relative workability = ease of moisture-density control.

(ADAPTED FROM SHERARD ET AL., 1963)

Power plants may also generate combustion waste from FBC systems and SO₂ scrubbers by utilizing limestone. FBC waste may be pozzolanic or cementitious.

The physical and engineering properties of coal ash that could be of importance when it is used in combination with coal refuse disposal are grain size, specific gravity, density, optimum moisture content, hydraulic conductivity, shear strength, and compressibility.

Tables 6.9 and 6.10 show summaries of particle-size testing results for Class F and Class C fly ash, respectively.

TABLE 6.9 CLASS F FLY ASH

Gradation Property	Number of Samples	Mean Value (mm)	Standard Deviation (mm)	Coefficient of Variation
D ₈₅	84	0.079	0.063	0.800
D ₅₀	84	0.023	0.015	0.669
D ₁₅	84	0.0075	0.0048	0.648

(MCLAREN AND DIGIOIA, 1987)

TABLE 6.10 CLASS C FLY ASH

Gradation Property	Number of Samples	Mean Value (mm)	Standard Deviation (mm)	Coefficient of Variation
D ₈₅	17	0.063	0.020	0.317
D ₅₀	17	0.022	0.011	0.500
D ₁₅	17	0.0084	0.0082	0.976

(McCLAREN AND DIGIOIA, 1987)

A review of available data (McLaren and DiGioia, 1987) shows that fly ash is a relatively uniform, silt-sized material with a specific gravity slightly lower than most natural soils. Compaction of fly ash is moisture dependent, but the range of optimum moisture contents is greater than that of natural silts and silty clays. The maximum dry and wet densities of compacted fly ash are somewhat less than typical values for natural soils, which makes fly ash useful as a light-weight structural fill.

Of importance when fly ash is used in structural zones of a disposal facility is shear strength. The effective angle of internal friction of fly ash and FBC combustion waste varies with the degree of compaction, but generally ranges from 25 to 40 degrees. Class F fly ash is non-cohesive, and while it may appear to be cohesive when partially saturated, this effect is completely lost when the material is either dried or saturated. In contrast, Class C fly ash can develop considerable cohesive shear strength due to cementitious reactions. This cohesion is the dominant factor in the shear strength of Class C fly ash. Similar to fly ash, the shear strength of bottom ash varies with the degree of compaction. The effective angle of friction for bottom ash in a loose state can vary from 38 to 42.5 degrees, with an average of about 41 degrees. The shear strength of SO₂ sludge varies significantly with the solids content and the amount of stabilizing agent added. The strength of a stabilized sludge is comparable to dense sand and gravel, while the strength of unstabilized sludge is similar to that of loose sand. The angle of friction for stabilized sludge ranges from 38 to 51 degrees depending on the solids content and amount of additives. The angle of friction ranges from 20 to 30 degrees for unstabilized sludge.

Research into the beneficial reuse of fly ash mixed with coarse coal refuse in southwest Virginia was performed by Daniels et al. (2002). Table 6.11 shows variations of maximum compacted dry density, shear strength and hydraulic conductivity reported by them for mixtures of fly ash and coal refuse.

TABLE 6.11 FLY ASH/COAL REFUSE MIXTURE PROPERTIES

Fly Ash Mix Ratio (%)	Maximum Dry Density γ_{dmax} (lb/ft ³)	Effective Angle of Internal Friction ϕ' (degrees)	Effective Cohesion c' (lb/ft ²)	Hydraulic Conductivity k (cm/sec)
0	125	39	0	2.86×10^{-3}
8	123	37.7	0	1.01×10^{-3}
16	120	37	0	2.56×10^{-4}
24	119	37	0	1.71×10^{-4}
32	117	37	0	7.88×10^{-5}
100	85	37	0	5.78×10^{-5}

(DANIELS ET AL., 2002)

Research conducted on coal refuse and Type F fly ash from southern Illinois (Kumar et al., 2001) indicated an increase in strength for mixtures containing up to 15 percent ash. There was a tendency for strength to decrease for mixtures with a higher percentage of ash.

Mixing procedures to blend fly ash with refuse material should be developed based on the strength or stabilization requirements for the embankment. In many cases, the primary beneficial use is associated with moisture control, and for this usage blending with spreading equipment on the embankment surface is acceptable. Where enhancement of the strength of the refuse material is a requirement, or in cases where fly ash amendments are introduced to control acid generation, greater effort to mix or blend the materials may be required or beneficial. Additional discussion concerning blending of amendments is presented in [Section 11.5.6](#).

6.2.4 Scheduling

The procedure for scheduling construction of a disposal facility embankment differs from that used for most other types of constructed embankments for several reasons:

- Refuse disposal occurs continually over many years.
- Disposal must occur on a year-round basis, regardless of weather conditions.
- The rate of refuse disposal is not only determined by the needs of embankment construction, but also by the rate of mining, the quality of the seam, market changes, and scheduled and unscheduled work interruptions.

The many variables affecting refuse disposal scheduling limit the ability to provide a detailed flow chart that accounts for all construction events that could occur during the operational period of a disposal facility. However, the following are questions to be answered in developing the design and establishing a general construction schedule for existing and new disposal facilities:

- What is the expected operational period of the disposal facility?
- What volumes of coarse, fine and combined refuse are anticipated from the prepara-

tion plant on an annual basis, and are there reasons to believe that the relative proportions may change?

- What types of borrow material are available, and must they be developed prior to covering the borrow site with refuse?
- What embankment configurations would enable critical sections to be constructed from available materials during periods of the year most conducive to controlled construction?
- What measures to address potential environmental impacts and protection of surface and groundwater will be required?
- Should hydraulic structures (e.g., spillways, decants, diversion systems) be constructed in stages corresponding to disposal rates?
- Can soil and rock materials excavated for hydraulic structures be used as borrow for embankment construction?
- What measures will be required to economically abandon the disposal facility at the end of its expected operational period?
- If for some reason the disposal facility must be abandoned earlier than expected, can that abandonment be reasonably accomplished?
- Will the disposal rate allow portions of the embankment to be completed in stages so that exposed refuse and eventual abandonment costs are minimized?
- If the rate of refuse production or the operational period of the disposal facility is extended beyond initial projections, can the facility be reasonably expanded?
- Will the timing of future surface or underground mining in the vicinity of the facility impact the design?

The designer must recognize that these schedule-related questions may not address all of the potential issues. However, it is prudent to consider each of the above questions when designing a coal refuse disposal facility.

6.3 DESIGN CONSIDERATIONS

This section presents the basic design considerations for coal refuse embankments and earthen dams. Embankments with and without impoundments are considered separately for two reasons. First, an impounding embankment generally has a greater hazard potential because the impounded water can cause damage for a substantial distance downstream from the disposal facility in the event of a failure. Second, impounded water can contribute directly to a failure if the embankment is improperly designed and/or constructed.

The examples discussed in this section are based on the assumption that coarse refuse is the major structural component of embankments for disposal of coarse and fine coal refuse. Mine spoil, soil and rock borrow materials, which are obtainable at most disposal facility sites, could also be used for the starter dam and in the structural portions of the embankment. The designer should refer to Sherard, et al. (1963) and USBR (1992a; 1998) for additional discussion of design principles for dams and embankments composed primarily of soil and rock materials.

6.3.1 Impounding Embankments

A coal refuse impounding embankment is generally designed based upon the same principles as earthen dams, with the exception that refuse materials are used to the maximum extent possible. Two major aspects of coal refuse impounding embankment construction are: (1) the starter dam for initial disposal of fine refuse and (2) the embankment raising methodology used for long-term refuse disposal. The starter dam is typically constructed with borrow materials, while subsequent crest raisings generally utilize coarse coal refuse.

The borrow material available at a site may range from fine to coarse soils to coarse coal refuse, or rocks and soil from mine spoils and highwall cuttings. For economy, suitable materials at or near the disposal site should be used for starter dam construction. Depending on the type of material available at the site, the following types of starter dam may be designed:

- Homogeneous Embankment
- Zoned Embankment

A homogeneous embankment is generally constructed in situations where the borrow materials vary little in hydraulic conductivity or soil type. A zoned embankment is constructed where two or more types of materials are available for embankment construction. Rockfill, when large quantities of rocks are available from the mine spoil or from spillway construction, can also be used as the stability portion of a zoned embankment.

The principal geotechnical considerations in designing an impounding embankment are:

- Seepage control – internal drainage system, impervious zone, and foundation treatment
- Slope and foundation stability – static slope stability, end-of-construction stability, seismic slope stability and deformation, sloughing and erosion
- Drainage structures – principal and emergency spillways, conduits and surface drainage structures
- Underground mine workings – stability, subsidence and breakthrough potential, sealing of mine openings and boreholes, and potential infiltration into underground mine workings

For earth dams, foundation support, stability and seepage control are important design considerations. Geologic and geotechnical investigations should be performed to identify potentially unstable soils that are incapable of sustaining embankment loadings or susceptible to adverse impacts from seepage. Slope failure and piping (internal erosion) are the most common types of embankment failure associated with seepage. In addition to embankment slope and material strength and unit weight, the stability of an embankment is a function of the depth of the saturation level (seepage phreatic surface) below the embankment face, regardless of the volume of seepage through the embankment. If the phreatic surface rises above the level assumed in the design, embankment stability can decrease to the point where failure occurs. Piping is a process in which particles are carried out of an embankment with seepage, creating voids. This can lead to failure as the voids progressively extend farther back into the embankment as more material is removed and more concentrated seepage flow occurs. Installation of an internal drainage system within the embankment is specifically intended to address seepage-type failures and is fundamental to the selection of the embankment configuration. The subsequent discussions of basic embankment types repeatedly emphasize the importance of seepage control. Cedergren (1989) is an important reference for analyzing seepage conditions in embankments and foundations.

In addition to controlling seepage for embankment stabilization, liner systems may also be needed for mitigation of potential environmental impacts to the groundwater and surface water. Impervious liners composed of fine-grained borrow materials, geomembranes or geosynthetic clay liners can be a critical component of disposal facility design.

Uncontrolled seepage into underground mine workings can affect embankment safety. If the water pressure in an impoundment has the potential for breaking through the overburden into abandoned entries or through zones of soft, weathered rock, the rapid release of water or slurry into a mine could

trap mine personnel and equipment and lead to undesirable environmental conditions. Such a situation must be prevented. Even in abandoned workings, the resulting water flow may endanger the population downstream of uncontrolled mine discharge points and cause undesirable environmental conditions. Guidance related to evaluation of breakthrough potential is presented in Section 8.5.

Analysis of seepage, slope stability and structure foundations is generally performed in detail only after the embankment configuration has been selected and the subsurface exploration and laboratory testing programs have been completed. These analyses are introduced in this section and are discussed in more detail in Section 6.6.

6.3.1.1 Homogeneous Embankments

A homogeneous embankment is constructed of only one material; however, to control seepage and saturation of the embankment, a granular internal drain is typically incorporated into the cross section. Homogeneous embankments constructed for coal refuse sites with various types of internal drains are illustrated in Figure 6.1. In all cases, the purpose of the drain is: (1) to maintain stability by keeping the phreatic surface low and (2) to control seepage as it leaves the embankment to minimize the potential for piping. The drainage system may consist of one or more filter zones of intermediate grain-size material to mitigate potential conveyance of embankment material into the collection zone. Selection of the relative gradations of adjacent zones of material and the use of geotextiles to prevent finer material from piping into a coarser downstream zone is discussed in Section 6.6.2. If possible, drainage material should be selected to act as both the filter and the collection zone to avoid the higher costs and more difficult construction associated with placing multiple layers. Selection of the type of internal drainage system is normally based upon the fine refuse and flood pool levels, embankment configuration, and material characteristics, including anisotropy. Table 6.12 summarizes the advantages and disadvantages of the internal drains that are illustrated in Figure 6.1.

When layers of coal refuse are placed during refuse embankment construction, the top surface is often broken into smaller-grained, less-permeable material by the movement of equipment and the effects of weathering. The materials beneath the top surface retain their original grain-size distribution and greater hydraulic conductivity. As a result, anisotropic conditions can develop, leading to an embankment hydraulic conductivity that is greater in the horizontal direction than in the vertical direction. Thus, the effectiveness of a horizontal drainage blanket or toe drain is reduced if the anisotropy is large and the height of the embankment is significant. A chimney drain, or other types of drains that intercept horizontal seepage planes, may be more effective. Section 6.6.2 presents guidance for seepage analyses for the design of internal drains, including the determination of drain dimensions.

At many coarse refuse embankment dams, the fine coal refuse deposited in the impoundment, creates a "delta" or "beach" on the upstream slope that typically restricts seepage, provided that the normal pool is maintained upstream of the delta. Economies in internal drain construction can be achieved by evaluating the hydraulic conductivity characteristics of the fine refuse material, as well as available borrow material, and using zoned embankment design. For homogeneous embankment dams used for fresh water supply, some savings can also be gained by using outlet drains for discharging the water from the base of a chimney drain, which will eliminate the need for a granular blanket extending beneath the entire downstream portion of the embankment. This alternative is illustrated in Figure 6.1d.

6.3.1.2 Zoned Embankments

Coarse coal refuse and mine spoil are generally not sufficiently fine grained to keep seepage at a low level. If the design of an embankment requires that seepage be minimized or it is desired to lower the saturation level in the downstream portion of the embankment, a less pervious zone within the

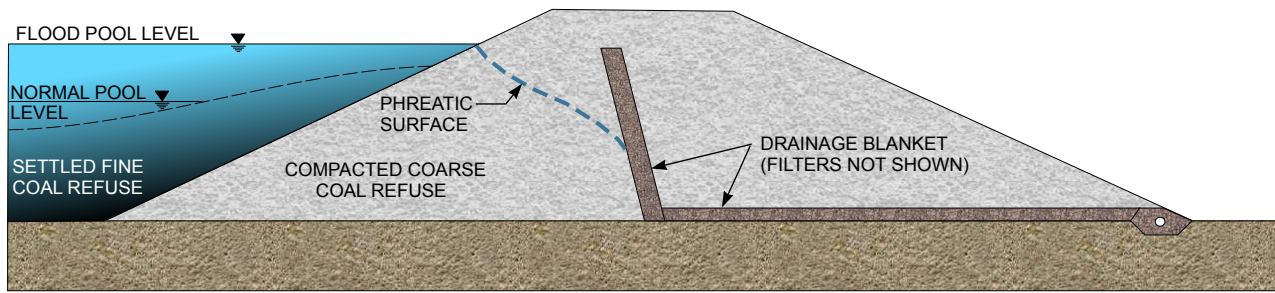

6.1a VERTICAL OR STEEPLY SLOPING CHIMNEY DRAIN

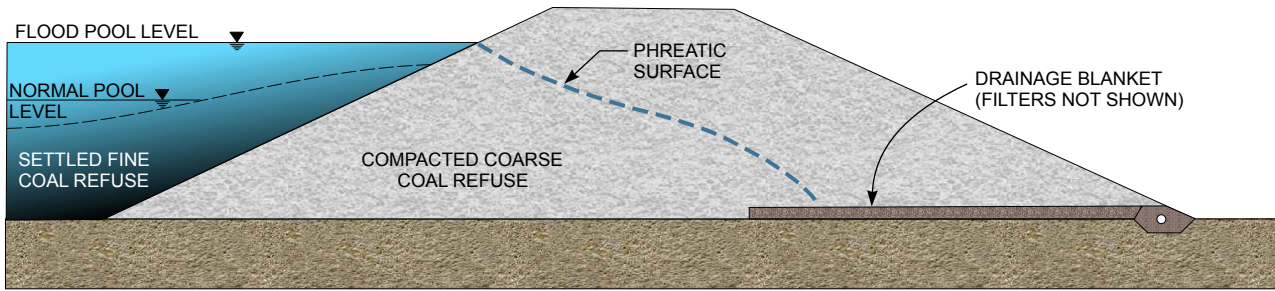

6.1b HORIZONTAL BLANKET DRAIN

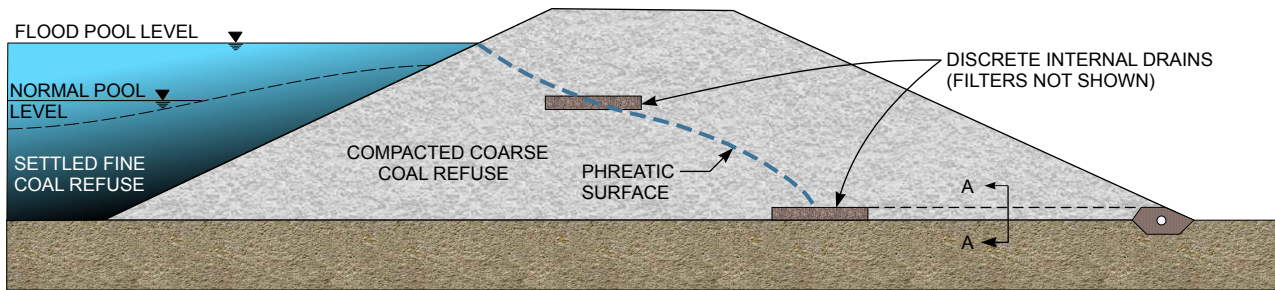

6.1c DISCRETE INTERNAL DRAIN

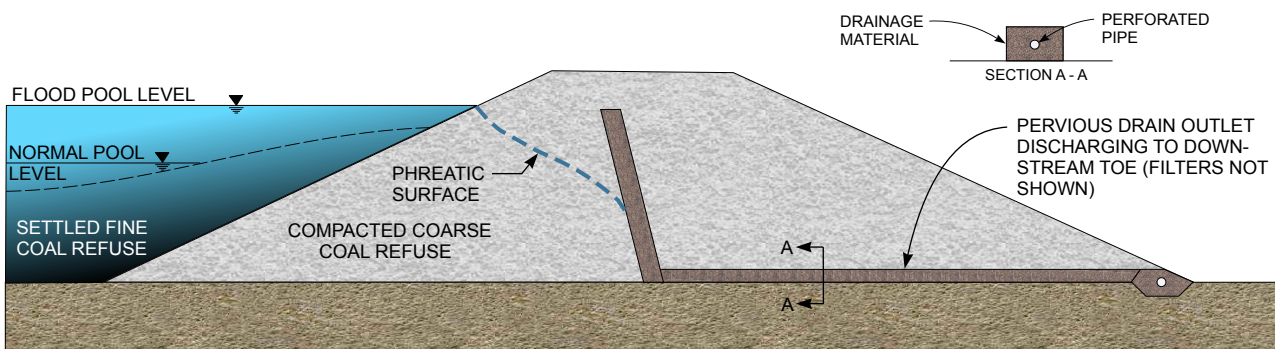

6.1d CHIMNEY DRAIN WITH OUTLET DRAIN EXITS

FIGURE 6.1 DRAIN CONFIGURATIONS FOR HOMOGENEOUS EMBANKMENTS WITH IMPOUNDMENTS

TABLE 6.12 ADVANTAGES AND DISADVANTAGES OF INTERNAL DRAIN TYPES

Internal Drain Type	Figure No.	Advantage(s)	Disadvantage(s)
Steeply Sloping Chimney Drain	6.1a	Positive seepage interception and collection system	Expensive and difficult to construct; requires careful planning and stringent construction control to connect with future stages.
Horizontal Blanket Drain	6.1b	Simple construction	Ineffective in high anisotropy conditions.
Discrete Internal Drain	6.1c	Relatively inexpensive and independent of future embankment raising	Partial seepage interruption; effectiveness depends on anisotropy.
Chimney Drain and Outlet Sections	6.1d	Positive seepage interception	Expensive and difficult to construct.

embankment may be needed. A zoned embankment consists of multiple material zones, generally including an impervious (or low-hydraulic-conductivity, fine-grained material) core or upstream zone of limited width and additional zones of coarse material that provide strength and erosion resistance. Employing such a zoned embankment concept can reduce material requirements for internal drainage structures and structural embankment zones.

At some coal refuse disposal sites, two zones are incorporated into the embankment cross section – a relatively impervious soil zone in the upstream section and coarse material such as mine spoil, granular borrow material or coarse coal refuse in the downstream section. If controlling the volume of seepage is not of primary importance, zoned embankments can be designed with the object of lowering the phreatic surface in the downstream face of the embankment. The primary design consideration in such cases is that the hydraulic conductivity of the downstream zone be sufficiently high to discharge the water seeping through the core or upstream zone without an elevated phreatic surface.

Figure 6.2 illustrates configurations of zoned embankments most commonly used in dam construction. Figures 6.2a and 6.2b show a vertical core and a sloping core, respectively. Figure 6.2c illustrates a zoned embankment consisting of finer soil in upstream portion of the dam and coarse material in the downstream portion. An upstream zone may be preferred for slurry impoundments, provided erosion from pool-level fluctuations or runoff is not significant or can be controlled. Alternately, zoned coarse refuse dams, in which the upstream zone receives more compactive effort to increase material breakdown and to lower hydraulic conductivity, may be specified. However, many coarse refuse dams are not zoned, taking advantage of the fine coal refuse deposited in the impoundment that may be as effective as zoning in limiting seepage, provided that: (1) the impoundment pool is maintained at a low level and does not surcharge the upstream embankment face and (2) the response of the phreatic surface to increased pool levels as a result of storm runoff will not compromise embankment stability.

A description of important features related to impervious zone and shell design for zoned embankments is provided in the following text.

Impervious Zone Design

Although small amounts of seepage are typically present in the low-hydraulic-conductivity portion of an embankment, these embankment components are generally referred to as impervious zones. For design of impervious zones, the primary considerations are the type of impervious zone and the thickness and material used for their construction. The upstream zone of a zoned embankment may serve a similar purpose, particularly for coal refuse impoundments.

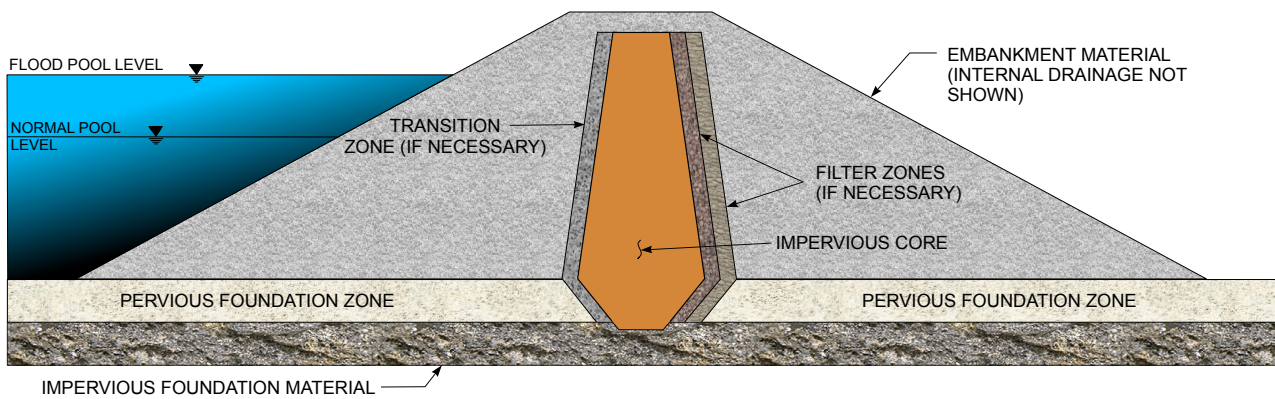

6.2a VERTICAL CORE

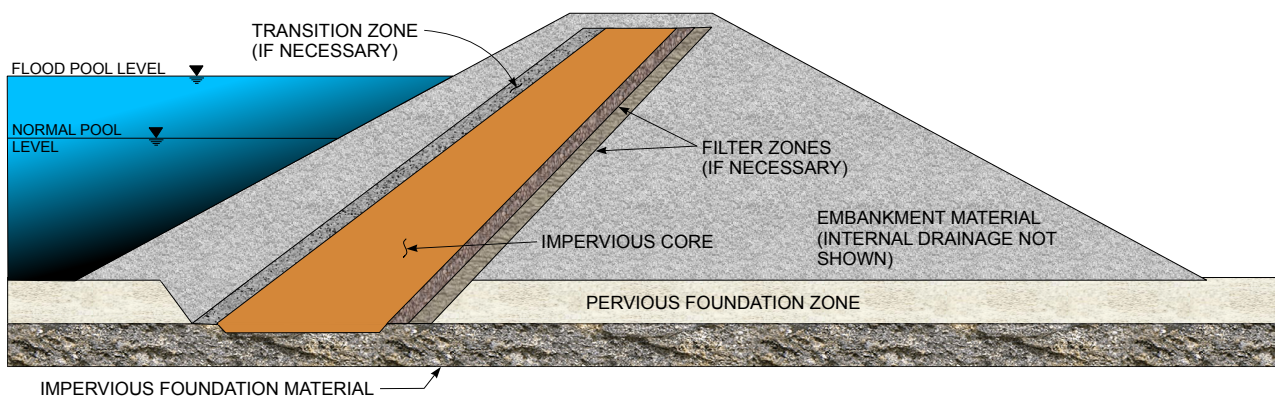

6.2b SLOPING CORE

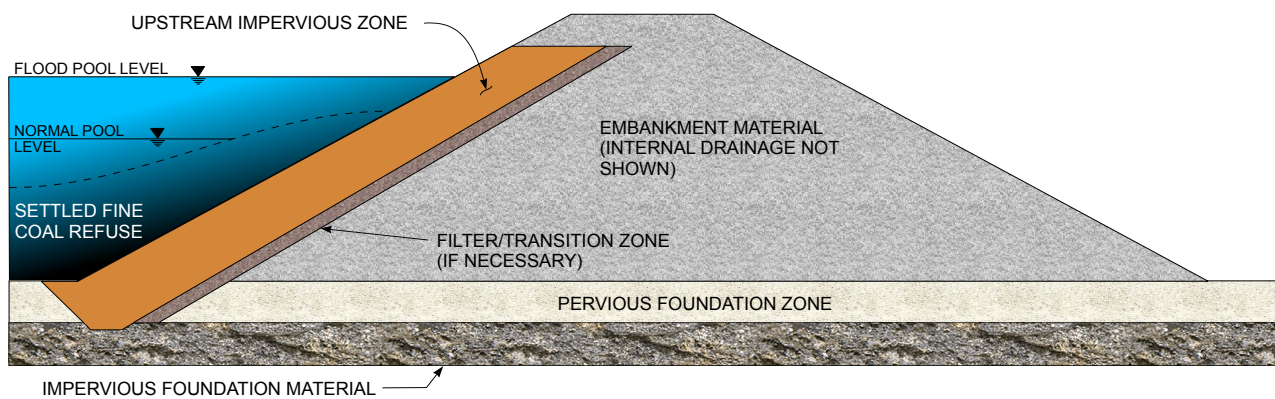

6.2c UPSTREAM IMPERVIOUS ZONE

FIGURE 6.2 ZONED EMBANKMENTS WITH IMPOUNDMENTS

Impervious Zone Type

Both vertical and sloping impervious zones have advantages, as described in [Table 6.13](#). The selection of the type of zoning of the material must be determined on an individual site basis. Valuable additional discussion of the design of embankments with impervious zones is provided in USBR (1992a).

TABLE 6.13 RELATIVE ADVANTAGES OF VERTICAL AND SLOPING EMBANKMENT CORES

Vertical Core	Sloping Core
1. Higher confinement pressure, more uniform settlement with increased embankment load, and shear strength is not as critical as with a sloping core.	1. The main downstream portion of the embankment can be constructed first and the impervious core placed later without disrupting construction operations. This advantage allows the downstream portion of the embankment to be constructed year round, even if controlled construction of the core can be done only during short, good-weather periods.
2. Higher pressure is present between the impervious core and the foundation, providing additional protection against leakage along the contact surface.	
3. For a given volume of impervious soil material, the thickness of the vertical core will be slightly greater than that of sloping core.	2. Filter layers between the core and the upstream and downstream portions of the embankment can be made thinner and constructed more easily.
4. If it becomes necessary to grout the foundation after the embankment has been raised to a significant height, the grouting can be conducted from the crest of the embankment through the core and directly into the foundation, as opposed to a sloping core, where the tie between the core and the foundation is beneath the impoundment.	3. The core construction can be staged easily if the embankment is expanded by the downstream staged construction method.
5. A vertical core is not subject to damage from sloughing or erosion of the upstream toe.	

Impervious Zone Thickness

The impervious zone thickness is normally governed by practicalities (Sherard et al, 1963), including: (1) tolerable seepage volume, (2) thickness that will permit proper construction, (3) type, quality and cost of available low-hydraulic-conductivity material, (4) type, quality and cost of available material for any filter layers between the impervious zone and the adjoining downstream soil, and (5) the quantity and quality of available soil/rock for the shell. While subsequent research and testing has provided refinement in the design of impervious zone thickness, the following criteria developed for water retention dams (USBR, 1992a; McCook, 2002) may serve as preliminary guidelines for acceptable impervious zone thickness for other impounding embankments, recognizing that other dimensions/configurations may be suitable pending seepage and stability analyses:

- Cores with a thickness greater than 30 percent of the depth of water head have proven satisfactory for many dams under diverse conditions; for a starter dam, a core of this thickness will probably be adequate for many types of impervious core material and embankment heights.
- Cores with a thickness of 15 to 20 percent of the depth of water head are considered thin, but if adequately designed and constructed filter layers are used, they will probably be satisfactory under most circumstances.
- Cores with a thickness of less than 10 percent of the depth of water head should be considered only in circumstances where a large leak through the core would not lead to embankment failure or unacceptable environmental conditions; very carefully designed and constructed filter layers should be considered.

Impervious zones of limited width, governed by material properties and availability as well as construction practicalities, have proven advantageous in limiting seepage at starter dams and slurry

impoundments. As discussed above, the deposition of fine refuse slurry may also be effective at limiting seepage provided that: (1) the impoundment pool is maintained at a low level and (2) the response of the phreatic surface to increased pool levels as a result of storm runoff will not compromise embankment stability.

Impervious Zone Material

Impervious zone material is usually selected based on specific requirements for controlling seepage and the availability of suitable material at the site. Typically, fine-grained soil is used for such construction. The potential for failure resulting from loss of impervious zone material and leakage caused by cracking or differential slippage within the impervious zone will influence the design, the materials used and the construction procedure. The possibility of excessive leakage due to cracking is a particularly important consideration for embankments on soft foundation material, in areas susceptible to subsidence, or in regions of high seismic activity. Brittle soil behavior and cracking problems often can be minimized by placing the impervious zone material at a higher than optimum moisture content. [Figure 6.3](#) provides a classification of materials according to resistance to piping and cracking. If foundation settlements are expected to be high, a suitable internal drainage layer should be placed immediately downstream of the impervious zone to control seepage resulting from possible cracking.

Dispersive clay soils have a preponderance of sodium cations in their pore water in contrast to most clays, which have a preponderance of calcium and magnesium cations in their pore water. A hole through a dispersive clay will increase in size as water flows through (due to the breakdown of the soil structure), whereas a hole in a non-dispersive clay will remain essentially constant in size. Dispersive clays should not be used in dam construction because they are extremely susceptible to piping. The crumb test (ASTM D 6572) can be conducted in the field or laboratory and may indicate if soils are dispersive. The dispersion potential can most reliably be determined using the pinhole test (ASTM D 4647). The dispersion potential of clay for several ranges of measured dispersion is provided in [Table 6.14](#) (Sherard et al., 1976).

Design of filters for impervious soils used for the core can be critical for the downstream interface with the shell, but is generally less critical for the upstream interface for a coal refuse impoundment because reservoir fluctuations are minimal. Sherard et al. (1985) and McCook (2002) address filter criteria and hydraulic gradient issues associated with impervious soils in dams; this topic is further discussed in [Section 6.6.2](#).

Shell Design

Embankment shell zone material typically is selected from granular material at the site. Coarse coal refuse, mine spoil and rock excavated from the construction of water drainage systems or haul roads are generally suitable for shell construction. The earthfill portion (upstream zone or core) may be zoned or protected by graded filter zones, as discussed in [Section 6.6](#). The use of rockfill is governed by economy and structural stability in addition to slope protection. If a plentiful supply of suitable rock is available at low cost, it is often possible to steepen the slopes of the adjoining earthfill portion by providing additional free-draining rock on the downstream face, resulting in added stability. With careful planning and design, the rockfill section of the starter dam can be utilized as a toe drain for future expansion of the facility by the upstream method of construction. However, this may pose a design constraint if the expansion is by the downstream method.

6.3.1.3 Foundation Seepage Control

A very important consideration in the design of an impounding embankment is the control of seepage through the underlying foundation materials. Unlike a water storage reservoir, there is little need to retain water in a slurry disposal facility. Therefore, minimizing seepage through the foundation

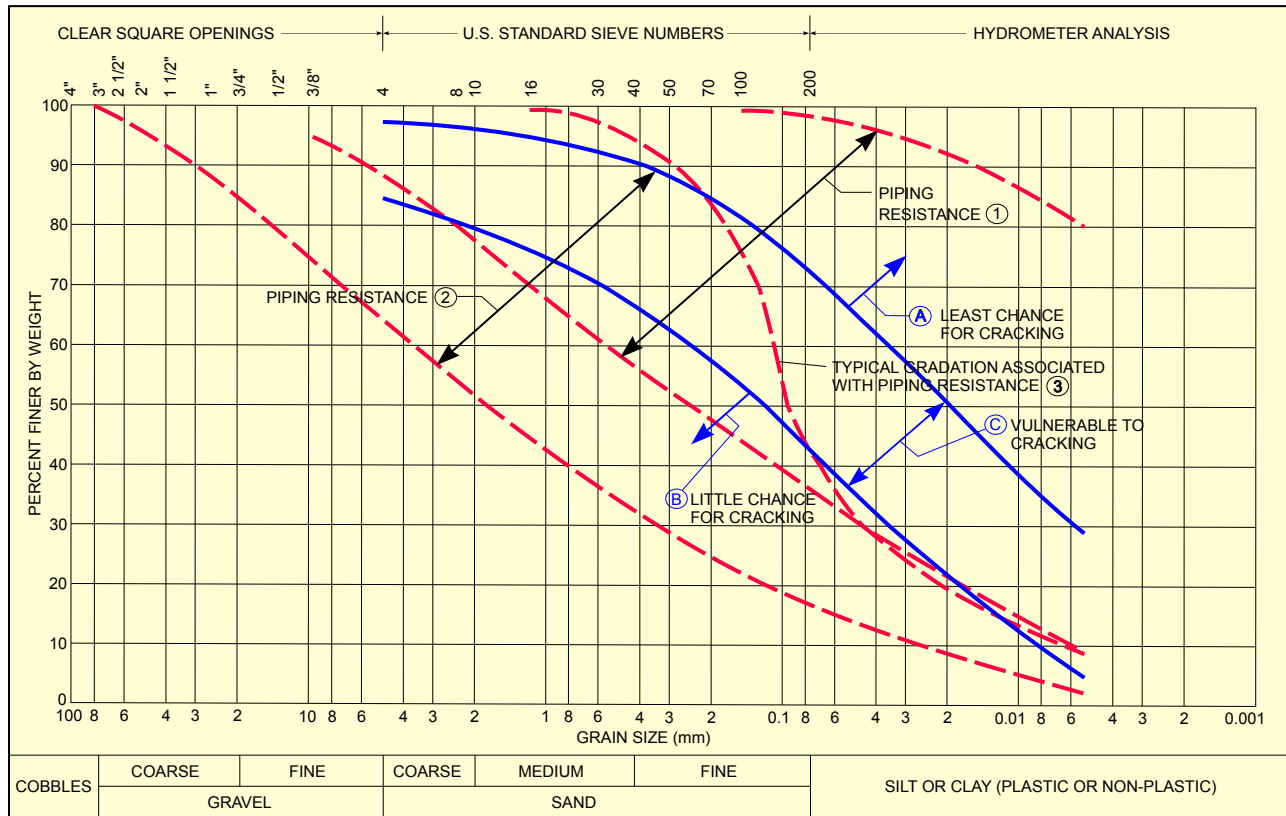

CATEGORY	MATERIAL	CHARACTERISTICS
PIPING RESISTANCE ①	CL AND CH WITH $P_i > 15$, WELL GRADED SC WITH $P_i > 15$.	GREATEST RESISTANCE TO PIPING. SMALL AND MEDIUM CONCENTRATED LEAKS WILL HEAL THEMSELVES. EMBANKMENT MAY FAIL AS A RESULT OF SLOWLY PROGRESSIVE PIPING CAUSED BY LEAK OF ABOUT ONE-HALF CFS.
PIPING RESISTANCE ②	CL AND ML WITH $P_i < 15$, WELL GRADED SC AND GC WITH $7 < P_i < 15$.	INTERMEDIATE RESISTANCE TO PIPING. SAFELY RESISTS SATURATION OF LOWER PORTION OF DOWNSTREAM SLOPE INDEFINITELY. MAY FAIL EVENTUALLY AS A RESULT OF EROSION CAUSED BY A SMALL CONCENTRATED LEAK OR BY PROGRESSIVE SLOUGHING. IF A LARGE LEAK DEVELOPS, PIPING CAUSES FAILURE IN A SHORT TIME.
PIPING RESISTANCE ③	SP AND UNIFORM SM AND ML WITH $P_i < 7$.	LEAST RESISTANCE TO PIPING. USUALLY FAILS IN A FEW YEARS AFTER FIRST RESERVOIR FILLING IF SEEPAGE IS ABLE TO BREAK OUT ON DOWNSTREAM SLOPE. SMALL CONCENTRATED LEAK ON DOWNSTREAM SLOPE CAN CAUSE FAILURE IN A SHORT PERIOD OF TIME. HIGH DENSITY FROM COMPACTION INCREASES RESISTANCE SIGNIFICANTLY.
CRACKING RESISTANCE A	CH WITH $D_{50} < 0.02\text{MM}$ AND $P_i > 20$.	HIGH POST-CONSTRUCTION SETTLEMENT, PARTICULARLY IF COMPACTED DRY. HAS SUFFICIENT DEFORMABILITY TO UNDERGO LARGE SHEAR STRAINS FROM DIFFERENTIAL SETTLEMENT WITHOUT CRACKING.
CRACKING RESISTANCE B	GC, SC, SM, SP WITH $D_{50} > 0.15\text{MM}$.	SMALL POST-CONSTRUCTION SETTLEMENT. LITTLE CHANCE FOR CRACKING UNLESS POORLY COMPACTED AND LARGE SETTLEMENT IS IMPOSED ON EMBANKMENT BY CONSOLIDATION OF THE FOUNDATION.
CRACKING RESISTANCE C	CL, ML AND SM WITH $P_i < 20$, $0.15\text{MM} > D_{50} > 0.02\text{MM}$.	MEDIUM TO HIGH POST-CONSTRUCTION SETTLEMENT AND VULNERABLE TO CRACKING. SHOULD BE COMPACTED AS WET AS POSSIBLE CONSISTENT WITH STRENGTH REQUIREMENTS.

(DOD, 2005)

FIGURE 6.3 RESISTANCE OF CORE MATERIALS TO PIPING AND CRACKING

is not as critical to the design as it is for storage reservoirs. Where seepage occurs, it must be controlled such that it does not adversely affect the safety of the embankment or result in environmental impacts. The foundation conditions likely to be encountered beneath the starter dam are: (1) pervious foundation, (2) impervious foundation, or (3) impervious stratum at the surface underlain by a pervious stratum. An additional foundation seepage concern at some coal refuse facilities is the potential for fracturing due to subsidence of the ground surface above underlying mines.

Pervious foundations may consist of boulders, gravels, sands or mixtures thereof. For such foundations, measures to minimize seepage quantity and to provide controlled seepage discharge are

TABLE 6.14 CLAY DISPERSION POTENTIAL

Percent Dispersion ⁽¹⁾	Dispersive Tendency
Over 40	Highly Dispersive (do not use)
15 to 40	Moderately Dispersive
0 to 15	Resistant to Dispersion

Note: 1. The ratio between the fraction finer than 0.005 mm in a soil-water suspension that has been subjected to a minimum of mechanical agitation and the total fraction finer than 0.005 mm determined from a regular hydrometer test times 100.

(SHERARD ET AL., 1976)

normally required. Control measures may include low-hydraulic conductivity barriers (e.g., cutoff trench and backfill) to decrease or virtually stop seepage, or a collection system can be provided beneath the downstream portion of the embankment to control the discharge of seepage. If seepage control and/or collection systems are not intended to be employed, the safety (including the potential for piping of foundation or embankment materials) and environmental ramifications should be carefully evaluated, and suitable measures should be employed to monitor pore pressures, if necessary.

The most common methods used for controlling foundation seepage are construction of a low-hydraulic-conductivity cutoff through the pervious foundation material and construction of an impervious blanket extending far enough upstream to sufficiently restrict the flow. In some situations, construction of an impermeable liner beneath the impoundment may also be used to address foundation seepage control. These methods are illustrated in Figure 6.4. Normally, if the pervious foundation material is thin and excessive groundwater problems due to excavating in the valley bottom are not anticipated, the low-hydraulic-conductivity cutoff is the least expensive method. Important considerations in the design and construction of seepage cutoffs are presented by Sherard et al. (1963) and USBR (1987a, 1992a). Procedures for designing an impervious blanket are presented by Cedergren (1989).

Where seepage through the foundation is allowed to occur, a collection system is almost always provided. The two major negative effects of allowing seepage to occur are: (1) a decrease in the factor of safety against instability of the embankment due to high pore pressures in the foundation and (2) the potential for piping in the foundation. If the foundation soil is not stratified in the horizontal direction, seepage control can be provided by a horizontal blanket drain (Figure 6.1a). This method normally requires analysis of the path of the seepage and assurance during placement of the blanket that it is directly tied to underlying pervious material. Seepage is collected at the downstream end of the blanket and discharged at a predetermined location near the valley bottom.

Other methods of controlling seepage through a pervious foundation include a deep drainage trench constructed near the toe of the embankment and a relief well system, as discussed in greater detail in Section 6.6.2.3.4. Measures associated with the design and management of the impoundment and clarified water level can also aid in controlling seepage. In some cases, impoundment cells for clarified water are developed in the upstream portion of the impoundment. The deposition of fine refuse and resulting longer seepage path aids in restricting seepage beneath the downstream embankment.

Impervious foundations typically consist of massive rock and predominantly clayey soils. When an impoundment is to be constructed upon impervious foundation materials, seepage beneath the embankment is not a major design consideration if a proper seal is placed between the embankment and the foundation. Methods of foundation preparation that effectively create a seal and references to supplemental technical publications on grouting and rock preparation are presented in Chapter 11.

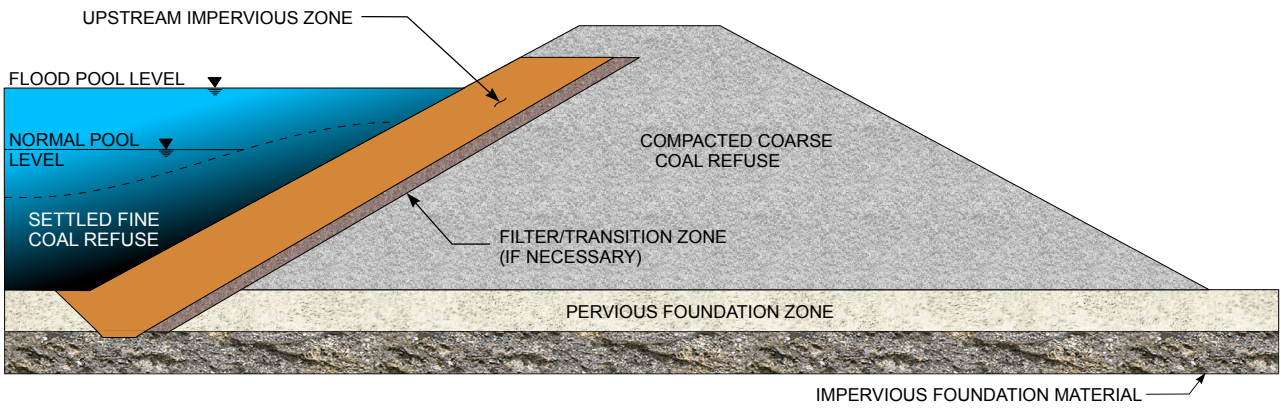

6.4a PERVIOUS FOUNDATION CUTOFF WITH ZONED EMBANKMENT

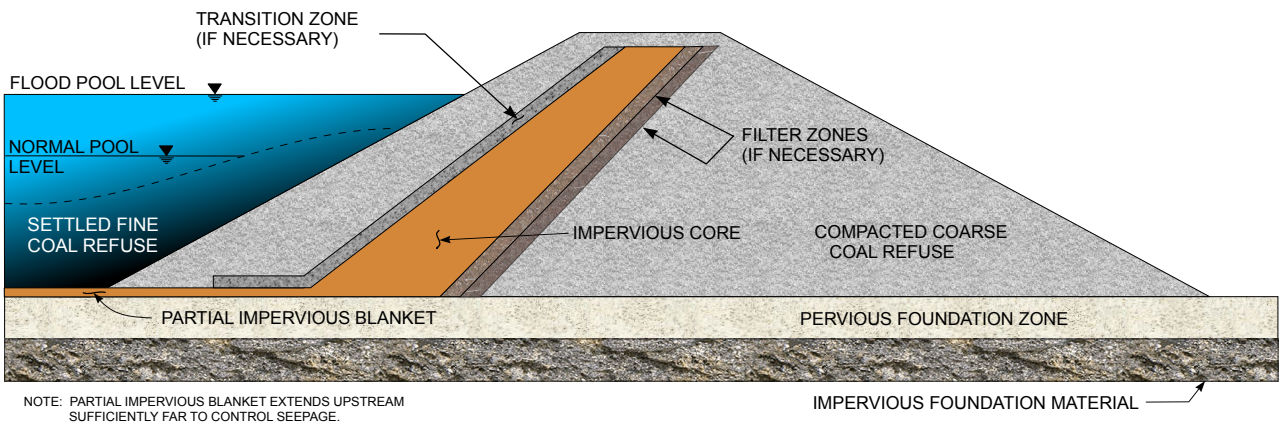

6.4b IMPERVIOUS BLANKET

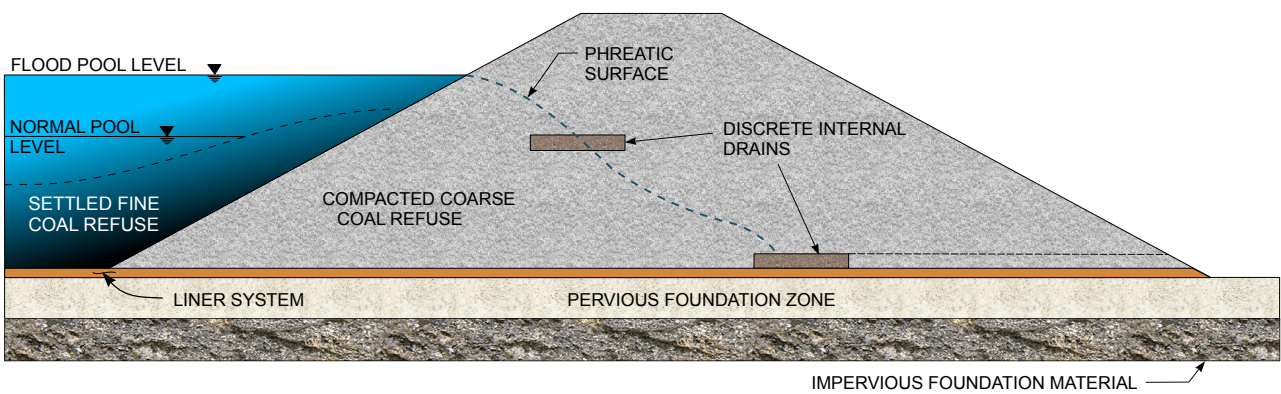

6.4c IMPERVIOUS LINER WITH HOMOGENEOUS EMBANKMENT

FIGURE 6.4 SEEPAGE CUTOFFS FOR PERVIOUS FOUNDATIONS

For disposal facilities where impoundments are constructed upon an impervious foundation, the National Coal Board (1970 and 1972) has suggested an effective concept for allowing controlled drainage from settled slurry. Granular drainage and filter material is placed beneath the impoundment area prior to filling. The drainage and filter material transition to pipes that pass under the embankment to a downstream collection system or to a discharge outlet. In some cases, to assure complete drainage, this zone is constructed over the upstream face of the embankment. D'Appolonia (1988) conducted OSM-sponsored research and implemented a design for an impoundment internal drain structure to improve consolidation of the fine coal refuse and to intercept seepage before it enters the coarse refuse embankment, thus mitigating acid mine drainage potential. This concept is illustrated in Figure 6.5. Another method to improve drainage and consolidation of fine coal refuse is installation of wick drains.

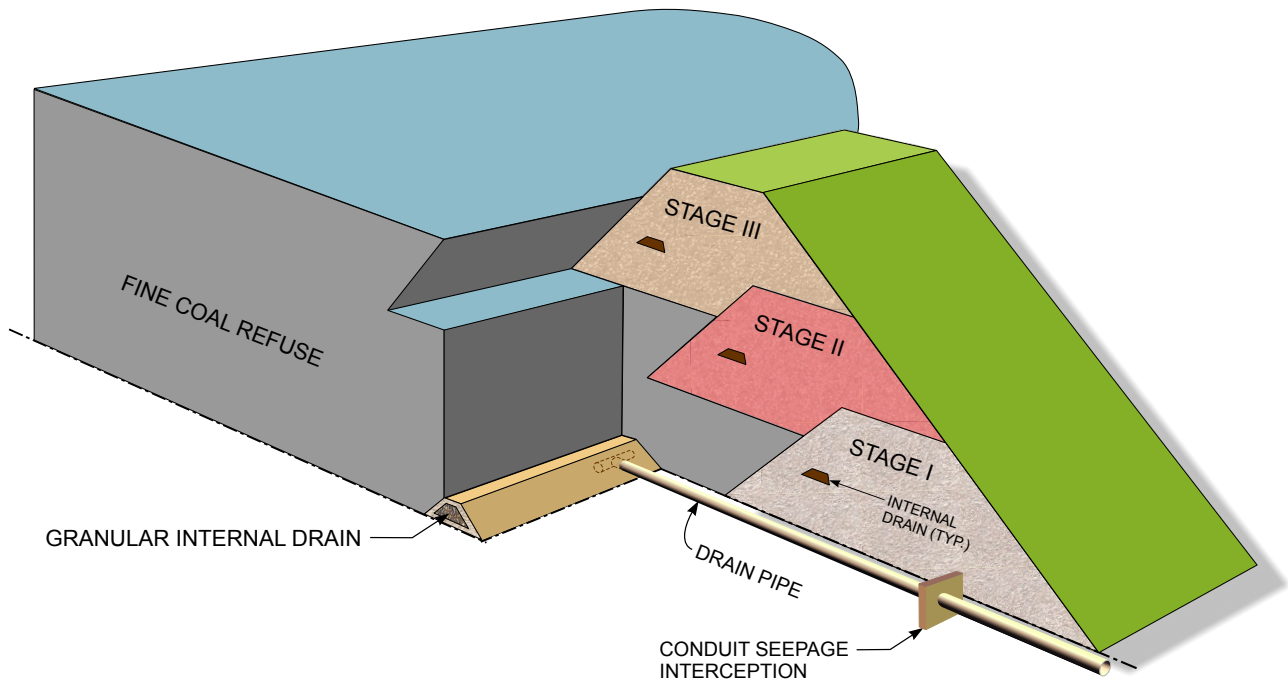

FIGURE 6.5 IMPOUNDMENT INTERNAL DRAIN CONCEPT

For the case of an impervious stratum at the surface overlying more pervious strata below, there is potential for high pore-water pressure to occur downstream of the dam. This may cause blow outs, boiling, piping or instability at or beyond the downstream toe. An upstream cutoff trench, deep drainage using relief wells or construction of berms should be considered in such cases.

6.3.2 Non-impounding Embankments

Non-impounding embankments require many of the same design and construction considerations as impoundments. Careful geotechnical investigation can: (1) identify potentially unstable soils that are incapable of sustaining embankment loadings and (2) decrease the probability of groundwater impacts by identifying certain site characteristics that should either be avoided or recognized during the design phase. Safety may become a major design factor when:

- The disposal facility is located in areas where failure would have a high possibility of taking lives and could seriously damage infrastructure or buildings.
- The facility is located immediately above a stream and significant movement of the embankment could block or restrict the flow, possibly creating a temporary impoundment that could release a flood wave upon breaching of the sloughed material.

- The facility is constructed across a large valley with a significant watershed or it may temporarily impound water during some stage of development, despite the presence of drainage systems.

Embankments should not impede drainage, and cross-valley configurations should be avoided because they can retain water and be subject to classification by MSHA as an impoundment. MSHA (2007) presents factors to be considered in this regard and also cautions that reclamation at abandonment can require significant regrading to address drainage concerns.

The following discussion of important design considerations for non-impounding embankments does not specifically address cases where a high safety hazard may exist. The designer must recognize special safety hazards and formulate the investigation program and analyses accordingly. To properly plan and design a non-impounding coal refuse embankment, the following questions should normally be answered:

- Considering the required volume and the disposal facility geometry, what is the smallest quantity of constructed material that could form the critical downstream structural portion of the embankment with assured stability?
- If the embankment were to temporarily impound water, could it lead to pore-water pressure conditions that are hazardous to the stability of the embankment?
- Is an impervious liner system needed in order to limit seepage or infiltration of the groundwater?
- Should an internal drainage system be placed under critical portions or all of the disposal facility to control saturation for stability purposes or to collect seepage for treatment before discharge?

Non-impounding coal refuse embankments typically accommodate disposal of coarse, combined, and dewatered fine coal refuse. Well-graded coarse refuse may be generated without significant excess moisture, such that internal drainage provisions are primarily directed at control of natural springs or infiltration. Consequently, seepage control and slope stability can readily be addressed with minimal internal drainage requirements and normal placement and compaction of materials. Combined refuse and dewatered fine refuse generally contain excess moisture when they are generated, and greater measures are required for seepage control and slope stability. Such embankments may be zoned to establish structural downstream zones for stability and may incorporate internal drainage control structures, allowing for upstream zones where the material consistency and strength are less important. However, applicable regulations for the construction of “refuse piles” must be followed.

Several examples of designs for non-impounding embankments, including provisions for seepage control, are illustrated in [Figure 6.6](#). Figures 6.6a and 6.6b show drainage system concepts previously discussed in Section 6.3.1, where seepage is controlled by internal drainage systems. The previous discussion of internal drain materials and their gradation, and of the need for filters, is also applicable to this type of construction. The full extent of seepage control and drainage systems must be determined on a project-by-project basis considering site conditions, the economics of various methods of providing embankment stability, the cost of leachate treatment, and appropriate regulations.

For some disposal facilities, usually depending on site location and condition, seepage impacts on the groundwater regime may need to be mitigated. In such cases, a relatively impervious liner composed of fine-grained borrow materials should be constructed beneath the disposal facility. This can be accomplished as the facility is being constructed by rearranging and compacting native soils or by using borrow soils, as illustrated in Figure 6.6c. At some sites, a geomembrane or geosynthetic clay liner (GCL) may

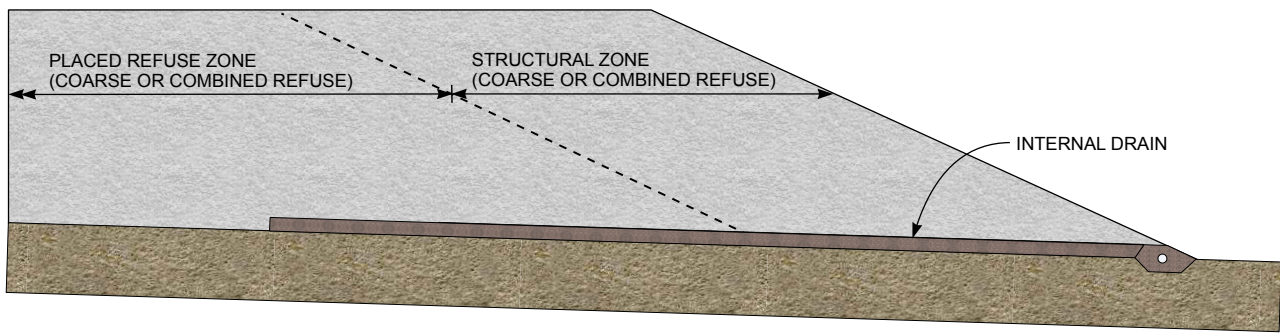

6.6a BOTTOM INTERNAL DRAIN

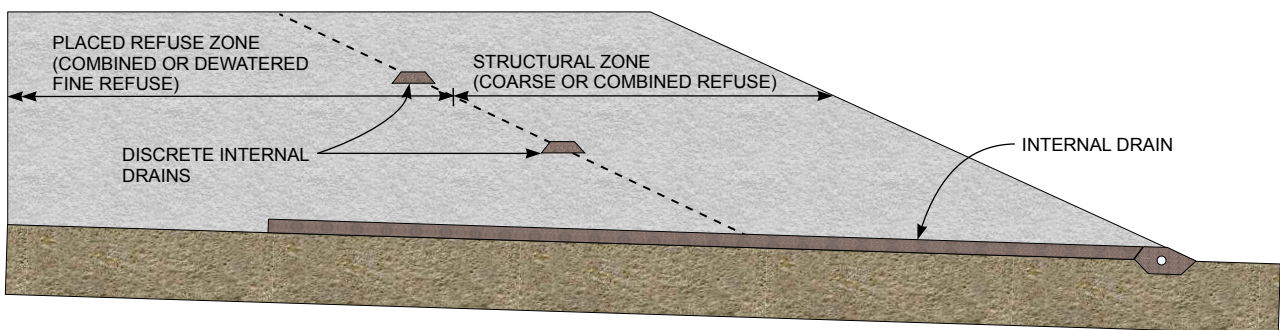

6.6b BOTTOM AND DISCRETE INTERNAL DRAINS

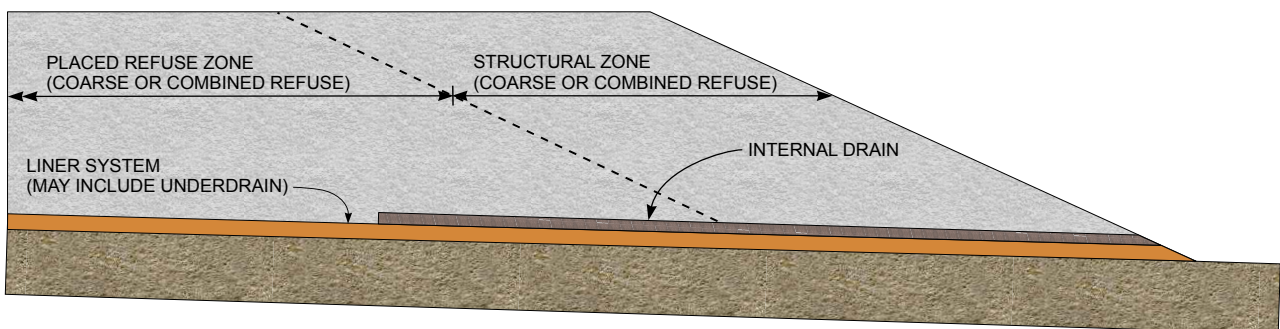

6.6c BOTTOM INTERNAL DRAIN WITH LINER SYSTEM

FIGURE 6.6 NON-IMPOUNDING EMBANKMENTS

be used as an impervious liner if satisfactory borrow materials are not available. Selected portions of the impervious zone may be covered by drainage materials to collect and transport leachates to a common point for treatment and/or discharge. The introduction of liner materials may affect the stability of the embankment and thus potentially impact the design slopes or configuration of a disposal facility.

Typically, groundwater seepage or mine discharge is collected and conveyed in a manner such that it cannot enter the refuse. [Figure 6.7a](#) shows a seepage collector drain comprising a collection zone and a

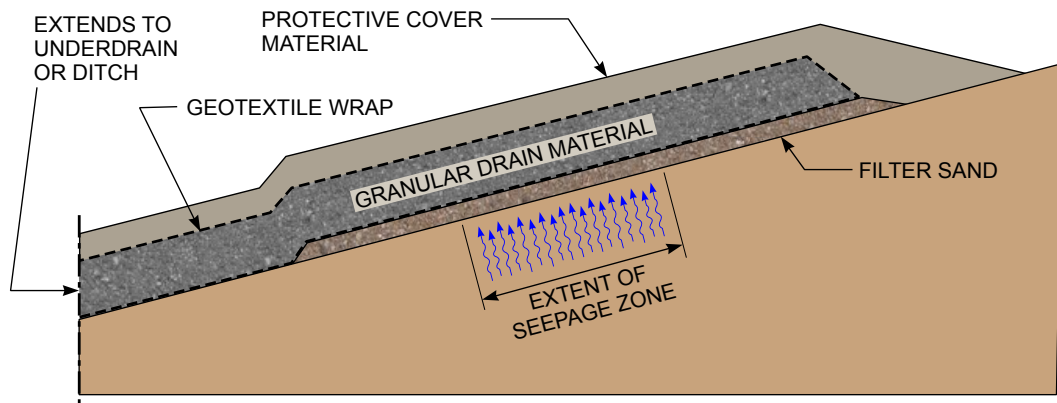

6.7a SPRING COLLECTION ZONE WITHOUT LINER SYSTEM

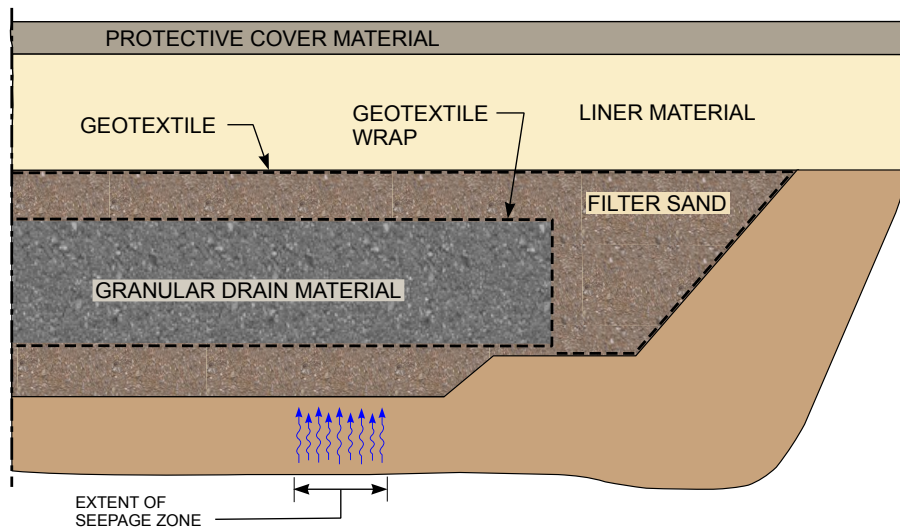

6.7b SPRING COLLECTION ZONE AS PART OF LINER SYSTEM

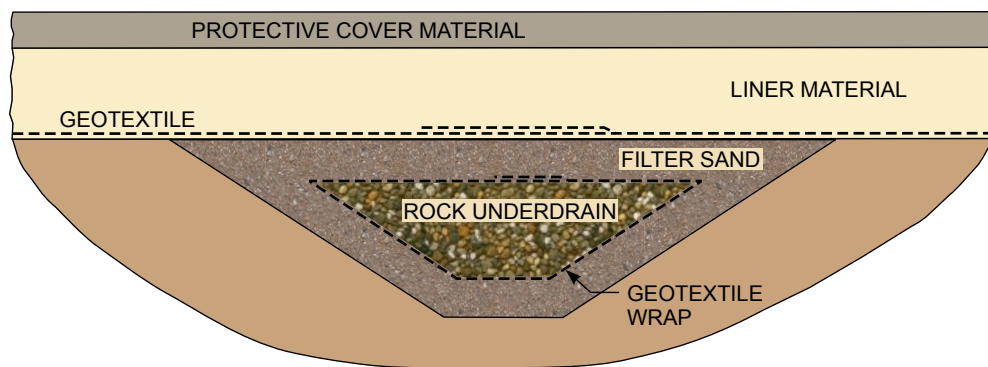

6.7c ROCK UNDERDRAIN AS PART OF LINER SYSTEM

FIGURE 6.7 EXAMPLE SPRING COLLECTION ZONES AND ROCK UNDERDRAIN

conveyance system. The collection zone consists of granular material covered with a granular filter layer and/or geotextile. The collected water is discharged through the granular drain or pipe to the nearest internal drainage system or beyond the downstream toe. The granular filter layer or geotextile situated between the water collecting zone and the overlying refuse and perforated pipes incorporated into the drainage system (if present) should be designed using procedures discussed in Section 6.6. Inclusion of an impervious liner over the collection zone, as shown in Figure 6.7b, may be appropriate for preventing embankment seepage from entering the collected groundwater and to minimize the volume of poor-quality water that may require treatment. Rock underdrains may be placed in valley bottoms to collect outflows from springs. Figures 6.7b and 6.7c show examples of spring collection zones and rock underdrains for a lined facility. Spring collection zones and rock underdrains should be designed for compatibility with surrounding materials using the filter criteria presented in [Section 6.6.2](#).

Underground mine voids may cause subsidence that can impact an overlying embankment, potentially disrupting liners and internal drainage structures. Measures for evaluating and addressing potential subsidence problems are discussed in Chapter 8.

6.3.3 Slurry Cell Embankments

Slurry cell embankments may be classified as impounding embankments or non-impounding embankments depending on the configuration and storage capacity of active, uncovered cells and the potential for multiple cells to be involved in a failure. For facilities with significant coal refuse production rates, it is difficult to keep the active cell capacity below the impoundment classification limit, and thus the aim is to design the facility so that it can be classified as having low hazard potential. Such a system requires a design and construction sequence that minimizes the volume of active cells and provides for timely drainage, covering, and consolidation of completed cells so that the fine coal refuse is not flowable.

For slurry cell systems that are designed and classified as impoundments, the following geotechnical considerations are applicable:

- Seepage control – An internal drainage system and foundation cutoff system designed to intercept seepage and prevent it from impacting the structural zone or toe of the embankment and a foundation treatment and liner system if necessary to address leachate migration from the disposal facility. Slurry cells have limited water and slurry storage and thus represent less significant sources of seepage than conventional impoundments for fine coal refuse slurry disposal.
- Slope stability – Static slope stability is maintained by a structural zone constructed from coarse coal refuse or borrow material with sufficient width to effectively contain and isolate the slurry cells from affecting potential failure surfaces. Seismic stability and deformations may be of less concern because individual cells tend to be shallower deposits of fine coal refuse that are better drained and consolidated by layers of coarse refuse or borrow materials. Sloughing and erosion considerations are essentially the same as for other refuse embankments. Slurry cell disposal requires coarse refuse or borrow material for the cell structures and covering of completed cells and for any structural zones that may be part of a valley-fill configuration. Thus, to address slope stability, slurry cell systems may require more coarse refuse or borrow material for structural elements and cell construction than more traditional types of impounding embankments.
- Drainage structures – Structural foundations and excavation slopes for diversion channels, principal and emergency spillways, conduits and other auxiliary structures associated with impoundments.

- Underground mines – Stability, sealing of mine openings, and infiltration into underground mine workings. Slurry cell systems provide a means to mitigate breakthrough impacts of an impoundment into underground mine workings.

Slurry cell embankments that are designed with limited impounding capacity for water, sediment or slurry so that they do not meet the impoundment size criterion (as discussed in Section 3.4.1) are less sensitive to the impacts of seepage on stability, provided that effective drainage measures are incorporated into the cells. Such embankments may not need principal and emergency spillways and conduits associated with impoundments, thus reducing geotechnical considerations.

6.3.4 Embankment Construction Staging

Embankments are raised in stages using one or more modifications of three basic approaches: (1) upstream method, (2) downstream method, or (3) centerline method. In fact, many disposal plans use a combination of upstream and downstream methods for staging. Figures 6.8 and 6.9 show example configurations of embankments constructed using a combination of the upstream and downstream methods. This section describes common procedures for staging the development of a new embankment or extending the life of an existing embankment. In the previous two sections, general concepts for controlling groundwater and seepage are discussed; they are repeated here only as needed for explaining staging methods. The inclusion of drainage systems in the overall embankment and its staged parts must be designed on a site-by-site basis.

6.3.4.1 Upstream Method

In the upstream method of construction, the crest of the embankment is shifted progressively upstream from the starter dam, as shown in Figure 6.8. The upstream method has several advantages and disadvantages from an operational and safety standpoint, but one important drawback is the engineering and design requirements necessary to address structural performance under earthquake loading conditions. While there has not been a reported failure of a fine coal refuse impoundment due to earthquake loadings in the U.S., other similar tailings impoundments and hydraulic-fill dams have failed during or following seismic activity. The engineering analyses presented in Section 6.6 and Chapter 7 employ current methods for evaluating material properties and loadings for design.

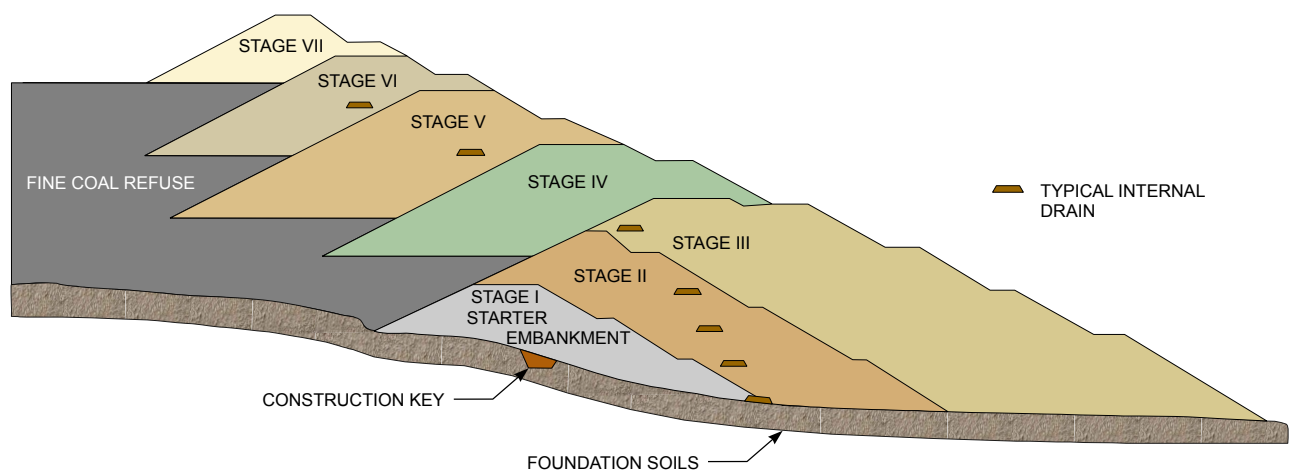

NOTE: TAKEN FROM ACTUAL STAGING FOR VALLEY FILL SITE IN PENNSYLVANIA. THE FIGURE SHOWS UPSTREAM CONSTRUCTION METHOD (STAGES IV - VII) FOLLOWING INITIAL DEVELOPMENT (STAGES I - III).

FIGURE 6.8 UPSTREAM CONSTRUCTION FOLLOWING INITIAL DEVELOPMENT

The major advantages of the upstream method are:

- The structural fill volume is minimized because part of the new embankment is constructed in stages on top of the existing embankment and part is constructed over the deposited fine refuse slurry.
- The downstream face of the constructed embankment is the final face of the completed embankment, and vegetation and other environmental control measures can be performed on a permanent basis.
- The operational requirements such as haul and access roads, culverts, diversion and perimeter ditches can be constructed to serve the entire useful life of the facility.
- The impoundment watershed area decreases with the progress of embankment construction, requiring less volume for storm runoff handling with time.
- The starter dam, if properly designed, can provide support and become part of the internal drainage control for the subsequent embankment development.

When fine coal refuse slurry is deposited in an impoundment, grain-size sorting and layering occurs in both the horizontal and vertical planes during the depositional process. Peripheral discharge of slurry, either by single-point discharge or by multiple discharges, results in the formation of a “beach” around the discharge point. The coarser particles settle close to the discharge point and the finer particles concentrate in the upstream portion of the impoundment. The depositional process may also result in the formation of horizontal layers of coarser and finer fractions of the refuse and affect the engineering properties of the settled fine refuse.

The fine coal refuse particles settling from the slurry accumulate in a very loose state initially and have a high void ratio and moisture content. These loose deposits consolidate with time as water is expelled from the voids between the particles. Consolidation is influenced by such factors as the effective pressure of the overlying material, the hydraulic conductivity of the deposit and surrounding soil, the distance that water must travel to drain and the time during which vertical pressure is applied. Thus, the consolidation of fine coal refuse deposits varies spatially within the impoundment. Even after consolidation under self weight for years, such deposits may have high void ratios and high moisture contents, affecting the shear strength of the fine refuse. This should be borne in mind by the designer, if the upstream method of construction is utilized for embankment raising.

The disadvantage of the upstream method is that construction occurs atop previously deposited, unconsolidated tailings. Under static loading conditions, there is a limiting height to which materials can be placed without the risk of a shear failure. In the initial placement of materials for the embankment stage, normal spreading and compaction procedures cannot be followed until a firm or stabilized base is prepared. Safety of operating personnel during the initial placement of material for an upstream construction stage is very important. Additionally, the height and configuration of an upstream constructed stage will depend on the strength of the material within the zone of shearing, the downstream slope of the embankment, and the location of the phreatic surface within the facility. Under earthquake loading, this type of embankment may be susceptible to failure by strength degradation. However, a stable impoundment can be constructed by following the basic principles of embankment design and through judicious handling of material. A disposal facility constructed using the upstream method must be designed by an engineer experienced in the behavior of soils, coal refuse materials and embankments. Important considerations include:

- The width of the embankment stages or structural fill zones must be adequate to provide downstream slope stability. Upstream slope stability must be demonstrated by adequate factors of safety for failure surfaces that could compromise the crest of the embankment.

- As the embankment is raised, coarse refuse should be placed over settled slurry according to an established schedule, considering the potential for pore pressure buildup and dissipation in the saturated material resulting from the applied loads. To the extent practical, the initial push out for upstream stages should not be placed on submerged fine coal refuse.
- Procedures for placement of materials for the embankment stage should address equipment and operator activity and safety during the initial push-out onto the settled fine coal refuse.
- Reasonable estimates of movement and differential settlements should be used in designing the portion of the embankment constructed over settled slurry.
- The constructed structural portion of each stage of the disposal facility should include a system for controlling seepage, as discussed in [Section 6.3.1](#).
- If the starter dam is intended to become the toe portion of the overall embankment, the downstream zone should be constructed of well-compacted, free-draining material so that it will facilitate the dissipation of pore pressures within the overall embankment.
- In disposal facilities retaining fine refuse slurry, the slurry discharge points should be located adjacent to the embankment and above the pool level. To the extent practical, the discharge point should be periodically moved along the length of the embankment. This will concentrate the coarsest slurry particles adjacent to the embankment, offering the advantage of their greater strength and reducing settlement when the next embankment stage is constructed.
- Analyses of embankment stability should consider dynamic loads and potential for strength degradation. Seismic design and deformation analyses are discussed in Chapter 7.

Exploration, testing, engineering analyses and regulatory review associated with addressing the above considerations are typically more complex and lengthy as compared to designs that employ the downstream method.

6.3.4.2 Downstream Method

In the downstream method of construction, the crest of the embankment is shifted progressively downstream from the starter dam, as designed for the early stages shown in [Figure 6.9](#). This method can be used for embankments with or without impoundments. The major advantages of the method are:

- The embankment is not built on hydraulically-deposited refuse.
- Placement and compaction control can be exercised as required over the entire fill operation.
- The embankment can generally be raised above its initial design height without serious limitations and complicated design modifications.
- Internal drainage systems can be installed, as required, as the construction progresses.
- The embankment can be designed with minimal concern for strength loss of the fine coal refuse under earthquake loadings. This can result in less complex and lengthy exploration, testing, engineering analyses, and regulatory review.

The major disadvantage of the downstream method is that it requires relatively large volumes of fill for raising the embankment. In the early stages of construction, it may not be possible for the mine to

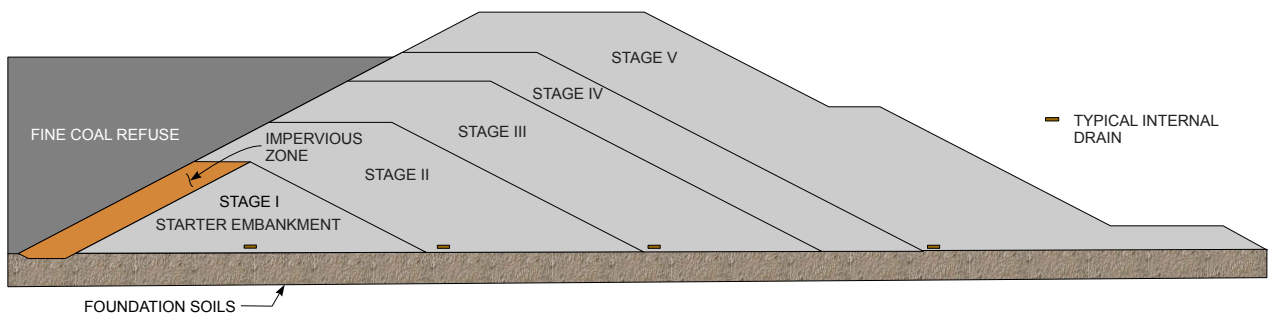

6.9a EMBANKMENT STAGES I - V CONSTRUCTED USING DOWNSTREAM METHOD

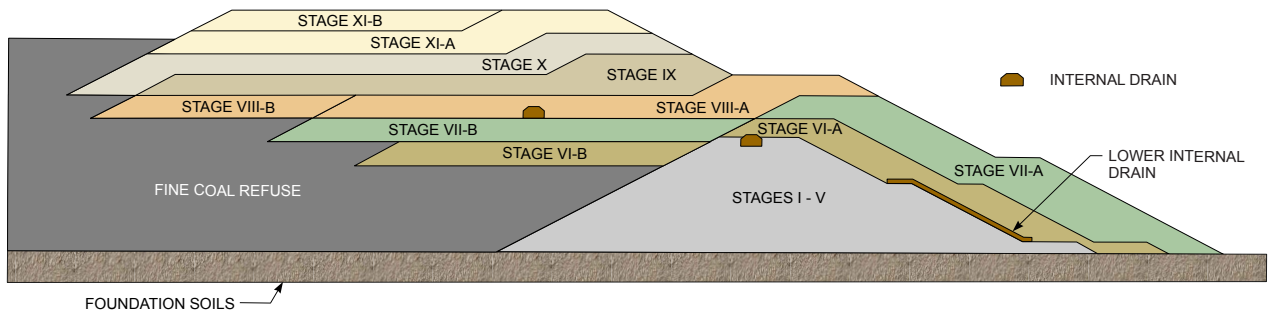

6.9b EMBANKMENT STAGES VI - XI-B CONSTRUCTED USING DOWNSTREAM AND UPSTREAM METHODS

FIGURE 6.9 DOWNSTREAM EMBANKMENT CONSTRUCTION FOLLOWED BY EXPANSION USING THE DOWNSTREAM AND UPSTREAM METHODS

produce a sufficient volume of coarse refuse to maintain the crest of the embankment above the level required for disposal of slurry and routing the design storm. Features such as haul and access roads, culverts, benches, gutters, diversion ditches and perimeter ditches may have to be reconstructed at each stage, resulting in higher cost. Also, the final external face of the embankment is not created until the construction of last stage of disposal, which typically ranges from 5 to 25 years after the start of construction. Consequently, interim faces are exposed to the weather prior to covering by the next stage. These issues may have a considerable financial impact, if the facility has a relatively small drainage area and a decant system is the primary spillway. However, when the construction material is readily available, the downstream method normally results in simpler construction than the upstream method and is also more easily implemented because of the many special requirements of the upstream method.

The arrangement of the drainage and impervious zones within an embankment constructed using the downstream method is usually similar to that of the embankments discussed in [Section 6.3.1.1](#). The zones can be placed in stages corresponding to the height of the embankment.

6.3.4.3 Centerline Method

The centerline method of embankment construction is essentially a variation of the downstream method where the crest of the embankment is not shifted in the downstream direction, but instead is raised vertically above the crest of the starter dam. A major advantage of this method is that the downstream portion of the embankment is built on a firm foundation, and therefore placement and compaction control can be exercised as required over that portion of the embankment. An important consideration in using this method is to maintain an adequate width of structural fill in order to

achieve stability. Other design considerations, as discussed in [Section 6.3.4.1](#) for upstream construction, are also applicable to the centerline method. The centerline method also has all the disadvantages listed in [Section 6.3.4.2](#) for downstream method of construction.

The arrangement of the drainage and impervious zones within an embankment constructed using the centerline method is usually similar to that of the embankments discussed in [Section 6.3.1.1](#). The zones can be placed in stages corresponding to the height of the embankment. The centerline method poses many design, construction, environmental and operational problems, and thus is not generally a preferred method of refuse disposal in the coal industry. This method is primarily used in tailings dam construction where cyclones are used for separating the coarser fraction of the tailings. In the coal industry, a combination of the upstream and downstream methods is typically employed to meet storm water and slope stability criteria and material requirements.

6.3.4.4 Embankments Supplemented with Borrow Material

When the production of coarse refuse is not sufficient to construct the planned height of an impounding embankment, or in other situations dictated by mining conditions, borrow material or mine spoil may be used to supplement the planned construction. The embankment can be constructed from borrow material or mine spoil using the upstream or downstream methods, or these materials can be used in combination with coarse refuse to meet the specified gradation in a zoned embankment, provided that specific zones are designated for such materials. The guidance for seepage control and drainage systems discussed in this Manual is appropriate for construction of embankments of this type.

6.3.5 Special Considerations for Existing Embankments

The engineering principles and procedures for analyzing and designing modifications to existing refuse embankments are the same as those for new facilities. If an existing embankment is not performing adequately, is not consistent with current engineering practice, or involves re-activation of an older site, the following issues may need to be considered:

- Current or additional loadings that may impact stability (static and/or seismic loading conditions).
- Potential for liquefaction and foundation failure of the embankment if constructed over fine refuse.
- Potential for piping and/or excessive uncontrolled seepage discharge from the embankment or around the decant discharge pipe.
- Potential safety problems to miners in nearby underground active workings due to overburden breakthrough.
- Potential for excessive erosion along sloped surfaces with inadequate drainage control and vegetative cover.
- For impounding embankments, an inadequate combination of runoff storage and discharge capacity to accommodate the design storm.

Specific conditions that need to be evaluated relative to the modification of existing embankments include:

- Material Placement – The structural portions of embankment should be evaluated relative to shear strength and seepage characteristics.
- Foundation Preparation – The foundation preparation work undertaken prior to construction of the embankment and the potential for sliding along the embankment-foundation interface zone should be evaluated.

- Foundation Condition – It should be determined whether the embankment overlies soft natural soils or settled fine refuse that must be considered in static and seismic stability analyses.
- Piping Potential – It should be determined if existing seepage could lead to a piping failure.
- Underground Mining – It should be determined if the facility overlies abandoned or active mines, particularly ones with openings previously covered by coal refuse that could affect the safety of miners or cause environmental or property damage downstream.
- Drainage Facility – It should be determined if the existing drainage facilities will be structurally safe for expanded operation and will meet design-storm criteria.
- Site Boundary Constraints – It should be determined if physical restrictions (e.g., streams, rivers, mines, utilities, roads, railroads) and property boundary restrictions will limit the extent of any future modifications.
- Operations Capabilities – Existing equipment and manpower capabilities or engineering services (e.g., surveying or engineering support) should be evaluated for adequacy to implement expansion or abandonment plans or facility modifications

If an existing embankment exhibits unacceptable performance or is determined to be inadequate against a stability failure, the following modifications are appropriate:

- Sliding or inadequate factor of safety against slope failure – The slope can be stabilized by: (1) constructing a downstream buttress, (2) removing material from the top, or (3) flattening the slope. Of these options, constructing a downstream buttress is most effective in stabilizing a slope.

Downstream Buttress – A downstream buttress can be constructed using coarse refuse from normal disposal operations, and borrowed granular soil can be used for internal drainage control. Major limitations in constructing the buttress are physical or property limitations, poor access to the base of the embankment, inadequate supply of coarse refuse to accomplish buttress construction in a reasonable period, and extremely poor foundation conditions in the area of the buttress requiring excavation. Inclusion of drains within the buttress section of the embankment can be very effective in improving the stability of existing embankments. As illustrated in [Figure 6.10a](#), a drain can be placed as a granular blanket over the downstream face of an existing embankment and then covered with coarse refuse to form a buttress.

Removal of Material from Top – Although this alternative improves slope stability, it is often not practical to remove material from the top of the slope because of the resulting effect of the overall embankment configuration. Also, the cost of removing the material and disposing it at a different location often makes this alternative unattractive. This disadvantage can be partially overcome if the excavated material can be used to construct a buttress at the toe of the slope, additionally enhancing stability.

Flattening of the Slope – This alternative increases the stability of a non-impounding facility, but it is often not suitable for an impounding embankment constructed by the upstream method. The removal of material reduces the thickness of the structural section of the embankment and may lower the factor of safety. Also, the cost of removing material and disposing it at a different location often makes this alternative unattractive. This disadvantage

can be partially overcome if the excavated material can be used to construct a buttress at the toe of slope.

- **Phreatic Level Reduction** – If high phreatic surface conditions in the embankment contribute to an undesirable factor of safety, it is normally possible to lower the phreatic surface by: (1) installing horizontal drains and (2) reducing seepage.

Horizontal Drains – One means for providing internal seepage control in an existing embankment is by drilling horizontal drains beyond the phreatic surface to intercept the seepage, as shown in [Figure 6.10b](#). The design requirements and construction techniques for such drains are discussed in [Section 6.6.2.3.5](#). The installation of horizontal drains is often very effective. However, the unknown and potentially variable nature of coal refuse introduces greater risk that the drains will not meet expectations. If horizontal drains are employed, concurrent monitoring of their effectiveness should be performed. Extra drains should be added, or the existing drains should be supplemented with other drainage improvement methods, if conditions warrant. Normally, considerable monitoring of pore pressures conditions is required for evaluation of drain system effectiveness.

Reducing Seepage – It is normally possible to reduce the level of seepage by sealing the surface of the upstream face of an impounding embankment. The major disadvantage of this alternative is that the magnitude and rate of improvement is difficult to predict. A “wait-and-see” approach can be taken if the existing factor of safety is not critical on a short-term basis. If the impoundment configuration permits, shifting of the fine refuse discharge point to aid in sealing of the upstream face of the embankment and to force the pool toward the back of the impoundment has been found to be effective in reducing seepage.

- **Potential for Piping** – The most common measure for reducing the potential for piping of embankment material in a seepage zone is to provide a granular filter around the discharge location so that water can escape without carrying additional fines. Often this measure is coupled with construction of a buttress with a filter zone between the existing embankment and new buttress material, as discussed above and illustrated in [Figure 6.10a](#). The way to minimize the potential for piping is to prevent any past piping from extending into the new construction. Geophysical exploration may be useful for identifying voids. If a void is present, the designer must determine whether a filter system will be adequate and, if not, eliminate the void by a technique such as grouting.
- **Erosion Control** – Erosion control can often be achieved through relatively minor regrading and planting of vegetation or use of vegetative mats (erosion control blankets). If an existing slope is too steep, regrading the surface to provide horizontal benches can be effective.

6.3.6 Other Impounding Embankments

Other impounding embankments at mine sites include fresh water impoundments, sedimentation ponds, and treatment ponds. The primary distinctions between these structures and slurry impoundments are: (1) the size of the embankment is usually smaller, with the width and height designed to make efficient use of borrow material, typical of an earthen dam; (2) earthen borrow materials that are not part of the on-going disposal operation are typically used for embankment construction; (3) a permanent water pool level is maintained for fresh water impoundments and treatment ponds,

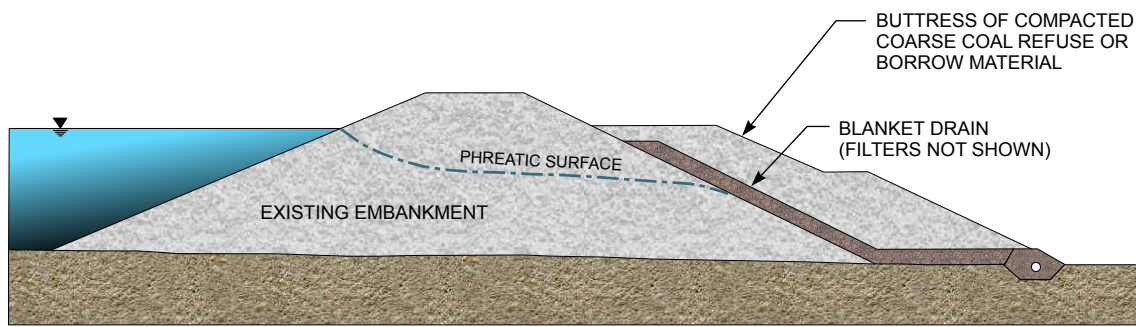

6.10a BLANKET DRAIN ON EXISTING SLOPE

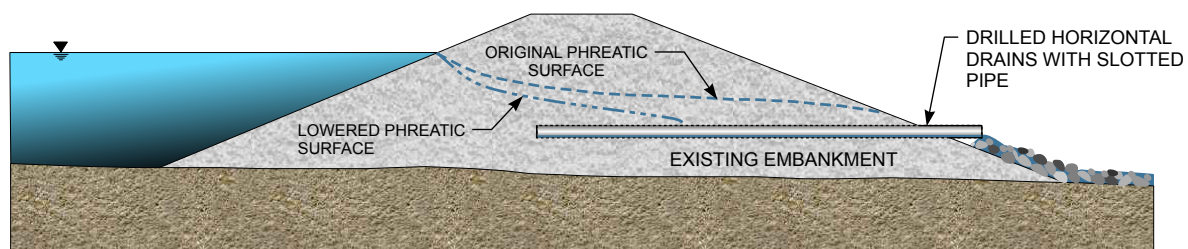

6.10b DRILLED HORIZONTAL DRAINS

FIGURE 6.10 INTERNAL DRAINAGE SYSTEMS FOR EXISTING IMPOUNDING EMBANKMENTS

resulting in steady state seepage conditions; (4) water pool level fluctuation within a sedimentation pond is usually over a limited range, with normal levels maintained at a low level; and (5) without the presence of fine coal refuse slurry, the pool level is typically in contact with the upstream face of the dam and thus is a source of seepage through the embankment. These geotechnical design considerations are important in the application of this Manual to projects with impoundments used for other than the disposal of coal refuse slurry.

The following geotechnical considerations apply to fresh water impoundments, sedimentation ponds, and treatment ponds:

- **Seepage control** – Internal drainage systems and foundation cutoff systems to prevent seepage from impacting the structural zone or toe of the embankment may be needed. Foundation treatment and a liner system may be needed. Impoundments that maintain a significant water pool depth impose greater hydraulic gradients on the embankment, potentially requiring more seepage control. Internal drains for these structures should have aggregate filters in order to comply with the federal dam safety practices discussed in [Section 6.6.2.3](#). Additionally, the initial filling of such impoundments should be monitored closely for evidence of seepage or other distress, as many dam incidents and failures have occurred under these conditions.
- **Slope stability** – Static slope stability is maintained by a structural embankment constructed of borrow material, with significant attention given to foundation conditions. Seismic stability and deformations are most critical where loose foundation conditions are present, as the embankment materials are usually designed to be well

compacted and not subject to strength degradation. Sloughing and erosion considerations may be more critical than encountered for slurry impoundments because slopes may be steeper and the water pool level may fluctuate significantly. Fresh water impoundments may impose stresses on the impounding embankment due to rapid drawdown of the reservoir.

- Drainage and outlet structures – Structural foundations and excavation slopes are required for diversion channels, principal and emergency spillways, conduits and other auxiliary structures. Most fresh water impoundments incorporate outlet structures that allow emergency drawdown of the reservoir. Control of seepage along conduits should be a point of emphasis. Many dam failures have been caused by internal erosion due to excessive seepage through poorly compacted backfill around conduits.
- Underground mines – Stability, sealing of mine openings, and infiltration into underground mine workings are concerns. Considering the hydraulic pressures imposed by a fresh water dam, sites with shallow underground mine workings may not be feasible or may require significant remedial measures.

Several design references are available for earthen dams used for fresh water, sedimentation control, and treatment: USBR (1987a); USBR (1992a); Bigatel et al. (1999); NRCS (2005b).

6.4 SITE GEOTECHNICAL/GEOLOGICAL EXPLORATION

Although the characteristics of foundation materials have been discussed in general terms, specific properties required for the design of a disposal facility can be determined only by conducting surface and subsurface geological explorations at the site. The type and extent of explorations to be conducted will depend upon the size of the planned embankment, the complexity of the site geology, the nature of the foundation materials, the specific function of the facility, and, most importantly, whether or not the embankment will impound water. In general, a comprehensive site evaluation and exploration program for a coal refuse disposal facility comprises the following tasks:

1. Review of available topographic maps, geologic soil survey and mine maps, satellite imagery, and aerial photographs of the site and the surrounding area.
2. Surficial geological and geotechnical reconnaissance of the site.
3. Identification of data needs for design, such as topographic maps, mine void locations, and soil, rock and refuse properties.
4. Preparation of a site investigation plan using compiled information to develop a site-specific strategy addressing exploration methods and locations, sampling and in-situ testing requirements, and contingency activities based on anticipated and possible unanticipated subsurface conditions.
5. Conducting a subsurface exploration program consisting of a combination of borings, test pits, in-situ testing and geophysical surveys.
6. Installation of monitoring systems such as piezometers, monitoring wells, and surveying monuments, particularly for exploration at existing facilities.
7. Comparison of sample descriptions to anticipated conditions. Laboratory index testing (i.e., particle-size distribution, Atterberg limits and moisture content) should be performed on the samples to confirm visual classifications.
8. Preparation of subsurface profiles based upon results from the field exploration and laboratory index tests and review of these profiles relative to the initial site investigation objectives and expectations.

9. Selection of samples for performance testing and development of engineering properties for facility design from test results.
10. Laboratory performance testing and verification of the results using correlations with the index test results. If performance test results are inconsistent with the index test data, the inconsistency should be resolved (e.g., performance testing of reserve samples or additional field exploration to obtain replacement samples for testing).
11. Interpretation of performance test results, comparison to anticipated conditions, and selection of engineering properties needed for design.
12. Preparation of facility design, considering constructability issues, with identification of construction-phase exploration and testing requirements to confirm critical performance parameters.

The sequence and potentially iterative nature of these steps are summarized in the flow chart presented in [Figure 6.11](#).

The preceding 12-step procedure is a suggested guideline for developing a thorough and cost-effective field exploration and testing program. The effort required for each of the listed steps will vary. Experience with similar geotechnical conditions will facilitate the development of the site exploration program. Each site exploration program must be sufficiently complete to provide the data required for a geotechnical evaluation of the site and design of the coal refuse disposal facility.

6.4.1 Background Data Sources

In planning a refuse disposal facility and in the initial site explorations, much useful information can be obtained from topographic, geologic and mine maps; agricultural soil surveys; satellite imagery and aerial photographs; and publications available from various government agencies. In addition, information from past investigations and area mining plans may also be searched to augment the information from public agencies. While typically not of sufficient detail for design purposes, these resources are readily available and represent an inexpensive source of valuable planning information.

6.4.1.1 Topographic Maps

Topographic maps are a vital source of information for planning a disposal facility and many published and on-line sources are available. The most important source is the series of standard topographic maps of the U.S. published by the U.S. Geological Survey (USGS). These maps cover quadrangles of 7.5 minutes of latitude and longitude at a scale of 1:24,000 (1 inch = 2,000 feet). More than 55,000 7.5-minute maps are available covering the 48 contiguous states. Other scales and areas of coverage are available from older map series or from other agencies. These topographic maps show the variation of ground surface elevation using contours (i.e., lines of constant elevation). The contour interval (elevation difference between adjacent contour lines) depends upon the scale of the map and the steepness of the terrain. In the Eastern United States the contour interval is usually 10 to 20 feet. In the western mountains, the contour interval is more commonly 50 feet. USGS topographic maps also show cultural and man-made features (roads, dams, buildings and political boundaries), water features (lakes, rivers and canals), wooded areas and areas of past mining activity.

Topographic maps are useful for investigating an existing disposal facility, even though it may have been developed subsequent to the topographic mapping. Comparison of the original topography with the existing condition can provide an insight to the history and development of the site. Knowledge of the topography of the surrounding area is important in planning the expansion or abandonment of an existing disposal facility.

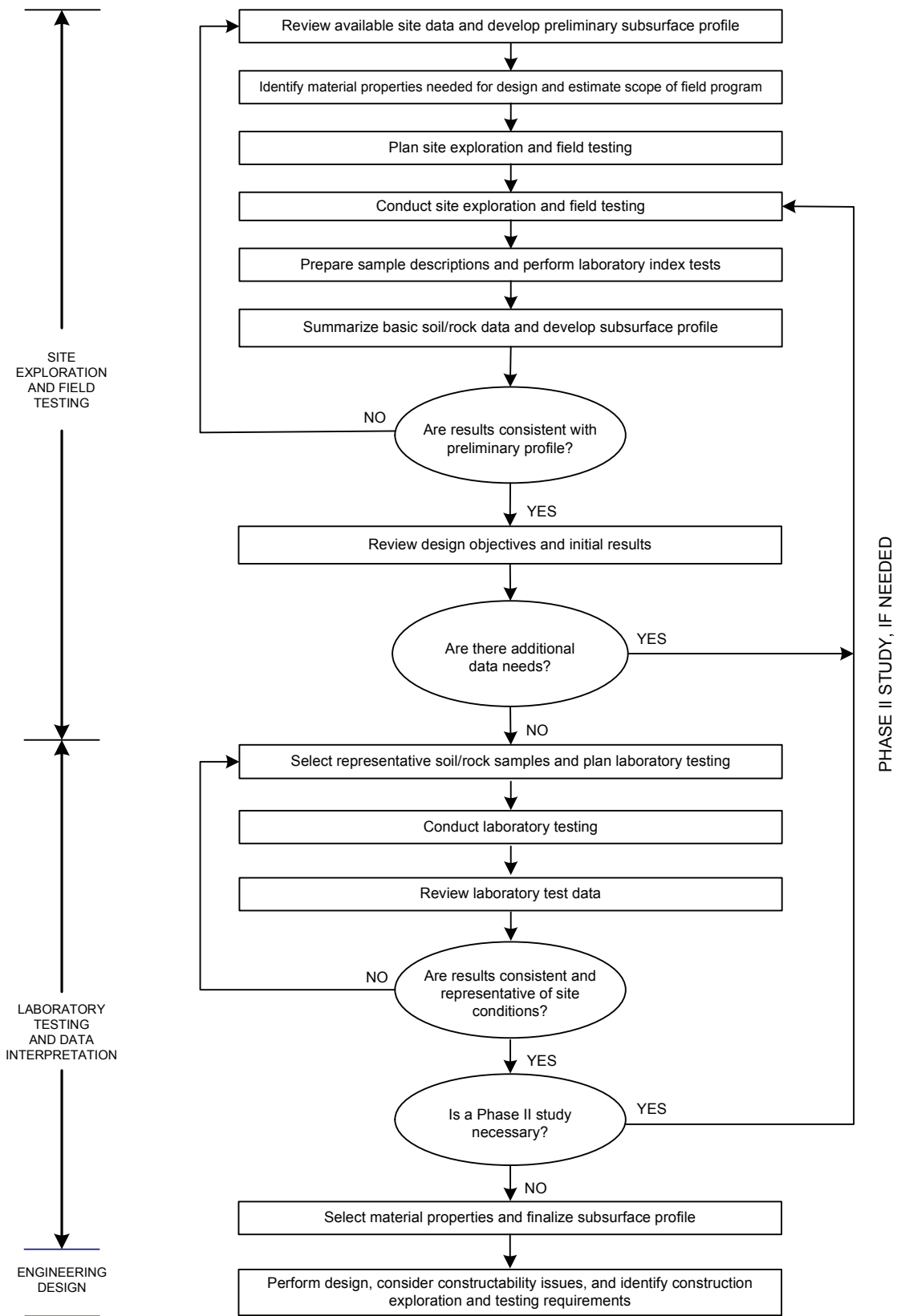

(SABATINI ET AL., 2002)

FIGURE 6.11 FLOW CHART FOR SITE EXPLORATION, MATERIAL PROPERTY TESTING AND FACILITY DESIGN

Another resource is USGS's The National Map web site, a framework for geographic knowledge of the U.S. that provides public access to high-quality, geospatial data and information. The site allows users to access, integrate, and apply geospatial data at global, national, and local scales. It includes a variety of information layers such as boundaries, elevation, geographic names, geology (global seismic networks, and real-time earthquakes), hydrography (real-time gauging stations and wetlands), imagery, land use and land cover, natural hazards (climate and hurricanes), and topographic maps that may be useful to designers.

6.4.1.2 Geologic Maps and Publications

Geologic maps of a proposed disposal facility site and surrounding area can provide valuable engineering information. These maps are prepared by the USGS or by state geological surveys and generally show ground surface outcrops of various rock units using a color code and letter symbols. Geologic maps usually have a column identifying formations and corresponding symbols and one or more geologic sections depicting the regional structure of the rock, identifying the rock units and providing a description of the units and their characteristics. To be most useful for evaluation of individual disposal facility sites, a geologic map should preferably have a scale no larger than the USGS topographic map of the area. Only a small part of the United States has been mapped in this detail, however, and it is often necessary to use maps covering up to several hundred square miles. Geologic maps can be valuable in the initial investigation and evaluation of a site, but proper interpretation of these maps requires knowledge of the fundamentals of geology and an understanding of how geologic information can be used in planning and design.

Specific regional and local information on geologic conditions should also be considered. For example, in steep Appalachian Valleys, joints and fractures from stress relief can affect excavation and abutment stability and impoundment seepage control. Reports on physiography published by the USGS (e.g., Wyrick and Borchers, 1981) can provide insight for planning exploration programs. Furthermore, weathered joints and fractures encountered in eastern Kentucky and southern West Virginia, sometimes referred to as "hillseams," can represent critical foundation or abutment features, and mining publications may be helpful in planning associated with site preparation (e.g., Sames and Moeb, 1989). Additionally, local mining and highway construction experience should be sought, as it can disclose information on bedrock structure and fracture conditions that may influence development plans. Perin (2000) presents a case study that demonstrates the use and limitations of geologic publications, mapping, and exploration for a refuse disposal site in eastern Kentucky.

The USGS provides access to a wealth of information resources including maps, reports, publications, and links to related web sites. Resources of possible interest for refuse disposal planning and design at the time of publication include:

- [USGS Library](#) – Access to over 300,000 book, map, and serial records in the USGS Library online catalog.
- [USGS Store](#) – Source for USGS maps and books, as well as products from other agencies.
- [Publications Warehouse](#) – Search engine for 67,000 bibliographic citations.
- [Geologic Information](#) – National clearinghouse for geologic maps, datasets, and related geoscience information with links to USGS geoscience databases and programs and resources for creating digital geologic maps.
- [National Water Data – NWISWeb](#) – Comprehensive gateway to water-resources data throughout the U.S.
- [National Atlas of the United States®](#) – Comprehensive collection of small-scale geospatial data from federal agencies.

- geodata.gov – Web-based portal for access to maps, data, and other geospatial services from across all levels of government.

6.4.1.3 Agricultural Soil Surveys

Much more widely available than large-scale geologic maps are soil surveys prepared by the Natural Resources Conservation Service (NRCS). A soil survey is a detailed report on the surficial (i.e., upper 5 to 6 feet) soils of a specific area. Soil surveys typically have maps showing soil-type boundaries and photographs, descriptions of soil characteristics, and tables of soil properties and features. The tables section of a soil survey report provides information on soil properties including engineering index properties, physical and chemical properties, and soil and water features. The tables section also has information on soil use, such as crops and pasture, recreation, and engineering. Although data from these surveys are generally not suitable for design analyses, the surveys are valuable tools for initial site reconnaissance studies and for planning detailed field explorations. Printed soil surveys can be obtained from NRCS regional offices or local soil conservation district offices. Surveys are also available from the NRCS web site.

6.4.1.4 Satellite Imagery, Aerial Photographs and Other Imagery

Aerial and satellite photographs and other imagery can be extremely valuable in the investigation and evaluation of a proposed or existing disposal facility site because they reveal much natural and man-made detail that may not be apparent from the ground, no matter how carefully ground reconnaissance is carried out. Also, these data can be used with Computer-Aided Design and Drafting (CADD) and Geographic Information System (GIS) software to provide informative representations of site conditions.

Data and imagery from satellites and aerial reconnaissance flights are increasingly being utilized for site exploration and characterization purposes. These data are available from commercial vendors as well as state and federal government agencies. At the time of publication of this Manual, satellite images are available to the public at a resolution of as small as 2 feet and aerial photographs can be obtained with a resolution of as small as 6 inches. An important use of satellite imagery and aerial photographs is the performance of terrain analysis and lineament studies for identification and location of surface features that are expressions of discontinuities in the underlying bedrock. Such features may reflect bedrock joint/fracture zones that warrant additional focus during exploration programs for impoundments or that require assessment of the potential for breakthrough potential to underground mines.

Photographs represent only a portion of the information available. Sophisticated sensors on satellites and sensory equipment that can be mounted on airplanes can provide a spectrum of light band information that when analyzed in combinations with sophisticated software allow identification of various surface characteristics. Interpretation of these data is referred to as remote sensing, and some applications include classification of land usage, classification of surface cover types, identification of stressed vegetation or tree canopy, and delineation of surface thermal variations.

Some satellite systems that currently (2009) generate data that might be used in site exploration and reconnaissance studies and for preparation of site drawings and figures include:

- Landsat
- IKONOS
- SPOT
- OrbView-3
- QuickBird
- ASTER
- EO-1

There are many forms of satellite data and many vendors that can provide satellite data packages. These data providers can be identified most easily from an Internet search. Also, a wide range of information can be gathered from custom-designed aerial surveys. The types and quality of data available and the associated costs should be carefully reviewed prior to purchase of data or contracting for such data to be obtained.

Generally aerial and satellite imagery data are available or can be obtained in an orthorectified format, which means that the positions of all the data in the photograph or image are accurately located with respect to a known coordinate system. Thus the data can be input to a GIS-based system and automatically shown in true relationship to other orthorectified data such as site boundaries, features, structure, and infrastructure. The USGS through its Earth Resources Observation and Science (EROS) center provides a wide range of such data, some of which can be obtained without charge.

Digital Raster Grids (DRGs) for some parts of the country can be downloaded free from the Internet and printed, and these are generally identical to USGS topographic sheets. They are frequently used as bases for CADD drawings, but they are not attractive for GIS applications because the various types of data shown (e.g., contours, roads, structures, shadings) are combined into a single layer.

Aerial photographs corresponding to USGS quadrangles (referred to as Digital Orthophoto Quadrangles or DOQs) are also frequently used as bases for CADD drawings where proposed construction or property boundaries are shown over a photographic base. They can be used in a similar manner in GIS-based software where individual layers representing roads, structures, utilities, etc. are displayed over a photographic base. Also available are Digital Orthophoto Quarter Quadrangles (DOQQs), which are orthorectified quarter-quadrangle (7.5-minute coverage) photographs.

Digital Elevation Model (DEM) data can be used to generate elevation contour maps of a site. DRG and DEM data can be combined in GIS-based software to generate three-dimensional models of USGS topographic sheets.

The above data can be obtained from the USGS, and some states provide extensive data free over the Internet. Pennsylvania, for example, provides 7.5-minute DRGs (also available with the surrounding border cropped off), DOQs, DOQQs and DEMs for the entire state. Other information such as coal mine maps and environmental data may be available from state web sites.

Soil-type data are available for some parts of the country in digital, orthorectified form suitable for use in GIS-based software.

These sources of aerial and satellite photographic data are increasingly available in an orthorectified (also referred to as georeferenced) format for input to GIS-based software where they can be automatically displayed in accurate relationship to other georeferenced site data. The reliability, availability and costs of various types of data should be carefully evaluated when planning site drawings and pictorial displays.

6.4.1.5 Past Investigations and Area Mining Plans

Information from past investigations and old mine plans in the vicinity of a planned or existing operation can provide valuable information for planning and preliminary design of a new facility. Particularly valuable are maps of past or planned future mining, as well as geologic information on bedrock structure, jointing and fracturing. As discussed in [Section 8.2.1](#), mine maps are available at state agencies (e.g., Virginia Department of Mines, Minerals and Energy; Kentucky Department of Mines and Minerals; West Virginia Office of Miners' Health, Safety and Training; Illinois State Geological Survey) and from MSHA and the Office of Surface Mining (OSM). MSHA district offices maintain

maps until a mine closes and OSM stores a copy of the final map after closure at the OSM National Mine Map Repository in Pittsburgh, Pennsylvania. Additional information related to sources and availability of mine maps is presented in Chapter 8.

Underground mine maps can be used to locate mine features with respect to the surface or other underground mines and to determine the dimensions of pillars and mine openings (Shackleford, 2000). Information typically provided on underground mine maps includes (NRC, 2002):

- Pillared, worked-out, and abandoned areas, pillar locations, sealed areas, future projections, adjacent mine workings within 1,000 feet, surface or auger mines, mined areas of the coalbed, and the extent of pooled water.
- Dates of mining, coal seam sections, and survey data and markers.
- Surface features, coal outcrop, and 100-foot-overburden contour or other prescribed mining limit; mineral lease boundaries, surface property or mine boundary lines, and identification of coal ownership.

The accuracy and completeness of underground mine maps varies due to the age and non-uniform standards followed in their development. For example, there are significant limitations to some maps, particularly those for abandoned mines and mines operating before 1969. In addition, the horizontal and vertical (overburden) distances between mined barriers and an impoundment may not be accurately shown. Designers must consider these factors and the resulting impacts in using mine maps for refuse disposal planning and design in the vicinity of active or abandoned mines. Compounding the problem, some maps and records of older mines have been lost or destroyed. Therefore, to confirm map accuracy, site exploration using the geotechnical and geophysical exploration methods described in this chapter may be needed. Sections 8.2 and 8.3 present references and information to assist in locating available mapping and confirming its accuracy.

6.4.1.6 Individual Site Mapping

For most disposal facility sites, site mapping should be performed before planning reaches the design phase. Usually mapping is accomplished using low-altitude, large-scale aerial photography to develop detailed, large-scale topographic maps. The topographic maps can be produced at the scale and contour interval required for final site planning and design. Aerial topographic maps typically have contour intervals of one or two feet for relatively flat terrain and as much as 5 to 10 feet in steeper terrain.

For geographic areas of the size associated with most disposal facility sites, the major cost of obtaining aerial photographs is that of the aircraft. Therefore, it costs very little more to photograph areas adjacent to the anticipated site. This allows flexibility in making final plans and provides additional data for interpreting site conditions that may affect the facility design.

6.4.2 Surficial Reconnaissance and Geologic Mapping

The available topographic and geologic maps, aerial photography, and other documentation that pertain to the site should be supplemented by a surficial reconnaissance and geologic mapping, which consists of walking the disposal facility site and vicinity and observing topography, rock outcrops, mine openings, soil types, vegetative cover, spring discharges, perennial and intermittent watercourses, and any other features that may be relevant to the planned use of the site. This type of site reconnaissance generally requires a geologist or engineer who is familiar with refuse disposal and embankment design and who can recognize the significance of the observed features. If possible, reconnaissance should be conducted during times when vegetation is dormant so that site features are more visible.

Consideration should also be given to conducting the reconnaissance shortly after rainfall so that spring and flow channel conditions that may be relevant to the design can be observed.

The elevation of the site should be compared to known or correlated elevations of mineable coal seams in the vicinity. The site reconnaissance should include a search for evidence of past mining, including but not limited to mine entries, sinkholes, highwalls, haul roads, spoil piles, discolored seepage or watercourses, and areas with no vegetation or distressed vegetation. The presence of any oil and gas wells, pipelines, and other underground or overhead utilities should be noted.

Rock outcrops should be observed for lithology, bedding, and structure. Structural observations include strike and dip of strata, fracture orientation and spacing, and observable folds and faults. Where weathered joints and fractures are encountered, in-fill materials and widths should be recorded. Relatively recent fracturing should be noted as it may be indicative of subsidence. Bedding observations include thickness, sedimentary structures (e.g., planar bedding, cross bedding), and lateral continuity. Distinctive or known marker beds, such as coal seams or other persistent strata such as limestone or dolomite should be noted. Lithologic observations (e.g., color, grain size, mineral presence, weathering, and hardness) should also be noted.

Soils should be observed with respect to density, grain size, stiffness, color, mottling, structure, organic matter, and depth. Slopes should be observed for evidence of recent or older landslides, including slumps, scarps, and bent tree trunks. Mine rock waste (spoil) piles or other conditions related to previous mining such as cliffs, strip pits or ponds should be noted. General vegetation type and density should also be observed and documented.

Surficial reconnaissance may be supplemented by test pits or shallow, hand-augered borings to provide samples for basic laboratory tests for soil classification. Test pits excavated to rock may help disclose bedrock types, coal seam outcrops, and overburden jointing or fracturing. A careful surficial reconnaissance and accompanying tests can produce data sufficient for a preliminary surficial map of a refuse disposal facility site. However, as with any exploration program, it should be recognized that undetected subsurface conditions are a risk, and reasonable contingencies should be considered in the development of designs.

6.4.3 Subsurface Exploration and In-Situ Test Planning

After available information has been collected and evaluated, the designer can begin planning a program for subsurface exploration and in-situ testing. The field exploration methods, sampling requirements, and types and frequency of field tests to be performed should be determined based on project design requirements, geologic conditions, the availability of existing subsurface information, the availability of equipment resources, and local practice. ASTM D420, "Standard Guide to Site Characterization for Engineering Design and Construction Purposes," provides general guidelines for site reconnaissance, exploration planning, equipment and procedures, geophysical exploration, sampling, material classification, in-situ testing, interpretation and reporting.

An overall field exploration and in-situ testing program for obtaining the data needed to define subsurface conditions and perform engineering analyses and design should be developed. Once the field exploration and testing begins, the program may need to be modified in response to site access constraints (e.g., steep terrain may not be accessible to the available drilling equipment) or to address variations in subsurface conditions not anticipated during exploration planning.

Site exploration programs are often conducted in phases. To obtain an overview of the geological issues that can affect a facility, remote sensing, geophysical exploration and widely-spaced geotechnical sampling and testing may be conducted as part of an initial phase. During a second or subsequent

phase, localized disturbed and undisturbed sampling and in-situ testing may be conducted to obtain more detailed information for defining geologic features and for determining geotechnical engineering properties for design. The types of subsurface exploration and testing activities in the typical sequence in which they are conducted are:

- Remote sensing
- Geophysical investigations
- Test pits
- Disturbed sampling
- In-situ testing
- Undisturbed sampling

Remote sensing data can be used to identify terrain conditions, geologic formations, escarpments and surface reflection of faults or highly-jointed bedrock zones, buried stream beds, site access conditions and general soil and rock formations. Remote sensing data from satellites (e.g., Landsat images from NASA), aerial photographs from the USGS or state geologic surveys, and data from commercial aerial mapping services may be useful. The designer should be familiar with the use of such data, including limitations.

Geophysical methods offer another means for characterizing subsurface conditions. Geophysical methods can be used for general site characterization, mapping abandoned mine workings and measuring physical properties in boreholes at coal refuse disposal facilities. For general site characterization, geophysical methods can be used to determine the depth to bedrock, map ground stratigraphy, detect sudden changes in subsurface formations, assess the rippability of bedrock, and map variations of physical properties within coal refuse and groundwater. Surface techniques such as electrical resistivity, ground penetrating radar (GPR), electromagnetic conductivity (EM) or seismic refraction can be applied. These techniques may be useful in defining broad variations in the subsurface, but boreholes are needed for verification and interpretation.

Some geophysical methods can be used for detection of abandoned workings or cavities in karst formations from the surface. For this purpose, the most commonly considered geophysical techniques (although only recently applied at refuse impoundment sites) include electrical resistivity, seismic reflection and gravity. The success of these techniques depends on the depth to the mine workings, degree of flooding, and thickness of the coal seam. Downhole geophysical methods can define vertical variations in physical properties. In particular, crosshole and downhole seismic tests induce mechanical waves within the ground mass to provide information on the dynamic elastic properties including the shear (S) wave velocity required for seismic site amplification studies of ground shaking and for soil liquefaction evaluations. The application of surface and borehole geophysical methods suitable for siting and engineering evaluations of refuse disposal sites is presented in [Section 6.4.4](#).

Test pits are small excavations dug to a depth of 10 to 15 feet (i.e., to the typical reach of an excavator or to refusal in rock). Compared to other exploration methods, test pits are more efficient because they can provide information about a relatively large area inexpensively, and they expose a large amount of soil for detailed examination by the field geologist or engineer. Because the side walls of a test pit can collapse rapidly, field personnel should not climb into a hole deeper than about four feet without assessment of soil stability and use of shoring, as appropriate. The locations for test pits are typically selected in the field as the site investigation program progresses. Test pits are generally used to supplement data between borings or to explore areas where only near-surface conditions are important, such as potential source areas for borrow material. The use of test pits for geologic mapping and material sampling is discussed in [Section 6.4.3.3](#).

Disturbed samples can be used to determine soil type, gradation, classification, water content, consistency, relative density, and stratification. The samples are considered to be disturbed because the sampling process modifies their natural structure. Disturbed samples are typically obtained using track- or truck-mounted augers and other rotary-drilling techniques. The most common disturbed sampling method is the Standard Penetration Test (SPT), which is performed using a split-barrel sampler during the drilling of geotechnical borings. Geotechnical borings allow: (1) testing as drilling progresses and recovery of samples, (2) measurement of groundwater levels and collection of groundwater samples, and (3) installation of instrumentation for monitoring the groundwater level or the deformation of the soil and rock at any depth. In planning an investigation, boring locations should be selected so as to optimize the amount of useful data from the drilling program. The basis for choosing boring locations and procedures for drilling borings is discussed in [Section 6.4.3.1](#).

Other in-situ test and geophysical methods can be used to supplement soil boring data. For instance, the cone penetrometer test (CPT), also referred to as the cone penetration test, provides information on subsurface soils without sampling. Stratigraphy and strength characteristics of soils can be determined as the cone penetrometer is advanced. In-situ methods are most effective when they are used in combination with conventional sampling to reduce the cost and the time required for field work. Data from these tests can be correlated with sampling and testing data obtained by conventional means.

Undisturbed samples are obtained for laboratory testing when determinations of the in-place strength, compressibility (settlement), natural moisture content, unit weight, or hydraulic conductivity are needed. They also allow observation of discontinuities, fractures and fissures associated with subsurface formations. Although the sampling equipment is designed to minimize disturbance and these sample types are designated as “undisturbed,” in reality they are disturbed to some degree. The degree of disturbance depends on the type of subsurface materials, type and condition of the sampling equipment used, the skill of the drillers, and the storage and transportation methods used.

6.4.3.1 Program Planning

The number and depth of borings and locations of in-situ tests required for a particular subsurface exploration program will depend on the size of the disposal facility site, the nature and uniformity of the site geology, the magnitude of loads to be applied to the natural materials, the groundwater conditions, the presence of past or active underground mining in the vicinity of the embankment, and the complexity of the facility design. For example, explorations for new impounding embankments normally require significantly more borings than those for non-impounding embankments.

The appropriate depth and spacing of borings is difficult to generalize because they depend upon site conditions and disposal facility plans. An exploration program for a specific site should provide sufficient information for identifying, delineating and correlating geologic and soil conditions for designing a safe and environmentally acceptable disposal facility. Often the final location of borings and in-situ test sites must be determined in the field, or additions must be made to the boring program based upon evaluation of the initial data obtained. Excavation of test pits should be considered as a means for supplementation of the boring program. Test pits facilitate examination of shallow subsurface conditions and the recovery of bulk samples.

The spacing and number of borings beneath a dam depends on the complexity of the geology. Some of the more important factors to consider are the character and continuity of the beds, elevation of the strata, presence or absence of joints or faults, and proximity to previous underground mining. The depth, thickness, sequence, extent, and continuity of the various strata should be determined.

USDA (1978) guidance on exploratory borings for fresh-water dams includes the following:

- Centerline of Dam – Minimum of one boring on each abutment and at the outlet structure transect, plus one boring at any abandoned stream channel, plus additional borings for correlation of strata. Boring depths should not be less than the height of the dam unless unweathered rock is encountered and is not underlain by compressible strata or mine workings.
- Outlet Conduit – In addition to the boring at the transect with the centerline of the dam, borings should be located at the vertical riser intake, downstream toe of the dam, outlet of the conduit, and additional locations as needed to define the rock surface. Boring depths should not be less than the height of the backfill over the conduit or 12 feet, whichever is greater, unless unweathered rock is encountered. At the riser intake, the depth should not be less than the planned height of the riser above natural ground or 12 feet, whichever is greater.
- Emergency Spillway – Geologic cross sections based upon three or more borings should be developed at the control section, intake section, and outlet section with additional borings at cross sections as needed for correlation and location of strata contacts and identification of excavation materials. Borings should extend to a depth not less than 2 feet below the bottom of the proposed spillway.
- Foundation Drain – Carefully-logged borings at the centerline of the dam and toe may provide sufficient information, although additional borings or test pits may be necessary where subsurface conditions are highly variable.

Tables 6.15 and 6.16 present guidelines for typical subsurface exploration and in-situ testing programs for new disposal facilities both with and without impoundments. The exploration program to be used for a particular disposal facility and the associated in-situ testing must be developed by a qualified geotechnical engineer familiar with the requirements of the proposed facility. If inadequate data are obtained from the initial boring program, additional borings and/or test pits should be advanced to supplement the original boring data.

An in-situ testing program typically involves SPTs obtained during boring advancement and unconfined compression tests on recovered split-barrel samples performed by field personnel using pocket penetrometers or field torvane equipment. Where soft sediments or fine coal refuse are critical to embankment stability, CPTs provide an effective method for characterizing the consistency and strength of the material. In-situ testing also generally includes hydraulic conductivity testing performed in soil and rock to assess foundation conditions in valley bottom and abutment areas. Installation of piezometers in completed borings can facilitate field hydraulic conductivity testing as well as site groundwater characterization.

Table 6.17 presents guidelines for a typical subsurface exploration and in-situ testing program for an existing disposal facility. Similar to a new disposal facility, the in-situ testing program for an existing disposal facility and the interpretation of subsurface data must be performed by a qualified geotechnical engineer familiar with the facility design parameters. For an existing disposal facility, borings are normally required when it is suspected that the embankment factors of safety are low or when expansion of the embankment is planned, as discussed in Section 6.3.4, and some of the information indicated in Table 6.17 may already be available from previous plans. The subsurface exploration and in-situ testing program is greatly influenced by site conditions, the disposal facility hazard potential, the type of disposed refuse and its current condition, the stage of facility development, and the extent of records of previous construction and placement of materials. Often, the in-situ testing program will be designed to obtain the same information relative to the underlying foundation materials that would be required for a new disposal facility. Extensive data relative to the materials and quality of construction of the existing embankment must generally be obtained.

TABLE 6.15 GUIDELINE SUBSURFACE EXPLORATION PROGRAM FOR A NEW IMPOUNDING EMBANKMENT

Location	Guideline Exploration Program
Abutments	One boring (minimum) should be drilled in each abutment to the maximum extension of the embankment, to the depth of the valley bottom, or to a depth where the boring will overlap geologically with adjacent borings. Multiple borings may be required in each abutment depending on the length of the dam and complexity of the geology.
Other locations	Additional borings, particularly for large embankments, beneath the structural portion of embankment with spacing and depth to provide sufficient overlap between adjacent borings to correlate data and to develop a geologic profile along the embankment.
Valley bottom or lowest portion of embankments not located in valley bottom	A least one and generally multiple borings should be planned beneath the critical structural portion of embankment. The depth of at least one boring should be approximately equal to the planned height of the embankment unless firm bedrock is encountered at shallower depth. Even if rock is encountered, deeper borings may be needed to sufficiently reveal ground water seepage/flow, to evaluate underlying deep mining, or for other special requirements. Test pits should be provided for the purpose of observing and documenting the continuity of shallow soil stratigraphy and for obtaining bulk samples.
Upstream and downstream of crest	At least one boring upstream and one downstream from valley bottom borings for correlating data and developing a geologic profile across embankment. The downstream boring should be near the toe of the embankment where slope stability is expected to be most critical. Borings should penetrate to at least softest layer to be incorporated in stability analyses and preferably into competent rock. Sufficient test pits to observe and document continuity of shallow soil stratigraphy and obtain bulk samples should be provided.
Decant/spillway structures	Borings and/or test pits along probable axes of structures to be founded on natural soil or soft rock should be planned and should be drilled to a depth at least equal to the width of the structures and preferably into very stiff soils or firm bedrock.
Embankment in vicinity of past mining	Unless available mine maps and other information confirm that underground mining is distant enough to preclude potential impacts to the embankment, borings should be drilled at locations and to depths necessary for assessment of the accuracy of the mine mapping and for determination of the potential amount of subsidence, the probability of additional subsidence, and the potential for mine breakthrough. Typically at least one boring (and to assess some subsidence and breakthrough situations, several borings are required) should be drilled to mine elevation to obtain a full profile of the overlying rock and to define the groundwater level in the mine. This is particularly important if the mine is located so that it could adversely affect embankment stability, or if the mine is still in use and water inflow from the impoundment could imperil the miners or the mining operation. Appropriate safety provisions should be taken, including wet drilling, with respect to the potential for encountering a potentially explosive gas mixture within the mine.
Impoundment area	Sufficient borings and/or test pits to observe and document continuity of shallow soil stratigraphy and obtain bulk samples in order to determine the potential for ground water impacts.
Borrow areas	Sufficient borings and/or test pits to characterize materials, estimate available volume, and obtain bulk samples.
General	Additional borings, as determined by a qualified engineer or geologist, to meet special requirements of planned disposal facility or to gain knowledge of special geologic factors affecting design.

6.4.3.2 Subsurface Exploration and In-situ Test Methods and Applicability

This section provides information on various subsurface exploration and in-situ test methods that are currently used for site characterization, sampling and determination of site-specific soil and rock properties for the design of coal refuse disposal facilities. Conventional subsurface exploration and testing programs typically include test pits, rotary drilling, SPTs, and disturbed and undisturbed sample recovery. In-situ testing methods described in this section include SPT, CPT, piezocone penetrometer test (CPTu), seismic piezocone penetrometer test (SCPTu), and vane shear test (VST). Additionally, borehole testing to measure hydraulic conductivity is typically conducted. Standardized test proce-

TABLE 6.16 GUIDELINE SUBSURFACE EXPLORATION PROGRAM FOR A NEW EMBANKMENT WITHOUT AN IMPOUNDMENT

Location/Condition	Guideline Exploration Program
Embankment toe	Sufficient borings and/or test pits should be provided near the planned location of toe to explore conditions where foundation material may have a lower strength than embankment material. Borings must extend past the depth where stability is a consideration and preferably should extend to competent bedrock. Where the depth to bedrock is less than 10 feet, test pits may be substituted for these borings.
Abutments	Sufficient borings and/or test pits should be provided to observe and document subsurface conditions where stability is a consideration and for planned excavations for diversion ditches or access roads.
Potential for ground-water impacts	If seepage through refuse may create an undesirable environmental condition, borings should be drilled sufficiently deep to identify the groundwater level. These borings will provide data for determining need for a drainage collection system and/or an impervious liner between the coal refuse and the underlying foundation. Often one or two additional borings and several test pits will need to be advanced at the general disposal facility site to determine groundwater conditions throughout the area that will be covered by refuse.
Embankment in vicinity of past mining	Unless available mine maps and other information confirm that underground mining is sufficiently distant to preclude potential impacts to the embankment, borings should be drilled to evaluate the potential effects of subsidence, the stability of the structural portion of embankment, the potential for breakthrough, or if leachates from facility could adversely affect groundwater quality in the mine.
Borrow areas	Sufficient borings and/or test pits should be provided to characterize materials, estimate available volume, and obtain bulk samples.
General	Additional borings, as determined by a qualified engineer or geologist, should be provided to meet special requirements of the planned disposal facility or to gain knowledge of geologic factors that could affect design.

dures for these in-situ testing methods have been developed by ASTM, and these are identified in the sections that follow. ASTM D 420, "Standard Guide to Site Characterization for Engineering Design and Construction Purposes," summarizes the various methods for site characterization. For in-situ test methods that do not have standardized ASTM procedures, references for additional details are cited.

Conventional subsurface exploration methods typically involve the retrieval of soil samples and rock core. Soil samples may be either disturbed (but representative) or undisturbed. Disturbed samples are those obtained using equipment that destroys the macro structure of the soil, but does not alter its mineralogical composition. Specimens from these samples can be used for determining the general lithology of soil deposits; for identifying soil components and general classification purposes; and for determining grain size, Atterberg limits, and compaction characteristics of soils. Undisturbed samples are obtained in cohesive or fine-grained soil strata for use in laboratory testing to determine engineering properties. Undisturbed samples of granular soils can be obtained, but specialized and costly procedures are required such as freezing or resin impregnation and block or core type sampling. The term "undisturbed" refers to the relative degree of disturbance to the in-situ properties of the soil. Undisturbed samples are obtained with specialized equipment designed to minimize the disturbance to the in-situ structure and moisture content of the soils. Specimens obtained by undisturbed sampling methods are used for determining the strength, soil layering, hydraulic conductivity, density, consolidation, dynamic properties, and other engineering properties. Common methods used to obtain disturbed and undisturbed soil samples are presented in [Table 6.18](#).

6.4.3.3 Test Pits

To evaluate materials near the ground surface and to supplement the information gained from the borings, test pits or test trenches are frequently employed. Test pits are usually excavated by a backhoe or bulldozer and can range from a few cubic feet to a few cubic yards in volume. In addition to providing

TABLE 6.17 GUIDELINE SUBSURFACE EXPLORATION PROGRAM FOR AN EXISTING EMBANKMENT

Location/Condition	Guideline Exploration Program
Embankment centerline	Typically, three or more borings should be drilled in a line perpendicular to embankment axis. Borings should extend to a depth below the phreatic surface in the embankment unless a water surface is not encountered for a depth significantly below that which could reasonably be expected to affect the stability of the embankment. Piezometers should be installed in selected borings to monitor the level of water surface within the embankment and foundation. Special efforts should be made to evaluate materials and water levels encountered as a function of depth within these borings to determine if horizontal impervious zones are present that could affect seepage through the embankment.
Downstream embankment face	A line of borings parallel to the axis of the embankment should be drilled to a depth below the phreatic surface. Normally these borings should be drilled in the downstream face of embankment where the phreatic surface level is most critical to stability. This location should be determined based on a profile developed from data from the first line of borings perpendicular to the embankment axis.
No information on foundation preparation or foundation stability is a concern	If no information is available relative to procedures originally used to prepare the embankment foundation or if the designer believes that stability along the existing foundation may be critical, at least one and preferably multiple borings should be drilled in the embankment axis and downstream face and should extend through the embankment and into competent rock.
Downstream valley bottom	At least one boring should be drilled at the highest section of embankment where stability is likely to be critical. Multiple borings may be required in this area if expansion of the disposal facility to a greater elevation is planned.
Facility expansion	Additional borings should be drilled at locations that will appropriately allow for analyses associated with enlarging the embankment, as determined by designer.
Settled fine refuse	If the embankment impounds settled fine refuse slurry and an expansion of the embankment over slurry is contemplated, borings should be extended into the slurry in order to obtain samples for laboratory testing. The exploration program may also entail the use of cone penetration testing and geophysical surveys. If the embankment was built using the upstream method, the extent to which fine refuse underlies the embankment should be determined by drilling borings and/or use of geophysical methods.
Embankment in vicinity of past mining	If past mining has been completed beneath any portion of the existing disposal facility, borings should be drilled at locations and depths necessary to determine the potential subsidence, the probability of additional subsidence, and the potential for mine breakthrough. Generally, at least one boring should be drilled to below the mine elevation to obtain a full profile of overlying rock and to define the groundwater level at the mine elevation. This is particularly important if the mine is located such that it could adversely affect the stability of the existing embankment or if the embankment impounds water and the mine is still in use (i.e., where water inflow from the impoundment could be unsafe to miners or mining operations). Appropriate safety provisions should be taken to prevent possible gas release through any boring drilled to an abandoned mine.
Decant/spillway structures	If changes in the existing disposal facility include plans for decant or spillway structures founded on soil, soft rock or refuse materials, borings should be drilled and/or test pits advanced along the probable structure axis to provide data for a sufficient depth to properly design foundations or bedding requirements.
General	The required boring program and any modifications should be determined by a qualified geotechnical engineer. Flexibility will be required on the part of the engineer because the boring program will frequently need to be modified as the field investigation proceeds in order to resolve issues arising from data obtained from earlier borings.

access to larger samples than possible from borings, test pits permit direct visual examination of the soil in place. In-situ density and field shear strength tests also may be conducted in test pits at various depths. Test trenches permit observation of lateral variations of soil conditions over the trench length. This may be particularly useful in residual soils produced by in-place weathering of rock where several degrees of weathering and initial rock quality may be present and in colluvial soils where large variations in gradation may be observed. If compressible cohesive soils are present, test pits can provide access for undisturbed sampling of soil blocks, as described in ASTM D 7015, "Standard Practices for Obtaining Undisturbed Block (Cubical and Cylindrical) Samples of Soils."

6.4.3.4 Boring Methods and the Standard Penetration Test (SPT)

A variety of drilling methods can be used for subsurface geotechnical exploration, including displacement, wash, and auger borings, and percussion drilling. Augering in soil and coring in rock are preferred because these methods permit recovery of representative samples for classification and testing. Depending on the terrain, either truck- or skid-mounted drilling rigs are used. Truck rigs are generally more powerful and drill faster, but skid rigs are more maneuverable in rough or heavily wooded terrain and are less difficult to mobilize.

For drilling in soil, augers ranging from 6 to as much as 18 inches in diameter are used. Soil samples can be obtained from: (1) the auger cuttings, (2) a split-barrel drive sampler (disturbed sample), or (3) a thin-walled tube (undisturbed sample). Usually, the boring is advanced by augering a set distance (2 to 10 feet) or until there is a change in soil layer, and either a split-barrel or thin-walled tube sample is then taken.

Where undisturbed samples are not required, split-barrel samples are obtained in accordance with ASTM D 1586, "Standard Test Method for Penetration Test and Split-Barrel Sampling of Soils." The SPT is accomplished by placing a hollow, thick-walled-tube sampler at the bottom of the boring

TABLE 6.18 COMMON SAMPLING METHODS

Sampler	Sample Type	Appropriate Soil Types	Method of Penetration
Split-barrel (Split-spoon)	Disturbed	Sands, silts, clays	Hammer driven
Thin-walled Shelby tube	Undisturbed	Clays, silts, fine-grained soils, clayey sands	Mechanically pushed
Continuous push	Partially Undisturbed	Sands, silts, and clays	Hydraulic push with plastic lining
Piston	Undisturbed	Silts and clays	Hydraulic push
Pitcher	Undisturbed	Stiff to hard clay, silt, sand, partially weathered rock, and frozen or resin impregnated granular soil	Rotation and hydraulic pressure
Dennison	Undisturbed	Stiff to hard clay, silt, sand and partially weathered rock	Rotation and hydraulic pressure
Continuous auger	Disturbed	Cohesive soils	Drilling with hollow-stem augers
Bulk	Disturbed	Gravels, sands, silts, clays	Hand tools, bucket augering
Block	Undisturbed	Cohesive soils and frozen or resin-impregnated granular soil	Hand tools

(ADAPTED FROM MAYNE ET AL., 2002)

and driving it 18 inches into the underlying soil by blows from a 140-pound hammer dropping 30 inches. The number of blows required to drive the sampler each 6-inch interval is recorded. The first 6-inch interval is regarded as a seating value, and the blows for the second and third increments are summed to give the SPT N-value or blow count resistance of the soil. If the sampler cannot be driven 18 inches, the number of blows for each 6-inch increment and for each partial increment is recorded on the boring log. For partial increments, the depth of penetration is recorded in addition to the number of blows. The SPT can be performed in a wide variety of soil types, as well as weak rocks, but it is not particularly useful for the characterization of gravel deposits or soft clays. The SPT provides a semi-quantitative measure of the stiffness or density of the soil in place. When the sampler is removed from the boring, a representative soil sample is recovered for classification and for laboratory tests that are applicable to disturbed soil samples, including moisture content, grain size analysis and Atterberg limits. The advantages and limitations of the SPT are summarized in [Table 6.19](#).

A properly conducted boring program entails close supervision by an experienced engineer or geologist. This supervision includes: (1) careful and detailed classification of the materials recovered from the boring, (2) preparation of a detailed log for each boring, noting the classification of the material and its condition, and (3) other significant observations such as water levels in the boring.

The boring log is the basic record for geotechnical exploration and provides a detailed record of the work performed and the subsurface conditions at the boring location and can be recorded on paper or on electronic data loggers. If recorded on paper, field boring logs should be written or printed legibly and should be as clean as is practical considering site conditions and weather. All appropriate portions of the boring logs should be completed in the field as the work is being performed.

A wide variety of drilling log forms are in use, but the specific form(s) to be used for a given type of boring will depend upon local practice. A boring log should provide a description of exploration procedures and subsurface conditions encountered during drilling, sampling and coring. The following information should be provided on a boring log:

- Survey data including boring location in reference to site coordinates, surface elevation, and bench mark location and datum, if available.
- An accurate record of any change in the planned boring locations.
- Identification of the soil and bedrock encountered, including density, consistency, color, moisture, structure, and geologic origin.
- The depths of the various generalized soil and rock strata encountered.
- Sampler type, depth, penetration, and recovery.
- Sampling resistance in terms of hydraulic pressure or blows per depth of sampler penetration; size and type of hammer; height of drop.
- Soil sampling interval and recovery.
- Rock core run numbers, including depths and lengths, core recovery, and rock quality designation (RQD).
- Drilling method used to advance and stabilize the hole.
- Comparative resistance to drilling.
- Observed loss of drilling fluid.
- Water level observations.
- The date and time that the boring was started, completed, and when water level measurements were made.
- Closure of borings.

TABLE 6.19 ADVANTAGES AND LIMITATIONS OF THE STANDARD PENETRATION TEST

Advantages	Limitations
Obtain both a sample and a number	Disturbed sample (index tests only)
Simple, rugged and suitable in many soils	Analysis required if varying numerical results are obtained
Can be used in weak rock	Not applicable for soft clays and silts
Available throughout the U.S.	High variability and uncertainty

(ADAPTED FROM MAYNE ET AL., 2002)

6.4.3.5 Undisturbed Soil Sampling

Undisturbed samples are usually obtained when the structure of the soil (e.g., strength and compressibility) is important to its behavior. Relatively undisturbed samples are commonly obtained by pushing a thin-walled tube into the soil at the bottom of the boring and removing the soil sample from the boring in the protective tube. The sampler typically has an approximate outside diameter of 3 inches and inside diameter of 2 7/8 inches. Thin-walled samplers vary in outside diameter between 2 and 3 inches and typically come in lengths from 28 to 36 inches. Larger diameter tubes are used where higher quality samples are desired and sampling disturbance must be kept to a minimum. The procedure for thin-walled tube sampling is described in ASTM D 1587, "Standard Practice for Thin-Walled Tube Sampling of Soils for Geotechnical Purposes."

Undisturbed sampling is generally practical only for fine-grained, cohesive soils that contain few rock particles. Undisturbed tube sampling of coarse gravels and coarse refuse with large particles is not practical because of the resistance to pushing the tube and potential damage to the tube. Special types of tubes and procedures are sometimes employed to obtain suitable undisturbed samples of very soft or sensitive soils, such as very wet fine refuse. These are described in Mayne et al. (2002). If these types of samples are desired, the ability of the potential drillers to obtain them should be verified.

The thin-walled tubes used for undisturbed sampling are manufactured using carbon steel, galvanized carbon steel, stainless steel, and brass. Carbon steel tubes are often used, but are unsuitable if the samples are to be stored in the tubes for more than a few days because of rusting. In stiff soils, galvanized carbon steel tubes are preferred because carbon steel is stronger, less expensive, and the galvanizing provides additional resistance to corrosion. Thin-walled tubes are manufactured with a beveled front edge to reduce pushing resistance and sample disturbance. Thin-walled tubes can be pushed with a fixed head or piston head. ASTM D 4220, "Standard Practices for Preserving and Transporting Soil Samples," provides guidance for field preparation, transport and storage of undisturbed samples prior to laboratory testing.

6.4.3.6 Rock Coring

Where borings must extend into weathered and unweathered rock, rock drilling and sampling are required. For disposal sites, defining the top of rock by drilling can be difficult, especially when large boulders are present and where the top of rock profile is irregular. In all cases, care must be taken in determining the top of rock because improper identification may lead to a miscalculated thickness of rock overburden above a mine or inaccurate determination of material quantities.

Destructive rock drilling is a relatively quick and inexpensive means for advancing a boring when an intact rock sample is not required. Destructive drilling can be used to determine the elevation of the top of rock or the elevation of the top of a mine void. Types of destructive drilling include air-track drilling, down-the-hole percussive drilling, rotary tricone (roller bit) drilling, rotary drag bit drilling and, in very soft rocks, augering with carbide-tipped bits. When destructive drilling is

employed, caution should be exercised in determining the top of soft rock because drilling proceeds rapidly, and weathered and soft rock can be easily penetrated, resulting in an inaccurate top-of-rock elevation.

When formations are encountered that are too hard to be sampled by soil sampling methods (typically more than 50 blows per inch with a 2-inch-diameter, split-barrel sampler), core drilling procedures should be employed, as described in ASTM D 2113, "Standard Practice for Rock Core Drilling and Sampling of Rock for Site Investigation." Seismic refraction or other geophysical methods can be used to assist in determining the top-of-rock elevation. Seismic-refraction data can also provide information between borings. The depth of rock coring will vary depending on site conditions, but as a minimum coring should extend to a depth sufficient to account for the presence of pervious or soft strata that could affect the stability of the embankment.

Core barrels may be single-, double-, or triple-tube types. A double-tube core barrel is commonly used because the inner and outer core tubes better isolate the rock core from the drilling fluid stream and the inner tube isolates the core from the rotating outer tube. In triple-tube core barrels, the inner tube may be longitudinally split to allow observation and removal of the core with reduced disturbance.

Rock coring can be accomplished with either conventional or wireline equipment. With conventional drilling equipment, the entire string of rods and core barrel are raised to the surface after each core run for rock core retrieval. Wireline drilling equipment allows the inner tube to be uncoupled from the outer tube and raised rapidly to the surface by means of a wire-line hoist. The main advantage of wireline drilling is the increased drilling production resulting from the rapid removal of the core from the hole. Wireline coring also provides improved quality of recovered core, particularly in soft rock, because this method minimizes rough handling of the core barrel during retrieval of the barrel from the borehole and when the core barrel is opened. Wireline drilling can be used on any rock coring project, but typically is used where boreholes are more than about 75 feet deep and rapid removal of the core from the hole has a greater effect on cost.

Although NX (2.154-inch-diameter) core is the size most frequently used for engineering explorations, both larger and smaller sizes are sometimes used. Larger core sizes will usually produce greater recovery and less fracturing during drilling.

The length of each core run should be limited to a maximum of 10 feet. Core run lengths should be reduced to 5 feet or less just below the rock surface and in highly fractured or weathered rock zones. Shorter core runs generally reduce the degree of damage to the core and improve core recovery in poor quality rock.

The core bit provides the grinding action at the bottom of the core barrel assembly that cuts the core from the rock mass. Diamond, carbide-tipped and sawtooth core bits are the most commonly used. Core bits are generally selected by the driller and are often approved by the geotechnical engineer. Bit selection should be based on drill bit performance for the expected formations and the proposed drilling fluid.

Clear water is most often used as the drilling fluid in rock coring because it is readily available, does not react with most rock types and does not require special disposal procedures. If collapsing holes or zones where there is loss of drill water are encountered, a drilling mud may be required for stabilizing the borehole. Drilling mud should be used with care because it will clog open joints and fractures and can adversely affect hydraulic conductivity measurements and piezometer installations. A settling basin should be used to remove drill cuttings and to allow recirculation of the drilling fluid. Unless contaminated with oil or other substances, drilling fluids can be discharged onto the ground surface.

Rock core should be carefully removed from the core barrel, placed in a rock core box appropriately sized for the diameter of core drilled, and visually classified. The rock core recovery and RQD should be calculated and recorded. ASTM D 6032, "Standard Test Method for Determining Rock Quality Designation (RQD) of Rock Core," should be followed in determining the RQD, which is a normalized measure of the degree of rock fracturing. The rock core should be preserved and transported following the guidance in ASTM D 5079, "Standard Practices for Preserving and Transporting Rock Core Samples." Additional guidance for visual classification, core handling and labeling, and other field practices is provided in Mayne et al. (2002). The application of RQD in geotechnical design is presented in Section 6.6.

6.4.3.7 Cone Penetrometer Test (CPT) and Piezocone Penetrometer Test (CPTu or PCPT)

An alternative or supplement to the SPT is the Cone Penetrometer Test (CPT), also referred to as Cone Penetration Test, an in-situ test that is fast, economical, and provides continuous profiling of soil strata and soil properties. The test is described in ASTM D 5778, "Standard Test Method for Performing Electronic Friction Cone and Piezocone Penetration Testing of Soils," and consists of pushing a cylindrical steel probe into the ground at a constant rate of 2 centimeters per second and measuring the resistance to penetration. The standard cone penetrometer has a conical tip with an apex angle of 60 degrees, a 10-cm² projected area for the cone, and a 150-cm² surface area for the friction sleeve. The ASTM standard also permits a larger diameter unit that has a 15-cm² tip and 200-cm² sleeve. The measured point or tip resistance is q_c and the measured side or sleeve resistance is f_s . An illustration of a typical cone penetrometer is provided in [Figure 6.12](#).

The CPT can be used in very soft clays to dense sands, but it does not work well in gravels or rocky terrain. The advantages and limitations of using the device are summarized in [Table 6.20](#). Because the CPT provides more accurate and reliable parameters for analysis, it is an excellent complement to traditional soil borings with SPT measurements. The CPT is not practical for coarse refuse where larger rock fragments can impede the penetrometer, but the method has been used to characterize the consistency and to estimate the engineering properties of settled fine refuse in impoundments.

A piezocone penetrometer test (CPTu or PCPT) is performed by advancing a cone penetrometer with transducers for measuring pore-water pressures. In clean sands, the measured pore pressures are nearly hydrostatic because the high hydraulic conductivity of the sand permits immediate dissipation of excess pore-water pressures mobilized by advancement of the cone. In clays, the advancement of the cone may result in the development of elevated pore-water pressures. If the advancement of the penetrometer is halted, the decay of pore-water pressures can be monitored with time and used to calculate an in-situ rate of consolidation and soil hydraulic conductivity. Details related to test methods, cone types and calibration, data reduction, and cone maintenance are provided in ASTM D 5778 and Lunne et al. (1997).

Piezocone penetrometer testing can be a viable technique for determination of gradational variability, strength, hydraulic conductivity and consolidation properties of fine coal refuse at existing refuse disposal sites. However, the measured cone resistance q_c must be corrected for pore-water pressures acting on unequal areas of the cone tip. This correction is most important for soft to stiff clays and silts and for very deep soundings where the hydrostatic pressures are high. Usually in sands, the correction is minimal because q_c is much greater than any mobilized pore pressures.

Because soil samples are not obtained with the CPT, indirect assessment of soil behavior is typically inferred from an examination of the test data. The data can be processed for use in empirical chart classification systems, or the raw readings can be interpreted by eye to determine soil strata changes. For example, clean sands are generally indicated by a total tip resistance q_T greater than 50 tsf, while for soft to stiff clays and silts, q_T is less than 20 tsf. The total tip resistance q_T is a function of the pore

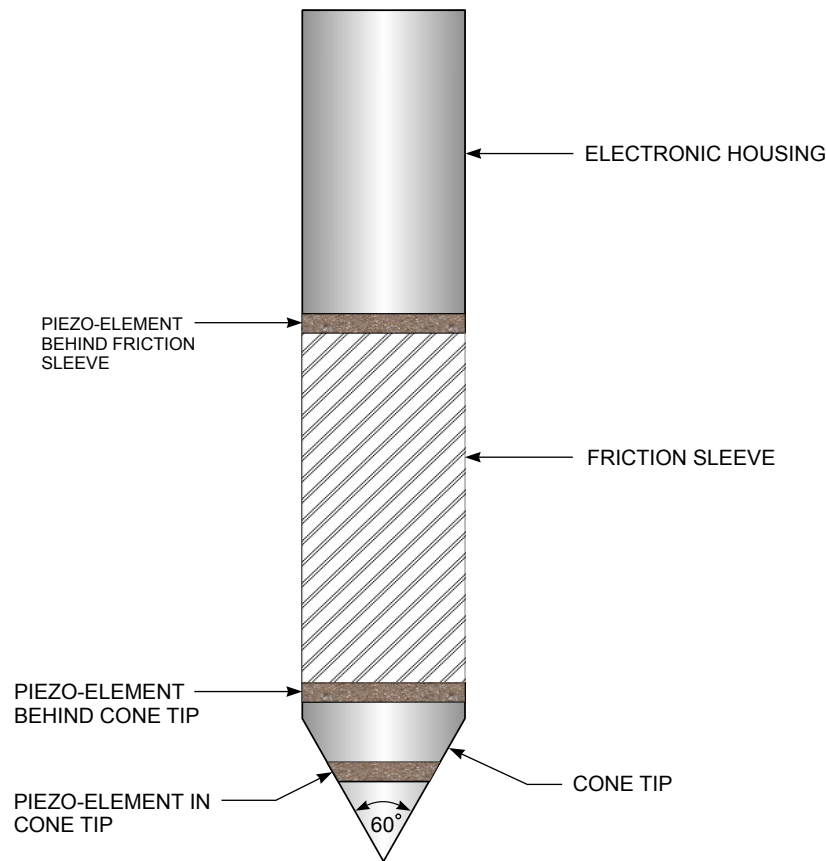

(ADAPTED FROM FHWA, 1992)

FIGURE 6.12 PIEZOCONE PENETROMETER

pressure behind the cone tip q_c and some factors related to cone geometry. This value is automatically calculated and plotted during the test.

Generally, pore-water pressures associated with penetration in loose sands are approximately equal to hydrostatic pressures, in contrast to penetration in dense sands where the pore-water pressure is typically less than hydrostatic. In soft to stiff intact clays, pore-water pressures associated with advancement of the penetrometer are generally several times the hydrostatic pressure. Notably, negative pore-water pressures are observed in fissured overconsolidated materials. The sleeve friction,

TABLE 6.20 ADVANTAGES AND LIMITATIONS OF THE CONE PENETROMETER TEST

Advantages	Limitations
Fast and continuous profiling	No soil samples are obtained
Economical and productive	Unsuitable for gravel or boulder deposits ⁽¹⁾
Results not operator-dependent	Requires skilled operator to run
Strong theoretical basis for interpretation	Electronic drift, noise, and calibration
Particularly suitable for soft soils	High capital investment

Note: 1. Except where special rigs are provided and/or additional drilling support is available.

(MAYNE ET AL., 2002)

often expressed in terms of a friction ratio ($FR = f_s/q_T$), is also a general indicator of soil type. In sands, FR usually falls in the range of 0.5 to 1.5 percent; in clays FR normally falls between 3 and 10 percent. A notable exception is that in sensitive and quick clays, a low FR is observed. An approximate estimate of clay sensitivity is $10/FR$ (Robertson and Campanella, 1983).

6.4.3.8 Field Vane Shear Test (FVST)

The field vane shear test (FVST) is used to evaluate the in-situ undrained shear strength of soft to stiff clays and silts, mine tailings and organic muck. The test is conducted in accordance with ASTM D 2573, "Standard Test Method for Field Vane Shear Test in Cohesive Soil," by inserting a four-bladed vane (Figure 6.13) into cohesive soil at the bottom of a boring and rotating the device about a vertical axis. The torque required to turn the device is measured. A variety of vane sizes, shapes, and configurations are available depending upon the consistency and strength characteristics of the soil. Vanes can have a blade diameter D ranging from 1.5 to 4.0 inches, a vane height H ranging between 1.0 and 2.5 D , and a blade thickness ranging from 0.006 to 0.125 inches. The end of the vane is usually rectangular or tapered at 45 degrees.

ASTM D 2573 provides relationships for converting the measured peak torque to a value of peak undrained vane shear strength S_{uv} based on the geometry of the vane. For a rectangular vane with $H/D = 2$:

$$S_{uv} = 6 T_{max} / (7\pi D^3) \quad (6-1)$$

where:

$$T_{max} = \begin{array}{l} \text{maximum measured torque corrected for apparatus and rod friction} \\ \text{(length times force)} \end{array}$$

Relationships for other vane geometries are presented in ASTM D 2573.

After the test to determine S_{uv} is completed, the undrained steady-state (residual) shear strength S_{ur} can be determined by quickly rotating the vane another 5 full revolutions to fully remold the soil and then repeating the shear test. The ratio of peak to remolded undrained strengths is the sensitivity S_t . Table 6.21 provides a summary of the advantages and limitations of the FVST. Additional guidelines related to application of the FVST are presented in Mayne et al. (2002).

ASTM D 2573 recommends a loading rate of no faster than 0.1 degree per second (15 minutes for 90 degrees of rotation). At this rotation rate, the time required to reach undrained peak strength typically ranges from 2 to 5 minutes, but in very soft clays the time to failure may be as much as 10 to 15 minutes.

Chandler (1988) and Morris and Williams (2000) investigated the applied loading rate. Chandler applies a theoretical method by Blight (1968), and indicates that for typical vanes and a time to failure of 1 minute, the test will be undrained if the coefficient of consolidation (c_v) is less than 0.035 cm²/sec (3.3 ft²/day). Blight defined time to failure as the time from the beginning of vane rotation. Morris and Williams (2000) proposed a revision to Blight's theoretical method, which accounts for the pore pressure increase due to vane insertion as well as vane rotation and defines time to failure as the time from vane insertion. Morris and Williams indicate that, for a vane diameter of 63 mm (2.5 in), a time to failure of 2 minutes will result in an undrained test for materials with c_v as high as 1450 m²/year (42 ft²/day). This value of c_v should encompass coal refuse and natural materials with a plasticity index (plastic limit minus liquid limit) of 10 or higher.

To minimize drainage in fine coal refuse during the FVST, the rotational loading should be applied as soon as possible after vane insertion, and the loading rate should be increased significantly from the

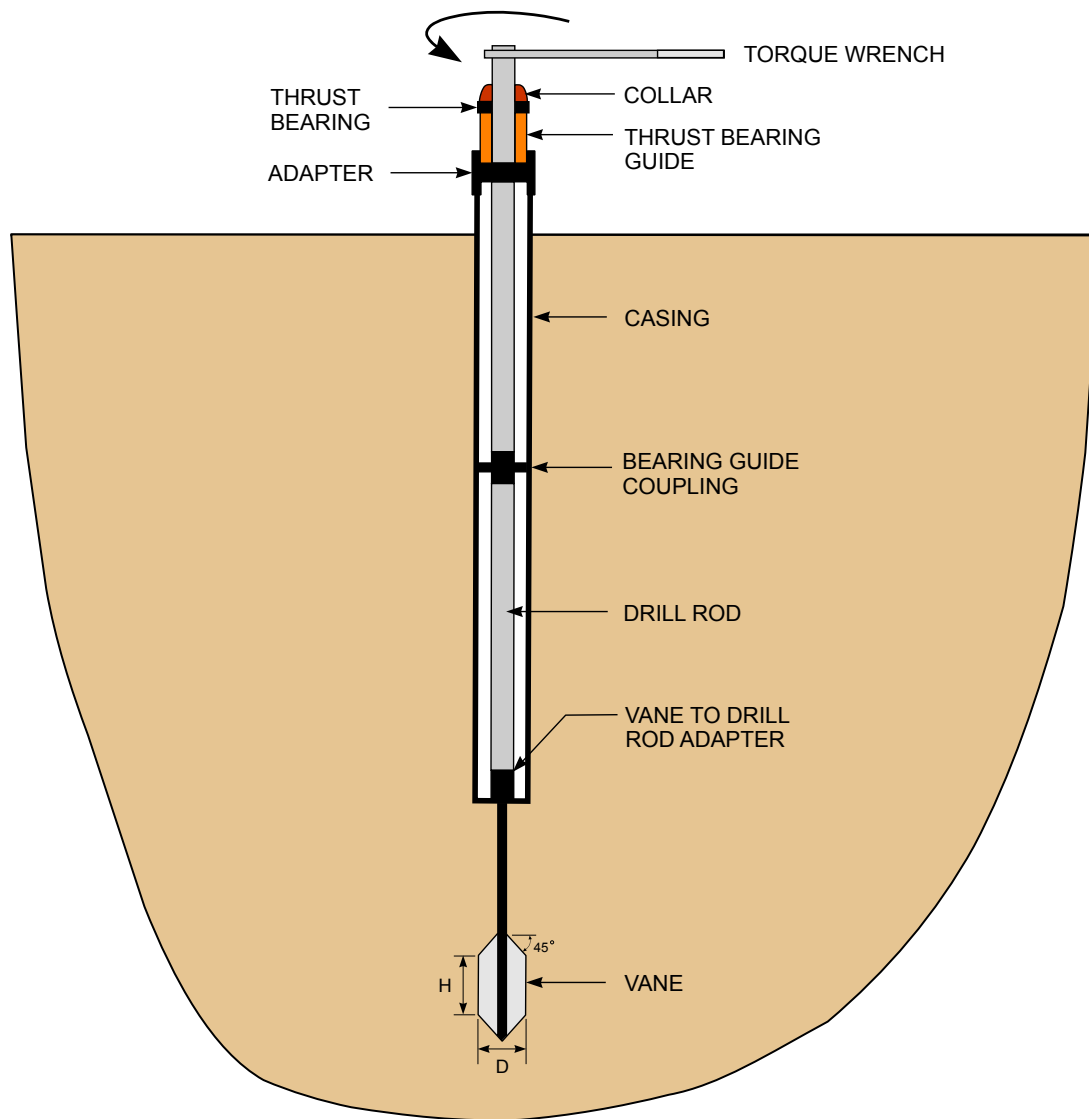

FIGURE 6.13 FIELD VANE SHEAR TEST SETUP

ASTM D 2573 recommendation in order to achieve failure within about 1 minute. For a soft material, if only the peak strength is being measured, a loading rate of 2 to 10 degrees per second is reasonable, but if the undrained, steady-state (residual) strength is being measured as well as the undrained peak strength, then the following procedure is recommended:

1. Initially apply the torque at a rate of about 10 degrees per second.
2. After the peak strength has been reached, increase the rate of rotation to at least 60 degrees per second (6 seconds per revolution or faster) for at least 5 complete revolutions to remold the material.
3. Avoiding a rest period, slow the rate of rotation to about 10 degrees per second to measure the steady-state strength.

The rotation and torque should be measured and recorded as the test is conducted, which can be accomplished with a gear box and stylus recording system or other type of data acquisition system. The rod and apparatus friction corrections (per ASTM D 2573) should be performed for the rates of rotation actually used in steps 1 and 3.

TABLE 6.21 ADVANTAGES AND LIMITATIONS OF THE FIELD VANE SHEAR TEST

Advantages	Limitations
Assessment of undrained strength (S_{uv})	Limited application to soft to stiff clays
Simple test and equipment	Slow and time-consuming
Measurement of in-situ clay sensitivity (S_t)	Raw S_{uv} needs correction (empirical)
Long history of use in practice	Can be affected by sand lenses and seams

(MAYNE ET AL., 2002)

Studies by several researchers have demonstrated the importance of correcting the measured vane strength for use in stability analyses involving embankments on soft ground, bearing capacity analyses, and for analyses associated with excavations in soft clays. The correction to obtain the mobilized shear strength is given by:

$$S_{u (mobilized)} = \mu_R S_{uv} \quad (6-2)$$

where:

$$\mu_R = \begin{array}{l} \text{empirical correction factor related to plasticity index (PI) based on} \\ \text{back calculation from failure case history records of full-scale projects} \\ \text{(dimensionless)} \end{array}$$

Bjerrum (1972) recommended values of μ_R to correct the measured peak field vane strength (with a time to failure of a few minutes or less) to a value of $S_{u (mobilized)}$ (during a full-scale slope failure corresponding to a time to failure of several weeks to several months) that may be appropriate for stability failures.

Chandler (1988) combined Bjerrum's case history data and other data sets to develop a more specific strain-rate correction factor:

$$\mu_R = 1.05 - b (PI)^{0.5} \quad (6-3)$$

where b is a dimensionless rate factor that depends on the time to failure (t_f) in minutes (for a full-scale slope stability failure):

$$b = 0.015 + 0.0075 \log t_f \quad (10 \text{ min} < b < 10,000 \text{ min}) \quad (6-4)$$

Values of μ_R as a function of PI and t_f are presented in [Figure 6.14](#). Slope stability failures should generally be considered to have t_f values of 10,000 minutes (7 days) because of the construction methods involved.

These strain rate correction factors are for peak undrained strengths and are based on case histories for natural clays, not fine coal refuse. However, until more research is available, the same correction factors should be applied to fine coal refuse and to remolded undrained (steady-state) strength as well as to undrained peak strength.

The FVST is applicable only to soft to medium stiff clay-like materials that are relatively impermeable such that they remain undrained during the test. If drainage occurs, the measured torque and resulting calculated strength will exceed the actual value. No published guidance is available on limitation

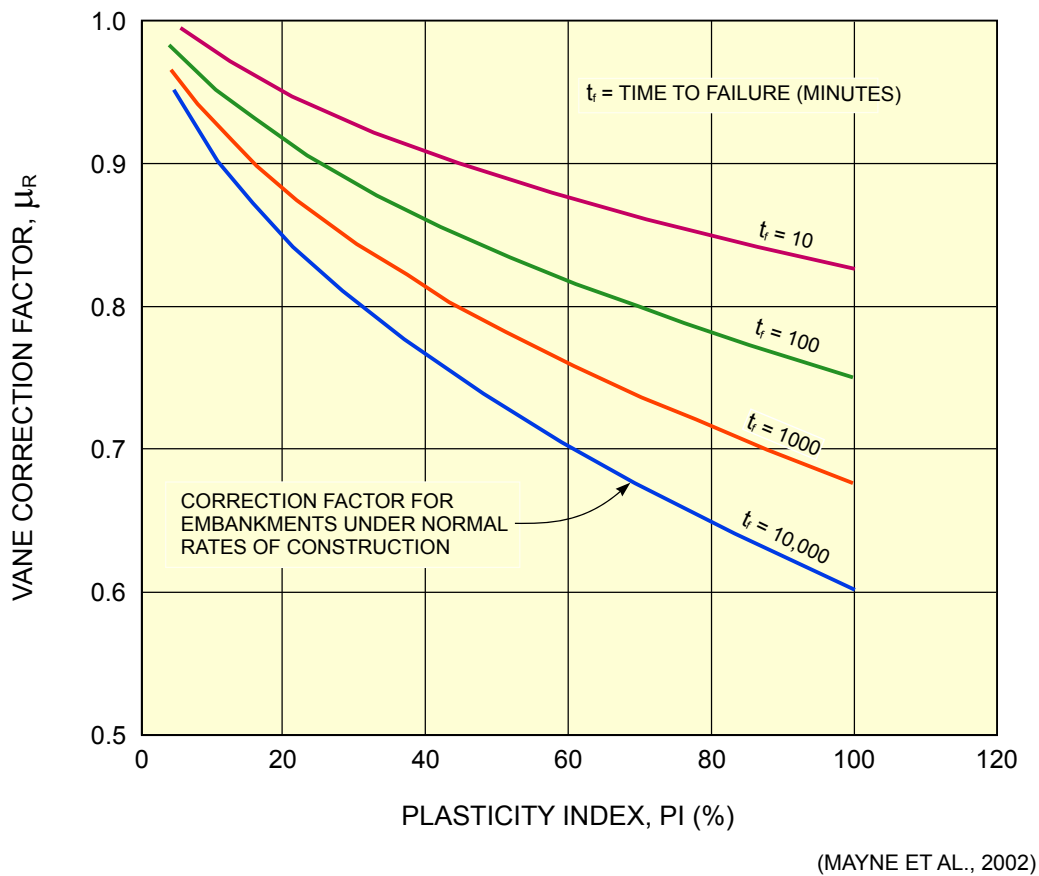

FIGURE 6.14 VANE CORRECTION FACTOR

relative to PI; this Manual recommends that the FVST should not be used for materials with a PI of 7 or less because these materials are likely to drain during the test. FVST should be used with caution in materials with higher PI that contain thin layers of sand-like material because the sand-like layers may allow drainage. For material with PI between 7 and 10, FVST should only be used if supporting data are provided to demonstrate that the test was undrained. Material samples should be recovered from each test zone for geotechnical index testing (moisture content, grain size distribution, and Atterberg Limits at a minimum). Also, CPT and piezocone measurements performed adjacent to an FVST can be used to measure the rate of pore-pressure dissipation, so that it can be confirmed that the zone in which the FVST is run is relatively impermeable. The piezocone data may be used to estimate the value of c_v in order to confirm that the rotation rate is sufficiently rapid that the test can be considered undrained.

The FVST is not intended for stiff clay-like materials because these materials will normally exceed the torque capacity of the FVST device. The FVST cannot be used for testing sand-like material or coarse refuse because (1) these materials will drain during the test and (2) the shear strength of these materials will exceed the capacity of the FVST device.

6.4.3.9 Directional (Longhole) Drilling

Directional or longhole drilling refers to: (1) in-mine drilling operations used to identify geological and mining conditions in advance of mining and (2) surface drilling through an outcrop to determine cover and coal barrier thickness. Development in the 1990s of systems with instrumentation to measure drill bit location, high-thrust drilling equipment, powerful downhole motors and high-strength drill tubing has allowed the implementation of this technique. In combination with hydraulic frac-

turing techniques used to increase connectivity between boreholes, directional drilling has been employed to reduce in-situ methane gas contents in low-hydraulic-conductivity coal and to fracture a massive sandstone roof in advance of longwall mining (Brunner and Schwoebel, 1999). Depending on conditions, drilling rates of 300 feet per shift and drilling accuracies of approximately 1 degree in azimuth and 0.5 inches in pitch can be achieved. The longest reported in-mine horizontal borehole exceeds 5,000 feet in length (Brunner and Schwoebel, 1999). Directional drilling has also been used to locate old abandoned workings, drain accumulations of mine water, and degasify gob areas (Kravits and Schwoebel, 1994). While conventional coring should not be attempted in a long, directionally-drilled borehole, spot cores can be taken at selected locations (Kravits and Schwoebel, 1994). As such, the technique may have applicability for accurately locating and determining the thickness of horizontal in-mine barriers and can be a means of validating geophysical methods for locating and sizing barriers in mines.

6.4.3.10 Field Hydraulic Conductivity Tests

The hydraulic conductivity of soil or rock is often measured in place during subsurface exploration to determine if seepage through foundation materials will be an important design consideration. The hydraulic conductivity of soils near the ground surface can be measured in hand-dug pits or cased holes. At greater depths the hydraulic conductivity can be determined in the borings used for sampling, provided that the borehole is cased and the hydraulic conductivity test will not affect sampling of an important soil layer immediately below the test level. [Table 6.22](#) summarizes various methods for measurement of hydraulic conductivity in the field. Additional guidance in selecting field test methods is provided in ASTM D 4043, "Standard Guide for Selection of Aquifer-Test Method in Determining of Hydraulic Properties by Well Techniques."

The most commonly performed field hydraulic conductivity test involves a sudden change (increase or decrease) of water level in a borehole and measurement of the response in terms of water level versus time. The test procedure and methods of analysis are presented in ASTM D 4044, "Standard Test Method (Field Procedure) for Instantaneous Change in Head (Slug) Tests for Determining Hydraulic Properties of Aquifers." Hydraulic conductivity values determined by this procedure often fail to correspond well with values predicted from laboratory testing due to: (1) characteristic differences (e.g., gradation and density) between the soils tested in the field and in the laboratory, (2) clogging of the boring face by soil particles suspended in the water, (3) varying directional hydraulic conductivity of layered soil that cannot be duplicated in the laboratory with disturbed soil samples, or (4) failure to conduct the field test in saturated soils, resulting in measurement of the rate of saturation rather than hydraulic conductivity. Because field hydraulic conductivity tests inherently account for the effects of geologic variations, they are generally more representative of in-situ conditions than laboratory tests. However, the evaluation and interpretation of the test data require knowledge of the test conditions and of the possible effects of these test conditions on the results.

The field hydraulic conductivity test for rock is similar to that for soil, as described in ASTM D 4630, "Standard Test Method for Determining Transmissivity and Storage Coefficient of Low-Permeability Rocks by In Situ Measurements Using the Constant Head Injection Test." The test is performed in a rock boring using water pumped under pressure from the ground surface. Two types of tests can be performed: a single-packer test or a double-packer test.

In the single-packer test, a pipe is inserted into a boring with a packer at the lower end of the pipe. The packer is expanded mechanically or pneumatically from the ground surface to seal the annulus between the walls of the boring and the pipe, and water is pumped down the pipe into the boring below the packer. Since the depth and diameter of the hole below the packer, the applied water pressure, and the rate of flow of water through the system are known, the average hydraulic conductivity of the rock below the packer can be calculated.

TABLE 6.22 FIELD METHODS FOR MEASUREMENT OF HYDRAULIC CONDUCTIVITY

Test Method	Applicable Soils	Reference
Various field methods	Soil and rock aquifers	ASTM D 4044
Pumping tests	Drawdown in soils	ASTM D 4044
Slug tests	Soils at depth	ASTM D 4044
Constant head injection	Low-hydraulic-conductivity rocks	ASTM D 4630
Pressure pulse technique	Low-hydraulic-conductivity rocks	ASTM D 4630

(ADAPTED FROM MAYNE ET AL., 2002)

In the double-packer test, a selected zone within the boring is tested by placing one packer at the bottom and another packer at the top of the test zone. Water is then pumped through the pipe into the annular space between the packers. The hydraulic conductivity is computed by the same procedure as for the single-packer test.

During hydraulic pressure testing of rock, the water pressure applied to the test zone must not exceed the pressure caused by the weight of overburden above the test zone. Excess pressures may force water into joints, bedding planes or fractures and cause additional fracturing of the rock by lifting the overburden. This “jacking” of the rock can seriously increase the amount of leakage that will occur later and may also decrease the stability of the rock mass and its ability to resist the loads applied by an embankment or other surface loading.

Hydraulic pressure testing to measure rock hydraulic conductivity is an essential part of subsurface exploration where an impoundment is planned and where groundwater leakage could create unsafe uplift pressures or piping of the embankment or foundation soils. In addition to posing a threat to the safety of the embankment and natural slopes, excessive leakage can increase stream and groundwater pollution down gradient from the refuse disposal facility. The hydraulic conductivity values obtained from hydraulic pressure testing allow the prediction of quantities and locations of leakage from the impoundment. If rock zones where excessive leakage could occur are observed, grouting of the rock formations may be required. Houlsby (1990) and Weaver and Bruce (2007) discuss procedures and materials for grouting rock formations to reduce water flow.

6.4.3.11 Groundwater-Level Measurements

For new embankments, determination of the groundwater level in the planned construction area is important to construction requirements, particularly where excavations are planned. An understanding of the groundwater regime is essential in determining the direction and rate of possible seepage from an impoundment and may aid in estimating the overall hydraulic conductivity of the foundation materials.

Using piezometers to measure the phreatic surface level within an existing embankment is often the most important of the field tests used for evaluation of an existing coal refuse disposal facility, whether there is an impoundment or not. ASTM D 4750, “Standard Test Method for Determining Subsurface Liquid Levels in a Borehole or Monitoring Well (Observation Well),” describes procedures that should be followed in measuring groundwater levels. Piezometers or standpipes should generally be installed in exploration boreholes. Common techniques for installing piezometers and standpipes are presented in Chapter 13 along with monitoring procedures. The accuracy of data obtained from piezometers is directly related to the care taken in their installation. Therefore piezometer installation should always be under the supervision of a qualified engineer or geologist.

6.4.3.12 Water Flow and Quality Tests

In addition to phreatic surface level measurement with piezometers, valuable information for an existing impounding refuse disposal facility can be gained from: (1) monitoring flows from nearby springs or seep areas with weirs and (2) evaluating water quality aspects of these flows. As an example, measuring the volume of flow from a spring below an impoundment during both wet and dry periods, and as the impoundment level changes, will provide an indication of the rate of seepage from the impoundment and the effect on the overall groundwater system. Likewise, simple field measurements of temperature and acidity of seepage will allow comparison with similar measurements for the water in the impoundment and/or the inflow groundwater. Flow measurements and related water quality data are generally less important in the design of a new disposal facility, but the data are useful for future evaluation of the effect of the impoundment on the local and regional groundwater and surface water quality.

The type of weir to be used for flow monitoring and related construction requirements are determined by the magnitude of flow to be measured and the type of material in which the weir will be placed. In the case of very small seeps, the flow volume can be estimated simply by observation. If the flow initially passes over a “natural weir,” such as a rock outcrop or through an existing pipe, estimates can be made without installing special instrumentation. Construction of weirs and methods for accurately measuring flows from weirs and pipes are discussed in detail in Chapter 13.

Field testing of water can be performed using portable equipment to obtain indicator parameters such as pH, specific conductance and temperature, as well as some other mining-related parameters. Where measurements of additional constituents and characteristics of seepage water (including sulfate, chloride, iron, manganese, acidity, alkalinity, and dissolved and suspended solids) are desirable, additional water sampling and laboratory testing can be performed.

6.4.3.13 Backfilling of Boreholes

Boreholes at coal refuse disposal facility sites should not be left open, particularly if they are located beneath embankments or impoundments, or if they can potentially provide a pathway for fluid flow that is detrimental to site safety. Open boreholes can be backfilled with drill cuttings, cement grout, bentonite, and other materials depending on the objectives. Where there is no concern related to fluid migration or the impact of seepage on ground conditions, backfilling with cuttings or other materials may be acceptable. As a practical matter, boreholes in cohesionless soils may collapse when not supported, and it may not be possible (or necessary) to backfill such boreholes. Grouting of an open borehole is generally performed for the purpose of constructing a barrier that will prevent the vertical migration of fluids between geologic units. At active mine sites, the purpose may be to maintain the barrier between the mine workings and other strata. Materials employed for backfilling boreholes include cement, bentonite slurries, dry bentonite, and fast-setting cement grouts. Placement can be accomplished by tremie, pumping, and surface pouring. Site-specific considerations for a grouting program include: (1) whether to grout, (2) where to grout, and (3) the method of deployment.

ASTM D 5299, “Decommissioning of Ground Water Wells, Vadose Zone Monitoring Devices, Boreholes, and Other Devices for Environmental Activities,” presents guidance on methods and materials for closing of boreholes. While this standard is primarily oriented to environmental activities, it can be used to decommission boreholes where no contamination is observed. Attributes of common borehole plugging materials are discussed in the standard.

Grouting of boreholes that penetrate mines requires special provisions for supporting the borehole plug above the mine void (and potentially in the mine floor, if the boring is advanced through the mine). Frequently, sacrificial casing is left in the mine void to support the plug, although a grout basket has been used to allow sealing the borehole and to permit grouting.

6.4.4 Geophysical Methods

Applied geophysics is a rapidly evolving field, and the applicability of geophysical techniques to coal refuse disposal facilities will continue to advance with respect to the aspects of data gathering, processing, interpretation and presentation of the geophysical data. Two basic deployments of geophysics are available: (1) surface surveys and (2) measurements from boreholes. Airborne geophysical techniques are not discussed herein, as their application in terms of identifying features of interest with respect to coal refuse disposal facilities is still in the experimental stage. Nevertheless it is worth noting that in some cases airborne electromagnetic (EM) surveys have been used to map flooded, abandoned coal workings (Love et al., 2005), and aeromagnetic surveys have been used for many years to map abandoned well casings, which can be a significant hazard to coal mining (Frischknecht et al., 1985).

Numerous sources of information related to geophysics are available in the general literature. A good source of information is the Environmental and Engineering Geophysical Society (EEGS) in Denver, Colorado, which annually holds the Symposium on the Application of Geophysics to Engineering and Environmental Problems (SAGEEP). The SAGEEP proceedings are an excellent source of up-to-date information on the application of engineering geophysics to the types of problems that could be encountered at a coal refuse disposal facility. Other comprehensive compilations of geophysical techniques for subsurface exploration for engineering applications include Ward (1990), USACE (1995a), Sabatini et al. (2002), Wightman et al. (2003), and Sirles (2006). The Federal Highway Administration (FHWA) presents summaries of geophysical techniques at their web site. This material is substantially based on the USACE (1995a) work.

MSHA (2008) is a summary report of mine void detection demonstration projects that were performed to evaluate the use of geophysical techniques for detection of underground mine workings. These projects include actual field demonstrations of void detection at mine sites using seismic methods, electrical resistivity, electromagnetics, and radar.

The following ASTM standards provide guidance for conducting geophysical exploration:

- D 6429, "Standard Guide for Selecting Surface Geophysical Methods"
- D 6430, "Standard Guide for Using the Gravity Method for Subsurface Investigation"
- D 6431, "Standard Guide for Using the Direct Current Resistivity Method for Subsurface Investigation"
- D 6432, "Standard Guide for Using the Surface Ground Penetrating Radar Method for Subsurface Investigation"
- D 5753, "Standard Guide for Planning and Conducting Borehole Geophysical Logging"
- D 6639, "Standard Guide for Using the Frequency Domain Electromagnetic Method for Subsurface Investigations"
- D 7128, "Standard Guide for Using the Seismic-Reflection Method for Shallow Subsurface Investigation"
- D 6820, "Standard Guide for Use of the Time Domain Electromagnetic Method for Subsurface Investigation"

While ASTM guides provide useful background information on geophysical techniques, they may be dated in terms of defining procedures for data acquisition, processing, interpretation and presentation. For example, ASTM D 6431, "Standard Guide for Using the Direct Current Resistivity Method for Subsurface Investigation," discusses the technique in terms of acquisition with a four-electrode system and processing of one-dimensional data sets with computer programs developed in the 1970s. Modern resistivity surveys are commonly conducted with multi-electrode arrays, and the data are routinely processed and interpreted in terms of 2D profiles or 3D blocks.

6.4.4.1 Surficial Geophysical Techniques

In general terms, surface geophysical testing can be used to create a general image of subsurface conditions that can be checked by intrusive means such as borings or test pits. Data from geophysical testing should always be correlated with information from direct methods of exploration. Often, a combination of geophysical and direct exploration methods provides the best approach for interpreting subsurface conditions. When conducted at the outset of a subsurface investigation program, geophysical exploration can prove to be cost-effective through reduction of the number of borings needed for characterization of a site.

Conventional applications of surface geophysics include: (1) establishing the stratification of subsurface materials, (2) mapping the top of bedrock, depth to groundwater, and extent and quantity of soil deposits, and (3) determining the rippability of hard soil and rock. Over the past several years some improvements in traditional geophysical techniques have enhanced capabilities for the detection of abandoned mine workings and the presence of karst-related voids.

As summarized in [Table 6.23](#), surface geophysical testing offers some advantages and limitations that should be understood before a technique is selected for a specific application.

[Table 6.24](#) presents an overview of surficial geophysical methods and techniques in relation to the physical parameters measured and exploration objectives for coal refuse disposal facilities. The following text describes the most commonly used geophysical techniques listed in the table.

6.4.4.1.1 Seismic Refraction

The seismic refraction technique consists of measuring the first arrival of P- and/or S-waves at varying distances from a seismic source. The most common application of this technique is the determination of the depth to bedrock, which requires that the upper layer velocity (soil/weathered or soft rock) is less than that of the lower layer (competent rock). If a high-velocity surface layer is present, the technique is not effective. For this reason, the technique is generally not applicable for detection of mine voids.

TABLE 6.23 ADVANTAGES AND LIMITATIONS OF SURFACE GEOPHYSICAL TESTING

Advantages	Limitations
<ol style="list-style-type: none"> Many geophysical tests are non-invasive and thus offer significant benefits in cases where conventional drilling, testing, and sampling are difficult (e.g., deposits of gravel, talus deposits or access constraints). Geophysical testing generally covers a relatively large area, thus providing the opportunity to characterize large areas with relatively limited testing. It is particularly well suited to projects having large areal extent (e.g., new refuse disposal facility). Some types of geophysical measurement can assess the characteristics of soil and rock at very small strains (0.001%), thus providing information on truly elastic properties. Most geophysical methods are relatively inexpensive when considering cost relative to the relatively large areas over which data can be obtained. A properly performed geophysical survey can reduce the number of borings required for site characterization. 	<ol style="list-style-type: none"> Geophysical testing, when applied to locating changes in soil and/or rock properties, will be effective only if a target of interest has a physical contrast with the surrounding ground. Results are generally interpreted qualitatively. Useful results can only be obtained by an experienced engineer or geologist who is familiar with the particular testing method. Specialized equipment is required, as compared to more conventional subsurface exploration methods. Results from surface geophysical testing should be validated using direct methods of exploration such as borings.

(ADAPTED FROM SABATINI ET AL., 2002)

Seismic waves are usually created using a sledge hammer for depths up to about 50 feet and with explosives for depths up to about 100 feet. Other sources such as vibrators are sometimes used. Initially, the seismic waves travel solely through the soil to arrive at geophones (vibration transducers) located away from the source. The seismic waves also propagate through the overburden and refract along the bedrock surface. While the waves are traveling along this surface, they continually refract seismic waves back to the ground surface that are also detected by the geophones and recorded with a seismograph. The result is the generation of travel-time curves, as shown in Figure 6.15. The method can often be a low-cost (compared to boreholes) method of bedrock mapping and overburden estimation. When measurements are obtained with a high degree of redundancy, the result is a reliable acoustic image of the subsurface in terms of layers and variations of seismic velocity within the individual layers.

Seismic refraction data can also be useful for determining the rippability of rock materials using heavy construction equipment. Companies such as Caterpillar have prepared graphs comparing rippability versus P-wave velocity for various equipment types, an example of which is shown in Figure 6.16.

The design of a seismic refraction survey involves locating the profiles where data are desired and determining the length of the array of geophones (the geophone spread) and the geophone spacing.

TABLE 6.24 SURFACE GEOPHYSICAL METHODS IN RELATION TO TYPICAL INVESTIGATION OBJECTIVES

Geophysical Method	Dependent Physical Property	Applications (see key below)									
		1	2	3	4	5	6	7	8	9	10
Seismic refraction	Elastic moduli; density	P	P	P	S	X	X	X	M	M	S
Seismic reflection	Elastic moduli; density	S	M	S	S	X	P	X	X	P	P
Resistivity	Resistivity	P	X	X	P	S	P	X	P	M	S
Spontaneous potential (SP)	Potential differences	X	X	X	X	P	X	X	X	X	X
Electromagnetics (EM)	Conductivity; inductance	M	X	X	P	S	S	P	S	P	S
Ground penetrating radar	Permittivity; conductivity	M	X	X	X	M	S	M	X	S	S
Gravity	Density	X	X	X	X	X	P	X	X	X	X
Magnetics	Magnetic susceptibility	X	X	X	X	X	M	P	X	X	X

Key to Techniques and Applications

Technique Applicability	Applications
P – primary technique	1 – depth to bedrock
S – secondary technique	2 – rippability of rock and hard soil
M – may be used but probably not the best approach	3 – elastic properties of coal refuse, soil and rock
X – not applicable	4 – hydrogeological investigations
	5 – location of seepage pathways in a dam
	6 – location of mine workings or other subsurface voids
	7 – abandoned well detection
	8 – variations of coal refuse composition
	9 – location of faults/fractures/geologic structures
	10 – determination of soil/bedrock stratigraphy

(ADAPTED FROM SIRLES, 2006)

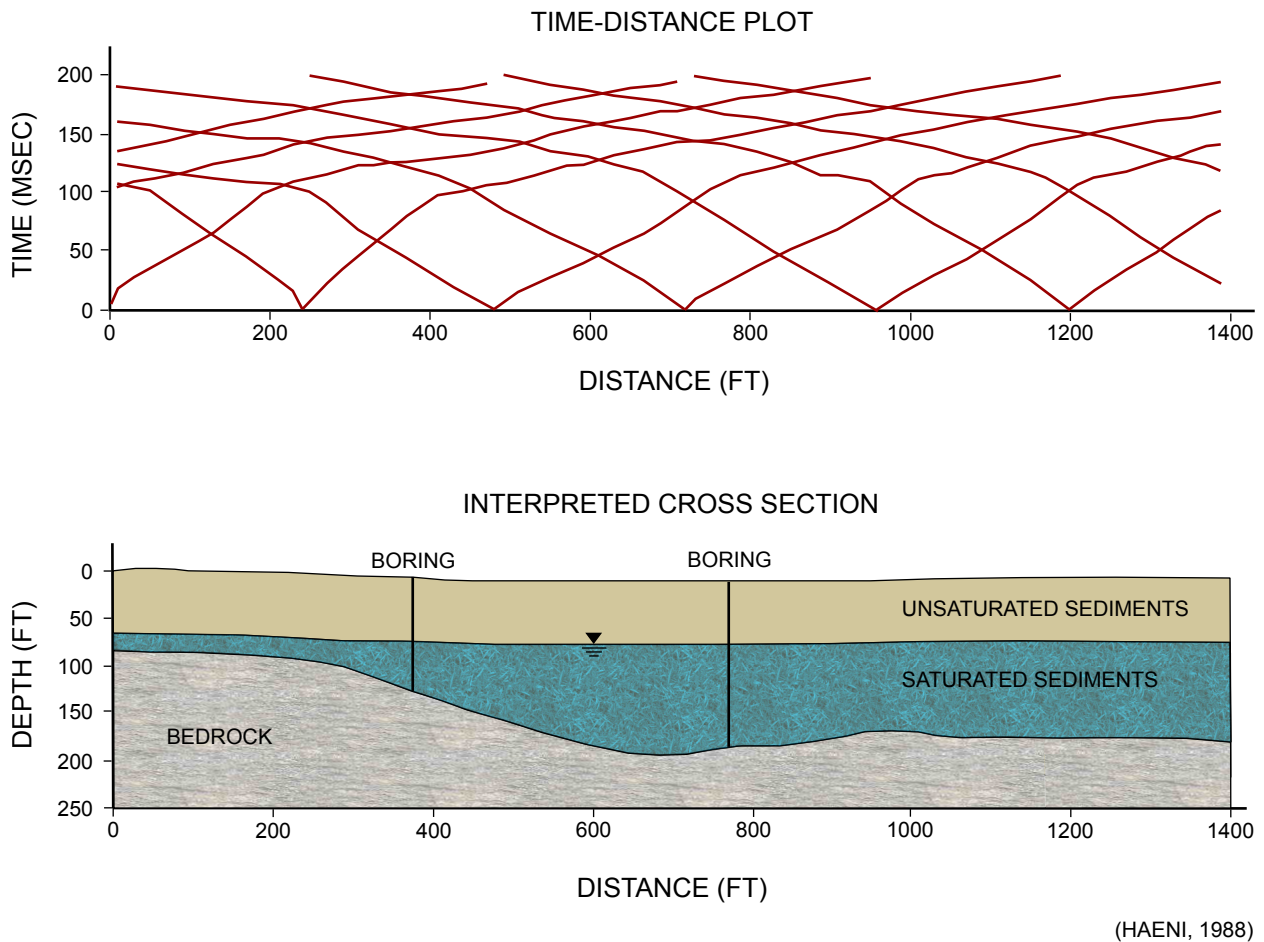
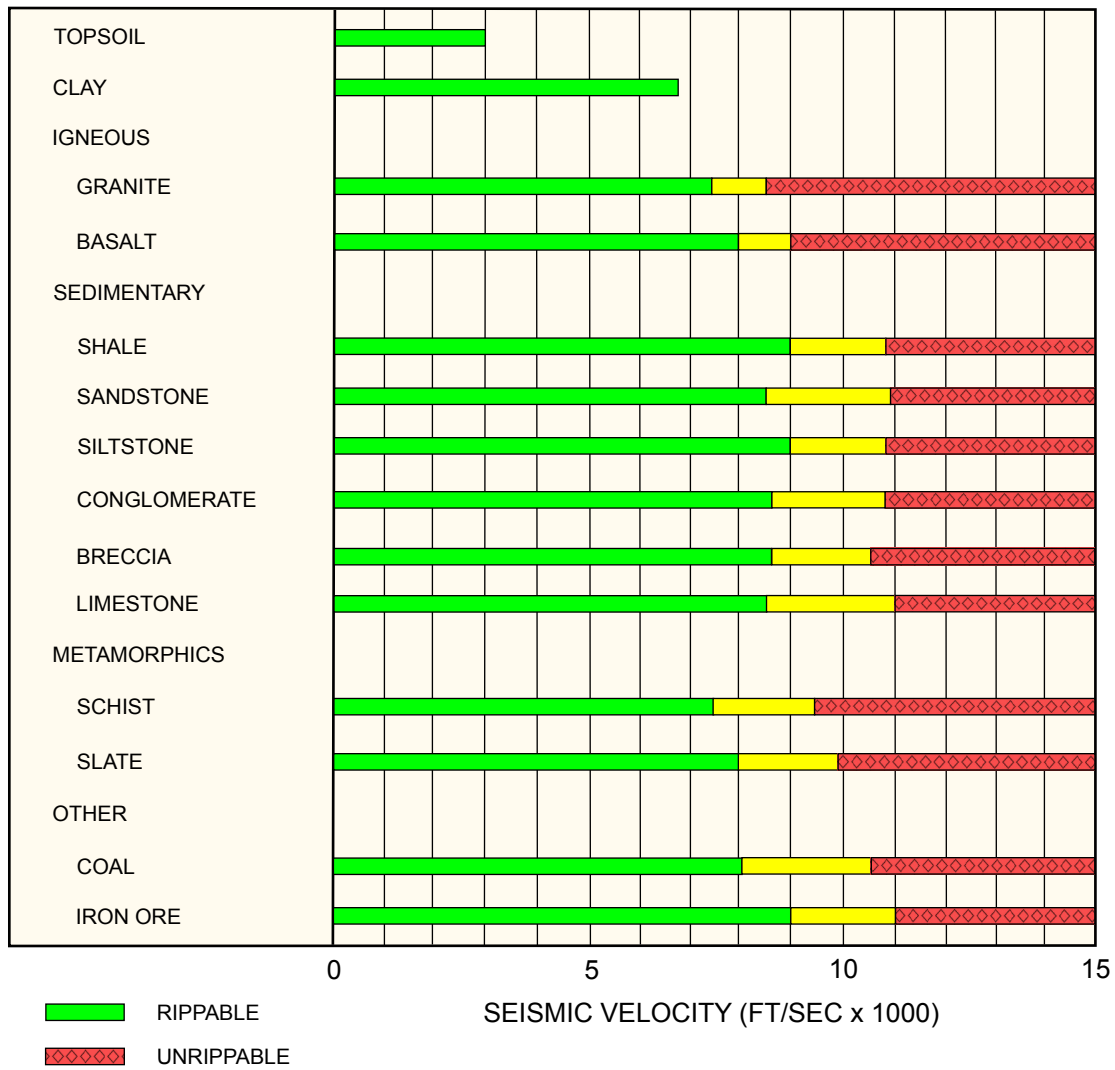

FIGURE 6.15 TYPICAL SEISMIC REFRACTION DATA WITH INTERPRETATION

The length of the spread depends on the required depth of penetration. As a rule of thumb, the length of the spread needs to be at least four times the depth of interest. Seismic “noise” originates from ambient vibrations that can be caused by sources such as traffic or wind. Obtaining multiple recordings from the same location and summing (stacking) the results or covering the geophones with sand bags can reduce the effect of this type of interference. Improved results with the seismic refraction technique can also be obtained when multiple refractions from the same refractive interface generated by multiple shots are received at a given geophone. This multiplicity of data is obtained by using a single geophone spread with multiple shot points. Commercial engineering seismographs designed for the seismic refraction technique usually allow for simultaneous recording from spreads with either 12 or 24 geophones, although some commercial equipment will allow for recording with 96 or more geophones.

There are several steps in the processing and interpretation of seismic refraction data. Firstly, it is necessary to pick the first arrival time for P-wave analysis and to tabulate this information. If the purpose is to obtain the S-wave velocity, then it is necessary to pick the onset of the S-wave arrival, which is more difficult than picking the P-wave arrival, because the S-waves lie within the wave train of the P-wave. Analytical procedures for processing the data commonly use either the generalized reciprocal method (GRM) or the delay-time method for the inversion and interpretation of refraction data. Both methods are suitable for resolving multilayer profiles with structural complexities (dips up to about 20 degrees). The acquisition of redundant data optimizes the accuracy of both interpretive techniques. The end result is a cross section of the ground with velocities assigned to each layer, as depicted in Figure 6.15.



(CATERPILLAR, 2008)

FIGURE 6.16 CORRELATION OF RIPPABILITY WITH P-WAVE VELOCITY FOR CATERPILLAR D9

When S-wave arrivals are picked from a seismic refraction record, it is possible to use the S-wave velocity to calculate the elastic properties of the identified layers. In practice, it can be difficult to identify S-waves, even when a horizontally-polarized source and horizontal geophones are used. Although there are numerous published examples (Johnson and Clark, 1992; Ellefsen et al., 2005) of the successful calculation of S-wave velocity from refraction data, in practice the most reliable methods for measuring elastic properties of the subsurface are from crosshole or downhole surveys, as discussed in Section 6.4.4.2.

6.4.4.1.2 Seismic Reflection

Application of the seismic reflection technique involves measuring the travel time required for a seismic wave generated at or near the surface (P-wave or S-wave, depending on the survey setup) to return to surface or near-surface geophones after reflection from acoustic interfaces between subsurface layers (Figure 6.17). Seismic reflection is the most powerful of all geophysical techniques for mapping subsurface layering and is by far the most commonly applied method for oil and gas exploration. It is also the most sophisticated of all geophysical methods and requires highly specialized equipment and processing software for its successful application. For this reason, the tech-

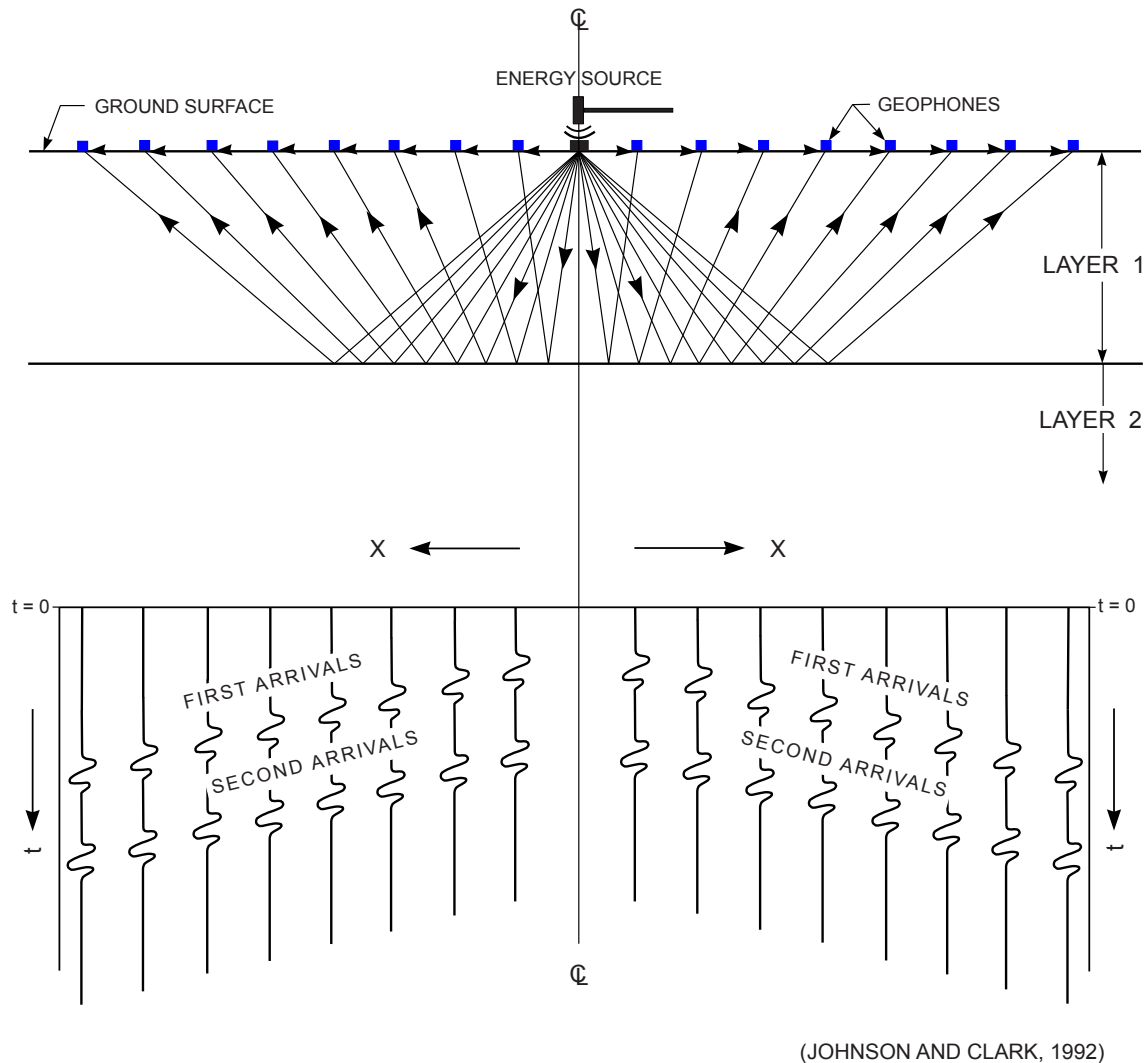

FIGURE 6.17 SEISMIC REFLECTION PRINCIPLE AND SCHEMATIC OF REFLECTION DATA RECORD

nique requires highly experienced practitioners, and no attempt has been made herein to describe the details of the data acquisition, processing and interpretation. Seismic reflection is not commonly used in environmental and engineering projects because of its relatively high cost. Contrary to most other geophysical methods, shallow seismic reflection studies are more expensive than the deep surveys conducted for oil and gas exploration because of the need for closely spaced measurements. Nevertheless, the method offers the potential for defining subsurface structure better than other methods. In cases where it is important to know the location of faults or other lithologic breaks or when the target is a deep abandoned mine working, the high-resolution seismic reflection technique may be the only practical means to obtain the desired data.

Seismic reflection has been applied to mapping the continuity of coal seams in advance of longwall mining, particularly in Europe where mines are commonly at depths greater than 1000 feet and it is difficult and expensive to characterize a coal seam with borings (D'Appolonia, 1982). The method has also been successfully applied to the mapping of mine voids (Clark et al., 1994; Johnson et al., 2002), but the experience base is limited and few practitioners are equipped to properly conduct this type of survey. An example of a high-resolution seismic reflection survey performed over shallow mine workings is presented in [Figure 6.18](#).

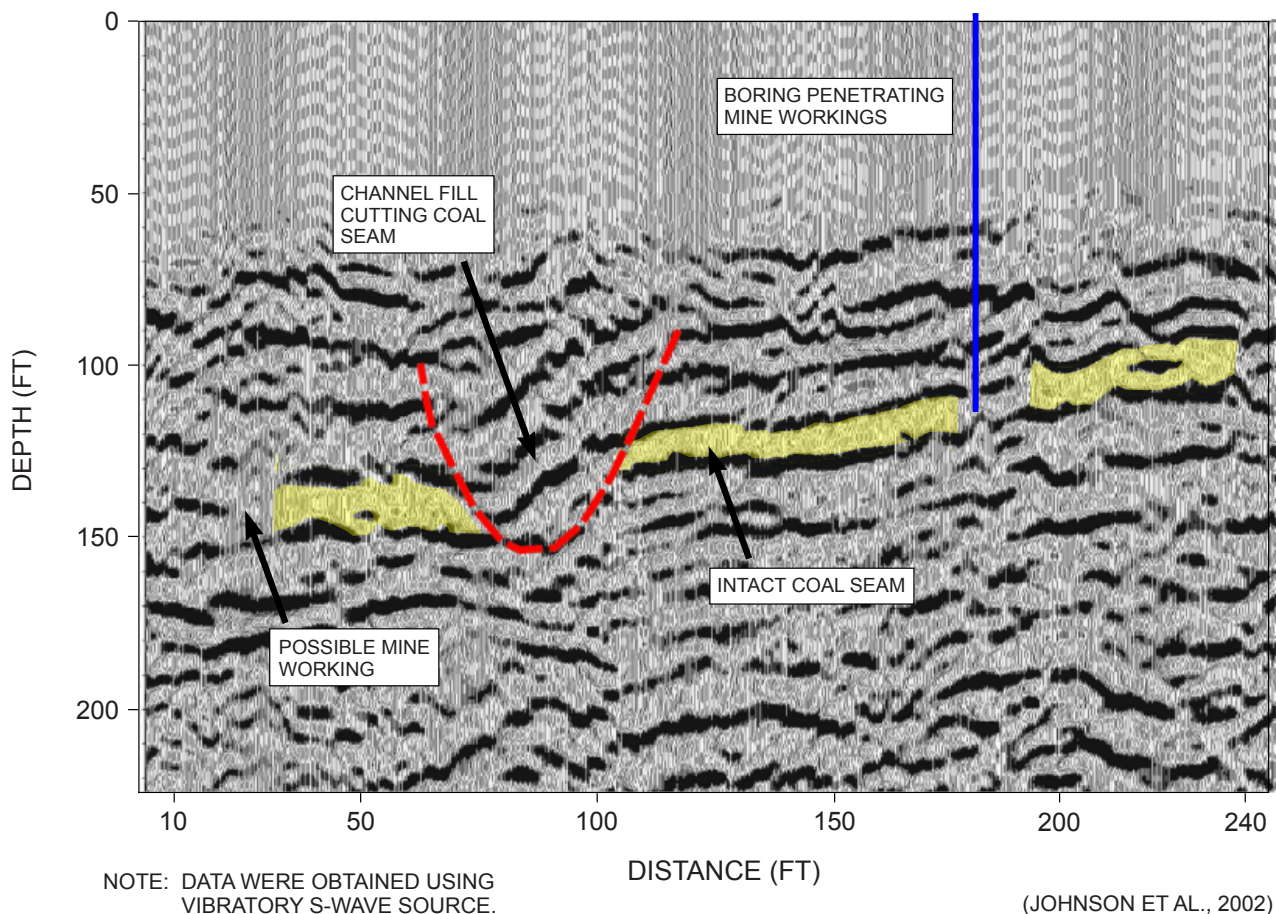
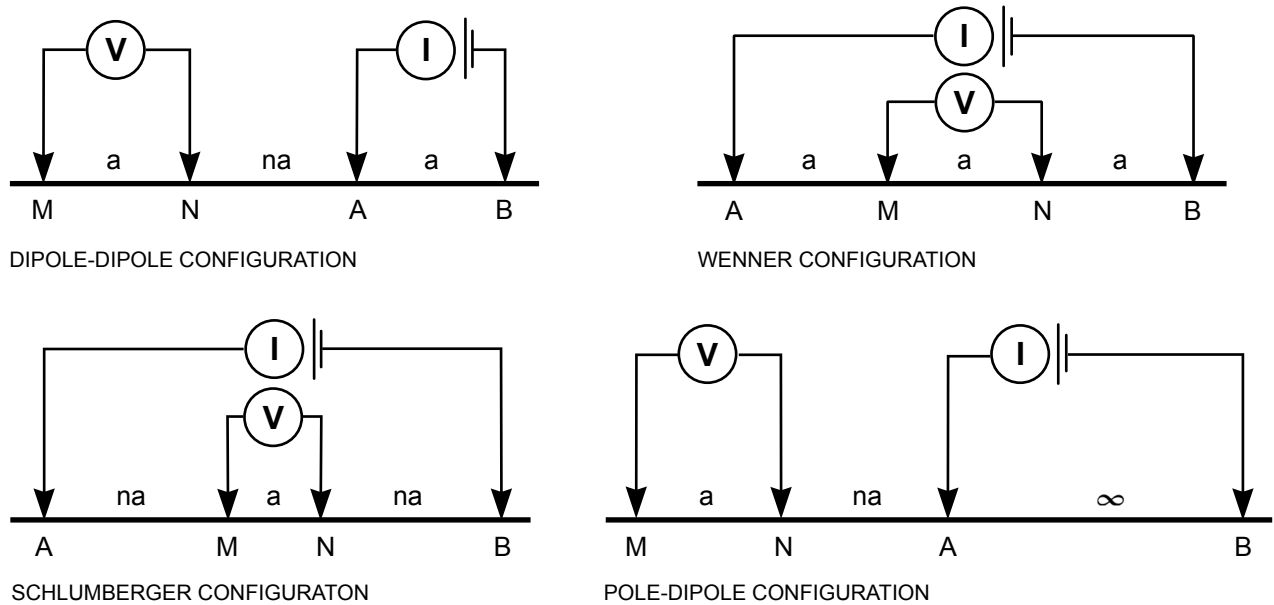

FIGURE 6.18 SEISMIC REFLECTION SURVEY PROFILE OVER ABANDONED COAL MINE WORKINGS

6.4.4.1.3 Electrical Resistivity

The purpose of electrical resistivity surveying is to determine the subsurface resistivity distribution by making measurements at the ground surface. From these surface measurements, the true resistivity of the subsurface can be estimated, and variations or anomalies in the observed resistivity may indicate limits of surface deposits such as coal refuse, the bedrock surface, or flooded mine workings. Resistivity is typically described in units of ohm-meters or ohm-feet. Ground resistivity is affected by various physical parameters such as the mineral and fluid content, porosity, and the degree of saturation.

The measurement of electrical resistivity is normally performed using four electrodes, two that induce current into the ground and two that measure potential difference (voltage). Figure 6.19 provides some examples of electrode configurations commonly used for electrical resistivity measurements. Electrical resistivity surveys have been performed for many decades as part of hydrogeological, mining and geotechnical investigations, but the use of this technique has recently increased due to improvements in both data acquisition and data processing technologies. Multi-electrode systems have greatly improved the efficiency of data acquisition, as measurements can now be made automatically without moving the current insertion and voltage measurement points. Also, the DC resistivity method had been limited by the need to perform complex calculations to model subsurface electrical properties. With the availability of high-speed personal computers and improved 2D and 3D processing software (Gan; 2004, 2005), the technique has seen increased interest from the mining industry, including as a means for detection of subsurface openings.



NOTE: A AND B ARE CURRENT (I) INSERTION POINTS;
M AND N ARE VOLTAGE (V) MEASUREMENT POINTS.

(ADAPTED FROM GAN, 2004)

FIGURE 6.19 COMMONLY USED ELECTRODE CONFIGURATIONS FOR GROUND ELECTRICAL MEASUREMENTS

At coal refuse disposal sites, electrical resistivity surveys have proven useful for estimating the amount of coal refuse disposed at existing facilities by enabling location of the base of the refuse. Furthermore, the method also has the potential to differentiate zones with varying physical characteristics related to coal content within the coal refuse. An example of the application of electrical resistivity to generate profiles across a fine coal refuse deposit is presented in Figure 6.20. In the figure, the depth to the base of the coal refuse, which is in contact with bedrock, is clearly visible (yellow line), and variations in resistivity within the fine coal refuse can be attributed to physical differences such as the level of coal content.

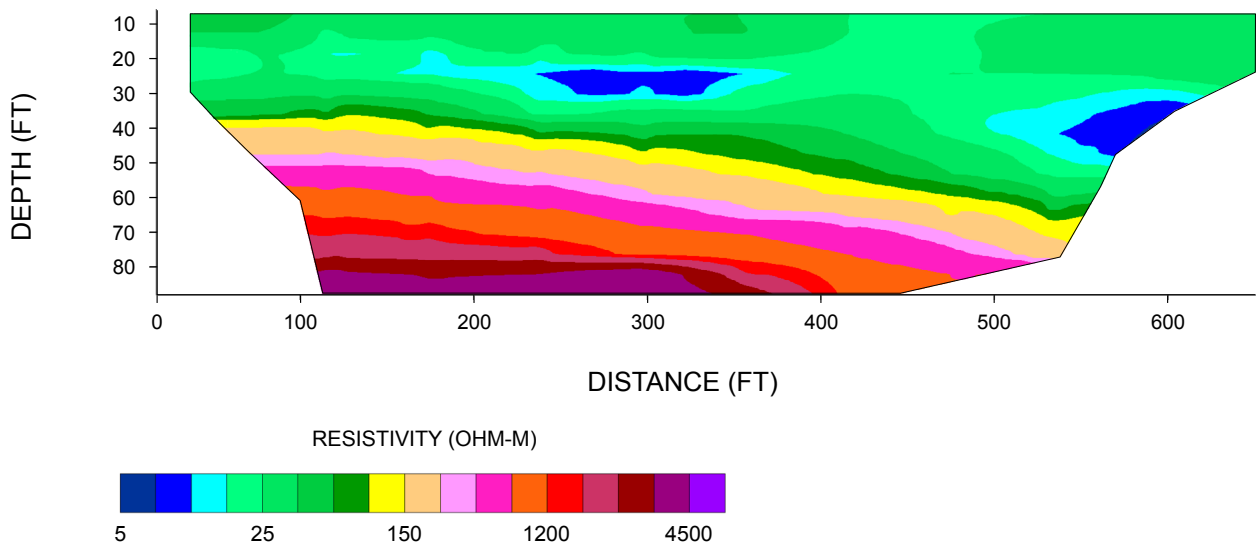

FIGURE 6.20 RESISTIVITY PROFILE ACROSS FINE COAL REFUSE IMPOUNDMENT

Another application of the electrical resistivity method at coal refuse sites is the detection of abandoned mine workings, as shown in Figure 6.21. The ability to detect voids is enhanced when the void has a physical contrast with the surrounding rock. If the void is empty (no water), it will be difficult to detect with electrical measurements. Air does not transmit an electrical current, and, unless the coal has an unusually low resistivity, it may be difficult to distinguish a void. The resistivity contrast between flooded mine voids and typical coal will approach two orders of magnitude (Johnson, 2003), thus allowing for detection of mine workings as resistivity lows. Project experience with electrical resistivity demonstrates that commercially available technology can be effective, especially for the detection of flooded mine workings at depths up to about 100 feet (Figure 6.21). D'Appolonia (2006) conducted a demonstration project for MSHA to illustrate the application of the method at the perimeter of an impoundment where abandoned workings in the 40- to 60-foot-depth range contained limited water. For deeper workings, the method has the potential to be effective, but theoretical models and practical experience indicate that the target size/depth ratio needs to be favorable and that the length of the resistivity profile required for acquiring deep images is often limited by surface interference. Therefore, the method is usually most effective for mine subsidence applications.

6.4.4.1.4 Spontaneous Potential (SP)

The spontaneous or self-potential (SP) method consists of measuring naturally occurring electrical potentials (voltage differences) in the subsurface. One of the sources of these electrical potentials is the movement of water through a porous medium, which produces electro-filtration or streaming potentials. These potentials can be used for the evaluation of seepage (Figure 6.22). As water flows through a capillary system, it collects and transports positive ions from surrounding materials. The positive ions accumulate at the exit point of the capillary, leaving a net positive charge. The untransported negative ions accumulate at the entry point of the capillary, leaving a net negative charge. If the streaming potentials developed by this process are of sufficient magnitude to be measured, the entry point and the exit point of zones of concentrated seepage can be determined due to the negative and positive (respectively) SP anomalies.

SP is measured with a pair of non-polarizing electrodes and a high-impedance voltmeter. One of the electrodes is placed in the ground at a convenient location and remains in place throughout the survey. This is referred to as the "base" electrode. It is connected to a multi-meter via an insulated, single-conductor wire mounted on a reel. This wire may be hundreds of meters long. The second

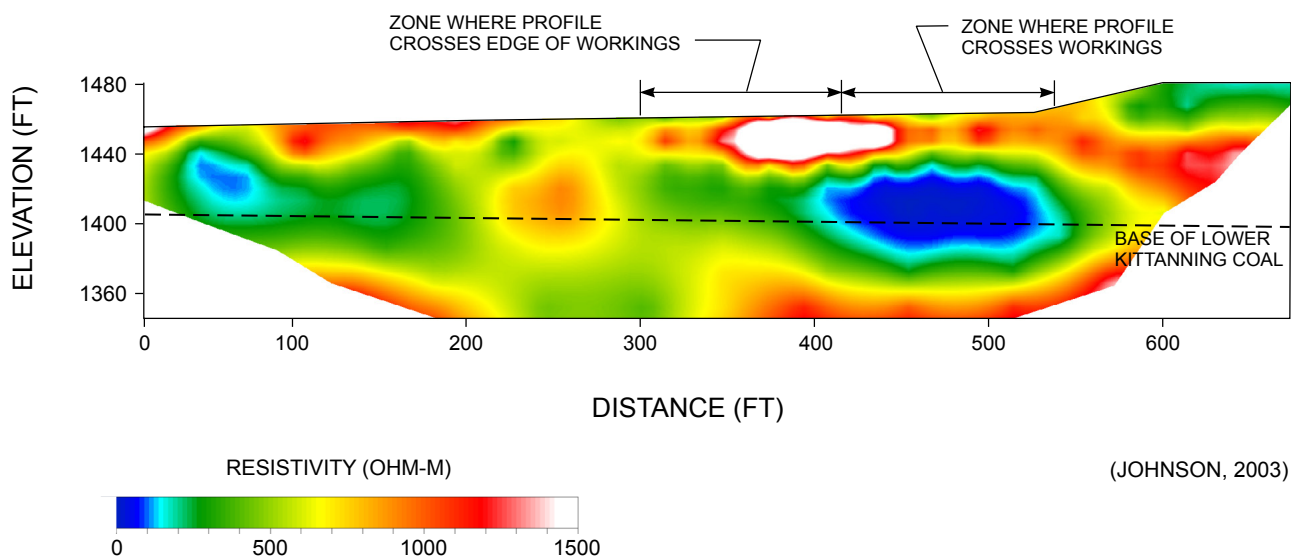

FIGURE 6.21 ELECTRICAL SURVEY OF FLOODED MINE WORKINGS

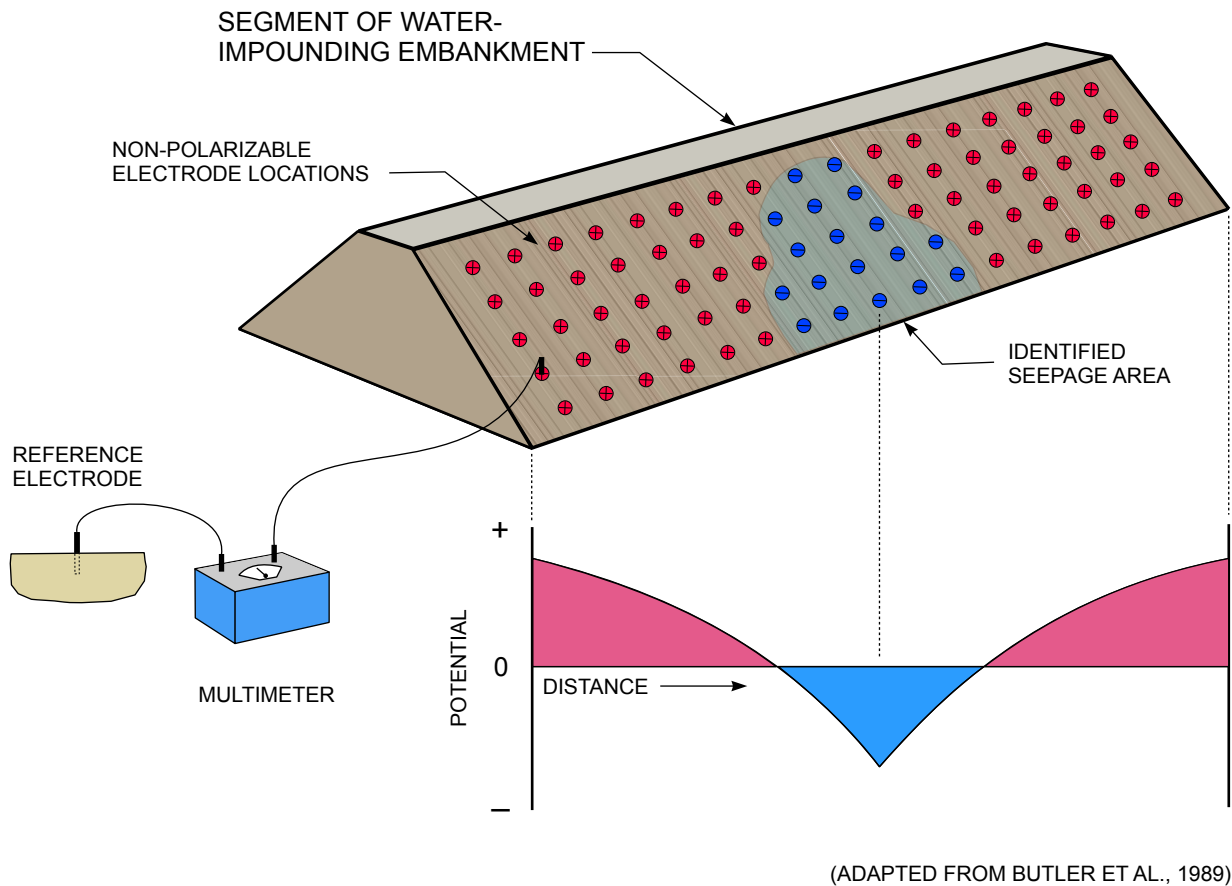

FIGURE 6.22 ILLUSTRATION OF USE OF SP METHOD TO IDENTIFY AN AREA OF SEEPAGE

electrode, or “measuring electrode,” the reel, and the multi-meter are then moved from point to point in a planned grid. At each point of the grid, the electrical potential between the base and the measuring electrode is recorded.

If the potential differences are plotted in profile or contoured to identify zones with negative potential, areas of seepage can be identified. Additional information and examples of SP surveys used to locate seeps in embankment dams and tailings impoundments are provided by Butler et al. (1989), Butler et al. (1990), Bérubé (2004), Song et al. (2005), and Mainali (2006). Recent advances in the SP technique allow for predictive modeling of the SP anomalies associated with seepage, enhancing the interpretability of SP results (UBC-GIF, 2005; Bérubé, 2004).

6.4.4.1.5 Electromagnetics (EM)

Similar to electrical resistivity measurements, electromagnetic methods (EM) allow mapping of the distribution of subsurface electrical properties, except that the EM methods are designed for measurement of variations in conductivity, not resistivity. Resistivity and conductivity are different parameters related to the same physical property and are simply the inverse of one another. As noted above, the unit most commonly used to measure ground resistivity is the ohm-meter (ohm-m). The term “mho” reflects its inverse relationship to the ohm, but was discontinued in favor of the term “siemen” (symbol S) in the late 1970s. The corresponding unit of conductivity is the inverse of an ohm-meter, referred to as a mho (or siemen) per meter, or S/m . The most common unit of conductivity is the $\mu S/cm$, which is $0.0001 S/m$. With this conversion, $10,000 \mu S/cm = 1 S/m = 1 \text{ ohm-m}$.

An advantage of all EM systems as compared to the resistivity method is that it is not necessary to insert electrodes in the ground and thus the surveying is more rapid. Disadvantages of EM methods are: (1) they are generally not as good as the DC resistivity method in resolving variations of electrical properties with depth and (2) they are more subject to cultural interference from electrical lines and metallic objects. For these reasons, EM methods are most commonly used to rapidly measure lateral variations of soil electrical properties, as well as to delineate the distribution of metal objects.

Electromagnetic (EM) techniques can be grouped into active methods, where an active EM signal is induced in the ground by human activity, and passive systems, where measurements are made of natural variations of the earth's EM field. Active systems are further grouped into frequency domain and time domain. Passive systems include very low frequency (VLF), and magnetotelluric methods. McNeill (1990) provides a discussion of various EM techniques.

EM methods have potential application for characterization of coal refuse sites (e.g., mapping abandoned workings) as long as the workings are flooded. For example, time-domain EM (TDEM) measurements have been used to map flooded workings, as shown in [Figure 6.23](#). Where this technique has been attempted over workings that are not flooded, the method was less successful (MSHA, 2008). EM techniques that measure bulk ground conductivity are commonly used at operating or abandoned refuse disposal facilities to determine the migration of contaminated groundwater or to delineate the extent of waste deposition. EM techniques can also be used to characterize variations in the physical properties of existing coal refuse deposits related to coal content. Results of this type of survey with a commonly-used conductivity meter (Geonics EM-31) over an existing coal refuse deposit are shown in [Figure 6.24](#). The plan location of the resistivity profile in [Figure 6.20](#) is shown in [Figure 6.24](#). In this example, the EM survey provides mapping of the near-surface horizontal variations of the coal refuse, while the resistivity profile in [Figure 6.20](#) shows vertical variations.

6.4.1.1.6 Ground Penetrating Radar (GPR)

Ground penetrating radar (GPR) has evolved over the past two decades into one of the most commonly applied techniques for imaging the shallow subsurface. The method offers the highest resolution of geophysical techniques commercially available today. In many cases, the time required for the acquisition of GPR profiles is minimal, and subsurface profiles can normally be generated in real time, making this tool very cost-effective. GPR works best in non-conductive soils, such as dry sand or sand saturated with fresh water.

The typical result of a GPR survey is a profile that presents radar wave amplitude as a function of distance along the line and two-way travel time. To determine the depth to a reflector, it is necessary to know the average propagation velocity from the ground surface. The velocity of a radar pulse in an earth material is dependent on the relative dielectric constant (ϵ_r) of the material according to the following relationship:

$$V = c / (\epsilon_r)^{0.5} \quad (6-5)$$

where:

- V = velocity in propagating material (m/sec)
- c = speed of light (m/sec)
- ϵ_r = relative dielectric constant (dimensionless)

This velocity can sometimes be estimated from the characteristics of the subsurface lithology. [Table 6.25](#) presents typical velocities in terms of two-way travel time (nanoseconds/meter) for various earth materials along with their approximate relative dielectric constants.

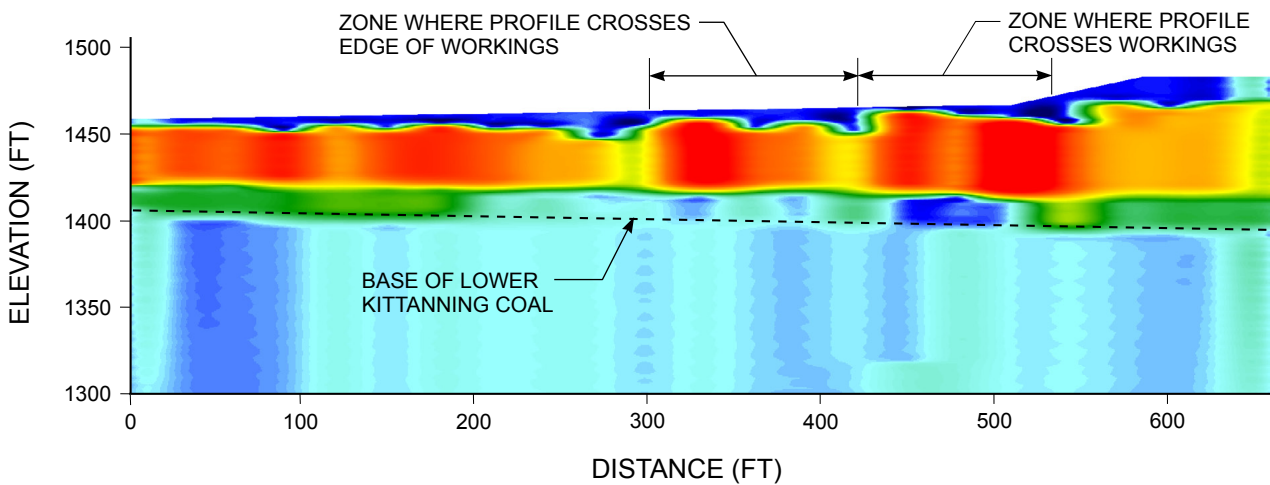

FIGURE 6.23 DELINEATION OF FLOODED MINE WORKINGS WITH TDEM METHOD

Until the advent of commercial systems with separate transmitting and receiving antennas, depth estimation based on subsurface material properties or from observations from reflectors of a known depth was the only means to interpret a GPR profile. Modern systems with the ability to record reflections at varying distances from the transmitting antenna allow for the calculation of the subsurface velocity profile by means of a normal moveout (NMO) correction based on hyperbolic reflections from subsurface features.

Depth of penetration depends on the selection of an appropriate antenna frequency. An antenna frequency of one gigahertz would be suitable for mapping rebar in concrete, but would only have at most a few feet of penetration in typical soil. Most GPR surveys in soil use antennas with frequencies

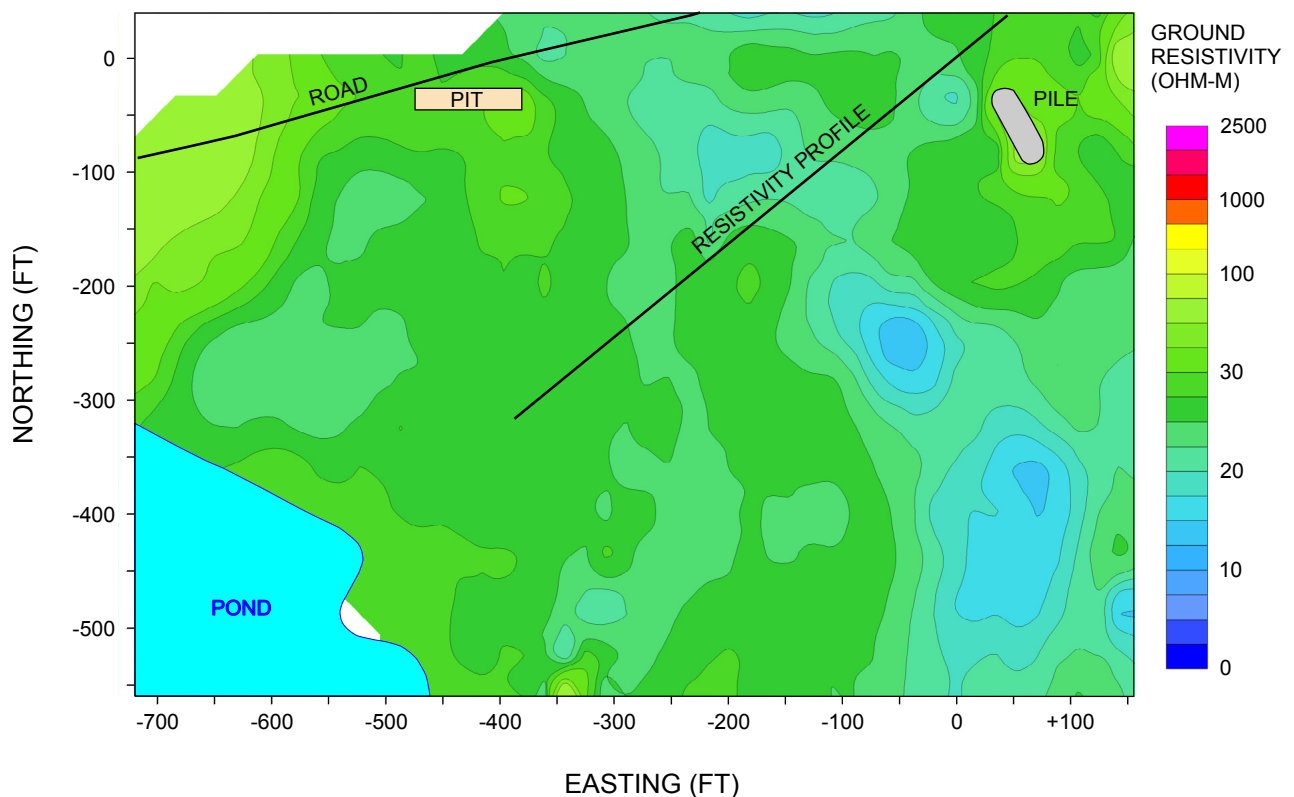

FIGURE 6.24 RESISTIVITY OF COAL REFUSE FROM EM-31 MEASUREMENTS

TABLE 6.25 PHYSICAL PROPERTIES AND TYPICAL GROUND PENETRATING RADAR VELOCITIES FOR COMMON EARTH MATERIALS

Material	Approximate Conductivity (mS/m)	Approximate Relative Dielectric Constant ϵ_r (dimensionless)	Two-Way Travel Time (sec $\times 10^{-9}$ /m)
Air	0	1	6.6
Fresh Water	$10^{-1} - 30$	81	59
Fresh-Water Ice	$10^{-1} - 10$	4	13
Permafrost	$10^{-2} - 10$	4 - 11	13 - 15
Limestone	$10^{-6} - 1$	6 - 8	22
Granite	$10^{-6} - 1$	5.6 - 8	18.7
Dry Sand	$10^{-4} - 1$	4 - 6	13 - 16
Saturated Sand (fresh water)	$10^{-1} - 10^2$	30	32 - 36
Saturated Silt (fresh water)	$10 - 10^2$	10	21
Saturated Clay (fresh water)	$10^2 - 10^4$	8 - 25	18.6 - 23
Average "Dirt"	$10^{-1} - 10^2$	16	20 - 30

(BENSON ET AL., 1984)

between about 100 and 400 MHz, with the greatest penetration achieved with the 100-MHz antenna, but with a substantial loss of resolution as compared to the 400-MHz antenna.

Another factor affecting the depth of penetration of the GPR signal is attenuation. Attenuation is caused by spreading and scattering losses, as well as electrical losses. Scattering and electrical losses are due primarily to the conductivity of the subsurface materials, which in soils relates mainly to clay and moisture content. In dry sand, penetration can reach as much as 50 to 70 feet. In wet, saturated clay penetration may be as little as 3 to 7 feet.

The main limitation of the GPR technique is depth of penetration under conditions commonly encountered in areas with coal workings. The soils commonly encountered in coal mining areas are clays weathered from the claystones associated with the sedimentary sequences that include the coal, and these soils can severely restrict the effective penetration of the radar waves. Thus, use of GPR is generally limited to the identification of near-surface features such as buried waste, pipes, etc. Nevertheless, where abandoned mine workings are shallow, GPR can sometimes be used to detect these workings. An example of a GPR record with identified mine workings is shown in [Figure 6.25](#).

6.4.4.1.7 Gravity

At mine sites the gravity method can detect shallow abandoned mine workings by measurement of minute changes in the earth's gravity field resulting from the lack of near-surface mass associated with mine openings. The measurement of the gravity field for this application is referred to as microgravimetry and requires the use of specialized gravimeters with a sensitivity of one microgal (approximately one billionth of the earth's gravity field). An air-filled mine void would in theory be detectable with commercial equipment at a depth of about 30 feet. In practice, it is time-consuming to acquire the data, and accurate elevation control is needed, and it is desirable to have a topographic survey crew accompany the geophysicist to measure the precise elevation of the instrument at each reading point. For a target as shallow as 30 feet, the surface width of the gravity anomaly is about 100 feet. Thus, a survey requires a significant amount of accessible space, which is often not avail-

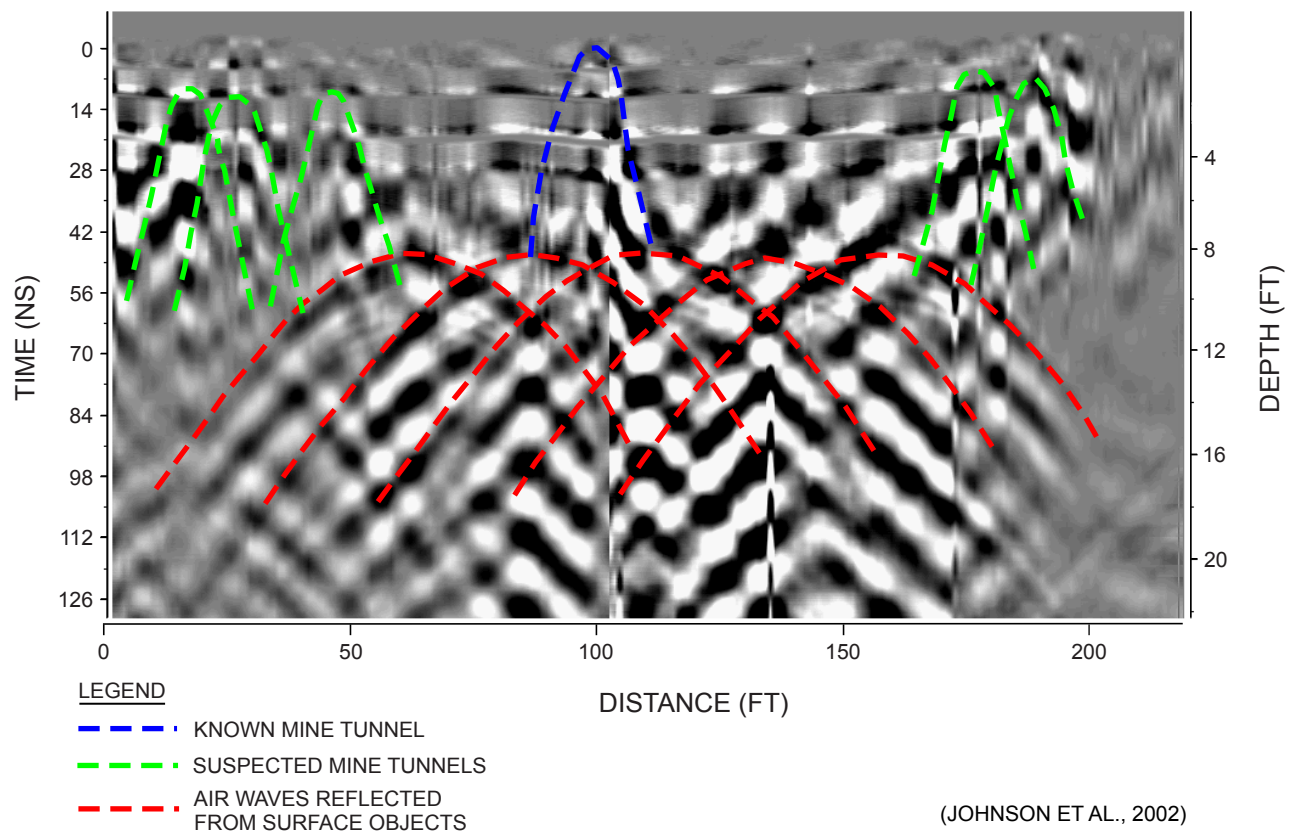

FIGURE 6.25 GPR RECORD OF SHALLOW COAL MINE WORKINGS

able. Furthermore, it is often difficult to correct the gravity data for variations caused by surrounding topography, instrumental drift, and elevation. In particular, micro-topographic changes can significantly affect gravity readings. Unless the target is in a flat, open area and the depth does not exceed about 40 to 50 feet, the gravity method will probably not be practical. Nevertheless, if the mine workings are expected to be very shallow and air-filled, the gravity method is one of the few geophysical methods that can provide conclusive evidence of the presence of a mine void. A theoretical gravity response over an air-filled mine void is presented in [Figure 6.26](#).

6.4.4.1.8 Magnetics

The primary application of the magnetic method in a coal refuse environment is the detection of metal, including abandoned metal well casings. Measurements are made by an instrument called a magnetometer, and the unit of magnetic intensity is the nanotesla (nT), sometimes referred to as a gamma. Differences in the normal value of the earth's magnetic field correspond to magnetic anomalies that can be measured with a magnetometer. Surveys for well casings can be conducted from the ground or from the air, as previously noted. As shown in [Figure 6.27](#), well casings produce very strong anomalies, detectable even when the magnetometer is located at an elevation of 250 feet above the well casing. The potential for detecting abandoned mines is minimal, unless mine openings are associated with metal, as might be the case if old mine rails are present. Coal has a low magnetic susceptibility when compared to most other rocks. A void in a coal seam, therefore, will not produce a significant disturbance to the earth's natural magnetic field, but a sensitive magnetometer can detect old mine rails at a depth of several tens of feet.

6.4.4.2 Borehole Geophysical Techniques

Borehole logging includes numerous geophysical techniques involving the lowering of sensing devices into a borehole and continuously recording physical parameters associated with the sur-

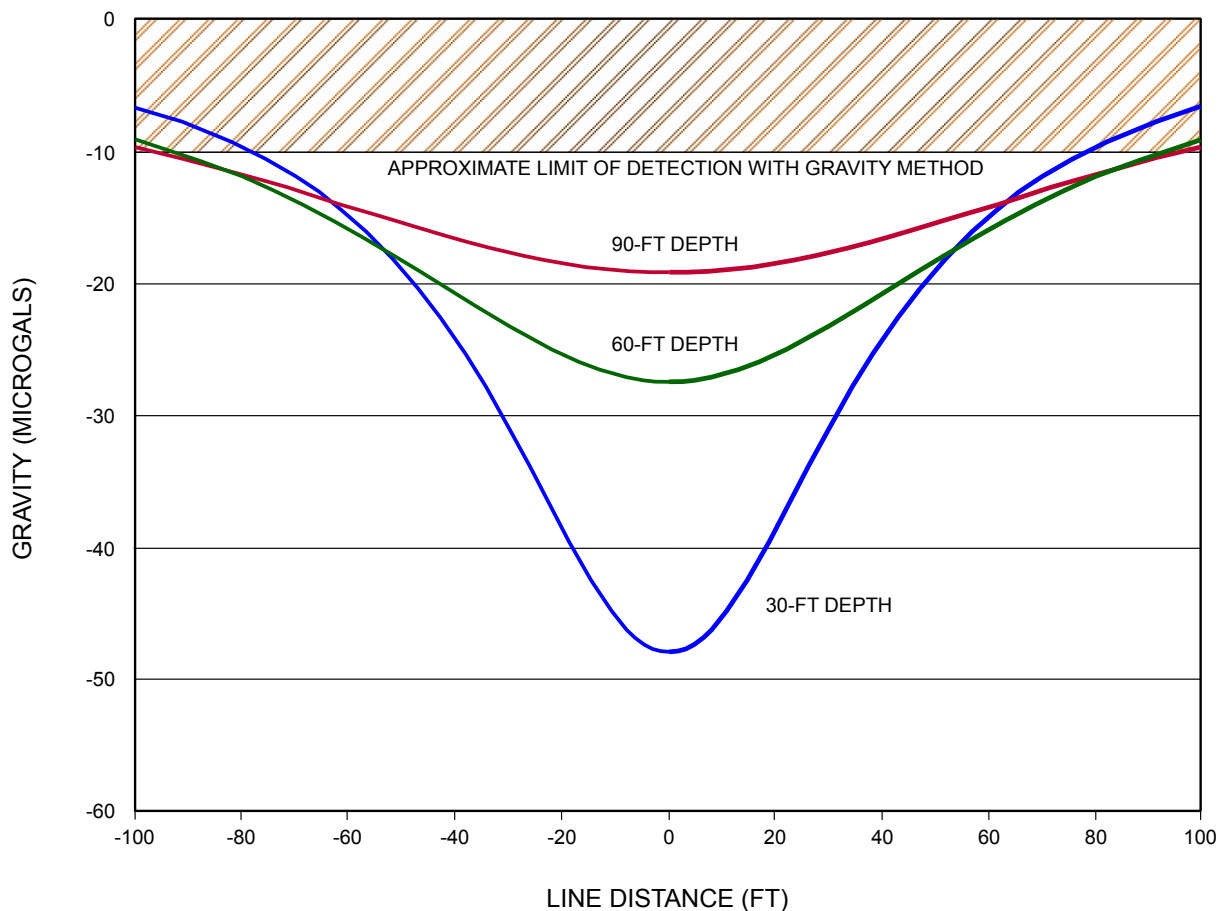

NOTE: RESPONSE WOULD BE APPROXIMATELY ONE-THIRD OF THE ABOVE FOR A WATER-FILLED TUNNEL.

(JOHNSON ET AL., 2002)

FIGURE 6.26 THEORETICAL RESPONSE OF GRAVITY GEOPHYSICAL METHOD OVER 20-FOOT-DIAMETER, AIR-FILLED TUNNEL

rounding rock, soil, pore fluids, or other physical parameters. The FHWA lists 23 borehole logging techniques on their web site.

A general grouping of the most commonly applied borehole techniques is provided in ASTM D 5753, "Standard Guide for Planning and Conducting Borehole Geophysical Logging." This general grouping of borehole geophysical techniques is shown in Table 6.26, where a division is made in terms of: (1) acoustic logs intended to determine ground variations related to seismic velocity, (2) electrical and induction logs that identify lithologic and groundwater variations on the basis of resistivity/conductivity, (3) nuclear logs that relate to variations in natural or induced radioactivity, and (4) miscellaneous techniques that define the physical characteristics of boreholes and/or voids penetrated by boreholes.

For coal refuse facilities, most of the commonly used borehole geophysical methods are suitable for general site characterization in combination with conventional drilling and sampling. Techniques with particular relevance to coal refuse disposal facilities are those that provide the S-wave velocity as a function of depth (crosshole and downhole seismic methods), because this information is useful for the evaluation of the potential for seismically-induced liquefaction. Borehole logging and techniques that have potential for characterization of abandoned mine workings (video, laser imaging, sonic imaging) are also directly applicable to coal refuse disposal facility evaluations.

A borehole technique with the potential for imaging abandoned mine workings is borehole GPR. Mine voids within approximately 10 ft can be detected from borehole GPR. Research has shown that crosshole GPR tomography can identify tunnels, but this is not a commonly applied technique and the difficulties of this technique in mapping coal mine voids is well described by the Colorado School of Mines in an experimental mine detection study for MSHA (CSM, 2007).

Information on commonly applied general borehole geophysical techniques can be found in USEPA (1993), USACE (1995a), Keys (1997), Sabatini et al. (2002), Wightman et al. (2003), and Sirles (2006). The following discussion focuses on techniques for measuring S-wave velocity that are primarily used for determining the seismic properties of coal refuse and soils for liquefaction analyses, but these techniques may also be useful for characterizing mine voids.

6.4.4.2.1 Crosshole and Downhole/Uphole Seismic Surveys

Crosshole and/or downhole/uphole seismic testing in boreholes is conducted for determining soil and rock properties (P- and S-wave velocities). The information obtained from these tests can be used to compute shear modulus, Young's modulus, and Poisson's ratio for use in static/dynamic analyses. The basic relationships are as follows:

$$E = \rho V_p^2 \left[\frac{(1 + \nu)(1 - 2\nu)}{1 - \nu} \right] \quad (6-6)$$

$$G = V_s^2 \rho \quad (6-7)$$

where:

V_p = compressional (P-wave) velocity (length/time)

V_s = shear (S-wave) velocity (length/time)

E = Young's modulus (force/length²)

G = shear modulus (force/length²)

ρ = mass density of soil (mass/length³)

ν = Poisson's ratio of soil (dimensionless)

If both V_p and V_s are known, the Poisson's ratio of the soil can be determined from the following relationship between E and G :

$$G = E / 2 (1 + \nu) \quad (6-8)$$

With borehole seismic surveys, one or more boreholes are drilled into the soil to the desired depth of exploration. Wave sources and/or receivers (borehole geophones normally oriented to record both horizontal and vertical components of wave motion) are then lowered into the boreholes. There are three basic approaches to borehole seismic surveys:

- **Crosshole Survey** – In a crosshole survey, the energy source is located in one borehole and detectors are placed in another borehole at the same depth as the energy source. The energy source is usually a mechanical pulse instrument composed of a stationary part and a hammer. The pulse instrument is held against the side of the borehole by a pneumatic or hydraulic bladder. Travel times between the source and receivers are measured, allowing determination of wave velocities.
- **Uphole Survey** – Geophones are laid out on the ground surface in an array around the borehole. The energy source is set off within the borehole at successively decreas-

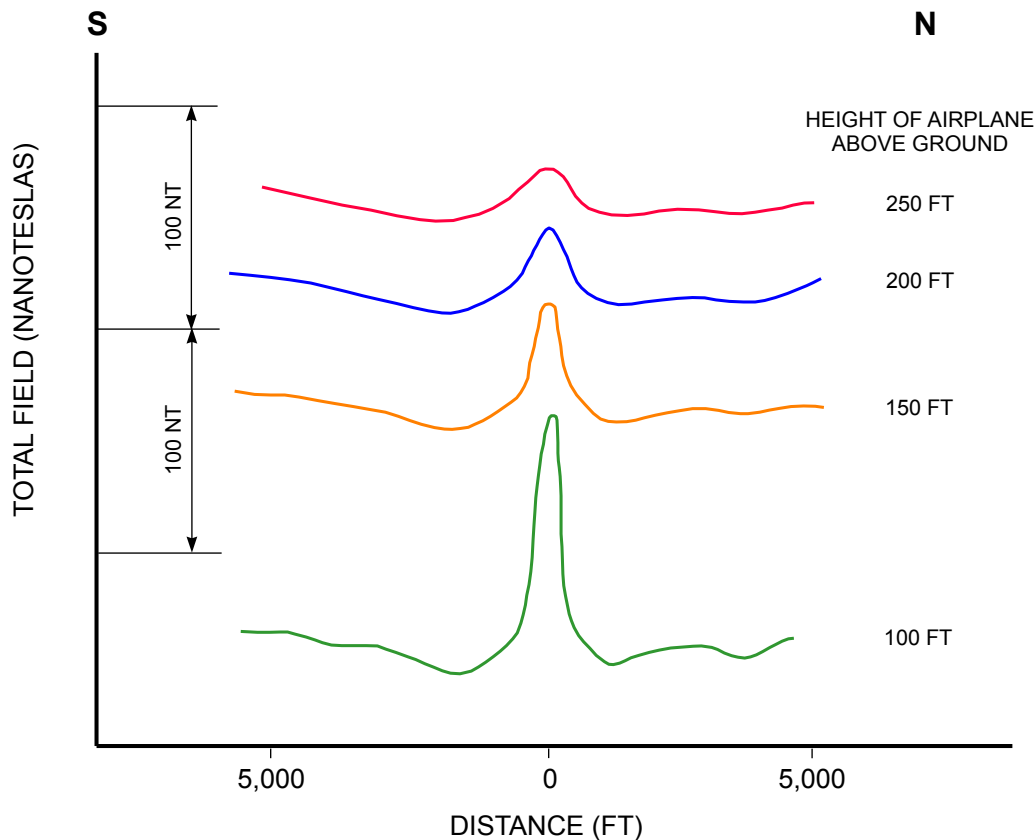

(FRISCHNECHT AND RAAB, 1984)

FIGURE 6.27 MAGNETIC INTENSITY RECORDED AT VARIOUS HEIGHTS ABOVE WELL CASING

ing depths starting at the bottom of the hole. The travel times from the source to the surface are analyzed to determine the wave velocity versus depth.

- Downhole Survey – In a downhole survey, the energy source is located on the surface and a detector (geophone) is placed in a borehole. The travel time is measured with the geophone placed at progressively increasing depth, and a wave-velocity profile is generated.

Crosshole seismic surveys involve measurement of the travel time of seismic energy transmitted between two or preferably three boreholes to derive information relative to the elastic properties of the intervening materials. The travel times of the seismic waves are derived from the identified first-arrivals of the P- and S-waves on the seismic trace for each shot-receiver position and are used with the known distance (s) between the shot/receiver boreholes to calculate the apparent velocities (P- and S-wave) for each depth interval. The borings are usually cased and grouted to the surrounding soil/rock. PVC casing is normally used for the tests, so that the casing is not a seismic pathway. A typical field setup for a crosshole seismic survey is shown in [Figure 6.28](#).

Crosshole geophysical testing is described in ASTM D 4428, “Standard Test Methods for Crosshole Seismic Testing.” Crosshole measurements are generally preferred to downhole measurements because they provide higher resolution and greater accuracy. However, the distances between the energy source and the detector must be measured precisely. An inclinometer survey is generally performed in crosshole test boreholes to correct the data for deviation of the boreholes from vertical. To calculate P- and S-wave velocity, the wave arrivals must be processed with a computer program that accounts for situations where the waves may be refracted between the boreholes according to Snell’s Law. The data are then used to develop vertical profiles of the various elastic moduli.

TABLE 6.26 APPLICABILITY OF COMMON BOREHOLE GEOPHYSICAL METHODS

Borehole Geophysical Method	Dependent Physical Property	Application (see key below)									
		1	2	3	4	5	6	7	8	9	10
<u>Acoustic Logs</u>											
In-hole acoustic velocity	Elastic moduli, density	A-2	A-2	X	X	A-2	X	A-2	X	X	X
Crosshole S-wave velocity	Elastic moduli, density	A-4	X	X	X	M	X	X	X	X	M
Downhole S-wave velocity	Elastic moduli, density	A-4	X	X	X	M	X	X	X	X	M
<u>Electric and Induction</u>											
Spontaneous potential	Potential difference	A-2	X	X	X	A-2	X	X	X	X	X
Single-point resistance	Resistance	A-2	X	X	X	A-2	X	A-2	X	X	X
Multi-electrode resistivity	Resistivity	A-2	X	A-2	X	A-2	X	A-2	X	X	X
Induction	Conductivity	A-4	X	A-4	X	M	X	X	X	A-4	X
<u>Nuclear</u>											
Gamma	Gamma radiation	A-6	A-6	X	X	X	X	X	X	X	X
Gamma-gamma	Density	A-6	X	A-6	X	A-6	A-6	X	X	X	X
Neutron	Hydrogen content	A-6	X	A-6	X	A-6	X	X	X	X	X
<u>Fluid logs</u>											
Borehole fluid characteristics	Resistivity/ conductivity	X	A-5	X	A-5	A-5	X	X	X	X	X
Fluid flow	Velocity	X	A-5	X	X	X	X	X	X	A-1	X
Temperature	Temperature	X	A-5	X	A-5	A-5	X	X	X	A-1	X
<u>Miscellaneous</u>											
Borehole deviation	Inclination	X	X	X	X	X	X	X	X	A-6	X
Video	Visual characteristics	M	X	X	M	A-6	X	X	A-6	4	A-6
Laser imaging	Physical dimensions	X	X	X	X	X	X	X	X	X	A-3
Sonic imaging	Physical dimensions	X	X	X	X	X	X	X	X	X	A-2
Caliper	Physical dimensions	X	X	X	X	X	X	X	A-3	A-3	M

Applications Key

- | | |
|------------------------------|---|
| 1. Lithology and correlation | 6. Bulk density |
| 2. Hydraulic Conductivity | 7. Rock structure |
| 3. Porosity | 8. Borehole parameters |
| 4. Fluid properties | 9. Elastic properties of coal refuse, soil and rock |
| 5. Depth to groundwater | 10. Characterization of mine workings or other subsurface voids |

Technique Applicability and Required Hole Conditions

- | | |
|---|--|
| A-1 Applicable (cased, fluid-filled hole) | A-5 Applicable (screened or uncased, fluid-filled hole) |
| A-2 Applicable (uncased, fluid-filled hole) | A-6 Applicable (any hole condition, but fluid must be clear for video) |
| A-3 Applicable (uncased, dry hole) | M May be applicable, but probably not the best approach |
| A-4 Applicable (open or fluid-filled hole, non-conductive casing) | X Not applicable |

(ADAPTED FROM USACE, 1995)

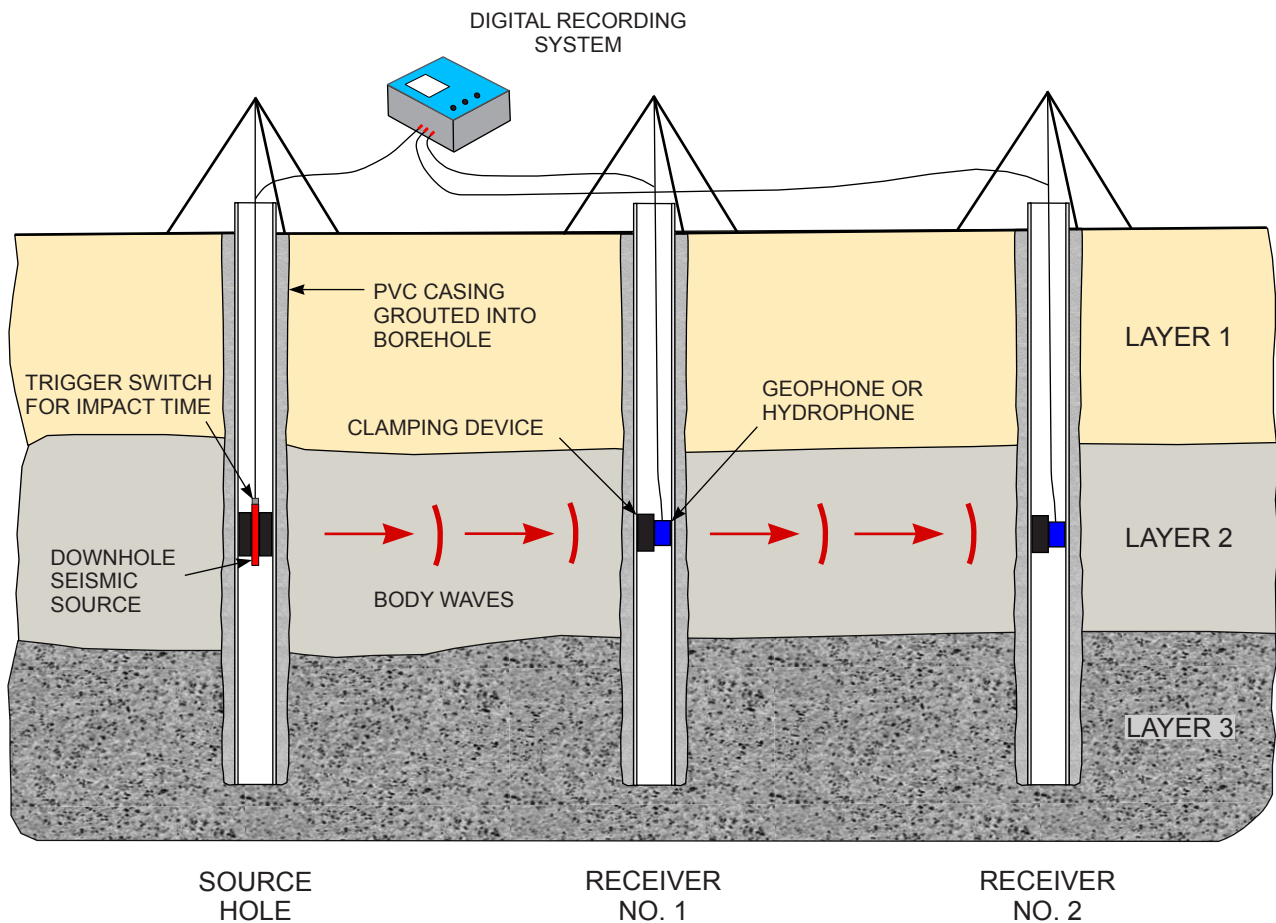

NOTE: THE SEISMIC WAVES GENERATED MAY BE P-, SV-, OR SH BODY WAVES DEPENDING UPON THE TYPE OF SOURCE EMPLOYED.

(SIRLES, 2006)

FIGURE 6.28 FIELD SETUP FOR CROSSHOLE SEISMIC SURVEY

The uphole and downhole techniques are more economical alternatives to the crosshole technique because only one borehole is required. Downhole measurements are not as accurate as crosshole measurements, especially if the layers of interest are thin. However, if critical thin layers are not present, downhole and uphole measurements may be the preferred means for determining the variation of the P- and S-wave velocities with depth. Downhole surveys are generally preferred to uphole surveys, because it is usually more practical to induce a strong seismic signal at the surface than it is in a borehole. Figure 6.29 depicts the deployment for a downhole seismic survey. In terms of analysis, the downhole or uphole methods differ from the crosshole method in that it is necessary to calculate incremental velocities on the basis of differences in travel time between geophones at varying depths rather than from direct pathways.

Seismic tomography employing surveys from boreholes can be used as a tool for detecting abandoned mines. A vertical seismic profile (VSP) can be developed by deploying geophone sensors in a borehole and a seismic source at multiple surface locations. An emerging technology whereby a drill bit is used as a downhole source and seismic waves are recorded at the surface is referred to as reverse vertical seismic profile (RVSP). Although these techniques are generally available and are used in the oil and gas industry, they are rarely applied to investigations at coal refuse facilities because of their relatively high cost. Nevertheless, there is some experience in the application of these techniques as documented by the Colorado School of Mines (2007) and Gritto (2003).

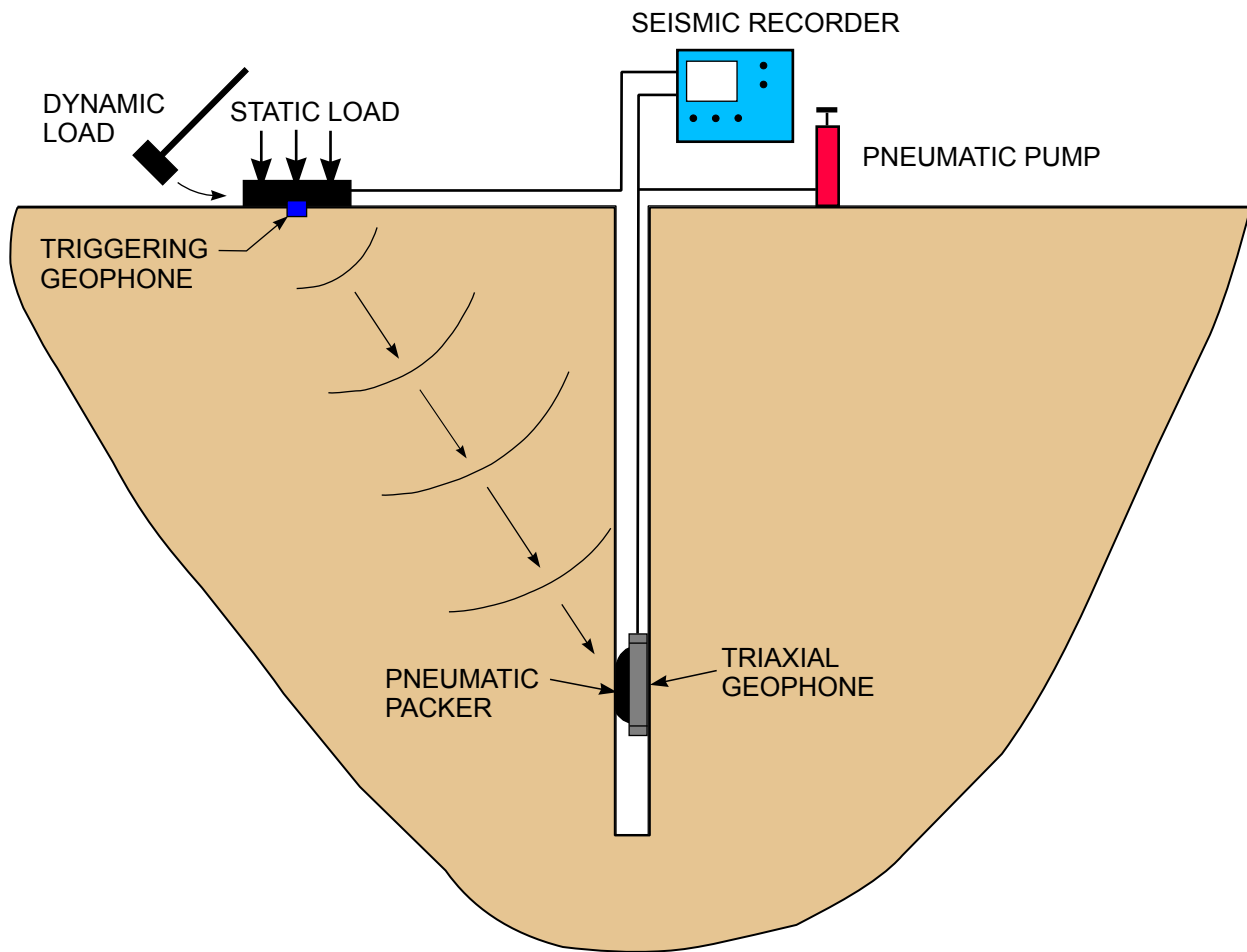

FIGURE 6.29 FIELD SETUP FOR DOWNHOLE SEISMIC SURVEY

A specialized application of a cross borehole technique to identify mine voids is seam wave seismic. Because coal typically has a relatively low seismic velocity compared to the rock formations that confine coal seams, seismic waves can become “trapped” in a coal seam and propagate over long distances with relatively little attenuation if the coal is continuous. Conversely, obstructions to a coal seam such as abandoned mine workings will prevent the propagation of a seam wave. D’Appolonia (1982) describes the use of this technique, but since the publication of this report, seam wave technology has only rarely been used due to the expense and difficulty in interpreting the results. Additional discussion of this technology is provided by Marshall Miller & Associates (MM&A, 2006) and Pennsylvania State University (2006).

6.4.4.2.2 Video and Laser/Sonar Imaging

Imaging of portions of abandoned mine workings can be critical to an understanding of the orientation and condition of these mine workings with respect to an existing or planned coal refuse facility. Video imaging with a borehole camera is a mature technology that also allows for the identification of fractures and collapse zones from a borehole. A disadvantage of using a borehole video camera in an abandoned mine is that it is difficult to image very far into the mine because of lack of light. Another disadvantage is that only visual data are obtained, and it is often difficult to determine distances because of a lack of scale.

If a mine is not flooded, an alternative means to image abandoned workings is a laser, range-based geometric scanner inserted through a dry borehole. Once deployed into a mine void space, a pan and

tilt sequence is initialized, producing a scan of the void. The collected data set is then converted in the field into a 3D point cloud model of the void. The point cloud model is then converted into a 3D mesh model of the underground space. These data can subsequently be processed to produce plan views, sectional views, and volume estimations. Figure 6.30 is a 2D image of a mine entry obtained from a borehole laser scanner, and Figure 6.31 is a 3D laser image of mine workings.

If a mine is submerged, it is still possible to image mine openings with a submersible, sonar, range-based scanner inserted into a borehole. Data collected can be oriented using an on-board compass. Through correlation of several scans at varying elevations, it has proven practical to prepare 3D models of the flooded space.

6.5 MATERIAL PROPERTY DETERMINATION THROUGH TESTING

Accurate and reliable laboratory soil, rock and materials testing requires selection of the appropriate tests and care in sample preparation and performing the tests. Laboratory test results must be carefully interpreted, based upon the: (1) sampling and testing procedures, (2) types of soil and rock at the site, (3) geologic history of the site, and (4) types of coal refuse present and their possible use in refuse disposal facility construction. Suggested references for soil, rock and materials testing procedures include the most current ASTM standards, Mayne et al. (2002), Bardet (1997), and Head (1980, 1982, 1986)

Careful work and attention to detail in laboratory testing are important if accurate and representative results are to be obtained. This is true for all soils, but it is especially important for soils whose structure or fabric, and consequently their tested engineering characteristics, can be affected by disturbance. When undisturbed sample tests are to be conducted on fine-grained soils, sample disturbance must be minimized during sampling, transport, storage and testing. Similarly, some rock types (e.g., mudstones and claystones) can degrade following stress relief and exposure to the air following drilling. Such materials should be carefully stored and transported so that their in-situ moisture condition is preserved to the extent possible.

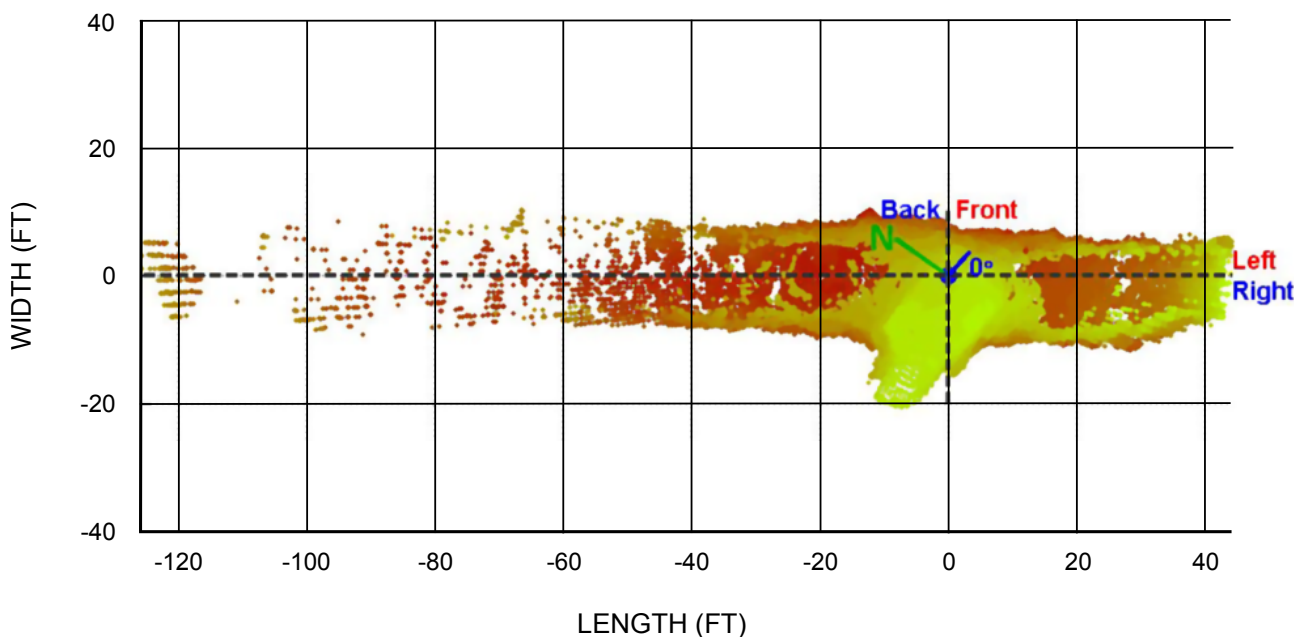

(WORKHORSE TECHNOLOGIES, 2006)

FIGURE 6.30 IMAGE OF MINE ENTRY FROM BOREHOLE LASER SCANNER

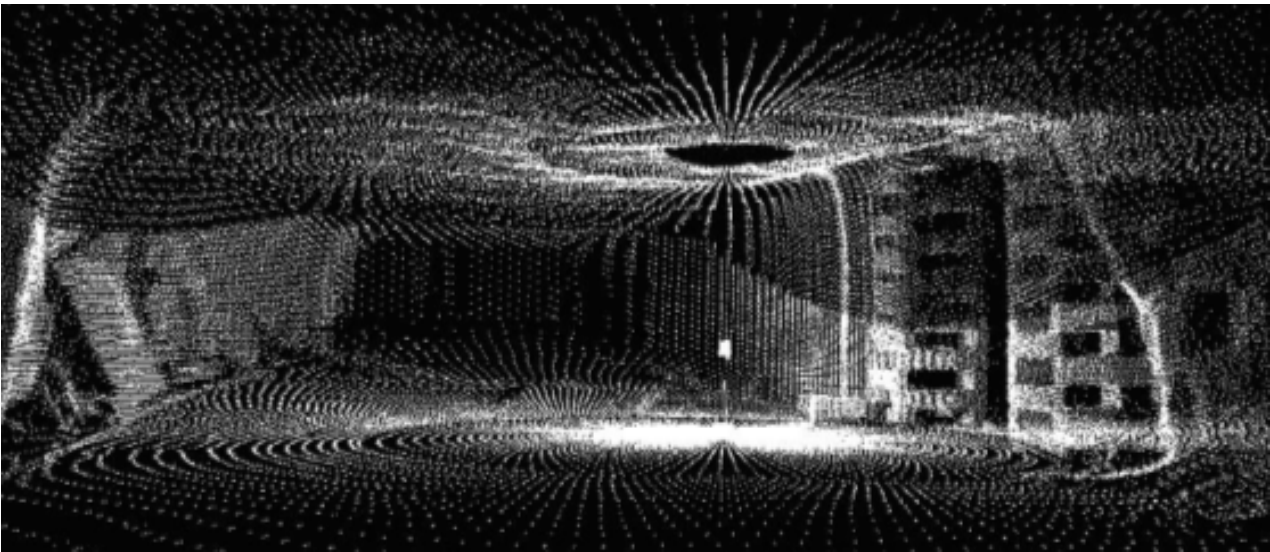

(WORKHORSE TECHNOLOGIES, 2006)

FIGURE 6.31 LASER IMAGE OF MINE WORKINGS

Laboratory tests that provide essential data for the analysis and design of an earthen dam or coal refuse embankment are summarized in [Tables 6.27](#) and [6.28](#). Table 6.27 lists typical soil laboratory tests for site characterization, and Table 6.28 summarizes typical laboratory soil tests applicable to the types of soil, rock and refuse materials used in the construction of embankments and other earth/refuse structures. In most investigations, all of the classification or index property tests listed in the tables should be performed on representative samples. The need for other tests depends upon the purpose and subject of the investigation. The use of test data in the analysis and design of earthen dams and coal refuse impoundments is discussed in Section 6.6.

Standard testing procedures used in soil and rock mechanics are generally applicable to coal refuse, although modifications may be appropriate because of the characteristics of coal refuse. Tests for ash content, pyrite content and leachate water quality, as indicated in Table 6.28, are parameters not included in a typical embankment testing program. However, these parameters may be important in any portion of a disposal facility to be constructed from coal refuse. The ash content is an indication of the amount of coal remaining in the refuse and can be directly correlated with measurements of specific gravity and density. In cases where significant amounts of coal may remain in the refuse, there is a possibility of spontaneous combustion. Knowledge of pyrite content and leachate water quality can facilitate placement procedures that will minimize the potential for environmental impacts.

6.5.1 Selection of Samples for Testing

Samples used for laboratory testing include: (1) bulk and disturbed samples, (2) undisturbed samples, and (3) reconstituted samples. Reconstituted samples are samples created to have characteristics similar to in-situ properties and to meet specified test criteria (e.g., maximum particle dimension cannot be greater than some proportion of the minimum dimension of the test apparatus). The following text describes the three basic types of samples and their possible use for laboratory testing.

6.5.1.1 Bulk and Disturbed Samples

Representative bulk and disturbed samples of soils and refuse materials (for existing refuse disposal facilities) are collected from refuse delivered from the preparation plant, test pit excavations and disturbed sampling (e.g., split-barrel samples) for use in conducting laboratory index (e.g., classification, moisture content, Atterberg limits) and property characterization (e.g., compaction tests and

TABLE 6.27 TYPICAL SOIL AND ROCK LABORATORY TESTS FOR COAL REFUSE DISPOSAL SITE CHARACTERIZATION

Test Category	Test Description	ASTM Designation
Visual Identification	Standard Practice for Description and Identification of Soils (Visual-Manual Procedure)	D 2488
Index Properties	Standard Test Method for Laboratory Determination of Water (Moisture) Content of Soil and Rock by Mass	D 2216
	Standard Test Methods for Specific Gravity of Soil Solids by Water Pycnometer	D 854
	Standard Test Method for Particle-Size Analysis of Soils	D 422
	Standard Practice for Classification of Soils for Engineering Purposes (Unified Soil Classification System)	D 2487
	Standard Test Methods for Amount of Material in Soils Finer than the No. 200 (75- μ m) Sieve	D 1140
Corrosivity	Standard Test Methods for Liquid Limit, Plastic Limit, and Plasticity Index of Soils	D 4318
	Standard Test Method for pH of Soils	D 4972
	Standard Test Method for Measuring pH of Soil for Use in Corrosion Testing	G 51
	Standard Test Method for Sulfate Ion in Water	D 516
	Standard Test Method for Field Measurement of Soil Resistivity Using the Wenner Four-Electrode Method	G 57
Organic Content	Standard Test Methods for Chloride Ion in Water	D 512
	Standard Test Methods for Moisture, Ash, and Organic Matter of Peat and Other Organic Soils	D 2974
	Compaction Test	Standard Test Methods for Laboratory Compaction Characteristics of Soil Using Standard Effort (12,400 ft-lbf/ft ³) (600 kN-m/m ³)
Standard Test Methods for Laboratory Compaction Characteristics of Soil Using Modified Effort (56,000 ft-lbf/ft ³) (2,700 kN-m/m ³)		D 1557
Standard Test Methods for Maximum Index Density and Unit Weight of Soils Using a Vibratory Table		D 4253
Standard Test Methods for Minimum Index Density and Unit Weight of Soils and Calculation of Relative Density		D 4254
Hydraulic Conductivity	Standard Test Method for Permeability of Granular Soils (Constant Head)	D 2434
	Standard Test Methods for Measurement of Hydraulic Conductivity of Saturated Porous Materials Using a Flexible Wall Permeameter	D 5084
Consolidation-Properties	Standard Test Methods for One-Dimensional Consolidation Properties of Soils Using Incremental Loading	D 2435
	Standard Test Method for One-Dimensional Consolidation Properties of Saturated Cohesive Soils Using Controlled-Strain Loading	D 4186

TABLE 6.27 TYPICAL SOIL AND ROCK LABORATORY TESTS FOR COAL REFUSE DISPOSAL SITE CHARACTERIZATION (Continued)

Test Category	Test Description	ASTM Designation
Static Strength Properties	Standard Test Method for Unconfined Compressive Strength of Cohesive Soil	D 2166
	Standard Test Method for Unconsolidated-Undrained Triaxial Compression Test on Cohesive Soils	D 2850
	Standard Test Method for Consolidated-Undrained Triaxial Compression Test for Cohesive Soils	D 4767
	Standard Test Method for Direct Shear Test of Soils under Consolidated-Drained Conditions	D 3080
	Standard Test Method for Laboratory Miniature Vane Shear Test for Saturated Fine-Grained Clayey Soil	D 4648
Cyclic/Dynamic Strength Properties	Standard Test Method for the Determination of the Modulus and Damping Properties of Soils Using the Cyclic Triaxial Apparatus	D 3999
	Standard Test Methods for Modulus and Damping of Soils by the Resonant-Column Method	D 4015
	Standard Test Method for Load-Controlled Cyclic Triaxial Strength of Soil	D 5311
Rock Properties	Standard Test Method for Determination of the Point Load Strength Index of Rock	D 5731
	Standard Test Method for Compressive Strength and Elastic Moduli of Intact Rock Core Specimens under Varying States of Stress and Temperatures	D 7012
	Standard Test Method for Splitting Tensile Strength of Intact Rock Core Specimens	D 3967
	Standard Test Method for the Slake Durability of Shales and Similar Weak Rocks	D 4644

(ADAPTED FROM SABATINI ET AL., 2002)

strength and compressibility testing of reconstituted samples) testing. [Table 6.18](#) provides a summary of common sampling methods for obtaining bulk and disturbed soil samples.

Field personnel directing field sampling activities need to be aware that the quantity of material needed depends on the laboratory tests to be performed, the relative amount of coarse (> 3 inches) particles present, and the size limitations of the test equipment. ASTM D 420, "Standard Guide to Site Characterization for Engineering Design and Construction Purposes," provides general guidelines for minimum sample weights. These guidelines are presented in [Table 6.29](#). More specific guidance on minimum sample weight is provided in the instructions for individual test procedures.

For moisture-sensitive, fine-grained soils, samples should be retained in sealed containers, and bulk samples should be labeled, indicating information such as test pit number, depth below the ground surface, and date sampled.

TABLE 6.28 TYPICAL LABORATORY SOIL TESTS FOR VARIOUS MATERIALS⁽¹⁾

Test	ASTM Test Method	Type of Material ⁽²⁾						Use in Design
		Fine-Grained Soil	Coarse-Grained Soil	Rock	Coarse Refuse	Fine Refuse	Combined Refuse	
<u>Classification or Index Property Tests</u>								
Moisture Content	D 2216	a	a	–	a	a	a	Evaluation of feasible configuration Correlation of materials
Unit Weight	–	c	–	–	–	c	c	Selection of samples for other tests
Specific Gravity	D 854	b, c	b, c	b	b	b	b	Selection of borrow areas
Atterberg Limits	D 4318	b, c	b, c	–	–	b, c	–	Specification of construction procedures
Particle-Size Analysis	D 422, D 2217	b, c	b, c	b	b	b, c	b	Determination of filter and drainage requirements
Soil Classification	D 2487	a	a	–	–	–	–	
<u>Compaction Tests</u>								
Standard Proctor	D 698	b	–	–	b	b	b	Evaluation of sample preparation for other tests
Modified Proctor	D 1557	b	–	–	b	b	b	Specification of placement requirements
Relative Density	D 4253, D 4254	–	b	b	b	–	–	
<u>Hydraulic Conductivity</u>	D 2434, D 5084	c, d	–	–	d	c, d	c, d	Seepage analyses Determination of pore pressure for stability
<u>Consolidation</u>	D 2435, D 4186	c, d	–	–	–	c, d	–	Settlement analyses
<u>Shear Strength</u>								
Direct Shear	D 3080	c, d	d	d	d	c, d	c, d	
Triaxial compression	D 2850, D 4767	c, d	d	–	d	c, d	c, d	Stability analyses Structure foundation design
Unconfined compression	D 2166	c, d	–	–	–	–	–	
Vane Shear	D 4648	c	–	–	–	c	–	
Direct Simple Shear	D 6528	–	–	–	–	–	–	

TABLE 6.28 TYPICAL LABORATORY SOIL TESTS FOR VARIOUS MATERIALS⁽¹⁾
 (Continued)

Test	ASTM Test Method	Type of Material ⁽²⁾						Use in Design
		Fine-Grained Soil	Coarse-Grained Soil	Rock	Coarse Refuse	Fine Refuse	Combined Refuse	
<u>Rock Property and Behavior Tests</u>								
Point Load	D 5731	–	–	c	–	–	–	Design of rock slopes
Unconfined Compression	D 7012	–	–	c	–	–	–	Stability of underground mine roofs, pillars and barriers
Slake Durability	D 4644	–	–	c	–	–	–	Evaluation of rock degradation
Indirect Tensile Strength	D 3967	–	–	c	–	–	–	
<u>Miscellaneous Tests</u>								
Ash Content	D 2415	–	–	–	b	b	b	Evaluation of burning potential
Pyrite Content	D 4239, D 2492	–	–	b	b	b	b	Corrosion analyses
Leachate Water Quality	D 1068, D 858, D 516	–	–	–	b ⁽³⁾	b ⁽³⁾	b ⁽³⁾	

Note: 1. The testing program for all significant coal refuse embankments should be established by a qualified, experienced geotechnical engineer. The types and numbers of tests needed will vary depending of the purpose of the testing program and the condition being evaluated. Use of these guidelines should not be substituted for evaluation of specific site conditions by a qualified engineer. Additional discussion is provided in Section 6.5.

2. a – tests normally conducted on all samples
 b – tests normally conducted on representative disturbed samples
 c – tests normally conducted on representative undisturbed samples
 d – tests should be conducted on specially-prepared samples to simulate as-constructed behavior

3. Discussion related to conducting water quality tests as part of the geotechnical investigation is provided in Section 6.4.4.

6.5.1.2 Undisturbed Samples

Undisturbed samples are obtained from cohesive soil strata for laboratory testing to determine properties such as strength, stratification, hydraulic conductivity, density, consolidation, dynamic behavior, and other engineering characteristics. Specialized procedures are required for obtaining undisturbed samples of granular soils, thus their application at coal refuse disposal sites is limited to locations where void ratio, density and strength tests are needed for seismic design. Undisturbed samples are obtained with specialized equipment designed to minimize the disturbance to the in-situ structure and moisture content of the soils. Table 6.18 provides a summary of common methods for obtaining undisturbed soil samples. The importance of sample preservation during undisturbed sample recovery and transport is described in Section 6.4.3.5.

TABLE 6.29 GUIDELINES FOR MINIMUM SAMPLE WEIGHTS

Test and Soil Characteristics	Minimum Sample Weight
Visual classification	2 ounces to 1 pound
Soil constants and particle-size analysis of non-gravelly soil	1 to 5 pounds
Soil compaction tests and sieve analysis of gravelly soils	40 to 80 pounds
Aggregate properties	100 to 400 pounds

(ADAPTED FROM ASTM, 2008b,c)

6.5.1.3 Reconstituted Samples

Occasionally due to lack of adequate sample volume, difficulties encountered in the field in retrieving undisturbed samples, or dimensional requirements imposed by specific test methods, samples must be created or reconstituted in the laboratory for testing to establish engineering properties needed for design. The need to use reconstituted samples is more common for granular soils because undisturbed sampling of sands and gravels is difficult and costly and because the particle sizes in the coarser fraction of a sample may exceed particle-size limits in some tests. For example, the relative density of a saturated sand or of fine coal refuse can be estimated by in-situ testing, but an acceptably undisturbed sample for cyclic triaxial testing in the laboratory is difficult and costly to obtain. As a result, samples may need to be prepared in the laboratory to reasonably recreate the in-situ relative density or void ratio of the soil or sand-like refuse material. For predominantly coarse-grained soils, samples can be reconstituted by compaction in a mold. For sand-like refuse material, samples can be reconstituted by molding moist material or settling from a slurry. For clay-like fine refuse, the depositional history cannot be readily recreated in the laboratory, so reconstituted samples should not be used.

Reconstituted samples may also be necessary when the coarse particle-size fraction of a sample (usually a bulk sample) exceeds a dimensional limitation associated with the desired test. For example, ASTM D 3080, "Standard Test Method for Direct Shear Test of Soils under Consolidated Drained Conditions," prescribes that the maximum particle size not exceed 0.1 times the tested sample diameter (for circular samples) or sample width (for square samples). With this criterion, the maximum sample particle size cannot exceed 0.2 inches (corresponding approximately to a No. 4 sieve) for a 2-inch-diameter sample and 0.4 inches (corresponding approximately to a $\frac{3}{8}$ -inch sieve) for a 4-inch-square sample. For this example, if the maximum particle size exceeded 0.4 inches, the particle-size distribution for the sample used for direct shear testing would need to be adjusted to accommodate the maximum-particle-size criterion. ASTM test methods identify such gradational limitations and describe sample preparation techniques and test result evaluation methods to account for the removal of over-size particle fractions.

6.5.2 Classification and Index Property Tests

To catalog soils and coal refuse materials that will form the foundation, embankment cross section, and impoundment of a coal refuse disposal facility, samples from the field testing program should be examined and accurately classified. The system of classification used by most geotechnical engineers and government agencies is the Unified Soil Classification System (USCS) as described in ASTM D 2487, "Standard Practice for Classification of Soils for Engineering Purposes (Unified Classification System)." This classification system for engineering purposes is based on laboratory determination of particle-size distribution and Atterberg limits. ASTM D 2488, "Standard Practice for Description and Identification of Soils (Visual-Manual Procedure)," provides a companion procedure for preliminary classification of soils based on visual and manual techniques available to field and laboratory personnel.

As shown in Table 6.30, the USCS divides soils into two main classes: coarse-grained and fine-grained soils. Highly organic soils form an additional division. Coarse-grained soils are soils composed of predominantly gravel- and/or sand-sized particles (greater than 50 percent retained on a No. 200 sieve) that can be separated into eight groups based primarily on the coarseness, gradation, and percentage of fines and secondly on the plasticity of fines. Fine-grained soils are soils composed of predominantly silt- and/or clay-sized particles (greater than 50 percent passing a No. 200 sieve) that can be separated into six groups, based primarily on plasticity and secondly on coarseness, gradation, and percentage of coarse fractions, if present. Generally, the system is arranged so that any sample can be classified by visual observation and simple tests that often can be conducted in the field by the engineer or geologist supervising an exploration program. However, laboratory tests on representative samples are needed to confirm the visual classification of soil properties or to classify borderline cases. Table 6.30 provides numerical criteria used for classification based upon laboratory test results. Figure 6.32 presents the plasticity chart used to classify fine-grained soils based on the liquid limit (LL) and plasticity index (PI) of tested samples.

Table 6.8, as adapted from Sherard et al. (1963), presents an approximate correlation between the USCS classification and the engineering and design properties of soils. Although the table is not a substitute for detailed laboratory tests, it can be used to help determine which tests should be conducted and to preliminarily evaluate available embankment materials.

There are no categories in the USCS for coal refuse materials, and current practice is to classify and test them in the same manner as other soil materials. Each of the following discussions of classification tests concludes with information on coal refuse properties as compared to properties of other soils. The basis for the discussion includes published data, as cited, and project experience, although it should be recognized that substantial variation can occur due to site-specific conditions and mining and coal preparation practices.

6.5.2.1 Moisture Content

Moisture content tests are typically conducted on disturbed and undisturbed samples obtained at a site to: (1) better characterize in-situ conditions and evaluate other tests, (2) evaluate borrow material suitability through comparison of natural moisture content and the moisture content required for proper compaction, and (3) provide information for calculating the void ratio of saturated samples.

Void ratio is defined as the ratio of void space to the volume of the solid particles:

$$e = V_v / V_s \quad (6-9)$$

where:

$$\begin{aligned} V_v &= \text{volume of voids (length}^3\text{)} \\ V_s &= \text{volume of solids (length}^3\text{)} \end{aligned}$$

Properly obtained samples of fine-grained soils sealed in plastic, wax or airtight jars at the time of sampling can be accurately tested for moisture content at a later time in the laboratory. Testing of coarse-grained soils may not be accurate if water is lost by drainage during sampling. The field engineer should note whether moisture content measurements for coarse-grained soil samples may have been affected by the sampling.

As described in ASTM D 2216, "Standard Test Method for Laboratory Determination of Water (Moisture) Content of Soil and Rock by Mass," the procedure for measuring moisture content is to weigh

TABLE 6.30 SOIL CLASSIFICATION CHART (LABORATORY METHOD)

Criteria for Assigning Group Symbols and Group Names Using Laboratory Tests ⁽¹⁾			Soil Classification	
			Group Symbol	Group Name ⁽²⁾
GRAVELS ≥ 50% of coarse fraction retained on No. 4 Sieve	CLEAN GRAVELS	$C_u \geq 4$ and $1 \leq C_c \leq 3^{(5)}$	GW	Well-graded Gravel
	< 5% fines	$C_u < 4$ and/or $1 > C_c > 3^{(5)}$	GP	Poorly-graded Gravel ⁽⁶⁾
	GRAVELS WITH FINES > 12% fines ⁽³⁾	Fines classify as ML or MH	GM	Silty Gravel ^(6,7,8)
		Fines classify as CL or CH	GC	Clayey Gravel ^(6,7,8)
SANDS ≥ 50% of coarse fraction retained on No. 4 Sieve	CLEAN SANDS	$C_u \geq 6$ and $1 \leq C_c \leq 3^{(5)}$	SW	Well-graded Sand ⁽⁹⁾
	< 5% fines ⁽⁴⁾	$C_u < 6$ and $1 > C_c > 3^{(5)}$	SP	Poorly-graded Sand ⁱ
	SANDS WITH FINES > 12% fines ⁽⁴⁾	Fines classify as ML or MH	SM	Silty Sand ^(7,8,9)
		Fines classify as CL or CH	SC	Clayey Sand ^(7,8,9)
SILTS AND CLAYS LL < 50	Inorganic	PI > 7 and plots on or above "A" line ⁽¹⁰⁾	CL	Lean Clay ^(11,12,13)
		PI < 4 or plots below "A" line ⁽¹⁰⁾	ML	Silt ^(11,12,13)
	Organic	LL after oven drying < 0.75 LL before oven drying	OL	Organic Clay ^(11,12,13,14)
			OL	Organic Silt ^(11,12,13,15)
SILTS AND CLAYS LL ≥ 50	Inorganic	PI plots on or above "A" line	CH	Fat Clay ^(11,12,13)
		PI plots below "A" line	MH	Elastic Silt ^(11,12,13)
	Organic	LL after oven drying < 0.75 LL before oven drying	OH	Organic Clay ^(11,12,13,16)
			OH	Organic Silt ^(11,12,13,17)
Highly fibrous organic soils	Primarily organic matter, dark in color, with organic odor		PT	Peat and Muskeg

- Note: 1. Based on the material passing the 3-in (75-mm) sieve.
2. If field sample contained cobbles or boulders, or both, add "with cobbles" or "with boulders" to group name.
3. $C_u = D_{60}/D_{10}$ = uniformity coefficient (UC);
 $C_c = (D_{30})^2 / (D_{60} \times D_{10})$ = coefficient of curvature
4. If soil contains ≥ 15% sand, add "with sand" to group name.
5. Gravels with 5 to 12% fines require dual symbols:
GW-GM – well-graded gravel with silt
GW-GC – well-graded gravel with clay
GP-GM – poorly-graded gravel with silt
GP-GC – poorly-graded gravel with clay

TABLE 6.30 SOIL CLASSIFICATION CHART (LABORATORY METHOD)
(Continued)

- Note
6. If fines classify as CL-ML, use dual symbol GC-GM or SC-SM.
 7. If fines are organic, add "with organic fines" to group name.
 8. If soil contains $\geq 15\%$ gravel, add "with gravel" to group name.
 9. Sands with 5 to 12% fines require dual symbols:
 - SW-SM – well-graded sand with silt
 - SW-SC – well-graded sand with clay
 - SP-SM – poorly-graded sand with silt
 - SP-SC – poorly-graded sand with clay
 10. If Atterberg limits plot in the orange area in Figure 6.32, soil is a CL-ML (silty clay).
 11. If soil contains 15 to 29% plus No. 200 sieve, add "with sand" or "with gravel," whichever is predominant.
 12. If soil contains $\geq 30\%$ plus No. 200 sieve, predominantly sand, add "sand" to group name.
 13. If soil contains $\geq 30\%$ plus No. 200 sieve, predominantly gravel, add "gravelly" to group name.
 14. $PI \geq 4$ and plots on or above "A" line.
 15. $PI < 4$ or plots below "A" line.
 16. PI plots on or above "A" line.
 17. PI plots below "A" line.

(ADAPTED FROM ASTM, 2008b,c)

a wet sample, dry it in a constant-temperature oven at 105° C until the weight is constant (approximately 24 hours for small samples of fine-grained soils), and then weigh the dry sample. In soil mechanics practice, the moisture content is defined as the ratio of the weight of water (wet weight minus dry weight) to the dry weight. This is sometimes referred to as the dry-weight-basis moisture content. In other disciplines, moisture content may be defined on a wet-weight basis, i.e., moisture content is defined as the ratio of the weight of water to the wet weight of soil.

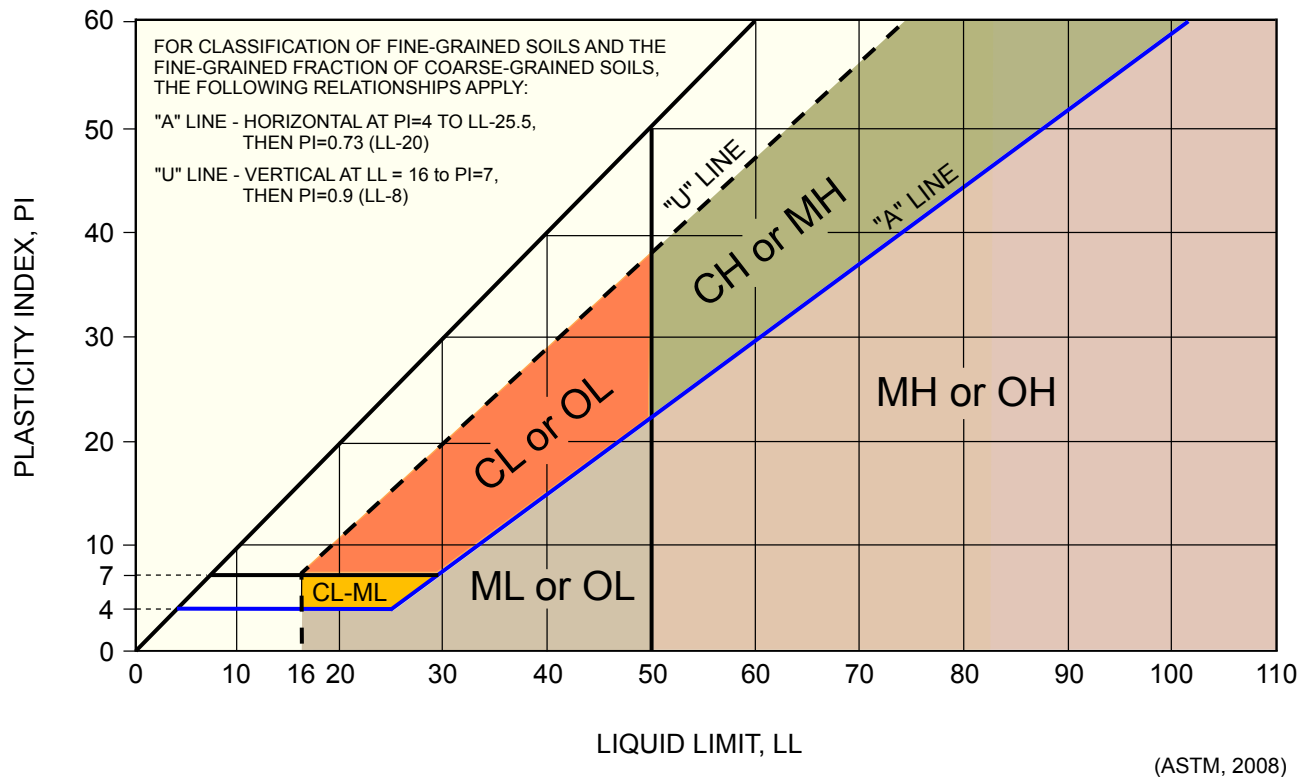

FIGURE 6.32 PLASTICITY CHART

If a soil sample contains a significant amount of organic material, this method of measuring moisture content is not always satisfactory, because heating the sample to 105° C may drive off some of the organic material in addition to the water. Alternatively, ASTM D 2216 permits oven drying at 60° C for the moisture content of organic soils and organic materials. Most coal refuse is not significantly affected by oven drying at 105° C, although this may need to be considered when working with lower grade coals such as lignite.

6.5.2.2 Specific Gravity

The specific gravity of a soil is the ratio of the weight of a given volume of soil solid particles to the weight of an equal volume of distilled water at 4° C. As used in geotechnical engineering, the term specific gravity refers to the average specific gravity of the individual soil particles in a sample rather than bulk specific gravity. Specific gravity is determined in the laboratory in accordance with ASTM D 854, "Standard Test Methods for Specific Gravity of Soil Solids by Water Pycnometer." The test is performed by weighing a calibrated bottle containing soil particles suspended in distilled water and comparing this to the weight of the same bottle containing an equal volume of distilled water only. Specific gravity is used to determine relationships between soil weight and soil volume. Specific gravity is used for: (1) computing the void ratio of a soil, (2) hydrometer analyses, and (3) predicting the unit weight of a soil. Occasionally, the specific gravity may be useful in soil mineral classifications (e.g., iron minerals have a higher specific gravity than silica).

Soils typically have a specific gravity ranging from 2.4 to 2.8. For many design purposes specific gravity can be estimated without testing. For coal refuse facilities, specific gravity is an important design parameter because coal refuse often contains a significant amount of materials with specific gravity in the range of 1.3 to 1.6. As a result, coarse coal refuse can have a specific gravity ranging from as low as 1.5 to as high as 2.8. The most common range is between 1.9 and 2.4. Similarly, specific gravity measured for fine coal refuse typically ranges from 1.4 to 2.3. Published data on specific gravity and unit weight of coarse and fine coal refuse from sites in the northern Appalachian region illustrating some of the variability in these parameters is presented in Tables 6.31 and 6.32, respectively, as compiled by Hegazy et al. (2004). The database for these summaries from Hegazy et al. (2004) was developed from geotechnical investigations of existing coal refuse disposal sites in western Pennsylvania and England. In-situ samples were collected from the sites using both disturbed methods (bucket samples from test pits and fine coal refuse deltas and split-barrel samples from boreholes) and undisturbed sampling methods (Shelby- and Dennison-tube samples).

The coefficient of variability (COV) is the ratio of the standard deviation of a set of data divided by the mean. Typically, values of COV below 10 percent are thought to be low, between 10 and 30 percent moderate, and above 30 percent high. Values of total unit weight γ_T , dry unit weight γ_D , and specific gravity G_s for coarse and fine coal refuse are provided in Tables 6.31 and 6.32. For coarse coal refuse, Table 6.31 indicates low variability for γ_T and γ_D and moderate variability for G_s . For fine coal

TABLE 6.31 IN-PLACE UNIT WEIGHT AND SPECIFIC GRAVITY OF COARSE COAL REFUSE

Property	Dimension	Average	Standard Deviation	Coefficient of Variation
γ_T	lb/ft ³	124	5.8	0.048
γ_D	lb/ft ³	115	5.5	0.047
G_s	Dimensionless	2.02	0.31	0.154

(ADAPTED FROM HEGAZY ET AL., 2004)

refuse, Table 6.32 indicates low variability for γ_T and moderate variability for γ_D and G_s . Figure 6.33 shows the effect of carbon content on the specific gravity of coal refuse materials.

Designers should recognize that values of specific gravity and unit weight for coal refuse are lower than for commonly encountered soils. The lower specific gravity of coal refuse results in lower densities, higher moisture contents at a given void ratio, and the potential for reduced stability with respect to seepage forces. These characteristics are discussed further in Section 6.6.4.

6.5.2.3 Atterberg Limits

The Atterberg Limits define the boundaries between four states of consistency (hardness or softness) of fine-grained soils. In order of decreasing moisture content, these states are: liquid, plastic, semi-solid and solid. The boundaries or limits between these states are:

- Liquid limit (*LL*) – boundary between the liquid and plastic states
- Plastic limit (*PL*) – boundary between the plastic and semi-solid states
- Shrinkage limit (*SL*) – boundary between the semi-solid and solid states

The plasticity index (*PI*) is defined as *LL* minus *PL*. The liquid and plastic limits and plasticity index are determined in accordance with ASTM D 4318, “Standard Test Methods for Liquid Limit, Plastic Limit, and Plasticity Index of Soils.” The shrinkage limit is determined in accordance with D 4943, “Standard Test Method for Shrinkage Factors of Soils by the Wax Method.”

TABLE 6.32 UNIT WEIGHT AND SPECIFIC GRAVITY FOR FINE COAL REFUSE

Property	Dimension	Average	Standard Deviation	Coefficient of Variation
γ_T	lb/ft ³	86	7.7	0.096
γ_D	lb/ft ³	62	9.1	0.162
G_s	Dimensionless	1.52	0.25	0.165

(ADAPTED FROM HEGAZY ET AL., 2004)

The liquid limit is the moisture content at which the soil sample flows and closes a standard width groove when the sample is jarred in a specified way. For practical purposes, it is the moisture content at which the soil has essentially no shear strength (the soil becomes liquid). The test for the *LL* is conducted using a standard liquid-limit device and grooving tool. The plastic limit is the moisture content at which the soil begins to crumble when rolled by hand into 1/8-inch-diameter threads. The shrinkage limit (*SL*) is the moisture content sufficient to fill the pores of the soil at the minimum volume it will attain by drying. Other useful parameters from these tests are the plasticity index (*PI*) and the liquidity index (*LI*). The plasticity index is an indicator of soil plasticity, and the *LI*, which equals $(w - PL)/PI$, is an indicator of stress history and soil sensitivity. The liquidity index is approximately 1 for normally-consolidated soils and zero for over-consolidated soils. An *LI* greater than 1 indicates high sensitivity.

Many properties of fine-grained clays and silts can be correlated to the Atterberg limits, and the plasticity chart shown in Figure 6.32 can be useful in interpreting the correlation. Procedures for using the plasticity chart for various soil types are discussed by Terzaghi et al. (1996).

Caution and considerable judgment should be used when applying the plasticity chart to coal refuse, because the chart is based on the behavior of natural, fine-grained soils. Tests conducted on only the

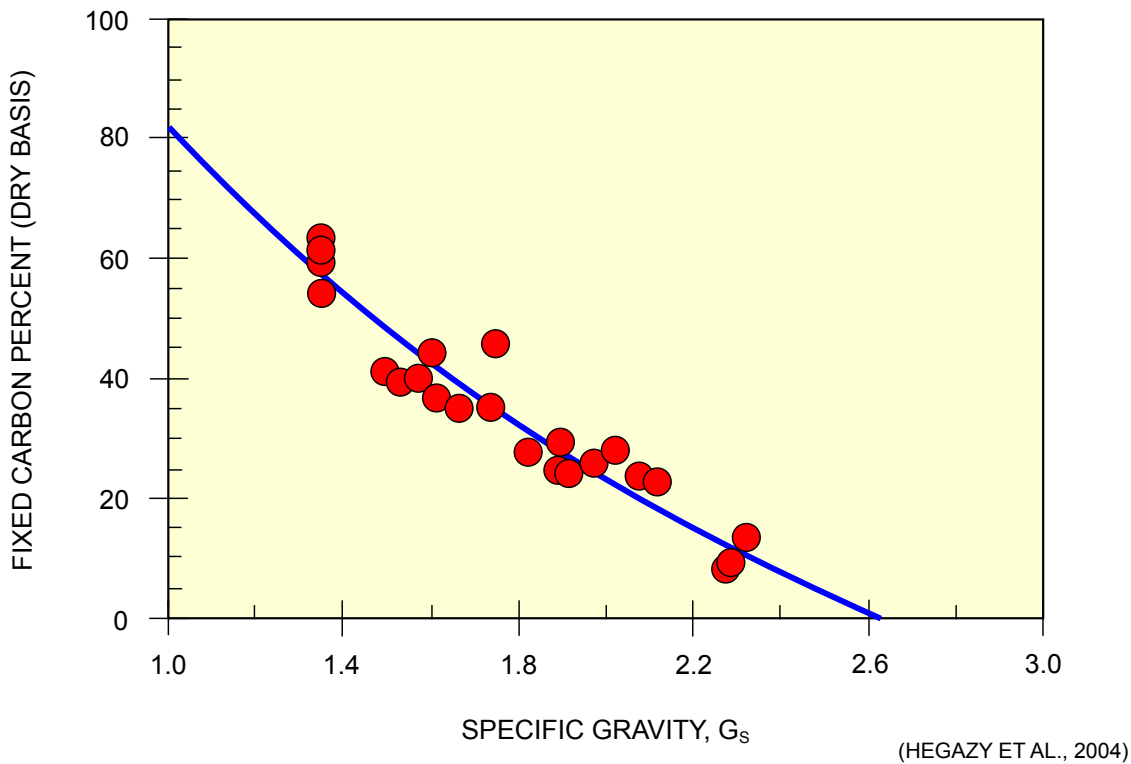

FIGURE 6.33 EFFECT OF CARBON CONTENT ON SPECIFIC GRAVITY OF COAL REFUSE MATERIAL

finer portion of coarse refuse have obtained LL 's in the range of 25 to 35 percent and PI 's typically below 12 percent. Table 6.4 cites published data characterizing the properties of fine coal refuse. Tests conducted on fine refuse samples from impoundments show LL 's in the range of 20 to 40 percent and PI 's generally below 15 percent, although higher PI 's have been reported. Factors affecting plasticity are discussed in Section 6.2.3.2. A summary of statistical properties related to Atterberg limits for fine coal refuse from northern Appalachian sites is provided in Table 6.33. Other data suggest that the plasticity of fine refuse from an impoundment increases with distance from the slurry discharge point, as the content of clay-size refuse particles increases.

6.5.2.4 Particle-size Distribution

The particle-size distribution of a coarse-grained soil is an important factor in its engineering behavior. The particle-size distribution of a coarse-grained soil can be used to classify the soil, to estimate hydraulic conductivity and to provide a qualitative indication of soil strength and deformation characteristics. For fine-grained soils, plasticity and moisture content are better indices of soil behavior than particle-size distribution. For both fine and coarse material, the particle-size distribution is needed for checking filter criteria requirements as part of prevention of piping of fines into coarser filter and drainage zones. Figure 6.34 shows typical gradation curves for several types of materials including coarse and fine coal refuse. Of particular note is the correlation between types of soil (clay, silt, sand and gravel) and sieve sizes and particle diameters.

For comparative purposes between soil types and for certain design applications, the uniformity of a soil can be expressed by the uniformity coefficient, which is the ratio of D_{60} to D_{10} , where D_{60} is the particle diameter at which 60 percent of the soil weight is finer and D_{10} is the particle diameter at which 10 percent of the soil weight is finer. Sand and gravel soils having uniformity coefficients less than 6 and 4, respectively, are considered to be "uniform." For example, the uniformity coefficients of

TABLE 6.33 STATISTICAL PROPERTIES FOR ATTERBERG LIMITS AND MOISTURE CONTENTS OF FINE COAL REFUSE AT NORTHERN APPALACHIAN SITES

Property	Average (%)	Standard Deviation	Coefficient of Variation
<i>LL</i>	31.2	5.2	0.17
<i>PL</i>	20.1	3.4	0.17
<i>PI</i>	11.2	3.1	0.28
<i>w</i>	33.0	11.5	0.35

(HEGAZY ET AL., 2004)

the two sandy soils shown in Figure 6.34 are about 6.1 and 1.4. These soils are termed “well-graded sand” and “uniform sand,” respectively.

As described in ASTM D 422, “Standard Test Method for Particle-Size Analysis of Soils,” the particle-size distribution of the portion of a soil sample coarser than a No. 200 sieve (0.074-mm-square openings) is generally determined by sieve analysis. This procedure consists of shaking a dry soil sample or washing a wet soil sample through a stack of wire screens of decreasing opening size. The diameter of an individual soil particle is defined as the minimum side dimension of a square hole through which the soil particle will pass.

The particle-size distribution of the portion of a sample finer than a No. 200 sieve can be measured with a hydrometer test as described in ASTM D 422. In this test, a sample of soil is vigorously mixed with water and a deflocculating agent to form a suspension. The suspension is then allowed to sit

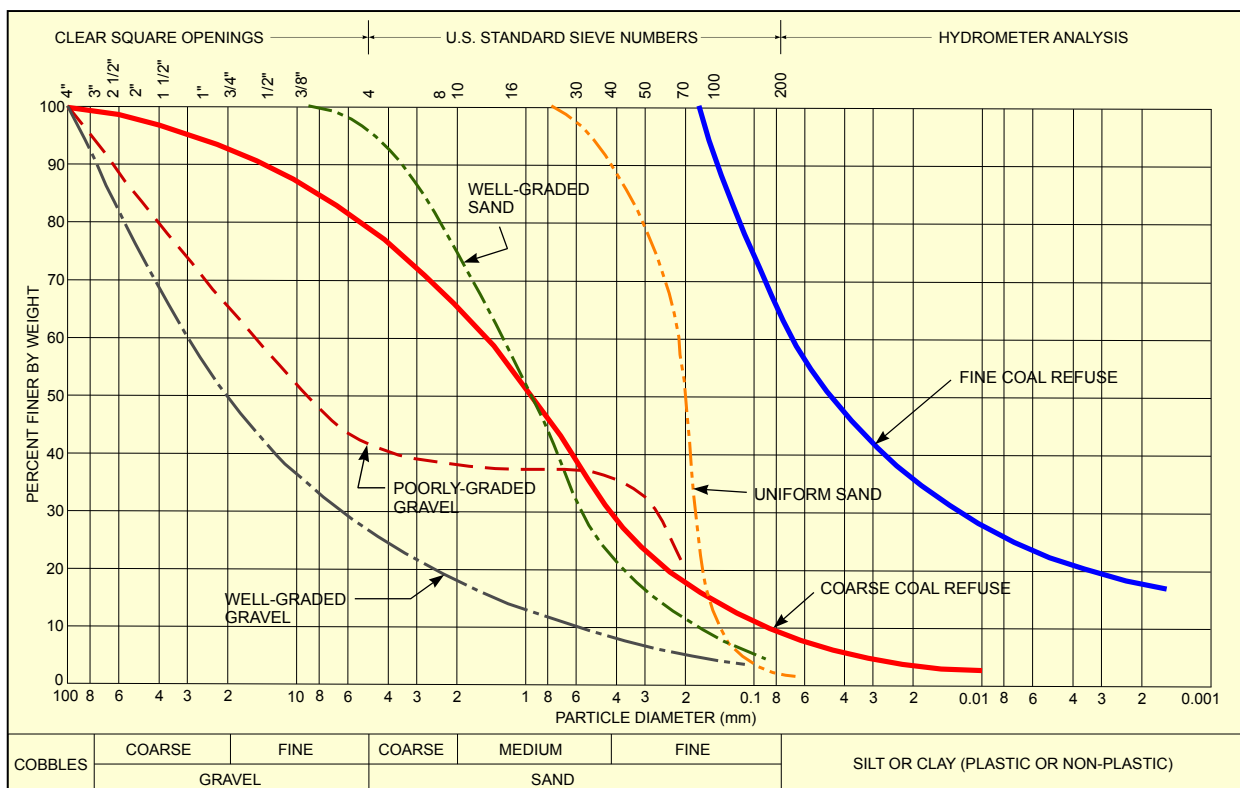

FIGURE 6.34 PARTICLE SIZE DISTRIBUTION

undisturbed in a 1000-ml glass cylinder to permit settlement of the suspended soil particles. Periodically, the change in the specific gravity of the suspension is measured with a calibrated hydrometer, allowing the approximate distribution of particle sizes to be calculated. The specific gravity of the suspension changes with time because the larger particles settle faster than smaller particles of the same specific gravity. The test result is only approximate because the calculation is based upon the assumption that the particles are spherical, of equal specific gravity, and do not interfere with each other during settlement. In actual tests, the particles are not spherical, there are variations in specific gravity, and considerable interference between particles likely occurs during settlement. Because the distributions determined by the hydrometer test are primarily used for comparative purposes, the accuracy of the test is generally not of major concern.

The effect of differences in specific gravity of various particles in the hydrometer test is greater for coal refuse than for other soils, because coal refuse consists of coal with specific gravity as low as 1.3 and rock fragments with specific gravity as high as 2.8. For most analyses of coal refuse, it is appropriate to consider the average specific gravity of the entire sample. However, it should be understood that the variation in specific gravity of coal refuse particles adds greater than normal inaccuracy to the portion of the gradation curve determined by the hydrometer method.

Coarse coal refuse delivered to disposal facilities typically has the grain-size distribution of a well-graded silty sand and gravel. Coal preparation usually limits the upper size to about 5 inches, although this size has more characteristically been less than 3 inches. Uniformity coefficients for coarse refuse range from about 20 to several hundred. Because many coal refuse particles are extremely friable and highly susceptible to both chemical and mechanical deterioration, the particle-size distribution changes during preparation, transportation and placement at the disposal facility. As delivered to the point of disposal, coarse refuse typically contains between 5 and 30 percent of particles finer than the No. 200 sieve (0.075 mm). The clay-size fraction (finer than 0.002 mm) is usually very small and often less than 2 percent. Sampling programs should be designed to evaluate the potential for particle degradation through collection of both as-delivered samples and after-placement samples.

Particle-size degradation occurs at the surface of a coarse refuse embankment or disposal facility, due to both chemical and mechanical deterioration. This behavior is described in Andrews et al. (1980) where the environmental effects of slaking of surface mine spoils in the eastern and central U.S. were evaluated. The study showed that degradation of surface mine spoil occurred over periods of years depending on the rock type(s) found in the spoil and their depth of burial. Field examination showed that degradation was more predominant with finer-grained, rock-type spoils (e.g., shales, mudstones and claystones) and was most prevalent in the upper 5 to 10 feet depending on the amount of compaction (if any) during spoil placement. For embankments constructed using coarse refuse, particle-size degradation is also affected by hauling equipment and mechanical compaction that occurs as the material is placed.

Fine coal refuse delivered to disposal facilities from preparation plants is typically a slightly clayey, sandy silt. Generally, 50 to 80 percent of the material will pass the No. 200 sieve, most of which is silt-size. Fine refuse segregates after being deposited, with the larger and heavier particles settling out of suspension near the discharge point. Farther from the discharge point, the settled refuse is predominantly finer-grained, and samples containing nearly 50 percent clay-size particles have been reported. A summary of statistical properties related to particle-size distribution for fine coal refuse samples from sites in northern Appalachia is provided in [Table 6.34](#).

6.5.2.5 Chemical Characterization

Some soil and rock materials encountered at refuse disposal sites and the refuse being placed can have adverse chemical characteristics that may lead to undesirable environmental conditions or deteriora-

TABLE 6.34 PARTICLE-SIZE DISTRIBUTION FOR FINE COAL REFUSE

Particle Size or Percent Passing	Dimension	Average	Standard Deviation	Coefficient of Variation
D_{10}	mm	0.010	0.015	1.50
D_{30}	mm	0.037	0.055	1.49
D_{50}	mm	0.127	0.128	1.01
D_{60}	mm	0.196	0.209	1.07
Passing No. 200 (0.075-mm) sieve	%	57.7	25.0	0.43

(HEGAZY ET AL., 2004)

tion of construction materials. Therefore, the chemical characteristics of these materials (e.g., corrosivity, organic content, ash content, pyrite content, and leachate water quality) should be determined. When deleterious conditions are encountered, appropriate amendment or containment/protection requirements should be implemented. Table 6.35 lists laboratory test methods that can be used for chemical characterization of soil, rock and refuse materials.

6.5.3 Compaction and Density Tests

Any soil placed as part of a structural fill, including coal refuse in embankments, is normally compacted to increase density and shear strength and to decrease compressibility and hydraulic conductivity. This makes relatively steep slopes possible, reduces seepage from impoundments, and reduces the potential for spontaneous combustion by reducing the flow of air and water into the embankment. In the field, compaction is accomplished with various types of rollers, including sheepfoot, static and vibrating steel drum, and rubber-tired. The type of roller that is most appropriate depends upon the material being compacted, as discussed in Section 11.4.3.

6.5.3.1 Fine-grained Soils and Coal Refuse

Standard laboratory test procedures to control and evaluate the degree of compaction that can be achieved in the field during placement have been established. The test most commonly used for fine-grained soils and coal refuse utilizes impact compaction. The test procedure entails placing soil or refuse in several layers in a standard mold and compacting each layer by dropping a hammer of specified weight a specified distance for a specified number of times per layer.

The two standardized impact compaction tests are the standard Proctor and the modified Proctor tests. The standard Proctor compaction test was developed in the 1930s and was designed to approximate the compactive energy applied by field compaction equipment then available. As field equipment became larger and more efficient, the modified proctor compaction test was developed to approximate the greater compactive energy of the newer equipment. The test procedures for the standard and modified Proctor compaction tests are described in ASTM D 698, "Standard Test Methods for Laboratory Compaction Characteristics of Soil Using Standard Effort (12,400 ft-lbf/ft³ (600 kN-mm³))" and ASTM D 1557, "Standard Test Methods for Laboratory Compaction Characteristics of Soil Using Modified Effort (56,000 ft-lbf/ft³ (2,700 kN-mm³)), respectively.

These test methods are suitable for soils and coal refuse that have 30 percent or less retained on the 3/4-inch sieve and that have more than 15 percent by dry weight passing a No. 200 sieve. If more than 30 percent is retained on a 3/4-inch sieve for either test, the unit weight and moisture content should be corrected in accordance with ASTM D 4718, "Standard Practice for Correction of Unit Weight and Water

TABLE 6.35 TEST METHODS FOR CHEMICAL CHARACTERIZATION OF SOIL, ROCK AND REFUSE MATERIALS

Item	Description	ASTM Test Method
Corrosivity	Standard Test Method for pH of Soils	D 4972
	Standard Test Method for pH of Soil for Use in Corrosion Testing	G 51
	Standard Test Method for Sulfate Ion in Brackish Water	D 4130
	Standard Test Method for Field Measurement of Soil Resistivity Using the Wenner Four-Electrode Method	G 57
	Standard Test Methods for Chloride Ion in Water	D 512
Organic Content	Standard Test Methods for Moisture, Ash, and Organic Matter of Peat and Other Organic Soils	D 2974
Ash Content	Standard Test Method for Ash in Coal Tar and Pitch	D 2415
Pyrite Content	Standard Test Method for Forms of Sulfur in Coal	D 2492
Leachate Water Quality ⁽¹⁾	Standard Test Method for Leaching Solid Material in a Column Apparatus	D 4874
	Standard Test Method for Shake Extraction of Mining Waste by the Synthetic Precipitation Leaching Procedure	D 6234

Note: 1. State regulatory agencies may require specific test procedures. Other standard test method references include EPA Method 1312, "Synthetic Precipitation Leaching Procedure (SPLP)" and EPA Method 1320, "Multiple Extraction Procedure (MEP)."

Content for Soils Containing Oversize Particles." Alternatively, a 12-inch-diameter compaction mold using standard Proctor compactive effort can be employed using the U.S. Army Corps of Engineers procedure, "Compaction Test for Earth-Rock Mixtures," described in Section 11.5.1 (USACE, 1986). If less than 15 percent by dry weight passes the No. 200 sieve, the density of the soil may not be affected by changes in moisture, and the guidelines presented in Section 6.5.3.2 for coarse-grained soils may be applicable. Coarse coal refuse may contain less than 15 percent by dry weight passing a No. 200 sieve, but it generally does respond to changes in moisture content when compacted. Accordingly, in practice, the standard Proctor test is typically used to evaluate the compaction and density of coarse refuse.

Normally, a series of compaction tests is performed on several soil samples prepared at varying moisture contents. From the test results plotted as shown in Figure 6.35, the maximum density attainable and the moisture content at which the maximum density is attained (the optimum moisture content), can be determined. The greater compactive energy of the modified Proctor compaction test produces higher maximum densities at lower optimum moisture contents than the standard Proctor compaction test. The 100-percent-saturation (or zero-air-voids) curve to the right of the compaction curves in Figure 6.35 can be determined using the relationship:

$$\gamma_d = \gamma_w G_s / (1 + w G_s) \quad (6-10)$$

where:

γ_d = dry density of soil (force/length³)

γ_w = unit weight of water (force/length³)

G_s = specific gravity of solids (dimensionless)

w = moisture content expressed as a decimal value (dimensionless)

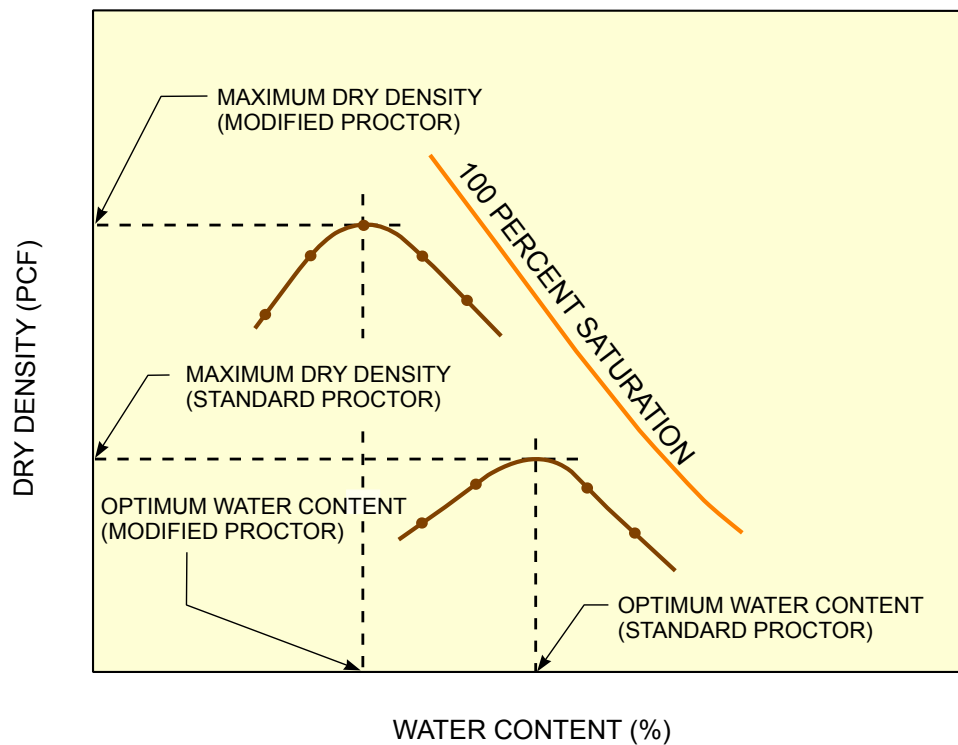

FIGURE 6.35 TYPICAL MOISTURE-DENSITY RELATIONSHIPS FOR DYNAMIC COMPACTION

Equation 6-10 provides a check on the compaction test results to confirm that no compaction test result plots to the right of the 100-percent-saturation curve and that the shape of the dry density-moisture relationship wet of optimum moisture content generally parallels the 100-percent-saturation curve. Additionally, Equation 6-10 demonstrates the need to know the specific gravity of a material when determining compaction and density.

Specifications for construction of compacted fills usually require that the density attained in the field be equal or greater than a certain percentage of the maximum density attained in the laboratory compaction tests (for structural embankment zones, normally 95 percent of the maximum density at the optimum moisture content from the standard Proctor test). To help achieve good density control, specifications also usually require the fill to be placed at a moisture content near the optimum moisture content (normally in the range from 2 percent below optimum to 3 percent above optimum).

D'Appolonia (1973) reported a measured in-place dry unit weight for uncompacted coarse refuse of 80 to 110 pounds per cubic foot (pcf), with a median value of 94 pcf based upon data from 200 tests. For compaction testing performed at mine sites in northern Appalachia, Hegazy et al. (2004) reported a median dry density for compacted coarse refuse of 115 pcf. While these results demonstrate dry densities encountered in some specific situations, there can be considerable variation depending upon geographic location and mining and coal processing activities.

Because of the degradation of coarse coal refuse due to equipment traffic during placement and weathering after placement, the percentage of fines in "aged" coarse coal refuse will likely be greater than in fresh or recently placed coarse coal refuse. Saxena et al. (1984) report that particle breakdown due to a combination of weathering and compaction produces better graded materials with higher density and strength and lower compressibility and hydraulic conductivity. Hegazy et al. (2004) presented the results of sieve analyses performed for fresh coarse coal refuse samples and repeated after compaction to determine the effect of compaction on the fines content (i.e., the percent passing the No. 200 sieve). For the tests plotted in Figure 6.36, the average increase of fines due to compaction was approximately 4 percent.

In applications sensitive to fines content, breakdown due to weathering and compaction can be evaluated through slake durability testing of fresh and weathered compacted samples (Section 6.5.9.4).

Specifications for clay core materials designed to restrict seepage through an embankment are normally based upon Proctor test results but these specifications often require that the material to be placed slightly wet of optimum. This results in lower strengths, but eliminates the potential for brittle soil behavior. The resulting core should be sufficiently flexible to allow for small amounts of differential movement without the development of cracks that would allow the passage of large volumes of water and cause piping. Sherard et al. (1963), Sherard (1973), and Lo (1990) report a number of dam failures caused by cracking, and they discuss the related importance of compaction specifications and control.

Slurry-placed fine coal refuse typically has a very low in-situ density because of low specific gravity and moisture contents near the liquid limit. Dry densities near 50 pcf have been reported. Coarser or dryer portions of the fine refuse may have dry densities of 70 pcf or higher.

6.5.3.2 Coarse-Grained Soils and Coal Refuse

Relative density is the dry density of a soil in relation to the minimum and maximum dry densities that can be achieved by specific laboratory procedures. The relative density test is applicable to free-draining, cohesionless soils with low fines content (i.e., less than 15 percent non-plastic fines passing the No. 200 sieve) that do not have a well-defined moisture-density relationship. The maximum dry density is determined in accordance with ASTM 4253, "Standard Test Methods for Maximum Index Density and Unit Weight of Soils Using a Vibratory Table," and the minimum dry density and rela-

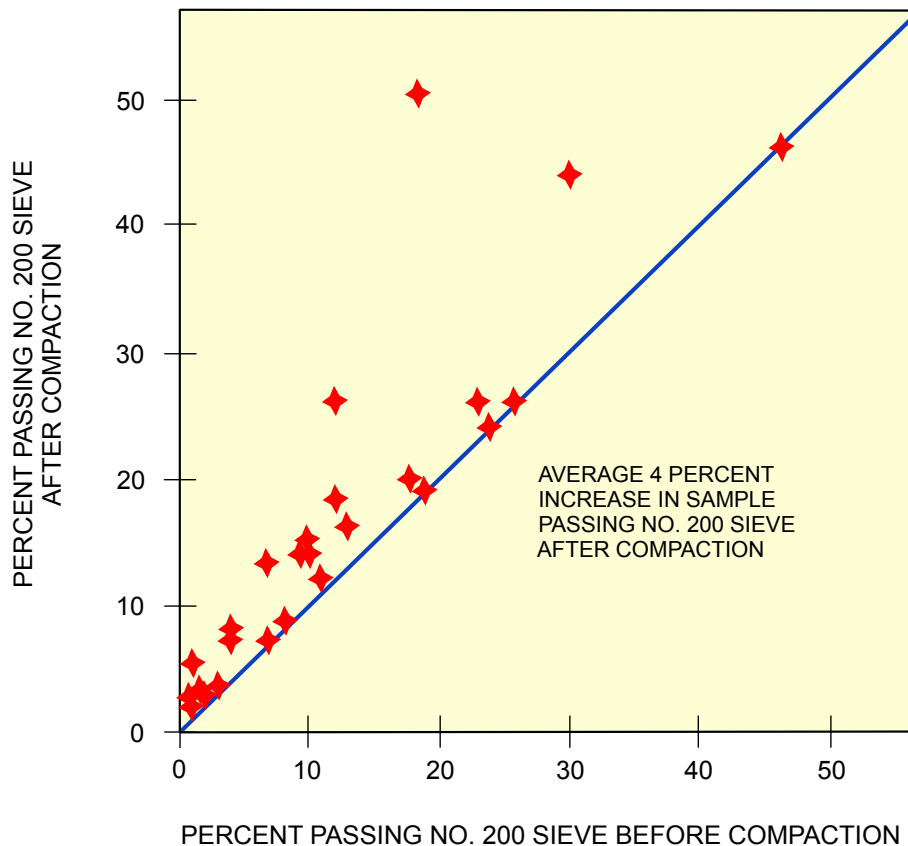

(HEGAZY ET AL., 2004)

FIGURE 6.36 PARTICLE-SIZE DISTRIBUTION OF COARSE COAL REFUSE AFTER COMPACTION

tive density are determined in accordance with ASTM 4254, "Standard Test Methods for Minimum Index Density and Unit Weight of Soils and Calculation of Relative Density."

For coal refuse embankments, the relative density test is normally applicable to materials used for granular drainage and filter zones that require compaction. Relative density tests are also conducted for evaluating the capability of a saturated, coarse-grained soil to resist seismic loadings. Seismic issues are discussed in Chapter 7.

The minimum density (zero percent relative density) in accordance with ASTM 4254 is obtained by placing dried soil as loosely as possible in a mold of known volume. The preferred method for placing soil in the mold requires using a pouring device that limits the height of free fall to no more than ½ inch. The weight of the known volume of soil is then measured and used in the determination of the minimum test dry density. The minimum density is the weight of soil divided by the volume of the mold.

The maximum dry density (100 percent relative density) in accordance with ASTM 4253 can be obtained using either dry soil (method A) or wet soil (method B). The soil is densified using either an electromagnetic, vertically vibrating table or an eccentric or cam-driven, vertically vibrating table. If method A is used, dry soil is placed in a mold using a scoop or funnel, a surcharge base plate is placed atop the level soil surface, the filled mold with surcharge weight is attached to the vibrating table, and the table is vibrated for 8 to 12 minutes depending on the frequency of vibration.

If method B is used, the mold is attached to the vibrating table, the table is turned on, and wet soil is placed in the mold over a 5- to 6-minute period during which care is taken to avoid excessive vibration that causes the soil to boil excessively. The table is then turned off, a surcharge is placed atop the soil, and the table is vibrated for 8 to 12 minutes as for Method A. After the table is turned off (both methods), the surcharge is removed and the height of the sample in the mold is measured. The material in the mold is then weighed. If the sample is wet, it is oven dried and weighed again after drying. The weight of the known volume of dried soil is used to determine the maximum dry density. The difference between the wet and dry weights can be used to determine the moisture content of the material tested.

The relative density is calculated by the relationship:

$$D_r = \frac{\gamma_{d_{max}} (\gamma_d - \gamma_{d_{min}})}{\gamma_d (\gamma_{d_{max}} - \gamma_{d_{min}})} \times 100 \quad (6-11)$$

where:

- D_r = relative density (dimensionless)
- $\gamma_{d_{max}}$ = maximum dry density (force/length³)
- $\gamma_{d_{min}}$ = minimum dry density (force/length³)
- γ_d = measured dry density of the sample (laboratory or in situ) (force/length³)

The relative density D_r is used as a basis to confirm whether placement of coarse-grained soils in the field meets the minimum specified compaction criteria. The minimum acceptable relative density for coarse-grained soils typically ranges between about 70 to 85 percent depending upon performance requirements.

6.5.4 Hydraulic Conductivity Tests

The hydraulic conductivity (or permeability) of a soil is a measure of the rate at which water will flow through a soil under a particular pressure (or head). It is represented by the coefficient of hydraulic

conductivity k , which is normally expressed in units of distance per time. Hydraulic conductivity is essentially the volume of flow per unit time per unit of cross-sectional area for a unit pressure gradient. While laboratory measurement of hydraulic conductivity can be valuable in developing design criteria, field tests are generally more representative of in-situ materials if site conditions and access allow performance of the tests.

Hydraulic conductivity is measured in the laboratory by percolating water through a soil sample of known cross-sectional area and length. The constant head hydraulic conductivity test is conducted for coarse-grained soils in accordance with ASTM D 2434, "Standard Test Method for Permeability of Granular Soils (Constant Head)." This test method is most suitable for granular soils with a hydraulic conductivity greater than 10^{-4} cm/sec that might be used for drains or filter media and that do not have more than 10 percent passing a No. 200 sieve. Soils tested using this procedure are typically compacted in a permeameter to a density comparable to the relative density used for field placement.

For soils that have a hydraulic conductivity less than about 10^{-4} cm/sec, laboratory hydraulic conductivity tests should be conducted in accordance with ASTM D 5084, "Standard Test Methods for Measurement of Hydraulic Conductivity of Saturated Porous Materials Using a Flexible Wall Permeameter." This standard permits hydraulic conductivity testing by either the constant- or falling-head methods and is suitable for soils with hydraulic conductivities not less than about 10^{-9} cm/sec. Thus, the method and equipment are suitable for testing a wide range of soils. The test specimen is sealed within a flexible membrane and enclosed within a pressure cell similar to that used for triaxial testing (Section 6.5.7.4). This setup permits back pressuring to saturate the test sample and application of high hydraulic pressures (gradients) needed for testing low hydraulic conductivity soils and fine coal refuse within a reasonable time frame of several days to a few weeks.

Table 6.8 shows the probable range of hydraulic conductivity for various USCS soil classification groups. For coal refuse, hydraulic conductivity data are less well documented. Based upon a very limited number of field tests and observations, hydraulic conductivity values for coarse coal refuse range from 10^{-6} to 10^{-2} cm/sec (about 1.0 to 10,000 ft/year). Hegazy et al. (2004) report the results of falling head and rising head slug tests that were performed to estimate the hydraulic conductivity of the coarse refuse at coal refuse disposal facilities in western Pennsylvania. The average horizontal hydraulic conductivity k_h was 3×10^{-5} cm/sec (about 30 ft/year), and the standard deviation and coefficient of variation were 2.7×10^{-5} and 0.9, respectively. Density is inversely related to hydraulic conductivity; thus equipment trafficking across the refuse surface and weathering due to exposure following placement tend to increase the density and lower the hydraulic conductivity. These environmental and construction processes can result in a vertical hydraulic conductivity on the order of 10 times less than the horizontal hydraulic conductivity, as discussed in Section 6.6.2.1. For impounding coal refuse disposal facilities, it is important to be aware of the effects of density and grain-size distribution on the hydraulic conductivity of the refuse materials.

As with coarse refuse, the hydraulic conductivity of fine coal refuse varies greatly and is difficult to predict. Typical values based on the results of piezocone dissipation tests performed at northern Appalachian sites are presented in Table 6.36. The range of estimated k_h indicates that fine coal refuse behaves similarly to very fine sands, silts and mixtures of sand, silt and clay. Some designers have reported the presence of moderate plasticity clay with very low vertical hydraulic conductivity at refuse disposal sites. In general, conservative assumptions should be made relative to the hydraulic conductivity of coal refuse, with consideration of field test data when available. Generally, conservative values are assumed based upon judgment and hydraulic conductivity values from the high end of the range determined from available test data, material classification and representative anisotropy values, resulting in either higher (more conservative) phreatic levels or seepage rates.

TABLE 6.36 ESTIMATED HORIZONTAL HYDRAULIC CONDUCTIVITY OF FINE COAL REFUSE BASED ON PIEZOCONE DISSIPATION TESTS

Test	Depth (m)	t_{50} (seconds)	c_h (cm ² /s)	k_h (cm/s)
PCPT1	7.9	800	15×10^{-3}	1.21×10^{-5}
PCPT1	19.2	30,000	0.4×10^{-3}	0.03×10^{-5}
PCPT1	22.9	40	301×10^{-3}	24.3×10^{-5}
PCPT3	13.3	128	94×10^{-3}	7.59×10^{-5}
PCPT4	21.9	300	40×10^{-3}	3.24×10^{-5}

Note: Pool level was approximately 3 m below the ground surface.

(HEGAZY ET AL., 2004)

6.5.5 Geosynthetic Materials Tests

Geosynthetic materials are polymeric sheet materials used with soil, rock, or other geotechnically-related material as an integral part of a civil engineering project, structure, or system. Geotextiles, geomembranes and geosynthetic clay liners (GCLs) are types of geosynthetic materials that may be used in the design and construction of a coal refuse disposal facility to convey or limit seepage or to act as a filter medium.

A geotextile is a permeable geosynthetic made of textile materials. At refuse disposal facilities, geotextiles are used as filters in drainage applications, as well as for material separation applications such as beneath spillway linings and haul roads.

Geomembranes are continuous polymeric sheets with very low hydraulic conductivity (typically less than 10^{-12} cm/sec) in contrast to GCLs, which are sheets of very low hydraulic conductivity, composite barrier material. The geomembrane polymeric types used for refuse disposal applications include: (1) chlorinated polyethylene (CPE), (2) chlorosulfonated polyethylene (CSPE), also called "Hypalon," (3) high-density polyethylene (HDPE) and (4) polyvinyl chloride (PVC). Of these types, PVC and HDPE are the most commonly used because they are lowest in cost and widely available.

GCLs consist of dry bentonite clay soil between two geotextiles or on a geomembrane carrier. Geomembranes and GCLs are manufactured in sheets and delivered to the site in rolls. The geotextiles used above and below the dry clay may or may not be connected with threads or fibers to increase the in-plane strength. Geomembrane rolls are seamed in the field using thermal methods or solvents, and GCLs are overlapped in the field to create a continuous barrier. At refuse disposal sites, geomembranes and GCLs are used as hydraulic barriers to limit seepage from impoundments into the groundwater and underground mines.

Although not required by MSHA, some state agencies that regulate coal refuse disposal facilities may require linings to control seepage. While placement of a low-hydraulic conductivity, compacted soil liner is permitted, some sites have insufficient material for constructing such a liner. Therefore, geomembrane and geosynthetic clay liners are more commonly used at these sites.

Leakage, rather than hydraulic conductivity, is the primary design concern for geomembrane-lined containment structures. Leakage can occur through poor field seams, poor factory seams, pinholes from manufacture, and puncture holes from handling, placement, or in-service activity. Leakage of geomembrane liner systems can be minimized by specification of an appropriate liner material and implementation of QA/QC procedures during installation.

The quality of geosynthetic material installation can be controlled by testing. [Tables 6.37, 6.38](#) and [6.39](#) identify applicable quality control test methods published by ASTM or the Geosynthetic Research Institute (GRI) for geotextiles, geomembranes and GCLs, respectively. Laboratory testing such as the gradient ratio test described in ASTM D 5101, “Standard Test Method for Measuring the Soil-Geotextile System Clogging Potential by the Gradient Ratio,” can be employed to check for clogging of geotextiles used for filtration. “Geotextile Filter Performance via Long Term Flow (LTF) Tests” (GRI Method GT1) should also be considered. In the design of a slurry impoundment, if a geotextile is to be used instead of a granular filter in a location where clogging of the geotextile would adversely affect the safety of the embankment, testing should be performed with site-specific materials to demonstrate that significant clogging of the geotextile will not occur during the design life of the filter. Additionally, as discussed in [Section 6.6.2.3.2](#), sufficient field instrumentation to monitor the phreatic level near critical drain and filter installations is recommended.

6.5.6 Consolidation Tests

Applying loads to coal refuse and underlying foundation materials causes compressive strains that are either immediate or time-dependent. Immediate strains are usually the result of elastic deformation of solids and compression of voids that are not held open temporarily by trapped pore water. Time-dependent strain is referred to as consolidation and is a function of the movement of pore water.

Immediate strain is common to soils with a low degree of saturation and/or a high hydraulic conductivity. This type of deformation is usually not an important part of the design of an embankment because the resulting movements are generally complete by the end of embankment construction. Situations where immediate strain should be considered include:

- Horizontal and vertical movement of a pipe within the embankment that could cause opening of joints, cracking of the pipe material or changes in the slope of drainage pipes. Special pipes are available that are flexible or have joints that allow longitudinal movement and slight bending.
- Movement beneath rigid structures, such as concrete spillways, that can be cracked or hydraulically affected by differential movement.

The behavior of saturated, fine-grained soils under stress can be very important in disposal facility design. Compressive strain in these soils can occur only through drainage of water from the pores because, at the stresses experienced during construction, both the soil particles and the pore water are essentially incompressible. Therefore, most of the strain occurs slowly, possibly over several months or years. This slow compressive strain is termed consolidation. With saturated fine-grained soils, the major portion of the total strain is due to consolidation. Until the drainage occurs, the excess pore-water pressures can reduce the effective strength of the material and cause instability.

Consolidation can be an important design consideration because, in addition to causing damage to pipes and structures, it can affect the gradient of surface drainage structures and the integrity of a cap following abandonment. The problems it creates may not become apparent until after the disposal facility begins operation, when corrections are most expensive. If an embankment is constructed over soft clay deposits or previously settled fine refuse, the movements resulting from consolidation can be especially large and the excess pore-water pressures can cause instability. Additional problems that can result from consolidation include:

- Settlement of the embankment crest below the design elevation
- Differential settlement that disrupts internal drains
- Cracking of the embankment, particularly in areas where large differential settlements occur over small distances, such as where soft foundation materials abut harder soil or rock at the base of a valley wall

TABLE 6.37 METHODS FOR QUALITY CONTROL TESTING OF GEOTEXTILES

Description	Test Method
Standard Test Method for Biological Clogging of Geotextiles or Soil/Geotextile Filters	ASTM D 1987
Standard Practice for Sampling of Geosynthetics for Testing	ASTM D 4354
Standard Test Methods for Water Permeability of Geotextiles by Permittivity	ASTM D 4491
Standard Test Method for Trapezoid Tearing Strength of Geotextiles	ASTM D 4533
Standard Test Method for Tensile Properties of Geotextiles by the Wide-Width Strip Method	ASTM D 4595
Standard Test Method for Grab Breaking Load and Elongation of Geotextiles	ASTM D 4632
Test Method for Determining the (In-plane) Flow Rate per Unit Width and Hydraulic Transmissivity of a Geosynthetic Using a Constant Head	ASTM D 4716
Standard Test Method for Determining Apparent Opening Size of a Geotextile	ASTM D 4751
Standard Test Method for Index Puncture Resistance of Geotextiles, Geomembranes and Related Products	ASTM D 4833
Standard Test Method for Measuring the Soil-Geotextile System Clogging Potential by the Gradient Ratio	ASTM D 5101
Standard Test Method for Permittivity of Geotextiles Under Load	ASTM D 5493
Standard Test Method for Hydraulic Conductivity Ratio (HCR) Testing of Soil/Geotextile Systems	ASTM D 5567
Standard Test Method for Biological Clogging of Geotextile of Soil/Geotextile Filters	ASTM D 1987
Geotextile Filter Performance via Long Term Flow (LTF) Tests	GRI Test Method GT1
Fine Fraction Filtration Using Geotextile Filters	GRI Test Method GT8

- Restrictions on the rate of fill placement over previously deposited fines
- Settlement of abandoned facilities that disrupts cap integrity and positive surface drainage control

The conventional laboratory test for measuring the consolidation characteristics of a fine-grained soil consists of trimming an approximately 1-inch-thick undisturbed soil sample in a metal ring that prevents lateral expansion. This test is described in ASTM D 2435, "Standard Test Methods for One-Dimensional Consolidation Properties of Soils Using Incremental Loading." Porous stones above and below the sample allow excess pore water to drain from the soil as it is subjected to a series of load and unload cycles. Application of a constant vertical load to the sample permits measurement of compression with time. When compression stops, the sample is said to be 100 percent consolidated under the applied load. The load is subsequently removed and the sample undergoes a small rebound. The load is then increased and held constant until the compression stops again. This procedure is continued for several cycles of loading and unloading, and a relationship is developed between the applied load and the compression produced. It is convenient to express the relationship between sample compression and load, as shown in [Figure 6.37](#), such that the logarithm of the applied load is plotted on the horizontal axis and the compression is plotted on the vertical axis in terms of the void ratio of the sample (as the sample is compressed, the void ratio decreases).

TABLE 6.38 METHODS FOR QUALITY CONTROL TESTING OF GEOMEMBRANES

Description	ASTM Test Method
Standard Practice for Sampling of Geosynthetics for Testing	D 4354
Standard Practice for Determining the Integrity of Field Seams Used in Joining Flexible Polymeric Sheet Geomembranes	D 4437
Standard Practice for Determining the Integrity of Factory Seams Used in Joining Manufactured Flexible Sheet Geomembranes	D 4545
Standard Test Method for Index Puncture Resistance of Geotextiles, Geomembranes and Related Products	D 4833
Standard Test Method for Determining Performance Strength of Geomembranes by the Wide Strip Tensile Method	D 4885
Standard Test Method for Determining the Coefficient of Soil and Geosynthetic or Geosynthetic and Geosynthetic Friction by the Direct Shear Method	D 5321
Standard Test Method for the Determination of Pyramid Puncture Resistance of Unprotected and Protected Geomembranes	D 5494
Standard Test Method for Large Scale Hydrostatic Puncture Testing of Geosynthetics	D 5514
Standard Test Method for Multi-Axial Tension Test for Geosynthetics	D 5617
Standard Practice for Geomembrane Seam Evaluation by Vacuum Chamber	D 5641
Standard Practice for Pressurized Air Channel Evaluation of Dual Seamed Geomembranes	D 5820
Standard Test Method for Determining Tearing Strength of Internally Reinforced Geomembranes	D 5884
Standard Guide for Selection of Test Methods to Determine Rate of Fluid Permeation Through Geomembranes for Specific Applications	D 5886
Standard Test Method for Measuring Core Thickness of Textured Geomembrane	D 5994
Standard Test Method for Determining the Integrity of Field Seams Used in Joining Geomembranes by Chemical Fusion Methods	D 6214
Standard Practice for the Nondestructive Testing of Geomembrane Seams using the Spark Test	D 6365
Standard Test Method for Determining the Integrity of Non-reinforced Geomembrane Seams Produced Using Thermo-Fusion Methods	D 6392
Standard Guide for the Selection of Test Methods for Flexible Polypropylene (FPP) Geomembranes	D 6434
Standard Guide for Selection of Techniques for Electrical Detection of Potential Leak Paths in Geomembrane	D 6747
Standard Practice for Leak Location on Exposed Geomembranes Using the Water Puddle System	D 7002
Standard Test Method for Strip Tensile Properties of Reinforced Geomembranes	D 7003
Standard Test Method for Grab Tensile Properties of Reinforced Geomembranes	D 7004
Standard Practice for Ultrasonic Testing of Geomembranes	D 7006

TABLE 6.38 METHODS FOR QUALITY CONTROL TESTING OF GEOMEMBRANES
(CONTINUED)

Description	ASTM Test Method
Standard Practices for Electrical Methods for Locating Leaks in Geomembranes Covered with Water or Earth Materials	D 7007
Standard Test Method for Determining the Tensile Shear Strength of Pre-Fabricated Bituminous Geomembrane Seams	D 7056
Standard Specification for Non-Reinforced Polyvinyl Chloride (PVC) Geomembranes Used in Buried Applications	D 7176
Standard Specification for Air Channel Evaluation of Polyvinyl Chloride (PVC) Dual Track Seamed Geomembranes	D 7177
Standard Practice for Leak Location using Geomembranes with an Insulating Layer in Intimate Contact with a Conductive Layer via Electrical Capacitance Technique (Conductive Geomembrane Spark Test)	D 7240

As shown in [Figure 6.37](#), the steeper slope of the void ratio versus log effective stress plot is defined as the compression index C_c . The flatter slope of the void ratio versus log effective stress plot is defined as the recompression index C_{cr} . Typically, C_{cr} is in the range of 0.1 to 0.2 C_c . The compression index is typically used for estimating consolidation settlement of normally consolidated soils and fines. Procedures for determining C_c and C_{cr} are presented in ASTM D 2435. Presenting the test results in the form shown in [Figure 6.37](#) simplifies computation of the estimated compression for a given increment of applied load. Most standard texts on soil mechanics include comprehensive discussions of this test and procedures for using the test data to predict settlement.

Consolidation testing also provides information regarding the time rate of settlement as a function of consolidation stress. The time rate of consolidation settlement is defined by the coefficient of vertical consolidation c_v and the coefficient of horizontal consolidation c_h . The parameter c_v can be used for estimating vertical pore pressure dissipation with time, which is useful for evaluating the rate of consolidation settlement of fills that are large in areal extent. The parameter c_h can be used for estimating horizontal pore pressure dissipation with time, which is important in the design of wick drains. Procedures for determining c_v and c_h are presented in ASTM D 2435. Values for c_v and c_h determined from laboratory consolidation results tend to be conservative (i.e., underpredict the rate of pore-pressure dissipation) and can vary significantly from in-situ values. More reliable values of c_v and c_h can usually be obtained by conducting a dissipation test during piezocone testing ([Section 6.4.3.7](#)) or by monitoring piezometers.

TABLE 6.39 METHODS FOR QUALITY CONTROL TESTING OF GEOSYNTHETIC CLAY LINERS

Description	ASTM Test Method
Standard Guide for Storage and Handling of Geosynthetic Clay Liners	D 5888
Standard Test Method for Determining the Internal and Interface Shear Resistance of Geosynthetic Clay Liner by the Direct Shear Method	D 6243
Standard Guide for Acceptance Testing Requirements for Geosynthetic Clay Liners	D 6495
Standard Test Method for Tensile Strength of Geosynthetic Clay Liners	D 6768

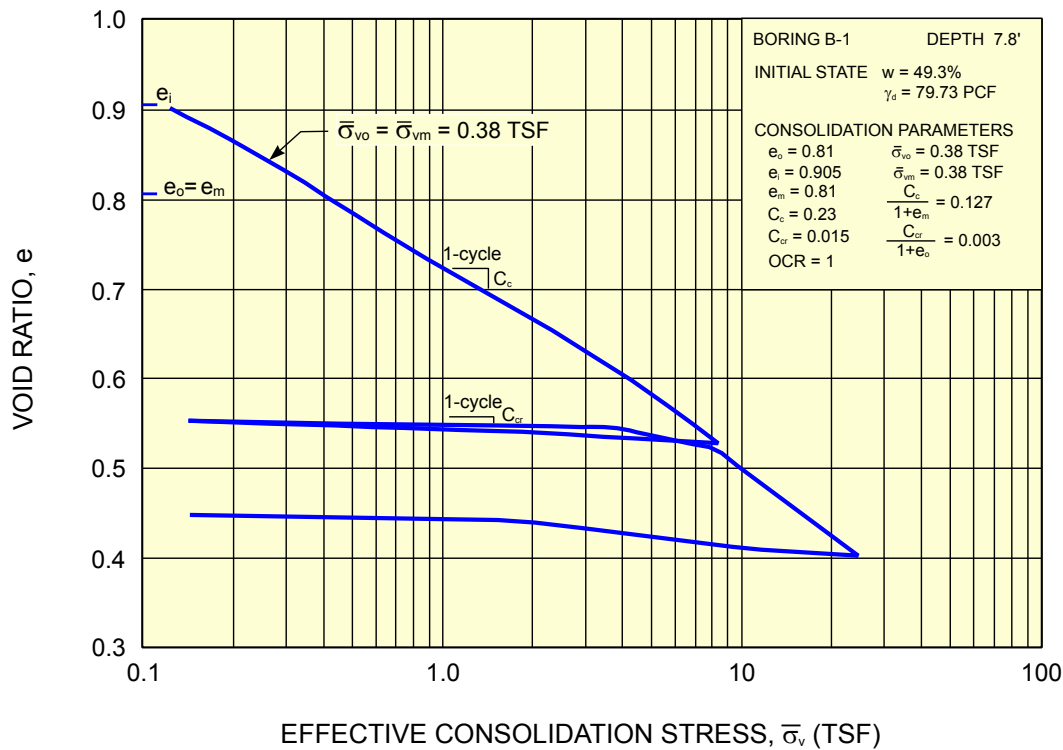

FIGURE 6.37 RESULTS OF CONSOLIDATION TEST ON FINE COAL REFUSE

Coarse coal refuse is normally placed at a moisture content below saturation and is usually sufficiently coarse-grained that consolidation is not a consideration. On the other hand, consolidation of fine coal refuse is important, especially in the design of disposal facilities developed using the upstream method of construction. Consolidation effects should be considered if the incremental increase in height of an embankment constructed on settled fine coal refuse is greater than several feet and the embankment supports drainage structures or seepage barriers that could be impacted by differential settlement. Consolidation parameters may also be estimated from the results of triaxial shear strength tests.

Published data for typical ranges of consolidation parameters for coal refuse are limited. Almes and Butail (1976) report that C_c for saturated fine coal refuse varies between 0.2 and 0.3 at moisture contents ranging between 30 and 45 percent. Hegazy et al. (2004) present values for the horizontal coefficient of consolidation c_h determined from piezocone testing in fine coal refuse deltas at disposal sites in western Pennsylvania. The values of c_h range from $15 \times 10^{-3} \text{ cm}^2/\text{sec}$ to $300 \times 10^{-3} \text{ cm}^2/\text{sec}$. These results are typical of coefficient of consolidation values reported for sandy silt to silty clay soils (Bardet, 1997).

6.5.7 Shear Strength and Related Tests

The shear strengths of soil and coal refuse materials used to construct an embankment, or used as the embankment foundation, are needed for stability analysis of the embankment. Stability analyses are discussed more extensively in [Section 6.6.4](#). Shear strengths are also needed for determination of the allowable bearing pressure for structures founded on or within the embankment and for the stability of slopes cut during embankment construction.

Embankment and foundation stability may be evaluated using either “total stress” or “effective stress” methods. The method selected depends on the:

- Embankment material or materials
- Foundation conditions

- Magnitude of pore-water pressures within the embankment
- State of construction or use for which embankment stability is to be evaluated

Total stress is a combination of the stress between the individual soil grains, termed “effective stress,” and the pressure of the pore water, termed “pore pressure.” Because pore water has no shear resistance, all shear resistance is represented by the effective stress. The shear stress at failure (ultimate shear strength) on any surface within an embankment is directly related to the stress normal to the failure surface, because the failure mechanism involves friction of one body moving on another and apparent bonding. This relationship can be expressed as:

$$\tau_{max} = c' + (\sigma - u) \tan \phi' = c' + \sigma' \tan \phi' \quad (6-12)$$

where:

- τ_{max} = shear stress on surface at failure (force/length²)
- c' = effective cohesion (force/length²)
- ϕ' = angle of effective internal friction (degrees)
- σ = total stress acting normal to the failure surface (force/length²)
- u = pore-water pressure acting on the failure surface (force/length²)
- σ' = effective stress acting normal to the failure surface (force/length²)

The following paragraphs describe the above two approaches and their application to refuse embankment design.

For shear strength tests conducted for a total stress analysis, water is not allowed to drain from the sample during shearing. This method of stability analysis and related types of analyses (Section 6.6.4) are generally considered most appropriate for evaluating relatively short-term conditions that would occur: (1) during and immediately after construction, (2) immediately following rapid changes in the impoundment level, (3) during pushouts, and (4) during seismic loadings. Tests typically used to develop strength parameters for a total-stress analysis include the vane shear test, the unconfined compression test and the unconsolidated-undrained (UU) triaxial test. For these tests, the strength does not increase with increasing normal stress if the soil is saturated. Total stress analysis parameters can also be calculated from the consolidated-undrained (CU) triaxial shear test.

Shear strength tests for an effective-stress analysis either allow water to drain from the samples during testing or provide for measurement of the pore pressures under loading and confining conditions that are intended to simulate actual field conditions. Effective-strength parameters apply to all soil types, including gravels, sands, silts, and clays. This method of stability analysis and related types of analyses (Section 6.6.4) are generally considered most appropriate for evaluating long-term conditions after the temporary effects of construction on pore pressures have dissipated and seepage rates become steady. The tests typically used to develop effective-stress strength parameters include: (1) consolidated-undrained triaxial shear tests with pore-water pressure measurements (\overline{CU}), (2) consolidated-drained triaxial tests at slow strain rates (CD), or (3) drained direct shear tests. For these tests, the strength increases with increasing normal stress. For long-term analyses, the drained test strength parameters are the effective cohesion intercept c' and effective friction angle ϕ' from the effective stress Mohr-Coulomb envelope. The shear strength τ_{max} is given by:

$$\tau_{max} = c' + \sigma' \tan \phi' \quad (6-13)$$

For analysis purposes, c' is often assumed to be zero because laboratory tests are affected by loading rate and duration effects. In this situation, the cohesion component of strength can be likened to a bond that weathers with time (Mesri and Abdel-Ghaffar, 1993).

Sample preparation for laboratory shear strength tests is an essential aspect of a testing program, if the tests are to accurately reflect field conditions. Undisturbed, disturbed and remolded or compacted samples may be tested depending on the soil and material conditions to be modeled in the total- or effective-stress analyses. For shear strength tests on proposed embankment construction materials, the materials are compacted to the densities and moisture contents that are anticipated to occur within the embankment. Tests for the shear strength of coarse-grained foundation soils are performed on samples that are reconstituted in the laboratory to simulate the in-situ conditions. Tests for the shear strength of fine-grained foundation soils are performed on undisturbed samples obtained from borings or test pits.

Triaxial and direct shear test results are presented either as a series of Mohr's circles or stress paths that reflect sample failure conditions. A Mohr's circle presentation is typically used for UU triaxial and direct shear test results, while a stress path presentation is used for \overline{CU} and CD triaxial test results. An example Mohr's circle presentation is shown in Figure 6.38, and a stress path presentation is provided in Figure 6.39. As shown in Figure 6.38, a Mohr's circle for each test is drawn on a plot of shear stress τ versus normal stress σ by drawing a circle that connects the maximum and minimum principal stresses on the sample at failure (i.e., σ_{1f} and σ_{3f} , respectively). Failure is then defined by a straight or curved line drawn tangent (or nearly tangent) to the series of circles on the plot. The inter-

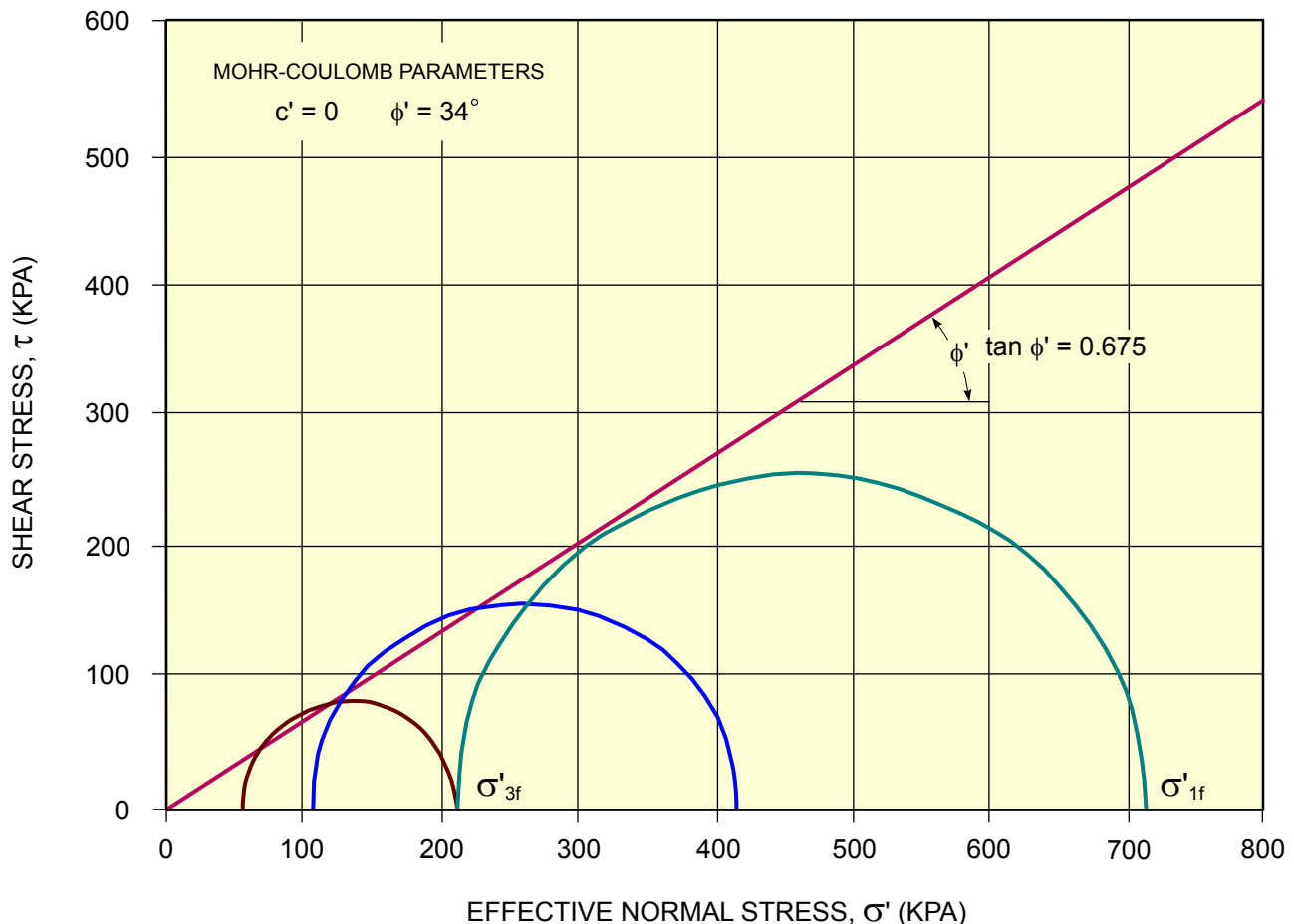

FIGURE 6.38 EFFECTIVE STRESS MOHR'S CIRCLE FOR \overline{CU} TRIAXIAL TEST

cept of the line with $\sigma = 0$ is referred to as the total stress cohesion intercept c and the angle of the line to the horizontal is the total stress angle of friction ϕ .

As shown in Figure 6.39, the stress path for each test is constructed on a plot of $(\sigma_1' + \sigma_3')/2$, or p , versus $(\sigma_1' - \sigma_3')/2$, or q , where values of p and q are plotted for each load increment in each test. Failure is defined by a straight or curved line connecting values of $(q/p)_{max}$ for each stress path. The intercept of this line with the p axis (a) can be represented as $a = c' \cos \phi'$, where the angle to the horizontal of the line connecting values of $(q/p)_{max}$ for each stress path is α and $\tan \alpha = \sin \phi'$. Then the effective angle of friction $\phi' = \arcsin(\tan \alpha)$ and $c' = a/\cos \phi'$.

Many soils exhibit stress-strain behavior that varies with confinement. This behavior is referred to as stress dependency and can be characterized by the stress path method. A stress path is a numerical and graphical representation of the past, present and future state of stress on a representative soil element because it captures the geologic stress history of the element, the current stresses acting on the element, and the anticipated future changes in stress on the element. The stress path of a material is determined by plotting the effective strength from \overline{CU} and CD triaxial tests for each load increment of the tests. Using the stress path method, the test results are then analyzed with respect to the approximate field stress and strain conditions before, during, and after construction (Lambe, 1967; Lambe and Marr, 1979).

Determining the appropriate strength parameters for evaluating the stability of any embankment, regardless of size or location, should be performed by a person experienced in the engineering behavior of soil, rock and refuse materials. The complexity of laboratory shear strength test procedures for modeling expected field conditions requires that laboratory shear strength testing be conducted with

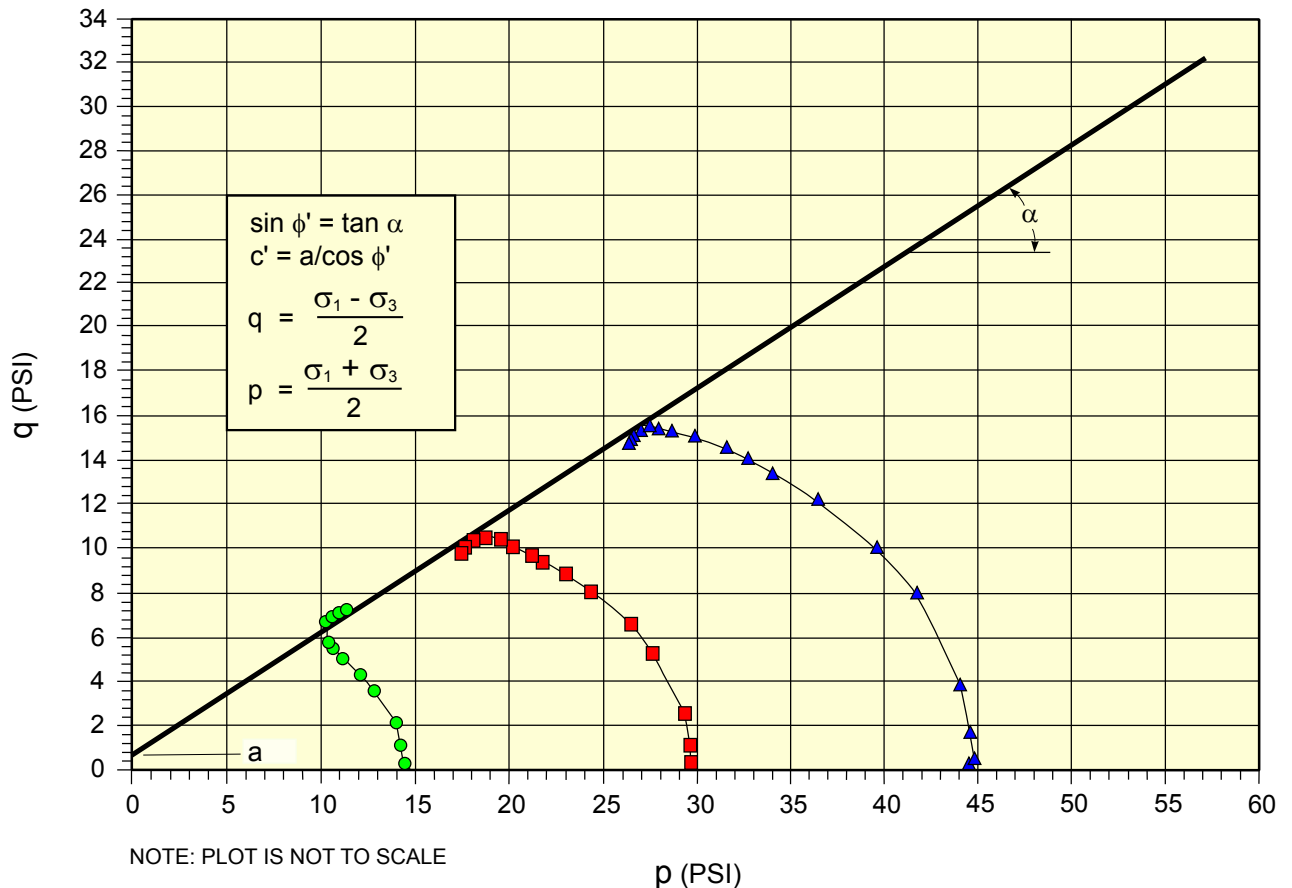

FIGURE 6.39 EFFECTIVE STRESS PATHS AND FAILURE ENVELOPE FOR \overline{CU} TRIAXIAL TEST

greater care and more professional scrutiny than routine tests. Shear strength testing must be tailored to site conditions by a qualified geotechnical engineer familiar with the type of embankment to be constructed and foundation conditions. The tests should be conducted by laboratories with appropriate equipment and skilled technicians.

Standard shear strength test methods are: (1) vane-shear, (2) direct-shear, (3) unconfined-compression, and (4) triaxial-compression. The applicability of these tests to various soil types is presented in [Table 6.40](#). Descriptions of these tests are provided in the following sections. Head (1982, 1986) and Bardet (1997) discuss other methods for determining shear strength.

6.5.7.1 Vane-Shear Test

The laboratory vane-shear test is used to determine the undrained shear strength s_u using the test method described in ASTM D 4648, "Standard Test Method for Laboratory Miniature Vane Shear Test for Saturated Fine-Grained Clayey Soil." Similar to the field vane-shear test ([Section 6.4.3.8](#)), the laboratory vane-shear test is conducted on very soft to stiff, fine-grained, undisturbed, remolded or reconstituted, cohesive soil by inserting a four-bladed vane into a soil sample and rotating it such that shearing occurs along a cylindrical surface. The undrained shear strength is determined from the resistance to rotation. The miniature vane is similar to the field vane-shear device, except that it has a smaller blade diameter (0.5 inch) and blade height (1 inch). After s_u is determined, the residual (minimum) shear strength s_{ur} is determined by quickly rotating the vane 10 full rotations (to fully remold the soil) and then conducting a second shear test. The ratio of peak to remolded undrained shear strength is the sensitivity S_r . The laboratory vane test is typically conducted on a vertically oriented sample because that is the direction in which the soil sample is taken in the field. If the sample is rotated 90 degrees from the vertical, the laboratory vane test can be used to measure soil anisotropy. Laboratory vane shear testing of fine coal refuse is not recommended. Instead, the strength of fine coal refuse should be determined in situ using the CPT, PCPT methods or the field vane-shear test, as described in [Section 6.4.3.8](#), or by laboratory testing using the direct-shear or triaxial-compression test methods described in [Sections 6.5.7.2](#) and [6.5.7.4](#), respectively.

6.5.7.2 Direct-Shear Test

The direct-shear test is the oldest and simplest form of shear test. Direct-shear tests are used for testing reconstituted cohesionless soils and undisturbed cohesive soils. The test method is particularly useful if the residual strength at large strain is desired. The test is conducted in accordance with ASTM D 3080, "Standard Test Method for Direct Shear Test of Soils under Consolidated Drained Conditions."

As shown schematically in [Figure 6.40](#), the direct-shear test is performed by placing a ½-inch-minimum-thickness specimen into a cylindrical (2-inch-minimum-diameter) or square-shaped (typically 3 or 4 inches) shear box that is split along a horizontal plane. The test specimen is confined top and bottom by porous stones, and the shear box is placed in a container to permit submergence and saturation of the specimen during testing. A vertical (normal) load is applied over the specimen and allowed to consolidate. The test is conducted by holding the upper or lower part of the box stationary and applying a horizontal load on the other part of the box to shear the specimen along a predefined horizontal plane. The shearing load applied at failure divided by the cross-sectional area of the soil sample is considered to be the shear stress at failure. The normal load divided by the cross-sectional area of the sample is considered to be the normal stress at failure. Direct shear tests of cohesionless soils are considered drained tests because of the high sample hydraulic conductivity. Depending on the rate of shearing, direct-shear tests of cohesive soils can be either undrained or drained.

After the maximum shear strength has been determined, the residual shear strength (c_r' and σ_r') can be determined by performing repeated and rapid cycles of shearing (usually a minimum of five full forward and reverse cycles) along the plane of failure mobilized during the initial portion of the test.

TABLE 6.40 LABORATORY TESTS FOR DETERMINING SOIL SHEAR STRENGTH

Type of Test	Relative Frequency of Use ⁽¹⁾				Preparation Prior to Applying Load	Drainage Conditions During Test	Parameters Determined	Remarks
	Coarse-grained Soils	Fine-grained Soils	Coarse Refuse	Fine Refuse				
<u>Direct Shear</u>								
• Drained	1	3	1	1	Consolidated Under Normal Load	Drained	Effective Stress	Difficult to control rate of test to assure drained condition
• Undrained	NA	3	NA	NA	Consolidated Under Normal Load	Undrained	Approximate Total Stress	Difficult to conduct quickly enough to assure no drainage
<u>Triaxial</u>								
• Unconsolidated-Undrained (UU)	NA	2	NA	3	Unconsolidated	Undrained	Approximate Total Stress	Also called Quick (Q) test
• Consolidated-Undrained (CU)	1	1	1	1	Consolidated Under Isotropic Pressure	Undrained	Total Stress and Effective Stress	Pore pressures are measured to give effective stress condition
• Consolidated-Drained (CD)	2	1	2	1	Consolidated Under Isotropic Pressure	Drained	Effective Stress	Also called Slow (S) test
<u>Unconfined</u>	NA	2	2	NA	Unconsolidated	Undrained	Approximate Total Stress	Sample must have sufficient cohesion to maintain shape without support

Note: 1. 1 = frequently used
 2 = occasionally used
 3 = applicable, but seldom used
 NA = not applicable

The repeated cycles of loading are intended to simulate large straining in the field that would be typical of a slope failure. Once the cycles of repeated shearing are complete, excess pore pressures in the test specimen are allowed to dissipate under constant normal load. When the excess pore-water pressures equilibrate (i.e., consolidation is complete), the test specimen is sheared as previously described.

As shown in Figure 6.41a, a series of direct-shear tests (typically three minimum) is conducted using varying normal stress σ' . Test results are plotted in the form of shear stress τ versus horizontal displacement δ . A plot of the peak or failure shear stress τ versus σ' is used to determine the angle of internal friction and cohesion intercept, as shown in Figure 6.41b. For most soils, a line drawn through the points for each test is approximately straight. This line is termed the failure envelope. The angle that the line makes with the horizontal axis is a measure of the component of strength due

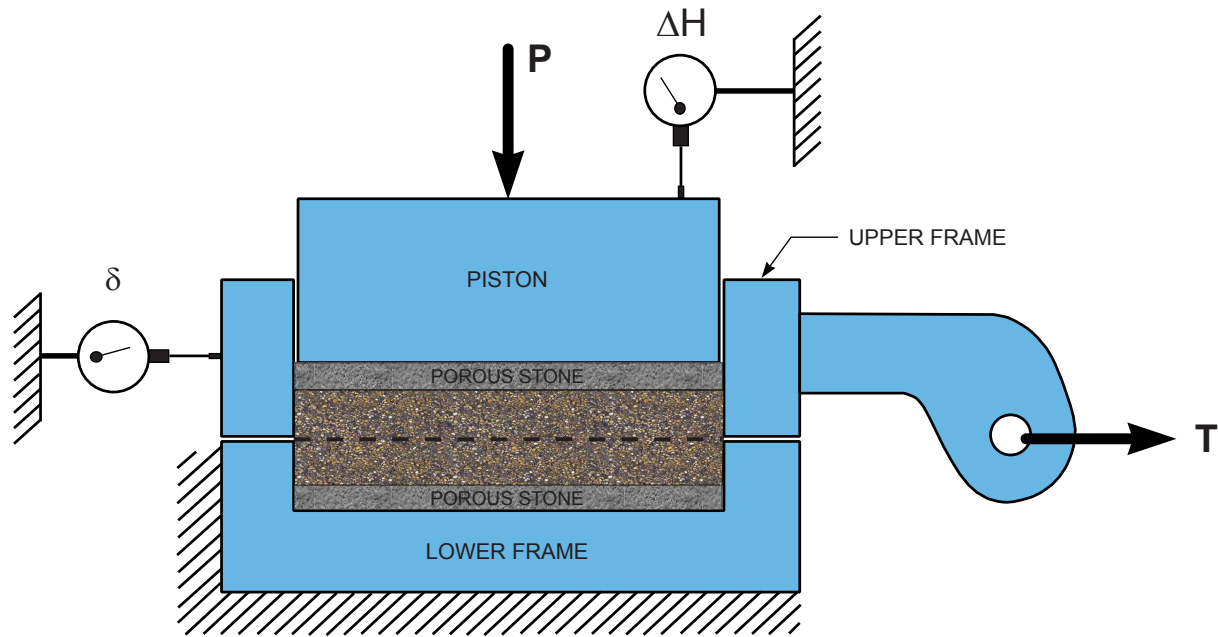

(MAYNE ET AL., 2002)

FIGURE 6.40 DIRECT SHEAR TESTING ARRANGEMENT

to friction between the soil particles and is termed the angle of effective internal friction ϕ' . When the line intercepts the vertical axis at a value greater than zero, the intercept is referred to as the effective cohesion c' .

Direct-shear tests are simple and can be performed relatively quickly. However, the test has several inherent shortcomings due to the forced plane of shearing:

- The failure plane is predefined and horizontal and may not be the weakest plane in the sample.
- There is little control over the drainage of the soil.
- The height cannot be defined for calculating shear strains, so a stress-strain modulus cannot be determined from the test.
- Stress conditions on the failure surface are non-uniform and failure develops progressively (the entire strength of the specimen is not mobilized simultaneously at all points on the failure surface), so measured strength values are lower than would be obtained under uniform stress conditions.
- Stress conditions are known only at failure.

6.5.7.3 Unconfined-Compression Test

The unconfined-compression test is conducted on cohesive soils in accordance with ASTM D 2166, "Standard Test Method for Unconfined Compressive Strength of Cohesive Soil." Cohesive soil specimens are tested to failure by rapidly applying an axial load. Measurements of axial force and axial deformation are made during the test, and the test results are presented as a plot of axial stress versus axial strain as shown in Figure 6.42. The maximum measured force over the sample cross section q_u is the axial stress, and the peak value of axial stress divided by 2 is the undrained shear strength s_u . For a total stress analysis, the unconfined-compression test provides an approximate measure of the short-term, undrained strength of the soil at the density and moisture content of the sample. It provides no information about long-term strength properties appropriate for an effective stress analysis.

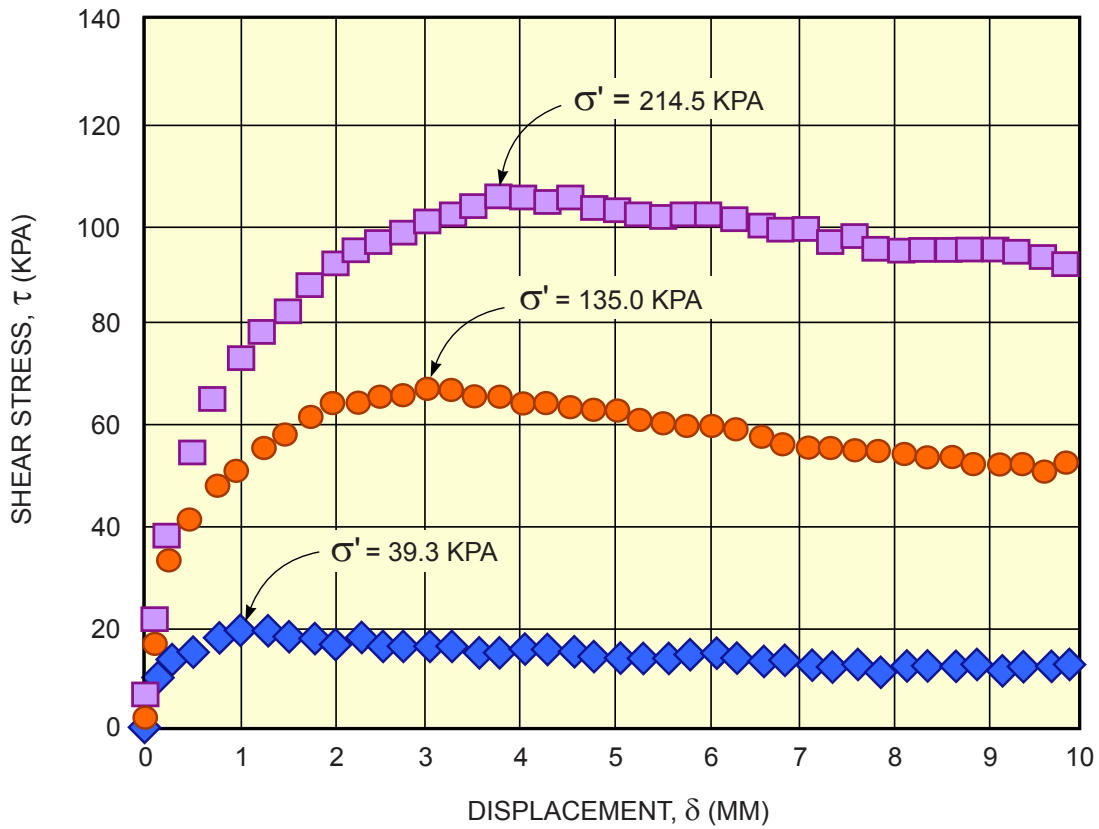

6.41a SHEAR STRESS VS. DISPLACEMENT

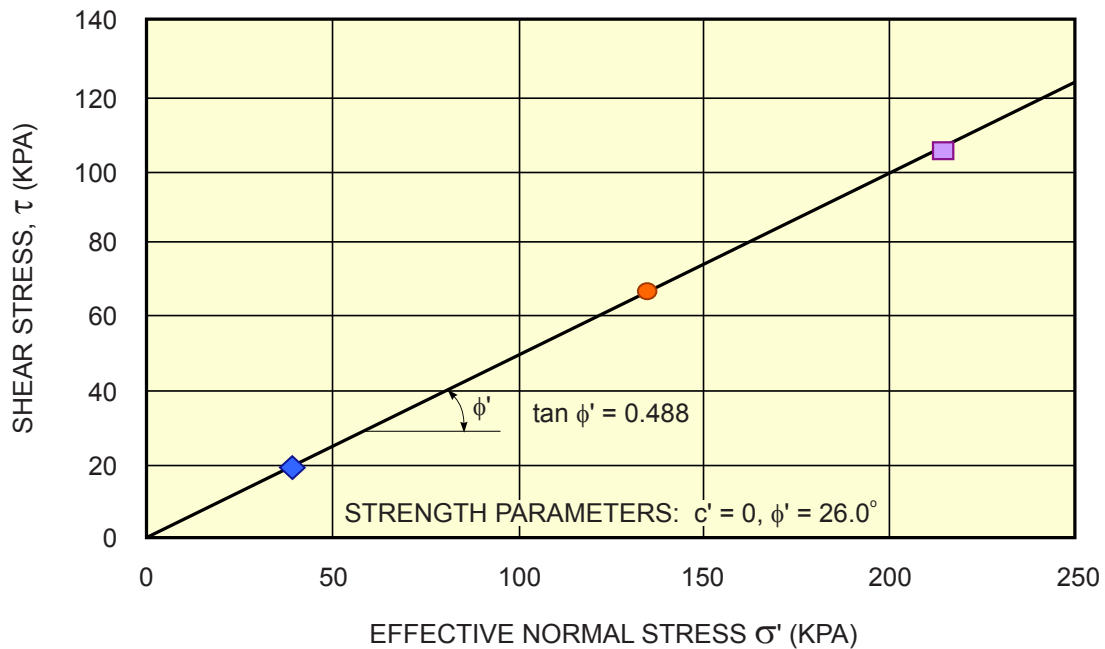

6.41b SHEAR STRESS VS. EFFECTIVE NORMAL STRESS

NOTE: DATA BASED UPON DIRECT SHEAR TEST OF TRIASSIC CLAY IN RALEIGH, NC

(MAYNE ET AL., 2002)

FIGURE 6.41 RESULTS OF DRAINED DIRECT SHEAR TEST ON CLAY

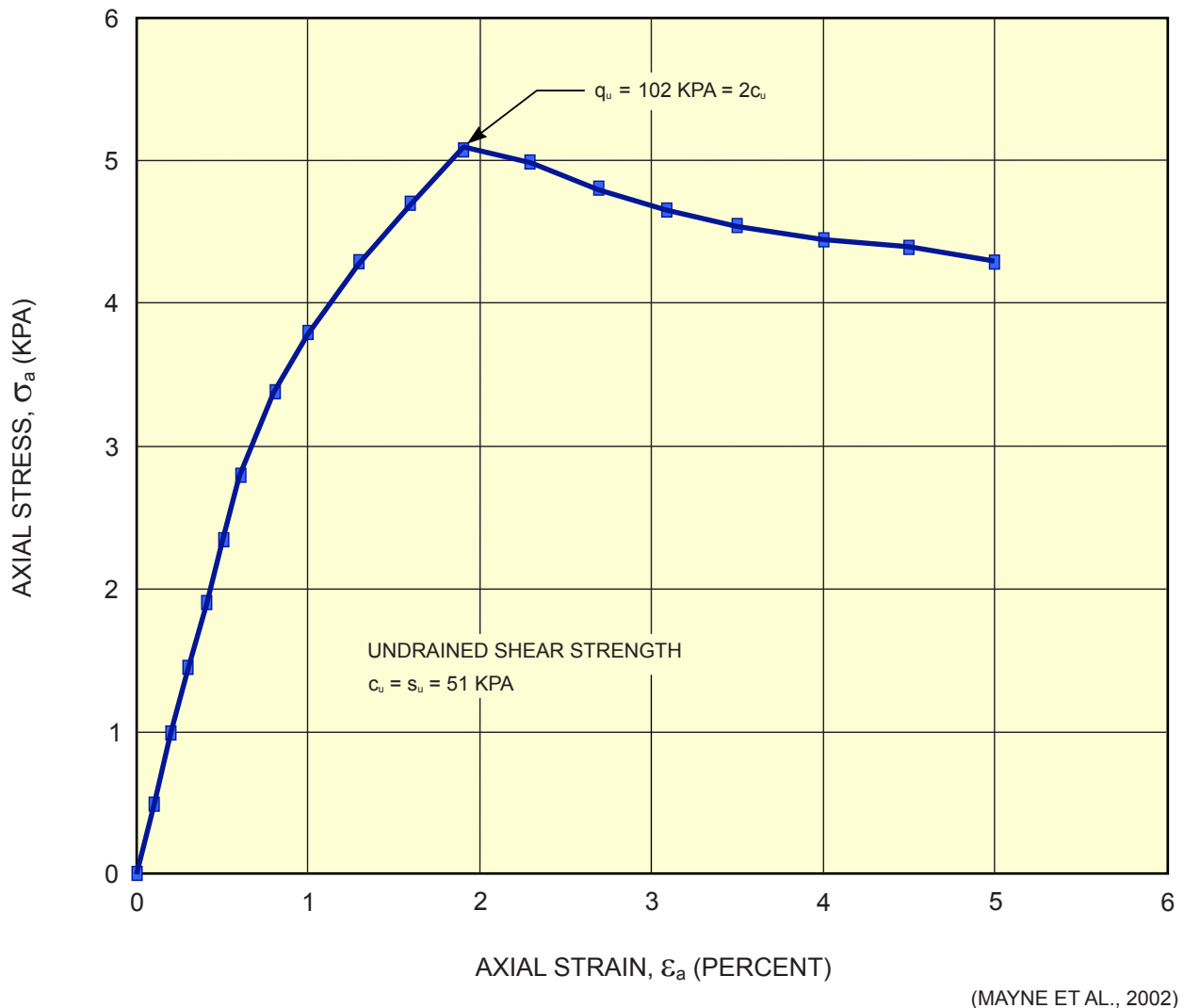

FIGURE 6.42 UNCONFINED COMPRESSION TEST RESULTS

The unconfined-compression test can be performed using undisturbed, remolded or compacted soil samples. The stress-strain curves and failure modes observed during testing provide an index value of the soil properties in addition to strength. For example, bulging or yielding of the sample signifies a relatively soft clay, while a sudden brittle failure indicates a desiccated clay or cemented material. The stress-strain curves developed from these tests should be used with caution when determining the soil modulus for input to numerical analyses (e.g., finite element analysis) because they are very sensitive to minor variations of the modulus.

Test specimens with inclined fissures, sand and silt lenses or slickensides have a tendency to fail prematurely along these weaker planes in unconfined compression tests. If these failure modes occur, more sophisticated testing, such as triaxial tests, may be needed to obtain a more realistic determination of the in-situ strength.

6.5.7.4 Triaxial-Compression Test

The triaxial test is used to determine strength and stress-strain behavior of undisturbed, remolded or reconstituted soil samples. To conduct a triaxial test, cylindrical samples are consolidated, usually isotropically, and then sheared in axial compression. Undrained and drained testing can be conducted, and pore-water pressures can be measured during undrained shear tests. Triaxial tests pro-

vide a reliable means for determining: (1) the undrained strength of cohesive soils, (2) the angle of friction and cohesion intercept of undisturbed, reconstituted and compacted soils, and (3) the soil modulus at intermediate to large strains.

Test specimens are typically 1.4 to 2.8 inches in diameter with a height to width ratio between 2 and 2.5. Selection of the sample diameter is governed by limitation of the maximum particle size in the test specimen to not more than one-sixth of the sample diameter. Thus, the maximum particle size for a 1.4-inch-diameter sample is about $\frac{1}{4}$ inch and for a 2.8-inch-diameter specimen about $\frac{1}{2}$ inch. If the soil to be tested has large-size particles, then sufficiently large-diameter specimens should be used so that the sample diameter is more than six times the maximum particle size. Otherwise, the tested sample should be modeled or scalped using the procedures recommended by Becker et al. (1972) and summarized in Duncan and Wright (2005)

Modeling entails creating a modeled particle-size distribution that parallels the original gradation, where the maximum particle size does not exceed one-sixth of the diameter of the tested sample. Using this approach, Becker et al. (1972) determined that strength test results using the modeled gradation were essentially the same as the strength of the original gradation that had been tested using sufficiently large diameter samples to meet the one-sixth criterion provided the test specimens were prepared to the same relative density (Section 6.5.3.2).

Scalping entails using that portion of the sample that remains after sieving to remove particle sizes that exceed the one-sixth criterion. As with modeling, Becker et al. (1972) determined that strength test results using a scalped gradation were essentially the same as the strength of the original gradation provided that the test specimens were prepared to the same relative density. However, if either modeling or scalping is used to achieve an acceptable particle-size distribution for testing, additional testing to determine the minimum and maximum densities of both the original and modeled or scalped materials must be conducted to verify that the relative density of the modeled or scalped material is approximately equal to the relative density of the original material.

Of the options for achieving an acceptable particle-size distribution for testing, scalping is probably the simpler and less costly approach. Scalping also does not result in an appreciable shifting of the fines content, which could affect the strength test results if a substantial portion of over-size material must be removed for testing. While these procedures can be used for coal refuse, they should be applied with caution, particularly in cases where the characteristics (e.g., material type, angularity, surface roughness) of the smaller particles differ materially from those of the larger particles that were removed from the sample.

To conduct the triaxial test, a sample is enclosed by a thin rubber membrane and placed inside a cylindrical pressure chamber that is usually filled with water. The sample is subjected to a uniform confining pressure σ_3 by compression of the fluid in the chamber acting on the membrane. The range of σ_3 for a triaxial test series is generally selected so that the confining pressures are higher, lower and about equal to anticipated in-situ value of σ_3 at the end of construction. Using a range of σ_3 where all confining pressures are less than or equal to the anticipated in-situ value of σ_3 can result in overestimation of the strength and compressibility of the tested material, as compared to the in-situ material. Depending on the type of triaxial test conducted, a backpressure may be applied to the specimen through the end platens to saturate the specimen. The test sample is sheared to failure by applying an axial stress, typically referred to as the deviator stress ($\sigma_1 - \sigma_3$), through a vertical loading ram. Axial stress can be applied at a constant deformation rate (strain controlled) or by means of dead weight increments or hydraulic pressure (stress controlled) until the sample fails.

Triaxial tests can be used to simulate various in-situ loading conditions. The types of triaxial tests typically employed for this purpose include:

- Unconsolidated-undrained (UU or Q) test
- Consolidated-undrained (CU test)
- Consolidated undrained ($\overline{\text{CU}}$ or R) test with pore-pressure measurement
- Consolidated-drained (CD or S) test

UU (also referred to as quick or Q) triaxial tests are conducted on cohesive soils in accordance with ASTM D 2850, "Standard Test Method for Unconsolidated-Undrained Triaxial Compression Test on Cohesive Soils." The UU test provides only an approximation of the short-term or undrained strength for a total stress analysis and typically is conducted in order to provide data for preliminary analyses and for designing the final test program. The UU test does not provide data about the effective stress or long-term properties of the material. In a UU test, the specimen is not allowed to consolidate during application of σ_3 or to drain during the testing, so the strength measured is the undrained shear strength s_u . The rate of axial deformation during shear is comparable to the rate used for unconfined compression tests. The results of undrained tests depend on the degree of saturation S_r of the specimens. If $S_r \approx 100$ percent, testing of similar samples will provide similar values of s_u , because the shear strength of the test sample will not increase with increasing confining pressure. However, if $S_r \leq 95$ percent, increasing σ_3 may result in increasing values of s_u until the air voids compress and the sample becomes completely saturated.

If water is allowed to completely drain from a test sample when σ_3 is applied, the sample becomes uniformly consolidated. Two types of tests can be performed on consolidated samples. In the consolidated-undrained (CU) test, the consolidated sample is sheared by application of an axial test load without allowing any additional water to drain during the loading. Because the sample does not drain during loading, the results are suitable only for total stress analyses. The rate of strain used for the CU triaxial test is similar to that for the UU triaxial test.

If the pore pressure is measured while the sample is loaded, effective stress parameters can be calculated. This test is called a consolidated undrained with pore-pressure measurement ($\overline{\text{CU}}$ or R) triaxial test. The $\overline{\text{CU}}$ triaxial test permits determination of both total stress and effective stress (c' and ϕ') parameters. The rate of strain used for the $\overline{\text{CU}}$ triaxial test is much slower than for the UU or CU triaxial tests so that excess pore pressures equilibrate throughout the test specimen and pore-water pressures can be reliably measured at the ends of the test specimen. The CU test is performed in accordance with ASTM D 4767, "Standard Test Method for Consolidated Undrained Triaxial Compression Test for Cohesive Soils." The rate of strain used for the $\overline{\text{CU}}$ triaxial test is prescribed in ASTM D 4767 and is much slower than the rate of strain for UU triaxial tests. This permits equalization of excess pore pressures during undrained shearing so that the excess pore-water pressures measured at the end of the test specimen are not less than 95 percent of the excess pore-water pressure along the sample shear plane.

Consolidated-drained (CD) triaxial (also referred to as slow or S) tests also yield the effective stress parameters c' and ϕ' . The primary difference between the $\overline{\text{CU}}$ and CD triaxial tests is that the sample is allowed to drain during the CD test. The rate of strain used for CD tests is usually much slower than the rate used for $\overline{\text{CU}}$ tests, so that the development of excess pore pressures in the test sample is less than a few percent of the initial effective confining pressure σ_3' . The CD test measures only the effective stress parameters c' and ϕ' .

Triaxial test results are typically presented in Mohr's Circle or p-q plots, as described previously.

Typical values of the shear strength from triaxial testing of fine coal refuse, as reported by Hegazy et al. (2004) for sites in northern Appalachia, are summarized in [Table 6.41](#). Drained-shear-strength parameters were determined using consolidated isotropic undrained compression (CIUC) triaxial tests with pore-pressure measurements and consolidated isotropic drained compression (CIDC) tri-

TABLE 6.41 SUMMARY OF FINE COAL REFUSE SHEAR STRENGTH PARAMETERS BASED ON TRIAXIAL TEST RESULTS

Parameter	Average	Standard Deviation	Coefficient of Variation
ϕ'	33 degrees	4	0.12
c'	11 kPa	14	1.30
$\phi' (c' = 0)$	35 degrees	4	0.11

(HEGAZY ET AL., 2004)

axial tests. In this study, fine coal refuse samples from Shelby tubes were collected from beneath the upstream stages of a refuse embankment or from working platforms built over the fine coal refuse in the impoundment. Table 6.41 indicates that the variability of ϕ' is low to moderate, while the variability of c' is relatively high. The shear strength parameters presented in the table are peak values and were found to decrease with increasing fines contents, as shown in Figure 6.43.

Residual shear strength values at large strains determined in accordance with the cited ASTM standards are sometimes considered for the design of impoundments with upstream construction.

The test results in Table 6.41 and Figure 6.43 are presented for illustration purposes only, and strength characteristics will vary depending on the geology and coal extraction, processing, and disposal practices.

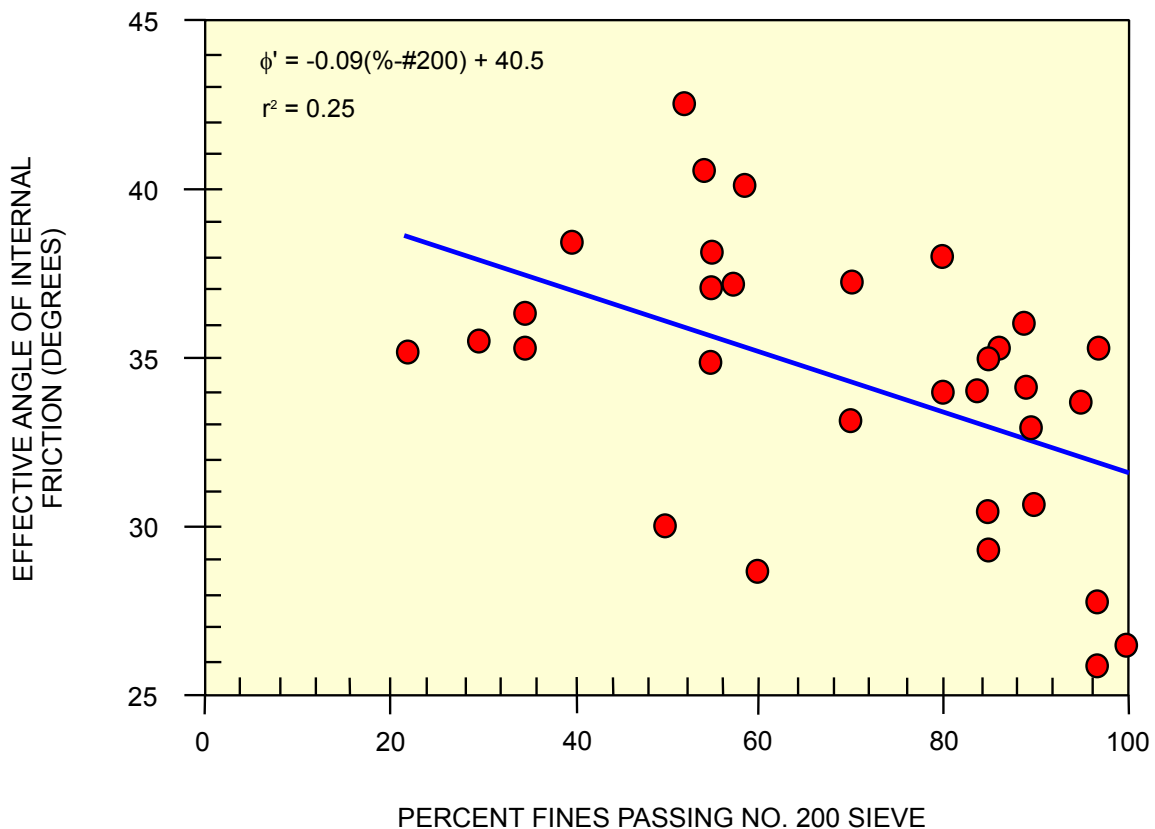

(HEGAZY ET AL., 2004)

FIGURE 6.43 VARIATION OF STRENGTH OF FINE COAL REFUSE WITH FINES CONTENT

6.5.8 Seismic Property Characterization

Laboratory testing for determination of the seismic properties of soil or refuse materials generally involves the evaluation of potential strength loss associated with earthquake loading. This section presents testing methods for: (1) cyclic-triaxial testing, (2) cyclic loading followed by monotonic loading, and (3) resonant-column testing. Chapter 7 presents details of seismic stability and deformation analyses, including the application of the laboratory strain-based approach developed by Castro (1994), sometimes referred to as the residual- or steady-state-strength approach. [Section 7.4.3.2](#) presents guidance for laboratory testing and application of the laboratory tests below.

6.5.8.1 Cyclic-Triaxial Test

The cyclic-triaxial test can be used to evaluate the cyclic strength (or liquefaction potential) of primarily cohesionless, free-draining soils in undrained shear. The samples tested are either undisturbed, or they are reconstituted to simulate the relative density of the in-situ soil. The test apparatus consists of a regular triaxial cell and a cyclic (often sinusoidal) loading machine attached to the loading piston. The sample is isotropically consolidated in the triaxial cell and then subjected to a cyclic axial load in extension and compression. The cyclic loading generally causes an increase in pore-water pressure and a decrease in the effective confining pressure with increasing cyclic deformation of the sample. Failure occurs when the excess pore-water pressure equals the initial effective confining pressure (sometimes called initial liquefaction) or when some limiting cyclic or permanent strain is mobilized. Details regarding the test method are described in ASTM D 5311, "Standard Test Method for Load Controlled Cyclic Triaxial Strength of Soil."

There are limitations to use of cyclic triaxial tests for representing field conditions during earthquake loading, including:

- Non-uniform stress conditions imposed on the test sample by the end platens can cause a redistribution of the void ratio.
- There would be a continuous reorientation of the principal stresses in the field whereas the reorientation angle is either 0 or 90 degrees in the laboratory test.
- The laboratory test sample is isotropically consolidated, whereas the material sampled would be in an at-rest lateral earth pressure (K_0) condition in the field (i.e., lateral stress = K_0 times vertical stress).
- Cyclic shear stress is applied on a horizontal plane in the field but on a 45-degree plane in the triaxial test.
- The mean normal stress in the field is constant while the mean normal stress in the laboratory varies cyclically.

Despite these limitations, the cyclic triaxial test has been used with reasonable success since the early 1960s.

6.5.8.2 Cyclic Loading Followed by Monotonic Loading

The purpose of this type of testing is to evaluate the post-earthquake, residual, steady-state, undrained strength of clay-like materials for post-earthquake stability analyses. A limited number of loading cycles is applied to a test sample to model the straining induced by earthquake loading. Monotonic loading is then applied in order to determine the post-earthquake strength. The initial portion of the test consists of a cyclic triaxial test ([Section 6.5.8.1](#)) followed monotonic loading using the \overline{CU} triaxial test ([Section 6.5.7.4](#)). Selection of the cyclic stress ratio and number of cycles to be applied during cyclic loading depends on requirements discussed in [Section 7.4.3.2](#). Typically, there is a holding period between the end of cyclic loading and the beginning of monotonic loading to permit equilibration of excess pore-water pressures so that measurement of pore-water pressures at

the ends of the sample during \overline{CU} testing are representative of pore-water pressures along the sample shear plane. In reality, the time needed to transition between cyclic and \overline{CU} testing is sufficient to permit pore-water pressure equilibration in the sample. Application of this type of testing program for seismic design is discussed in [Section 7.4.3.2](#).

6.5.8.3 Resonant-Column Test

Evaluation of the response of foundation and embankment soils to seismic ground amplifications requires information regarding shear modulus (G_{max} or G_o) and damping D . While field geophysical methods such as the crosshole, downhole, and surface wave techniques can provide direct in-situ measurements of shear wave velocity ([Section 6.4.4](#)), the resonant-column test permits an evaluation of the variation (decrease) of shear modulus with increasing shear strain γ_s and the increase of D with γ_s under controlled effective stress states. The test may yield lower values than those obtained from field testing due to the effect of soil aging.

The resonant-column test is conducted in accordance with ASTM D 4015, "Standard Test Methods for Modulus and Damping of Soils by the Resonant-Column Method." The undisturbed or reconstituted test specimen is sealed in a flexible membrane and enclosed in a pressure cell similar to that used for triaxial testing ([Section 6.5.7.4](#)). This setup permits the use of back pressure to saturate the test specimen. The resonant-column device excites one end of the test sample in a fundamental mode of vibration by means of torsional or longitudinal motion. Both solid and hollow specimens can be used in the apparatus. Either a sinusoidal torque or a vertical compressional load is applied to the top of the sample through the top cap. The deformation of the top of the sample is measured, and the excitation frequency is adjusted until the sample resonates. The wave velocity or modulus is computed from the resonant frequency and the geometric properties of the sample and driving apparatus. Damping is determined by switching off the current to the driving coil at resonance and recording the amplitude of decay of the vibrations. The decay of the amplitude with time is used to determine the logarithmic decrement (the percentage decay over one log cycle of time), which is directly related to the viscous damping ratio. Typical test results are presented in [Figure 6.44](#). [Figure 6.44a](#) shows the decrease in shear modulus with increasing strain amplitude, and [Figure 6.44b](#) shows the increase in damping with increasing strain amplitude for a clay soil.

The resonant-column test is generally limited to small to intermediate shear strains by the applied force requirements and resonant frequencies. At larger strains, hollow samples must be used to maintain a relatively constant shear strain across the sample. For these reasons, resonant column testing is primarily used to estimate shear modulus associated with small strains.

6.5.9 Rock Property Tests

Common laboratory tests for engineering properties of intact rocks and index testing of rock fragments include measurements of strength, stiffness, and durability. [Table 6.42](#) presents a summary list of ASTM standards and procedures for laboratory rock testing. Additional discussion of the testing of coal is presented in [Section 8.4.2.2](#).

6.5.9.1 Point-Load Index Test

Determination of rock strength is typically determined in the laboratory using specially prepared rock core and specialized test equipment. Because of the extensive sample preparation and equipment requirements, the point-load test was developed so that rock specimens from drilled core, cut blocks or irregular lumps could be tested using portable equipment suitable for the field or laboratory. The point-load test is conducted using an apparatus ([Figure 6.45](#)) that applies a concentrated load through a pair of spherically truncated, conical platens. The distance between the opposing specimen-platen contact points is recorded, and the load is steadily increased until the specimen fractures and the failure load is recorded. The point-load test is conducted in accordance with ASTM D 5731, "Standard Test Method for Determination of the Point Load Strength

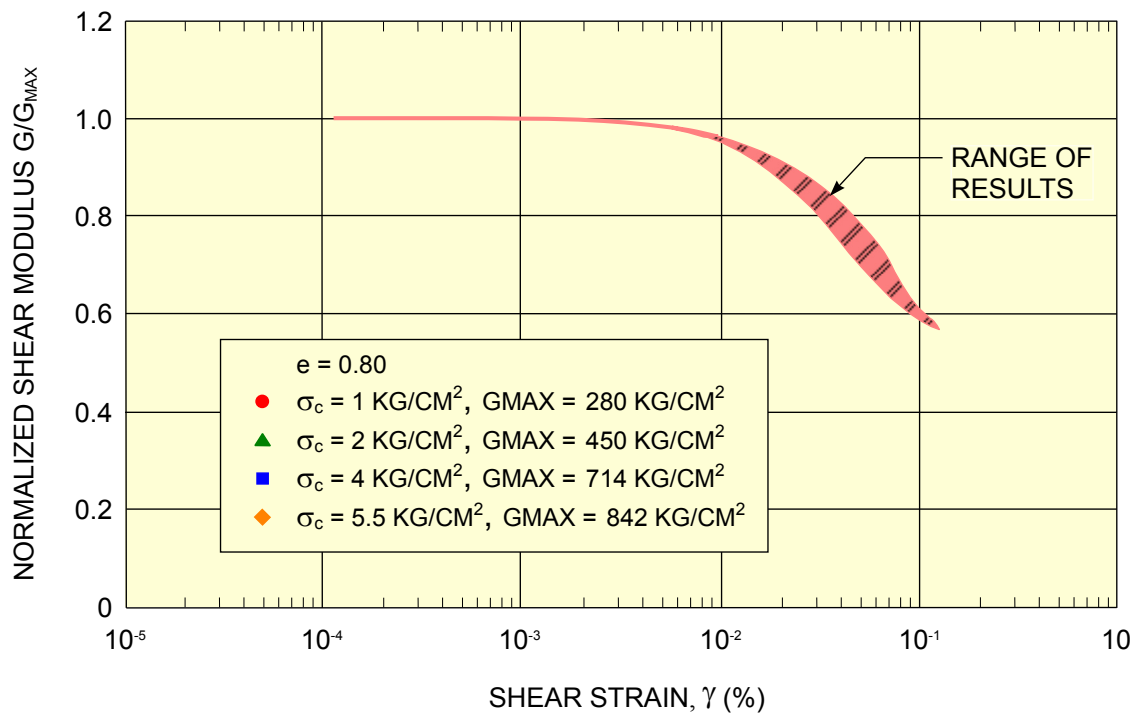

6.44a DECREASE IN SHEAR MODULUS WITH STRAIN

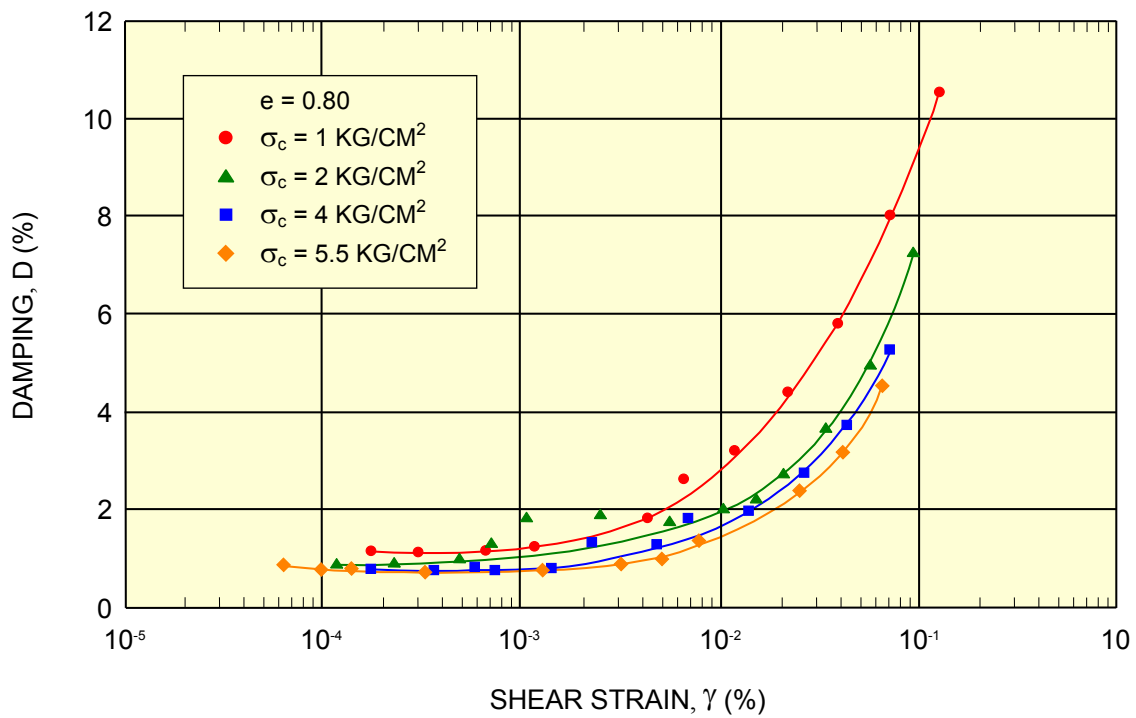

6.44b INCREASE IN DAMPING WITH STRAIN

(ELLISON AND CHO, 1976)

FIGURE 6.44 TYPICAL RESULTS FOR RESONANT COLUMN TEST ON FINE COAL REFUSE

TABLE 6.42 STANDARDS AND PROCEDURES FOR LABORATORY TESTING OF INTACT ROCK

Test Category	Name of Test	ASTM Test Method
Point Load Strength	Standard Test Method for Determination of the Point Load Strength Index of Rock and Application to Rock Strength Classification	D 5731 ⁽¹⁾
Compressive Strength	Standard Test Method for Compressive Strength and Elastic Moduli of Intact Rock Core Specimens under Varying States of Stress and Temperatures	D 7012 ⁽¹⁾
Creep Tests	Standard Test Method for Creep of Rock Core Under Constant Stress and Temperature	D 7070
Tensile Strength	Standard Test Method for Direct Tensile Strength of Intact Rock Core Specimens	D 2936
	Standard Test Method for Splitting Tensile Strength of Intact Rock Core Specimens	D 3967 ⁽¹⁾
Direct Shear	Standard Test Method for Performing Laboratory Direct Shear Strength Tests of Rock Specimens under Constant Normal Force	D 5607 ⁽¹⁾
Hydraulic Cond.	Standard Test Method for Permeability of Rocks by Flowing Air	D 4525
Durability	Standard Test Method for Slake Durability of Shales and Similar Weak Rocks	D 4644 ⁽¹⁾
	Standard Test Method for Testing Rock Slabs to Evaluate Soundness of Riprap by Use of Sodium Sulfate or Magnesium Sulfate	D 5240
	Standard Test Method for Evaluation of Durability of Rock for Erosion Control under Freezing and Thawing Conditions	D 5312
	Standard Test Method for Evaluation of Durability of Rock for Erosion Control under Wetting and Drying Conditions	D 5313
Deformation and Stiffness	Standard Test Method for Compressive Strength and Elastic Moduli of Intact Rock Core Specimens under Varying States of Stress and Temperatures	D 7012
	Standard Test Method for Laboratory Determination of Pulse Velocities and Ultrasonic Elastic Constants of Rock	D 2845
Specimen Preparation	Standard Practices for Preparing Rock Core as Cylindrical Test Specimens and Verifying Conformance to Dimensional and Shape Tolerances	D 4543
	Standard Practice for Preparation of Rock Slabs for Durability Testing	D 5121

Note: 1. The rock test procedure associated with this ASTM standard is described in the Chapter 6 text. Additional discussion of the testing of coal is presented in Section 8.4.2.2.

(ADAPTED FROM MAYNE ET AL., 2002)

Index of Rock.” The test is used to classify and characterize rock that has a compressive strength greater than 2,200 psi.

ASTM recommends that test samples conform to size and shape requirements. In general, for diametral tests, core specimens with a length-to-diameter ratio of 1.0 are adequate, while for axial tests, core specimens with length-to-diameter ratio of 0.3 to 1.0 are suitable. Specimens for the block and the irregular lump test should have a length of 50 ± 35 mm and a length-to-width ratio between 0.3 and 1.0 (preferably close to 1.0). Samples are typically tested at their natural moisture content.

Size corrections are applied to obtain the point-load strength index $I_{S(50)}$ of a rock specimen. A strength anisotropy index $I_{a(50)}$ is determined when $I_{S(50)}$ values are measured perpendicular and parallel to

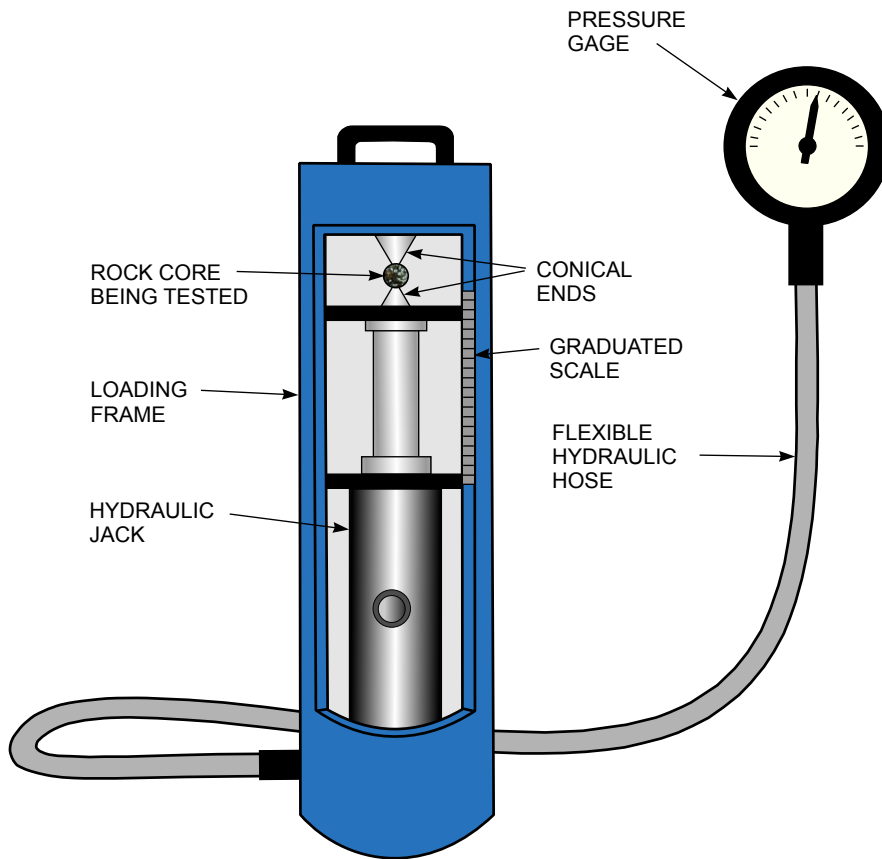

(ADAPTED FROM MAYNE ET AL., 2002)

FIGURE 6.45 POINT-LOAD TEST APPARATUS

planes of weakness. The test can be performed in the field or in the laboratory. The point-load index is used to estimate the unconfined compressive strength q_u using a relationship of the form:

$$q_u = K I_{s(50)} \quad (6-14)$$

The value of the constant K has been reported to vary from 15 to 50 (especially for anisotropic rocks) depending upon the specific rock formation. Rusnak and Mark (2000) determined that $K \approx 21$ for rocks associated with coal seams in the eastern, mid-western and western U.S. Additional discussion of the limitations of testing of coal is presented in [Section 8.4.2.2](#).

6.5.9.2 Unconfined Compressive Strength Test

The unconfined compressive strength serves as an initial index of the competency of intact rock and represents the most direct method for determining rock strength. The test method is described in ASTM D 7012, "Standard Test Method for Compressive Strength and Elastic Moduli of Intact Rock Core Specimens under Varying States of Stress and Temperatures." In this test, cylindrical rock specimens are tested in compression without lateral confinement. The test procedure is similar to the unconfined compression test for soils and concrete. The test specimen should be a rock cylinder of length-to-width ratio in the range of 2 to 2.5 and should have flat, smooth, and parallel ends cut perpendicular to the cylinder axis in accordance with ASTM D 4543, "Standard Practices for Preparing Rock Core Specimens and Determining Dimensional and Shape Tolerances." The peak stress during unconfined loading is the uniaxial compressive strength q_u . The results may be affected by: (1) moisture content, (2) rate of loading, (3) condition of both ends of the rock sample, and (4) the presence of

inclined fissures, intrusions, and other anomalies that may cause premature failures on the associated planes. These conditions should be noted so that other tests such as triaxial or direct shear tests can be performed, as appropriate. Because the tests are of necessity conducted using intact rock samples, the test results may not be representative of rock mass behavior due to the effects of in-situ discontinuities (e.g., bedding planes and joints), weathering and moisture. For these reasons, unconfined compressive strength testing should be limited to rock types and strata where tests on intact rock are reasonably representative of the rock mass. This is especially a problem in determining the compressive strength of coal through laboratory testing of small-diameter core (e.g., 2 to 3 inches) because the presence of defects in the coal results in unconservative strengths as compared to the strengths determined from tests on larger-diameter core (e.g., 6 to 12 inches) and in-situ tests on field-scale test volumes (Pariseau, 2006). Additional discussion of the limitations of testing of coal is presented in [Section 8.4.2.2](#).

The stress-strain behavior of intact rock samples can be measured during an unconfined-compression test in accordance with ASTM D 7012, "Standard Test Method for Compressive Strength and Elastic Moduli of Intact Rock Core Specimens under Varying States of Stress and Temperatures." For this test, specimen deformations are measured using strain gauges applied to the test specimen or linear voltage displacement transducers attached to the top and bottom load platens.

6.5.9.3 Indirect Tensile Strength Test

Rock is relatively weak in tension; thus, the tensile strength T_o of intact rock is approximately 5 percent of its compressive value (Mayne et al., 2002). Because of the difficulties involved in proper end preparation (Jaeger et al., 2007), the direct tensile strength testing of rock specimens is not a common laboratory procedure. Therefore, the tensile strength of rock is usually determined by indirect methods such as the indirect tensile (Brazilian) test. The indirect tensile strength of intact rock core σ_T is determined in accordance with ASTM D 3967, "Standard Test Method for Splitting Tensile Strength of Intact Rock Core Specimens." Core specimens with length-to-diameter ratios between 2 and 2.5 are placed in a compression loading machine with the load platens placed diametrically across the specimen. The maximum load to fracture the specimen is recorded and used to calculate the indirect tensile strength.

Alternatives to the indirect tensile strength test are the direct tensile strength test and the bending test. The direct tensile strength of intact rock core is determined in accordance with ASTM D 2936, "Standard Test Method for Direct Tensile Strength of Intact Rock Core Specimens." The core specimens for direct tensile testing are prepared as described in ASTM D 4543 for compressive strength testing, but the test is conducted by cementing the specimen ends to the test load apparatus and applying tensile loads on the sample until it fails in tension. While there is no ASTM standard for bending tests, the test specimens need to be long relative to their thickness which makes their preparation difficult and expensive, especially when samples are taken from very jointed rock strata (Pariseau, 2006).

Thus, the indirect tensile strength test is significantly more convenient and practical for routine measurements than the direct tensile strength test and the bending test, and it provides very similar results to those obtained from direct tension tests (Jaeger et al., 2007). In many situations, the indirect tensile test provides a more fundamental measurement of rock material strength than compression tests because the failure mode is more representative of failures that occur (e.g., overstressing of roof strata) in underground mines. It should be noted that the point-load index test discussed in [Section 6.5.9.1](#) is actually a variation of the indirect tensile strength test with results correlated to compressive strength.

6.5.9.4 Rock Durability

Rock used for slope protection and aggregate used for drainage purposes must have high durability to attain suitable long-term performance when exposed to construction and in-service environments.

Material deterioration mechanisms include cracking, spalling, delaminating or splitting, disaggregating, dissolving and disintegration (USACE, 1990a). The following ASTM test methods can be used to evaluate the durability of these types of materials:

- D 5240, "Rock Slab Testing For Riprap Soundness, Using Sodium/Magnesium Sulfate"
- D 5312, "Rock-Durability For Erosion Control Under Freezing/Thawing"
- D 5313, "Rock-Durability For Erosion Control Under Wetting/Drying"

Additional rock durability test methods that have been used for evaluation of the slake durability of surface mine spoils and earthen embankments constructed using shale and other slake prone sedimentary rocks are described in Andrews et al. (1980) and Michael and Superfesky (2007). Some of these test methods involve use of acid solutions.

Rock materials used for constructing earthen dam and coal refuse embankments are generally obtained from borrow sources near the construction area. Because coal is found in geologic settings where shales and other weak rocks are encountered as part of mining operations, the durability of these rock materials as compacted fill needs to be evaluated. The most problematic rock types are certain shales, mudstones, claystones and other weak rocks that degrade rapidly soon after they are exposed to atmospheric conditions. These materials can degrade rapidly, affecting the stability of an embankment fill, a rock cut, or foundation on which a refuse embankment is constructed.

The slake durability test was devised in the early 1970s (Franklin and Chandra, 1972) to provide a qualitative measure of these materials in service. As described in ASTM D 4644, "Standard Test Method for Slake Durability of Shales and Similar Weak Rocks," representative rock fragments are subjected to cycles of wetting and drying, and the weight loss is measured after two cycles. Figure 6.46 provides an illustration of the slake durability test apparatus.

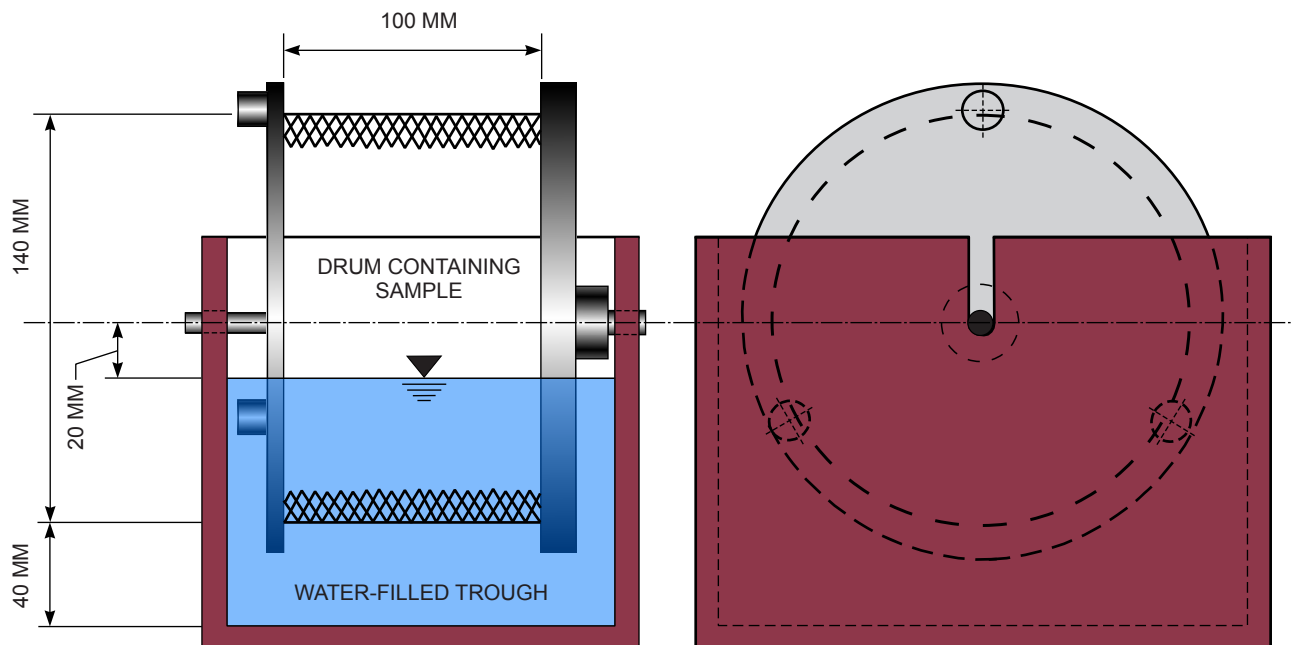

(MAYNE ET AL., 2002)

FIGURE 6.46 ROTATING DRUM ASSEMBLY AND SETUP OF SLAKE DURABILITY EQUIPMENT

Ten dried fragments of rock of known weight are placed in a drum fabricated with 2.0-mm-square mesh wire cloth. The drum is rotated in a horizontal position along its longitudinal axis while partially submerged in distilled water to promote wetting of the sample. The specimens and the drum are dried at the end of the rotation cycle (10 minutes at 20 rpm) and weighed. After two cycles of rotating and drying, the weight loss and the shape and size of the remaining rock fragments are recorded, and the slake-durability index (SDI) is calculated. As a qualitative measure of durability, Gamble (1971) proposed the classification system presented in [Table 6.43](#) using the SDI determined after two cycles. Both the SDI and the description of the shape and size of the remaining particles are used to determine the durability of soft rocks. The application of the test for design and construction with mine spoil is presented in [Section 8.8.2](#).

Limestone and calcite cemented sandstone can degrade relatively quickly where acidic leachates are present and should not be used in the construction of filters, underdrains and internal drains. A fizz test of aggregate and rock can be conducted by placing a dilute solution of hydrochloric acid on the material. If an effervescent or fizzing reaction occurs, the material is generally considered to be unacceptable. Laboratory testing may also be performed on aggregate materials to evaluate the calcium-carbonate portion in terms of percent of total content. The presence of sulfide minerals in aggregates can lead to the formation of sulfuric acid and sulfate minerals and should also be avoided. Generally, aggregate materials should contain less than 1 to 5 percent calcium carbonate and much less than 1 percent sulfide materials in order to be acceptable for drain applications.

6.5.10 Structural Material Tests

This section identifies the quality control tests that should be considered in developing plans and specifications for disposal facilities when using portland cement concrete and controlled low-strength material (CLSM).

6.5.10.1 Concrete

Portland-cement concrete is used at coal refuse disposal facilities for construction of drainage control structures and structure foundations. Structural design of reinforced concrete is beyond the scope of this Manual. For additional guidance, the most current version of ACI 318, "Building Code Requirements for Structural Concrete and Commentary," should be used. [Table 6.44](#) presents ASTM test methods for quality control of fresh portland-cement concrete.

6.5.10.2 Controlled Low-Strength Materials (CLSM)

CLSM is used as a replacement for compacted earth fill and consists of various mixtures of pozzolan (e.g., fly ash), portland cement, aggregates (typically fine aggregate such as sand and/or bottom ash), select cohesionless soil, water, and occasionally chemical admixtures (Howard and Hitch, 1998). A low percentage of bentonite or attapulgite can also be included in CLSM for reduced hydraulic conductivity and enhanced plasticity, where such characteristics are important. CLSM has been used for general backfills, shallow cutoff trenches, structural fills, insulating and isolating fills, pavement bases, erosion control, pipe bedding, cradles and backfill, and void filling. It is the latter two applications that have found the greatest application in mining and mine refuse disposal. CLSM is processed and mixed much like fresh concrete and delivered as a fluid in ready-mix trucks or as a dry material in a dump truck. The quality control test methods used for CLSM are adapted from those used for fresh concrete and grout, accounting for the various constituents in the CLSM mix and its lower compressive strength (i.e., 1,200 psi or less). [Table 6.45](#) presents test methods used for quality control of CLSM.

CLSM must be designed in accordance with performance criteria appropriate for the specific application. At coal refuse disposal facilities, CLSM is used primarily for bedding and backfilling of pipe. When pipe is used as part of a decant or other structure that extends through the embankment cross section, the bedding and backfill should have adequate strength to provide support for the pipe and

TABLE 6.43 SLAKE DURABILITY CLASSIFICATION

Durability Classification	Percent Retained after Two 10-Minute Cycles
Very High	> 98
High	95 to 98
Medium High	85 to 95
Medium	60 to 85
Low	30 to 60
Very Low	< 30

(GAMBLE, 1971)

TABLE 6.44 QUALITY CONTROL STANDARDS FOR PORTLAND-CEMENT CONCRETE

Description	ASTM Test Method
Standard Test Method for Compressive Strength of Cylindrical Concrete Specimens	C 39
Standard Test Method for Slump of Hydraulic Cement Concrete	C 143
Standard Test Method for Air Content of Freshly Mixed Concrete by the Volumetric Method	C 173
Standard Test Method for Air Content of Freshly Mixed Concrete by the Pressure Method	C 231

low hydraulic conductivity and suitable stiffness and shrinkage characteristics to limit the potential for seepage along the pipe. The bedding should also perform as intended relative to the desired pipe behavior (i.e., flexible versus rigid system). Typical CLSM mix designs have a target maximum compressive strength in the range of 50 to 200 psi for flexible pipe installations and up to 1,200 psi for structural applications. When CLSM is used in flexible pipe installations, a lower strength CLSM is specified in order to produce high quality, soil-like bedding, cradle, and backfill zones to preserve the flexible behavior of the pipe-backfill system while capitalizing on the benefits of CLSM (i.e., ease of placement, better protection of the pipe under construction traffic loadings, improved haunch support and seepage control due to more intimate contact with the pipe, resistance to piping and erosion, and better quality control). Testing of the uniaxial strength of CLSM samples for design of flexible pipe installations should follow ASTM C109 with the addition of strain measurements for determination of the modulus of elasticity in accordance with ASTM D7012. [Table 6.46](#) provides a mix design guide for CLSM. It should be noted that the CLSM strength is also dependent on the cement, ash and mixing water characteristics. Application-specific design and testing is recommended for use of CLSM as pipe backfill, with strengths evaluated at 7, 14 and 28 days (similar to concrete) and also at 56 and 90 days.

TABLE 6.45 QUALITY CONTROL STANDARDS FOR CLSM

Description	ASTM Test Method
Standard Test Method for Preparation and Testing of Controlled Low Strength Material (CLSM) Test Cylinders	D 4832
Standard Practice for Sampling Freshly Mixed Controlled Low-Strength Material	D 5971
Standard Test Method for Unit Weight, Yield, Cement Content, and Air Content (Gravimetric) of Controlled Low Strength Material (CLSM)	D 6023
Standard Test Method for Flow Consistency of Controlled Low Strength Material (CLSM)	D 6103

TABLE 6.46 CLSM MIX DESIGN GUIDE

Properties and Criteria	Type A	Type B	Type C	Type D
<u>Mix Design</u> ⁽¹⁾ (per yd ³)				
Cement (lb)	100	50	150 to 200	300 to 700
Pozzolans (lb)	2000	300	300	100 to 400
Bottom ash or coarse aggregate or fine aggregate (lb)	0	2600	2600	(2)
Air entrainment				
Slump (in) – ASTM C 143	7 (min.)	7 (min.)	7 (min.)	7 (min.)
Density (lb/ft ³) – ASTM D 6023	NA ⁽³⁾	NA	NA	30 to 70 or as specified ⁽⁴⁾
Water absorption of aggregate – AASHTO T 85	–	–	–	20% max.
Compressive strength (psi)	125 (max.)	125 (max.)	800 (max.)	90 to 400

- Note: 1. Quantities may vary in order to adapt mix to density and strength requirements or to adapt to site conditions and material characteristics.
 2. Requires use of suitable light-weight aggregate or air-entraining admixture.
 3. Not applicable.
 4. Approximate value; use of air-entraining agent may reduce this value.

(ADAPTED FROM PennDOT, 2007)

6.5.11 Verification of Test Results

Unverified or unvalidated test data or engineering properties (e.g., parameters that are assumed from published or other available sources or adopted from other sites without evaluation of their appropriateness) should not be used in the design of refuse disposal facilities. The only exceptions are analyses for facilities with very simple embankments with low hazard potential and for embankments where very conservative slopes are acceptable. Therefore, it is important to verify test data, particularly those for shear strength.

If site access, time and budget were not an issue, the design engineer could obtain as many samples as deemed necessary and conduct as many laboratory or in-situ tests as desired to obtain a complete assessment of subsurface soil and rock conditions. Engineering properties would be quantified, and any inconsistent data would be set aside and additional testing would be initiated, as needed. Unfortunately, site access, schedule and budgets are major factors that designers must consider in making critical decisions throughout the design process to obtain the most reliable and realistic soil, rock and coal refuse property data. As described previously, a critical step in determining these properties lies in the selection of specific tests and proper interpretation of the test results. For a number of reasons (e.g., cost, sampling difficulties or lack of representative values), it may be difficult to determine values for specific parameters of interest. Fortunately, designers can sometimes use established and/or site-specific correlations to obtain values for the desired parameters. Correlations are useful for evaluating test results that do not appear to be representative, and they can also be very useful in preparing test programs, performing preliminary calculations, and serving as a quality assurance check on the test results.

Engineering property correlations come in many forms, but all have a common theme. Specifically, a useful correlation is developed from a large database of results based on past experience. In the best case, the correlation and experience have been developed or “calibrated” using specific site construction materials, or the correlation may be based on reportedly similar construction materials. The reliance upon or use of correlations to obtain soil, rock and coal refuse properties may be justified

in the following cases: (1) specific data are simply not available and the only possibility is indirect comparison to other properties, (2) a limited amount of data for the specific property of interest are available and the correlation will complement these limited data, or (3) the validity of certain data is in question and a comparison to previous test results allows the accuracy of the data to be evaluated. It is strongly emphasized that correlations should never be used as a substitute for an adequate site exploration program, but rather should complement and verify available test data. Examples of each of the three cases listed above are provided in the following:

- Specific data are unavailable – Several examples of this type exist. Most notable is the strength of uncemented clean sands. Undisturbed sampling may be problematic and prohibitively expensive, and correlations to SPT, CPT, and other in-situ tests results have been shown to be quite reliable.
- Limited data are available – If few high-quality consolidation tests are performed and compression properties are found to correlate well with the results of Atterberg limits tests, it may be concluded that Atterberg limits tests can be used for assessment of compression properties.
- Data validation – If results from tests on two similar materials are inconsistent, comparing the results to previous data for similar soils may allow determination as to whether the data are simply inconsistent or if some of the data are inaccurate.

There are several sources of correlation data for geotechnical materials and properties. Many geotechnical textbooks and references provide correlations, including Holtz and Kovacs (1981), DOD (2005) and Carter and Bentley (1991). The Electric Power Research Institute (EPRI) commissioned the preparation of useful documents that include several correlations for laboratory and in-situ tests (Kulhawy and Mayne, 1970). For information regarding the engineering properties of coal refuse materials, designers should refer to Hegazy et al. (2004), Chen (1979), DiGioia and Gray (1979), and Coates and Yu (1977).

The following comments on applicability and use of correlations are noted:

- A correlation is only as good as the data upon which it is based.
- There may be some scatter in the correlation data. The effects of data scatter should be accounted for by using upper and lower bound (i.e., best case/worst case) scenarios and factors of safety in the design calculations.
- A correlation will be most accurate if it is calibrated to site soil/material conditions.
- If calibration to site conditions and design-phase laboratory test data cannot be conducted in sufficient detail, consideration should be given to an expanded program of field inspection, performance monitoring and maintenance (Chapter 12) and instrumentation (Chapter 13).

6.6 GEOTECHNICAL ANALYSES

Sections 6.1 through 6.5 have addressed planning and design considerations, site exploration, and material property characterization required for development of a functional, safe and environmentally acceptable coal refuse disposal facility. This section discusses geotechnical analyses associated with refuse disposal facility design. Analytical procedures for seepage, settlement, slope stability, rock excavation, and conduit design are presented. These discussions are necessarily limited in both scope and depth. More extensive treatments of these subjects are available in references cited herein.

6.6.1 Analytical and Numerical Methods in Geotechnical Engineering

Many of the important areas of geotechnical engineering analysis are governed by differential equations for solving problems of elastic equilibrium, consolidation and steady-state seepage.

Limit analysis using classical techniques such as Rankine's earth pressure theory, Terzaghi's bearing capacity equation, or various methods of slices is another important approach for the solution of geotechnical problems involving the failure of soil masses for slope stability analysis. These "traditional" methods of analysis, as applied to the design of coal refuse disposal facilities, are discussed in the following text. Seismic analysis and design issues for refuse disposal facilities are addressed in Chapter 7.

The availability of powerful personal computers, augmented by improved tools for problem setup, constitutive modeling of material properties, and post-processing of computational results, has facilitated the use of numerical methods to solve complex geotechnical problems. Sophisticated methods, such as the finite element (FE) method, are available to perform complex analyses related to seepage, deformation, and slope stability. The FE method is a numerical method for obtaining solutions to differential equations, given appropriate boundary condition data. Some of the most useful features of the FE method are that it can:

- Simulate one-, two- and three-dimensional problems
- Accommodate complex geometries and construction sequencing
- Model soil property variability (e.g., nonlinear stress-strain behavior and anisotropic hydraulic conductivity)

Nearly all areas of geotechnical analysis can be solved using the FE method. However, the engineer must recognize the inherent uncertainty and variability in material properties. The possible effects of simplifying assumptions for material behavior in FE models must be carefully evaluated. An understanding of empirical relationships and the ability to apply the lessons of experience are key factors in successfully using FE models and interpreting the results obtained.

6.6.2 Seepage Analysis

6.6.2.1 Basic Assumptions, Conditions Requiring Seepage Analysis

All earth and coal refuse structures are to some degree pervious to water and therefore susceptible to seepage. Seepage is a concern in earthen dams and coal refuse embankments for three reasons: (1) the pore-water pressures in an embankment and its foundation affect the stability of the embankment, (2) an excessive hydraulic gradient on an embankment slope, at drain or fine/coarse material interfaces, or at the toe can lead to piping, internal erosion, and destructive uplift pressures, and (3) water lost through or under a structure may require treatment or may be a valuable water source worth recirculating through the preparation plant. Seepage control systems are incorporated into embankments to minimize the potential for excessive or uncontrolled seepage. Practical concepts for seepage control in coal refuse embankments and their foundations are discussed in Section 6.3. This section discusses analytical methods for assessing the need for seepage control and for selecting materials and design dimensions to achieve that control. Additionally, operational controls to mitigate seepage, such as the deposition of slurry within impoundments, are also discussed.

Under steady-state conditions, seepage through an earth or coal refuse embankment and its foundation can be estimated from the relationship for flow through porous media, which is based on the following assumptions:

- The flow occurs through incompressible media.
- The flow is caused by gravity forces only.
- The media through which flow occurs is always saturated.
- The boundary conditions of the flow are known.

For unsaturated flow and transient seepage analyses, additional assumptions may be required.

Whether or not the boundary conditions are actually known depends on the specific flow condition being analyzed. For flow through a pervious foundation under a relatively impervious embankment, the boundary conditions are readily apparent. However, not all boundary conditions are easily determined, and many boundary conditions must be approximated or determined by iterative analysis procedures (e.g., the seepage and phreatic condition in an embankment with internal drains).

Steady-state flow through porous media such as soils or coal refuse is normally laminar and therefore follows the Darcy equation:

$$Q = k i a \quad (6-15)$$

where:

- Q = flow rate (volume/time)
- k = coefficient of hydraulic conductivity (length/time)
- i = hydraulic gradient (dimensionless)
- a = cross-sectional area through which flow occurs (area)

Selection of the coefficient of hydraulic conductivity should be based on field and laboratory testing, although evaluation of other factors may also be required, including:

- Published information (e.g., soil surveys) along with the results of site-specific index and classification tests for natural soils and coal refuse.
- Potential variability of existing fill or mine spoil, especially when there are no available data related to in-situ material or placement.
- Potential for anisotropic conditions (if not documented based upon site-specific data), particularly for coal refuse embankments where the horizontal hydraulic conductivity may be an order of magnitude greater than the vertical hydraulic conductivity.
- Sensitivity of flow rate and hydraulic gradient (and phreatic surface) to variation of assumed parameters.
- Observed site groundwater levels in natural soils and existing embankments (to assist in validating assumed values, particularly if multiple zones or anisotropic conditions are present).

Seepage analysis for coal refuse embankments should be based on conservative estimates of hydraulic conductivity, with values selected based on available test data (preferably field tests), material classifications and anisotropy ratios resulting in conservative (higher) phreatic levels and seepage rates. The ratio of horizontal to vertical hydraulic conductivity (anisotropy ratio) can vary due to the material type, placement and compaction in lifts, and for embankment dams has been reported to range from 1 to 100 (Fell et al., 2005). The U.S. Army Corps of Engineers (USACE, 1993) suggests an anisotropy ratio between 2 and 10 or greater for embankment dams constructed in compacted lifts, and MSHA (2007) recommends a ratio of at least 9 for coarse coal refuse or as based upon site-specific conditions and materials. For an existing embankment, back calculation of monitored pool and piezometer levels to estimate anisotropy is recommended.

If fine coal refuse deposits are accounted for in the seepage analysis, an anisotropy ratio of between 1 and 10 is usually applied. In typical situations where coarse coal refuse is more permeable than

the fine refuse, the anisotropy ratio of the fine refuse deposit may have little effect on the computed phreatic levels and seepage rates in downstream coarse refuse embankments. It is likely that the anisotropy ratio of hydraulically-placed fine refuse is quite variable (beyond the range cited above) such that design of seepage control and collection measures critical for stability of the facility should be effective over the likely range of anisotropy.

For impounding coal refuse embankments, seepage analyses should be performed for critical intermediate stages along with the final stage of development. The pool level used in the seepage analysis should be the maximum normal pool level for the stage (usually based on the decant invert level) or, if there is potential for saturation of the embankment due to retention of the design storm, the maximum design storm pool level.

Unsteady-state seepage analysis can be employed for evaluation of the extent of saturation of an embankment or to assess the impact of rapid drawdown on the upstream embankment slope. Also, unsaturated flow analysis is sometimes coupled with saturated flow analysis (generally using numerical models) to evaluate internal drainage systems, particularly where there is significant anisotropy.

Turbulent flow regimes may occur in rockfill and rock drains used in embankments. Based on earlier work by Cedergren (1989), the U.S. Army Corps of Engineers (1993) provides guidance for estimating the reduction in hydraulic conductivity of narrow size range aggregate caused by turbulent flow at large hydraulic gradients in underdrains (Figure 6.47). As indicated in Cedergren (1989), the reduction in hydraulic conductivity is of relatively little importance for flat-lying underdrains if hydraulic gradients are less than 0.02. Furthermore, the effect of increasing the hydraulic gradient 100 times (from 0.01 to 1.0) reduces the hydraulic conductivity to one-tenth of the laminar value. Alternatively, Leps (1973) developed the following empirical relationship for turbulent flow through rock which is sometimes applied:

$$Q = a W m^{0.5} i^{0.54} [e / (1 + e)] \tag{6-16}$$

where:

- Q = flow rate (length³/time)
- a = flow cross section area (length²)
- W = empirical constant for rockfill material, dependent on the shape and roughness of rock particles and the viscosity of water (length-time units) (Wilkins, 1956)
- m = hydraulic mean radius (length)
- i = hydraulic gradient (dimensionless)
- e = void ratio (dimensionless)

Leps (1973) provides the following guidance on the determination of $Wm^{0.5}$ based on rock size:

Rock size (in)	3/4	2	6	8	24	48
$Wm^{0.5}$ (in/sec)	10	16	28	32	58	84

While Equation 6-16 applies to uniformly-sized rock, Leps suggests that it can be adapted for graded materials by using the 50-percent rock size to compute $Wm^{0.5}$, provided that the minus 1-inch material is less than 30 percent, and preferably less than 10 percent by weight, of the rockfill. If the percentage of minus 1-inch material is greater than 30, Equation 6-16 may not be applicable.

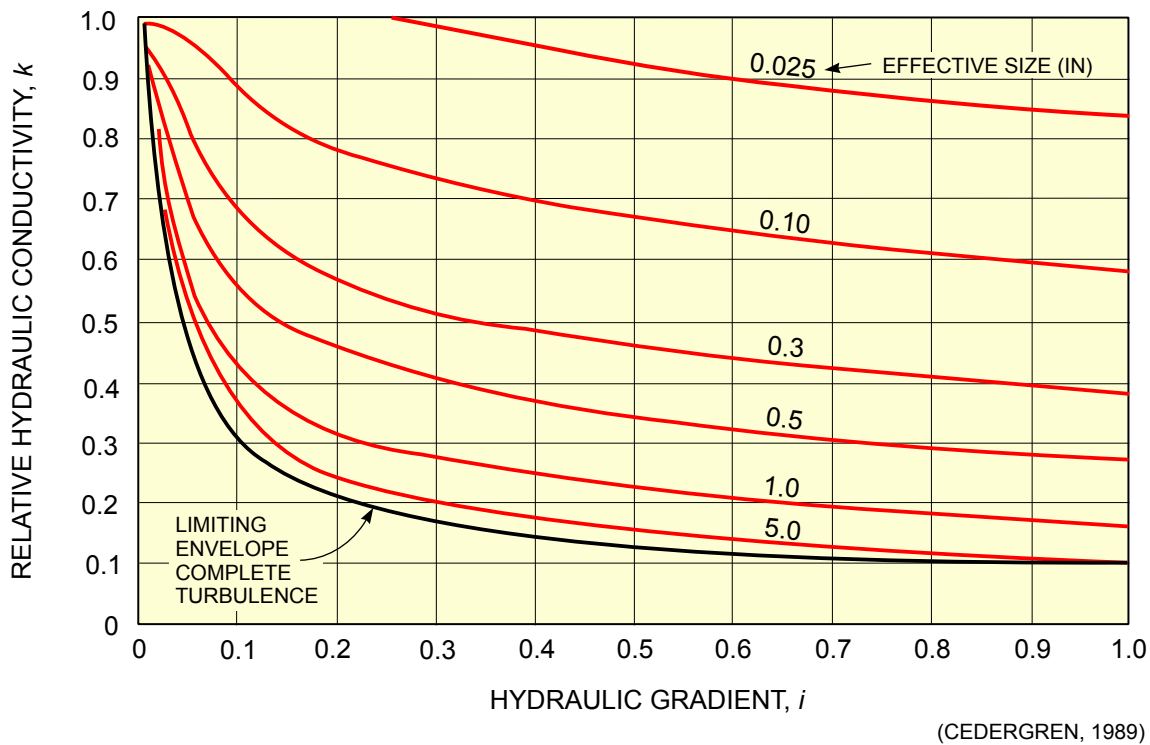

FIGURE 6.47 APPROXIMATION FOR ESTIMATED REDUCTION IN HYDRAULIC CONDUCTIVITY UNDER TRUBULENT FLOW

6.6.2.2 Seepage Analysis Methods

There are several approaches for conducting seepage analyses. Prior to the widespread availability of computers, graphical hand-solutions (i.e., hand-drawn flow nets) and hand calculations were commonly used for modeling embankment and foundation seepage. However, the use of numerical methods (primarily finite element modeling) has become the most common method for seepage analyses. These approaches are discussed in the following sections.

Seepage in homogeneous coal refuse embankments can be readily analyzed using graphical and analytical methods, provided that the hydraulic conductivity and any anisotropy are known. Zoned embankments, variable foundation conditions, and the presence of the settled fine coal refuse introduce additional complexity, and numerical methods are better suited for detailed analysis of these situations. Coal refuse embankments are developed in stages, each with a specific configuration and internal drainage system designed on the basis of the projected fine coal refuse level and pool level. Thus, in addition to the final impounding stage, intermediate stages will likely need to be analyzed as part of the design of internal drainage structures and to establish the stage configuration in conjunction with the stability analysis.

With either the graphical, analytical or numerical modeling approach, it is essential that the boundary conditions for the analysis be accurately defined. These boundary conditions typically include:

- Appropriate reservoir/impoundment pool level
- Foundation conditions, including possible artesian conditions
- Location(s) and capacity(s) of internal drains
- Geometry of intermediate and post-construction cross sections
- Maximum and minimum potential inflow rate(s) to the reservoir/impoundment

Selection of the appropriate elevations for water and fine coal refuse in an impoundment are important if meaningful results are to be realized. Typically, normal pool or the maximum decant inlet level for a specific stage is selected. If the reservoir pool is above the settled fine coal refuse level and against the upstream slope of the impoundment, the effect on the phreatic surface elevation of the fine coal refuse will be limited, even if it has low hydraulic conductivity relative to the coarse refuse. If the impoundment is designed to retain a design storm that would cause saturation of the embankment due to an elevated reservoir level, then seepage associated with that reservoir level should be analyzed. Cedergren (1989) provides a method for estimating the approximate time for embankment saturation to occur for simple embankment geometry and homogeneous hydraulic conductivity. Unsteady seepage analyses can be performed for complicated geometries and zoned embankments, although it is recommended that the designer exercise caution and consider redundant seepage control measures in critical situations.

Site conditions may necessitate the evaluation of other features and boundary conditions. As one of the primary purposes of seepage analyses is to determine seepage conditions for use in stability analyses, the locations of the seepage cross sections should be consistent with the locations of stability sections (for 2D analyses). Also, the size, lateral extent and continuity of drainage features should be evaluated when deciding whether and how to incorporate them into the analysis. For example, a blanket drain that is limited in lateral extent to the center of a valley may not significantly affect the phreatic level at the abutments of an embankment. In such a case, it may be necessary to also analyze the influence of a higher saturation level in cross sections close to the abutments.

6.6.2.2.1 Graphical (Flow Net) Approach

A flow net is a set of orthogonal lines graphically representing the seepage conditions in an embankment. The seepage at any cross section of an earth or coal refuse embankment can be determined by constructing a flow net using free-hand trial-and-error sketching. One group of flow net lines represents paths of flowing water, and the other group represents lines of equal head (equipotential lines). The flow net must satisfy the flow boundary conditions. The flow lines and equipotential lines must intersect at right angles, and for each element the mean dimension parallel to the flow lines must equal the mean dimension parallel to the equipotential lines (or remain in the same proportion over the extent of the flow net). These dimensional requirements can be checked by drawing a circle in elements and determining if it is tangent to the mid-sides of the adjacent flow and equipotential lines. Figure 6.48 shows a typical flow net analysis.

To estimate the rate of seepage flow from a two-dimensional flow net of unit thickness, the Darcy equation can be written in the following form:

$$q = k h (N_f/N_d) \quad (6-17)$$

where:

- q = flow rate per unit width (length²/time)
- k = coefficient of hydraulic conductivity (length/time)
- h = total head loss across the system (length)
- N_f = number of flowpaths through the system (dimensionless)
- N_d = number of potential drop (divisions of head loss) across the system (dimensionless)

Examples of the application of this equation are provided in numerous references, including Cedergren (1989), Harr (1962) and USACE (1993).

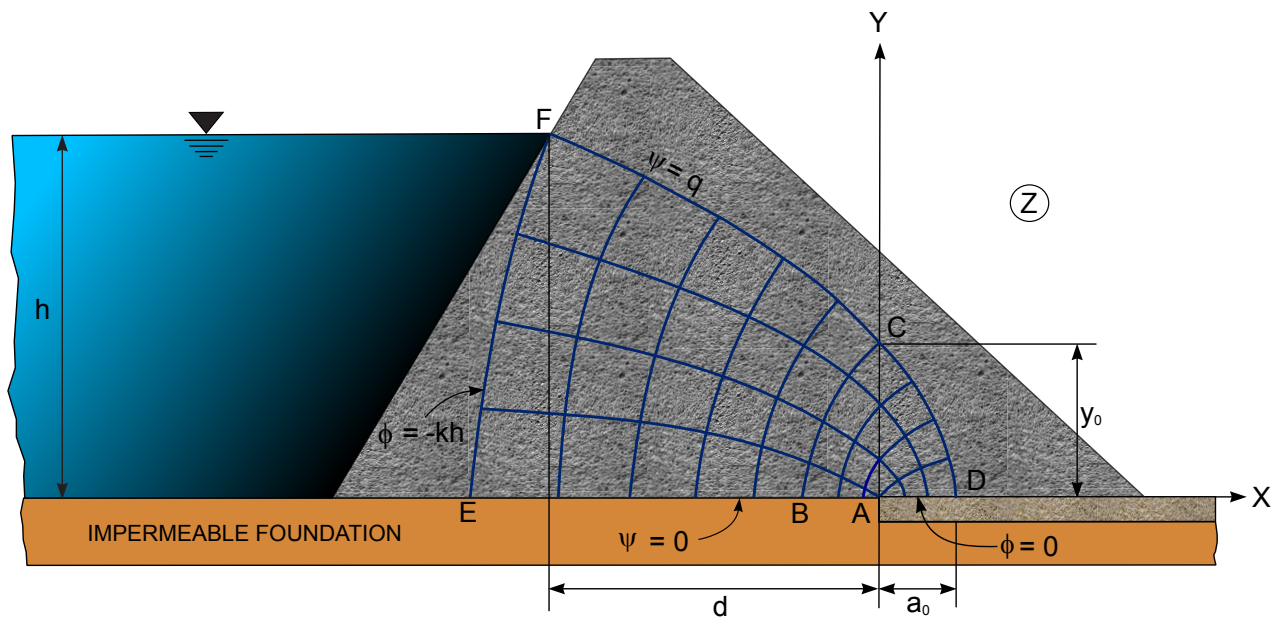

(HARR, 1962)

FIGURE 6.48 FLOW NET ANALYSIS

An example of the flow net graphical approach is illustrated in [Figure 6.49a](#) for a homogeneous dam section. [Figure 6.49b](#) illustrates the graphical transformations necessary to develop flow nets for a homogeneous dam embankment with anisotropic hydraulic conductivity. When a dam is composed of a number of different soils with varying anisotropic hydraulic conductivity, the graphical approach becomes considerably more complicated. In practice, the use of graphical methods may require that a number of simplifying assumptions be made to render the problem manageable. The construction of flow nets and their application are described in USDA (1973a) and Reddi (2003).

6.6.2.2 Analytical Solutions

The seepage and associated phreatic surface for an embankment dam with an underdrain resting on an impervious base, generally referred to as Kozeny's basic parabola, can be determined analytically (Harr, 1962). The phreatic surface and minimum width of drain a_0 (Figure 6.48) can be estimated from the following equations:

$$x = (-ky^2/2q) + (q/2k) \quad y_0 = (d^2 - h^2)^{0.5} - d \quad (6-18)$$

$$q = k[(d^2 + h^2)^{0.5} - d] \quad (6-19)$$

where:

k = coefficient of hydraulic conductivity (length/time)

q = seepage rate per unit length of drain (length²/time)

Also, the d , h , x , and y dimensions (length) are as shown on Figure 6.48 and $a_0 = y_0/2$.

Harr (1962) provides analytical solutions for embankments with foundations at great depth (as well as finite depth) and with variable upstream slopes. These procedures allow for treatment of anisotropy using transformed sections (simple expansion or contraction of spatial coordinates to convert an anisotropic zone to an isotropic zone).

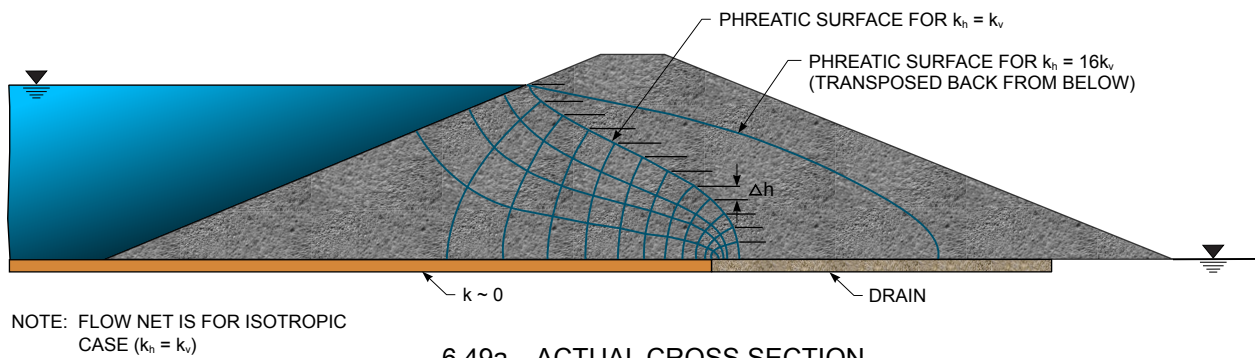

6.49a ACTUAL CROSS SECTION

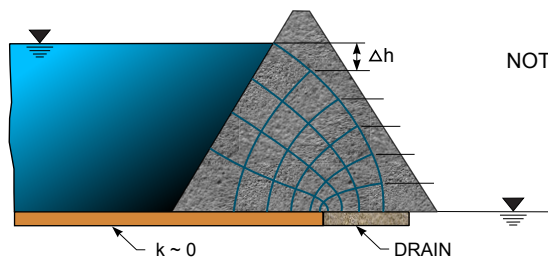

NOTE: HORIZONTAL TRANSFORMATION FACTOR = $\sqrt{\frac{k_v}{k_h}} = \sqrt{\frac{1}{16}} = 0.25$

WHERE: k_v = VERTICAL HYDRAULIC CONDUCTIVITY
 k_h = HORIZONTAL HYDRAULIC CONDUCTIVITY

6.49b TRANSFORMED CROSS SECTION

(USDA, 1973a)

FIGURE 6.49 FLOW NET ANALYSIS FOR ANISOTROPIC CONDITIONS

Kashef (1986) and Mishra and Singh (2005) point out simplifying assumptions for Kozeny's basic parabola and their impact on seepage rate and drain length. The results are compared with numerical methods for zoned embankments.

Coal refuse embankments frequently employ limited width and height internal drains positioned above the base of the dam to intercept seepage and control the phreatic surface. Van Zyl and Robertson (1980) have analyzed a drain of limited width on an impervious base. They estimate the effective width of the drain as approximately $0.1h$ for the condition where $d/h > 2$, provided the drain filter has sufficient capacity. They also recommend that the drain width be sized 50 percent larger than the width determined based on the capacity of the filter, with a minimum dimension of 2 meters.

Analytical solutions provide a means to estimate seepage and phreatic levels for some specific boundary conditions. They can be useful for initial development of flow nets and for interpreting results obtained with numerical modeling, as subsequently discussed.

6.6.2.2.3 Numerical Modeling Approach

As noted previously, the advent of powerful computers has facilitated the use of numerical modeling for evaluating seepage. There are a number of finite element programs that can be used to model seepage for two- and three-dimensional, anisotropic, unconfined and confined flow. The use of such computer programs has several advantages over the use of graphical methods to analyze seepage. Frequently, computer programs support the use of hydraulic conductivity functions (relationships between hydraulic conductivity and pore-water pressure) and thus allow the inclusion of unsaturated flow into the seepage model. Computer programs can more easily accommodate anisotropic

hydraulic conductivities and complicated soil/rock geometries, including varying anisotropy ratios. Transient analyses are also possible using numerical methods if water content data for each material in the model are available.

Computer programs utilizing numerical methods frequently provide several alternatives for modeling boundary conditions, including the ability to model internal drainage systems of limited width and height located above the base of the embankment. However, not all of these alternatives will result in a realistic model. Therefore considerable judgment must be used if realistic results are to be achieved. As noted previously, accurate geometry and realistic representation of boundary conditions are vitally important when setting up a seepage model. The resulting model should be checked using a more simple approach (e.g., flow nets) to determine whether the resulting flow paths and related directional orientation of velocity vectors, predicted total head, and predicted pressure heads are realistic.

The application of numerical methods for seepage analyses at fine coal refuse impoundments has been presented in publications by Snow et al. (2000) and Thacker (2000). These studies present models for steady-state flow conditions with anisotropic hydraulic conductivity for various material property zones, and they use specified heads in the embankment or as boundary conditions to simulate impoundment levels or drains. For numerical models of this type, flow vectors and hydraulic gradients should be checked to verify that values are reasonable and that mass balance is maintained.

6.6.2.3 Seepage Control Measures

6.6.2.3.1 Granular Drain and Filter Requirements

Drains and filters made of aggregate materials are used within and under coal refuse embankments to collect seepage and to lower pore-water pressures in parts of embankment where internal erosion or unstable conditions might otherwise develop. The use of drains and filters in coal refuse embankments is also discussed in [Section 6.3](#). Technical requirements for drains are discussed in the following pages.

For a drainage system to be effective, the following criteria must be satisfied:

- The hydraulic conductivity must increase in the direction of flow.
- The particles in the system must be stable against the seepage forces.
- Material segregation during construction must be prevented so that grain-size characteristics are uniform throughout the drain.
- The materials must not be susceptible to clogging over time.
- The materials must be durable and not decompose over time.

Filter criteria must be satisfied for transitions between a drain and adjacent portions of an embankment and between zones of finer and coarser materials within the embankment. As water percolates through soil or refuse materials, seepage forces in the direction of flow are exerted on the soil/material particles. Where water flows from a fine soil into a coarse soil, it may transport fine particles into the voids in the coarser material. This erosion of the fine material can lead to piping, a phenomenon where a path of much higher hydraulic conductivity that could ultimately cause a failure is developed within an embankment. When the difference in grain-size distribution for adjacent embankment zones is too great to prevent piping, a filter or layer of material of intermediate particle size needs to be placed between the two zones. When adjacent embankment and drainage system zones differ greatly in particle size, two or more filter zones with graduated particle sizes may be needed.

The U.S. Army Corps of Engineers (USACE, 1993) guidance for selecting materials for successive layers of a filter and drainage system, stated as rules, is provided in the following:

To prevent particles of a fine soil from washing into an adjacent coarser soil:

- Rule 1: The criteria presented in [Table 6.47](#) should be followed.
- Rule 2: Ideally, grain-size curves for the base and filter soils should be approximately parallel. For gap-graded base materials (sometimes the case with coarse coal refuse), filter criteria that exclude the coarser portion of the base soil should be applied. Also adjustments can be made to exclude particles larger than the No. 4 (4.75-mm) sieve. The filter should be designed to protect the fine matrix. For gap-graded and broadly-graded materials, considerable care and judgment must be employed in identifying the grain-size portion of the base soil to be filter-protected so that sufficient capacity to transmit seepage flow from the base soil is provided (USB, 2007a). Alternatively, tests can be conducted in the laboratory to select the appropriate filter (Sherard and Dunnigan, 1985).

For hydraulic conductivity consistent with adequate discharge capacity:

- Rule 3: $\frac{D_{15 \text{ filter soil}}}{D_{15 \text{ base soil}}} \geq 3 \text{ to } 5$ (6-20)
- Rule 4: The portion passing the No. 200 sieve should be less than or equal to 5 percent, and the fines should be cohesionless.

To prevent segregation during placement:

- Rule 5: The restrictions on filter grain size presented in [Table 6.48](#) should be followed.
- Rule 6: $D_{max} \leq 3$ inches.

The USACE (1993) provides guidance for filters within gap-graded and broadly-graded soils. The latter condition may be particularly relevant because the grain-size distribution associated with coarse coal refuse embankments is frequently either gap-graded or broadly-graded. Additionally, the above guidelines (Rule 6) may require adjustment in some project-specific situations where large mine rock overburden is used in downstream zones.

Where a perforated drainpipe is the final element of a drainage system, a well-graded gravel that will not wash through the perforations or slots should be placed around the pipe. The D_{85} size of the gravel should be greater than the width of the perforations or slots. Experience has shown that drainpipes placed with perforations directed downward are less likely to clog. Geotextiles should not be placed directly against a perforated or slotted pipe due to the potential for clogging. Instead, a zone of sand or aggregate should be placed around the pipe and then the filter (geotextile or another granular layer) should be placed around the aggregate (France, 2004)

The discharge capacity of all portions of a drainage system must be checked for adequacy, particularly for thin horizontal drains. This can be accomplished by very simple approximate calculations using the Darcy equation presented earlier in this section. Cedergren (1989) contains several useful examples of this calculation.

The NRCS (1994) and the USB (2007a) also provide guidance on filter criteria, including the use of perforated pipes in drains. These criteria may be applied to coal refuse disposal facilities. McCook

TABLE 6.47 FILTER CRITERIA AS A FUNCTION OF BASE SOIL AND PERCENT PASSING NO. 200 SIEVE

Base Soil Category	Base Soil Description	Percent Finer Than No. 200 (0.075-mm) Sieve ⁽¹⁾	Filter Criteria ⁽²⁾
1	Fine silts and clays	> 85	$D_{15 \text{ filter soil}} \leq 9 D_{85 \text{ base soil}}$ $D_{15 \text{ filter soil}} \geq 0.2 \text{ mm}$
2	Sands, silts, clays, and silty to clayey sands	40 to 85	$D_{15 \text{ filter soil}} \leq 0.7 \text{ mm}$
3	Silty and clayey sands and gravels	15 to 39	$D_{15 \text{ filter soil}} \leq 0.7 \text{ mm} + [4(D_{85 \text{ base soil}}) - 0.7 \text{ mm}] \times [(40 - A)/(40 - 15)]^{(3,4)}$
4	Sands and Gravels	< 15	$D_{15 \text{ filter soil}} \leq 4 \text{ to } 5 D_{85 \text{ base soil}}^{(5)}$

- Note: 1. Category designation for soil containing particles larger than 4.75 mm is determined from a gradation curve of the base soil that has been adjusted to 100 percent passing the No. 4 (4.75-mm) sieve.
 2. Filters should have a maximum particle size of 3 inches (75 mm) and a maximum of 5 percent passing the No. 200 (0.075-mm) sieve with a PI = 0. To provide sufficient hydraulic conductivity, filters must have $D_{15 \text{ filter soil}} \geq 4 D_{15 \text{ base soil}}$, but not less than 0.1 mm.
 3. A is the percent passing the No. 200 sieve using the adjusted grain-size curve.
 4. When $4 D_{85 \text{ base soil}} < 0.7 \text{ mm}$, use $D_{15 \text{ filter soil}} = 0.7 \text{ mm}$.
 5. In Category 4, the $D_{15 \text{ filter soil}} \leq 4 D_{85 \text{ base soil}}$ criterion should be used for filters beneath riprap subject to wave action and for drains that may be subjected to violent surging and vibration.

(USACE, 1993)

(2006) presents an overview of design and construction issues for pipes in drain systems, comparing criteria published by the USACE, NRCS and USBR and methods for estimating inflow capacity. Slotted pipe generally is less prone to clogging and has a much larger inflow capacity than circular perforated pipe. However, perforated pipe probably has higher strength than slotted or screened pipe, especially when the perforations are relatively small in diameter and widely spaced. Care should be exercised in selecting pipe materials, recognizing that: (1) slotted single-wall corrugated tubing has been vulnerable to crushing in some drain installations and (2) single-wall corrugated pipe is seldom used in the design of significant- and high-hazard-potential dams. Pipes in drains should generally be designed to withstand the maximum height of backfill over the pipe, and they should be protected against damage during construction. Care should be exercised in evaluating the load-carrying capacity of perforated pipe, as the perforations can affect the strength of the pipe. Since the outer rings of

TABLE 6.48 RESTRICTIONS ON FILTER PARTICLE SIZE TO LIMIT SEGREGATION

Minimum $D_{10 \text{ filter}}$ (mm)	Maximum $D_{90 \text{ filter}}$ (mm)
< 0.5	20
0.5 to 1.0	25
1.0 to 2.0	30
2.0 to 5.0	40
5.0 to 10	50
10 to 50	60

(USACE, 1993)

corrugated pipe carry the majority of the load, the effect of perforations on the inner rings is thought to be negligible (< 1 percent). Double-wall, corrugated and slotted HDPE and PVC pipe is available in a variety of diameters.

It should also be noted that all materials used in drainage systems for a coal refuse embankment should be resistant to corrosion from exposure to seepage leachates. Guidelines for selecting such materials are presented in Chapter 11.

Drain Capacity and Grade

Drains should be sized with sufficient dimensions and grade (typical minimum slope of 1 percent) to convey the estimated drain demands based on the seepage analyses multiplied by a safety factor. It is recommended that drains have the capacity to convey 10 times the estimated drain demand (Cedergren, 1989). It is also recommended that drains installed in trenches should include a minimum width determined on the basis of capacity requirements and constructability considerations (typically 3 feet) of the drain core material surrounded by specified minimum thicknesses for the surrounding filter aggregate(s). For drains at the ground surface or the coal refuse working surface, the minimum width of the core material should be determined on the basis of constructability. Additional discussion of drain and filter dimensioning is available from the USBR (2007a).

Detailed review of the hydraulic gradients in the vicinity of a drain may lead to adjustments in drain dimensions. McCook (2002) provides a discussion of critical hydraulic gradients and notes that cohesive soils such as clays will sustain significant gradients when confined. Indraratna and Radampola (2002) provide further guidance relative to critical gradients at drain filters.

Drain Configurations

The above criteria for drain capacity and grade apply to aggregate drains of various configurations, including trench drains, finger drains, blanket drains, chimney drains and discrete longitudinal drains. In determining the thickness of drainage layers, the layer inclination and the method of placement in addition to hydraulic conductivity requirements must be considered. Drainage layers placed by machine should generally have a thickness of at least 18 inches. Layers placed very carefully by hand in confined spaces or machine-placed layers for which there is construction oversight and QC compliance monitoring should have a minimum thickness of 12 inches. If adjacent materials could migrate into drainage layers during placement, the thicknesses should be increased. Where machine placement is used for constructing steeply inclined drainage layers within an embankment, each layer should be sufficiently thick to permit efficient operation of the construction equipment. Filters and drainage structures that are so thin that a small amount of contamination during construction would reduce the effective size to below design requirements are generally considered to be inadequate.

Another factor that may impact the thickness of drainage layers is the source and grain size of the granular material. Granular drains should be compatible with the selected filter material. The minimum thickness of a well-graded rock drain must be more than the maximum size of the rock, and gradation requirements should be strictly monitored so that there is no concentration of large rock. If uniformly-graded rock is used for a drain, then an increase in the minimum thickness should be considered. A minimum thickness equal to twice the maximum rock size should provide predictable flow capacity.

6.6.2.3.2 Geotextile-Wrapped Drains

At some coal refuse embankments, geosynthetic materials have been used to separate granular drain material from soils or coal refuse as a replacement for or supplement to granular filters. In addition to some state dam safety agencies, the Nation Dam Safety Review Board currently recommends that geotextiles not be used as filters in locations where they would be critical to the safety of an embankment dam, citing concerns about the long-term capability of the geotextile to function with-

out deterioration or clogging. Critical drain applications and areas of concern include internal drains for controlling the phreatic surface for embankment stability and drains and filters that are designed to minimize the potential for piping of susceptible soils. FEMA, in a publication planned for 2009, is addressing the use of geotextiles in embankment dams.

MSHA has generally permitted the use of geotextiles as filters in slurry impoundments provided that testing using site-specific materials demonstrates acceptable behavior with respect to clogging and there is sufficient instrumentation to monitor the phreatic level. In addition to monitoring of the phreatic level, the seepage quantity from geotextile-wrapped drains should be monitored as an additional indicator of how the geotextile is performing. In recognition of the potentially more critical seepage conditions that can exist in other dams with significant hydraulic head and narrow cross section (e.g., fresh water dams), and until the use of geotextiles is accepted in this application, MSHA advocates that granular filters be used in such significant- and high-hazard-potential dams where filters are critical to safety.

As discussed in [Section 6.5.5](#), a geosynthetic is a planar polymeric material used with soil or rock as an integral part of a civil engineering project, structure, or system. Geotextiles are a subcategory of geosynthetics and are made from woven or nonwoven fabric that allows the passage of water. At refuse disposal facilities, geotextiles have often been used as filters in internal drains. The geotextiles restrict movement of soil particles as water flows into the drain. Typically, non-woven geotextiles are used for filtration purposes. However, woven monofilament geotextiles have performed well in filter applications, and knit geotextiles have been used around perforated pipes as part of a two-stage filter in combination with a primary sand filter layer.

AASHTO M288, "Standard Specification for Geotextile Specification for Highway Applications," (AASHTO, 2008) provides reference information concerning material properties, applications related to highway use (including subsurface drainage) and construction guidance for the use of geotextiles in drainage applications. FHWA Publication No. HI-95-038, "Geosynthetic Design and Construction Guidelines," (Holtz et al., 1998) is a comprehensive reference providing information on the retention criterion, hydraulic conductivity criterion, clogging resistance criterion and survivability criterion, as discussed in subsequent paragraphs.

Geotextiles, like graded granular filters, require engineering design if they are to perform as desired. Unless flow requirements, piping and clogging resistance, and constructability requirements are accurately specified, the geotextile/soil filtration system may not perform properly. Also, as with graded granular filters, construction using geotextiles must be monitored to verify that installation is performed correctly and that the geotextiles are not damaged during installation.

Design of geotextile filters is comparable to design of graded granular filters. A geotextile is similar to a soil in that it has openings (voids) and filaments and fibers (particles). However, the geometric relationship between filaments and openings is more complex than the relationship between particles and voids. In geotextiles, opening size can be measured directly, whereas for soils pore size is a function of particle size. Because pore size can be directly measured, relatively simple relationships have been developed between the pore sizes and particle sizes of the soil to be retained. Three filtration concepts are used in the design process:

1. If the size of the largest opening in the geotextile filter is smaller than the larger particles of embankment material, the filter will retain the embankment material.
2. If the smaller openings in the geotextile are sufficiently large enough to allow smaller particles of embankment material to pass through, then the geotextile will not clog.
3. The number of openings in the geotextile should be such that adequate flow can be maintained even if some of the openings become clogged.

The above simple concepts and analogies to soil filter design criteria have been used to establish design criteria for geotextiles (Holtz et al., 1998). Specifically, these criteria require that geotextiles must:

- Be capable of retaining soil or other embankment material (retention criterion)
- Allow water to pass (hydraulic conductivity criterion)
- Be functional throughout the life of the structure (clogging resistance criterion)
- Survive the installation process (survivability criterion)

Retention Criterion

For steady-state flow conditions:

$$AOS \leq B D_{85 \text{ soil}} \quad (6-21)$$

$$AOS \approx O_{95} \quad (6-22)$$

where:

AOS = apparent opening size (length)

O_{95} = opening size in the geotextile for which 95 percent are smaller (length)

B = coefficient (dimensionless)

D_{85} = soil particle size for which 85 percent are smaller (length)

B ranges from 0.5 to 2 and is a function of the type of soil to be filtered, its density, the uniformity coefficient C_u (for granular soils), the type of geotextile (woven or nonwoven), and the flow conditions. For sands, gravelly sands, silty sands, and clayey sands (with < 50 percent passing the No. 200 sieve), B is a function of C_u as defined below:

$$C_u \leq 2 \text{ or } \geq 8: \quad B = 1$$

$$2 \leq C_u \leq 4: \quad B = 0.5 C_u$$

$$4 < C_u < 8: \quad B = 8 C_u$$

where:

$$C_u = D_{60}/D_{10} \quad (6-23)$$

For silts and clays, B is a function of the type of geotextile:

$$\text{Woven} \quad B = 1 \quad O_{95} \leq D_{85}$$

$$\text{Nonwoven} \quad B = 1.8 \quad O_{95} \leq D_{85}$$

$$\text{For both} \quad AOS \text{ or } O_{95} \leq 0.3 \text{ mm}$$

Due to their random pore characteristics and, for some types, their “felt-like” nature, nonwoven geotextiles will generally retain finer particles than a woven geotextile of the same apparent opening size. Therefore, a value of $B = 1$ is more conservative for nonwoven geotextiles than it is for woven geotextiles.

Hydraulic Conductivity Criterion

For non-critical applications (less severe conditions):

$$k_{\text{geotextile}} \geq k_{\text{retained material}} \quad (6-24)$$

For critical applications (severe conditions):

$$k_{\text{geotextile}} \geq 10 k_{\text{retained material}} \quad (6-25)$$

Guidelines for determining critical nature or severity for drainage applications are provided in [Table 6.49](#). Geotextile permittivity ψ can be defined as:

$$\psi = k/t \quad (6-26)$$

where:

- k = Darcy coefficient of hydraulic conductivity (length/time)
- t = geotextile fabric thickness (length)

Geotextile permittivity should meet the following requirements:

- $\psi \geq 0.5/\text{sec}$ for < 15 percent passing No. 200 sieve
- $\psi \geq 0.2/\text{sec}$ for 15 to 50 percent passing No. 200 sieve
- $\psi \geq 0.1/\text{sec}$ for > 50 percent passing No. 200 sieve

Clogging Resistance Criterion

For actual flow capacity, the hydraulic conductivity criterion for non-critical applications is conservative because an equal quantity of flow through a relatively thin geotextile takes significantly less time than flow through a thick granular filter. Where flow reduction is judged not to be a problem, such as in clean, medium to coarse sands and gravels, Equation 6-24 may be used. Even so, some pores in the geotextile may become blocked or plugged with time. Therefore, for critical or severe applications, Equation 6-25 should be used to provide an additional level of conservatism. FEMA, in a document to be published in 2009, suggests even greater conservatism with $k_{\text{geotextile}} = 10$ to $100 k_{\text{retained material}}$ and indicates that the French (Degoutte and Fry, 2002) use $100 k_{\text{retained material}}$ for dams.

The required flow rate through the system q should also be determined, and the geotextile and drainage aggregate should be selected to provide adequate capacity. As indicated previously, flow capacities should not be a problem for most applications. In some situations, however, such as where geotextiles are used in multiple stage filters around a perforated or slotted pipe (pipe wraps), portions of the geotextile may not function effectively. For these applications, the following criteria should be used together with the hydraulic conductivity criteria:

$$q_{\text{required}} = q_{\text{geotextile}} (A_g/A_t) \quad (6-27)$$

where:

- A_g = geotextile area available for flow (length²)
- A_t = total geotextile area (length²)

TABLE 6.49 GUIDELINES FOR EVALUATING CRITICAL NATURE OR SEVERITY FOR DRAINAGE APPLICATIONS

Category	Critical	Less Critical
<u>A. Critical Nature of the Project</u>		
1. Risk of loss of life and/or structural damage due to drain failure	High	None
2. Repair costs versus installation costs of drain	Much Higher	Equal or Less
3. Evidence of drain clogging before potential catastrophic failure	None	Yes
<u>B. Severity of the Conditions</u>		
1. Soil to be drained	Gap-graded, pipable or dispersible	Well-graded or uniform
2. Hydraulic gradient	High	Low
3. Flow conditions	Dynamic, cyclic or pulsating	Steady-state

(ADAPTED FROM CARROLL, 1983)

Clogging resistance for less critical/less severe conditions should be designed to meet:

$$O_{95 \text{ geotextile}} \geq 3D_{15 \text{ retained material}} \tag{6-28}$$

This relationship applies to soils with $C_u > 3$. For $C_u < 3$, a geotextile with the maximum AOS value should be selected. In situations where clogging is possible (e.g., gap-graded or silty soils), the following optional qualifiers may be applied:

- For nonwovens – porosity of the geotextile $n \geq 50$ percent
- For woven monofilament and slit-film wovens – percent open area (POA) ≥ 4 percent

Most common non-woven geotextiles have porosities much greater than 70 percent. While most woven monofilaments easily meet the criterion of $POA \geq 4$ percent, tightly woven slit films do not and are therefore not recommended for subsurface drainage applications.

For critical/severe conditions, geotextiles should be selected in accordance with the retention and hydraulic conductivity criteria described previously. A filtration test should be conducted to check for clogging using samples of on-site materials and hydraulic conditions such as long-term flow tests or the gradient ratio test, which is described in ASTM D 5101, “Standard Test Method for Measuring the Soil-Geotextile System Clogging Potential by the Gradient Ratio.” Dam safety agencies have expressed concern about the use of geotextiles in critical filters and drains (e.g., structures critical for the control of internal erosion and piping failures) due to susceptibility to:

- Excessive clogging from buildup of fines at the face of the geotextile or from biological, fungal or mineral matter buildup
- Separation at interfaces, junctions, connections and boundaries
- Undetected damage during construction.

These performance problems are related to the following mechanisms: (1) inability to support the seepage discharge face, (2) excessive clogging or piping, (3) stress-induced distortion, (4) environmental degradation, (5) slope instability, and (6) rupture. Designers should consider these concerns and performance issues when using geotextiles and, as part of the planning process, should discuss the acceptability of any proposed application with MSHA and state agencies.

Talbot et al. (2000) describe concerns about the use of geotextiles in dams, including the propensity for excessive clogging because seepage forces move the geotextile away from the base soil and into the voids of the adjacent drain. Thus, separation can occur between the base soil and geotextile allowing fine particles from the base soil to accumulate at the interface, thus “blinding” the filter. Blinding can also occur if there are open voids in the base soil or if the base soil surface is irregular and has poor contact with the geotextile. These concerns can be addressed through: (1) use of fine gravel (about ¾-inch to 1½-inch maximum size) for the drainage layer to improve contact with the base soil (Giroud, 1997; van Zyl and Robertson, 1980), (2) grading the base soil surface smooth and placing the geotextile in contact with the base soil with a minimum of wrinkles, and (3) minimizing vertical or steeply inclined slopes (FEMA, to be published in 2009).

The potential for particulate clogging can be addressed through application of filter criteria, and chemical and biological clogging can be addressed based on evaluation of the drain environment and/or testing, as discussed subsequently. Stress-induced distortion, environmental degradation, and stability can be addressed with design and laboratory testing procedures.

Chemical clogging of geotextiles at coal refuse disposal sites will most likely be associated with iron and manganese oxidation and deposition, although it is possible that calcium carbonate precipitation may also be encountered. These processes are affected by chemical reactions and biological activity that varies depending on whether the environment is anaerobic and aerobic. Factors that may lead to problems with clogging of drains are discussed by Smith and Hosler (2006). Research into predictive methods has generally concentrated on biological clogging and the role of microbial activity, and more work is necessary for prediction of potential chemical clogging. Long-term hydraulic conductivity testing procedures can be used to evaluate the potential effect of chemical clogging.

Koerner and Koerner (2005) provide drainage reduction factors for determination of the design flow rate or transmissivity of geotextiles. These reduction factors address soil clogging and blinding, reduction in void space, and chemical and biological clogging. Koerner and Koerner recommend reduction factors to the design flow capacity of a geotextile of between 1.2 and 1.5 for landfill filters to account for chemical clogging, and they suggest adoption of a high reduction factor where total suspended solids in the permeating liquid is greater than 5,000 mg/l. Similarly, they recommend reduction factors of between 2 and 5 to the design flow capacity of a geotextile to account for biological clogging and suggest adoption of a high reduction factor where biochemical oxygen demand (BOD) is greater than 5,000 mg/l.

The potential for biological clogging can be examined in accordance with ASTM D1987, “Standard Test Method for Biological Clogging of Geotextile or Soil/Geotextile Filters.” However, before using this test, Mackey and Koerner (1999) recommend that to facilitate interpretation of the results of the test the physical, chemical and biological processes at the site be evaluated and understood. If clogging is a concern, a higher-porosity geotextile can be used, and/or the drain design and operation can include an inspection and maintenance program for flushing the drainage system. For nonwoven geotextiles, Luettich et al. (1992) recommend using the largest porosity available, but not less than 30 percent; for woven geotextiles they recommend using the largest POA, but not less than 4 percent. Because of concerns for clogging, geotextiles with the largest opening sizes that satisfy piping requirement should generally be used.

Survivability Criterion

For filtration and drainage applications, if a geotextile is to survive the construction process, certain minimum strength and endurance properties are required. Table 6.50 provides these minimum requirements for less critical/less severe applications. It is important to understand that these minimum survivability parameters are based on empirical data from geotextiles that have performed satisfactorily in drainage applications. These parameters serve as guidelines for selecting geotextiles for most projects. The guidelines are not intended to replace site-specific evaluation, testing, and design.

Geotextile material should be covered subsequent to installation as soon as possible to prevent degradation from sunlight or in accordance with the manufacturer’s recommendations. Geotextile endurance

TABLE 6.50 GEOTEXTILE STRENGTH PROPERTY REQUIREMENTS FOR DRAINAGE GEOTEXTILES^(1,2,3,4)

Property	ASTM Test Method	Units	Geotextile Class 2 ⁽⁵⁾	
			Elongation	
			< 50% ⁽⁶⁾	≥ 50% ⁽⁶⁾
Grab Strength	D 4632	N (lb)	1100 (247)	700 (157)
Sewn Seam Strength ⁽⁷⁾	D 4632	N (lb)	990 (223)	630 (142)
Tear Strength	D 4533	N (lb)	400 ⁽⁸⁾ (90)	250 (56)
Puncture Strength	D 4833	N (lb)	400 (90)	250 (56)
Burst Strength	D 3786	kPa (lb/in ²)	2700 (392)	1300 (189)

- Note:
1. Acceptance of geotextile material shall be based on ASTM D 4759, “Standard Practice for Determining the Specification Conformance of Geosynthetics.”
 2. Acceptance shall be based upon testing of either conformance sampler obtained using Procedure A of ASTM D 4354, “Standard Practice for Sampling of Geosynthetics for Testing,” or on manufacturer’s certifications and testing of quality assurance samples obtained using Procedure B of ASTM D 4354.
 3. Values apply to minimum strength; use value in weaker principal direction. All numerical values represent minimum average roll value (i.e., test results from any sampled roll in a lot shall meet or exceed the minimum values in the table). Lot samples according to ASTM D 4354.
 4. Woven slit film geotextiles will not be allowed.
 5. AASHTO Geotextile Class 2 is the default geotextile selection. The engineer may specify AASHTO Class 3 geotextiles for trench drain applications based on one or more of the following:
 - a) The engineer has found Class 3 geotextiles to have sufficient survivability based on field experience.
 - b) The engineer has found Class 3 geotextiles to have sufficient survivability based on laboratory testing and visual inspection of a geotextile sample removed from a field test section constructed under anticipated field conditions.
 - c) Subsurface drain depth is less than 2 m, drain aggregate diameter is less than 30 mm, and the compaction requirement is ≤ 95 percent of ASTM D 698, “Standard Test Methods for Laboratory Compaction Characteristics of Soil Using Standard Effort (12,400 ft-lbf/ft³ (600 kN-mm³)).”
 6. As measured in accordance with ASTM D 4632, “Standard Test Method for Grab Breaking Load and Elongation of Geotextiles.”
 7. When seams are required. Values apply to both field and manufactured seams.
 8. The required MARV tear strength for woven monofilament geotextiles is 250 N (56 lb).

(ADAPTED FROM AASHTO STANDARD SPECIFICATIONS FOR TRANSPORTATION MATERIALS AND METHODS OF TESTING, PART I SPECIFICATIONS, 2007, BY PERMISSION OF THE AMERICAN ASSOCIATION OF STATE HIGHWAY AND TRANSPORTATION OFFICIALS, WASHINGTON, D.C. USED BY PERMISSION. DOCUMENT MAY BE PURCHASED FROM THE AASHTO BOOKSTORE AT 1-800-231-3475 OR ONLINE AT HTTP://BOOKSTORE.TRANSPORTATION.ORG)

is related to longevity. Geotextiles have been shown to be basically inert materials in most environments and applications. However, some applications may expose the geotextile to chemical or biological activity that could dramatically affect filtration properties or durability. For example, in drains, granular filters and geotextiles can become chemically clogged by iron or carbonate precipitates and biologically clogged by algae and mosses. Biological clogging is a potential problem when filters and drains are periodically inundated then exposed to air. Excessive chemical and biological clogging can significantly affect filter and drain performance, and monitoring with piezometers is recommended.

6.6.2.3.3 Seepage Control along Conduits

Seepage along conduits that pass through coal refuse embankments should be controlled. Two methods for seepage control are filter diaphragms and anti-seep collars (also known as cutoff collars). Since the mid-1980s, the use of anti-seep collars has become less common and filter diaphragms have become more widely used (Van Aller, 1998). Many dam safety agencies require the use of filter diaphragms because of the many instances where seepage problems have occurred along conduits even when anti-seep collars were used. The primary advantage of filter diaphragms is the relative ease of construction as compared to anti-seep collars, particularly with respect to compaction around conduits. The presence of anti-seep collars complicates compaction around conduits, and accordingly they are more likely to function poorly due to construction flaws. Also, filter diaphragms are considered to be a better measure for mitigating the consequences of embankment cracking associated with the presence of a conduit. Filter diaphragms should be constructed with suitable filter materials, and careful placement is required during construction. The following sections present basic design considerations for both filter diaphragms and anti-seep collars.

Filter Diaphragms

A filter diaphragm is used for intercepting seepage through backfill pores or cracks and to prevent internal erosion of the backfill materials along buried conduit installations. To meet filtration and drainage requirements, filter diaphragms may consist of a single zone or multiple zones of granular material. The guidance for dimensioning filter diaphragms provided in the following text is taken from the USDA (1985) and NRCS (2007b). Van Aller (1998) discusses various aspects of filter diaphragm design, and McCook (2002) discusses site-specific conditions that should also be considered.

Filter diaphragms should be located approximately parallel to the centerline of the embankment and approximately perpendicular to the direction of seepage flow, and should extend horizontally and vertically into adjoining portions of the embankment and foundation. In homogeneous dams, filter diaphragms should be located using the following criteria:

- Downstream of the cutoff trench
- Downstream of the centerline of the dam if there is no cutoff trench
- Upstream of a point where the embankment cover (from the upstream face of the diaphragm to the downstream face of the embankment) is at least one-half of the difference between the elevation of the top of the filter diaphragm and the maximum potential impoundment water level

In zoned embankments, the filter diaphragm should be located downstream of the core zone and/or cutoff trench, in accordance with the minimum cover guidance for homogeneous dams. In instances where the downstream shell of a zoned embankment is more pervious than the diaphragm material, the diaphragm should be located at the downstream face of the core zone.

Provisions should be made for discharging seepage and groundwater collected by the filter diaphragm. These provisions could include tying the diaphragm into other drainage systems in the foundation,

tying into internal embankment drains or designing/constructing a separate outlet for the filter diaphragm. Such an outlet should be designed with the assumption that the hydraulic conductivity in the zone upstream of the filter diaphragm is 100 times the hydraulic conductivity in the compacted embankment material. This zone should have a cross-sectional area equal to the area of the filter diaphragm, and the length of the seepage path should equal the distance from the embankment upstream toe to the filter diaphragm. This higher hydraulic conductivity is intended to account for partially-filled cracks and openings in the upstream zone. An advantage of having a separate outlet for the filter diaphragm is that the seepage outflow can be monitored separately from other seepage flows and will provide feedback as to the performance of the diaphragm system over time.

For rigid conduits, the NRCS (2007b) recommends that filter diaphragms should extend the following minimum distances from the conduit surface (Figure 6.50):

1. Horizontally and vertically upward 3 times the outside diameter of circular conduits or the vertical dimension of rectangular box conduits except that:
 - a. The vertical extension need be no higher than the maximum potential impoundment level.
 - b. The horizontal extension need be no further than 5 feet from the sides and slopes of any excavation for installation of the conduit.
2. Vertically downward from the conduit:
 - a. Filter diaphragms should extend from the pipe support 1.5 times the outside diameter of circular conduits or outside vertical dimension of box conduits or to the top of rock, whichever is shallower.
 - b. Alternatively, for conduit settlement ratios δ of 0.7 and greater, filter diaphragms should extend the greater of 1 foot beyond the bottom of the trench excavation for the conduit or 2 feet. The diaphragm should be terminated at the surface of bedrock when it occurs within this distance. Additional control of general seepage through an upper zone of weathered rock may be needed. The conduit settlement ratio δ is defined in NRCS (2007a) and Technical Release-5 (TR-5) by the USDA (1958) and requires a complex computation. On firm foundations with $\delta = 0.7$ or greater (the conduit settlement ratio for pipe on rock is 1.0), the filter diaphragm should extend below the pipe to rock, or at least 2 feet.

For flexible conduits, NRCS recommends that filter diaphragms be designed to extend in all directions a minimum of 2 times the outside diameter from the surface of the conduit, except that the diaphragm need not extend beyond the limits in 1a and 1b described above or beyond a bedrock surface beneath the conduit.

Filter diaphragms should have a minimum thickness of 3 feet, but the thickness specified should be appropriate for the level of quality control and supervision during construction. If a multi-zone system is employed to satisfy filter criteria, a minimum thickness of 1 foot should be used for any single zone. Greater thickness may be required as dictated by: (1) flow capacity requirements, (2) the need to tie the filter diaphragm into embankment internal or foundation drains, or (3) the need to accommodate construction methods. An example design for a filter diaphragm associated with a decant pipe is shown in Figure 6.51.

Some state regulatory agencies have developed specific guidance on filter diaphragms. Also, McCook (2002) discusses site-specific conditions that may warrant enlarging the filter diaphragm relative to

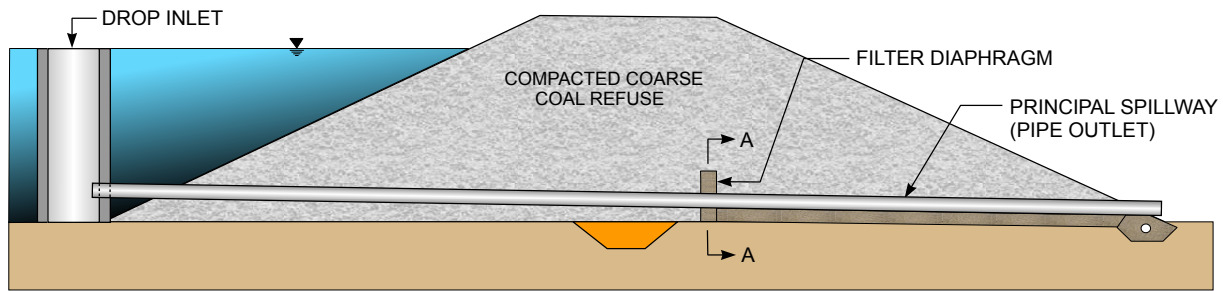

PROFILE THROUGH COAL REFUSE EMBANKMENT

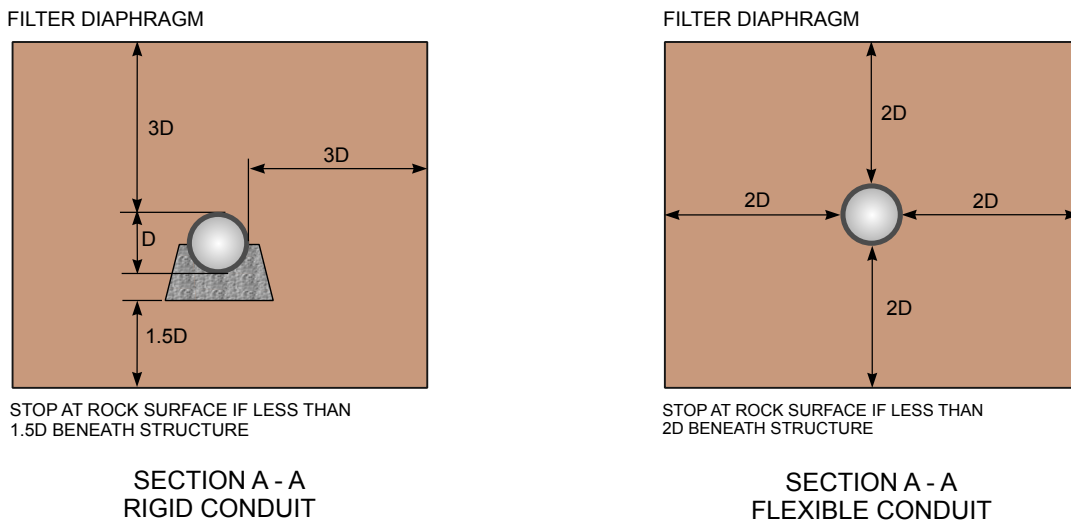

(USDA, 1985)

FIGURE 6.50 FILTER DIAPHRAGM DESIGN FOR CONDUIT

the minimum guidance cited above. These conditions include foundations with varying rock surfaces, soft soils, and situations where there is potential for differential settlement and related strain.

Anti-seep Collars

Cutoff or anti-seep collars are intended to minimize seepage along the contact between the outside surface of a conduit and an embankment. Van Aller (2004) and FEMA (2005a) provide compelling reasons to use filter diaphragms rather than anti-seep collars. For low-hazard-potential structures with dam heights of 35 feet or less and storage volume less than 3,000 acre-feet, the NRCS (2002) allows consideration of anti-seep collars. In coal refuse embankment dams, there may be site-specific reasons to use anti-seep collars. For example, during early stages of construction, installation of anti-seep collars may be preferable to an internal drainage structure that, in the case of downstream construction, could ultimately be located relatively far upstream and perhaps beneath the impoundment during later stages of construction. In such situations, the pipe and collar backfill should be designed so as to minimize the potential for concentrated seepage zones and internal erosion.

Cutoff collars have been fabricated using concrete, steel, and plastic for consistency with conduit materials. The intent of their use is to increase the length of percolation along the conduit contact

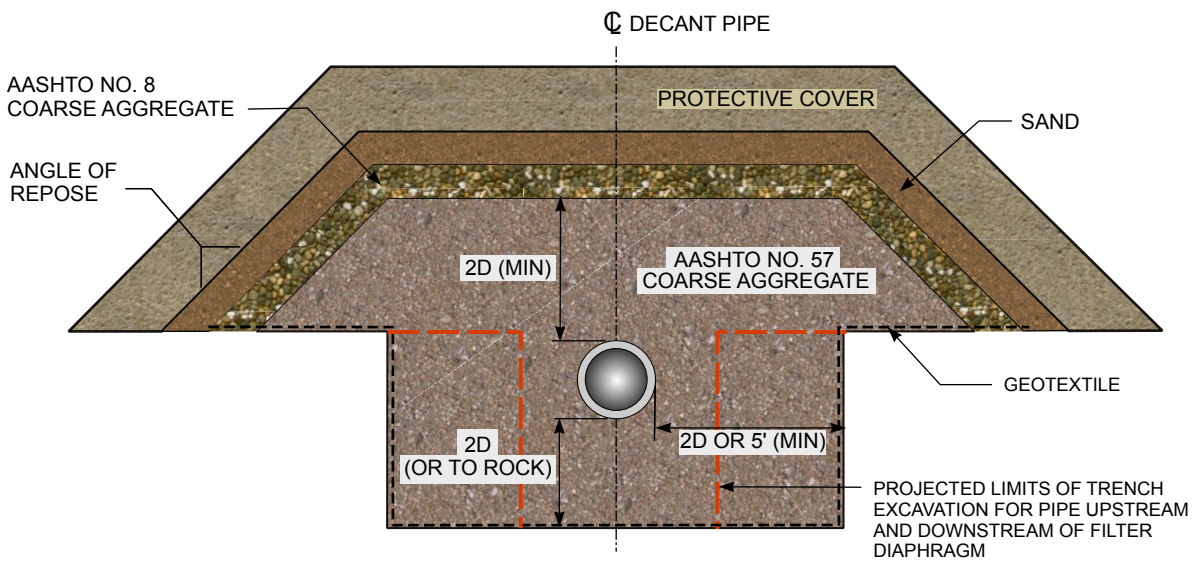
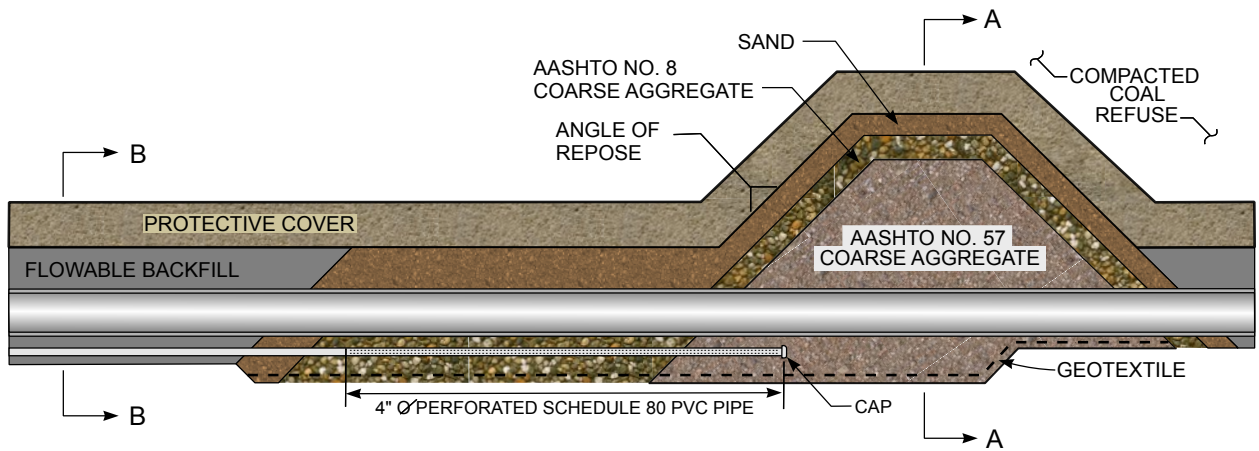

SECTION A - A

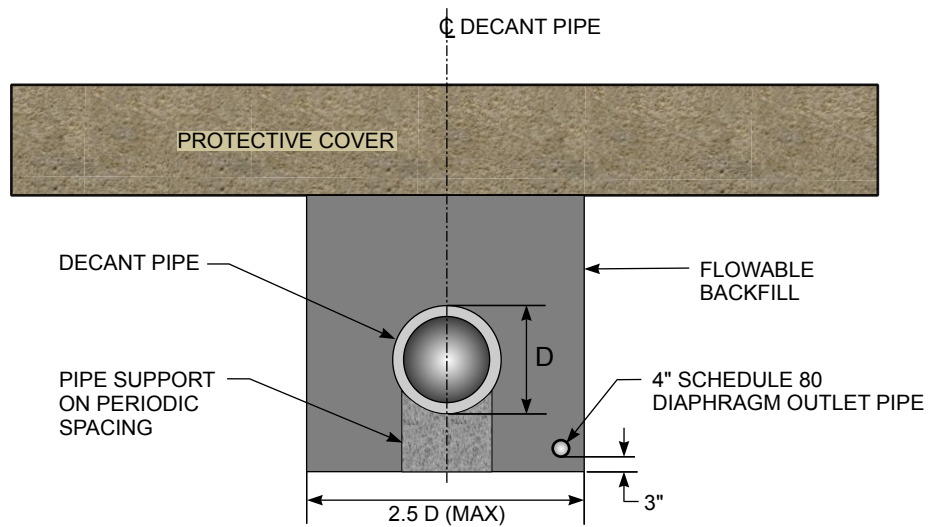

SECTION B - B

FIGURE 6.51 EXAMPLE DESIGN CONFIGURATION FOR FILTER DIAPHRAGM AND DECANT PIPE

surface by 20 to 30 percent for significant- and high-hazard-potential dams (USBR, 1987a). For a conduit on an earth foundation, the cutoff collar should completely encircle the conduit. Where the foundation is sound rock and good contact along the base is expected, cutoff collars will need to extend only to a depth sufficient for keying into the rock foundation. Cutoff collars should be separated from rigid conduits using watertight fillers (gasket or seal) to avoid introducing concentrated stresses into the walls of the conduit. Non-rigid collars can be attached or clamped to flexible conduits using gaskets that accommodate conduit deformation such that a watertight connection is achieved.

For small, low-hazard-potential dams, the NRCS (2002) recommends the use of filter diaphragms unless it is determined that anti-seep collars will adequately serve the purpose. If anti-seep collars are used, the NRCS recommends increasing the flow path along the conduit by at least 15 percent, with 10- to 25-foot spacing between collars.

6.6.2.3.4 Relief Wells

If a pervious layer underlies a relatively impervious layer beneath the toe of an embankment slope, pore-water pressures can build up in the pervious layer to produce an artesian effect if drainage downstream is impeded and the layer is recharged upstream by groundwater, seepage from the impoundment, or rainfall. If artesian water pressure must be reduced for stability, relief wells can be used, as shown in [Figure 6.52](#).

Water collected by relief wells is usually conducted through a horizontal overflow pipe at the ground surface and discharged into a lined drainage ditch near the toe of the embankment. With this collection method, the phreatic surface can be lowered to the ground surface. If a greater lowering of head is required, the outfalls from the wells and the collection drain can be lowered below the ground surface provided that they can be connected to the collection drain through a discharge pipe. To allow for inspection and maintenance, relief well casings should extend to the ground surface.

The spacing required for relief wells depends on the geology and groundwater hydrology at the site. As with embankment seepage modeling, an analysis should be performed to evaluate the impact of relief wells on foundation pressures. Numerical modeling is well suited to such an analysis, but requires an understanding of groundwater conditions, including geometry, pre-construction piezometric levels and the connection of the pervious strata with recharge features such as the impoundment or local aquifers. In instances where the model can be sufficiently simplified, flow nets can be used successfully. As a check, an estimate of the required spacing of relief wells can be made using methods presented by Leonards (1962). Given the limitations inherent in this type of modeling, the adequate function of the relief wells should be monitored with piezometers. A relief well system can be readily expanded if the initial configuration fails to produce the desired reduction in piezometric head.

Attention should be given to relief well design details so that the wells meet performance requirements and can be properly inspected and maintained. The chemical content of the water to be recovered should be evaluated to determine if any special precautions are needed for preventing corrosion of any part of the relief well system. The diameter of the internal perforated pipe depends on the anticipated flow volume, but should be no less than 6 inches. To facilitate inflow and to prevent clogging, relief wells should be surrounded by a filter designed according to the requirements discussed earlier in this section.

The annulus around the portion of the relief well above the pervious layer should be sealed with an impervious material (such as hydrated bentonite or a cement-bentonite mixture) or concrete to prevent upward flow of water around the pipe. It may be necessary to temporarily lower the water level in the relief well during the construction of this seal.

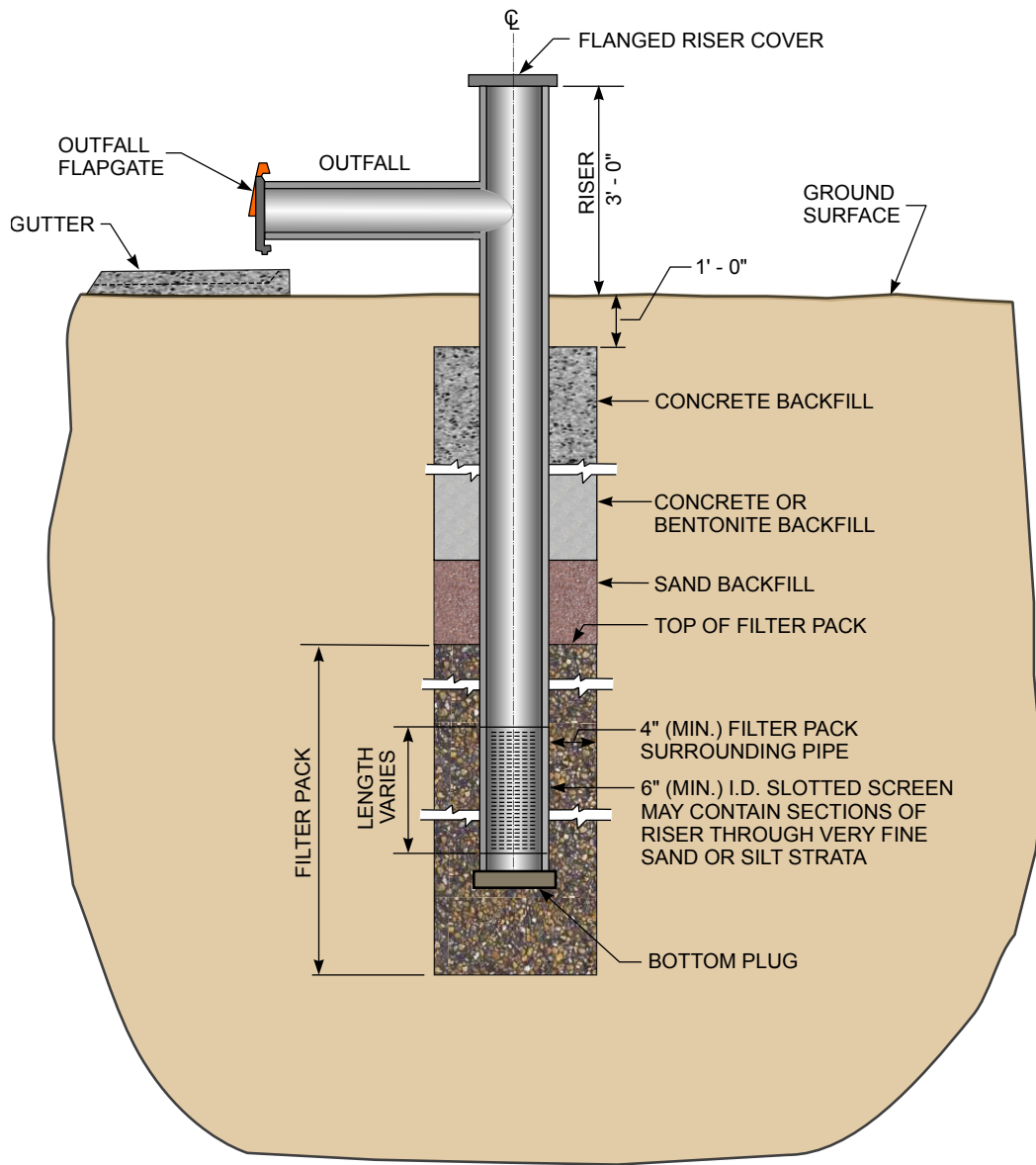
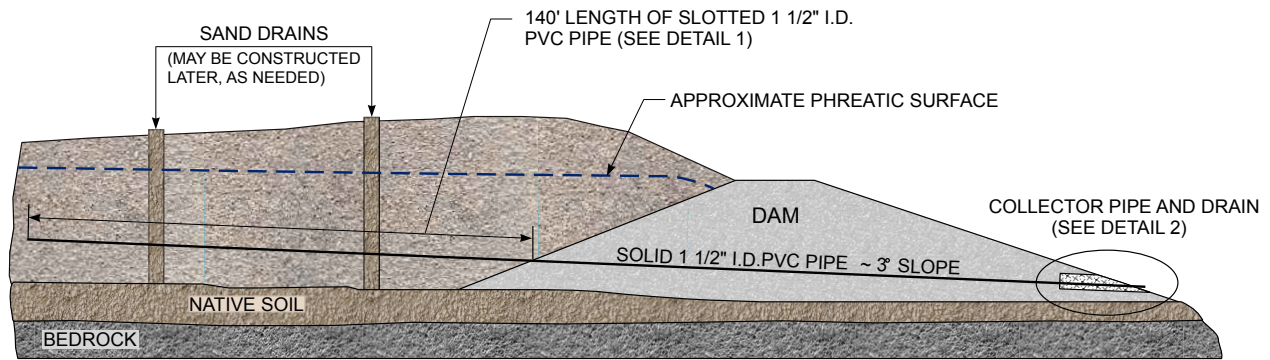

FIGURE 6.52 TYPICAL RELIEF WELL INSTALLATION

6.6.2.3.5 Horizontal Drains

Horizontal drains perform a similar function to relief wells, but provide more effective drainage either in the foundation under the main body of an embankment or within the embankment. Most often, horizontal drains are used to reduce excessive pore-water pressure within or beneath an existing embankment. A typical horizontal drain installation and details are shown in [Figure 6.53](#). Horizontal drains are normally sloped toward the discharge end.

Although horizontal drains 600 feet long and longer have been installed, lengths of 400 feet or less are more common. The drains, which are usually slotted plastic pipe, are normally installed inside steel drill rods, which are subsequently retracted. Because there is no soil filter around the slotted pipe, the slots must be sized to prevent infiltration of fines based upon the rules discussed in [Section 6.6.2.3.1](#). In some cases, porous plastic pipe has been placed around the slotted pipe to limit the infiltration of fines. The spacing required between horizontal drains is difficult to determine accurately. Pore-water pressure should be monitored with piezometers to check the performance of an installation. A system



EMBankment Cross Section

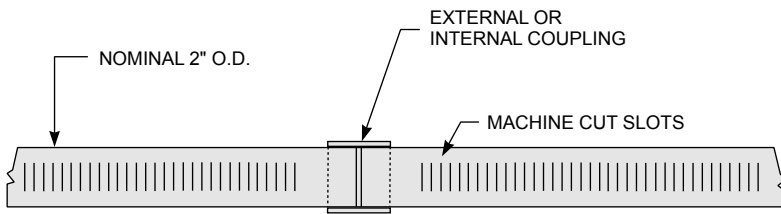

DETAIL 1 - 1 1/2" I.D. PVC PIPE WITH 0.02" MACHINE-CUT SLOTS

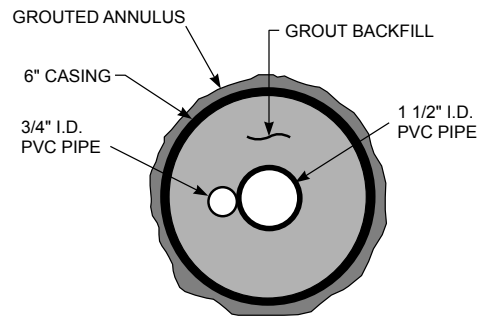

SECTION A - A (SEE DETAIL 2)

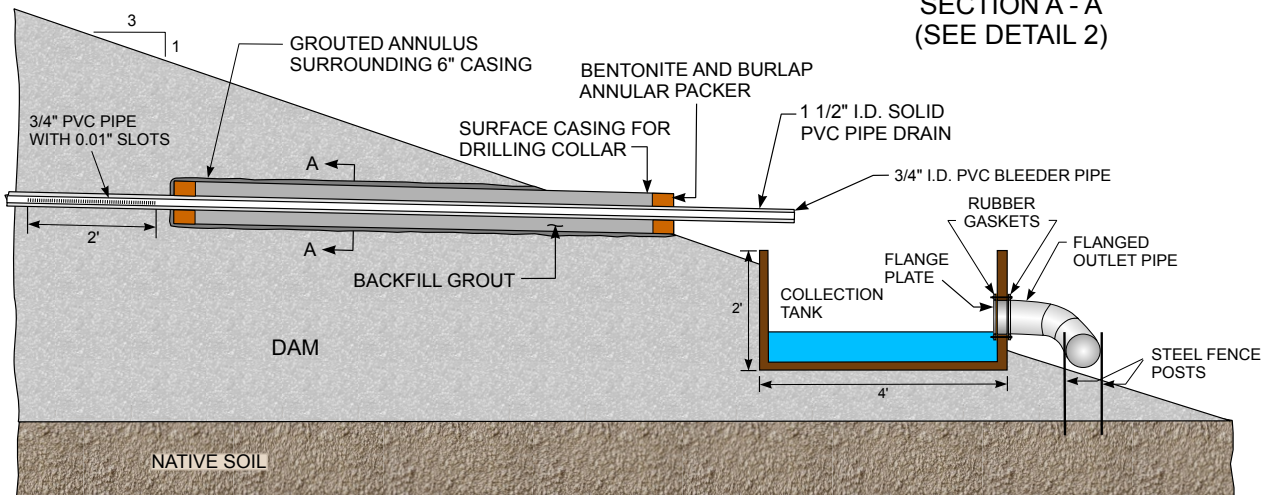

DETAIL 2 - DRAIN COLLAR AND DRAINAGE COLLECTION

FIGURE 6.53 EXAMPLE HORIZONTAL DRAIN INSTALLATION

of horizontal drains can be readily expanded if the capacity of the initial installation fails to produce the required reduction in piezometric head.

The installation of horizontal drains can be dangerous in situations where large volumes of seepage could lead to a piping failure at the drain borehole during installation. Horizontal drain systems should be installed by an experienced contractor under expert supervision.

6.6.2.3.6 Impoundment Liners

To protect the groundwater some state agencies may require that seepage from fine coal refuse be limited. This can be accomplished by using a layer of low-hydraulic-conductivity soil or geomembrane liners. Geomembranes are manufactured, low-hydraulic-conductivity synthetic materials that function as barriers to liquids and vapors. When used as a liner on the bottom and sides of a refuse disposal impoundment, a geomembrane can impede leachate migration from overlying refuse into the underlying soil and groundwater and can be used to collect the leachate for treatment. When a geomembrane is used as a cap in the final cover over the impoundment, it prevents precipitation from infiltrating the coal refuse, thus minimizing or eliminating leachate generation.

Minimum requirements for geomembrane liners are often specified in state regulations. Minimum strength properties are provided in Table 6.51. However, if the application is on a slope or there is a possibility that differential settlement could occur, increasing stress and strain on the geomembrane, a more conservative choice of membrane thickness may be appropriate. The strength of the liner is usually reduced at seams. Standard tests for shear and peel strength should be performed on both factory and field seams. A determination must be made as to the minimum percentage of geomembrane material strength that the seam itself must possess. This minimum seam strength criterion is typically incorporated into the quality assurance/quality control (QA/QC) program for liner installation. For evaluation of survivability, the minimum seam strength should be determined early in the design stage if it is likely that the geomembrane will be subjected to ultraviolet radiation for a significant period of time. If that is the case, a material with a high resistance to ultraviolet light deterioration should be used.

TABLE 6.51 RECOMMENDED MINIMUM PROPERTIES FOR GENERAL GEOMEMBRANE INSTALLATION SURVIVABILITY

Property and Test Method		Required Degree of Survivability			
		Low ⁽¹⁾	Medium ⁽²⁾	High ⁽³⁾	Very High ⁽⁴⁾
Thickness – ASTM D 1593	(mils)	20	25	30	40
Tensile – ASTM D 882 (1-in strip)	(lb/in)	30	40	50	60
Tear Resistance – D 1004 (Die C)	(lb)	5	7.5	10	15
Bursting Strength – D 3787	(lb)	20	25	30	35
Impact Resistance – D 3998	(ft-lb)	10	12	15	20

- Note:
1. Low refers to careful hand-placement on very uniform, well-graded subgrade with light loads of a static nature – typical of vapor barriers beneath building floor slabs.
 2. Medium refers to hand- or machine-placement on machine-graded subgrade with medium loads – typical of canal liners.
 3. High refers to hand- or machine-placement on machine-graded subgrade of poor texture with high loads – typical of landfill liners and covers.
 4. Very high refers to hand- or machine-placement on machine-graded subgrade of very poor texture with high loads - typical of reservoir covers and liners for heap leach pads.

(ADAPTED FROM KOERNER, 2006)

6.6.2.3.7 Foundation Seepage Cutoffs

In addition to measures to control seepage in embankments, foundation treatments such as cutoff trenches backfilled with compacted low-hydraulic-conductivity materials are also routinely incorporated into refuse facility designs. Foundation cutoff trenches are discussed in [Section 6.3](#).

6.6.2.3.8 Impoundment Water and Slurry Deposition Management

Management of impoundment water and slurry deposition at a coal refuse disposal facility are operational measures for controlling and mitigating the effects of seepage. Maintenance of a low level of clarified water in an impoundment reduces the hydraulic head and the source volume for seepage through the embankment. Additionally, deposition of coal refuse slurry at or near the upstream embankment face and the resulting build up of a delta of fine refuse against the embankment will reduce seepage into the embankment if the fine refuse has a lower hydraulic conductivity than the embankment material. To develop and maintain an effective fine refuse delta across the upstream face of the embankment, periodic relocation of the slurry discharge point or use of multiple discharge points may be required. At some facilities, small cells have been constructed near the upstream end of a refuse impoundment for storage of water for recirculation to the preparation plant. Such provisions reduce the likelihood of water being impounded directly against a coarse refuse embankment and associated seepage concerns.

6.6.2.4 Seepage Measurements

When seepage rates or piezometric levels are an important factor in the performance of a disposal facility, estimates of the phreatic surface, magnitude and rate of dissipation of pore pressures, and quantity of seepage collected in internal drains should be made. These predictions should be checked during and after construction by instrumenting the refuse embankment (and foundation if necessary) and measuring changes in the phreatic surface and pore pressures. Procedures for monitoring groundwater levels and pore-water pressures are discussed in Chapter 13. Field piezometer data provide a basis for updating performance predictions and for possible modification of design or construction procedures. Weirs or parshall flumes at the outlets of internal drains can be used to measure the seepage collected from an embankment for comparison to results of seepage analyses associated with the internal drain design. In addition, instrumentation can provide a check on the in-situ embankment hydraulic conductivity, as compared to that assumed in the analyses and/or determined by laboratory or field hydraulic conductivity tests. Monitoring of seepage conditions is also important for detection of unanticipated changes in the saturation level or seepage quantity and can provide an early indication of a problem such as clogging of an underdrain.

6.6.3 Settlement Analysis

6.6.3.1 Conditions Requiring Deformation Analysis

Settlement of a coal refuse embankment occurs as a result of embankment compression, foundation compression, plastic deformation, differential settlements, mine subsidence or a combination of these effects. Settlement is usually important if an embankment will impound water or if it will serve as the foundation for future construction. The design of any impounding embankment must limit settlement of the crest so that the freeboard is not reduced below the allowable limit. Embankments should be cambered so that the crest is elevated relative to the abutments to compensate for the increased settlement that typically occurs near the center of the embankment where the foundation overburden and embankment height are the greatest. It is also important that the embankment does not settle so much that the hydraulic conductivity characteristics of the embankment are significantly changed or the potential for piping or internal erosion due to cracking is created. Embankment and foundation settlement can also affect the performance and structural integrity of conduits and other structures. The settlement that can be tolerated by a structure depends upon its function.

The magnitude of settlement under self-weight experienced by a coal refuse embankment cannot be accurately estimated from fundamental stress-strain properties. The most useful information for computing embankment settlement is performance data from instrumented earth and rockfill dams. These data indicate that settlement of well-compacted earth dams due to embankment compression ranges from less than 1 percent for dams constructed of non-plastic soils to more than 4 percent for dams constructed of highly-plastic, fine-grained soils. Measured settlements of rockfill dams have ranged from essentially no settlement for well-compacted and sluiced rockfill placed in thin lifts to 10 percent or more for unsluiced rock placed in thick lifts. Therefore, the amount a coal refuse embankment will settle due to compression can range from 1 percent or less for well-compacted materials to 8 to 10 percent for uncompacted materials. However, a coal refuse embankment is often constructed over 20 to 30 or more years, as compared to one to three years for an earth or rockfill dam. Thus, nearly all coal refuse embankment settlement will likely occur during construction, and additional settlement after abandonment will be minimal.

If an embankment foundation consists of dense glacial till, dense sand and gravel, or rock, it will deform only slightly under the weight of the embankment because, at the stress levels experienced, both the foundation materials and any existing pore-water are essentially incompressible. Thus, settlement of such embankments due to foundation settlement will be minimal. If the foundation consists of saturated fine-grained soils, there may be significant settlement from consolidation due to the time-dependent expulsion of pore water from the soil. In such cases, the development of excess pore-water pressures can also affect foundation stability and these excess pressures need to be taken into account in embankment stability analyses.

Upstream construction of coal refuse disposal embankments over fine coal refuse deposits typically results in consolidation settlements that can give rise to elevated pore pressures if construction occurs rapidly. To prevent localized instability, construction procedures should be carefully planned. Monitoring of pore pressure may be needed as part of monitoring of embankment stability and controlling the rate of construction. These issues are discussed in Chapter 11.

Consolidation occurs slowly, sometimes over several months or years. Consolidation settlement can be a very important design factor because, in addition to causing damage to drainage pipes and structures, it can affect aspects of the entire disposal facility. Problems created by consolidation may not become apparent until after the disposal facility begins operation, at a time when the settlement could create a safety hazard and when corrections are most expensive. If consolidation is associated with embankment construction over soft clay deposits, the total settlement could be substantial. When a slurry impoundment is to be eliminated by backfilling the remaining reservoir, the settlement of the cap material must be considered in the design. Sufficient cap material must be placed such that following long-term settlement positive surface drainage will be maintained and a depression that will collect water is not created.

The magnitude of the foundation consolidation settlement depends on the weight of the embankment, the depth and thickness of the compressible strata in the foundation, and the compression indices of these compressible strata. Compression indices can be obtained from laboratory consolidation tests on undisturbed samples taken from the compressible strata. Compression indices from field settlement records for other disposal facilities underlain by similar compressible strata with similar moisture contents and index properties can also be used to predict the potential range of settlement.

The rate at which settlements occur is a function of the rate of change in vertical stress (directly proportional to the rate of construction), the hydraulic conductivity of the compressible material, and the drainage characteristics of the foundation. The rate of settlement is much more difficult to estimate than the magnitude of settlement. Computations based on laboratory consolidation test data may be

inaccurate because the rate at which foundation settlements occur is often controlled by minute geological characteristics that may not be detected even by carefully conducted foundation studies.

Consolidation and conventional laboratory tests used for measuring the consolidation characteristics of a soil are discussed in [Section 6.5.6](#).

Plastic deformation of an embankment and its foundation represents only a portion of the observed settlement at a coal refuse embankment. Plastic deformation is the lateral spreading of an embankment at the base coincident with settlement. Although difficult to determine, it is important to allow for the amount of plastic deformation that will occur because it can cause extension of pipes constructed through the embankment. Although the magnitude of such an extension may be as much as several percent of the total length of the pipe, damage can usually be avoided if the extension occurs uniformly over the length of the pipe. However, if the extension is concentrated or if the pipe cannot tolerate significant extension, it may separate and leak or fracture and collapse. Such an outcome could seriously affect embankment stability. To minimize the risk of this type of failure, pipes should either be placed in the foundation below the plastic zone or should be designed to tolerate the anticipated extension.

Differential vertical settlements can also cause damage to a coal refuse embankment and to interior structures. Differential foundation settlements, particularly if they occur over small distances, can result in embankment cracks and lead to subsurface erosion. Differential settlements can also cause damage to pipe drains and decant lines installed within or beneath an embankment. When considering the potentially damaging effects of foundation settlements beneath a planned coal refuse embankment, it should be assumed that some areas of the foundation may have localized settlements at least twice as great as the predicted overall settlement. Therefore, if substantial foundation settlements are expected, placing pipelines within or beneath an embankment should be avoided. If a decant pipe is placed in an embankment, it should be located as far as possible from the areas where the settlement is anticipated to be greatest.

Embankments constructed above or adjacent to underground mine voids can experience settlement and lateral distortion caused by subsidence. Depending on the characteristics of the overburden rock, the depth and type of mining, and whether the mining is pre-existing or is occurring during disposal operations, the subsidence can have a significant effect on the stability of the embankment and the retained coal refuse. Additional discussion of subsidence issues can be found in the following Manual sections:

- [Section 5.4](#) for mine subsidence considerations during facility design
- [Section 8.4](#) for analysis of mine subsidence
- [Section 8.5](#) for mine breakthrough potential evaluations

Sherard (1973) reports that earth dam cores of almost all soil types have experienced cracking. Therefore, designers should carefully consider the surface topography in which, and the foundation condition and materials on which, the embankment will be constructed. For dams in narrow valleys, cracking patterns such as those shown in [Figure 6.54](#) have been observed. Transverse vertical cracks often develop within about 15 to 50 feet from the end of the crest, and in the central portion where the embankment is the highest, vertical cracks often develop on or near the crest, as shown in [Figure 6.54](#).

Based on the results of laboratory testing reported by Leonards and Narain (1963) and statistical evaluation of earth dam performance by Biarez et al. (1970) and Londe (1970), as reported by Sherard (1973), the tensile strain at which first cracking occurs is in the range of 0.1 to 0.3 percent. In most of these case histories, the embankments were placed with a moisture content from 1 to

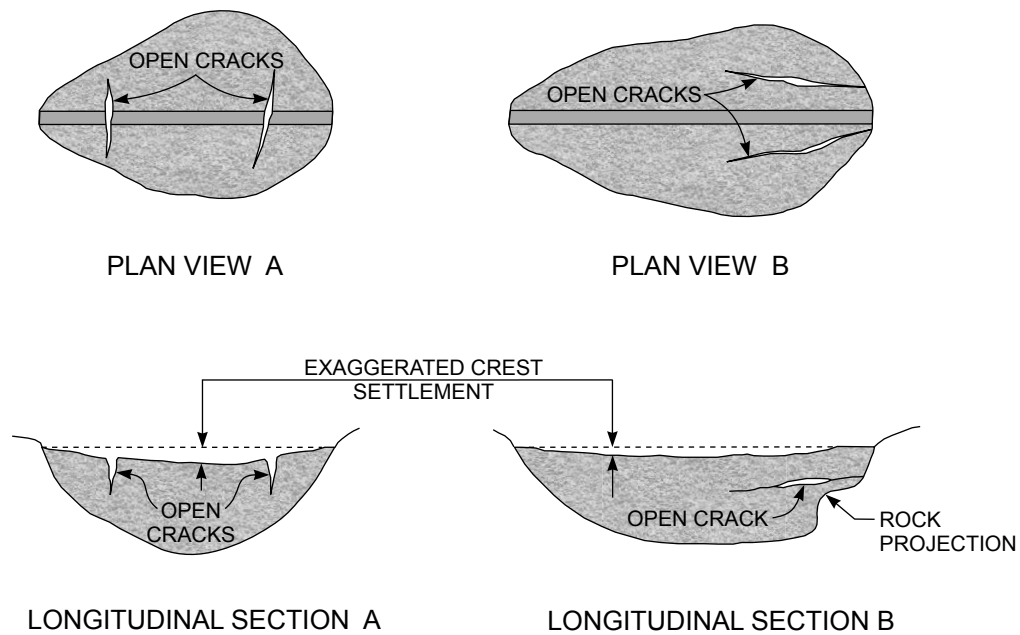

(FELL ET AL., 2005)

FIGURE 6.54 CRACKING PATTERNS OBSERVED FOR DAMS IN NARROW VALLEYS

4 percent dry of optimum (Wilson and Squier, 1969). Tensile strains in earth dams should be considered, and precautionary measures to limit the magnitude of tensile strains should be incorporated, as necessary. Precautionary measures could include: (1) incorporating more crack resistant soils in the dam cross section where cracking is most likely, (2) taking added care in foundation preparation to avoid/minimize large changes in foundation grades, or (3) increasing the width of the embankment cross section. Regardless, designers should assess the potential effects of factors that can cause differential settlement and incorporate appropriate measures to limit the development of cracks during construction and long-term operations.

Broadly-graded coarse coal refuse, placed at or above optimum moisture content and at relatively low construction rates that allow settlement to occur as fill is gradually added, is generally considered to be less susceptible to cracking than earthen materials, which are frequently subject to longer-term consolidation, after completion of construction.

6.6.3.2 Settlement and Deformation Analysis

Embankment and foundation settlement and deformation are typically evaluated using principles of elastic behavior and/or Terzaghi consolidation theory. For most settlement and deformation analyses associated with coal refuse disposal facilities, stresses in foundations and embankments and changes in stress due to load application (e.g., embankment loading on the foundation) can be estimated using elastic theory. Closed-form equations and graphical methods for estimating stresses for a variety of geometric loading cases, homogeneous and layered subsurface profiles, and isotropic and anisotropic subgrade conditions are available in Poulos and Davis (1974). Methods for estimating settlement due to elastic compression and consolidation are described in numerous foundation engineering textbooks (Terzaghi et al., 1996; Hunt, 1986; Holtz and Kovacs, 1981) and design manuals (CGS, 2007; DOD, 2005).

Since the early 1970s, finite element (FE) methods that permit realistic deformation analysis of earthen embankments and foundations have been developed. As summarized by Duncan (1996), some of the special features of FE methods with application to embankments and foundations are:

- Versatile tool for analysis of stresses and movements in earth masses, including:
 - Stresses, deformations and pore pressures in embankments and foundations
 - Conditions during construction such as consolidation and embankment compression due to self-weight
 - Potential for cracking and hydraulic fracturing
- Can model nonlinear stress-strain behavior, non-homogeneous conditions, and changes in geometry such as embankment construction
- Software are available with graphical pre- and post-processors to facilitate data input and evaluate analysis results.

FE analyses require input data such as: (1) definition of the in-situ stress conditions of the foundation materials, (2) the stress-strain properties of the foundation and embankment materials, and (3) the sequence of construction.

For problems that involve a natural soil or rock deposit or an existing fill, the state of stress in the soil mass prior to the beginning of construction or loading must be specified because:

- For incremental analyses, the changes in stress calculated during each increment are added to the stresses at the beginning of the increment in order to evaluate the stresses at the end. To begin this process, it is necessary to know the initial in-situ stresses.
- The stiffness of the soil is a function of the stresses in the soil.

The in-situ stresses can be measured, but are usually estimated. For level ground where at-rest pressure conditions would be expected, the vertical stresses are usually assumed to be equal to the overburden pressure, and the horizontal stresses are assumed to be the at-rest lateral earth pressure coefficient K_0 times the overburden pressure. The value of K_0 is usually estimated based upon empirical relationships (Jaky, 1944; Mayne and Kulhawy, 1982). For initially sloping ground, one procedure that has been used is performing a gravity turn-on analysis (i.e., applying vertical forces representing the weight of the material to an initially unstressed mesh) and then changing the horizontal stresses to K_0 times the calculated vertical stresses.

The stress-strain properties of modeled materials play a critical role in finite element analyses. For most deformation analyses of embankments and foundations where constituent materials are not stressed close to failure and strains are small, stress-strain behavior can be represented by a linear elastic model. However, for rock foundations, the modulus should reflect the deformation characteristics of the rock mass through modification of the deformation of intact (i.e., unfractured) rock using a rock mass classification system such as that proposed by Bieniawski (1989). The Bieniawski geomechanics classification system involves modification of the modulus of intact rock as determined from unconfined compression tests (Section 6.5.9.2) using the following relationship:

$$E_m = 2 RMR - 100 \quad (6-29)$$

where:

E_m = modulus of the rock mass (force/length²)

RMR = rock mass rating; this parameter accounts for the effects of intact rock strength, rock quality designation (RQD), joint spacing, joint condition, joint orientation and groundwater (dimensionless)

RMR increases with rock quality with a range from 0 to 100. Equation 6-29 is valid for $RMR \geq 55$. For softer rocks, the following relationship, which was proposed by Serafim and Pereira (1983), can be used:

$$E_m = 10^{(RMR-10)/40} \tag{6-30}$$

For soils it is often necessary to use stress-strain relationships that account for nonlinear behavior and the variation of soil modulus with confining pressure. Table 6.52 summarizes the types of stress-strain models typically used and their respective advantages and limitations.

TABLE 6.52 STRESS-STRAIN RELATIONSHIPS USED FOR FINITE ELEMENT DEFORMATION ANALYSES OF EMBANKMENTS AND FOUNDATIONS

Stress-Strain Relationship	Advantages	Limitations
Linear Elastic	Simplicity	Can only model real soil behavior at low stress levels and small strains
Multi-linear Elastic	Can model any shape stress-strain curve for ductile materials	Must be developed on a case-by-case basis to approximate stress-strain behavior
Hyperbolic	Can model nonlinear behavior; parameters have physical significance and can be evaluated by triaxial testing	Inherently elastic; does not model plastic deformations in a fully logical manner

(ADAPTED FROM DUNCAN, 1996)

Analyses should simulate as closely as possible the actual construction or loading sequence associated with the structure being analyzed. This can be accomplished by adding elements to simulate fill placement, removing elements to simulate excavation, and applying loads in increments. Other processes that can be modeled in FE analyses include raising or lowering phreatic levels and consolidation.

Comparison of the results of FE analyses with field measurements shows there is a tendency for calculated deformations to be larger than measured deformations. Duncan (1996) offered the following reasons for this difference:

- Soils/materials in the field tend to be stiffer than laboratory test samples at the same density and moisture content due to aging effects.
- Average field densities are higher than the specified minimum dry density, which is often used as the target for preparing samples for laboratory testing.
- Soils/materials sampled in the field for laboratory testing are disturbed by the sampling process.
- Most field conditions approximate plane strain whereas triaxial tests are routinely used for laboratory characterization.
- 2D finite element analyses overestimate deformations of embankments constructed in V-shaped valleys with steep walls.

Analysis of embankments using the FE method has demonstrated the considerable potential of the approach and has identified the sources of uncertainty that engineers should be aware of. These uncertainties are primarily associated with difficulties in accurately predicting the in-place density and moisture content of soils/materials in the field and difficulties anticipating the sequence of operations that will be followed during construction.

6.6.3.3 Deformation Control Measures

In a slurry impoundment, fine coal refuse typically has a low unit weight (as compared to typical soils), low hydraulic conductivity and low coefficient of consolidation. It is placed by peripheral discharge of low-solids-content slurry, either by single-point discharge or using multiple discharge locations. Because of this method of placement, fine coal refuse tailings can be very soft and susceptible to long-term settlements.

The rate of consolidation at existing refuse disposal sites can be expedited by the installation of pre-fabricated vertical (PV) drains into the tailings at close vertical spacing to drain excess pore-water pressures. PV drains consist of a high-flow polymeric core wrapped in a non-woven geotextile. The drains are installed using static, vibratory or jetting methods. Guidelines for the engineering design of PV drains are presented in Rixner et al. (1986). Brown and Greenaway (1999) describe instances where PV drains were used to expedite consolidation of uranium mill tailings before construction of a clay cap required for abandonment. Prefabricated drains have also been placed horizontally on the surface of a coal refuse impoundment prior to upstream construction to speed consolidation and dissipation of pore pressures (Thacker et al., 1988). The effectiveness of the drain installations was demonstrated by the control of pore pressures and consolidation. Drilled horizontal drains have also been used to lower pore-water pressures in tailings impoundments.

Drainage measures to accommodate dissipation of pore pressures and to consolidate fine materials such as fine coal refuse can be incorporated into facility design, as discussed in Section 6.3.

Adaptations of shallow and deep soil mixing technologies developed for improving loose and soft soil deposits have been used for the in-place solidification of fine coal refuse. Bazán-Arias et al. (2002) describe the use of these methods to stabilize fine coal refuse using custom-designed equipment to blend a cement/fly ash slurry with coal refuse for supporting a highway embankment over a slurry pond. QC testing of cured samples resulted in a 28-day, unconfined compressive strength greater than 100 psi and peak shear strength parameters of $\phi' > 45^\circ$ and $c' > 13$ psi.

Lime has also been used to stabilize fine coal refuse. Lime stabilization causes the refuse to behave as an overconsolidated material. However, when load is applied that exceeds the apparent maximum past consolidation pressure, the “stabilized” refuse tends to collapse and return to its previous “unstabilized” behavior. Therefore, it is recommended that potential use of lime stabilization of fine coal refuse be carefully evaluated through laboratory and field performance testing before implementation in the field.

6.6.3.4 Deformation Measurements

When predicted settlements are an important factor in the design of a coal refuse disposal facility, estimates of the magnitude and the rate of settlement should be made using sophisticated analyses with the best available data. The performance of a coal refuse disposal facility should be monitored through installation of an instrumentation system and comparison of observed data to predicted deformations. Depending on site conditions and project requirements, deformations and deformation rates can be monitored by:

- Surface monuments (vertical and horizontal displacements)
- Settlement gages and extensometers (vertical displacements)
- Inclinometers (lateral displacements in slopes)
- Piezometers (piezometric heads in the embankment and foundation)

As described in Chapter 13, instrumentation should be installed to verify that acceptable levels of performance are being achieved and to provide a check on design assumptions.

6.6.4 Slope Stability Analysis

6.6.4.1 Conditions Requiring Stability Analysis

The design of a new coal refuse disposal facility or the expansion or modification of an existing facility requires that the stability of compacted embankments and natural soil and rock slopes and foundations be assessed. The most critical cross sections and cases must be analyzed. Factors considered in selecting the most critical cross sections include: (1) slope of the embankment, (2) height of the embankment, (3) foundation conditions, (4) pore-pressure conditions, and (5) presence of lower strength material zones within the embankment/impoundment (e.g., upstream construction cross sections). Critical cross sections can include upstream or downstream embankment slopes. Important cases include the following:

- Long-term or final embankment configuration
- Intermediate stages of development that may include critical cross sections related to slope, height, foundation, embankment material properties, or phreatic levels or pore-pressure conditions
- Short-term, end-of-construction conditions for stages on soft, compressible materials
- Rapid loading of fine coal refuse deposits during initiation of upstream construction that possibly leads to an unacceptably low factor of safety against bearing failure of the fine refuse underlying the area of embankment raising
- Rapid drawdown of the impoundment
- Seismic loading and strength loss or increases in pore pressure

Phreatic levels and pore-pressure conditions should be determined on the basis of seepage analyses and, for existing facilities, by correlations with piezometric measurements.

In selecting an upstream construction cross section for analysis, the interface between the coarse refuse embankment and fine refuse deposits should be determined based on subsurface exploration (borings and cone penetration tests are recommended) if an existing facility is being analyzed. For new facilities, analysis cross sections should be determined based on staging calculations considering upstream construction procedures and fine coal refuse behavior. Staging calculations will identify the approximate level of the settled fine refuse at the initiation of upstream construction. The following facility-specific issues must be considered:

- Type of settled fine coal refuse that will support the upstream stage (e.g., sandy or clayey fine refuse)
- Presence and location of impoundment pool relative to the extent of the upstream push out
- Staging area for coarse coal refuse to be used for the push out
- Presence of excess pore-water pressures in areas where the fine refuse is not fully consolidated
- Equipment and lift thickness that can be used for the push out
- Monitoring program that can be implemented and used in controlling the push out

The behavior of fine coal refuse in response to upstream construction may include consolidation, mixing with the coarse refuse during the initial push out, and development of a zone of assimilation. Appropriate material strengths and levels of excess pore-water pressure need to be used

in analyses. Experience at similar facilities can provide valuable insight into material behavior, construction procedures to be employed, and the resulting zone of mixing. The strength in this zone of mixing should be determined based on the relative properties of the coarse and fine refuse materials at the site. In some cases, an exploration program at an existing similar facility might be undertaken for determining the desired properties. Typically, this zone of mixing does not play a significant role in the static analysis of downstream embankment slopes, but can be critical for seismic analysis and upstream slopes. The following guidance has been developed for deciding whether potential upstream failure surfaces are critical to the seismic stability and deformation of the embankment (MSHA, 2007):

- Potential upstream slope stability failure surfaces that terminate on the crest of the embankment stage should provide an acceptable factor of safety such that the integrity of the embankment and impounding capacity of the facility are maintained (i.e., if a portion of the embankment becomes unstable, a sufficient section of the crest will remain intact to prevent release from the impoundment).
- Potential deformation of the crest of the embankment should not result in the threat of a release from the impoundment (i.e., sufficient freeboard must be available to compensate for the maximum amount of crest settlement).

Another critical case where fine coal refuse characteristics are important is related to recovery or re-mining of fine coal refuse within an impoundment. This situation typically involves the development of an excavation plan with interim and final coal refuse slopes that must have acceptable factors of safety.

Additional conditions requiring slope stability analyses may arise due to situations in which the shear strength decreases or stress level in an embankment increases. Duncan and Wright (2005) cite the following causes for a decrease in shear strength:

- Increased pore pressure (reduced effective stress) due principally to a rise in ground-water level or increased seepage during periods of heavy rainfall
- Cracking near the crest of a slope due to tension and factors such as soil desiccation
- Swelling of highly plastic and heavily overconsolidated clays
- Development of slickensides due to shear in highly plastic clays resulting from shear on distinct slip planes
- Decomposition of rock in fills due to inadequate breakdown during compaction and weathering as a result of wetting and drying
- Creep of highly plastic clays under sustained load
- Leaching of chemical constituents in the soil matrix
- Strain softening of brittle soils leading to progressive failure
- Weathering of rocks and indurated soils due to physical, chemical and biological processes
- Cyclic loading and loss of strength due to liquefaction (Chapter 7)

Possible causes for an increase in shear stress include:

- Increased loads at the top of a slope
- Water pressure in tension cracks at the crest of a slope
- Increase in soil weight due to increase in moisture content

- Excavation at the bottom of a slope
- Rapid drawdown of an impoundment (upstream slope)
- Earthquake loading

Traditionally, slope stability has been evaluated using limit equilibrium analyses whereby the forces tending to decrease stability are compared to the forces tending to increase stability. These types of analyses are generally conducted using limit equilibrium slope stability computer programs. Since the early 1970s, finite element methods of analysis have improved to the point where realistic stability/deformation analysis of soil slopes is possible. The following section provides an overview of stability analyses for coal refuse disposal facility embankments.

6.6.4.2 Methods of Stability Analysis

6.6.4.2.1 Limit Equilibrium Stability Analysis

The stability of refuse embankments is usually solved by limit equilibrium methods of analysis. These analyses are conducted by calculating the minimum factor of safety (FS) for a slide surface through the slope as follows:

$$FS = \frac{\text{Available shear strength}}{\text{Equilibrium shear stress}} = \frac{s}{\tau} \quad (6-31)$$

If a large number of potential slide plane surfaces are assumed, the surface with the minimum factor of safety is a numerical representation of the relative safety of the slope. If $FS = 1$, a slope is in a state of “just-stable” limit equilibrium. Because of the uncertainty related to the geometry of the actual slide plane surface, the controlling soil properties, the pore-pressure distribution in the slope, and other factors that may affect the stability of a slope, slopes for water impounding embankments should be designed with FS equal to at least 1.5. A higher factor of safety should be used where factors that affect slope stability (e.g., limited testing has been performed) are less certain. The available shear strength (s) is defined in terms of the angle of friction (ϕ or ϕ') and cohesion (c or c') of the soil along the slide plane surface using soil properties determined from in-situ or laboratory tests.

Two approaches can be used to satisfy static equilibrium of a slope. The first and much less commonly used approach is to assume a single free-body bounded by the face of the slope and slide plane surface. Examples of this approach are the infinite slope, log spiral and Swedish slip circle methods. The second approach involves dividing the slope into a number of vertical slices that extend between the face of the slope and slide plane surface. Examples of this approach are the ordinary method of slices, simplified Bishop method and Spencer’s method. Regardless of the approach used there are more unknowns (e.g., forces, location of forces, FS) than equilibrium equations, so the problem is statically indeterminate. Therefore, assumptions must be made to render the problem determinate. Examples of such assumptions include inclination of interslice forces, the location of the normal force at the base of a slice and the relationship of interslice shear force to the interslice normal force.

Some slope stability analysis methods are based solely upon force-equilibrium principles, while other methods involve satisfaction of all conditions of equilibrium. The characteristics of various equilibrium methods for slope stability analysis are summarized in [Table 6.53](#). If force-equilibrium methods are used (Lowe and Karafiath, 1960; USACE, 2003), the factor of safety is affected significantly by the assumed inclinations of the side forces between slices. Thus, force-equilibrium procedures are not as accurate as methods that satisfy all conditions of equilibrium (Janbu, 1973; Spencer, 1967; Morgenstern and Price, 1965). The maximum range of results for methods that satisfy all conditions of equilibrium is generally less than 12 percent. Thus, with an average accuracy of about plus or minus 6 percent, a factor of safety calculated using procedures that satisfy all conditions of equilibrium can

TABLE 6.53 CHARACTERISTICS OF EQUILIBRIUM PROCEDURES FOR SLOPE STABILITY ANALYSIS

Procedure	Application
Infinite Slope	Homogeneous cohesionless slopes where stratigraphy restricts slip surface to shallow depths and parallel to slope face. Very accurate where applicable.
Logarithmic Spiral	Applicable to homogenous slopes; accurate. Potentially useful for developing slope stability charts and used in some software for design of reinforced slopes.
Swedish Circle	Applicable to slopes where $\phi = 0$ and for relatively thick zones of weaker materials where slip surface can be approximated by a circle.
Ordinary Methods of Slices (Fellenius, 1922)	Applicable to non-homogeneous slopes and $c - \phi$ soils where slip surface can be approximated by a circle. Very convenient for hand calculations, but inaccurate for effective stress analyses with high pore pressures.
Simplified Bishop (Bishop, 1955)	Applicable to non-homogeneous slopes and $c - \phi$ soils where slip surface can be approximated by a circle. More accurate than OMS, especially for effective stress analyses with high pore pressures. Calculations can be performed by hand or spreadsheet.
Force Equilibrium Methods (Lowe and Karafiath, 1960; USACE, 2003)	Applicable to virtually all slope geometries and soil profiles. The only procedure suitable for hand calculations with non-circular slip surfaces. Less accurate than complete equilibrium procedures, and results are sensitive to assumed inclination for interslice forces.
Janbu Generalized Procedure of Slices (Janbu, 1973)	Satisfies all conditions of equilibrium. Applicable for any shape of slip surface. Numerical problems are encountered more frequently than with some other methods.
Spencer (Spencer, 1967)	Satisfies all conditions of equilibrium. Accurate procedure applicable to virtually all slope geometries and soil profiles. Simplest complete equilibrium procedure for computing factor of safety.
Morgenstern and Price (1965)	Satisfies all conditions of equilibrium. Accurate procedure applicable to virtually all slope geometries and soil profiles. Rigorous, well-established complete equilibrium procedure.
Chen and Morgenstern (1983)	Satisfies all conditions of equilibrium. An updated Morgenstern and Price procedure. Rigorous and accurate procedure applicable to any slip surface shape and slope geometry, loads and soil profiles.
Sarma (1973)	Satisfies all conditions of equilibrium. Accurate procedure applicable to virtually all slope geometries and soil profiles. Convenient complete equilibrium procedure for computing seismic coefficient required to produce a given factor of safety. Side force assumptions are difficult to implement for all but simple slopes.

(DUNCAN AND WRIGHT, 2005)

be considered to be acceptably accurate, because for practical purposes key parameters such as slope geometry, unit weight, shear strength, and pore-water pressure cannot be defined with an accuracy of plus or minus 6 percent. Therefore, any method that satisfies all conditions of equilibrium should be sufficiently accurate for impoundment design and analysis. Additional information relative to selection of a slope stability analysis method can be found in Duncan and Wright (1980).

For slopes composed of nearly homogeneous materials, both analysis and observation of actual failures indicate that the failure surface can be approximated with sufficient accuracy by a circular arc. For such cases, procedures that do not satisfy all conditions of equilibrium may be acceptably

accurate. For non-homogeneous slopes or embankments, embankments supported on a foundation with a weak zone and impoundments lined with geomembranes or geosynthetic clay liners, limit-equilibrium procedures that are suitable for any shape slip surface and that satisfy all conditions of equilibrium must be used. Designers should be especially alert to the presence of a weak layer or layers upon which sliding may occur. In such cases, the factor of safety for wedge-type surfaces coincident with the weak layer must be evaluated in addition to the usual failure surfaces. If movement has already occurred in a zone of material that is included in a stability analysis, then residual shear strength may be applicable.

An implicit assumption in equilibrium analyses of slope stability is that the stress-strain behavior of the constituent material is ductile (i.e., it does not have a brittle stress-strain curve where the shearing resistance drops off after reaching a peak). This limitation results from the fact that limit-equilibrium methods provide no information regarding the magnitudes of the strains within a slope, nor any indication about how they may vary along the slip surface. Therefore, unless the strengths used in the analysis can be mobilized over a wide range of strains (i.e., the soil exhibits ductile stress-strain behavior) there is no guarantee that the peak strength can be mobilized simultaneously along the full length of the slip surface. Where multiple embankment or impoundment zones are traversed by the slip surface, strain compatibility for each material should be evaluated. For instance, coarse coal refuse typically mobilizes peak strength at a lower strain than fine coal refuse and cohesive foundation soils. Thus, the stability analysis should be based on strength at compatible strains, particularly if there is a drop-off in strength with large strains. If the shearing resistance of one material drops off after the peak is reached, progressive failure can occur, and the shearing resistance that can be mobilized at some parts of the failure surface may be smaller than the peak strength. For this situation, a reliable approach is to use the residual strength rather than the peak strength in the analysis.

For coal refuse, earth and rockfill embankments, the following critical embankment conditions should be evaluated:

1. High pore-water pressures are present in both the embankment and foundation. This condition occurs most often during or at the end of construction, particularly if construction is rapid, the slope materials have low hydraulic conductivity, and construction conditions are wet. For a coal refuse embankment, the rate of construction usually is not fast enough to cause high pore pressures in the foundation materials. An exception is when a thick layer of saturated clay underlies the embankment. For this case pore pressures during construction should be estimated, and piezometers should be installed to facilitate maintaining pore pressures within acceptable limits during construction. The rate of construction can also be an issue if an upstream construction pushout is constructed rapidly. Stability checks may be required both during construction and at the end of construction when an embankment is constructed over settled fine refuse using the upstream method.
2. Steady seepage has developed within the embankment and may have saturated a large part of the downstream slope. This condition occurs most often after long-term operation of an impounding embankment at full storage level, particularly if the slope materials had a high hydraulic conductivity. For compacted embankments, placement of refuse is usually slow enough that excess pore pressures will adequately dissipate. For situations where wet materials are placed in thick lifts, (e.g., filter cake or combined refuse in upstream embankment zones) excess pore pressures can develop, although generally the rate of construction is slow enough that the excess pore pressures will dissipate. Some slurry impoundments are designed to

store the runoff from the design storm and release it relatively slowly. In such cases, the water level may rise above the level of the slurry delta and be in direct contact with relatively permeable upstream slope material. If storm water is impounded against the upstream slope long enough for steady-state pore-water pressures to develop, this condition could represent a critical stability scenario.

3. The impoundment water level drops very quickly after steady seepage has developed within the embankment. This condition is generally referred to as rapid draw-down and can be critical to the stability of the upstream slope of the embankment. USBR (1987a) provides general guidance for water-detention and storage dams considering susceptibility of earth fill materials (based on USCS classification) to rapid drawdown loading (drawdown rate of 6 inches or more per day following prolonged storage at high reservoir levels). For most coal refuse embankments that impound slurry and runoff water, rapid drawdown is either not possible or is not an issue because the embankment material is generally free draining. For embankments constructed of low-hydraulic-conductivity material (less than 10^{-4} cm/sec) and designed to store storm runoff for subsequent release through a decant pipe, the potential effects of rapid drawdown should be considered. Another situation where rapid drawdown may need to be considered is during re-mining of an impoundment for recovery of additional coal from the fine coal refuse.
4. The embankment is subjected to earthquake loading during embankment construction, operation, or following abandonment. Issues related to the analysis and design of embankments that are subjected to earthquake loading are discussed in Chapter 7.

Analyses for the first three critical stability conditions listed above must reflect the rate of construction and pore-pressure conditions. The following analyses are typically employed:

- Total-Stress Analysis is used in situations where the pore-water pressure (u) that would act on the potential failure surface at failure is unknown and cannot be reliably estimated. The embankment stability is analyzed in terms of total stress (i.e., the stress between the individual soil grains plus the pore pressure). This method of stability analysis is generally considered most appropriate for evaluating relatively short-term loading conditions such as end-of-construction and rapid drawdown of the impoundment.
- Effective-Stress Analysis is used in cases where the pore-water pressure (u) that would act on the potential failure surface at failure is known or can be reliably estimated. The embankment stability is analyzed in terms of effective stress (i.e., the total stress minus the pore pressure). This method of stability analysis is generally considered most appropriate for evaluating long-term conditions after the transient effects related to construction and seepage have ended.

Selection of the appropriate conditions for analysis requires knowledge of soil behavior under drained and undrained conditions and evaluation of the conditions that will control drainage in the field. Shear strengths, water and pore pressures, and unit weights for slope-stability analyses are summarized in [Table 6.54](#).

A useful guide for determining whether total- or effective-stress methods of analysis are applicable relates to whether the soils comprising the foundations and refuse embankment are free draining or impermeable. Free-draining soils are those able to drain completely during the construction or loading period. Impermeable soils are those that cannot drain completely during the construction or

TABLE 6.54 SHEAR STRENGTHS, WATER PRESSURES, AND UNIT WEIGHTS FOR SLOPE-STABILITY ANALYSES

Soil Type	Parameter	Condition		
		End-of-Construction	Multi-stage Loading ⁽¹⁾	Long-Term
All soils	External Water Pressures	Include	Include	Include
All soils	Unit weights	Total	Total	Total
Free-draining	Shear Strength	Effective stress c' and ϕ'	Effective stress c' and ϕ'	Effective stress c' and ϕ'
Free-draining	Internal Pore Pressures	u from steady-state seepage analyses	u from steady state seepage analyses	u from steady state seepage analyses
"Impermeable"	Shear Strength	Total stress c and ϕ from in-situ or UU or CU lab tests	Total stress c and ϕ from in-situ or UU or CU lab tests	Effective stress c' and ϕ'
"Impermeable"	Internal Pore Pressures	No internal pore pressures, set $u = 0$ in computer input	No internal pore pressures, set $u = 0$ in computer input	u from steady state seepage analyses

Note: 1. Multi-stage loading includes rapid drawdown, staged construction, and any other condition where a period of consolidation under one set of loads is followed by a change in load under undrained conditions.

(DUNCAN, 1996)

loading period. Duncan (1996) recommends using the dimensionless time factor T from consolidation theory to estimate the degree of drainage that can occur during construction or loading using the relationship:

$$T = c_v t / D^2 \quad (6-32)$$

where:

c_v = coefficient of consolidation (length²/time)

t = time

D = drainage path (length)

If $T > 3$, the material can be treated as drained. If $T < 0.01$, the material can be treated as undrained. If $0.01 < T < 3$, both drained and undrained conditions should be evaluated. Duncan (1996) suggests that, if the data needed to calculate T are not available, soils with hydraulic conductivity $k > 100$ feet/year can be considered drained and soils with $k < 0.1$ foot/year can be considered undrained.

Undrained conditions should be analyzed in terms of total stress in order to avoid having to rely on estimated, and sometimes unreliable, pore pressures for undrained loading conditions. Undrained strength can be determined using in-situ tests (e.g., vane shear), UU triaxial tests, or CU tests in conjunction with a strength normalizing procedure such as the SHANSEP (stress history and normalized soil engineering parameters) procedure (Ladd and Foott, 1994). For multi-stage construction (e.g., upstream pushouts), the undrained strength can be estimated using CU triaxial test results together with values of consolidation pressure determined from consolidation analyses (Ladd, 1991).

Drained conditions can be analyzed in terms of effective stresses using c' and ϕ' from drained triaxial or direct shear tests or from \overline{CU} tests. Direct-shear or \overline{CU} tests are more often used when testing clays,

TABLE 6.55 GUIDELINE FRICTION VALUES AND EFFICIENCIES FOR VARIOUS GEOSYNTHETIC AND SOIL COMBINATIONS

Soil-to-Geomembrane Friction Angle				
Geomembrane	Soil Types			
	Concrete Sand ($\phi = 30^\circ$)	Ottawa Sand ($\phi = 28^\circ$)	Mica Schist Sand ($\phi = 26^\circ$)	
PVC				
Rough	27° (0.88) ⁽¹⁾		25° (0.96)	
Smooth	25° (0.81)		21° (0.79)	
CSPE	25° (0.81)	21° (0.72)	23° (0.87)	
HDPE	18° (0.56)	18° (0.61)	17° (0.63)	
Geomembrane-to-Geotextile Friction Angle				
Geotextile	Geomembrane			
	PVC		CSPE	HDPE
	Rough	Smooth		
Nonwoven, Needle-Punched	23°	21°	15°	8°
Nonwoven, Melt-Bonded	20°	18°	21°	11°
Woven, Monofilament	11°	10°	9°	6°
Woven, Slit Film	28°	24°	13°	10°
Soil-to-Geotextile Friction Angle				
Geotextile	Soil Types			
	Concrete Sand ($\phi = 30^\circ$)	Ottawa Sand ($\phi = 28^\circ$)	Mica Schist Sand ($\phi = 26^\circ$)	
Nonwoven, Needle-Punched	30° (1.00)	26° (0.92)	25° (0.96)	
Nonwoven, Melt-Bonded	26° (0.84)	–	–	
Woven, Monofilament	26° (0.84)	–	–	
Woven, Slit Film	24° (0.77)	24° (0.84)	23° (0.87)	

Note: 1. Efficiency values in parentheses are based on the relationship $E = \tan \delta / \tan \phi$

(ADAPTED FROM KOERNER, 2006)

because the time required for testing is shorter than for conducting CD tests. Values of c' and ϕ' from \overline{CU} tests have been found to be nearly identical to values obtained from drained tests. Values of ϕ' for natural deposits of cohesionless soils are usually estimated using correlations with SPT or CPT data.

In performing embankment stability analyses, the strength behavior of coal refuse must be carefully evaluated. There is evidence that the failure strength envelope of coarse refuse has considerable curvature in the stress range associated with high embankments due to crushing of the refuse particles. Thus, the cohesion and friction angle of the coal refuse may vary depending upon location in the embankment. Application of a bi-linear failure model may be appropriate for such cases.

For sites where impoundments are lined with geomembranes or geosynthetic clay liners (GCLs) to control seepage, the potential for slope failure between the liner and subgrade and between the liner and soil cover placed over the liner may need to be evaluated. Table 6.55 provides guideline friction angles that may be appropriate for preliminary design for various interfaces. However, final design should be based on more refined published data and manufacturers' information for the specific geosynthetic materials under consideration, as well as laboratory interface testing between on-site soils and selected geosynthetic materials to simulate site-specific conditions.

When GCLs are used on slopes, their friction properties are important. Sodium bentonite, which is often used in GCLs, is a clay with a saturated, drained residual internal angle of friction of approximately 6° to 9° . However, significantly greater friction angles may be appropriate in GCLs that are needle-punched or stitched. Manufacturers should be consulted for design data, as these data may be product specific.

An important part of slope stability analysis is determining the slip surface with the lowest FS . Most computer programs that use an assumed circular failure surface systematically change the position of the center of the circle and the length of the radius to find the most critical (lowest FS) circle. For more complex geometries typical of most real-world situations, local minima may exist. Therefore, multiple searches should be conducted using multiple starting points and search strategies so that the overall minimum value of FS is determined. The results of slope stability analyses should be carefully examined to verify that the upstream and downstream limits of the search are not so restrictive as to exclude potentially critical failure surfaces. Locating a critical noncircular surface is more complex, and a variety of approaches have been developed. Methods such as random generation of kinematically admissible slip surfaces, coupled dynamic programming minimization techniques, and optimization have been used successfully to model slopes that do not have extremely complicated geometries. Regardless of the computational procedure used, tests of reasonableness should be applied to the results, and multiple searches should be performed to be certain that the critical slip surface has been located. Failure surfaces through weaker embankment or foundation layers should always be considered.

Most slope stability problems can be modeled in two dimensions because the geometry of a slope is typically relatively constant along its length. However, some slopes are: (1) curved in plan or contain corners (e.g., some diked embankments), (2) subjected to loads of limited extent at the top, or (3) constrained by physical boundaries such as a dam in a narrow-walled valley. For these situations, consideration may be given to conducting a three-dimensional (3D) limit-equilibrium analysis. Duncan (1996) reports that the factor of safety for 3D analysis is greater than the factor of safety for 2D analysis (i.e., $FS_{3D} > FS_{2D}$) provided that: (1) FS_{2D} is calculated for the most critical two-dimensional cross section of the slope and (2) the procedure used for 2D limit-equilibrium analysis satisfies all conditions of force and moment equilibrium. If 2D analyses of refuse embankment stability meet these criteria, a 3D analysis is not generally warranted.

Some limit-equilibrium computer programs include features that permit a probabilistic analysis of slope stability. Some common characteristics of these programs include:

- Simulation techniques (e.g., Monte Carlo) that allow the program to repeatedly sample values from probability distributions of the uncertain variables
- Modeling of input parameters as random variables (e.g., material properties, phreatic surface location, seismic load coefficient)
- Defining the probability density function of the random variables in terms of statistical distributions commonly used in geotechnics (e.g., normal, exponential, lognormal)

- Using truncated distributions to define maximum and/or minimum values
- Defining correlation coefficients between correlated values (e.g., c and ϕ)
- Presentation of results in a variety of forms (e.g., histograms, cumulative plots, scatter plots)

Thus, probabilistic slope stability analysis accounts for variability and uncertainty associated with traditional limit-equilibrium methods. Figure 6.55 illustrates the results of a stability analysis of a cohesive soil slope using Spencer's method. The figure shows a histogram of frequency distribution of the FS computed for 5,000 random analyses. The red bars at the left of the distribution represent analyses where FS is less than 1. From the histogram, the mean $FS = 1.072$, and the maximum and minimum FS are 1.298 and 0.860, respectively. However, Figure 6.55 illustrates another advantage of probabilistic analysis. The ratio of the 658 analyses where FS is less than 1 to the 5,000 total analyses is the probability of failure p_f . For this analysis, $p_f = 13.2$ percent, which provides a measure of the potential for failure separate from the factor of safety. For this case, the analysis shows that a low average FS results in a high probability of failure.

Note that no value of p_f is recommended for design of embankment dams at the time of publication of this Manual, although proposed risk evaluation criteria and guidelines for significant- and high-hazard-potential dams are available (Von Thun, 1996). El-Ramly et al. (2003) present a probabilistic stability analysis of a tailings dike along with a general spread sheet model, and they note that computed values of p_f for existing dams demonstrating satisfactory performance may not meet recommended values. However, a probabilistic analysis is useful in understanding the contribution of parameters affecting stability and in comparing conditions and configurations for establishing reliable design. Probabilistic acceptance criteria will become established as more analyses are conducted and results published for both failed and satisfactorily performing slopes.

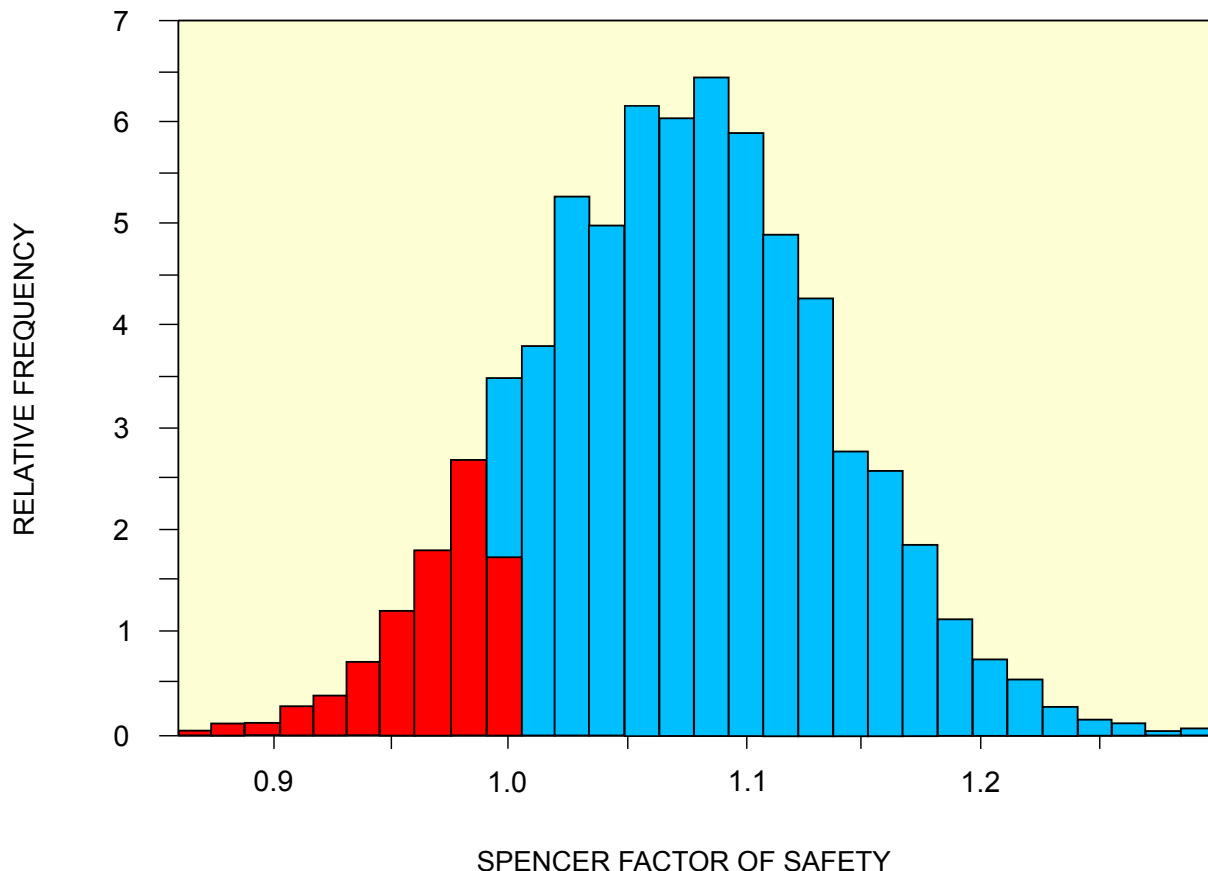

FIGURE 6.55 HISTOGRAM OF FACTOR OF SAFETY DISTRIBUTION

Additional information relative to probabilistic methods for the stability analysis of slopes is provided in Hoek (2000) and Baecher and Christian (2003).

6.6.4.2.2 Stability/Deformation Analysis Using Finite Element Methods

Slope stability analyses are traditionally performed using classical techniques such as the method of slices. These approaches are based on the assumption of rigid-plastic stress-strain behavior with no deformation occurring prior to failure. However, if elastic deformations occur prior to failure, the finite element method can be used to solve the elastic differential equations, with failure defined by placing a limit on stresses using the Mohr-Coulomb (typical) or other failure criterion. The stress-strain behavior of the embankment material should be modeled using the simplest representation possible that is appropriate for the problem analyzed (Duncan, 1996). However, while simple linear elastic, multi-linear elastic or hyperbolic models may be appropriate for analyzing stress states well prior to failure, more complex stress-strain models (e.g., elasto-plastic and elasto-viscoplastic) are required to analyze slope behavior near failure.

The elasto-plastic and elasto-viscoplastic FE approach to slope stability analysis offers the following advantages over traditional methods (Griffiths and Lane, 1999):

- No a priori assumptions are needed relative to the shape or location of the failure surface. Failure occurs “naturally” through zones in the soil mass where the shear strength is unable to support the gravity-induced shear stresses.
- Because there is no concept of slices in the finite element approach, there is no need for assumptions about slice side forces, and the finite element method preserves global and local equilibrium until failure is reached.
- The finite element method can indicate progressive failure up to and including overall shear failure.

Slope stability analysis using the finite element method requires the following steps:

- Gravity loads are applied to the slope.
- An elastic analysis is performed to compute stresses.
- Stresses in each element are compared with the Mohr-Coulomb failure criterion.
- If stresses exceed the Mohr-Coulomb criterion, they are redistributed to neighboring elements that still have reserve strength.
- Slope failure occurs if stress redistribution cannot be accomplished to satisfy the Mohr-Coulomb criterion and global equilibrium. Failure is indicated by significantly increased nodal displacements.

Finite element analyses are not commonly used for the design of refuse embankments, but have application for the analysis of embankments where unexpectedly large deformations are observed or where unusually soft foundations may lead to unacceptable plastic deformations or differential settlements. Additionally, finite element analyses may prove to be a useful tool for evaluation of the effects of deformation on embankment stress and for the evaluation of mine subsidence effects.

6.6.4.3 Acceptable Factors of Safety

Selection of an acceptable factor of safety for the analysis or design of an embankment slope depends on the degree of uncertainty in calculating FS and the hazards or consequences should a slope fail. The calculation of the factor of safety for a coal refuse disposal facility embankment involves evaluation of many factors, including:

- Uncertainties about the type and extent of sampling and testing to determine material strengths
- The variation of materials in the embankment and impoundment
- Uncertainties of embankment geometry
- The type of embankment (e.g., new or existing, impounding or non-impounding, constructed by upstream method or downstream method)
- The level of uncertainty concerning the location of the phreatic level and related excess pore-water pressures
- Embankment location (e.g., in a V-shaped valley, high seismic region)
- The accuracy of the stability analysis method(s) used
- Potential for future loads
- Potential for future changes in disposal operations and practices

The hazards or consequences associated with refuse embankment failure include:

- Potential for loss of life and/or property damage on site
- Potential for loss of life and/or property damage off site
- Economic cost to mining operations if disposal operations are lost
- Economic cost associated with restoring or safely abandoning disposal operations
- Economic cost of restoring environmental damage

The magnitude of the factor of safety to be used for coal refuse disposal facility design should be determined by the designer considering state and federal regulatory requirements and the completeness and accuracy of designer's knowledge of the uncertainties and conditions identified previously. If these uncertainties and conditions are well defined, or if conservative assumptions have been made, a lower *FS* may be acceptable. Conversely, when many assumptions are made relative to forces and material strengths, a higher *FS* is appropriate.

In selecting an acceptable *FS* for the stability of embankment slopes for coal refuse disposal facility design, the practices of major engineering organizations, both governmental and private, should be considered. Most earth dams in the U.S. are designed based upon extensive laboratory test information and clearly identified loads and geometry. For these structures, a $FS \geq 1.5$ is generally considered to be acceptable for permanent or sustained loading conditions. For special circumstances, such as soft embankment foundations, a higher *FS* is sometimes adopted to limit foundation or embankment deformations. For temporary loading conditions during construction, a lower *FS* is often acceptable. For transient loads, such as earthquakes, a *FS* of 1.2 is generally acceptable depending on the design earthquake magnitude, as discussed in Chapter 7. Minimizing the volume of material used for construction is not usually a design goal for refuse embankments as it is for earthen dams; thus, it may be possible to achieve somewhat higher factors of safety for refuse embankments without introducing special materials or operations, and the designer may be able to accommodate concerns about uncertainty of engineering properties or loads.

Table 6.56 presents recommended minimum factors of safety for the design of coal refuse embankments based on values adopted by the cited federal agencies (USSD, 2007). These values are generally consistent with factors of safety cited in the MSHA Impoundment Inspection and Plan Review Handbook (MSHA, 2007) and have been adopted by many state regulatory agencies.

The values of *FS* provided in Table 6.56 apply if the following conditions are met:

TABLE 6.56 RECOMMENDED MINIMUM FACTORS OF SAFETY FOR DESIGN OF COAL REFUSE EMBANKMENTS

Condition	Design Basis	Factor of Safety	Source ⁽¹⁾
Long-term stability analysis with maximum storage pool	Design based on shear strength measured in laboratory and/or field testing program reflecting long-term site development with steady-state seepage and maximum storage (operational) pool.	1.5	USACE, USBR, NRCS, FERC
Long-term stability analysis with maximum surcharge pool	Design based on shear strength measured in laboratory and/or field testing program reflecting long-term site development with steady-state seepage and maximum surcharge (design storm) pool.	1.4	USACE, FERC
Intermediate-stage static analysis with maximum storage pool	Design based on shear strength measured in laboratory and/or field testing program reflecting intermediate-stage critical configurations using long-term analysis with steady-state seepage and maximum storage (operational) pool.	1.5	
Intermediate-stage static analysis with maximum surcharge pool	Design based on shear strength measured in laboratory and/or field testing program reflecting intermediate-stage critical configurations using long-term analysis with steady-state seepage and maximum surcharge (design storm) pool.	1.4	
Short-term, end-of-construction, undrained static analysis	Design based on intermediate- or long-term configurations and supported by shear strength measured in laboratory and/or field testing program using undrained strength parameters, as appropriate.	1.3	USACE, USBR, FERC, TVA
Rapid-drawdown analysis with maximum storage pool	Design based on intermediate or long-term configurations and supported by shear strength measured in laboratory and/or field testing program using drained or undrained analysis.	1.3	USACE, USBR
Seismic analysis	Discussed in Chapter 7.	–	

Note: 1. From USSD (2007).

- The critical failure surface has been determined from stability analyses based on systematic searches and evaluation of defined planes of weakness.
- Stability analysis parameters are, with reasonable certainty, known to be representative of the actual conditions that will exist in the embankment.
- Sufficient control will be provided during construction to verify that materials placed within the embankment conform to the standards assumed or required by the disposal facility design.
- When pore-water pressure in an embankment and its foundation is a significant factor in the stability of the embankment, piezometers are installed and monitored, and the observed data are compared to design assumptions.

If an existing coal refuse disposal embankment is found to have a low FS , it may not be possible to modify the site sufficiently within a short time period to satisfy minimum FS criteria. In such cases, a slight, temporary reduction in the FS may be acceptable provided that:

- Monitoring of pore pressures in the embankment and movements of the embankment surface is performed on a scheduled basis.

- A plan to improve the *FS* is developed and implemented (e.g., the impoundment level is lowered, the embankment upstream face is sealed to reduce seepage, pore pressures are measured, or other steps to reduce the impounding capacity or to implement abandonment are initiated).

When test data for embankment and foundation materials are limited or available test data are inconsistent, either conservative values of shear strength and pore-water pressure should be used in the stability analysis or an increased *FS* should be used in the embankment design.

6.6.4.4 Stability Control Measures

The most effective measures for stabilizing coal refuse embankments and other slopes are: (1) drainage control and (2) buttress fills. Drainage control is probably the most frequently used and often the most effective measure because slope failures are very often the result of increases in groundwater level, phreatic surface level or pore pressures. Also, drainage control is often the least expensive and most easily implemented of the options that are typically available. The types of drainage control measures (Section 6.6.2.3) that can be employed include:

- Surface control using ditches designed with a gradient and lining that limits infiltration into the slope and conveys surface flows to a drainage outlet.
- Lowering of the impoundment pool level, if feasible, and consideration of partial liner systems placed on the upstream slope to limit seepage.
- Occasional movement of the slurry discharge point so that fines are distributed along the upstream embankment slope, limiting seepage and pushing the free water further away from the embankment.
- Horizontal drains drilled at an upslope gradient into the downstream face of the embankment to intercept water up to 400 feet from the face. As discussed in Section 6.6.3.3, prefabricated drains have been used to control pore pressures and improve consolidation of impoundment fines.
- Relief wells to intercept artesian water pressure at the downstream toe of the embankment. The wells may be furnished with pumps to convey flow to a drainage outlet.
- Trench drains extending below the toe of the downstream embankment slope or into a bench on the slope. Flow is conveyed by gravity and typically in pipes to a drainage outlet.
- Finger drains excavated perpendicular to and typically at a shallow depth into the downstream face of the embankment to intercept water flow at a shallow depth.
- Blanket drains placed at the surface of downstream embankment slopes where seepage or piping is occurring. Blanket drains, especially when incorporated into a buttress, also add weight to help increase the effective stress.

Structural buttress and gravity berm fills constructed at the toe of an embankment also serve to increase stability. A structural buttress fill constructed with well-compacted, high-strength material improves stability by providing both strength and weight. A gravity berm fill using uncompacted material improves stability by providing weight to reduce shear stresses at the toe of the embankment slope. The effectiveness of either type fill can be improved by placing a layer of free-draining material between the embankment face and the fill to convey water draining from the face of the embankment slope to a drainage outlet.

Other types of stabilization measures such as structural and ground improvement options may be considered, but these choices typically require greater time to implement and are more expensive and less effective than drainage or toe buttress stabilization measures.

6.6.4.5 Stability Measurements

Parameters that influence the slope stability factors of safety should be monitored during and after each stage of construction by instrumentation to provide a basis for checking the design factor of safety so that modifications to the design or to construction procedures can be made, if needed. Depending on site conditions and project requirements, embankment performance monitoring instrumentation may include:

- Surface monuments for monitoring vertical and horizontal displacements
- Inclinometers for monitoring lateral displacements at depth
- Piezometers for monitoring piezometric head

In addition, monitoring of density test results is important to stability because it provides an indirect method to monitor the strength of the compacted fill. Thus, the minimum compaction requirement serves to ensure that the shear strength of the compacted fill is consistent with the strengths obtained from laboratory testing and used in the stability analysis.

An extensive discussion of instrumentation for coal refuse disposal facilities is provided in Chapter 13.

6.6.5 Rock Excavations

Excavations into rock at coal refuse disposal facilities are usually associated with: (1) spillway channels, (2) diversion ditches, and (3) haul roads. Less frequently, rock excavations are associated with decant structure installation and obtaining borrow material.

The degree of assurance that an excavated rock slope will remain stable and has a sufficient factor of safety for each of these purposes will depend on facility design requirements. This section provides a discussion of the stability of rock excavations, methods for minimizing the potential for a failure, and procedures for improving stability.

6.6.5.1 Conditions Requiring Stability Analysis

Major factors that must be considered when evaluating the stability of rock excavations include:

- Existing ground surface slope
- Overburden soil thickness, type and quality
- Bedrock surface conditions
- Rock type, quality and configuration (particularly the orientation of discontinuities)
- Groundwater conditions

6.6.5.1.1 Existing Ground Surface Slope

The steepness of the existing ground surface is an important factor in both the cost of excavation and the resulting stability. [Figure 6.56](#) provides a guide for estimating both the vertical and horizontal extent of rock excavations as a function of existing slope, cut width, and cut slope. In steep areas where existing slopes are only marginally stable, deep excavations are very expensive because of the volume of material to be excavated and protection requirements.

6.6.5.1.2 Overburden Soil Thickness, Type and Quality

Usually the top portion of an excavation into rock extends through overlying soils. The need for a shallower slope and erosion protection in the overburden soil portion of the excavation must be considered in evaluating the limits of excavation and related costs.

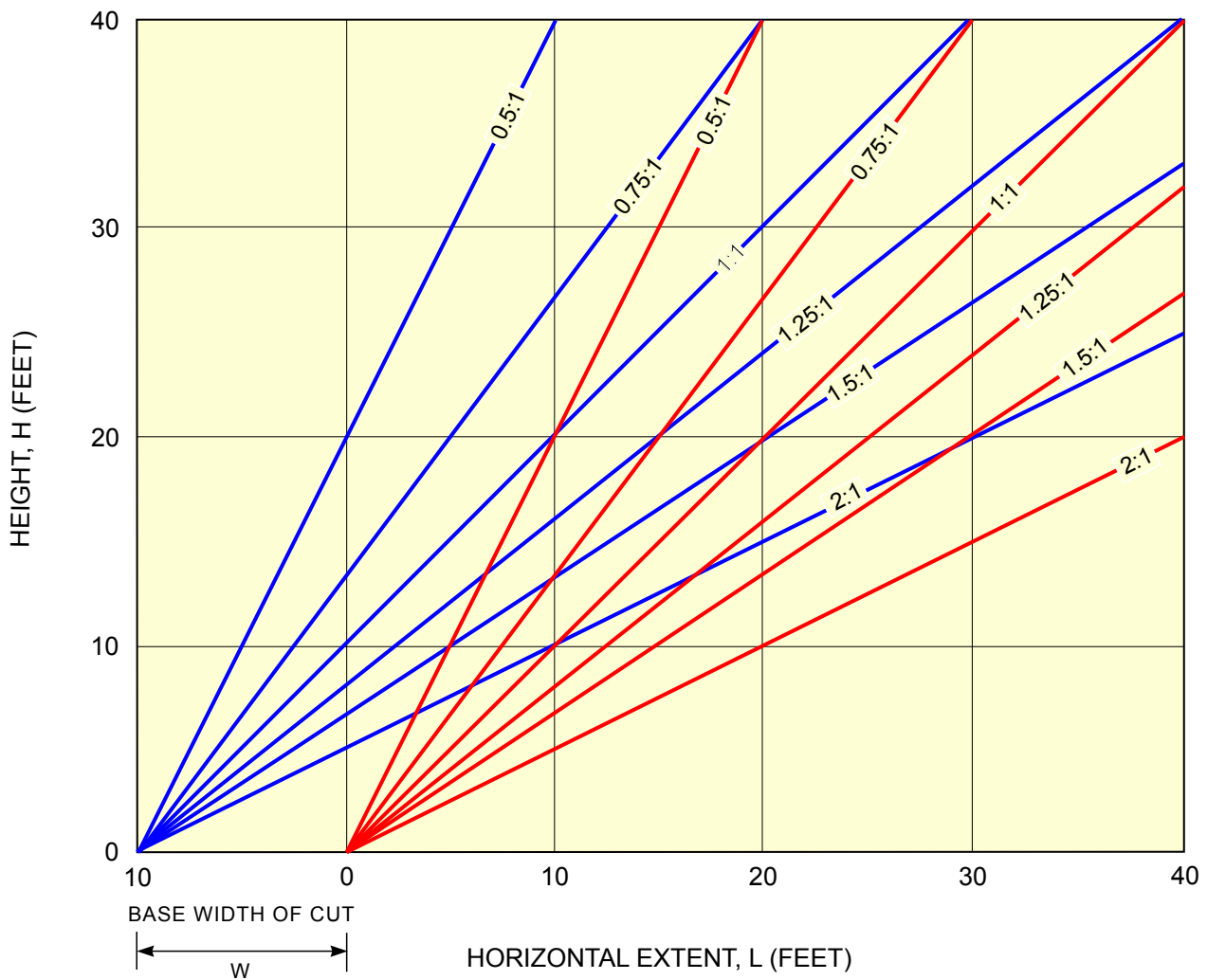

LEGEND

- EXISTING SLOPE (S_E)
- SLOPE OF CUT (S_C)

(1) $S_E > S_C$

(2) $L = W \frac{S_C}{S_E - S_C}$

(3) $H = \frac{L}{S_C}$

FOR $W \neq 10$ FEET, MULTIPLY THE VALUES OF L AND H OBTAINED FROM THE GRAPH BY COEFFICIENT $C = W/10$.

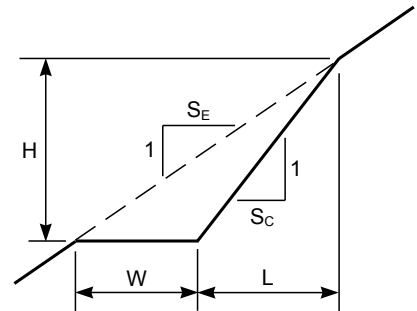

FIGURE 6.56 HORIZONTAL AND VERTICAL EXTENT OF CUTS FOR BASE WIDTH OF 10 FEET

6.6.5.1.3 Bedrock Surface Conditions

As shown in Figure 6.57, the bedrock surface can be difficult to define because of weathering, downhill slope creep and loosening from stress relief. Except where rock is very massive, conditions normally change with depth from: (1) overburden soil consisting of colluvial and residual material to (2) soft, heavily weathered rock and then to (3) sound and competent rock. Heavily weathered, decomposed rock should be treated as soil to a depth determined by an experienced geologist or engineer. Particular caution is required for soft rocks (e.g., shale, siltstone, claystone and mudstone) that weather very rapidly when exposed to air, rainfall and freezing conditions.

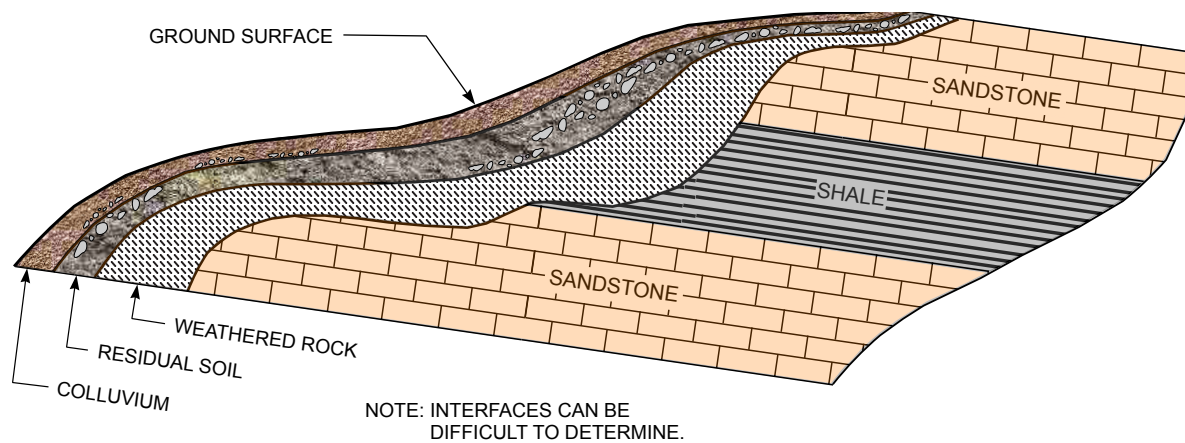

FIGURE 6.57 SCHEMATIC GEOLOGICAL PROFILE OF A BEDROCK SLOPE

6.6.5.1.4 Rock Type, Quality and Configuration

Generally the design of a cut into competent rock is technically simple and requires only application of the designer's judgment or general experience. However, when rock conditions are such that analyses are required for demonstrating adequate stability, detailed evaluation is frequently more complex than the evaluation of the stability of a soil slope. A rock mass may consist of: (1) a layered system of individual beds of different type rocks with variable bed thickness and strength and (2) discontinuities such as bedding planes, joints, fractures and faults that have much lower strengths than the intact rock. These discontinuities control rock slope stability, but can be difficult to define for purposes of analysis. The types and characteristics of rock most often found in coal mining areas are:

- **Soft Rocks – Shale, Siltstone, Claystone and Mudstone** – Rapid weathering of these types of rocks affects their strength, which eventually decreases to that of soil. Where these rocks are exposed, it must be expected that weathering will occur during the useful life of the facility. When exposed soft rock underlies massive, more competent rock, particular care must be taken to avoid instability as the soft rock weathers and provides less support. Also, erosion of soft rocks can be a problem, particularly when they are thinly-bedded and exposed to surface water flows for long periods.

Excavation of soft rocks can usually be accomplished with dozers, shovels, scrapers or backhoes. Even when competent, these rocks can be ripped without blasting using a bulldozer.

- **Harder Rocks – Limestone and Sandstone** – These types of rocks are more resistant to weathering. Strength is usually high if defects such as fractures or interbedded units of softer rocks do not occur at critical locations. Defects and weak cementation can also adversely affect the erosion resistance of these rocks, which is otherwise good to excellent.

The exploration and evaluation of rock defects is very important. The characteristics of rock defects reported as part of an exploration program generally include type, quality, thickness, strike and dip, continuity, extent, frequency, and relative strength. The orientation of rock defects relative to the excavation is critical. For example, Figure 6.58 illustrates two conditions where orientation of bedding planes dipping into a cut and "daylighted" by the excavation could cause bedrock sliding along these planes. The extent of a potential slide could be small (Figure 6.58a) or large (Figure 6.58b) depend-

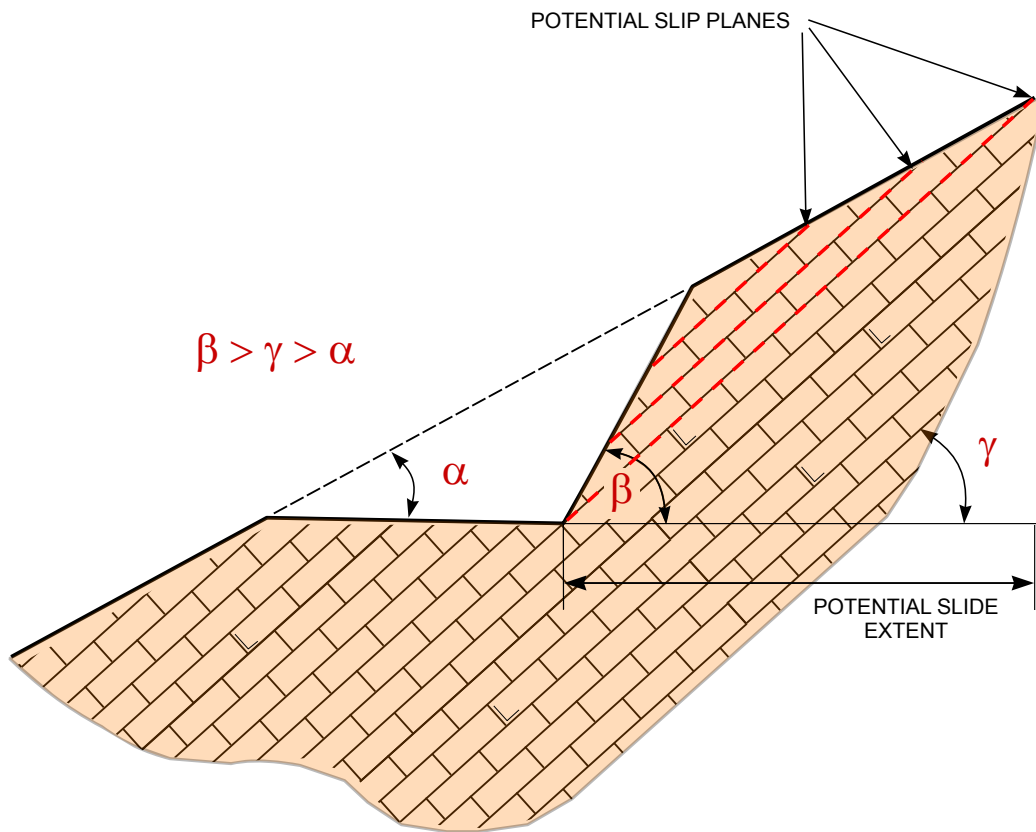

6.58a EXTENT OF POTENTIAL SLIDE (SMALL)

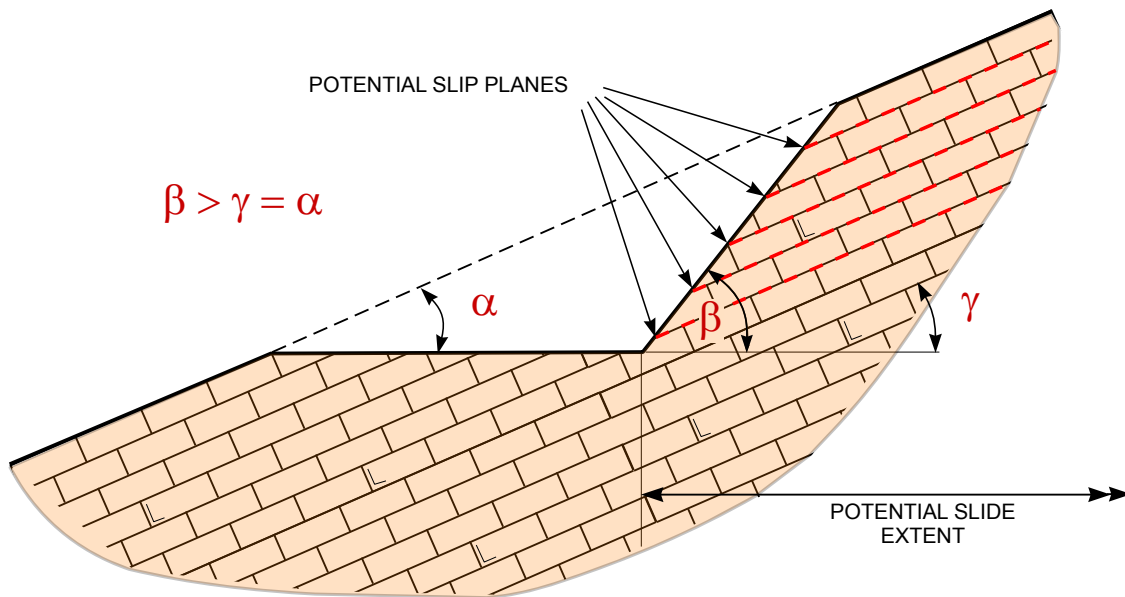

6.58b EXTENT OF POTENTIAL SLIDE (SEVERE)

FIGURE 6.58 UNFAVORABLE ORIENTATION OF BEDDING PLANES

ing on the interrelationship of the dip angles of the existing slope, cut and bedding planes. [Figure 6.59](#) shows three cases of favorable bedding plane orientation. Even with a favorable bedding plane orientation there may be potential for failure if the rock is highly fractured ([Figure 6.59b](#)) or if a capable fault is present ([Figure 6.59c](#)).

Thinly layered strata of limestone and sandstone are usually rippable and are not extremely difficult to excavate. However, thick layers of competent rock will require blasting.

Because sedimentary strata are layered, harder more competent rock may overlies softer, less competent rock. Weathering of the softer rock will occur faster than weathering of the harder rock and can lead to overhangs of the more competent and more massive harder strata. For permanent excavations, slope conditions should be observed over time, and large and potentially dangerous overhangs should be eliminated by occasionally scaling the slope to make it more uniform in geometry. If loose rock should develop, it should be removed or the potential rockfall zone should be barricaded.

6.6.5.1.5 Groundwater Conditions

It is important to recognize that the flow of groundwater through a rock formation can cause distress. Excessive pressure along bedding planes or in fractures, can contribute to rock movements. Also, flowing water can cause erosion of defects either chemically from solutioning or mechanically from fines washing from joints and fractures. Both types of erosion can weaken the strength of a rock mass. Finally, freezing water in fissures and cracks can widen existing fractures and accelerate the weathering process or can act as a dam to create higher water pressures behind the face of the slope.

6.6.5.1.6 Other Factors

Other factors that can affect the stability of rock cuts include:

- Erosion from precipitation associated with large storms or long wet periods
- Infiltration associated with precipitation
- Vegetation growth
- Shocks and vibrations from blasting or earthquakes
- Changes in loading conditions

6.6.5.2 Slope Stability Analysis

The stability of cuts in rock can be analyzed using two basic approaches. Analyses similar to those used for soil slopes ([Section 6.6.4](#)) can be used if the rock mass can be assumed to act as a homogeneous medium. This condition could apply when the rock strength is not governed by particular planes of weakness. In most cases, however, discontinuities govern rock behavior, and principles of rock mechanics can be used for stability analyses, as discussed by [Wyllie and Mah \(2004\)](#), [Hoek \(2000\)](#), and [Coates and Yu \(1977\)](#).

Most small rock excavations, where failure would not represent a severe hazard, can be designed based on experience with similar geological conditions. The slopes for these conditions usually range from 2 horizontal to 1 vertical (2H:1V) to 0.5H:1V for soft rocks and from 1H:1V to nearly vertical for hard rocks unless the orientation of weakness planes require flatter slopes. The uniformity of a rock slope is often broken by benches or berms for controlling runoff and catching loose rock fragments and debris.

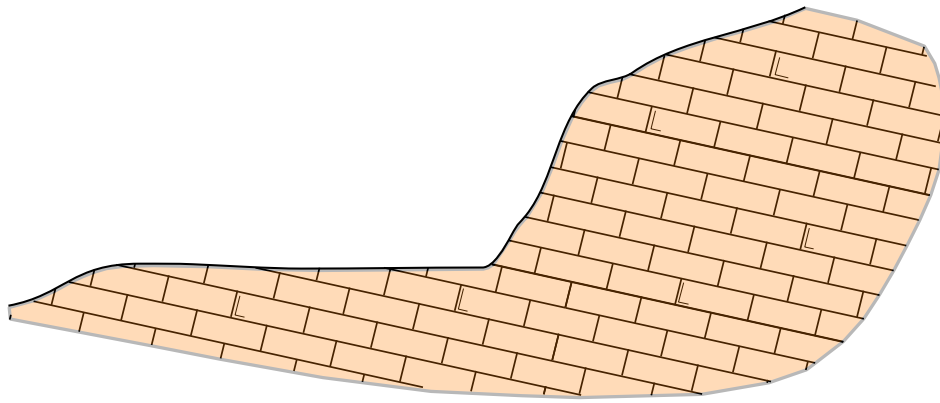

6.59a ROCK IS COMPETENT

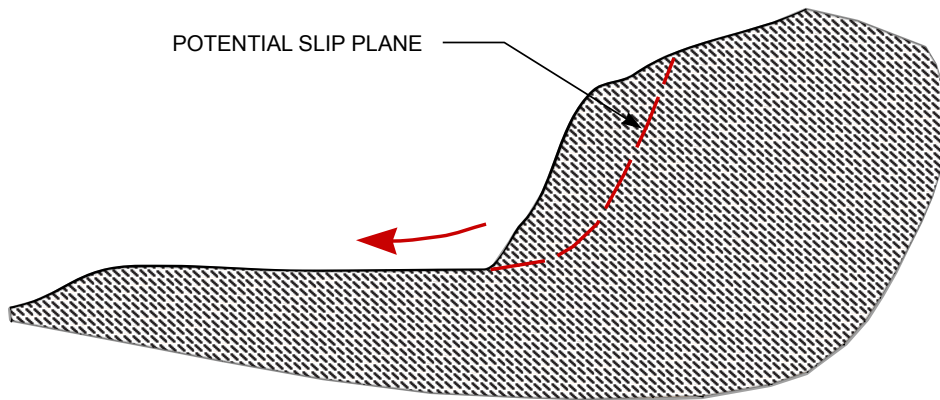

6.59b ROCK IS HIGHLY FRACTURED

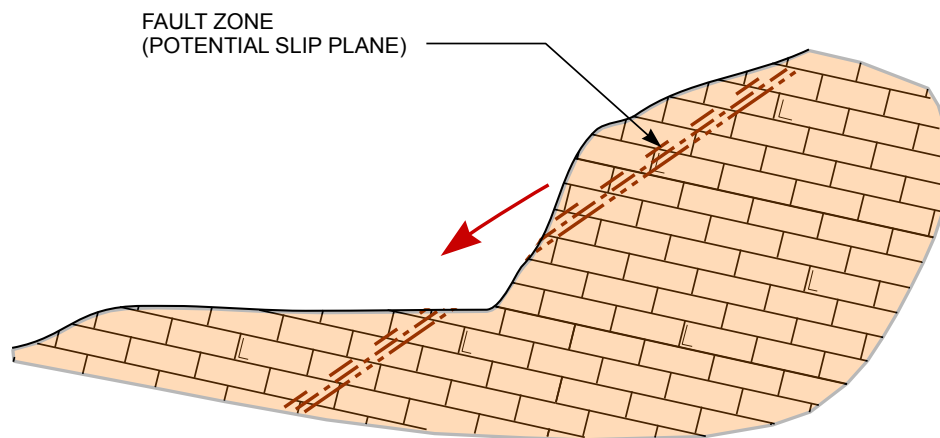

6.59c FAULT ZONE IS GOVERNING FEATURE

FIGURE 6.59 FAVORABLE ORIENTATION OF BEDDING PLANES

Guidance for rock cut slopes above roadways is presented by ODOT (2006), based on the slake durability index (SDI), rock quality designation (RQD) values, and unconfined compressive strength. Construction bench and debris width guidance is also provided.

6.6.5.3 Stability Control Measures

An approach to stability control developed by ODOT (2006) is illustrated in Figure 6.60. The advantage of this technique is that ample horizontal area is provided for debris collection and vegetation growth after construction. The edges of individual steps gradually break down and debris is collected at the benches so that vegetation growth helps to protect against sloughing and erosion. The individual benches and steps do not have to be spaced equally or be level. To minimize the cost, the steps should be cut during initial excavation.

Several remedial alternatives are available when difficulties with the stability of rock excavations are anticipated or encountered. Benching of the rock slope can be a simple means of improving stability. Other methods, as shown in Figure 6.61, include:

- Construction of a bench with optional retaining berm or wall at the toe of slope to catch falling rock debris.
- Construction of a retaining wall against all or a portion of the slope.
- Prevention of rock weathering and sloughing by anchoring a wire mesh (with optional shotcrete overlay to protect against weathering) to the rock slope.
- Containing loose rock on the cut face with rock bolts, possibly combined with mesh.
- Supporting the rock face with tiebacks anchored below potential slide planes.
- Placing concrete or masonry support to replace weathered soft rock supporting overlying layers of harder rock.

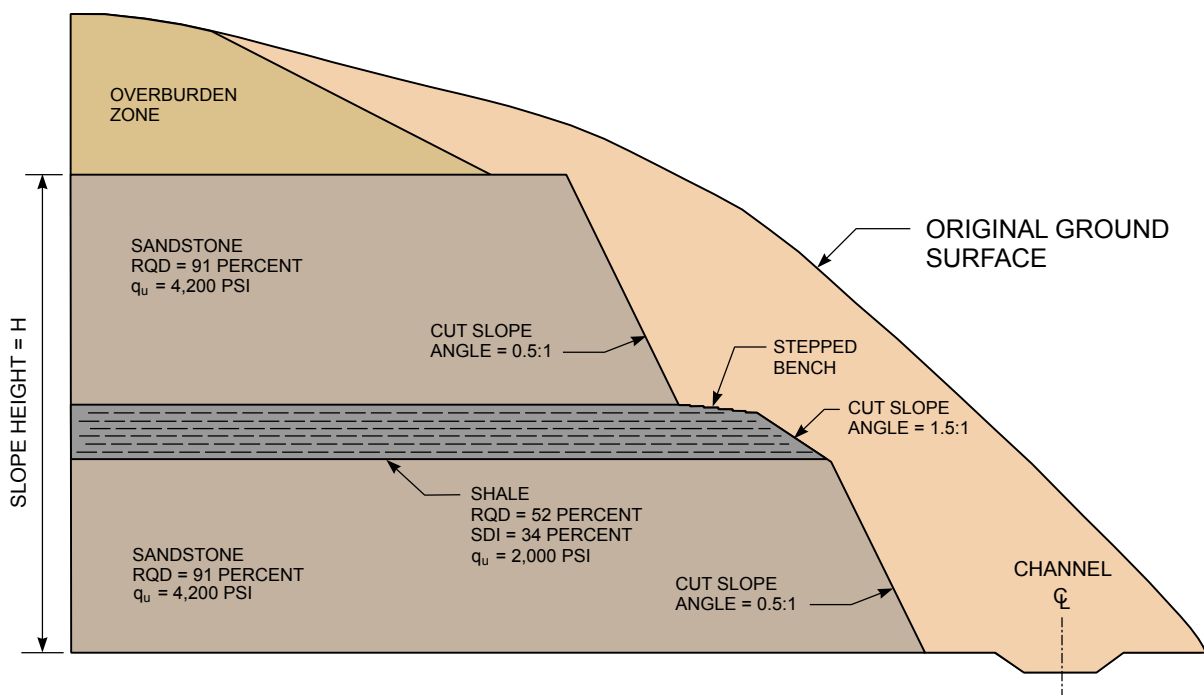

(ADAPTED FROM ODOT, 2006)

FIGURE 6.60 STEPPED SLOPE EXAMPLE FOR CUTS IN WEATHERED ROCK

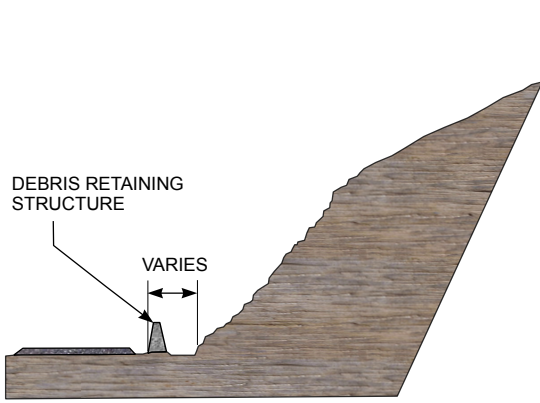

ROCK-FALL CATCHMENT

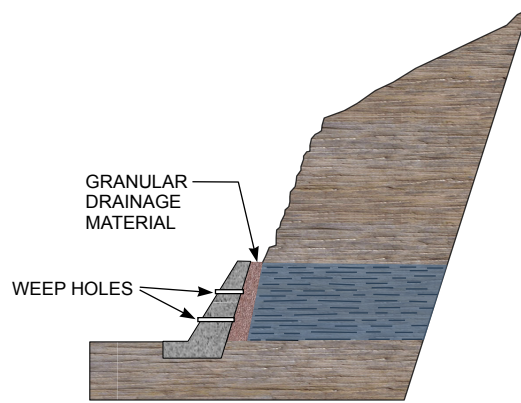

RETAINING WALL

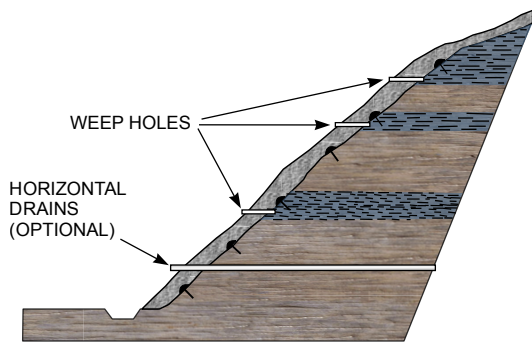

WIRE MESH WITH OR WITHOUT GUNITE

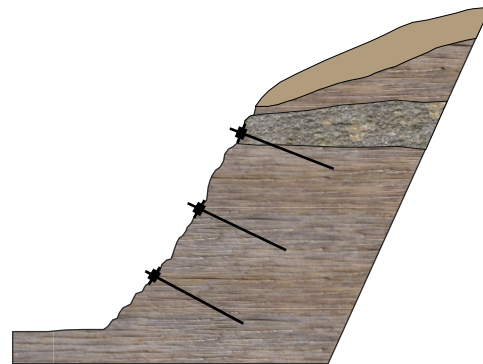

ROCK BOLTS

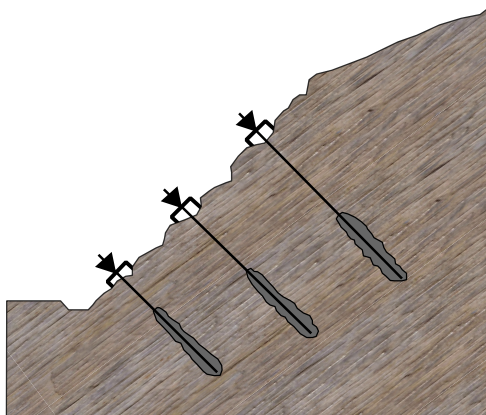

TIE-BACK ANCHORS

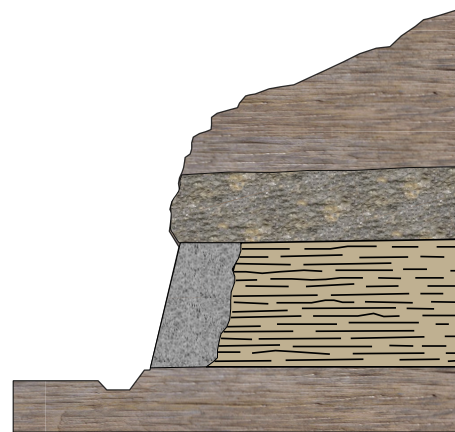

CONCRETE OR MASONRY SUPPORT

FIGURE 6.61 EXAMPLES OF ROCK-CUT CONTROL

All of these support techniques are costly and require contractor expertise and monitoring by experienced engineering personnel for successful implementation.

Where stabilization of highwalls is not practical, safety zones where access is restricted should be considered. The extent of safety zones can be established using computer programs such as the Colorado Rockfall Simulation Model (Jones et al., 2000) to delineate the area that could be affected by rockfalls and to estimate the size of the berm that should be constructed to retain materials that fall from the rock face.

6.6.5.4 Stability Measurements

When the stability of a rock slope is important to the design of a coal refuse disposal facility, estimates of deformations should be made for comparison to field observations. Depending on site conditions and project requirements, rock slope performance can be monitored by:

- Surface monuments for monitoring vertical and horizontal displacements
- inclinometers for monitoring subsurface lateral displacements within slopes

Instrumentation for mine refuse disposal sites is presented in Chapter 13.

6.6.6 Conduit Structural Design for Earthen Fill Loads

At coal refuse disposal facilities, conduits are used to convey water from an impoundment through, under, or around a refuse embankment dam in a controlled manner. They are also used to convey surface water under haul roads and to control surface flows at the periphery of impoundments and refuse embankments. Conduits through refuse embankments serve the following purposes:

- Convey stored waters to the coal preparation plant
- Provide emergency reservoir evacuation capability
- Provide a primary or secondary outlet for passing storm water flow

A conduit through a refuse- or water-impounding embankment creates a discontinuity in the embankment cross section. Therefore, the structural design and construction of conduits for these situations must address potential problem conditions that have led to the distress and/or failure of impounding embankments. Some of these potential problem conditions include:

- Differential settlement between the conduit and the surrounding embankment due to difference in stiffness between the conduit and surrounding material.
- Differences in compaction between the backfill around the conduit and the remainder of the embankment.
- Structural defects in the conduit resulting from deterioration, overstressing due to lack of proper backfilling under conduit haunches or excessive fill heights, cracking due to foundation compression or lateral extension, or joint separation due to poor design and construction.
- Water leaking from the conduit that can lead to increased seepage, especially under pressurized flow conditions, in the embankment.
- Seepage flowing into an open conduit joint or crack in a conduit leading to internal erosion in the embankment.

There are special design considerations for conduits through impounding embankments that are unlike those for conduit applications that do not involve dams or impoundments. These include:

- Limiting the number of joints to maintain water tightness and to minimize the potential for internal erosion, backward erosion piping, and structural deterioration.
- Limiting flow velocity to minimize the potential for cavitation and erosion.
- The need for seepage control structures along the outside of the conduit.
- Accommodating fluctuating flows due to seasonal conditions and operating requirements.
- Accommodating flow interruptions to meet inspection and maintenance requirements.
- Maintaining operating tolerances for gate and valve functionality.

The following sections describe the types of conduits typically used at coal refuse embankments, including their structural characteristics and methods used for structural design and conduit installation (FEMA; 2005a, 2007). Hydraulic design issues for coal refuse embankment conduits are presented in Chapter 9.

6.6.6.1 Conduit Types

The materials used for conduits at coal refuse disposal facilities include reinforced precast concrete, thermoplastics, and welded steel pipe. High-density polyethylene (HDPE) is currently popular due to its light weight, durability, corrosion resistance, lower cost and the use of fuse-weld pipe joints to make the constructed pipe virtually jointless except at upstream extensions of decant pipes. Precast, prestressed concrete cylinder pipe also has a long history of satisfactory performance and resistance to structural deterioration. However, product cost, heavy weight and the frequency of joints are limitations that must be considered. Coated steel pipe is also used at refuse disposal facilities. A general discussion of the characteristics of concrete, thermoplastic and metal conduits including advantages and disadvantages is presented in the following sections.

6.6.6.1.1 Concrete

Types of precast concrete pipe typically used for conveying water through dams and impounding refuse embankments include reinforced concrete pipe (RCP), reinforced concrete cylinder pipe (RCCP), and prestressed concrete cylinder pipe (PCCP). RCP is used to convey flows under gravity head. RCCP and PCCP have seals at the pipe joints and thus are able to convey flow under pressure head. Precast concrete pipes are typically circular in cross section. Rectangular (or box) precast conduits are seldom used in dams and impounding refuse embankments because watertight joints cannot be reliably constructed.

The advantages of using precast concrete pipe for conduits include:

- The pipe is manufactured in a controlled environment to tight tolerances.
- Installation is relatively quick.
- Varying settlement along the pipe length can be accommodated by articulated joints between sections.

The disadvantages of using precast concrete for conduits include:

- There is a potential for opening of joints due to embankment settlement or elongation because longitudinal reinforcement does not extend across joints.
- Shipping and handling limitations result in short pipe section lengths and numerous joints over the length of the pipe, leading to an increase in the number of potential leakage locations.

- Gasketed joints are the only defense against leakage.
- Compaction of backfill is difficult under the pipe haunches.

While reinforced cast-in-place concrete pipe has a long history of successful performance for water-impounding dams, it is seldom used at coal refuse disposal facilities due to the extended timeframes over which the lengthy decant conduits are constructed, the difficulty of delivering adequate volumes of fresh concrete (to what are often remote locations) during pipe construction, the complexity of formwork and related construction, and the susceptibility to cracking and other distress associated with settlement.

6.6.6.1.2 Thermoplastic

Thermoplastics are solid materials that change shape when heated, and they commonly include polyethylene (PE) and polyvinyl chloride (PVC). Thermoplastic pipe is produced by an extrusion process, in which molten polymer material is continuously forced through an angular die by a turning screw. The die shapes the molten material into a cylindrical shape. After a number of additional processes, the final product is cut into pipe lengths that are suitable for delivery and handling.

The thermoplastic material most commonly used in refuse facilities is solid-wall HDPE. HDPE pipe is relatively inert chemically and thus is not particularly prone to corrosion or deterioration, has a long service life, and requires little maintenance. This is especially important for small-diameter pipes that are not easily renovated and cannot be easily inspected. HDPE is typically available in sizes up to 63 inches in diameter. Manufacturers can fabricate HDPE custom pipe fittings in addition to common fittings such as bends, flanges, reducers, and transitions.

The advantages of using thermoplastic pipe include:

- Its light weight facilitates relatively quick and simple installations.
- It resists corrosion and is not affected by most naturally occurring soil and water conditions.
- Its smooth interior surface limits friction loss and is resistant to the adherence/buildup of minerals such as calcium carbonate.
- The pipe is relatively watertight pipe if pipe joints are properly heat fused.
- It is resistant to biological attack.

The disadvantages of using thermoplastic pipe include:

- Its susceptibility to damage or displacement by construction and compaction equipment.
- Proper compaction of backfill at pipe haunches is difficult.
- Heat fusion of pipe joints requires special equipment and an experienced operator.

6.6.6.1.3 Metal

Metal conduits used at coal refuse disposal facilities are typically limited to welded, coated steel pipe. Steel pipe with diameters of 24 inches and smaller (36 inches and smaller at some shops) is manufactured in standard wall thicknesses and diameters. Pipe that is greater than 24 inches in diameter can be custom manufactured to any desired diameter. Standard diameters for steel pipe with diameters greater than 24 inches are listed in Manual M11 published by the American Water Works Association (AWWA, 2004). Minimum plate (wall) thickness for larger-diameter pipe is one-quarter inch. Available plate thicknesses increase by multiples of one-sixteenth inch.

Steel pipe can be protected with a variety of linings and coatings. Frequently, the interior lining is not the same as the exterior coating because of the difference in exposure conditions between the interior

and exterior surfaces. Typically, the interior surface is lined with the same coating regardless of location. The exterior surface coating will depend on location, encasement, and whether or not the pipe is submerged. The exterior surface is usually uncoated if it will be encased in concrete. Interior coatings and linings for mitigation of corrosion should be selected consistent with the anticipated fluid velocities within the pipe. Cement mortar should only be used on the interior surfaces of steel pipe where flow velocities will be low.

The advantages of using steel for conduits include:

- It is manufactured to tight tolerances in a controlled environment.
- It has a long service life, if proper linings and coatings are used.
- Welded joints provide watertightness.
- It can be constructed on compressible foundations.
- It has high compressive and tensile strength.
- It is flexible and deformable under stress.
- Its high modulus of elasticity provides resistance to buckling loads caused by external water pressures.
- A wide variety of special sections can be fabricated.
- It is easy to connect additional steel pipe in the future by tapping and welding.
- Flanges provide a rigid connection to gates and valves.

The disadvantages of using steel for conduits include:

- The material cost is high.
- Proper selection of linings and coatings and associated protection and maintenance measure is necessary in order to prevent corrosion.
- Proper compaction of backfill at pipe haunches is difficult.
- Special linings are required at impoundments where aggressive/corrosive water may be present (e.g., acidic mine drainage).

Corrugated Metal Pipe (CMP) applications are generally limited to surface drainage culverts and other near-surface installations where maintenance or replacement can readily be accomplished.

6.6.6.2 Soil-Structure Design

Conduits should be designed to withstand a variety of loads and pressures including:

- Internal fluid and vacuum pressures
- External hydrostatic loadings and buckling pressures
- Embankment loads
- Surface surcharge loads
- Construction loads from handling or equipment trafficking
- Operational and maintenance loadings
- Load combinations

Designers should also consider the effects of vertical and horizontal displacements that might occur due to settlement and spreading of the embankment and foundation during construction. These dis-

placements could result in loads on the conduit that exceed the design loads listed previously. Excessive displacements, both vertical and lateral, can occur when conduits have foundations that are either weak, compressible, or both. Poorly compacted embankments or embankments supported on compressible foundations can deform due to shear forces, and this deformation can lead to lateral spreading of conduits (Rutledge and Gould, 1973).

FEMA (2005a) recommends that conduits be analyzed for the following loading conditions:

- Usual – Includes: (1) normal operating conditions with the reservoir at or near normal pool, involving combinations of vertical soil load (due to the weight of the fill above the pipe), (2) horizontal soil load, (3) external and internal hydrostatic pressure loads, and (4) the vertical foundation reaction (typically assumed to be equal to the vertical soil load plus the weight of the conduit).
- Unusual – Includes loads resulting from high reservoir levels and elevated discharges associated with flood conditions. Because floods typically have a short duration, conduits may not be significantly affected by increased external hydrostatic pressure. The difference between usual and unusual loading conditions could be limited to increased internal hydrostatic pressure.
- Extreme – Usual loading conditions plus earthquake loading. Depending on the consequences of failure of (or severe damage to) a conduit and vertical concrete riser intake (particularly, if of appreciable height) under seismic loading, a range of earthquake loadings may need to be considered, including the seismic loading associated with the maximum credible earthquake, if conduit operation is required for preventing overtopping during the design storm. Conduits are “low-profile” structures and tend to have a relatively high natural frequency. Unless a conduit is founded on deep layers of soil where peak ground accelerations could be magnified, unamplified peak ground accelerations are typically assumed to act on the conduit. If the natural frequency of the conduit is greater than 33 Hz, a pseudostatic analysis generally provides acceptable results. Other factors that may affect loading conditions are the type of foundation, method of bedding, flexibility of the pipe, and soil properties. Generally, conduits designed with an adequate static factor of safety are unlikely to buckle without a substantial stiffness reduction of the embedding soil under earthquake loading. Davis and Bardet (1998) describe a pseudostatic analysis and estimate backfill stiffness reduction, demonstrating that critical conditions would be associated with high pore-pressure buildup under low vertical effective stress (e.g., low depth of cover).
- Construction – Pertains to loads resulting from construction activities such as construction vehicles or equipment moving or working near or over the conduit.

The Marston theory (Moser, 2001) is typically used to calculate loads on a conduit that is partially or fully projecting above the original ground surface. The vertical load on the conduit is considered to be a combination of the weight of the fill directly above the conduit (i.e., prism load) and the frictional forces from adjacent fill acting upward or downward at the boundaries of the prism of earth above the conduit. This combined loading is also known as the “projection” condition. As illustrated in Figure 6.62, there are two projection loading conditions. The embankment condition shown in Figure 6.62a occurs when fill adjacent to a conduit settles more than the fill directly above the conduit. As a result, downward frictional forces act on the prism of earth above the conduit and can increase the resultant load on the conduit by as much as 50 percent of the weight of the fill above the conduit (i.e., 1.5 times the prism load, which has historically been adopted by the NRCS (2005a)). The trench condition shown in Figure 6.62b occurs when the fill

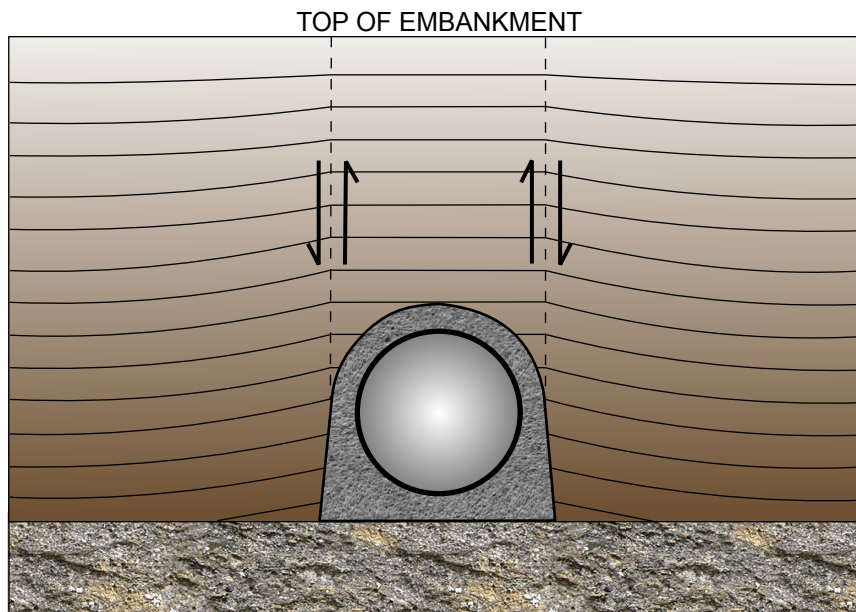

6.62a CONDUIT CONSTRUCTED PRIOR TO FILL PLACEMENT

NOTE: FRICTION FACTORS INCREASE EMBANKMENT LOAD ON THE CONDUIT AS ADJACENT FILL SETTLES MORE THAN EARTHFILL OVERLYING THE CONDUIT.

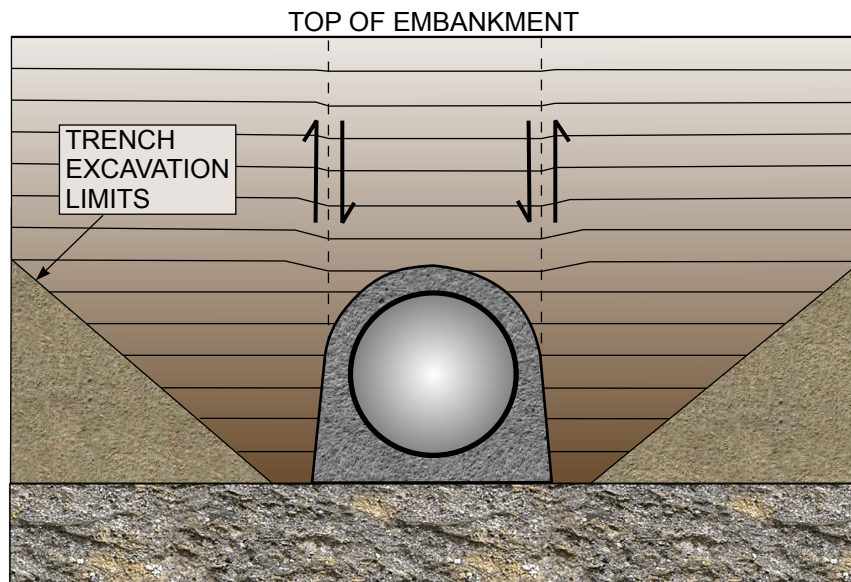

6.62b CONDUIT CONSTRUCTED IN TRENCH EXCAVATED INTO EMBANKMENT

NOTE: FRICTION FACTORS DECREASE EMBANKMENT LOAD ON THE CONDUIT AS FILL OVER CONDUIT SETTLES RELATIVE TO ADJACENT EMBANKMENT.

(ADAPTED FROM FEMA, 2005a)

FIGURE 6.62 DEFORMATIONS ASSOCIATED WITH CONDUITS IN EMBANKMENTS

adjacent to the conduit settles less than the overlying fill. For this case, the differential settlement results in an arching condition that can reduce the load on the conduit by as much as 50 percent of the weight of the fill above the conduit (i.e., 0.5 times the prism load).

FEMA (2005a) recommends that conduits in embankment dams not be installed in trenches with vertical side walls or steep side slopes because a reduction of contact between the fill and the conduit is possible and planes of reduced in-situ stress can develop due to the effects of arching. These phenomena can lead to concentrated seepage paths and conditions more prone to internal erosion of susceptible backfill along and around the conduit. With respect to plastic pipe, FEMA (2007) presents guidance for determining pipe loading (i.e., application of the Marston theory or reliance on the prism load immediately above the pipe) for applications with depths up to about 50 feet and recommends other guidance from pipe manufacturers for situations of deeply buried pipes. FEMA's recommendations are written in the context of earth embankment dams designed for water supply or flood protection. Trench installation of conduits has been successfully employed in the mining industry. However, unnecessarily deep trenches, trenches in potentially unstable ground, and installation details that are difficult to construct within a trench should be avoided. If trench installation of conduits is considered, the backfill should be designed to provide consistent lateral support for the pipe (e.g., through reliable compaction effort or the use of CLSM to enable positive contact of the backfill with the conduit and trench sides). Also, the design of trench installations for flexible conduits should take into account imposed impoundment pressures resulting in external hydrostatic loads and concentrated seepage. The need for a seepage barrier to limit seepage and pressures should be evaluated in conjunction with downstream filter and drainage provisions (e.g., filter diaphragm) along the conduit.

Caution should be exercised when the height of the overburden on a conduit is greater than about 100 feet. Under such fill heights some of the previously mentioned guidance for estimating loads on conduits can result in very high stresses that require inordinately thick conduit walls and/or special reinforcement. More rigorous earth-structure interaction analyses (e.g., finite element methods) may be warranted and/or desirable in such cases and where relatively uniform firm lateral or subgrade support is not present.

The Marston theory is considered to be a very conservative approach for estimating earth loads associated with the conduit fully-projecting condition. However, more sophisticated soil-structure-interaction analytical methods that allow for 2D, 3D, and time-dependent analysis of conduits are available. These methods also allow modeling of the effects of nonlinear, stress-dependent soil (or coal refuse) stress-strain behavior. Computer programs such as CANDE (Culvert ANalysis and DEsign), FLAC (Fast Lagrangian Analysis of Continua) and Plaxis can be used to model excavation, conduit construction, conduit backfilling, and embankment construction over conduits. These programs permit calculation of backfill and conduit stresses and displacements for each stage of construction. They can also be used to evaluate the effects of conduit stiffness, backfill characteristics, foundation movements and other factors that can affect conduit performance and are not considered by Marston theory. Parameters that are typically required for conducting such an analysis include:

- Embankment/fill geometry and unit weight
- Trench geometry
- Undeformed pipe geometry
- Ground/embankment water levels
- Conduit internal water pressure
- Short- and long-term elastic modulus of conduit material
- Compressive strength of conduit material

- Tensile strength of conduit material (metal conduits)
- Geometry, spacing and material properties of reinforcing steel (concrete conduits)
- Bedding factor (concrete conduits)
- Stress-strain properties of compacted backfill envelope (e.g., soil or CLSM) and embankment fill

Concrete conduits are typically designed as rigid structures, whereas plastic and metal conduits are designed as flexible structures. Concrete conduits deflect minimally under load and derive much of their external load capacity from the high strength of the conduit, although bedding and backfill support also contribute to this capacity. Flexible conduits deflect under load and derive their external load capacity from the ability of the conduit to deflect and develop soil support at the sides of the conduit. These very different behaviors must be accounted for during design.

Precast concrete cylinder pipe (RCCP, PCCP) is customarily structurally designed as a rigid conduit by the manufacturer. Internal, external and combinations of loads are applied to a unit length of pipe, and thrusts and moments at various points around the perimeter of the pipe are calculated. The required reinforced concrete design parameters, including concrete thickness, reinforcing steel amount, steel cylinder thickness, and prestress tension, are then determined. Detailed reinforced concrete design procedures with examples for RCCP are provided in Manual M9 (AWWA, 1995). Design procedures, with examples for PCCP, are presented in Standard C304-07, "Design of Prestressed Concrete Cylinder Pipe" (AWWA, 2007).

Thermoplastic and welded steel pipe are designed as flexible structural elements. Internal, external and combinations of loads are applied to a unit length of pipe, and thrusts and moments at various points around the perimeter of the pipe are determined using design guidelines such as *National Engineering Handbook Chapter 52: Structural Design of Flexible Conduits* (NRCS, 2005a). FEMA (2007) has also published a technical manual for plastic pipe used in embankment dams. The NRCS document includes detailed procedures and guidelines for design, inspection, maintenance, and repair of thermoplastic pipe. Detailed design procedures, including the application of methods for evaluating constrained pipe wall buckling, ring deflection, soil reaction modulus, and long-term deflection considerations and limits are provided in engineering manuals prepared by flexible pipe manufacturers (e.g., Performance Pipe, 2003). Additional references include Watkins and Anderson (1999).

Both thermoplastic and welded steel pipe, when backfilled with CLSM or concrete, provide resistance to seepage along the external perimeter of the pipe (FEMA, 2005a). Use of CLSM or concrete encasement, for example, can eliminate the problem of poor backfill compaction in the haunch area of circular pipes. The design of CLSM for pipe support is discussed in [Section 6.6.6.3.3](#). The design of concrete encasement will need to address the structural interaction between the rigid concrete and flexible conduit, and it should demonstrate that the resulting stresses are acceptable.

Because of the critical nature of conduits extending through embankments, careful attention must be paid to construction quality control. Major conduit installation work should be monitored on a full-time basis by a person familiar with the installation requirements. This should include careful monitoring of conduit joint construction and sampling and testing of construction materials. In the post-construction period, major conduits should be periodically inspected (typically through internal camera surveys and, particularly for flexible conduits, inside diameter/deflected shape measurements) to verify acceptable performance of the conduit and to allow early detection of defects and signs of overstressing. Early detection is critical to timely planning and implementation of remedial measures for poorly functioning or distressed conduits. In multi-stage coal refuse disposal facilities, data from monitoring of early stages provides valuable information for projecting or verifying conduit performance under increased fill depths.

The structural adequacy of riser inlets attached to the main conduit barrel should be evaluated. Typically, risers extend upward to relatively shallow depths below the impoundment surface during facility operation and then are decommissioned when no longer needed. Careful consideration should be given to the method of supporting and subsequently capping and decommissioning riser pipes, particularly when the capped riser will eventually be deeply buried. Decommissioned riser pipes represent a potentially weak point in the conduit system. Loads imposed on the riser pipes can be transferred to the main conduit (“barrel pipe”) and cause unacceptable deflection or stress at the location of the riser pipe connection. At present, there are few analytical tools available for analyzing the interaction of deeply buried risers (particularly in cases where the inlet sections are neither vertically nor horizontally oriented) with the surrounding fine coal refuse. Until better analytical tools are available, the support (or encasement) of inlet risers should be carefully evaluated. It may be beneficial to monitor the performance of the riser pipe where it joins the main conduit using internal camera surveys and by making inside diameter/deflected shape measurements at key stages during the life of the facility.

6.6.6.3 Conduit Installation and Design Details

6.6.6.3.1 Installation

Conduits are constructed or installed by placement at or near a level ground surface (embankment condition) or within a trench (trench condition). If the fill adjacent to the conduit settles more than the fill overlying the conduit, which is typical for an embankment installation, downward frictional forces are induced that can increase the load on the conduit by up to 50 percent of the weight of the fill above the conduit. However, if the fill placed directly above the conduit settles more than the adjacent fill, which can happen for conduits constructed in a trench, arching will occur and can reduce the load on the conduit by up to 50 percent of the weight of the fill above the conduit. FEMA (2005a, 2007) presents guidance and recommended limitations for pipe loading and installation conditions for conduits and plastic pipe, respectively, in dams, although other references are applicable for plastic pipe at depths greater than about 50 feet.

Construction of conduits in trenches with vertical side walls or steep side slopes is not recommended (FEMA, 2005a) because a reduction of contact between the fill and the conduit is possible and planes of reduced in-situ stress can develop due to the effects of arching. As noted previously, FEMA’s recommendations are written in the context of earth embankment dams designed for water supply and flood protection. If trench installation of conduits is considered, the backfill should be designed to provide consistent lateral support for the pipe. Also, the design of trench installations for flexible conduits should account for imposed impoundment pressures resulting in external hydrostatic loads and concentrated seepage. Unnecessarily deep trenches, trenches in potentially unstable ground, and installation details that are difficult to construct within a trench should be avoided.

6.6.6.3.2 Rigid Conduit Support

Precast concrete circular pipe should be constructed on concrete or CLSM cradles to eliminate difficulties related to compaction beneath the haunches of the pipe. The cradle should be concrete or higher strength CLSM and should provide vertical, longitudinal, and lateral structural support to the pipe. The cradle should extend for the full length of the pipe and should also extend above the bottom of the pipe at least 25 percent of the pipe outside diameter (i.e., Class A bedding per the American Concrete Pipe Association (1987). A more substantial cradle may be desirable or may be required for enhanced support, especially on soil subgrade. For applications that allow for conduit support on soil, direct or indirect design methods are available (American Concrete Pipe Association, 2007; USACE, 1998a).

The design of the conduit bedding and backfill is dependent upon the compressibility of the foundation and the purpose for which the conduit will be used. Precast concrete pipe should not be used for

pressurized applications in significant- and high-hazard-potential embankments unless measures are taken to address the potential impact of failure of a pipe joint or joint gasket and resulting leakage of pressurized water into the embankment. Conduits should be constructed on rock or firm foundations whenever possible. If a pipe is founded on a compressible foundation, the design should accommodate the anticipated magnitude and distribution of settlement, because settlements can lead to joint failure.

Many approaches have been used to design rigid conduits on compressible foundations. A preferred approach utilizes a joint design for the cradle that allows articulation and spreading of both the pipe and the cradle. Cradle joints are placed at the locations of the pipe joints, and cradle reinforcement is not allowed to pass through the joints. Spaces between joints are filled with a compressible material, such as high-density sponge rubber or bituminous fiberboard, to keep extraneous material out of the joints and allow articulation. USDA (1958) provides design guidelines for pipe cradles.

A concrete cradle should bond to the conduit. In embankment installation configurations, the cradle should extend at least 4 inches beyond each side of the pipe, and the sides of the concrete cradle should always be sloped at 1H:10V or flatter through low-hydraulic-conductivity zones to allow construction equipment to compact earthfill directly against the cradle. There should be no sharp or protruding corners associated with the cradle that could cause undesirable stress concentrations in the fill. Measures should be taken to support the conduit on grade until the concrete cradle has been placed and cured.

Concrete bedding and cradles beneath circular conduits are typically designed to reach about 25 percent of the conduit outside height in order to provide support to the conduit and to facilitate compaction under the haunches. The bedding is often constructed with joints opposite the circular conduit joints so as to not interfere with potential conduit movement. Guidance for the use of bedding in conjunction with fully circular pipes is provided in USDA (1958) and USACE (1998a). The choice of whether to use cradles or bedding is typically a function of the height of the embankment, quality of the subgrade and the benefits gained from using a cradle versus bedding in reducing the structural requirements for the pipe. Cradles are often used in higher embankments where more lateral support is required. Regardless of whether a cradle or bedding is used, seepage control measures such as filter diaphragms should be employed, even for low-hazard-potential embankments and favorable conditions. A discussion of seepage control measures along conduits is provided in [Section 6.6.2.3.3](#).

6.6.6.3.3 Flexible Conduit Support

As discussed in Section 6.6.6.1, the use of HDPE pipe at coal refuse disposal facilities has become prevalent. Concrete cradles and bedding are not generally used for flexible pipe installations because flexible pipes require some deflection to develop resistance from the surrounding backfill, and cradles and bedding limit this deflection. Thus, if flexible pipe is constrained by a rigid cradle, it may become overstressed. Therefore, HDPE pipe should not be supported or constrained by a rigid cradle or encased in normal-strength concrete that will limit the flexible pipe from deforming in its intended manner. However, HDPE pipe may be used as a liner within a structural encasement if the system is properly designed as a rigid conduit, with appropriate stiffness capable of withstanding potential external hydrostatic loads, and the heat of hydration of the concrete and wall thickness of the HDPE liner are balanced to limit the potential for separation of the liner from the encasement. Simply encasing a plastic liner pipe in concrete will not necessarily preclude development of significant hydrostatic pressure at the interface between the liner pipe and encasement. The potential for external hydrostatic loading is further addressed in FEMA (2007).

As an alternate to compacted soil backfill, flowable or controlled low-strength material (CLSM) backfill has been successfully used to provide support and encasement of flexible conduits. For plastic conduits, the flowable backfill/CLSM should be designed to have a relatively low cement content

(low unconfined compressive strength), but have substantial fractions of fine aggregate and pozzolan so that a mix design with a soil-like matrix, low heat of hydration, limited shrinkage potential, and relatively low hydraulic conductivity is achieved. As described in Section 6.5.10.2, flowable backfill consists of cement and other pozzolans (e.g., fly ash), sand and water. The target strength should be that of a very stiff to hard soil (in the range of 50 psi to 200 psi maximum) so that the conduit-backfill system behaves as intended. Mixes designed to produce a compressive strength much lower than 50 psi may not have sufficient cement content to produce a conduit backfill with uniform characteristics (e.g., strength and compressibility) and erosion and weathering resistance. Pre-testing of prospective flowable backfill mixes is recommended so that a flowable material with relatively uniform strength and stiffness properties is achieved.

The hydraulic conductivity of the flowable fill material should be less than or equal to the hydraulic conductivity of the adjoining portions of the embankment. The addition of a small percentage of bentonite or attapulgite to the CLSM mix is an option in cases where a hydraulic conductivity much lower than 10^{-5} cm/sec is desired or required. For conduit installations in embankment dams, measures should be in place to intercept and drain potential seepage along the conduit. Typical measures include filter diaphragms, as described in Section 6.6.2.3.3. FEMA (2007) has expressed caution about the use of CLSM in significant- and high-hazard-potential embankment dams, pending research to evaluate its performance. As noted previously, FEMA's concerns are presented in the context of earth embankment dams designed for water supply and flood protection. CLSM backfill installations of conduits are becoming more common for embankments used in transportation infrastructure and in the mining industry, and they are attractive because they provide effective support while addressing seepage issues.

The reaction modulus for CLSM backfill should be selected based on the mix design, as discussed above, and available test data (e.g., unconfined and uniaxial compressive strength tests), conservatively considering the CLSM to be equivalent to a very dense sand or gravel material. For deep conduit installations, the influence of earthen materials adjacent to the CLSM may also need to be incorporated into the evaluation of deflection and buckling. When used in the modified Iowa Formula for buried pipe deflection calculations, the reaction modulus is analogous to the soil reaction modulus E' (Howard, 1977). Flowable fill employing a mix design to achieve a minimum 50 psi at 28 days, and incorporating the recommendations presented in Section 6.5.10.2, would presumably have a reaction modulus equal to or greater than highly compacted granular backfill given its compressive strength and low compressibility. Modeling based on testing of such mixes by McGrath and Hoopes (1998) determined an E' of 3,000 psi after 28 days for CLSM with high air content. Reaction modulus values as high as 3,800 psi have been applied in the past for embankment dams in the mining industry and have yielded reasonably good predictions of actual deflections for deeply-buried, thick-walled HDPE pipe. However, the actual width of flowable fill on each side of the pipe installation relative to the pipe diameter and the consistency of the native sidefill soil or trench wall will influence the extent to which the flowable fill support/reaction predominates over the support/reaction of the sidefill soil or trench wall (as applicable).

Note that the modified Iowa Formula and the recommended modulus of soil reaction E' values for application in the formula were developed from data on pipe installations up to about 50 feet deep, presuming that the prism load acts on the buried conduit. Therefore, for burial depths up to and somewhat greater than 50 feet, the prism load and recommended limiting soil reaction values should be adopted when applying the modified Iowa Formula. However, for burial depths much greater than 50 feet, if the vertical load on the conduit is truly increasing in proportion to the fill height, it follows that there would be some attendant increase in the soil reaction modulus. Currently, guidance for quantifying a soil reaction modulus or reaction modulus of non-soil backfill for simplified analysis of deeply buried conduits is limited.

6.6.6.3.4 Watertightness

If the joints between conduit sections separate or deteriorate, the conduit may develop leaks that can lead to internal/backward erosion (piping) failure mechanisms. Accordingly, government agencies such as the USACE and the Bureau of Reclamation require that joints in conduits in embankment dams be watertight (FEMA, 2005a). The degree to which joints must be watertight depends on the anticipated hydrostatic head both inside and outside of the conduit. As shown in Figures 6.63 and 6.64, RCCP and PCCP employ a rubber gasket confined between steel spigot rings and mastic in the joints to provide a waterstop. The watertightness of HDPE conduit is achieved by fuse welding the conduit joints. Similarly, the watertightness of steel conduit is achieved by welding the conduit joints. Details related to conduit joint construction and measures for achieving watertightness are provided in FEMA (2005a).

Conduits constructed on compressible foundations are vulnerable to joint spreading. Special attention should be given to evaluating the compressibility and shear strength of materials in compressible foundations. Section 6.6.3 provides a discussion of methods for predicting settlement. Technical Release 18 (TR-18) published by the USDA (1969) uses the predicted vertical strain beneath a conduit, the shear strength of foundation soils, and the geometry of the embankment and foundation to predict horizontal strain in the conduit. If the joints between the ends of conduit sections separate or develop other defects, a conduit may develop leaks. This leakage can lead to the development of internal erosion or backward erosion piping failure mechanisms.

Excessive lateral movement of an embankment/foundation system can occur when thin weak layers in the foundation are loaded beyond their shear strength. These movements may result in slope instability, and they can also cause damage to a conduit if it is located over the weak layer. Slope flattening and berms can be used to prevent such movements, but these remedies will result in a longer conduit. To minimize differential settlement and movement of conduit joints, foundations under conduits should have relatively uniform compressibility characteristics.

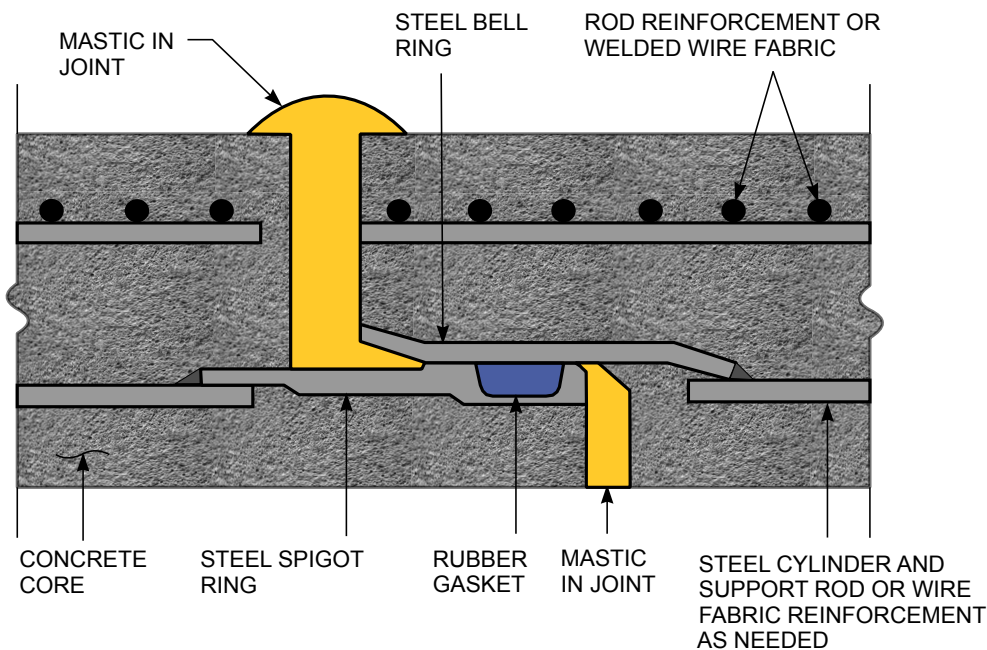

(FEMA, 2005a)

FIGURE 6.63 REINFORCED CONCRETE CYLINDER PIPE (RCCP) DETAILS

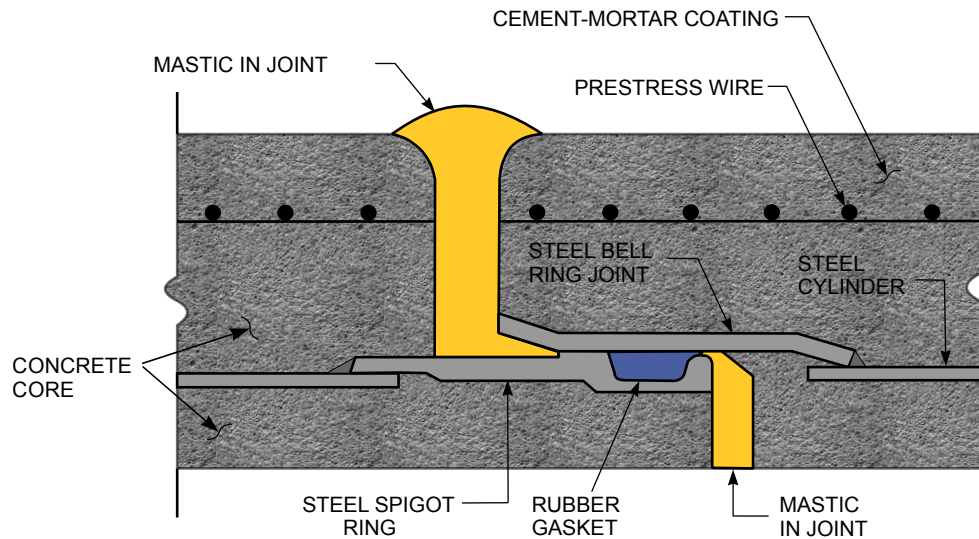

(FEMA, 2005a)

FIGURE 6.64 PRESTRESSED CONCRETE CYLINDER PIPE (PCCP) DETAILS (LINED CYLINDER)

Variable foundation conditions can result in abrupt changes in conduit settlement that can lead to large relative movements and failure. A properly designed joint will limit vertical and transverse displacement of conduit sections relative to each other as an embankment settles and will also accommodate rotation and longitudinal movement while maintaining watertightness. For conduits on a compressible foundation, the maximum potential joint elongation that may occur as a result of the compressibility of the foundation should be determined as accurately as possible. The potential joint elongation is a function of:

- Shear strength of the foundation
- Estimated settlement of the foundation
- Configuration of the embankment dam
- Lengths of conduit sections

If the predicted elongation exceeds the magnitude that the joints can accommodate, design changes such as using shorter lengths of conduit, replacing compressible foundation soils with compacted backfill, and flattening the slopes of the embankment should be considered.

Embankment settlement may not always be as predicted by analyses and can sometimes vary over relatively short distances, resulting in abrupt joint displacements. Figure 6.65 illustrates that measured settlement can be significantly different from the calculated settlement. These variations in actual settlement can lead to joint displacements. Abrupt joint displacements are generally more likely for conduits that are constructed using precast concrete pipe than for conduits constructed with RCCP or PCCP. The reason for the difference is that RCCP and PCCP conduits are constructed with longitudinal reinforcement extending through the joints, allowing the conduits to bridge over weak foundation areas and to spread the effects related to variation in settlement. Welding of the conduit joints for HDPE and steel pipe results in higher strength and strain characteristics and increased resistance to distress caused by abrupt displacement. However, conduit foundations should be designed to provide uniform support.

Special precautions should be taken at joints where conduits connect to structures. The joint between an intake structure and a conduit is susceptible to differential settlement because of the potential

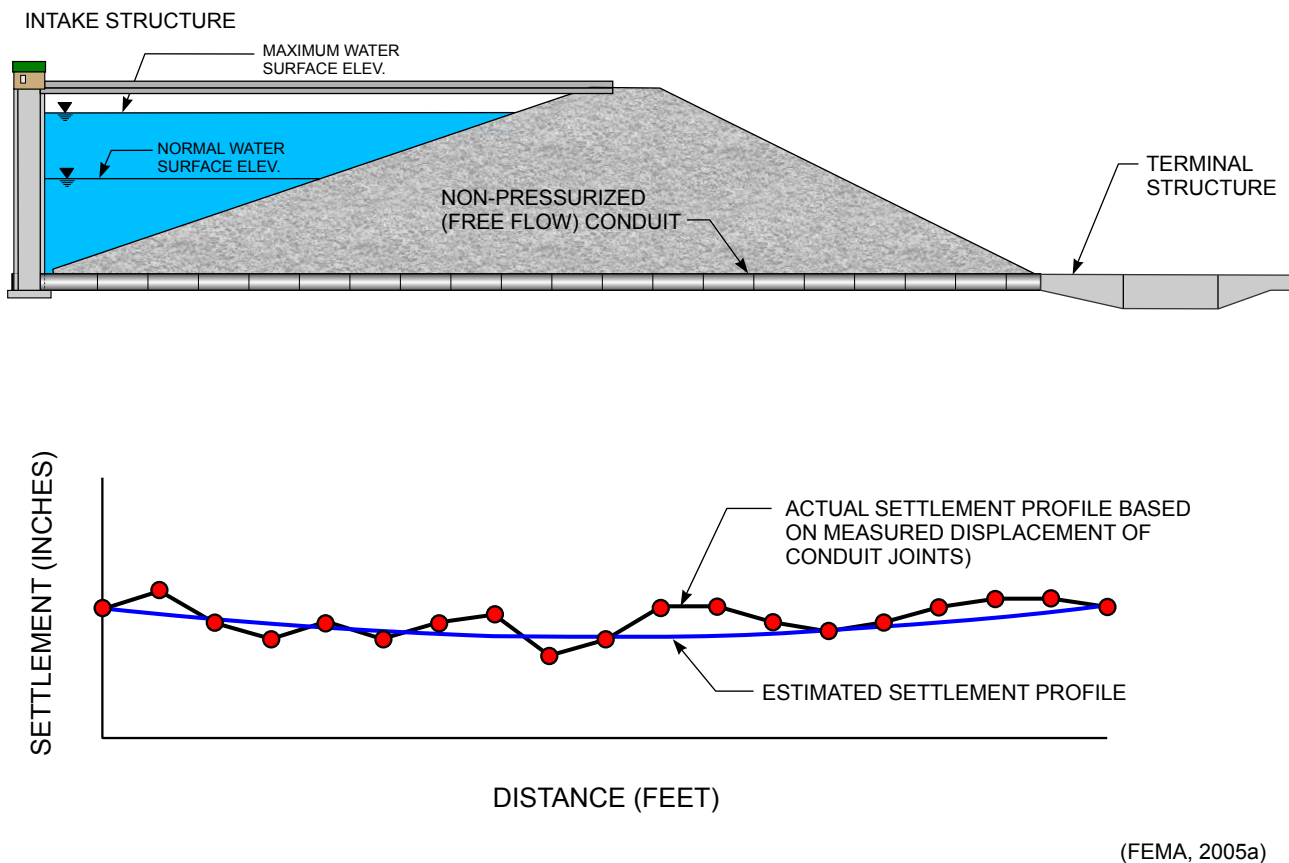

FIGURE 6.65 COMPARISON OF PREDICTED AND OBSERVED CONDUIT SETTLEMENTS

disparity in the weights and foundation conditions between the two structures. If both structures are constructed over relatively soft materials, the intake structure will tend to settle much more than the conduit. If the intake structure is constructed over engineered fill of low compressibility or on deep foundation elements, the conduit may tend to settle more than the intake structure. Either situation can lead to excessive deformation of the conduit joints in the vicinity of the intake structure. Under such circumstances, provisions to allow for relative movement may need to be incorporated into the design.

6.6.7 Blasting Impacts

Blasting must be conducted in such a manner as to prevent injury to site personnel and unacceptable impacts to structures associated with a coal refuse disposal facility, including refuse or earthen embankment dams and their impoundments. Impacts to off-site structures and properties must also be limited in accordance with applicable guidelines. Typically, embankment dams have very low natural frequencies (on the order of 1 hz) and thus are not particularly susceptible to damage due to blast vibrations, which have a much higher frequency range. If it is believed that blast effects could have a deleterious effect on site structures (such as for embankments developed by the upstream construction method), the impact of ground motion for the anticipated magnitude and frequency range of blast vibrations can be considered using the procedures for seismic stability described in Chapter 7. Some structures associated with fresh water dams, such as large concrete spillway channels, tall riser intake structures or pipelines under low confinement could possess natural frequencies similar to blast frequencies and thus be impacted by blasting. However, typical concrete structures and pipelines used at coal refuse facilities are normally not very susceptible to damage from blasting vibrations.

Structures are affected by blasting in relation to the peak particle velocity and frequency content of the ground motion induced by a blast. Simplified relationships are commonly used to determine

the charge size relative to the horizontal distance to the monitoring point in order to meet acceptable motion (velocity) criteria. One such relationship for the peak particle velocity V resulting from a blast is (ISEE, 1998):

$$V = K(D/W^{0.5})^{-1.6} \tag{6-33}$$

where:

- K = site-specific constant determined from calibration test
- D = distance to blast (length)
- W = weight of charge (force)

Topographic and geologic variations between the blast location and observation point and the position of the blast horizon relative to the foundation of the structure can significantly affect the attenuation or amplification of blast-induced ground motions.

Acceptable vibration criteria are published in a number of sources: state regulatory programs typically provide guidance for peak particle velocity for common structure types, and general guidance can be found in Nichols et al. (1971), Siskind et al. (1980), ISEE (1998), and Hartman (1992). Blasting for excavation of rock materials is generally controlled to a peak particle velocity (PPV) of 4 inches per second for mass concrete structures (Hartman, 1992) and to 2 inches per second for typical steel and concrete superstructures. Notably, these PPV thresholds are generally very conservative and correlate to the possible onset of visible cosmetic damage. The noted structure types can typically tolerate much higher PPVs before structural damage occurs. Table 6.57 provides additional information on levels of damage to houses for specific particle velocities, and Figure 6.66 shows acceptable limits of vibration for houses, as recommended in Siskind (1980).

When blasting is planned within 500 feet of an active underground mine, the Surface Mining Control and Reclamation Act of 1977 requires approval of an operator’s blasting plan by OSM, or the appropriate state agency, and MSHA. Blasting regulations are provided in 30 CFR § 780.13 and 30 CFR §

TABLE 6.57 COMMON RESIDENTIAL VELOCITY CRITERIA AND EFFECTS

Velocity	Damage Level
0.5 in/sec	Recommended limit to prevent threshold damage in plaster-on-lath construction near surface mines due to long-term, large-scale blasting operations (USBM, 1980).
0.75 in/sec	Recommended limit to prevent threshold damage in sheetrock construction near surface mines (USBM, 1980).
1.0 in/sec	Office of Surface Mining (OSM) regulatory limit for residences near surface mine operations at distances of 300 to 5,000 ft (long-term, large-scale blasting).
2.0 in/sec	Widely accepted limit for residences near construction blasting and quarry blasting. Also allowed by OSM for frequencies above 30 hz (USBM; 1971, 1980).
5.4 in/sec	Minor damage to the average house subjected to quarry blasting vibrations (USBM, 1971).
9.0 in/sec	About 90 percent probability of minor damage from quarry blasting. Structural damage to some houses, depending on vibration source, characteristics and house construction.
20.0 in/sec	For close-in construction blasting, minor damage to nearly all houses, structural damage to some. For low-frequency vibrations, structural damage to most houses.

(ADAPTED FROM ISEE, 1998)

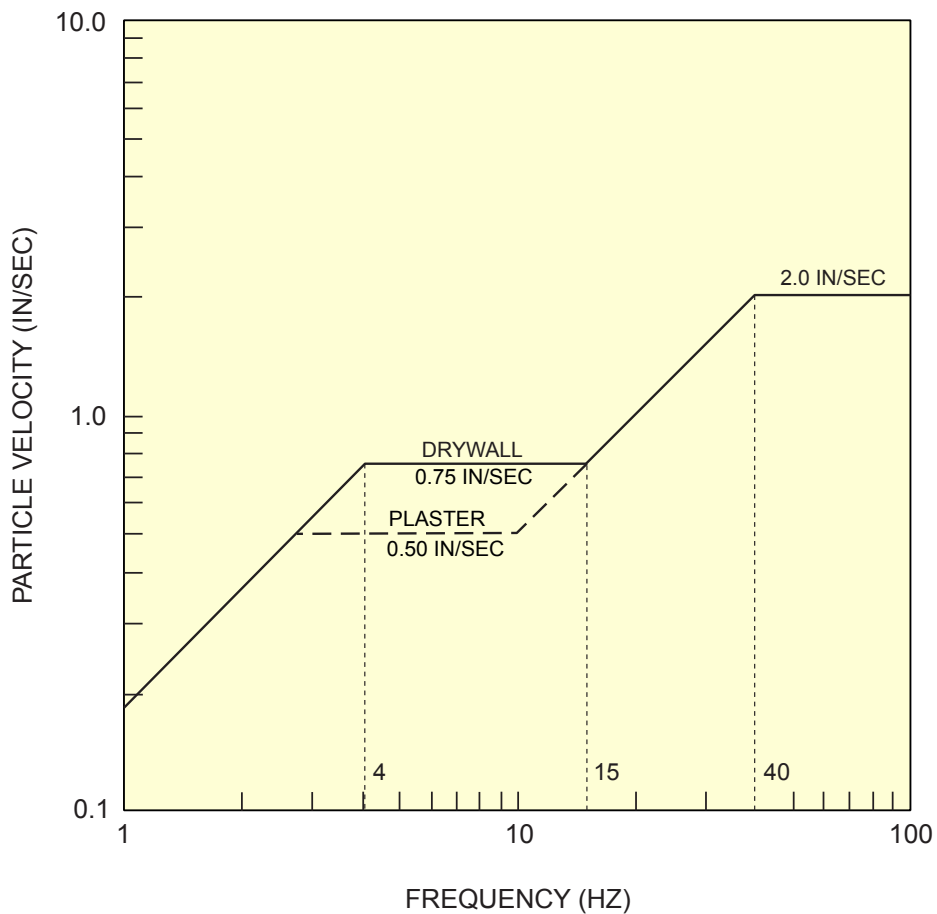

(ADAPTED FROM SISKIND ET AL., 1980)

FIGURE 6.66 ACCEPTABLE LIMITS OF VIBRATION FOR HOUSES

816.61 through 816.68 and 816.79. State criteria may also be applicable. The blasting plan should be prepared by a professional licensed in the state where the blasting is to be performed. Potential concerns when an impoundment is present include fracturing of abutments, impacts to pipes and other rigid structures, and possibly impacts to upstream construction. The potential impacts should be evaluated, and monitoring of particle velocity with a seismograph may be appropriate. Monitoring of specific structures and features may be warranted and could include inspection of impounding embankment crests and slopes for evidence of cracks or displacements, review of piezometer data for evidence of water level fluctuations, and observation of concrete joints or crack apertures to verify the general integrity and to note any movements.

Chapter 7

SEISMIC DESIGN: STABILITY AND DEFORMATION ANALYSES

7.1 GENERAL

7.1.1 Design Approach

Under certain conditions, seismic loadings from an earthquake or other source can cause embankment or foundation materials to lose strength, potentially causing a structure to become unstable. Coal refuse embankments constructed using the upstream construction method may be particularly susceptible to instability from an earthquake because a portion of the dam is constructed on soft or loose saturated, hydraulically-placed material. Designers should perform an evaluation (commensurate with the hazard potential of the structure) to confirm that dam and embankment designs provide an adequate margin of safety against seismically-induced instability.

The methods of exploration, testing, and analysis presented in this chapter are based on research and practice, publications, and experience on a variety of projects. They provide a variety of options for design. These methods, ranging from basic to sophisticated, have generally been applied on coal refuse disposal sites. Commentary is provided in the text to help explain the basis for the methods and the applicability of the methods to specific situations. It is recognized that refinements in the methods, as well as new methods, may be developed in the future. Designers are encouraged to evaluate such refinements, new methods, and other approaches that are technically sound, particularly if they better address site-specific materials or conditions. Designers are also cautioned that this subject is complex and that refinements of existing methods and development of new methods can require substantial research and investigation, as well as input from geologists, seismologists, geotechnical engineers, and other professionals.

This chapter refers to dams and embankments interchangeably. Also, references to “soil” or “material” encompass soils and coal refuse materials (e.g., fine coal refuse or tailings, filter cake, combined coal refuse, mixed refuse, coarse coal refuse, and amended refuse). As there have been no reported failures of coal refuse embankments due to seismic loading within the U.S. coalfields, the various studies of strength loss due to seismic loading are predominantly from sites that contain natural soils or other mine tailings. Thus, the physical behavior of coal refuse materials must be inferred from correlations, supported by laboratory testing.

The following published papers, studies and ongoing research on coal refuse materials and seismic design of disposal sites provide an overview of information specific to slurry impoundments and potential information on testing and parameters that may be available:

- Gardner and Wu (2002) present an overview of challenges in evaluating strength loss at coal refuse disposal facilities from MSHA's perspective. They summarize the available pore-pressure-based empirical methods (field standard penetration testing and cone penetration testing) and strain-based laboratory methods (undrained steady-state shear strength approach based on triaxial compression tests) for evaluation of potential strength loss at coal refuse disposal impoundments.
- Castro (2003) presents the undrained peak strengths and undrained steady-state strengths derived from cone penetration testing, field vane-shear tests, laboratory tests on undisturbed samples and laboratory-consolidated slurry samples. These strength data show that strength loss of fine tailings is noticeable and the undrained steady-state strength values are typically between one-half and one-fourth of the peak undrained strength. The paper also provides cyclic-triaxial test data for undisturbed samples of natural clayey silt of low plasticity, similar to fine tailings, to show the degradation of peak undrained strength with strain during cyclic loading.
- Genes et al. (2000) present the undrained steady-state shear strength approach for evaluation of strength loss at five coal refuse disposal facilities in West Virginia. Isotropically-consolidated, undrained triaxial compression tests of undisturbed and remolded samples of fine coal refuse from five different disposal sites are presented to show undrained steady-state shear strength variation with void ratio and effective vertical stress.
- Ulrich et al. (1991) present a pore-pressure-based evaluation using cyclic-triaxial tests on samples of fine coal refuse from sites in Kentucky, Ohio, and Tennessee.
- Cowherd and Corda (1998) discuss pore-pressure-based empirical methods for triggering of strength loss at coal refuse dams and provide standard penetration tests data along with the measured seismic shear wave velocities for fine coal refuse, with a summary of cyclic-triaxial test results from four disposal sites.
- Hegazy et al. (2004) presents engineering properties for northern Appalachian coal refuse, including a summary of results of seismic piezocone testing and field vane-shear testing used for determining undrained shear strength.
- Kalinski and Phillips (2008) present a progress report on research being conducted at the University of Kentucky concerning development of dynamic properties of coal refuse. When completed, it will include field and laboratory testing on the dynamic behavior of coal refuse materials. Field standard penetration testing, cone-penetration testing, field vane-shear testing, seismic surface-wave testing, and downhole-seismic testing are to be performed. Complementary laboratory cyclic-triaxial testing and resonant-column testing are also proposed for determining dynamic properties of coal refuse materials.
- Zeng and Goble (2008) present the results of laboratory testing (resonant-column and cyclic-triaxial tests) for determining dynamic properties (damping ratio and shear modulus) performed on Appalachian coal refuse at Case Western Reserve University.

Seismic design of dams and embankments involves two separate requirements:

1. Prevention of seismic instability (slides)
2. Prevention of excessive deformations (translation, settlement, and cracking)

7.1.1.1 Seismic Instability

The ground motion from an earthquake can result in a reduction in the shear strength of loose, saturated materials. Seismic instability may occur when post-earthquake shear strength is less than the

pre-earthquake shear strength in one or more significant zones of an embankment or foundation. The driving force of the seismic instability is the static (gravity) weight of the embankment. Seismic instability is a particular concern for dams with substantial upstream construction because a portion of the dam is constructed on hydraulically-placed fine material. For seismic instability to occur, three conditions must develop:

1. The earthquake shaking must be strong enough to trigger undrained strength loss in one or more zones of material.
2. The strength loss must be significant enough that the post-earthquake shear strengths are less than the static driving shear stresses.
3. The location and amount of the material that experiences strength loss must be sufficient to generate instability.

Seismic stability is generally analyzed as a static (i.e., no seismic coefficient) limit-equilibrium, slope-stability problem, using post-earthquake shear strengths for the materials in the embankment and foundation. The earthquake shaking causes the material in the embankment or foundation to lose strength, but the static gravity shear stresses drive the failure. Some instability failures have been observed to occur after the earthquake shaking has stopped (Seed et al., 2003; Seed and Harder, 1990; Marcuson, Hynes and Franklin, 1992).

Experience has shown that when significant strength loss occurs in critical sections of a structure: (1) failures are often rapid, (2) they occur with little warning, and (3) the resulting deformations are often very large. Experience has also shown that the trigger events can be quite small. Hence, seismic design for significant- to high-hazard-potential dams and embankments should be carried out with caution and care.

7.1.1.2 Excessive Deformations

If seismic stability analyses indicate that an embankment is unstable, then deformations should be considered to be unacceptably large. However, if seismic stability analyses indicate that an embankment is stable, then potential seismic deformations should be assessed. Seismic deformations occur primarily during earthquake shaking. The cyclic-shear stresses induced by the earthquake contribute directly to the deformations. This contrasts with the primary mechanisms of instability. In seismic instability, the earthquake shaking causes undrained strength loss, but the static gravity stresses drive the instability failure.

The material making up the dam or embankment, the fine coal refuse or tailings retained behind and sometimes underlying the embankment, and the natural soil below the embankment must all be evaluated as part of stability and deformation analyses.

The basic elements for seismic design and analysis require evaluation of:

- Susceptibility of materials to strength loss and post-earthquake strengths
- Seismic stability using post-earthquake strengths
- Whether the design earthquake will trigger strength loss
- Deformations

7.1.2 Seismic Design Considerations and Flow Chart

The following points were considered in developing the guidance and recommendations presented in this chapter:

- The levels of analysis that should be performed vary depending on the type of facility and the consequences of failure. So, for example, no seismic analysis is required for low-hazard-potential dams (provided static stability is satisfied), while seismic stability and deformation analyses are required for high-hazard-potential dams.
- Methods for evaluating the susceptibility of a material to strength loss during an earthquake and for evaluating the degree of strength loss depend partly on whether the material is sand-like or clay-like. Fine coal refuse within a structure, and natural soil deposits in the foundation, might include zones of both sand-like and clay-like material. Therefore, methods for evaluating both sand-like and clay-like material are provided. These methods apply to both coal refuse materials and soil.
- Straightforward screening methods should be available for differentiating zones that are potentially susceptible to seismically-induced strength loss from zones that are not susceptible. Further detailed investigation and evaluation can then be focused on the potentially-susceptible zones. This chapter presents screening methods for both clay-like and sand-like material that require only the basic information provided by Standard Penetration Test (SPT) or Cone Penetration Test (CPT) data, grain-size test results, and Atterberg-limit data.
- Relatively straightforward methods of analysis should be available to designers, as well as methods that are more sophisticated. The more sophisticated methods may allow for less conservatism in the design and might be worthwhile for achieving a more economical design. However, the more sophisticated methods are optional, not required. For example, relatively straightforward field testing methods can be used to estimate post-earthquake strength, as well as more sophisticated, optional, laboratory methods. Another example is that seismic-stability analyses can be performed by simply assuming that the design earthquake triggers strength loss in materials that are potentially susceptible to strength loss, or an optional triggering analysis can be performed to evaluate whether the design earthquake is in fact strong enough to trigger strength loss. The authors of this chapter note that triggering analyses are not considered to be appropriate for sand-like materials for design earthquakes that exceed certain criteria and therefore impose significant seismic stresses on the materials. In designing new structures, it is often prudent to design based on the relatively straightforward methods rather than using more sophisticated methods to justify a design.
- The level of detail required for evaluation of the seismicity of a site should depend on the level of seismic hazard at the site. Many coal mining regions in the U.S. are in areas of low seismic hazard. Minimum parameters for the design earthquake in these areas are provided, and a site-specific evaluation is not recommended. For sites in areas of higher seismic hazard, a site-specific seismicity evaluation is recommended.
- The various credible methods employed by geotechnical engineers experienced in the seismic design of dams should be available for use. Therefore, this chapter presents three methods for analyzing the triggering of strength loss in loose, sand-like material: (1) the pore-pressure-based approach developed by Seed and updated by Youd et al. (2001), (2) the strain-based approach developed by Castro (1994), and (3) the stress-based approach developed by Olson and Stark (2003). Several field and laboratory methods and correlations for estimating post-earthquake strength of materials that are susceptible to strength loss and several methods for performing deformation analyses are also presented.
- Structures should generally have a safety factor of at least 1.2 for seismic stability based on a static stability analysis using post-earthquake material strengths. This safety factor is intended to account for uncertainties in the geometry of the structure,

in the shear strength, and in the delineation of zones that are potentially susceptible to strength loss, and it also helps achieve designs for which predicted seismic deformations are within acceptable limits.

- There may be special cases involving existing facilities for which the recommended design criteria can be relaxed. Examples of these special cases include minor modifications made as part of closure activities in which the progress toward closure will eventually improve seismic stability, and interim improvements for addressing a specific existing deficiency (e.g., adding an interim stage to provide needed free-board).

The recommended steps for a seismic evaluation or design are illustrated in the flow chart presented in [Figures 7.1a, 7.1b](#) and [7.1c](#). These steps are described in detail in [Section 7.4.4](#). A relatively straightforward path through the seismic stability portion of the flow chart (in which triggering analyses, sophisticated laboratory testing, and seismicity evaluations are avoided) is described in [Section 7.1.5](#).

The steps in the flow chart in [Figure 7.1a](#) can be summarized as follows:

1. Classify the structure and foundation based on type, size, downstream hazard potential, and anticipated performance under seismic loading, per the criteria indicated in Boxes 1, 2, and 3 of the flow chart.
2. Considering the classification in Step 1, and a conservative evaluation of post-earthquake stability (optional, Boxes 5 and 6), categorize the structure and foundation as either (1) further seismic evaluation is not needed (go to Box 4) or (2) potentially susceptible to seismic instability such that additional analysis is required (go to Box 7).
3. For those structures that are potentially susceptible to seismic instability, thoroughly characterize the soils and refuse in the structure and foundation (Box 7 of flow chart and [Section 7.3](#) of text). This step generally requires a significant effort because the spatial distribution of the refuse materials can be variable. Identify zones in the structure and foundation that may be susceptible to strength loss due to earthquake shaking ([Section 7.4.4.2](#)).
4. Analyze the stability of the embankment using post-earthquake strengths ([Section 7.4.3](#)). Post-earthquake strengths will be lower than pre-earthquake (static) strengths for zones that are susceptible to strength loss. This analysis may be relatively straightforward based on field testing data and laboratory index testing (Boxes 7, 7A, and 8). At coal refuse disposal sites where the ratio of coarse to fine refuse is large enough to allow design of massive (wide) embankments with broad crests, employing the basic and more straightforward methods are recommended because of their relative simplicity in design and regulatory review and their conservatism. Alternatively, sophisticated laboratory testing can be used to provide better estimates of post-earthquake strength, and relatively complex triggering analyses can be performed to evaluate whether the earthquake shaking is actually strong enough to trigger strength loss in the materials that are potentially susceptible to strength loss (Boxes 9 through 16 and [Sections 7.4.2](#) and [7.4.3.2](#)). A seismic hazard evaluation ([Section 7.7](#) and [Figure 7.23](#)) may be needed as part of these more sophisticated testing and analysis methods to define the magnitude and peak ground acceleration of the design earthquake and to obtain representative time histories of acceleration. These more sophisticated testing and analysis methods are often less conservative than the basic and more straightforward methods. The added costs of the more sophisticated testing and analysis may be justified by designs that are more economical or more efficient from an operational standpoint.

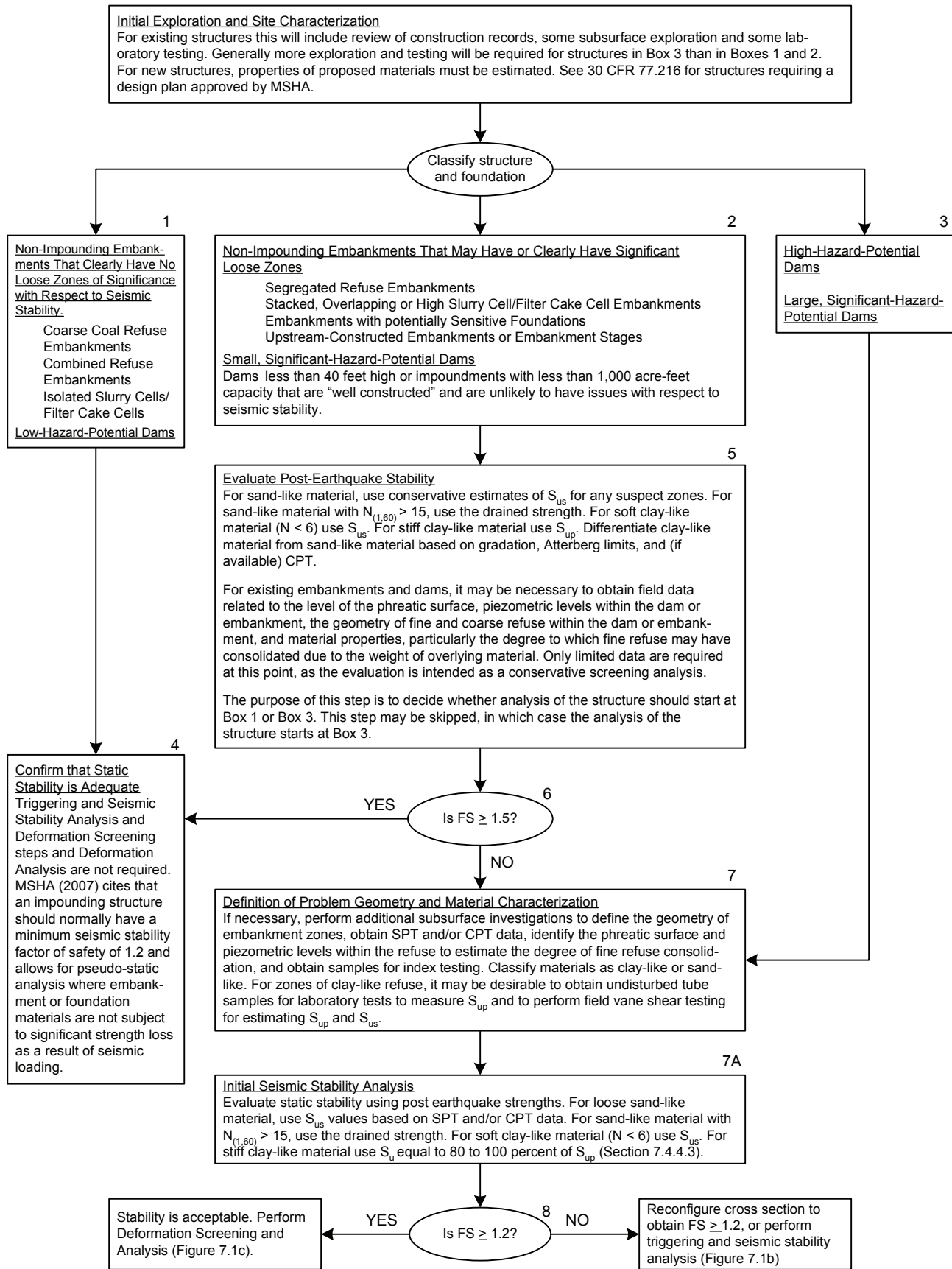

FIGURE 7.1a SEISMIC STABILITY SCREENING

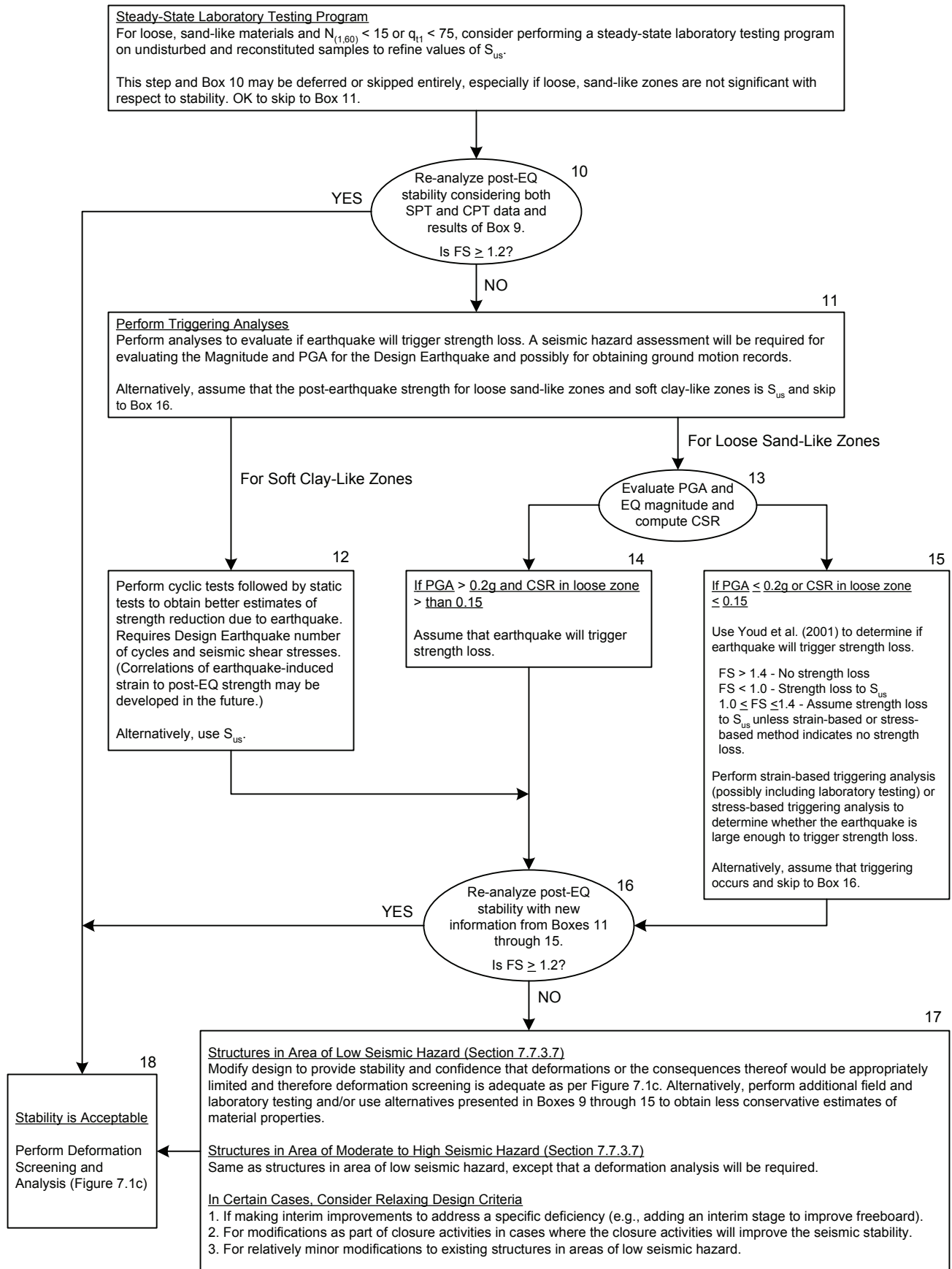

FIGURE 7.1b TRIGGERING AND SEISMIC-STABILITY ANALYSIS

DEFORMATION SCREENING

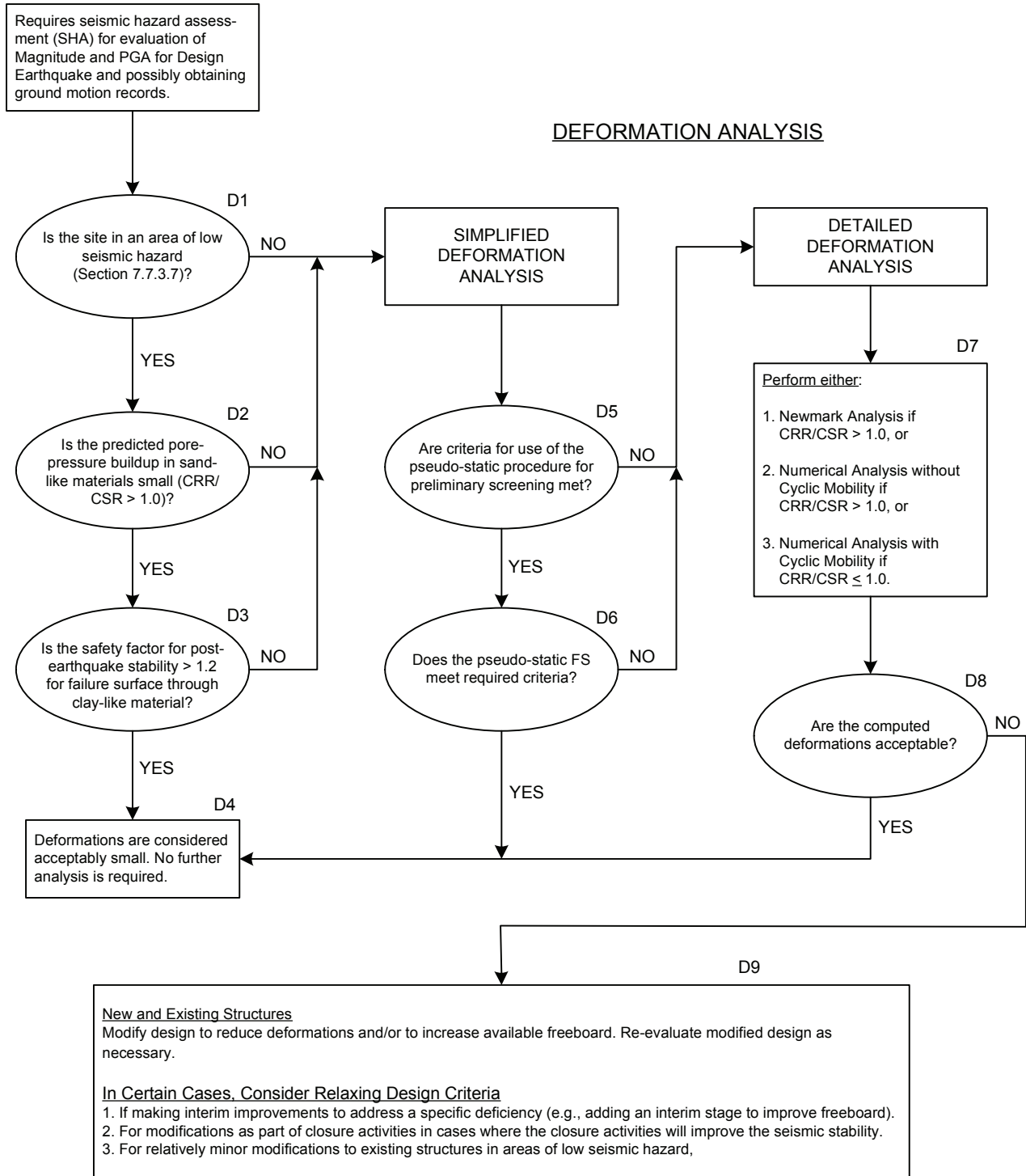

FIGURE 7.1c DEFLECTION SCREENING AND ANALYSIS

5. If stability is acceptable (safety factor of 1.2 or higher), evaluate potential deformations (Step 7).
6. If stability is not acceptable, redesign or modify the embankment until stability is acceptable (Box 17).
7. Evaluate potential deformations of the embankment caused by the earthquake shaking (Boxes D1 through D8 and [Section 7.5](#)). The deformation analysis may involve a

relatively simple screening analysis or may require sophisticated computer modeling. If not performed as part of Step 4, a seismic-hazard evaluation (Section 7.7 and Figure 7.23) will be needed as part of the deformation analysis.

8. If the estimated deformations are within an acceptable range, accept the design. Otherwise, redesign or modify the embankment (Box D9).

7.1.3 Sand-Like Versus Clay-Like Material

For many of the analyses described in this chapter, fine coal refuse and natural soils are referred to as sand-like or clay-like depending on whether they exhibit monotonic and cyclic undrained shear loading behavior that is fundamentally more similar to that of either sand or clay. The methods for evaluating susceptibility to strength loss, triggering, and post-earthquake strength are different for sand-like and clay-like materials. This differentiation is significant primarily if the material is loose enough (sands) or soft or sensitive enough (clays) that it is potentially susceptible to strength loss.

The key factors in differentiating loose sand-like material from soft or medium clay-like material, for the purposes of seismic stability and deformation analyses, are the strain at peak undrained strength and the abruptness of the drop-off in shearing resistance as strains increase beyond the strain at peak. Loose sands and highly sensitive clays can reach peak undrained strength S_{up} at small strains, and experience abrupt drop-off in resistance at higher strains. Most clays tend to reach S_{up} at higher strains, and tend to experience more gradual and limited drop-off in shearing resistance at higher strains. Fine coal refuse deposits often include materials falling within both classifications, and near the boundary of these two types of behavior.

Loose material with shear strain at peak strength of less than 2 percent in an undrained monotonic (non-cyclic) test, and a rapid drop-off in resistance after reaching peak strength, is generally considered sand-like (although highly sensitive clays may exhibit similar behavior). Loose or soft material with shear strain at peak strength of more than about 5 percent, and a gradual drop-off in resistance after reaching peak strength is considered clay-like. Figure 7.2 illustrates the associated stress-strain curves for these materials. Material with strain behavior between these descriptions is considered borderline. It should be noted that shear strain in an undrained triaxial test is 1.5 times axial strain. Peak strength refers to peak principal stress difference ($\sigma_1 - \sigma_3$).

For the analyses in this chapter, it is generally more conservative to assume that a borderline material is sand-like than to assume it is clay-like. It is very difficult to obtain or prepare samples of in-situ low plasticity material for strength testing at its in-situ void ratio. Therefore, Atterberg-limits tests, gradation tests, and, preferably, CPT data should be used first as an index of stress-strain behavior to categorize materials as sand-like or clay-like. Laboratory stress-strain testing should be used to help categorize borderline materials.

The following criteria are recommended:

- Atterberg limits and gradation – Material should be treated as sand-like if the plasticity index of the material (measured from the portion passing the No. 40 sieve) is 7 or less.

Material should be considered clay-like if all of the following criteria are met:

- The material has 35 percent or more by dry weight passing the No. 40 sieve.
- The material has 20 percent or more by dry weight passing the No. 200 sieve.
- The plasticity index of the material (as measured by the portion passing the No. 40 sieve) is 10 or higher.

Material that does not fit either set of criteria should be treated as sand-like unless optional laboratory stress-strain testing demonstrates otherwise.

Commentary: In general, it is more conservative to treat a material as sand-like rather than as clay-like. The gradation and Atterberg-limit criteria provided above were selected as reasonably conservative recommended guidance by the authors of this chapter. These Atterberg-limit and gradation criteria may include as sand-like some materials that are considered clay-like by some investigators (e.g., Boulanger and Idriss (2004) who suggested a break between sand-like and clay-like behavior at a PI of 7). Seed et al. (2003) point out that there is no general agreement on Atterberg-limit criteria, and suggest a PI of 12 as one guideline for evaluating soil behavior, but they do not specifically refer to clay-like versus sand-like behavior.

- Cone penetration test data – CPT data can be used in conjunction with Atterberg-limit and gradation data to differentiate sand-like from clay-like material. CPT Soil Behavior Type Index I_c values below 2.6 should be considered sand-like (Robertson and Wride, 1998; Youd et al., 2001). I_c values above 2.6 may be considered clay-like. Material with I_c values above 2.6, but with very low values of friction ratio, should be considered clay-like but potentially highly sensitive (Section 7.4.4.2). If CPT data conflict with Atterberg limits and gradation data, the Atterberg limits and gradation data should generally govern. CPT data may also be used as an index to compare zones where Atterberg limits and gradation were measured with zones where Atterberg limits and gradation were not measured.

Commentary: Soil Behavior Type is based on where CPT data fall on a log-log plot of normalized CPT tip resistance versus friction ratio. Olsen and Mitchell (1995), reproduced in Seed et al. (2003), suggested a similar soil characterization framework based on the same type of plot.

- Laboratory test data – As mentioned previously, borderline materials (PI between 7 and 10 or otherwise not clearly sand-like or clay-like) should be classified as sand-like unless laboratory testing demonstrates otherwise. Laboratory testing for this purpose is optional. If performed, the testing should consist of isotropically-consolidated, strain-controlled, undrained triaxial compression tests with pore-pressure measurement performed on undisturbed samples. For the purpose of this testing, undisturbed sampling as described in Section 6.4.3.5 is recommended, considering also the discussion in Section 7.3 regarding sample quality. For this testing, the material has a PI of 7 or higher and is therefore less likely to densify during sampling than a less plastic sand-like material would be. Therefore, the detailed measurements of densification discussed in Appendices 7B and 7C for sand-like materials are not necessary for this sampling and testing. A consolidation stress of two-thirds of the in-situ vertical effective stress should be used to model in-situ conditions. If the axial strain at peak strength (peak principal stress difference, $\sigma_1 - \sigma_3$) is less than or equal to 3.33 percent (5 percent shear strain), then the material should be considered sand-like. If the axial strain at peak strength is more than 3.33 percent (5 percent shear strain) then the material should be considered clay-like.
- Highly sensitive clay-like and borderline materials – In very rare occurrences, natural soils and (non-coal) mine tailings have been identified that have a Liquidity Index greater than 1 (i.e., a natural water content greater than their Liquid Limit), a very high sensitivity (i.e., significant and abrupt strength loss), and low shear strain at peak strength. If materials such as this are encountered, special evaluations outside the scope of this manual may be appropriate. As a conservative approach, these materials may be assigned a post-earthquake strength of 20 psf (Table 7.1).

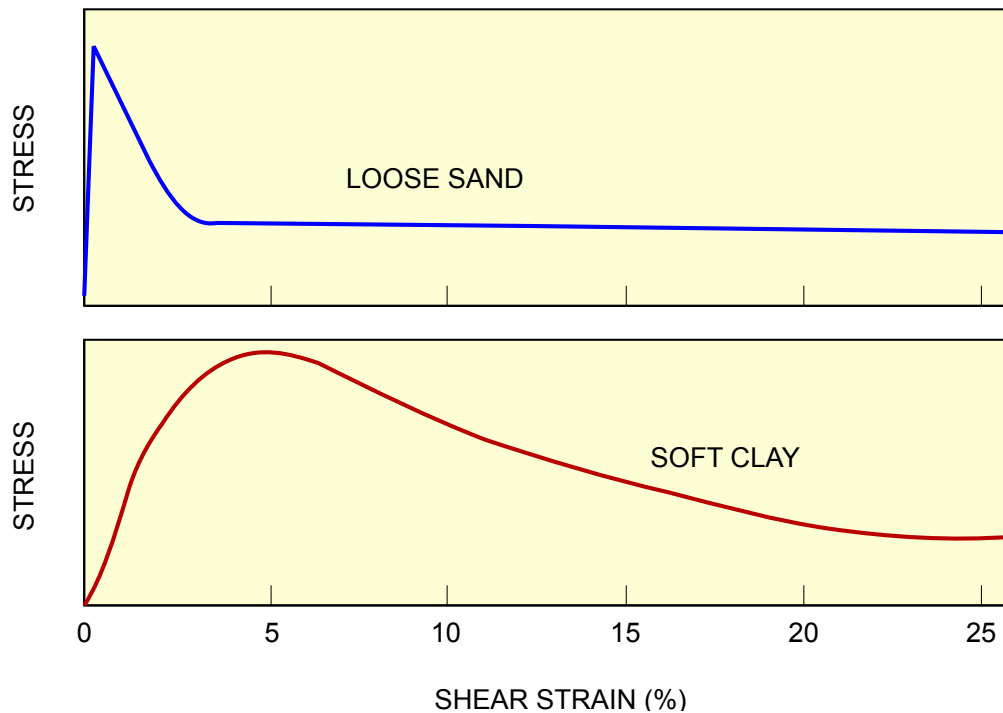

FIGURE 7.2 TYPICAL UNDRAINED STRESS-STRAIN CURVE

Loose zones of coarse refuse (e.g., zones of uncontrolled placement and compaction) should be treated as sand-like for the analyses discussed in this chapter. Combined refuse and intermixed zones of coarse and fine refuse should first be differentiated as predominantly coarse or fine refuse based on grain size and whether the coarse or fine refuse will control the response to loading. If the combined or mixed refuse is considered to be predominantly fine material, it should then be classified as sand-like or clay-like for the analyses in this chapter.

Soils, rock fill, and mixtures of soil and rock fill that are not coal refuse, whether part of a natural deposit, mine spoil, or other fill, will be referred to as natural soils. Natural soils can be described as coarse, sand-like, or clay-like, using the same general criteria as for refuse.

As discussed in [Section 6.2.3.2](#), fine coal refuse is often classified as a slightly plastic sandy silt or clay, or a slightly plastic to non-plastic silty sand. The Plasticity Index varies from non-plastic ($PI = 0$) to $PI > 10$. In other words, fine coal refuse may be sand-like, clay-like, or borderline. Fine coal refuse (and some natural soils) may be highly stratified in very thin layers. CPT data are often useful in delineating this stratification. The designer must make a judgment as to whether clay-like or sand-like layers will control the behavior of individual zones. In general, zones consisting of stratified layers of sand-like and clay-like material should be considered sand-like, unless detailed field or laboratory data indicate otherwise.

7.1.4 Susceptibility to Strength Loss

As discussed in [Section 7.4.4.2](#), saturated or nearly-saturated, loose, sand-like material with $N_{1,60}$ values less than 15 or q_{t1} values less than 75 tsf (as defined in [Section 7.2](#)) is considered potentially contractive (potentially susceptible to strength loss). As also discussed in [Section 7.4.4.2](#), clay-like material with CPT values of tip resistance and side friction falling in certain ranges or with SPT N-values less than 6 (corrected for hammer efficiency per Youd et al. (2001), but not corrected for overburden pressure) is considered potentially susceptible to strength loss. These criteria are used to determine whether various zones within the embankment require further evaluation.

7.1.5 Simplified Steps for Seismic Stability

While a variety of methods for exploration, testing, and analysis are described in this chapter, simplified steps that provide a direct path for evaluating seismic stability are available. As introduced in [Section 7.1.2](#), the recommended sequence of analysis is described in the flow charts in [Figures 7.1a, 7.1b](#) and [7.1c](#), which allow the option of either skipping or incorporating sophisticated methods.

The intent of this section is to describe simplified steps for estimating soil and refuse properties for a relatively straightforward analysis without the need for extensive testing and analysis that will lead to safe designs based on supportable conservative assumptions and correlations. However, for existing structures there may be no simplified methodology for characterizing the existing conditions (i.e., finding out what types of soils are present and where). The simplified analyses and estimates of engineering soil properties are necessarily conservative, and in some cases a more detailed analysis may show them to be very conservative. Optional steps, which require additional testing and analysis to more accurately measure or predict material behavior and thereby reduce the conservatism in these simplified steps, can be considered and are discussed in other sections of this chapter.

The following basic steps describe a relatively straightforward sequence that can be followed for design or evaluation of a new or existing high-hazard-potential slurry impoundment dam (or other dam). (Box numbers refer to the flow charts in [Figures 7.1a, 7.1b](#) and [7.1c](#).) The steps described in the following text do not require sophisticated laboratory testing or relatively complex triggering analyses. A site-specific seismicity evaluation is only required for deformation analyses (not for seismic stability analyses) and may not be needed if the site is in a low-seismic-hazard area ([Section 7.7.3.7](#)).

7.1.5.1 Step 1

For a high-hazard-potential dam, proceed from Box 3 to Boxes 7 and 7A. Define the geometry of the dam and identify zones of clay-like and sand-like material (per [Section 7.1.3](#)). For an existing dam, the geometry will be based on construction records, a site survey, the results of borings and in-situ testing (preferably CPTs), and laboratory index testing (grain size and Atterberg limits). For design of a new dam, the foundation materials and properties will be based on exploration and testing programs, and embankment geometry will be based on the development plan and anticipated construction procedures and refuse properties.

7.1.5.2 Step 2

Characterize the fine refuse to address stratification, layering, distinction of sand-like and clay-like materials, and estimation of strength and associated properties. As discussed in [Section 7.3](#), Cone Penetration Testing (CPT) in combination with recovery of samples (using SPTs, for example) is recommended for addressing these issues.

7.1.5.3 Step 3

Characterize the fine refuse deposits (and other materials) as either clay-like or sand-like, per the criteria given in [Section 7.1.3](#), based on laboratory grain-size and Atterberg-limits tests.

7.1.5.4 Step 4

Screen the various zones in the dam for susceptibility to strength loss based on the SPT and (preferably) CPT data. Basically (as detailed in [Section 7.4.4.2.1](#)), sand-like material with $N_{1,60}$ values less than 15 or q_{t1} values less than 75 is considered potentially susceptible to strength loss. Clay-like material with N values less than 6 or CPT data in certain ranges is also considered potentially susceptible to strength loss. Screening to determine the susceptibility to strength loss should consider both CPT and SPT data when available. If such testing produces inconsistent results, it should be resolved in favor of the more reliable and robust data set considering the amount, consistency and quality of the

data. For design of a proposed dam, zones potentially susceptible to strength loss should be defined based on experience, available data from nearby sites, and published data for similar facilities. For slurry impoundments, consider similarities in coal seams, mining and processing methods, and fine refuse deposition.

7.1.5.5 Step 5

Perform a limit-equilibrium stability analysis using conservative post-earthquake strengths (as detailed in [Section 7.4.4.3](#)). For zones that are screened as not being potentially susceptible to strength loss, the post-earthquake strengths are the same as those used in the static stability analysis.

For sand-like material considered susceptible to strength loss, the appropriate strength is the undrained shear strength at very high strain (undrained steady-state strength S_{us}), which can be obtained from correlations with SPT and/or CPT data ([Section 7.4.3.1](#)). Even more simply, as a lower bound, S_{us} for sand-like material can be taken as $0.04 \sigma'_v$ (if the material is non-plastic or has a liquidity index of less than 1), as discussed in [Section 7.4.3.1](#) and as shown in [Table 7.1](#). For design of a new dam, S_{us} can be taken as $0.04 \sigma'_v$, or higher values may be used based on supporting data for similar materials for existing dams.

For clay-like material considered susceptible to strength loss (e.g., highly sensitive clay-like material), the appropriate post-earthquake strength is also S_{us} , which can be obtained from field vane-shear tests or from CPT data (as described in [Section 7.4.3.3](#)). A lower-bound, post-earthquake strength for clay-like material can be taken as $0.04 \sigma'_v$ (if the material has a liquidity index less than 1), as discussed in [Section 7.4.3.3](#) and as shown in [Table 7.1](#). For design of a new dam, S_{us} can be taken as $0.04 \sigma'_v$, or higher values may be used based on supporting data for similar materials at existing dams.

Commentary: The lower-bound, post-earthquake strength of $0.04 \sigma'_v$ is considered conservative for either sand-like or clay-like fine coal refuse. As more testing and analysis of fine refuse becomes available, refinements to the 0.04 relationship can be expected (initial published work is discussed in [Section 7.4.3.2.3](#)). For proposed dams, strengths estimated during design must be validated during construction by performing field investigations and obtaining samples of the actual materials.

For clay-like material that is not considered susceptible to strength loss, the appropriate post-earthquake strength is typically much higher than S_{us} . Guidance for characterizing the post-earthquake undrained shear strength of such clay-like material, based primarily on consistency and strain and/or cyclic stress level considerations, is provided in later sections.

If the safety factor for the stability analysis using post-earthquake strengths is greater than or equal to 1.2, continue by performing a deformation analysis (from Box 8 go to Box D1). If the safety factor is less than 1.2, redesign the dam (skip from Box 8 to Box 17) to reduce the influence of material zones susceptible to strength loss. Alternatively, if the safety factor is less than 1.2, consider performing more detailed evaluations of triggering and post earthquake strength, as described in [Sections 7.4.3](#) and [7.4.4](#).

7.1.5.6 Step 6

There are several methods of deformation analysis that can be used, depending on the site seismicity and the presence of material susceptible to strength loss. If the dam is in an area of low seismic hazard and is not influenced by materials that are potentially susceptible to strength loss, then a relatively simple pseudo-static procedure can be used (as described in [Section 7.5.3](#)). Otherwise, more complex analyses are required ([Section 7.5](#) and portion of flow chart in [Figure 7.1c](#)), and the computed deformations must be compared to recommended tolerable values.

TABLE 7.1 COMPARISON OF BASIC CRITERIA FOR SAND-LIKE, CLAY-LIKE AND BORDERLINE MATERIALS

	Sand-Like	Clay-Like	Borderline (Treat as Sand-Like)	Borderline (Treat as Clay-Like)
Atterberg limits	$PI \leq 7$	$PI \geq 10$	$7 < PI < 10$	$7 < PI < 10$
% passing No. 40 sieve		≥ 35		≥ 35
% passing No. 200 sieve		≥ 20		≥ 20
Triaxial tests on undisturbed samples to obtain stress-strain curve	Not Required	Not Required	Not Required	Shear strain at peak strength must exceed 5%; otherwise treat as sand-like
Lower-bound post-earthquake strength	0.04 σ'_v if non-plastic, or if LI is < 1.0	0.04 σ'_v if LI is < 1.0	0.04 σ'_v if LI is < 1.0	0.04 σ'_v if LI is < 1.0
	20 psf if $LI \geq 1.0$, but no higher than 0.04 σ'_v	20 psf if $LI \geq 1.0$, but no higher than 0.04 σ'_v	20 psf if $LI \geq 1.0$, but no higher than 0.04 σ'_v	20 psf if $LI \geq 1.0$, but no higher than 0.04 σ'_v
Other methods to obtain post-earthquake strength	1. Correlations with SPT/CPT 2. Steady-state lab testing	1. Field vane shear or CPT 2. Cyclic followed by static lab testing	Correlations with SPT/CPT	1. Field vane shear or CPT 2. Cyclic followed by static lab testing
Field vane-shear testing for peak-undrained strength and S_{us}	Not Applicable	Applicable	Potentially Applicable if it can be demonstrated that the test is undrained (Section 6.4.3.8)	Potentially Applicable if it can be demonstrated that the test is undrained (Section 6.4.3.8)
CPT to help identify layering and to differentiate sand-like from clay-like	Recommended	Recommended	Recommended	Recommended
CPT to measure peak undrained strength and S_{us}	Not Applicable	Applicable	Potentially Applicable if it can be demonstrated that the test is undrained (Section 6.4.3.7)	Potentially Applicable if it can be demonstrated that the test is undrained (Section 6.4.3.7)

Note: 1. PI is the Plasticity Index.
2. LI is the Liquidity Index.

7.2 TERMINOLOGY

The terms defined in the following list are specifically related to seismic stability and deformation analyses. These definitions should be reviewed carefully because in the literature authors may assign various meanings to the same terms. Basic terminology related to subsurface investigations, material strength, and static stability analysis is discussed in Chapter 6.

Clay-like material – This term is defined in [Section 7.1.3](#).

Contractive soil or refuse – Contractive materials compress when sheared under drained conditions. They generate positive excess pore pressures when sheared under undrained conditions. Thus the undrained strengths are lower than the drained strengths. Loose sand-like material tends to be contractive. When sheared undrained, the peak strength is typically reached at relatively low strain, and strength can decrease (i.e. strain-soften) significantly at higher strains. Soft clay-like material also tends to be contractive. However, when sheared undrained, the peak strength develops at relatively high strains and the strength decreases gradually at strains beyond the strain at peak strength.

Cyclic mobility – Cyclic mobility is the progressive softening and resulting large cyclic strains that occur in saturated soils during undrained cyclic loading in which shear stress

reversal occurs (Casagrande, 1971; Castro, 1975). In an undrained cyclic-triaxial test, stress reversal occurs during cyclic loading if the sample is loaded in extension as well as compression. In the field, stress reversal occurs when the cyclic shear stresses induced by the earthquake exceed the static shear stresses. When this occurs, the stress strain curve after some number of cycles develops an S-shape, and significant cyclic strains are generated. The condition of significant cyclic straining is defined as “cyclic mobility.” Robertson (1994) and Robertson and Wride (1998) suggested the term “cyclic liquefaction” to describe this phenomenon and suggested that the term “cyclic mobility” be used to describe the cyclic strain behavior of anisotropically consolidated soil subject to undrained cyclic loading without stress reversal. For the latter case, cyclic strains are smaller. However, the original definition of cyclic mobility will be used in this Manual.

Cyclic resistance ratio (CRR) – Used in the pore-pressure-based method of triggering analysis for sand-like material (Section 7.4.2.2). CRR is a measure of the resistance of a material to pore-pressure increase caused by earthquake shaking.

Cyclic stress ratio (CSR) – Used in the pore-pressure-based method of triggering analysis for sand-like material (Section 7.4.2.2). CSR is a measure of the shear stress generated by the earthquake shaking.

Dilative soil or refuse – Dilative materials expand at large strains when sheared under drained conditions, and they generate negative excess pore pressures when sheared under undrained conditions. Thus the undrained strengths can be higher than the drained strengths. The amount by which the undrained strength exceeds the drained strength is limited by possible cavitation of the pore water. However, it is customary to neglect strengths higher than the drained strength. Medium-dense and dense sand-like materials tend to be dilative at large strains. When sheared undrained, the strength nearly reaches its peak at moderate strain and then levels off or increases (i.e. strain-hardens) gradually at higher strains.

Commentary: During undrained monotonic (non-cyclic) loading, dilative soils normally generate small positive excess pore pressures at small strains, and then generate negative excess pore pressures at higher strains. During undrained cyclic loading, dilative soils can experience pore-pressure buildup. Depending on the cyclic strain, both positive and negative excess pore pressures can develop at different portions of the load cycle. But after each full load cycle there will normally be an increase in positive excess pore pressure. However, if loaded statically after cyclic loading, the soil tends to dilate as strains increase, the positive excess pore pressures diminish, the excess pore pressure becomes negative, and the soil strain-hardens. In other words, even though dilative material can develop positive excess pore pressures during cyclic loading, dilative material will not lose strength as a result of the cyclic loading.

Flow slide – If saturated material in an embankment or its foundation experiences strength loss, and the static (gravity) shear stresses (often referred to as the driving stresses) exceed the available shear strength, then the embankment can experience instability and failure (depending on the amount of material that experiences strength loss and the geometry of the structure). The failure is often referred to as a flow slide in cases where the material controlling the instability experiences an abrupt loss in strength such that: (1) it approaches the steady-state (residual) strength, (2) the slide mass appears to deform almost like a liquid, and (3) deformations propagate over a substantial zone, rather than along a well-defined failure surface. In such cases, the failure mass can slide a long distance before coming to rest. Although movements might commence along a well-defined failure surface, a substantial portion of the slide mass may experience strength loss as slope movements develop, and a flow slide can evolve. With sand-like materials, instability can be rapid and can occur with little warning, and deformations can be very large.

Liquefaction – The term “liquefaction” has been used in the literature to describe several related but distinctly different phenomena. These phenomena include: (1) flow slide failures of embankments and dams, (2) lateral spreading of gently sloping ground, (3) development of 100 percent excess pore pressure during undrained cyclic loading often accompanied by the appearance of sand boils at the ground surface, and (4) the development of high shear strains and/or high excess pore pressures in cyclic laboratory tests. In this Manual, the term “liquefaction” is not used. Instead, more descriptive and precise terminology is used.

Commentary: The following terms are sometimes used in the literature, but are not used in this Manual. They are presented here for completeness.

Initial liquefaction – During cyclic loading, initial liquefaction is the first occurrence of momentary zero effective stress (pore pressure = 100 percent).

Cyclic failure – Term sometimes used (Boulanger and Idriss, 2004) to describe the onset of high excess pore pressures and large shear strains during undrained cyclic loading of clay-like soils. In Boulanger and Idriss’s usage, “cyclic failure” of clay-like materials is comparable to “liquefaction” of sand-like materials.

Cyclic liquefaction – Term suggested by Robertson (Robertson, 1994; Robertson and Wride, 1998) to describe the progressive softening and resulting large cyclic strains that occur in saturated sands during undrained cyclic loading where shear stress reversal occurs. Synonymous with the definition of “cyclic mobility” used by Casagrande and others in the 1970s.

Flow liquefaction – Term sometimes used (Robertson and Wride, 1998) for “flow slide.”

Liquidity Index (LI) – The Liquidity Index is derived from the Atterberg limits. $LI = (\text{water content} - PL)/(LL - PL)$. If $LI = 1$, the natural water content equals the liquid limit.

N – The Standard Penetration Test (SPT) *N*-value, uncorrected.

$N_{1,60}$ – The SPT *N*-value, normalized to an effective overburden stress of one tsf (approximately one atmosphere) and normalized to a hammer efficiency of 60 percent (Youd et al., 2001).

Peak Ground Acceleration (PGA) – The maximum horizontal ground surface acceleration at a site caused by the design earthquake. Values of PGA obtained from seismic hazard assessments normally refer to accelerations measured at bedrock outcrops or at the ground surface of stiff soil profiles. These values of PGA are usually not directly applicable to the ground surface of sites with other types of soil profiles. Also, the PGA (maximum horizontal ground surface acceleration) at the top of an embankment will generally be different from the PGA at the ground surface at the base of the embankment. PGAs obtained from seismic hazard assessments are usually not directly applicable to the top of an embankment. A site response analysis can be used to estimate the PGA at the top of an embankment based on the PGA identified for a bedrock outcrop or stiff soil profile.

Post-earthquake shear strength – The shear strength available at the end of an earthquake, used in a static, limit-equilibrium stability analysis to evaluate post-earthquake stability. For each zone of coal refuse or natural soil, the strength used in the analysis is estimated based on the expected response of the material to earthquake shaking. The strength used could be the peak drained strength, the drained steady-state (residual) strength, the peak undrained strength, the undrained steady-state (residual) strength, or other intermediate strength.

q_c – Measured Cone Penetration Test (CPT) tip resistance.

q_t – Measured CPT tip resistance corrected for unequal end-area pore-pressure effects (Lunne et al., 1997). For CPT in clean to silty sands, q_c and q_t are essentially the same and are often used interchangeably.

q_{t1} – CPT tip resistance (q_t) normalized to an effective overburden stress of one atmosphere (typically 1 tsf), in units of stress: $q_{t1} = 1.8 q_t / (0.8 + \sigma'_v / P_a)$. (Olson and Stark, 2002)

q_{t1N} – Dimensionless CPT tip resistance, i.e., q_{t1} normalized by a reference pressure of one atmosphere and expressed in dimensionless terms. Sometimes referred to as Q or Q_t .

For clay-like material: $q_{t1N} = (q_t - \sigma_{v0}) / \sigma'_{v0}$

For sand-like material, refer to Youd et al. (2001)

$(q_{t1N})_{CS}$ – q_{t1N} corrected to an equivalent value for clean sand (Youd et al., 2001).

Sand-like material – This term is defined in [Section 7.1.3](#).

Sensitivity – Sensitivity in clays is normally defined as undisturbed strength divided by remolded strength (S_{up}/S_{us}). In this chapter, the term “highly sensitive” is used to refer to clays that have undrained stress-strain behavior similar to loose sands. Highly sensitive clays have a relatively small strain at peak undrained strength and a significant drop-off in shearing resistance (strain-softening) after the strain at peak. One example of highly sensitive clay is Norwegian quick clay. Clay-like coal refuse is generally not highly sensitive.

S_{dp} , S_{ds} , S_{up} , and S_{us} – Drained peak strength, drained steady-state (residual) strength, undrained peak strength, and undrained steady-state (residual) strength. In this Manual, these strengths are defined as being measured under monotonic loading unless noted otherwise. See also the definition of “undrained steady-state strength.”

Strength loss – The tendency for contractive soils to have lower undrained strength at high strains than at lower strains ($S_{us} < S_{up}$). The term strength loss is used to indicate a reduction in available strength from S_{up} to a lower value, not a complete loss to zero strength. If earthquake shaking causes shear strains and pore pressures to increase in a soil, the soil may experience strength loss (in the extreme, a reduction from S_{up} to S_{us}). Loose sand-like soil may experience a reduction in strength to S_{us} as the result of relatively small earthquake shaking because the strain at peak strength is relatively low. Clay-like materials (excluding highly sensitive clay soils) tend to experience less abrupt loss of strength because they reach both peak undrained strength and S_{us} at much higher strains than sand-like materials.

Commentary: In many cases the available strength before a failure has been the drained strength throughout the history of the facility, because all loads have been applied sufficiently slowly to allow drainage. During an earthquake (or other disturbance such as a relatively quick loading of additional fill or a relatively quick cut near the toe of an embankment), shear stresses are applied quickly enough that the soil behaves in an undrained manner. In contractive soils the peak undrained strength would be lower than the previously available drained strength, and thus shear deformations or failure might ensue. In these cases, strength loss has sometimes been defined as a reduction in available strength from S_{dp} to S_{up} (and then possibly to S_{us}).

For the purposes of this chapter, references to strength loss do not include reductions from S_{dp} to S_{up} . In this chapter, strength loss only refers to a decrease in available strength from S_{up} to (or toward) S_{us} . As discussed in [Section 6.6.4.2.1](#), this Manual includes analysis of the potential for strength reduction from S_{dp} to S_{up} as part of static stability analyses, with undrained peak strength (possibly reduced to account for potential progressive failure) used in zones of fine refuse.

A rise in groundwater level (or rise in the phreatic surface) can reduce stability in several ways, including the following:

- A rise in groundwater level can result in a decrease in effective stress in what was previously an unsaturated zone. This decrease in effective stress may result in a decrease

in available drained strength within that zone. This by itself is not likely to cause a failure, because the saturated drained strength is normally adequate to maintain stability.

- *In some cases of very loose materials in a previously unsaturated zone, a rise in groundwater level can trigger collapse of the material matrix. This results in a rapid rise in pore pressure and a decrease in available strength within that zone from drained to undrained. Since the material is very loose, the undrained strength can be substantially lower than the drained strength, and a failure could ensue if the zone of affected material is large enough. This is unlikely to be a concern for fine coal refuse that is deposited through water and consolidates while saturated.*
- *A rapid rise in reservoir level could cause a rapid increase in seepage forces and thus driving stresses such that the soil within the embankment behaves as undrained rather than drained. (In contractive materials, the available strength would decrease from S_{dp} to S_{up} , as discussed in the first paragraph of this commentary.)*

The term strength loss has been used to describe these phenomena related to groundwater. However, in this chapter, the term strength loss only refers to a reduction from S_{up} to (or toward) S_{us} .

Triggering – Term used to indicate that earthquake shaking is strong enough to cause, or trigger, strength loss. Some engineers propose that triggering of strength loss occurs when excess pore pressures due to cyclic loading reach 100 percent (effective stress reaches zero). Some engineers propose that triggering of strength loss occurs when a certain level of shear strain is reached, whether or not pore pressures have reached 100 percent. And some engineers propose that triggering of strength loss occurs when shear stresses exceed a certain level. The various approaches are discussed in this Manual. Triggering might also be caused by loadings other than earthquake loadings, such as rapid increases in embankment height, excavation of toe materials due to re-mining of coal refuse in an impoundment, or rapid changes in groundwater level.

Undrained residual strength – Term often used in the literature to describe the undrained soil or coal refuse shear strength at very high strains. It is synonymous with “undrained steady-state strength.” The term “residual strength” is often used in the literature to refer to drained as well as undrained strength. In this chapter, residual strength normally refers to undrained steady state (residual) strength.

Undrained steady-state strength – The undrained steady-state shear strength is the undrained shear strength of soil or coal refuse at very high strains (Poulos, 1981). This is the minimum shear strength of the material at a given void ratio. It is synonymous with terms such as “undrained residual strength,” “critical state strength,” “ultimate undrained strength,” “minimum undrained strength” and “liquefied undrained strength.” This Manual will use the term “undrained steady-state (residual) strength” or S_{us} .

7.3 CHARACTERIZATION OF SUBSURFACE CONDITIONS AND MATERIAL PROPERTIES

Previous chapters in this Manual have discussed the field exploration programs and laboratory testing needed for characterizing subsurface conditions and material properties for analysis and design. This section discusses issues related specifically to seismic analysis. These issues include:

- **Field testing and sampling quality** – Special attention to the details of field sampling and testing is required for the procedures and analyses discussed in this chapter. Drillers and other field exploration contractors should be selected and engaged based on contract terms that encourage quality over speed. Proper use of casing, drilling mud, and upward deflecting drill bits and properly maintaining a fluid head on the

borehole are important in SPT sampling, vane-shear testing, and obtaining undisturbed tube samples.

- Field vane-shear testing – Field vane-shear tests can be used to measure the undrained peak strength and undrained steady-state (residual) strength of clay-like material (Sections 6.4.3.8 and 7.4.3.3). Field vane shear tests should not be used to measure the undrained strength of sand-like material because sand-like material will drain during the course of the test, and the measured strength may be very unconservative (Table 7.1). Details of testing procedures (which differ in some important respects from the ASTM procedures) and criteria for confirming that the material remains undrained during the test are discussed in Section 6.4.3.8.
- CPT and SPT – Both cone penetration tests and standard penetration tests are recommended for characterizing fine coal refuse. CPT data are generally more repeatable and less affected by equipment or operator variability. CPTs are generally faster and less expensive than SPTs for each exploration location, and CPTs provide continuous data. SPTs provide physical samples for visual classification and for index testing. CPTs are often used for initial site characterization. A more comprehensive site exploration program (including more CPTs, at least some SPTs, and other methods) can then be developed based on the results of the initial CPTs. When using the CPT, samples must also be obtained to verify soil type (by visual classification and index testing). Samples can be obtained using CPT push equipment, using SPTs, or by other methods. SPTs should be performed in general accordance with ASTM D 6066, which includes special provisions for seismic analyses in addition to the basic SPT procedures contained in ASTM D 1586. For high-hazard-potential dams, the hammer energy should be verified, and a qualified engineer or geologist should be assigned on a full-time basis to each drill rig to observe the testing procedures and to log the borings.

Fine refuse should be sufficiently characterized in the field to determine stratification, layering, distinction of sand-like and clay-like materials, and estimation of strength and associated properties. CPTs, in combination with recovery of samples (e.g., SPT samples), are recommended for addressing these issues at impoundment sites. Using both the SPT and CPT provides an opportunity for collecting redundant and complementary data to define layers and associated strengths of soft or loose deposits with a degree of resolution generally not achievable by relying solely on SPTs. However, there may be sites that, because of the fine refuse characteristics (e.g., uniformity of deposit, penetration resistance, etc.) or available detailed records of dam design and construction, can be adequately characterized by the SPT alone.

- Index testing – Whenever engineering property testing is performed, index testing (grain-size, Atterberg-limits, and specific-gravity) should be performed to allow comparison and interpretation of test results on different samples and to improve the understanding of the relationship between index properties and engineering properties of coal refuse. Grain-size analyses, hydrometer analyses, Atterberg-limits tests, and other index tests should be performed on samples that have not been air-dried or oven-dried. Wet preparation methods should be used.
- Undisturbed sampling – Obtaining high quality, undisturbed samples of sand-like material requires specialized procedures. Thin-walled, fixed-piston tube samplers, both mechanically actuated and hydraulically actuated, have been used successfully. A detailed procedure for using fixed-piston samplers is provided in Appendix 7C. Freezing of sandy material for either sampling or transportation has also been used. Freezing must be performed in a manner that allows the liquid water to escape the

sample as the freezing front advances. If liquid water becomes trapped, it will expand as it freezes and cause loosening of the sample.

- **Representative sampling** – Samples for laboratory testing must be representative of the layer being investigated. Therefore sufficient CPT and/or SPT data must be obtained to delineate material zones. Unsuccessful attempts to obtain undisturbed tube samples should be documented in order to confirm that the loosest material is being taken into account in the evaluation.
- **Variability and layering** – Variability is best evaluated based on CPT data and depositional history. Estimation of the depositional history includes consideration of all available information, including observations of the surface and documented or anecdotal information on operation of the structure. Undisturbed sampling and testing is not the best way to study variability and is most effectively performed after the variability of the deposit has been characterized.
- **Material zones** – Many of the analyses discussed in this chapter refer to zones of material. Zones should be identified based on consideration of depositional environment, grain size, plasticity, and penetration resistance (density and strength). Loose material should not be combined with medium or dense material in a single zone. CPT is often the most efficient method for defining the extent of loose zones. Further guidelines for site characterization are provided in Chapter 6.
- **Piezometric levels and degree of consolidation** – Soil properties are often estimated as a function of effective consolidation stress. Materials within tailings impoundments are not always fully consolidated under the current conditions of fill height and groundwater level. Therefore, to confirm estimates of effective consolidation stresses, subsurface exploration programs should include installation of piezometers for measurement of piezometric levels within various material zones at various depths within the impoundment. The piezocone is also valuable for measuring piezometric levels.
- **Laboratory testing on reconstituted samples** – Obtaining high-quality, undisturbed samples is often difficult, especially for materials with low plasticity. It would be easier to measure the steady-state strength of sand-like materials by reconstituting samples in the laboratory, starting at a very loose condition and consolidating them to the in-situ confining pressures. Unfortunately, there is little or no literature to document that reconstituted samples of fine coal refuse have the same void ratios or strengths as undisturbed samples with the same confining pressures. Anecdotal evidence for some natural soils and other mine tailings indicate that in some cases the reconstituted samples have significantly lower void ratios (and therefore higher steady state strengths) than undisturbed specimens at the same confining pressures, apparently either because of time effects (the time over which confining pressures are applied) or fabric effects (the particle structure is different in the lab and field). As a result, testing of reconstituted samples is generally not recommended without some verification that the consolidated laboratory samples have void ratios similar to the in-situ material. This might be a fruitful area for future research.

Commentary: For sand-like materials, use of reconstituted samples is recommended for developing the slope of the steady-state line in [Section 7.4.3.2.3](#) and for laboratory testing associated with the strain-based method of triggering analysis in [Section 7.4.2.3.1](#). However, these are exceptions to the general rule for using undisturbed samples. In the first case, in-situ strength is not being measured directly with the remolded samples; the slope of the steady state line is being measured. To obtain the in-situ, steady-state strength, undisturbed samples are needed. In the second case, samples are remolded and consolidated to match the in-situ void ratio (not

the in-situ confining pressure), and undisturbed samples are also needed for measurement of the in-situ void ratio.

- **Material Properties for Proposed Structures** – For design of a new dam, material properties may be based on supporting data for similar materials for existing facilities. Zones potentially susceptible to strength loss should be defined based on experience, available data from nearby sites, and published data for similar facilities. For slurry impoundments, consideration should be given to similarities in coal seams, mining and processing methods, and fine refuse deposition. The lower bound post-earthquake strength of $0.04 \sigma'_v$ is considered conservative for either loose sand-like or soft clay-like fine coal refuse, assuming the liquidity index is less than one (Table 7.1). As more testing and analysis of fine refuse becomes available, refinements to the $0.04 \sigma'_v$ relationship can be expected (initial published work is discussed in Section 7.4.3.2.3). Strengths estimated during design must be validated during construction by performing field investigations and obtaining samples of the actual materials. These data may lead to the need to modify the design of the facility.

7.4 SEISMIC STABILITY ANALYSES

7.4.1 General Discussion

Seismic instability may occur when the overall average post-earthquake shear strength is less than pre-earthquake shear strength in one or more zones of an embankment. The driving force of the stability failure is the static (gravity) weight of the embankment. For seismic instability to occur, three conditions must be met:

1. The earthquake shaking must be strong enough to trigger undrained strength loss in one or more zones of material.
2. The post-earthquake strengths must be less than the static driving shear stresses.
3. The amount of material that experiences strength loss must be sufficient to cause instability.

There are three general components to a seismic stability analysis:

1. Evaluation of whether the earthquake is strong enough to cause strength loss in one or more zones of the embankment or foundation. This is referred to as a triggering analysis.
2. Evaluation of the post-earthquake strengths in the various soil zones that may be susceptible to strength loss.
3. Performance of static, limit-equilibrium, slope-stability analyses using post-earthquake strengths for the materials in the embankment and foundation.

7.4.1.1 Triggering Analyses

In saturated, sand-like material, a small shear strain (1 percent or less) can trigger sudden strength decrease from S_{up} to S_{us} . In clay-like material, high shear strain (5 percent or more) is generally needed to cause some strength loss, and very high shear strain is generally needed to cause strength loss all the way to S_{us} . Highly sensitive clays may behave similarly to sand-like material in that strength loss may occur at low shear strains. Three general approaches to triggering analysis are discussed in Section 7.4.2, and are summarized as follows:

- **Pore-pressure-based approach** (Sections 7.4.2.1 and 7.4.2.2) – Uses a method developed for evaluating whether earthquake shaking will generate high excess pore

pressures as an index of whether the earthquake shaking will trigger strength loss in sand-like materials. This approach is not applicable to clay-like materials.

- **Strain-based approach** – For clay-like material (Section 7.4.2.3.1), this approach considers post-earthquake strength as a function of shear strain that occurs during the earthquake. For sand-like material (Section 7.4.2.3.2), this approach assumes that strength loss is triggered when the cyclic shear strain induced by the earthquake exceeds a critical value (i.e., the triggering shear strain).
- **Stress-based approach** (Section 7.4.2.3.3) – This approach assumes that strength loss is triggered when shear stresses exceed the undrained yield strength (the peak undrained strength). This approach is not applicable to clay-like materials.

It is important to note that for loose, saturated, sand-like material, moderate to large earthquakes will almost always be large enough to trigger strength loss. Therefore, triggering analyses should not be used to confirm the adequacy of a dam or embankment if the PGA at the base of the embankment is higher than 0.2g and the CSR (Section 7.4.2.2.1) in the zone of loose sand-like material is greater than 0.15. If the design earthquake causes a higher site PGA, then triggering of strength loss should simply be assumed for zones of loose, sand-like material with $CSR > 0.15$. The post-earthquake strength of the material in the loose zone should be assumed to be equal to S_{us} . A PGA of 0.2g and CSR of 0.15 are recommended guidance. In evaluating potential measures to improve the stability of a dam or embankment where the CSR in a zone exceeds 0.15, it may be useful to perform a triggering analysis to help assess whether alternative stabilization schemes that would reduce the CSR might ultimately improve the dam or embankment stability.

7.4.1.2 Evaluation of Post-Earthquake Strength

If the earthquake shaking triggers strength loss, the post earthquake strength of sand-like material will be the undrained, steady-state strength S_{us} , which is primarily a function of void ratio and is very sensitive to small changes in void ratio. The void ratio of sand-like material is primarily a function of the method of deposition. Even within a seemingly uniform layer, sand-like material deposited by water (including both natural sands and fine coal refuse) has significant variability in void ratio. As a result, multiple samples of sand-like material from the same zone or layer are likely to have varying values of S_{us} . Therefore, methods of evaluating S_{us} of sand-like materials for stability analyses should account for the potential variability within zones or layers.

In contrast, the void ratio of clay-like material is primarily a function of consolidation pressure and stress history. Furthermore, the peak-undrained strength and the steady-state (residual) strength in clay-like material is less sensitive to void ratio than in sand-like material. As a result, post-earthquake strengths within a zone are likely to be more uniform for clay-like material than for sand-like material.

Three general approaches to evaluating the post-earthquake strengths of materials that may be susceptible to strength loss are discussed in Section 7.4.3. The three approaches are:

1. Empirical correlations of SPT and/or CPT values with back-figured, post-earthquake strengths from flow slides may be used to estimate S_{us} for sand-like material (Section 7.4.3.1). These methods assume that the earthquake shaking triggered strength loss, so the post-earthquake strength is S_{us} .
2. Laboratory tests on high-quality samples from the field can be used to estimate post-earthquake strengths for both clay-like and sand-like material (Section 7.4.3.2).
3. Field vane-shear tests and CPTs can be used to measure S_{us} for clay-like material (Section 7.4.3.3). As discussed in Section 7.4.2.3.1, S_{us} is often a conservative low estimate of the actual post-earthquake strength for clay-like material.

7.4.1.3 Stability Analysis Using Post-Earthquake Strengths

A generalized approach presented as a series of steps for performing the triggering analyses, the post-earthquake strength evaluations, and the limit equilibrium stability computations is provided in [Section 7.4.4](#).

7.4.2 Triggering Analyses

7.4.2.1 Pore-Pressure-Based Method for Triggering of Strength Loss in Clay-Like Material

There is general agreement that highly plastic clays (with the exception of highly sensitive clays) are not susceptible to either significant pore-pressure buildup or strength loss due to earthquake shaking (Seed et al., 2003).

For clays that are not highly plastic, several criteria for pore-pressure buildup and susceptibility to strength loss due to earthquake shaking, based on Atterberg limits and percent clay content, have been proposed (Seed et al., 2003). However, while there is general agreement that susceptibility to strength loss decreases with increasing plasticity and increasing SPT or CPT resistance, there is no general agreement on specific criteria at the time of publication of this Manual.

Screening-level evaluations of the susceptibility of clay-like materials to strength loss, based on CPT and SPT data, are discussed in [Section 7.4.4.2](#). More detailed estimates of whether earthquake shaking is strong enough to trigger strength loss in clay-like material can be obtained by using the strain-based methods discussed in [Sections 7.4.2.3.1](#) and [7.4.3.2.2](#).

7.4.2.2 Pore-Pressure-Based Method for Triggering of Strength Loss in Sand-Like Material

This method is used for evaluating whether the design earthquake is large enough to cause (trigger) strength loss. For loose/contractive sand-like material, the earthquake shaking required to trigger strength loss is normally small, and triggering causes strength loss all the way to S_{us} . Therefore, as discussed in [Section 7.4.1](#), if the design peak ground acceleration (PGA) at the embankment site is larger than 0.2g and the CSR within the zone of loose sand-like material is greater than 0.15, then the triggering analysis described in the following paragraphs should not be performed, and triggering of strength loss should simply be assumed. The post-earthquake strength of the material in the loose zone should be assumed to be equal to S_{us} . In evaluating potential measures to improve the stability of a dam or embankment where the CSR in a zone exceeds 0.15, it may be useful to perform the triggering analysis to help determine whether alternative stabilization schemes that would reduce the CSR might ultimately improve the dam or embankment stability.

For sand-like materials, evaluating the potential for triggering of strength loss using pore-pressure-based methods is done using the “simplified method” first published by Seed and Idriss (1971). The method is referred to as “simplified” because it does not require cyclic laboratory testing or detailed analysis of site response to earthquake shaking. However, use of this method for coal refuse impoundments will often require a detailed analysis of site response. Additions and updates to the method have been published by numerous authors. A consensus on the state of practice for using the method was published by 21 technical practitioners (Youd et al., 2001).

Commentary: After Youd et al. (2001) was published, several investigators proposed refinements to various aspects of the analysis method. These include Seed et al. (2003) and others. These refinements can be considered for specific cases, or Youd et al. (2001) may be used directly.

The method was developed for evaluation of the potential for a zone of sand-like material to develop high (approaching 100 percent) excess pore pressures, but may also be used as an index of the susceptibility of the soil zone to lose strength.

The method is based on observations of high pore-pressure generation during earthquakes, as evidenced primarily by the appearance of sand boils, ground fissures, or lateral spreads at level or gently sloping sites and involves computations of cyclic stress ratio (*CSR*) and cyclic resistance ratio (*CRR*). *CSR* is a measure of the seismic “demand” on a soil layer. *CRR* is a measure of the capacity of the soil to resist pore-pressure increases during earthquake shaking.

The method was developed from case history data primarily from flat to gently-sloping sites underlain with Holocene (recent) alluvial or fluvial sediments at depths less than 50 ft. The method has been verified for, and is strictly applicable only to, these site conditions (Youd et al., 2001). However, the method is often extended to other site conditions with steeper slopes and deeper soils, such as coal refuse embankments, since no directly applicable performance history is available for such facilities.

The steps for evaluating the triggering of pore-pressure increase are:

1. For the location at which each value of either SPT $N_{1,60}$ or CPT q_{t1N} was obtained in zones of material that may be susceptible to strength loss, compute the cyclic stress ratio (*CSR*), which is the average cyclic shear stress caused by the design earthquake in the zone of material divided by the initial effective vertical stress in the zone of material (τ_{av}/σ'_{v0}). Although the method was developed based on average SPT or CPT values, it should be applied to all measured values for added conservatism and improved delineation of loose zones.
2. Estimate the cyclic resistance ratio (*CRR*) from various published plots that give *CRR* as a function of $N_{1,60}$ or q_{t1N} and fines content. Alternatively, *CRR* may be computed using spreadsheets or other computer programs based on equations that approximate the curves shown in the published plots.

Commentary: For some other analyses in this chapter, corrections for fines content are not recommended, but they should be considered for estimation of *CRR* based on $N_{1,60}$ or q_{t1N} values.

3. Compute the safety factor against triggering based on pore-pressure increase using *CSR*, *CRR*, and appropriate corrections for earthquake magnitude, overburden, and shear stress using the following relationship (Youd et al., 2001):

$$FS = (CRR_{7.5}/CSR) \times MSF \times K_{\sigma} \times K_{\alpha} \quad (7-1)$$

Methods for evaluating *CSR*, *CRR*, *MSF*, K_{σ} and K_{α} are discussed below.

4. If the safety factor against pore-pressure increase in a zone is greater than 1.4, then it can be assumed that the earthquake shaking will not be strong enough to trigger strength loss in that zone. For seismic stability analyses, the peak undrained strength S_{up} (but not more than the peak drained strength) may be used in that zone. If the safety factor (CRR/CSR) in a zone is less than 1.0, then triggering of strength loss should be assumed, and for seismic stability analyses, the undrained, steady-state (residual) strength S_{us} should be used in that zone. For safety factors between 1.0 and 1.4, triggering of strength loss is possible. Either assume that triggering of strength loss will occur, or perform more rigorous triggering analyses (strain-based or stress-based methods, as discussed in Section 7.4.2.3) to make a final evaluation of whether or not triggering occurs.

Commentary: The safety factor of 1.4 is recommended guidance and is intended to account for the strength loss that can be triggered even if the pore-pressure increase is substantially lower than 100 percent.

The paragraphs that follow discuss evaluation of CSR, evaluation of CRR, and correction factors for earthquake magnitude, overburden stress, and sloping ground.

7.4.2.2.1 Evaluation of Cyclic Stress Ratio (CSR)

The cyclic stress ratio (CSR) at a particular depth is given by:

$$CSR = \tau_{av} / \sigma'_{vo} \quad (7-2)$$

where:

$$\begin{aligned} \tau_{av} &= \text{average cyclic shear stress induced by the earthquake} = 0.65 \tau_{max} \text{ (force/length}^2\text{)} \\ \sigma'_{vo} &= \text{effective vertical overburden stress (force/length}^2\text{)} \end{aligned}$$

As discussed in the following text, computing τ_{av} in a zone of material requires a design earthquake PGA or a design-earthquake, acceleration time-history.

Three methods for computing CSR that are acceptable for various situations are:

1. CSR computation method 1 – The preferred method is to compute CSR by using 1D or 2D numerical site response software, such as SHAKE or QUAD4, that compute the variation in maximum shear stress τ_{max} with depth. The value of τ_{av} at the depth of interest should be taken from the site response analyses as $0.65 \tau_{max}$ at that depth. Using a one-dimensional (1D) or two-dimensional (2D) numerical site response analysis requires, as input to the analysis, an acceleration time-history for the design earthquake as well as dynamic properties (shear modulus and damping) for each material type. This method is appropriate for all sites.

Commentary: Important material properties used in performing the analysis are the shear modulus and damping. They can be estimated using index and classification data, or site-specific testing such as crosshole testing can be performed to measure shear wave velocity (to obtain the maximum shear modulus G_{max}). Laboratory testing including resonant-column testing and cyclic-triaxial testing can also be utilized. The resonant-column test measures dynamic soil properties at a lower range of shear strain than the cyclic-triaxial test. Dynamic properties of coal refuse materials are the subject of research in Kalinski and Phillips (2008) and Zeng and Goble (2008). Whether 1D or 2D site response analyses should be used depends on the specific conditions for which the triggering analysis is being performed (locations of potential slope stability failure surfaces, variability of materials, geometric complexity, and distance from the suspect zone to the exposed slope). For analysis of upstream failures of coal refuse impoundments, the potential failure surfaces are often relatively far from the downstream face, such that the simplifications associated with 1D analyses are acceptable. For analysis of downstream failures of coal refuse impoundments with wide coarse refuse stages, the potential failure surfaces generally pass through the coarse refuse stages and possibly thin zones of fine refuse. So even though the ground surface is sloping, this geometry can be reasonably modeled with a series of 1D analyses. For analysis of downstream failures of coal refuse impoundments with narrow coarse refuse stages, the potential failure surfaces pass through highly variable materials, and the sloping ground effects (downstream face) are more pronounced. Therefore 2D analyses should be used to model these more complex conditions.

2. CSR computation method 2 (for shallow, level-ground sites) – For conditions of nearly level ground, uniform deposits, and depths up to 75 feet, CSR can be computed from the following equation (Youd et al., 2001):

$$CSR = (\tau_{av}/\sigma'_{vo}) = 0.65 (a_{max}/g) (\sigma_{vo}/\sigma'_{vo}) r_d \quad (7-3)$$

where:

- a_{max} = maximum horizontal acceleration at the ground surface (e.g., top of embankment) (mass \times length/time²)
- g = acceleration of gravity (mass \times length/time²)
- σ_{vo} = total overburden stress (force/length²)
- σ'_{vo} = effective vertical overburden stress (force/length²)
- r_d = stress reduction coefficient (1.0 at the ground surface, decreasing with depth) (dimensionless)

Commentary:

- $\tau_{av} = 0.65 \tau_{max}$
- $\tau_{max} = \text{peak seismic shear stress at any depth} = (\sigma_{vo}) (a_{max}/g) (r_d)$
- $\tau_{max}/\sigma_{vo} = (a_{max}/g) (r_d)$

τ_{max} is the product of the total overburden stress at the depth in question σ_{vo} times the peak acceleration of the overburden mass above the depth in question $(a_{max}/g)(r_d)$. This is equivalent to saying that seismic shear force equals mass times seismic acceleration or seismic shear stress (force per square foot) equals total vertical stress (mass per square foot) times seismic acceleration.

The coefficient r_d accounts for the deformability of the overburden mass, which results in the seismic shear stress at depth being lower than the product of the total overburden stress σ_{vo} times the peak acceleration at the ground surface a_{max} . In other words, r_d represents the fact that the peak acceleration of the overburden mass $(a_{max}/g)(r_d)$ at depth is lower than the maximum acceleration at the ground surface, and thus there is a reduction of the ratio of peak seismic shear stress to total overburden stress (τ_{max}/σ_{vo}) with depth. Seed et al. (2003) present refinements for values of r_d for specific cases, or Youd et al. (2001) may be used directly.

The computation of total overburden stress σ_{vo} should not include the weight of any free water that may exist above the ground surface. It is a relatively common error to include the weight of free water since it is part of the total overburden. However, it cannot be accelerated by the ground below, and thus it does not count as part of the mass being shaken.

3. **CSR computation method 3** – For depths greater than about 75 feet or for irregular and sloping ground conditions (i.e., for most coal refuse embankments), the following simplified method can, in certain cases, be used instead of Method 1. Method 3 can be used for cases where potential failure surfaces pass through relatively uniform materials, and the potential failure surfaces are relatively far from steep slopes. Examples are:
 - Upstream failures of coal refuse impoundments where the potential failure surfaces pass through reasonably uniform materials (no abrupt changes from loose or soft material to dense or hard material), and the failure surfaces are relatively far from the steep downstream slope.
 - Downstream failures of coal refuse impoundments with wide coarse refuse zones near the downstream slope, where the potential failure surfaces also pass through reasonably uniform materials.

Method 3 uses the same equation for CSR as Method 2. However, the stress reduction coefficient r_d used in that equation is only appropriate for level ground. Therefore, above the depth of interest, replace the product ($a_{max} r_d$) with the maximum acceleration of the overburden mass k_{max} . The value of k_{max} can be estimated from published relationships of the depth-dependent variation in maximum acceleration ratio (k_{max}/a_{max} versus y/h , where y is the depth below the top of the embankment and h is the embankment height). The “average of all data” line from Figure 7.4 can be used.

The maximum acceleration at the ground surface (top of embankment) a_{max} will normally be higher than the maximum acceleration at the ground surface at the base of the embankment (PGA). The value of a_{max} can be estimated from the PGA of the design earthquake at the base of the embankment using Figure 7.3.

Figures 7.3 and 7.4 were developed for conventional dams with an approximately triangular shape. Therefore, the results for Method 3 should be compared with the results of Method 2. If the results are significantly different, the more conservative value should be used, or an analysis using Method 1 should be performed.

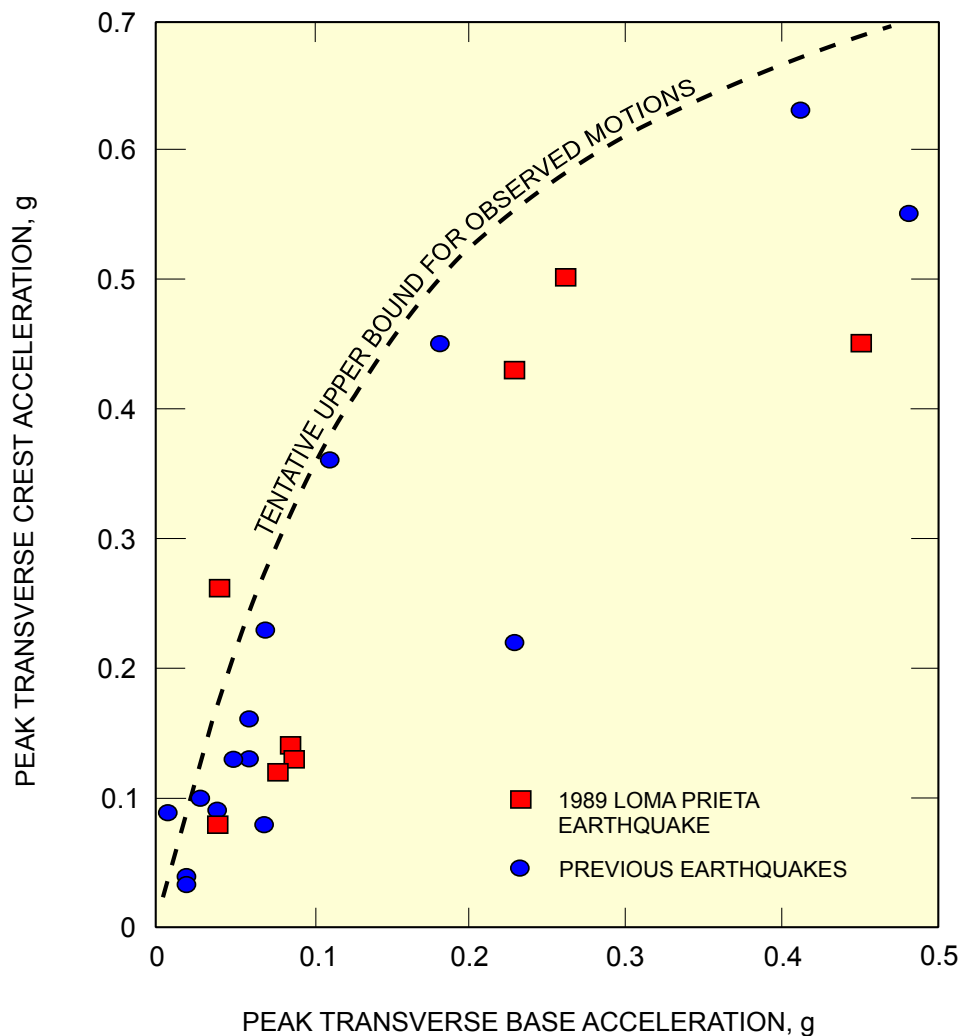

(HARDER, 1991)

FIGURE 7.3 COMPARISON OF PEAK BASE AND CREST TRANSVERSE ACCELERATIONS MEASURED AT EARTH DAMS

Commentary: It should be noted that the ratios of maximum acceleration at the base of the embankment to maximum acceleration at the top of the embankment are different in Figures 7.3 and 7.4. That is because Figure 7.4 compares the maximum acceleration of the overburden mass above the base of the embankment to the maximum acceleration at the top of the embankment, while Figure 7.3 compares the maximum acceleration at the base of the embankment to the maximum acceleration at the top of the embankment. In other words, Figure 7.4 considers that, because the overburden mass is not rigid, the accelerations at different depths within the overburden mass will be different. Figure 7.4 looks at the average acceleration of the overburden mass at each time increment and then picks the maximum value k_{max} . In Figure 7.4, k_{max} acts at the base of the overburden mass, but represents the average acceleration of the mass above the base. In Figure 7.3, the peak transverse base acceleration is the acceleration at the specific depth corresponding to the bottom of the embankment.

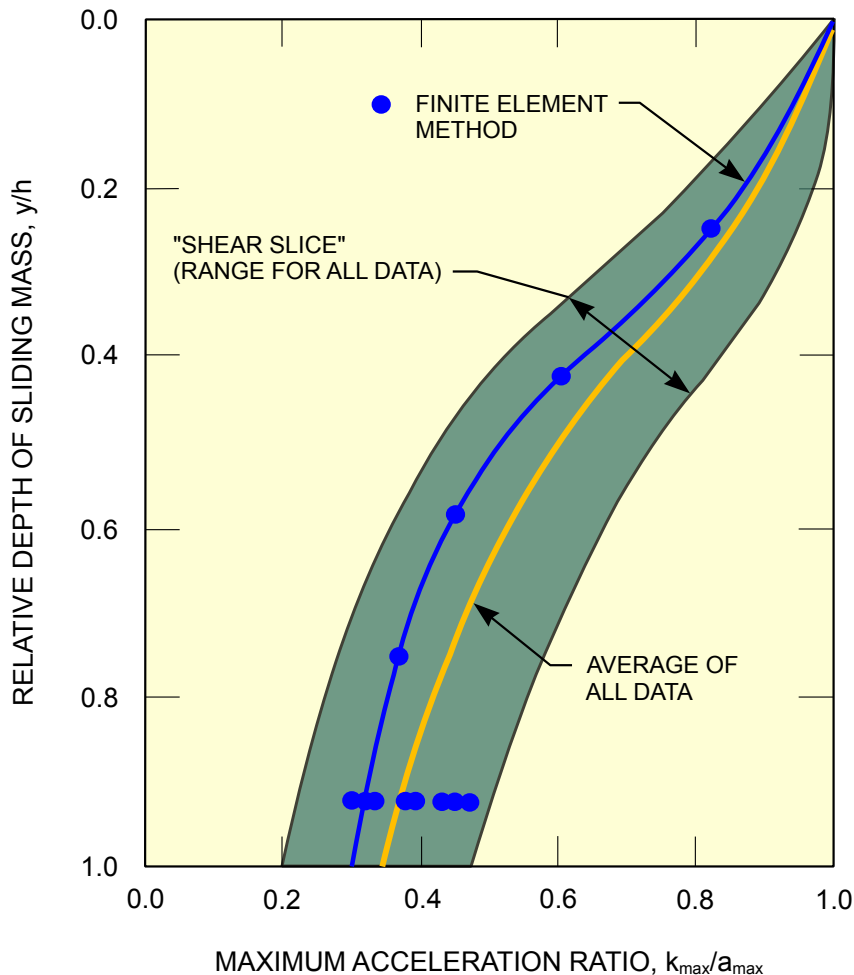

FIGURE 7.4 VARIATION OF MAXIMUM ACCELERATION RATIO WITH DEPTH OF SLIDING MASS

7.4.2.2.2 Evaluation of Cyclic Resistance Ratio (CRR)

The cyclic resistance ratio can be evaluated through the use of field test data including: (1) SPT data, (2) CPT data, and (3) shear-wave velocity (V_s) measurements. Procedures for computing CRR are described in Youd et al. (2001). It is good practice to obtain both SPT and CPT data. Shear-wave velocity data may also be helpful. A description of each of these approaches is provided in the following:

- CRR determined from SPT – Numerous plots have been published over the years showing CRR as a function of SPT blowcount $N_{1,60}$. The plot from Youd et al. (2001) is shown in Figure 7.5. The plot shows zones where data from case histories suggest

that significant pore-pressure increase will occur and zones where significant pore-pressure increase is unlikely to occur. The plot includes curves developed for soils with various percentages of fines. The curve for less than 5 percent fines is considered the basic penetration criterion for the simplified method described in Youd et al. (2001) and is thus referred to as the “SPT clean sand base curve.” Youd et al. (2001) describes ways to adjust $N_{1,60}$ to a clean sand value $N_{1,60(CS)}$. The curves are valid only for magnitude 7.5 earthquakes. Scaling factors to adjust for different magnitude earthquakes are discussed later.

Two corrections are normally made to the field blow count N . The first (C_N) is made to normalize N to an overburden pressure of 1 atmosphere (about 1 tsf or 100 kPa). The second (C_E) is made to normalize hammer energy to 60 percent of the energy generated by a 140-lb weight free-falling 30 inches. Other corrections less commonly made in practice include borehole diameter (C_B), rod length (C_R), and samplers with and without liners (C_S). Thus:

$$N_{1,60} = N \times C_N \times C_E \times C_B \times C_R \times C_S \quad (7-4)$$

The correction factors are discussed in Youd et al. (2001), which notes that the correction for overburden (C_N) becomes highly uncertain for overburden pressures greater than 3 tsf.

The presence of gravel can interfere with the penetration of the SPT sampler and lead to higher penetration resistances. One way to correct for the presence of gravel in the SPT is to record the hammer blows for every inch of penetration (rather than the standard 6 inches) as proposed by Poulos in the 1970s and described in USBR (1989) and Seed et al. (2003).

- CRR determined from CPT – Robertson and Wride (1998) developed curves of CRR as a function of dimensionless CPT tip resistance ratio q_{t1N} , as shown in Figure 7.6. The figure shows zones where data from case histories suggest that significant pore-pressure increase will occur and zones where significant pore-pressure increase is unlikely to occur. The field CPT tip resistance q_t must be normalized to an overburden pressure of 1 atmosphere (about 1 tsf or 100 kPa) to obtain q_{t1N} and must be corrected to an equivalent clean sand value $q_{t1N(CS)}$. Equations and charts for normalizing q_t and correcting to an equivalent clean sand value are discussed in Youd et al. (2001) and updated by Robertson (2004), which also includes a discussion of using average CPT values in a layer versus using all measured values. An additional correction for thin soil layers can be made, if applicable (Youd et al., 2001). The references by Robertson and Wride (1998) and Youd et al. (2001) use the uncorrected tip resistance q_c whereas, more correctly, it should be q_t . For CPT in clean to silty sands, q_c and q_t are essentially the same and are often used interchangeably.

CPTs have the advantage that they are faster to perform and typically less expensive per test than SPTs, especially in deep, soft or loose deposits, and CPTs provide a continuous, more reliable profile of penetration resistance. CPTs are particularly useful for fine coal refuse. Physical samples of the material where CPTs are conducted should be obtained for purposes of description and laboratory testing.

- CRR determined from shear-wave velocity – CRR criteria have been developed from field measurements of shear-wave velocity V_s . Shear-wave velocities can be measured

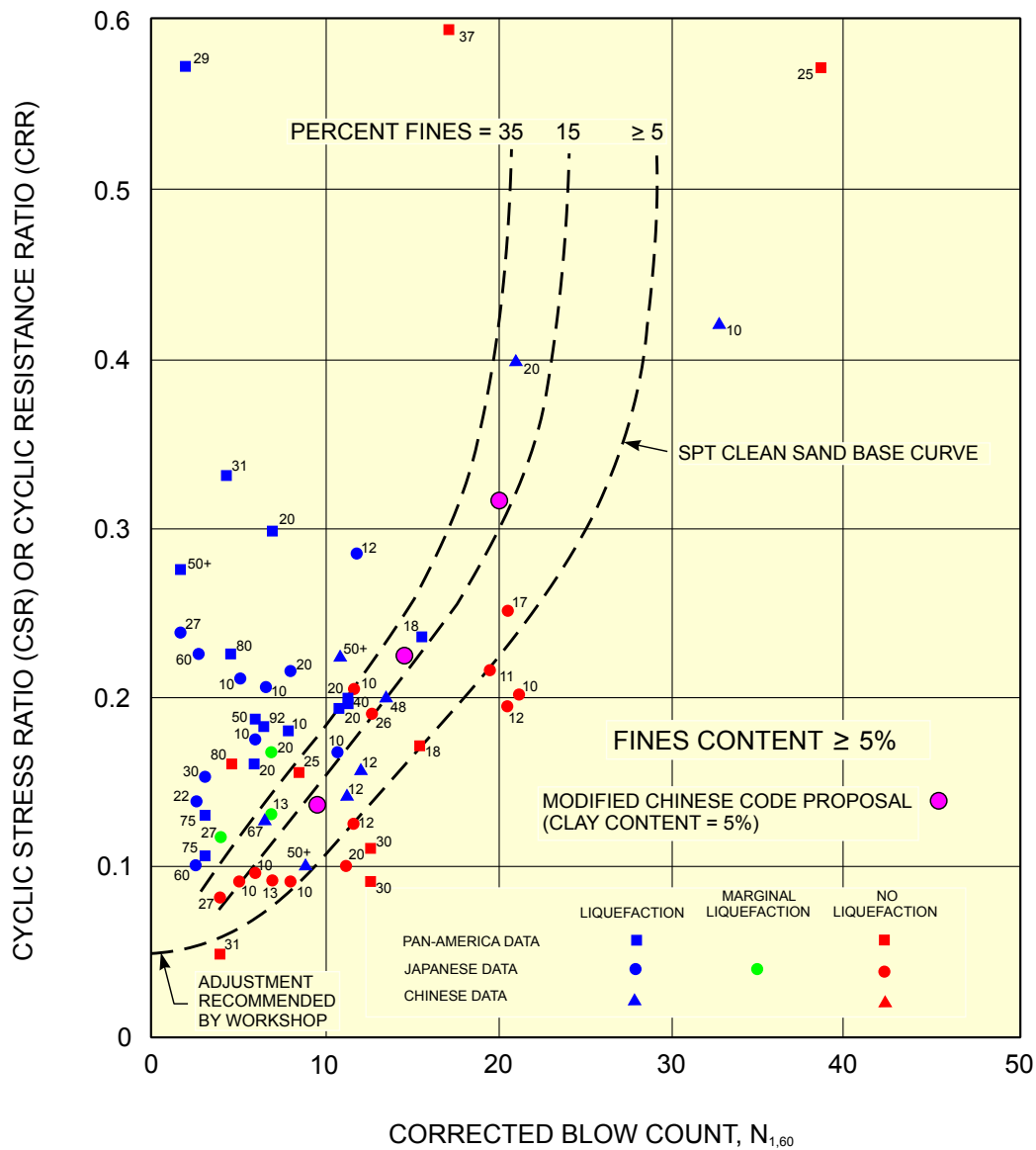

(ADAPTED FROM YOUND ET AL., 2001)

FIGURE 7.5 SPT CLEAN-SAND-BASED CURVE FOR MAGNITUDE 7.5 EARTHQUAKES WITH DATA FROM LIQUEFACTION CASE HISTORIES

using the seismic CPT (SCPT), crosshole testing, or other downhole or surface wave techniques. Crosshole testing is generally more accurate, but more expensive than seismic CPT. Potential advantages of using the shear-wave velocity are: (1) it is possible to obtain data in soils that are difficult to penetrate with CPT or SPT and (2) the shear wave velocity is directly related to small-strain shear modulus, which is a parameter required for estimating dynamic soil response. As discussed by Youd et al. (2001), concerns with the use of V_s include: (1) shear wave velocity measurements are made at small strains, whereas pore-pressure buildup and strength loss are medium to high strain phenomena and (2) thin, low shear-wave velocity layers may not be detected. V_s data, if obtained, should generally be used in conjunction with data from other methods. The shear-wave velocity obtained from the field should be normalized to a reference overburden pressure of one atmosphere. A recommended chart of CRR as a function of overburden-corrected shear wave velocity is provided in Youd et al. (2001).

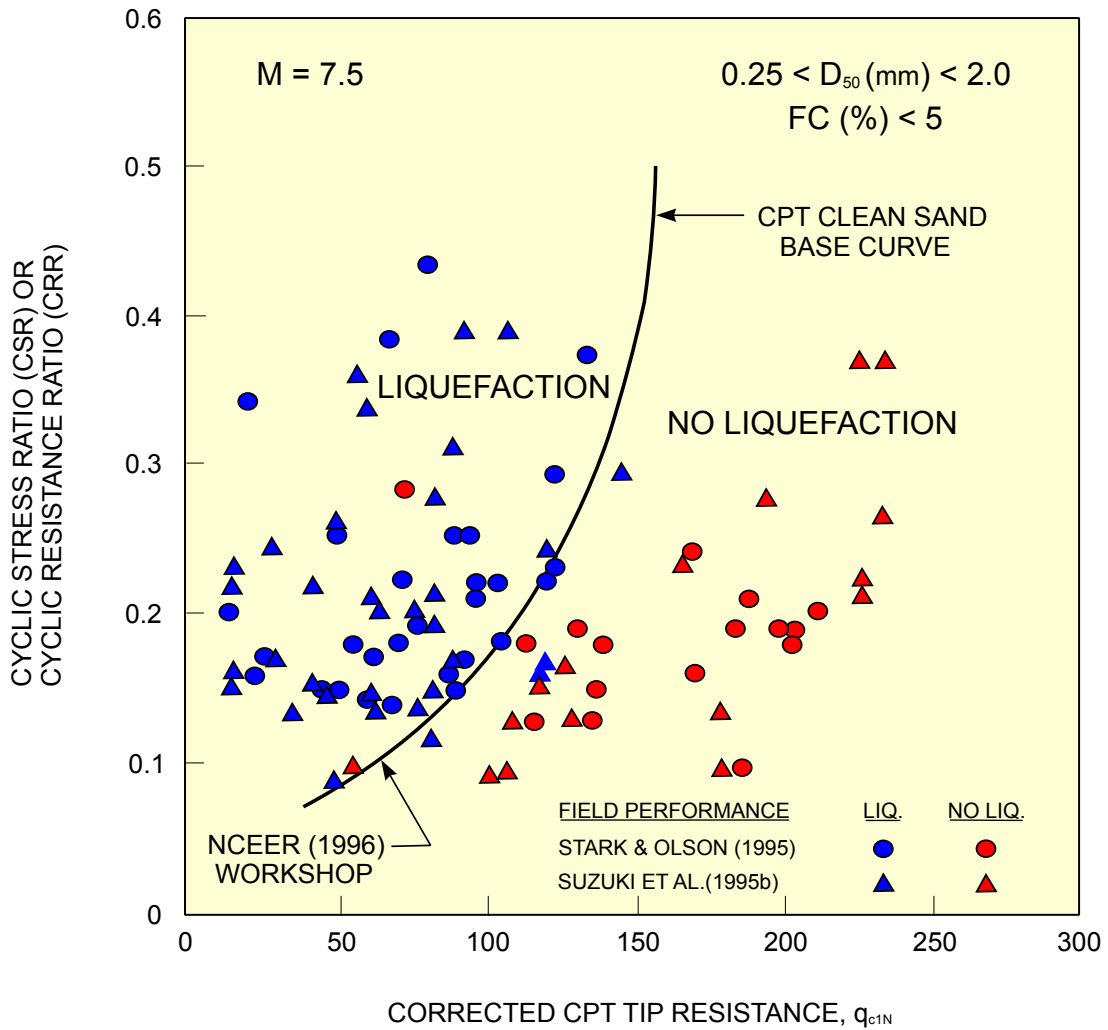

(YOU D ET AL., 2001)

FIGURE 7.6 CALCULATION OF CRR FROM CPT DATA ALONG WITH EMPIRICAL LIQUEFACTION DATA FROM COMPILED CASE HISTORIES

7.4.2.2.3 Correction Factors for Earthquake Magnitude, High Overburden, Sloping Ground and Age of Deposit

The curves used to obtain *CRR* from SPT, CPT and V_s only apply to magnitude 7.5 earthquakes. Magnitude scaling factors (MSF) have been developed to adjust the curves to smaller or larger magnitudes. The recommendations by Youd et al. (2001) represent a wide consensus among experts in the field and are preferred at this time unless project-specific factors indicate that other recommendations should be used.

The “simplified” method was developed based on case history data from gently sloping sites (low static shear stress) and depths less than about 50 feet. Correction factors (K_σ and K_α) have been developed for extrapolating the method to higher overburden pressures and steeper slopes (higher static shear stress) than those encountered in the case histories. Youd et al. (2001) caution that using these correction factors requires specialized expertise, because the current bases for selecting specific values of the correction factors are limited. If used, the cyclic resistance ratio becomes:

$$CRR = (CRR_{7.5} \times MSF) K_\sigma K_\alpha \tag{7-5}$$

Recommendations for K_σ are provided in Youd et al. (2001).

Both Youd et al. (2001) and Seed et al. (2003) discuss the wide range of values that have been proposed for K_α and explain that there are no generally agreed upon recommendations. Seed et al. (2003) recommend that the K_α values proposed by Harder and Boulanger (1997) be used where the initial vertical effective overburden pressure is less than 3 tsf. Until a consensus is reached, K_α should be taken as 1.0 unless site-specific information (laboratory test data) indicates otherwise.

It has been noted that older deposits (both older reconstituted laboratory samples and geologically older natural soil deposits) are more resistant to pore-pressure increase. However, verified correction factors have not been developed. Since it is conservative to ignore age corrections, age corrections are not recommended at this time.

7.4.2.3 Strain-Based and Stress-Based Methods to Evaluate Triggering of Strength Loss

7.4.2.3.1 Clay-Like Material: Strain-Based Method for Triggering

Soft, clay-like materials may experience strength loss during an earthquake, but the strength loss is generally not as severe as with sand-like materials (Thiers and Seed, 1968; Castro, 2003; Boulanger and Idriss, 2004). This is because clay-like materials generally reach both peak undrained strength and S_{us} at much higher strains than sand-like materials, except for highly sensitive clays where the strain to peak undrained strength can be small.

Therefore, the term “triggering” can be somewhat misleading for clay-like material. It is more correct to say that the post-earthquake strength for clays is a function of the shear strain that occurs during the earthquake. The post-earthquake strength may be the peak undrained strength or it may be a reduced strength. The post-earthquake strength could be as low as S_{us} in highly sensitive clays, but for most clay-like material the post-earthquake strength will be higher than S_{us} . The reduced strength, while higher than S_{us} , may still be low enough to result in a flow slide.

There are three approaches to estimating the post-earthquake shear strength of clay-like material:

1. Conservatively assume that the post-earthquake strength is equal to S_{us} , and estimate S_{us} from laboratory or field testing, as discussed in [Sections 7.4.3.2.2](#) and [7.4.3.3](#).
2. Estimate the post-earthquake strength as a function of earthquake-induced shear strain, using the following procedure:

- Estimate the accumulated shear strain at points along critical failure surfaces in the embankment during the earthquake. The accumulated shear strains can be estimated using Newmark-type analyses (Section 7.5.4).

Commentary: This step of this method requires that a deformation analysis be performed as part of the evaluation of post-earthquake strength. A design earthquake motion (time history of acceleration) and dynamic soil properties (modulus and damping) are required for this step.

- Obtain a relationship of post-earthquake strength as a function of total strain based on laboratory testing or other correlations as discussed in Section 7.4.3.2.2.
- Use the computed total strains during the earthquake and the relationship of post-earthquake strength versus strain during the earthquake to estimate post-earthquake strength in each zone of clay-like material.

3. Estimate the post-earthquake strength based on the earthquake-induced, cyclic shear stress. This approach involves performing cyclic-undrained, shear-strength testing (that models the earthquake loading) on undisturbed samples of the clay-like material and then loading the samples monotonically to evaluate how much the cyclic loading degraded the peak strength. This method is discussed in more detail in [Section 7.4.3.2.2](#).

7.4.2.3.2 Sand-Like Material: Strain-Based Method for Triggering

The method described in the following text is used for evaluating whether the design earthquake will produce shear strains that are high enough to cause strength loss in a zone of sand-like material.

This method is only appropriate if the safety factor against triggering using the pore-pressure-based method (CRR/CSR) is between 1.0 and 1.4. If the safety factor is higher than 1.4, then triggering may be assumed to not occur. If the safety factor is less than 1.0, then triggering should be assumed. For safety factors between 1.0 and 1.4, the pore-pressure-based method indicates that triggering is likely, but this strain-based method may indicate that triggering will not occur.

As discussed in Section 7.4.1, if the design PGA is larger than 0.2g and the CSR in the loose zone is greater than 0.15, then the triggering analysis described in the following text should not be performed, and triggering of strength loss in the loose zone should simply be assumed. The post-earthquake strength of the material in the loose zone should be assumed to be equal to S_{us} . In evaluating potential measures to improve the stability of a dam or embankment where the CSR in a zone exceeds 0.15, it may be valuable to perform the triggering analysis to help assess whether alternative stabilization schemes that would reduce the CSR might ultimately improve the dam or embankment stability.

The discussion that follows is based primarily on Castro (1994), which should be consulted for further details. The steps in the method are:

1. Select one or more potential failure surfaces through the embankment. Estimate the total seismically-induced shear strain along the critical failure surfaces in the embankment during the earthquake. Failure surfaces that had the lowest safety factors in the post-earthquake stability analysis performed when triggering of loose material was assumed should be selected. The total shear strains include: (1) transient cyclic strains, which can be estimated by a 1D or 2D site-response analysis using SHAKE or QUAD4 and (2) accumulated strains, which can be estimated using Newmark-type analyses ([Section 7.5.4](#)) or numerical modeling ([Section 7.5.5](#)). To be conservative, the total seismically-induced shear strain should be computed by adding the maximum transient cyclic strain to the total accumulated strain.

If numerical modeling is used to estimate accumulated strain, the model output will include shear strains. If a Newmark-type analysis is used to estimate accumulated strains, the analysis will provide displacements. To convert displacements to shear strains, the thickness of the loose zone should be estimated, and the strains should be assumed to be uniform across the full thickness of the zone. In other words, the shear strain will be approximately equal to the displacement divided by the thickness of the zone. A Newmark-type analysis can be used instead of numerical modeling only for cases in which the loose zone is relatively thin compared to the overall failure mass.

Commentary: A design earthquake motion (time history of acceleration) is required for performing the deformation analysis required for this step.

2. The triggering shear strain of sand-like material is approximately equal to the shear strain at peak strength in undrained monotonic (non-cyclic) loading. However, for

the triggering analysis, conservatively assume that the triggering shear strain is equal to one-half the shear strain at peak strength in monotonic, strain-controlled undrained laboratory strength tests. (Shear strain is equal to 1.5 times the axial strain in triaxial tests.)

Perform undrained shear tests on samples consolidated anisotropically to stresses corresponding to the static anisotropic stresses along the potential failure plane through the embankment.

Undisturbed samples should normally not be used for this testing because of concern for densification during sampling, handling, and laboratory consolidation to the point that the samples are not as contractive in the laboratory as the in-situ material. Remolded samples should generally be used, attempting to bracket (after being anisotropically consolidated in the lab) void ratios (more correctly – relative densities) that reflect field conditions. Representative samples from the zone of interest should be mixed to obtain a batch of soil for remolded testing. The samples that are mixed should have similar grain size distribution. (As an example, clean sand material should not be mixed with material containing more than about 20 percent fines). Remolded samples can be prepared by moist tamping in multiple layers or by wet or dry pluviation. Pluviation may not be appropriate for silty samples because of the potential for material segregation by particle size.

Commentary: The strain to peak strength and the triggering strain vary with the degree of anisotropic consolidation. Therefore, to model field conditions, anisotropic consolidation is required for these tests. In contrast, for identical specimens consolidated to the same void ratio, the steady-state (residual) strength S_{us} measured in the laboratory will be the same for isotropically- and anisotropically-consolidated specimens. Therefore, for convenience, S_{us} testing is normally performed on isotropically-consolidated specimens, as discussed in [Section 7.4.3.2.3](#).

The recommendation to estimate the triggering shear strain as being equal to one-half the shear strain at peak undrained strength in a monotonic test is conservative. Being conservative at this step is appropriate because of: (1) the low shear strain required to reach peak undrained strength indicates a high potential for progressive failure and (2) the evaluation of seismically-induced shear strains is highly uncertain.

Instead of performing laboratory strength tests, the shear strain at peak undrained strength could be estimated as a function of the ratio of vertical to horizontal consolidation stress from published data for similar sand-like material (Castro 1994). The triggering shear strain would then be assumed to be equal to one-half the estimated shear strain at peak undrained strength. However, at this time, there is not adequate published data available to rely on, so either: (1) site-specific laboratory testing should be performed or (2) the triggering shear strain of the sand-like material can simply (conservatively) be assumed to be 0.25 percent. This recommended shear strain is a lower bound for the data presented in Castro (1994) for consolidation stress ratios typical of coal refuse impoundments.

3. If the total computed seismically-induced shear strain along the critical failure surface is less than the shear strain needed to trigger strength loss, as estimated from: (1) laboratory testing, (2) comparisons to published data on similar materials, or (3) simply taken as 0.25 percent, then strength loss will not be triggered. Use the peak undrained shear strength (or the drained strength, whichever is lower) in the stability analyses. If the total seismically-induced shear strain is greater than the triggering shear strain, use S_{us} in the stability analyses.

7.4.2.3.3 Sand-Like Material: Stress-Based Method for Triggering

This method is used to evaluate whether the design earthquake will produce shear stresses in a zone of sand-like material that are high enough to cause strength loss in that zone. The basic concept of the method is that strength loss will be triggered by earthquake shaking if the sum of the static (gravity) shear stresses along a potential failure surface plus the seismic shear stresses exceed the yield (peak) undrained strength $S_u(\text{yield})$.

This stress-based method for triggering is only appropriate if the safety factor (CRR/CSR) against triggering determined from the pore-pressure-based method is between 1.0 and 1.4. If the safety factor is greater than 1.4, then triggering can be assumed to not occur. If the safety factor is less than 1.0, then it should be assumed that triggering will occur. For safety factors between 1.0 and 1.4, the pore-pressure-based method indicates that triggering is likely, but this stress-based method may indicate that triggering will not occur.

As discussed in Section 7.4.1, if the design PGA is greater than 0.2g and the CSR is greater than 0.15, then the triggering analysis described in the following text should not be performed, and strength loss for loose sand-like material should simply be assumed. The post-earthquake strength of the material in the loose zone should be assumed equal to S_{us} . If evaluating potential measures to improve the stability of a dam or embankment where the CSR in a zone exceeds 0.15, it may be valuable to perform the triggering analysis to help assess whether alternative stabilization schemes that would reduce the CSR might ultimately improve the dam or embankment stability.

The methodology described in the following steps is based primarily on Olson and Stark (2003), which should be consulted for further details. The steps are:

1. Perform a slope stability analysis to estimate the static shear stress $\tau_{driving}$ in the loose zone of sand-like material. This is accomplished by varying the assumed undrained strength of the material in the zone until a safety factor of one is achieved. For denser soils, the peak drained or undrained strength should be used, as discussed in Section 7.4.4.3.
2. Divide the critical failure surface into 10 to 15 segments.
3. Compute the weighted average σ'_{vo} along the failure surface and calculate the average static shear stress ratio $\tau_{driving}/\sigma'_{vo}$.
4. Estimate the average seismic shear stress $\tau_{av, seismic}$ applied to each segment of the failure surface using a 1D or 2D site response analysis as provided by SHAKE or QUAD4. The value of $\tau_{av, seismic}$ for each segment of the failure surface can be taken as 0.65 times τ_{max} obtained from the site response analysis.
5. Estimate the value of $S_u(\text{yield})/\sigma'_{vo}$ from CPT or SPT data using the proposed equations in Olson and Stark (2003). The equations give a range of ratios based on SPT or CPT data. The median value of SPT or CPT data should be used for each zone, and the lower bound of Olson and Stark's equation should be used to compute the ratio of $S_u(\text{yield})/\sigma'_{vo}$.

Commentary: The equations are based on back-calculations of yield (peak) undrained strength from failure case histories where the failures were triggered by static, not seismic, loading. Therefore, the back-calculated strengths represent yield (peak) undrained strengths.

6. Compute values of $S_u(\text{yield})$ and $\tau_{driving}$ for each segment along the failure surface, based on the values of $S_u(\text{yield})/\sigma'_{vo}$ and $\tau_{driving}/\sigma'_{vo}$ (average) and the value of σ'_{vo} for each segment.

7. Compute the factor of safety against triggering for each segment as:

$$FS_{\text{triggering}} = S_{u(\text{yield})} / (\tau_{\text{driving}} + \tau_{\text{av, seismic}}) \quad (7-6)$$

8. Assume that triggering of strength loss occurs for segments where $FS_{\text{triggering}}$ is less than or equal to 1.0. Assume that triggering of strength loss does not occur for segments where $FS_{\text{triggering}}$ is greater than 1.0.

7.4.3 Evaluation of Post-Earthquake Strength

7.4.3.1 Correlations of SPT and CPT with S_{us} of Sand-Like Material

Loose, sand-like refuse and sand-like natural soil may experience significant strength loss due to earthquake shaking, if the shaking is strong enough. The reduced strength is the undrained steady-state (residual) strength S_{usr} , which is often much lower than the peak undrained strength or the peak drained strength. Table 7.2 presents references for several correlations of S_{us} with SPT data ($N_{1,60}$) and CPT data (q_{t1}) for sand-like material.

The correlations are based on back-calculated values of S_{us} from actual flow slides and measured or estimated values of $N_{1,60}$ or q_{t1} . The correlations are generally limited to $N_{1,60}$ values (uncorrected for fines) less than about 12 or q_{t1} less than about 75 tsf because no flow slides have been reported for soils with higher penetration resistances. For higher values of $N_{1,60}$ and q_{t1} , the drained strength should be used because, as discussed in Section 7.4.4.2, the material is dilative.

The Seed and Harder (1990) plot (Figure 7.7) is probably the most well known of the S_{us} versus SPT or CPT correlations. The plot is an update of an earlier plot presented in Seed (1987). The 1990 plot includes a correction to increase $N_{1,60}$ values for silty materials to “equivalent clean sand” $N_{1,60(CS)}$ values. The correction varies from 1 to 5 blows per foot depending on the percent fines. However, no basis for this correction is provided in either the 1990 or 1987 paper.

TABLE 7.2 REFERENCES FOR CORRELATIONS OF S_{US} WITH SPT AND CPT DATA

Reference	Correlated Parameters
Seed (1987)	S_{us} vs. $N_{1,60}$
Davis, Castro and Poulos (1988)	S_{us} vs. $N_{1,60}$
Seed and Harder (1990)	S_{us} vs. $N_{1,60}$
Baziar and Dobry (1995)	S_{us} and S_{us}/σ'_v vs. $N_{1,60}$
Castro (1995)	S_{us} vs. $N_{1,60}$
Wride, McRoberts and Robertson (1999)	S_{us} and S_{us}/σ'_v vs. $N_{1,60}$
Yoshimine, Robertson and Wride (1999)	S_{us}/σ'_v vs. $q_{c1N(CS)}$
Olson and Stark (2002)	S_{us}/σ'_v vs. $N_{1,60}$ and q_{t1}
Idriss and Boulanger (2007)	S_{us} and S_{us}/σ'_v vs. $N_{1,60}$ and $q_{c1N(CS)}$

Note: S_{us} = Undrained steady state (residual) strength.

$N_{1,60}$ = Standard Penetration Test (SPT) N-value, normalized to an effective overburden stress of one atmosphere (typically 1 tsf) and normalized to a hammer efficiency of 60 percent.

S_{us}/σ'_v = Undrained steady state strength normalized to vertical effective stress.

$q_{c1N(CS)}$ = Cone Penetration Test (CPT) tip resistance normalized to a reference pressure of one atmosphere and corrected to an equivalent value for clean sand.

q_{t1} = CPT tip resistance normalized to an effective overburden stress of one atmosphere.

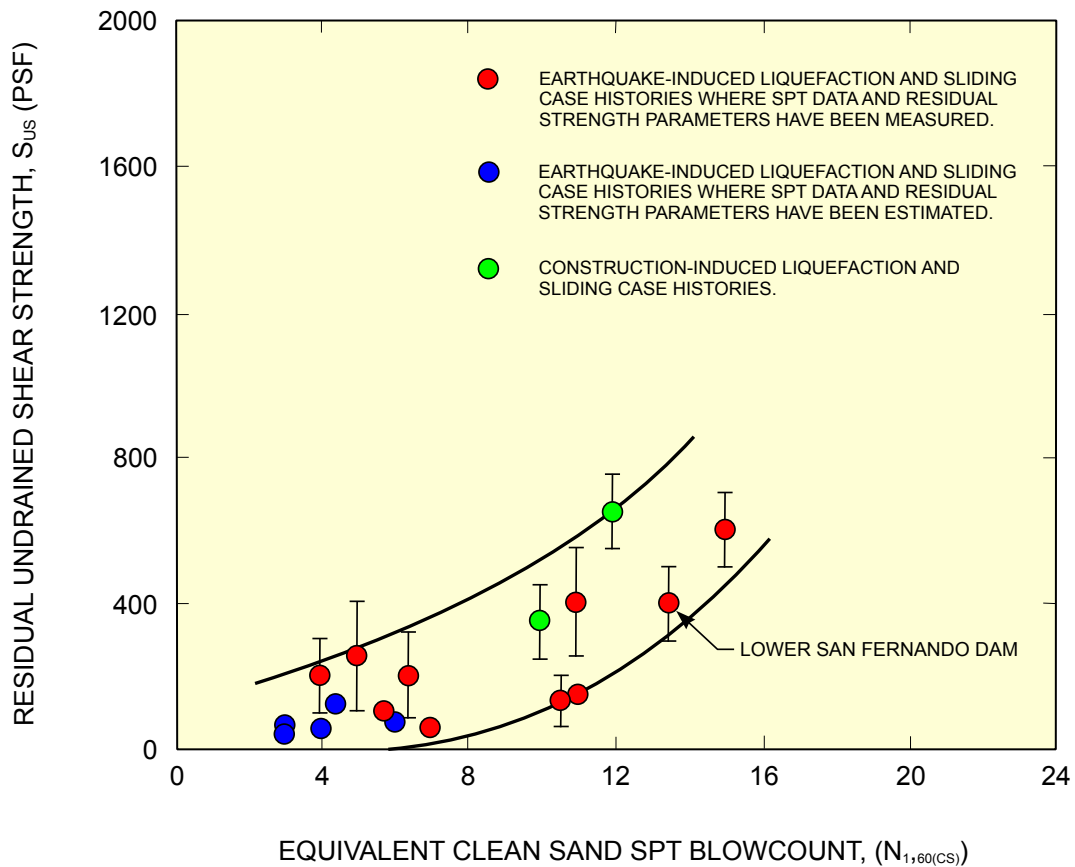

(ADAPTED FROM SEED AND HARDER, 1990)

FIGURE 7.7 S_{us} versus $N_{1,60(CS)}$

Castro (1995) re-evaluated several of the case histories in Seed and Harder (1990) for which detailed data were available. He also collected re-evaluations of some of the earlier case histories performed by Poulos (1988) and Davis et al. (1988). He referred to the re-evaluations collectively as the GEI data. Castro then replotted the Seed and Harder data points (without a fines correction) and compared them to the GEI data points. The resulting plot of representative $N_{1,60}$ values and back-figured S_{us} is shown in Figure 7.8. The original Seed and Harder (1990) lower-bound curve is somewhat lower than the Seed and Harder lower-bound curve shown in Castro (1995) because the original Seed and Harder curve included a fines correction while the Seed and Harder curve shown in Castro (1995) did not.

Correlations of S_{us}/σ'_v versus SPT and CPT data, back-calculated from case histories, are listed in Table 7.3. Olson and Stark (2002) re-evaluated the Seed and Harder (1990) data and added new case histories for development of plots of S_{us}/σ'_v versus both $N_{1,60}$ and q_{t1} . Olson and Stark did not include a fines correction to the $N_{1,60}$ values as Seed and Harder did. Olson and Stark's plot of S_{us}/σ'_v versus q_{t1} is shown as Figure 7.9. A reasonable lower bound of the Olson and Stark data is a ratio of S_{us}/σ'_v equal to 0.04, which is independent of SPT or CPT value.

Idriss and Boulanger (2007) re-evaluated the Seed and Harder case histories and the Olson and Stark case histories, and included the fines correction to the $N_{1,60}$ values as Seed and Harder did. Idriss and Boulanger recommended design curves for both S_{us} versus $N_{1,60(CS)}$ and S_{us}/σ'_v versus $N_{1,60(CS)}$. Idriss and Boulanger's design curve for S_{us} versus $N_{1,60(CS)}$ is in between the upper and lower bounds suggested by Seed and Harder in Figure 7.7.

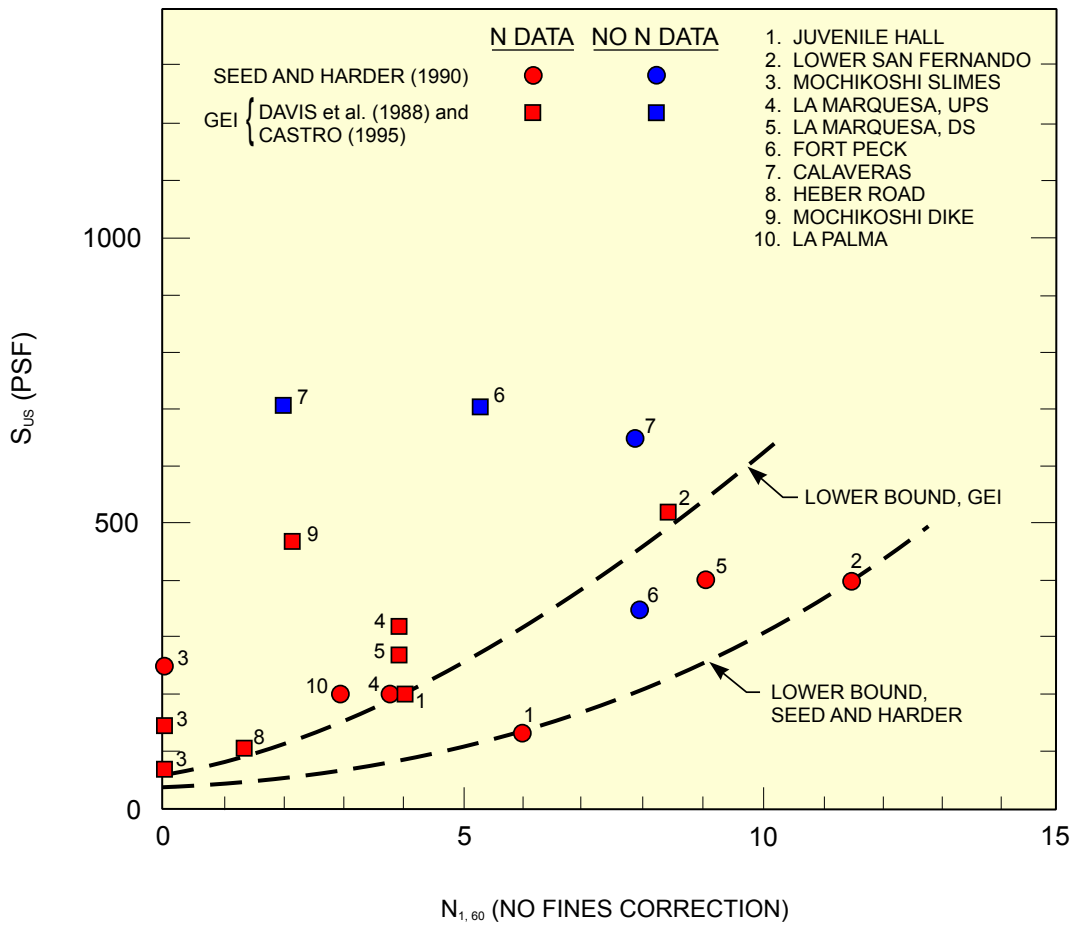

(CASTRO, 1995)

FIGURE 7.8 S_{us} versus $N_{1,60}$

TABLE 7.3 CORRELATIONS OF S_{US}/Σ'_V VERSUS SPT AND CPT DATA BACK-CALCULATED FROM CASE HISTORIES

Reference	Reported S_{us}/σ'_v	Types of Data and Materials
Baziar and Dobry (1995)	0.04 to 0.20	Back-calculated values from failure case histories for 9 sites with silty sand or sandy silt material (more than 10 percent fines). One of the 9 sites was identified as a tailings dam.
Yoshimine, Robertson and Wride (1999)	0.03 to 0.19	Back-calculated values from case histories involving multiple submarine slides at 3 sites. Materials were natural clean sand, silty sand, and sandy silt.
Olson and Stark (2002)	0.05 to 0.12 (proposed limits of ratios)	Back-calculated values from 33 failure case histories, including re-evaluation of the Baziar and Dobry sites. Four of the 33 sites were identified as tailings dams as compared to dams or slopes consisting of natural soils. Four of the 33 sites, including one of the tailings dam sites, had ratios of 0.02 to 0.04, outside their proposed boundary.
Idriss and Boulanger (2007)	0.05 to 0.22	Back-calculated values based on select case histories published by Seed (1987), Seed and Harder (1990), and Olson and Stark (2002) with adequate amount of in-situ measurements and reasonably complete geometric details (7 of the 35 case histories reviewed).

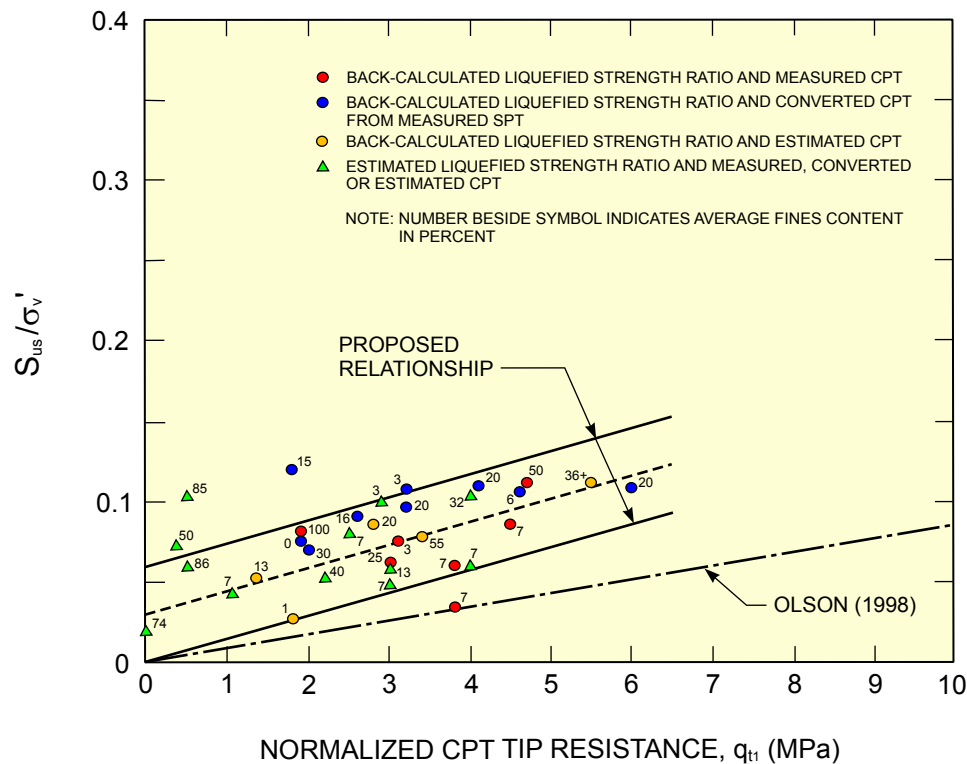

(ADAPTED FROM OLSON AND STARK, 2002)

FIGURE 7.9 S_{us}/σ'_v versus q_{t1}

Idriss and Boulanger's design curve for S_{us}/σ'_v versus $N_{1,60(CS)}$ is very close to the best fit line suggested by Olson and Stark in the range where $N_{1,60(CS)}$ is less than about 14. For $N_{1,60(CS)}$ values higher than about 12 to 14, which is beyond the range of the case history data, Idriss and Boulanger suggest two curves: one for the case where "void ratio redistribution effects" are negligible, and one for the case where void ratio redistribution effects may be significant. The difference between these two curves is discussed in the following commentary.

Commentary (Use of S_{us}/σ'_v Ratios): Using the ratios of S_{us}/σ'_v for confining pressures significantly higher than the confining pressures from the actual case histories may be unconservative. Twenty-eight of Olson and Stark's 33 case histories had mean σ'_v of 115 kPa or less. This corresponds to mean σ'_v of up to 2,400 psf or, for an assumed effective unit weight of 55 pcf, a mean depth of up to 45 feet. Using S_{us}/σ'_v ratios implies that increasing the confining pressure by a factor of 5, for example, would also increase S_{us} by a factor of 5. But laboratory testing has shown that the slope of the void ratio versus $\log S_{us}$ line is often steeper than the slope of the void ratio versus $\log \sigma'_v$ line. In other words, increasing the confining pressure by a factor of 5 often results in increasing S_{us} by a factor less than 5. So using the S_{us}/σ'_v ratios for high confining pressures may be unconservative. Therefore, recommended guidance is to consider only the lower-bound ratio of 0.04. The lower-bound ratio of $0.04 \sigma'_v$ is considered conservative enough that it is acceptable even at high confining pressures.

The lower bound ratio of 0.04 is applicable to non-plastic materials and to materials with a liquidity index (LI) of less than one. Materials with $LI > 1$ are unusual, but may have even lower values of S_{us} . At this time, the recommended lower bound value of S_{us} for soils with $LI > 1$ is 20 psf, but no higher than obtained with a strength ratio of 0.04, based on the judgment of the authors of this chapter.

The correlations of S_{us} with $N_{1,60}$ have uncertainty at high confining pressures because the correction factors used to correct N to N_1 to account for increasing confining pressure are highly uncertain at confining stresses

higher than about 2 tsf (Youd et al., 2001). However, the uncertainty of applying the S_{us} versus $N_{1,60}$ correlations at high confining stresses is less than the uncertainty of applying the correlations of SPT or CPT with S_{us}/σ'_v ratios.

Commentary (Void Ratio Redistribution): The phenomenon of void ratio redistribution is discussed in Section 7.4.5. It refers to the possibility that if a loose zone of sand-like material is overlain by an impervious zone, then earthquake shaking may cause pore water to migrate toward the interface of the two materials, which could result in the sand-like material becoming looser and therefore having a lower steady-state strength. There are no generally accepted methods for evaluating the potential for this to occur, and there is some controversy as to whether it actually occurs in the field at all.

The Idriss and Boulanger (2007) design curve for S_{us}/σ'_v versus $N_{1,60(CS)}$ splits at values of $N_{1,60(CS)}$ higher than about 12 to 14. For the case where void ratio redistribution effects are negligible, S_{us}/σ'_v increases rapidly as $N_{1,60(CS)}$ increases above 12 to 14. This is consistent with the fact that sand-like material with $N_{1,60(CS)}$ values higher than 12 to 14 tend to be dilative and not susceptible to strength loss (as discussed in more detail in Section 7.4.4.2.1). For the case where void ratio redistribution effects may be significant, S_{us}/σ'_v increases less quickly as $N_{1,60(CS)}$ increases. As Idriss and Boulanger explain, the curve for this case is largely conceptual, since there are no case history data at these $N_{1,60}$ values.

For the purposes of this Manual, and as discussed further in Section 7.4.5, specific evaluations for potential void-ratio redistribution effects are not required. As discussed in Section 7.4.4.3, the post-earthquake strength of sand-like material with $N_{1,60}$ greater than or equal to 15 may be based on the drained strength and not on correlations of S_{us} or S_{us}/σ'_v to $N_{1,60}$. However, if redistribution is a concern, the corresponding Idriss and Boulanger curve can be used.

For estimating S_{us} values of sand-like materials based on correlations to SPT and CPT data, the following three-step procedure is recommended:

1. For each zone of material, determine a representative value of $N_{1,60}$. In general, the representative value should be the median value. For this step, CPT data can be converted to $N_{1,60}$ using the relationships discussed in Section 6.4.3.7 (Lunne et al., 1997).
2. Use either the “Lower-Bound, GEI” curve or the “Lower-Bound, Seed and Harder” curve from the Castro (1995) plot (Figure 7.8) to obtain S_{us} as a function of representative value of $N_{1,60}$. Both curves can be extrapolated to values of $N_{1,60}$ as high as 14 by extending the curves along approximately straight lines. As discussed in Section 7.4.4.3, drained strength, rather than S_{us} , can be used for $N_{1,60}$ values of 15 or higher.
3. For each zone, if the resulting value of S_{us} is less than $0.04 \sigma'_v$, use $S_{us} = 0.04 \sigma'_v$ instead.

Commentary: As discussed in Section 7.4.1, S_{us} of sand-like material is very sensitive to small changes in void ratio. CPTs and SPTs are not sensitive to small changes in void ratio, and therefore correlations of CPT and SPT to S_{us} are expected to have large scatter, as shown in Figures 7.7, 7.8, and 7.9. The S_{us} versus SPT or CPT correlations provide conservative estimates of S_{us} . Generally S_{us} is not directly related to either $N_{1,60}$ or q_{t1} . The case histories used in these correlations are cases where S_{us} was low enough that a flow slide or significant deformations occurred. However, there were almost certainly other sites where $N_{1,60}$ or q_{t1} were similar, but flow slides or significant deformations did not occur because S_{us} was higher than obtained from the failure case histories. Cases where stability failure did not occur could provide lower-bound estimates of S_{us} (i.e., the minimum value of S_{us} needed to maintain stability), but these cases are not typically studied and would still provide only conservative estimates. Laboratory testing methods for estimating S_{us} may provide less conservative estimates of S_{us} .

7.4.3.2 Laboratory Testing for Measuring Post-Earthquake Strength for Clay-Like Material and S_{us} for Sand-Like Material

7.4.3.2.1 Laboratory Testing Issues

Soil fabric has been shown in the literature to affect the peak undrained strength of sand-like material. This often results in different peak undrained strengths for undisturbed samples versus reconstituted samples. However, initial soil fabric should not affect S_{us} , because S_{us} is measured at high strains after the soil fabric has become remolded. An example of this is presented in Castro, Seed, Keller, and Seed (1992). Samples of hydraulic sand fill prepared from slurry and by moist tamping had the same steady-state line.

There is extensive published research that shows that, for peak-undrained strength of clayey soils: S_u (triaxial compression) $>$ S_u (direct simple shear) $>$ S_u (triaxial extension). However, there are no data to suggest whether or not steady-state (residual) strength S_{us} varies with test type. The difficulty is that test methods other than triaxial compression can not generally be run to high enough strain levels to reach S_{us} before non-uniformities in the specimen become so large that the test data lose meaning. Triaxial extension tests experience necking at relatively low strains. Direct simple shear tests have significant stress non-uniformities (at all strains) because there are no vertical shear stresses (and therefore no horizontal shear stresses) at the outside edges of the specimen. Investigators who have tried to evaluate the effect of test type on measured S_{us} of sand-like material have encountered these difficulties, which make it difficult to identify S_{us} on stress-strain curves from tests other than triaxial compression.

It is reasonable that the peak strength varies with test type, because the peak strength is very much dependent on soil structure and therefore on the method of loading. For S_{us} , however, the initial soil structure has been lost (remolded) due to the high strain, so the method of loading should not be as significant. While there might be a difference in S_{us} for sand-like material related to the fact that the intermediate principal stress varies depending on the test type, this difference will be small compared to the variation in steady-state strength that one should expect for different samples from the same layer or zone of material. Expected in-situ strength variation was previously discussed in [Section 7.4.1](#).

For most clay-like material, S_{us} is such a conservative estimate of post-earthquake strength that minor differences that may or may not be a function of test type do not seem significant. In any event, the S_{us} value for clay-like soils cannot be measured using triaxial (compression or extension) or direct simple-shear tests, because the strain to S_{us} is so high. Testing of clay-like material to estimate post-earthquake strengths that are closer to S_{up} involves using cyclic loading followed by static loading, as discussed in [Section 7.4.3.2.2](#). For this testing procedure, differences in strength between triaxial compression and other test types should be small compared to the variation in strength one should expect for different samples from the same layer. However, one could, if desired, use direct simple-shear testing or correct the triaxial test strengths to equivalent direct simple-shear strengths using the information in Article 20 of Terzaghi, Peck, and Mesri (1996).

Based on the preceding discussion, the use of triaxial compression testing to estimate S_{us} for sand-like material, and to estimate post-earthquake strength for clay-like material, as discussed in [Sections 7.4.3.2.2](#) and [7.4.3.2.3](#), is reasonable.

7.4.3.2.2 Laboratory Testing of Soft Clay-like Material to Measure Post-Earthquake Strength

As discussed in [Section 7.4.2.3.1](#), the post-earthquake strength for clay-like material is a function of the shear strains that occur during the earthquake. The post-earthquake strength may be the peak undrained strength S_{up} or it may be a reduced strength. The post-earthquake strength could possibly (but not likely) be as low as S_{us} .

A conservative estimate of post-earthquake strength for soft clay-like materials is to use S_{us} , which can be obtained by performing field vane-shear tests and/or CPTs, as described in [Section 7.4.3.3](#). A less conservative estimate can be obtained by performing laboratory testing to obtain an undrained strength that is appropriate based on considerations of accumulated strain and/or cyclic stress level. As discussed in [Section 7.4.4.3](#), the post-earthquake strength of stiff clay-like material can be taken as the peak-undrained strength.

If laboratory testing is performed, strain-controlled, undrained-triaxial (or perhaps undrained direct simple-shear) tests should be performed to measure: (1) the peak undrained strength, (2) the shear strain to peak undrained strength, and (3) the drop-off in shearing resistance with continued strain after peak. It should be remembered that shear strain in the triaxial test is 1.5 times the axial strain and that peak strength refers to the peak principal stress difference. Test specimens should be consolidated anisotropically to stresses that model in-situ conditions.

If the shear strain at peak strength is less than about 5 percent, or if the shearing resistance drops off significantly after peak, then either: (1) measure S_{us} (in the laboratory or the field) and use it as a conservative estimate of post-earthquake strength, (2) perform a series of laboratory tests with cyclic loading followed by monotonic loading to obtain a less conservative estimate of post-earthquake strength based on the strain that occurs during cyclic loading, or (3) perform a series of laboratory tests with cyclic loading followed by monotonic loading to obtain a less conservative estimate of post-earthquake strength based on the cyclic stress levels applied by the design earthquake. Details for these options are discussed in the following text. Note that the number of loading cycles in the cyclic loading sequence must be appropriate compared to the number of representative loading cycles associated with the design earthquake magnitude. Seed and Idriss (1982) correlated the number of representative loading cycles with earthquake magnitude (e.g., $M = 6.5$, $N = 10$; $M = 7.5$, $N = 15$; and $M = 8.5$, $N = 26$, where M is earthquake magnitude and N is the number of representative loading cycles).

If the shear strain at peak strength is more than 5 percent, and there is little drop-off in shearing resistance after peak, then options (1), (2), and (3) discussed in the preceding paragraph can be used. However, a simplified version of option (2) can also be used. If the seismically-induced shear strains, as described in Step 2a, are less than one-half the shear strain to peak strength in the monotonic (static) test, then the post-earthquake undrained strength can be assumed to be equal to the peak undrained strength S_{up} . This is based on previous testing of clay-like materials (Thiers and Seed, 1968; Castro and Christian, 1976; Castro, 2003).

The three options for evaluating the post-earthquake strength of clay-like material are:

1. Conservatively assume that the post-earthquake strength is S_{us} and measure S_{us} . To measure S_{us} in the field, CPT or field vane tests can be used, as discussed in [Section 7.4.3.3](#). To measure S_{us} in the laboratory, vane-shear tests can be used. The strain rate should be high to ensure that the sample is being sheared undrained and that the undrained S_{us} is being measured (see discussion of field vane-shear rates in [Section 6.4.3.8](#)). S_{us} cannot normally be reached for clay-like material (except highly sensitive clays) within the strain limitations of laboratory tests, other than possibly rotation shear. Since it is unlikely that the post-earthquake strength will be reduced to S_{us} except in highly sensitive clays, laboratory testing to measure S_{us} of clay-like material may not be needed in practice.
2. Measure the relationship between cyclic strain and post-earthquake strength. Anisotropically-consolidated, undrained-triaxial tests (or perhaps undrained, direct simple-shear tests, also consolidated with an initial shear stress), with cyclic loading followed by monotonic loading, can be used to obtain the relationship between accumulated shear strain during the earthquake and post-earthquake, undrained

strength. Accumulated strain is a measure of the effects of cyclic loading on the post-earthquake strength of clay-like material. After low accumulated strains, the post-earthquake strength will be close to the peak-undrained strength. After very high accumulated strains, the post-earthquake strength may be close to S_{us} . Instead of accumulated strain, peak strain could also be used as a measure of the effects of cyclic loading. However, the use of accumulated strains is recommended. A procedure for performing this type of testing is described in Castro (2003). The basic steps are:

- a. Select one or more potential failure surfaces through the embankment. Estimate the accumulated strains that develop due to earthquake shaking using either Newmark-type analyses (Section 7.5.4) or numerical modeling (Section 7.5.5). If numerical modeling is used to estimate accumulated strains, the model output will include shear strains. If a Newmark-type analysis is used to estimate accumulated strains, the analysis will compute displacements. To convert displacements to shear strains, the thickness of the loose zone must be estimated, and the strains should be assumed to be uniform across the full thickness of the zone. In other words, the accumulated shear strain will equal the displacement divided by the thickness of the zone. (A Newmark-type analysis can be used instead of numerical modeling only for cases in which the loose zone is relatively thin compared to the overall failure mass. CPT data are probably the best way of delineating the thickness of the loose zone. Another way to delineate the thickness of the loose zone, so that shear strain can be computed from displacement, is to identify the range of potential failure surfaces for which the safety factor is within perhaps 10 percent of the safety factor of the most critical failure surface. The thickness of the range of failure surfaces can be taken as the thickness of the loose zone.

Commentary: A design earthquake motion (time history of acceleration) and dynamic soil properties (modulus and damping) are required for performing the deformation analysis required for this step.

- b. Perform a series of tests on undisturbed specimens consolidated anisotropically to in-situ stresses. First apply cyclic stresses to each specimen, and measure the accumulated strains. Then, without allowing for dissipation of the pore pressures generated by the cyclic loading, apply monotonic loading to each specimen to measure the peak strength. Perform tests at various cyclic stresses to bracket the accumulated strains indicated by the deformation analysis. The cyclic loading portion of the test should be load-controlled, and the monotonic loading portion of the test should be strain-controlled.
- c. Plot the value of peak undrained strength under monotonic loading versus the accumulated strain during loading. There should be a trend of constant monotonic peak strength for small accumulated strains and then decreasing monotonic strength for higher accumulated strains. (In the example in Castro (2003), post-earthquake strength was plotted against maximum cyclic strain instead of accumulated strain, but the concept is the same. The monotonic strength began to decrease for cyclic shear strains exceeding about 7.5 percent.)
- d. Select the post-earthquake strength as the value of monotonic strength that corresponds to the estimated accumulated shear strain from the de-

formation analysis. For clay-like materials, 80 to 100 percent of the peak-undrained strength should be used, as discussed in [Section 7.4.4.3](#).

3. Measure the effect of cyclic loading on post-earthquake strength – This approach involves performing cyclic undrained shear strength testing on undisturbed samples of the clay-like material, which are consolidated anisotropically to stresses that model the more critical in-situ conditions (i.e., higher anisotropic stress ratio for materials along the critical potential failure zone). The samples should be cyclically loaded for a conservative number (not less than 20) of cycles, while bracketing a conservative range of cyclic stress or *CSR* based on the design earthquake. (Cyclic stress or *CSR* for the design earthquake can be obtained from 1D or 2D site response analyses, as described in [Section 7.4.2.2.1](#), Method 1.) The samples should then be subject to undrained monotonic loading to measure the range in post-cycling S_u for the range of *CSR*.

The intent is to test clay-like samples at the higher end of the in-situ anisotropic stress ratio, to a conservative number of cycles (not less than 20 cycles) of loading and a conservative range of *CSR*, not to obtain a unique relationship between cyclic loading and S_u , but only to bracket a post-earthquake S_u (often higher than S_{us}) that can be applied in post-earthquake limit equilibrium analyses. This approach might be helpful in instances where undrained triaxial or direct simple-shear monotonic tests indicate a shear strain at peak strength somewhat less than 5 percent, but the post-peak drop-off in shearing resistance is not dramatic or particularly significant. It may also be helpful when such testing indicates a shear strain at peak strength greater than 5 percent, but the post-peak behavior and/or the perceived sensitivity of the clay-like material warrants more direct evaluation of the undrained strength behavior following cyclic loading.

For material that is clay-like, or that borders between sand-like and clay-like behavior, laboratory testing of undisturbed samples of the site-specific materials, as described above, should be considered. The laboratory testing might be monotonic testing to obtain just S_{up} and strain to S_{up} , or (for critical structures) cyclic loading followed by monotonic testing to obtain the relationship between seismically-induced shear strain and post-earthquake strength. If quality undisturbed samples of site-specific materials can not practically be obtained, then testing of carefully reconstituted samples of the site-specific materials should be considered. However, data from reconstituted samples should only be used if they can be compared to data from at least some undisturbed samples or a thorough base of in-situ and laboratory test data, to confirm that the reconstituted samples are representative of and/or bracket in-situ conditions.

For proposed new facilities, where material for testing is not available, undisturbed or carefully reconstituted samples of similar materials from other facilities can be used. Once a significant base of testing of fine coal refuse is built up, then it may be possible to estimate strength reduction based on correlations with previous testing. Provisions should be made to confirm soil properties of proposed facilities by performing testing as the facility is constructed.

7.4.3.2.3 Laboratory Testing of Sand-like Material to Measure S_{us}

In loose sand-like material, if the earthquake shaking triggers strength loss, then the post-earthquake strength will be equal to the undrained steady state (residual) strengths S_{us} . Estimates of S_{us} for sand-like material should first be made based on correlations with SPT and/or CPT data, as discussed in [Section 7.4.3.1](#). If desired, laboratory testing to measure S_{us} can also be performed. Laboratory testing, while complex, often results in less conservative estimates of S_{us} than the SPT and CPT correlations. If laboratory testing to measure S_{us} is planned, the designer should make the parties responsible for obtaining, transporting, and testing the samples fully aware of the methods to be followed. For example, since S_{us} is highly sensitive to void ratio, high quality undisturbed samples are required and changes in void ratio must be tracked during material sampling, trans-

portation, and testing. Failure to follow the testing guidance may bring laboratory measured values of S_{us} into question. The designer should consider discussing the approach and methods with MSHA prior to initiating sampling and testing.

The discussion that follows is based primarily on Poulos, Castro, and France (1985), which should be consulted for further details. In addition, Castro, Seed, Keller, and Seed (1992) discuss application of this laboratory testing method to the 1971 slide at the Lower San Fernando Dam. Additional information is provided in [Appendices 7A, 7B, and 7C](#) of this Manual.

At this time, an upper bound is recommended for the values of undrained steady state (residual) strength S_{us} obtained from laboratory testing of sand-like material. That upper bound is an envelope based on the median $N_{1,60}$ value of the loose layer being tested, as indicated in [Table 7.4](#). The purpose of the upper bound is to make sure that unreasonably high values of S_{us} based on laboratory testing of sand-like material are not proposed.

TABLE 7.4 UPPER-BOUND VALUES OF S_{US} FOR CORRESPONDING VALUES OF $N_{1,60}$

$N_{1,60}$	Maximum Allowable Value of S_{us} Based on Laboratory Testing
0	200 psf
5	500 psf
10	1100 psf
14	1700 psf

Some basic concepts associated with laboratory testing for measuring S_{us} of sand-like material are:

1. The undrained steady state (residual) strength S_{us} is equal to the undrained strength at high strains, after the initial structure or fabric of the material has been fully remolded.
2. S_{us} is very sensitive to void ratio and to minor changes in grain-size distribution. As discussed in [Section 7.4.1](#), deposits of sand-like material have inherent variations in both. Therefore, multiple samples from the same layer or zone are expected to have varying values of S_{us} .
3. Strain-controlled, undrained triaxial compression tests with pore-pressure measurement are typically used. Experience has shown that isotropic and anisotropic consolidation in the triaxial cell yield the same values of S_{us} . Figure 9 in Castro et al., (1992) provides a good example. Isotropic consolidation is commonly used for simplicity.
4. At strains beyond about 20 percent in the triaxial test, non-uniformities in specimen stress and strain become significant.
5. S_{us} is obtained from the triaxial test, as shown in the following. Note that these equations are derived from the Mohr-Coulomb failure envelope in [Appendix 7A](#).

$$q_s = (\sigma_{1s} - \sigma_{3s})/2, \text{ where } q_s \text{ is one-half the principal stress difference at steady state}$$

$$\sin \phi'_s = q_s / (\sigma'_{3s} + q_s), \text{ where } \phi'_s \text{ is the effective stress friction angle at steady state}$$

$$S_{us} = q_s \cos \phi'_s$$

6. For different samples of a given material (all with exactly the same grain-size distribution), S_{us} is a function only of void ratio. The relationship between void ratio and

S_{us} for a given soil, with S_{us} plotted on a log scale, is referred to as the steady-state line (Figure 7.10).

7. Since S_{us} and σ'_{3s} are related by ϕ'_s (Appendix 7A), the steady-state line can be plotted as either void ratio versus S_{us} or void ratio versus σ'_{3s} . Plotting void ratio versus σ'_{3s} makes it possible to plot the state of the sample before and after consolidation in the triaxial cell, as well as at steady state.
8. It has been shown experimentally that similar materials with the same grain shape and mineralogy, but slightly different grain-size distributions, will have steady-state lines that are parallel but not coincident. Examples are provided in Figures 3, 4, and 5 of Poulos, Castro, and France (1985).
9. High quality undisturbed samples are used to measure S_{us} of in-situ material. Because of unavoidable densification that occurs during sampling, handling, and especially during consolidation in the triaxial cell, S_{us} measured in the laboratory will be higher than the in-situ S_{us} . Correcting the value of S_{us} measured in the laboratory back to the in-situ S_{us} for a given sample requires two things. First, careful measurements must be made during sampling, handling, and testing to measure the total change in void ratio from the in-situ condition to the laboratory-consolidated condition. Second, the slope of the steady-state line must be measured.

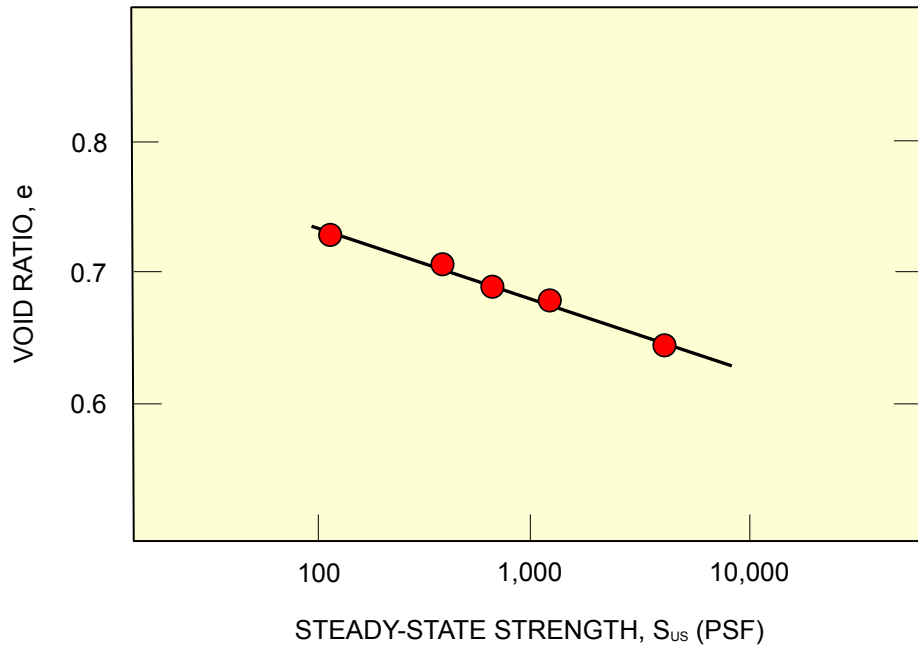

FIGURE 7.10 STEADY-STATE LINE

The basic procedural steps in a steady-state (residual) strength laboratory testing program for sand-like material are provided in the following list (for each zone of interest). Detailed procedures are presented in Appendix 7B.

1. Identify the zone of loose material based on SPT, CPT, and/or other desired field methods. Obtain enough disturbed or undisturbed samples from which a batch mix can be created that will contain enough soil for at least 5 tests to measure the slope of the steady-state line. Obtain enough high quality undisturbed samples to perform at least 8 tests on undisturbed samples from each zone of interest to measure the in-situ S_{us} . A detailed sampling procedure that has been used with fixed-piston sampling to record sample densification during sampling is provided in Appendix 7C.

2. Perform grain-size, hydrometer, specific-gravity, and (if the material has any plasticity) Atterberg-limits tests on material from the batch mix. Also perform grain-size tests on the trimmings from all undisturbed samples used to measure the in-situ S_{us} .
3. To measure the slope of the steady-state line, prepare at least 5 very loose uniform specimens from the batch mix for triaxial testing. Moist tamping in 10 layers has worked well for 3-inch-diameter by 7-inch-tall specimens. Isotropically consolidate the specimens to varying consolidation pressures such that a range of final void ratios is obtained. Carefully measure the volume of the sample in the triaxial cell after saturation but before beginning consolidation. This is typically done by applying a small vacuum to the sample so that it will maintain its shape with no cell pressure applied. After measuring the sample volume, carefully keep track of all volume change during consolidation. Shear the samples in undrained strain-controlled compression, and measure S_{us} at high strains. (See testing Note 2 below for how to identify whether S_{us} has been reached.) After the test, oven dry the entire tested sample to measure its water content. Using the water content and the specific gravity of the material, compute the void ratio during shear. Then plot the void ratio during shear versus S_{us} for each test. All the tests should plot close to a straight-line fit of the data (Figure 7.10). This is the steady-state line for the batch mix.
4. Set up, saturate, and consolidate each undisturbed sample. Measure the sample volume before consolidation and volume changes during consolidation, as discussed in the previous step. Shear each undisturbed sample in undrained, strain-controlled compression and measure S_{us} at high strains. After the test, oven dry the entire tested sample to measure its water content and dry weight. Alternatively, measure the entire wet weight, then use half the sample for water content measurement and half the sample for grain-size and/or specific-gravity testing. For fine coal refuse, a specific gravity measurement must be performed for each undisturbed test sample. Using the water content, the dry weight, and the specific gravity of the material compute the void ratio of the sample during undrained shear (Appendix 7B). The measured value of S_{us} corresponds to the void ratio during undrained shear in the triaxial cell. To estimate the in-situ value of S_{us} for that sample, first plot the result of the test on a diagram of S_{us} versus void ratio. Then draw a line upward and to the left from that data point, parallel to the steady-state line measured for the batch mix. Where the line drawn reaches the in-situ void ratio, select the value of in-situ S_{us} (Figure 7.11). Refer to Appendix 7B for detailed procedures for measuring the as-tested and in-situ void ratios of each sample.
5. The eight or more tests on undisturbed samples will result in a range of estimated in-situ values of S_{us} . Select a design value of S_{us} that is lower than two-thirds of the estimated in-situ values and higher than one third of the values. The appropriate total number of tests that should be performed for each zone depends primarily on the variability of that zone. An example is shown in Figure 7.12. As shown in the figure, one should not expect the as-tested S_{us} values from the undisturbed samples to plot on a straight line of void ratio versus $\log S_{us}$, because slight variability in grain-size distribution from sample to sample may result in significant variability in the vertical position, but not the slope of the correlation of S_{us} versus void ratio.

Some notes on testing include the following:

1. Accuracy in measuring void ratio is critical to proper measurement of S_{us} . Appendices 7B and 7C discuss the required precision of various measurements in the field and laboratory. A given error in void ratio will result in a higher error in S_{us} for mate-

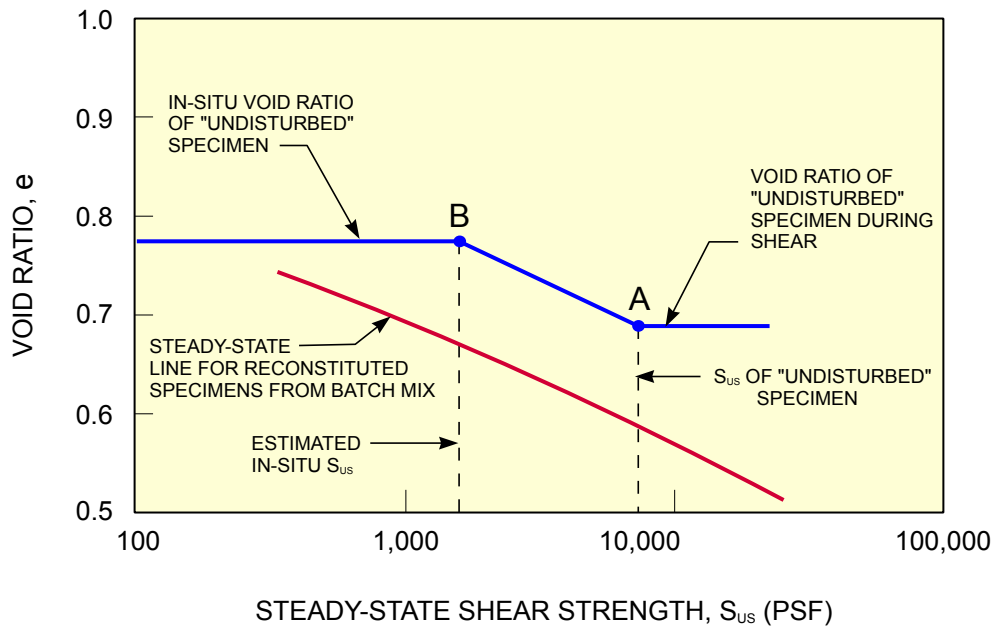

FIGURE 7.11 METHOD FOR CORRECTING LABORATORY S_{us} TO IN-SITU S_{us}

rials with relatively flat steady-state lines. In other words, materials with low slopes of the steady-state line (low values of $\Delta e / \Delta \log S_{us}$), are more sensitive to errors in the measurement of void ratio.

The range of slopes of steady-state lines ($\Delta e / \Delta \log S_{us}$) for coal refuse reported for seven sites in West Virginia and one site in Kentucky was 0.090 to 0.140 (personal communication, GEI, 2007). For the flattest slope of 0.090 (the most sensitive case), errors in void ratio measurement would lead to errors in S_{us} , as shown in Table 7.5. As discussed in Appendix 7B, void ratios at the various steps of sampling and testing should be computed to the nearest 0.001. The goal is that the computed in-situ and as-tested void ratios should be correct to within 0.010. The resulting values of S_{us} should then be correct to within 30 percent, as indicated in Table 7.5.

- When looking at a stress-strain curve to identify whether the steady state has been reached, curves for contractive samples are more definitive than curves for dilative samples. Contractive samples will typically exhibit peak strength at small strains followed by a drop-off in strength and a flattening out at the steady state within the strain limits of the triaxial test. Dilative samples, on the other hand, typically show a gradually increasing strength and may not reach steady state within the strain limits of the test. Also, dilative samples are more likely to develop failure planes during shear, meaning that steady state is reached only within the thin failure zone where the void ratio is unknown. Therefore, contractive samples are preferred.

For an undisturbed sample with a given void ratio, consolidating the sample to a higher effective confining stress before undrained shear is likely to make the sample more contractive during undrained shear, as explained further in the commentary that follows. Contractive samples tend to have stress-strain curves that are more definitive for interpretation of S_{us} , as explained in the previous paragraph. Therefore, it is often good practice to consolidate the sample to a high confining pressure before undrained shear. The disadvantage is that consolidating the sample to a high confining pressure also decreases the void ratio of the sample in the test and requires a bigger correction to obtain the in-situ value of S_{us} .

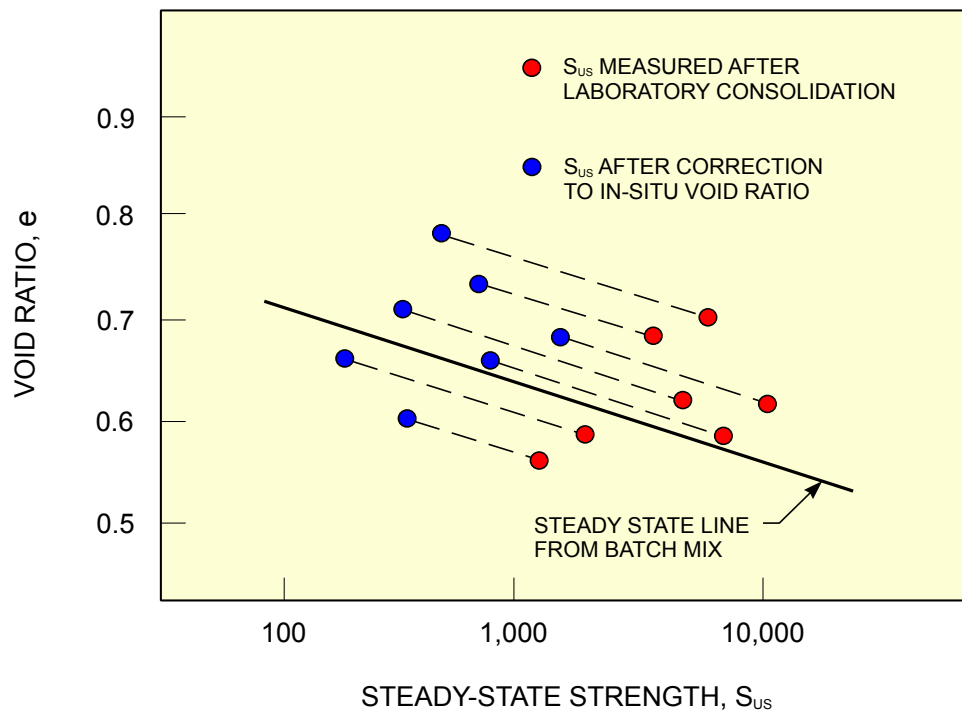
 FIGURE 7.12 INTERPRETATION OF LABORATORY S_{us} TESTING

It is not necessary to consolidate the sample to stresses that model in situ conditions. This is because the steady-state strength is the strength at high strains and is not affected by stress history. Therefore, isotropic consolidation is normally used.

Commentary: Consolidated samples that plot well to the right of the steady-state line will be contractive, as shown in Figure 6 of Poulos et al. (1985). Experience with laboratory testing tells us that the $e - \log \sigma'_3$ consolidation curve is usually slightly flatter than the steady-state line (plotted as e versus $\log \sigma'_3$ per item 7 on page 7-46). Therefore, increasing the consolidation stress tends to move the sample further to the right compared to the steady-state line, and the sample tends to become more contractive.

At the steady state, both the principal stress difference and σ'_3 should be constant with strain.

 TABLE 7.5 ERROR IN VOID RATIO AND CORRESPONDING PERCENT ERROR IN S_{us}

Error in void ratio (Δe)	$\Delta \log S_{us}^{(1)}$	$S_{us}(\text{measured})/S_{us}(\text{actual})^{(2)}$	Error in S_{us} (%)
0.005	0.0555	1.14	14
0.010	0.1111	1.29	29
-0.005	-0.0555	0.88	12
-0.010	-0.1111	0.77	23

Note: 1. $\Delta \log S_{us} = \Delta e / 0.090 = [\log S_{us}(\text{measured})] - [\log S_{us}(\text{actual})] = \log [S_{us}(\text{measured}) / S_{us}(\text{actual})]$

2. $S_{us}(\text{measured}) / S_{us}(\text{actual}) = 10^{(\Delta \log S_{us})}$

3. It is helpful to plot the compression curves ($e - \log \sigma'_3$) along with the values at steady state. Especially for the samples tested from the batch mix to measure the steady-state line, these plots will help determine what consolidation stresses are needed to achieve contractive samples at desired void ratios. (Figure 7.13)
4. Published data for coal refuse, based on laboratory testing as described above, include: (1) a reported range of 0.06 to 0.27 for S_{us}/σ'_v and (2) a reported slope of the steady-state line $\Delta e/\Delta \log S_{us}$ in the range of 0.11 to 0.13 based on laboratory testing of 34 undisturbed samples (PI in the range of 0 to 12) of fine coal refuse from five West Virginia sites (Genes et al., 2000). Also, reported slopes of the steady-state line $\Delta e/\Delta \log S_{us}$ for one site in West Virginia and one site in Kentucky were found to be 0.09 and 0.14 (GEI, 2007).

Because the preceding parameters are based on limited data and a wide range of ratios, the data should be used carefully. Also, as discussed in Section 7.4.3.1, using the ratios of S_{us}/σ'_v for confining pressures significantly higher than the confining pressures from the actual samples may be unconservative. However, if values of S_{us} are measured using laboratory testing of site-specific materials or comparable deposits at comparable confining pressures, then the site-specific ratios may be valuable for adjusting the measured S_{us} values for other portions of the embankment, or for future construction stages (Genes et al., 2000).

Over time, if a database of strength ratios for fine coal refuse is developed, it should become possible to use these ratios with more confidence.

Estimation of strengths using strength ratios requires an estimate of the consolidation pressure. One should not make the assumption a priori that the soils are normally consolidated without obtaining confirming data and monitoring. In areas where fine coal refuse will serve as the foundation for embankment construction, the design plan should include provisions for monitoring pore pressures and, if significant upstream construction is planned, controlling the rate of construction to mitigate excess pore pressure development and/or reducing the likelihood that significant zones of fine refuse will be under consolidated as construction proceeds. When evaluating existing embankments, piezometer data should be obtained to allow estimation of effective consolidation stresses. Also, pore-pressure-dissipation tests performed with the piezocone at various depths are an effective

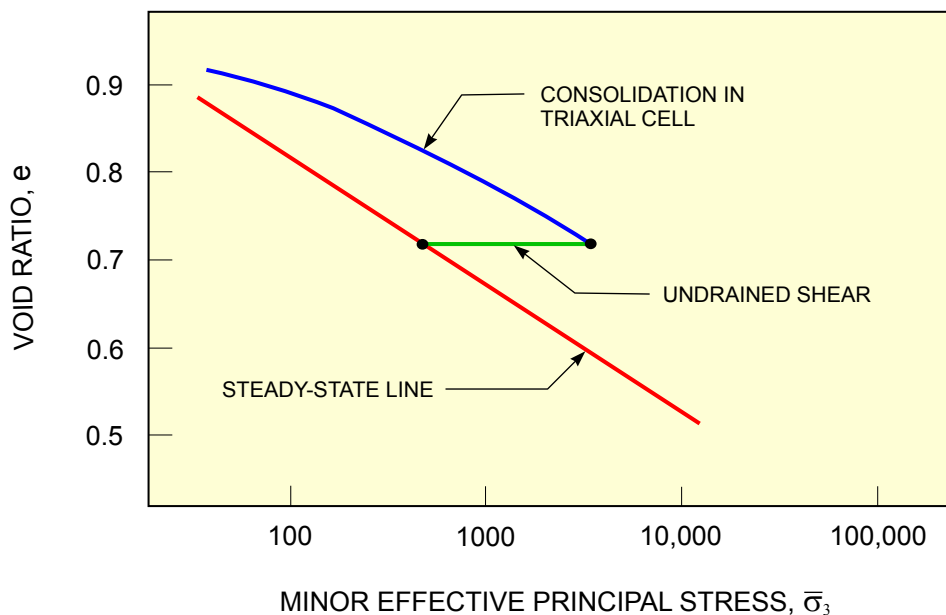

FIGURE 7.13 CONSOLIDATION CURVE AND STEADY-STATE LINE

way of obtaining the pore-pressure profile at a given location. Consolidation tests on undisturbed samples of clayey layers can also be used to determine the current consolidation stresses on the clayey layer and adjacent more sandy layers.

7.4.3.3 Field testing to Measure S_{us} of Soft Clay-Like Material

Field vane-shear testing can be used to estimate S_{us} of clay-like material. For the field vane measurements to be valid, they must be performed to high enough strains to reach S_{us} and must be performed quickly to be confident that the material is being sheared undrained. Recommended vane shear testing procedures are provided in Chapter 6, [Section 6.4.3.8](#). It is a good idea to pair field vane-shear tests with CPTs, to confirm that the field vane is being performed in a layer of clay-like material.

CPT sleeve friction measurements can also be used for estimating S_{us} of clay-like material (Lunne et al., 1997), although comparison field vane tests are recommended because the CPT sleeve friction is less reliable in sensitive clays. CPTs should be performed with pore-pressure measurements to confirm that the pore-pressure response indicates undrained shear. Lack of elevated pore-pressure response may indicate that the material is behaving as drained rather than undrained.

Commentary: For most clay-like materials the post-earthquake strength will be higher than S_{us} . Therefore, using S_{us} as an estimate of post-earthquake strength may be overly conservative. Laboratory methods of estimating post-earthquake strength of clays, as discussed in [Section 7.4.3.2.2](#), may provide less conservative estimates of post-earthquake strength.

As a lower bound, clay-like material with a liquidity index of less than 1.0 can be considered to have a post-earthquake strength of $0.04 \sigma'_{v,}$. If the liquidity index is greater than or equal to one, a lower bound post-earthquake strength of 20 psf, but no higher than $0.04 \sigma'_{v,}$ may be used. These values are guidance based on the judgment of the authors. Clay-like materials with a liquidity index less than 1.0 are unlikely to lose strength all the way to S_{us} due to earthquake shaking. A reduction in undrained strength for these materials from a pre-earthquake peak strength of $0.2 \sigma'_{v,}$ (a value within the representative range for natural clays) to a post-earthquake strength of $0.04 \sigma'_{v,}$ is considered conservative. Clay-like material with a liquidity index of 1.0 or higher may act like a “quick” clay with a very low remolded or post-earthquake strength. Therefore, a lower bound of just 20 psf, but no higher than $0.04 \sigma'_{v,}$ is considered appropriate.

7.4.4 Analysis Steps

Engineers use various methods for evaluating triggering and post-earthquake strength. Engineers also perform these evaluations and the related limit-equilibrium, slope-stability analyses in varying sequences. The following steps represent a generalized approach that can be adjusted for individual projects. Reference should be made to the flow chart in [Figures 7.1a, 7.1b and 7.1c](#).

7.4.4.1 Step 1 - Define Embankment Geometry

Define the geometry of the embankment and of the material zones within the embankment. Identify zones of clay-like versus sand-like materials.

7.4.4.2 Step 2 - Screen for Potential Strength Loss

Review the subsurface conditions at the embankment to evaluate whether any zones have the potential for strength loss due to earthquake shaking.

7.4.4.2.1 Sand-Like Material

For this initial screening step, saturated to nearly-saturated, sand-like materials with $N_{1,60}$ values less than 15, or q_{t1} values less than 75 tsf, should be considered potentially susceptible to strength loss.

Commentary: The screening criteria that sand-like materials with $N_{1,60}$ values greater than 15 or q_{t1} values greater than 75 tsf are not susceptible to strength loss are based on case-history data from large earthquakes indicating that flow slides have only occurred where $N_{1,60}$ values were 13 or lower (Seed and Harder, 1990; Castro, 1995; Wride et al., 1999) and q_{c1} values were less than 65 tsf (Olson and Stark, 2002). Olson and Stark (2003) present curves showing dilative versus contractive behavior for sands. The boundary for dilative versus contractive in terms of $N_{1,60}$ values varies from 10 to 15. The boundary in terms of q_{c1} values varies from 65 to 85. Also, Seed (1979) presents data showing that sands with relative densities higher than about 50 percent or N_1 values higher than about 15 have limited strain potential and therefore may experience cyclic mobility but not strength loss, even though pore pressures may have reached 100 percent.

Many experts agree that a fines correction might be reasonable in this screening analysis for sand-like material. That is, a silty sand may be less likely to be contractive than a clean sand with the same N -value. However, the data to support this are sparse and vague. Therefore, a fines correction should not be applied here unless additional data is published in the future that can justify it.

It is interesting to note that the curves presented in Youd et al. (2001) indicate that “liquefaction” may occur during large earthquakes in sand-like material having $N_{1,60}$ values as high as 30, and q_{c1N} values as high as 150. This is because, in Youd et al. (2001), “liquefaction” refers to increases in pore pressure but not necessarily to strength loss. As stated in the introduction to Youd et al. (2001): “In moderately dense to dense materials, liquefaction leads to transient softening and increased cyclic shear strains, but a tendency to dilate during shear inhibits major strength loss and large ground deformations.” (The term “increased cyclic shear strains” is referred to herein as cyclic mobility.) In other words, moderately dense to dense sand-like materials ($N_{1,60}$ values higher than 15 or q_{t1} values higher than 75 tsf) may experience high excess pore pressures and cyclic mobility, but they will not experience strength loss.

The criterion that sand-like materials with $N_{1,60}$ values greater than 15, or q_{t1} values greater than 75 tsf, be considered not susceptible to strength loss is a conservative criterion. Many materials with $N_{1,60}$ values less than 15, or q_{t1} values less than 75 tsf, will be dilative and not susceptible to strength loss. Therefore, if almost all $N_{1,60}$ values exceed 13 and the mean $N_{1,60}$ value exceeds 15 within a zone, or almost all q_{t1} values exceed 65 tsf and the mean q_{t1} value exceeds 75 tsf within a zone, then the zone can be considered not susceptible to strength loss.

Conservative criteria and conservative engineering judgments are appropriate and intended at this step for three reasons: (1) little if any of the data supporting these criteria are based on coal refuse materials (although, considering that coal refuse particles are more compressible than natural soil particles, one might expect these criteria to be even more conservative, because the compressibility of the coal refuse may mean that SPT and CPT values are lower for coal refuse than for natural soils at the same void ratio), (2) there is some uncertainty in the overburden corrections used to convert measured field values to $N_{1,60}$ and q_{t1} values, and (3) no further analysis is recommended for materials that satisfy these criteria.

Thorough site-specific field and laboratory testing should ultimately yield data other than $N_{1,60}$ and q_{t1} to better evaluate whether sand-like materials at a site are or are not susceptible to strength loss. If in-situ and laboratory test data are available during the initial screening phase, it should also be used in classifying sand-like zones as susceptible or not susceptible to strength loss.

7.4.4.2.2 Clay-Like Material

For this initial screening step, clay-like material may be screened for zones with potential for significant strength loss based on CPT data, as shown in Figure 7.14 (Robertson, 2008). This figure is a slightly more conservative version of a similar figure presented in Robertson and Wride (1998). In this figure, Q is equivalent to q_{c1N} and F is the friction ratio. Computation of both Q and F is discussed in Youd et al. (2001). CPT data in Zone B indicate clay-like material for which significant strength loss is unlikely. CPT data in Zone C indicate potentially highly sensitive clay-like material for which significant strength loss can occur (Zones A1 and A2 indicate sand-like material). If CPT data are not avail-

able, then SPT data can be used along with Atterberg limits to confirm that the material is clay-like. $N > 6$ corresponds to Zone B and $N < 6$ corresponds to zone C. For this screening step, the N -values of the clay-like material should be corrected for hammer efficiency per Youd et al. (2001), but should not be corrected for overburden pressure. Overburden pressure corrections are applicable only to sand-like material, not clay-like material. Undrained strength data, if available, can also be used. Peak undrained strength of 1500 psf or higher corresponds to Zone B, and peak undrained strength less than 1,500 psf corresponds to zone C.

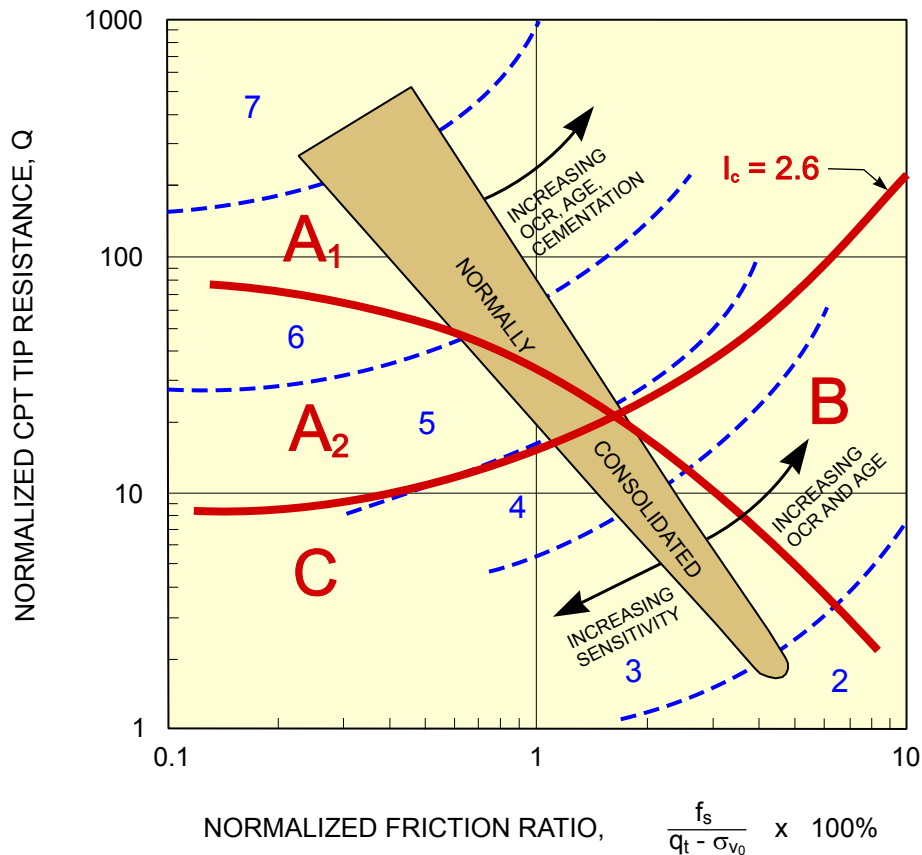

- NOTE: 1. VALUES OF Q AND F ARE COMPUTED FROM CPT DATA AT THE DEPTHS OF INTEREST, AS DESCRIBED IN YOU D ET AL. (2001).
2. CPT DATA THAT PLOT IN ZONES A₁ AND A₂ INDICATE MATERIAL THAT IS NOT CONSIDERED CLAY-LIKE, SO THIS SCREENING METHOD IS NOT APPLICABLE.
3. CPT DATA THAT PLOT IN ZONE B INDICATE CLAY-LIKE MATERIAL THAT IS NOT SUSCEPTIBLE TO STRENGTH LOSS.
4. CPT DATA THAT PLOT IN ZONE C INDICATE CLAY-LIKE MATERIAL THAT MAY BE SUSCEPTIBLE TO STRENGTH LOSS.
5. NUMBERED ZONES SEPARATED BY DASHED BLUE LINES ARE FOR REFERENCE ONLY AND ARE A GUIDE TO SOIL TYPES, AS DESCRIBED IN YOU D ET AL. (2001). FOR EXAMPLE, DATA IN ZONE 3 INDICATE SILTY CLAY TO CLAY WHILE DATA IN ZONE 6 INDICATE CLEAN SAND TO SILTY SAND. THE LINE SEPARATING SAND-LIKE FROM CLAY-LIKE MATERIAL CORRESPONDS TO A SOIL BEHAVIOR TYPE INDEX (I_c) OF 2.6, AS ALSO DESCRIBED IN YOU D ET AL. (2001).

(ADAPTED FROM ROBERTSON, 2008; © 2008 NRC CANADA OR ITS LICENSORS; REPRODUCED WITH PERMISSION.)

FIGURE 7.14 USE OF CPT DATA TO SCREEN CLAY-LIKE MATERIAL

Commentary: These screening criteria for clay-like material are recommended guidance. No generally accepted screening criteria for susceptibility to strength loss were found in the literature. Selection of these criteria is based on the authors' judgment and experience, and considering published data from sites where liquefaction (strength loss or excess pore pressure) was observed in soils with significant fines content.

In applying these criteria, CPT data are considered the most reliable, laboratory strength data the next most reliable, and SPT data the least reliable.

7.4.4.2.3 Screening Results

If no zones within the embankment or foundation are susceptible to strength loss, then the seismic stability of the embankment is acceptable (assuming, of course, that the static stability has been analyzed and is acceptable, including cases where undrained strengths are considered). No further analyses of seismic stability are needed. The next step is to evaluate seismic deformations.

If one or more zones within the embankment or foundation are susceptible to strength loss, then further analyses should be performed as discussed in Step 3, which follows.

7.4.4.3 Step 3 - Define Post-Earthquake Strengths for Limit Equilibrium Stability Analyses

Stability analyses are typically performed using 2D limit-equilibrium, slope-stability software for one or more potentially critical cross sections of the embankment. The stability analyses should be static analyses using post-earthquake strengths. Analyses should be performed for both potential upstream and potential downstream failures.

Upstream failures may or may not pose a risk of uncontrolled release, depending on whether the location of the critical surface leaves adequate freeboard and crest width in place. Guidelines for deciding whether potential upstream failures pose a safety hazard are discussed in [Sections 6.6.4.1 and 6.6.4.3](#).

Values of post-earthquake strength for various zones of the embankment should be selected as discussed in the following:

- Dense sand-like materials ($N_{1,60} > 15$ and $q_{t1} > 75$ tsf) such as compacted coarse refuse and dense sand-like natural soils tend to be dilative when they are sheared. That is, the undrained strength tends to be higher than the drained strength. Also, these materials do not experience strength loss due to earthquake shaking. For post-earthquake stability analysis, one cannot be certain whether the material will act as if it is drained or undrained, and the negative pore pressures required to mobilize a higher strength may not develop because they cause cavitation. Therefore, it is reasonable and conservative to use the drained strength for these materials, as discussed in Chapter 6.
- Stiff clay-like materials (SPT $N > 6$ and CPT data in Zone B) tend to have high shear strain up to the peak undrained strength and limited drop-off in shearing resistance after the peak, so they should not experience significant strength loss due to earthquake shaking. Unlike dense sand-like materials, stiff clay-like materials should act as undrained during the most critical earthquake and post-earthquake period. For these materials, 80 to 100 percent of the peak undrained strength should be used.

Commentary: Available data indicate that the cyclic stresses and strains caused by earthquakes are unlikely to cause significant strength reduction in stiff clays. However, some practitioners have commonly used 80 percent of the peak undrained strength for clays that are subject to significant seismic loading, presumably to account for possible strength degradation and other factors. Therefore, although it is perhaps overly conservative, the 80-percent value is recommended in areas of moderate to high seismic hazard potential. Use of 100 percent of the peak undrained strength is reasonable in areas of low seismic hazard potential and when applying a factor of safety of 1.5 in initial post-earthquake stability evaluations to classify the structure and foundation ([Figure 7.1a](#), Boxes 5 and 6).

- For loose saturated sand-like material, as in most fine coal refuse impoundments, strength should be selected based on the results of triggering analyses, and S_{us} estimates should be made in accordance with the previous sections of this chapter. If triggering of strength loss is assumed or computed to occur, use S_{us} . If triggering is assumed or computed to not occur, use the peak undrained strength, but no higher than the drained strength. The S_{up} values for sand-like materials can be obtained from published data such as Castro (2003) and Olson and Stark (2003). Alternatively, the S_{up} values can be obtained from the testing on remolded samples performed as part of the testing program described in Section 7.4.3.2.3. Tests on remolded samples with values of steady-state strength and confining pressure similar to in-situ samples can be considered representative of in-situ conditions.

Drained strengths for these materials can be used if they are clearly determined to be unsaturated (saturation ratio less than 80 percent), and it can be demonstrated that they will remain unsaturated. (When the degree of saturation is higher than 80 percent, strength loss is still possible for loose, sand-like material.) Materials above the phreatic surface should not necessarily be assumed to be unsaturated. Materials above the phreatic surface may be saturated or close to saturated, particularly if the water level was previously higher than the current phreatic surface.

- For soft or sensitive clay-like material (SPT $N < 6$ or CPT data in Zone C), strength should be selected based on the results of strength-loss estimates made in accordance with Sections 7.4.2.3.1, 7.4.3.2.2, and 7.4.3.3. If triggering (significant strain during the earthquake) is assumed or computed to occur, use a value lower than S_{up} , but probably not as low as S_{us} . (If the zones of this material are relatively small and probably not significant to the seismic stability, then S_{us} can be used as the post-earthquake strength even though it is probably overly conservative. For highly sensitive clays, S_{us} may be the appropriate post-earthquake strength.) If triggering (significant strain during the earthquake) is computed to not occur, use 80 percent of S_{up} . S_{up} for clay-like material can be obtained from CPT data, field vane shear testing, or laboratory testing. S_{up} for borderline material can be obtained from CPT data (if the push is undrained based on pore-pressure response) or from laboratory testing or possibly from field vane-shear tests performed at high strain rates.

Coal refuse impoundments tend to be stratified. Variations in post-earthquake undrained strengths may be more significant than variations in drained strengths. Therefore, post-earthquake strengths should be selected conservatively. For zones of mixed coarse and fine refuse (such as the lower portion of an upstream stage), use strength properties weighted toward the properties of the overlying coarse refuse zone or the underlying fine refuse zone, based on the prevalence and extent of each zone, the index properties of each zone, and a realistic estimation of the upstream embankment cross section (based on subsurface conditions and past experience with displacement of fines during upstream construction pushouts).

Commentary: *Strain compatibility is not an issue for these stability analyses, because the strengths used all represent reasonably conservative estimates of the undrained strength that the soil might have at high strains (5 percent to 10 percent). As discussed previously, the recommended strengths are:*

- Loose sand-like material – Undrained steady-state (residual) strength. This is the lowest resistance that the material can have at any strain beyond a few percent.
- Dense sand-like material – Drained strength. The undrained stress strain curve of a dense, dilative, sand-like material increases steadily with strain with no drop-off at high strain. For these materials, the drained strength is a conservative estimate of the undrained resistance at any strain beyond a few percent.

- *Soft clay-like material* (SPT $N < 6$ or CPT data in Zone C) – Either: (1) the undrained steady state (residual) strength as a very conservative estimate of the available strength, (2) the post-earthquake peak strength estimated from cyclic tests followed by monotonic (static) tests, or (3) 80 percent of the peak-undrained strength. But option 2 or 3 can only be used if the clay-like material has a broad peak to the stress-strain curve, with no rapid drop-off in resistance after peak, which is the case for most clay-like material. So, the strength selected for use should be appropriate for a wide range of strain.
- *Stiff clay-like material* (SPT $N > 6$ and CPT data in Zone B) – 80 to 100 percent of undrained peak strength. The undrained stress-strain curve of stiff clay-like material reaches nearly its peak strength at a few percent strain and then levels off or increases slowly with strain with no drop-off at high strain. So, again, the strength used is appropriate for a wide range of strain. As discussed above, the 80-percent value is recommended in areas of moderate to high seismic-hazard potential. Use of 100 percent of the peak-undrained strength is reasonable in areas of low seismic-hazard potential, and when applying a factor of safety of 1.5 in initial post-earthquake stability evaluations to classify the structure and foundation (Figure 7.1a, Boxes 5 and 6).

7.4.4.4 Step 4 - Perform Initial Stability Analysis

First perform an initial, conservative, post-earthquake stability analysis. This initial stability analysis is performed with the assumption that the earthquake shaking is strong enough that soils potentially susceptible to strength loss do in fact experience strength loss.

Use S_{us} for sand-like material in zones of the embankment that, based on the screening analysis in Section 7.4.4.2, have low N-values and CPT values and may therefore be susceptible to strength loss. For this analysis, S_{us} for sand-like materials can be conservatively estimated from correlations with SPT and/or CPT data (Section 7.4.3.1). Also, the post-earthquake strength of clay-like material considered not susceptible to significant strength loss (Zone B on the CPT chart or $N > 6$) can be estimated as 80 to 100 percent of S_{up} , as discussed in Section 7.4.4.3. The post-earthquake strength of clays considered potentially susceptible to significant strength loss should be taken as an estimated value of S_{us} . S_{up} and S_{us} for clays can be estimated from CPT data, field vane shear data, or laboratory data (Chapter 6 and Section 7.4.3.3).

The slope stability analysis is a total-stress analysis using undrained strength, which is a function of the pre-earthquake consolidation stress. The location of the phreatic surface affects the pre-earthquake consolidation stresses and thus the undrained strength. The estimated location of the phreatic surface at the time of the earthquake should be used in the stability analysis. Elevated pore pressures caused by earthquake shaking need not be considered.

If these initial stability analyses (for various potential upstream and downstream failure surfaces) indicate a minimum safety factor of at least 1.2, then seismic stability is considered acceptable, and the next step is to perform a deformation analysis.

If the minimum safety factor is below 1.2, then the embankment geometry should be modified to make the factor of safety acceptable, or else more sophisticated (and less conservative) evaluations of post-earthquake shear strength and triggering, as subsequently discussed, may be appropriate. If the safety factors are very low, then it may be clear at this initial stage that some modification to the embankment design is needed. It is often useful to vary the assumed values of S_{us} in the zones potentially susceptible to strength loss to find the values of S_{us} that would be needed to obtain a safety factor against instability of 1.2, and then judge if the materials in question could possess such strengths before undertaking more detailed evaluations of S_{us} .

Commentary: A safety factor of 1.2 is recommended for this analysis because, even though the shear strengths selected for this analysis are fairly conservative, there may be significant uncertainties in the geometry of the embankment and the various zones within the embankment and foundation.

7.4.4.5 Optional Step 5 - Perform More Detailed Evaluation of S_{us} for Sand-Like Material

Obtain representative high quality undisturbed samples of sand-like material in zones that may experience strength loss (Section 7.4.4.2). Perform a laboratory steady-state shear strength testing program involving monotonic undrained tests on both undisturbed and reconstituted specimens (Section 7.4.3.2.3) to obtain better estimates of S_{us} .

Re-run the limit equilibrium stability analyses using the better estimates of S_{us} . If the minimum safety factor is at least 1.2, then the seismic stability of the embankment is acceptable, and seismic deformations should be evaluated next.

Commentary: The preceding discussion refers to laboratory testing to measure S_{us} for sand-like material. Performing this testing before undertaking triggering analyses should be considered, because the measured values of S_{us} might result in satisfactory seismic stability, and thus triggering would not be an issue. Also, the S_{us} testing will give information on stress-strain behavior, including strain at peak-undrained strength, which may be used in the triggering analysis. However, this step involves complex sampling and testing, and it can be deferred until after a triggering analysis is performed. This step can also be skipped entirely, especially if the post-earthquake strength of sand-like materials was not a significant factor in the initial stability analyses.

7.4.4.6 Optional Step 6 - Perform Triggering Analysis

If the minimum safety factor is still less than 1.2 after a more detailed evaluation of S_{us} , then for loose sand-like material, consider performing a triggering analysis, as discussed in Section 7.4.2, to evaluate whether the earthquake is large enough to trigger strength loss in the critical zones.

For sand-like materials, triggering analyses should only be performed if the design earthquake is relatively small. If the design earthquake produces a peak ground acceleration at the embankment site of more than 0.2g and causes a cyclic stress ratio (CSR) within the zone of interest of more than 0.15, then triggering of strength loss in sand-like material potentially susceptible to strength loss should simply be assumed.

If triggering analyses are performed for sand-like materials, the pore-pressure-based method, as discussed in Section 7.4.2.1 (Youd et al., 2001) should be performed first. If the safety factor against triggering using the pore-pressure-based method (CRR/CSR) is higher than 1.4, then triggering can be assumed to not occur. If the safety factor is less than 1.0, then triggering of strength loss should be assumed. For safety factors of between 1.0 and 1.4 calculated using the pore-pressure-based method, triggering of strength loss is possible. Either assume that triggering of strength loss will occur, or perform more rigorous triggering analyses (strain-based or stress-based methods as discussed in Section 7.4.2.3) to make a final evaluation of whether or not triggering occurs.

For clay-like material, a strain-based triggering analysis (possibly involving laboratory testing with cyclic loading followed by monotonic loading as discussed in Section 7.4.3.2.2) can be performed to evaluate whether the earthquake shaking is strong enough to trigger a decrease in S_{up} and to determine what the decrease will be.

If strength loss is not triggered in one or more of the zones that had previously been assumed to experience strength loss, then re-run the stability analysis using the appropriate, higher strength in those zones as discussed in Step 3, Section 7.4.4.3. If the safety factor is at least 1.2, then the seismic stability is acceptable, and seismic deformations should be evaluated next.

If the safety factors are still less than 1.2, then the embankment is not seismically stable. Additional investigations should be performed to better characterize the geometry and materials in the embankment or the embankment must be redesigned or modified.

7.4.5 Comments on Methods for Evaluating Triggering and Strength

All of the methods described in this chapter require special expertise, and should only be applied by geotechnical engineers with experience in seismic stability and deformation analyses.

Laboratory steady-state (residual) strength testing programs provide site-specific values of S_{us} that are often less conservative than the values obtained from empirical correlations with SPT and CPT data, but these testing programs require sophisticated undisturbed sampling and laboratory testing.

Strain-based triggering analyses require sophisticated laboratory testing and sophisticated analyses of shear strains induced by the design earthquake for evaluation of whether the earthquake shaking is strong enough to cause strength loss down to S_{us} . Thus, steady-state laboratory programs and strain-based triggering analyses are normally performed only for large embankments where the additional testing and analysis costs are relatively small compared to the cost of redesigning or modifying the embankment.

If contractive zones of material are confined by overlying layers of material with low hydraulic conductivity, then drainage of excess pore water generated by earthquake shaking can be impeded. There is some indication from centrifuge model tests that this may result in migration of pore water toward the overlying low-hydraulic-conductivity layer, with consequent redistribution of void ratio and loosening of the material near the interface with the low-hydraulic-conductivity layer. This in turn reduces the post-earthquake strength of the material near the interface. This mechanism was suggested by Whitman in the 1980s. Recent work on the subject includes Malvick et al. (2006) and Naesgaard et al. (2005). There are currently (2008) no generally accepted methods for analyzing this potential mechanism, and therefore it need not be directly considered in stability analyses at this time. A method for including the potential effects of void ratio redistribution on post-earthquake strength has been proposed by Idriss and Boulanger (2007). As discussed in [Section 7.4.3.1](#), this method can be used for sand-like material with $N_{1,60} > 15$ if one has a concern for the possibility of void-ratio redistribution (contractive zones overlain by lower-hydraulic-conductivity materials that would impede dissipation of excess pore-water pressure). In such a case drainage provisions (such as wick drains, as discussed in [Section 6.6.3.3](#)) could be incorporated. The need for such drainage provisions for dissipation of pore pressure in fine coal refuse at a slurry impoundment could be assessed based on pore-pressure monitoring during upstream construction.

Commentary: Pore-water migration and void-ratio redistribution (which may or may not actually occur outside laboratory centrifuge tests) are not considered in either laboratory testing or SPT/CPT methods for estimating post-earthquake strength. The laboratory testing relates to pre-earthquake void ratios. If there is pore-water migration, the relationship of void ratio to strength obtained from the laboratory testing would allow one to quantify the effects of a given amount of void ratio change (assuming that one day we will have methods to estimate to what extent, if any, pore-water migration takes place). SPT and CPT data also reflect pre-earthquake conditions. One cannot expect that SPT or CPT data will be able to predict whether or not, and to what extent, pore-water migration might take place, and what impact the pore-water migration might have on post-earthquake strength.

At the present time (2008), it is debatable whether pore-water migration did or did not occur for the case histories used to develop the relationships between SPT/CPT data and post-earthquake strength. For example, extensive investigations of the Lower San Fernando Dam slide indicate that the characteristics of the slide can be explained without assuming pore-water migration (Castro, Seed, Keller, and Seed, 1992).

7.5 SEISMIC DEFORMATION ANALYSES

7.5.1 General Discussion

The procedures described in Sections 7.5.2 through 7.5.6 are appropriate for sites where seismic stability has been shown to be adequate based on analyses discussed in the previous sections of this chapter. Even if the seismic stability is adequate, a dam or embankment will deform during earthquake shaking because of the development of accumulated strains along a potential sliding surface due to the superposition of seismic and static (driving) shear stresses. Two mechanisms for developing accumulated strains should be considered:

- **Yielding mechanism** – When seismic accelerations in an embankment are high enough, total shear stresses (static plus cyclic) along a potential failure surface may tend to exceed the available shear strength. The soil along the potential failure surface yields during short earthquake time increments when the total shear stress tends to exceed the available shear strength. Another way of saying this is that the soil along the potential failure surface yields during the short time increments of the earthquake when accelerations are higher than the acceleration that can be transmitted by the soil. This mechanism can occur in both sand-like and clay-like material. The resulting deformations can be evaluated using Newmark-type analyses.
- **Ratcheting mechanism** – As shown in [Figure 7.15](#), cyclic stress-strain curves are softer in loading than in unloading. When there is a static shear stress, repeated cyclic loading will result in accumulated strains (deformations) in the direction of the static shear stress, even if the available shear strength is not exceeded. These ratcheting accumulated strains (deformations) are generally significant only if cyclic mobil-

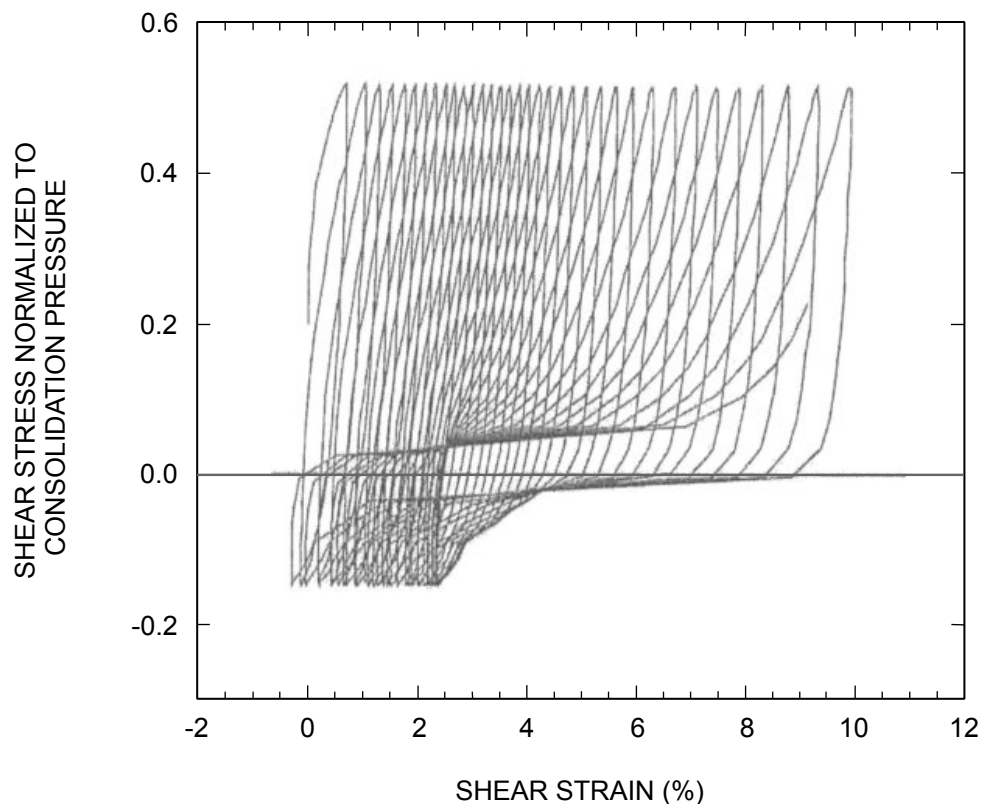

(SEED ET AL., 2003)

FIGURE 7.15 CYCLIC STRESS-STRAIN CURVE DEMONSTRATING RACHETING MECHANISM

ity occurs. If the cyclic loading involves stress reversal (i.e., the cyclic shear stress exceeds the static consolidation shear stress), and if enough cycles of loading occur that pore pressures approach 100 percent, then the cyclic stress-strain curve will develop an S-shape, and the cyclic strains will become significant. This type of cyclic stress-strain behavior is referred to as cyclic mobility. If there is no static shear stress, then cyclic mobility will not cause significant accumulated strain. Similarly, if there is a static shear stress, but cyclic mobility does not occur, then accumulated strains will generally be insignificant. To evaluate whether a material will develop cyclic mobility due to earthquake shaking, the Youd et al. (2001) procedure should be used to evaluate whether excess pore pressures will approach 100 percent. For the purpose of deformation analyses, a safety factor (CRR/CSR) of 1.0 or less should be considered to result in cyclic mobility.

For both the yielding and ratcheting mechanisms, the deformations are driven by the earthquake shaking. Therefore, the magnitude of the deformations is related to the intensity of the earthquake. This is in contrast to seismic instability, where the instability failure may be triggered by the earthquake shaking, but the instability failure is driven by the static (gravity) weight of the embankment.

Deformations may involve the embankment crest and both the upstream and downstream embankment slopes. Deformations along the upstream slope may or may not pose a risk of uncontrolled release, depending on whether the location and magnitude of the potential movement leaves adequate freeboard and crest width in place. Guidelines for deciding whether potential upstream slope movements pose a safety hazard are discussed in Sections 6.6.4.1 and 6.6.4.3. If these guidelines are met, detailed deformation analyses may not be required (i.e., if deformation screening or simplified analysis indicates acceptable performance for potential sliding masses that include the crest or provide overall dam freeboard and integrity, then detailed analyses may not be needed for other potential sliding masses that do not affect the integrity of the dam). While this point may also apply to potential movements on the downstream slope, the deformation, strain and stability of the remaining embankment should be evaluated considering both undrained and drained strength conditions and the potential for progressive failure.

Commentary: If seismic stability and deformation screening or simplified analysis demonstrate that a substantive portion of the embankment and crest would be preserved and would be sufficient to preclude a release from the impoundment (although other portions of the embankment might be compromised), then detailed deformation analysis to assess the significance of other zones that might be subject to cyclic mobility may not be warranted. This judgment should be based on the site-specific cross-section and material properties with careful consideration of: (1) the presence, extent and depth of zones of potential cyclic mobility and (2) mitigating factors that would limit large deformations or otherwise provide support for the adjoining embankment (e.g., the configuration of the upstream slope and impoundment might restrict the amount of displacement that could be expected, thus providing some remaining confinement and support to preserve a substantial portion of the foundation and embankment).

Limit-equilibrium slope stability analyses, employing post-earthquake strengths, might be useful in identifying the foundation-embankment zone most prone to significant deformation and in judging what portion of the foundation and embankment would remain to preclude a release from the impoundment. For broader dams and broader upstream embankment stages, limit-equilibrium analyses with post-earthquake strengths may be adequate to justify that sufficient embankment breadth, crest width and freeboard would remain such that detailed deformation analyses are not warranted. However, for narrower dams and narrower upstream embankment stages founded on significant zones subject to potential cyclic mobility, the initiation and progression of excessive deformation and breaching of the crest may be a concern, and detailed deformation analyses are likely to be unavoidable. The distinction between “broader” and “narrower” dams and embankments is not definitive, but

professional judgments can be supported by the margin of safety suggested by the static and seismic (post-earthquake) stability analyses, considering potential failure surfaces within portions of the embankment-foundation that are anticipated to be preserved (e.g., factors of safety much greater than the minimum recommended values of 1.5 and 1.2, respectively) and supported by a limited extent of potential failure reflected by surfaces with low factor of safety (e.g., near the recommended minimum). Generally, to justify such judgment, potential failure surfaces with a low factor of safety should be limited in extent relative to the entire embankment breadth.

7.5.2 Preliminary Screening

If the site is in a low seismic-hazard area, which is defined in Section 7.7.3.7 as an area where the National Seismic Hazard Map of the United States (Frankel et al., 2002) indicates that the PGA with a return period in 2,500 years is less than or equal to 0.10g, and if the seismically-induced, pore-pressure buildup does not approach 100 percent (which could lead to cyclic mobility), then deformations will be small enough that no further evaluation of deformations is required. As noted in Section 7.5.1, all deformation evaluations, including this preliminary screening, are applicable only if the embankment has first been determined to be seismically stable. Therefore, for preliminary screening, the following steps can be followed, as indicated in the flow chart in Figure 7.1c:

1. Is this a structure-foundation system for which no deformation analysis at all is required (e.g., structures of the type indicated in Figure 7.1a, Box 1)? If the answer is "Yes," then no seismic deformation analysis is required. If the answer is "No," then continue to Step 2.
2. If the site is in an area of low seismic hazard potential (as defined in Section 7.7.3.7), then continue to Step 3. If the site is in an area of higher seismic hazard area, then skip to Step 5.
3. In sand-like materials, evaluate the potential for pore-pressure increase using the methods discussed in Section 7.4.2.2 (Youd et al., 2001). If the safety factor against 100 percent pore-pressure increase in any zone (*CRR/CSR*) is greater than 1.0, then cyclic mobility will not develop in that zone. For clay-like materials, confirm the safety factor from the static stability analysis using post-earthquake strengths. If the safety factor is greater than 1.2, then significant deformations in zones of clay-like material are unlikely.
4. If the analyses in Step 3 do not indicate cyclic mobility in sand-like material and the analyses in Step 3 indicate high safety factors for static stability in clay-like material, and if the site is in a low-seismic-hazard-potential area, then deformations will be small enough that no further evaluation of deformations is required.

Commentary: These criteria are intended to be conservative and represent recommended guidance based on experience with deformation analyses.

5. If the criteria in Step 3 are not met, or if the site is not in an area of low seismic hazard potential, then permanent deformations should be evaluated, as described in Sections 7.5.3 through 7.5.6, which follow.

7.5.3 Pseudo-Static Procedure for Screening

A relatively simple pseudo-static procedure (Hynes-Griffin and Franklin, 1984) can be used for screening of seismically-induced deformations. This procedure is applicable only if all of the following conditions are met:

- Design earthquake of magnitude less than 8 ($M < 8$).
- No significant zones susceptible to strength loss, as determined during the seismic

stability analyses (Sections 7.4.2 or 7.4.4.2).

- Small displacements (less than 3 feet) are not significant to the performance of the dam or embankment.

For this procedure, limit-equilibrium slope-stability analyses are performed with a pseudo-static seismic coefficient of one-half the PGA determined at the base of the embankment. For clay-like material, 80 percent of the peak undrained shear strength should be used. For sand-like material, 80 percent of the peak undrained shear strength, but no higher than 80 percent of the drained strength should be used. If the factor of safety is greater than 1.0 (based upon a thorough scope of geotechnical investigation or a high confidence level in material characterizations) or greater than 1.2 (based upon a moderate geotechnical investigation or less certain material characterization), then the deformations can be assumed to be less than 3 feet.

Commentary: Hynes-Griffin and Franklin (1984) suggested that a safety factor of 1.0 is adequate for assuming deformations would be less than 3 feet. The 1.2 safety factor has been added for cases where there is limited confidence in the site characterization. The method was developed based solely on earthquake records from the 1971 San Fernando earthquake. However, it is considered acceptable to apply the method to eastern as well as western sites. This screening analysis applies to any height of embankment. The height is taken into account indirectly by the pseudo-static limit-equilibrium analysis.

7.5.4 Newmark-Type Analysis (No Cyclic Mobility)

This method of analysis addresses the yielding mechanism of strain accumulation discussed in Section 7.5.1. In these Newmark-type analyses (Newmark, 1965), deformations are analyzed by considering movements of a sliding mass over a sliding surface caused by yielding of the soil at its available strength. The basic assumption is that movement (or yielding) occurs when the sum of the static plus the seismic shear stresses along the sliding surface reaches the value of the available shear strength. Thus, the acceleration that can be transmitted to the sliding mass is limited to a value referred to as the yield acceleration.

A Newmark-type analysis is not appropriate for very large deformations because it is based on the assumption that the embankment geometry is the same before and after the earthquake.

The basic steps are as follows:

1. For a given sliding mass, perform a pseudo-static stability analysis to determine the horizontal acceleration that produces a safety factor of one. This is the yield acceleration k_y , and it has the units of gravity. Critical sliding masses may be selected by searching for the most critical mass (critical sliding surface) while varying the pseudo-static horizontal acceleration until a safety factor of one is achieved. The estimated location of the phreatic surface at the time of the earthquake should be used. Elevated pore pressures caused by earthquake shaking need not be considered. The material strengths for the pseudo-static stability analyses should be the available undrained strengths determined as indicated in Sections 7.4.1 through 7.4.3 and 7.4.4.3. In general, the following strengths should be used:
 - Loose sand-like material – Undrained peak strength S_{up} or undrained steady-state (residual) strength S_{us} depending on results of triggering analysis
 - Dense sand-like material – Peak undrained strength S_{up} but no higher than peak drained strength S_{dp}
 - Soft to medium clay-like material – 80 percent of S_{up}
 - Stiff clay-like material – 80 percent of S_{up} or 80 percent of the post-earthquake strength determined as per Section 7.4.3

Commentary: The use of 80 percent of S_{up} instead of 100 percent of S_{up} for stiff clay-like materials in Newmark deformation analyses is based on a recommendation in Makdisi and Seed (1978). The recommendation accounts for the fact that some deformation accumulates when the peak stresses exceed about 80 percent of S_{up} . The Newmark analysis assumes that there is no deformation until the selected strength is reached. The 80-percent value results in some computed deformation when stresses exceed 80 percent of peak.

2. Define a time history of average acceleration of the sliding mass $k(t)$ during the design earthquake. Values of $k(t)$ are in units of gravity. The maximum value of $k(t)$ is referred to as $k(max)$. One- or two-dimensional computer programs such as SHAKE, FLUSH, or QUAD4 can be used to compute $k(t)$ by modeling the propagation of the earthquake motion from bedrock to the zone of interest. The $k(t)$ time history is not the same as the acceleration time history output by SHAKE (or other programs) at the elevation of the base of the sliding mass. Rather, to obtain $k(t)$, one should take the time history of seismic shear stress output by the computer program at the base of the sliding mass and divide it by the total overburden pressure at that elevation (acceleration equals force/mass or stress/pressure). In this way, $k(t)$ will represent the average acceleration of the sliding mass and not the acceleration of individual layers or elements at the base of the sliding mass. Note that the total overburden pressure must not include the overburden stress caused by any free water above the ground level.

Commentary: In SHAKE, or other programs, potential yielding of the soil is ignored, so the computed accelerations, $k(t)$ can be higher than the yield acceleration. The analysis is said to be decoupled because it separates the computations of accelerations and the computations of deformations due to yielding, when in fact they occur simultaneously. However, comparisons with more rigorous coupled methods indicate that generally the uncoupled method is satisfactory. Wartman et al. (2004) conclude that uncoupled analyses are satisfactory for cases where the predominant frequency of the motion is at least 1.3 times the natural frequency of the soil mass, which is generally the case for earthquake shaking of dams and embankments.

3. During time intervals that $k(t)$ exceeds k_y , displacements are initiated. Displacements continue even after $k(t)$ becomes less than k_y , until the velocity of the mass becomes zero. Compute the total displacement of the sliding mass by double-integrating the portion of the $k(t)$ curve above and below k_y for time intervals where velocity is greater than zero (Figure 7.16).
4. If performing one-dimensional analyses at different points along the potential failure surface to compute $k(t)$, then the resulting displacements must be combined in order to estimate the displacement of the overall potential failure wedge. A method for combining the computed displacements is presented in Appendix 7D.

The deformations computed using a Newmark-type analyses are appropriate only if there is no significant softening (loss of stiffness) of the soil caused by cyclic mobility, as described in the second bullet point (ratcheting mechanism) in Section 7.5.1. This is because the Newmark-type analyses are based on the assumption that no displacements are initiated during time intervals when $k(t)$ is less than k_y , but significant displacements could occur during those time intervals if cyclic mobility and resulting accumulated strains are occurring.

Commentary: Newmark-type analyses should generally not be used if cyclic mobility is expected (i.e., if $CRR/CSR \leq 1.0$). Newmark-type analyses are based upon the assumption that there is no deformation when the sum of static plus seismic shear stresses is less than the available shear strength. But if cyclic mobility occurs, then significant deformations may occur due to the ratcheting mechanism described in Section 7.5.1

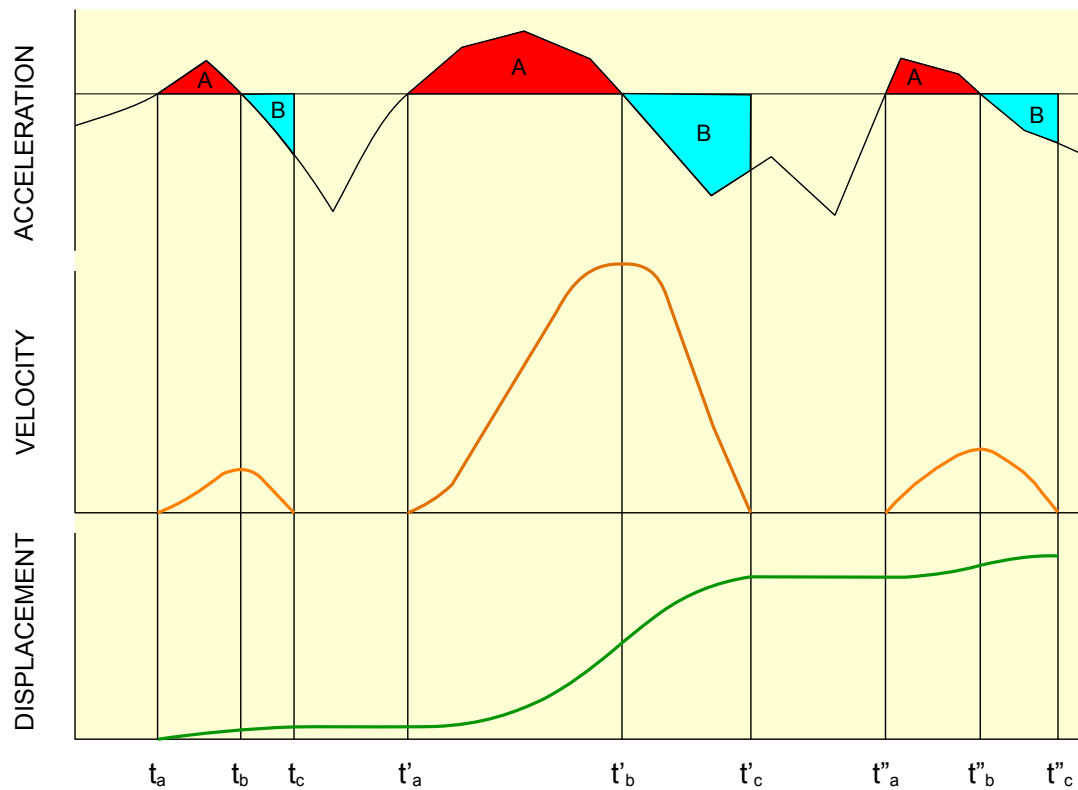

FIGURE 7.16 DOUBLE INTEGRATION TO OBTAIN DISPLACEMENT

even when the sum of the shear stresses is less than the available strength. Therefore, if cyclic mobility occurs, the Newmark-type analyses will under-predict deformations. In areas of low seismic hazard potential, the earthquake shaking may not be high enough to cause cyclic mobility. For small earthquakes, CRR/CSR may be greater than 1, such that Newmark-type analyses may be valid even for cases of upstream construction with loose sand-like material.

A simplified procedure for evaluating embankment deformations using the Newmark method was developed by Makdisi and Seed (1978). The method provides estimates of embankment deformations if the following information is known or a representative range of values can be established:

- The natural period of the embankment
- The maximum crest acceleration due to earthquake shaking
- The earthquake magnitude

The method was developed for embankments in the range of 100 to 200 feet high with a natural period ranging between 0.26 seconds and 5.22 seconds, based on several western earthquake records with magnitudes of about 6.5 to 8.25. A simplified formula for estimating the natural period of the embankment ($T = 2.6 H/V_s$ where H is the height of the embankment and V_s is the representative shear-wave velocity) is provided in Makdisi and Seed (1977). This simplified formula for the natural period is applicable to embankments with a cross section that is approximately triangular and therefore may not be applicable to non-trapezoidal coal refuse embankments. For embankment configurations that deviate from a triangular cross section, a range in natural period may be preferable to an approximate single value. Because of the limited range of conditions upon which it was based, the Makdisi and Seed method is not considered appropriate for evaluation of significant- or high-haz-

ard-potential coal refuse impoundments unless the embankment under consideration approximates a triangular configuration or more conservative configuration (with respect to seismically-induced deformation) and is founded on materials that are not susceptible to cyclic mobility.

7.5.5 Numerical Modeling with No Cyclic Mobility

If stress reversal and cyclic mobility are not likely (i.e., if $CRR/CSR > 1.0$, as discussed in [Section 7.5.1](#)), then Newmark analyses may be used. An alternative to Newmark analyses for this case is computer modeling based on finite-element or finite-difference analyses.

With finite-element modeling, the cross section of the structure is divided into a grid of discrete (finite) elements that connect to each other at node points. The elements are assigned material properties such as unit weight, Poisson's ratio, and stress-strain properties. Loads (forces) are applied at the node points, and displacements at the node points are computed by solving the stiffness matrix for the assembly of finite elements. Strains and stresses within elements are computed based on the displacements at the node points and the material properties.

With finite-difference modeling, the cross section of the structure is divided into a grid of lumped masses that interact with each other in accordance with constitutive equations based on the material properties. The displacements resulting from forces applied to the lumped masses in the grid are computed by solving the equations of motion (force equals mass times acceleration) at sequential time steps.

One of the key issues is assigning appropriate material properties (especially stress-strain properties) to the elements. Various non-linear soil models have been developed that, when used properly, can reasonably model material behavior when cyclic mobility does not occur. The soil models can be complex, and using them without fully understanding them can lead to errors. The results of the analyses are often sensitive to relatively minor variations in the parameters used to define the stress-strain properties. Checking the sensitivity by varying the parameters is an important part of the analysis. It is also important to check the model output to be sure that the pattern of stresses and strains across the cross section of the structure appears reasonable.

7.5.6 Numerical Modeling Considering Cyclic Mobility

If stress reversal and cyclic mobility are likely, (i.e., if $CRR/CSR < 1.0$) then the evaluation of deformations becomes highly uncertain, and Newmark analyses ([Section 7.5.4](#)) are not appropriate. Finite-element or finite-difference numerical models can be used, but the stress-strain models must have special provisions to account for cyclic mobility. These models are particularly complex because they model the S-shaped, stress-strain curve associated with cyclic mobility (very low stiffness at low to moderate strains followed by dilation and increasing stiffness at high strains). An example of such a stress-strain model is presented in Byrne et al. (2004). It is particularly important to check the output of these analyses for sensitivity to modeling parameters and for reasonableness. The U.S. Army Corps of Engineers demonstrated a procedure using commercially available finite-difference software (FLAC) and a modified version of the UBSAND model (Byrne et al., 2004) to conduct a deformation analysis for a dam in California, including comparison of the results with somewhat more simplified methods (Perlea et al., 2009).

Cyclic mobility is most likely to be a concern for cases of upstream construction in areas of medium to high seismic risk. Deformation analyses of complex embankment-foundation configurations and situations where significant zones of the structure are subject to cyclic mobility require experience with numerical analysis techniques (e.g., finite element and finite difference) and soil behavior constitutive models. An experienced user of the selected modeling software for deformation analyses should be involved in the modeling and/or validation of the results.

7.5.7 Acceptable Deformations

Once estimates of deformation have been made, the question arises as to what values of deformation are considered acceptable and what values are considered excessive. For embankments that do not retain liquids, fine coal refuse, or similar materials, deformations are not normally a problem so long as the embankment is stable. For dams or embankments that do retain liquids, fine coal refuse, or similar materials, deformations should be small enough that:

- Freeboard is not significantly compromised.
- Cracking through the dam, which affects the integrity of the dam for retaining liquids or might allow a release of material, does not occur.
- Appurtenant structures that affect dam safety are not severely damaged.
- Affected structures can be repaired before they might deteriorate further and pose a greater hazard.

The following are generally considered acceptable:

- Downstream analyses – Computed displacements or deformations less than 25 percent of the available freeboard and less than 3 feet.
- Upstream analyses – Computed displacements or deformations less than 25 percent of the available freeboard and less than 6 feet.

7.6 EMBANKMENT MODIFICATIONS FOR IMPROVING STABILITY OR RESISTANCE TO DEFORMATIONS

Measures to improve the seismic stability and the resistance to deformations of new and existing facilities can be grouped into the following general categories:

- Changes to embankment geometry (e.g., flatter slopes, buttressing, wider coarse refuse zone)
- Drainage control measures (including both internal and surface drainage)
- Soil/refuse improvement or reinforcement
- Increased freeboard

These measures are discussed in Chapter 6.

7.7 SEISMIC HAZARD ASSESSMENT (SEISMICITY)







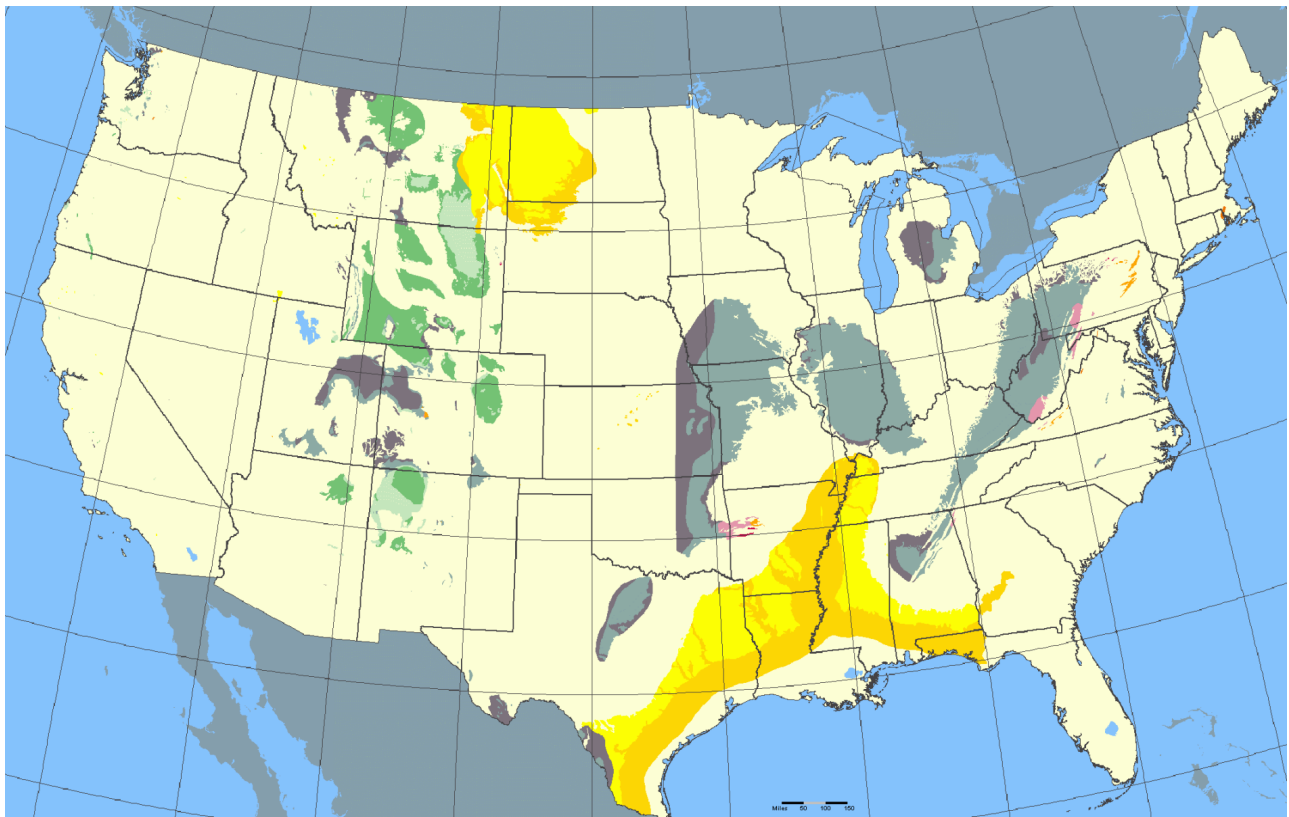



The purpose of a seismic hazard assessment is to estimate the appropriate design earthquake(s) for a site in terms of earthquake magnitude (M) and peak ground acceleration (PGA) and, when needed, to define representative time histories of ground motions.

This discussion of recommended procedures for deriving the seismic hazard is intended to be applicable in the U.S. where coal is mined. [Figure 7.17](#) shows the various regions where anthracite, bituminous and lignite coals are mined. Although the greatest amount of coal production is from the western U.S., the type of coal processing in that region does not typically require the construction of tailings dams for coal refuse. Accordingly, the procedures defined to derive seismic hazard place emphasis on eastern U.S. conditions, which are different from the western U.S. in many respects, as discussed in [Section 7.7.1](#).

Anthracite coal is mined in eastern Pennsylvania. Bituminous coal deposits in the eastern U.S. are found in the Appalachian, Illinois, Michigan, and the Western Interior Basins, with some bituminous coal also found within the Gulf Coast lignite deposits ([Figure 7.17](#)). These sources, primarily anthra-



LEGEND

	ANTHRACITE/OTHER USES
	ANTHRACITE/POTENTIALLY MINABLE
	LIGNITE/OTHER USES
	LIGNITE/POTENTIALLY MINABLE
	LOW VOLATILITY BITUMINOUS/OTHER USES
	LOW VOLATILITY BITUMINOUS/POTENTIALLY MINABLE
	MEDIUM AND HIGH VOLATILITY BITUMINOUS/OTHER USES
	MEDIUM AND HIGH VOLATILITY BITUMINOUS/POTENTIALLY MINABLE
	SUB-BITUMINOUS/OTHER USES
	SUB-BITUMINOUS/POTENTIALLY MINABLE

NOTE: IMAGE WAS OBTAINED FROM THE USGS "NATIONAL ATLAS" WEB SITE AND WAS COMPILED BY THE USGS EASTERN ENERGY RESOURCES TEAM (EERT).

FIGURE 7.17 LOCATION OF U.S. COAL RESOURCES

cite in eastern Pennsylvania and bituminous in the Appalachian and Illinois Basins, are where coal needs to be processed and where coal refuse impoundments are required. Within these large areas, the seismic hazard is not uniform and can range from being nearly insignificant to an important design consideration.

The U.S. Geological Survey (USGS) has prepared national seismic hazard maps based on probabilistic analyses that define the variation of seismic hazard throughout the conterminous U.S., Alaska, Hawaii, Puerto Rico and the U.S. Virgin Islands, among other regions. Figures 7.18 and 7.19 present USGS seismic hazard maps respectively for the PGA with a 10 percent and 2 percent probability of exceedance in 50 years (~500 year and ~2,500-year return periods, respectively) in the conterminous U.S. Surface or near-surface active faults are the main sources of seismic hazard in the western U.S., whereas the eastern U.S. coal fields are affected primarily by three less-well-defined seismic sources: the New Madrid Seismic Zone, the Eastern Tennessee Seismic Zone, and the Charleston, South Carolina Seismic Zone (Figure 7.20). The coal fields with the most significant seismic hazard

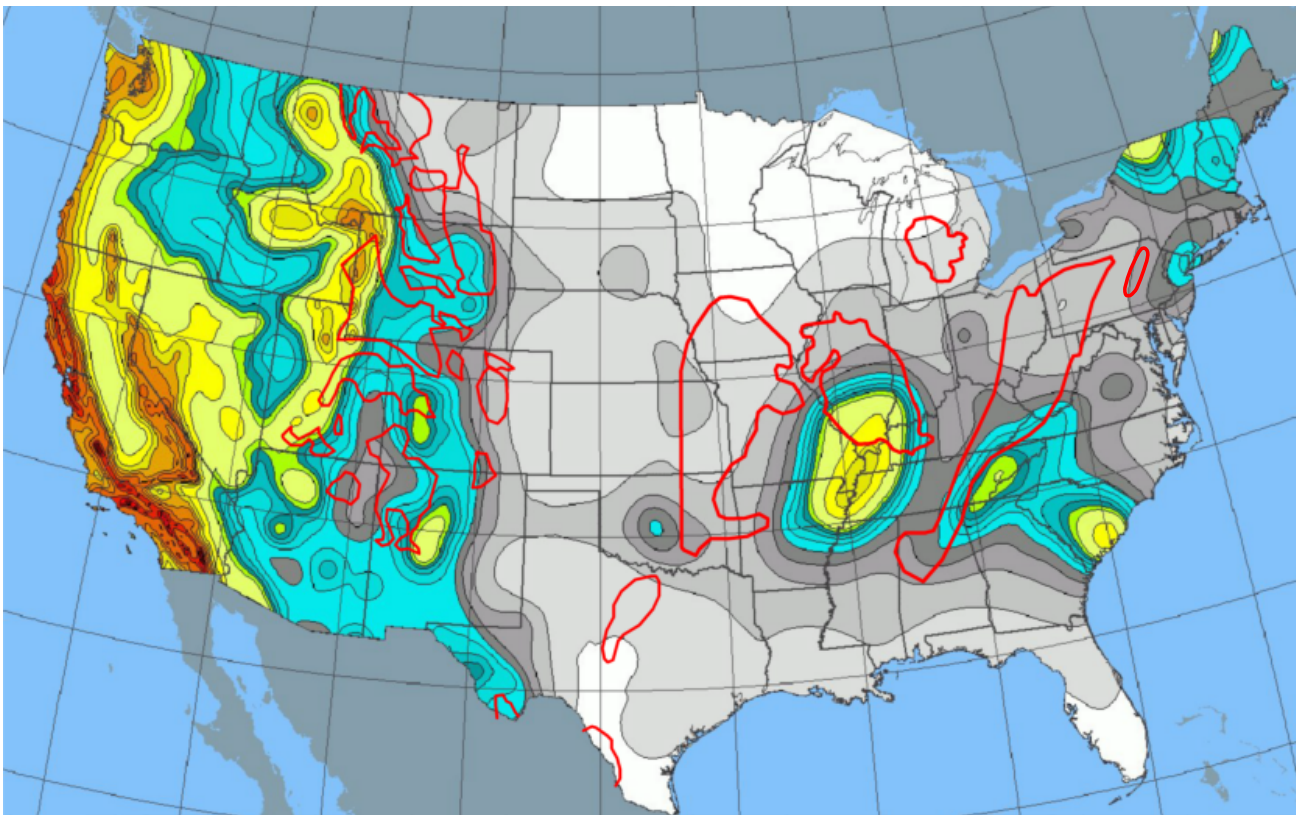

LEGEND

PEAK HORIZONTAL GROUND ACCELERATION
IN % g WITH A 10% PROBABILITY OF
EXCEEDANCE IN A 50-YEAR PERIOD

	20		5
	15		4
	10		3
	9		2
	8		1
	7		0
	6		

- NOTE: 1. IMAGE WAS OBTAINED FROM THE USGS "NATIONAL ATLAS" WEB SITE AND WAS COMPILED BY THE USGS GEOLOGIC HAZARDS TEAM.
2. ANTHRACITE AND BITUMINOUS COAL FIELDS ARE DENOTED BY RED BORDERS.

FIGURE 7.18 SEISMIC HAZARD MAP OF THE U.S. WITH OVERLAY OF MAIN BITUMINOUS COAL FIELDS

in the eastern U.S. are those in the southern half of the Illinois Basin. Portions of the coal fields in the southern Appalachians have moderate hazard. The Michigan and Western Interior Basins have very low hazard.

Seismic evaluation of coal refuse facilities and embankment dams requires the estimation of at least two ground motion parameters (earthquake magnitude and PGA). Another factor that needs to be considered in association with these two parameters is frequency content. Earthquake magnitude is critical because of the general relationship of magnitude and duration, as well as the strength of ground motion and related parameters such as frequency content, attenuation characteristics, etc. In essence, the larger the earthquake magnitude, the longer the earthquake, which implies that the soil will have to resist a greater number of ground-motion cycles of greater magnitude. Magnitude is not the only consideration in evaluating earthquake duration, as variations in fault mechanism, distance from the source, and local geologic conditions also contribute to duration, but acceptable practice is to consider

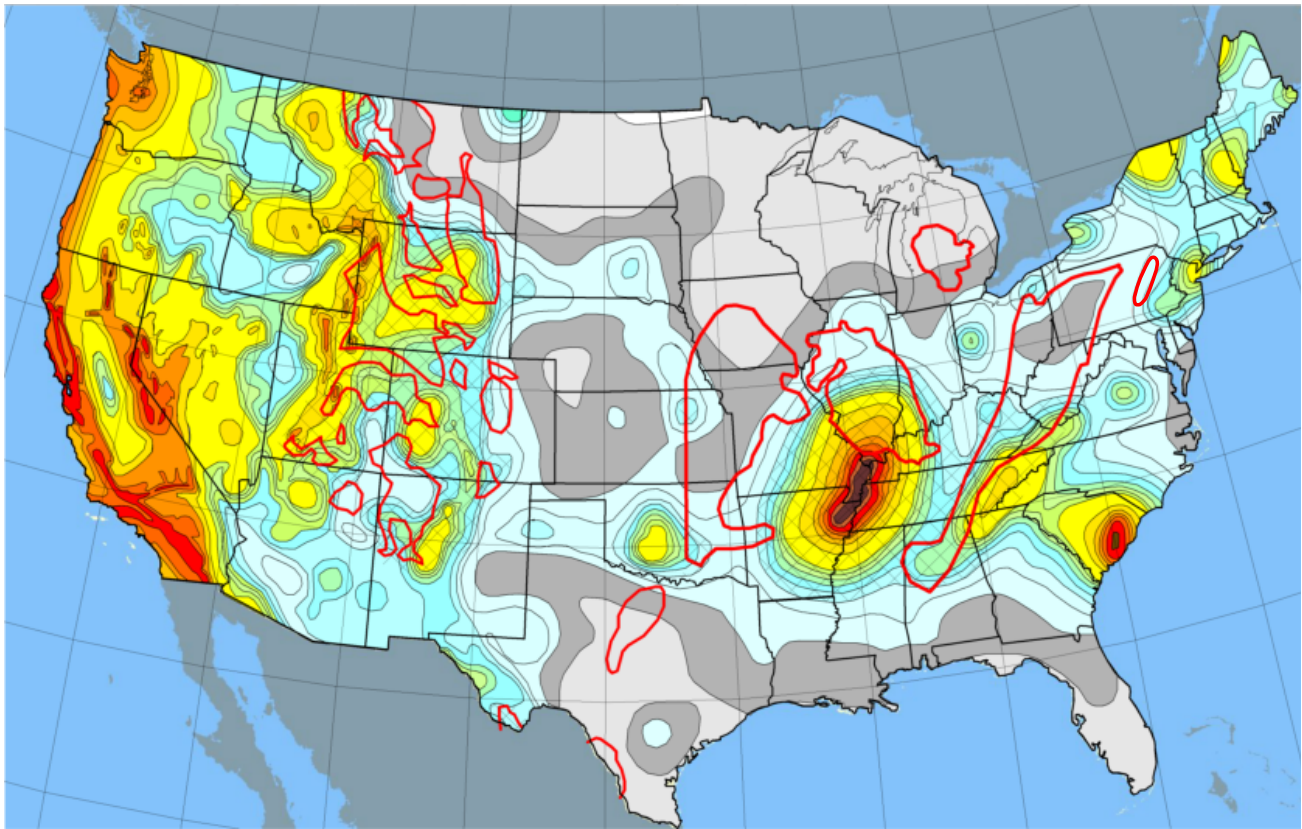

LEGEND

PEAK HORIZONTAL GROUND ACCELERATION IN % g WITH 2% PROBABILITY OF EXCEEDANCE IN A 50-YEAR PERIOD (2475-YEAR RETURN PERIOD).

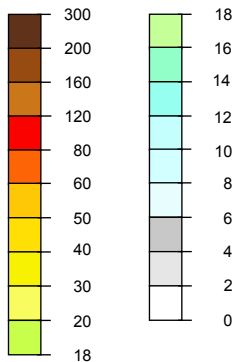

ZONE WHERE COMPLETE DSHA OR PSHA IS REQUIRED FOR EVALUATION OF SEISMIC HAZARD. BY INFERENCE, A SIMPLIFIED EVALUATION OF SEISMIC HAZARD IS PERMISSIBLE IN ALL OTHER AREAS.

- NOTE: 1. IMAGE REDRAWN FROM 2002 HAZARD MAP FOR A 2% PROBABILITY OF EXCEEDANCE IN 50 YEARS FROM THE USGS "NATIONAL ATLAS" WEB SITE.
 2. ANTHRACITE AND BITUMINOUS COAL FIELDS ARE DENOTED BY RED BORDERS.

FIGURE 7.19 ILLUSTRATION OF MODERATE- TO HIGH-HAZARD REGION

duration as a function of magnitude (Youd et al., 2001). PGA is the most commonly used parameter to define the strength of ground motion, but its significance also depends on frequency content. The actual seismic hazard will depend on the combination of duration and ground motion strength. With respect to dams and embankments, a single cycle of high PGA at a high frequency (in the range of 0.25 to 0.45g at a predominant frequency of 25 Hz) will likely not be as significant as a larger number of cycles of lower acceleration (in the range of 0.10 to 0.15g at 1 Hz). The reason for this is that for a dam to be significantly excited by earthquake ground motion, some portion of the ground motion must be close to the predominant frequency of the dam. A simple method for estimating the predominant frequency of an embankment based on height and shear-wave velocity of the embankment materials is provided by Makdisi and Seed (1977). For a typical coal refuse dam ranging in height from 100 to 400 feet and with

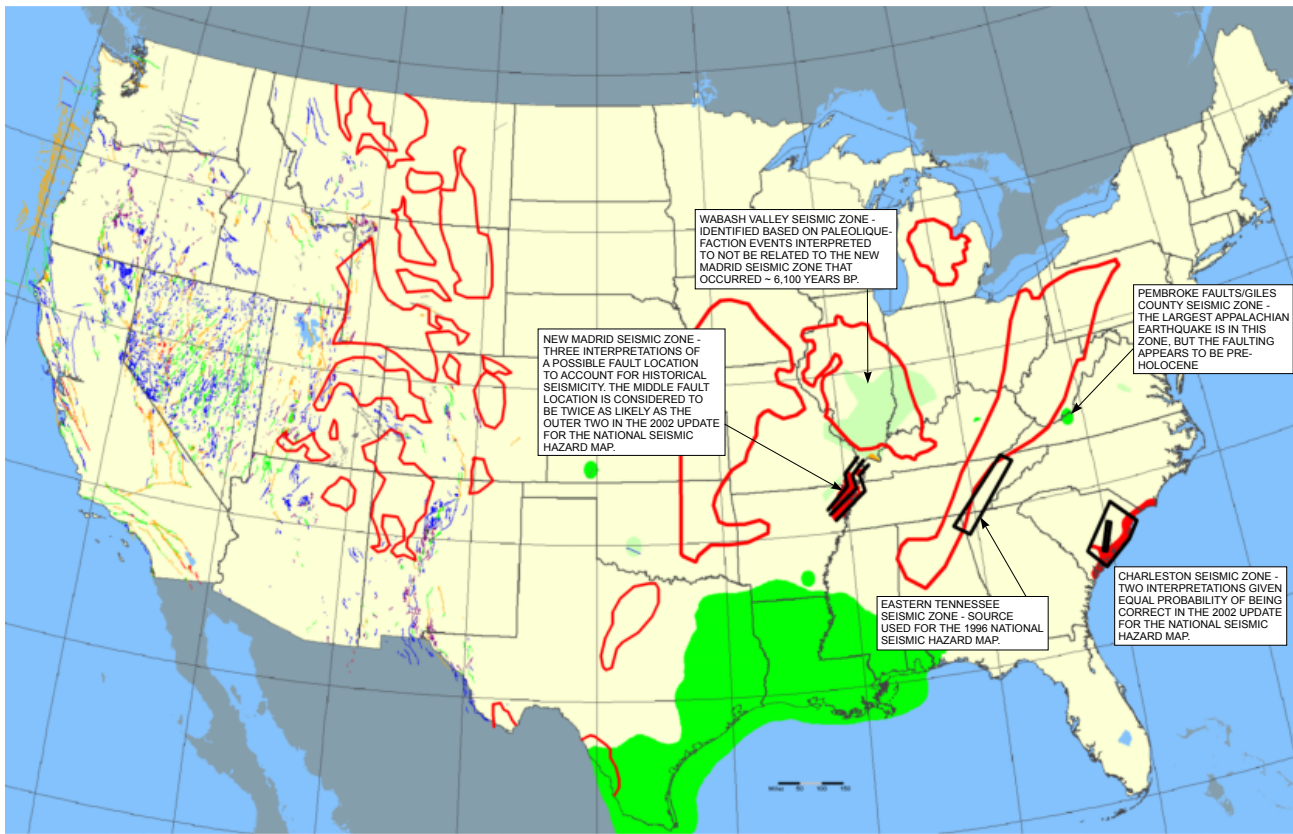

LEGEND

AGE OF QUATERNARY FAULTING

- HISTORIC
- HOLOCENE (< 15,000 YEARS AGO)
- LATE QUATERNARY (< 130,000 YEARS AGO)
- MID-LATE QUATERNARY (< 750,000 YEARS AGO)
- QUATERNARY (< 1.6 MILLION YEARS AGO)
- POSSIBLY OLDER THAN QUATERNARY
- OBSERVED EVIDENCE OF PALEOLIQUEFACTION

- NOTE: 1. IMAGE WAS OBTAINED FROM THE USGS "NATIONAL ATLAS" WEB SITE AND WAS COMPILED BY THE USGS GEOLOGIC HAZARDS TEAM.
2. BITUMINOUS COAL FIELDS ARE DENOTED BY RED BORDERS.

FIGURE 7.20 QUATERNARY FAULTS AND SIGNIFICANT SEISMIC SOURCES WITH OVERLAY OF MAIN BITUMINOUS COAL FIELDS

average shear wave velocities ranging from 500 to 1,600 ft/sec, the predominant frequency for the first mode of vibration could range from about 0.5 to 6 Hz. Accordingly, coal refuse dams are more likely to be affected by low-frequency ground motion, implying that more than one earthquake source may need to be considered in order to fully characterize the seismic hazard at a given site.

FEMA (2005b) defines the following design earthquakes:

- Maximum Credible Earthquake (MCE) – The MCE is the largest earthquake magnitude that could occur along a recognized fault or within a particular seismotectonic province or source area under the current tectonic framework.
- Maximum Design Earthquake (MDE) or Safety Evaluation Earthquake (SEE) – This is the earthquake that produces the maximum level of ground motion for which a structure is to be designed or evaluated. The MDE or SEE can be set equal to the MCE or to a design earthquake less than the MCE, depending on the circum-

stances. Factors to consider in establishing the size of MDE or SEE are the hazard potential classification of the dam (FEMA 2004a), criticality of the project function (water supply, recreation, flood control, protection of the environment, etc.), and the turnaround time to restore the facility to operability. In general, the associated performance requirement for the MDE or SEE is that the project performs without catastrophic failure (such as uncontrolled release of a reservoir) although significant damage or economic loss may be experienced. If the dam contains a critical water supply reservoir, the expected damage should be limited to an extent that allows the project to be restored to operation within an acceptable timeframe.

- **Operating Basis Earthquake (OBE)** – The OBE is an earthquake that produces ground motions at the site that can reasonably be expected to occur within the service life of the project. The associated performance requirement is that the project functions with little or no damage and without interruption of function. The purpose of the OBE is to protect against economic losses from damage or loss of service. Therefore, the return period for the OBE may be based on economic considerations.

Coal refuse impoundments and other mining dams often have significant or high hazard potential, and recommendations for selection of the MDE and seismic hazard assessment are presented in [Table 7.6](#). To protect site operational personnel, the public and the environment, it is necessary to design coal refuse impoundments having high hazard potential so that catastrophic failure does not occur. This is normally accomplished by considering the MCE when developing the design earthquake. The MCE might be represented by more than one earthquake event (i.e., from near-field and far-field sources) for which the structure should fail catastrophically. For coal refuse impoundments and dams having significant hazard potential, some federal dam safety agencies are giving consideration to events with return periods of the order of 2,500 years for design earthquakes. Further guidance on return-period criteria for significant- and high-hazard-potential dams is anticipated in the future from federal dam safety agencies.

Although the OBE does not typically govern the safe design of a coal refuse impoundment, it is still recommended that an OBE be defined on the basis of its probability of occurrence during the life of the dam. A 500-year (or more precisely 475-year) return period is consistent with the basis for defining an OBE in some conventional building codes and corresponds to one of the hazard maps published by the USGS (corresponding to a 10-percent probability of non-exceedance event for a 50-year lifetime), as shown on [Figure 7.18](#). The OBE earthquake parameters should be used to check the reasonableness of the design MCE. It is expected that the MCE will be a remote event with a PGA substantially higher than the OBE.

7.7.1 Analytical Procedures

Two approaches, probabilistic seismic hazard analysis (PSHA) and deterministic seismic hazard analysis (DSHA), are commonly applied to estimation of earthquake ground motions at a site. Fundamentally, only a DSHA can be used to estimate the Maximum Credible Earthquake (MCE). In PSHA, an MDE is associated with a return period far beyond the life span of the structure and is associated with a very low probability of occurrence.

7.7.1.1 Deterministic Seismic Hazard Analysis (DSHA)

The basic steps in a DSHA are as follows:

1. Develop a seismotectonic model. Review and summarize the basic geology and tectonics of a region surrounding the site (approximately 322-km radius) with particular attention to specific seismic sources, both area sources (provinces) and linear

TABLE 7.6 MDE AND SEISMIC HAZARD ASSESSMENT RECOMMENDATIONS

Dam Hazard Potential Classification	Maximum Design Earthquake (MDE)	Seismic Hazard Assessment	
		Low-Seismic-Hazard-Potential Area ⁽¹⁾	Moderate- to High-Seismic-Hazard-Potential Area ⁽¹⁾
High Hazard Potential	MCE ⁽²⁾	Simplified Minimum EQ and Simplified Design Ground Motion ⁽³⁾ or Site-specific DSHA ⁽²⁾ supported by PSHA ⁽⁴⁾	Site-specific DSHA ⁽²⁾ supported by PSHA ⁽⁴⁾
Significant Hazard Potential	MDE ~ 2500 return period ⁽⁵⁾	USGS EQ Hazard Maps or Site-specific PSHA	USGS EQ Hazard Maps or Site-specific PSHA

- Note:
1. Low-seismic-hazard-potential areas, as defined in this Manual, are distinguished using the USGS Earthquake Hazard Maps for a return period of 2,500 years with a $PGA \leq 0.1g$ and $M \leq 5.5$. All other areas are considered moderate- to high-seismic-hazard-potential areas.
 2. The Maximum Credible Earthquake (MCE) derived on the basis of a DSHA, as described in Section 7.7.1.1, is recommended as the MDE for high-hazard-potential dams based on FEMA (2005b). If a PSHA is used to establish the MDE for a high-hazard-potential facility, the designer should be able to demonstrate that the probability of occurrence is very remote (the actual return period may be a function of the seismic hazard area and tectonic conditions).
 3. See Section 7.7.3.7 for Simplified Design Ground Motion and Simplified Minimum Earthquake (EQ) description.
 4. The results of a Probabilistic Seismic Hazard Assessment (PSHA) can aid in demonstrating that the probability of catastrophic failure is very remote and in deciding whether mean, or mean-plus-one standard deviation or greater estimates of ground motion, would be justified for the MDE from the deterministic ground motion analysis to achieve an acceptably low probability of exceedance (FEMA, 2005b).
 5. For a significant-hazard-potential facility, the designer should be able to demonstrate that the probability of catastrophic failure is remote. The actual return period may be a function of the seismic-hazard area and tectonic conditions (e.g., consideration of a return period of the order of 2,500 years may be reasonable for low-seismic-hazard areas).

sources (faults). Note that a 332-km (200-mile) potential radius of influence has been chosen in order to account for the susceptibility of fine tailings to liquefaction effects from large, distant earthquakes.

2. Conduct a review of the seismic history of the site's region; locate the epicenters of all significant earthquakes and plot these earthquakes on a map that shows magnitude values.
3. Relate these epicenters to the mapped sources defined in Step 1.
4. Based on the results of Step 3, postulate a group of conceivable MCEs by selecting the most severe earthquake within or along each source that could be larger than the largest historical earthquake and "move" each earthquake to the point on the respective source nearest to the site.
5. Derive the ground motion at the site in terms of PGA on the basis of regionally applicable attenuation functions (i.e., relationships that allow the estimation of ground motion parameters at the site as a function of earthquake magnitude, source-to-site distance, and soil conditions at the site).
6. From the various PGAs obtained in Step 5 for the group of conceivable MCEs from Step 4 (applying the minimum distances from source-to-site), determine the most severe ground motion and classify this motion as the MCE. In the case of dams and embankments, the most severe earthquake event is not simply a function of the site-specific PGA, so it might not be apparent that a single event controls. A distant,

large-magnitude earthquake might not be associated with a PGA as high as for a smaller magnitude, nearer event, but such a distant earthquake could pose a greater threat because of its greater energy content and potential to induce more cycles of significant vibrations around the natural damped frequency of vibration of the structure-foundation system. Consequently, an examination of representative ground motions for more than one event might be necessary (Step 7).

7. Associate the MCE ground motion(s) to time history(ies) of ground motion consistent with the magnitude of the source and, with lesser emphasis, the calculated PGA from that source.

The ground conditions for which the selected attenuation functions in Step 5 are applicable require consideration when determining where on or in the ground the derived ground motion should be applied in site-specific dynamic analyses of the structure-foundation system. For example, some attenuation functions are only applicable to site conditions characterized by firm rock and thin, very stiff soil. Hence, the derived ground motion at a site with less stiff or thicker soil overburden should be applied at the top of rock, rather than at the ground surface. Depending on the site conditions, this derivation of ground motion at the top of relatively soft ground could be accomplished using the SHAKE program (Schnabel et al., 1972) or other similar approach as further discussed in [Section 7.4.2.2.1](#) and [7.5](#).

7.7.1.2 Probabilistic Seismic Hazard Analysis (PSHA)

A PSHA requires the same basic input as the DSHA in terms of the definition of seismotectonic models and attenuation functions to characterize site ground motion. However, the results from PSHA and DSHA are fundamentally different. PSHA addresses the chance of a given level of ground motion being exceeded from all possible earthquakes.

The methodology used for the PSHA is well established in the literature (Cornell, 1968; McGuire, 1976; McGuire, 1978). PSHA is the methodology used by the USGS to derive the seismic hazard of the United States, and details of the procedures followed are described by Frankel et al. (1996). Calculation of the seismic hazard requires specification of the same inputs as required for the DSHA, except with the additional requirement that the uncertainties associated with each input need to be quantified:

- Source geometry – the geographic description of the seismic sources in the region of influence around the site. A seismic source is a portion of the earth associated with a tectonic fault or (if individual faults cannot be identified) with an area/province of homogeneous seismicity. Source geometry determines the probability distribution of distance R from the earthquake to the site $f_R(r)$.
- Seismicity – the rate of occurrence ν and the magnitude distribution $f_M(m)$ of earthquakes within each seismic source.
- Attenuation functions – the definition of attenuation functions is the same as with the DSHA, except that it is important to define the uncertainty of each possible function.

One consideration related to uncertainties with each input is how to weight the events within a seismic source and weight the influence of a source. The USGS report, “Documentation for the 2002 Update of the National Seismic Hazard Maps,” prepared by Frankel et al. (2002), explains the data, evaluations, judgments and assumptions behind their PSHAs for different regions.

Mathematically, the calculation of whether the annual probability $\lambda Y > y$ the ground-motion characteristic parameter Y , expressed in terms of peak ground acceleration PGA or spectral acceleration S_a for various frequencies of vibration, exceeds level y involves the summation, over seismic sources that may pose a threat to the site, of the following relationship:

$$\lambda Y > y = \sum_{i=1}^N v_i \left\{ \int_{r_{min}}^{r_{max}} \int_{m_l}^{m_u} P[Y > y | m, r] f_{M,R}(m, r) dm dr \right\}_i \quad (7-7)$$

where:

- N = number of the nearby seismic sources, including both line sources (i.e., active faults) and area sources
- v_i = annual mean rate of occurrence of earthquakes generated by source i with magnitudes between m_l and m_u
- r_{min} = minimum source-to-site distance for source i
- r_{max} = maximum source-to-site distance for source i
- m_l = lower-bound values of magnitude for source i
- m_u = upper-bound values of magnitude for source i

and:

- $P[Y > y | m, r]$ is the conditional probability that the site may be struck by a ground motion with parameter $Y > y$ generated by an earthquake of magnitude $M = m$ with epicenter in source i at distance $R = r$ from the site.
- $f_{M,R}(m, r)$ is the joint probability density function of magnitude M and distance R for source i

Hence the expression within brackets in Equation 7-7 is the probability that at the site an earthquake with parameter $Y > y$ will occur because a seismic event of magnitude m ($m_l \leq m \leq m_u$) originated anywhere in source i .

Ground motion at the site is modelled by an attenuation function, which is a mathematical equation that defines the relationship between the ground-motion parameter Y , earthquake magnitude, source-to-site distance and local soil condition at the site. The attenuation function is used to compute the conditional probability in the integrand of Equation 7-7. Note that the USGS hazard maps are for a “firm-rock site condition, where the shear-wave velocity averaged over the top 30 meters (V_{s30}) is 760 meters per second (boundary of NEHRP site classes B and C).” On a practical level, this means that the USGS has not tried to model site-specific conditions. If there are site-specific conditions that need to be accounted for, an extra step in the analysis is required.

If a scalar parameter such as peak ground acceleration (PGA) is chosen, the repetition of these calculations for different values of the threshold level y allows the construction of the seismic hazard curve for the site (a plot of annual probability of exceedance, or return period, versus the parameter level). If the parameter of the ground motion is expressed in terms of spectral acceleration, $S_a(f, \xi)$, a family of seismic hazard curves for the site can be evaluated for various values of f and ξ (f is the frequency and ξ is the percentage of the critical damping). These results based on spectral ordinates can also be rearranged in order to obtain Uniform Hazard Spectra (UHS) (McGuire, 1974), which represent the response spectra whose ordinates are associated with the same probabilities of exceedance at the site. These methods that make use of spectral quantities include those that employ only a high-frequency parameter such as PGA.

7.7.1.3 DSHA versus PSHA

Regardless of whether seismic hazard is defined by a DSHA or PSHA methodology, the results still have some degree of uncertainty. The advantage of PSHA is that it can incorporate a range of uncer-

tainties inherent in the seismotectonic model, occurrence frequency, and ground-motion attenuation relationships, that is not possible with a DSHA approach. However, PSHA has some significant limitations, especially in terms of selecting ground motion parameters that can be considered representative of a maximum credible event (MCE). A discussion of the limitations of the PSHA approach for defining the seismic input for critical facilities is presented by Krinitzsky (1995).

Selection of the design ground motion parameters from a PSHA is complex because there are infinite points (choices) on the hazard curve. It is not practical to pick a point from a hazard curve and be able to relate it to the ground motion representing a reasonable worst case. Furthermore, the ground motion derived from PSHA does not have a clear physical meaning (Wang et al., 2003), because the total hazard (total annual frequency of exceedance) at a site is the sum of the individual hazards (annual frequency of exceedance) and is not associated with any individual earthquake, but potentially many earthquakes. For example, on the 2002 USGS national seismic hazard maps, the total seismic hazard in Chicago, Illinois was derived from a series of earthquakes with magnitudes ranging from 5.0 to 8.0 at distances ranging from 0 to 500 km (Harmsen et al., 1999). Therefore, it can be difficult to identify from the results of a PSHA a specific earthquake that represents a worst case scenario.

Although the earthquake magnitude and PGA are not physically related, the USGS Earthquake Hazards Program now provides probability mapping for earthquake magnitude (Moment Magnitude M within 50 km of a site as discussed in [Section 7.7.2.5](#)) as well as PGA, which allows for definition of a local earthquake event by M and PGA for a selected return period or probability. (The USGS provides maps of PGA for return periods up to a 2,475-year event, although the PGA for a 4,975-year return period can be computed on the basis of available site-specific deaggregations.) The use of the USGS hazard mapping to arrive at these parameters does not provide any specific insight to the controlling source and earthquake event, or a representative ground motion, but should provide a reasonable set of design parameters for lower seismic hazard sites for a given return period or probability, as each variable would be statistically represented by the maximum mean value. Then actual ground motion records for locations within 50 km of past earthquakes of magnitude “ M ” not less than the design M can be adopted in design, in lieu of attempting to identify the controlling source earthquakes and to derive attenuated ground motions from each of those events.

The primary advantage of the DSHA approach in terms of defining the seismic hazard for a structure like a dam or embankment is that it deduces a particular seismic scenario, consisting of the postulated occurrence of an earthquake of a specified size at a specified location upon which a ground-motion-hazard evaluation is based. A DSHA approach provides ground-motion parameters from those earthquakes that have the most significant impacts. This is particularly advantageous for seismic design and analysis of dams and embankments.

As noted previously, the design basis for high-hazard-potential dams and impounding embankments is generally the MCE. Fundamentally, probability is not a consideration for the MCE, except as verification that the MCE is an extremely remote event. Previous designs for some coal refuse impoundments in some areas of the northern Appalachian and Illinois Basins have associated a 10,000-year return period with a MCE event, absent a detailed site-specific study or the availability of a detailed study from a similarly critical nearby structure/facility. This return period is at the upper end of typical recommendations (USCOLD, 1999). [Table 7.6](#) presents recommendations for the seismic hazard assessment (and design earthquake), and the subsequent sections of this chapter describe development of the design ground motion based on a DSHA, which yields an earthquake magnitude, peak horizontal ground acceleration, and associated time histories/response spectra. The procedures presented herein include verification that the design earthquake is an extremely remote event, through comparison with published return periods or results of a PSHA. If a designer elects to base the design for a high-hazard-potential dam on a PSHA, the return period should be established such that the

MDE can be equated to the controlling MCE, as cited in FEMA (2005b). Further PSHA guidance on return-period criteria for significant- and high-hazard-potential dams is anticipated in the future from federal dam safety agencies.

7.7.2 Seismotectonic Modeling

Most seismotectonic studies and publications focus on the western U.S. where there is a relative abundance of data and observations. The seismotectonic modeling of the central and eastern U.S. requires that the differences between the eastern and western U.S. be appreciated. The following characteristics of eastern U.S. earthquakes represent significant differences when compared to the western U.S.

- More than an order of magnitude lower seismicity rates (longer recurrence periods for the same magnitudes).
- General lack of surface faulting, such that it is difficult to define source models
- Slower attenuation of ground motions with distance, which implies larger areas of damage for the same earthquake magnitude.
- Higher high-frequency content of seismic ground motions to larger distances.
- Relatively higher site amplification where soft soil is over rock (considered to be more significant in glaciated areas where the contact with highly competent rock is abrupt; Youd et al., 2001).
- Greater uncertainty in quantitative hazard assessments because the historic seismicity record (300 years) is too short compared to the recurrence periods of major damaging events.
- Few sets of eastern strong-motion data exist. They marginally constrain the attenuation of shaking with distance, as well as the dependence of local ground motion on magnitude, distance and depth of the earthquake.
- Higher frequency content of eastern earthquakes may lead to a greater number of cycles for the same magnitude.

In spite of the differences between eastern and western U.S. seismic events and the limitations of the eastern U.S. database, these factors can be accounted for in a seismic hazard analysis. The high-frequency motions associated with eastern earthquakes are generally limited to near-field rock sites. These motions tend to attenuate rapidly when they propagate through soil, which effectively reduces the amount of energy and the number of pertinent ground motion cycles that could contribute to the hazards of seismically-induced strength loss or ground deformation. Therefore, as noted by Youd et al. (2001), the duration differences between eastern and western soil sites are not likely to be significant when evaluating strength loss and ground deformations.

Compared with a plate boundary environment like California, an intra-plate environment like the central and eastern U.S. is difficult to characterize. Although there have been many recent advances in the understanding of earthquake occurrence based mainly on discoveries of paleoliquefaction phenomena, many gaps still exist in the knowledge of why and how often earthquakes occur in the central and eastern U.S., as summarized by the USGS Geologic Hazards Team (Crone and Wheeler, 2000) that supports the National Earthquake Hazard Reduction Program (NEHRP).

Defining a seismotectonic model for the central and eastern U.S. requires considerable judgment and is a subject of ongoing research. It is anticipated that it will be necessary to review the status of ongoing research whenever new seismic hazard assessments are required. This Manual includes some of the concepts and sources of information suitable for the derivation of seismic hazard at the time of publication, as summarized in the following subsections.

7.7.2.1 Regional Tectonic Framework

One of the major accomplishments with respect to the definition of seismic hazard in the central and eastern U.S. over the past 20 years is the definition of potential seismic sources on the basis of tectonic evidence. The zones where there has been Quaternary fault movement are summarized in [Figure 7.20](#). Fault sources are the dominant means for deriving seismic hazard in the western U.S. Fault sources are poorly defined in the central and eastern U.S., but recent work has identified a tectonic framework for earthquake occurrence, as summarized in Crone and Wheeler (2000). Recent data for the New Madrid Seismic Zone (NMSZ) is presented in Tuttle et al. (2002).

In terms of conducting a deterministic analysis, there is no agreement regarding the actual definition of the main seismic sources affecting the central and eastern U.S. Nevertheless, it is practical to use the sources that are currently defined by the USGS Geologic Hazards Team. The zones where Quaternary tectonic movements have been documented are predominantly in the New Madrid Seismic Zone, and the modeling of this zone has been considered to be as fault zones of varying probability, as shown in [Figure 7.20](#). This zone has significant influence to the southern Illinois Basin, as documented in the probabilistic hazard map shown in [Figure 7.18](#) for a 500-year return period and in [Figure 7.19](#) for a 2,475-year return period.

Another relatively recent discovery is the presence of paleoliquefaction in southern Illinois and Indiana ([Figure 7.20](#)), which was identified by Crone and Wheeler (2000) as the Wabash Seismic Zone. These widespread paleoliquefaction effects have been documented and interpreted to be associated with a large earthquake ($M \sim 7.5$) possibly centered in the Wabash Valley area between southern Illinois and Indiana that occurred about 6,100 years before the present (BP). Specific faults that produced the paleoliquefaction features have not yet been identified.

Within the Appalachian Basin coal fields, the most significant source is the Eastern Tennessee Seismic Zone, a belt of seismicity in northeastern Alabama, northwestern Georgia and much of eastern Tennessee ([Figure 7.20](#)). The largest historical shock was magnitude 4.6, and occurred in 1973. No evidence for larger prehistoric shocks has been discovered, yet the microearthquake data suggest coherent stress accumulation within a large volume (Chapman et al., 2002). The largest earthquake within the Appalachian system had a Modified Mercalli Intensity (MMI) equal to VIII ($M = 5.9$) and occurred on May 31, 1897 in Giles County, Virginia in the general area where evidence of Quaternary faulting has been uncovered. This faulting is referred to as the Pembroke Fault zone by Crone and Wheeler (2000). There is no surface expression of these faults and it is uncertain if they are due to tectonic movements or from solution collapse.

The third significant earthquake source in the eastern U.S. is the Charleston, South Carolina Seismic Zone. Paleoliquefaction data indicate that for characteristic large earthquakes in the Charleston, South Carolina region, the recurrence interval is approximately 550 years, as presented by Talwani and Schaeffer (2001). The USGS (Frankel et al., 2002) have assigned two source zones for this area with an equal probability of their validity. Although a significant seismic source in the eastern U.S., the effects of this zone do not significantly affect the Appalachian coal fields.

The definition of seismic source zones in the central and eastern U.S. based strictly on tectonics is still very much an evolving science. In conducting a deterministic analysis it will be necessary to carefully evaluate the most recent work of the USGS and other organizations, especially universities, involved with ongoing research into the identification of seismogenic tectonic structures. For example, the Mid-America Earthquake Center (MAE Center) is a good source of information for the central and eastern U.S. seismic hazard. The MAE Center, headquartered at the University of Illinois at Urbana-Champaign, is a consortium of nine core institutions funded by the NSF and each core university, as well as through joint collaborative projects with industry and other affiliations.

7.7.2.2 Historical Seismicity

The seismic hazard derived for locations in the central and eastern U.S. needs to be at least as severe as has been historically recorded. The National Earthquake Information Center of the U.S. Geological Survey and the Engineering Research and Development Center of the U.S. Army Corps of Engineers compile source and magnitude information for earthquake events. These sources also provide access to isoseismal maps of historical events and available strong motion records, although few are available for the central and eastern U.S. The seismic hazard evaluation process should consider the historical maximum Modified Mercalli Intensity experienced at the site, and the design ground motion should not be less than that corresponding to the maximum MMI. The correlation of MMI to PGA is not an exact science, but correlations developed for California such as developed by Wald et al. (1999) and adapted for use in the central U.S. by Atkinson and Kaka (2006) are worth considering.

7.7.2.3 Selection of Seismic Sources

To define the source zones for deriving seismic hazard, the distribution of earthquakes needs to be evaluated in the context of available information regarding Quaternary tectonic activity. In the western U.S., careful evaluation of surface and near-surface faults should be conducted in association with a review of historical seismicity, which is often of limited quality. It may be necessary to conduct site-specific studies of faults whose rupture could control the seismic design in order to determine their degree of activity and their physical characteristics, as summarized in detail by Slemmons and DePolo (1986). Such studies are seldom practical in the central and eastern U.S.

In many cases in the central and eastern U.S., earthquake distribution by itself is the basis for defining a seismic source. For example, the Eastern Tennessee Seismic Zone is defined primarily based on the distribution of instrumentally determined epicenters. The overall active zone in the New Madrid area has been similarly defined.

The seismic sources most critical to the central and eastern U.S. coal fields are those identified in [Figure 7.20](#). The fault sources that are significant to the definition of seismic hazard in the western U.S. coalfields are too numerous to describe in this Manual, and the reader is referred to lists and discussions provided by the USGS or state geological surveys. The interpretation presented in [Figure 7.20](#), which represents the current best interpretation of the USGS, and forms the basis for the National Seismic Hazard Maps (Frankel et al., 2002), examples of which are shown in [Figures 7.18](#) and [7.19](#), illustrates the current uncertainty with respect to the main sources affecting central and eastern U.S. coal fields. It should be emphasized that the presence of earthquakes is not an absolute criterion for delineating a seismic source zone. For example, the Wabash Valley Seismic Zone shown in [Figure 7.20](#) was developed based on the identification of paleoliquefaction phenomena. Other than for special areas of relatively high seismic hazard, the approach of the USGS to defining seismic hazard has been to construct hazard maps directly from the historic seismicity data following the procedure in Frankel (1995). The number of events greater than the minimum magnitude are counted on a grid with spacing of 0.1° in latitude and longitude. Accordingly, to develop the seismic hazard following a DSHA, it is necessary to develop source models more fully than the main sources defined by the USGS.

In addition to the USGS, there has been considerable effort by other organizations to delineate seismic sources in the central and eastern U.S. In particular, from 1981 to 1989, Lawrence Livermore National Laboratory (LLNL) developed a PSHA methodology for the eastern United States (Bernreuter et al, 1989), followed in 1993 by improvements in the handling of the uncertainties (USNRC, 1993). Differences between these results and those of a utilities-sponsored study (Electric Power Research Institute, 1989) led to the formation of the Senior Seismic Hazard Analysis Committee (SSHAC) to identify the sources of differences and give guidance on how to perform a state-of-the-art PSHA (USNRC,

1997). This work continues to be reviewed and updated (Savy et al., 2002). These documents provide different expert opinions regarding appropriate source models for the central and eastern U.S., and they are important sources for detailed information regarding the seismotectonics of the central and eastern U.S. Nevertheless, it is cautioned that the USGS modeling is not one of the source models considered, and that some of the experts involved in development of the seismic source models for the LLNL studies hold widely divergent interpretations, as documented in the review of the seismic hazard at USDOE sites (USDOE, 1996).

Another source of seismotectonic modeling information is the U.S. Army Corps of Engineers (USACE). The USACE seismic design manual, *Response Spectra and Seismic Analysis for Concrete Hydraulic Structures* (USACE, 1999), provides a detailed seismotectonic interpretation of the central U.S. in terms of a source model based on a comprehensive review of seismotectonic data, and it is a notable reference for the definition of seismic source zones in this area.

7.7.2.4 Maximum Magnitude

In either a deterministic or probabilistic analysis, it is necessary to identify the strongest earthquake that has occurred within each source and then determine if there is a reason to consider that a larger earthquake could reasonably be expected to occur. Substantial judgment is required for this assessment. For example, it may be reasonable to assume that the 1811-1812 earthquakes in the New Madrid Seismic Zone are a maximum event. However, the known historical seismicity in southern Illinois does not encompass the largest earthquake that could be produced in that area, given the widespread paleoliquefaction phenomena that have been mapped.

In an intraplate environment, the evaluation of maximum magnitude is especially problematic because the source mechanisms are poorly defined. Where source characteristics are well defined, such as along a mapped fault, common practice is to use relationships developed between earthquake magnitude and total fault length, rupture area, maximum displacement per event, fault slip rate and seismic moment (Slemmons and Depolo, 1986; Wells and Coppersmith, 1994 or several others). With some exceptions such as the Meers Fault in Oklahoma, these relationships can be applied only with considerable judgment in the central and eastern U.S.

DSHA is intended to define the worst-case ground motion and should therefore be based on the least favorable combination of earthquake source characteristics and location, and the strongest ground motion that could be generated by this scenario. In practice, DSHA generally uses the logarithmic mean or mean-plus-one-standard-deviation level of ground motion from predictive equations (Krinitzsky, 2002). If a mean plus a standard deviation is used, the ground motion will be conservative 84 percent of the time. A more detailed discussion of the difficulties in defining maximum magnitude is summarized by Bommer et al. (2004). Because of the uncertainties in the definition of maximum magnitude, the best approach is one of targeting a consensus opinion, such as is provided by the USGS Geologic Hazards Team (Frankel et al., 2002).

Another potential source of information regarding maximum earthquake magnitude is to consider probability of occurrence. In addition to the PGA hazard maps, the USGS (Frankel et al., 2002) also provides maps of the probability of occurrence of earthquakes of various magnitudes within specific distances of a given location as a function of return period. An example of a map depicting the probabilities (in terms of return periods) that an earthquake with $M > 5.5$ will occur within a distance of 50 km of different locations within the central and eastern U.S. is presented in [Figure 7.21](#). As this map was prepared by considering earthquake recurrence with a return period up to 10,000 years, the results show that large earthquakes are only reasonably conceivable in limited areas of the central and eastern U.S. and, conversely, that earthquakes of $M > 5.5$ are a remote possibility in most areas of the central and eastern U.S.

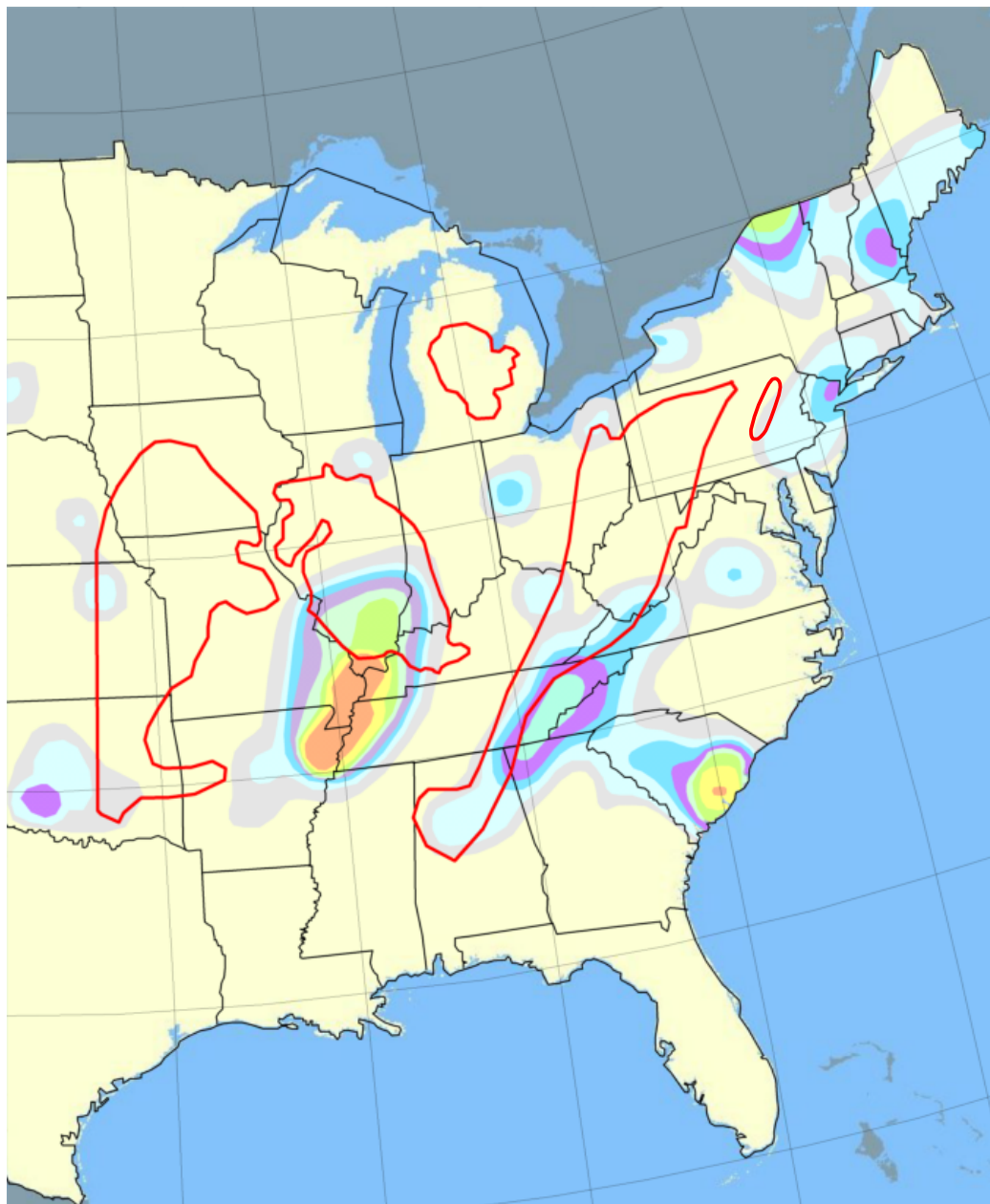

LEGEND

RETURN PERIOD IN YEARS FOR AN EARTHQUAKE OF $M > 5.5$ AT A DISTANCE OF LESS THAN 50 KM.

	9999
	7500
	4000
	3000
	2000
	1000
	500
	300

NOTE: 1. IMAGE REDRAWN FROM 2002 MAP BY THE USGS OF RETURN PERIOD FOR AN $M > 5.5$ EVENT AT A DISTANCE OF LESS THAN 50 KM.

2. ANTHRACITE AND BITUMINOUS COAL FIELDS ARE DENOTED BY RED BORDERS.

FIGURE 7.21 RETURN PERIOD FOR $M > 5.5$ EVENT AT A DISTANCE LESS THAN 50 KM

7.7.2.5 Earthquake Recurrence

The evaluation of earthquake recurrence for each source considered is a requirement of the PSHA. Recurrence is of interest to a DSHA if the distribution of earthquakes within a source as determined from the historical seismicity and geologic data as appropriate is suggestive that a maximum magnitude other than the historic maximum should be considered.

The determination of earthquake recurrence requires several steps:

1. Identification of both historical and instrumentally-located earthquakes within each postulated source.
2. Conversion of the available data into a common magnitude base. There are several magnitude scales, but for about the past 25 years it has been common practice to define magnitude in terms of seismic moment, as defined by Kanamori (1977) and Hanks and Kanamori (1979). Moment magnitude is the scale most commonly used for engineering applications and is the scale preferred for calculation of liquefaction resistance. The relationship between moment magnitude M and other commonly used magnitude scales can be reviewed as a chart published by Youd et al. (2001). In the central and eastern U.S., the most commonly derived magnitude scale is m_{blg} , which was developed by Nuttli (1973). Frankel et al. (1996) provide the following conversion to moment magnitude:

$$M = 3.45 - 0.473 m_{blg} + 0.145 (m_{blg})^2 \quad (7-8)$$

3. Evaluate the completeness of the earthquake catalog after the removal of statistically dependent events – aftershocks and foreshocks. Determination of catalog completeness is a function of location (e.g., earthquake history is better defined for a longer period in Charleston, South Carolina than in central Montana). Procedures for evaluating completeness are presented by Veneziano and Van Dyck (1985).
4. Formulate earthquake recurrence for each source. The most common means of defining recurrence is the Richter formula (Richter, 1958):

$$\log N = a - b m \quad (7-9)$$

where:

- m = earthquake magnitude
- N = number of earthquakes of magnitude m or greater per year per unit area
- a, b = constant coefficients defining a linear relationship between $\log N$ and m

This simple exponential recurrence model has been found to have good applicability for area sources, but there are many other ways to define the probability of earthquake recurrence, particularly when specific faults are considered (Schwartz and Coppersmith, 1986). It should also be noted that the simple Richter formula can be non-linear for the highest magnitudes and that caution should be used when estimating the recurrence of large magnitude events on the basis of limited historical data.

7.7.3 Design Ground Motion

The basic seismic data needed for determination of an MDE, including the MCE, is a time history(ies) representative of the source magnitude of the earthquake and a duration (number of cycles of strong ground motion) consistent with the source magnitude. The derivation of an MCE for a high-hazard-

potential dam involves a seismic-hazard assessment, and this Manual describes procedures for performing a seismic-hazard assessment using a DSHA with comparison to published probabilistic hazard assessments, such as those available from the USGS or the USNRC. The MCE should be shown to be an extremely remote event. FEMA (2005b) indicates that a PSHA can aid in deciding whether mean, or mean-plus-one-standard-deviation, or even greater estimates of ground motion are justified in a deterministic ground motion analysis for the MDE to achieve an acceptably low probability of exceedance. Until published guidance from federal dam safety agencies is available, the designer should consider that for high-hazard-potential facilities in areas of medium to high seismic hazard, the primary role of a PSHA is to serve as technical support in the selection of an MCE consistent with FEMA (2005b).

The OBE, as well as the MDE for significant-hazard-potential dams, can be defined on the basis of a probabilistic analysis, which could simply be obtained from published results of the USGS. As noted in the introduction to this chapter, a probabilistic analysis considering a 500-year return period can serve as the basis for defining an OBE, and a return period of the order of 2,500 years may be reasonable for establishing the MDE for a significant-hazard-potential dam.

Another means for evaluation of the results of a DSHA is to review the design basis for nuclear power plants, which have all been designed on the basis of a DSHA. The location of nuclear power plants with respect to U.S. coal fields is presented in [Figure 7.22](#). [Table 7.7](#) provides the Safe Shutdown Earthquake (SSE) peak horizontal ground accelerations (PGA) that formed the basis for seismic design for each nuclear plant. The SSE PGA values for these nuclear plants should be considered as minimum values for a MCE. The conservatism associated with the seismic input for a nuclear power plant has proven to be the overall spectral shape of their seismic input, rather than the PGA. Furthermore, earthquake magnitude values associated with the SSE are generally not defined, because the practice for defining seismic hazard in the 1960s and 1970s, when these nuclear power plants were licensed, was to base the design on Modified Mercalli intensity (MMI) relationships.

As noted in [Section 7.7.2](#), much of the areas mined for coal in the central and eastern U.S. have a low seismic hazard. For these areas a simplified approach is recommended for defining a minimum standard for seismic design. [Section 7.7.3.7](#) of this Manual proposes standard seismic inputs for design in areas of low seismic hazard, and these inputs are believed to be reasonably conservative for coal refuse impoundments. If the designer judges that less conservative inputs than recommended herein are appropriate, it is acceptable to perform a complete hazard analysis to justify less conservative project-specific and/or site-specific seismic design inputs. The following sections present more detailed information regarding the definition of design ground motion for an MCE for a high-hazard-potential dam.

7.7.3.1 Selection of Design Earthquakes

The MCE for each seismotectonic structure or source area within the region examined needs to be defined by a common parameter, preferably by moment magnitude M , but in a manner that is compatible with the attenuation function used to derive site ground motion. It is recommended that the maximum historical site MMI be evaluated as an additional estimate to site ground motion, but it is recommended that the historical MMI be converted to magnitude based on scientific evaluations of the ground effects. Such studies are usually available for the most significant historical events. For example, using a new method for evaluating magnitude by directly inverting observations of intensities, Bakun and Hopper (2004) determined a moment magnitude M of 7.4 (7.0 to 7.7 at a 95 percent confidence level) for the largest New Madrid earthquake in the 1811-12 sequence. Scientific publications for evaluation of the magnitude of historical earthquakes are generally available.

Where the earthquake history is incomplete or where there is no geologic evidence regarding past earthquake activity, judgment is required in assigning a maximum magnitude to each source. Where



NOTE: 1. THE SAFE SHUTDOWN EARTHQUAKE (SSE) DESIGN PEAK HORIZONTAL GROUND ACCELERATIONS FOR THESE NUCLEAR POWER PLANTS ARE PROVIDED IN TABLE 7.5.
2. ANTHRACITE AND BITUMINOUS COAL FIELDS ARE DENOTED BY RED BORDERS.

FIGURE 7.22 LOCATION OF NUCLEAR POWER PLANTS WITH RESPECT TO U.S. COAL FIELDS

fault sources are inferred to be present, fault movement within the range of 35,000 to 100,000 years BP is considered recent enough to warrant an “active” or “capable” classification, and they should be modeled as sources according to their fault dimensions and histories. The assignment of a maximum magnitude to each source should consider the concepts presented in [Section 7.7.2.4](#).

The MCEs identified for each source potentially affecting the site are candidates for one or more controlling MCEs at the site. It is also important to look at a variety of earthquakes that have a long duration and are rich in lower frequency contents, but do not necessarily cause the highest peak acceleration at the coal refuse site. For coal refuse impoundments, this longer-duration earthquake may be the controlling event if it triggers strength loss of the embankment/foundation materials. Seismic input for a coal refuse impoundment facility may be defined by both near-field and far-field events. For purposes of clarification, a near-field event is an earthquake that is postulated to have an epicenter at or very near a site of interest and a far-field event is one where the earthquake is not expected to occur near the site.

7.7.3.2 Ground Motion Attenuation

The difference in ground-motion attenuation between the western and eastern U.S. is significant and needs to be accounted for in the hazard analysis. This is a topic that has been extensively researched and there are a number of attenuation functions that have been developed for eastern U.S. ground motion. Examples include Toro et al. (1997), Frankel et al. (1996), Atkinson and Boore (1995, 2006), Somerville et al. (2001) and Campbell (2003). The attenuation relationships were developed based on

numerical modeling and sparse strong-motion records from small earthquakes, and while subject to uncertainty, they are considered to be appropriate.

7.7.3.3 Selection of Peak Ground Motion Parameters

The MCE is defined as the most severe ground motion calculated from the selected ground motion attenuation relationship(s) from the various potential MCEs identified from the possible sources. The credible severe combination(s) of magnitude (preferably moment magnitude) and distance will define the basis for the MCE. The ground motion associated with the credible severe combinations of magnitude and distance is normally defined in terms of peak ground acceleration (PGA).

In many cases the most severe PGA is associated with a relatively small nearby earthquake, especially in the areas of relatively low seismic hazard. Where there is moderate to high risk, just deriving the credible severe PGA from a small local earthquake is not sufficient, and it is necessary to supplement this MCE with a credible severe earthquake from a relatively distant large magnitude source where the PGA might be lower than a small local event, but will be associated with more cycles of ground motion.

7.7.3.4 Selection of Acceleration Time Histories

A time-history representation of the seismic input is generally presented in terms of the ground accelerations (accelerograms) where the variation of ground motion is plotted as a function of time. Actual strong motion recordings of earthquakes are time histories of the earthquake ground motion. Ultimately, the goal of selecting a time history for use in design is to be able to match the MDE ground motion with a PGA and number of cycles of ground motion defined for design. There are two ways to obtain time histories for engineering design and analysis: (1) actual ground motion records or (2) synthetic ground motions.

Actual ground motion records can be obtained from the USGS or COSMOS (Consortium of Organizations for Strong-Motion Observation Systems) web sites. If actual strong motion recordings are used as seismic input, they need to be selected to match as closely as possible the source magnitude and expected faulting mechanism, recognizing that faulting mechanisms may not be known if the site is in the central or eastern U.S. Although distance is a consideration in the selection of the ground motion, it is more significant that the earthquake simulate the PGA derived for the design MDE(s) and that the duration/number of cycles of ground motion be consistent with the number of cycles derived with the simplified approach for liquefaction analysis. In addition, care should be taken to select records that are well represented in the frequency range of interest to an embankment dam (approximately 0.5 to 1.5 Hz). In order to effectively bound the range of possible ground motions, several hypothetical design ground motions, or a synthetic time history rich in all possible frequencies of interest, should be used.

As noted in [Section 7.7.3.2](#), most of the strong motion records available as potential design time histories in the range of a central and eastern U.S. MCE will be from areas with different attenuation characteristics (e.g., the western U.S.). There are very few records from the central and eastern U.S., especially for moderate to strong earthquakes of magnitude M greater than 5.0. Nevertheless, as noted in [Section 7.7.2](#), in spite of the differences associated with western U.S. records and limitations to the eastern U.S. database, these differences can be accounted for in a seismic hazard analysis because, within soils where strength loss occurs, it is expected that western and eastern ground motions will be similar (Youd et al., 2001). If actual strong ground motion records are used as the basis for defining the MCE, it is recommended that at least three records be selected for the analysis and that justification provided for their selection. If the site is in an area of medium to high seismic hazard, more than three time histories should be used.

Although real time histories are the preferred means for defining ground motion, an alternative approach for defining a design time history that is often used in the central and eastern U.S. is to derive

synthetic ground motions. The most widely used methods to generate synthetic ground motion are the stochastic point- and finite-source models (Hanks and McGuire, 1981; Toro and McGuire, 1987) and the stochastic finite-fault model, which can simulate some of the near-source effects (Atkinson and Silva, 1997; Beresnev and Atkinson, 1997). With the improvement of computers, it has become possible to use more sophisticated numerical methods for simulating strong ground motion based on empirical or theoretical source functions and two- and three-dimensional wave propagation theory, which has been successfully used in ground-motion simulations for many earthquakes (Somerville et al., 2001; Saikia and Somerville, 1997). Zeng et al. (1994) also developed a composite source model that has been recommended for use in generating synthetic ground motions for seismic design and analysis of highway bridges in Kentucky.

TABLE 7.7 SAFE SHUTDOWN EARTHQUAKE (SSE) PEAK HORIZONTAL GROUND ACCELERATIONS FOR U.S. NUCLEAR POWER PLANTS

Plant	SSE PGA (g)	Plant	SSE PGA (g)
Arkansas Nuclear 1, 2	0.21	Millstone 2, 3	0.17
Beaver Valley 1, 2	0.13	Monticello	0.13
Braidwood 1, 2	0.19	Nine Mile Point, 1, 2	0.15
Browns Ferry 1, 2, 3	0.21	North Anna, 1, 2	0.13
Brunswick 1	0.17	Oconee 1, 2, 3	0.11
Byron 1, 2	0.19	Oyster Creek	0.27
Callaway	0.19	Palisades	0.19
Calvert Cliffs 1, 2	0.15	Palo Verde 1, 2, 3	0.19
Catawba 1, 2	0.17	Peach Bottom, 2, 3	0.15
Clinton	0.21	Perry 1	0.15
Columbia Generating Station	0.25	Pilgrim 1	0.15
Comanche Peak 1, 2	0.13	Point Beach 1, 2	0.13
Cooper	0.21	Prairie Island 1, 2	0.13
Crystal River 3	0.11	Quad Cities 1, 2	0.27
D.C. Cook 1, 2	0.21	River Bend 1	0.11
Davis-Besse	0.15	Robinson 2	0.19
Diablo Canyon 1, 2	0.80	Saint Lucie 1, 2	0.11
Dresden 2, 3	0.21	Salem 1, 2	0.21
Farley 1, 2	0.11	San Onofre 2, 3	0.63
Fermi 2	0.15	Seabrook 1	0.25
FitzPatrick	0.15	Sequoyah 1, 2	0.17
Fort Calhoun	0.19	South Texas 1, 2	0.11
Ginna	0.19	Summer	0.15
Grand Gulf 1	0.15	Surry 1, 2	0.15
Harris 1	0.15	Susquehanna 1, 2	0.11
Hatch 1, 2	0.15	Three Mile Island 1	0.15
Hope Creek 1	0.19	Turkey Point 3, 4	0.15
Indian Point 2, 3	0.15	Vermont Yankee	0.19
Kewaunee	0.13	Vogtle 1, 2	0.19
La Salle 1, 2	0.21	Waterford 3	0.11
Limerick 1, 2	0.15	Watts Bar 1	0.19
McGuire 1, 2	0.15	Wolf Creek 1	0.13

(ADAPTED FROM SOBEL, 1994)

7.7.3.5 Applicability of Design Ground Motion

The end result of a seismic hazard assessment is to derive the ground motion that will affect the base of the impounding structure. Most ground-motion-attenuation relationships derive motion for bed-rock or stiff (firm) soils. Where the site foundation consists of less stiff/dense or deeper soil deposits, or otherwise deviate from the site conditions for which the attenuation relationships are applicable, the derived ground motion should be applied at the top of rock and the ground motion (at the ground surface) estimated from local site response analyses based on computer simulation with programs such as SHAKE, QUAD4M, or DESRA (Schnabel et al., 1972; Finn et al., 1977). For these analyses it is necessary to use a time history input as discussed in Section 7.5.

7.7.3.6 Application of Seismic Parameters in Design Process

Figure 7.23 presents a flow diagram for seismic hazard assessment to determine the design earthquake inputs (M , PGA, ground motion). At a minimum, the design M and PGA are required, as these data are used in the Youd, et al. (2001) pore-pressure-based triggering analysis, to establish a minimum number of cycles of loading for cyclic shear strength testing, in very simplified dynamic response analyses, and for other general purposes. More rigorous dynamic response, seismic stability, and deformation analyses require design ground motions (acceleration versus time histories) to estimate the amplification or de-amplification of the ground motion from the appropriate input horizon (e.g., top of rock, top of stiff soil, or base of structure), up through the foundation and overlying structure; calculate peak accelerations at critical locations within the foundation and structure; conduct more refined and sophisticated triggering analyses; calculate seismically-induced stresses and strains; and identify the likely modes and estimate the range in magnitude of deformation.

7.7.3.7 Simplified Design Ground Motion for Areas of Low Seismic Hazard

As noted in the introduction to Section 7.7.3, a substantial portion of the areas mined for coal in the central and eastern U.S. have a low seismic hazard. The definition of what constitutes low seismic hazard is judgmental, but coal refuse disposal facilities in the area where the *Documentation for the 2002 Update of the National Seismic Hazard Map* (Frankel et al., 2002) indicates that the PGA with a return period in 2,500 years is less than or equal to 0.10g can be considered to be representative of low seismic hazard (Figure 7.19). This zonation is effectively similar to the area where the return period for an earthquake of $M > 5.5$ within 50 km of a given location is greater than 10,000 years (Figure 7.21).

For structures in areas of low seismic hazard that warrant evaluation for a MCE, a simplified approach can be used. The simplified minimum design earthquake should have a moment magnitude M of at least 5.5 ($M \geq 5.5$) at a distance no farther than 50 km from the source. For evaluations of triggering or deformations requiring both M and PGA, adopt 150 percent of the PGA associated with a 2,500-year return period based on the USGS PSHA hazard maps, but not less than $PGA = 0.10g$. When needed, select earthquake ground motion records based on M and the other considerations outlined in Section 7.7.3.4. In areas of low seismic hazard, it is not necessary to consider more distant earthquakes with $M > 5.5$.

Commentary: A simplified approach is recommended by the authors to define a minimum standard for seismic design in low-seismic-hazard areas, with inputs believed to be reasonably conservative for coal refuse impoundments. It is based on published seismic hazard mapping, subject to periodic updating and widely available from the USGS. Based on the project site location, a designer can directly determine the M and PGA using the above procedures for the simplified minimum design earthquake. If a designer judges that other (or potentially less conservative) inputs are appropriate, it is acceptable to perform a seismic hazard assessment. As indicated in Table 7.6, the minimum standard is appropriate for projects only in low-seismic-hazard areas, and a seismic hazard assessment is necessary in moderate to high seismic hazard areas.

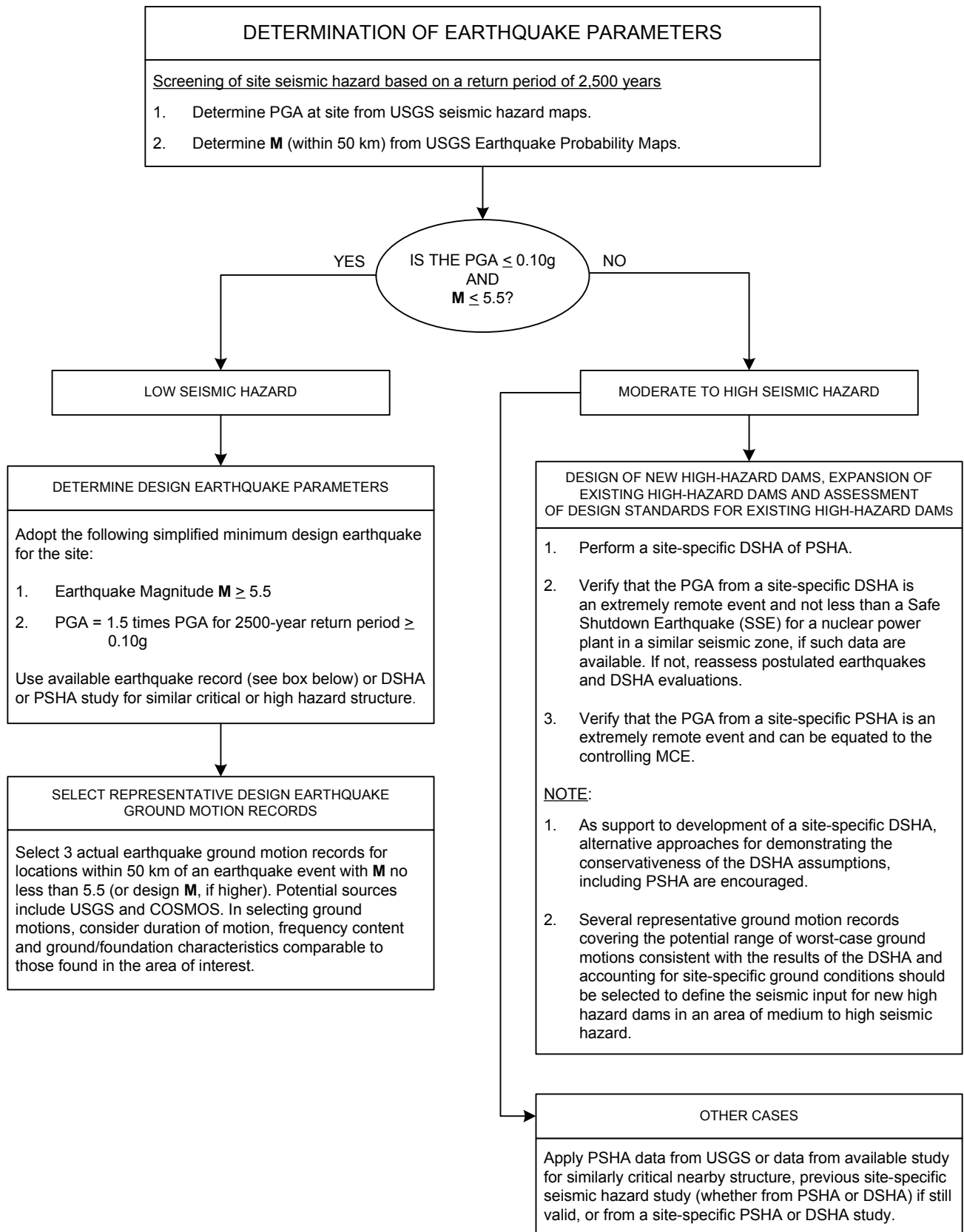

FIGURE 7.23 SEISMIC HAZARD ASSESSMENT FLOW DIAGRAM

Selection of time histories of acceleration for structures in areas of low seismic hazard should consider earthquake records that are reflective of the site-specific design parameters (M and PGA) and foundation conditions. Attributes of the time histories of acceleration should include: (1) the M and PGA are at least equivalent to the site-specific design parameters, (2) near-field event with hypocentral distance of 50 kilometers or less, (3) foundation conditions similar to site-specific conditions (otherwise, some adjustment of the time history may be warranted), (4) several cycles with a representative band of acceleration in proportion to the design PGA, and (5) some cycles at or near the frequencies of interest for the structure (low frequencies for dams). [Section 7.7.3.4](#) presents reference sources for ground motion histories. The following time histories illustrate the selection of candidate records for low-seismic-hazard areas:

- [Example 1 \(Figure 7.24\)](#) – Time history for low-seismic-hazard area, and the site is distant from widely recognized seismic source zones. This example illustrates a time history that can be considered for a site in the eastern or central U.S., with a design M and PGA of at least 5.5 and 0.1g, respectively. This example has a high PGA (much greater than the site specific design PGA) and lacks cycles of substantive acceleration at lower frequencies, which is not uncommon.
- [Example 2 \(Figure 7.25\)](#) – Time history for low-seismic-hazard area, but the site is close to a boundary of moderate seismic hazard (as reflected by a site-specific PGA much greater than 0.1g). This example illustrates a time history that may be considered for a site in the eastern or central U.S. (close to a recognized seismic source zone) with a design M of at least 5.5 and a design PGA much greater than 0.1g (e.g., 0.12 to 0.15g) with significant low frequency content. This example could also be conservatively applied to sites in low-seismic-hazard areas that are distant from widely recognized source zones.
- [Example 3 \(Figure 7.26\)](#) – Time history for low-seismic-hazard area, and the site is distant from widely recognized seismic source zones. This example illustrates a time history for an actual eastern North American earthquake that could be considered for a low-seismic-hazard site in the eastern US.

7.8 SEISMIC DESIGN OVERVIEW

Gardner and Wu (2002) presented an overview of the challenges in evaluating strength loss and seismic stability at coal refuse disposal facilities, including a summary of available pore-pressure-based empirical methods and strain-based laboratory methods that MSHA has used in their review and approval of impoundment plans. Wu et al. (2003) cite common MSHA review issues with seismic stability including: (1) defining materials subject to strength loss, (2) sampling and testing protocols, (3) defining ground motion parameters applicable to the site, (4) determining the appropriate margin of safety, (5) and dealing with questions concerning the applicability of available technical information for fine coal refuse. There are no documented case histories of a fine coal refuse impoundment being affected by significant earthquake loading, and as a result, there is little direct confirmation of methods that have been employed for estimating strength loss. Thus, MSHA has been faced with reviewing impoundment design plans with minimal factors of safety, often without mitigating design features that would enhance seismic stability such as provisions for internal drainage of fine refuse deposits.

This chapter has presented credible, documented methods and procedures for the evaluation of seismic design including stability and deformation analyses considered applicable for materials encountered at coal refuse disposal facilities. A flow chart illustrating the steps involved in evaluating seismic design, stability and deformation was presented in [Figures 7.1a, 7.1b](#) and [7.1c](#), and [Section 7.1.2](#) provides a discussion of the basis for the design guidance, including:

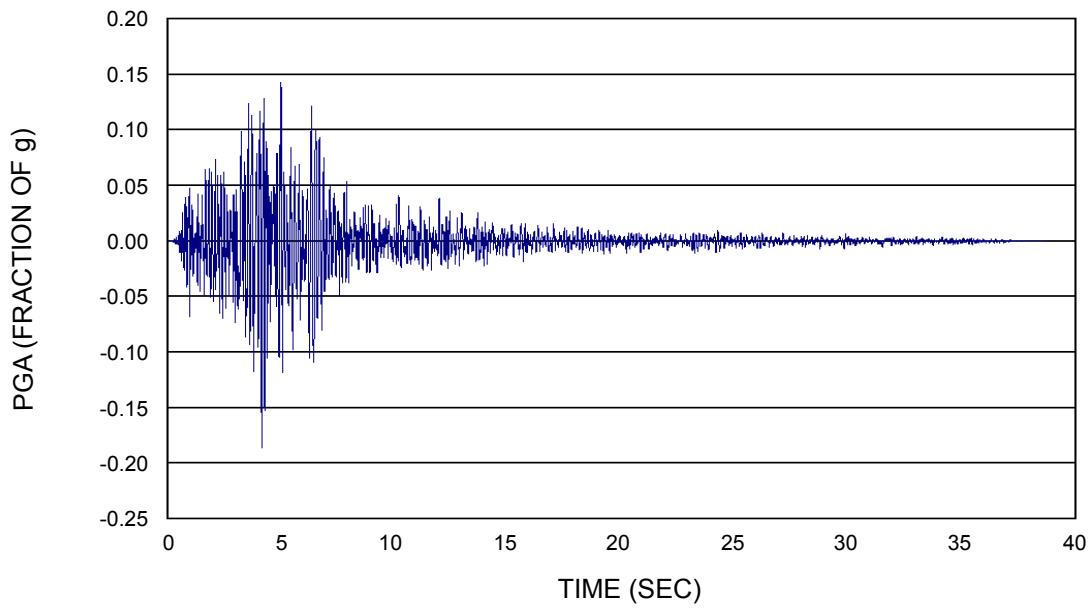

7.24a OVERALL RECORD

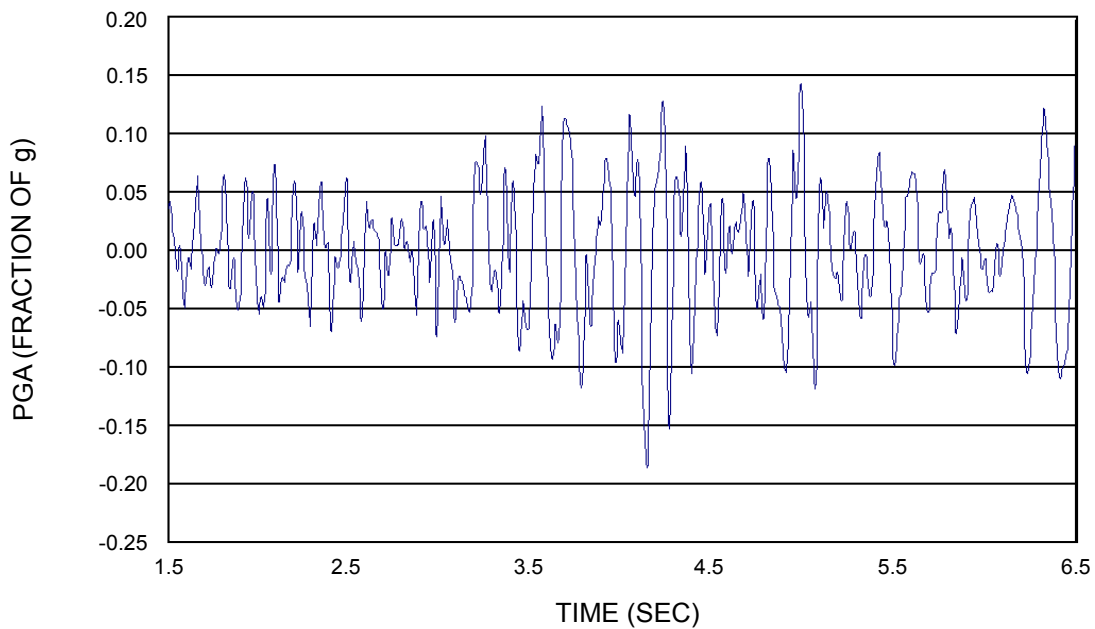

7.24b SAMPLE TIME SEGMENT

WHITTIER NARROWS - STATION: 24399 MT. WILSON - CIT SEISMIC STATION
 OCTOBER 1, 1987 $M = 5.99$, DISTANCE FROM FAULT RUPTURE = 21.2 KM, $V = 822$ M/SEC (ROCK)

- ATTRIBUTES:
1. M AND PGA > SITE-SPECIFIC DESIGN M AND PGA
 2. NEARER FIELD, FAULT-DRIVEN EVENT WITHIN 50 KM
 3. FIRM ROCK COMPARABLE TO PROJECT SITE CONDITIONS
 4. MANY CYCLES WITHIN REPRESENTATIVE BAND OF PGA.
 5. LIMITED CYCLES AT LOWER FREQUENCY.

NOTE: SITE IS DISTANT FROM WIDELY RECOGNIZED SEISMIC SOURCE ZONES

(UNIV. OF CAL., 2007a)

FIGURE 7.24 EXAMPLE 1: TIME HISTORY FOR LOW-SEISMIC-HAZARD AREA

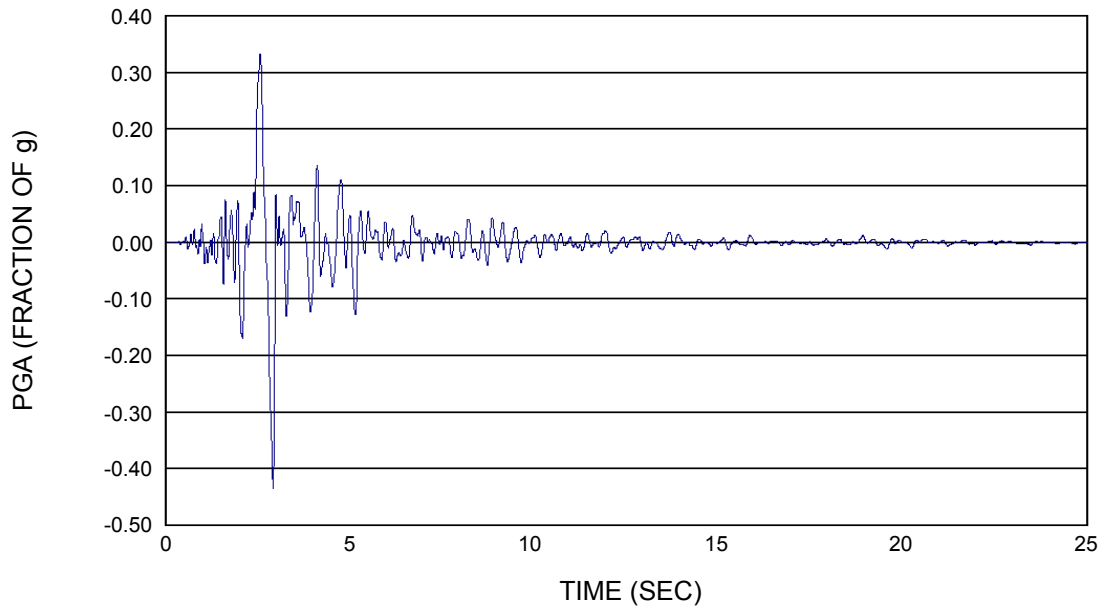

7.25a OVERALL RECORD

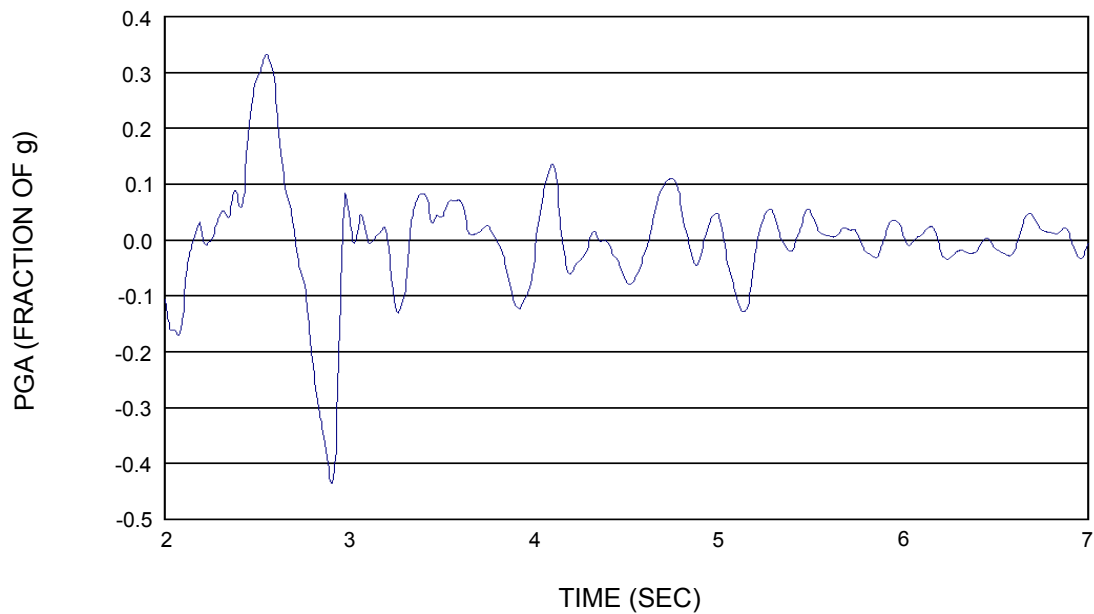

7.25b SAMPLE TIME SEGMENT

COYOTE LAKE - GILROY ARROY #6, 230 (CDMG STATION 57383)
 AUGUST 6, 1979 $M = 5.7$, HYPOCENTRAL DISTANCE = 9 km, $V = 663$ m/sec (SOFT ROCK)

- ATTRIBUTES:
1. M AND PGA > SITE-SPECIFIC DESIGN M AND PGA
 2. NEAR FIELD EVENT MUCH CLOSER THAN 50 km
 3. SOFT ROCK COMPARABLE TO PROJECT SITE CONDITIONS
 4. INCLUDES PERTINENT LOW FREQUENCY CYCLES.
 5. SIGNIFICANT ACCELERATION SPIKES AT LOWER FREQUENCY.

NOTE: SITE IS CLOSE TO THE BOUNDARY OF MODERATE SEISMIC HAZARD

(UNIV. OF CAL., 2007b)

FIGURE 7.25 EXAMPLE 2: TIME HISTORY FOR LOW-SEISMIC-HAZARD AREA

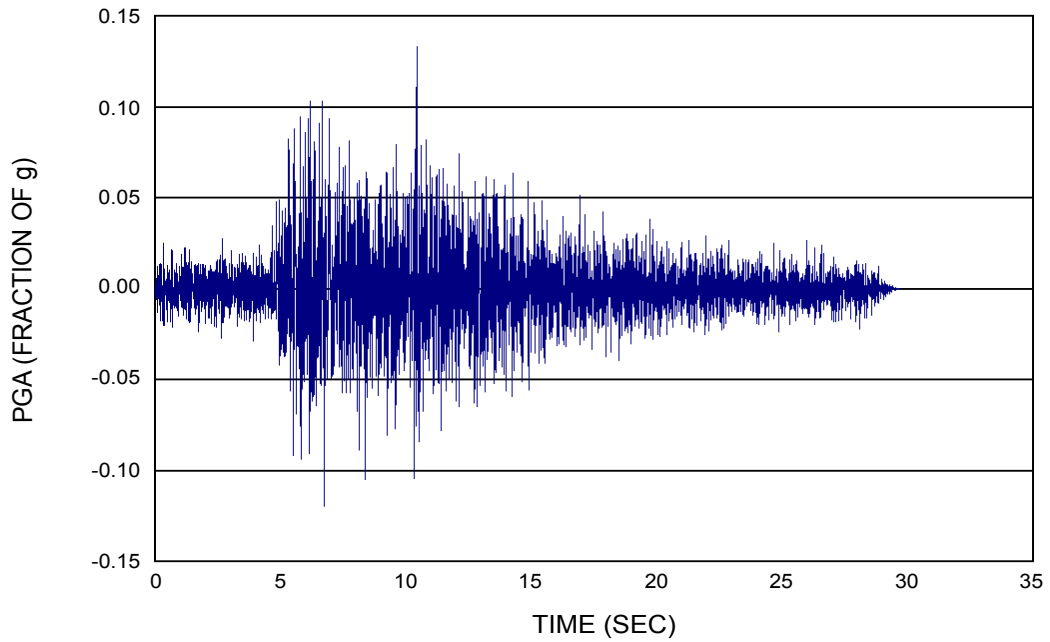

7.26a OVERALL RECORD

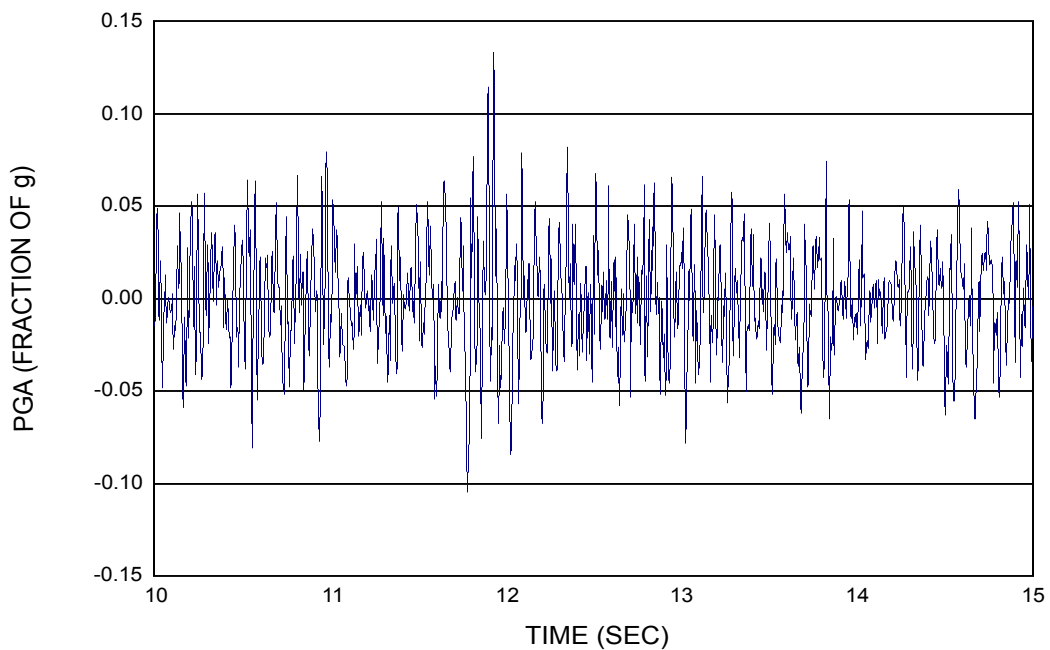

7.26b SAMPLE TIME SEGMENT

SAGUENAY - W. CHICOUTIMI NORD (SITE 16 T)
 NOVEMBER 25, 1988 **M** = 5.9, HYPOCENTRAL DISTANCE = 50 KM (HARD ROCK)

- ATTRIBUTES:
1. **M** AND PGA > SITE-SPECIFIC DESIGN **M** AND PGA
 2. EASTERN NORTH AMERICA
 3. ROCK RECORD
 4. MANY CYCLES WITHIN REPRESENTATIVE BAND OF PGA
 5. RELATIVELY LONG DURATION OF STRONG SHAKING > 0.05g (~12 SEC)

NOTE: EASTERN U.S. EARTHQUAKE, DISTANT FROM WIDELY RECOGNIZED SEISMIC SOURCE ZONES

(UNIV. OF CAL., 2007c)

FIGURE 7.26 EXAMPLE 3: TIME HISTORY FOR LOW-SEISMIC-HAZARD AREA

- Appropriate levels of analysis, depending on the type of facility.
- Methods for identifying and evaluating material susceptibility to strength loss, including available field and laboratory techniques.
- Simplified methods for estimating post-earthquake strength, as well as more sophisticated methods for evaluating if triggering of strength loss occurs.
- Alternatives for evaluating seismicity depending on the level of seismic hazard of the region.
- A recommended factor of safety for seismic stability of 1.2 based on a static stability analysis using post-earthquake strengths, which also helps achieve designs with predicted deformations within acceptable limits.

Section 7.1.5 provides recognized, simplified steps and procedures that utilize basic site data and component material properties for development of conservative embankment dam designs in regions of low seismic hazard that constitute most of the areas of coal mining, as discussed in Section 7.7. More sophisticated analyses and procedures may be needed for some facilities built by upstream construction, and these are also discussed in Section 7.1.5, with additional details presented in Section 7.4. These more sophisticated analyses and procedures can reduce conservatism and potentially provide the experienced designer with more expertise additional options for design. These types of analyses may be needed in those limited regions where seismic hazard is moderate to high. Basic screening methods for evaluating deformations are discussed in Section 7.1.5, and the applicability of both screening and analysis procedures is presented in Section 7.5.

Other credible methods and procedures may be acceptable or may become accepted in practice, provided that documentation and testing support their application, and these methods should not be precluded from use in seismic design.

Appendix 7A

DERIVATIONS OF BASIC EQUATIONS FOR STEADY-STATE LABORATORY TESTING

7A.1 COMPARISON OF α AND ϕ ENVELOPES AT STEADY STATE

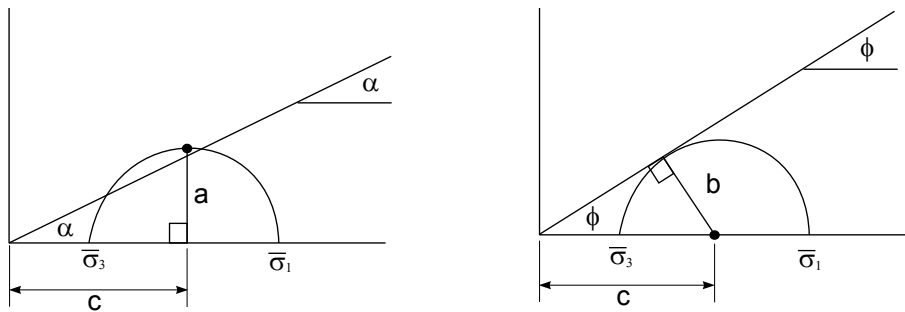

MOHR'S CIRCLE AT STEADY STATE

α ENVELOPE DRAWN THROUGH MAXIMUM SHEAR STRESS ON MOHR'S CIRCLE

ϕ ENVELOPE DRAWN TANGENT TO MOHR'S CIRCLE

DEFINE $\bar{p} = \frac{\bar{\sigma}_1 + \bar{\sigma}_3}{2}$ MEASURED IN TRIAXIAL TEST AT STEADY STATE

DEFINE $q = \frac{\bar{\sigma}_1 - \bar{\sigma}_3}{2}$ MEASURED IN TRIAXIAL TEST AT STEADY STATE

$$a = b = q$$

$$c = \bar{p} = \bar{\sigma}_3 + q$$

$$\tan \alpha = \frac{a}{c}$$

$$\sin \phi = \frac{b}{c}$$

$$a = b$$

THEREFORE $\sin \phi = \tan \alpha$

AND $\phi = \sin^{-1} \left(\frac{q}{\bar{p}} \right)$

7A.2 RELATIONSHIP BETWEEN S_{US} AND σ_3 AT STEADY STATE

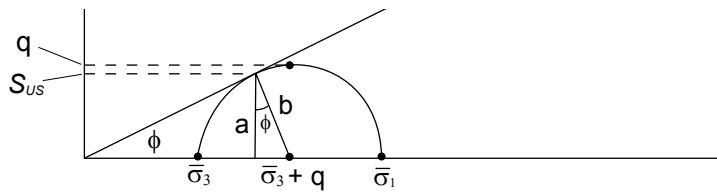

MOHR'S CIRCLE AT STEADY STATE

$$b = q = \frac{\bar{\sigma}_1 - \bar{\sigma}_3}{2} = \text{RADIUS OF MOHR'S CIRCLE}$$

$$a = b \cos \phi = S_{US}$$

THEREFORE: $S_{US} = q \cos \phi$

FROM TRIANGLE GEOMETRY: $\sin \phi = \frac{b}{\bar{\sigma}_3 + q} = \frac{q}{\bar{\sigma}_3 + q}$

$$\sin \phi = \frac{\frac{S_{US}}{\cos \phi}}{\bar{\sigma}_3 + \frac{S_{US}}{\cos \phi}} = \frac{S_{US}}{\bar{\sigma}_3 \cos \phi + S_{US}}$$

$$\bar{\sigma}_3 \cos \phi \sin \phi + S_{US} \sin \phi = S_{US}$$

$$\bar{\sigma}_3 \cos \phi \sin \phi = S_{US} (1 - \sin \phi)$$

THEREFORE: $\bar{\sigma}_3 = S_{US} \left(\frac{1 - \sin \phi}{\cos \phi \sin \phi} \right)$

Appendix 7B

VOID-RATIO MEASUREMENTS DURING UNDISTURBED TUBE SAMPLING AND LABORATORY TESTING

7B.1 INTRODUCTION

The purpose of this appendix is to present methods for accurate measurement of the void ratio of triaxial specimens and the changes in void ratio of undisturbed tube samples from conditions in situ to conditions during shear in the triaxial test. Accurate void ratio measurements are needed in order to correct the undrained steady-state (residual) strengths measured in the triaxial test to obtain in-situ strengths using the procedures described in Poulos et al. (1985). Specifically, the required void-ratio values are:

- Undisturbed specimens – both the void ratio in situ and the void ratio during undrained shear in the triaxial test must be determined. To obtain these values one measures the void ratio changes that occur at various stages of the sampling and testing process, as subsequently discussed.
- Remolded specimens (tested to obtain the slope of the steady-state line) – the actual void ratio in the triaxial cell during shear is needed. For drained tests, the void ratio changes during shear, and the value when the specimen reaches steady state is needed.

In the discussion that follows, undisturbed specimens are addressed first, and then the differences in the procedures for remolded specimens are presented. The procedures discussed below include some measurements that are not directly needed in the Poulos et al. (1985) procedure. However, these extra measurements provide important checks of the measurements that are directly needed. These procedures relate to soils ranging from slightly silty sands to slightly clayey silts. Note that, in this appendix, the term “sample” is used to refer to an entire tube sample obtained from the field. The term “specimen” refers to a portion of the sample trimmed from a tube or prepared in the laboratory.

7B.2 USE OF AVERAGE VOID RATIO

In all cases it is assumed that the average void ratio of the entire specimen during shear is representative of the strengths and pore-pressure measurements being made in the triaxial test. If localized shear straining develops, as evidenced by shear planes or localized bulging, this assumption is no longer valid because the average void ratio of the specimen is no longer representative of the soil being sheared. Tests with shear planes or localized bulging cannot be used unless localized measurements of void ratio are carried out using esoteric techniques such as impregnation with resins followed by microscopic examination.

Similarly, tests on specimens with significant stratification within the specimen (e.g., layers of slightly silty sand alternating with layers of slightly clayey silt) cannot be used, because the average void ratio is not representative of either soil type. Past experience with coal refuse indicates that careful

selection of sampling zones based on CPT data has resulted in stratification not being an issue and not causing concentration of deformations in any zone within the test specimen.

7B.3 UNDISTURBED TUBE SAMPLING

Sampling in borings can be accomplished using a thin-wall tube (3-inch O.D. with wall thickness of one-sixteenth inch) with either a fixed-piston sampler with piston rods extending to the ground surface (Hvorslev sampler) or a hydraulically-actuated piston sampler (Gus or Osterberg sampler). Hand-carved samples can be obtained in test pits using a tripod tube sampler. Detailed sampling procedures for the Hvorslev sampler are presented in Appendix 7C. Similar procedures should be used for other samplers.

High quality galvanized-steel, brass, or stainless-steel tubes should be used. The cutting edge should have a clearance ratio of between 0.5 and 1.0 percent ([Appendix 7C](#)) and should be filed sharp and smooth immediately prior to use.

Measurements required during sampling are:

- Sampler penetration into the material (to the nearest millimeter).
- Length of recovered sample (to the nearest millimeter).
- Inside diameter of the sample tube cutting edge (to nearest 0.1 millimeter, using calipers).
- Inside diameter of the sample tube (to nearest 0.1 millimeter, using calipers).

The volume change during sampling is computed from:

- In-situ sample volume = distance pushed times tube area at cutting edge
- In-tube sample volume = sample length recovered times inside area of tube

When measuring the length recovered, it is expected that the bottom of the sample is flush with the bottom of the tube. If a section of the bottom of the sample is missing, it can be assumed that it fell during withdrawal of the sampler from the borehole and thus should be considered to be part of the measured length recovered.

There are potential errors in this part of the procedure. In general, the errors overstate any decrease in volume. For example, the sample may be flush with the bottom, but may have slid downwards. The shorter measured recovery would be assumed to be a volume decrease with an associated decrease in void ratio, which is conservative in the overall estimation of in-situ strengths. However, very large apparent void ratio decreases should be considered unreasonable, and the sample should not be used for testing.

Experience indicates that it is possible to keep volume changes during sampling generally below one percent, with the change being usually in compression, but some slightly clayey silts may actually expand slightly during sampling.

After the length of recovered sample is measured, a section of the sample at the bottom should be removed to allow installation of the packer. The tube should be maintained in an upright position at all times. The packer may have drain holes to allow drainage in sands, but should be solid for soils exhibiting any plasticity. The top should be cleaned and a loose packer or other disk placed on top of the sample. The distance from the top of the tube to the disk should then be accurately measured. This measurement should later be rechecked to determine if the sample settled during transport.

7B.4 HANDLING AND TRANSPORTATION

Sample tubes must be kept upright at all stages of handling and transportation. The tubes should be transported in private vehicles and cushioning should be provided around each tube and between the tube rack and the vehicle to minimize the transmission of vibrations from the vehicle to the samples. Freezing of the samples must be avoided. Any volume change that occurs during handling and transportation can be computed as the change in vertical distance from the top of the tube to the top of the disk resting on the sample. Volume changes that occur during transportation and handling are normally negligible even for sand, if reasonable care is taken.

7B.5 TUBE CUTTING AND EXTRUSION

Tube cutting must be performed using a method that does not produce vibration or deformations of the sample tube. Typically a tube cutter is used. Low pressure is applied to the tube, and stiffener rings are placed above and below the cut to minimize tube deformation. The tube must be maintained in a vertical position. The distance to the top of the sample will indicate if volume changes have occurred. If the described procedure is carefully followed, the volume changes during tube cutting should be negligible.

After the tube section containing the triaxial test specimen is cut, the ends of the specimen are typically trimmed away from each end of the tube section by about one-half inch, so that: (1) the ends of the tube section can be deburred and (2) a packer can be installed in the tube to keep the sample in place. The following measurements should be made:

- Total weight of the sample and tube (this is a back-up measurement)
- Length of tube section – length of the tube minus the distance from each end of tube to the ends of specimen (all measurements to the nearest 0.5 millimeter; each measurement should be the average of three points taken around the circumference of the tube).
- Inside diameter of the tube section (to the nearest 0.1 millimeter, using calipers).

The volume of the specimen in the sample tube after cutting and trimming can be computed from the above measurements.

From this point on, all soil in the tube section must be recovered and the dry weight measured. This requires that extreme care be taken because: (1) some soil will stick to the sample tube during extrusion, (2) some will stick to the membrane after triaxial shear, and (3) some will be used for index testing after the triaxial shear testing is performed. The total dry weight of soil, encompassing all of the above, and the measured volume of the specimen should be used to compute the void ratio.

The specimen must be extruded upward from the tube, i.e., in the same direction that it entered the tube during sampling. During extrusion, any soil that stuck to the tube and any other soil that for whatever reason did not make it to the triaxial cell must be recovered.

Depending on the ability of the soil sample to stand vertically, it may need to be extruded directly into a close-tolerance membrane stretcher using a membrane that is then used to transfer the sample to the triaxial cell pedestal. A small vacuum may need to be applied to the sample to complete placement of a second membrane and attachment of the drainage lines to the top cap. Membrane thicknesses should be measured prior to use. After the sample is safely in the triaxial cell under a small vacuum, measurements of sample length and diameter should be made, with the latter requiring correction for membrane thickness. Note that these are backup measurements.

7B.6 SATURATION

Once the triaxial cell is assembled, a cell pressure must be applied at the same time that the vacuum is released so that the effective stresses in the specimen remain about constant. As the vacuum is released, some water may enter the specimen as air bubbles are reduced in size, but this does not mean that there was a volume change.

Backpressure should then be applied keeping the effective confining stress constant. Note that the process must be done very slowly so that: (1) the backpressure is equalized at all times throughout the sample and (2) the pressure regulators are keeping up with the required pressures. The water that enters the specimen in this process does not correspond to a volume change but to compression of air bubbles in the voids of the soil and eventually their solution into the pore water. For undisturbed samples obtained below the water table, the volume change due to saturation should be negligible. For remolded specimens prepared at low water contents, there may be a collapse due to saturation and a substantial volume change, particularly for silts or very silty sands.

7B.7 CONSOLIDATION

Volume change during consolidation of the saturated specimens can be accurately determined from the water expelled from the samples. If the loading piston is attached to the top cap, height change measurements can also be made accurately, provided that an axial load is applied to the piston to compensate for the upward force in the piston caused by the cell pressure (in order to maintain the desired consolidation stress ratio – typically one). It is advisable to consolidate the sample in stages so that a compression curve (e versus $\log p$) can be obtained. Comparison of compression curves among the various tests can be used as a means of judging unusual results. The changes in void ratio during the consolidation phase are by far larger than for any of the other stages including sampling, transportation, and extrusion.

7B.8 SHEAR AND DISASSEMBLY OF TRIAXIAL CELL

Since undisturbed samples are usually sheared undrained, there is no volume change during shear of saturated samples.

The procedure for disassembling the triaxial cell and removing the sample at the end of a test should allow for two key measurements, namely the water content and the dry weight of the full specimen. The specimen should be sliced in half longitudinally, and any stratification should be noted. A vertical slice should be taken for specific gravity measurement. For coal tailings, a specific gravity measurement should be made for every test specimen. For natural soil, 2 or 3 measurements should be adequate for a given soil layer. Other vertical slices may be taken for Atterberg-limits, grain-size, or hydrometer tests, but at least half of the specimen should be used for the water content measurement. The wet weight of the water content specimen should be measured quickly, before it begins to dry.

As mentioned above, all soil from the triaxial specimen must be recovered so that the full dry weight can be determined. This includes the soil used for index testing, soil stuck to the membrane or end caps, and any other soil trimmings. The wet weight of the water content specimen should be measured to the nearest 0.01 gram. The dry weight of the water content specimen and of all other material from the triaxial specimen and from the specimen removed during tube trimming should also be measured to the nearest 0.01 gram.

To make the test specimen firmer during disassembly of the triaxial apparatus, it may be desirable to reconsolidate the specimen at the end of the test, but, if this is done, the amount of water expelled during reconsolidation must be recorded. The water expelled during reconsolidation must be included in the computation of the water content of the specimen during shear.

7B.9 COMPUTATIONS OF VOID RATIO

Void ratio computations are discussed in the following text and are summarized in [Table 7B.1](#). The following notation is used in the table:

W_s	dry weight
D	diameter
H	height or length
V	volume
w	water content
e	void ratio
γ	unit weight
γ_w	unit weight of water
G_s	specific gravity of soil grains
Δ	incremental change

Stages of sampling and testing are noted by the following:

is	in situ
t	in tube after sampling
tt	in tube after transportation
ts	in tube section after cutting the sampling tube and trimming the ends of the test specimen
txi	in triaxial cell – initial condition under small vacuum
txc	in triaxial cell – after consolidation and during undrained shear

The required values of void ratio are:

- Void ratio during shear in the triaxial cell
- Void ratio in situ

The void ratio during triaxial shear is computed simply from the measured water content of the specimen at the end of the test, using the relationship $G_s w = e$ (assuming 100 percent saturation). As mentioned previously, for coal tailings a specific gravity measurement should be made for every test specimen. For natural soil, 2 or 3 specific-gravity measurements should be adequate for a given soil layer.

Sampling, transportation and tube cutting can result in changes in void ratio from the in-situ condition that can be determined directly from the measured changes in volume, using the formula:

$$\Delta e / (1 + e) = \Delta V / V$$

Changes in void ratio should be averaged for the full tube sample. Subsequent to tube cutting, volume changes and resulting void ratio changes are associated with the tube section from which the triaxial specimen is extruded.

The table at the end of this appendix lists the measured and computed quantities considered to be the primary values, the formulas used, and the secondary values that can be used to compare with the primary measured or computed values. The primary measured and computed quantities should

TABLE 7B.1 VOID RATIO MEASUREMENT FOR UNDISTURBED TUBE SAMPLES⁽¹⁾

Stage	Volume (V)	Dry Weight (W_s)	Void Ratio (e)	Comments
1. In situ Change	ΔV (meas.)		$e(is)$ ↑ Δe (2) ↑	$e(is) = e(t) + \Delta e$ (during sampling) Measure ΔV from V (sampled) versus V (recovered). Compute Δe .
2. Full tube after sampling Change	ΔV (meas.)		↑ $e(t)$ ↑ Δe (2) ↑	$e(t) = e(tt) + \Delta e$ (during transport) Measure ΔV from the height change of the sample during transport between the field and the laboratory
3. Full tube after transport, but before cutting Change	ΔV		↑ $e(tt)$ ↑ Δe (2) ↑	$e(tt) = e(ts) + \Delta e$ (during cutting) Measure ΔV from the height change of the sample measured during tube cutting. ΔV is normally zero. Compute Δe (normally zero).
4. Tube section after cutting and trimming Change	$V(ts) \rightarrow \rightarrow \rightarrow$	$W_s(ts) \rightarrow \rightarrow$ ↑ ↑ ↑ ↑ ↑ ΔW_s	↑ $e(ts)$ (3)	Measure $V(ts)$ from the I.D. of the tube and sample length. Compute $e(ts)$ for $V(ts)$ and $W_s(ts)$. From this point on, all solids should be saved so that $W_s(ts)$ can be measured. The sample in the tube section should also be weighed. This can later be used to estimate the water content and saturation of the sample at this stage. ΔW_s is the soil left in the tube during extrusion.
5. In triaxial cell, following extrusion from tube Change	$V(txi)$ (meas.) $V(txi)$ (comp.) ↑ ↑ ↑ ΔV	↑ $\approx W_s(txi)$ $= W_s(txi)$	$e(txi)$ (3)	$V(txi)$ (meas.) is from measurements of triaxial sample when set up in the cell under small vacuum. $V(txi)$ (comp.) is from $V(txc)$ and ΔV during consolidation. Large differences between the two indicate a potential problem. ΔV is measured during consolidation.
6. In triaxial cell after consolidation and during undrained shear	↑ $V(txc)$ (3,4) ← (Not necessarily needed, but good practice.)	$W_s(txc) \rightarrow \rightarrow$ $w(txc)$ (Computation starts after above are measured.)	$e(txc)$ (4)	Use w and G_s after test (txc) to compute consolidated as-tested void ratio, considering that the sample is saturated at this point. This is the primary method for obtaining $e(txc)$. Also measure W_s for the entire sample. W_s is needed for computation of $e(ts)$ in Stage 4. W_s may also be used to obtain $V(txc)$. $V(txc)$ and ΔV measured during consolidation can then be used as a check on $V(txi)$.

Note: 1. Measurement of ΔV are made from Stage 1 onward, as sampling and testing proceed. The arrows indicate the order of void ratio computations. Computations begin following measurement of $W_s(txc)$ and $w(txc)$ in Stage 6. Computations proceed along the path of the arrows.

$$2. \Delta e = (1 + e) \Delta V / V$$

$$3. e = (G_s \gamma_w V / W_s) - 1$$

$$V = W_s (1 + e) / (G_s \gamma_w)$$

$$4. e = G_s w \text{ (} w \text{ is in percent, assumed to be 100 corresponding to complete saturation.)}$$

be used for estimating in-situ strengths. However, there may be cases where comparison of primary and secondary quantities may indicate that the secondary quantities are more believable and should be used. Some measurements mentioned in the text are not included in the table, but they can also be used to compare to the primary values.

As previously discussed, consolidation should be performed in stages. However, for clarity, consolidation is treated as a one-stage process in the table.

7B.10 REMOLDED SAMPLES

The purpose of testing remolded samples prepared at various void ratios from a uniform batch of soil is to determine the steady-state line for the soil batch, the slope of which is needed for correcting the results from testing of the undisturbed samples. Thus, primarily, we are interested in the void ratio during shear, i.e., the last line in [Table 7B.1](#). However, in planning the tests one targets specific after-consolidation void ratios and confining pressures at which to perform tests so as to achieve sufficiently wide coverage of void ratio and stresses in the steady-state plot. For this purpose, it is important to develop the compression curves for each test (by consolidating in stages) and also to estimate void ratio changes, if any, that would be expected upon saturation.

Assuming that the samples are prepared in a mold of known volume, the process of computing void ratios at various stages is similar to the one shown in the table for undisturbed samples, except that it starts at the “tube section after trimming” stage, which is equivalent to an “in the compaction mold stage” for the remolded samples.

Often when samples are compacted at relatively low water contents, there is substantial compression upon saturation. Thus the volume change from the t_{xi} to the t_{xc} stage includes not only the effect of consolidation, but also the effect of saturation. Since saturation would occur under backpressure, it would occur with the cell assembled, and thus there would not be access to the sample to measure its height and diameter after saturation but prior to consolidation. An alternative procedure would be to cause near-saturation by circulating de-aired water very slowly through the specimen with vacuum applied at the upper end while slightly opening the lower valve to allow the de-aired water to be sucked in, but not opening the valve so much that the vacuum is lost at the lower end of the sample. This process will not result in full saturation, but it will cause collapse and thus allow measurement of the sample prior to cell assembly and the application of cell and backpressures.

Appendix 7C

PROCEDURE FOR UNDISTURBED, FIXED-PISTON SAMPLING OF COHESIONLESS SOIL

The procedures presented herein have been developed for a fixed-piston sampler with piston rods (actuating rods) that extend up to the ground surface (often referred to as a Hvorslev sampler). Similar procedures should be employed for sampling using hydraulically-actuated samplers or tripod-tube samplers.

7C.1 ADVANCING THE HOLE

7C.1.1 General

1. The hole should be started as close to vertical as possible. This is necessary because the actuating rods will be placed through a bracket 10 feet directly above the borehole. If the hole is not vertical, the actuating rods will bend. Also, when the drill rods are pushed, they may slip off the drill head if they are not vertical.
2. The drill head should be almost all the way forward when starting the hole. This allows for maximum horizontal travel of the head. Usually, drillers will do this as routine procedure.

7C.1.2 Casing

1. It is best to use 4-inch-I.D. casing. If larger-diameter casing is used, the velocity of the drill fluid return is reduced, which increases the amount of coarse wash in the borehole. If the casing is smaller, the sampler will be a tight fit. Either flush-joint casing or hollow-stem augers can be used depending on soil conditions.
2. In general, the casing should be advanced to within about 1 foot of the proposed sampling depth. However, this may not be necessary if thick drilling fluid is used and the borehole remains open below the casing. This is referred to as "open-hole" drilling. If Revert drilling fluid is used in open-hole drilling, it is prudent to advance the casing to the bottom of the borehole at the end of the work shift.

7C.1.3 Drilling Fluid

1. It is generally best to use a drilling fluid that has a high unit weight, such as bentonite mixed with water, rather than plain water. This will help to carry cuttings to the surface and will increase the pressure on the bottom of the sample during withdrawal from the borehole. Usually, the governing factor in preparing the drill fluid is the ability of the pumping equipment to circulate the fluid through the drill rods. It is advantageous to use a drill fluid that has a slippery feel.
2. When drilling through a dam, the potential for hydraulic fracturing at the bottom of the borehole should be evaluated. If hydraulic fracturing is possible, special drilling procedures should be used. These procedures may involve maintaining the fluid level in the borehole well below the ground surface and using augers to advance the boring. Tube samples can be obtained through large hollow-stem augers, or small-diameter solid augers may be used to clean out the hole inside casing.

- Several types of drilling fluids are available. Some of these include Revert, Quick Gel, and Kim-Mud. Revert is an organic material that decomposes a few days after mixing with water. It is commonly used if piezometers or a groundwater observation well are to be installed in the borehole. All three of these muds have worked well for removing sand-sized particles from boreholes.

7C.1.4 Mud Tub

It is important to have a mud tub with baffles that create settling basins for the cuttings. A mud tub with three or more settling basins is preferred. Cuttings should be shoveled out of the mud tub at frequent intervals to keep the drill fluid clean.

7C.1.5 Hole Advancement

- Drill bits must have deflectors that prevent drill fluid from jetting downward and disturbing the material below the drill bit. Tricone roller bits are available with a deflector attached to one of the cones that prevents drill fluid from jetting directly downward. It may be necessary to weld a bead on fishtail or chopping bits to deflect the drill fluid. Some bits have side or upward discharge of the drill fluid. The bit should be checked by flushing water through it above the ground surface.
- Drill bits should be slightly smaller than the I.D. of the casing. If 4-inch casing is used, the drill rods should be N or NW size to reduce the annular space between the casing and drill rods. This will increase the upward velocity of cuttings and will help to reduce wash at the bottom of the borehole.
- Advancement of the bit should be done at a slow rate of about 1 foot per minute maximum. Drill fluid pressure during drilling should be kept low to minimize disturbance to the material. After the required depth is reached, the bit should slowly be lifted a distance of about 3 feet above the bottom of the borehole. Then the drill fluid pressure can be raised to wash cuttings out of the hole.
- The drill bit and rods should never be allowed to rest on the bottom of the borehole. They should always be suspended from the drill rig. This is important so that potentially loose material is not densified or disturbed by the weight of the drill rods.

7C.2 PREPARATION OF SAMPLER

7C.2.1 Definition of Sampler Parts

TABLE 7C.1 STATIONARY PISTON SAMPLER WITH STEEL TUBE

Size	Sample Tube Length	Rod Conn.	Part No.	Weight	
				(lb)	(kg)
2" O.D. x 1 $\frac{7}{8}$ " I.D. ⁽¹⁾ (50.8 x 47.6 mm)	30" 762.0 mm	AW	22056-16	25.0	11.3
2 $\frac{1}{2}$ " O.D. x 2 $\frac{3}{8}$ " I.D. (63.5 x 60.3 mm)	30" 762.0 mm	AW	22053-16	28.0	12.6
3" O.D. x 2 $\frac{7}{8}$ " I.D. ⁽¹⁾ (76.2 x 73.0 mm)	30" 762.0 mm	NW	22041-43	30.0	13.6
3 $\frac{1}{2}$ " O.D. x 3 $\frac{3}{8}$ " I.D. (88.9 x 85.7 mm)	30" 762.0 mm	NW	22057-34	32.0	14.5
4 $\frac{1}{2}$ " O.D. x 40 $\frac{3}{8}$ " I.D. (113.7 x 110.5 mm)	30" 762.0 mm	NW	22065-34	36.0	16.3

Note: 1. Meets ASTM, AASHTO, DCDMA Standards for tubes.

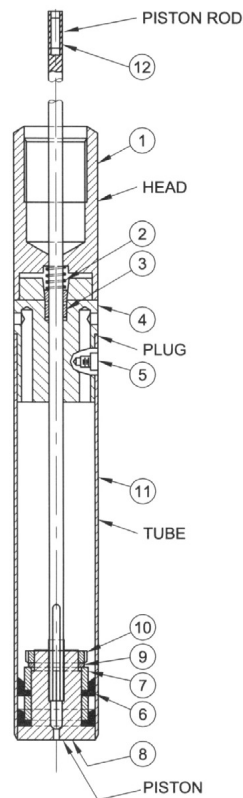

7C.2.2 General Operation of Sampler

With the sampler at the bottom of the borehole and the actuating rods fixed relative to the ground surface, the drill rods are pushed down. All of the parts, except the actuating rods and piston, move down. The locking cone allows one-way (upward) movement of the actuating rods and piston relative to the sampling tube. After the push, the piston cannot move down because the locking cone jams the actuating rods in place.

7C.2.3 Sampler Tube Preparation

7C.2.3.1 Cutting Edge

1. Before the drilling program begins, the cutting edge of each sampling tube should be machined to achieve the desired clearance ratio (CR) defined as:

$$CR = \frac{D_{IT} - D_{CE}}{D_{CE}}$$

where:

D_{IT} = inside diameter of tube (should be 2 7/8 inch)

D_{CE} = inside diameter of cutting edge

Usually, there is less chance of sand sliding out the bottom of the tube if the clearance ratio is relatively high. However, more disturbance of the sand occurs when the clearance ratio is relatively high because the sand expands outward to meet the sides of the tube.

Typically, sampling tubes obtained from Acker Drilling Company have clearance ratios of about 1.3 to 1.5 percent. For sand sampling, this clearance ratio is too high. Tubes should be machined to have clearance ratios between about 0.5 and 1.0 percent.

TABLE 7C.2 OPTIONS AND SPARE PARTS – STATIONARY PISTON SAMPLER⁽¹⁾

No.	Diameter and Head Thread Connection	2" O.D.		2½" O.D.		3" O.D.		3½" O.D.		4½" O.D.	
		AW	Wt. (lb)	AW	Wt. (lb)	NW	Wt. (lb)	NW	Wt. (lb)	NW	Wt. (lb)
		Part No.	(kg)	Part No.	(kg)	Part No.	(kg)	Part No.	(kg)	Part No.	(kg)
1	Head	120140-9	2.0 0.9	1201140-7	6.0 2.7	120140-10	6.0 2.7	120140-12	8.0 3.6	120140-16	11.0 4.9
2	Clamp Spring	120136	(1)	120136	(1)	120136	(1)	120136	(1)	120136	(1)
3	Cone Clamp Assembly	220042-1	(1)	22042-1	(1)	22042-1	(1)	22042-1	(1)	22042-1	(1)
4	Plug	120221	3.0 1.3	120189	5.0 2.2	120142	7.0 3.1	120226	10.0 4.5	120243	12.0 5.4
5	Socket Head Cap Screw (4 required)	120660	(1)	120652	(1)	120652	(1)	120652	(1)	120652	(1)
6	Packing Cup (2 required)	150045	(1)	150045-14	(1)	150045-11	(1)	150045-12	(1)	150045-18	(1)
7	Piston Spacer (2 required)	120222	(1)	120190	(1)	120138	1.0 0.45	120145	1.0 0.45	120297	1.0 0.45
8	Piston	120223	(1)	120295	1.0 0.45	120143	1.0 0.45	120225	1.0 0.45	120242	2.0 0.90
9	Lock washer	90399-04	(1)	90399-065	(1)	90399-08	(1)	90399-10	(1)	90399-15	(1)
10	Locknut	90400-04	(1)	90400-064	(1)	90400-08	(1)	90400-10	(1)	90400-15	(1)
11	Steel Tube – 30"	120021-4	3.0 1.3	120086-4	4.0 1.8	120037-4	5.0 2.2	120093-11	7.0 3.1	120095-4	7.0 3.1
11	Brass Tube – 30"	120245-4	3.5 1.5	120246-4	4.00 1.8	120038-4	6.0 2.7	120092-10	6.0 2.7	120094-4	7.0 3.1
11	Stainless Steel Tube – 30"	120245-4	3.5 1.5	120246-4	4.0 1.8	120230-1	5.0 2.2	120027-7	6.5 2.9	120244-4	7.0 3.1
12	Piston Rod-Master	120139-1	1.5 0.67	120139-1	1.5 0.67	120139-1	1.5 0.67	120139-1	1.5 0.67	120139-1	1.5 0.67
(3)	Act. Rod – 2 ft	120219-2	1.5 0.67	120219-2	1.5 0.67	120219-2	1.5 0.67	120219-2	1.5 0.67	120219-2	1.5 0.67
(3)	Act. Rod – 5 ft	120219-4	5.0 2.2	120219-4	5.0 2.2	120219-4	5.0 2.2	120219-4	5.0 2.2	120219-4	5.0 2.2
(3)	Act. Rod – 10 ft.	120219-5	7.0 3.1	120219-5	7.0 3.1	210219-5	7.0 3.1	210219-5	7.0 3.1	210219-5	7.0 3.1

Note: 1. For optional tubes, see Item 11.
1. Less than one pound or 0.45 kilogram.
2. Not shown.

(REPRODUCED FROM ACKER DRILL COMPANY INC. SOIL SAMPLING TOOLS CATALOG, 1978)

- Any nicks in the cutting edge should be repaired. A small machinist's file is useful for this purpose.
- The cutting edge I.D. should be measured at three to four locations so that an average cutting edge diameter can be determined. Also, the I.D. and O.D. of the tube should be checked. They are normally exactly 2⅞ and 3 inches. Field calipers should be used. Make sure that the calipers are aligned properly.

7C.2.3.2 Deburring and Cleaning

- The four holes at the top of the tube should be deburred using a file so that the plug can be inserted into the top of the tube.
- Wash all steel filings from the inside of the tube.

7C.2.4 Sampler Assembly

7C.2.4.1 Initial Cleaning of Parts

1. Locking Cone – should be free of all sand. Ball bearings should rotate freely. Spray with WD-40 (or similar light lubricant) to lubricate bearings.
2. Spring – a new spring should have the ends turned inward so that the ends do not become jammed between the locking cone and the plug. Clean spring of all sand.
3. Piston Rod – make sure that the beveled edge occurs on the threads of the piston rod only. The bevel should not extend below the threads. The piston rod must be deburred (filed smooth) above the threads so that the locking cone slides freely along the shaft. This should be done between each sampling attempt. The female threaded end of the piston rod should be thoroughly cleaned and lubricated with grease.
4. Plug – squirt water through the ports to clean out the sand and mud. Clean the female threads in the four side holes. Make sure the beveled hole at the top is free of sand and that the male threads are free of sand.
5. Head – clean thoroughly. Make sure there is no sand in the female threads.
6. Piston – make sure that sand is removed from the area behind the leathers. Clean the female threads with water. Make sure that the piston rod screws into the piston very easily (do not grease these threads). Leathers, which are referred to as packing cups (Part 6 in [Table 7c.2](#)), should be kept in water so that they remain pliable. Leathers should not have major cracks. The leathers should be coated with a thin film of high vacuum grease.

Initially, the piston and piston rod should be checked to make sure they are able to hold a vacuum beneath the piston. Put the piston near the bottom of a sampling tube with the piston rod screwed in position and place in a bucket of water. Pull up on the piston rod to check if water can be raised into the sampling tube.

7C.2.4.2 Assembly

1. Screw the piston rod tightly to the piston.
2. Place the tube horizontally on a table.
3. Push the piston from the top to the bottom of the tube. Make sure the piston bottom is flush with the cutting edge.
4. Install the plug and four screws. The screws should be finger tight.
5. Slide the cone into position. Use a screwdriver to push it in as far as possible.
6. Push hard on the piston rod to make sure the cone is seated. Check that piston has not moved out of the tube more than one-sixteenth inch.
7. Measure the stick-up of the piston rod above the plug top. This measurement will be used to determine the actual movement of the piston during sampling.
8. Install a rubber or plastic seal around the actuating rod and push it down over the locking cone. This seal can be made from a plastic end cap typically used to seal the ends of the tubes or from an old rubber glove. This seal minimizes the entry of sand into the cone. Failure of the locking cone has been attributed to sand getting below the cone preventing movement of the cone required for locking the piston rod.
9. Install the spring over the cone.
10. Install the head. Make sure that the spring seats properly into the recess in the head. Put thick strings between the head and plug and grease the threads. Tighten as tight as possible by hand. Later, this connection will be broken while soil is in tube. The string and grease make it easier to break the connection without shaking the tube.

11. If an NW-AW sub is used, record the stick-up of the actuating rod above the sub. This will be used to determine if the actuating rods and piston moved up in the tube while the tube was being lowered down the borehole.
12. Put the plastic cap over the cutting edge of the tube to protect it.
13. Do not rest the sampler on the piston because the piston can move up into tube.

7C.3 SAMPLING PROCEDURE

7C.3.1 Preparation of Actuating Rods inside Drill Rods

All actuating rod threads should be cleaned and greased.

7C.3.1.1 Separate Drill Stem and Sampling Stem

It is often more efficient to use two sets of drill rods (with only one set down the hole at any one time). One set would have actuating rods inside and be used for sampling only. Using two sets of drill rods is especially beneficial when the depth of the hole extends beyond 30 feet.

7C.3.1.2 One Drill Stem

1. After drilling is completed, actuating rods can be placed down the drill rods and rest on the roller bit so that the entire string can be lifted out as a unit.
2. Protection for the male actuating rod thread at the bottom should be provided.
3. It is important to have a bleeder pipe (2-foot length of rod with holes through the side) just above the drill bit to allow the escape of drilling fluid from the rods.
4. It is desirable to have a short length of actuating rod at the bottom of the actuating rod string so that the actuating rods stick up above each corresponding drill rod by about 2 to 18 inches.

7C.3.2 Attaching Sampler to Drill Rods

1. Have drill rods ready with the actuating rods inside.
2. Make sure that the bleeder pipe is at the bottom of the drill stem.
3. Screw the sub part way onto the bottom of the drill rods.
4. Put a vise grip at the bottom of the actuating rods and a vise grip on the piston rod.
5. Raise the drill rods high enough to attach the sampler.
6. The driller should hold drill rods so they don't move. They usually extend far above the drill rig and must be held securely.
7. The helper and inspector attach the tube – do not allow the bottom of tube to rest on any surface.
 - a. Connect the actuating rod to the piston rod with vise grips, making sure the piston rod is not turned.
 - b. Unscrew the sub from the drill rods and screw the sub onto the sampler head. Make sure a string is in the joint.
 - c. Lift the sampler and the actuating rods that have been attached to the piston rod, and screw the sampler to the drill rods (this is the hardest part).
8. Remove the plastic cap and check that the piston has not moved. Note how much the piston is protruding below the cutting edge. This procedure is easier if NW drill rods are used because then an NW-AW sub is not required. The procedure for attaching the sampler to the drill stem will vary from one project to another and with the available drilling equipment.

7C.3.3 Lowering Sampler down Hole

1. Carefully place the tube into the hole without nicking the cutting edge. If the cutting edge is nicked, start over.
2. Slowly lower the sampler down the hole. When connecting actuating rods, never turn the lower actuating rod as this will release the vacuum port in the piston. Measurements of the stick-up of the actuating rods above the drill rods should be made whenever drill rods are joined as a check on the location of the piston in the sampling tube.
3. Stop lowering sampler about 1 to 2 feet above the bottom of the hole.
4. Measure the stick-up on the actuating rods. Is it correct? If the sampler hit a lot of wash, the actuating rods will be higher. String between joints of drill rods may make the drill stem slightly longer. Measure the drill rods if a problem is suspected.
5. Fix the actuating rods to the drill rods with a special coupling with a set screw. See sketch below.

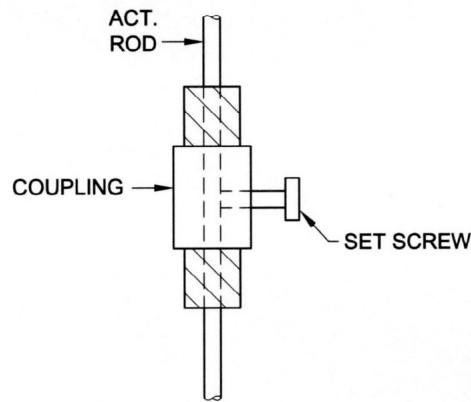

6. Put a keel line just above the coupling.
7. Very slowly, with the hydraulic cable (or cathead and rope) and pull ring, lower the sampler until it rests on the bottom. First put a keel mark on the drill rods so that the keel mark will line up with the top of the casing when sampler is supposed to reach bottom. This will warn when the sampler is getting close.
8. Check to make sure that the actuating rods did not slip in the coupling.

7C.3.4 Preparation for Push

Make sure that there is a stable surface for making measurements of the drill rod relative to the casing. Use the top of the casing itself, or the pull-plate resting on the casing.

1. As soon as the sampler is resting on bottom of borehole, measure the actual depth of the bottom of the piston sampler.
2. Put a mark on the drill rod 24 inches above reference. Do this immediately, in case the sampler creeps down before push.
3. Set up frame to fix actuating rods. The frame shown on the following page is suggested:

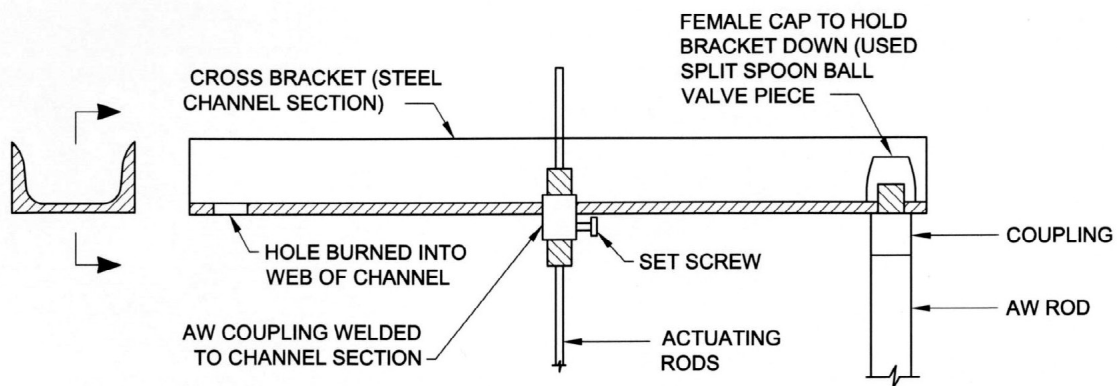
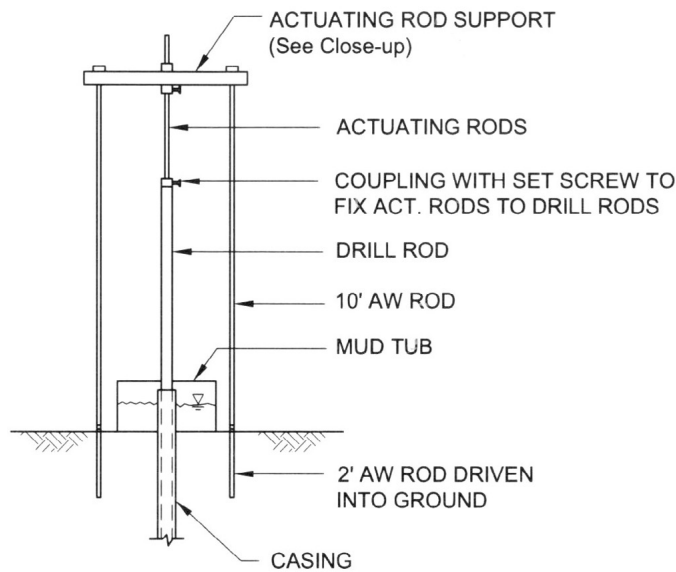

The 2-ft AW rods driven into the ground should be as close as possible to the mud tub to minimize the span length of the upper cross bracket.

Fixing the actuating rods to the rig has proven unreliable because the rig can move (lift up) during sampling. Using cables to hold the actuating rods is very bad because they allow movement due to slack in cables.

4. Tighten set screw in top cross-bracket (very tight). Place a vise grip very tightly on actuating rod just above top coupling as a safety measure to keep actuating rods from moving down.
5. Measure the distance from the bottom of the top coupling to the reference plate (a_1) to the nearest one-sixteenth inch.
6. Measure distance from reference plate to an arbitrary point on the actuating rod just above drill rods (b_1) to nearest one-sixteenth inch. This will give the actual movement of the actuating rod, including slippage if it occurs.

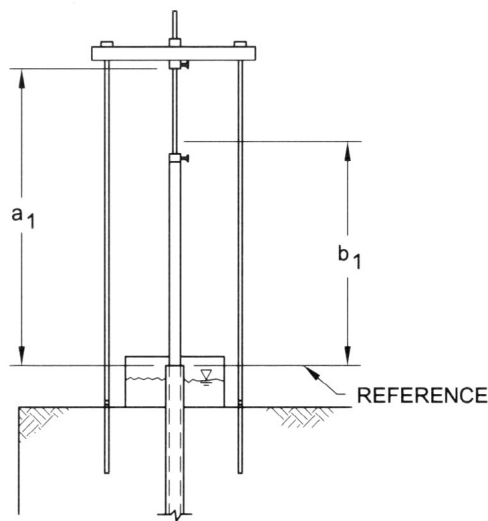

7. Check that mark on drill rods is still 24 inches (c_1) above reference plate. This will be used to determine actual push length.
8. Measure distance from a reference plate on the ground to a mark on the AW rods (d_1). This will be used to determine whether the support footings move during sampling.

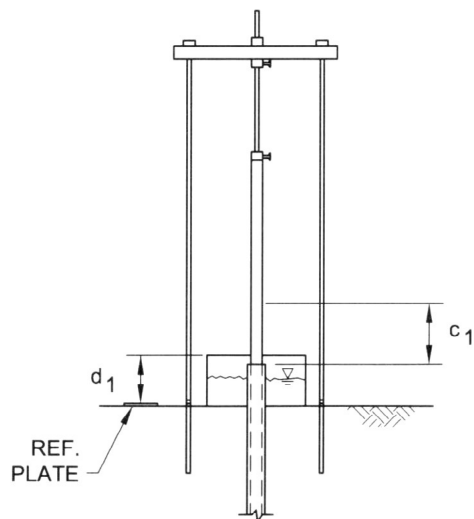

9. Determine the required rate of push and have driller set controls to achieved desired rate. The driller can experiment with rig controls.

On many drilling rigs, the hydraulic pressure gauge indicating downward pressure on the drill head will be very useful. If gravel is present in sandy soils, the tube may crumple if the cutting edge hits a large piece of gravel. By experimentation, a limit hydraulic pressure can be set which, if exceeded, would mean that the tube was hitting gravel, and, if not exceeded, would mean that the tub penetrated relatively easily for the entire push length.

On some drilling rigs, the hydraulic pressure gauge will not be informative because it is not sensitive to resistance against the drill head. Before sampling, determine how the hydraulic pressure gauge works.

- a. Determine hydraulic pressure for the drill head moving down with no resistance (reference pressure).
 - b. Determine hydraulic pressure change for the case of the rig weight acting on the drill stem.
 - c. Decide if monitoring the gauge during sampling will be useful
10. It is important to have a stable connection between the drill head and the drill rods during the push.

On most drilling rigs, the drill heads are rounded and do not provide a good pushing surface. A special bracket can be fabricated to allow the head to push down on the drill rods, as shown in the sketch below:

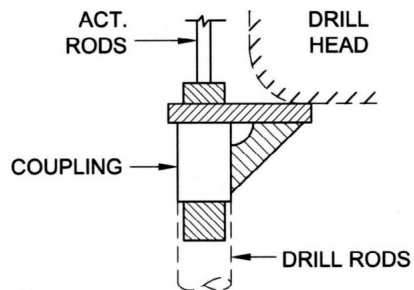

Alternatively, a right-angle block that allows direct pushing on the drill rods can be attached to the drill head.

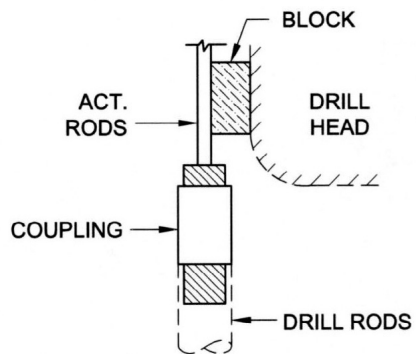

7C.3.5 Advancing Tube

7C.3.5.1 From Weight of Rods

With the actuating rods fixed to top bracket, release the actuating rods from the drill rods. Then re-measure a , b , c , and d and record on data sheet. Compute the following:

1. Penetration due to weight of rods = $c_1 - c_2$
2. Movement of actuating rods = $b_1 - b_2$
3. Movement of cross bar = $a_1 - a_2$
4. Movement of support rods = $d_1 - d_2$

7C.3.5.2 From Drill Head Push

1. The tube should be pushed in a smooth continuous motion, if possible.
2. The driller should be given a mark on the drill stem to watch.
3. It is prudent to push only 22 to 23 inches because there is not much space (less than 1 inch) between the top of the piston and the bottom of the plug when a 24-inch push is completed. If fines have settled out on top of the piston and the fines encounter the plug, the soil in the tube will be compressed and the actuating rods will probably slip in the cross frame.
4. The inspector or helper should time the push. If necessary, the hydraulic pressure gauge should be observed by the inspector. The driller should watch the mark on the rods.
5. After pushing the tube, back off the drill head of the rig.

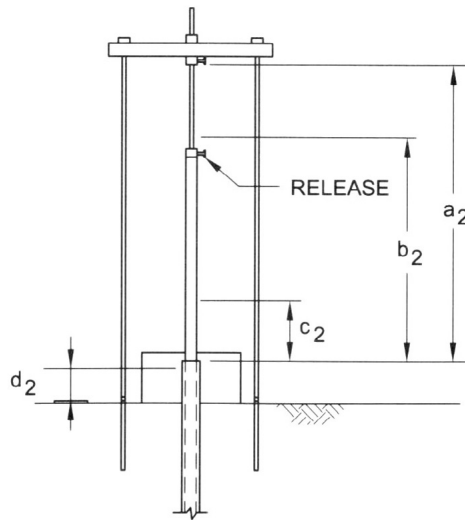

7C.3.6 Post-Push Measurements

1. Total Penetration – The total penetration ($c_1 - c_3$) includes penetration from the weight of the drill rods.
2. Movement of Actuating Rods – Measure and record b_3 . Record the net movement of the actuating rods
3. Movement of Actuating Rod Support – The actuating rods are now fixed to the bracket and are in tension and may have pulled the support bracket down. Measure and record a_3 . Record the net movement of actuating rod supports.
4. Movement of Support Footings – Measure d_3 and record. Also record the net movement of the support footings.
5. Release Actuating Rods from Bracket – Have the driller release the actuating rods from the top of the bracket. Measure and record a_4 (top bracket may have sprung upward when it was released from the act. rods). Measure and record d_4 . Record net movements of a, b, and d.

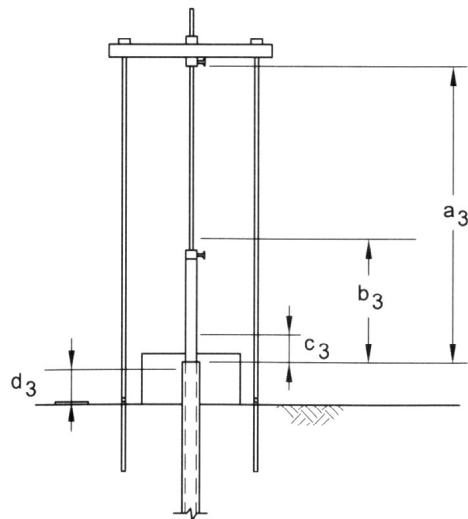

7C.3.7 Lifting Sampler up Borehole

1. Disassemble actuating rod support frame.
2. Put a full head of drill fluid in the borehole.
3. Rotate tube about twice – initially, the drill rod joints will come together. The actuating rods should not be tightened to drill rods. As soon as the actuating rods begin turning along with the drill rods, stop rotation. Measure b_5 and c_5 (initial distances from a reference to points on the actuator rods and the drill rods). Rotate the rods two full revolutions (or less, if specified), then re-measure b_6 and c_6 . Compute $c_5 - c_6$ (penetration during shear). Rotation should be performed more than 10 minutes after the push.
4. Lifting the tube the first 2 feet is one of the most critical parts of the operation. As the sampler is lifted, a vacuum will develop at the bottom of the tube tending to suck the soil out of the tube. The tube should be lifted as slowly as possible without jarring or vibrating the drill stem. At the same time that the tube is being lifted, the drill stem should be rotated carefully in a manner such that the rods do not whip and the wrench does not slip. Lifting the first 2 feet has been accomplished as follows:
 - a. A swivel can be attached to the drill stem and hydraulic cables used to lift the tube. The hydraulic cables should be operated slowly enough to lift the tube in 20 to 30 seconds.
 - b. On some drilling rigs, the cable hydraulics are not sensitive enough to lift the tube smoothly. In such cases, a rope can be wrapped around the drill head and tied around the drill rods. The drill head can then be raised as slowly as possible, using the rope to facilitate rotation of the drill stem. A full head of drilling fluid should be maintained in the borehole during this operation. Note if the drill fluid drops temporarily when the tube has been lifted approximately 24 inches. If the fluid drops, this may indicate that the soil is in the tube and the fluid has dropped into the hole formed.
5. If two drill rod stems are being used, slowly lift the drill rods and actuating rods out of hole at less than 1 foot per second. Maintain head. If the rod joints must be broken, make sure that rope has been placed in the joints. When breaking actuating rods, use vise grips to make sure that lowermost actuating rod does not move.
6. If one drill rod stem is being used, before lifting rods, remove as many actuating rods from hole as possible. If this procedure is used, the actuating rod joint at the top of the

piston rod should have been made the loosest and be well greased and not tightened all the way. Other actuating rod joints should have been tightened very tight with vise grips. Then, when unscrewing the actuating rods at the surface, all the actuating rods above the piston rod can be removed. This speeds up the operation considerably.

7C.4 SURFACE HANDLING OF SOIL-FILLED SAMPLER

7C.4.1 Removal of Sampler from Borehole

1. Maintain a head of drilling fluid at all times. When the sampler nears the surface, make sure that the water flowing into the casing is not too turbulent, which could cause erosion of the soil at the bottom of the tube. A stocking over the end of the hose can be used to reduce turbulence.
2. When the bleeder pipe is observed, reduce the rate of movement to as slow as possible, but do not decelerate too rapidly.
3. As soon as the bottom of the sampler surfaces, slide a plate under the sampler to prevent any soil from falling out. Do not put fingers under the cutting edge of the tube. Wait until the drill stem is stable.
4. Start sliding the plate away. Be very careful that fingers are not placed directly under the cutting edge.
 - a. If soil starts falling out, put the plate back. Have a piece of foam rubber approximately 3 inches in diameter and approximately 2 inches thick ready for placing at the bottom of the tube. Make a quick switch of plate and foam rubber and place a plastic cap at the bottom of the tube. Tape the plastic cap in place. The foam rubber will conform to the soil surface and provide resistance to slippage of the soil.
 - b. If soil stays in, which it probably will, make a quick observation of the shape of the bottom soil surface and record later. If soil is flush with the bottom, install plastic cap and tape. If soil is missing up to 2 inches from the cutting edge, put a cylindrical piece of foam in the bottom and cap. If soil is far up into tube, install a vented packer with an extension used for tightening. Filter paper should be placed on the packer.
5. Disconnecting the Sampler. Make sure that the sampler does not rest on a surface with the weight of the drill rods on it, because it could bend or kink.
 - a. If the actuating rods are left inside the drill rods during withdrawal of the sampler, the following procedure is suggested: (a) break the joint at the bottom of the 2-foot bleeder pipe, (b) lift the drill stem with rig hydraulics, and (c) unscrew the actuating rods.

Do not let the sampler drop. A piece of foam can be placed under the sampler so that when it is unscrewed it will drop approximately $\frac{1}{4}$ to $\frac{1}{2}$ inch onto foam (there may be considerable weight above from the actuating rods and soil in the tube).
 - b. If the actuating rods are removed prior to bringing the sampler to ground surface, unscrew the sampler at a convenient joint.

7C.4.2 Installation of Bottom Packer

The bottom packer is installed while the piston is still in place so that a vacuum holds the soil in the tube. Do not turn the tube upside down.

The sampler must be suspended above ground so that the bottom can be worked on. This can be done by mounting a chain clamp to a stationary object free from vibrations (i.e., a work bench or tree, but not the drill rig or other equipment). The head of the sampler (not the tube should be strapped in, allowing the bottom to be worked on.

Alternatively, the sampler can be suspended by a rope from the derrick of the drill rig. The 2-foot bleeder pipe should be kept on the sampler so that a swivel can be attached. The rope should be tied off at the rig. This method is less efficient than the chain clamp method because the drillers cannot advance the hole while the sample is being worked on by the inspector.

1. Remove temporary bottom cap. Note condition of cutting edge and sketch if it is distorted.
2. Measure distance from cutting edge to soil surface. Sketch profile. Record.

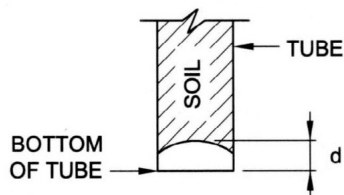

3. Remove soil with putty knife. Save cuttings in baggie and jar.
4. Prepare final bottom surface with trimming tool. Make flat. Final surface should be 1 $\frac{3}{8}$ inch or more from cutting edge for packer to fit.
5. Clean inside wall of tube so that packer will not slip.
6. Measure to soil at three locations.
7. Install packer, vented, with filter paper. Pull down hard on packer to confirm that it is tight.
8. Measure at three locations to bottom of packer.
9. Install bottom plastic cap with holes for drainage.

7C.4.3 Removal of Piston

Carefully place the sampler on foam and support it so it is stable and wrapped with foam or mounted in a chain clamp to minimize vibrations.

Carefully unscrew the joint between the head and the plug. Remove the head.

1. Remove spring.
2. Clean top of plug and around cone. A squeeze bottle may be used.
3. Measure from top of plug to top of actuating rod. Record distance from tube bottom to piston. Is this the same as the penetration distance?
4. Remove cone: using vise grips, rotate piston rod clockwise while putting sideways force on piston rod. The cone will climb the piston rod. After removing the cone, screw the piston rod back down to plug piston.
5. Remove plug.
6. Measure distance from top of tube to top of wash resting on piston. Did the wash push up against plug?

7. Remove fluid and wash resting on top of piston.
 - a. This can be accomplished by sucking into a long tube and/or using a squeeze bottle.
 - b. Be sure to clean the piston around the piston rod so that air (not fluid) can travel around piston rod to release the vacuum.
8. Unscrew piston rod to release vacuum. Screw piston rod back in part way to pull out piston.
9. Pull out piston slowly. Use piston rod to loosen leathers by swaying piston rod back and forth. Can use vise grips and wood block to lift if it cannot be done by hand. If vacuum is not releasing, soil may be stuck to piston. Stick a wire through port to pierce soil. It is important to prevent soil and fluid above piston from getting below piston.
10. When the piston is removed, note if soil is stuck to the piston and record thickness. This is part of gross recovery.

7C.4.4 Cleanout of Top

1. Measure distance from top of tube to fluid above soil and record.
2. Measure distance from top of tube to soil at three locations and record.
3. Record gross recovery and net recovery

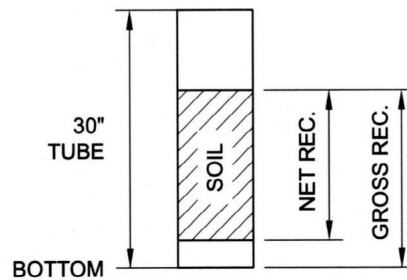

4. Was the fluid level at the same locations as the bottom of the piston? Remove a sample of the drill fluid above the soil. Is it water or drilling fluid? Is it from the pores of the soil?
5. Remove all fluid resting on top of soil.
6. Use trimming tool to remove wash from top.
7. Note: If suction developed below the piston while the piston was being removed, some soil may have lifted. Slight pressure from a ruler will cause this to drop down.
8. Use foam rubber to remove slop from top of soil. Make sure top of soil is nearly level.
9. Measure to top of soil in three places. Record.

7C.4.5 Installation of Top Packer

1. Prepare the bottom half of a vented packer with a filter paper and a wire for future retrieval.
2. Place packer on top of soil. This provides a good level surface for measuring.

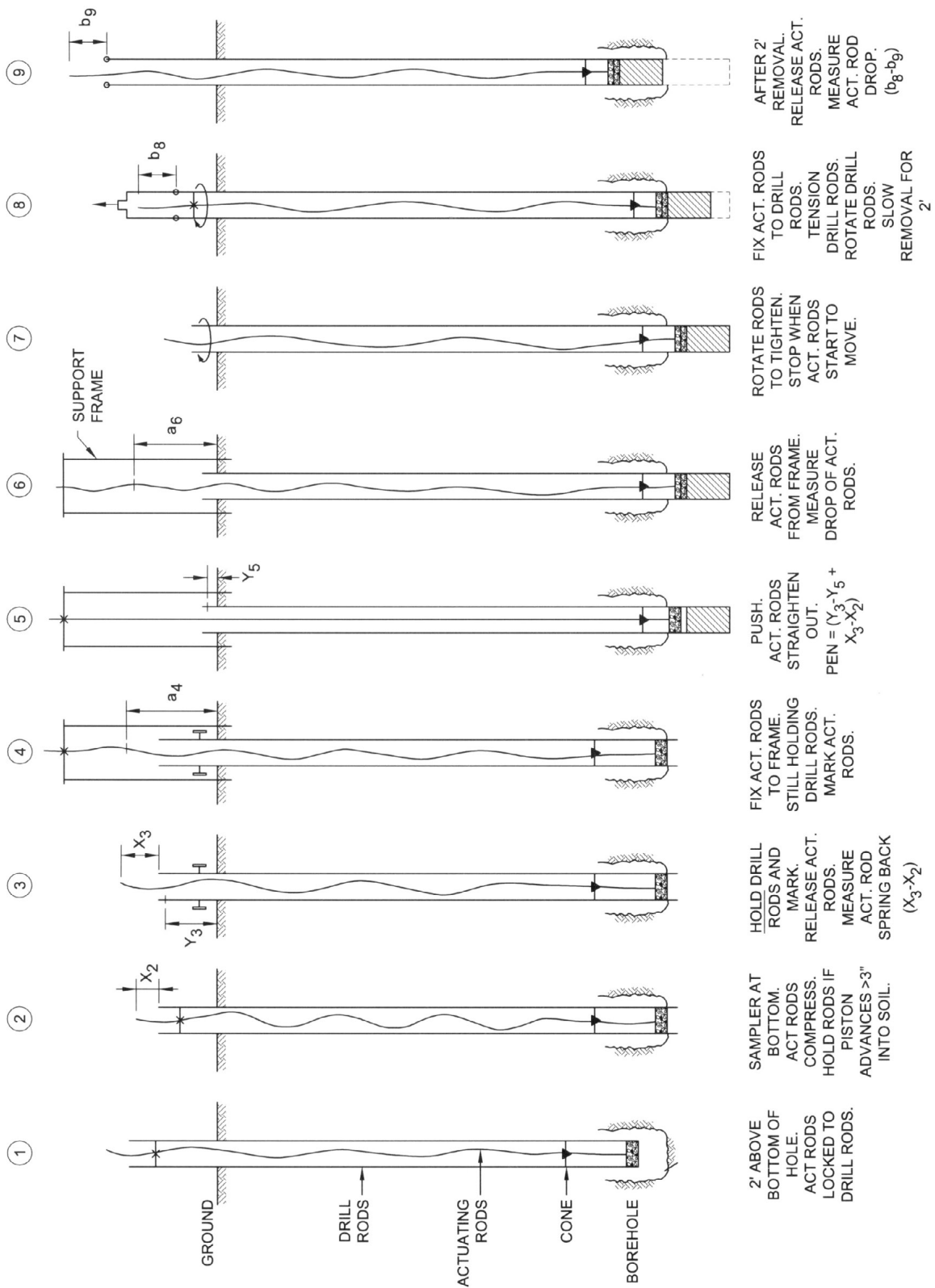

3. Measure accurately at three locations. These data will later be used for monitoring height changes during handling and shipment. Record.
4. Put a moistened paper towel in top.
5. Put a vented plastic cap on top and tape in place.

7C.4.6 Preparation for Shipment

1. Label with the following:
 - Top
 - Project Number
 - Project Name
 - Boring Number, Sample Number
 - Depths
 - Penetration, Gross Recovery, Net Recovery
2. If needed, apply vacuum below bottom packer to draw water out of sample. This will increase the stiffness of sand without significantly changing the void ratio.

Appendix 7D

COMBINING NEWMARK-TYPE DISPLACEMENTS COMPUTED USING 1D SITE-RESPONSE ANALYSES

The computer program SHAKE calculates time histories of horizontal shear stress acting at the boundaries of soil layers. To calculate a time history of acceleration for a wedge, and then a displacement, the following procedure can be used (Figure 7D.1):

1. Perform SHAKE analyses for two representative profiles through the potential wedge to obtain horizontal shear stress time histories $\tau_h(t)$ at two points A and B on the sliding surface.
2. Calculate the time history of the average acceleration $k(t)$ of the soil above the two points:

$$k_A(t) = \tau_{hA}(t) / \sigma_{vA} \quad k_B(t) = \tau_{hB}(t) / \sigma_{vB}$$

where:

$$\begin{aligned} \tau_{hA}(t) &= \text{earthquake shear stress at point A} \\ \tau_{hB}(t) &= \text{earthquake shear stress at point B} \\ \sigma_{vA} &= \text{total vertical stress at point A} \\ \sigma_{vB} &= \text{total vertical stress at point B} \end{aligned}$$

3. Integrate the $k_A(t)$ and $k_B(t)$ time histories for various values of k_y to develop curves of k_y/k_{max} versus displacement (Figure 7D.1).
4. Compute $k_{OVERALLmax}$ for the entire wedge:

$$k_{OVERALLmax} = \frac{k_{Amax} W_A + k_{Bmax} W_B}{W_A + W_B}$$

where:

$$\begin{aligned} k_{Amax} &= \text{maximum value of } k_A(t) \\ k_{Bmax} &= \text{maximum value of } k_B(t) \\ W_A, W_B &= \text{weights of portions A and B of failure wedge} \end{aligned}$$

5. Using the value of k_y computed from the pseudostatic stability analyses, calculate k_y/k_{max} and enter the curves developed in Step 3 to obtain a displacement.

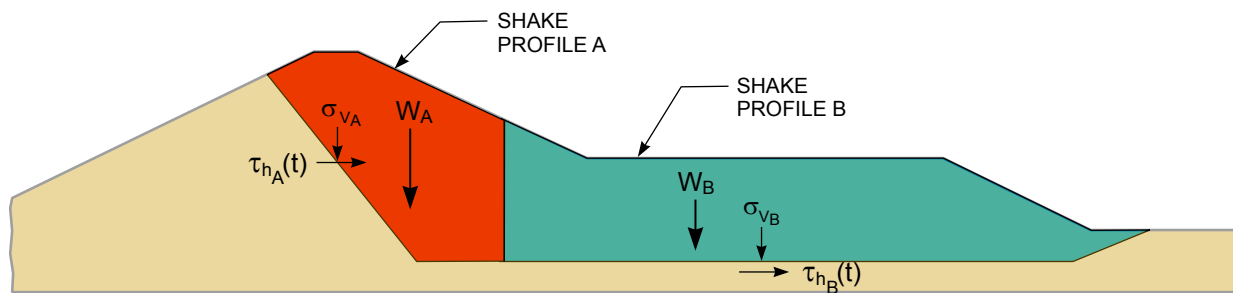

$$k_A(t) = \frac{\tau_{hA}(t)}{\sigma_{vA}} \quad k_{Amax} = \text{maximum of } k_A(t)$$

$$k_B(t) = \frac{\tau_{hB}(t)}{\sigma_{vB}} \quad k_{Bmax} = \text{maximum of } k_B(t)$$

$$k_{OVERALLmax} = \frac{k_{Amax} W_A + k_{Bmax} W_B}{W_A + W_B}$$

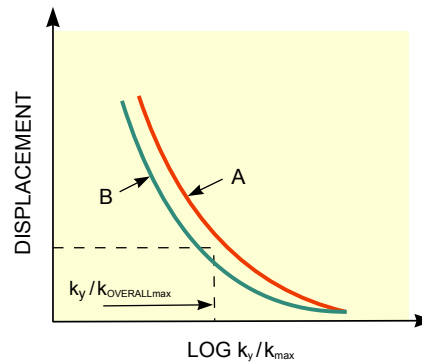

- where:
- $\tau_h(t)$ = time history of horizontal shear stress
 - σ_v = total vertical stress
 - $k(t)$ = time history of average acceleration of mass above point of interest
 - W = weight

FIGURE 7D.1 DEFORMATION ANALYSIS USING SHAKE

Chapter 8

SITE MINING AND FOUNDATION ISSUES

The construction of embankments and impoundments for coal refuse disposal and process water supply is an integral part of most coal mining operations. However, in many coal mining areas, it is difficult to locate a site for construction that has not been or will not be undermined to some extent, especially near the coal preparation plants that the impoundments serve. When mining is planned or is occurring in the vicinity of an impoundment, measures must be taken to evaluate the potential impact of mining-induced movement on both the safety of the embankment and the integrity of the impoundment. The potential for water or slurry from the impoundment to affect the safety of underground mine workings must also be considered. Even for non-impounding embankments, there may be performance concerns related to drainage structures that could be affected by surface movement induced by underground mining. Additionally, environmental considerations with respect to the effects of mining on the hydrogeologic regime may be important.

It can be difficult to identify and evaluate the potential subsidence mechanisms that may induce ground movement and affect the integrity of a refuse embankment or impoundment area because of uncertainties or inaccuracies related to the location of mining and the characterization of overburden and protective features such as barriers and mine seals. Accordingly, designers need to take steps to accurately assess these features and to provide appropriate protective measures.

An assessment of the potential for mining to affect the safety of an impoundment should be addressed in plans submitted to MSHA for approval as per 30 CFR § 77.216-2. Applicable MSHA permit requirements related to the potential for an impoundment to affect the safety of underground mine workings can be found in 30 CFR § 75.1716, which identifies requirements for obtaining permits when mining is planned under a body of water of sufficient size to present a hazard to miners. Because mining in the vicinity of an impoundment can present a hazard due to fracturing of the overburden beyond the horizontal limits of mining, MSHA may require a permit even in situations where the mine workings do not extend directly under the impoundment.

This chapter focuses on coal refuse impoundment design issues caused by the presence of underground mine workings, mine spoil materials, and mine highwalls. Based on past experience, these design issues include:

- Mine subsidence where the load imposed by overburden and/or an impoundment causes ground movement from the caving of overburden strata and/or crushing or

bearing capacity failure of pillars. This response can impact the hydrogeology (i.e., seepage rates and paths), cause differential movements in the dam or impoundment reservoir area, result in loss of impoundment freeboard, and disrupt internal drainage systems. Mine subsidence can also aggravate pre-existing conditions and create a weakened or worse state that increases susceptibility to other failure mechanisms.

- Mine breakthrough where the load imposed by the overburden and impoundment or deterioration due to weathering, degradation or seepage forces causes collapse of overburden strata and uncontrolled release of fluid fine coal refuse and water into mine workings and beyond. Breakthroughs have also occurred where an impoundment intersects a coal seam or overburden barrier left in place to protect active or abandoned mine workings and the hydraulic load imposed by the impoundment exceeds the resistance provided by the barrier.
- Mine blowouts where water impounded in an underground mine breaks through a sealed mine opening and/or a section of the coal outcrop barrier. A blowout can be a secondary consequence of impoundment breakthrough into an underground mine or a result of natural accumulation of water or of underground slurry disposal.
- Seepage, internal erosion and stability concerns when an embankment is to be constructed over an area where there may be mine openings related to highwall mining and auger holes.
- Seepage and internal erosion concerns where an embankment is to be constructed on top of spoil and the spoil was placed under uncontrolled conditions.
- Seepage and internal erosion concerns where an embankment abuts a steep rock slope or highwall.

For non-impounding embankments, mine subsidence can cause disturbance to internal drainage systems, surface water control structures, slopes and liner systems. Additionally, surface cracking can lead to increased infiltration of water. Thus, potential underground mining impacts can be important design considerations for non-impounding structures.

Descriptions related to the circumstances behind and lessons learned from 11 mine breakthrough and four mine blowout events are presented in Appendix D of an MSHA (2003) report to congress titled, *Guidance for Evaluating the Potential for Breakthroughs from Impoundments into Underground Mine Workings and Breakthrough Prevention Measures*. This chapter draws extensively from the 2003 MSHA report for guidance related to underground mine issues.

8.1 GENERAL CONSIDERATIONS

In addition to other geotechnical considerations associated with coal refuse disposal facilities, there are siting factors and structural analysis and design issues that need to be considered when a facility is sited above or adjacent to abandoned, active or planned future underground mine workings. These factors and issues include:

- Availability of information resources including mine maps, coal contour and outcrop maps and the interpretation and accuracy of such maps (i.e., certified as accurate or uncertified, includes the latest mining activity, etc.).
- Availability of on-site reconnaissance and surface exploration data related to the identification and mapping of geologic features, soil and rock overburden and natural outcrop barriers, and underground mine voids. These data may originate from surficial mapping, geophysical methods, long-hole directional drilling, and conventional drilling and sampling.

- Evaluation of the potential for mine subsidence and breakthrough and mine seal barrier failure considering possible failure mechanisms and methods of evaluation and analysis.
- Available methods and design measures for mitigating or controlling mine subsidence and breakthrough and mine seal barrier failure.
- Impoundment construction and operations monitoring guidelines.
- Surface mine spoil properties, if such material is present in foundation zones or used in constructing embankments.
- Surface mine bench/highwall issues.

8.2 AVAILABLE SOURCES OF SITE INFORMATION

MSHA (2003) developed guidelines for evaluation of sites with potential for breakthrough into underground mines, covering preliminary investigation, on-site reconnaissance, and direct/detailed investigation. [Table 8.1](#) presents sources for information related to mine maps, conditions, and records. Further discussion is presented in the following paragraphs.

A general discussion regarding the location, content and accuracy of mine maps with respect to the planning of site reconnaissance and exploration programs and the geotechnical analysis and design of coal refuse disposal facilities is presented in [Section 6.4.1.5](#) of this Manual. The discussion presented herein relates to the general usefulness of mine maps with respect to locating coal contours and outcrops and to mine map interpretation and accuracy based on information from MSHA (2003) and NRC (2002).

8.2.1 Mine Maps

Underground mine maps can be used to locate a mine with respect to the surface or other underground mines and to determine the dimensions of pillars and mine openings. Information provided on most underground mine maps includes:

- Pillared, worked out, and abandoned areas; pillar locations; extraction heights; sealed areas; future mining projections; adjacent mine workings within 1,000 feet; locations of surface or auger mining; mined areas of the coal bed; and the extent of pooled water at the time the map was prepared.
- Dates of mining, coal seam sections, coal seam elevations, and survey data and markers.
- Surface features, coal outcrop, and 100-foot overburden contour or other prescribed mining limit; mineral lease boundaries; surface property or mine boundary lines, and identification of coal ownership.
- Areas used for underground injection of coal refuse slurry, acid mine drainage sludge, or other sediments or wastewater.

Sources for mine maps include local mining and mineral rights holding companies, local engineering and surveying firms, as well as the OSM National Mine Map Repository and state regulatory authorities. Other sources could include museums, mining schools, and mineral resource organizations. Mine maps should be assessed to determine their reliability (e.g., determining if mine production continued after the date of the map). [Table 8.1](#) cites potential information sources or methods for corroborating mine maps, and [Table 8.2](#) lists federal and state agencies that may have data bases and can provide assistance in locating mine maps. Exploration and reconnaissance methods for evaluating underground workings when there is no mapping or when available mapping is suspect are presented in [Section 8.3](#).

TABLE 8.1 SOURCES OF INFORMATION FOR EVALUATION OF BREAKTHROUGH POTENTIAL

1. Search available mine maps for the area. The local mining companies should be contacted. Other potential sources of mine maps include OSM's National Mine Map Repository, museums, mining schools, and state agencies that deal with mine safety and reclamation.
2. Where there are multiple coal seams, the mine maps for each seam should be obtained.
3. Available aerial photographs of the area should be checked for indications of mine openings, auger openings, other types of surface disturbance, or the presence of mining facilities.
4. Topographic maps should be checked for indications of mine openings or mine facilities.
5. Geologic maps and cross-sections should be checked for the presence of coal seams in the area.
6. Available information on the condition of, and surface disturbance to, the outcrop barrier and overburden should be collected and reviewed. This would include geologic maps, aerial photographs, publications available from government agencies, and previous engineering reports, plans, or permits pertaining to the area.
7. Review boring logs from drill holes in the area, potentially for coal or gas exploration as well as geotechnical purposes.
8. Collect and review available information on the mining conditions and practices for workings under or near the site. Include information on: roof falls; roof support measures, especially supplemental support used near the outcrop or under shallow cover; pillar stability, particularly information on second mining of pillars; and floor conditions, especially information on punching or heaving.
9. Interview miners, especially older or retired miners who worked in the area, concerning the mining conditions, including roof, pillar, floor, and water conditions; the practices used when mining near the outcrop; and whether the available mine maps are consistent with their knowledge of the mining that took place.
10. Interview mine surveyors who may have worked in the area about their knowledge of mining in the surrounding area.
11. Search available information on auger mining. Often the depth of auger holes are not shown on the mine map, or only approximate depths are indicated.
12. Compare production records with the data on mine maps to help validate that additional mining did not occur after the mine map was produced.

(MSHA, 2003)

8.2.2 Coal Contour Maps and Outcrops

A coal outcrop is generally regarded as the location (horizontal or at a slope equivalent to the dip of the seam) where the bottom of the coal seam intersects the surface, and it is commonly represented as the coal outcrop line on contour maps. Because the actual coal seam is generally not visible at the surface, the outcrop line is usually shown as a contour corresponding to the bottom elevation of the coal seam in that area. Subcrop locations, which are interfaces with other geologic media, are sometimes shown as lines on mine maps where the coal crops out below glacial, alluvial or other sediment deposits or volcanic material.

At some sites, coal outcrops are visible because of surface mining activities, abandoned portals, outcrop sample areas, auger mining, highway cuts, house and building excavations, and house-coal openings. However, locating coal outcrops in steeply sloped areas may be impractical because of difficult access to the outcrop areas and the need for surface excavation. Field location of outcrops can also be complicated by the presence of unmined coal horizons; multiple coal seams in the same vicinity; and spoil, refuse, backfill, or other fill material placement.

The steepness of the ground surface, stress relief fracturing, weathering, hillside creep, landslides, and man-made disturbance can all affect the coal at a projected outcrop location. These effects, cou-

TABLE 8.2 SOURCES FOR MINE MAPS

OSM National Mine Map Repository	Indiana Geological Survey
Virginia Department of Mines, Minerals, and Energy	Ohio Division of Geological Survey
West Virginia Geological Survey	Ohio Division of Natural Resources
Kentucky Map Information Center	Maryland Coal Mine Mapping Project
Pennsylvania Department of Environmental Protection	Utah Geological Survey
Illinois Department of Natural Resources	

pled with the possibility that the projected coal outcrop location may be inaccurate because of local changes in coal structure, may complicate coal barrier analyses.

The surface topography maps submitted to MSHA, OSM, and state regulatory authorities delineating coal outcrop locations are usually scaled at 500 feet or less to the inch. The maps are typically based on aerial photography or USGS mapping. Coal outcrop locations are usually projected based on the structure of the coal and its inferred (and sometimes measured) intersection with the ground surface. It is recommended that the coal outcrop location be measured and the distance from the ground surface to intact coal determined at impoundment sites where breakthrough potential is a concern.

Most mid- and large-size coal companies currently employ precise surveying techniques and mine planning software to generate mine maps. This has been prompted by the need to accurately locate ventilation shafts, to prevent mine pool blowouts, and to have accurate locations should a mine rescue be necessary. These software codes utilize data from borehole geotechnical and geologic logs, horizontal drilling, surface geophysical exploration, outcrop exploration, land and in-mine surveys and topographic mapping to generate an outcrop line on maps. The results are generally more accurate than previous methods; some mining companies make these maps available.

One of the key steps in delineating coal outcrop locations on surface topographic maps is the coordination of survey control points. Common control points should be used for both the underground mine map and the surface topography map. The accuracy of each map generated from these common control points is then a function of the equipment or method used to create the elevations and contours. Where practical, and at critical locations, surface topographic surveys should be conducted along the coal outcrop as part of permit submittals. These surveys should fully document existing locations where the coal seam is already exposed due to natural or man-made activities. The surveys should be tied to either the U.S. Geological Survey or the U.S. Coast and Geodetic Survey benchmark system used for the underground mine surveys. By using common control points for the surface and underground surveys, accurate vertical and horizontal control can be achieved.

8.2.3 Interpretation and Accuracy of Mine Maps

Mine mapping is a key element in evaluating breakthrough potential. As described in Section 6.4.1.5, the accuracy and completeness of the information on mine maps can vary widely. In times past some mines were not mapped at all, and the accuracy of older mine maps was questionable. Often there are significant differences in the accuracy and completeness of underground mine maps (especially those prepared before 1969) because of the varying requirements associated with their development. Sometimes the horizontal and vertical (overburden) distances between mined barriers and an impoundment are not accurately shown.

Accidents have occurred where an active mine has broken into old/abandoned mine workings that either were not shown on a map or were shown as being hundreds of feet from their actual location. These incidents may have occurred because the complete workings were not surveyed, the area was inaccurately surveyed, the data were not properly recorded, or coal was “robbed” by others after the mine closed. It is important to determine if the mine map being relied upon is current and not an earlier (interim) map. This can be accomplished by cross-referencing dates on the mine map with available production records. Problems can also occur when maps for adjacent mines are not referenced to a common coordinate system or when data from a map are inaccurately transposed from one coordinate system to another. Many potential problems can be avoided by referencing all mine maps to the state plane coordinate system. Unfortunately, some maps and records for older mines have been lost or destroyed.

When mining occurs near an outcrop, subsurface conditions may exacerbate problems related to inaccurate mine maps. It is not uncommon for roof conditions to deteriorate as mining approaches an outcrop. This occurs because the mining encounters less cover, more weathered roof strata, more frequent jointing, and possibly highly weathered joints near an outcrop (sometimes referred to as hillseams, as discussed in [Section 6.4.1.2](#)). Furthermore, the last cut made toward an outcrop typically is not provided with roof support. Because surveyors will not have direct access to the unsupported section of the entry, distances may be estimated rather than directly surveyed. Also, if a roof fall occurs or an area is restricted from access after mining, it may not be accurately surveyed. Dashed lines on a mine map indicate that the area was not surveyed and that locations are determined based on the best available information, which may be estimates from the section foreman’s map.

Areas of secondary recovery mining or partial mining of pillars and barriers are typically not accurately located, as these areas cannot be surveyed. The extent of secondary mining indicated on mine maps is generally based on estimates from foreman reports. Reconnaissance and exploration methods for evaluation of such conditions are discussed in [Section 8.3](#).

8.3 ON-SITE RECONNAISSANCE AND EXPLORATION

The accuracy of available mapping for coal contours and outcrops can vary depending on the age, location and source of the mapping. Therefore, when earthen dams and refuse impoundments are to be constructed over or in proximity to active and abandoned underground mine workings, the accuracy of this mapping information must be verified as part of site reconnaissance studies. The following sections provide a description of surficial reconnaissance and geophysical and geotechnical exploration methods that can be used to confirm the location and configuration of underground mine workings.

8.3.1 Surficial Reconnaissance

Surficial reconnaissance consists of walking the disposal facility site and vicinity (both dam and impoundment areas to be developed) and observing topography, rock and coal outcrops, surface cracks and subsidence features, soil types, vegetative cover, spring discharges, perennial and intermittent watercourse locations, and any other information that may contribute to more complete knowledge of the site. This type of surficial reconnaissance and geologic mapping generally requires an experienced geologist or engineer with knowledge of refuse disposal and embankment design. If possible, the reconnaissance should be conducted during times when vegetation is dormant so that site features are more visible. Additional details regarding the types of features that should be documented during a surficial reconnaissance are discussed in [Section 6.4.2](#).

Test pits can greatly enhance surficial reconnaissance, as areas can be excavated to: (1) determine the relationship of seeps to the coal seam(s), (2) verify coal seam outcrop(s), and (3) establish the depth of weathering, presence of fill, etc. Test pits can be cost effective particularly when active mining operations are nearby and on-site equipment can be employed.

8.3.2 Geophysical Methods

Where there is uncertainty regarding the presence and extent of mining or the accuracy of available mine maps, some geophysical exploration methods can be employed as a logical first step for site evaluation and reconnaissance. Geophysical methods, through detection of anomalies, can indicate whether mine workings are present and if detected mine workings generally correspond to available mine maps. Geophysical methods that have been used for locating mine workings include seismic, electromagnetic and electrical resistivity techniques. A detailed description of these and other geophysical methods is provided in [Section 6.4.4](#). The advantage of geophysical methods is that a large area can be quickly explored, as compared to drilling programs where information is obtained one borehole at a time. Geophysical methods entail the use of sophisticated equipment and data processing techniques. Therefore, these studies should be planned, implemented, and the data interpreted only by persons experienced in this specialty field. Results of geophysical site exploration should be confirmed by subsurface drilling or other independent technique.

Geophysical methods have limitations related to void and mine depths, overburden type and condition, and whether voids contain water. No single method has proven successful in a majority of cases, even where depth and mine void filling is ideal for the method being employed. Thus, geophysical methods should be viewed as a tool to identify potential anomalies that can be further defined by other methods such as drilling.

8.3.3 Long-Hole Directional Drilling

Directional or long-hole drilling generally refers to in-mine drilling operations used for identifying and understanding geological and mining conditions in advance of mining. Directional holes have been drilled for horizontal distances of more than 5000 feet (Kravits and Schwoebel, 1994). Long-hole drilling can also be performed from the surface, independent of mining operations, and thus can be employed near abandoned mines. Advances in directional, long-hole drilling include a technique that can be used for locating or verifying the absence of mine workings. The position of the end of the hole is determined using a surveying tool that is an integral part of the drilling system. The borehole can be guided or steered from underground mine workings or from the surface to determine whether there are mine workings in a particular area. This technique can also be used to advance a hole within the coal seam and roughly parallel to a coal-outcrop line to establish the thickness of solid outcrop barrier around an impoundment site. Reportedly, long-hole drilling can achieve accuracies of better than $\pm 1^\circ$ of azimuth and $\pm 0.25^\circ$ of inclination. Long-hole drilling is also discussed in [Section 6.4.3.9](#). Boreholes associated with such drilling should be properly sealed, as they can become seepage paths or increase breakthrough potential.

8.3.4 Conventional Drilling and Sampling

Drilling boreholes is probably the most effective method for determining the location, extent and variability of subsurface conditions at specific points. The difficulty with drilling boreholes is determining how many are needed to adequately characterize a site and where the boreholes should be located. [Section 6.4.3](#) describes subsurface exploration and in-situ test planning for earthen dams and refuse impoundments. Geotechnical exploration for an impoundment site is much more complicated when there are underground mine workings at or in the vicinity of the site. For this situation, a substantial number of borings is often needed for characterizing conditions near the embankment and impoundment, and sometimes angle or horizontal drilling may be useful. Not only does the accuracy of available mine maps need to be determined, but the nature and variability of the overburden also need to be defined. An advantage of using geophysical methods as a preliminary step in site investigation is that the results of the geophysical work may allow the designer to optimize the number and location of boreholes and minimize associated costs. In general, the scope of the drilling needs to be such that the accuracy of the mapping information can be verified and the geologic, soil, and water conditions can be determined sufficiently to enable evaluation of: (1) the adequacy of barriers

and overburden with respect to breakthrough and (2) assessment of the potential for subsidence to affect the dam. Table 8.3 presents exploration considerations for assessing breakthrough potential at impoundment sites (MSHA, 2003) and also provides a discussion of the use of test pits to verify coal seam outcrops. Table 8.4 presents exploration considerations for outcrop barriers developed by OSM (Kohli and Block, 2007).

Exploration borings that are advanced from an impoundment site into underground mine workings could be a potential breakthrough path if not properly plugged. Guidance related to sealing of boreholes is presented in Section 6.4.3.13.

TABLE 8.3 EXPLORATION CONSIDERATIONS FOR ASSESSING IMPOUNDMENT BREAKTHROUGH POTENTIAL TO UNDERGROUND MINES

1. Identify locations under the reservoir, and around the perimeter of the reservoir, where the conditions appear to be most critical. Verification should be based on the locations where mapping or geophysics indicates that the total cover or the outcrop barrier widths are minimums, and other locations where the competent rock portion of the overburden is reduced.
2. These critical locations should be explored by drilling or test pits. The number of locations explored will depend on: (a) how far the mining is or is expected to be from the impoundment, (b) the level of uncertainty, (c) the results that are found, and (d) the degree of conservatism associated with the design or remedial measures being considered.
 - In an outcrop barrier, the main concerns are to: (1) verify how close to the surface mining has occurred, (2) determine whether the pillars have been first-mined only, and (3) establish whether auger or highwall mining has reduced the size of the barrier. Exploration should be conducted at several of the more critical areas to verify the extent of mining and determine the cover conditions, in particular, the thickness and condition of the rock strata. If the mapping is found to be inaccurate in any of those areas, then additional areas will need to be checked.
 - Where mining has occurred below the level of the bottom of the reservoir (below drainage), the main concern will be to confirm the depth to mining, the mining method, the extent of mining, the characteristics of the overburden, and the size and condition of the pillars.
 - During exploration, evidence should be collected which helps to corroborate available information on the type of mining and characteristics of gob materials, age of mining, presence of water and pools, and past injection of slurry or other materials in the mine workings.
3. Where practical, selected borings that are drilled for other purposes, such as foundation investigation, should be extended to the coal seam level(s) to provide additional points to confirm whether or not mining has occurred. Where longwall or retreat mining has occurred, borings can provide information on mine convergence and gob materials (backfill classification and penetration resistance.)
4. For each area investigated, sufficient information on the geologic conditions (e.g., rock quality, joints, weathering), and the engineering properties of the materials, should be obtained.
5. A sufficient number of vertical drill holes should be drilled at critical locations to bracket the farthest extent of the mining. Where practical, horizontal and angle holes may be helpful in locating and mapping conditions.
6. In determining where holes should be drilled, the lateral extent should consider possible zones of subsidence. The lateral extent of the area impacted by subsidence is larger than the mined area and is generally defined by the angle of draw from mine workings that are in proximity to the impoundment.
7. If the designer determines that multiple seam mining has occurred in the area, information should be collected on the mining in the other seams including mine map overlays and the nature of the interburden between the seams.
8. The extent of augering and highwall mining is usually not accurately mapped and should be evaluated to assess the extent of penetration of the coal barrier.
9. Borehole cameras and imaging systems such as borehole sonar (flooded mine) or laser scanners (dry mine) can be used to obtain additional information about the conditions at mine level, such as mine void dimensions and orientation and rib characteristics, as well as the amount of subsidence or collapse that has occurred, and the conditions at discontinuities intersected by the borehole.

(ADAPTED FROM MSHA, 2003)

TABLE 8.4 OUTCROP BARRIER EXPLORATION CONSIDERATIONS

1. Determine the minimum overburden thickness above the mine workings closest to the mine side of the barrier. Both the rock thickness and the thickness of unconsolidated material should be considered.
2. Inspect the surface area close to the proposed outcrop barrier for natural benches and other surface features (e.g., road cuts) that could reduce the overburden thickness.
3. Verify the correct location of the outcrop on the mine maps using land or GPS surveys. The outcrop may have been plotted by the mine survey or from the topographic maps.
4. Look for evidence of any water seepage above the barrier and from adjacent mine workings. Determine the quantity of discharge and its locations.
5. Determine if there are adits or auger holes in the mine barrier that are not shown on the map.
6. Identify other features that may impact the integrity of the barrier.
7. Look for evidence of subsidence or sinkhole cracks or other zones of weakness in the overburden above the mine workings adjacent to the barrier.

(KOHLI AND BLOCK, 2007)

8.4 EVALUATION OF MINE SUBSIDENCE AND BREAKTHROUGH

Mine subsidence can impact coal refuse disposal facilities directly by decreasing the stability of an embankment or impoundment leading to movement or release of refuse materials and water, or indirectly by affecting the grade or structural integrity of a drainage component. Ways in which mine subsidence can have an adverse effect on a refuse embankment include causing cracking, providing paths for seepage, disrupting internal drains, damaging decant pipes, and reducing free-board. Sinkholes beneath a dam can cause internal erosion that can lead to dam failure. When mine subsidence leads to fracturing or sinkhole development extending to a surface impoundment, the possibility of a breakthrough into underground mine workings is an important consideration. A breakthrough is a sudden, uncontrolled release of water and/or fine coal refuse from an impoundment into an underground coal mine. Even when a slurry impoundment is no longer in use, there may still be potential for a breakthrough if the buried fine refuse remains in a loose, saturated condition.

The ability of overburden strata, outcrop barriers, and mine bulkheads to prevent breakthrough depends on many factors. These factors include:

- Thickness of strata above the mine workings
- Engineering properties of strata above the mine workings
- Width and integrity of the outcrop barrier
- Thickness and integrity of the material above and below the coal barrier
- Hydraulic conductivity of the coal and surrounding strata
- Piping potential of any natural soil, mine spoil, or refuse surrounding the outcrop barrier
- Size, depth and location of mine voids
- Hydrostatic and earth pressures
- Water and fine coal refuse levels
- Flowability of the fine coal refuse
- Presence and orientation of stress relief fractures, rock discontinuities, and weathered joints

- Impacts of any physical disturbance (e.g., landslides, road cuts, auger or highwall mining) on the material in the outcrop area
- Presence of mine pools or slurry within the workings and the effect of slurry injection on the mine floor and barrier

Differential movements associated with mine subsidence, even if they do not represent an impoundment breakthrough concern, need to be evaluated to assess potential effects on surface and subsurface drainage structures. Subsidence and potential breakthrough failure mechanisms should be evaluated based on site-specific data. Collection and evaluation of information and field data on the mine, overburden and disposal embankment may be necessary for evaluating the potential for subsidence and breakthrough and for assessing possible mitigation measures. The need for collecting these data is dependent upon site conditions; however, the data review will minimize assumptions associated with the identification of failure mechanisms.

Table 8.5 presents a summary of guidelines and associated references for evaluating potential impacts from subsidence. Additionally, MSHA (2003) presents guidance for evaluating the potential of breakthrough from impoundments to mine workings and breakthrough prevention measures. The following sections present and discuss information from this guidance document.

8.4.1 Mine Subsidence Considerations

The possible impacts of mine subsidence on an impoundment and mine workings must be evaluated whenever a refuse disposal facility or other impoundment is to be located in the vicinity of existing underground workings or planned underground mining. Subsidence generally entails both vertical and horizontal movement, strain, tilt and curvature and may manifest on the surface as: (1) cracks, fissures or fractures; (2) pits or sinkholes; and (3) troughs or sags. Surface fractures may occur where there are areas of tension or shear stresses in the ground. When the area of surface subsidence is relatively small and the workings are close to the surface (normally 100 feet or less but as deep as 150 feet), the subsidence feature may be of pit or sinkhole size. Larger areas of surface subsidence are referred to as troughs or sags and are typical of deeper and secondary mining operations. Figure 8.1 illustrates the disturbance of geologic strata over mine workings, including some of the following effects (Kendorski; 1993, 2006):

- Floor heave – Upward thrust of the floor in the mine working area.
- Caved zone – Caving of the overburden directly over a mine void and bulking of the caved material leading to support of overlying strata generally extending to a height of 3 to 10 times the extraction thickness.
- Fractured zone – A zone of vertical fracturing and bed separations. Overburden in this zone moves vertically in large blocks along existing joints and new vertical fractures. Typically this zone extends no more than 24 times the extraction thickness above the mine, but can reach 30 times the extraction thickness.
- Main roof – This zone, which is sometimes subdivided into the Dilated Zone and the Constrained Zone, is an area of no significant increase in vertical hydraulic conductivity. This zone has been characterized as extending above the Fractured Zone up to 60 times the extraction thickness.
- Surface zone – Surface cracks are typically present in this zone and are generally limited to areas placed in tension by subsidence. Cracks can be created in dry clayey soil and joints can open in massive sandstones. Such cracks can extend downward to a depth of 50 feet.

Figure 8.2 illustrates the influence of extraction width on subsidence at the surface. For the maximum subsidence to be observed at the surface, the coal extraction width must typically reach the critical

TABLE 8.5 SUMMARY OF GUIDELINES FOR MINING UNDER OR NEAR BODIES OF WATER

Reference	Description	Criterion
Room and Pillar (first mining only)		
Babcock and Hooker, 1977	Minimum Solid Overburden	$10t$ or $5s$, whichever is greater
	Minimum Solid Overburden where competent bed of sandstone or other rock is present.	$< 10t$ or $5s$, provided competent bed is $> 1.75s$
Panel and Pillar		
Babcock and Hooker, 1977	Minimum Solid Overburden	270 feet or $3p$, whichever is greater
	Maximum Width of Extraction Panel (p). For multiple seams, superimpose panels and pillars with panel widths being determined from the depth of the uppermost seam and pillar width being determined by reference to the thickest and/or deepest seam, whichever gives the greater dimension. Where panel and pillar system are employed in upper seam, apply above criterion considering upper seam or body of water.	$p \leq 1/3 H$
Total Extraction		
Skelly and Loy, 1977	Minimum Overburden (H)	$100t$ or ≥ 700 ft, whichever is greater
	Surface Tensile Strain (ϵ_t)	< 0.010
Babcock and Hooker, 1977	Minimum Solid Overburden	$60t$
Kendorski et al., 1979	Minimum Overburden	
	<ul style="list-style-type: none"> • Catastrophic-Size Water Body • Major-Size Water body with Limited Potential 	<ul style="list-style-type: none"> varies from $60t$ to $117t$ varies from $37t$ to $105t$
	Surface Tensile Strain	
	<ul style="list-style-type: none"> • Catastrophic-Size Water Body • Major-Size Water Body with Limited Potential 	<ul style="list-style-type: none"> ≤ 0.010 ≤ 0.015

Note: These guidelines generally apply to the prevention of significant impacts to overburden and inflow into mines. Lower strains than those indicated can cause cracking of embankment dams.

- H = thickness of rock overburden (ft)
 t = average extraction thickness (ft)
 s = entry width (ft)
 ϵ_t = surface tensile strain (dim)

width shown. If the mined width is less than critical, it is termed subcritical, and the amount of subsidence is less than the maximum subsidence experienced with wider extraction areas. If the mined width is greater than the critical width, supercritical conditions prevail, and the subsidence trough will exhibit a flat bottom depression, as shown in Figure 8.2. The figure also shows the angle of inclination between the vertical at the edge of the workings and the point of zero vertical displacement at the edge of the trough, which is termed the limit angle or angle of draw. Depending on the prediction method used, survey standards employed, or criticality of a surface structure, determination of the angle of draw is typically based on a minimal vertical movement of between 0.01 and 0.1 feet (for predictive measures that assume an asymptotic approach to zero such as the tangent-hyperbolic function). The "coal extraction width" can be a result of longwall mining, second mining of pillars, or pillars crushing or punching into the floor.

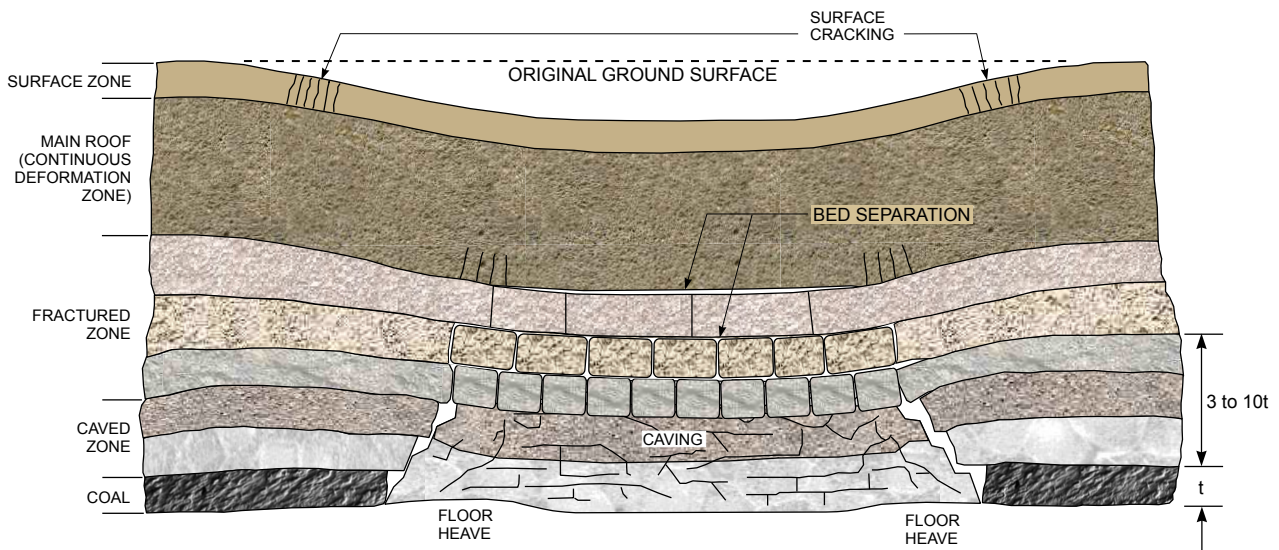

(ADAPTED FROM SINGH AND KENDORSKI, 1981;
PENG AND CHIANG, 1984)

FIGURE 8.1 STRATA DISTURBANCE AND SUBSIDENCE CAUSED BY MINING

Subsidence lowers surface grades and elevations and can affect surface drainage and alter impoundment freeboard. Strains and horizontal displacements associated with subsidence can impact the structural integrity of surface structures such as dams (including internal drains and decants), embankments, and bridges and buried structures such as pipelines and large culverts. Zones of surface tension and compression develop during mining, resulting in horizontal movement profiles that are primarily a function of the extraction width, as depicted in Figure 8.3. The most severe subsidence impacts on many impoundment structures occur where the tensile strain is highest, while for other structures it is the area of greatest tilt or subsidence-induced slope. The existing condition of a structure and slope of the terrain on which the structure is situated also affect subsidence impacts.

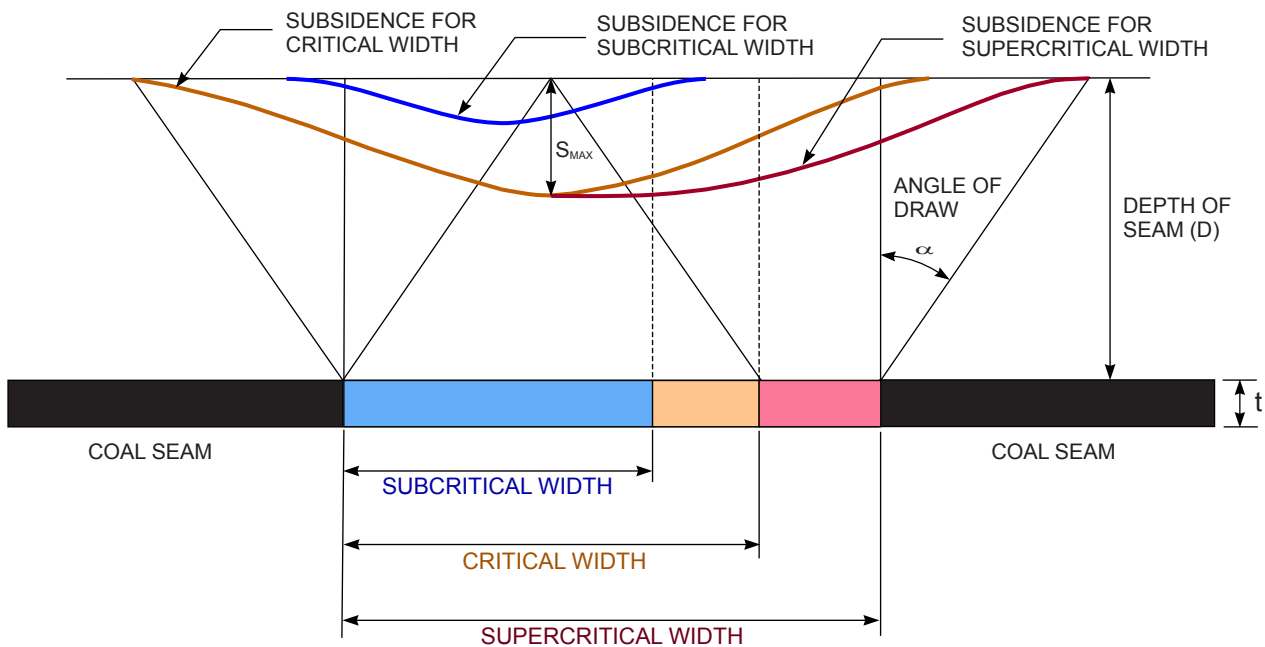

(SINGH, 1992)

FIGURE 8.2 INFLUENCE OF EXTRACTION WIDTH ON SUBSIDENCE

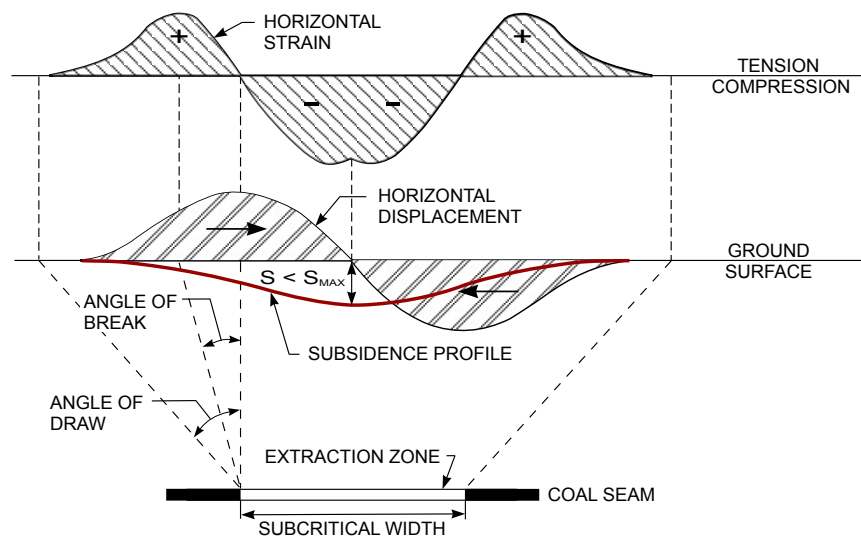

8.3a SUBCRITICAL WIDTH

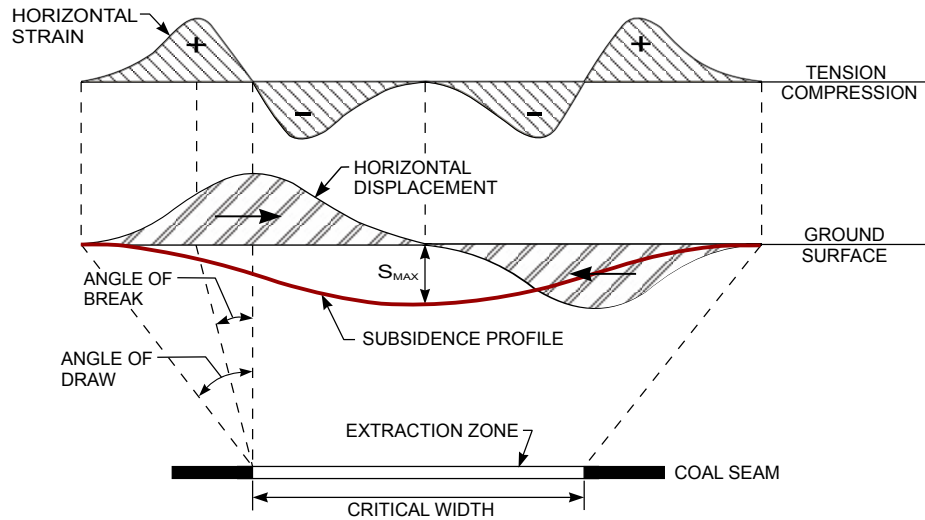

8.3b CRITICAL WIDTH

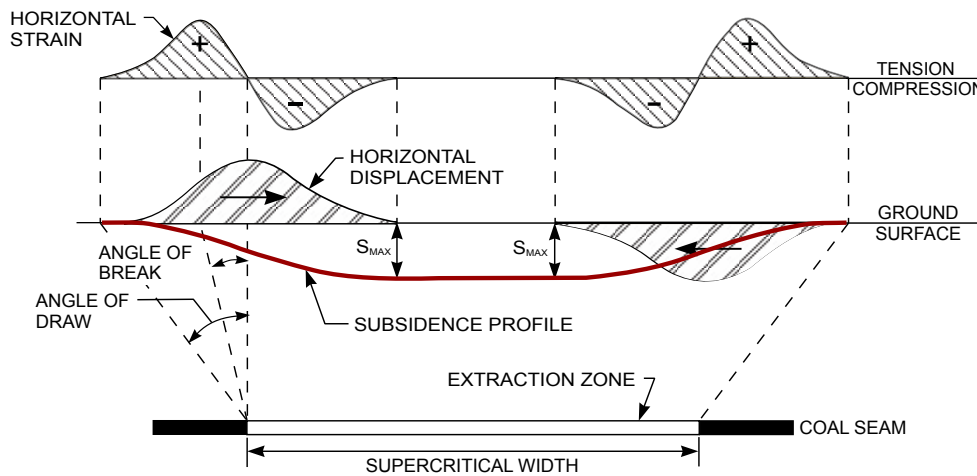

8.3c SUPERCRITICAL WIDTH

(SINGH, 1992)

FIGURE 8.3 DISPLACEMENT AND STRAIN FOR VARIOUS EXTRACTION WIDTHS

For total extraction mining, subsidence follows the advance of the mine workings, and horizontal tensile and compressive strain regions move laterally with the mining, as shown in Figure 8.4. Therefore, determination of the impacts of full extraction mining beneath embankments and impoundments must be based upon subsidence development (i.e., dynamic subsidence) and the associated traveling strain curve and not just the final subsidence profile. Areas of greatest impact generally occur near the boundaries of the extraction zone. Figure 8.5 depicts the ground movements caused by subsidence. Singh (1992) summarizes factors that affect mine subsidence, including: (1) seam thickness, depth, and dip; (2) mine floor, roof and overburden; (3) geologic discontinuities and in-situ stresses; (4) surface topography; (5) groundwater; and (6) percent of extraction, advance rate, backfilling, and elapsed time.

8.4.2 Potential Subsidence and Failure Mechanisms

There are several potential mechanisms that are associated with mine subsidence and mine breakthroughs. Subsidence can occur as a result of caving and fracturing of the mine overburden and migration of the disturbance to the surface (e.g., sinkhole development), pillar crushing, or pillar punching. Also, planned subsidence can occur as a result of: (1) total extraction mining using long-wall methods or secondary mining of pillars or (2) room and pillar mining with partial extraction leaving pillar remnants designed to yield. The condition of the coal and overburden and the mine extraction method will determine the extent to which subsidence will propagate upward toward the surface and the degree of fracturing and deformation that can occur at the surface. Longwall subsid-

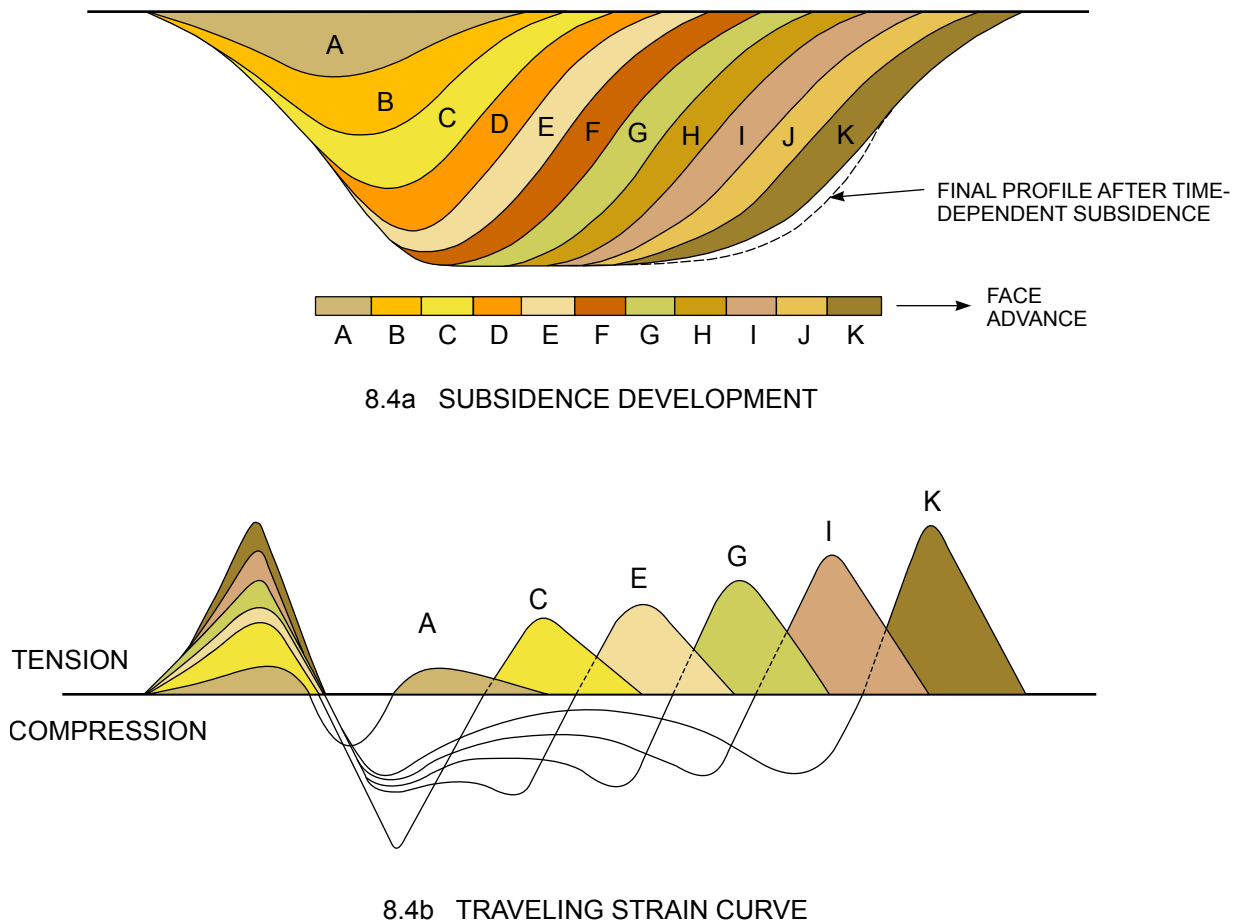

(RELLENSMANN AND WAGNER, 1957)

FIGURE 8.4 DEVELOPMENT OF SUBSIDENCE TROUGH AND STRAINS WITH FACE ADVANCE

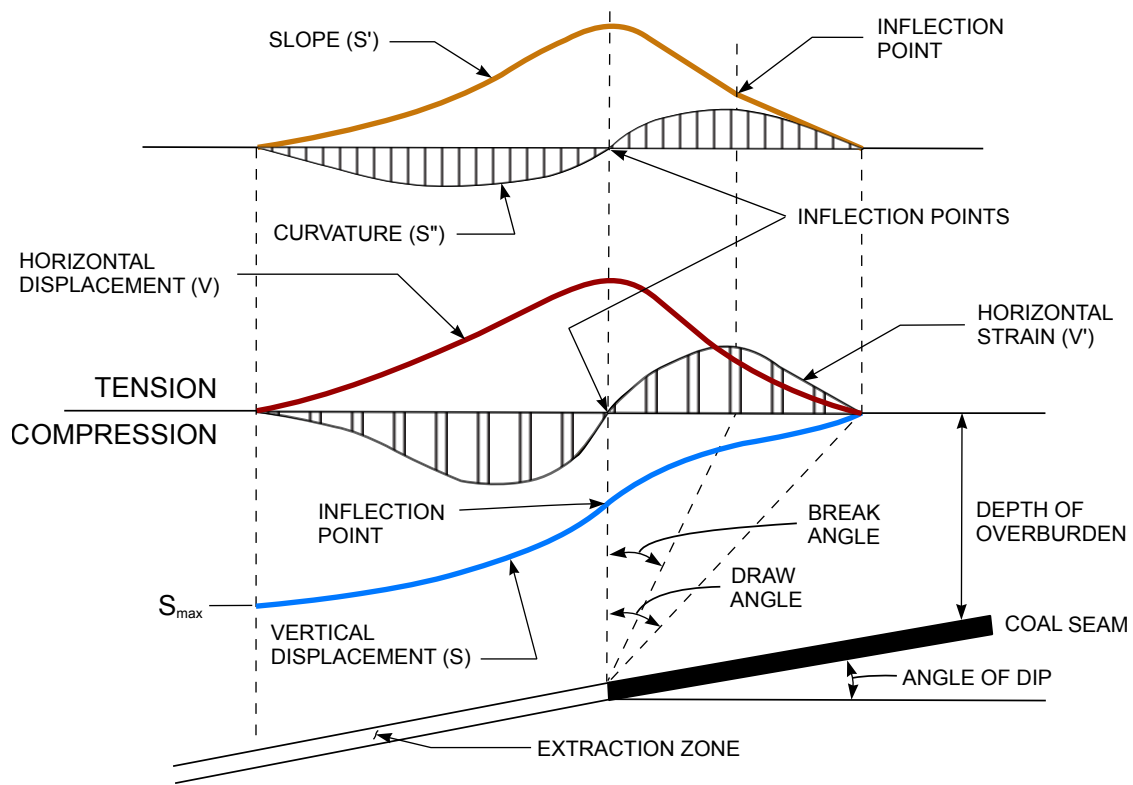

(SINGH, 1978)

FIGURE 8.5 GROUND MOVEMENTS CAUSED BY SUBSIDENCE

ence occurs shortly after mining, but room and pillar subsidence may occur years or decades after mining, as conditions or in-mine support deteriorate.

Subsidence of underground mine workings can lead to breakthrough if an impoundment is located directly over or near the mine. If the caved or fracture zone intersects with the surface or surface soil layer, a breakthrough can occur. The driving force for a breakthrough is the pressure gradient (earth and water pressure) between the impoundment and the underground mine workings. The added weight from the embankment and reservoir, combined with increased seepage heads, increases the stress on the underlying strata. Mechanisms that can cause a breakthrough include internal erosion or piping, outcrop barrier failure, hillside movement and disturbance, mine seal failure, or barrier (coal, soil and/or rock) decomposition. These mechanisms are frequently interrelated and should be carefully evaluated as part of the analysis of the potential for breakthrough.

8.4.2.1 Sinkholes

A sinkhole is a depression or opening in the ground surface above an underground mine void where the mine roof has fractured and fallen/caved and the disturbance has intersected the surface or soil mantle. The fracturing of the mine roof material can eventually extend high enough that an opening, or at least a weakened area, is created at the ground surface, particularly where the overburden is thin. A sinkhole can serve as a direct conduit from an impoundment to underground mine workings. Factors contributing to sinkhole development include: (1) the presence of a mine void, (2) low overburden thickness, (3) mine roof material that is not sufficiently strong or durable to span the mine opening, (4) fractures in the mine roof, (5) unconsolidated soil and weathered rock above the mine roof, and (6) pressure exerted by refuse and/or water at the surface. The action of water flowing through fractured strata can cause deterioration and can enlarge a sinkhole beyond the depth and extent that would occur in the absence of water.

A sinkhole will not develop if the rock strata above the mine are either strong enough to span openings without collapsing, the strata above the mine are thick enough that an arch forms over openings and prevents the collapse feature from propagating to the surface, or the swell of falling rock checks the propagation of the collapse before it affects the mantle of unconsolidated material. One study in Pennsylvania (Gray et al., 1977) found that 81 percent of sinkholes occurred where there was less than 100 feet of cover, with most occurring at 50 to 60 feet of cover. However, there have been unusual cases, such as a sinkhole in Illinois (DuMontelle et al., 1981) where the cover was 165 feet, although the overburden thickness in this case included a substantial amount of glacial till. The mine depth associated with sinkholes reported from mines located primarily in Colorado, Utah and Wyoming (Dunrud and Osterwald, 1980) was generally 10 to 15 times the seam thickness.

Analysis of roof strata to determine if they will indefinitely span mine entries is difficult because: (1) the strength of the rock is not easily defined, (2) the effect of joints on the integrity of the roof (especially at shallow depths) adds considerable uncertainty, and (3) long-term integrity of coal pillars and roof support system can be an issue. For these reasons, the adequacy of the mine overburden to prevent sinkhole development is commonly assessed by applying certain “rule-of-thumb” type guidelines that have been developed based on experience. Guidelines developed by Babcock and Hooker (1977) are illustrated in [Figure 8.6](#). These guidelines are generally considered to be conservative, and they should be carefully reviewed before detailed analyses to assess the potential for subsidence and related differential movement and strain are performed. Mine development work has been performed and production areas have been successfully implemented following the guidelines shown in [Figure 8.6](#). However, where subsidence has the potential to affect a high-hazard-potential impounding embankment or to allow a breakthrough that could affect the safety of miners or the public, these guidelines should be used only in conjunction with more rigorous site-specific analysis.

With respect to sinkholes, the guidelines recommend for first mining only that the thickness of solid strata should be equal to at least 5 times the entry width or 10 times the extraction height, whichever is greater. These guidelines are consistent with findings that compression arches in overburden are normally stable if the mining width is limited to one-fourth to one-half of the overburden height. In other words, the compression arch is typically stable if the thickness of the rock strata above the mine is from 2 times (strong strata) to 4 times (weaker strata) the entry width. Adding a margin of safety, the “rule-of-thumb” is that the overburden thickness should be 5 times the entry width. Similarly, the criterion related to the extraction height is based on adding a margin of safety to the observation that the height of collapse above a mine entry generally does not exceed 3 to 5 times the extraction height, likely because of the swell of the collapsed material.

A key point in the use of these guidelines is that the strata thickness refers to “solid overburden strata.” Soil, weathered rock, or weak rock should not be included in the solid strata thickness since they may not provide the strength needed to resist sinkhole development (MSHA, 2003).

The guidelines in Babcock and Hooker (1977) suggest that a lesser strata thickness may be acceptable if the overlying strata consist of competent rock (e.g., competent bed of sandstone or similar material) with a thickness of at least 1.75 times the entry width. Competent rock is normally taken to mean a homogeneous, massive layer of sandstone or limestone (MSHA, 2003). This guideline is based on analyses of the overlying strata as a beam with minimum tensile strength (20 psi). While any intact piece of rock will likely exceed this tensile strength, joints or discontinuities will reduce the effective strength of the beam. Because the potential impact of joints and weathering, especially near an outcrop, cannot be modeled with confidence, this approach should normally not be used for a critical subsidence or breakthrough situation. Furthermore, there is a possibility that the strength of the overlying strata will deteriorate over time due to seepage and weathering, especially as the mine pool level rises.

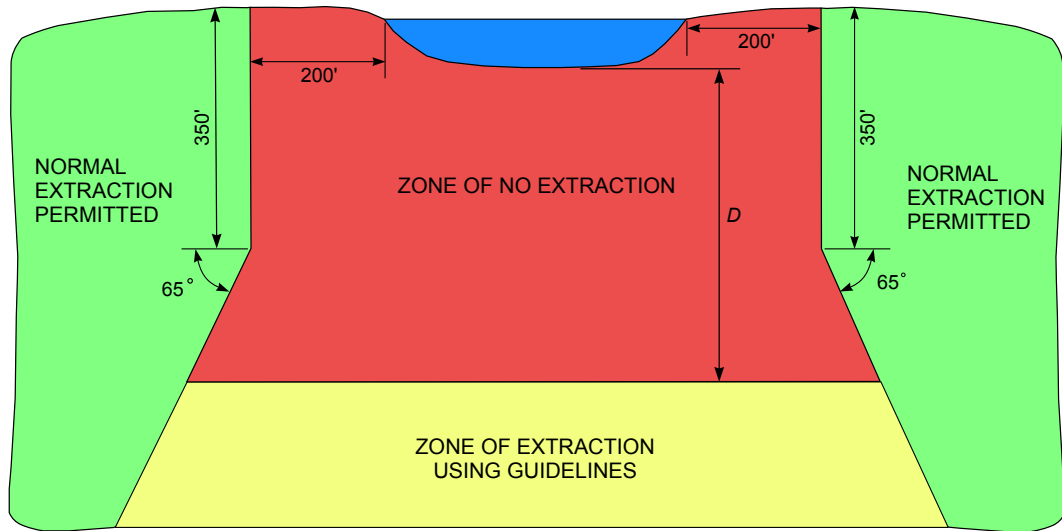

ROOM AND PILLAR	$D = 5s$ or $10t$, whichever is larger	s = maximum entry width (ft)
PANEL	$D = 3p$ or 270 feet, whichever is larger	p = panel width (ft)
TOTAL EXTRACTION	$D = 60t$	t = extraction height (ft)

8.6a SAFETY ZONE BENEATH BODY OF SURFACE WATER

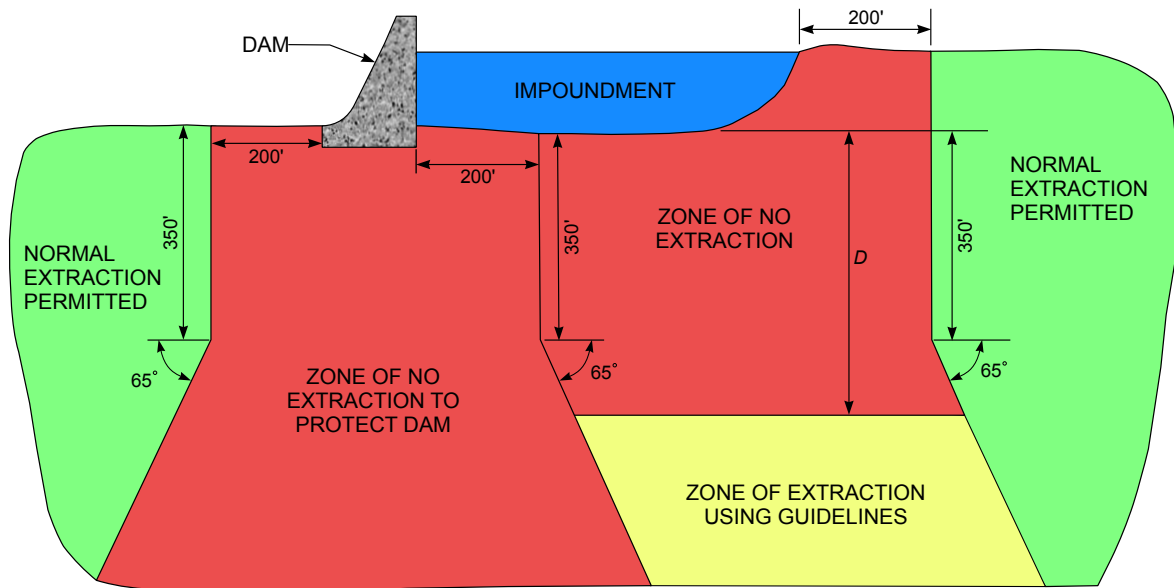

ROOM AND PILLAR	$D = 5s$ or $10t$, whichever is larger	s = maximum entry width (ft)
PANEL	$D = 3p$ or 270 feet, whichever is larger	p = panel width (ft)
TOTAL EXTRACTION	$D = 60t$	t = extraction height (ft)

8.6b SAFETY ZONE BENEATH DAM AND IMPOUNDED BODY OF SURFACE WATER

NOTE: THE ZONE OF NO EXTRACTION TO DEPTH "D" IS PRESUMED TO COMPRISE SOLID ROCK STRATA (IF MATERIAL OTHER THAN SOLID ROCK COVER IS INCLUDED, IT IS NECESSARY TO DEMONSTRATE THE NATURE AND PERMEABILITY OF SUCH MATERIAL). THE ZONE OF NO EXTRACTION MAY BE INCREASED OR DECREASED, IF JUSTIFIED BY LOCAL OBSERVATION AND/OR EXPERIENCE.

FIGURE 8.6 SAFETY ZONE GUIDELINES FOR MINING IN THE VICINITY OF DAMS AND IMPOUNDEMENTS

In guidance for evaluating breakthrough potential, MSHA (2003) indicates that any location where the cover over a mine entry is less than 100 feet of solid strata (especially at locations near the outcrop where additional weathering and stress relief has occurred) is a concern for sinkhole development. Accordingly, if sinkhole development cannot be reliably ruled out, preventive measures should be considered.

8.4.2.2 Pillar Failure

Loss of support due to coal pillar failure causes a mine roof to sag or collapse. This can create or open fractures in the overburden. These fractures may cause a roof fall and consequent sinkholes, or the fractures may create zones where internal erosion can occur. Furthermore, failure of one pillar transfers the load to surrounding pillars and may lead to progressive pillar failure (sudden or gradual) or excessive displacements over a relatively large area.

Pillar crushing occurs when the load on a pillar exceeds its strength. This can be caused by existing loads, additional loading from impounded slurry and/or water, loss of strength in the coal from chemical decomposition or from slow oxidation, mine fire, or loss of buoyant pressure resulting from a lowered mine pool. In addition to pillar strength, the pillar width to height ratio (w/h) is also important (Mark, 2006). For “slender” pillars ($w/h < 4$), failure often results in nearly complete loss of load-bearing capacity, sometimes with sudden and total collapse. Pillars with w/h between about 4 and 10 are largely elastic with a possible plastic core, and failures tend to occur gradually with post-failure residual strength essentially constant. The pillars deform until they have shed enough load to stop the process. Pillars with w/h greater than 10 (referred to as “squat”) have a plastic core and may strain harden once the loss of initial strength due to crushing or yielding of the outer elastic portion of the pillar occurs. After this initial crushing, the pillars gain strength as they deform. The implications for surface structures of the failure of slender pillars with shallow cover are much more significant than those associated with yielding of squat pillars at great depth.

A number of formulas for analyzing the strength of a pillar have been developed, and computer programs for performing pillar analyses are available. One example is the program ARMPS (Analysis of Retreat Mining Pillar Stability) developed by National Institute for Occupational Safety and Health (NIOSH). This program uses the Mark-Bieniawski formula to determine pillar strength, and it has the capability to account for loadings on barriers and abutment pressures.

Pillar stability formulas can be divided into two categories – analytical and empirical. Analytical formulas require extensive material testing, an understanding of loading under varying conditions, and a safety factor (typically about 2) based on knowledge and understanding of all variables. These relationships are best applied by engineers who are experienced in mining rock mechanics. One such relationship, Wilson’s equation, which is one of the first analytical models developed for estimating pillar strength, is directly calculated, thus making it more flexible and adaptable to actual conditions than any empirical equation. It can be used to estimate the stress distribution from the edge of a pillar to the center based on the confined core theory (Wilson and Ashwin, 1972). Wilson’s equation uses the Mohr-Coulomb failure criterion for modeling the coal and surrounding rock; however, at high confinement (high w/h ratio) coal strength is not linear with the result that it overestimates pillar strengths. Scovazzo (1995) modified Wilson’s equation to incorporate more appropriate coal and rock failure criteria, specifically those presented by Kalamaras and Bieniawski (1993).

The most commonly used pillar stability formulas are empirical equations where few parameters need to be defined. Since empirical equations are based on statistical analysis of failures and successful designs, a stability factor (not to be confused with safety factor) is employed. One commonly used empirical equation is the Mark-Bieniawski formula. For the Mark-Bieniawski formula, the recommended stability factor is 1.5 for mines less than 750 feet deep (Mark, 2006). A smaller stability factor

is generally used for mines greater than 750 feet deep; for example, a stability factor of 0.9 is used for pillars with over 1,250 feet of cover. These recommended stability factors are based on the assumption of equal area loading. Empirical equations are applicable to specific mining regions and coal seams and should not be applied outside the region for which they were developed unless statistical analyses are performed for the region in which the equation is intended to be used. While some long-term pillar instability can be tolerated in certain mining situations, impoundment designers should consider a higher margin of safety for overburden support and control of detrimental differential movements within the dam and foundation.

Conservative coal strengths based on statistical analysis of failure should be used for pillar failure analysis. Laboratory tests for verifying the strength of the coal can be conducted, although this rarely occurs and is not encouraged. The limited use of testing is in part due to the scatter typically encountered in uniaxial rock tests, a problem that is exacerbated by coal cleating and softness, which make test samples difficult to prepare. A laboratory testing program should include sufficient samples and statistical analysis to verify that data are reliable. As a result, the mass uniaxial compressive strength of coal is often assumed to be 900 psi.

The uniaxial compressive strength of coal determined in the laboratory is many times the in-situ strength of coal in a pillar. This size effect is caused by flaws in the coal that are present in the larger mass of the pillar but not in sample sizes tested in the laboratory. It would take test samples with the impractical minimum dimension in the range of 3 feet (Pariseau, 1975) to 5 feet (Bieniawski, 1968) for accurate determination of the mass uniaxial compressive strength of coal. The most accepted method for reducing laboratory compressive strengths for coal to reflect in-situ strength of the coal was developed by Hustrulid (1976) and is recommended by Bieniawski (1992) for use with his pillar formula.

In any analysis of pillar stability, it is best if the method being used is calibrated to conditions at the subject mine. Thus, the model should be applied to a number of locations in the mine to determine how well it reflects actual conditions or the actual performance of mine pillars. Pillar analysis is more complicated when multiple seams are mined. In such cases, the loading conditions are much more complex due to load transfer and the potential for stress concentrations. Simplified software models, such as LAMODEL, are available for performing this type of analysis. Higher pillar stability factors should be used for multiple seam analyses to account for the additional uncertainty. Both LAMODEL and ARMPS are available from the NIOSH web site.

8.4.2.3 Pillar Punching (Floor Failure)

Pillar punching (pillar foundation failure) occurs when a pillar pushes into the mine floor allowing the roof to sag. This sagging can create fractures and/or open existing joints in the overburden. If the punching occurs over a large area, the surface will be affected in a similar manner (normally without bed separation) to the situation where total extraction of a thinner seam has occurred.

Pillar punching occurs when the load on a pillar exceeds the bearing capacity of the mine floor beneath it. Pillar punching can be caused by existing loads, saturation of the floor material causing softening and loss of strength, additional loading from impounded slurry and/or water, and loss of buoyant pressure from a lowered mine pool.

A key factor to consider in evaluating the potential for pillar punching is experience elsewhere in the mine. A review of floor and pillar performance data, particularly for wet conditions, should be made as part of foundation bearing capacity analyses for evaluation of pillar punching. It may be appropriate to reduce the floor strength when both slender pillars and wet conditions are present or are anticipated as the result of construction of an impoundment. Additional information on pillar punching and associated floor heave can be found in Ganow (1975) and in Adler and Sun (1968).

8.4.2.4 Outcrop Barrier Failure by Shear or Punching

In an outcrop barrier situation, a potential failure mode that must be considered is whether the pressure from water and/or slurry in the impoundment may become high enough to overcome the shear strength that is holding in place the plug of material separating the impoundment from the mine works. Failure can occur through the coal seam itself, through the strata above the coal seam, through a weakened floor layer, or along an interface between strata. [Figure 8.7](#) illustrates a typical outcrop barrier cross section, including the coal barrier, jointing and stress relief fractures. Surface features such as slope instability and regrading for access roads are also shown on the figure.

Analysis of this failure mode for a postulated plug separating the impoundment from the mine involves comparison of the cumulative force tending to push the plug into the mine to the available resistance from shear forces around the perimeter of the plug. The pressure driving the plug is normally taken as the hydrostatic head from the impoundment plus applicable lateral earth pressure from settled fines. A major issue with this type of analysis is judging what to use for the shear strength along the top, bottom and sides of the plug. Factors such as the presence of weathered joints, the presence of cleats in the coal, the softening of the floor from saturation, and the difficulty of obtaining test data can result in uncertainties with respect to shear strength. Furthermore, as seepage into the mine occurs, the strength along potential shearing surfaces may degrade over time, and, if sloughing or a roof fall occurs, the thickness of the plug may be reduced. Additionally, the potential hydraulic gradient across the plug must be carefully considered, as water pressures may be elevated on planes of discontinuity within the plug and present a more severe loading condition than at the plug boundary. Given these uncertainties, any shear-type failure analysis should be based upon conservative values for shear strength and a conservative factor of safety of at least 2.0 (MSHA, 2003).

8.4.2.5 Internal Erosion

Internal erosion, or piping, is the movement of material (typically soil particles) under seepage forces, and it can occur where the gradation is such that particles are dislodged and carried along by seepage and drag forces. When soil overlies rock, movement of material can occur along or into joints, stress relief fractures, or subsidence fractures. [Figure 8.7](#) illustrates typical conditions encountered near a coal seam outcrop where weathered joints may represent seepage pathways from a future impoundment. The presence of stress relief fractures or subsidence fractures would exacerbate the concern for seepage and internal erosion. Seeping water creates a drag force on the material that it is seeping through or around. If this drag force is greater than the frictional or cohesive forces holding material particles in place, they will be transported by the seeping water. As smaller particles are carried away, additional flow occurs, increasing the drag force and dislodging even larger particles. The process can continue until a channel (also referred to as a “pipe”) is formed. Piping into foundation discontinuities can lead to failure of an embankment. In a breakthrough situation, where the source of the seepage is an impoundment and internal erosion occurs through the material between the pool and the mine workings, the pipe can gradually enlarge and lengthen to the point where there is a significant discharge into the mine. Piping is dependent on the type, gradation, consistency, and cementation of the intervening material; relative hydraulic conductivities of the materials along the critical seepage front; and the hydraulic gradient.

One technique for preventing internal erosion is to incorporate filter layers (material with grain-size distributions that prevent particles from moving along a seepage path) at critical locations. Granular filter material or various geosynthetic materials can be used for this purpose. Filter criteria are discussed in [Section 6.6.2.3](#). Also, the gradient can be reduced by using lower-hydraulic-conductivity materials along the upstream portion of the seepage path to increase head loss before the water reaches a critical zone. Excess water pressure can also be controlled by providing drainage to reduce pressures upstream of more erodible zones, such as by installing an internal drain protected by filters.

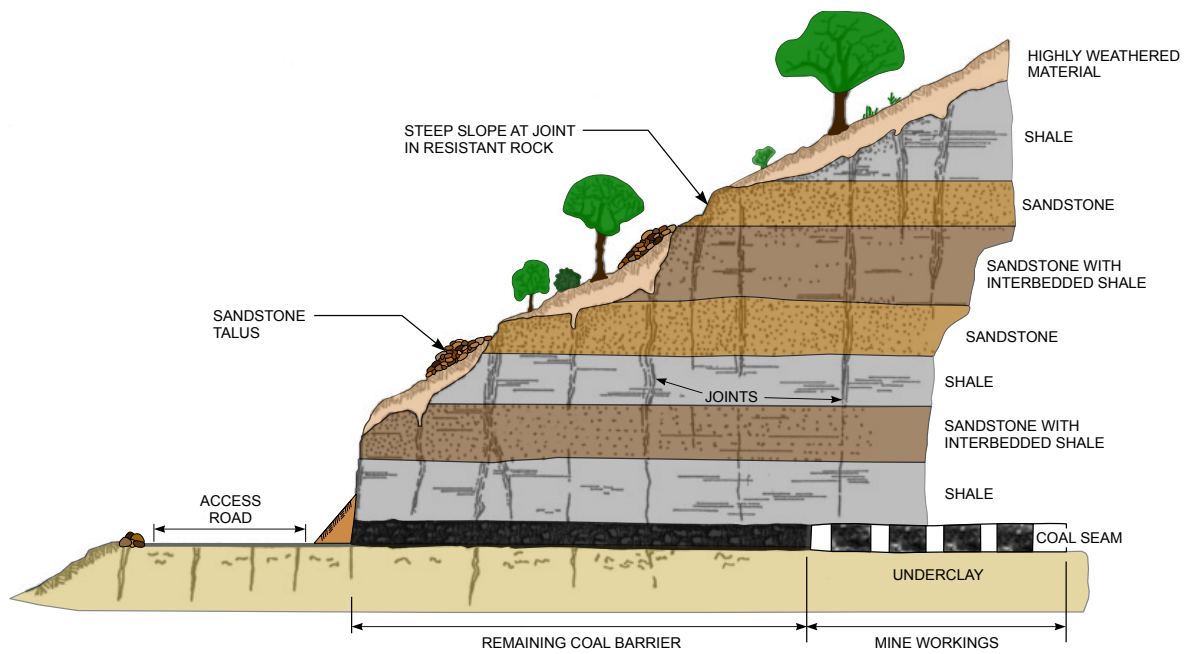

(ADAPTED FROM SAMES AND MOEBIS, 1992)

FIGURE 8.7 HILLSIDE DISTURBANCE AT COAL OUTCROP

In breakthrough situations, seepage into an underground mine can occur through the roof, floor, or coal seam. If the material at the location(s) where the seepage enters the mine is weathered, fine-grained, or loosened as coal may be along a face or rib, then the force of the seeping water may carry particles away and/or cause the in-situ material to slake or unravel. Over time, this can cause the area to weaken, slough, or progressively deteriorate. This is especially a concern near an outcrop barrier, where the internal erosion could cause the ground to give way or a pipe to form through the affected zone. Either situation could lead to an uncontrolled hydraulic connection between an impoundment and the mine workings.

Whenever seepage is flowing outward and exiting at an unconfined surface, as may be the case near the toe of a dam or impounding embankment, the value of the critical gradient with respect to piping is approximately one. However, when seepage is generally horizontal, such as through a rib, or vertically downward, such as through the mine roof, internal erosion can develop under smaller gradients.

Determining the hydraulic gradient between an impoundment and a mine requires accurate characterization of the permeabilities of the intervening materials. Near an outcrop, the seepage may be governed by flow along weathered joints and thus may be difficult to characterize and model. Gradients can be estimated by drawing flow nets or by using a finite element seepage program. Once the gradient has been estimated, the effect of the seepage force on the seepage medium can be determined. The seepage force, per unit volume of seepage medium, is equal to the product of the gradient and the unit weight of water. Whether the medium material will be dislodged by a combination of seepage and gravity forces depends on the frictional and cohesive strength of the material.

Cohesionless soils, particularly silts and fine sands, are most susceptible to piping. Clays are more resistant to piping because the cohesive strength of these soils helps to prevent particles from being carried away. However, clayey soils are not immune to internal erosion, especially if they abut open-

graded materials, open joints or fractures. Also, soft rocks, such as weakly cemented sandstones, have been associated with piping failures. Even shales, which are usually considered resistant to piping, have developed piping voids under conditions of very high gradients (Sowers and Sowers, 1970). In these unusual cases involving rock strata, weaker characteristics of the rock mass presumably led to pathways of increased seepage that intersected and then led to piping of more erodible materials.

If the materials between the mine works and an impoundment are prone to internal erosion or are sensitive to progressive deterioration, then the impoundment should be designed: (1) with suitable filters and drains so that seepage can be collected and released in a controlled fashion, (2) with seepage barriers so that pressures are minimized, or (3) with some combination of these two approaches.

8.4.2.6 Bulkhead Failure

If there is a mine opening in a potential breakthrough area, then the potential for failure of the bulkhead used to block the mine opening must be evaluated. Depending on their thickness and shape, bulkheads can fail when the pressure acting on them causes the bending or shear strength of the bulkhead material to be exceeded. Bulkheads can also fail if the material that they are anchored or keyed into is not strong enough to resist the applied pressures and the pressures from water seeping around the bulkhead, or if the bulkhead is not adequately anchored to the surrounding rock strata. Hydraulic fracturing within floor strata can aggravate seepage and transmission of pressures resulting in the typical recommendation to remove underclay/claystone at bulkhead locations. Analysis of bulkheads is addressed in [Section 8.5.2](#).

8.4.2.7 Trough Subsidence and Subsidence Cracks

If room and pillar workings are located near the footprint of an impoundment (with inadequate stability factors on the remaining pillars), or if either longwall mining or secondary mining of pillars has occurred, an analysis of the potential impact of trough subsidence should be performed. In this situation, zones of tension and compression stress or deformation extend from the mine workings to the ground surface. The area at the ground surface affected by total extraction mining is typically larger than the mined area and is related to the draw angle. The assumed draw angle should be consistent with local experience, with past subsidence associated with mining in the coal seam, site topography, and the method of mining.

The effect that subsidence has on steep natural slopes is a matter of debate (Luo et al., 1996). It appears that the effect is greater than the generally accepted regional angle of draw and is dependent upon local geologic conditions and the direction of mining. The approach of mining from the downslope and towards the upslope appears to result in the greatest horizontal displacement and accompanying stress.

If mining is approaching an impoundment, operations should be terminated at a point where ground deformations will not adversely affect the impoundment. It is rare for the angle of draw to exceed 25° in the U.S., and typical values range from 10 to 25°. In the Northern Appalachian Coalfield, the maximum angle of draw is normally 25°, while in the Black Warrior Basin and Southern Appalachian Coalfield, it is typically around 12°. Work by Scovazzo (2008) at three mines in the Arkoma Basin places this value at 19°. For the Illinois Basin, the angle of draw typically is in the range of 20 to 25° in the southern portion, increasing to 30° in the northern portion as glacial till thickness increases. The angle of draw varies with the dip of the coal seam and the slope of the ground surface and decreases as the percentage of hard rock (sandstone and limestone) in the overburden increases. No pattern for the western U.S. has been identified.

For total extraction mining (longwall mining or secondary mining of pillars) directly below an impoundment, the U.S. Bureau of Mines (USBM) guidelines provided in Babcock and Hooker (1977)

indicate that the amount of cover should be at least 60 times the mining height, as illustrated in Figure 8.6. This guideline was based on studies that looked at disturbance of the rock strata, and the change in the hydraulic conductivity of these strata, above mined areas. Data indicate that it is unlikely that the rock strata above an area of total extraction mining will be disturbed for more than 25 to 35 times the mining height. This thickness guideline (Babcock and Hooker, 1977) is based on the concept of a constrained zone. When total extraction occurs, cracks and joints open at the surface and in the mine roof, but if the overburden is thick enough, the induced stress is absorbed or resisted without fracturing. It should be noted that the Babcock and Hooker (1977) strata-thickness criterion is for evaluation of the potential for developing a hydraulic connection between the surface and the mine; it does not address the potential for other adverse effects such as tensile strains at the surface and loss of freeboard.

Another USBM research report titled, *Criteria for Determining When a Body of Surface Water Constitutes a Hazard to Mining* (Kendorski et al., 1979), recommends cover thicknesses greater than 60 times the mining height when the mining height is less than 7.5 feet. For example, this report recommends that the overburden thickness should be 71, 80, 95, and 117 times the mining height for mining heights of 6, 5, 4, and 3 feet, respectively. The report also indicates that, where inflow can be tolerated, the thickness of cover can be reduced if certain types of strata (e.g., claystone or shales that are less prone to cracking and have low hydraulic conductivity) are present.

The preceding guidelines refer to bodies of surface water and do not specifically consider mitigating factors or measures such as fine refuse deposits that may be associated with a slurry impoundment. These guidelines are important historical literature and should be reviewed as part of initial evaluations; however, it is recommended that subsidence analyses and prediction models be used for evaluating potential deformations and strains on embankments and impoundments. On the basis of these analyses, smaller overburden buffers than identified in the aforementioned references may be sufficient to prevent a breakthrough to a reservoir or slurry impoundment and may satisfactorily limit impoundment leakage/seepage.

A number of subsidence prediction models are available. Two commonly used models include SDPS (Surface Deformation Prediction System) developed at Virginia Polytechnic Institute and State University and CISPM (Comprehensive and Integrated Subsidence Prediction Model) developed at West Virginia University. These programs can be used to estimate surface subsidence and ground strain caused by mining. Two cautions are offered concerning the use of these types of programs: (1) they should only be used for the type of topography and mining conditions for which they were developed and (2) the strain computations by these programs typically do not account for strain concentration along existing discontinuities. Concerning the second point, studies have shown that site topography may have a substantial effect on the development and concentration of horizontal strain.

Furthermore, where the confinement and continuity in the overburden is diminished, such as on hillsides and in highly weathered and fractured material, the tensile strain that is induced by mining may accumulate along one or more of the joints rather than being more evenly distributed. This can be significant in subsidence and breakthrough potential evaluations where open joints can provide seepage pathways. For total extraction mining, the strata and ground surface above the mine are affected regardless of the mining depth, and the effect of tensile strains and strata disturbance on dam stability and breakthrough potential should be evaluated.

8.4.2.8 Failures Related to Auger and Highwall Mining

Auger or highwall mining openings in an abutment can have adverse effects on an impounding embankment. Deformation of the abutment and embankment can occur if the webs between the holes deteriorate or fail. The holes can also provide seepage paths. Breakthroughs can occur through auger or highwall mining holes, through the coal remaining at the ends of auger holes, or as a result

of the collapse of these holes. The importance of identifying the locations of these holes during site exploration cannot be overemphasized. During highwall reclamation these holes are typically covered without backfilling. If they are not discovered and accounted for in the impoundment design, then seepage pressures under high impoundment head can cause movement of backfill and water into auger holes. If the auger holes are accidentally connected to the mine, then there is a direct path for a breakthrough or piping. If the auger holes were terminated close to the mine workings, the remaining coal barrier can potentially fail in a shear or punch-type mode. Also, the narrow pillars or webs of coal between these holes may be marginally stable and may subsequently deteriorate and collapse, resulting in highwall instability and ground deformations that could adversely affect the embankment or lead to a breakthrough. NIOSH has a computer program (ARMPH-HWM) that performs an empirical analysis of highwall mine pillars.

8.4.2.9 Hillside Movement or Disturbance

Hillside movement and disturbance (landslide, creep, or human impacts) can occur at and above a coal outcrop. Weathering tends to reduce the strength of surface soils and rocks while gravity provides a driving force to move soil and rock down the hillside. Surface mining (contour mining) and site development activities, such as road and channel construction, can accelerate the process through removal of soil and rock from the hillside or by aggravating or causing landslides. Any movement or removal of soil and rock from the hillside can reduce and/or disturb the outcrop and overburden barriers between the underground mine and an overlying impoundment, thus contributing to the occurrence of a sinkhole, internal erosion, or shear-type failure. [Figure 8.7](#) illustrates the effect of hillside disturbance on the coal outcrop barrier.

8.4.2.10 Mine Blowout

A mine blowout occurs when water impounded in an underground mine breaks out through either a sealed mine opening or a thin section of the coal outcrop barrier. Such a blowout may be a secondary consequence of an impoundment breaking into an underground mine. Additionally, a mine blowout in an impoundment watershed may represent an inflow source that should be considered in impoundment design. Such an event could cause a significant amount of water to flow into the impoundment, damage impoundment structures, and potentially affect impoundment safety. A guidance manual for design published by the Office of Surface Mining (OSM) is, *Outcrop Barrier Design for Above Drainage Coal Mines*, by Kohli and Block (2007). This document presents compiled information on case histories as well as design studies by Pearson et al. (1981). If seepage from an underground mine is occurring at an embankment or impoundment site, the conditions and potential effects should be evaluated. As a minimum, the facility design should account for collecting seepage and discharging it in a controlled manner that will not adversely affect the embankment or other facility structures.

8.4.2.11 Seismic and Blasting Events

Typically, earthquakes and surface blasting do not affect underground mines. The exception is when a fault crosses through a mine or when surface waves can affect the stability of the portals at or near their contact with the surface. The presence of an active fault passing through a U.S. coal mine is not a situation that normally occurs. If such a fault is identified, it would be necessary to conduct comprehensive stability analyses not just for the mine but also for the associated surface facilities including the refuse embankment and impoundment. Bhabdaru and Arora (1987), Nicholls et al. (1971), Rupert and Clark (1977), Fourie and Green (1993), and Fernandez and Van Der Heever (1996) describe blasting and earthquake impacts on mines.

When blasting is planned within 500 feet of an active underground mine, the Surface Mining Control and Reclamation Act of 1977 requires that the Operator's blasting plan be approved by OSM (or appropriate state agency) and MSHA. Blasting regulations are provided in 30 CFR §

780.13 and 30 CFR § 816.61 through 816.68 and also 816.79. State criteria may also be applicable. The blasting plan should be prepared by a professional licensed in the state where the blasting is to be performed. Potential concerns when an impoundment is present include fracturing of abutments, impacts to pipes and other rigid structures, or possibly upstream construction. Where an impoundment is present, the potential impacts should be evaluated, and monitoring of particle velocity with a seismograph may be appropriate. [Section 6.6.7](#) addresses potential blasting impacts on impoundment structures.

8.4.3 Mine Subsidence Potential and Analysis

8.4.3.1 Pillar Evaluation and Analysis

For room and pillar mining, subsidence potential can be evaluated through analysis of the overburden stress imposed on coal pillars and comparison of this stress to the pillar strength. To determine the average stress on a coal pillar, the tributary area approach may be used with the assumption that the overburden pressure increases at a rate of 1.1 psi per foot of depth:

$$S_p = 1.1 H [(w + B)/w][(L + B)/L] \quad (8-1)$$

where:

- S_p = average pillar stress (psi)
- H = depth below ground surface (ft)
- w = pillar width (ft)
- L = pillar length (ft)
- B = opening width (ft)

Other assumptions inherent in this formula include:

- The coal seam is subject only to vertical pressure.
- Each pillar supports the column of rock and other overburden overlying the pillar and a proportionate share of surrounding openings.
- The load is distributed uniformly over the pillar cross section.

Most empirical pillar equations have been developed and the results statistically analyzed based on these assumptions, particularly with respect to tributary area loading. Therefore, empirical equations should only be used for uniformly distributed tributary loading. Numerical models such as LAMODEL can be used to analyze non-uniform pillar loading (transfer of load to flanking barrier pillars). However, if pillars are to be analyzed without considering tributary area loading, then the pillar loads should be determined through a detailed rock mechanics analysis using numerical modeling software. Typically, a higher safety factor is used for such a pillar analysis because of uncertainty as to the loading and the variability in the numerical methods typically employed.

Pillar strength formulas used for design of ground control measures are discussed in Bieniawski (1992). For subsidence evaluations for coal refuse disposal facilities, pillar strength formulas consistent with conditions in the underlying mine should be adopted; otherwise formulas applicable to local mines should be employed. Several empirical formulas that have been used to determine pillar strength are presented in [Figure 8.8](#). The Pittsburgh Coal seam with a pillar height of 10 feet is used as an example of the influence of the width to height ratio on the overall pillar strength. The potential for subsidence can be determined by dividing the pillar strength by the pillar load. An important consideration when comparing the pillar strength formulas is the value of the recommended stabil-

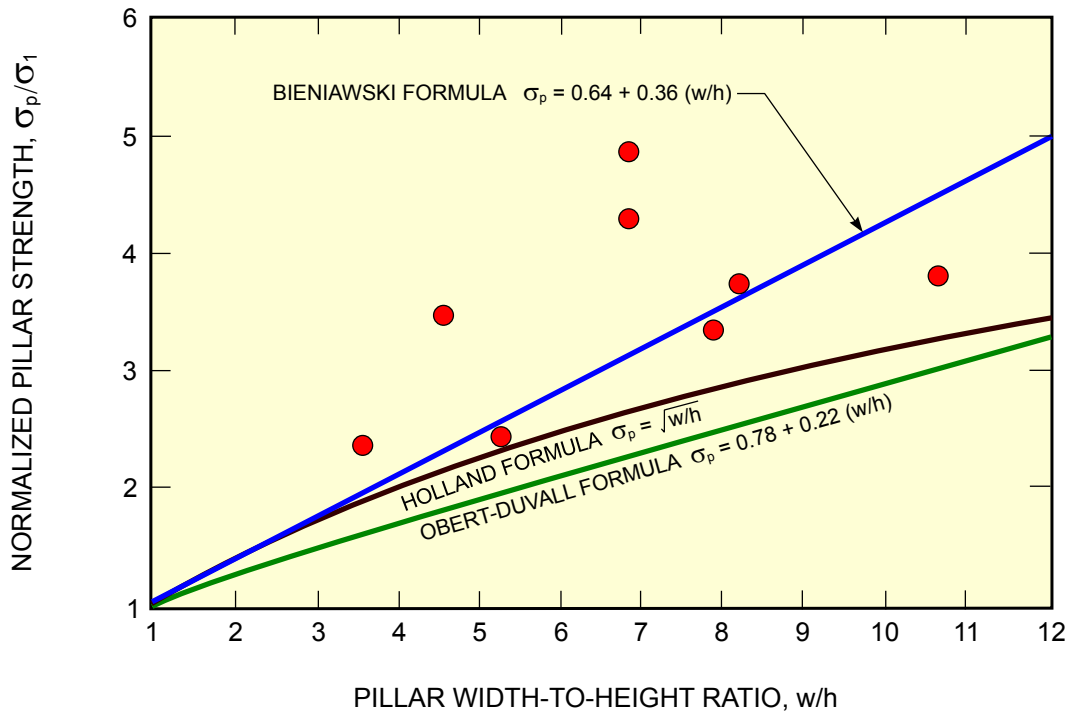
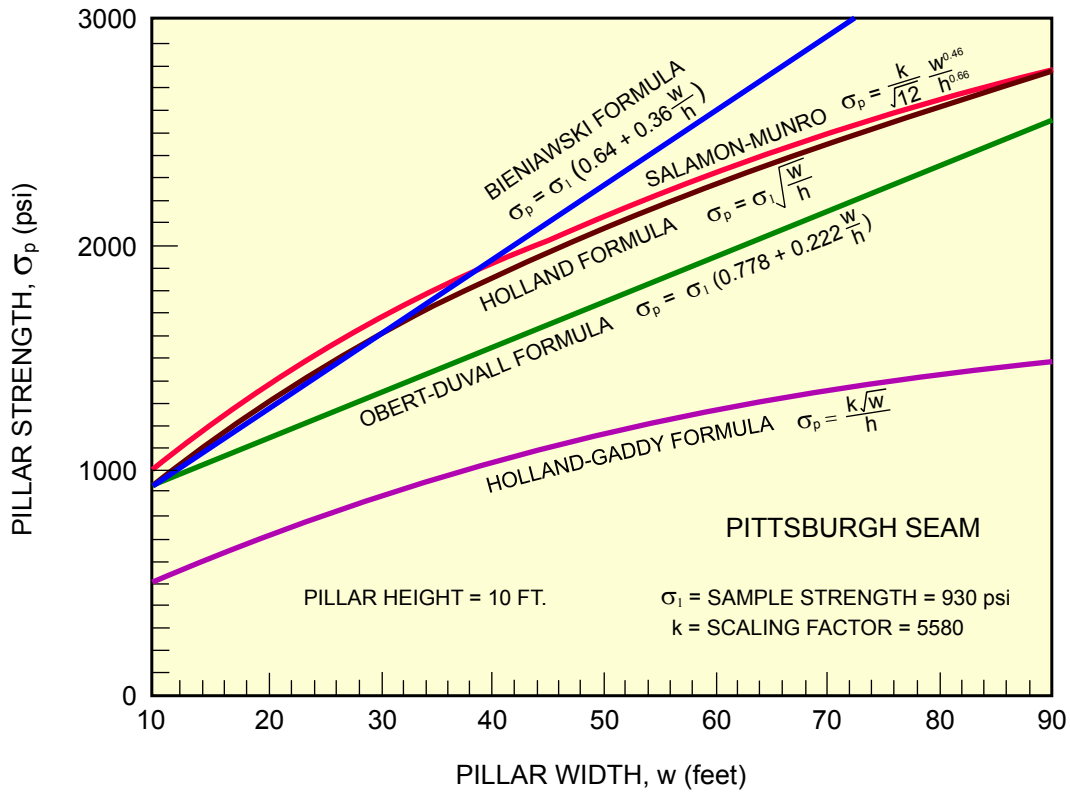

● = Experimental data from actual mine

(BIENIAWSKI, 1987)

FIGURE 8.8 COMPARISON OF PILLAR STRENGTH FORMULAS WITH RESPECT TO WIDTH-TO-HEIGHT RATIO

ity factor, which varies depending on the empirical formula used (Bieniawski, 1992). Mark (2006), in addressing the stability factor for the Mark-Bieniawski Formula, recommends a stability factor of 1.5 for pillars with under 750 feet of cover and 0.9 for pillars with over 1,250 feet of cover. As previously noted, the term “stability factor” should not be confused with “safety factor.” While some long-term pillar stability can be tolerated in certain mining situations, impoundment designers should consider a higher margin of safety for overburden support and control of detrimental differential movement within the dam and foundation.

While the occurrence of subsidence over mine workings in some areas is a function of time, the general assumption for pillar analyses is that coal does not deteriorate over time. The reason is that coal is highly jointed due to cleating, and additional cracking of the coal does not reduce the confinement of the roof and floor, nor does it markedly reduce the coal’s mass strength. Initial pillar designs typically take into account spalling for coal seams susceptible to spalling. This is done by reducing the effective dimensions of the pillars by the anticipated spalled width and widening the opening width by this spalled dimension. Oxidation of the coal can occur for seams above drainage, but this effect tends to be limited to the yielded outer portions of the pillar. Once pumping and ventilation is discontinued, mines below drainage will flood, thus mitigating further deterioration of the coal.

The weathering of soft (high-clay-content) partings (non-coal layers in the pillars) reduces pillar strength over the long term, although the impact appears minor and may not occur after the mine is flooded (Biswas et al., 1995). Biswas et al. (1999) presented an approach for estimating time-dependent deterioration of partings, as well as coal. The authors indicated that much work remains before time effects on coal pillar strength are fully understood.

Computer programs for pillar stability analysis include the ARMPS and LAMODEL models. These programs can be used to evaluate stress distribution and factor of safety. Analyses can be performed considering the pillar sizes and arrangement within the mine, recognizing that some smaller pillars may shed load to larger pillars.

In addition to pillar stability, floor stability is also related to subsidence potential. Bearing capacity analyses have been applied to evaluation of pillar punching into soft floor materials, using the following formulas (Bieniawski, 1992; Brady and Brown, 2004):

For long ($L/B > 10$) pillars:

$$Q_u = 0.5 (\gamma B N_1) + (c N_c) \quad (8-2)$$

For pillars with $L/B < 10$:

$$Q_u = 0.5 (\gamma B N_1 S_1) + (c \cot \phi N_q S_q - c \cot \phi) \quad (8-3)$$

where:

$$\begin{aligned} N_c &= (N_q - 1) \cot \phi \\ N_1 &= 1.5 (N_q + 1) \tan \phi \\ N_q &= \exp [\pi \tan \phi] [\tan^2 (\pi/4 + \phi/2)] \\ S_1 &= 1.0 - 0.4 (B/L) \text{ (dimensionless shape factor)} \\ S_q &= 1.0 - \sin \phi (B/L) \text{ (dimensionless shape factor)} \\ \gamma &= \text{density of floor strata (pcf)} \end{aligned}$$

- B = width of pillar (ft)
- L = length of pillar (ft)
- c = cohesion of the floor strata (psf)
- ϕ = friction angle of the floor strata (degrees)

Bowles (1996) presents several other bearing capacity equations that are applicable to conditions/situations not reflected in the above equations, including: (1) evaluation of strength parameters for rock for use in bearing capacity analysis, (2) the presence of adjacent pillars, (3) the presence of layered foundations, and (4) the effects of horizontal movement of very soft materials below the pillars. Equations developed by Terzaghi, Vesic, and others include parameters to account for these situations. Bowles (1996) presents bearing capacity factors for rock that are recommended for use in the Terzaghi equation. Bowles also presents bearing capacity failure modes for evaluating heave considering the effect of adjacent pillars (using an excavation trench model) for layered strata and for the case when the opening widths are less than 0.7 times the pillar width. Bieniawski (1987) presents equations based on the work of Vesic for analyzing multilayered conditions. Vesic's equation is commonly used for the Illinois Basin because of work by Y. P. Chugh from Southern Illinois University. Similar to pillar partings, floors of mines that are high in clay content tend to deteriorate over time, but this effect is limited to the unconfined floor in openings and near pillar edges (Chugh et al., 1987).

The strength parameters (c and ϕ) of the mine floor strata can be affected by moisture. Just as the evaluation of pillar strength should reflect pillar performance at local mines, available records of floor performance should be reviewed when selecting strength data for analysis. For evaluating pillar punching potential, Bieniawski (1992) recommends a factor of safety against bearing capacity failure (q_u/S_p) of 2.0 based upon the assumptions associated with computing the average pillar stress, although there are situations where a lower factor of safety (generally at least 1.5) is acceptable to provide long-term stability.

It is also possible that very soft material can be squeezed from beneath a pillar. This type of foundation failure is appropriately called a squeeze failure and can be analyzed as described in Bowles (1996).

8.4.3.2 Subsidence Evaluation and Analysis

Empirical approaches for subsidence analysis include: (1) the graphical method, (2) profile functions and (3) influence functions. The graphical method involves use of charts or nomographs and is generally applied in only a few geologically-similar regions. The profile functions approach involves the derivation of mathematical functions that describe the profile of the subsidence trough at the surface based on observed data. This method can be applied to geologically dissimilar conditions by modifying the profile constants, but the method is limited to predicting subsidence at specific points. The use of influence functions involves application of the principal of superposition to evaluate surface subsidence at any point influenced by the underground mine, based upon measured profile data. This method is based upon the assumption of homogeneous, isotropic overburden material, but it has been found to be suitable for subsidence prediction over underground workings with irregular or complex geometries. Singh (1992) provides selected profile and influence functions and examples. Continuum mechanics utilizing various elastic-plastic models has also been employed to analyze subsidence, although the complexity involved in depicting overburden response to mining has limited its application.

Computer programs such as SDPS and CISPM can be used for evaluation of stress at mine areas with varying overburden conditions, pillar and barrier arrangements, and subsidence parameters (settlement, horizontal displacement, curvature and tilt). Based on empirical or site-specific regional parameters, SDPS calculates the ground deformation indices using both the profile function method and the influence function method. The profile function method requires the following minimum input:

panel width, overburden depth, seam thickness, and percent of hard rock within the overburden. The influence function method requires that the mine plan and measured subsidence survey information applicable to the area be input, although average parameters applicable for eastern U.S. coal fields can be selected. The results can be plotted in relation to mine or surface structure geometry.

Procedures for the evaluation of subsidence at coal refuse impoundments overlying mine workings were discussed by Newman (2003) and Karmis and Agiotantis (2004) and include the following steps:

- Digitizing the mine layout plan and ground surface topography.
- Inputting the mine layout plan and topography into software such as SDPS.
- Evaluation of the geologic and overburden properties for classifying and establishing the dimensions of hard rock strata.
- Calibration of the model using regional parameters (e.g., influence angle, strain coefficient, edge effect).
- Establishment of extraction characteristics and the mining height of each panel.
- Adjustment of the extraction geometries based on mine characteristics.
- Calculation of the pertinent deformation indices.
- Contouring and superposition of the results on mine and topographic maps.
- Evaluation of the results.

8.4.3.3 Subsidence Damage Criteria

The strain criteria presented in [Table 8.5](#) have been used in assessing the potential for subsidence impacts on earthen embankment dams and water bodies at the ground surface. Subsidence settlement can affect drainage features and freeboard, as well as impounding structure stability, thus site-specific subsidence parameters need to be established. Impacts on the internal integrity of structures are not clearly related to any specific magnitude of subsidence, but rather to differential movements. For undermined impoundments, the National Coal Board (1975), Babcock and Hooker (1977), and Whittaker and Reddish (1989) have published guidelines based on case studies for limiting surface tensile strain in the overburden to a range of 0.5 to 1.5 percent with the objective of minimizing the inundation hazard to mines. These guidelines, which are empirical, are based upon data from reportedly successful mine operations beneath bodies of water. When sufficient engineering data and mining experience are available, these conservative guidelines should be updated based upon the new data. While strain levels are a rational basis for assessing structural impacts, the difficulty in accurate prediction and measurement of strains suggests that prudence is warranted with respect to establishing tolerable strain and assessing safety zone offsets based on a strain criterion.

Additionally, a refuse embankment or impounding structure may also be subject to damage and failure due to surface tensile strain. Tensile strain has been reported as a gauge of impending cracking in earth embankments by Sherard (1973), who reported that initial embankment cracks generally occur in the range of 0.1 and 0.3 percent tensile strain, as discussed in [Section 6.6.3.1](#). A study of the effects of subsidence on spoil heaps in England found that cracking occurred where observed tensile ground strains exceeded 0.3 percent (Forrester and Whitaker, 1976). Cracking can endanger a dam by reducing the strength of an embankment slope and by creating paths for seepage and material movement resulting in internal erosion. This criterion (as opposed to loss of strength) is particularly relevant to embankment features that control seepage such as liners and cohesive soil cores.

Other structures that may be part of refuse embankments include conduits and pipes, which may be sensitive to low levels of strain depending on their constituent materials and the direction of straining relative to their orientation. Peng and Luo (1993) report that the critical tensile strain for strain-

sensitive structures is approximately 0.2 percent, which is the same as the strain associated with the appearance of visible cracks in masonry walls.

Nieto (1979) published a case history for central Illinois illustrating an evaluation of underground mining and subsidence at a depth of 620 feet. The study involved assessment of the potential for damage to an earth dam associated with adoption of a limiting tension strain of 0.25 percent, consistent with the references cited above and in [Section 6.6.3.1](#).

8.4.4 Mine Breakthrough Potential and Analysis

In this section, mine breakthrough potential and analysis are discussed for: (1) a coal seam with mine workings outcropping into the impoundment area (outcrop barriers) and (2) a coal seam with mine workings extending beneath all or a portion of the impoundment pool (overburden barriers).

8.4.4.1 Outcrop Barriers

Outcrop barriers between mine workings and an impoundment, where the coal seam outcrops into the impoundment, may include:

- Natural soil, coal, and rock overburden between the mine workings and the ground surface
- Coal barriers separating auger holes and house-coal adits from underground mine workings
- Bulkheads and seals consisting of shot rock, aggregate, coarse refuse, grout and/or concrete used to backfill “punch-outs,” auger holes, portals, ventilation boreholes, and rock dust or utility boreholes.

The primary modes of outcrop barrier failure include: (1) uplift failure, (2) shear plug failure, and (3) fractures initiated through discontinuities or subsidence that become enlarged as a result of seepage and internal erosion. Uplift failure occurs when buoyant forces reduce the overburden weight to the point where the differential pressure on the outcrop barrier causes failure. It can be analyzed separately or in conjunction with shear plug failure. Shear plug failure analysis is generally applied to outcrop barriers along coal-floor and coal-roof planes, assuming that the overburden is completely saturated. Because of uncertainties about the limits of mine workings, as well as overburden material properties, conservative assumptions are generally adopted. [Figure 8.9](#) illustrates a sliding wedge analysis at an outcrop barrier and the associated free body diagram for computation of forces using the approach proposed by Newman (2003). Following this approach, which considers only the resistance along the coal-floor surface, calculation of the factor of safety FS for a unit width along the sliding wedge can be determined from:

$$FS = \frac{[F_{slurry} + F_{rock} + F_{coal}] \tan \phi}{F_{water} + F_{K_0}} \quad (8-4)$$

where:

$$F_{slurry} = \left[(w h_{slurry}) - \frac{w^2}{2S} \right] (\gamma_{slurry} - \gamma_w)$$

$$F_{rock} = \left[\frac{w^2}{2S} \right] (\gamma_{rock} - \gamma_w)$$

$$F_{coal} = [w h_{seam}] (\gamma_{coal} - \gamma_w)$$

$$F_{water} = h_w h_{seam} \gamma_w$$

and:

F_{slurry} = effective weight of slurry (lb/ft)

F_{rock} = effective weight of overburden rock (lb/ft)

F_{coal} = effective weight of coal (lb/ft)

F_{water} = effective force of water (lb/ft)

F_{K_o} = lateral force on barrier from overburden (lb/ft)

h_w = net hydrostatic head on coal seam (ft)

h_{seam} = coal seam height (ft)

γ_w = unit weight of water (pcf)

γ_{slurry} = unit weight of slurry (pcf)

γ_{rock} = unit weight of overburden rock (pcf)

γ_{coal} = unit weight of coal (pcf)

ϕ = shear strength for barrier contact (degrees)

w = outcrop barrier width (ft)

S = ground slope at outcrop (dimensionless)

The effective lateral force on the barrier from overburden F_{K_o} is given by the following relationship, based on the properties of the slurry and conservatively treating the soil/weathered coal as slurry:

$$F_{K_o} = [(\gamma_{slurry} - \gamma_w) h_{slurry} h_{seam}] (1 - \sin \phi_{slurry}) \quad (8-5)$$

where:

h_{slurry} = depth of slurry to barrier (ft)

h_{seam} = coal seam height (ft)

ϕ_{slurry} = shear strength of slurry (degrees)

The preceding equations can be modified to include resistance along the roof-coal interface and to incorporate protective embankments at the outcrop. In applying the analysis, the weight of overburden rock and coal may be taken as the total weight only if the mine workings are not and will not be flooded. The effective (or buoyant) weight is applicable if the coal and overburden are affected by seepage and the mine workings are flooded. Conservative assumptions associated with this analysis include:

- Hydrostatic impoundment head is assumed to be acting at the barrier.
- There is no cohesion along the coal-floor interface, and the resistance along the roof-coal interface is ignored consistent with [Figure 8.9](#).
- Three-dimensional effects are not considered (side resistance of the wedge of coal should generally be ignored because of the potential for discontinuities).

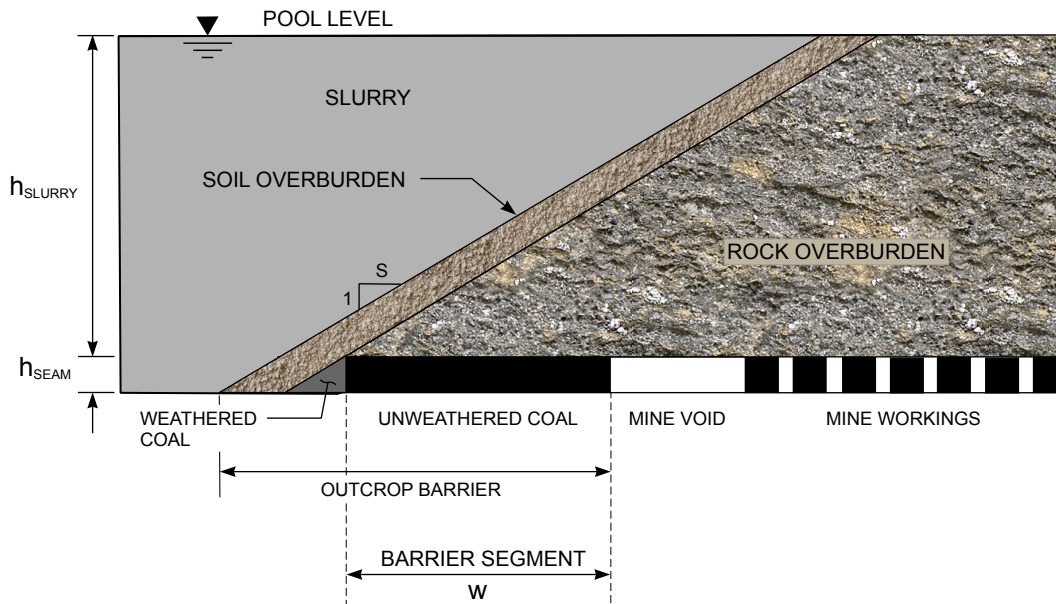

8.9a ILLUSTRATION OF OUTCROP BARRIER

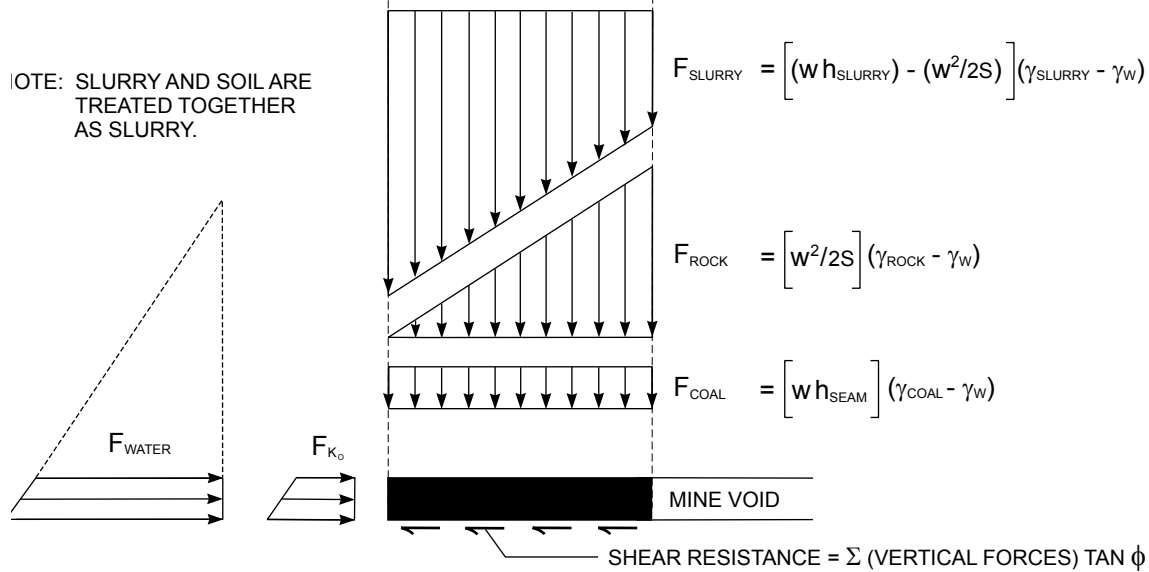

8.9b SIMPLIFIED FREE-BODY DIAGRAM OF EFFECTIVE BARRIER SEGMENT

(ADAPTED FROM NEWMAN, 2003)

FIGURE 8.9 OUTCROP BARRIER BREAKTHROUGH ANALYSIS FOR SHEAR FAILURE

Selection of the barrier width w requires a thorough evaluation of mine maps and exploration information to identify the representative minimum dimension, based on the following:

- Extent of weathering of the outcrop, which can best be evaluated by exploration and sampling.
- Potential for spalling and deterioration of the barrier rib within the mine workings, which can best be judged based on pillar performance within the mine. Biswas et al. (1999) introduce a method for estimation of the decline of pillar strength with time.

- Discontinuities in coal seam or overburden (e.g., stress relief fractures to surface) that may allow hydrostatic pressures to reach the interior of the barrier, the potential for which can be evaluated based on local geologic studies and surficial reconnaissance above the outcrop.

The preceding analysis is based on the assumption of a horizontal outcrop barrier. Adjustments to account for the dip of the coal seam and barrier may be warranted as well as evaluation of possible wedge failure across overburden bedding planes where fracture systems with such orientation are present.

If a man-made barrier instead of coal is being evaluated, the preceding analyses should be performed using the properties of the barrier. The following guidance is provided:

- Earthen materials and aggregate barriers – The strength properties of earthen materials or aggregate should be established based upon how the material was placed to form the barrier and accounting for resistance at the barrier-floor interface only (i.e., resistance between the barrier and the coal seam or roof is ignored).
- Concrete, concrete block, and grouted aggregate barriers – Construction details associated with the barrier keys should be included in the analysis of resistance to failure, along with the interface friction between the barrier and floor/roof, as subsequently discussed in [Section 8.5](#).

Fractures in overburden above an outcrop may have the potential for seepage and internal erosion that could propagate to an impoundment and lead to breakthrough. Natural stress relief fractures, if close to mine workings or subsidence cracks can lead to the potential for breakthrough from internal erosion. Breakthrough potential for this mode of failure can be determined by evaluating: (1) the presence of or potential for fractures and their influence on mine stability, (2) the occurrence and magnitude of subsidence strains and deformations, and (3) the type and effectiveness of any mitigation measures employed. Mitigation measures may include features to control susceptibility to internal erosion such as self-healing granular soils within the overburden and design of fills and filters to prevent piping.

8.4.4.2 Overburden Barriers

When mine workings extend below drainage and beneath the bottom of an impoundment, attention should be focused on the overburden, roof, pillar, and floor stability, as illustrated in [Figure 8.10](#). The potential for breakthrough could be associated with the following scenarios:

- Sinkhole subsidence under relatively thin overburden strata where a roof fall propagates into the overburden and eventually daylight into the impoundment.
- Fracturing of the overburden due to pillar collapse or floor failure, leading to internal erosion propagating to the impoundment.

Analysis of roof stability and sinkhole development is addressed in [Section 8.4.2](#). The potential for these phenomena can be determined empirically using the Rock Mass Rating (RMR) (Bieniawski, 1992) or the Coal Mine Roof Rating (CMRR) (Molinda et al., 2001) and analytically by calculating beam or arch safety factors for each stratum. The analysis of pillar and floor stability, which was addressed in [Section 8.4.3](#), is based on the stability factors of pillars that may lie within a reasonable angle of draw around the periphery of the impoundment, considering room and pillar dimensions, mining height, overburden, and coal strength. Newman (2003) presents an analysis methodology and associated case history for evaluation of breakthrough potential for an overburden barrier.

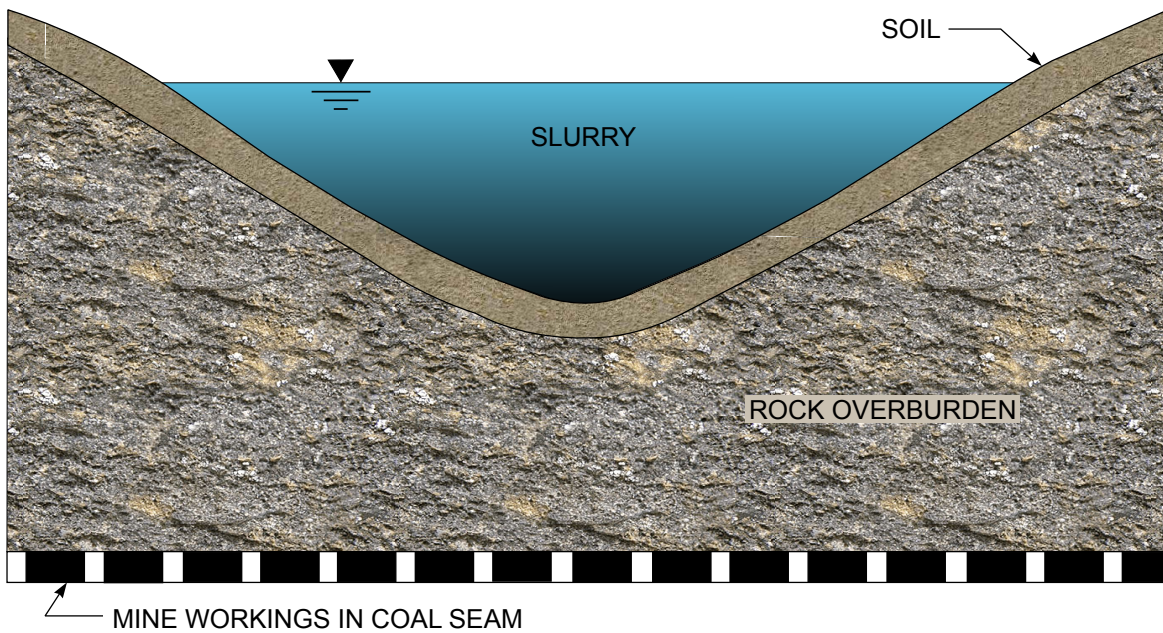

8.10a ILLUSTRATION OF OVERBURDEN BARRIER

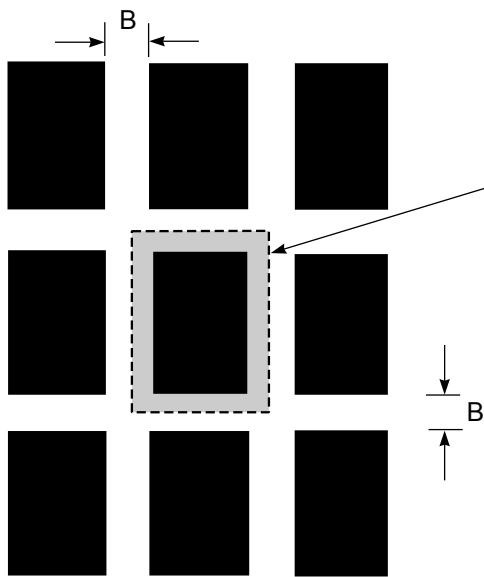

8.10b SCHEMATIC PLAN OF PILLARS

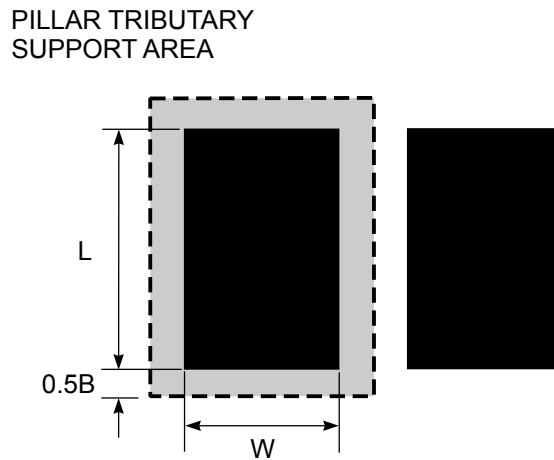

8.10c TYPICAL PILLAR DETAIL

FIGURE 8.10 ILLUSTRATION OF OVERBURDEN BARRIER

8.5 SUBSIDENCE AND BREAKTHROUGH MITIGATION METHODS

Mitigation measures to address the potential impacts of subsidence or breakthrough may include some combination of:

- Providing a safety zone around the embankment and impoundment, limiting mining to only entry development beneath the dam.
- Providing support by backfilling portions of the mine.

- Improving the in-situ materials by grouting.
- Constructing an engineered barrier.
- Isolating the structure from the area of influence of the mining or altering the mining sequence or plan.
- Constructing secondary defense measures such as bulkheads to contain a breakthrough within the mine.
- Other engineered measures or impoundment operating procedures to control seepage and reduce pressures in the areas of potential breakthrough.

Subsidence mitigation measures are dependent on the structure that must be protected. Mine workings beneath a dam must be stabilized such that support for the impounding embankment and abutments is achieved. Overburden or outcrop barriers beneath an impoundment must be sufficient to prevent breakthrough. Mitigation measures for breakthroughs are discussed in MSHA (2003) and NRC (2002) and are summarized in the following sections, which describe potential mitigation alternatives and methods for the design of bulkheads to seal mine entries.

8.5.1 Mine Subsidence and Breakthrough Mitigation

8.5.1.1 Use of Safety Zones

For new impoundments, the most effective method for preventing damage to the dam or a breakthrough is to leave an unmined safety zone between the mine workings and the impoundment so that any mining-induced ground disturbance cannot cause a breakthrough or other significant adverse effects. At new facilities, siting of the impoundment at locations that are not or will not be undermined is preferred. If mine workings cannot be avoided, other mitigation measures may be feasible provided that support for the impounding embankment and appurtenant structures is achieved.

For existing impoundments where the mine workings are already close enough to potentially cause a problem, a safety zone can be created (if necessary) by backfilling the mine workings. Guidelines for sizing safety zones around impoundments are provided in Babcock and Hooker (1977). [Figure 8.6](#) provides an illustration of these guidelines. Kendorski et al. (1979) provide criteria for determining when a surface water body represents a hazard to mining. Peng and Luo (1993) provide guidance for establishing safety zones for sensitive structures.

8.5.1.2 Mine Backfilling

If the thickness and natural characteristics of the overburden barrier cannot be relied on to prevent a sinkhole, subsidence cracks, or other subsidence-related failure mechanisms, filling previously-mined areas with grout or other material (commonly referred to as “stowing”) may be a necessary remedy. The lateral extent of backfilling must include critical areas within the angle of draw based on the results of subsidence analyses described in [Section 8.4.2](#).

The mine backfill material can have minimal strength, and even a partial backfill will offer confinement to mine pillars, thereby reducing spalling and dramatically increasing pillar strength. However, it is good practice to backfill to the roof of the mine, using material with sufficient strength (typically above 100 psi) to reduce consolidation and prevent erosion. This can be difficult to accomplish, as full contact with the mine roof is often not possible because of roof irregularity and the rolling nature of coal seams. However, partial roof contact will reduce roof falls and will dramatically limit roof fall propagation into the overburden.

Pozzolan slurry makes a good backfill, because it readily flows into irregular spaces. Because of the high sulfate environment in a coal mine, any fill containing cement should employ sulfate-resistant

cement, preferably Type V, but in some mine environments Type II cement will suffice. Depending on cement availability, Type II or Type I cement in combination with pozzolans (e.g., fly ash, slag cement) may be required in order to provide adequate sulfate resistance. The extent of the backfilled areas must be sufficient to support the overburden and/or hillside that could potentially be inundated by the impoundment and to protect existing or planned embankment dams and mine seepage barriers from adverse subsidence effects. Boreholes should be advanced to determine if the backfilling program has achieved performance criteria. These boreholes can also be used to locate remaining voids, to perform secondary grouting, and to obtain samples from within the backfilled mine workings for strength testing.

To verify that the backfill strength and coverage is adequate, subsidence and/or pillar analyses should be conducted as part of the mine backfilling design. As a minimum, the following should be specified as part of the backfill design:

- Strength of the backfill material
- Area to be backfilled
- Methods for verification that the design strength and area of backfilling are acceptable

When used with cement, most types of fly ash improve flowability, increase sulfate resistance, and sometimes increase the compressive strength of backfill grout. Fly ash improves the flowability of grout because the spherical particles act like ball bearings that allow the grout to move more freely and the small particle size promotes better filling of voids. In addition, the pozzolanic properties of most types of fly ash increase compressive strength. Use of fly ash also reduces shrinkage and slows setup time, which is important if grout pumping must be interrupted for a few hours. The properties of fly ash will vary dependent upon the coal source used at the originating power plant. Fly ash properties are generally determined by the power companies that generated it and these properties can often be obtained from them.

Fly ash can pose potential environmental and health risks because it contains trace amounts of toxic metals such as boron, molybdenum, selenium, and arsenic. Portland cement also contains these elements, and they can occur naturally in soil and water. (USEPA, 2000) discusses environmental impact considerations associated with the use of fly ash in mine environments.

8.5.1.3 Stowing of Mine Openings and Associated Barrier Construction

It has been common practice to seal mine entries by stowing them with competent rock or other fill in conjunction with constructing a compacted earth or coarse coal refuse embankment on the outside against the openings. This approach can also be used with auger holes. The openings should be filled far enough back into the mine to prevent adverse subsidence or sinkholes that could extend to the ground surface under the dam or impoundment. Typically, aggregate or other rock materials are pushed or rammed into openings to the extent practical with construction equipment. If possible, stowing should extend into the opening for a distance sufficient to mitigate subsidence. In some applications, including areas beneath a dam or abutment, grouting is performed in order to extend the backfilling of the opening, support the roof, and mitigate seepage. In an impoundment area, when it is impractical or infeasible to mitigate subsidence by stowing, other options can be considered such as: (1) earthen barriers designed to provide protection against potential sinkholes or cracks and (2) overexcavation to remove shallow overburden subject to sinkholes and establish a highwall cut. Monitoring systems for detecting movement and/or hydraulic pressure should be considered.

Earth or coarse coal refuse barriers should be protected by appropriate geotextile or graded filters to prevent piping into the mine, open joints, and stowing material. Drains should be installed as

needed to control the hydrostatic pressure. The system of the stowed and external barrier materials must be designed to have sufficient strength and dimensions to resist shear or punching failure into the mine resulting from hydraulic and earth-load forces. The stowed material must also have sufficient bulk and material gradation to provide adequate seepage resistance and thus prevent failure of the embankment or adjoining strata due to piping or hydraulic fracturing into the mine. Figure 8.11a illustrates a stowed opening protected with geotextile and backfill. The fine-aggregate filter shown in the figure should cover the area where fractures or open joints are present or are likely to be a concern.

If a coarse coal refuse embankment is to be constructed over a coal seam outcrop with workings, the exposed coal seam must be covered and sealed with soil or other inert material to provide a fire barrier and to minimize the potential for spontaneous combustion. If water is draining out of the mine from an opening that is to be covered, a drain to prevent water from building up in the mine may be needed. For these cases, the sealing cover should include a drainage system that will release the mine water and prevent hydrostatic pressures from building up and causing problems with respect to saturation, piping, or structural instability. A discussion of internal drain and filter design is provided in Section 6.6.2. If the mine discharge is acidic, drain materials capable of resisting degradation will be required (Section 11.7), and downstream water collection and treatment could also be required (Section 10.3.3).

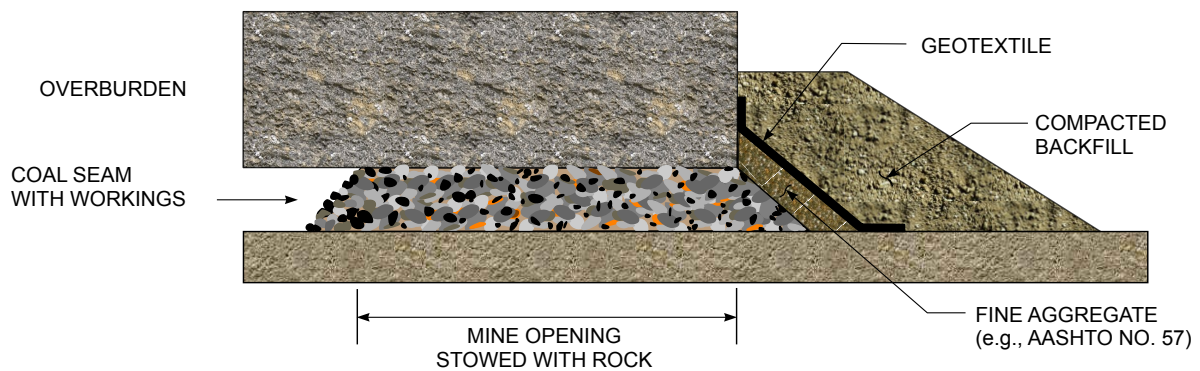

8.11a BACKFILL BARRIER WITH GEOTEXTILE

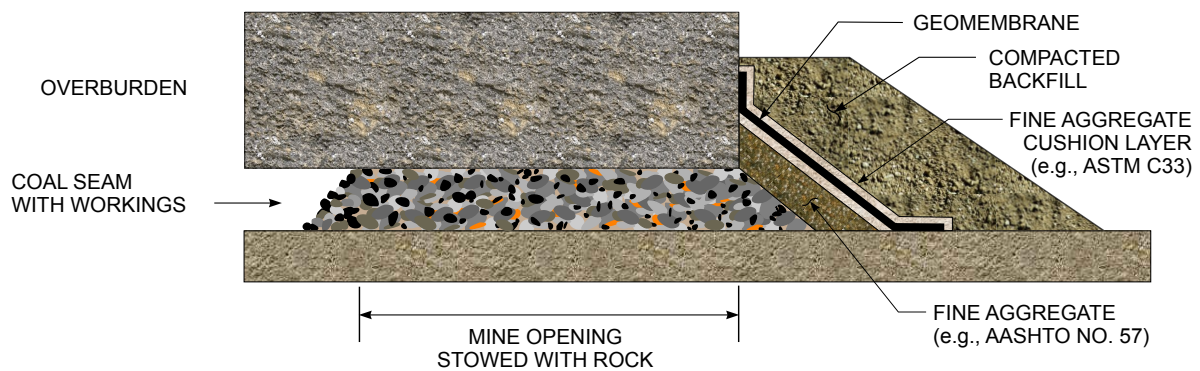

8.11b BACKFILL BARRIER WITH GEOMEMBRANE

FIGURE 8.11 STOWED MINE OPENINGS AND BARRIER CONSTRUCTION

Impervious membranes have been used in conjunction with mine opening seals. A membrane should extend a sufficient distance past the perimeter of an opening to provide an effective barrier encompassing mining-induced fractures and open joints. To prevent seepage from flowing around the membrane, the edges of the membrane should be anchored or embedded. The membrane should be surrounded by a layer of finer-grained, cushioning material to prevent puncture by sharp rocks that may be present in the embankment or highwall. Figure 8.11b illustrates the use of a geomembrane as part of a mine opening seal. Liner systems are discussed Section 10.4.

If mine openings are safely accessible to workers or can be rehabilitated so that they are safely accessible and plans for entry are submitted and approved by MSHA (30 CFR Subchapters G, H I and O), form-work or bulkheads can be constructed to restrict the extent of stowed material to a desired depth into the mine. In this situation, workers could enter the mine to install grout pipes or to do other needed work. This approach has been used successfully for both the pneumatic stowing and grouting of gravel and for installation of a grouted rock plug. Pneumatic stowing and grouting methods are described in the U.S. Bureau of Mines Information Circular 9359 (Walker, 1993). The following considerations apply: (1) some material types or uncontrolled (uncompacted) placement can be subject to erosion under water flow and (2) the operation exposes personnel to dust. These concerns can be overcome by grouting, although the use of cement adds cost, and environmental impacts can be an issue. If the mine opening can not be made safely accessible to workers, rams mounted on heavy construction equipment can be used to pack the stowing material into the opening, but the depth to which the opening can be backfilled is limited.

In addition to stowing the mine opening, measures to isolate the sealed opening from the impoundment and to control hydraulic pressure may also be needed. A compacted embankment fill with an internal drain protected by a filter discharging beyond the limits of the impoundment provides additional protection and redundancy for mitigating breakthrough. Figure 8.12 shows an example of a compacted fill (prior to refuse placement) placed against an outcrop and with a drain wrapped in geotextile and spoil. Drain and filter design requirements are discussed in Section 6.6.2.

8.5.1.4 Bulkhead Construction

Construction of bulkheads inside a mine or at mine portals can be a feature of a breakthrough prevention program. Bulkheads are designed to withstand fluid and/or earth pressures. They may be relatively thin reinforced-concrete structures or relatively thick structures consisting of concrete, grouted rock or polyurethane foam.

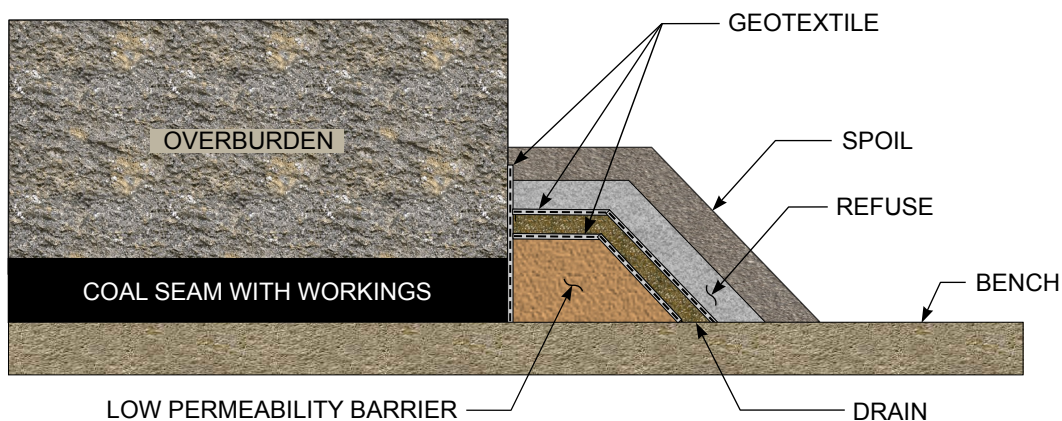

(ADAPTED FROM COWHERD ET AL., 2002)

FIGURE 8.12 BARRIER AGAINST OUTCROP WITH LOW-PERMEABILITY FILL AND DRAIN

In situations where there is uncertainty about the level of breakthrough protection provided by other preventative measures, remote bulkheads can be used as a secondary defense against the discharge of water or slurry through and from a mine. These bulkheads are constructed in mine openings where the water/slurry would flow to (and flow out of) in the event of a breakthrough. For such an application, designers need to consider the rapid build up of air pressure and subsequent impact of water and debris against the secondary structure. Furthermore, the impounding water or slurry in a mine creates the potential for a blowout of an outcrop barrier or bulkhead that should be evaluated. The design of bulkhead seals is presented in [Section 8.5.2](#).

8.5.1.5 Construction of Compacted Earthen Barriers on the Surface

Construction of a compacted earth-fill barrier around the bottom or perimeter of the impoundment area is a design measure that has been used to mitigate potential breakthrough conditions. A compacted earth-fill barrier provides additional bulk between the impoundment and the mine workings and, in combination with properly designed internal drainage, can lower the water pressure against an outcrop barrier. The water pressure can be reduced if internal drains are used to draw down the hydrostatic level in the fill and also to provide an outlet so that seepage discharges in a controlled manner. Compacted earth-fill barriers can be placed and raised as the impoundment level rises. The design of a compacted earth-fill barrier should take into account the potential effect of subsidence, including sinkholes resulting from underlying mine workings. Measures that have been incorporated into barriers to resist potential subsidence movement, cracking and internal erosion include geogrid reinforcement and graded filters.

For designing a compacted earth-fill barrier as a breakthrough prevention measure, one approach is to conduct reconnaissance and excavation of the coal seam in the vicinity of the reservoir that is known or suspected to be constructed over mine voids. The concept is to identify and intercept any mine voids, and thereby expose known or suspected workings near the outcrop. Weathered or fractured strata near the coal seam outcrop should be removed as part of the excavation, thus allowing the barrier to be founded on competent rock. Surface mining of suspect areas is a comprehensive approach for addressing large areas with unknown conditions. The stability of highwalls should also be evaluated, particularly when workings are encountered during construction.

Another approach is to construct the earth-fill barrier over the existing coal seam outcrop without excavation of the seam. The support and internal stability of the earth-fill barrier due to the presence of mine voids should be evaluated. For this approach, there may be exposed highwall if the coal seam has previously been surface-mined, augered or highwall-mined, or there may be an undisturbed outcrop that has not been affected by surface mining.

The construction of compacted earth-fill and coarse coal refuse barriers should be based upon the same concepts regarding material selection and engineering properties, foundation preparation, provisions for internal drainage, slope stability and development of construction specifications used for the design and construction of earth-fill dams and refuse embankments. Where feasible, fine coal refuse slurry should be deposited around these barriers, as the development of a delta of fine coal refuse above the normal pool level will provide additional resistance to breakthrough.

8.5.1.6 Conversion to Slurry Cells

As described in Section 3.4, slurry cells can be used to dispose of fine coal refuse. One approach that can be taken to reduce the breakthrough hazard is to convert from a full slurry impoundment into a slurry cell configuration using compacted coarse refuse to construct small, individual cells or a series of cells over previously placed fines. Some cell designs have reached depths of 12 feet (8 feet of fine refuse covered by 4 feet of compacted coarse refuse). The depth and number of active cells (i.e., cells that are not capped with backfill) at any given time is usually determined by the volume of

storage and cell configuration that will result in a low-hazard potential classification for the facility, as described in [Section 3.4](#). The benefit is that the coarse refuse dikes and covering layers combined with the thin layers of fines allow the fines to dewater and consolidate and make the total mass less flowable. Additionally, with the fines compartmentalized, a problem at one cell location is less likely to affect the entire facility or result in a catastrophic event.

The downstream containment structure (i.e., structural zone) for slurry cells is designed in the same manner as a dam embankment with appropriate width, slopes, benches, internal drainage system, and embankment-material strengths needed to achieve suitable safety factors for slope stability. Slurry cells are most efficient when the depth of fines in the cells is kept relatively shallow, thus promoting drainage from the fines before and during covering.

Some disadvantages of slurry cells include:

- Frequent construction of diversion ditches, new cells, and cell spillways is required as the site elevation increases.
- There is limited flexibility in that a relatively large ratio of coarse refuse to fine refuse is required to keep cell construction ahead of slurry placement, and the fine refuse must settle quickly with limited clarified water retention.
- Close planning and supervision of the site is required so that the construction, filling, and backfilling of cells is accomplished in the proper sequence to make the system function as intended.
- Slurry cell operations are not generally compatible with high production rates at some coal preparation plants.
- Slurry cell operations are not generally compatible with sites that employ conveyor belt/dozer push disposal techniques.
- If a slurry cell site is large enough to be classified as having high-hazard potential, the facility spillways must be designed to handle the runoff from the associated design storm (e.g., PMF).

8.5.1.7 Sealing Sources of Leakage

Discontinuities such as open joints or cracks in a refuse embankment foundation or impoundment area may be treated by grouting or other measures to prevent them from transmitting high hydrostatic pressures and to eliminate potential paths for internal erosion. As a secondary protection measure against leakage, fine coal waste (slurry) can be deposited to form a delta that provides an additional layer of material between the impoundment and potential seepage problem areas. This technique has been used successfully to reduce leakage through embankment and abutment areas and around the perimeter of the impoundment. The long-term benefit of this secondary measure is limited to situations where the bedding planes or joints are relatively small and the sand-sized portion of the slurry is sufficient to allow the gradual formation of a natural filter in joint openings and the eventual sealing of the openings with the clay- and silt-sized particles. If a seepage problem develops after an impoundment is constructed and the technique of distributing the slurry upstream of the seepage area does not correct the problem, then grouting, construction of an impervious barrier, or other measures may need to be taken.

8.5.1.8 Stabilization of Fines

The potential for breakthrough of the contents of a slurry impoundment into underground mine workings can be significantly lessened through stabilization of the fine refuse. Stabilization alternatives include providing drainage measures or treating the fines with additives to increase their strength and/or reduce their water content.

Stabilization of coal-waste fines has sometimes been accomplished by the addition of portland cement or lime-based products. Since the late 1970s and continuing more recently (Fiscor, 2002), studies for development and evaluation of the performance of stabilizer additives have been undertaken. Laboratory studies performed in the late 1970s and early 1980s showed that mixing fine coal refuse with lime-based products may cause the material to appear to have increased strength and stiffness in comparison to untreated material. After samples were mixed and cured, the treated refuse exhibited a relatively stiff load-deformation behavior during initial loading, but then when loading exceeded the apparent maximum past consolidation pressure, the “stabilized” refuse collapsed and the load-deformation characteristics returned to the previous “unstabilized” behavior. In addition, these laboratory studies showed that 5 percent or more by weight of the stabilizers were needed, which made the additives prohibitively expensive except for small treatment volumes. While not all stabilizer additives result in similar behavior, they should always be carefully investigated and used with caution.

Shallow or deep soil mixing methodology using fly ash and cement grout are also methods for stabilizing fine deposits that would be effective for mitigating breakthrough potential. Although not for the purpose of breakthrough mitigation, a portion of a slurry impoundment in Pennsylvania was stabilized in place by shallow and deep mixing with fly ash and cement grout (Bazan-Arias et al., 2002), as also discussed in [Section 6.6.3.3](#). The stabilized fines were then used as the foundation for a highway embankment that crossed the upstream end of the impoundment.

For an existing impoundment, an approach that might be taken is to show that the settled fines have consolidated and gained sufficient strength that they will not flow. Whether settled fines will flow depends on factors such as their degree of consolidation and cohesive strength, pore pressures, the potential for excess pore-water pressures to be induced, and the size of opening associated with a potential breakthrough feature. One qualitative measure of flowability is the moisture content of the fines as compared to their liquid limit (LL) and plastic limit (PL). If the moisture content of fines near the bottom of an impoundment is below the LL and close to the PL, they are less likely to flow and progress to a breakthrough unless the openings in the overburden above or adjacent to the mine are sufficiently large to affect more flowable fines at shallower depths in the impoundment.

A change in conditions in an impoundment, such as inflow of runoff from a large storm, could result in the liquefaction of some portions of the fines leading to an unplanned release of slurry and water through underlying, connected mine workings. Additionally, if subsidence occurs beneath saturated, hydraulically placed fines, the sudden increase in shear stress in the fines may increase pore-water pressure, triggering static liquefaction and causing the fines to flow (Davies et al., 2002). While there may be mitigating conditions in such a situation, measures to drain the fines can be helpful in reducing or eliminating the consequences of a breakthrough because partially saturated fine refuse is likely to densify under load and thus would be more resistant to liquefaction.

8.5.1.9 Overexcavation and Induced Subsidence

Overexcavation of the overburden and mine workings around impoundment perimeters and beneath embankment structural zones may be feasible, particularly in areas of thin overburden such as along outcrops. When applied, this approach includes removal of sufficient overburden to mitigate concern for sinkhole subsidence over the remaining workings by creating a highwall. Barriers must then be designed for any exposed entries found at the base of the highwall. Additionally, highwall stability will need to be addressed as part of the overexcavation plan.

Inducing subsidence through controlled blasting may also be a feasible approach. Guidelines for evaluating the technical and cost feasibility of using controlled blasting to induce subsidence are provided by Workman and Satchwell (1987). In areas where old, unmapped, or poorly mapped mine workings make evaluation of mine breakthrough potential difficult, collapsing the workings by controlled blasting may be an option. Controlled blasting can prevent future mine subsidence

from inducing cracks or sinkholes or from compromising planned mine seepage barriers. However, not all rock overburden strata are suitable for this approach; implementation requires: (1) a geologic investigation for determining the character of the strata, (2) a test area for initial demonstration, and (3) monitoring programs for evaluating performance and addressing safety issues associated with blasting and impacts to adjacent areas. Obviously, this approach should be evaluated with considerable diligence and should only be implemented under the guidance of persons with expertise and experience in dam safety, explosives, and the blasting characteristics of local rock strata.

8.5.1.10 Monitoring Provisions

Whenever there is potential for subsidence to affect a dam or for a breakthrough, critical parameters should be identified and a monitoring program should be implemented to determine whether the dam and overburden is performing/behaving as anticipated. Typical monitoring might include instrumentation for measuring reservoir and piezometric levels, discharge rates from mine workings and drains, seepage quantity and quality, water levels in the mine, ground movement, and weather conditions. Use of such instrumentation is discussed in [Sections 13.2.1](#) and [13.2.2](#). Acceptable ranges and warning or action levels should be established for all monitored values. Monitoring programs should include requirements for plotting and evaluating data in a timely manner and review by an engineer familiar with the design of the facility. Such practice permits detection of trends and correlations to other data.

8.5.2 Mine Entry Bulkhead Seal Design

Bulkheads, also known as hydraulic seals, may be installed across underground mine entries or in mine openings at coal seam outcrops. Normally, bulkheads are installed across underground mine entries to control groundwater in abandoned workings, to prevent rapid inundation of active mine areas in the event of a breakthrough, or to serve as a retention dam in an underground disposal system for fine coal waste. At coal seam outcrops, bulkheads have typically been used to prevent access and to control acid mine drainage. Bulkheads have also been installed at outcrop openings within the footprint of a refuse embankment or within the refuse impoundment to prevent stored water or slurry from flowing into active or inactive underground mine workings. Also, when coal barriers are found to be inadequate, bulkheads may be added on the mine side of the barrier to enhance safety. Design considerations include: site preparation, seal type selection, design load assessment, structural resistance of the bulkhead and surrounding strata, and safety monitoring. Additional guidance is presented in *Guidelines for Permitting, Construction and Monitoring of Retention Bulkheads in Underground Mines* by Harteis, et al. (2008)

8.5.2.1 Site Preparation

As problems with bulkheads are often associated with seepage along the bulkhead and rock interface or through the surrounding strata, the nature of the rock strata at a bulkhead location is important. To the extent practical, bulkheads should be located in the most competent and least fractured area available (normally away from pillar corners), so that problems are minimized. The information gathered as part of the evaluation of a potential bulkhead location should include the type and strength of the rock in the roof and floor and the strength of the coal at the location under consideration. Data related to roof falls, pillar punching, floor heave, or other unusual conditions should be reviewed and evaluated. Coal pillars adjacent to the bulkheads should have a high factor of safety against failure, taking into account all loading factors including transfer stress due to overlying or underlying mining and stresses imposed by the dam and impoundment. Another consideration is that once a bulkhead is constructed, active mining in the vicinity, whether in the same seam or in other seams, can affect the surrounding strata and the load on the bulkhead itself.

As part of the evaluation, fractures or joints in the surrounding rock should be located and characterized. Geophysical techniques can be employed to supplement visual observation for locating rock discontinuities. The potential for subsidence and sinkhole formation over entries should also be

assessed. If joints, fractures, or subsidence cracks are present, then chemical or cement-based grouting measures may be necessary in order to minimize seepage pathways that could lead to piping problems or deterioration of the rock strata. To maintain the integrity of a bulkhead, it may be necessary to construct a grout curtain around the perimeter of the planned location. In addition to grouting, loose, cracked, and weak floor, roof, and rib material should be removed. Regardless of the bulkhead type, if the surrounding material consists of weathered or soft rock, then piping (internal erosion) and hydro-fracturing of this material should be considered as potential failure mechanisms.

In-mine bulkheads have failed because of softening of the floor material. These failures occur with a “rooted” claystone referred to as fireclay. When subjected to water, this material breaks down from a rock-like material to a soft soil. The presence of water causes the electrostatic charge on the component clay particles to break down. This process results in dispersion of the clay particles, loss of cohesive strength, and potential erosion from seeping water. For this reason, claystone and fireclay floors should be removed from beneath the planned footprint of a bulkhead by trenching to a depth sufficient to expose hard, competent rock. Trenching should minimize the potential for a floor failure directly beneath a bulkhead. Floor trenches should be backfilled with a seepage-resistant material such as a cement-based or polyurethane-foam product. The surface of fireclay running under the pillars should be sealed and the bulkhead should be constructed as soon as possible after the floor is exposed in order to limit the tendency for the fireclay to swell or absorb moisture from the air.

Shales in mine roofs, floors, and partings tend to be pyritic and thus prone to swelling. Bulkheads in shale should be designed to accommodate additional load due to swelling and should also accommodate deterioration of the shale over time due to weathering and moisture effects. High-clay-content shales can break down in the same manner as fireclays, and similar measures to those discussed above can be used to mitigate potential problems.

The integrity of a bulkhead system can be affected by hydraulic fracturing. This type of fracturing can occur when pressure from seeping water is sufficiently great to cause cracks in rock strata to widen and grow. When coal is mined to create an entry, the associated stress relief can result in stress fractures or the opening of natural discontinuities in the mine roof, ribs, and floor. Specifically, the floor may heave upward in some mines. This opening of the rock strata can lead to additional hydraulic fracturing if seepage pressures elevate. Strata grouting and notching of bulkheads into competent material are methods for mitigating potential bulkhead damage due to hydraulic fracturing.

Prior to construction, supplemental roof support should be provided near the interior (inby) and exterior (outby) sides of the bulkhead location. Roof support alternatives include roof jacks and cribbing on both sides of the bulkhead. Unlike typical mine supports, these supplemental roof supports are considered permanent installations. Therefore, corrosion protection should be incorporated into all steel supports, and concrete or other durable cribbing material should be used. Soft floor materials should be removed before installing supplemental roof supports. Notching of the bulkhead into the surrounding rock strata is also recommended. A notch will create a longer flow path for seepage and will increase the resistance to a contact failure between the bulkhead and the rock strata. In most cases, notching will place the bulkhead in contact with more competent material as loose material is removed to construct the notch. When roof notching is not feasible, a steel structural-angle member (with corrosion protection) can be bolted to the roof on the outby side of the bulkhead to provide lateral support. Angles with dimensions of 6 inches by 6 inches by ½ inch have been used for this purpose, but the angle should be sized based on the design loads. Seepage resistance can also be increased by treating the surrounding rock strata with a low-hydraulic-conductivity coating such as shotcrete.

8.5.2.2 Bulkhead Types

Several types of materials and physical arrangements have been used for bulkhead construction. [Figures 8.13](#) and [8.14](#) illustrate entry and drift opening bulkhead concepts, including bulkheads

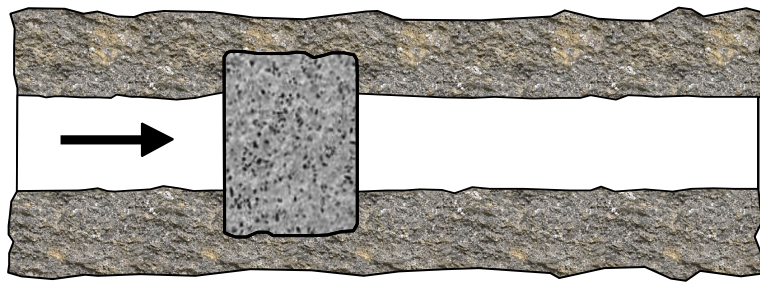

8.13a WALL KEYED INTO RIBS, ROOF AND FLOOR

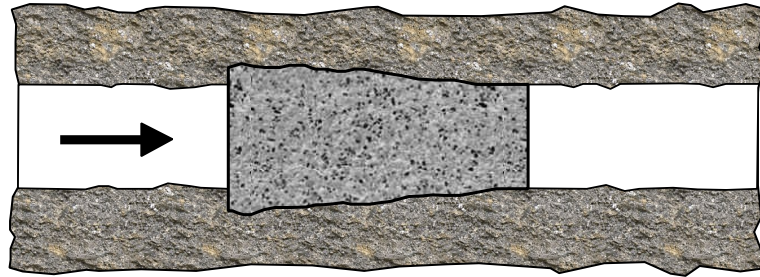

8.13b TAPERED PLUG

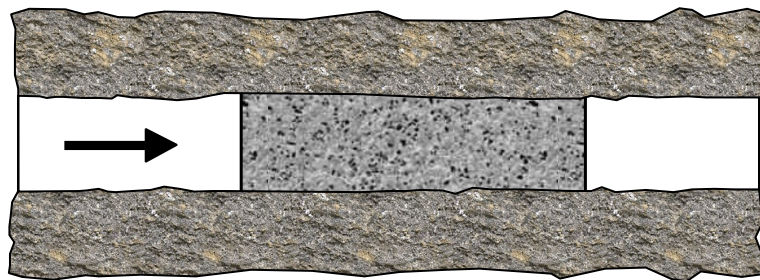

8.13c PARALLEL PLUG

➔ = DIRECTION OF HYDROSTATIC PRESSURE

(HARTEIS AND DOLINAR, 2006)

FIGURE 8.13 BASIC BULKHEAD DESIGN CONCEPTS

installed at mine entrances to prevent water from entering. Bulkhead arrangements typically are either thick plugs with a straight or tapered length or thin walls with a straight or arched shape. Each type of construction has advantages and disadvantages. In general, the thicker the bulkhead, the more resistance there will be to seepage and piping around the perimeter.

Kirkwood and Wu (1995) present technical considerations for mine seals to withstand hydraulic heads in underground mines. Solid concrete block walls can be designed to withstand these loads and have been tested under hydraulic pressure of 40 psi (92 feet of head), but it is recommended that the maximum hydraulic pressure be limited to 2.6 psi (6 feet of head) because of long-term effects of strata movement and deterioration surrounding the seal (Chekan, 1985). Reinforced-concrete walls can be designed for significant hydraulic loads, provided it is recognized that the maximum safe head is controlled by the capacity of the surrounding rock. While notching a seal will help increase the total shearing resistance provided by the surrounding rock and increase the seepage path, the bearing

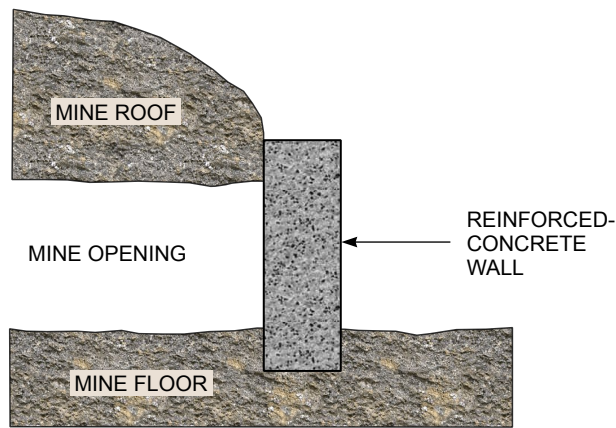

8.14a REINFORCED CONCRETE "CAP" BULKHEAD

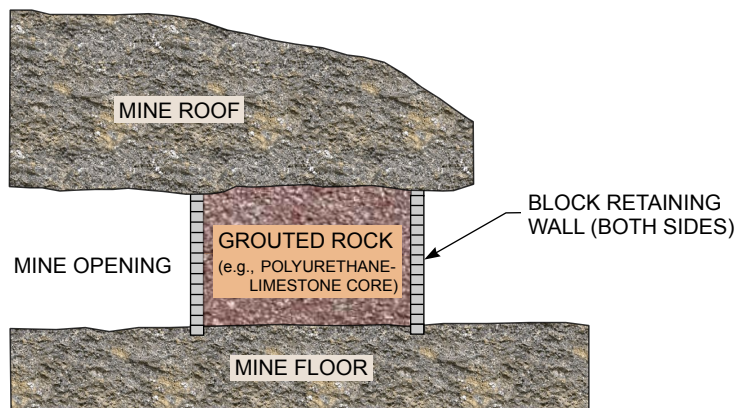

8.14b GROUTED BULKHEAD

(HARTEIS AND DOLINAR, 2006)

FIGURE 8.14 DRIFT OPENING BULKHEAD DESIGN CONCEPTS

capacity of the floor and adjacent ribs must be addressed. The difficulty of achieving adequate contact with the roof and dealing with the limited access for working the concrete around the reinforcing can best be handled by using experienced work crews. When constructed as a drift opening bulkhead, a reinforced-concrete wall (Figure 8.14a) can be used to cap off an entry, but contact with the mine roof may require notching, dowels, or other measures to improve the seal and structural integrity.

Thick concrete-plug seals overcome these limitations through development of thicker barriers with significantly more contact with the mine ribs, floor and roof. Typically concrete-block walls serve as forms at either ends of the seal, and concrete or cement-foam materials are used to construct the plug, as shown in Figure 8.15. Grouted-rock seals are similarly constructed, but include rock (gravel to large hand-placed rock) that is grouted in place, as shown in Figure 8.14b. Grout materials vary from cement to rigid polyurethane foam. Grouted-rock seals are generally as thick as or thicker than concrete-plug seals.

When cement-based products are used to construct thick plugs, consideration should be given to the possibility of heat buildup within the fresh concrete mass during curing (Figure 8.15). This buildup

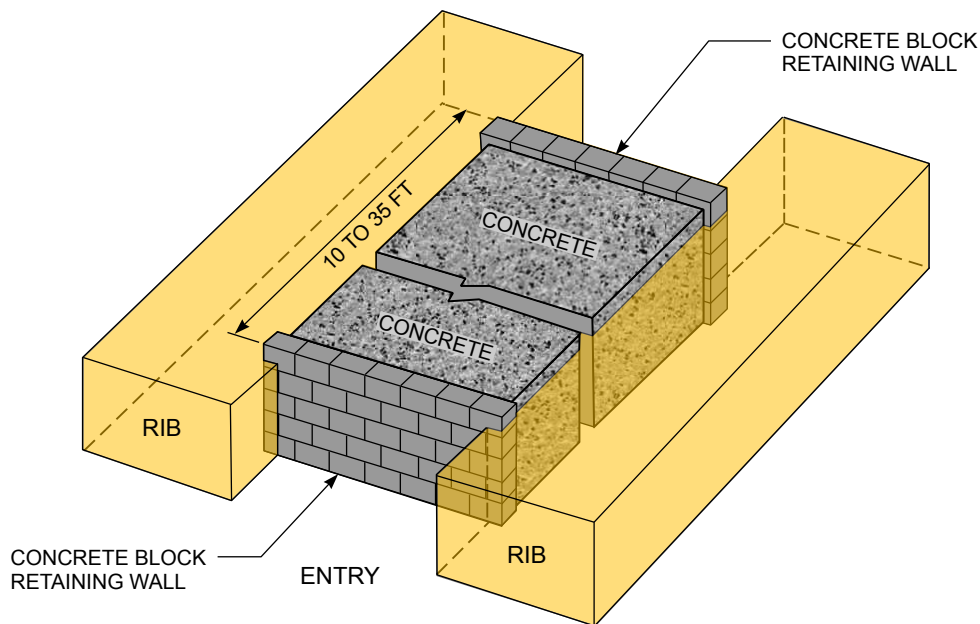

(ADAPTED FROM CHEKAN, 1985)

FIGURE 8.15 BULKHEAD CONFIGURATION SHOWING CONCRETE-BLOCK RETAINING WALLS AND CONCRETE CENTER

of temperature is termed the heat of hydration and, if not accounted for, can lead to internal cracking within the plug and to property changes in the surrounding rock strata during the curing period. Measures to minimize heat buildup include using low-heat cements, replacing a portion of the cement with certain pozzolans, using larger aggregate, and cooling the mix water. Guidance can be found in ACI 207.1, *Guide to Mass Concrete* (ACI, 2005a). Polyurethane foam will also generate heat as it cures. The potential for this heating to cause a fire due to contact with combustible material must be taken into account.

Also, polyurethane foam is highly sensitive to moisture that may be present at a bulkhead construction site. Moisture can cause the foam to expand more than intended, resulting in a lower density and lower strength material. The product manufacturer should be consulted regarding measures to prevent moisture from adversely affecting the foam.

Regardless of type of material selected for bulkhead construction, resistance to deterioration from acid mine water should be evaluated. For example, sulfates in groundwater, coal and the surrounding rock strata can cause deterioration or spalling of certain types of cements that are not inherently resistant to sulfate attack. Because of the high-sulfate environment in a coal mine, any cement used in fill should be sulfate resistant. Type V cement is preferable, but in some mine environments, Type II cement will suffice. Depending on cement availability, Type II or Type I cement in combination with pozzolans (e.g., fly ash, slag cement) may be used in order to provide adequate sulfate resistance.

When formwork is used for bulkhead construction, it should be adequately braced for structural support, and vents should be installed at the top of the formwork to release entrapped air and to prevent the formation of voids. Because concrete can shrink during curing, remaining voids between the surrounding rock strata and the bulkhead should be filled by contact grouting.

In selecting the type of bulkhead, consideration should be given to the potential for roof convergence. Some types of materials (e.g., low-density cementitious foams, lightweight concretes, and polyurethane foams) can accommodate this compression by deforming without cracking.

8.5.2.3 Design Loads

Bulkheads should be designed to resist the estimated maximum hydraulic and geologic loads. The hydraulic pressure is affected by the projected head of water or slurry behind the bulkhead. This level may be influenced by such factors as:

- Other mine drift openings
- Shaft or borehole openings
- Flooded overlying mines
- Flooded adjacent mines with inadequate barrier pillars
- Partial height seals located up-dip that act as a weir spillway and divert the water elsewhere in the mine
- Changes in the mine floor slope that divert water into other parts of the mine
- Maximum seasonal groundwater levels or effects of slurry injection
- Maximum design storm water level in an overlying impoundment

The potential water level in overlying flooded mines is a concern if cracks in the interburden provide a hydraulic pathway between mines. There have also been instances where flooded mines located beneath the subject seam dip such that the flood water heads in the seam below are greater than the elevation of the bulkhead in the overlying mine opening or entry. In this case, if cracks are present in the interburden strata, the water level in the underlying mine could control the bulkhead design head. The inlet elevation of drainage pipes extending through up-dip ventilation seals is normally not considered the limiting design water pool level because these pipes can clog. Because of these considerations, an accurate, up-to-date contoured mine map is essential for predicting the design pool level.

In addition to static hydraulic loads, seismic loads may need to be considered if a site is located in a seismically active area. In this event, bulkhead design should account for both the inertial and the hydrodynamic forces that could result from an earthquake. The hydrodynamic forces would result from an increase in static pressure caused by acceleration of the water mass behind the bulkhead.

The roof in a mine entry can exert a compressive load on the top of a bulkhead seal. This compressive force should be determined based on experience with convergence or by estimating the stress that could occur in the zone of material forming the pressure arch over the entry.

A bulkhead should be designed to have the structural capacity to resist the forces acting on it with a factor of safety consistent with the degree of uncertainty associated with the type and magnitude of load and the consequences of failure. A bulkhead must be able to resist the shear and bending stresses caused by the pressures acting on its face. The bending stresses between the roof and floor and between the adjacent ribs can be calculated based on the width and length dimensions and the type of edge restraint (Timoshenko and Woinowsky-Krieger, 1959; Young and Budynas, 2001). For bulkheads that are thick relative to their span, Young and Budynas (2001) provide guidance on stress multipliers. In addition to resisting lateral loads, the bulkhead should have the capacity to resist vertical bearing loads caused by the mine roof convergence and stress transfer. With relatively thin bulkheads, grouting may be necessary in order to prevent excessive seepage from adversely affecting the anchorage of the bulkhead or the surrounding strata.

8.5.2.4 Design of Solid Concrete Block Bulkheads

The analysis of a solid concrete block bulkhead requires estimation of the shear strength around the perimeter of the wall and evaluation of the structural capacity of the wall itself. The structural capac-

ity of the wall is dependent on the bending stresses near the center of the entry. Because a concrete block wall has no steel reinforcement, it has relatively poor flexural strength, and, except in the case of very narrow entry widths, the lack of flexural strength limits the maximum hydraulic head more than the strength of the surrounding strata. Kendorski et al. (1979) provide guidance for block wall design and the estimation of flexural stress. The structural capacity of the concrete block wall will also depend on the strength of the block, the strength of the mortar, joint thickness, and the quality of construction. Masonry design and construction guidance such as ACI 530, *Building Code Requirements for Masonry Structures* (ACI, 2008), should be followed.

8.5.2.5 Design of Concrete Bulkheads

For thin bulkheads installed with an entry width-to-height ratio greater than 2, a reinforced-concrete bulkhead can be designed as a one-way slab spanning between the roof and the floor if adequate edge connections are provided at the mine roof and floor. To account for temperature and shrinkage stresses, reinforcement is required in the rib-to-rib direction if the bulkhead is designed for one-way behavior in the roof-to-floor direction. For an entry width-to-height ratio less than 2, the bulkhead can be designed for two-way behavior provided there is adequate anchorage on all four sides. However, reinforcement should be sized to separately carry the full bending moment if there is concern that either the roof or floor or ribs may not provide adequate resistance. Regardless of the width-to-height ratio, diagonal reinforcement steel should be placed in the bulkhead corners to control cracking from torsional moments. Regardless of the load path direction assumed, if the mine roof, floor, and ribs are notched into the surrounding rock strata or if the steel bar reinforcing mats near the inby and outby faces are doweled into the surrounding strata, then it is possible to develop negative moment bending stresses at the edges of the bulkhead slab. Negative steel (i.e., the reinforcement near the inby “wet side” face) should be sized to resist negative moment bending stresses.

Reinforced-concrete structures should be designed in accordance with the most recent version of ACI 318, *Building Code Requirements for Structural Concrete* (ACI, 2005b) and ACI 350 (where applicable). The codes are based on ultimate strength design in which factors are applied to the loads and strength to account for the uncertainty of these parameters in structural design. Using this approach, a safe design is achieved when the factored design strength of a structure component exceeds the factored loads. For fluid pressure loading, the load factor is 1.4 when the maximum height of the water or slurry is controllable or conservatively estimated. Thick concrete bulkheads with a thickness-to-height ratio greater than 1 should be designed in accordance with [Section 8.5.2.5.2](#).

8.5.2.5.1 Design of Reinforced-Concrete Bulkheads for Flexure

Where the span-to-thickness ratio of the bulkhead is greater than 2, the design flexural strength of a reinforced-concrete member (ACI, 2005b) is determined using the relationship:

$$M_d = \Phi A_s f_y \left[d - \frac{a}{2} \right] \quad (8-6)$$

where:

$$a = \frac{A_s f_y}{0.85 f'_c b} \quad (8-7)$$

M_d = flexural design strength (lb-in)

Φ = strength reduction factor = 0.90 (dimensionless)

A_s = area of tension reinforcement (in²/ft)

f_y = yield strength of reinforcing steel (psi)

d = distance from extreme compression fiber to centroid of tension reinforcement (in)

- a = depth of rectangular stress block at failure (in)
 f'_c = specified minimum compressive strength of concrete (psi)
 b = width of compression face of member, normally taken as 12 in for slabs (in)

For thick bulkheads with a span-to-thickness ratio less than or equal to two, the flexural design strength from Equation 8-6 should be modified to reflect the behavior of a thick flexural member. Because thicker members have low span to thickness ratios, a linear stress distribution is no longer valid. According to Park and Paulay (1975), for simply supported members with span-to-depth (thickness) ratios less than or equal to two, the internal lever arm can be calculated as:

$$z = 0.2(\ell + 2h) \quad 1 \leq \ell/h \leq 2 \quad (8-8)$$

$$z = 0.6\ell \quad \ell/h \leq 1 \quad (8-9)$$

where:

- ℓ = centerline-to-centerline span distance of two bearing points or 1.15 times the clear span, whichever is smaller (in)
 h = thickness of bulkhead (in)
 z = internal lever arm (in)

Applying the revised lever arm value to the standard flexural equation (Eq. 8-6), the capacity can be estimated using:

$$M_d = \Phi A_s f_y z \quad (8-10)$$

The value of z should not exceed $d - a/2$. If the end supports are assumed to be fixed, rather than simply supported, the value of z should be further adjusted (Park and Paulay, 1975). Nilson et al. (2002) recommend that tension steel in a deep flexural member be distributed over the bottom third of the member depth.

8.5.2.5.2 Design of Unreinforced-Concrete Plug Bulkheads for Shear

Unreinforced-concrete bulkheads typically have a thickness-to-height ratio greater than 1. The shear resistance of these bulkheads may be governed by the:

- Shear strength of the seal material
- Shear strength of the surrounding strata
- Contact interface shear strength between the seal and the strata

In cases where there is no notching of the bulkhead into the surrounding strata, the interface resistance will be governed by adhesion or friction. The South African plug formulas, which are based on the shear strength and bearing capacity of the bulkhead material and surrounding strata, are often used to evaluate the required length of thick bulkheads (Garrett and Campbell Pitt, 1961):

$$\ell = \frac{p a b}{2(a + b) f_s} \quad (8-11)$$

$$\ell = \frac{p a b}{(a + b) f_c} \quad (8-12)$$

where:

- ℓ = length of bulkhead (ft)
- p = hydraulic pressure on bulkhead (psi)
- a = width of entry (ft)
- b = height of entry (ft)
- f_s = minimum allowable shear strength of strata or plug material, whichever is less (psi)
- f_c = minimum allowable compressive strength of strata rock or plug material, whichever is less (psi)

The values of f_s and f_c obtained from sampling may not conservatively reflect the strength of the de-stressed edges of the coal pillars. The designer should select the bulkhead length based on the larger of the values obtained from Equations 8-11 and 8-12. These equations are most applicable to high-head situations where the bulkhead acts as a massive plug. If the bulkhead span-to-thickness ratio is greater than one, then flexural reinforcement should be provided, as discussed in [Section 8.5.2.5.1](#).

Selecting shear strengths for coal is problematic, as such values are typically not determined and research in this area is limited. Coal is generally crushed or yielded at ribs and extending some distance into pillars. Some designers use the cohesive strength of the coal if the ribs are scaled and the bulkhead is constructed before substantial additional yielding takes place. If this is not possible, the residual cohesive strength of coal is taken as its shear strength. A common estimate for the cohesive strength for coal is 145 psi, which, depending on the practitioner asked, may have resulted from the calculation of 16 percent of the typical compressive strength ($0.16 \times 900 \text{ psi} = 144 \text{ psi}$) or from an assumed minimum value of 1 MPa (145 psi). Sixteen percent is a rule-of-thumb sometimes used to estimate the cohesive strength of rock from the compressive strength. It can be difficult to obtain representative samples of coal for testing, but a method of estimating the shear strength of coal is to conduct direct shear tests with coal samples oriented to model in-mine conditions.

Methods for increasing bulkhead resistance include notching the bulkheads into the surrounding rock strata, tapering the plug, and/or installing corrosion resistant, epoxy-coated dowel rods into the surrounding rock strata and allowing the rods to protrude into the bulkhead. The dowel rods should have an embedded length into the surrounding strata and the bulkhead sufficient to develop the strength of the dowel rod without a bond failure. The minimum required development length in concrete should be determined in accordance with the most recent version of ACI 318, Section 12.2.

Thick concrete bulkheads with a thickness-to-height ratio greater than 1 should be designed in accordance with the most recent version of ACI 207.1. Reinforcement should be provided to control temperature and shrinkage stresses at the surface and should be designed in accordance with the most recent version of ACI 318. Reinforcement is not necessary when the bulkhead thickness is greater than 6 feet, provided that steps are taken to control the effects of temperature and shrinkage. Heat of hydration can be controlled by using low-strength concrete, low-heat cement, or replacing a portion of the cement with pozzolans. It can also be controlled by reducing the placement temperature using cooled mix water or aggregates. Accelerating admixtures should not be used.

8.5.2.5.3 Design of Reinforced-Concrete Bulkheads for Shear

While Equations 8-11 and 8-12 can be used to determine the required length of thick bulkhead plugs in order to prevent failure in shear, Equation 8-13 can be used to calculate the design shear strength of concrete for thinner, reinforced-concrete bulkheads:

$$V_c = 2 \Phi \sqrt{f'_c b_w d} \quad (8-13)$$

where:

- V_c = shear strength of the concrete bulkhead per unit width (lbs)
- Φ = shear strength reduction factor = 0.75 (dimensionless)
- b_w = unit width of bulkhead (12 in)
- d = distance from inby side of bulkhead to centroid of tensile reinforcement (in)

If Equation 8-13 indicates inadequate concrete shear strength, a more rigorous formulation should be obtained from the most recent version of ACI 318, Section 11.3. In addition, the contribution of steel shear reinforcement, as discussed in ACI 318, Section 11.5, can be added to the value obtained for the concrete to obtain a combined shear strength for the bulkhead.

For thick, reinforced-concrete bulkheads where the ratio of the clear span distance ℓ_n to the depth d from the inby side of the bulkhead to the centroid of the tensile steel reinforcement is less than four, the most recent version of ACI 318, Section 11.8 should be applied. It should be noted that the span-to-depth ratios are different for shear design than they are for flexural design.

If lightweight concrete with a density of 100 to 110 pcf is used, values of V_c obtained using $\sqrt{f'_c}$ in the Equation 8-13 should be multiplied by 0.75 for "all-lightweight" concrete and by 0.85 for "sand-lightweight" concrete, or should be in accordance with the most recent version of ACI 318, Section 11.2.

8.5.2.6 Monitoring of Bulkheads

The water pressure behind a bulkhead should be monitored so that it can be compared to the design pressure. Warning levels that would warrant drawing down the mine pool or initiating an emergency action plan should be established. To lower the water pressure, a corrosion-resistant pipe should be installed through the bulkhead with a "U-trap" and a pressure relief valve on the downstream end and with provisions to prevent clogging (such as a riser and trash rack) on the upstream end. Pipes extending through a bulkhead should be equipped with external collars to cut off seepage and minimize the potential for a pipe blowout.

A possible safety measure for regulating the maximum hydraulic pressure is to install an additional pipe through the bulkhead with a corrosion-resistant rupture disk attached to the downstream end. If the hydraulic pressure on the bulkhead reaches the rupture strength of the disk, it will fail and thus limit the load on the bulkhead. The outlet end of the pipe should project downward to prevent injuries to anyone near the pipe if the disk should suddenly rupture. If water could collect and flood workings, inhibiting escape for miners, an evaluation of the consequences of an unexpected water release should be conducted.

Seepage can occur through a bulkhead or the surrounding strata, but the presence of seepage is not necessarily a sign of distress. Since unexpected increases in seepage could indicate deterioration of the bulkhead or adjacent strata, seepage through the bulkhead and the surrounding strata along with the corresponding head behind the bulkhead should be monitored and evaluated. To this end, seepage on the active side of the bulkhead is often channelized and monitored using a weir to facilitate measurement of changes in quantity.

A final safety measure is to establish an inspection schedule for long-term monitoring of the bulkhead and to have a contingency evacuation plan in place for situations where problems are encoun-

tered with the integrity of the bulkhead or surrounding strata. To determine the impact of a bulkhead failure on active in-mine escapeways, the potential inundation area should be identified.

8.6 FOUNDATION-RELATED CONSTRUCTION AND OPERATIONS MONITORING

Observations of foundation conditions during construction and operation of impounding facilities are critical. During construction, foundation conditions including mine-related features are exposed, allowing the facility operator and engineer to assess conditions for consistency with expectations and to evaluate specific foundation preparation design measures. The operator and engineer responsible for construction certification should involve the designer during critical tasks such as construction/implementation of bulkheads and seals, cutoff trenches, and grouting programs. During construction, survey control to confirm locations of key features and the dimensions of associated structures is essential. Documentation of conditions with photographs and as-built drawings and reports of construction activity is important for certification of the work and for subsequent evaluation, if necessary. Additional discussion of construction monitoring is presented in Chapter 12. A discussion of construction and operations procedures and monitoring for bulkheads is provided in MSHA (2003), and key guidance from the MSHA document is presented in this section.

Where there are mine workings near an impoundment, the manner in which an impoundment is operated can affect the breakthrough potential. For example, measures should be taken to design and operate the impoundment in a manner that minimizes the presence of free water. Thus, decant raising should be staged so that the water level rises incrementally. Pumping can also be employed to minimize the volume of water in the impoundment. Mine personnel who work on or around the impoundment should be cognizant of key components of the operation plan and particularly of any unusual operational requirements.

A site-specific monitoring plan oriented toward breakthrough prevention and assessment of the potential for subsidence to affect the dam should be developed. Monitoring involves collection of information from both visual inspection of the impoundment and from instrumentation. Coal company personnel who inspect the impoundment, or who routinely work on or around the impoundment, should be trained to observe potential signs of trouble that could be related to subsidence effects or a breakthrough. These personnel should be aware of where underground mining has occurred and where to look for cracks or other evidence of subsidence. Signs that they should look for include: (1) unusual sudden drops in the pool level, (2) the presence of a whirlpool or bubbles in the pool, (3) cracking or sudden displacement in embankment surfaces, (4) unusual readings in piezometers, (5) changes in seepage conditions, and (6) changes in the quantity of flow and the amount of sedimentation in discharges from mine openings, backfilled mine openings, or outcrop areas. Instruments such as staff gages, weirs, survey monuments and inclinometers are useful for monitoring these conditions and detecting changes.

In determining what instrumentation should be installed and monitored, the designer should identify the parameters that will indicate how the site is performing with respect to potential failure modes. This will facilitate taking action if the facility does not perform as expected. The following items should be considered in developing a monitoring plan:

- Seepage – Seepage from the impoundment should be monitored, including seepage through the embankment, through any internal drainage systems, and through underground mines that receive seepage from the impoundment. Weirs or other devices should be installed so that flow rates can be easily and consistently measured. Changes in water quantity and quality in seeps and discharges (including mine/pump discharges) that are hydraulically connected to the impoundment should be monitored. Changes in seepage quantity, particularly when not correlated to rainfall or pool water levels, may indicate deteriorating or adverse conditions warranting additional investigation.

- Water levels – The pool levels in the impoundment and in underground mines should be monitored, and unexplained changes should be investigated. If there are bulkheads in the mine, the water pressure against them should be monitored. Where conditions with respect to breakthrough potential are uncertain, instrumentation can be installed to provide an alarm in the event of a sudden drop in the impoundment water level. The alarm would alert mine personnel to check on the situation and would facilitate early warning and emergency response in the event of a breakthrough failure.
- Piezometric levels – Saturation levels and water pressures in the refuse embankment, as well as in any other earthen barriers, should be monitored to determine whether hydrostatic pressures are within design limits and whether any changes or trends are reasonable. In situations where it is critical to be able to measure rapid or sudden changes in pore water pressure, a closed system such as a vibrating-wire piezometer should be used.
- Rainfall data – It is good practice to install a rain gauge in the vicinity of an impoundment, but it is especially important in situations where there is breakthrough potential and where discharges from a mine can be traced to seepage from the impoundment. In such cases, rainfall data should be routinely collected so that it can be determined whether changes in the water flow or water level data correlate to rainfall or may be occurring for other reasons.
- Ground movement – When there is potential for subsidence in the vicinity of an impoundment, the ground surface should be monitored for movement. Both horizontal and vertical movements should be measured.

The types and suitability of instrumentation for accomplishing these monitoring objectives are discussed in Chapter 13. The timely review and interpretation of instrumentation data by someone knowledgeable in the design and performance of impoundments is critical to an effective monitoring program.

The type and frequency of monitoring required depend on impoundment conditions. Typically, monitoring is performed during regular weekly inspections. Where conditions warrant, more frequent or even continuous automated monitoring may be needed. Monitoring plans should include provisions for plotting and evaluating the observed data in a timely manner. When a potentially hazardous condition develops, more frequent monitoring is required. 30 CFR § 77.216-3(b)(4) requires, in part, that when a potentially hazardous condition develops, the mine operator shall immediately direct a qualified person to monitor all instruments and examine the structure at least once every eight hours or more often, if requested by an authorized representative of MSHA.

8.7 MINE BACKFILLING DESIGN

Backfilling of mine workings is performed in order to provide localized support for pillars and the mine roof and to reduce the volume of open space that could potentially be filled with collapsed material, thus tending to minimize the deformation of the surrounding rock mass. Support for pillars and volume reduction of open space can be achieved by a variety of backfill types. While deformation and bulking of the roof strata can provide support for mine overburden, backfilling with grout to improve contact with the roof may be a desirable option. The most common types of fill material are waste rock, mill tailings, quarried rock, sand and gravel, and fly and bottom ash. Additives such as portland cement, lime, fly ash, and pastes can also be mixed with the fill to alter the characteristics and to improve the effectiveness of the backfill. Placement alternatives include stowing by hand, gravity, mechanical, pneumatic and hydraulic methods. Hydraulic placement is generally effective for the varying conditions encountered in mine workings.

Backfilling of mines has significantly reduced surface damage from subsidence by lending lateral support to pillars and by limiting the volume of voids (National Academy of Sciences, 1975). The most important consideration in mine backfill design is the planned backfill material. The mechanics of uncemented fill can be analyzed using soil mechanics principles (Coates, 1981). The strength of most uncemented hydraulic fills is related to frictional resistance to sliding between particles and can be affected by pore water pressure and erosion, as well as dynamic loads such as blasts or sudden fluctuations in the water table. Additionally, the compressibility of the backfill material is related to its ability to provide support for the pillars and roof.

Cemented backfill has cohesion resistance gained through the addition of cement or pozzolanic admixtures that render the backfill relatively incompressible. Backfill strength usually increases linearly with cement content, which can range up to 10 percent. The grain-size distribution of the fill may also be important. Well-graded material generally has a greater strength than uniformly graded material, although the fines content (i.e., minus 200 mesh portion) can adversely affect the strength. The inclusion of pozzolanic material additives such as fly ash can reduce the volume and associated cost of portland cement in a mine backfill while significantly increasing strength and providing other beneficial characteristics such as improved fluidity during placement. The strength and placeability of candidate cement mixes should be evaluated through laboratory testing.

Typically, mine backfill provides substantial filling of mine voids, such that relatively little bulking from roof materials is needed to mitigate fracturing of the overburden and the advance of subsidence in the overburden. In critical situations, the space between the backfill and the roof can be grouted. In instances where mine backfill provides support for the coal pillars but not direct support for the overburden, the mechanical behavior of the cemented fill can be modeled as providing lateral restraint according to the relationship (Cai, 1983):

$$\sigma_h = n \frac{\gamma H a}{K_p L} \quad (8-14)$$

where:

- σ_h = passive earth pressure (psf)
- n = correction coefficient (dimensionless)
- γ = unit weight of overburden (pcf)
- H = depth of overburden (ft)
- a = width of open space (ft)
- K_{pl} = coefficient of passive earth pressure of pillar (dimensionless)
- L = width of adjacent pillar (ft)

With lateral support from cemented backfill, the strength of a pillar increases according to the following formula (Guang-Xu and Mao-Yuan, 1983):

$$\sigma'_1 = \sigma_1 + \sigma_h K_{pl} \quad (8-15)$$

where:

- σ'_1 = strength of pillar supported by fill (psf)
- σ_1 = strength of pillar (psf)
- σ_h = passive earth pressure provided by fill (psf)

The supported pillars can then be analyzed for stability based on the procedures discussed in [Section 8.4.3](#). For instances of thin overburden, Mitchell (1983) and Wizniak and Mitchell (1987) present analytical procedures for estimating surface subsidence deformation for backfill placed to the mine roof wherein the roof is modeled as a beam on an elastic foundation.

The design of mine backfill generally depends on the availability of fill materials and fly ash and their associated costs.

8.8 SURFACE MINE SPOIL ISSUES

At some refuse disposal sites, surface mine spoil may be available in the foundation area, and some of this spoil may be suitable for use in constructing structural portions of refuse embankments such as the starter dam. Mine spoil is typically quite variable in terms of its composition of soil and rock materials and also relative to maximum particle or fragment size and distribution, durability and moisture content. Typical methods of spoil placement can also result in considerable segregation. This variability makes it difficult to characterize the engineering behavior of mine spoil, and thus the field and laboratory procedures described in Sections 6.4 and 6.5 may need to be modified to accommodate its special characteristics. This variability also can lead to difficulties in estimating engineering properties such as compressibility, shear strength and hydraulic conductivity. Piping in mine spoil materials is a concern and has been identified as the cause of sinkholes and black-water releases at slurry impoundment sites founded on mine spoil. When a coal refuse facility is to be constructed over or using surface mine spoil, designers should recognize the variable character and composition of the material and understand the potential impacts that it can have on the long-term performance of a coal refuse embankment.

8.8.1 Surface Mine Spoil Characteristics

Surface mine spoils result from excavation and placement of overburden and interburden materials. These operations typically range in size from several hundred to several thousand acres, and mine life is typically five to 30 years or more. Overburden removal is generally accomplished by continuous bucket-wheel excavators, walking draglines, hydraulic excavators, stripping shovels, scrapers, dozers, or cast blasting. Where unconsolidated materials such as glacial till or loess represent a significant portion of the overburden, bucket-wheel excavators are generally used.

Spoil placement is typically accomplished by dropping the spoil materials at the angle of repose to form a ridge of piles parallel to the active pit or by placing the materials in lifts where the lift thickness and degree of compaction depend on the equipment type, weight and number of passes.

Uncontrolled spoil placement is typically associated with contour and area mining, while placement in lifts is generally associated with haul-back mining and head-of-hollow and valley-fill construction. Before the late 1970s to early 1980s, spoil ridgetops were left as deposited or were graded with a single pass of a dozer that resulted in a ridge and trough topography. With the advent of state and federal regulatory programs to return mining operations to near their original contours, spoil ridges have been extensively graded with dozers leading to increased spoil handling and machinery traffic, greater breakdown of the spoil, higher density and improved engineering behavior of the in-place spoil. A discussion of the influence of mining method on the bulk density of spoil based on testing in the Eastern Coal Province is presented in Phelps et al. (1981).

Because of the material handling that occurs during excavation, deposition and placement, mine spoil materials experience significant changes in physical integrity. These changes are related to variations in geologic characteristics, moisture, stress regimes, mining and reclamation methods, and other environmental aspects of the materials. The physical deterioration of geologic materials caused by changes in stress conditions or strength characteristics is referred to as slaking. The most distinctive aspect of the slaking process is a relatively rapid decrease in the particle or fragment size of the material.

The decrease in particle or fragment size caused by slaking can have a wide range of effects on the behavior of the material in a spoil pile. These effects will depend on the gross characteristics of the spoil pile (e.g., physical dimensions and configuration of the pile and the degree of compaction), the durability of the pile materials, the proportion of slakable materials, and changes in the pile surficial or internal moisture regimes. Possible adverse effects of spoil slaking include: (1) decreases in material strength that can reduce the stability of slopes and (2) increases in moisture content and decreases in particle and fragment size that can increase settlement and surface erosion and affect hydrologic regimes and vegetation. In a study of the environmental effects of slaking of surface mine spoils in the eastern and central U.S., Andrews et al. (1980) observed that:

- The rate and degree of particle breakdown is directly related to the material characteristics (e.g., durability) and local environmental conditions (e.g., depth of burial).
- The most active zone of slaking occurs within about three feet of the exposed mine spoil surface.
- The major observed effect of mine spoil slaking is a decrease in particle or fragment size that results in changes to the hydrogeologic characteristics (e.g., rate of infiltration, hydraulic conductivity, rate of groundwater flow) of spoil piles
- The significance of slaking seems to be minimized by the mixing of slakable (e.g., mudstone and shale) and nonslakable (e.g., limestone) materials that usually occurs during typical spoiling operations.
- No gross environmental damages due to slaking were apparent at the sites visited.

Andrews et al. (1980) developed these observations through laboratory testing of bulk samples obtained from test pits excavated in 2-, 5-, and 10-year-old spoils from four mine sites located in the Appalachian Basin. Based on extensive qualitative and semi-quantitative data collected relative to the behavior, causes, and effect of slaking materials, the study identified three field slaking modes:

1. Slaking to a constituent grain size that typically occurs in mudstones and occasionally sandstones
2. Chip slaking to thin, platy fragments that generally occurs in shales, siltstones and occasionally thinly-bedded sandstones
3. Slab or block slaking to large, approximately equidimensional fragments that generally occurs in sandstones and limestones.

The lithology, bedding and mineralogical characteristics of the spoil materials were found to have a major effect on the mode, rate and degree of slaking. In general, mudstones, siltstones and shales were found to be the most slake-prone lithologies. Slaking of sandstone and limestone was variable, but generally minor. Bedding characteristics were the primary factor in the mode of slaking (i.e., rocks with thin bedding typically exhibited chip slaking whereas rock with a massive structure were prone to block or slab slaking, or to slake to their constituent particle size). Spoils that slake to their constituent particle size were found to be less stable, while spoils in which chip slaking or slab or block slaking dominates generally were found not to be associated with stability issues.

The engineering behavior of mine spoil may be related to mining techniques. In general, overburden removal by blasting, material transport and dumping by trucks, and placement and leveling by dozers results in mechanical breakdown that leads to reduced slaking once the material is placed.

8.8.2 Design and Construction Considerations

The compressibility, shear strength and hydraulic conductivity of mine spoil can vary considerably depending on the proportion of slakable and nonslakable materials and the methods used to place and reclaim the spoil. Test methods that can be used to assess the slaking potential of mine spoil are

presented in [Section 6.5.9.4](#). The application of these test methods as part of an overall management control process are described in Andrews et al. (1980). Figure 8.16 presents a system of classification and interpretation of spoil durability based on index and slake durability testing using the degradation index (DI), where $DI = 1 - I_d$ and I_d is the slake durability index. Based on conclusions and recommendations from the study, designers should consider the following measures in planning and conducting site reconnaissance, site exploration and laboratory testing programs and in developing designs and preparing construction documents:

- Review of available surface mining records in order to document the mining and reclamation practices used, the stratigraphy of overburden and interburden materials excavated, and the time frame for mining operations.
- Use of test pits to observe and document the general proportion of slakable and nonslakable materials, the type and amount of slakable material breakdown, the grain-size distribution and moisture content of bulk samples, and the existence of a permanent or perched water level in the spoil mass.
- Provisions to control seepage and prevent internal erosion through mine spoil zones under refuse facility structures, including cutoff trenches through spoil deposits or impervious blankets with filter layers.
- Measures to monitor the settlement and lateral displacement of foundation spoil materials as the refuse embankment is raised. A discussion of instrumentation is provided in Chapter 13.

If mine spoil is to be used for embankment fill, the variability of the spoil should be determined so that the embankment can be constructed in a manner that will allow the desired performance in terms of strength and hydraulic conductivity to be achieved. The strength of mine spoil is typically estimated by: (1) evaluating its angle of repose, (2) correlating with published values for rock fill if the material is durable, or (3) by testing the finer portion of the material, which typically results in a conservative estimation. Internal stability of non-uniform material can be a concern for mine spoil, particularly if it is gap-graded. The hydraulic conductivity of mine spoil is typically estimated based on grain size, and measures such as zoning may be required in order to address the variability of the material. Designers should consider the following measures, if mine spoil is to be used to construct some or all of a coal refuse embankment:

- The composition and variability of the mine spoil used for borrow should be determined using test pits to observe and document the general proportion of slakable and nonslakable materials, the type and amount of slakable material breakdown, the grain-size distribution and moisture content of bulk samples, and the chemical composition (i.e., pH and content of sulfide minerals in fine-grained constituents such as shale) of the spoil mass. Placement of slakable material in upstream zones (particularly when fine-grained) and nonslakable material in downstream zones in an embankment can provide a means of isolating the materials and taking advantage of their properties.
- If oversize material (e.g., greater than 12 inches in maximum dimension) is present, provisions to crush, mechanically degrade or isolate oversize materials should be incorporated into the construction specifications.
- If the chemical composition of any portion of the spoil mass is not acceptable, these materials should be isolated or excluded from the embankment.

The presence of mine spoil in the foundation zone of an impounding embankment may require measures to address settlement and the potential for internal erosion. The significance of such effects should be evaluated based on exploration, testing and analysis of the foundation and embankment

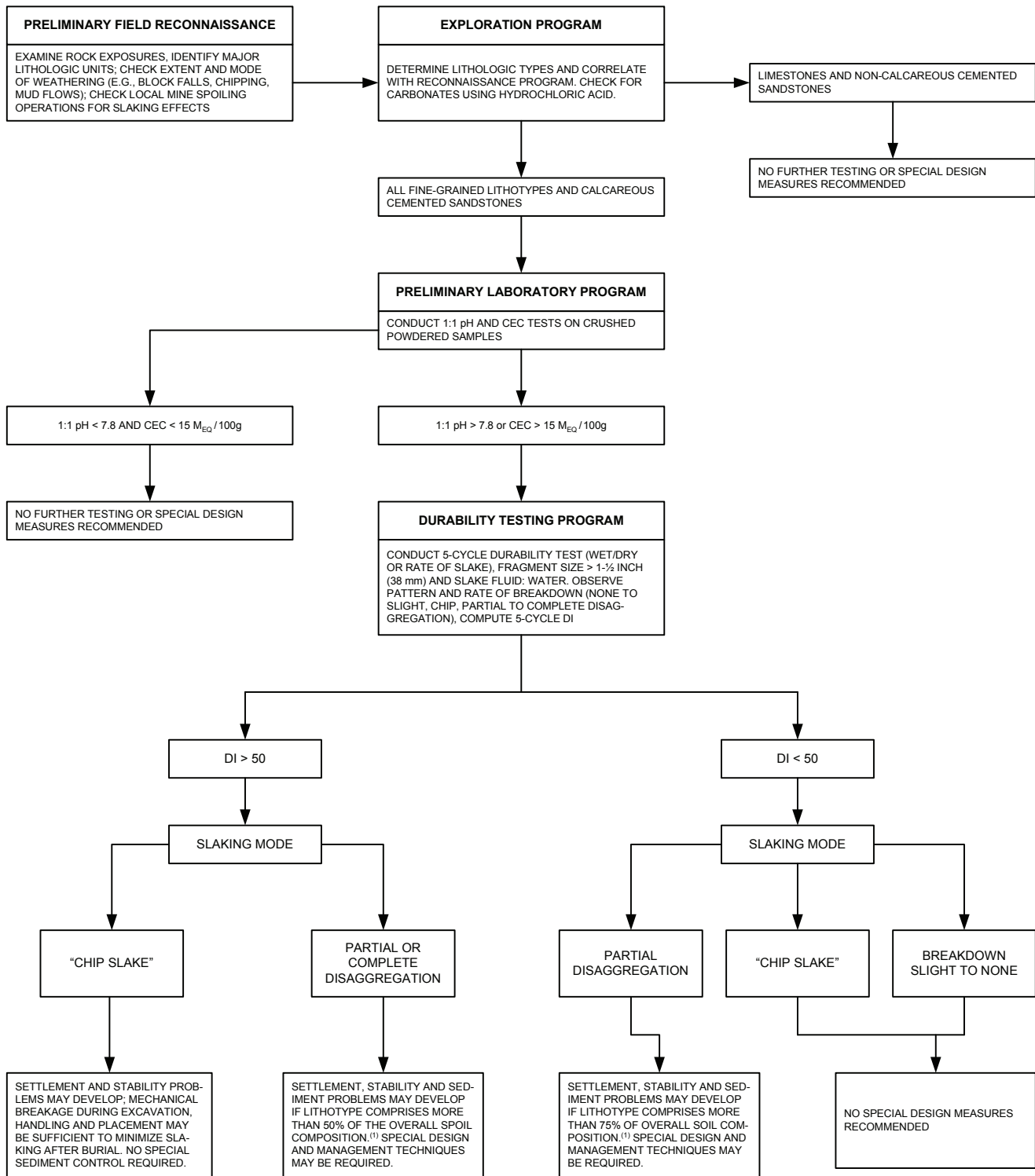

NOTE: 1. BASED ON HOMOGENEOUS MIXING OF LITHOTYPES DURING PLACEMENT

TESTING RESULTS
 CEC = CATION EXCHANGE CAPACITY
 M_{EQ} = MILLIEQUIVALENT
 DI = DEGRADATION INDEX = (1 - I_s)
 I_s = SLAKE DURABILITY INDEX

(ANDREWS ET AL., 1980)

FIGURE 8.16 CLASSIFICATION AND INTERPRETATION OF SPOIL DURABILITY

materials. Typical measures that are employed include: (1) compensating for settlements through staged construction by loading foundation zones using broad embankment widths and (2) providing sufficient gradient on drainage structures. The potential for internal erosion can be addressed by a variety of site preparation measures including the use of cutoff trenches with seepage barriers and filters.

8.9 SURFACE MINE HIGHWALL ISSUES

Surface mine highwalls represent foundation concerns for coal refuse disposal facilities, in that the change in rock surface elevation may represent an abrupt transition in an embankment abutment with the potential for: (1) embankment cracking due to differential settlement or (2) a zone of concentrated seepage due to the difficulty of placement and compaction of fill materials close to a near-vertical highwall. Additionally, surface mine benches and highwalls may contain fractured materials, particularly if they have been subjected to auger or highwall mining activities. Subsidence associated with such mine openings and remedial measures are discussed in [Sections 8.4.2.8](#) and [8.5.1.3](#). The discussion in this section focuses on abrupt rock transitions and associated seepage cutoffs.

Whenever a coal refuse embankment or earthen dam abuts a surface mine bench or highwall, there is a potential for performance problems due to the abrupt transition where the rock bench/highwall adjoins the earthen embankment. These potential performance problems include:

- Inadequate compaction of embankment materials against the rock surface sufficient to provide a low-hydraulic-conductivity contact between the earthfill and rock surfaces.
- Incomplete filling of surface cavities and depressions in rock surfaces with compacted embankment materials that can be sources of differential settlement and seepage.
- Overly steep rock surfaces and overhangs that limit the opportunity for maintaining positive compressive pressure over the full contact between earthfill and rock surfaces.
- Earthfill placed over rock surfaces with steep or abrupt slope transitions that can lead to differential settlement, cracking and elevated seepage in the earthfill.
- Highly fractured highwalls or benches resulting from mining or subsidence that represent potential seepage pathways that could impact downstream embankment and abutment areas.

To minimize these potential performance problems, rock benches and highwalls should be inspected during construction and should be treated or modified so that unacceptable conditions and performance problems do not occur. For earth embankment dams with an impervious core, these problems are of concern mostly where the impervious core abuts the rock surface. For coal refuse or other embankments that are constructed as homogeneous dams, the concern may be more significant because these structures do not have an impervious zone to serve as a barrier to internal seepage or seepage along abutment contacts.

If the control measures described in the following list cannot be fully implemented in a constructed embankment, special drainage features for intercepting and conveying seepage flows from the embankment should be considered. Fell et al. (2005), USBR (1984) and Sherard et al. (1963) describe a number of treatment and modification options for such performance problems, which may be encountered at water retention dams. Additionally, alternate measures are described that may be appropriate for coal refuse impoundments, but any such measure should be evaluated with respect to site-specific conditions. Guidance for addressing a number of conditions is provided in the following:

- Loose and weathered materials – The existing overburden and weathered rock should be excavated to competent rock, and the resulting rock slope should be

trimmed to a regular surface to eliminate depressions, overhangs, pinnacles or sharp transitions. This treatment should focus on the abutment cutoff zone, as illustrated in Figure 8.17, and should extend as warranted by site conditions and the embankment cross section. Sherard et al. (1963) noted that the most effective way to obtain a tight bond between earthfill and a rock surface is to slope the rock surface sufficiently to permit each embankment layer to be compacted directly against the rock using heavy compactors. Equipment operation above or below a highwall should be preceded by an evaluation of the highwall stability and development of appropriate procedures, if necessary, to address the threat of rockfalls or instability during grading and excavation.

- Overly steep rock slope – If the slope of a rock surface that will abut an earthfill is steeper than 0.5H:1V, the rock surface should be flattened by excavation or backfilling with concrete, or other measures should be taken to effectively place and compact the embankment materials. Alternate measures could include incorporation of impervious zones, incorporation of internal drainage features, or broadening of the embankment. The same cautions discussed above relative to working near a highwall apply.
- Hydraulic cutoff – If flattening is not practical due to the height of the rock slope, a cutoff keyway can be excavated into rock, or other measures to control seepage along the rock interface may be implemented. The depth of a cutoff keyway should extend a sufficient depth (e.g., six feet as per Fell et al., 2005) into competent rock, and the width of the keyway should be sufficient to permit compaction of earthfill in the cutoff in accordance with embankment criteria. Alternate measures to mitigate seepage could include incorporation of internal drainage features or broadening of the embankment-abutment contact.

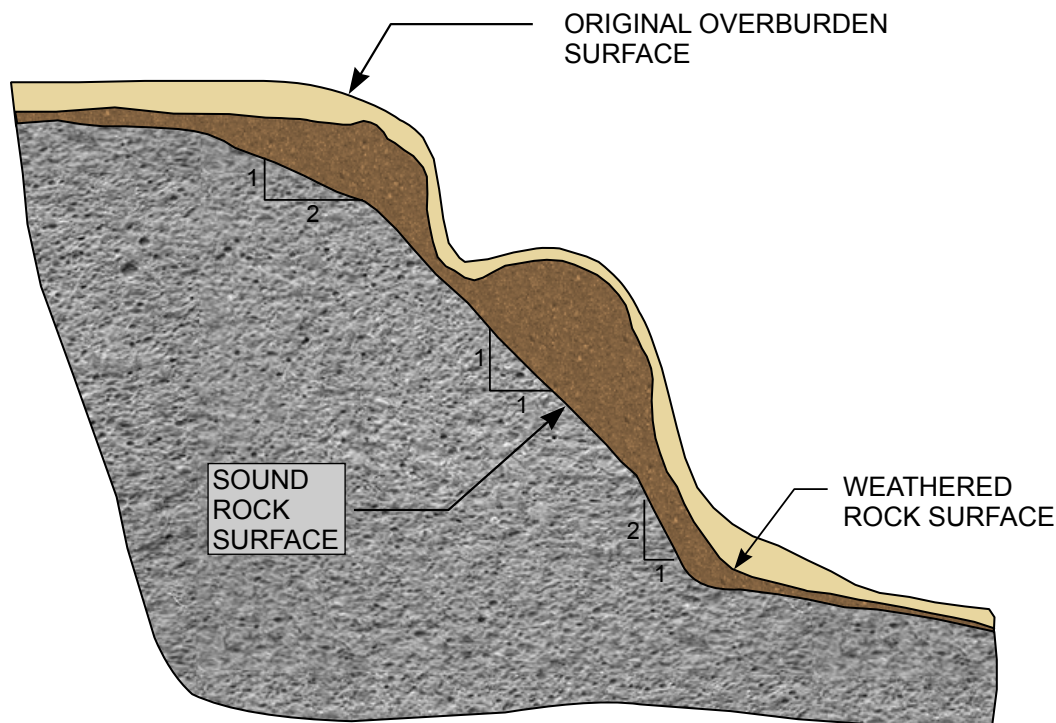

NOTE: SEEPAGE CUTOFF NOT SHOWN.

(PRATT ET AL., 1972)

FIGURE 8.17 EXCAVATION SLOPES FOR PREPARATION OF DAM ABUTMENTS IN ROCK

- Steep, abrupt transitions in rock grade – Steep, abrupt transitions in rock grade should be trimmed (Figure 8.18) to minimize the potential for impacts of differential settlement in compacted earthfill susceptible to cracking (e.g., cohesive fill) above the transition. The same cautions discussed above relative to working near a highwall apply.
- Clay-filled seams or very weathered rock – Clay-filled seams or very weathered rock should be excavated and filled with concrete (or grouted) to prevent erosion of the seams. Treatment should focus on the abutment cutoff zone and should extend upstream and downstream to the extent warranted by the site conditions and the embankment cross section. The U.S. Bureau of Reclamation (USBR, 1984) recommends that seams narrower than 2 inches be cleaned to a depth of three times the seam width and that seams between 2 inches and 5 feet wide be cleaned to a depth of three times the seam width or to a depth where the seam is ½ inch wide or less. To avoid unnecessary excavation of stable seam material that would be held in place by concrete and subsequent earthfill, engineering judgment should be used to determine the reasonableness of these guidelines in light of site-specific conditions. Perin (2000) presents a case history that addresses treatment of stress relief fractures at a coal refuse disposal facility.
- Irregularities on slopes not steeper than 0.5H:1V – These irregularities may be treated using dental concrete, pneumatically-applied mortar or slush concrete grout, as illustrated in Figure 8.19. The extent of treatment can be limited to the abutment cutoff zone, as warranted, or may extend throughout the abutment area depending on site-specific conditions and the breadth of and material types in the embankment cross section. Generally the following treatments are considered for structures that

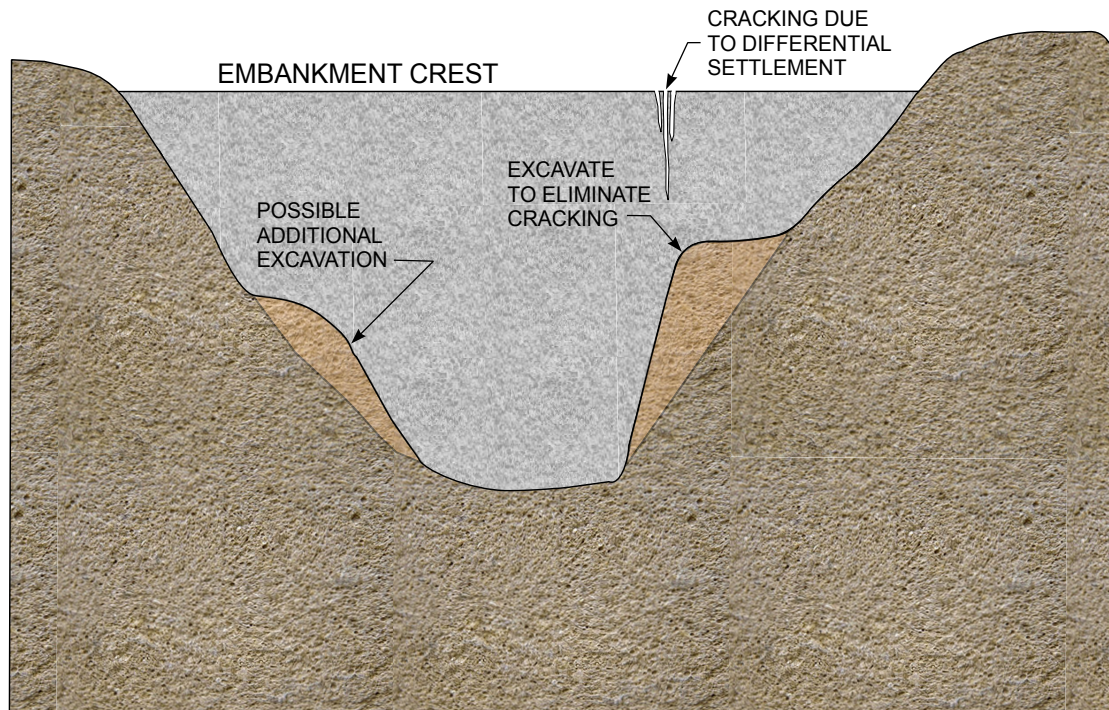

(FELL ET AL., 2005)

FIGURE 8.18 SLOPE MODIFICATION TO REDUCE DIFFERENTIAL SETTLEMENT AND POTENTIAL FOR CRACKING

may impose significant hydraulic head in the vicinity of the irregularity (e.g., water retention dams):

Dental concrete should be used to fill joints, bedding, sheared zones, overhangs or excavated surfaces, particularly in the abutment cutoff zone. Fell et al. (2005) recommend that dental concrete slabs have a minimum thickness of 6 inches, a minimum 28-day compressive strength of 3,000 psi, and a maximum aggregate size not more than one-third the depth of the slab or one-fifth the narrowest dimension between the rock surface and the edge of the form. Feathering at the ends of slabs should not be permitted, and slab edges should be sloped no flatter than 45 degrees. To achieve good bond between the rock surface and the concrete, the rock surface should be thoroughly cleaned and moistened prior to concrete placement. The finished concrete surface should have a roughened, broomed surface to facilitate earthfill placement. Sulfate-resistant cement should be used in the concrete.

Pneumatically-applied mortar (shotcrete) can be used as an alternate to dental concrete provided that care is taken that it is applied in a manner consistent with the recommendations for dental concrete.

Slush concrete grout is a neat cement grout or sand-cement slurry used to fill narrow surface cracks or to serve as a temporary cover over slakable materials that degrade rapidly upon exposure to air and water. Slush grout may be applied by brooming, troweling, pouring, rodding, or funneling into individual cracks (Fell et al., 2005). To facilitate adequate bond, the rock surface and cracks should be cleaned and moistened before the slush concrete grout is applied.

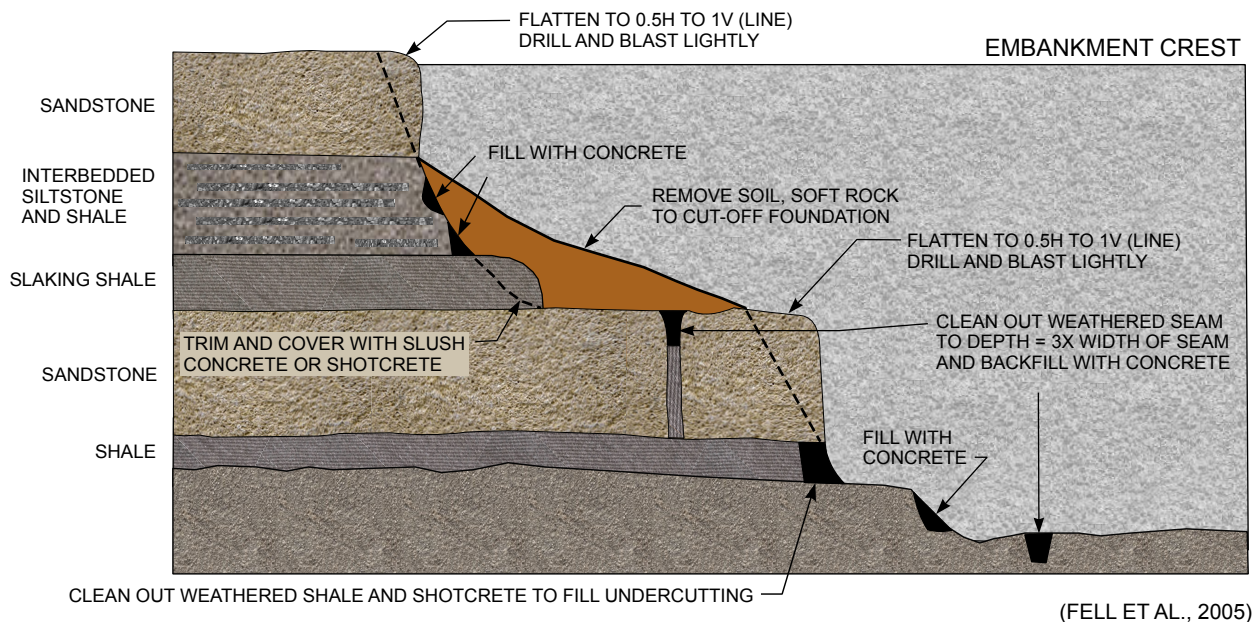

(FELL ET AL., 2005)

FIGURE 8.19 SLOPE MODIFICATION AND SEAM TREATMENT FOR SEDIMENTARY ROCK STRATA

In some situations, grouting of extensively fractured surface mine benches and highwalls may be more appropriate than other treatments discussed above because of the depth or extent of disturbance. Table 8.6 presents general guidance for cement grout programs (Fell et al., 2005) that may be useful for highly fractured rock foundations. USACE (1984a) and Fell et al. (2005) provide further guidance for evaluation, design and implementation of grouting programs, including the use of chemical grouts for limited applications.

TABLE 8.6 GUIDELINES FOR CEMENT GROUT PROGRAMS

Staging of Grout Program	Downstage	Top section of hole is drilled and washed, pressure tested, grouted and allowed to set for 24 hours. Top section of grout is then washed out then second stage is drilled and washed, pressure tested, grouted and allowed to set for 24 hours. Upper sections of grout are then washed out then third stage is drilled and washed, pressure tested and grouted. Use of packer allows increased pressures.			
	Upstage	Hole is drilled to full depth and washed, packer is seated at the top of the bottom stage, pressure tested, grouted, and allowed to set for 6 hours. Set packer at top of second bottom stage, pressure test, grout, and allow to set for 6 hours. Continue remaining stages.			
	Full Depth	Hole is drilled to full depth and washed, pressure tested, grouted. Only recommended for consolidation grouting.			
Closure Criteria	No further grouting is needed when:				
	Erodibility of Foundation ⁽¹⁾	Pressure Test Value Before Grouting (Lugeon) ⁽³⁾	Reduction in Lugeon Value or Grout Take from Previous Stage ⁽²⁾ (Lugeon) ⁽³⁾	All Grout Takes (kg cement/m)	Grout Hole Spacing (m)
	Low/Non	< 10	< 20	< 25	< 1.5
	High	< 7	< 15	< 25	< 1.5
	<p>Note: 1. Erodible foundations would include extremely or highly weathered rock and rock with clay-filled joints that might erode under seepage flows.</p> <p>2. For rock with joints closer than 0.5m.</p> <p>3. Tabulated values are for Type F portland cement; for Type A portland cement, adopt Lugeon values 20 percent greater. One Lugeon is a flow of 1 liter/minute/ meter of borehole under a pressure of 1000 kPa. In a 75-mm borehole, one Lugeon equivalent to approximately 1.3×10^{-7} m/sec hydraulic conductivity.</p>				
Depth and Lateral Extent	So far as practical, grout holes should be taken to the depth and extent necessary to meet closure criteria. Rules of thumb are not recommended. In nearly horizontally layered rock, geologic interpretations may provide a guide where testing is unavailable in the valley floor, but may be at different depths and orientations around the abutments due to the influence of stress relief, weathering, and rock types.				
Grouting Effectiveness	Cement Grout Particle Size	Cement particles are mostly silt size, but include some fine sand particles in conventional cement. With plasticizers, Type A and C Portland cements have a maximum particle size of about 0.05 to 0.08 mm, while microfine cements may be about 0.02 mm.			
	Fracture Size	Minimum Lugeon values are indicative of rock that will accept cement grout			
	Cement	1 Fracture/m	2 Fractures/m	4 Fractures/m	
	Type A	8	16	32	
	Type C	5	10	20	
	MC-500 (microfine)	3	5	10	
	Type A with dispersant	8	16	32	
	Type C with dispersant	5	10	20	
MC-500 dispersant	1	2	4		
	Note: Fractures are assumed to be rough and uniform width and grout is assumed to have been treated with plasticizer.				

TABLE 8.6 GUIDELINES FOR CEMENT GROUT PROGRAMS
(Continued)

		Approximate Penetration from Borehole of Grout (m)				
		Fracture Spacing				
Grout Penetration	Lugeons	1m	0.5m	0.25m		
		100	20	12	4	
		50	12	3	2	
		20	3	1.5	1	
		10	2	1	NP	
		5	1	NP	NP	
		1	NP	NP	NP	
Note: NP indicates that grout will not penetrate the fractures.						
Practical Aspects	Grout Holes	30 to 60 mm percussion drilling and washing of borehole.				
	Standpipes	Threaded galvanized pipe just larger than drill size, grouted into borehole to enable near surface grouting.				
	Grout caps	Necessary when grouting closely fractured or low strength rock where standpipe cannot be sealed into rock.				
	Grout Mixers	High speed, high shear, colloidal mixers.				
	Agitators	Slow speed designed to prevent cement particle settling.				
	Grout Pumps	Helical screw pumps or ram type pumps.				
	Packers	Mechanical or inflatable.				
	Water Cement Ratio	Starting mix: most sites – 2:1, for rock < 5 Lugeons – 3:1, for rock > 30 Lugeons – 1:1; for very high losses – 0.8:1; for heavily fractured, dry rock – 4:1, and for above water table where excess water is absorbed by dry rock – 5:1.				
		Thicken mix: (1) to deal with severe leaks, (2) after 1½ hours with continued take, or (3) if hole is rapidly taking grout (e.g., > 500 liters in 15 minutes).				
	Grout Pressure	Recommend avoiding rock fracturing. Start at 100 kPa or less for 5 minutes, then steadily increase over next 25 minutes. Occurrence of fracturing can be detected by sudden loss of grout pressure at top of hole due to increased take. Recommend grouting to refusal or minimum take.				
	Monitoring	Parameters: (1) hole location, orientation, and depth, (2) stage depths, (3) water pressure test value for each stage, (4) grout mixes, (5) grout pressures (e.g., 15-minute intervals), (6) grouting times, (7) leaks, uplift, (8) total grout take for each stage, (9) amount of cement in these takes, and (10) cement takes/unit length of hole.				
Water Pressure Test	Before grouting, apply water pressure and monitor for 15 minutes.					
Stage Lengths	Based on geologic conditions, minimum drill run, allowable pressures in upper part of hole, rock fracture conditions and hole stability, water flows into the hole, and large water pressure tests or grout takes.					

(ADAPTED FROM FELL ET AL., 2005)

Chapter 9

HYDROLOGY AND HYDRAULICS

Coal refuse impoundments and embankments must handle the runoff from precipitation that occurs over the contributing watershed area. If not properly controlled, runoff can jeopardize the collection and conveyance system (channels and conduits). For impoundments, runoff can cause the embankment to be overtopped with the potential for failure. The principles of hydrology and hydraulics can be used to determine and design the required combination of flow capacity and freeboard and to select durable channel lining systems. The discussion of technical issues in this chapter is based on the assumption that the reader is experienced in the technical areas of hydrology and hydraulics and is familiar with the selection of hydrologic and hydraulic design parameters and the use of related computer software. A number of traditional design concepts are reviewed herein, and reference is made to additional resource materials.

The design of coal refuse disposal facilities requires a somewhat specialized approach. There are many possible combinations of disposal facility configuration, facility staging, environmental considerations and unique characteristics and properties associated with each site. Therefore, one of the major aims of this chapter is to relate fundamental engineering principles to the unique requirements of refuse disposal facility site design. While primarily focused on slurry impoundments, the contents of this chapter are also applicable to other mining dams and impoundments.

The hydrologic and hydraulic information and design procedures presented in this chapter fall into five interrelated categories, as follows:

- Basic definitions and principles – [Sections 9.1](#) and [9.2](#) define basic terms and conditions applicable to coal refuse disposal facilities that relate to hydrologic and hydraulic features. [Table 9.1](#) presents a complete summary of hydrologic and hydraulic planning and design procedures. The table also serves as an outline of this chapter and a summary of supplemental references. The fundamental interrelationships of runoff, reservoir storage, and outflow are established. The major elements that may affect these interrelationships at coal refuse disposal facilities are also discussed.
- General design considerations – [Section 9.3](#) identifies regional and site conditions that affect the suitability of various hydraulic conveyance structures for coal refuse disposal facilities. In [Section 9.4](#), these broad concepts are extended to consider the effect of disposal facility configuration upon selection of suitable hydraulic convey-

ance structures. Characteristics that distinguish coal refuse disposal facilities from conventional embankment dams are emphasized.

- Design-storm criteria – [Section 9.5](#) presents design storm precipitation criteria for coal refuse disposal facilities. Factors such as location, facility size, and hazard potential are discussed. Design storm criteria for short-term conditions and for minor hydraulic structures are also addressed.
- Procedures for analysis – [Sections 9.6, 9.7](#) and [9.8](#) discuss analytical procedures for evaluation and design of coal refuse disposal facility hydraulic structures. Methods for determining runoff based on predicted precipitation are first established, followed by reservoir storage and outflow capacity requirements. Various components of outflow structures are discussed in detail. Procedures for routing storm runoff through an impounding disposal facility and optimizing reservoir storage and outflow are presented.
- Dam-breach analysis – [Section 9.9](#) discusses procedures for evaluation of dam breach and potential downstream inundation for the determination of hazard potential and for Emergency Action Plan (EAP) preparation.

9.1 GENERAL CONSIDERATIONS

The hydrologic and hydraulic design and analysis procedures discussed in this chapter apply to both existing and new coal refuse disposal facilities. The sequence presented in [Table 9.1](#) is normally followed either for modifying an existing disposal facility or for constructing a completely new disposal facility. It should be recognized that sequencing of a modification to an existing coal refuse disposal facility should be continually coordinated with the ongoing mining and coal preparation operations.

The designer of a new coal refuse disposal facility normally has flexibility in site selection, staging of the embankment growth and long-term planning of related hydraulic structures. Given this flexibility, design flood requirements can typically be met throughout the entire life of the disposal facility. Often the designer is able to optimize the relationships between refuse disposal operations, embankment design, hydraulic structure construction, and the overall mining and coal preparation operations.

A designer modifying an existing disposal facility should first determine its conformance with current design storm criteria and should then assess options for any necessary upgrade of the runoff collection and control system. Sometimes a facility has limited storage or hydraulic conveyance capability, may not satisfy current design and regulatory requirements, and cannot be easily modified in a short period of time. An effective solution may be to perform a staged modification program, as part of continued refuse disposal operations, which may in fact provide materials necessary for increasing freeboard and constructing diversions, thus improving hydraulic capacity. Under such conditions, the modifications to the facility are usually required to meet or exceed MSHA's short-term hydrologic design criteria, as subsequently described in [Section 9.5.2](#).

9.2 HYDROLOGY AND HYDRAULICS PRINCIPLES

Hydrology is the study of climatic and physical conditions that govern natural flows in rivers, streams and channels. Hydrologic analyses are used to determine the probable and possible direct runoff to a particular site from natural causes such as precipitation or snow melt. Hydraulics is the study of water flows in channels and conduits. Hydraulic engineering is used in the design of decant systems, outlet works, spillways, ditches, channels, diversion structures, and other systems for controlling flowing waters. An integrated application of hydrology and hydraulics is necessary for the development of safe, economical and environmentally acceptable coal refuse disposal facilities.

TABLE 9.1 HYDROLOGIC AND HYDRAULIC DESIGN PROCEDURES FOR COAL REFUSE DISPOSAL FACILITIES

Design Considerations	Applicability		Manual Sections for Reference	Supplemental References
	All Facilities	Impounding Facilities		
I. Determine Importance of Hydrologic and Hydraulic Considerations				
Type of facility	X		Chapter 3, 9.4	USBR (1987a)
Impounding vs. non-impounding			9.4	USBR (1987a)
Site conditions	X		Chapter 5, 9.5	USBR (1987a)
Downstream conditions	X	(Of particular concern)	9.3, 9.5	USBR (1987a)
Startup, operation, abandonment requirements	X		Chapters 4, 6, 9	
II. Establish Preliminary Facility Configuration and Hydraulic Systems				
Select structure type	X		Chapter 3, 9.4	
Balance availability of materials for embankment construction with facility staging	X		Chapter 5, 9.3, 9.4	
Determine size and potential hazard classification based on dam breach analysis and downstream inundation		X	9.5, 9.9	FEMA (2004a)
Determine appropriate design storm for long-term operation	X		9.5	MSHA (2007)
Determine if separate design consideration should be given to short-term conditions with lesser design storm at any time during the operational period of the facility	X		9.4, 9.5	MSHA (2007)
Calculate watershed contributing to major hydraulic systems	X		9.3	
Determine approximate inflow rates and volumes to be controlled by major hydraulic systems from design storm criteria	X		9.6	NWS (2006a,b) NRCS (2004b)
Evaluate alternative combinations of spillway outflow and impoundment storage capacities		X	9.6 to 9.8	USBR (1987a) NRCS (2004b) Brater et al. (1996)
Determine preliminary spillway type, location and approximate size (for all stages of operation)		X	Chapter 5, 9.6 to 9.8	USBR (1987a) Brater et al. (1996)
Determine preliminary decant type, location and approximate size (for all stages of operation)		X	Chapter 5, 9.6 to 9.8	USBR (1987a) Brater et al. (1996)

TABLE 9.1 HYDROLOGIC AND HYDRAULIC DESIGN PROCEDURES FOR
COAL REFUSE DISPOSAL FACILITIES
(CONTINUED)

Design Considerations	Applicability		Manual Sections for Reference	Supplemental References
	All Facilities	Impounding Facilities		
Determine magnitude of storm that can be controlled and compare with appropriate design storm for facility size and potential hazard classification	X		9.5 to 9.9	USBR (1987a) NRCS (2004b)
Evaluate modifications to be made to improve the facility's hydraulic system	X		Chapter 6, 9.5 to 9.8	USBR (1987a)
Evaluate advantages and disadvantages of modifying the facility for continued use or to a satisfactory configuration for abandonment	X		Chapter 6, 9.4 to 9.8	
Assign appropriate long-term design storm or abandonment criteria	X		9.5	FEMA (2004c)
III. Determine Design Inflow Rates and Volumes for Major Hydraulic Systems				
Determine if key parameter curves are suitable for final design for any or all stages, including abandonment	X		9.4, 9.6	
Determine inflow hydrograph parameters, if required, for any stage of development	X		9.6	NRCS (2004b) USBR (1987a)
IV. Design Major Hydraulic Systems				
Design major diversion system to insure against failure during appropriate design storm				
<ul style="list-style-type: none"> Collection of inlet area 	X		9.7	Chow (1959)
<ul style="list-style-type: none"> Establish control section of flow (inlet, transport section or outlet) 	X		9.7	USBR (1987a) Henderson (1966) Brater et al. (1996)
<ul style="list-style-type: none"> Determine requirements to prevent failure by overtopping, erosion or clogging 	X		9.6 to 9.8	USBR (1987a)
<ul style="list-style-type: none"> Determine downstream outlet and/or discharge requirements to avoid unacceptable damage at design flow 	X		9.7, 9.8	Chow (1959) USBR (1987a) Brater et al. (1996)
Determine optimum combination of storage and outflow for each stage of development (for impoundments)				
<ul style="list-style-type: none"> Perform reservoir routing analysis of inflow hydrograph 		X	9.6 to 9.8	USBR (1987a)
Design the spillway system for the appropriate design storm for each stage of development				

TABLE 9.1 HYDROLOGIC AND HYDRAULIC DESIGN PROCEDURES FOR COAL REFUSE DISPOSAL FACILITIES (CONTINUED)

Design Considerations	Applicability		Manual Sections for Reference	Supplemental References
	All Facilities	Impounding Facilities		
<ul style="list-style-type: none"> Establish control section for all flow conditions to assure adequate capacity 		X	9.6 to 9.8	Chow (1959) USBR (1987a) Henderson (1966) Brater et al. (1996)
<ul style="list-style-type: none"> Design the inlet including provisions to prevent clogging 		X	9.8	USBR (1987a)
<ul style="list-style-type: none"> Design the outlet to prevent unacceptable damage at magnitude of flow 		X	9.8	FHWA (2006) USBR (1987a)
Design the decant system for normal operating conditions and to evaluate impoundment storage of design storm				
<ul style="list-style-type: none"> Establish flow control for all storage levels to assure adequate capacity 		X	9.6, 9.8	USBR (1987a) Brater et al. (1996)
<ul style="list-style-type: none"> Design the inlet, including provisions to avoid clogging 		X	9.8	USBR (1987a) Brater et al. (1996)
<ul style="list-style-type: none"> Design the transport section, considering structural stability, corrosion resistance, and capacity 		X	9.8	USBR (1987a) Brater et al. (1996) FHWA (2005b)
<ul style="list-style-type: none"> Design the outlet to prevent unacceptable damage 		X	9.8	USBR (1987a) FHWA (2006)
Perform dam breach analysis and evaluate downstream inundation		X	9.9	FEMA (2004c)
V. Design Minor Hydraulic Systems				
Surface drainage ditches that are not critical to safety during design storm	X		9.6, 9.8	USBR (1987a) FHWA (2005a) FHWA (2006)
Minor roadway culverts	X		9.6, 9.8	FHWA (2005b) FHWA (2006)
Weirs to separate seepage from large flows, if required, for environmental control	X		9.8	Henderson (1966)

9.2.1 Basic Design Principles

The fundamental principle governing the hydrologic and hydraulic design of a coal refuse disposal facility is that runoff, natural drainage and process water must be conveyed past the embankment, stored within the facility impoundment(s), or handled by a combination of these two methods. The hydrologic characteristics of the applicable watershed (rainfall, tributary area, land use cover conditions, soil type, slope, etc.) determine the runoff hydrograph, while the physical dimensions and hydraulic characteristics of the facility and hydraulic structures determine the required conveyance and storage capacity. [Table 9.2](#) presents a summary of the application of the basic design principles to coal refuse disposal facilities.

TABLE 9.2 HYDROLOGIC AND HYDRAULIC DESIGN CONSIDERATIONS FOR COAL REFUSE DISPOSAL FACILITIES

Embankment Type ⁽¹⁾	Runoff, Outflow and Storage Considerations
Valley-Fill and Side-Hill Non-Impounding Embankments	<p>If placement of the embankment is started at the upper end of the valley, runoff from the natural watershed can be diverted around the embankment and no water has to be stored. Precipitation on the embankment can be directed downstream.</p> <p>If placement is started by forming a downstream embankment, it will have a temporary character with interim diversion ditches sequentially replaced as the fill is raised (sometimes the final diversion ditches are installed initially). Precipitation and runoff on the embankment are directly discharged downstream with the intervening drainage between the final diversion ditch and the interim diversion ditches.</p>
Ridge and Heaped Non-Impounding Embankments	<p>Ridge and heaped embankments that are constructed above the natural topography only have inflow associated with direct rainfall onto the disposal area. Precipitation and runoff on the embankment can be directed downstream.</p>
Cross-Valley Impounding Embankment	<p>The cross-valley impounding embankment presents a variety of alternatives for handling hydrologic events. Inflow may include precipitation from upstream of the embankment, including the drainage area above diversion ditches, unless the ditches are designed not to fail from the design storm.</p> <p>For a cross-valley impoundment, the three possibilities for handling design storm inflow are:</p> <ol style="list-style-type: none"> <li data-bbox="570 1083 1409 1192">1. If the embankment crest elevation is maintained sufficiently high above the pool level, all runoff from the design storm can be stored, such that outflow is not a requirement during the design storm. The impounded water can then be lowered gradually by flow through a decant system. <li data-bbox="570 1226 1409 1335">2. If a spillway of adequate size is constructed with its crest at the normal pool level of the impoundment, all of the storm runoff can be passed directly through the disposal area and the storage requirement will be minimal. <li data-bbox="570 1369 1409 1503">3. If the spillway crest is located above the normal pool level, but the storage volume between the pool and spillway elevations is less than the inflow volume, the spillway must be designed to conduct a volume equal to the difference between inflow volume and storage volume in an appropriate time interval.
Side-Hill Impounding Embankment	<p>A side-hill impounding embankment can have all of the alternatives of a cross-valley impoundment except that the smaller watershed and the potential for diversion significantly reduce the storage and outflow requirements associated with the design storm.</p>
Diked-Pond Embankment	<p>Normally, a diked-pond embankment will have inflow equal to the precipitation falling directly into the impoundment. Total storage with limited or no outflow during the design storm is normally the best solution, although the drawdown requirement must be met by either a spillway, decant pipe, or pumping.</p>
Incised Pond	<p>An incised pond has a water surface below the normal ground surface, and inflow runoff, storage and outflow generally are not critical to safety.</p>

Note: 1. Embankment types are discussed in Chapter 3.

In general, for non-impounding coal refuse disposal facilities or the downstream or perimeter portions of impounding facilities or slurry cells, runoff is conveyed around the facility without retention and storage. On the other hand, impounding embankments are designed to temporarily store runoff from upstream areas and to convey excess flows past the embankment with decant pipes and spillways.

Design criteria for impounding and non-impounding coal refuse disposal facilities include the total volume of runoff from the design storm, as discussed in [Section 9.5](#). For a non-impounding coal refuse disposal facility, the peak runoff rate caused by a flood or the design storm is of prime concern. For an impounding facility, both the peak runoff rate and the total volume of runoff are of concern. In the first case, the hydraulic facilities must be sized to pass the peak runoff rate, while in the latter case, the impoundment and hydraulic structures must be designed to store and pass the total volume of runoff.

The runoff and outflow elements are influenced by a number of critical factors, as discussed in the following section.

9.2.2 Definition and Discussion of Key Runoff Elements

Sources of impoundment inflow are shown in [Figure 9.1](#). These sources also include ancillary flow contributions such as process water (water or water-slurry mixture pumped from the mine or the coal processing plant), indirect runoff from adjacent watersheds, or other diverted flows such as from underground mines. The sources of impoundment inflow can be categorized as follows:

Major Sources

- Direct precipitation – rain or snow falling directly onto the disposal site
- Runoff – from precipitation falling on areas upstream or upgradient from the site and within the watershed associated with the facility

Minor Sources

- Springs from groundwater flow
- Base flow in a stream passing through or by the site that is relatively independent of the most recent rainfall events, but directly related to infiltration associated with earlier rainfall events
- Process water and other pumped flows

Minor sources of flow are typically much smaller than the major sources of runoff. The volumes associated with minor sources can be determined with relative accuracy. However, the amount of runoff resulting from a storm will vary depending upon site location. Geographic location, climatic conditions and watershed characteristics all contribute to storm runoff, as discussed in the following sections.

9.2.2.1 Watershed Boundary and Area

The watershed is all of the catchment area that drains toward a particular point of interest. Watershed boundaries are typically determined from site-specific topographic maps ([Section 6.4.1.1](#)) or USGS topographic quadrangle maps, as shown in [Figure 9.2](#).

9.2.2.2 Precipitation

Runoff results from precipitation falling on the watershed, melting of snow already on the ground and outflow from upstream impoundments in the watershed. Snowmelt is usually a minor portion of runoff in small watersheds, such as those usually associated with a coal refuse disposal facility. The effects of upstream impoundments should be considered on an individual site basis.

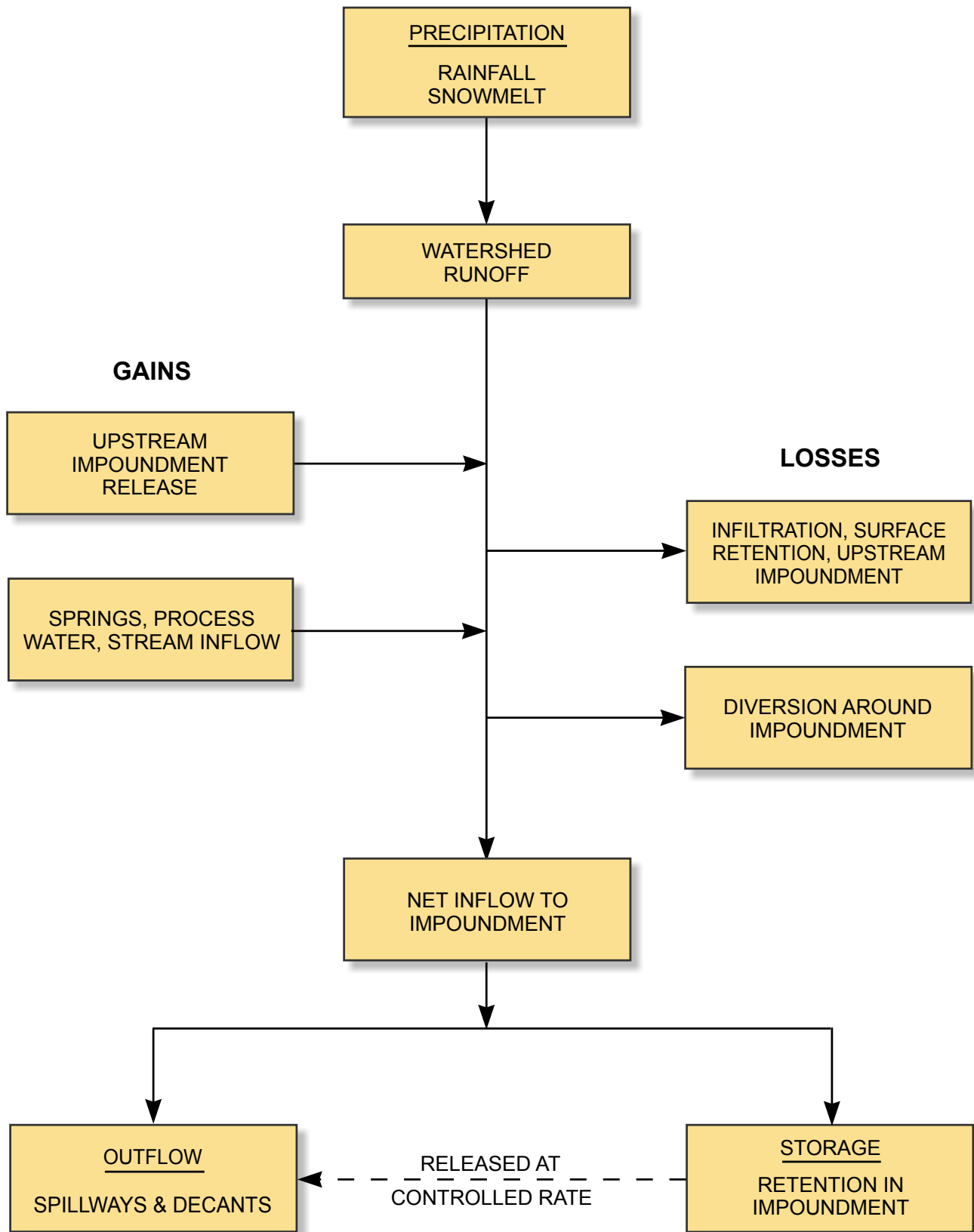

FIGURE 9.1 RUNOFF AND IMPOUNDMENT INFLOW SOURCES

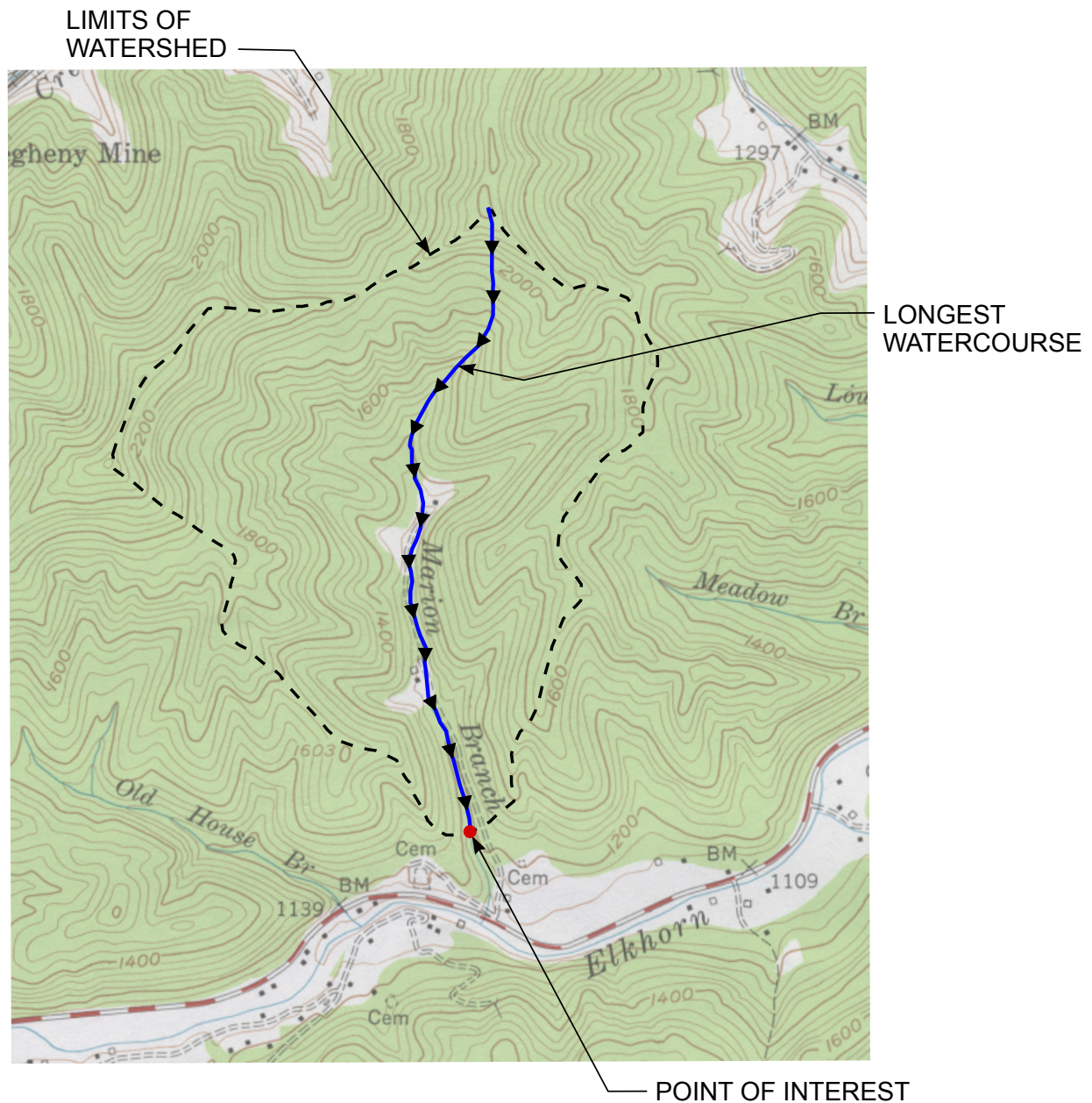

FIGURE 9.2 WATERSHED BOUNDARY DELINEATED ON USGS TOPOGRAPHIC MAP

9.2.2.2.1 Rainfall Curves

Calculation of the design storm rainfall (Section 9.5) involves determination of the total amount and distribution of rainfall for the entire storm duration. The relationships between total precipitation (cumulative rainfall depth), storm duration, and storm intensity (slope of the rainfall distribution curve) have a direct effect on the runoff rate and volume (Sections 9.6.1 and 9.6.2). For example, a sudden short rainfall can result in a high runoff rate and a small total volume of runoff, while a prolonged rainfall of low intensity can produce a large total volume of runoff with a relatively low runoff rate. Coal refuse disposal facilities should be designed to accommodate all possible precipitation/runoff conditions associated with the design storm.

9.2.2.2.2 Rainfall Intensity

The relationships between rainfall intensity, duration of the rainfall event and frequency (i.e., intensity-duration-frequency or I-D-F) can be used to determine the peak runoff, and are useful in the

design of hydraulic structures such as culverts, channels and ditches (Sections 9.6.3 and 9.6.4). Only the most intense portion of the rainfall, not the entire storm history, governs the selection of culvert size, the most efficient ditch or channel configuration, and the required erosion protection associated with the runoff flow velocity.

9.2.2.3 Watershed Characteristics

A portion of the precipitation falling on a watershed is retained in the soil and by vegetation or may be retained in upstream impoundments. The portion of the precipitation that flows to the point of interest is termed the runoff. The watershed characteristics that determine the difference between the amount of precipitation falling on the watershed and the amount that becomes runoff include: (1) the types of surficial soils and their effect on infiltration; (2) the condition of the ground surface (e.g., wet, dry, snow-covered or frozen) prior to the precipitation (termed the antecedent moisture condition); (3) the type and density of vegetation; (4) development features such as paved surfaces, channeling, storm sewers, etc.; and (5) the presence of dams, lakes, ponds or swamps upstream from the disposal facility that can either store water and release it at a slow rate or fail and release large volumes of stored water at a high rate.

The runoff hydrograph at the point of interest will vary as a function of the intensity distribution of precipitation and the geometric shape and slope conditions of the watershed area. Inflow and outflow hydrographs for a typical impoundment are shown in Figure 9.3. The figure also shows the net inflow and volume of impoundment storage.

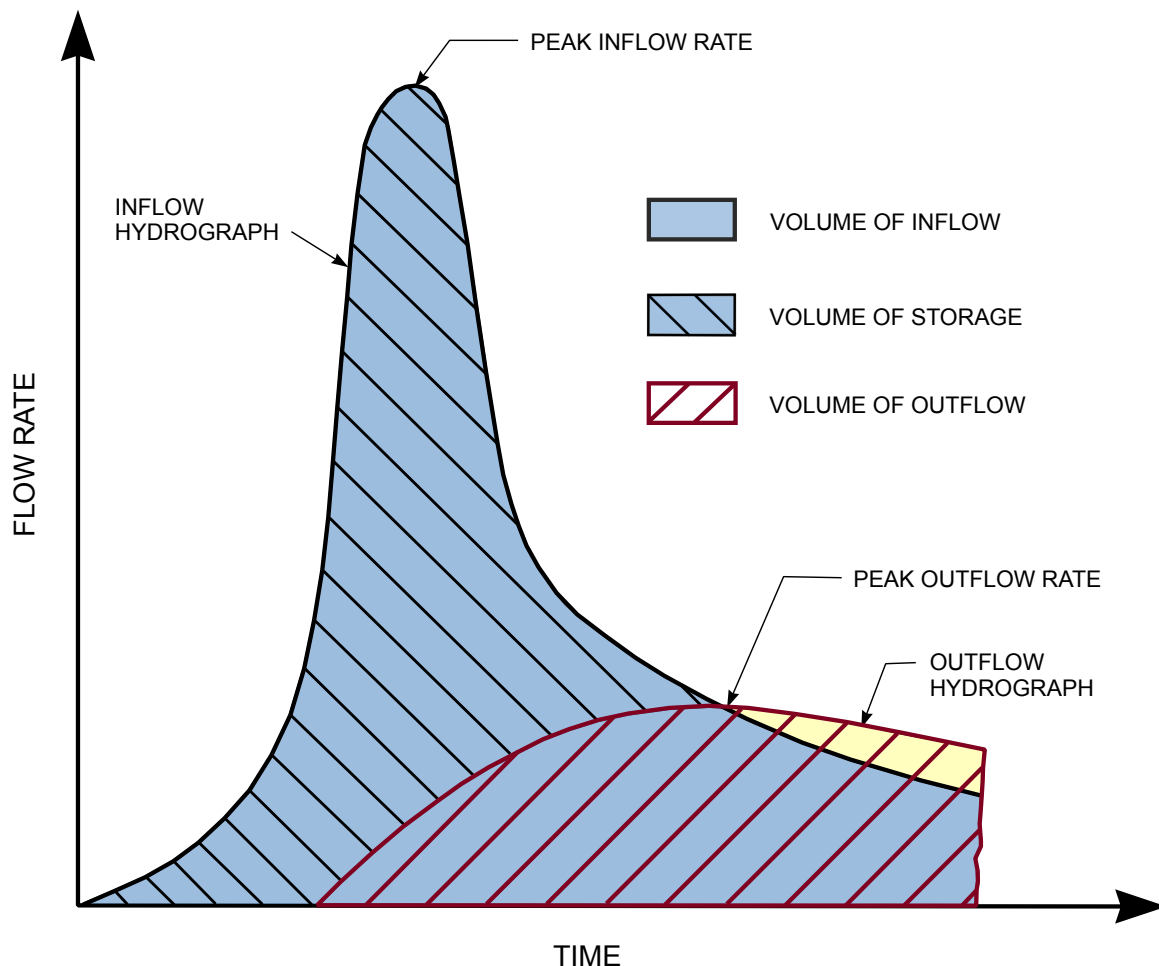

FIGURE 9.3 TYPICAL IMPOUNDMENT INFLOW AND OUTFLOW HYDROGRAPHS

9.2.3 Key Storage and Outflow Elements

The principal factors governing the storage capacity of a reservoir or impoundment are the physical dimensions of the embankment and ground surface and the current level of water/slurry. The outflow capacity is determined by the types and sizes of the hydraulic structures.

9.2.3.1 Impoundment Capacity

The storm storage capacity of an impoundment is the volume of runoff that can be temporarily retained during the applicable design storm. If a refuse disposal facility has minimal storage capacity, the outflow hydrograph will be about the same as the inflow hydrograph, and the hydraulic structures must be designed to transport the peak runoff rate. The primary benefit of impoundment storage is that the outflow rate can typically be reduced, permitting use of smaller hydraulic structures. An additional benefit is that the downstream flooding risk is not exacerbated by an increase in runoff from disturbed areas in the watershed. The potential difference in peak flow rates is illustrated by the inflow and outflow hydrographs shown in [Figure 9.3](#).

[Figure 9.4](#) shows a typical impoundment capacity curve relating storage volume to pool elevation. The figure also shows the relationship between reservoir surface area and pool elevation. Such curves are used to evaluate the storage conditions at any given pool elevation and are prepared as part of the design of an impounding structure ([Section 9.7](#)).

Two terms used to describe the limits of acceptable pool elevation are “surcharge” and “freeboard.” Surcharge is the vertical distance between the usual operations level of the impoundment and the maximum allowable water surface elevation. Normal freeboard is the vertical distance between the pool elevation and the top of the embankment at its lowest point (where the dam would begin to be overtopped). Design storm freeboard is the vertical distance between the maximum water surface elevation during the design storm and the top of the embankment. The minimum design storm freeboard is an impoundment design criterion and should be such that waves do not overtop the embankment crest during the design storm. Freeboard also serves to compensate for uncertainty in hydrologic parameters.

9.2.3.2 Decants, Principal Spillways and Auxiliary Spillways

Decants are conduits that extend through an embankment and discharge under controlled conditions at or beyond the embankment toe. As the term “decant” would imply, impoundment water typically enters the conduit by flowing over the top edge of the upstream end. At coal refuse disposal facilities, decants are generally not intended to discharge at high flow rates, but are designed to remove clarified process water, pass base stream flows or to drain the impoundment of stored water after a storm. However, a decant must be sufficiently large that stored water from the design storm can be drained within a reasonable period of time, so that the storage volume needed for a subsequent storm is available. Several types of decant systems are shown in [Figure 9.5](#).

Principal spillways are generally designed to control the discharge associated with large design storms, to limit discharges and associated impacts downstream, and to limit the frequency and duration of flow through the emergency (auxiliary) spillway. Principal spillways are most often associated with fresh water impoundments and sedimentation and treatment ponds, and state regulatory agencies typically provide specific design storm criteria that govern the size and capacity of these structures. In some coal refuse facility designs, the decant may also function as a principal spillway. Principal spillways are designed to: (1) release runoff at a controlled rate, (2) provide settling time for the removal of sediment or process water solids prior to discharge, (3) provide runoff detention, and (4) function as decants to control the impoundment operational pool level. Decant systems are generally not considered in design storm flood routing analyses for determining maximum impoundment pool level, as they do not have significant discharge capacity. If considered in the flood routing

analysis, the decant pipe should be of sufficient size that clogging is unlikely (typically, greater than 12 inches in diameter) and should be equipped with a properly designed trashrack.

Auxiliary (emergency) spillways are open channels generally used to discharge that portion of the runoff volume that cannot be stored in the impoundment or routed through the principal spillway. Auxiliary spillways typically are capable of discharging: (1) moderate flows from storms much smaller than the design storm (Section 9.5.1) with little or no damage or (2) large flows resulting from the design storm, where some localized damage may occur, but without the threat of failure of the entire impounding embankment. Typical auxiliary spillway systems are shown in Figure 9.6.

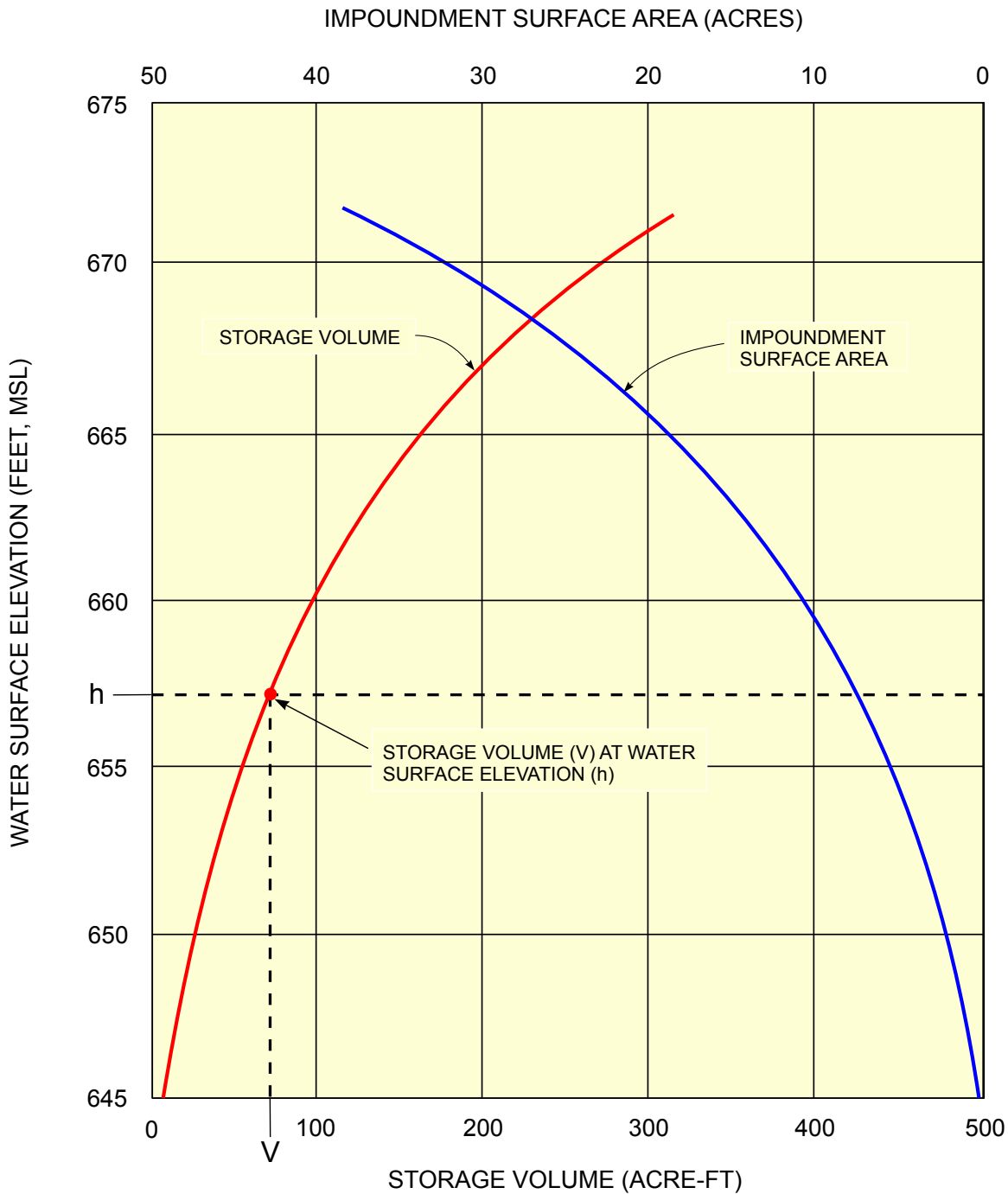
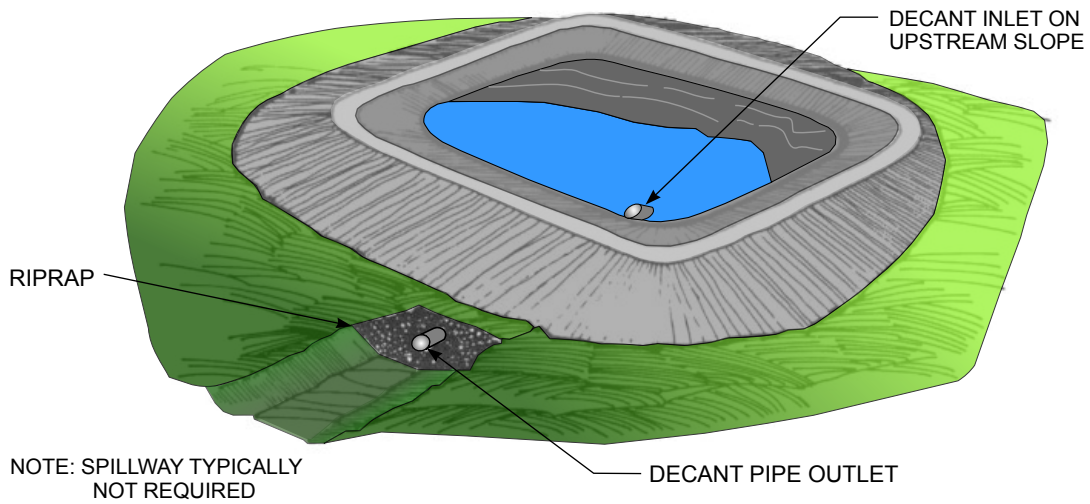
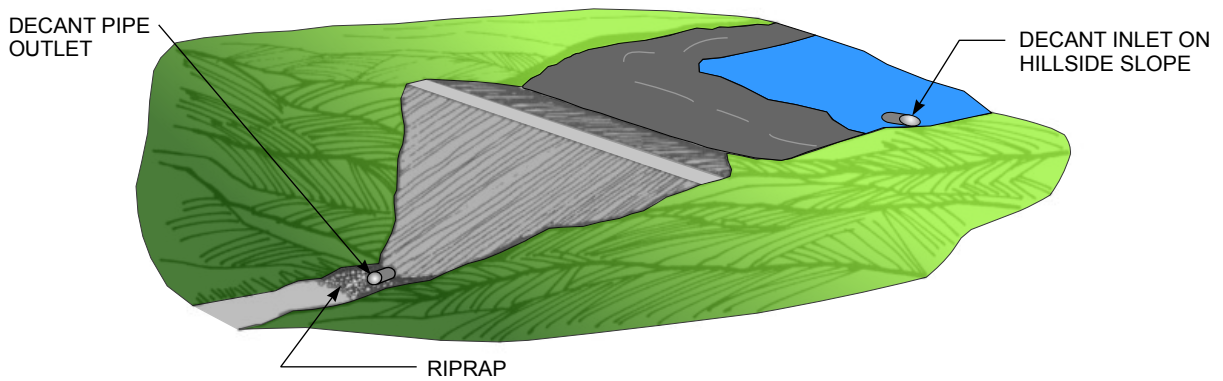

FIGURE 9.4 TYPICAL IMPOUNDMENT AREA AND STORAGE VOLUME CURVES



9.5a DECANT FOR DIKED IMPOUNDMENT



9.5b DECANT THROUGH REFUSE EMBANKMENT

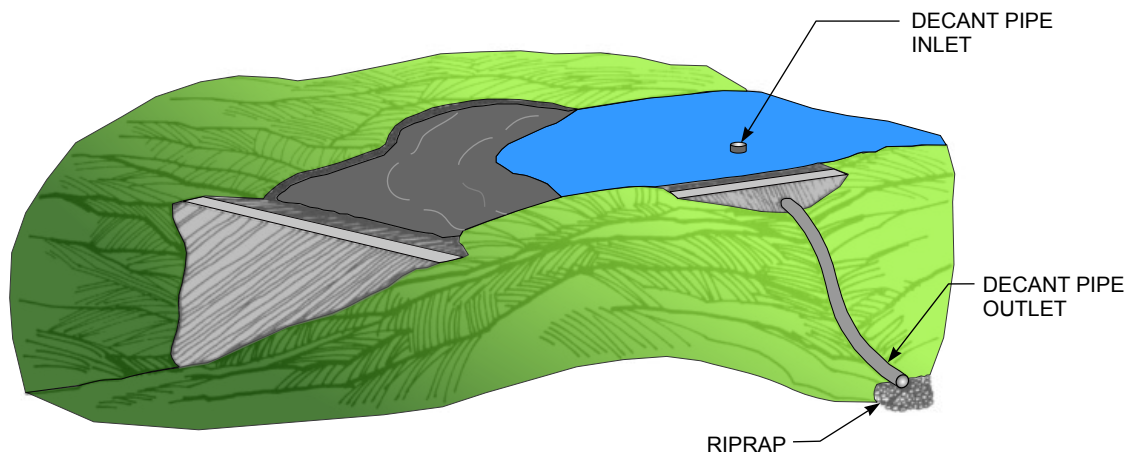

9.5c DECANT THROUGH SADDLE

FIGURE 9.5 TYPICAL DECANT SYSTEMS

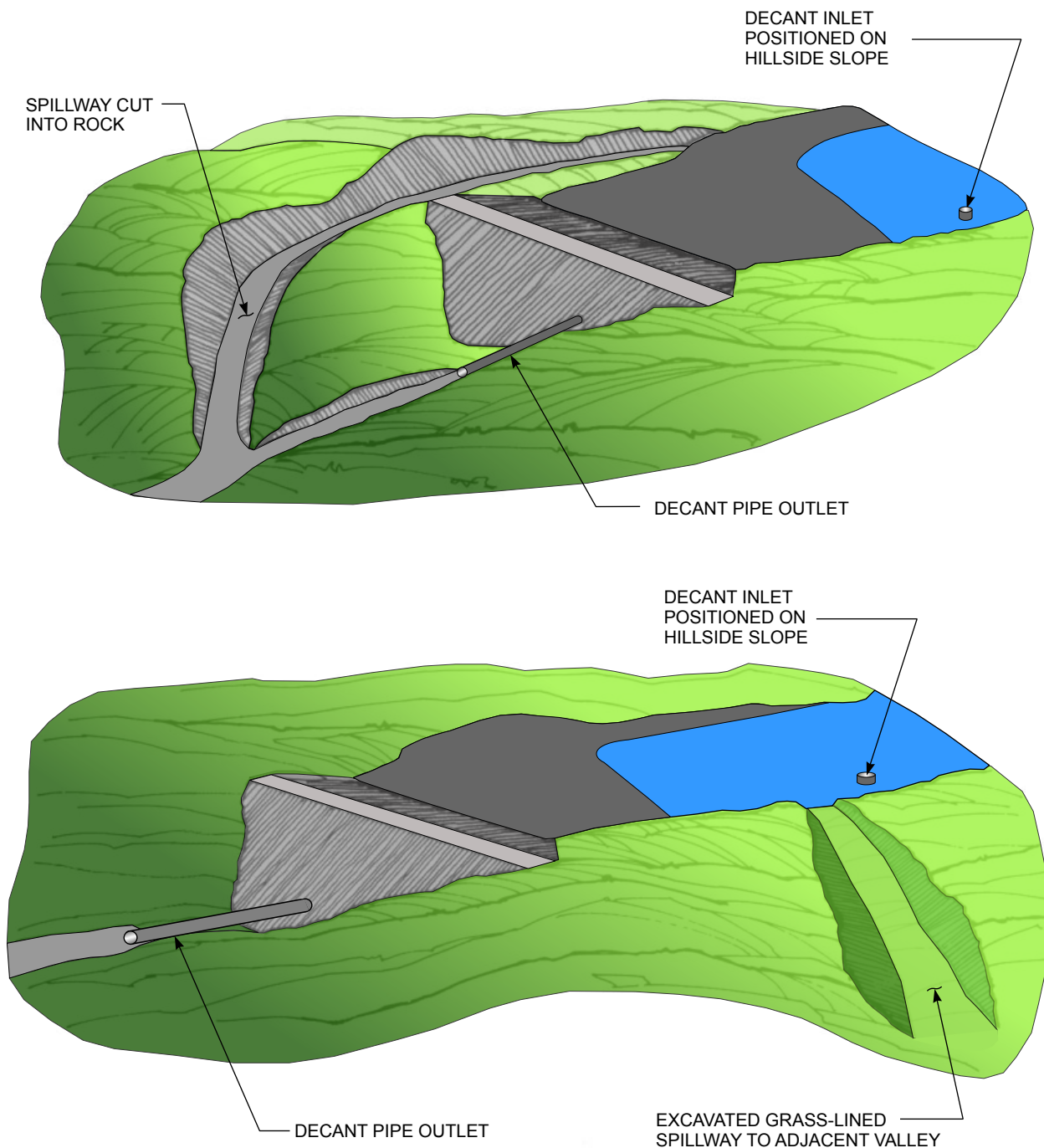

FIGURE 9.6 TYPICAL DECANT AND SPILLWAY SYSTEMS

The design of auxiliary spillways, principal spillways and decants normally requires evaluation of three basic components: the inlet, the transport section and the outlet. Key processes in the design of these systems include:

- Determining which component controls the outflow rate for various flow conditions.
- Sizing each component to function properly for the anticipated range of flow conditions.
- Specifying materials for each component that will not erode excessively under the anticipated flow velocities.

- Designing inlet or transport sections that will not become clogged or otherwise fail, causing major downstream damage or failure of the impounding embankment.
- Arranging the outlet location so that the release of water does not lead to failure of the impoundment embankment or major downstream damage.

The design of outflow systems is further discussed in [Section 9.7](#).

9.3 GENERAL CONSIDERATIONS FOR COAL REFUSE DISPOSAL FACILITIES

9.3.1 Special Characteristics

Table 9.3 lists characteristics that distinguish the design of typical coal refuse disposal facilities from many other structures with appurtenant hydraulic structures. In addition to the special characteristics indicated in Table 9.3, the hydrologic and hydraulic design of coal refuse disposal facilities is also governed by the considerations discussed in the following sections.

9.3.2 Site Conditions

Site selection impacts the cost and difficulty in providing adequate hydraulic appurtenant structures for use during the disposal period and subsequent abandonment of a coal refuse disposal facility. Based upon hydrologic and hydraulic considerations, the best site will almost always have the smallest possible upstream watershed. In some cases, however, hydrologic/hydraulic considerations are secondary to preparation plant location and materials handling requirements. Even if this appears to be the case, the designer should evaluate the needed hydraulic structures considering downstream hazard potential, environmental control and construction costs prior to finalizing the location for a disposal facility. Large initial costs associated with the construction of hydraulic structures may be justified if this allows materials transportation costs to be lowered.

TABLE 9.3 FACILITY CHARACTERISTICS INFLUENCING HYDRAULIC SYSTEM DESIGN

Characteristic	Significance In Design
The facility is designed for disposing coal refuse, with active operations taking place for an associated period of time, and not to collect water for flood prevention, water supply, power, or recreation.	Greater flexibility in choosing location, configuration and construction sequence for appurtenant hydraulic structures.
The facility covers a large area, with the gradient or drainage slope primarily in one direction.	Providing diversion facilities not subject to localized failures or controlled overtopping during large storms is often not economically practical.
The placement of refuse occurs over many years, during which time the facility configuration is constantly changing.	Hydraulic systems must be designed so that they can be expanded or decommissioned and replaced as the facility grows.
The growth rate of the facility is estimated based upon projected quantities of refuse production.	Actual quantities must be evaluated periodically to determine if the rate of construction is adequate.
Water passing over or through the coal refuse can be destructive or environmentally unacceptable.	Proper design requires that potentially adverse environmental effects (e.g., corrosion of construction materials), and the cost of water collection and treatment, be considered in the evaluation of alternative hydraulic systems.
When placement of refuse is completed, the facility typically has no continuing utility, and the hydraulic systems are decommissioned, the impounding capability is eliminated, and the site is abandoned in accordance with mine reclamation requirements.	The sequence of constructing hydraulic systems must provide an arrangement that will function until decommissioning at a specified future date. Planning must allow for the possibility that decommissioning, elimination of impounding capability, and abandonment may be required for a configuration either larger or smaller than originally anticipated.

The site conditions described in the following sections may affect decisions related to the selection and design of facility hydraulic structures.

9.3.2.1 Topography

The importance of topography on the geotechnical aspects of site selection and disposal facility configuration is discussed in detail in [Section 6.2.2.1](#). As discussed in this section, the significance of topography is generally limited to the planning, design and construction of hydraulic conveyance structures.

9.3.2.1.1 Steep Terrain

In areas of steep and rugged terrain, many disposal facilities must necessarily be located in valleys formed by small streams. Two very significant problems may be encountered with respect to placing diversion ditches, spillways and conveyance channels in these areas:

- Channels cut into the side of the valley will require the excavation of large amounts of material, as illustrated in [Figure 9.7a](#). With increased channel width, the cut becomes more extensive and the slope of the cut must often be decreased to achieve stability. These conditions combine to increase excavation quantities and costs disproportionately to the flow capacity gained.
- The potential for sloughing of overburden soil or weathered rock into the channel, thus restricting its flow capacity, is increased, as illustrated in [Figure 9.7b](#). Major sloughing will often occur during a heavy rainstorm when a large flow capacity is desired. The possibility of main spillway channels becoming obstructed by sloughing must be considered in the geotechnical analysis and design of the cut slope.

Diversion ditches for non-impounding coal refuse embankments are designed based on the design storm (100-year-recurrence-interval storm). For impounding coal refuse facilities with more extreme design storms such as the Probable Maximum Precipitation (PMP), it is usually not feasible to design perimeter diversion ditches large enough to pass the maximum flow. While diversion ditches for impounding facilities still perform an important function, the hydraulic design of the impoundment generally is based on the assumption that during large floods the diversion ditches will be overtopped and the resulting overflow will enter the impoundment. However, such overtopping should not be permitted to occur if flows in excess of the diversion ditch design storm could cause erosion of the dam and spillway.

Although there are undesirable aspects to cutting channels into steep slopes, there may also be significant advantages. Bedrock is normally found near the surface in rugged terrain. Thus, channels cut in such areas will often be resistant to erosion without special protection. A channel should be located where its base will be on the most resistant material. If possible, channels should be constructed in sound rock, particularly where flow velocities will be erosive and where failure of the channel would create an unsafe general condition or large repair costs. Another advantage that may be realized from cutting channels into such slopes is the concurrent production of borrow materials suitable for use as resistant drainage material.

9.3.2.1.2 Gently Sloping Terrain

In gently sloping terrain, the disadvantages associated with hillside channel excavation are not as pronounced as in steep terrain. As shown in [Figure 9.8a](#), the volume of excavation is a nearly linear function of channel width. In addition, achieving stability of the uphill cut slope is not as difficult as for channels cut into steep hillsides. However, as illustrated in [Figure 9.8b](#), these areas often do not have rock near the surface. Therefore, the channels are more susceptible to erosion unless flow

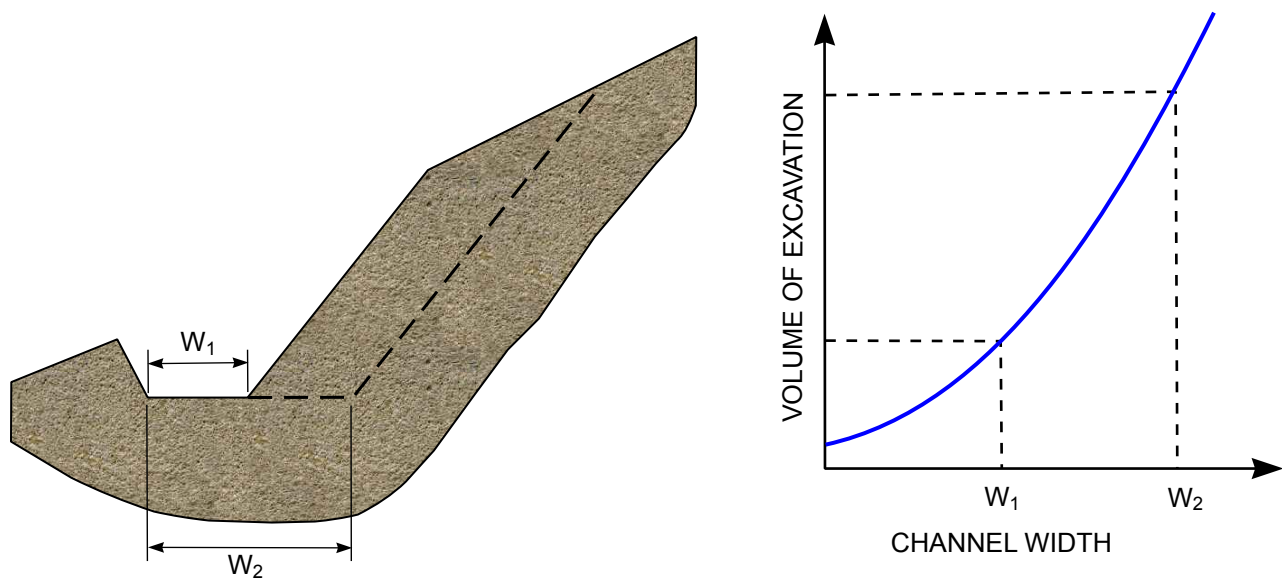

9.7a EXCAVATION VOLUME VS. CHANNEL WIDTH

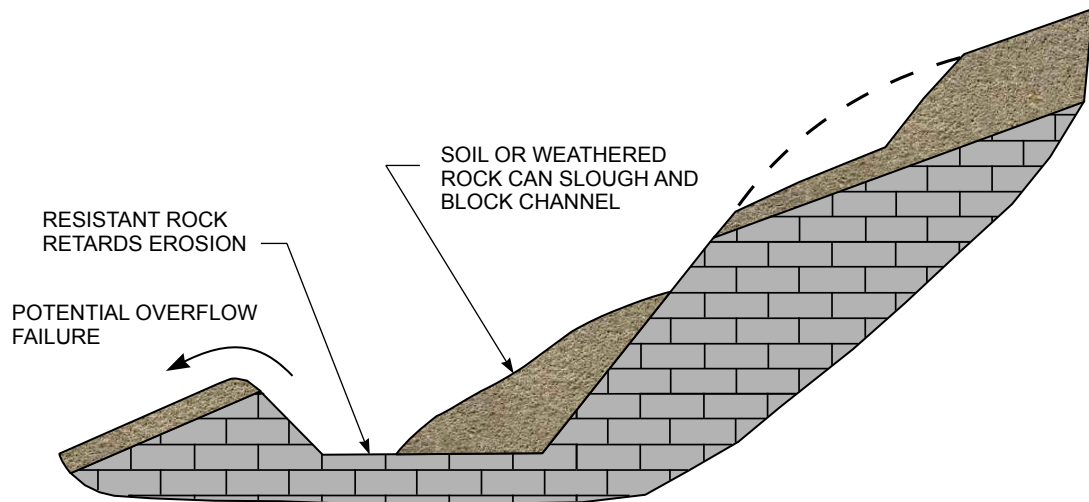

9.7b CHANNEL EROSION AND OVERBURDEN SLOUGHING

FIGURE 9.7 CHANNEL CONSTRUCTION IN MODERATELY AND STEEPLY SLOPING TERRAIN

velocity can be kept low or some type of stabilization system (e.g., channel lining) is provided. A key to economical design in this case is to minimize the length of channel sections where flow velocities exceed the natural erosion resistance of the channel.

9.3.2.1.3 Effects of Slope on Facility Staging

The combination of site topography and the constantly increasing size of coal refuse disposal facilities often creates design problems not normally encountered with other water-impounding facilities. For example, the previously mentioned difficulties involved in excavating wide auxiliary spillway channels in steep slopes are multiplied when the design requires that multiple auxiliary spillway channels be excavated as the height of the embankment is increased in subsequent stages. Problems

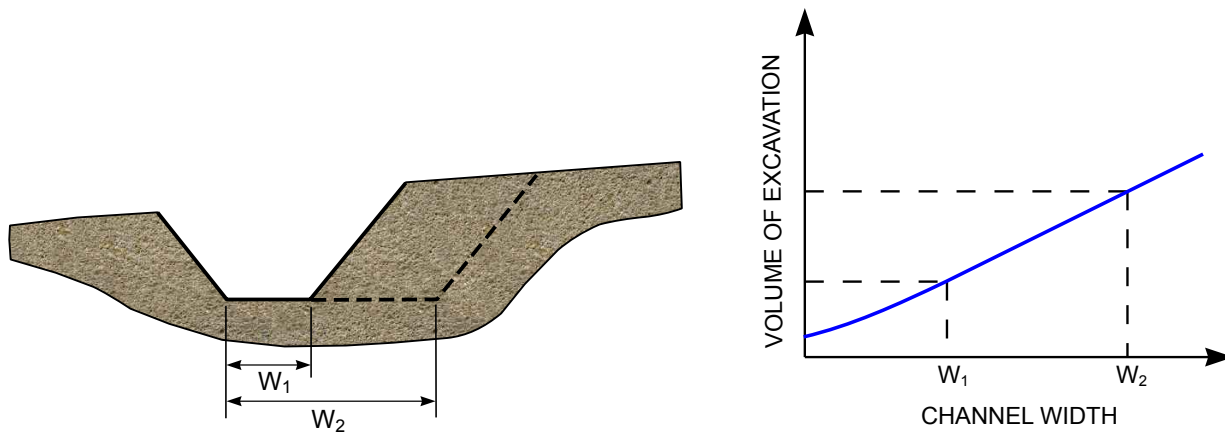

9.8a EXCAVATION VOLUME VS. CHANNEL WIDTH

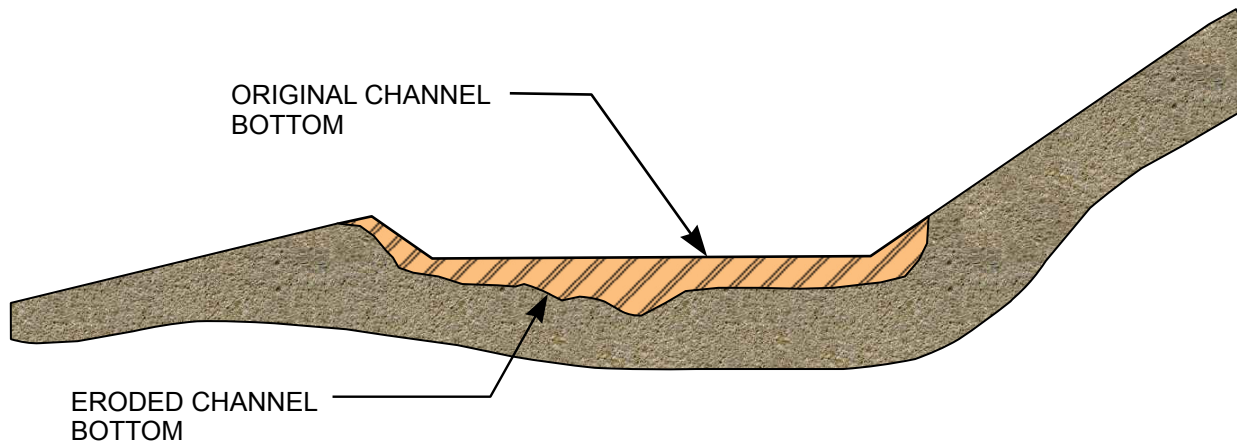

9.8b CHANNEL EROSION

FIGURE 9.8 CHANNEL CONSTRUCTION IN GENTLY SLOPING TERRAIN

can also occur when it becomes necessary to tie an embankment into an excavated rock face, as opposed to the original soil cover on the natural slope. Tying the embankment material into the steep and broken rock increases the potential for future problems related to seepage, leakage and embankment stability.

For cases where multiple auxiliary spillways are required with construction of succeeding stages, the designer may wish to consider a series of cascading spillways. A new embankment stage with its associated spillway channel can be configured to extend a sufficient distance downstream to allow the outflow to drop into the spillway channel of the preceding stage with the addition of a plunge pool. For such configurations, the hydraulic design of the channels and plunge pool and the erosion resistance of the rock must be carefully evaluated.

In some cases, the topography may permit an open-channel spillway to be located away from the embankment, such as through a saddle in a ridgeline, so that the flow is discharged into an adjacent watershed, as shown in [Figure 9.6](#). This arrangement can be beneficial in that potential issues associated with flow escaping from the spillway channel and adversely affecting the downstream face of the embankment are avoided.

9.3.2.2 Weather and Climate

Weather and climatic conditions should be considered as part of the planning associated with the design and construction of hydraulic structures. Specific examples include:

- In most coal regions of the United States, construction of channels, ditches, concrete spillways and decant systems should be scheduled to the extent possible during normal construction seasons and should be avoided in winter, when freezing conditions and snowfall may interrupt construction. Accordingly, the staging of any disposal facility should be planned so that there is adequate flexibility to allow extensions, replacement or modification to hydraulic systems during favorable weather even though coal refuse is handled and disposed on a year-round basis.
- Many western coal fields are in arid or semi-arid climates where the growth of vegetation is a very slow process. In these areas, using vegetation as a means of erosion protection in excavated channels may not be practical.

9.3.2.3 Geology

Normally, geologic conditions do not change drastically within a small geographic area, and thus they generally do not directly affect disposal facility site selection alternatives. However, soil and rock conditions at a site are always important to the design of hydraulic structures and often are the deciding factor in choosing among several hydraulic system alternatives with similar cost and utility characteristics. The following are important geologic and geotechnical factors that must be considered in design:

- If excavated channels in steep slopes are being considered, the designer should evaluate the stability of the cut slopes. If excessive costs will be required to achieve stability, either by benching or by constructing retaining systems, an alternative system may be more cost effective.
- If an excavated channel is to be located along a hillside, it should have a sufficient capacity that overtopping or discharge that could cause cascading water to flow onto a critical portion of the embankment does not occur. If a bend in the channel is required, the effects of flow, erosion, and water superelevation caused by the change of direction should be carefully evaluated. The outlet end of a spillway channel should be located sufficiently far downstream that the discharge will not erode the downstream face of the embankment.
- Channels should be designed to resist potential erosion effects, so that post-construction stabilization is not required.
- If hydraulic structures are to be constructed in or over soft soils or soft coal refuse, the amount of settlement that could occur should be estimated in order to determine whether special construction will be required. Similar considerations may arise in situations where differential settlement may occur, such as where hydraulic structures are constructed across rock abutments and onto fill materials. This is especially important for conduits through an embankment. Where possible, such conduits should be founded on and properly bedded in firm materials that will not settle significantly. Where settlement is unavoidable, the initial slope, camber, joints and conduit material should be selected such that anticipated settlements can be accommodated without damage to the system.

The effect of geologic conditions on runoff during storms is discussed in Section 9.6.1.

9.3.3 Construction Materials

The selection of construction materials for hydraulic structures should account for the following:

- The potential for corrosion of construction material is high at many coal refuse disposal facilities because of the chemical characteristics of water seeping through refuse materials. Choosing corrosion-resistant materials with higher initial cost may be far less expensive over the long term than repairing a deteriorated structure several years after its original installation, especially if the structure will be buried under many feet of refuse.
- Any conduit or structure beneath or within an embankment should be designed for the external pressure of the maximum potential height of the embankment above it and for deformations that may result from embankment construction.
- Channel lining material should be selected to be resistant to the maximum anticipated flow velocities with provisions for drainage and resistance to uplift pressures.
- Filter criteria for all materials used in the embankment and appurtenant structure construction should be evaluated so that the potential for erosion and piping within the embankment or loss of structural support and/or failure of the hydraulic conveyance structures is minimized.

9.4 DESIGN CONSIDERATIONS FOR DISPOSAL FACILITY EMBANKMENT TYPES

In addition to the general design considerations discussed in Chapter 5, there are specific hydrologic and hydraulic design considerations for each type of coal refuse disposal facility embankment. The following discussion of facility-dependent hydrologic and hydraulic design considerations is a general summary of the most common considerations for each type of disposal facility.

Some of the primary hydraulic system functions common to all refuse disposal facilities are listed below. The type and configuration of the coal refuse disposal facility determines the significance of each function.

- Collection of runoff from the watershed above the embankment and from the surface of the embankment.
- Control, conveyance and discharge of collected water to a downstream location.
- Control of the embankment slope utilizing benches at 50-foot or lower vertical intervals to reduce potential erosion.
- Erosion protection of the embankment surface during initial, interim and reclamation stages, especially along the embankment face.
- Protection of streams or wetlands from encroachment or other potential environmental impacts that may require mitigation.
- Protection of downstream water quality from sediment-laden runoff, leachate from internal drain collection systems, or collected seepage.

The specific impact of the above hydrologic and hydraulic design considerations is discussed in the following sections. While typical figures are presented to assist in recognizing specific conditions, they do not depict all design situations.

9.4.1 Non-Impounding Embankments

Non-impounding embankments are used for the disposal of coarse, combined, and dewatered fine coal refuse. A non-impounding coal refuse disposal facility is designed such that no fine coal refuse slurry, process water or direct or indirect runoff can accumulate within or upstream of the disposal

facility limits. General types of non-impounding coal refuse embankments include valley, ridge, side-hill and heaped fills.

9.4.1.1 Valley-Fill Embankments

Valley-fill refuse embankments, as illustrated in Figure 9.9, are often constructed by starting disposal at the upper end of a valley and extending the embankment in stages down the valley in such a manner that an impoundment is never created. Often these types of embankments are located in large valleys so that large refuse disposal volumes can be placed. The potential runoff in such valleys during a large storm event can be high, and to prevent excessive erosion large diversion channels may be needed. A key design objective associated with the collection of watershed and embankment surface runoff and the discharge of the collected water at a downstream point is to provide the optimum balance between channel cross section and slope, thereby minimizing the cost associated with channel erosion protection.

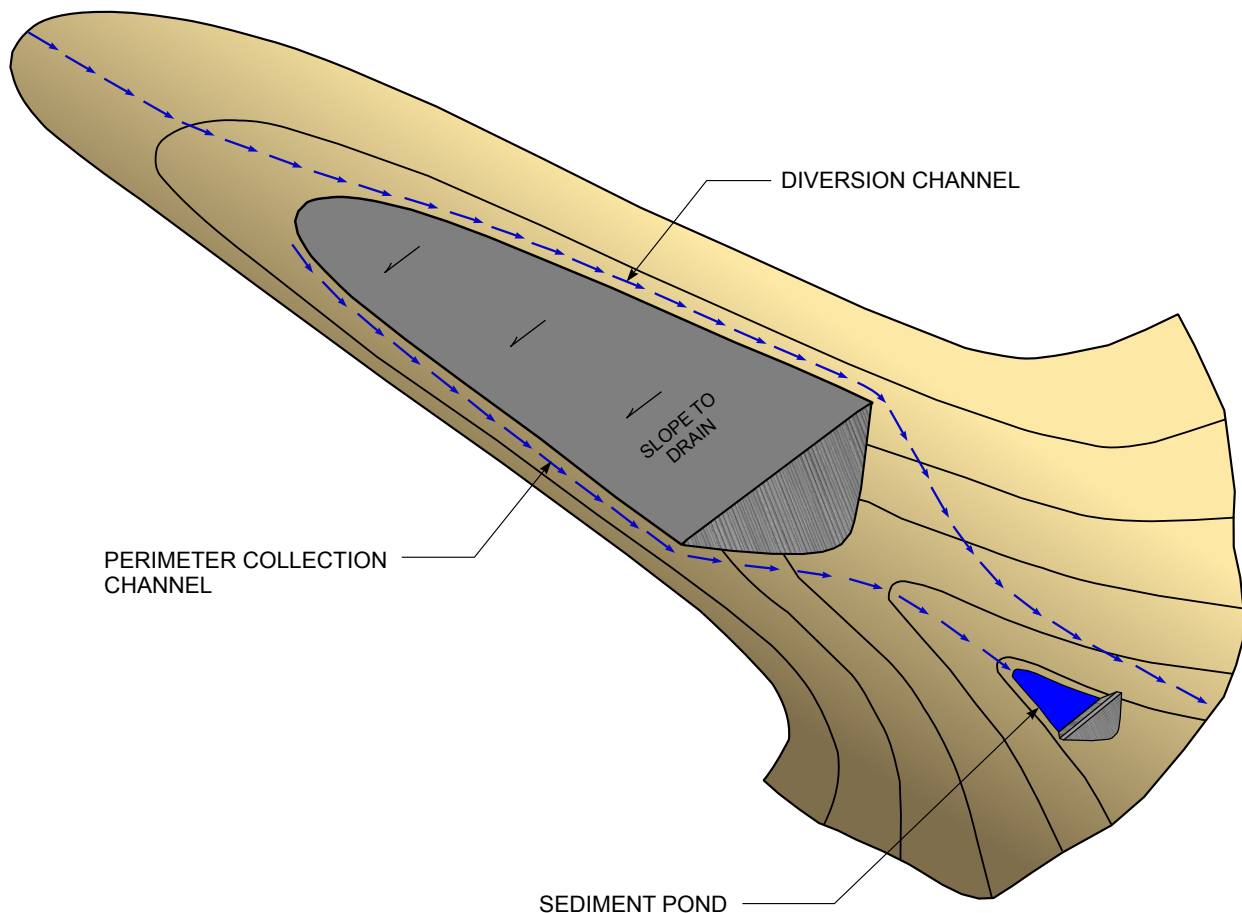

FIGURE 9.9 DRAINAGE CONTROL FOR VALLEY-FILL, NON-IMPOUNDING EMBANKMENT

The most difficult portion of the channel design is along the embankment face at the interface of the coal refuse and the natural ground surface where the steep slope typically results in high velocities. If practical, the channels should be extended along the valley wall, within natural soil and rock, beyond the limits of the coal refuse embankment to discharge beyond the embankment toe. If such an extension is not practical, it is normally necessary to construct a lined or otherwise protected channel at the interface of the refuse embankment and valley wall to carry the runoff safely to the valley floor. The long diversion/collection ditches along the crest of the disposal facility should be designed with a base width and slope that allows use of grass-lined channel sections, if possible.

The mixture of runoff, leachate and seepage may require treatment prior to discharge to the receiving waterway. Such treatment could entail construction of sedimentation ponds and also ponds for chemical treatment. Sufficient area for construction of the sedimentation/treatment ponds should be allocated. However, these facilities should be located above the level of the 100-year floodplain associated with the receiving stream and not in a position where they could be affected by normal stream flows.

9.4.1.2 Side-Hill, Ridge and Heaped Embankments

Side-hill, ridge and heaped non-impounding embankments have design configuration considerations similar to those for valley-fill embankments. The upstream and perimeter watersheds are generally smaller than for a valley-fill embankment, but the steepness of the final embankment slopes and the water quality of the runoff and seepage result in similar hydrologic and hydraulic design considerations as for a non-impounding, valley-fill embankment. [Figure 9.10](#) shows drainage control for side-hill and heaped embankments.

Side-hill embankments are usually constructed in stages that extend progressively higher on a natural slope. Therefore temporary diversion ditches are needed for collecting and diverting runoff at intermediate stages when the embankment is not at full elevation. The channel dimensions, slope and required erosion protection should be designed to meet the final conveyance requirements and to provide economical erosion protection. The location of the toe of the embankment should lie outside the 100-year floodplain limits of nearby streams to minimize any potential encroachments, and sufficient area should be available for sediment/treatment pond construction.

Ridge embankments are generally in the upper reaches of a watershed and may resemble a side-hill embankment extending above and over a ridge line. The collection and conveyance of precipitation falling directly onto the embankment is the primary issue since there is typically little if any upstream watershed. This type of facility generally has a limited downstream area available for sedimentation control and chemical treatment, and the natural ground surface may slope away from the disposal facility in several directions and potentially into other watersheds. Therefore, multiple sedimentation ponds and pumping to a common point for treatment may be required.

Heaped embankments are generally located on flat terrain. The collection and conveyance of runoff is primarily related to conveying precipitation that falls directly onto the facility and diverting adjacent area runoff away from the facility. Collection ditches on benches and at the crest are typically gently sloping, and grass-lining can normally be used as the channel erosion control. Ditches conveying runoff from the crest or benches to the toe of the embankment are steeper than the collection channels and typically require a more durable lining material such as riprap, concrete or manufactured erosion protection material. Also, the outlet structure must be sufficiently oriented and properly designed to prevent erosion of the embankment toe. For high embankments, special consideration is required at the discharge points so that the energy of the high velocity flow is dissipated and/or the flow is directed away from the embankment in a manner that prevents erosion of the toe.

9.4.2 Slurry Cell Embankments

The hydrologic and hydraulic aspects of slurry cell embankment design must accommodate the volumetric sequencing of the slurry cells as well as the collection and conveyance of both runoff around the cells and direct runoff that accumulates within the slurry cells. Individual slurry cell design must meet structural and hydraulic design requirements, and construction must be controlled in such a manner that the slurry cells do not become a large interconnected impoundment. The slurry cell concept is based on limiting the total capacity of all open cells (and flowable material if present in closed cells) to a level that is consistent with a low-hazard-potential classification for the facility or does not meet the criteria for a regulated impoundment provided in 30 CFR § 77.216.

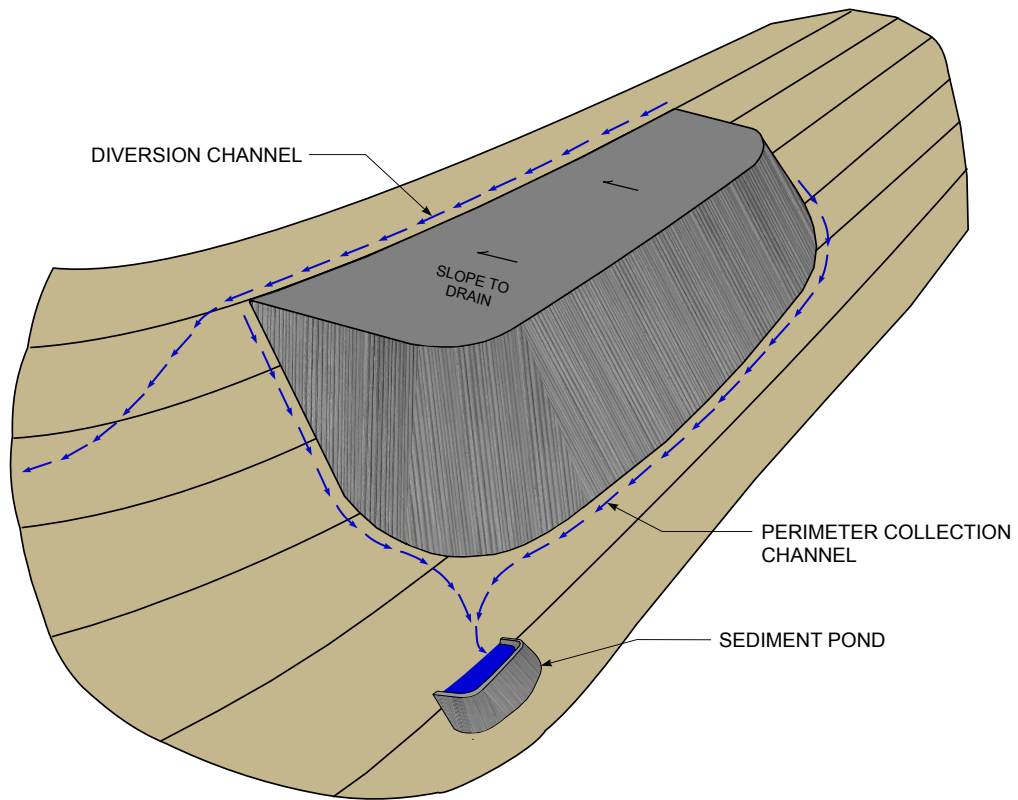

9.10a SIDE-HILL EMBANKMENT DRAINAGE CONTROL

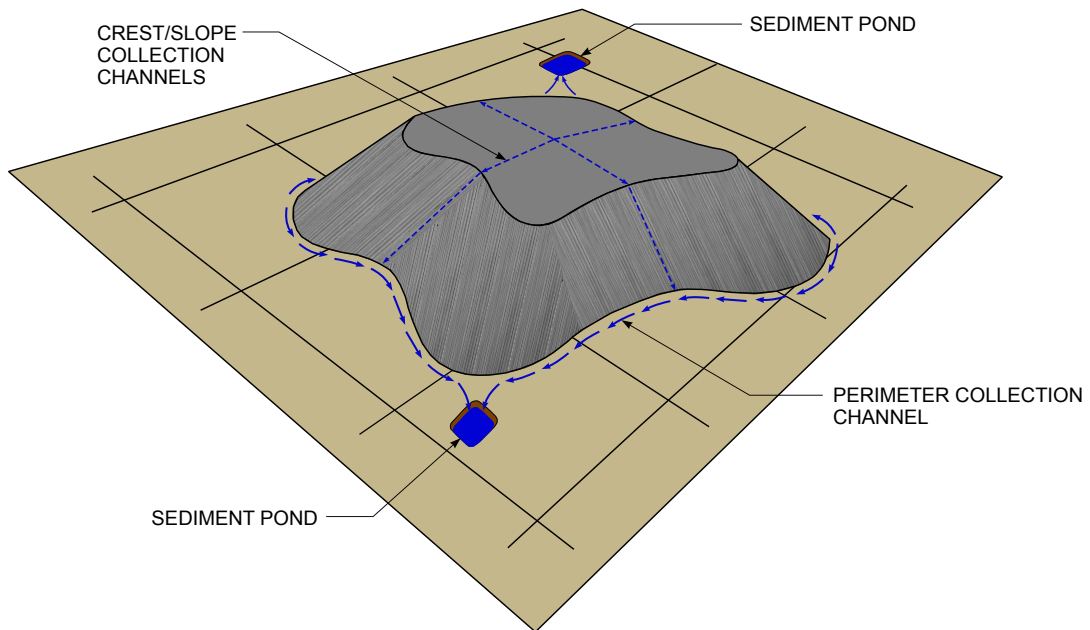

9.10b HEAPED EMBANKMENT DRAINAGE CONTROL

FIGURE 9.10 DRAINAGE CONTROL FOR SIDE-HILL AND HEAPED EMBANKMENTS

In order for a slurry cell embankment with multiple cells to not require an approved impoundment plan in accordance with the criteria in 30 CFR § 77.216, each individual cell must not exceed the 20-acre-foot size criterion. Furthermore, where the failure of one cell can result in the failure of another, or where slope failure can result in the release of water or slurry from multiple cells, the cumulative storage capacity of the affected cells must not exceed 20 acre-feet. In situations where multiple cells are operated or arranged such that they may interact and exceed the 20-acre-foot limit, the embankment should be classified as impounding and should be designed for the appropriate design storm based on its hazard classification. A critical consideration in determining the hazard classification for an impounding embankment is the flowability of the fine coal refuse. Generally, slurry cells work most effectively when the depth of fines in the cells is kept relatively shallow, preferably to five feet or less, such that after dewatering and capping the material is unlikely to be flowable. In instances where there is concern for draining of the fine coal refuse, the following guidance for assessing the flowability of fine coal refuse is suggested:

- Fine refuse is generally considered flowable for: (1) operating cells with active fine refuse disposal, (2) non-operating cells containing predominantly saturated, fine refuse deposits that have not been covered, and (3) covered cells with predominantly saturated fine refuse deposits characterized as very loose sand or very soft silt or clay.
- Fine refuse is generally considered non-flowable for: (1) non-operating cells with predominantly unsaturated, fine refuse deposits that have been covered and (2) covered cells with predominantly saturated fine refuse deposits characterized as medium dense sand or medium stiff silt or clay.
- Fine refuse should generally be considered flowable, unless additional testing and analysis demonstrates that it is non-flowable, for non-operating cells with predominantly saturated fine refuse deposits characterized as loose sand or soft silt or clay.

Michael et al. (2005) in an OSM report prepared a review of the flowability of impounded fine coal refuse that discusses recent work and ideas in the engineering profession.

The major hydrologic and hydraulic considerations for slurry cells are the collection, conveyance and discharge of runoff within the main diversion and perimeter ditches plus the discharge of direct runoff from individual slurry cells. As ditches are relocated and new cells are constructed at higher elevations, care should be taken so that the embankment is not advanced vertically to the extent that its impounding capacity exceeds the disposal plan criteria and affects hazard classification. Special consideration is required at the discharge points to control flow and prevent erosion of the embankment. The location of the toe of the embankment should lie above the 100-year floodplain limits of nearby streams in order to minimize the potential for encroachments, and sufficient area should be available for sediment/treatment pond construction. [Figure 9.11](#) shows drainage control measures for a typical slurry cell facility.

9.4.3 Slurry Impoundments

The primary hydrologic/hydraulic issue associated with slurry impoundment design is the continuous balancing of coarse coal refuse disposal, fine coal refuse slurry disposal and maintenance of storm water runoff storage/routing capacity. Direct runoff at a slurry impoundment is typically controlled by a decant system or principal spillway, although some disposal facilities also employ an auxiliary (or emergency) spillway. The operation and performance of these outlet works is integral to fine and coarse coal refuse disposal and the safe operation of the impoundment. To protect the impounding embankment from erosion, perimeter runoff control structures must also be incorporated into the design. The location of the toe of the embankment should lie outside the 100-year floodplain limits of

nearby streams to minimize any potential encroachments, and sufficient area should be available for sediment/treatment pond construction.

The type of coal refuse disposal facility configuration (e.g., cross-valley, diked or incised impoundment) is typically a function of topographic conditions in the vicinity of the coal mine. Frequently, a decant system and storage are used to control runoff and thus minimize costs associated with other types of outlet structures. However, this requires sufficient embankment materials to achieve the required storage and may not be feasible for large watersheds. Therefore, some impoundments with large watersheds have auxiliary (or emergency) spillways in combination with planned storage capacity and a decant system to control runoff from the design storm.

Regardless of the outlet structures chosen for various impoundment development stages, special consideration must also be given to the conditions that will exist when the site is no longer maintained as an impoundment. At that point, the impounding capacity must be eliminated by: (1) backfilling the impoundment (typically with coarse coal refuse), (2) excavating a channel through the embankment to the level of the backfilled stabilized fines, or (3) a combination of these methods, which is typically the most effective approach. The approach taken must include measures to prevent significant erosion.

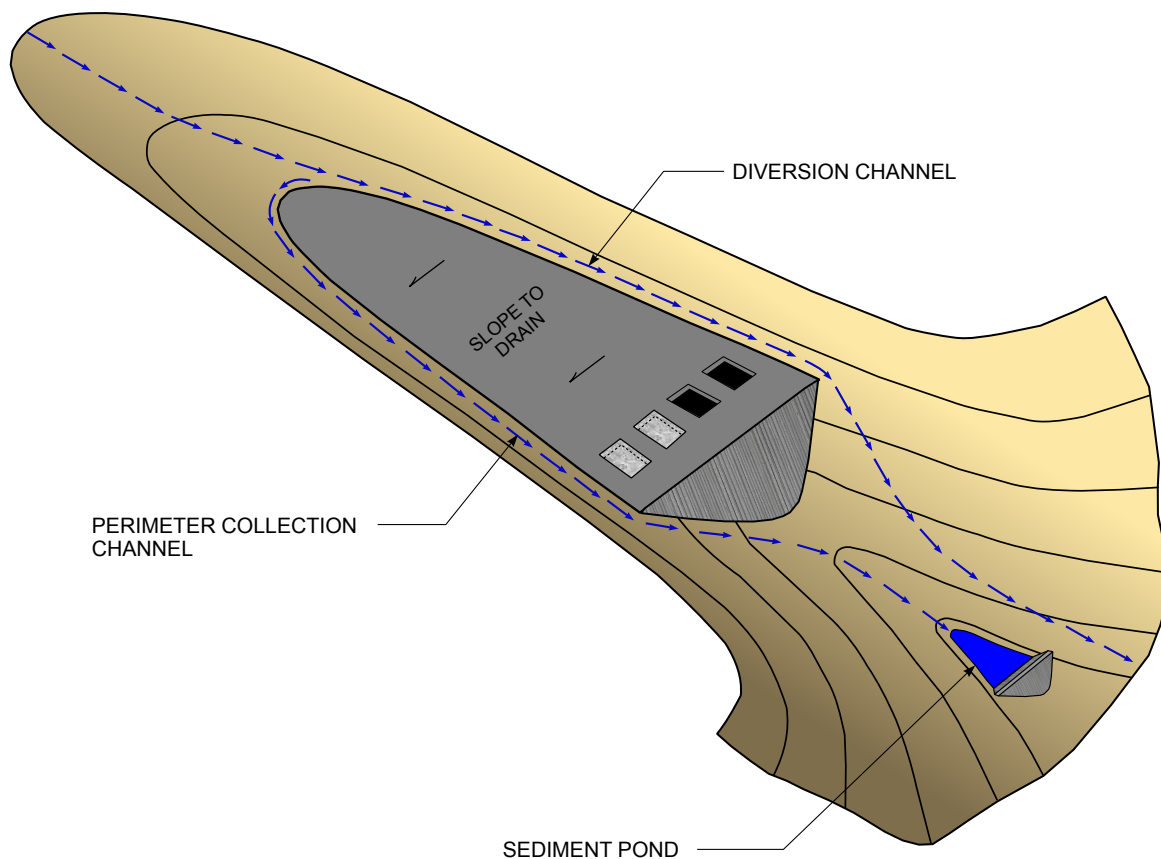

FIGURE 9.11 DRAINAGE CONTROL FOR SLURRY-CELL FACILITY

9.4.3.1 Cross-Valley Impoundment

A cross-valley impoundment typically consists of an embankment constructed primarily of coarse coal refuse that functions as a dam to impound a mixture of settled fine coal refuse, slurry, clarified water and runoff. The impoundment storage and outflow capacity determine the hydraulic structures needed for controlling runoff.

The most appropriate method for minimizing the spillway construction effort is to provide a very large surcharge capacity between the initial pond elevation and the initial embankment crest. A spillway can then be constructed at a significant height above the initial pond level, providing adequate surcharge capacity for a long operational period before the hydraulic system must be expanded. Coarse coal refuse typically provides the material for economically constructing this surcharge capacity. An extension of this approach would be to initially provide for total storage with no requirement for a spillway (although with this approach there must be provisions for drawing down the reservoir in response to consecutive or repeated storms).

Regardless of the percentage of runoff to be handled through reservoir storage, the design configuration must always accommodate the continual rise in the normal pool level due to the disposal of fine coal refuse slurry. Reduction in reservoir storage capacity due to upstream construction pushouts and stages must also be taken into account. A decant system allows the controlled discharge of surcharge runoff. It may also be used to evacuate clarified slurry water. Depending upon the configuration of the impoundment, an open-channel spillway may be needed to discharge runoff from larger storm events.

To protect the downstream face of the coal refuse embankment from erosion, perimeter runoff that is intercepted by embankment bench gutters, road gutters and collection and diversion ditches must be controlled and routed to a sediment/treatment pond. The conveyance structure configuration and erosion protection should be designed to be appropriate for all stages of development, including reclamation. Some typical drainage control measures for a cross-valley impoundment are illustrated in [Figure 9.12](#).

9.4.3.2 Diked Impoundment

Diked impoundments have design constraints similar to those for cross-valley impoundments. If a facility is completely diked such that there is no upstream watershed, the required impoundment surcharge capacity is minimized, and the primary factor affecting the impoundment storage capacity is the production of fine coal refuse and clarification of slurry. Typically, a decant system and/or principal spillway are adequate for control of runoff. If an auxiliary spillway is employed, the channel section through the embankment requires erosion-resistant linings.

Perimeter ditches and bench gutters tend to be of substantial length and should be designed with sufficient slope to adequately convey runoff to sedimentation ponds and to drain effectively without low areas. Where ditches traverse embankment slopes, they should be provided with erosion-resistant linings. [Figure 9.13](#) shows drainage control measures implemented for a typical diked impoundment.

9.4.3.3 Incised Impoundment

Incised impoundments, or ponds, are used for the disposal of fine coal refuse. They are typically small and often used for temporary or emergency disposal. The hydrologic and hydraulic considerations associated with cross-valley impoundments and diked impoundments are generally not major issues for incised ponds because of the reduced risk of catastrophic failure. There are three principal design considerations: (1) an outlet structure to decant or control the release of clarified process water, (2) diversion to convey adjacent area runoff around the incised pond, and (3) flooding potential, if the incised pond is located close to or within floodplain limits.

9.4.4 Other Impounding Structures

Coal mining operations generally include sedimentation, treatment and fresh water ponds. The capacity of each of these structures is a function of the intended use. Sedimentation or treatment

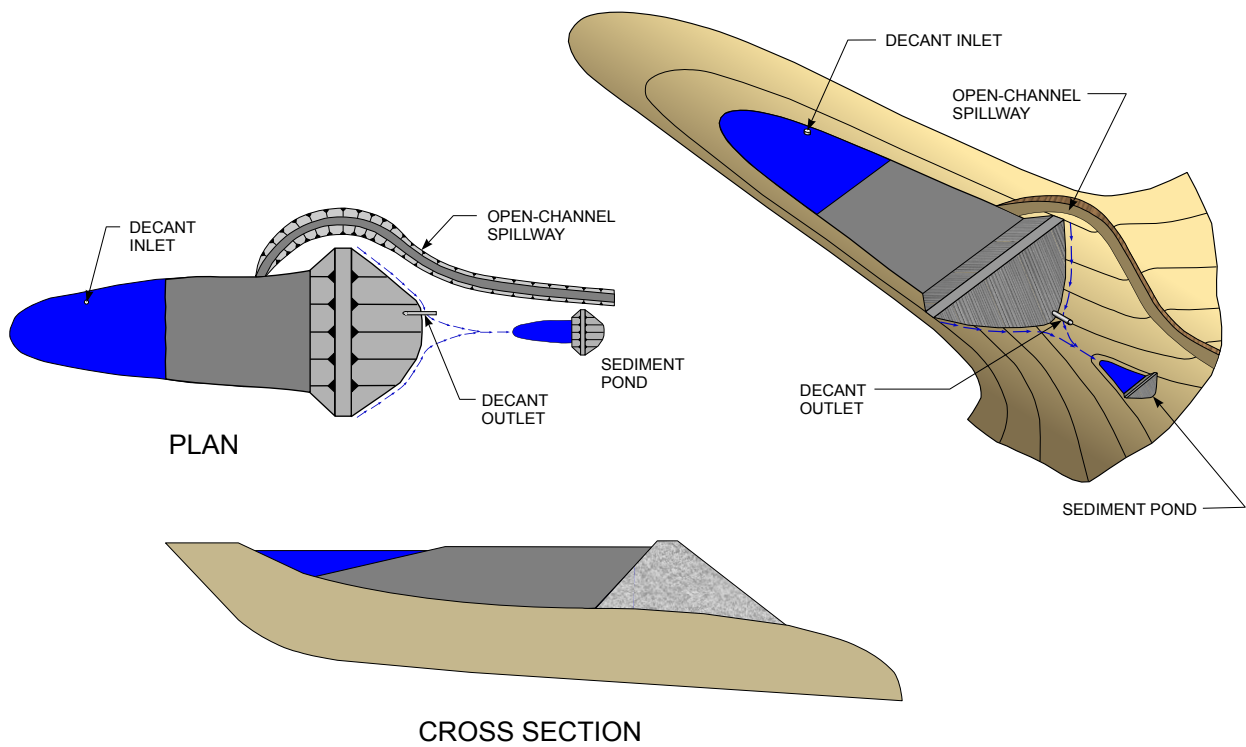

9.12a CROSS-VALLEY IMPOUNDMENT WITH OPEN-CHANNEL SPILLWAY

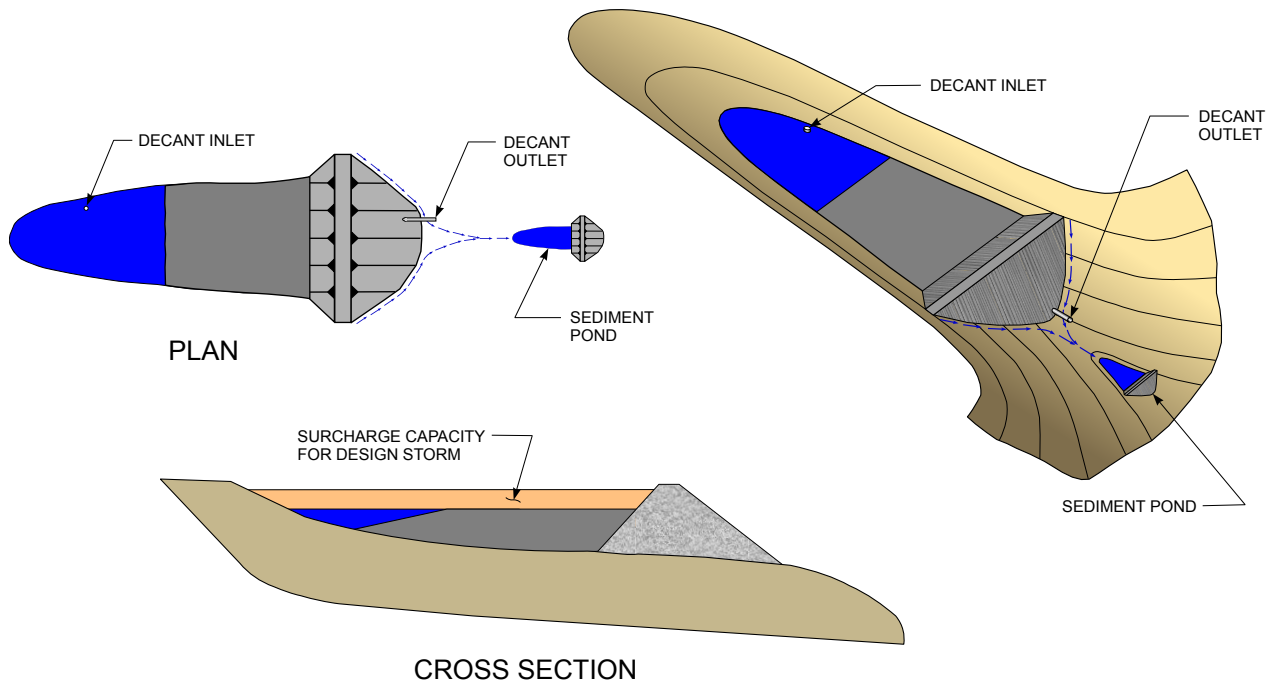

9.12b CROSS-VALLEY IMPOUNDMENT WITH DESIGN STORM STORAGE AND WITHOUT OPEN-CHANNEL SPILLWAY

FIGURE 9.12 DRAINAGE CONTROL FOR CROSS-VALLEY IMPOUNDMENT

pond capacity is related to the ability of the structure to remove constituents such as suspended solids or metals that exceed effluent limitations. Fresh water ponds must have the reservoir capacity to meet the coal processing and other mining requirements. The size (height and reservoir storage capacity) and downstream impacts of failure of these structures determines the hazard potential and, as a consequence, the design criteria.

9.4.4.1 Sedimentation and Treatment Ponds

Sedimentation ponds and treatment ponds are typically located beyond the toe of coal refuse disposal facilities or below mining-disturbed land, so that they can receive gravity inflow. The sediment and settling capacity of these structures is typically specified in state erosion and sedimentation control guidelines and effluent limitations. Similarly, treatment pond size is dependent on the pond's ability to treat/remove and discharge acceptable water quality. Pond principal and auxiliary spillway structures should be designed to discharge water at a rate consistent with design storm criteria and state regulatory requirements. A primary consideration is the maximum anticipated runoff associated with the embankment staging based on watershed size, hydrologic considerations, and the surcharge storage capacity, which is significantly less than the gross impoundment capacity. For sediment ponds, as storage capacity drops, the principal and auxiliary spillways must be able to handle increased discharges. For ponds located below coal refuse disposal facilities, pond size is a function of the size of and outflow from the upstream structure. The inflow may be only surface runoff from the face of a coal refuse embankment, but it more typically includes decant water discharges, internal drain system discharges from the coal refuse disposal facility, and other adjacent area runoff.

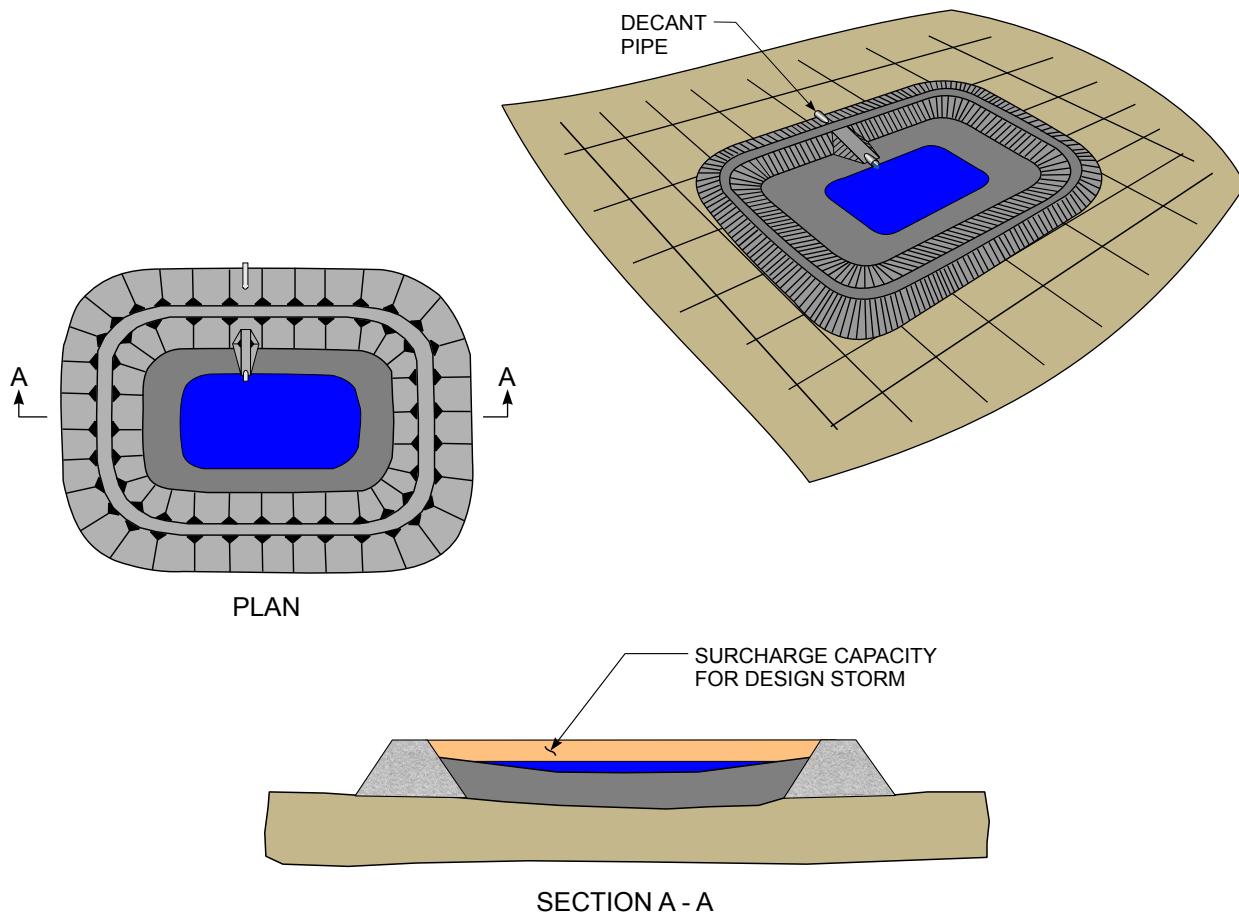

FIGURE 9.13 DRAINAGE CONTROL FOR DIKED IMPOUNDMENT

9.4.4.2 Fresh Water Impoundments

Fresh water impoundment capacity is determined by the mine and mine processing plant requirements. Fresh water impoundment capacities are generally large, and these impoundments are often regulated as high-hazard-potential structures. Fresh water impoundments should be designed and constructed according to accepted criteria for conventional dams. Outlet structures for these impoundments generally include both principal and auxiliary spillways.

9.5 DESIGN STORM CRITERIA

The quantity and distribution of runoff during a design storm for a coal refuse disposal facility site largely controls the design of hydraulic appurtenant structures. This section discusses design storm criteria in terms of the recurrence interval of the precipitation and the magnitude of precipitation measured in inches of rainfall. [Section 9.6](#) discusses methods for converting design precipitation to design runoff volume and peak flow rates.

The appropriate design storm for a coal refuse disposal facility depends primarily on the consequences of the uncontrolled release of impounded material due to failure or faulty operation of the facility. Other factors that may affect the design storm include the facility configuration and size, type of hydraulic systems and operational period. Portions of the total hydraulic system, such as drainage culverts, ditches and some diversion channels will not generally create potentially hazardous conditions, so other design criteria can be selected for these structures. This situation is most likely to occur at non-impounding disposal facilities and at the perimeter of and appurtenant structures associated with impounding facilities.

Criteria for selecting a design storm for the operational period of an impounding facility are presented in [Section 9.5.1](#). Design storms that are applicable for short-term conditions are discussed in [Section 9.5.2](#). Design storm criteria for minor site drainage conveyance structures are presented in [Section 9.5.3](#).

9.5.1 Design Storms for Impoundments

9.5.1.1 General Considerations

Numerous design storm criteria are employed in hydrologic analyses for water retention and flood control dams. The common factor associated with practically all of these criteria is that differentiations are made based on the projected maximum size of the impoundment and the magnitude of potential downstream hazard in the event of failure. MSHA has developed guidelines for design storms for the impoundments and embankments that they regulate; however, state and local criteria must also be considered. For any impoundment, the most conservative of applicable criteria should be used.

As part of the identification of the design storm, the size of the dam and reservoir and the associated hazard potential is typically determined either by inspection or analysis. [Table 9.4](#) indicates appropriate design storms as related to impoundment size and hazard potential. Coal refuse impoundments should be designed for the Probable Maximum Flood (PMF) event, unless a lesser criterion can be justified consistent with [Table 9.4](#). For determining the impoundment size, the impoundment volume and depth should include all water, sediment, and slurry that can be impounded. For determining the hazard potential, both the water and flowable materials retained in the impoundment should be considered.

The PMF is defined as the maximum runoff condition resulting from the most severe combination of hydrologic and meteorological conditions that is considered reasonably possible for the watershed. A PMF consists of an antecedent storm, a principal storm and a subsequent storm. The current assumed conditions for a PMF design storm in the MSHA guidelines are the following (MSHA, 2007):

1. Antecedent storm – 100-year precipitation event, with antecedent moisture condition II (AMC II) occurring 5 days prior to principal storm.

TABLE 9.4 RECOMMENDED MINIMUM DESIGN STORM CRITERIA FOR COAL REFUSE DISPOSAL IMPOUNDMENTS

A. Impoundment Size Classification				
Category	Impoundment Size			
	Maximum Volume of Stored Water During Design Storm (acre-ft)		Maximum Depth of Water During Design Storm (ft)	
Small to Intermediate	< 1,000	or	< 40	
Large	≥ 1,000	or	≥ 40	
B. Hazard Potential Classification				
Category	Description			
Low Hazard Potential	Facilities where failure results in no probable loss of human life and low economic and/or environmental losses. Such facilities would be located in rural or agricultural areas where losses would be limited principally to the owner's property, or failure would cause only slight damage, such as to farm buildings, forest, and agricultural land, or minor roads.			
Significant Hazard Potential	Facilities where failure results in no probable loss of human life but can cause economic loss, environmental damage, or disruption of lifeline facilities. Such facilities would often be located in predominantly rural areas, but could be located in areas with population and significant infrastructures, and where failure may damage isolated homes, main highways, minor railroads or disrupt the use of service of public utilities.			
High Hazard Potential	Facilities where failure will probably cause loss of life. Such facilities would be located where failure could be reasonably expected to cause loss of life, serious damage to homes, industrial and commercial buildings, important utilities, highways and railroads.			
C. Recommended Design Storm for Long-Term and Short-Term Conditions ⁽¹⁾				
Impoundment Size	Hazard Potential	Minimum Design Storm for Long Term	Minimum Design Storm for Short Term ⁽¹⁾	Additional Criterion
Small to Intermediate	Low	100-Year	100-Year	The indicated storm is appropriate only if the combination of spillways and decants for the facility can evacuate 90 percent of the incremental volume of stored storm water within 10 days.
	Significant	½-PMF	100-Year	
	High	PMF	½-PMF	
Large	Low	½-PMF	100 Year	
	Significant	PMF	½-PMF	
	High	PMF	½-PMF	

Note: 1. Situations where short-term criteria may apply include:

- a. Initial construction. A new impoundment should be capable of accommodating the runoff from the short-term storm within one year and the long-term storm within two years.
- b. Changing from an open-channel spillway to handle the design storm by storage. The time period when the long-term design storm cannot be accommodated should be kept as short as possible with detailed planning of the process.
- c. Abandonment by elimination of impounding capacity. The impounding capability should be eliminated within two years after the impoundment can no longer accommodate the long-term design storm, and the work should be phased so that the facility is capable of accommodating less than the short-term storm for no more than one year.

2. Principal storm – Probable Maximum Precipitation (PMP) with AMC III. The principal storm rainfall must be distributed spatially and temporally to produce the most severe conditions with respect to impoundment freeboard and spillway discharge.
3. Subsequent storm – The subsequent storm criterion can be considered to be met if, within 10 days of the peak impoundment level associated with the principal storm, at least 90 percent of the volume of water stored above the normal operating level can be discharged from the impoundment. Alternatively, for facilities designed with sufficient storage but limited discharge capabilities that do not meet this criterion, the subsequent storm may be a second PMP storm with the same hydrologic and meteorological parameters as the principal storm, provided that the storage from both storms is drawn down at a rate sufficient to evacuate 90 percent of one storm from the impoundment within 30 days.

The antecedent storm precipitation can be obtained from National Weather Service publications. The most current definition of PMP (NWS, 1988) is “theoretically, the greatest depth of precipitation for a given duration that is physically possible over a given size storm area at a particular geographical location at a certain time of the year.” The PMP can be determined from the National Weather Service publications discussed in the following paragraphs.

In the Western U.S., determination of the PMF may be based upon either: (1) the PMP and (2) the Probable Maximum Thunderstorm (PMTS). The PMTS is a very high-intensity, short-duration storm with intense precipitation occurring during a one-hour period. When designing a coal refuse disposal facility in this region, the more critical of these two criteria should be used. In this Manual, the term PMP represents the more severe of the PMP and PMTS for areas of the U.S. west of the 105th meridian.

Dams or impoundments used for fine coal refuse disposal, fresh water retention, erosion and sediment control or other mine-related operations may need to have PMF storage/routing capacity. Less critical impoundments may have reduced design storm criteria based on embankment size and the potential downstream hazard. For such structures, both the 6-hour and 24-hour precipitation intensity (unless criteria are specified by state regulations) should be evaluated and the more conservative used for design.

As with water-impounding dams, basic design storm criteria apply to the long-term operation of coal refuse disposal facilities. However, short-term criteria, as summarized in [Table 9.4](#), may be used for construction periods that typically extend from several months to two years for impounding structures subject to PMF design storm criteria. The designer of coal refuse disposal facilities must take into account that the configuration of the impounding embankment will be continually changing as additional refuse is placed and that the time associated with any one phase or the time between phases may be quite short. This can be accounted for by additional or modified design storm criteria presented in [Section 9.6](#). These modified criteria should only be used for “unavoidable” situations that occur: (1) during short-term operations associated with initial construction of a disposal facility, (2) when a major modification is being made to an existing disposal facility, and (3) when a refuse disposal facility is being prepared for abandonment.

For water-retaining impoundments, different design storms are sometimes used for individual portions of the total hydraulic system such as the principal spillway and auxiliary spillway (NRCS, 2005b). This practice is generally not followed in the design of coal refuse disposal facilities provided the overall hazard criteria are satisfied because of the operational characteristics of a disposal facility, the dynamic nature of facility growth and the limited operational period. This practice may be applicable to other impounding facilities that support the mining operations (e.g., fresh water impoundment, sediment ponds, etc.).

In the design of coal refuse disposal facilities, it is important to differentiate between the functions of spillways and decants. The main function of a decant system is to discharge clarified water from the impoundment after the fine refuse has settled. Under normal precipitation conditions, the elevation of the decant inlet controls the normal operational water level in the impoundment. The capacity of a decant is limited and is typically too small to significantly affect the peak outflow during a large storm. Therefore, the storm runoff is almost totally controlled by impoundment storage or a combination of impoundment storage and auxiliary spillway capacity.

Even though an impoundment decant system does not have a significant impact on the outflow during the design storm, its capacity must be considered in other analyses related to storms. If the auxiliary spillway level is above the normal impoundment level (the typical condition) or if the hydraulic system design relies entirely on storage (no auxiliary spillway), the excess storm runoff must either be discharged totally through the decant system, or the decant system must serve as the primary outlet until the spillway level is reached. As indicated in [Table 9.4](#), within ten days, the combined capacity of the spillway and decant systems must be capable of removing 90 percent of the maximum volume of water stored above the allowable normal operating water level during the design storm. The 10-day drawdown criterion begins at the time the water surface reaches the maximum elevation associated with the design storm. Alternatively, if there is sufficient impoundment capacity to store the runoff from two design storms (specifically, the antecedent storm and two principal storms), an extension of the 10-day criterion is reasonable, provided that an effective means for discharging the storage from both storms is available. Generally, an evacuation rate that will remove 90 percent of the stored runoff from one design storm within 30 days is considered to be reasonable.

9.5.1.2 Recommended Design Storm Criteria

Table 9.4 provides recommended minimum design storm criteria for coal-mining-related impounding facilities for both long-term and short-term conditions. Selection of the appropriate storm for a specific impounding structure is based on the impoundment size and hazard-potential classification. The selected criteria for the storage and routing of the design storm and hydraulic structure design should also reflect any other applicable regulatory reviewing agency criteria.

Dams and impoundments that are small to intermediate in size (less than 40 feet in height or 1,000 acre feet in storage volume) with low hazard potential should be designed for a long-term storm event with no less than a 100-year recurrence interval. For coal refuse impoundments equal to or greater than 40 feet in height or 1,000 acre feet in storage volume with low or significant hazard potential, the minimum long-term design storm should be either the ½ PMF or full PMF, respectively. The ½ PMF design storm should have one-half of the inflow rate and runoff volume of the full PMF. For coal refuse impoundments with high hazard potential, the minimum long-term design storm should be the full PMF. In cases where the design storm for long-term conditions is less than the full PMF, it may be prudent to adopt minimum design storm criteria greater than those provided in [Table 9.4](#) and thus achieve greater protection from flood events and related damage.

The following paragraphs discuss the basis and/or justifications for criteria and information presented in [Table 9.4](#). Procedures for quantitatively determining the magnitude of precipitation to be used in the calculation of runoff are discussed in [Section 9.6](#).

9.5.1.3 Size and Hazard-Potential Classification

The rationale for relating the design storm to the size and hazard potential of the disposal facility impoundment is evident. Impoundment size is defined by the maximum depth and total volume of retained water, sediment and slurry; however, determining the hazard-potential classification requires judgment and, unless otherwise obvious, should be based upon hydraulic analyses. The bases for the criteria listed in [Table 9.4](#) are discussed in the following subsections.

9.5.1.3.1 Impoundment-Size Classification

The size classification presented in [Table 9.4](#) is based on the total volume and depth of all water, sediment and slurry impounded during the design storm. As indicated in the table, the recommended design storms for small and intermediate size impoundments are the same.

9.5.1.3.2 Hazard-Potential Classification

The hazard-potential classification presented in [Table 9.4](#) is the same as that presented in [Chapter 3](#) and used in the overall classification system for coal refuse disposal facilities. Dams that are located where loss of life is probable in the event of failure are classified as having high hazard potential. In applying these criteria, it is important to recognize the difficulty of determining whether minor or major damage or the loss of life will result from the failure of a refuse disposal facility. For most coal refuse disposal facilities, this determination is based upon: (1) the configuration and location of the facility and (2) the downstream conditions (both existing and planned) including population, topography and the size of streams that would receive flood flow resulting from an embankment failure or a breakthrough-type release from the impoundment. Downstream conditions are typically evaluated by reviewing USGS topographic quadrangle maps and by field verification. The manner that MSHA addresses the hazard associated with a breakthrough-type release is discussed in [Section 3.1](#).

Generally, unless it is otherwise evident, the determination of hazard potential is based upon a dam or impoundment breach analysis and inundation mapping. [Section 9.9](#) presents dam-breach-analysis methods. A dam-breach analysis should provide inundation levels for two conditions: (1) postulated failure of the dam under design-storm conditions and (2) postulated failure of the dam during normal operations (sunny day or fair weather breach failure). If doubt exists as to the possible effects of an impoundment failure on downstream areas, the more conservative hazard classification should be selected. However, it may also be useful to evaluate the downstream inundation and damage that could result from a major storm in the refuse disposal facility watershed, but without failure of the impoundment. This inundation level and related damage can then be compared to the incremental inundation and damage that would be caused by failure of the disposal facility under design-storm conditions. If the additional damage can be reasonably predicted as small, then a less conservative design storm may be appropriate (FEMA, 2004a), or the hazard-potential classification may be governed by the fair weather breach.

For most large dams and impoundments where downstream residential, commercial or industrial development is present adjacent to streams, a high-hazard-potential classification is selected based on probable loss of human life. Other situations can arise where the threat is less evident or where the distinction between significant and low hazard potential is important. FEMA (2004a) provides guidance for interpreting the probable loss of life by clarifying that “postulating every conceivable circumstance that might remotely place a person in the inundation zone should not be the basis for determining the appropriate classification level.” In the definition of high hazard potential, the probable loss of human life is clarified to exclude consideration of the casual user of downstream or upstream areas. However, personnel who routinely or frequently work or occupy locations or structures in the downstream area should be considered in the assessment of hazard-potential classification.

USBR (1988) provides guidance based upon the number of lives in jeopardy (all individuals within the inundation boundaries who, if they took no action to evacuate, would be subject to danger) to aid in assessing the potential for probable loss of life. In cases where a dam-breach analysis indicates limited inundation at occupied structures in relatively undeveloped areas, such guidance in assigning hazard potential may be useful. USBR (1988) provides guidelines for interpreting the significance of predicted inundation depth and velocity at downstream residences, roadways, and pedestrian routes.

There have been a limited number of mining situations, primarily in the western United States, where high-hazard-potential dams have been designed using hydrologic design criteria associated with a lower hazard-potential-classification and incorporating a warning system. An example is a dam constructed across a watercourse for prevention or mitigation of flooding damage to a surface mine pit. To design a flood-control structure to totally accommodate the design event would necessitate the construction of a very large dam that would function only temporarily. Failure of this dam could possibly result in a higher hazard potential due to the additional storage. In such cases, some designers have proposed dams using low- or significant-hazard-potential criteria and incorporating warning systems. The warning systems are designed to notify the mining operation when the water behind the dam reaches a specified level. At that time, all potentially affected personnel are withdrawn from the downstream area. Allowance for warning time must not be a substitute for appropriate dam design and construction. MSHA (Fredland, 2008) has indicated that this approach may be acceptable on a case-by-case basis for temporary mining operations. Conditions associated with warning systems for this approach are discussed in [Section 3.7](#).

Hazard-potential classification is also dependent on the potential for economic, environmental or lifeline losses. If a dam or impoundment is not classified as having high hazard potential because there is no probable loss of human life, generally it reflects a situation where there are few downstream structures and thus limited potential for associated economic damages. FEMA (2004a) clarifies that for classification of a dam as having low hazard potential (as opposed to significant hazard potential), the economic, environmental or lifeline losses must be low and generally limited to the owner of the structure. While economic damages to downstream development may be determined to be low and thus could support classification of a dam as having low hazard potential, the possibility of environmental damages may warrant consideration of higher hazard classification levels.

9.5.1.4 Determination of Design Storm Precipitation

Once the size and hazard-potential classification of a disposal facility impoundment are established, the recommended design storm can be determined from [Table 9.4](#). The procedure for determining the magnitude of the precipitation for the design storm is discussed in the following paragraphs, while the procedure for computing the resulting runoff is presented in [Section 9.6](#).

9.5.1.4.1 Prediction of the PMP and PMTS

Predictions of the PMP (inches of rainfall) for a watershed of 10 square miles and durations of 6 to 72 hours are presented in reports prepared by the National Weather Service's Hydrometeorological Design Studies Center. [Figure 9.14](#) identifies applicable Hydrometeorological Reports (HMRs) for various regions of the U.S. For areas east of the 105th meridian, HMR 51 (NWS, 1978) should be used for determining the PMP magnitude and for extending the PMP to longer durations. The only exception is an area in the Tennessee River Valley that is addressed in HMR 56 (NWS, 1986). Procedures for determining critical rainfall spatial and temporal distribution for areas east of the 105th meridian are provided in HMR 52 (NWS, 1982); however, the document may not be applicable to all watersheds, particularly watersheds with areas less than 10 square miles. Seasonal variation of PMP for areas east of the 105th meridian is addressed in HMR 53 (NWS, 1980). For the region between the 103rd and 105th meridian, HMR 55A (NWS, 1988) and HMR 52 should be used. For the area between the 103rd meridian and the continental divide, HMR 55A is applicable. For areas west of the continental divide, HMR 49 (NWS, 1977), HMR 57 (NWS, 1994), HMR 58 (NWS, 1998), or HMR 59 (NWS, 1999) should be used, as indicated by the shaded areas in [Figure 9.14](#).

As indicated above, HMR 56 (NWS, 1986) was developed for the Tennessee Valley. While HMR 56 is recommended for projects in that region, the study indicates that in non-orographic areas numerous comparisons were made between the results from HMR 56 and the results from HMR 51 and HMR 52, indicating that minor differences in results can be expected depending upon the size of the study

region. In more mountainous orographic areas, HMR 56 provides guidance for determining the areal distribution of storm-averaged depths with reference to HMR 52.

The extension of the PMP for watersheds exceeding 10 square miles and other durations are discussed in relation to analyses for determining runoff in Section 9.6. For coal refuse disposal impoundments, the applicable watershed is typically much smaller than 10 square miles, resulting in no or only limited adjustments for spatial distribution using HMR 52 (NWS, 1982). Because impoundments are designed with considerable storage capacity, and in many cases the ability to store the runoff from the entire design storm, determination of adjustments that affect the peak inflow rate may not be nec-

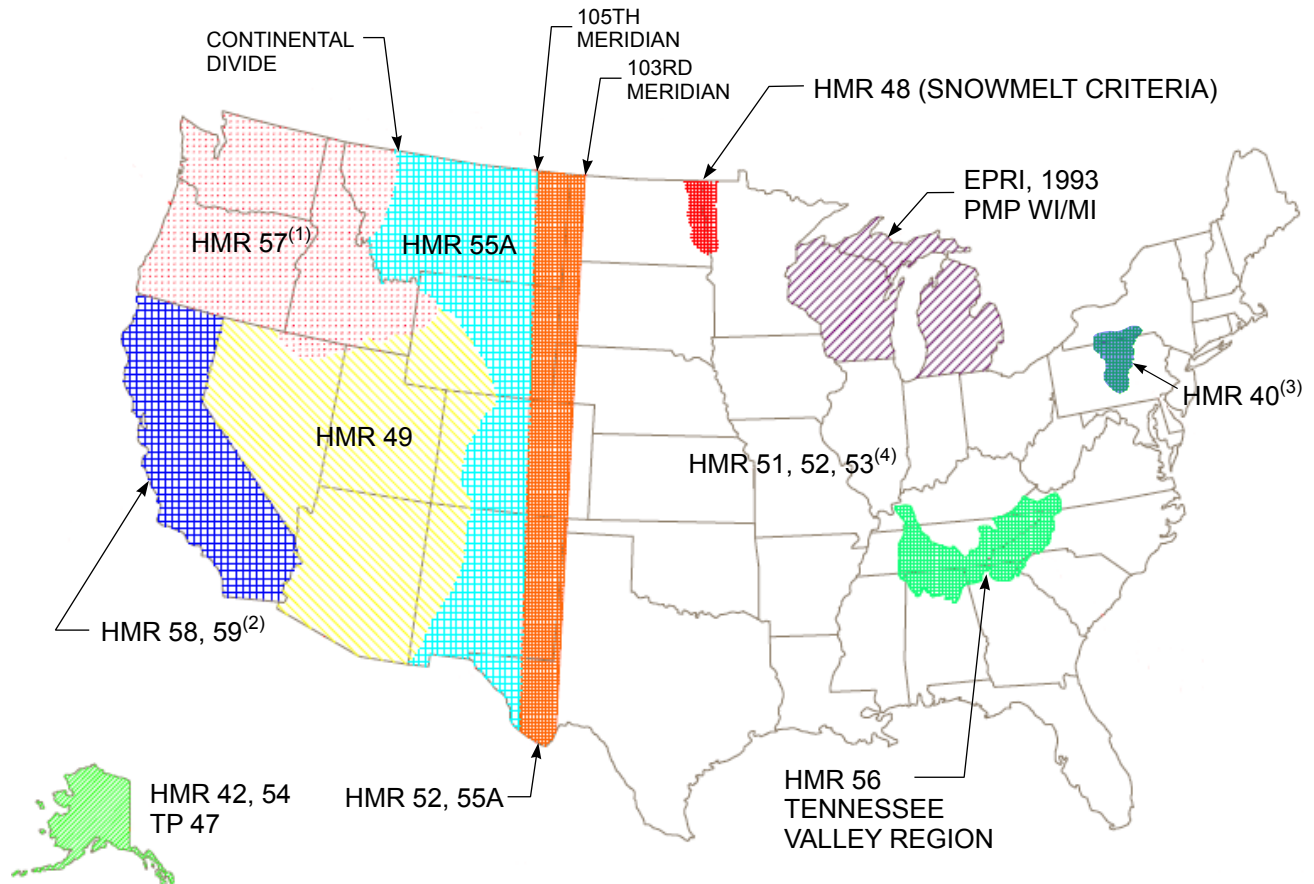

NOTE: 1. HMR 57 REPLACED HMR 43 IN 1994.
 2. HMR 58 AND 59 REPLACED HMR 36 AND 49 FOR CALIFORNIA IN 1999.
 3. HMR 51, 52, 53 MAY APPLY FOR BASINS UNDER 24,000 SQUARE MILES.
 4. HMR 33 (SEASONAL PMP VARIATIONS FOR AREAS NOT SUPERCEDED BY SITE-SPECIFIC SEASONAL PMP REPORTS)

(ADAPTED FROM FERC, 2001)

FIGURE 9.14 U.S. REGIONS COVERED BY GENERALIZED PMP STUDIES

essary. However, in such cases the PMP must generally be extended to 72 hours. For impoundments with watershed areas as small as one square mile that rely on open-channel spillways for routing the PMF, HMR 52 (NWS, 1982) provides a means for estimating the adjusted PMP distribution using depth-duration ratios and 1-hour PMP values.

9.5.1.4.2 Prediction of the 100-year and Lesser Design Storms

The 100-year-recurrence-interval design storm and lesser design storm precipitation data can be obtained from several sources. NOAA Atlas 14 Volume 1 (NWS, 2006a) and Volume 2 (NWS, 2006b) provide rain-

fall frequency values for much of the U.S., and NOAA Atlas 2 (NWS, 1973) provides data for some areas of the western U.S not covered in Atlas 14 Volume 2. Other areas of the country are addressed in various technical publications available from NOAA or in other sources listed in [Table 9.5](#). Access to precipitation, frequency, and intensity data for specific locations is available from the NOAA web site.

The current practice of precipitation frequency analysis is based upon the implicit assumption that past experience can be used to predict future events and that the climate will not change. In its current studies, the NWS is assuming that the full period of the available historical record is suitable for use, as current climate change forecasts do not reliably define future changes in precipitation frequency distribution.

9.5.2 Special Considerations for Short-Term Conditions

Although coal refuse disposal facilities are typically dynamic or constantly changing entities, careful consideration of growth characteristics and proper planning of modifications will result in compliance with long-term design storm criteria over the facility's entire service life. Occasionally, however, it may be impossible to meet long-term requirements during brief periods when significant physical changes to the facility are occurring.

Appropriate design storms for short-term conditions are provided in [Table 9.4](#). Short-term conditions for periods of significant physical change are more related to general construction practices, and therefore the criteria for temporary (stream) diversions are generally dictated by state guidelines. The upper limit for a short-term condition is two years. The short-term design storms provided in [Table 9.4](#) are more conservative (higher) than those normally used for dam construction (USBR 1987a). The more stringent criteria are recommended because planning and implementation of modifications at coal refuse disposal facilities are dependent upon day-to-day coal and refuse generation unlike other types of embankments.

It is stressed that these short-term criteria are not intended as less costly design alternatives based on the rationale that a short-term condition is always appropriate for a given site because it is continually changing in configuration. If such an approach is followed, it should be expected that regulatory acceptance of a lesser storm will not be granted. The temporary use of design storms of lesser magnitude than those required for long-term facility operation will likely be accepted only if the following conditions are met:

- The facility will be designed to satisfactorily meet the requirements for such interim use, including, but not limited, to safe control of the short-term design storm.
- As part of the overall design and planning process, interim periods of short-term use are unavoidable and are identified and their duration realistically scheduled. As these periods are approached during construction, the scheduling of these transitional periods should be adjusted as required and thereafter strictly followed. Such preplanning and scheduling should be done in a manner that minimizes the duration of the short-term condition and facilitates the speedy transition to either a long-term operating status or abandonment.

Periods during the service life of a refuse disposal facility when even careful planning may occasionally be insufficient to achieve compliance with long-term design criteria include:

- Initial construction of a new impounding structure. The impoundment should be capable of accommodating the runoff from the short-term storm within one year and the long-term storm within two years.
- Transitioning from a lower open-channel spillway to a higher open-channel spillway as part of raising the embankment stage crest or changing from an open-channel spill-

way to handling the design storm by storage. The time period when the long-term design storm cannot be accommodated should be kept as short as possible, and a comprehensive plan and schedule for the sequence of the change should be provided.

- Abandonment by elimination of impounding capability. The impounding capability of the facility should be eliminated within 2 years after the time that the impoundment can no longer accommodate the long-term design storm. Additionally, abandonment should be phased such that the time period when the facility is capable of handling less than the short-term storm is no more than one year.

TABLE 9.5 NWS PRECIPITATION FREQUENCY PUBLICATIONS

Location	Design Storm Duration		
	5 to 60 min	1 to 24 hrs	2 to 10 days
DE, IL, IN, KY, MD, NJ, NC, OH, PA, SC, TN, VA, DC	NOAA Atlas 14 Volume 2 (NWS, 2006b)	NOAA Atlas 14 Volume 2 (NWS, 2006b)	NOAA Atlas 14 Volume 2 (NWS, 2006b)
Remainder of Eastern United States	Technical Memorandum NWS HYDRO-35 (Frederick et al., 1977)	Technical Paper 40 (Hershfield, 1961)	Technical Paper 49 (NWS, 1964)
AZ, NV, NM, UT, Southeast CA	NOAA Atlas 14 Volume 1 (NWS, 2006a)	NOAA Atlas 14 Volume 1 (NWS, 2006a)	NOAA Atlas 14 Volume 1 (NWS, 2006a)
Remainder of Western United States	Arkell and Richards (1986); Frederick and Miller (1979)	NOAA Atlas 2 (NWS, 1973)	Technical Paper 49 (NWS, 1964)
Alaska	Technical Paper 47 (NWS, 1963)	Technical Paper 47 (NWS, 1963)	Technical Paper 52 (NWS, 1965)

(ADAPTED FROM NRCS, 1986)

9.5.3 Hydraulic Design Criteria for Drainage Conveyance Installations

Hydraulic structures for both non-impounding and impounding coal refuse disposal facilities fall into three general categories:

1. Those structures that by failure, overtopping and/or blockage could threaten the overall stability of the disposal facility.
2. Those structures that by failure, overtopping and/or blockage would not threaten the overall stability of the disposal facility, but could lead to localized instability.
3. Those structures that, even if non-functional, would not endanger the overall stability of the facility and would not greatly affect day-to-day operation of the facility.

Hydraulic structures that are critical to the overall safety of coal refuse disposal facilities must be designed to adequately control the facility design storm. Although this most commonly applies to the hydraulic structures associated with impounding facilities, the requirement applies equally to hydraulic structures at non-impounding facilities. Permanent hydraulic structures (other than impoundment spillways) at coal refuse disposal embankments should be designed to handle the 100-year storm.

The purpose of many refuse disposal facility permanent hydraulic structures is to limit erosion or other types of localized instability rather than to provide total hydraulic control during major storms. Whether or not a facility is impounding, non-impounding, active or abandoned, these structures are

important to the development and operation of a disposal facility and should generally be designed for the 100-year storm. Design criteria for these structures may also be governed by state or local regulations. Table 9.6 provides a summary of typical design criteria for minor hydraulic structures at locations that are not part of the coal refuse disposal facility. These structures typically include storm sewers, culverts, drainage ditches and gutters.

9.6 DETERMINATION OF RUNOFF QUANTITIES

The most important aspects of hydrologic analyses related to refuse disposal facility performance during and after storm rainfalls are the determination of the peak runoff rate and the total runoff volume at the point of interest. Four methods for determining these parameters that are available to the designer are presented in Table 9.7. The first three methods presented in the table are discussed in this section following a general discussion of basic hydrology parameters.

9.6.1 Basic Hydrology Parameters

There are three basic factors that must be considered when predicting runoff rates and quantities. These are: (1) precipitation (intensity and duration), (2) watershed (size and time of concentration), and (3) soil types and land use conditions. These factors are further explained in the following subsections.

9.6.1.1 Precipitation Intensity-Duration and Distribution

Storms are defined by their precipitation intensity-duration relationships. Storms can range from high-intensity, short-duration thunderstorms to low-intensity, long-duration rainfalls lasting several days. The intensity-duration relationship that should be used for hydrologic analyses and channel design is that which produces the maximum peak runoff rate. This is particularly true for the small watersheds common to coal refuse facilities where the time of concentration (time required for rainfall to travel from the most hydrologically distant point in the watershed to the point of interest) is

TABLE 9.6 TYPICAL DESIGN CRITERIA FOR MINOR HYDRAULIC STRUCTURES⁽¹⁾

Structure Type and Condition	Design Criteria
Storm Sewers	10-year rainfall
Diversion Systems	
<u>Temporary</u> (1-year life or less and watershed > 5 acres)	
Construction areas, roads, pipelines	2-year rainfall
<u>Permanent</u>	
Sediment Retention Structures (watershed <100 acres and height < 15 feet):	10-year rainfall
Emergency spillway capacity	25-year, 24-hour rainfall
Principal spillway capacity	10-year, 24-hour rainfall
Culverts:	
Access Roads and Drainage Swales	10-year, 24-hour rainfall
Local and Urban Roads	25-year, 24-hour rainfall
Highways and Streams	100-year, 24-hour rainfall
Drainage Ditches and Gutters	10-year rainfall

Note: 1. These criteria do not apply to minor structures on coal refuse disposal facilities. Permanent perimeter ditches and bench gutters on coal refuse disposal facilities should be designed for the 100-year storm.

TABLE 9.7 METHODS FOR DETERMINING RUNOFF RATE AND VOLUME

Method	Applicable Conditions
Hydrograph Method (Section 9.6.2)	Applicable to all runoff analyses, but normally used when a time-related runoff distribution is required or when less exact methods for estimating runoff are not sufficiently accurate for design of an economical drainage system.
Peak Runoff Determination (Section 9.6.3)	For (1) determining estimates of peak runoff rate and runoff volume for system sizing when time-related runoff distribution is not required for final design or (2) preliminary system sizing prior to generating a runoff hydrograph for flood routing.
Rational Method (Section 9.6.4)	For designing drainage conveyance structures such as diversion and collection ditches and road culverts for small watersheds.
Stream Gage Data Analysis (USDA, 1972; Chow, 1964)	For predicting runoff by statistical analysis of measured stream flow records when a long history of data is available for the stream or for a nearby similar stream and watershed. Since these data are not generally available for the types of streams passing through or adjacent to coal refuse disposal facilities, methods using stream flow records are not presented herein.

small. In larger watersheds, the averaging effects of short and long times of concentration tend to compensate for small errors in the predicted intensity-duration relationship.

Figure 9.15 presents the dimensionless design storm distribution frequently used to evaluate the intensity-duration relationship (NRCS, 2005b) based upon a 6-hour-duration storm. The 24-hour storm can be constructed by critically stacking incremental rainfall amounts for successive 6-, 12-, and 24-hour durations, as discussed in HMR 52. Runoff determinations for mining facilities are typically based upon either 6-hour- or 24-hour-duration precipitation events (with extension to periods up to 72 hours for impoundments that rely on storage for flood routing) except for states west of the 105th Meridian where PMTS runoff must also be considered.

As indicated in Table 9.4, development of specific-frequency flood hydrographs may be required for the design of structures with low- or significant-hazard-potential classification. High-hazard-potential structures require design for the PMF, which for coal refuse disposal facilities is typically derived from the PMP for the watershed. The PMP is a 6- to 72-hour duration precipitation distribution that results in a peak intensity occurring during the third quadrant of precipitation. This distribution curve is recommended for most coal refuse impoundment hydrologic design and analysis applications. For smaller impounding structures, it is recommended that both short-duration (6-hour) and long-duration (24-hour) storms be utilized to determine the peak runoff for sizing of the outflow structures.

In addition to knowing how the intensity of precipitation may be distributed within a six-hour storm, it is also important to recognize that storms may continue for longer periods of time at decreasing intensities. Such storms may be critical for disposal facilities that rely primarily on reservoir storage to control runoff, since the amount of runoff occurring after the first six hours may represent a significant portion of the runoff volume of the total storm. HMR 51 and HMR 52 can be used to extend the predicted six-hour PMP.

Figure 9.14 shows applicable HMRS for determining magnitudes and temporal distributions for probable maximum storms based upon regionalized criteria. Charts for PMP values are presented in HMR 51 for most areas east of the 105th Meridian, and procedures are provided in HMR 52

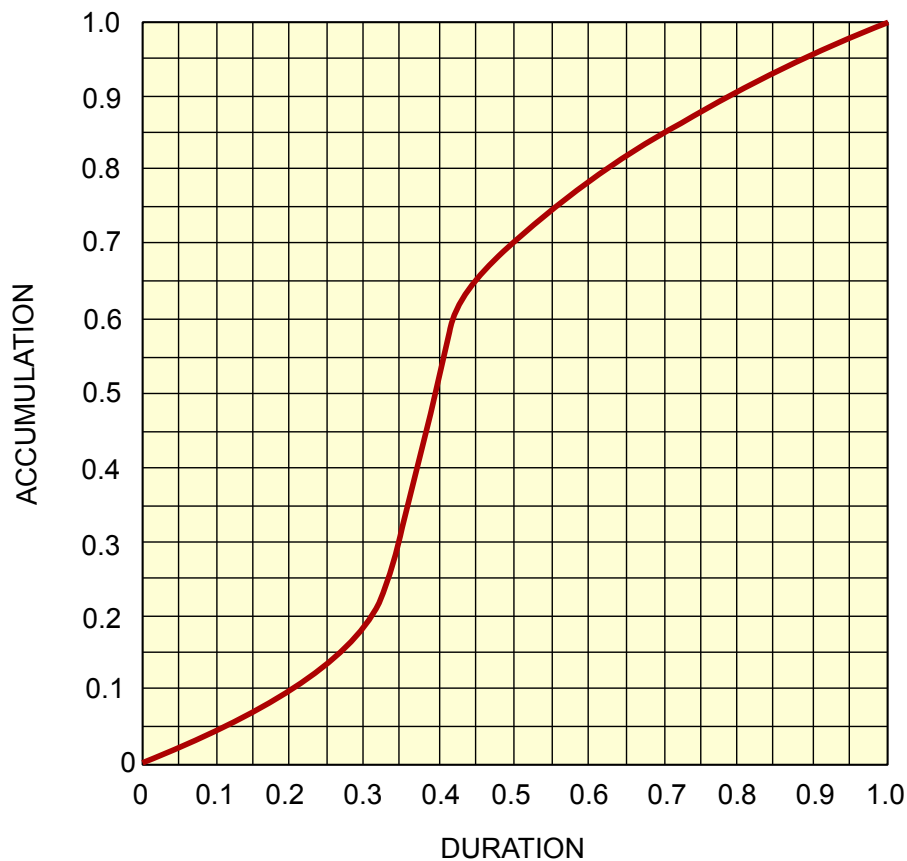

(NRCS, 2005b)

FIGURE 9.15 DIMENSIONLESS DESIGN STORM DISTRIBUTION

that translate these values to a spatially and temporally distributed estimate of the site PMP. The computer program HMR 52 developed by the U.S. Army Corps of Engineers (USACE, 1984b) determines the most severe storm conditions considering basin characteristics and regional conditions that are critical for watersheds with areas greater than 10 square miles. For many coal refuse impoundments, watersheds are small (typically less than 1 square mile) and the procedures in the computer program HMR 52 may need to be adjusted for these smaller watersheds using methods presented in NWS (1982).

HMR 56 is applicable in the Tennessee Valley region. For the region between the 105th Meridian and the Continental Divide, HMR 55A should be used. Probable maximum storm estimates for areas west of the Continental Divide may be developed using HMR 49, HMR 57, and HMR 59, which account for orographic effects and include procedures for evaluating local (thunderstorm) PMP storms.

Short-term design storm criteria and low-hazard-potential dam design criteria require precipitation frequency information that is available from NOAA, as indicated in [Table 9.5](#).

9.6.1.2 Unit Hydrographs and Time of Concentration

Unit hydrograph theory is the basis for computing inflow hydrographs for design storms. A unit hydrograph can be derived from observed hydrographs recorded on gauged streams, although for most coal refuse disposal facilities located in small watersheds, they are synthesized using relationships between rainfall and runoff that are dependent on watershed conditions. Empirical equations are typically employed to estimate parameters for synthetic unit hydrographs, although some government agencies can provide parameters for ungauged stream basins, including:

- USACE has developed coefficients for use in computing Snyder and Clark unit hydrographs for some areas of the U.S. USACE district offices can provide information on the results of studies in their districts.
- The USBR has developed a set of lag-time equations, dimensionless unit hydrographs, and S-graphs for different parts of the western U.S. (Cudworth, 1989).
- The USGS has performed regional studies for development of unit hydrographs in cooperation with state departments of transportation. These are published as USGS water resources investigation reports. Some of these are applicable to the states of Illinois, Tennessee, and Alabama (Graf et al., 1982; Robbins, 1986; Olin and Akins, 1988).

Before applying published parameters for watersheds in a region, the possible effects of differences in drainage area, cover, soil type, orientation, or geology should be evaluated. Additionally, the terminology used to define the various hydrographs and basin parameters in a regional study should be carefully reviewed so that application to ungauged watersheds is consistent (e.g., lag time and channel slope may be defined differently in the various methodologies).

If published parameters for watersheds in the region are not available, and the drainage basin is larger than about 100 square miles, a regional analysis may be prepared by analyzing rainfall and streamflow records at gauged watersheds to relate the peak flow rate and lag time to the drainage area. Procedures are described in FERC (2001).

The most common method available to designers for the small watersheds typically associated with coal refuse disposal facilities is based on empirically derived coefficients for synthetic unit hydrographs. The common methods for developing parameters from empirical equations include the Clark, Snyder and SCS unit hydrograph procedures. These methods are incorporated into the widely used computer programs for development of inflow design floods (e.g., HEC-1 and HEC-HMS developed by the U.S. Army Corps of Engineers Hydraulic Engineering Center (HEC) and similar privately marketed programs).

9.6.1.2.1 Snyder Unit Hydrograph

The equations used for the Snyder unit hydrograph are (USACE, 1990b):

$$t_p = C_t(L L_{ca})^{0.3} \quad (9-1)$$

$$C_p = (Q_p t_p) / (640A) \quad (9-2)$$

t_p = time lag measured from the centroid of precipitation excess to the time of peak flow at the point of interest (hr)

L_{ca} = length along the main watercourse measured from the outlet upstream to a point nearest the basin centroid (mi)

L = length of the main watercourse (mi)

Q_p = peak flow rate of the unit hydrograph (cfs)

A = drainage area (mi²)

The coefficients C_t and C_p are empirical values applicable to specific regions that account for watershed storage and slope and flood-wave velocity and channel storage, respectively. These parameters are obtained from regional studies and, if they are representative of conditions of the

watershed being analyzed, are entered into HEC hydrologic software for a Snyder unit-hydrograph analysis.

9.6.1.2.2 Clark Unit Hydrograph

The Clark unit hydrograph uses a time-area curve to represent the watershed and uses a computed time of concentration (T_c) that can be calculated based on SCS procedures unless more reliable regional data are available. Additionally, the Clark unit hydrograph also uses a coefficient that reflects the effect of storage within the watershed. HEC hydrologic software (e.g., HEC-1) can be used to calculate the value of this coefficient through its optimization routine, but the result obtained should be evaluated and compared to published or available regional data. The Clark method is usually not employed for the small watersheds that are typically associated with coal refuse disposal facilities.

9.6.1.2.3 SCS Dimensionless Unit Hydrograph

The SCS method is the most commonly used approach for small watersheds and is frequently used for coal refuse disposal facility design. The primary analytical requirement for this method to be applied in a HEC-1 analysis is the estimation of the lag time for the basin, which is generally assumed to be equal to $0.6 T_c$.

Time of Concentration and Lag Time

The time of concentration T_c is the time required for runoff to travel from the most hydrologically remote point in the watershed to the point of interest (Figure 9.2). The hydrologically most distant path within a watershed may not necessarily be along the longest water course; therefore, various watershed length and slope combinations should be evaluated.

Empirical equations have been developed by the SCS, the USBR, and others for estimation of T_c as a function of the length, surface texture and vegetation, and watershed slopes. Additionally, T_c may be computed by analysis of the overland and channel flow travel time using surface drainage software. A common method is to use the computer program TR-55 to determine flow velocity and associated time of concentration for subbasins within a watershed and thus estimate T_c . Empirical equations for determination of T_c are presented below.

USBR Method

The USBR (1973) determined T_c from the following equation that has historically been applied to small watersheds for design of small dams and coal refuse disposal facilities:

$$T_c = [(11.9L^3)/H]^{0.385} \quad (9-3)$$

where:

T_c = time of concentration (hr)

L = length of longest watercourse in watershed (mi)

H = elevation difference between the highest and lowest points in the watershed (ft)

For watersheds west of the 105th meridian and forested mountain watersheds east of the 105th meridian, Table 9.8 lists correction factors that should be applied to T_c , as predicted by Equation 9-3. The Modified Snyder Method developed by USBR (1987a), which is discussed in subsequent paragraphs, is now more commonly used.

TABLE 9.8 RECOMMENDED CORRECTION FACTORS FOR T_c FOR WATERSHEDS WEST OF THE 105TH MERIDIAN

CN	T'_c / T_c
80	1.0
70	1.4
60	1.8
50	2.2

(USBR, 1973)

SCS Methods

The lag method developed by the Natural Resources Conservation Service (NRCS, 1986), also referred to as the curve-number method, applies to areas less than 2,000 acres:

$$T_c = \frac{5}{3} [(L^{0.8}(S+1)^{0.7})/1900 Y^{0.5}] \quad (9-4)$$

where:

- S = $(1000/CN) - 10$
- L = hydraulic length of watershed (ft)
- Y = average watershed land slope (percent)
- CN = curve number (dim)

The NRCS (1986) also developed an approach to determining time of concentration by computing the travel time (T_t) for runoff to traverse the watershed, considering three components of flow: (1) sheet flow in upland areas (generally applied to distances of 300 feet or less), (2) shallow concentrated flow as runoff concentrates beyond the sheet flow areas, and (3) open-channel flow as runoff is conveyed downstream. By summing the travel times, an estimate of T_c can be determined from the following relationship:

$$T_c = T_{t1} + T_{t2} + T_{t3} \quad (9-5)$$

Sheet Flow

$$T_{t1} = [0.007 (nL_1)^{0.8}] / (P_2^{0.5} s^{0.4}) \quad (9-6)$$

where:

- T_{t1} = sheet flow travel time (hr)
- n = Manning's roughness coefficient for sheet flow (Table 9.9)
- L_1 = flow length (ft)
- P_2 = 2-year, 24-hour rainfall (in)
- s = average watershed land slope (ft/ft)

TABLE 9.9 ROUGHNESS COEFFICIENTS (MANNING'S N) FOR SHEET FLOW

Surface Description	n
Smooth surfaces (concrete, asphalt, gravel, or bare soil)	0.011
Fallow (no residue)	0.05
Cultivated soils	
Residue cover $\leq 20\%$	0.06
Residue cover $\geq 20\%$	0.17
Grass	
Short grass prairie	0.15
Dense grasses ⁽¹⁾	0.24
Bermuda grass	0.41
Range (natural)	0.13
Woods ⁽²⁾	
Light underbrush	0.40
Dense underbrush	0.80

Note: 1. Includes species such as weeping lovegrass, bluegrass, buffalo grass, blue grama grass and native grass mixtures.

2. When selecting n, cover should be assumed to have a height of 0.1 foot. This is the only portion of the plant cover that will obstruct flow.

(NRCS, 1986)

Shallow Concentrated Flow

$$T_{t2} = L_2 / (3600 V_2) \quad (9-7)$$

where:

T_{t2} = shallow concentrated flow travel time (hr)

L_2 = flow length (ft)

V_2 = average velocity (ft/sec) from [Figure 9.16](#)

Open-Channel Flow

$$T_{t3} = L_3 / (3600 V_3) \quad (9-8)$$

$$V_3 = (1.49 R^{0.67} s^{0.5}) / n$$

where:

T_{t3} = open-channel-flow travel time (hr)

L_3 = channel flow length (ft)

R = hydraulic radius = cross-sectional-flow area/wetted perimeter (ft)

s = slope of the channel (ft/ft)

n = Manning's roughness coefficient ([Section 9.7.2.2](#))

V_3 = average channel flow velocity (ft/sec)

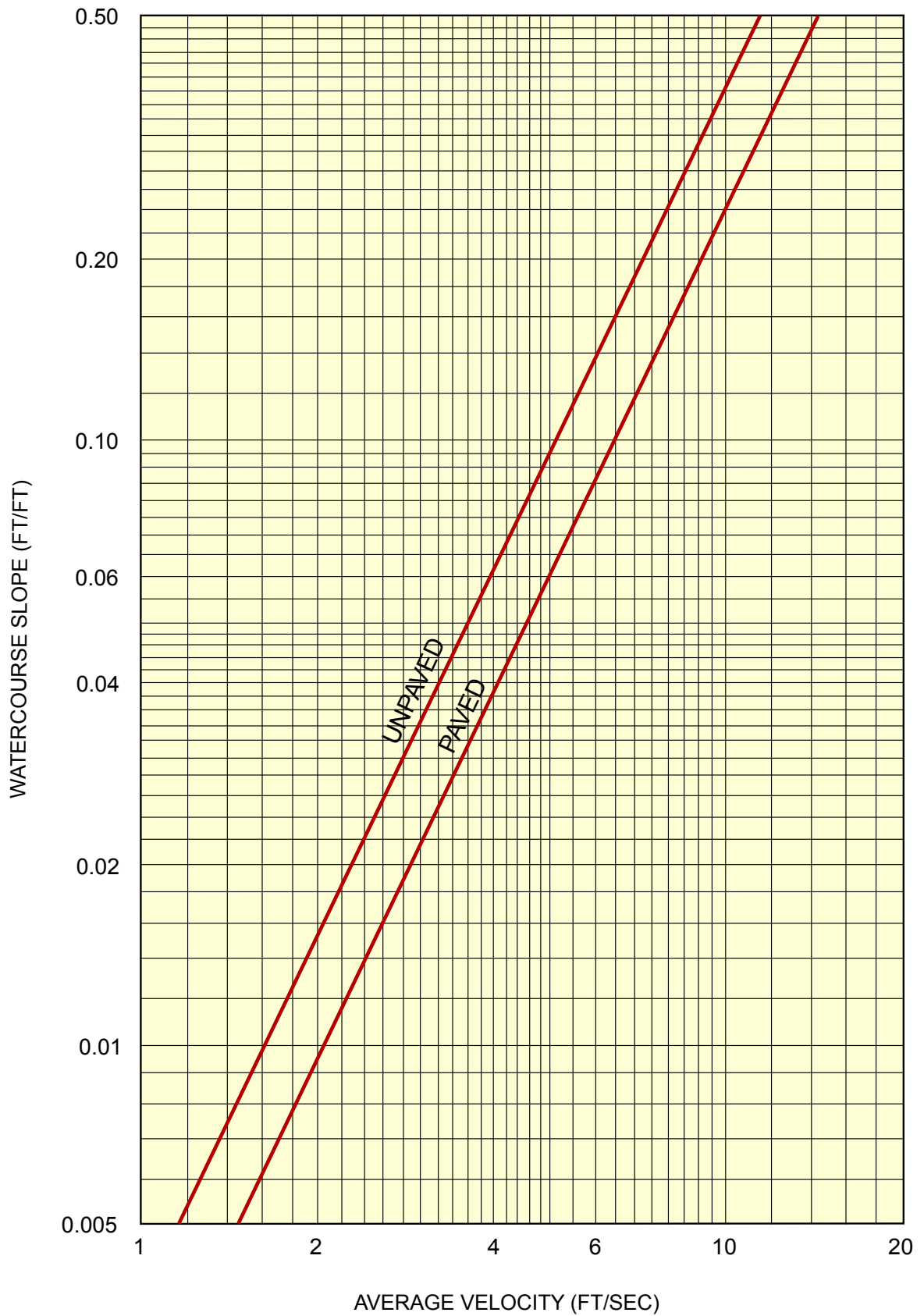

(NRCS, 1986)

FIGURE 9.16 AVERAGE VELOCITIES FOR ESTIMATING TRAVEL TIME FOR SHALLOW, CONCENTRATED FLOW

USBR (Modified Snyder) Method

The USBR (1987a) provides guidance for unit hydrograph development based on lag time using the Modified Snyder Equation, including charts for regions of the country to assist in estimating the lag time:

$$L_g = C [(L L_{ca}) / S^{0.5}]^{0.33} \quad (9-9)$$

where:

L_g = unit hydrograph lag time (hr)

C = constant (estimated as 26 times the average Manning's n value for in-channel flows with higher values for overbank flow conditions)

L = length of main watercourse (mi)

L_{ca} = length along the main water course measured from the outlet upstream to a point nearest the basin centroid (mi)

S = overall slope for longest water course (ft/mi)

9.6.1.3 Precipitation-Runoff Relationship

Generally, not all of the precipitation that falls on a watershed during a design storm becomes runoff; a portion is retained in the soil and on vegetation. Chow (1964), the USDA (1972), the NRCS (2004a), and the USBR (1973, 1987a) and other references on hydrology discuss the watershed characteristics that determine the amount of precipitation that becomes runoff. These characteristics include: (1) the types of soil and their effect on the amount of water seeping into the ground; (2) the conditions (wet, dry, snow covered or frozen) of the ground surface immediately prior to the precipitation (known as the antecedent moisture condition or AMC); (3) the type and density of vegetation; (4) the types of development, such as paved surfaces, channeling and storm sewers; and (5) dams, lakes, ponds, or swamps upstream of the site that could store water on a permanent basis, release water at a slow rate, or fail, thereby suddenly releasing large volumes of water.

9.6.1.3.1 General Rainfall Conditions

The NRCS (updating previous work when it was known as the SCS) has quantified precipitation runoff conditions for a wide range of soil, moisture and soil-cover conditions. The procedure utilizes a runoff curve number (CN) and the following equations:

$$Q = (P - I_a)^2 / (P + 0.8S) \quad (9-10)$$

$$S = (1000/CN) - 10 \quad (9-11)$$

where:

Q = direct runoff (in)

P = rainfall (in)

I_a = initial abstraction = $0.2 S$

S = maximum potential difference between P and Q at beginning of storm

Figures 9.17 and 9.18 present charts for estimating runoff from precipitation based on the above equations. Discussion of the derivation and use of these charts is presented in the NRCS (2004b) National Engineering Handbook (NEH) updating previous work by the USDA (1972). To determine the char-

acteristic CN , it is necessary to know or to estimate four watershed conditions: (1) the hydrologic soils classification, (2) the land use and surface status or treatment, (3) the hydrologic effect of the land use and status, and (4) the antecedent moisture condition (AMC).

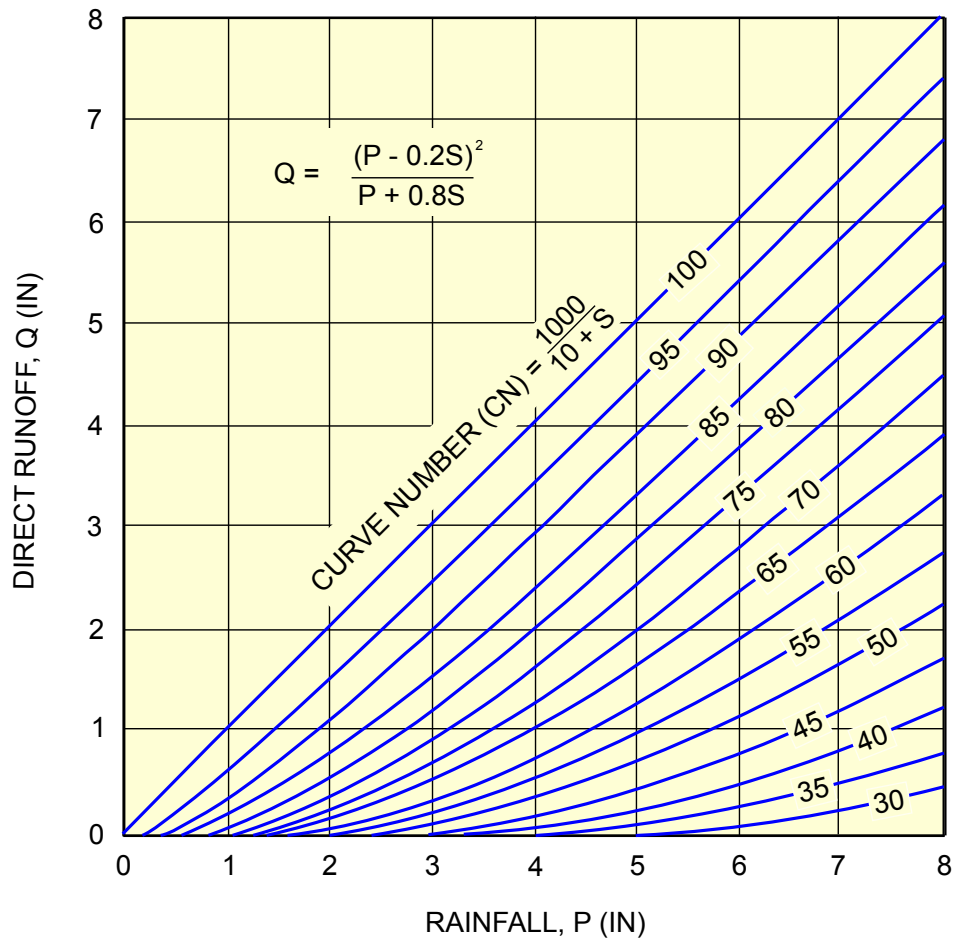

NOTE: S = POTENTIAL MAXIMUM RETENTION
AFTER RAINFALL BEGINS

(USDA, 1972)

FIGURE 9.17 DIRECT RUNOFF FOR RAINFALL LESS THAN OR EQUAL TO 8 INCHES

Traditionally, the hydrologic soil classification has been determined from county soil surveys. The soils identified in the soil surveys are categorized into four hydrologic soil groups (HSGs), as described in NEH Chapter 7 (NRCS, 2007a). The HSGs for soils of the United States are presented in Appendix A of TR55 (NRCS, 1986; Appendix A updated 1999). Groups A through D for natural soils are described below. The disturbed area soil profile for each group for watershed areas that have been affected by mining related impacts and/or urbanization is also provided.

- A. Low runoff potential – Soils having high infiltration rates even when thoroughly wetted – consisting chiefly of well to excessively drained deep sands or gravels, typically with less than 10 percent clay. These soils have a high rate of water transmission.
Soil description: Sand, loamy sand, or sandy loam.
- B. Moderately low runoff potential – Soils having moderately low infiltration rates when thoroughly wetted, consisting chiefly of moderately deep to deep soils with moder-

ately fine to moderately coarse textures, moderately well to well drained, typically with 10 to 20 percent clay. These soils have a moderate rate of water transmission.

Soil Description: Silt loam or loam.

- C. Moderately high runoff potential – Soils having slow infiltration rates when thoroughly wetted, consisting chiefly of soils with fine texture, or of soils with a layer that impedes downward movement of water, typically with 20 to 40 percent clay. These soils have a slow rate of water transmission.

Soil Description: Sandy clay loam.

- D. High runoff potential – Soils having very slow infiltration rates when thoroughly wetted. These are typically clay soils with high swelling potential, soils with a clay-pan or clay layer at or near the surface, shallow soils over nearly impervious material, and soils with a permanent high water table. These soils typically have greater than 40 percent clay and a very slow rate of water transmission.

Soil Description: Clay loam, silty clay loam, sandy clay, silty clay, or clay

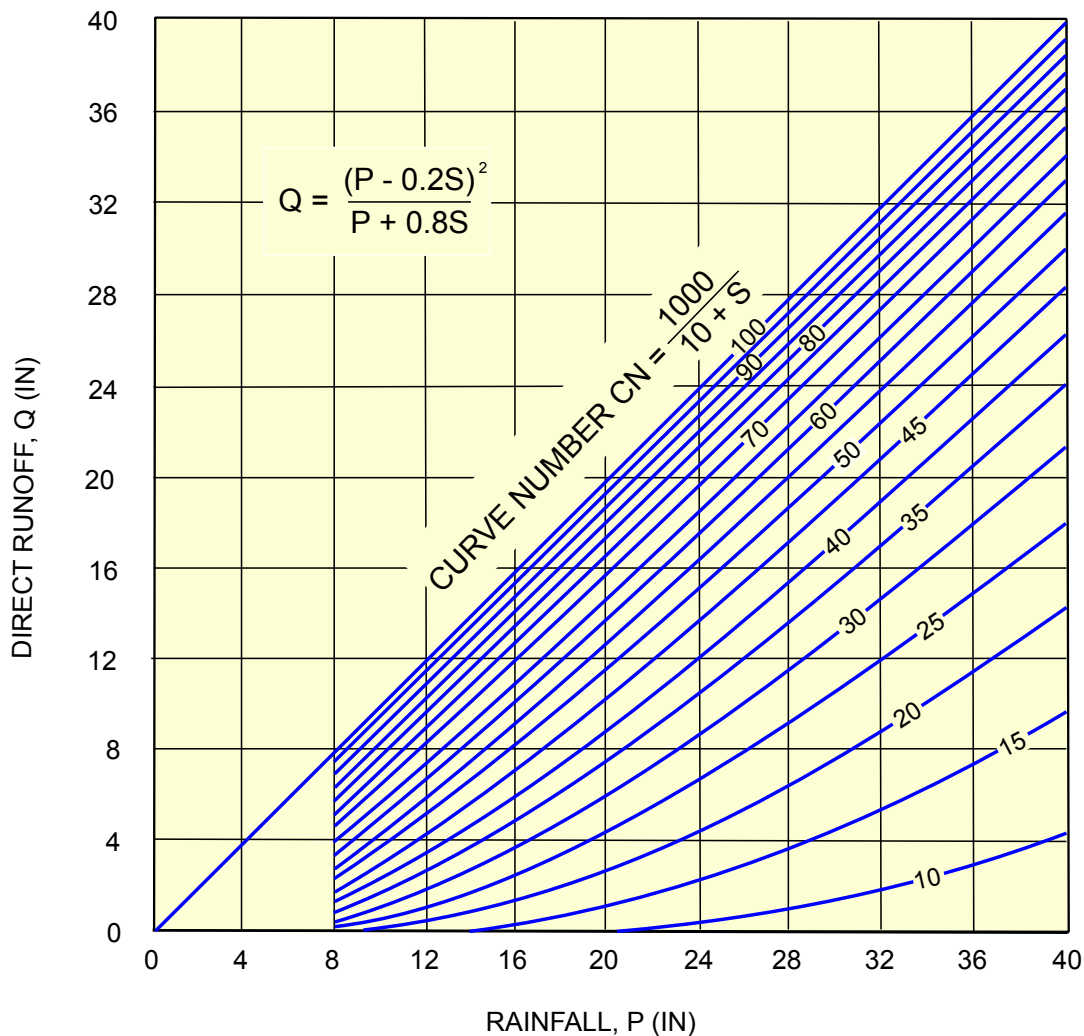

NOTE: S = POTENTIAL MAXIMUM RETENTION
AFTER RAINFALL BEGINS

(USDA, 1972)

FIGURE 9.18 DIRECT RUNOFF FOR RAINFALL GREATER THAN OR EQUAL TO 8 INCHES

The second and third watershed conditions are simply descriptions of watershed land use and surface status or treatment, such as woods or straight row, small grain crops, and the hydrologic density or impact of the land use. A general description of the hydrologic grading for soil-cover conditions typically encountered is described in conjunction with selection of the curve number (Table 9.10).

The fourth watershed condition is an index of watershed wetness referred to as the antecedent moisture condition (AMC). Antecedent moisture conditions are categorized into three groups:

- AMC-I Optimum soil conditions – soils are dry but not to the point of wilting vegetation (not recommended for design).
- AMC-II Average conditions and average value for annual floods.
- AMC-III Wet or saturated conditions associated with heavy rainfall or light rainfall and low temperatures within 5 days prior to the given storm.

The antecedent moisture condition that should be used for design of impoundment structures is either AMC-II or AMC-III. The NRCS provides procedures for estimating the antecedent moisture condition based on the 5 days of antecedent rainfall. Typically AMC-II is used for the design of drainage channels, and AMC-III is used when determining the PMF for impoundment design.

The curve number can be estimated based on the hydrologic soils group, land use, and soil-cover conditions, as presented in Table 9.10 for AMC-II. Adjustments in the estimated *CN* value can be made for AMC-I and AMC-III using Table 9.11. The NRCS (2004b) provides methods for developing composite *CN* values when there are multiple antecedent moisture conditions.

Typically, basin or subbasin averaging is performed (as in the HEC-1 model) to represent watershed areas and compute runoff hydrographs using SCS or Snyder parameters. However, distributed calculations based on mapped soil and land use conditions yield more representative runoff estimates than basin-averaged parameters, and the availability of programs such as HEC-GeoHMS that utilize GIS terrain and spatial information will efficiently facilitate this approach when digitized soils surveys are available. An overview of procedures that can be employed is presented in FERC (2001).

When calculating runoff, it is important to consider actual conditions that may be present in the watershed, including the potential effects of any impoundments. The following guidelines are applicable to refuse disposal facilities:

- For watersheds having varying runoff characteristics, subbasins should be developed or a weighted average *CN* should be computed.
- The actual impoundment is generally considered impervious and contributes 100 percent to the runoff.
- Upstream impoundments require special consideration when determining runoff. Runoff hydrographs should be routed through such impoundments to confirm their operation during the design storm and the potential impact should the structures overtop and fail.

9.6.1.3.2 Thunderstorm Rainfall Conditions

Hydrometeorological reports for the western regions of the U.S. provide guidance for analysis of thunderstorm rainfall. For the Rocky Mountain region, the USBR (1987a) identifies a local, high-intensity thunderstorm event that should be considered along with the general storm event. Charts provide guidance for selection of lag time and development of unit hydrographs.

TABLE 9.10 RUNOFF CURVE NUMBERS FOR WATERSHED COMPLEXES AND AMC-II

Cover Description		Curve Numbers for Hydrologic Soil Group				
Cover Type	Hydrologic Condition	A	B	C	D	
Cultivated Agricultural Lands ^(1, 2, 3, 4)						
Fallow	Bare soil	–	77	86	91	94
	Crop residue cover (CR)	Poor	76	85	90	93
		Good	74	83	88	90
Row crops	Straight row (SR)	Poor	72	81	88	91
		Good	67	78	85	89
	SR + CR	Poor	71	80	87	90
		Good	64	75	82	85
	Contoured (C)	Poor	70	79	84	88
		Good	65	75	82	86
	C + CR	Poor	69	78	83	87
		Good	64	74	81	85
	Contoured & terraced (C&T)	Poor	66	74	80	82
		Good	62	71	78	81
	C&T + CR	Poor	65	73	79	81
		Good	61	70	77	80
Small grain	SR	Poor	65	76	84	88
		Good	63	75	83	87
	SR + CR	Poor	64	75	83	86
		Good	60	72	80	84
	C	Poor	63	74	82	85
		Good	61	73	81	84
	C + CR	Poor	62	73	81	84
		Good	60	72	80	83
	C&T	Poor	61	72	79	82
		Good	59	70	78	81
C&T + CR	Poor	60	71	78	81	
	Good	58	69	77	80	
Close-seeded or broadcast legumes or rotation meadow	SR	Poor	66	77	85	89
		Good	58	72	81	85
	C	Poor	64	75	83	85
		Good	55	69	78	83
	C&T	Poor	63	73	80	83
Good		51	67	76	80	
Pasture, grassland, or range – continuous forage for grazing ⁽⁵⁾	Poor	68	79	86	89	
	Fair	49	69	79	84	
	Good	39	61	74	80	
Other Agricultural Lands ⁽¹⁾						
Meadow – continuous grass, protected from grazing and generally mowed for hay	–	30	58	71	78	
Brush – brush-weed-grass mixture with brush the major element ⁽⁶⁾	Poor	48	67	77	83	
	Fair	35	56	70	77	
	Good	30 ⁽⁷⁾	48	65	73	
Woods – grass combination (orchard or tree farm) ⁽⁸⁾	Poor	57	73	82	86	
	Fair	43	65	76	82	
	Good	32	58	72	79	

TABLE 9.10 RUNOFF CURVE NUMBERS FOR WATERSHED COMPLEXES AND AMC-II
(Continued)

Cover Description		Curve Numbers for Hydrologic Soil Group			
Cover Type	Hydrologic Condition	A	B	C	D
Woods ⁽⁹⁾	Poor	45	66	77	83
	Fair	36	60	73	79
	Good	30 ⁽⁷⁾	55	70	77
Farmsteads – buildings, lanes, driveways, and surrounding lots	–	59	74	82	86
Arid and Semiarid Range Lands ^(1, 10)					
Herbaceous – mixture of grass, weeds, and low-growing brush, with brush the minor element	Poor		80	87	93
	Fair		71	81	89
	Good		62	74	85
Oak-aspen – mountain brush mixture of oak brush, aspen, mountain mahogany, bitter brush, maple, and other brush	Poor		66	74	79
	Fair		48	57	63
	Good		30	41	48
Pinyon-juniper – pinyon, juniper, or both; grass understory	Poor		75	85	89
	Fair		58	73	80
	Good		41	61	71
Sagebrush with grass understory	Poor		67	80	85
	Fair		51	63	70
	Good		35	47	55
Desert shrub – major plants include saltbush, greasewood, creosotebush, blackbrush, bursage, palo verde, mesquite, and cactus	Poor	63	77	85	88
	Fair	55	72	81	86
	Good	49	68	79	84

- Note: 1. Average runoff conditions and $I_a = 0.2S$.
2. Crop residue cover applies only if residue is on at least 5 percent of the surface throughout the year.
3. Hydrologic condition is based on a combination of factors that affect infiltration and runoff, including:
(a) density and canopy of vegetative areas, (b) amount of year-round cover, (c) amount of grass or close-seeded legumes, (d) percent of residue cover on the land surface (good ≥ 20 percent), and (e) degree of surface roughness.
4. Poor: Factors impair infiltration and tend to increase runoff.
Good: Factors encourage average and better than average infiltration and tend to decrease runoff.
5. Poor: < 50 percent ground cover or heavily grazed with no mulch.
Fair: 50 to 75 percent ground cover and not heavily grazed.
Good: > 75 percent ground cover and lightly or only occasionally grazed
6. Poor: < 50 percent ground cover
Fair: 50 to 75 percent ground cover
Good: > 75 percent ground cover
7. Actual curve number is less than 30; use CN = 30 for runoff computations.
8. CN's shown were computed for areas with 50 percent woods and 50 percent grass (pasture) cover.
Other combinations may be computed from the CN's for woods and pasture.
9. Poor: Forest litter, small trees, and brush are destroyed by heavy grazing or regular burning.
Fair: Woods are grazed, but not burned, and some forest litter covers the soil.
Good: Woods are protected from grazing, and litter and brush adequately cover the soil.
10. Poor: < 30 percent ground cover (litter, grass, and brush overstory)
Fair: 30 to 70 percent ground cover
Good: > 70 percent ground cover

(ADAPTED FROM NRCS, 1986)

TABLE 9.11 RUNOFF CURVE NUMBERS (CN) FOR ANTECEDENT MOISTURE CONDITIONS

AMC II	AMC I (Not Recommended for Hydrologic Design)	AMC III
100	100	100
95	87	98
90	78	96
85	70	94
80	63	91
75	57	88
70	51	85
65	45	82
60	40	78
55	35	74
50	31	70
40	22	60
30	15	50
20	9	37
10	4	22
0	0	0

(USDA, 1972)

9.6.1.4 Channel and Impoundment Storage Characteristics

For non-impounding coal refuse disposal facilities, storage normally does not enter into the hydrologic and hydraulic analyses. Channels are generally designed for the peak runoff rate, and storage beyond the channel capacity is not a consideration. Channel and flood plain storage can be a consideration when evaluating some natural drainage systems, and hydraulic analysis software can incorporate the associated storage into the model through cross sections determined from topographic maps. For impounding disposal facilities, reservoir storage provisions are an important component of the hydraulic design and can vary between:

- The condition where the impoundment does not have reservoir storage capacity to handle any significant portion of the runoff during a storm, requiring the outflow to essentially equal the inflow rate. This condition usually requires a relatively large spillway to pass the storm inflow.
- The condition where the impoundment does have storage capacity to temporarily handle all runoff during a storm, allowing the immediate outflow discharge to be essentially zero. This condition requires an embankment high enough to safely store the storm inflow.

Most impounding disposal facilities during some period of their life fall between these extremes, and part of the runoff becomes reservoir storage and the remainder is passed as outflow. An important factor that differentiates coal refuse disposal facility impoundments from other types of impoundments is that the embankment and impoundment configurations continually change with both the

disposal of coarse refuse on the embankment and the disposal of fine refuse slurry into the impoundment. This variation must be taken into account in the hydraulic design of a disposal facility.

Several terms commonly used to describe conditions associated with an impoundment are defined below:

- Normal pool elevation – The surface elevation of water or slurry impounded by an embankment during normal disposal operations. The normal pool elevation is usually established by the decant inlet level or pump control level. With slurry impoundments, the normal pool elevation changes with time as fine refuse slurry is disposed and the decant level or pump control level is raised to successively higher elevations.
- Minimum pool elevation – The lowest surface elevation that can normally be attained. This is often the same as the normal pool elevation, but can be lower if drainage is provided by siphoning, pumping, or modifying the outlet system.
- Useful storage – The storage capacity between the normal and minimum pool elevations.
- Dead storage – The storage capacity below the minimum pool elevation that is usually filled primarily by settled slurry.
- Surcharge storage – The storage capacity between the normal pool elevation and the maximum permissible pool elevation. This capacity is intended primarily for temporary storage of runoff during storms.
- Freeboard – The difference in elevation between the dike or embankment crest (i.e., lowest portion of impoundment perimeter except for an open-channel spillway) and the impoundment water surface. Normal freeboard is the distance between the minimum embankment crest elevation and the normal pool level, as established by the lowest outlet structure used for flood routing purposes. Design-storm freeboard is the distance between the embankment crest and the maximum pool level during the design storm. The design-storm freeboard should be such that the embankment is not overtopped.

Reservoir storage volumes can be determined in several ways, all based on the topographic configuration of the impoundment area. Topographic data, generally obtained by aerial photography with 2- to 5-foot contour intervals, are suitable for most analyses. USGS topographic quadrangle maps may be used for preliminary calculations for evaluation of initial feasibility.

The normally preferred procedure for calculating the elevation-volume relationship for an impoundment is described in [Section 9.2.3](#) and is illustrated in [Figure 9.4](#). The impoundment surface area for each successive elevation contour is first determined, from which an area-elevation curve can be plotted. The storage is then computed as the area beneath the area-elevation curve at any elevation, from which the volume-elevation curve can be plotted. CADD software can be used to generate area- and volume-elevation data. Typically, both area and volume curves are presented as part of an impoundment design report or plan.

Design of impoundments for upstream or centerline construction involves placement of subsequent embankment stages within the impoundment area, which impacts reservoir storage associated with that stage of construction. Accordingly, the impoundment area-elevation and volume-elevation data for each stage of construction must allow for the effect of upstream or centerline construction.

Surcharge storage and freeboard to accommodate the design-storm runoff is required for most impoundments. In determining the surcharge storage, the volume of the settled fines above the pool level (delta deposits) must be taken into account, particularly for diked configurations where slurry is discharged over a substantial perimeter of the reservoir. The volume of the delta deposits is generally estimated based upon the position and elevation of the slurry discharge and an assumed slope of the deposit (typically between 1 and 3 percent).

Freeboard at an impoundment is provided in order to account for such factors as uncertainties in the hydrologic analyses, settlement of the embankment crest, and extreme wind effects such as wave runup. The design-storm freeboard for any impounding embankment is a function of the wave height and the wave runup conditions at the upstream face of the embankment. Guidance for the evaluation of freeboard for reservoirs is provided in USBR (1987a). Other factors that should be considered in determining freeboard requirements include: (1) frequency of the design storm, (2) duration of high water level, (3) ability to resist erosion, (4) and potential for settlement or mine subsidence. A reference for wave runup analysis is the *Coastal Engineering Manual* developed by the USACE (2002). Coal refuse impounding embankments are typically required to have a design-storm freeboard of 3 feet, which is consistent with a wind fetch of generally less than one mile.

9.6.2 Runoff Determination: Hydrograph Method

When a time history of runoff is required for final reservoir routing (Section 9.8), a runoff hydrograph must be developed. As illustrated in Figure 9.3, a hydrograph is a plot of flow rate at the point of interest versus time following storm initiation. Development of a runoff hydrograph requires the watershed runoff data discussed in the preceding section. The data are used to create unit value runoff hydrographs for small time increments within the total storm duration. A unit hydrograph models the time history of runoff flowing from the watershed at the point of interest for one time increment of precipitation. A composite runoff hydrograph can then be constructed by superimposing unit hydrographs for all increments of precipitation.

Computer programs developed by the USACE Hydrologic Engineering Center (HEC) have often been used for the hydrologic and hydraulic design of coal refuse disposal facilities. The HEC-1 Flood Hydrograph package calculates runoff hydrographs and has several optional capabilities. Use of HEC-1 for precipitation-runoff modeling requires subbasin boundary delineation, precipitation data, and runoff and routing parameters. Typically, synthetic unit hydrographs based on the SCS, Snyder or Clark methods are employed. The HEC-Hydrologic Modeling System (HEC-HMS) computer program provides advancements in several areas over the HEC-1 program, including the optional use of distributed analysis of runoff through interfacing with GIS terrain models.

The following capabilities of HEC-1 and HEC-HMS are frequently utilized during the design of coal refuse disposal facilities:

- Distributed runoff analysis using kinematic wave and Muskingum-Cunge routing, which can provide a more refined analysis of peak flows for impoundment designs incorporating open-channel spillways.
- Modeling of base flow, which may be important for large watersheds and inundation analysis.
- Channel routing using a variety of methods (e.g., Muskingum, Modified Puls, etc.) to perform inundation analysis and evaluation of impoundments in series.
- Reservoir routing (level pool routing) based on storage, elevation, and outflow rating parameters, which is a basic requirement for impounding facility design.
- Dam breach and inundation analysis for determination of the hazard-potential classification for an impounding facility and for preparation of an Emergency Action Plan.

User's Manuals for HEC-1 (USACE, 1998b) and HEC-HMS (USACE, 2000) provide documentation of their capabilities and applications. Several private companies market these programs with enhanced input and output features and also have developed similar programs with enhanced capabilities.

Regardless of the method of hydrograph development and analysis, the following computation and data validation issues should be considered:

- The computational time increment should be selected based on the lag time and precipitation data such that a smooth hydrograph is obtained. The maximum time increment of rainfall to be used in the hydrograph analysis should be the lag time divided by 5 ($L_g/5$) rounded to the next lower even number (FERC, 2001). The USACE (1998b) indicates that the time increment should be no larger than $0.29 L_g$. It can be problematic to apply this limitation to small watersheds with small lag times because some software programs limit the time increment; however HEC-HMS does not have this limitation. For impoundments that are designed to store the design storm with release through a decant pipe, the volume of runoff and peak impoundment pool level is relatively insensitive to the computation time increment.
- Determination of the lag time and time of concentration using multiple methods is a useful check of the parameter validity prior to use in hydrograph simulation. If a regional analysis is performed to estimate these parameters, performing a check on the time of concentration using the TR-55 computer program should be considered.
- The applicability of any hydrograph development method is subject to uncertainty, and verification is sometimes accomplished by investigating multiple methods (and sources of watershed parameters such as the USACE) or by reproducing a large historical flood of record from a watershed with similar characteristics. This consideration is most important for impoundments where the flood hydrograph is routed through an open-channel spillway.

9.6.3 Peak Runoff Determination – Key Parameters Method

When a complete time history of runoff is not required, estimates of the key runoff parameters can be used to determine the total runoff volume and peak runoff rate developed during a design storm. The key parameters method is useful for final design when: (1) the entire volume of runoff will be temporarily stored so that the rate of runoff does not need to be calculated or (2) the storage capacity is so small that the peak outflow rate is essentially the same as the peak runoff rate and reservoir routing is not necessary. The key parameters method is also useful for estimating approximate storage and outflow requirements during feasibility planning for various facility configurations and preliminary sizing for various hydraulic structures prior to undertaking more detailed procedures using hydrographs and reservoir routing analyses.

The USDA (1973b) published charts for the determination of total runoff volume and peak runoff rates for small volumes of runoff that can be used to estimate key parameters for design purposes. These charts provide runoff values based on watershed size, slope, and runoff curve number (CN).

Figures 9.19 and 9.20 present total runoff volume as a function of total precipitation and watershed size for runoff $CN = 70$ and $CN = 80$, respectively. The curves were derived directly from Figures 9.17 and 9.18 and do not include the minimum retentions due to soil infiltration discussed in Section 9.6.1.3. Through interpolation and extrapolation, these curves may be used to estimate total runoff volume for other CN values.

Figures 9.21 and 9.22 may be used for estimating the peak runoff rate for a range of six-hour design storms for $CN = 70$ and $CN = 80$. These figures were prepared from hydrograph analyses utilizing the recommended SCS rainfall distribution presented in Figure 9.15. Through interpolation or extrapolation, these curves can be used to estimate the peak runoff rate for other CN values between 70 and 80.

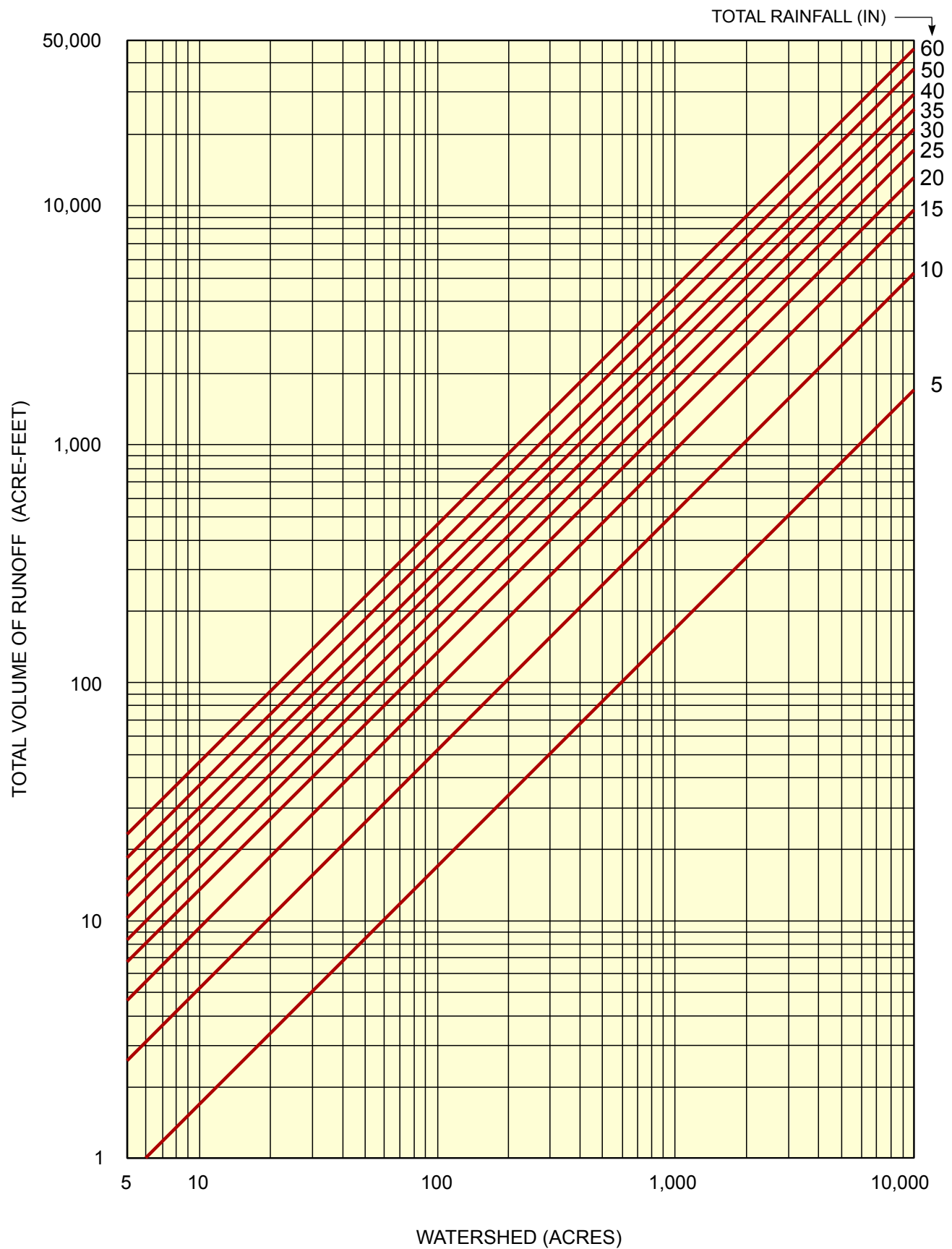

FIGURE 9.19 ESTIMATED TOTAL RUNOFF VOLUME FOR $CN = 70$

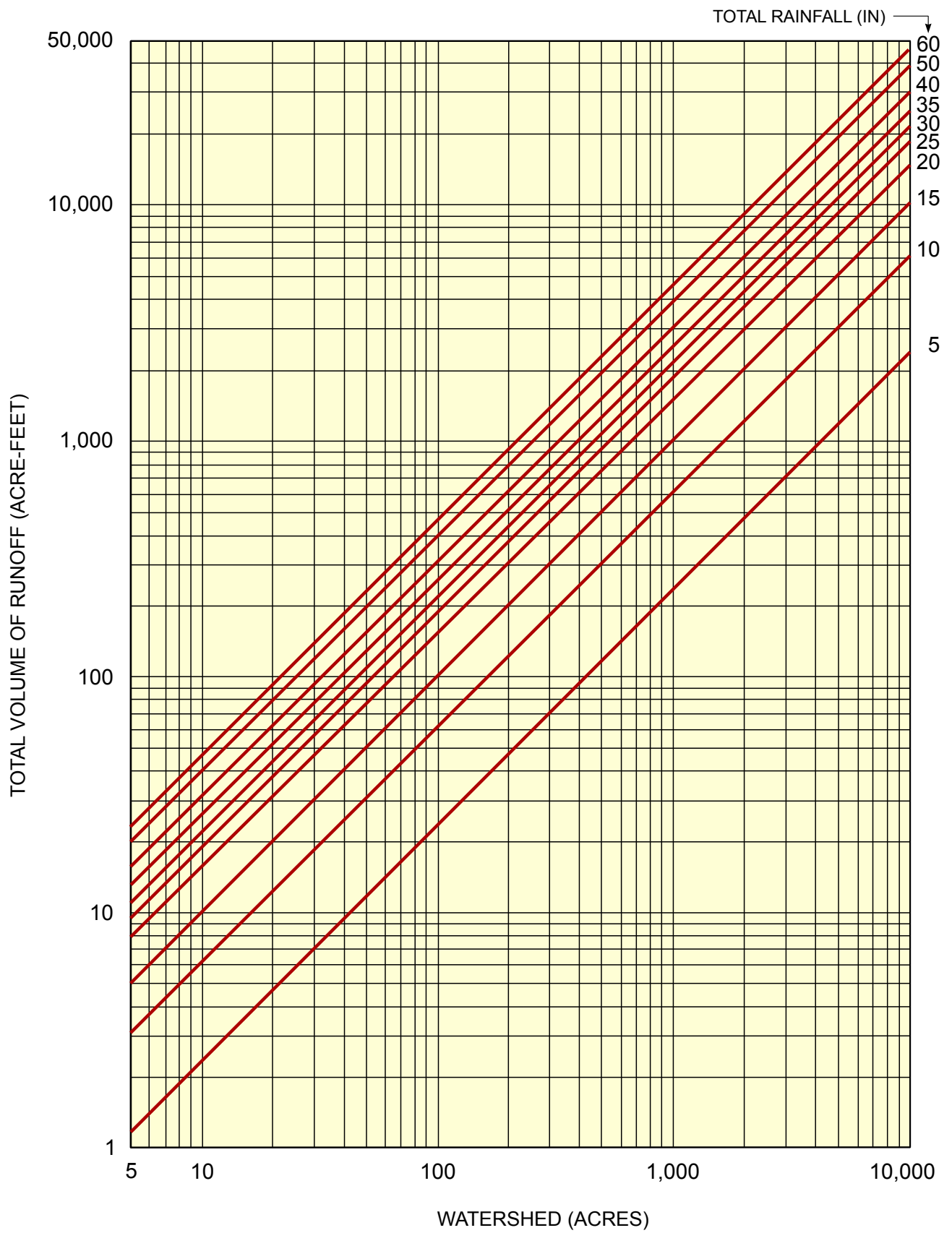

FIGURE 9.20 ESTIMATED TOTAL RUNOFF VOLUME FOR $CN = 80$

9.6.4 Runoff Determination – Rational Method

The rational method is the simplest procedure for estimating peak runoff rates and is typically used for developing design flows for minor drainage features. Originally developed by the U.S. Bureau of Public Roads and subsequently updated by the FHWA (2001), the method is usually restricted to watersheds of less than 200 acres and to storm recurrence intervals of less than 100 years. The USGS (2005) presents a review and comparison of the method with observed runoff events. Using the rational method, the peak rate of runoff is determined from the following relationship:

$$Q = CiA \quad (9-12)$$

Q = peak rate of runoff (cfs)

C = weighted average runoff coefficient

i = average precipitation intensity for a duration equal to the watershed time of concentration and the selected storm recurrence interval (in/hr)

A = watershed area tributary to the point of interest (acres)

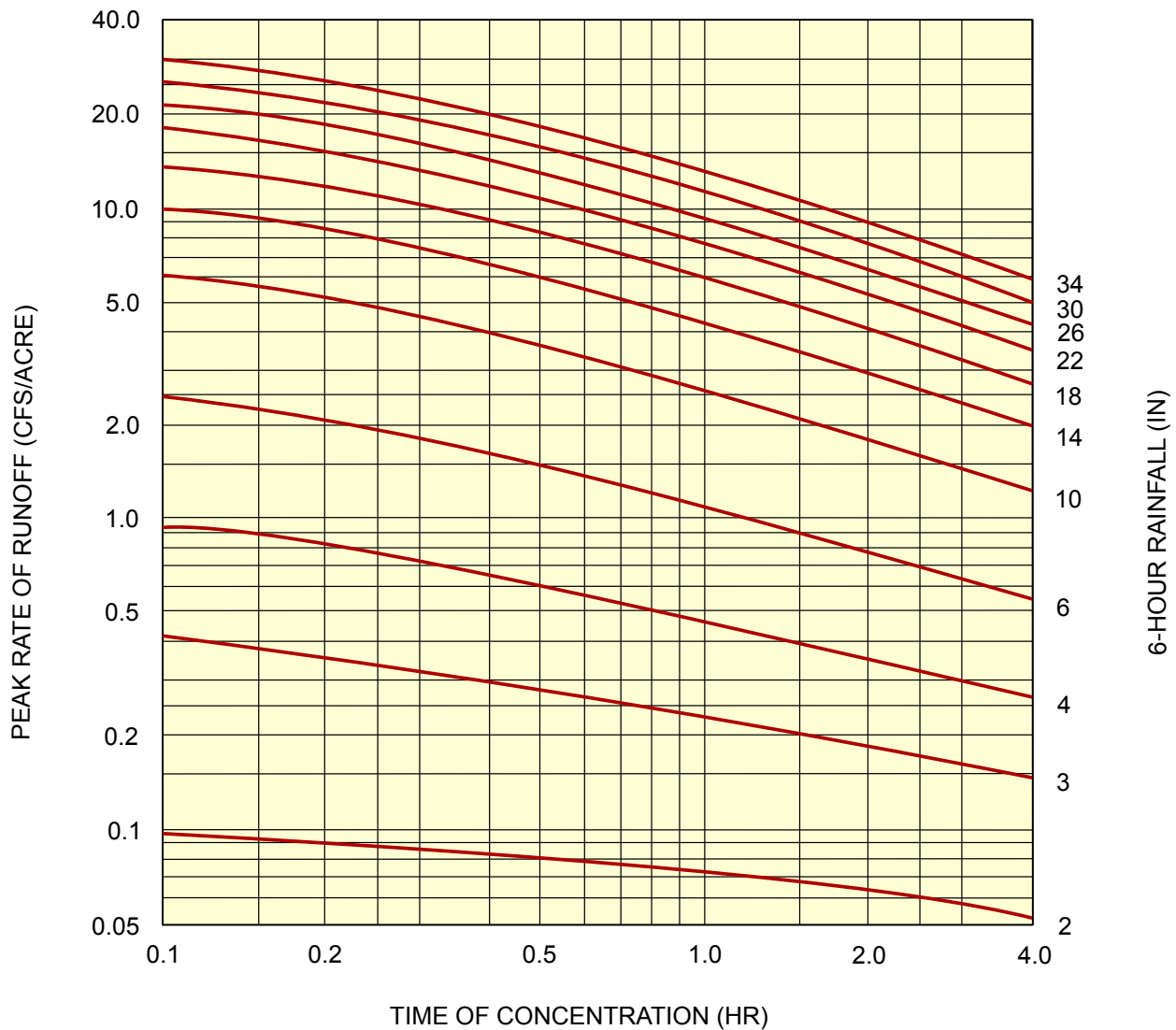

FIGURE 9.21 ESTIMATED PEAK RUNOFF RATE FOR 6-HOUR DESIGN STORM AND $CN = 70$

The runoff coefficient C can be further defined as the ratio of the rate of runoff to the rate of precipitation during the storm when all the drainage area is contributing to the runoff. The value of C can be estimated from the data provided in [Table 9.12](#). The range of the coefficients for rural areas permits some allowance for differences in slope and ground cover conditions. The lower values in the table should only be used when the watershed is flat and the surface is permeable. When the watershed exhibits multiple slope and ground cover conditions, the runoff coefficient should be determined as a weighted average based on the relative area of each of the conditions present.

The time period is equal to the time of concentration. This is the time required for the entire drainage area to be contributing to the runoff. The average precipitation intensity (i) can be determined from precipitation frequency tables presented by the National Weather Service Precipitation Frequency Data Server (web site) as an update for several states covered by Technical Paper 40. [Table 9.5](#) presents publications for precipitation frequency data.

It is emphasized that use of the rational method for determining runoff should be limited to the design of minor drainage appurtenances at a coal refuse disposal facility. An example of application of the rational method is presented in [Figure 9.23](#).

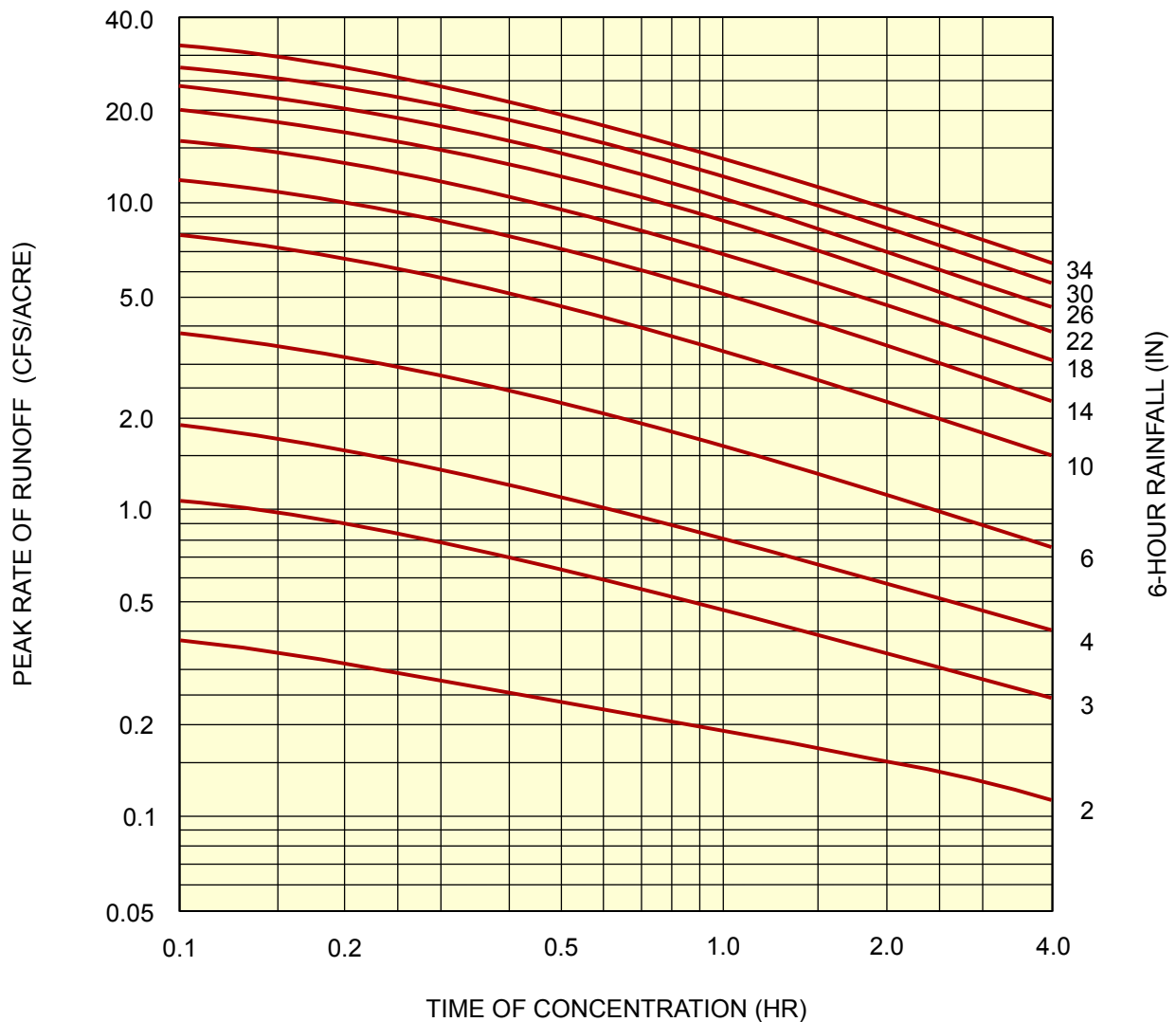

FIGURE 9.22 ESTIMATED PEAK RUNOFF RATE FOR 6-HOUR DESIGN STORM AND $CN = 80$

TABLE 9.12 RUNOFF COEFFICIENTS FOR USE IN THE RATIONAL METHOD

Rural Areas (Haan and Barfield, 1978)					
Cover Type	Terrain		Soil Texture Runoff Coefficient		
			Open Sandy Loam	Clay and Silt Loam	Tight Clay
Woodland	Flat	(0-5% slope)	0.10	0.30	0.40
	Rolling	(5-10% slope)	0.25	0.35	0.50
	Hilly	(10-30% slope)	0.30	0.50	0.60
Pasture	Flat		0.10	0.30	0.40
	Rolling		0.16	0.36	0.55
	Hilly		0.22	0.42	0.60
Cultivated	Flat		0.30	0.50	0.60
	Rolling		0.40	0.60	0.70
	Hilly		0.52	0.72	0.82

Rural Areas (FHWA, 2001)	
Cover Description	Runoff Coefficient ⁽¹⁾
Concrete or asphalt pavement	0.8 to 0.9
Asphalt macadam pavement	0.6 to 0.8
Gravel roadways or shoulders	0.4 to 0.6
Bare earth	0.2 to 0.9
Steep, grassed areas (2:1 slope)	0.5 to 0.7
Turf meadows	0.1 to 0.4
Forested Areas	0.1 to 0.3
Cultivated fields	0.2 to 0.4

Note: 1. For flat slopes or soils with high hydraulic conductivity, the lower values should be used; for steep slopes or low-hydraulic-conductivity soils, the higher values should be used.

9.7 DESIGN OF OUTFLOW SYSTEMS

This section presents the planning and design requirements for hydraulic systems to safely transport watershed runoff through, around and beyond a coal refuse disposal facility. Because the discussion is general in scope, frequent references for specific applications are made to texts and publications on hydraulic design and engineering, including: Chow (1959), USBR (1987a), Brater et al. (1996), Henderson (1966), and the USACE (1990b).

The analytical steps necessary for hydraulic design are discussed with emphasis on the important relationship of each system component to the overall requirements of the disposal facility. The discussion is presented in the following order:

- The basic considerations that determine the types of analyses to be performed.
- Introduction to basic hydraulic system components including the inlet, transport and outlet components for both open-channel and closed-conduit flow.

- Identification of special design considerations for hydraulic structures including erosion protection, effects of direction changes, cavitation and materials selection.
- Discussion of the types of principal hydraulic systems commonly encountered at coal refuse disposal facilities including spillways, decants, diversion ditches, culverts and natural streams.

9.7.1 Basic Considerations

Geometric design constraints, the coarse and fine coal production rates and the estimated runoff rate and volume influence the selection of the outflow structure(s) that can be utilized for a coal refuse disposal facility embankment or impoundment. Basic considerations in the design of hydraulic systems are noted for the following four situations:

1. No runoff storage – In this case, the hydraulic system must be designed to handle the maximum rate of runoff (i.e., outflow capacity is equal to the peak runoff rate).
2. Maximum reservoir storage – Reservoir storage is maximized with limited spillway outflow during the design storm event (Section 9.8). In this case, the designer must provide outflow capacity for all runoff in excess of the available storage. Under some conditions the optimal solution may involve total storage of the design storm runoff with delayed release through a decant system.
3. Defined surcharge storage capacity – Surcharge reservoir storage is available, but the available volume is generally limited. In this case, an iterative procedure must be employed to establish the optimum balance between reservoir storage and outflow, after which the calculated maximum outflow is used to design the hydraulic system.
4. Fixed hydraulic structure capacity – For this case, the hydraulic system capacities are fixed and the runoff that will cause failure must be determined. This situation is most often encountered when evaluating an existing facility or the flow in a natural stream.

The types of impounding and non-impounding disposal facilities and their unique characteristics have been discussed in Sections 9.3 and 9.4. The major points of these previous discussions are summarized below:

- To accommodate the progressive development and operation of coal refuse disposal facilities, intermediate-stage hydraulic drainage systems may be needed.
- All operational periods of the impoundment hydraulic systems will need to be evaluated if the progressive development of a coal refuse disposal facility impacts available reservoir storage and/or outflow capacity.
- Coal operators may be performing site development construction and, as a consequence, have certain types of equipment always available on site; the design of hydraulic system components should reflect the equipment available and operator capabilities.
- The reclaimed configuration of a coal refuse disposal facility may impact hydraulic structure design at intermediate facility stages. The final facility abandonment configuration must be taken into account in the design of intermediate stage hydraulic structures.
- The design of hydraulic structures should take into account corrosion, abrasion, erosion, weathering and maintenance requirements.

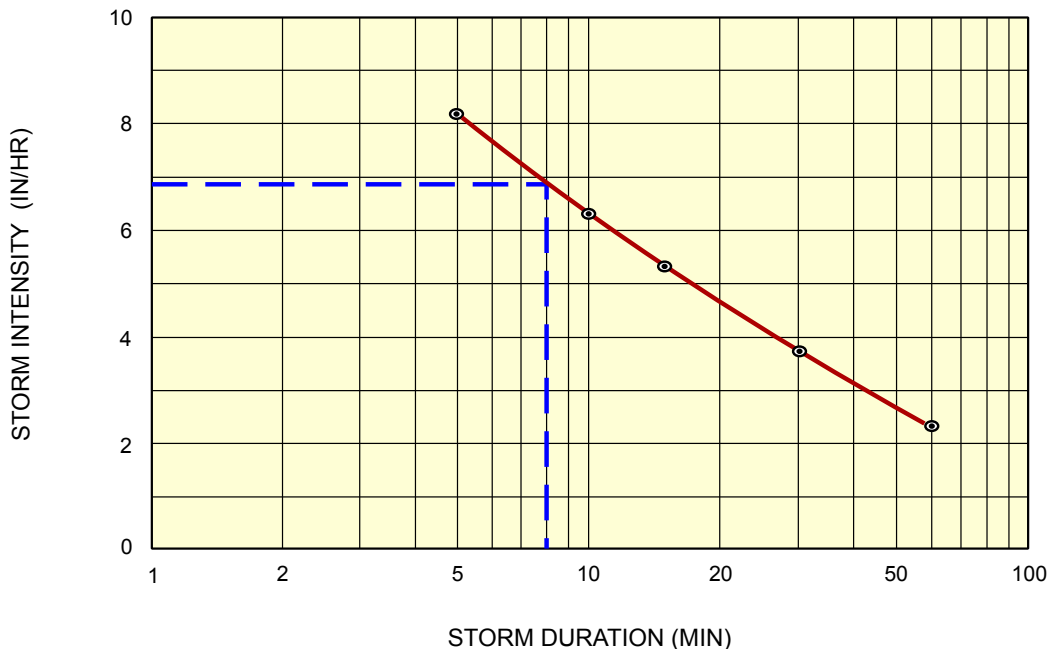

PROBLEM DETERMINE THE RUNOFF FROM A 100-YEAR RECURRENCE INTERVAL STORM FOR A STEEPLY-SLOPED, 85-ACRE WATERSHED IN ALLEGHENY COUNTY, PENNSYLVANIA. THE WATERSHED HAS THE FOLLOWING CHARACTERISTICS:

- LONGEST WATERCOURSE = 1900 FEET
- ELEVATION DIFFERENCE = 100 FEET
- TOPOGRAPHY = 60% WOODED, 30% PASTURE, 10% BARE EARTH

SOLUTION 1. DETERMINE A WEIGHTED-AVERAGE RUNOFF COEFFICIENT FROM TABLE 9.12

TOPOGRAPHY	RUNOFF COEFFICIENT
WOODED-STEEP	0.30
PASTURE-STEEP	0.70
BARE EARTH-STEEP	0.90

THEN $C = 0.60(0.30) + 0.30(0.70) + 0.10(0.90) = 0.48$

2. DETERMINE 100-YEAR INTENSITY-DURATION RELATIONSHIP FROM TP-40 (HERSHFIELD, 1961)

DURATION		PORTION OF 30-MIN RAINFALL	RAINFALL		INTENSITY
HR	MIN		IN	IN/HR	
1	60	—	2.35	2.35	
½	30	1.00	1.85	3.70	
¼	15 ⁽¹⁾	0.72	1.33	5.32	
—	10 ⁽¹⁾	0.57	1.05	6.30	
—	5 ⁽¹⁾	0.37	0.68	8.16	

NOTE: 1. FROM PAGE 5 OF TP-40.

3. DETERMINE 100-YEAR RAINFALL INTENSITY (*i*) FOR SITE

FROM FIGURE 30 OF USBR (1973), FOR *L* = 1,900 FEET AND *H* = 100 FEET, *T_c* = 8 MINUTES

FROM INTENSITY-DURATION PLOT ABOVE, *i* = 6.9 INCHES/HOUR

4. CALCULATE 100-YEAR PEAK RUNOFF FOR SITE:

$Q = C i A = 0.48(6.9)(85) = \underline{281.5 \text{ CFS}}$

FIGURE 9.23 EXAMPLE OF RATIONAL METHOD OF INFLOW CALCULATION

9.7.2 Hydraulic System Components

Hydraulic systems that transport runoff through, around and beyond coal refuse disposal facilities have three basic components:

1. The inlet, where flow enters the system.
2. The transport or conveyance section that carries flow between the inlet and outlet.
3. The outlet, where water is discharged in an acceptable manner.

The rate of flow can be controlled by any portion of the hydraulic system by varying the size, location, elevation, slope, shape or configuration of these three components. Interrelationships between the inlet, the transport section and the outlet must be evaluated as part of hydraulic system design. An important design consideration when optimizing the balance between storage and outflow ([Section 9.8](#)) is that the maximum head of water needed to develop the desired rate of outflow does not exceed the maximum permissible impoundment pool elevation at any time during the life of the structure.

The following sections detail important aspects of each hydraulic system component, identifying appropriate design procedures and discussing the role of each component in various types of hydraulic systems.

9.7.2.1 Inlets

The inlet to a hydraulic system can: (1) simply direct flow to the transport section or (2) regulate the rate of flow (volume and/or velocity) to the transport section.

In the first case, the inlet must have a larger flow capacity than the transport section so that the inlet does not restrict the flow, and the inlet must be arranged such that water cannot bypass the transport section. Often the design requirement for regulating the amount of flow passing into the transport section is associated with the entrance to a decant system ([Section 9.7.4.1](#)) or to a spillway ([Section 9.7.4.2](#)). In these cases, a primary design criterion is the relationship between the height of water above the controlling elevation of the inlet, referred to as head H and the discharge Q . Typical head-discharge curves for decant-conduit and spillway systems are presented in [Figure 9.24](#).

As shown in [Figures 9.25](#) and [9.26](#), most inlets have a form of weir control, and the basic equation for the associated flow is:

$$Q = CLH^{3/2} \quad (9-13)$$

where:

- Q = discharge or rate of flow (cfs)
- C = a coefficient that depends on the shape of the channel entrance and the head on the structure
- L = the effective length of the entrance crest (ft)
- H = the total head on the entrance crest (ft)

Equation 9-13 can be used to determine flow rates over both broad- and sharp-crested weirs. Broad-crested weirs are characterized by small H/B ratios, where H and B are as defined in [Figure 9.25a](#). An unrestricted channel entrance, such as shown in [Figure 9.25c](#), can sometimes be described as a broad-crested weir. The discharge coefficient C for broad-crested weirs is a function of the weir geometry and

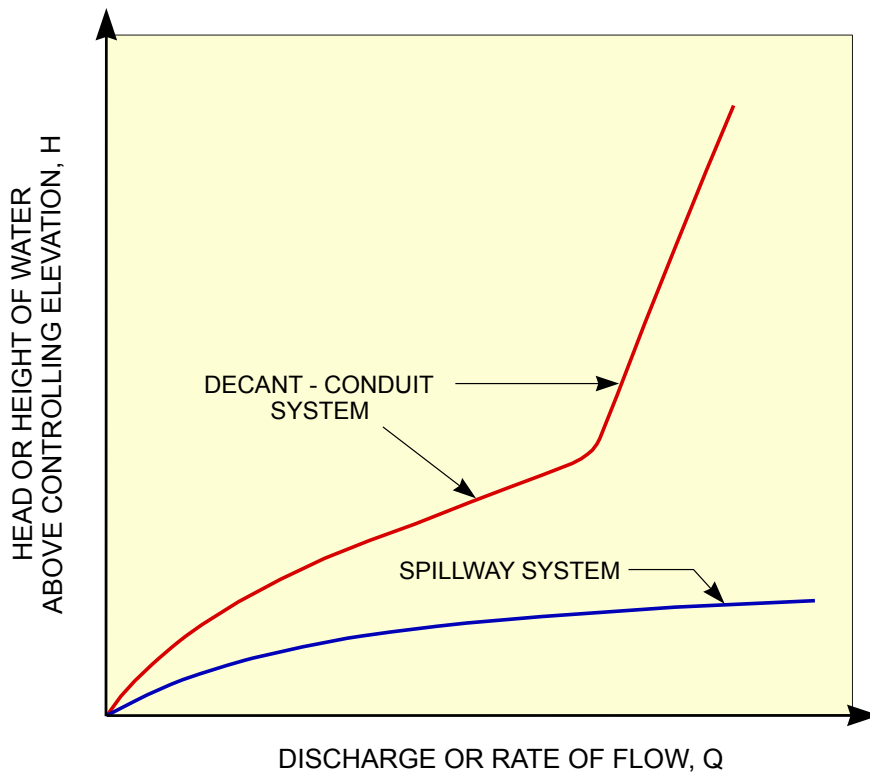

FIGURE 9.24 TYPICAL HEAD-DISCHARGE CURVES FOR HYDRAULIC SYSTEMS

approach conditions, as discussed in texts on hydraulics such as Brater et al. (1996), Chow (1959), and Henderson (1969). The value of the weir coefficient is generally about 3.0, but varies based on the weir configuration. Hydraulic analysis of the discharge and depth of flow through a broad-crested weir, including charts for determining flow profiles, is presented in USDA Technical Release 39 (1968).

Discharge coefficients for sharp-crested weirs, such as the decant inlets shown in Figure 9.26, are related to the weir height and the hydraulic head. The value of C can be determined from the revised Rehbock formula (Brater et al., 1996), which has been verified in tests performed by the USBR:

$$C = 3.22 + 0.44 (H/P) \quad (9-14)$$

where:

H = hydraulic head (ft)

P = height of weir (ft)

A range of weir coefficients is presented in Figure 9.25b for an ogee crest. The designer is referred to the USBR (1987a) for a more detailed presentation of discharge coefficients for ogee crests. The USACE (1990b) presents design methods and discharge coefficients for elliptical (ogee) spillways and spillways with free outfall.

With increasing head on a decant or spillway conduit, the weir will become submerged and orifice flow conditions may govern the head-discharge relationship, or pressure flow may prevail depending on the transport section. Under orifice flow, the control section is located within the conduit or throat of the transition between the inlet and transport section, below the crest of the vertical intake shown in Figure 9.26a. USBR (1987a) presents procedures for determining the head-discharge rela-

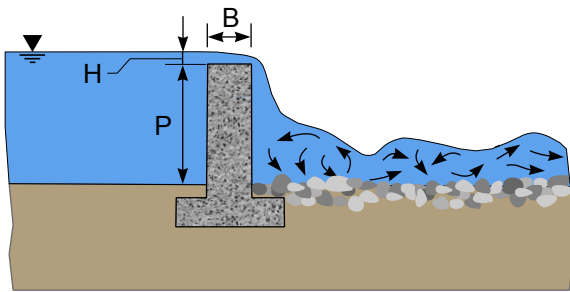

9.25a RECTANGULAR WEIR

$Q = C L H^{1.5}$
 C = WEIR COEFFICIENT
 L = LENGTH OF CREST
 H = HEAD ON CREST
 B = BREADTH OF CREST
 P = HEIGHT OF WEIR

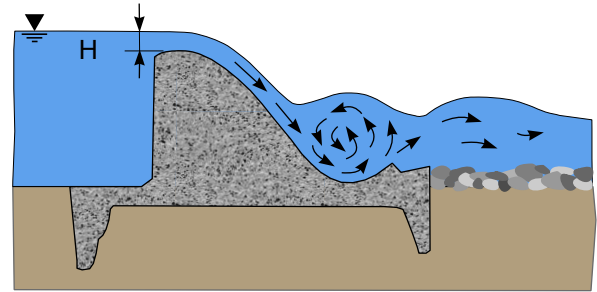

9.25b OGEE CREST DAM

$Q = C L H^{1.5}$
 C = 3.80 TO 3.95
 L = LENGTH OF CREST
 H = HEAD ON CREST

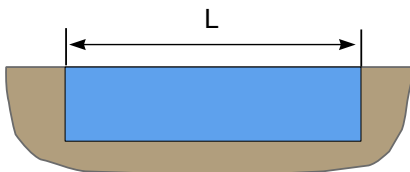

SECTION A - A
 RECTANGULAR FLOW SECTION

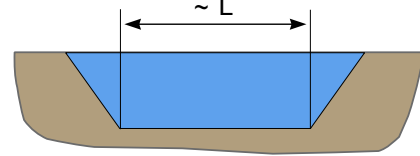

SECTION A - A
 TRAPEZOIDAL FLOW SECTION

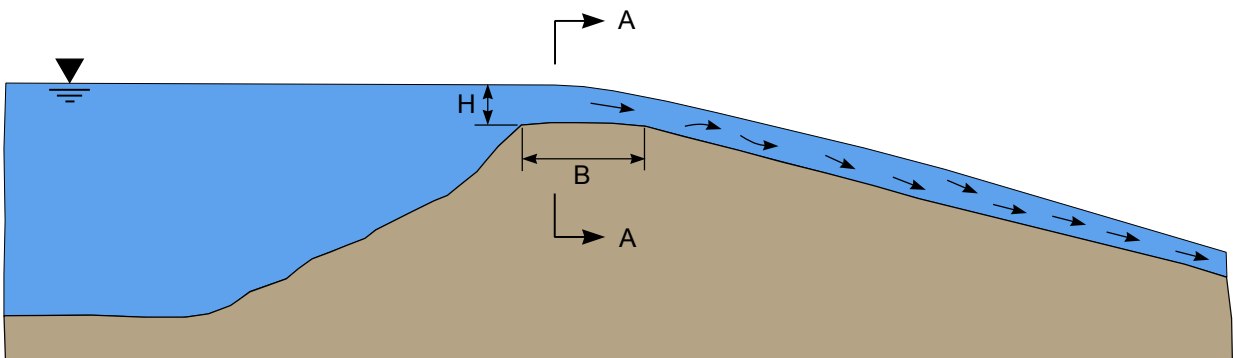

9.25c UNRESTRICTED CHANNEL ENTRANCE

FOR STEEP CHANNEL SLOPE $Q = C L H^{1.5}$ WHERE C = 3.0

FOR MILD CHANNEL SLOPE Q DEPENDS ON CHANNEL GEOMETRY AND MAY BE CONTROLLED BY DOWNSTREAM CONDITIONS

FIGURE 9.25 SPILLWAY APPROACH CHANNELS

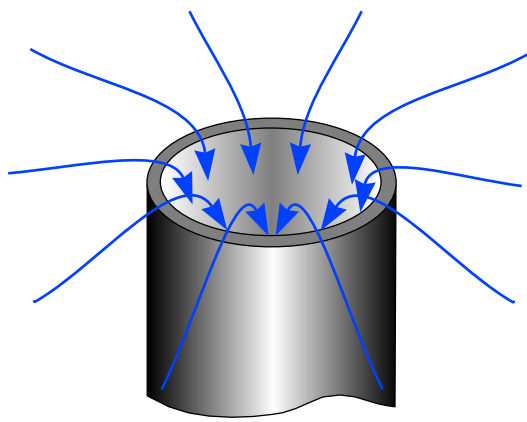

9.26a CIRCULAR DROP INLET PIPE

$$Q = C\pi DH^{1.5}$$

C = WEIR COEFFICIENT

D = DIAMETER OF DROP-INLET PIPE

H = HEAD AT TOP OF DROP-INLET PIPE

$$Q = 2C(W+L)H^{1.5}$$

C = WEIR COEFFICIENT

W = WIDTH OF DROP INLET

L = LENGTH OF DROP INLET

H = HEAD AT TOP OF DROP INLET

NOTE: 1. FLOW IS SHOWN ON FOUR SIDES OF DROP INLET. IF PARTIALLY OBSTRUCTED, THE ACTUAL FLOW LENGTH SHOULD BE USED.

2. THE INLET CONTROL FLOWS ARE ONLY APPLICABLE PRIOR TO PRESSURIZED PIPE FLOW.

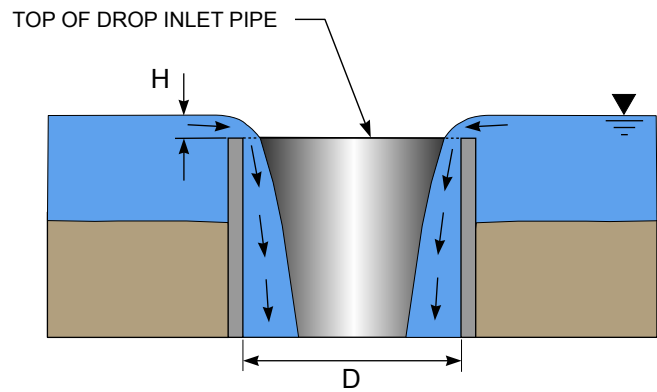

TWO-DIMENSIONAL CROSS SECTION OF CIRCULAR DROP-INLET PIPE

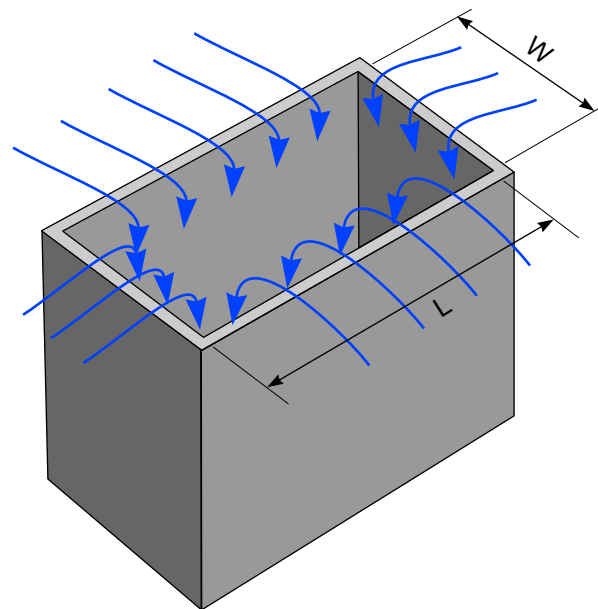

9.26b RECTANGULAR DROP INLET

FIGURE 9.26 DROP-INLET DECANT SYSTEMS

relationship for conduit spillways. For small-diameter conduits, as typically found with many decant structures, the head-discharge relationship under orifice flow control can be estimated as follows:

$$Q = CA(2gH)^{0.5} \quad (9-15)$$

where:

C = coefficient of discharge (dependent on configuration of conduit opening)

A = cross-sectional area of conduit (ft²)

g = gravitational acceleration (ft/sec²)

H = total head on the conduit entrance (ft)

For orifice flow, the coefficient of discharge C for vertical, circular decant systems is typically about 0.6 for square-edged conditions. Brater et al. (1996) and Haan and Barfield (1978) present the results of studies of varying orifice conditions and associated coefficient of discharges for various inlet shapes.

9.7.2.2 Transport Sections

The transport or conveyance section of a hydraulic system conveys flow from the inlet to the outlet. The two basic types of flow in transport sections are:

1. Open-channel flow – Gravity flow of water through an open channel where the flow depth and velocity depend upon the cross section, surface material and channel slope, and possibly also upon interrelationships with the inlet and outlet. Open-channel flow is typical for spillway channels, diversion ditches and natural streams, but may also apply to a less-than-full culvert or a decant conduit.
2. Pressure flow – Pressure flow through a closed conduit or pipe where the flow capacity depends upon the inlet and outlet conditions, the pressure head on the conduit and the conduit size and material. This type of transport section is common to decant systems.

Flow within a spillway system, as illustrated in [Figure 9.25a](#) and [9.25b](#), where the transport section is simply the free-fall flow over a weir or high-velocity flow over an ogee crest, are not generally encountered at coal refuse disposal facilities. The designer is referred to the USBR (1987a) and the USACE (1990b) for this type of hydraulic design

9.7.2.2.1 Open-Channel Flow

Figure 9.27 illustrates several types of open-channel cross sections. The flow rate Q for each channel is the product of the average flow velocity V and flow area A :

$$Q = VA \quad (9-16)$$

where:

- Q = flow rate (cfs)
- V = average velocity of flow (ft/sec)
- A = cross-sectional area of flow (ft²)

The flow area is a function of the flow depth which, along with the required freeboard, establishes the required height of the channel. Velocity is important because it is directly related to the potential for erosion, cavitation and energy dissipation. Normally, the required flow area is determined first, because the channel geometry is often controlled by the refuse disposal facility and site configurations and the desire to have uniform channel cross sections to simplify construction.

Methods for the analysis of open-channel flow and procedures for calculating depth of flow at any point along a channel are available in many texts, including Brater et al. (1996), Henderson (1969), and Chow (1959). The FHWA (1961) presents tables and charts for determination of open-channel flow parameters in prismatic channels. Computer software for determining steady-state and transient flow conditions in open channels is also readily available. Accordingly, the following discussion of design and analysis considerations relates to flow regulation and the identification of specific conditions or features encountered at coal refuse disposal facilities.

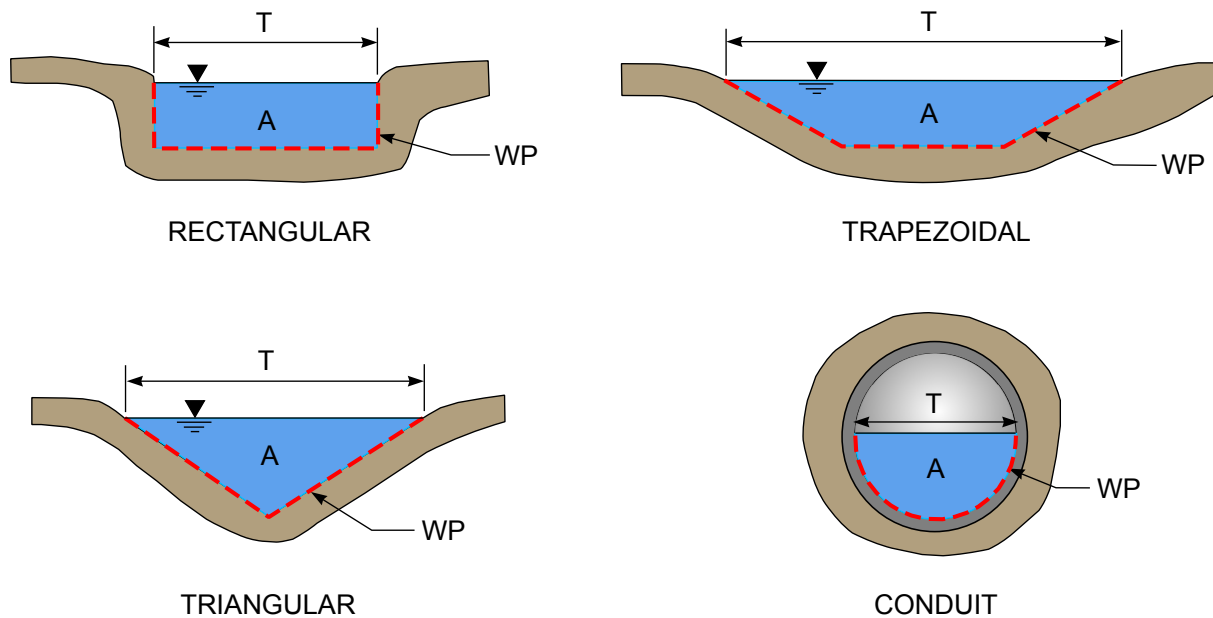

$$\text{HYDRAULIC RADIUS (R)} = \frac{\text{AREA (A)}}{\text{WETTED PERIMETER (WP)}}$$

$$\text{HYDRAULIC DEPTH (D)} = \frac{\text{AREA (A)}}{\text{TOPWIDTH (T)}}$$

FIGURE 9.27 OPEN-CHANNEL CROSS SECTIONS

Four possible flow (and depth) conditions must be considered in the design of an open channel. These are: (1) critical depth, (2) depth at subcritical flow, (3) depth at supercritical flow, and (4) normal depth. The point at which open-channel flow passes through the critical depth is a regulating condition of flow. Hereafter, the point where this occurs is referred to as a control point or location regulating the flow rate. The depth of flow at a control point may also be referred to as the control depth. Several examples illustrating these basic flow conditions are presented in [Figure 9.28](#). Additional explanation of these conditions is provided in the following:

1. **Critical depth** – The critical depth of flow in an open channel is the depth at which flow occurs with the minimum specific energy, defined as the minimum depth y plus the velocity head ($V^2/2g$) for the channel. At the critical state of flow, the velocity head is equal to half the hydraulic depth D , as defined in [Figure 9.27](#). Chow (1959) and FHWA (1961) provide detailed discussion of the critical depth and minimum specific energy. For design, the critical depth is normally calculated for comparison to the actual depth to determine if the actual flow condition is subcritical or supercritical. [Figure 9.29](#) presents curves for determining the critical depth for trapezoidal and circular channels. Except at flow control points, design at or close to critical depth should be avoided in order to prevent the occurrence of unstable flow regimes.
2. **Depth at subcritical flow** – For subcritical flow the channel slope is milder than that associated with critical flow, and the flow velocity is relatively low. Channel slopes with subcritical flow are called subcritical slopes. For subcritical flow, the control point will be downstream.

3. Depth at supercritical flow – For supercritical flow the channel slope is steeper than that associated with critical flow and the flow velocity is relatively high. Channel slopes with supercritical flow are called supercritical slopes. For supercritical flow, the control point will be upstream. If it is important that water be carried away from the inlet section without a possible back up, it may be desirable to design for a supercritical flow condition for a portion or all of the length of the channel. However, this may result in high flow velocities, and special attention will have to be given to factors such as erosion, flow at direction changes and energy dissipation at the discharge point. Most coal refuse disposal facilities have a large elevation difference between the embankment crest and downstream toe, and this generally results in some section of the channel between these two points having a supercritical flow condition.
4. Normal depth – Normal flow depth occurs when the energy increase during elevation drop is exactly balanced by friction losses along a channel. When this occurs, the flow depth and velocity in a channel of constant cross section and slope will remain constant. Open-channel flow naturally tends toward the normal depth condition, but for short channel lengths it often does not reach the normal condition. Because normal depth is easily determined, it is the flow condition most often used during preliminary hydraulic analyses to establish whether or not the selected channel slope is feasible (as limited by geotechnical or structural conditions).

The Manning equations are used to estimate the velocity and depth of flow for a given flow rate and channel configuration. These equations are:

$$Q = \frac{1.49}{n} A R^{0.67} S^{0.5} \quad (9-17)$$

$$V = \frac{1.49}{n} R^{0.67} S^{0.5} \quad (9-18)$$

where:

- Q = flow rate (cfs)
- V = average velocity of flow (ft/sec)
- A = cross-sectional area of flow (ft²)
- R = hydraulic radius (ft)
- S = slope of the channel (ft/ft)
- n = Manning's coefficient of channel roughness

The depth determined from the Manning formula is normal depth. The term R is the hydraulic radius of the flow and is equal to the area of flow A divided by the wetted perimeter WP . The wetted perimeter for several types of cross sections is shown in [Figure 9.27](#). Values of Manning's coefficient of channel roughness n are listed in [Table 9.13](#). An extensive presentation of n values for a wide variety of channels is provided in Chow (1959) and FHWA (1961). Depending upon the effective roughness of the surface, n can range from as high as 0.2 for channels with dense brush growth and many obstructions to as low as 0.01 for smooth-finish, concrete-lined channels.

Since the cross-sectional area A and hydraulic radius R are both functions of flow depth, an iterative procedure is required to determine a normal depth that satisfies the Manning equations. Commercially available software can be used to determine flow depth, velocity, critical depth and slope, and various open-channel design parameters (e.g., HEC-RAS and privately marketed similar programs).

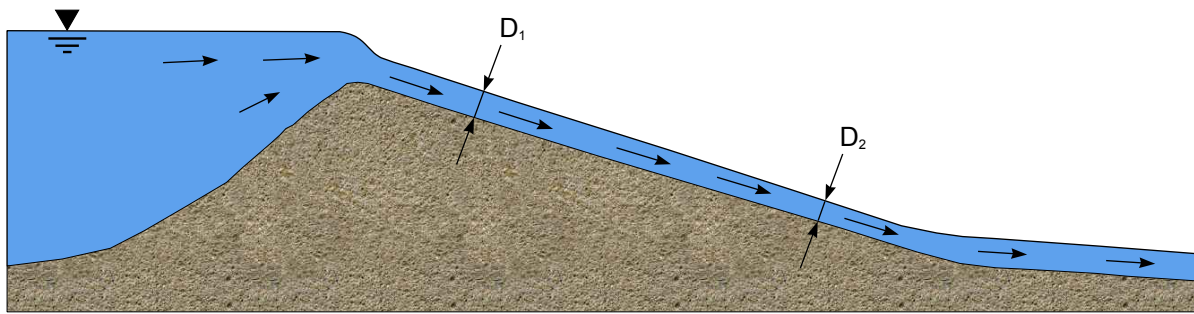

9.28a STEEP SLOPE (SUPERCRITICAL FLOW)

1. D_1 IS CONTROLLED BY INLET CONDITIONS
2. D_2 IS CONTROLLED BY D_1
3. D_2 APPROACHES NORMAL DEPTH

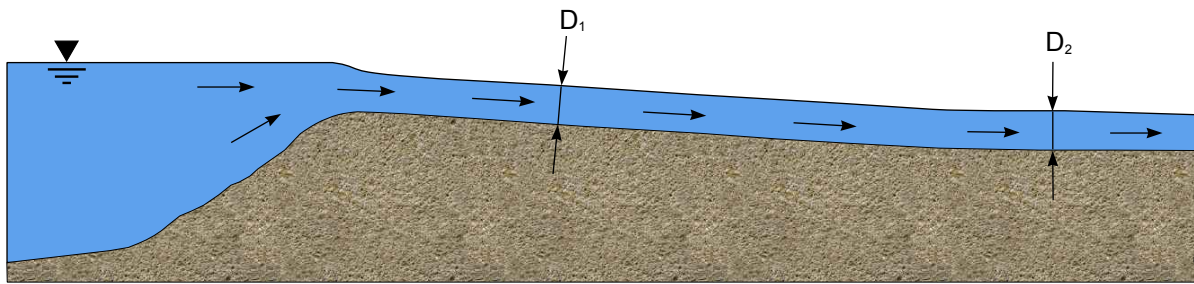

9.28b MILD SLOPE (SUBCRITICAL FLOW)

1. D_2 IS CONTROLLED BY DOWNSTREAM CONDITIONS
2. D_1 IS CONTROLLED BY D_2
3. D_1 APPROACHES NORMAL DEPTH

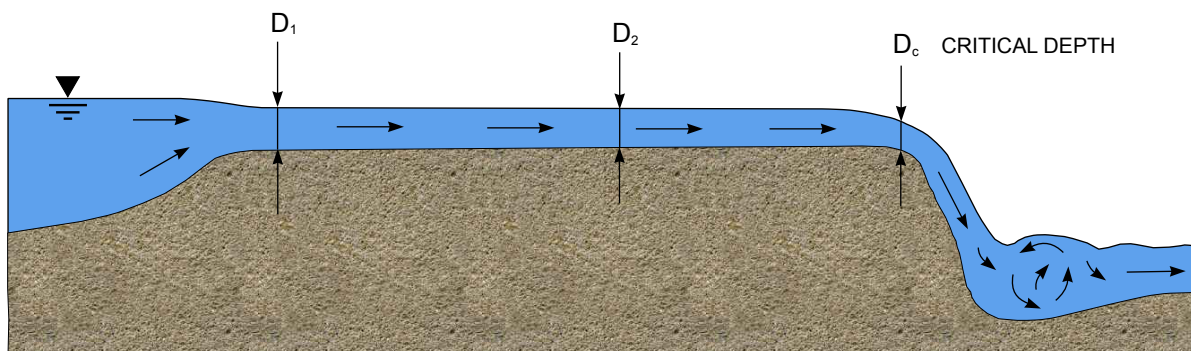

9.28c MILD SLOPE WITH STEEP DROP

1. CONTROL IS AT THE POINT WHERE CRITICAL DEPTH (D_c) OCCURS
2. D_c IS A FUNCTION OF CHANNEL SHAPE AND FLOW (Q)
3. D_2 AND D_1 ARE CONTROLLED BY D_c

FIGURE 9.28 CHANNEL FLOW CONDITIONS

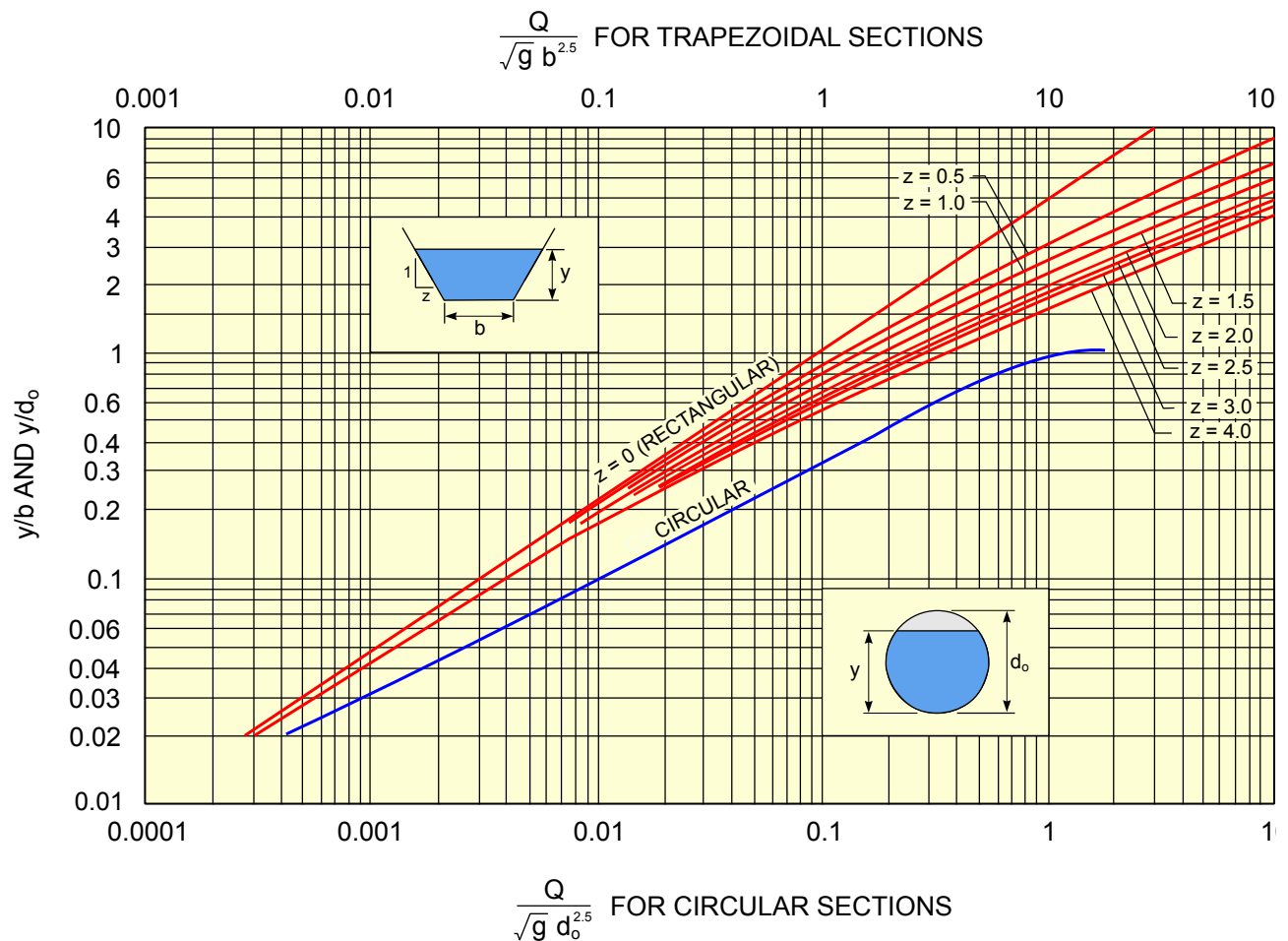

FIGURE 9.29 CRITICAL DEPTH FOR TRAPEZOIDAL AND CIRCULAR SECTIONS

Many commercially manufactured erosion control products have been developed to resist potential erosion. These products include vegetation control mats, interlocking concrete blocks, concrete mat systems, cellular confinement mats, etc. The Manning's n value for these erosion control products is typically provided by the manufacturer.

An experienced designer can determine if the normal depth of flow from the Manning equations is sufficient for determining flow conditions for final design. Detailed analyses of water surface profiles may be necessary, particularly when depths associated with changes in channel configuration, erosion protection and slope may be required. In these situations, the change in water surface elevation (water surface profile) due to velocity head and channel losses should be determined. The normal depth does not adequately describe conditions at the ends or transitional zones in the transport section. For example, where a channel with supercritical slope changes to a short length of channel with subcritical slope (e.g., benches on an embankment face), the designer must determine if the depth in the subcritical section will create a "hydraulic jump," and calculation of the flow profile along the length of the open channel often must be made. Another instance where flow profiles must be determined is when establishing a spillway rating curve (stage-discharge curve) for an approach channel between the impoundment and an open-channel spillway weir (control section) or when subcritical flow is present downstream of or within the spillway channel. Procedures for analyzing such channel sections are presented in many references on open-channel flow, including Brater et al. (1996), Henderson (1969) and Chow (1959). The FHWA (2006), USBR (1987a) and the USDA (1956) present methods and charts for determining the depths and other parameters associated with hydraulic jumps in open channels. If a hydraulic jump occurs, the channel depth must be sufficient to contain the sequent flow depth that will develop.

TABLE 9.13 MANNING'S COEFFICIENTS OF CHANNEL ROUGHNESS

Constructed Channel Condition	Values of n		
	Minimum	Maximum	Average
Earth channels, straight and uniform	0.017	0.025	0.022
Dredged earth channels	0.025	0.033	0.028
Rock channels, straight and uniform	0.025	0.035	0.033
Rock channels, jagged and irregular	0.035	0.045	0.045
Concrete lined, regular finish	0.012	0.018	0.014
Neat cement lined	0.010	0.013	0.011
Grouted rubble paving	0.017	0.030	0.025
Corrugated metal	0.023	0.025	0.024
Natural Channel Condition	Value of n		
Smoothest natural earth channels, free from growth with straight alignment	0.017		
Smooth natural earth channels, free from growth, little curvature	0.020		
Average, well-constructed, moderate-sized earth channels	0.0225		
Small earth channels in good condition or large earth channels with some growth on banks or scattered cobbles in bed	0.025		
Earth channels with considerable growth, natural streams with good alignment and fairly constant section, or large floodway channels well maintained	0.030		
Earth channels considerably covered with small growth or cleared but not continuously maintained floodways	0.035		
Mountain streams in clean loose cobbles, rivers with variable cross section and some vegetation growing in banks, or earth channels with thick aquatic growths	0.050		
Rivers with fairly straight alignment and cross section, badly obstructed by small trees, very little underbrush or aquatic growth	0.075		
Rivers with irregular alignment and cross section, moderately obstructed by small trees and underbrush	0.100		
Rivers with fairly regular alignment and cross section, heavily obstructed by small trees and underbrush	0.100		
Rivers with irregular alignment and cross section, covered with growth of virgin timber and occasional dense patches of bushes and small trees, some logs and dead fallen trees	0.125		
Rivers with very irregular alignment and cross section, many roots, trees, large logs, and other drift on bottom, trees continually falling into channel due to bank caving	0.200		

(USBR, 1987a)

9.7.2.2.2 Pressure Flow

Closed conduits are used as the transport section for two types of hydraulic systems. When the flow enters the conduit with a nearly horizontal approach, the system is called a culvert. When the flow enters the conduit through a steeply inclined or vertical drop inlet, the system is called a decant. These two types of hydraulic systems are illustrated in [Figure 9.30](#).

When flowing full, both types of closed-conduit systems behave in essentially the same manner, and their capacity can be determined from pipe flow analyses. However, the systems differ significantly in behavior during conditions leading up to the full-flow condition. The following paragraphs discuss the hydraulics of culvert systems in detail. The hydraulic behavior of decant systems is then presented with particular emphasis on the differences between decant and culvert systems.

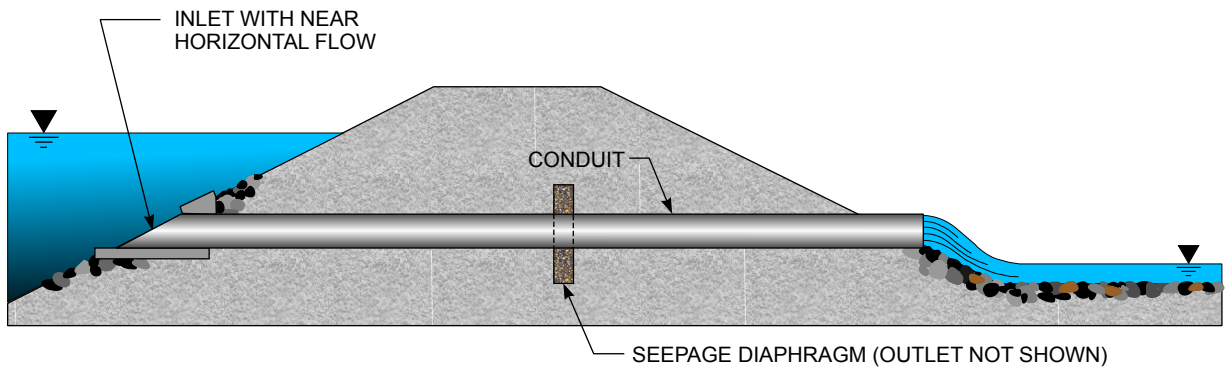

9.30a CULVERT SYSTEM

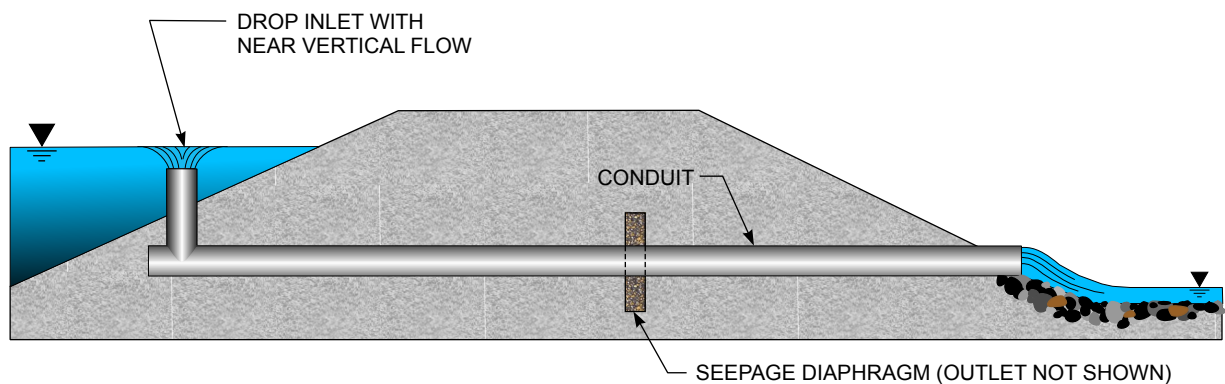

9.30b DECANT SYSTEM

FIGURE 9.30 CLOSED-CONDUIT HYDRAULIC SYSTEMS

Culvert Conduits

A culvert is a pipe placed beneath an embankment with an entrance that is horizontal or slightly inclined to the direction of flow. A culvert can be prefabricated or cast-in-place and the cross section can be round, square, rectangular, oval or arched. Factors that control the flow in a culvert are slope, size, shape, length and roughness (material) and inlet and outlet configuration. The combined effects of these factors determine the hydraulic control location, which in turn determines whether the culvert flows partly or completely full and establishes the head-discharge relationship. As with open-channel flow, the slope of the culvert may be mild or steep, resulting in subcritical or supercritical flow conditions. For either slope condition, the control point may be either at the inlet or the outlet, depending on the system geometry and the upstream and downstream head conditions. [Figures 9.31](#) and [9.32](#) illustrate the various factors that affect flow in culverts.

The control point for a culvert on a mild slope flowing partly full will usually be at the outlet if the inlet is not submerged. The flow ordinarily will be subcritical, and the discharge may be predicted according to the open-channel flow procedures discussed above. If the outlet discharges freely, the flow at that point will pass through critical depth (Figure 9.31a). As the inlet becomes submerged, the control point moves downstream within the culvert. The flow could be supercritical just inside the culvert if limited submergence is sustained ($H/D \sim 1.2$). As submergence of the entrance increases ($H/D > 1.2$, Figure 9.31b), or the culvert is sufficiently long, or the elevation of the downstream back-water is sufficiently high, full pipe flow occurs with control at the downstream end of the conduit.

PART FULL FLOW - INLET NOT SUBMERGED

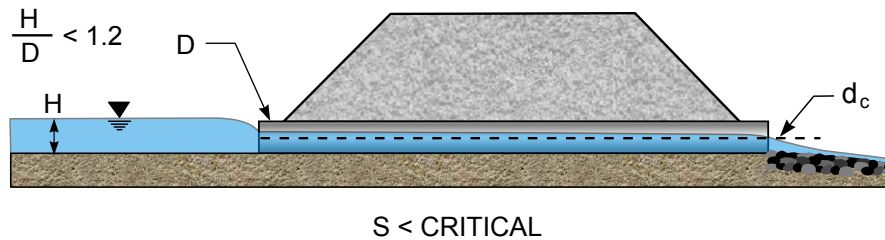

9.31a MILD SLOPE - SUBCRITICAL FLOW: CONTROL AT CRITICAL DEPTH AT OUTLET

FULL FLOW - INLET SUBMERGED

9.31b MILD SLOPE - CONTROL AT OUTLET: EFFECTIVE HEAD = $H_t - \Sigma \text{LOSSES}$

FIGURE 9.31 TYPICAL FLOW CONDITIONS – CULVERT CONDUITS ON MILD SLOPES

Most coal refuse disposal facility decant systems are less than 36 inches in diameter with a length of a few hundred to more than 1,000 feet and are thus sufficiently long (Chow, 1959) that there is full pipe flow in the conduit and free discharge from the outlet. If the elevation of the downstream backwater is above the critical depth elevation, the depth associated with the backwater may control the flow in the culvert. One of these conditions typically occurs, such that culverts flow full for their entire length (Figure 9.31b).

When a culvert is on a steep slope and the inlet is not submerged, the flow is controlled by critical depth at the inlet (Figure 9.32a), and open-channel flow at supercritical velocity will occur throughout the culvert. After the inlet has been submerged (H exceeds about $1.2D$), it is still possible to have open-channel flow at supercritical velocities in the culvert if the control point remains at the inlet (Figure 9.32b). In this case, discharge is governed by orifice flow at the inlet, leading to formation of a flow contraction at the top of the culvert entrance and aeration over the remaining culvert length.

As the head at a submerged inlet increases, friction or local disturbances may reduce the flow velocity, causing the culvert to flow full near the outlet. This may seal the downstream end of the pipe, even though an orifice flow contraction tends to occur at the inlet. The associated high-velocity flow will tend to carry away the air trapped at the top of the culvert, thus reducing the internal pressure to less than atmospheric pressure. This can lead to damage to the culvert from cavitation (Section 9.7.3.3). However, if the entrance is shaped to eliminate the inlet flow contraction, the culvert will start to flow full near the inlet, after which the full flow zone will extend rapidly toward the outlet. The effect of the full flow condition will be a draft tube action (similar to siphonic action) that will

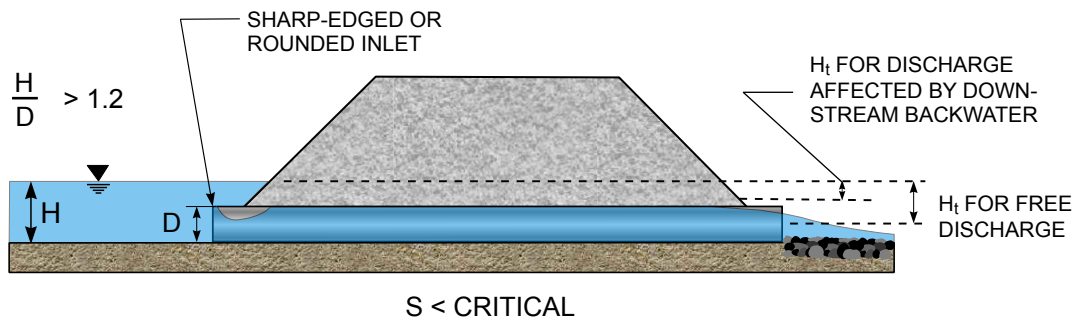
PART FULL FLOW-INLET NOT SUBMERGED

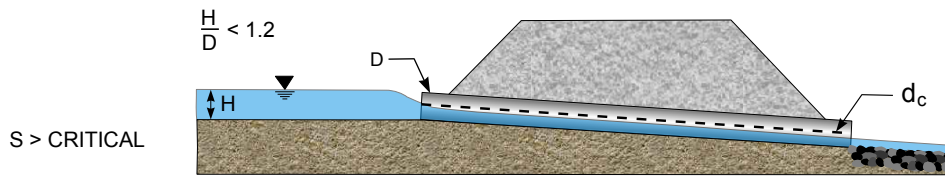

9.32a STEEP SLOPE - SUPERCRITICAL FLOW: CONTROL AT CRITICAL DEPTH AT INLET

PART FULL FLOW-INLET SUBMERGED

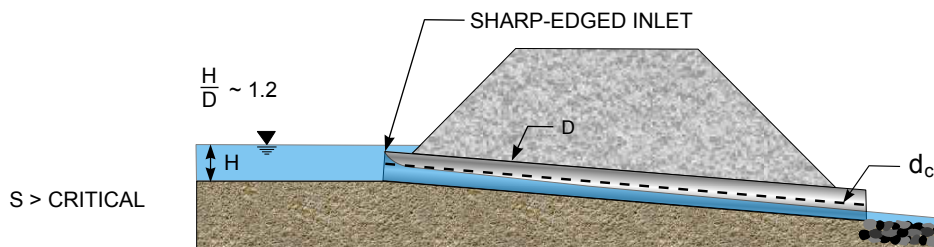

9.32b STEEP SLOPE - SUPERCRITICAL FLOW: ORIFICE FLOW CONTROL AT INLET

FULL FLOW-INLET SUBMERGED

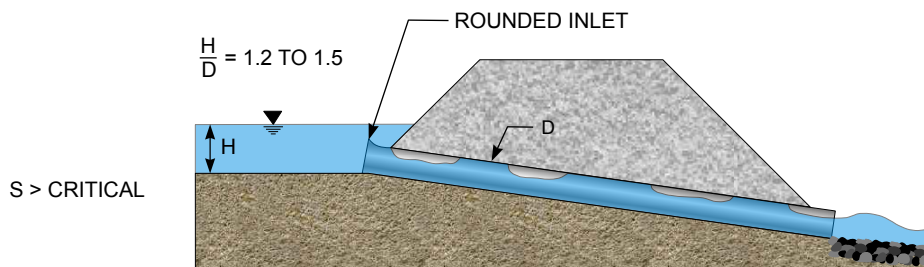

9.32c STEEP SLOPE - SUPERCRITICAL PULSATING SLUG FLOW: CONTROL SWITCHING BETWEEN INLET AND SECTION WITHIN THE CONDUIT

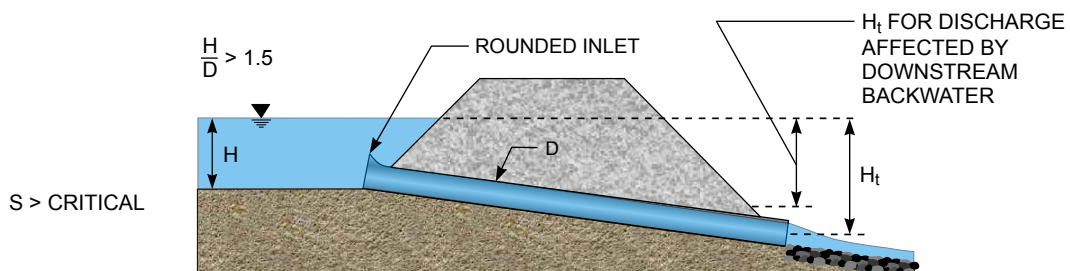

9.32d STEEP SLOPE CONTROL AT OUTLET EFFECTIVE HEAD = $H_t - \Sigma$ LOSSES

FIGURE 9.32 TYPICAL FLOW CONDITIONS – CULVERT CONDUITS ON STEEP SLOPES

increase the discharge. The increased discharge will cause a deep drawdown just upstream from the inlet, and a vortex will form, allowing air to enter the culvert, breaking the draft tube action. This immediately reduces the discharge and causes a return to orifice control at the inlet. The full flow action will begin again and the cycle will be repeated. This alternating action will cause a pulsating slug flow phenomenon (Figure 9.32c). When the storage elevation and culvert dimensions are such that the H/D ratio exceeds about 1.5, the inlet drawdown will be insufficient to allow air to enter the culvert and steady full flow will prevail (Figure 9.32d).

The flow velocity during the full-flow conditions illustrated by Figures 9.31b and 9.32d can be determined from the Bernoulli equation:

$$\frac{V^2}{2g} = H_t - \sum \text{losses} \quad (9-19)$$

where:

- V = flow velocity (ft/sec)
- g = acceleration of gravity (ft/sec²)
- H_t = head (elevation difference) between the impoundment surface and the point of discharge (ft)

The term “ \sum losses” encompasses all flow-reducing conditions associated with the inlet, culvert geometry and culvert friction. These losses can be related to the velocity by:

$$\sum \text{losses} = \frac{V^2}{2g} (f \frac{L}{D} + \sum K_L) \quad (9-20)$$

where:

- f = friction factor for the culvert material and flow condition in the culvert
- L = length of the culvert (ft)
- D = diameter of the culvert (ft)
- $\sum K_L$ = sum of head losses associated with the inlet, valves, constrictions and directional changes (ft)

For most flow conditions and circular culvert materials, the friction factor (f) can be determined from the following equation:

$$f = 185 n^2 / d^{1/3} \quad (9-21)$$

where:

- n = Manning's roughness coefficient for culvert
- d = pipe diameter (ft)

By substituting terms from Equation 9-20 into Equation 9-19, the relationship between H_t and V becomes:

$$H_t = \frac{V^2}{2g} (f \frac{L}{D} + \sum K_L + 1) \quad (9-22)$$

Typical head loss coefficients K_L are tabulated in [Table 9.14](#). After all of the loss parameters have been determined, Equation 9-22 can easily be solved.

However, Equation 9-22 is only appropriate when dealing with water at normal temperatures. The friction factor approach is superior when working with smooth pipes and/or large values of Reynolds number. For materials and pipe sizes commonly used, the above equation will give acceptable results. When unusual surfaces or very large pipe sizes are involved or when very long conduits with large energy losses are used, an experienced hydraulic engineer should be consulted.

The geometry of an inlet is important to achieving discharge efficiency. Until the headwater surface is well above the culvert inlet, a square-edged inlet produces an inlet flow contraction without greatly reducing the discharge capacity. Flow contractions can also be formed (but at reduced discharge capacity) by a projecting inlet, a mitered inlet, an inlet orifice ring, or a top curtain wall closure. These inlet configurations are shown in [Figure 9.33](#).

TABLE 9.14 HEAD LOSS COEFFICIENTS FOR CONDUITS

K_L for Inlets (USBR, 1987a)				
Inlet Type		K_L		
Fully rounded entrances ($r/D \geq 0.15$) flush with vertical walls		0.10		
Square edge entrances flush with vertical walls		0.50		
Socket-ended concrete pipe flush with vertical walls		0.15		
Projecting concrete pipe with socket ends		0.20		
Projecting smooth-wall or corrugated pipe		0.85		
Gate in thin wall – unsuppressed contraction		1.50		
Gate in thin wall – corners rounded		0.50		
K_L for Directional Changes (Linsley and Franzini, 1972)				
Radius of Bend/Pipe Diameter		Angle of Bend		
		90°	45°	22.5°
1	K_L	0.50	0.37	0.25
2	K_L	0.30	0.22	0.15
4	K_L	0.25	0.19	0.12
6	K_L	0.15	0.11	0.08
8	K_L	0.15	0.11	0.08
K_L for Valves and Fittings (Linsley and Franzini, 1972)				
Type of Valve or Fitting		K_L		
Butterfly valve (wide open)		0.2		
Gate valve (wide open)		0.2		
Gate valve (half open)		5.6		
Return bend		2.2		
Standard tee		1.8		
Standard 90° elbow		0.9		

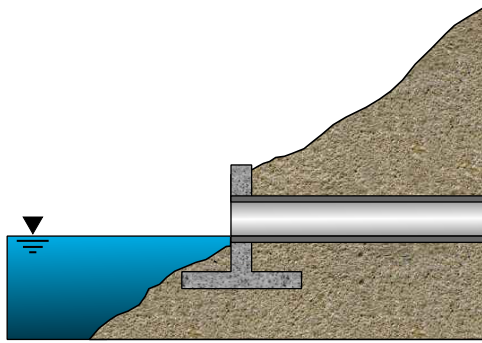

9.33a SQUARE-EDGED INLET

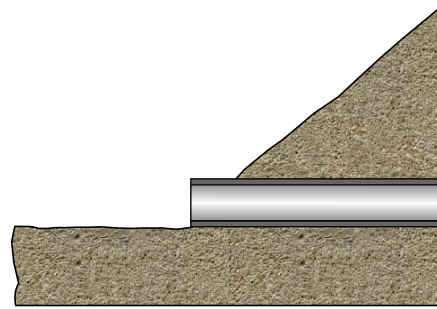

9.33b PROJECTING INLET

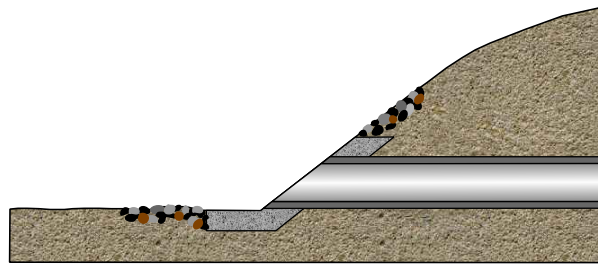

9.33c MITERED INLET

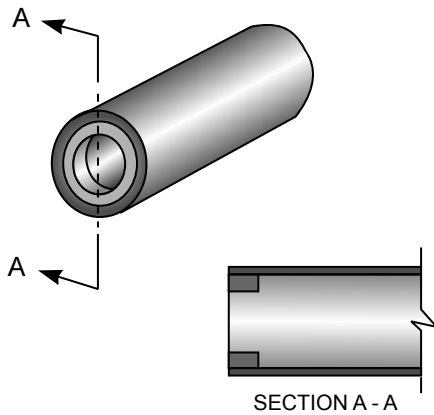

9.33d INLET ORIFICE RING

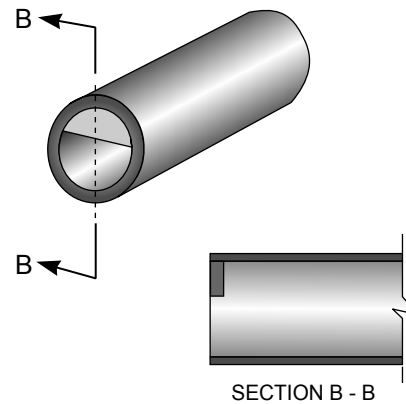

9.33e TOP CURTAIN WALL INLET

FIGURE 9.33 CULVERT INLET CONFIGURATIONS

If it is desired that a culvert flow full at increased headwater elevations, the control point during maximum flow will be at the outlet and the geometry of the inlet will be less significant. For this case, the inlet should be shaped so as to minimize the inlet flow contraction, thereby increasing the tendency for full flow for all conditions except when the inlet is not submerged. Streamlining the shape of the inlet will streamline the flow and reduce inlet head losses. The tendency to develop cavitation pressures will also be reduced. Rounded entrances or a gradually tapering transition in size to the basic culvert dimension will generally provide the desired streamlining.

It is obvious from the previous discussions and related tables and figures that culvert inlets may vary with respect to approach conditions, entrance arrangements, and cross-sectional shapes. For example: (1) the approach to the inlet may or may not be a well defined channel with or without constructed wing walls, (2) the culvert may be flush with or protrude past the upstream embankment surface or constructed headwall, (3) the face may be square, beveled or rounded, and (4) the cross section may be round, square, rectangular or arched. All such variations have a marked influence on culvert performance as they affect weir or orifice discharge, inlet flow contractions and head losses during flow entrance to the culvert.

For coal refuse disposal facilities, circular culverts with vertical square-edged headwalls and flared wingwalls are sometimes encountered. The hydraulic design for these installations is discussed in detail by the USBR (1987a). Also, procedures and charts for design of these types of culverts are presented in FHWA (2005b).

The purpose of hydraulic analysis of a closed-conduit system is similar to that for an open-channel spillway, which is to determine the relationship between the elevation of the impounded storage (headwater) and the rate of outflow or discharge from the system. The head-discharge relationship for culvert-type conduit systems may be controlled by weir, orifice and pressure flow conditions depending on the upstream head, as illustrated in [Figures 9.31](#) and [9.32](#).

Drop Inlet Conditions

Closed-conduit flow in drop-inlet decant systems is similar to that for culvert systems, as discussed above. The relationship between the elevation of the impounded storage and the rate of discharge during these types of flow is indicated by the curves shown in [Figure 9.34](#). For the drop-inlet systems illustrated in [Figure 9.34](#), curve A results from crest-controlled (also referred to as weir-controlled) flow, as affected by the inlet geometry and water level conditions. The inlet geometry can range from a sharp-edged, vertically placed circular pipe to an elaborately formed concrete ogee called a morning glory spillway.

Curve B results from orifice-controlled flow. The flow control point for curve A is at the crest, as illustrated in [Figure 9.34a](#). The flow control point for curve B is at the entrance to the transport section of the conduit, as illustrated in [Figure 9.34b](#). The curve B flow condition occurs when the open-channel capacity of the transport section and the discharge capacity of the outlet are both greater than the capacity of the inlet orifice. This results in a backup of water in the drop tube and drowning of the inlet weir.

The curve C flow condition is associated with full flow, generally controlled by the transport section. Analysis for the curve C condition is the same as for a culvert system under full flow (Equation 9-22) except that an additional head loss term related to the drop inlet should be included. The loss coefficient K_L for the transition from the drop inlet to the transport section can range from 0.2 for an unobstructed, specially-formed structure to 2.0 for a debris-clogged, square-edged turn. A value of 1.0 is normally satisfactory for design.

To maximize the discharge capacity of decant systems under low heads, conical-shaped inlets that extend the crest control flow (curve A) have been employed. Other inlet shapes that incorporate an orifice ring have been used to maintain orifice flow (curve B) and to prevent the transport pipe section from flowing full or under pressure.

As a guide for assisting the designer in the evaluation of important secondary characteristics affecting closed-conduit flow, a list of Manual sections and supplemental references for secondary hydraulic design issues is provided in [Table 9.15](#).

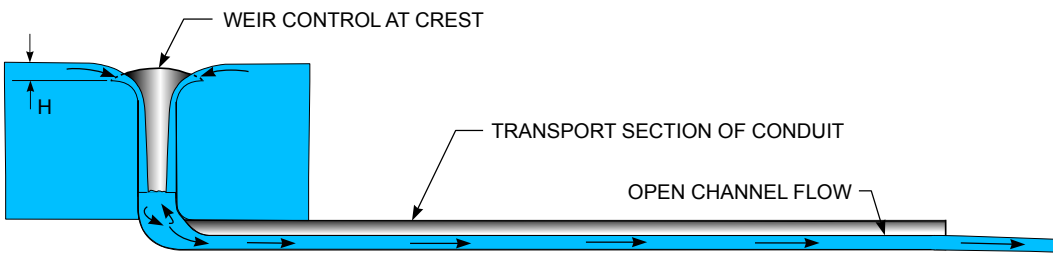

9.34a CURVE A - CREST CONTROL

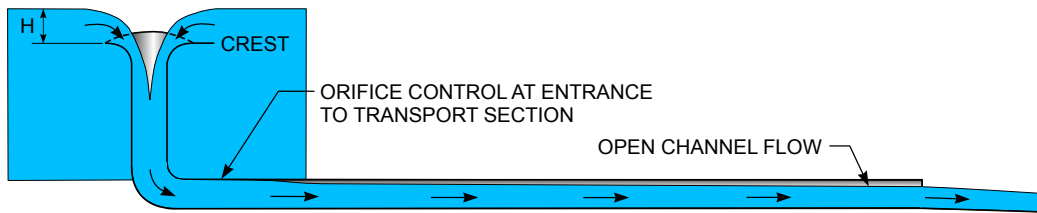

9.34b CURVE B - ORIFICE CONTROL

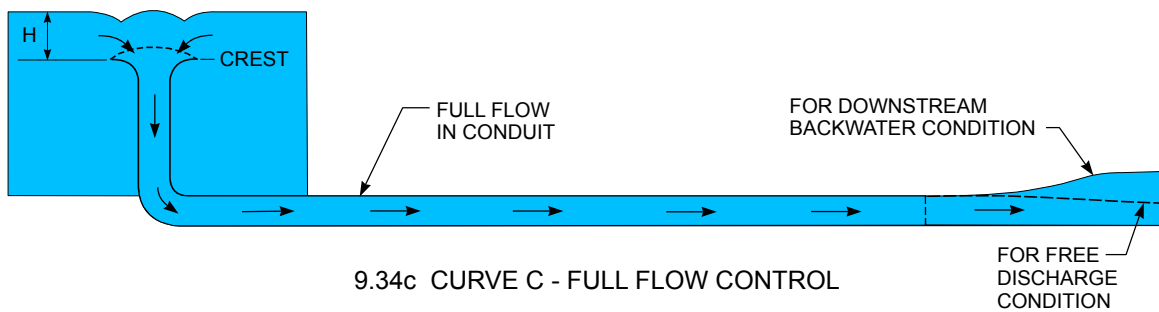

9.34c CURVE C - FULL FLOW CONTROL

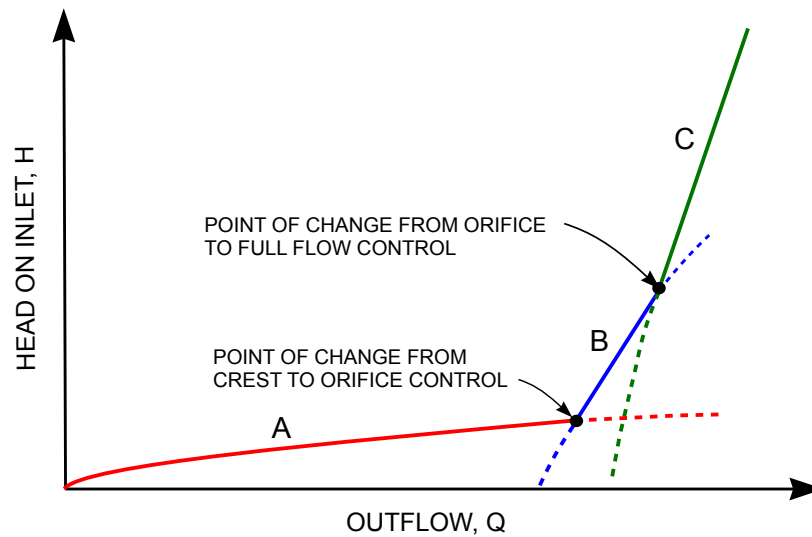

FIGURE 9.34 FLOW AND DISCHARGE CHARACTERISTICS OF DECANT-INLET, CLOSED-CONDUIT SYSTEM

TABLE 9.15 REFERENCES FOR SECONDARY HYDRAULIC DESIGN ISSUES

Item	Manual Section	Supplemental References
External Embankment Pressure	6.6.6.2	FEMA (2005a)
Internal Water Pressure	9.7.2.2	Brater et al. (1996)
Thrust Forces	9.7.3.5	Brater et al. (1996)
Trash Racks	9.7.4.1	USBR (1987a)
Vortex Control	9.7.4.1	USBR (1987a)
Flow at Bends	9.7.3.4	Brater et al. (1996), USACE (1980)
Cavitation	9.7.3.3	USACE (1980), USBR (1990)
Materials Selection	6.6.6.1	FEMA (2005a)

9.7.2.3 Outlets

There are two basic requirements that typically dictate the size, configuration and location of the outlet section of the hydraulic system:

1. If the outlet is intended to control the relationship between headwater storage and outflow for the entire hydraulic system, the outlet size and configuration must be designed specifically for this purpose.
2. The configuration and location of the outlet must be such that discharged water will not create a hazardous condition (e.g., erosion of the channel or embankment toe) and the energy of the outflow will be dissipated. The potential for localized damage must be controlled to a level acceptable to the owner and to regulatory agencies.

Whether the first requirement applies depends upon the design choices for the inlet and transport sections of the system, as previously discussed. If applicable, the outlet size and configuration must be designed to control the required discharge, generally by weir or orifice control. Evaluation of this discharge was discussed in [Section 9.7.2.1](#) and is not discussed further herein.

The second requirement has more general significance and necessarily requires considerable planning at the earliest stages of design so that the outlet of the hydraulic system will not be incompatible with any other portion of the coal refuse disposal facility. Criteria to be considered in determining the degree of effort required for construction of an outlet system normally include:

- Under no circumstance should the outlet location or configuration allow flow to discharge beyond the outlet in a manner that could contribute to embankment failure, endangering lives or major downstream property.
- Situations where significant localized damage could occur during moderate storms should be avoided. Exceptions are when the cost of constructing a damage-safe outlet far exceeds the cost of occasional maintenance. Often the 100-year storm ([Section 9.5](#)) is considered as the basis for design when it is unlikely that lives or major downstream property could be endangered.
- For very large storms, such as those approaching the PMF ([Section 9.5](#)), it is generally not required that the outlet totally prevent downstream damage due to discharge, if the first criterion above is satisfied. Under such severe storms, significant downstream damage (such as erosion and roadway overtopping) can be expected to occur even if the hydraulic system of the disposal facility satisfies all requirements of good design.

DISCHARGE WITHOUT ENERGY DISSIPATING STRUCTURES

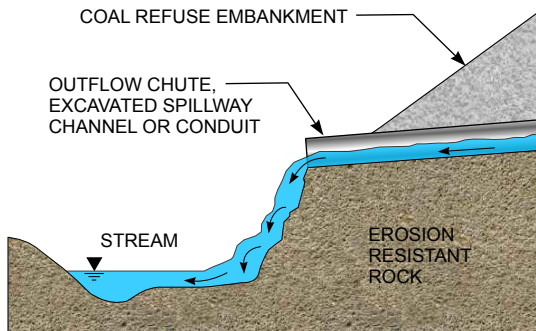

9.35a FREE OUTFALL

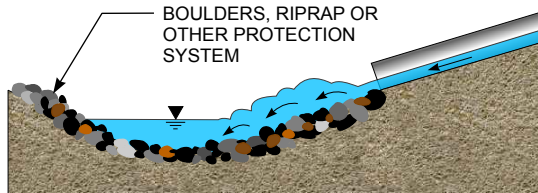

9.35b RIPRAP PROTECTION

DISCHARGE WITH ENERGY DISSIPATING STRUCTURES

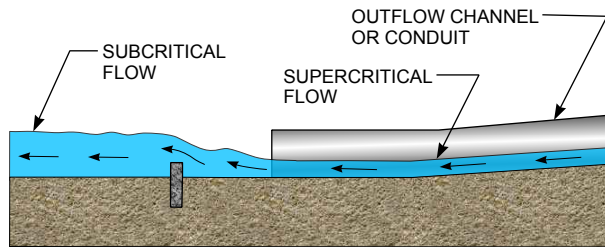

9.35c HYDRAULIC JUMP STILLING BASIN

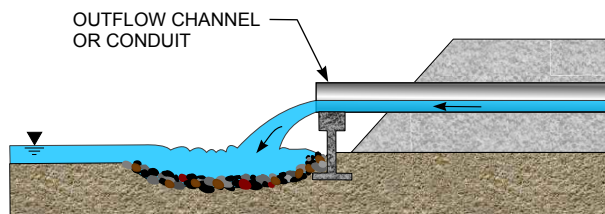

9.35d PLUNGE POOL STILLING BASIN

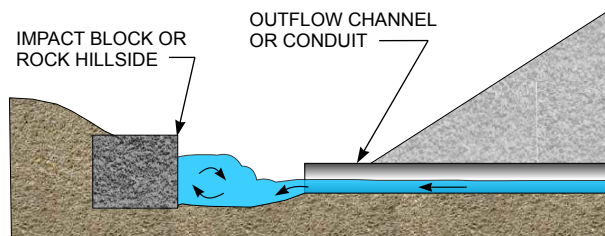

9.35e IMPACT BLOCK STILLING MECHANISM

FIGURE 9.35 EXAMPLES OF CHANNEL AND CONDUIT OUTLETS

Several types of outlet conditions are illustrated in Figure 9.35. If the discharge point can be located an adequate distance away from the overall facility, the most reliable and least expensive outlets are those that allow the flow to discharge over erosion resistant rock or large riprap. This type of outlet condition is most often used when the channel or spillway will function only infrequently because of the limited recurrence of very large storms.

The energy dissipating structures shown in Figure 9.35 are commonly used for water-impounding earth dams, but are normally not necessary for coal refuse disposal facilities if sufficient access is available that periodic maintenance and repair can be performed. However, such outlets should be considered for moderate but regular discharges or when future access could be difficult. Also, if extending the transport section a significant distance beyond the downstream limits of the facility will be costly, coupling a short transport section with an energy-dissipating structure may be a more cost-effective solution.

State and local agencies may prefer specific methods or structures for energy dissipation at outlet structures, and applicable regulatory guidance should be reviewed as part of design. Hydraulic

design requirements for structures similar to those shown in [Figure 9.35](#) are discussed by FHWA (2006), USACE (1990b), USACE (1980), and USBR (1987a).

9.7.3 Special Design Considerations

The following discussion briefly emphasizes some important special considerations of hydraulic system design and illustrates situations where special conditions must be evaluated.

9.7.3.1 Channel Freeboard

Freeboard is needed in open channels to account for minor channel irregularities, air entrainment and wave action. The required freeboard is a function of the design flow velocity and flow depth and typically varies from less than 5 percent to greater than 30 percent of the depth of flow (Chow, 1959). Low freeboards may be appropriate for smooth, uniform channels with flow velocities less than 8 feet per second. The following is an empirical relationship that provides the desirable spillway channel freeboard based upon surface roughness, wave action, air bulking, splash, and spray under supercritical conditions (USBR, 1987a):

$$\text{Freeboard (ft)} = C_f + 0.025 V D^{1/3} \quad (9-23)$$

where:

- C_f = freeboard coefficient
- V = design flow velocity (ft/sec)
- D = flow depth (ft)

The USBR (1987a) has indicated that a value of C_f equal to 2 is desirable for spillway channels for dams. While Equation 9-23 has been applied to spillways with the cited flow conditions, this formula has been used by some state agencies for the design of uniform channels ranging from perimeter and diversion ditches to small spillway channels by adopting values for C_f ranging from 0 (with not less than 0.3 feet of freeboard) to 1. MSHA (2007) has indicated that a value of C_f equal to 1 is prudent for design of perimeter ditches. Channel bends, convergence, and other geometric changes may require greater freeboard to address variations in the flow profile. Additional discussion is presented in [Section 9.7.3.4](#).

9.7.3.2 Erosion Protection

Two methods are typically employed in the design of erosion protection linings for channels: (1) the permissible velocity method or (2) the tractive (shear stress) force method. Under the permissible velocity approach, the channel is assumed to be stable if the mean velocity is lower than the maximum permissible velocity for the channel materials. The tractive force approach focuses on stresses at the channel boundary. The factors that normally cause erosion are velocity of flow (e.g., in steep channels and at intakes) and water impact at points where direction changes occur (e.g., at sharp bends in channels, at the intersection of channels, and where free-falling water discharges from a channel or conduit). If unchecked, erosion can result in degradation of water quality and frequent maintenance. Excessive or uncontrolled erosion on or near an impounding embankment can result in catastrophic failure during large storms.

The shear resistance of the soil/rock in an unlined channel or the shear resistance provided by the channel lining will determine the stability of the channel relative to erosion. The shear force generated by water flowing through a channel section is given by:

$$\tau = \gamma R S \quad (9-24)$$

where:

- τ = shear stress along the wetted perimeter of flow (lb/ft²)
- γ = unit weight of water (lb/ft³)
- R = hydraulic radius = A/WP (ft)
- S = energy grade line slope (equal to the channel slope for uniform flow) (ft/ft)

The maximum shear stress on the channel bottom and sides in a straight channel depends on the channel shape. For trapezoidal channels with a ratio of bottom width to depth greater than 4, the maximum shear stress on the channel bottom frequently governs the lining selection and can be estimated using the relationship (FHWA, 2005a):

$$\tau_d = \gamma d S \quad (9-25)$$

where:

- τ_d = shear stress in channel at maximum depth (lb/ft²)
- d = maximum depth of flow in channel (ft)

For bottom width to depth ratios less than 4, the above equation conservatively overestimates the shear stress for straight uniform channels. If a more refined analysis is desired, Equation 9-24 should be applied.

The shear stress on the wetted perimeter (τ) is then compared with the permissible shear stress (τ_p) for the channel bottom or lining. If the permissible shear stress is greater than or equal to the computed shear stress, including a safety factor (SF), the channel and lining are considered stable. If this condition is not met, a different channel configuration or lining with a higher permissible shear stress is selected. The concept is expressed as:

$$\tau_p \geq SF \tau \quad (9-26)$$

The safety factor provides for a measure of uncertainty and conservatism for the designer. A safety factor of 1.5 is generally recommended for the following conditions:

- Critical or supercritical flows
- Climatic regions where vegetation may be uneven or slow to establish
- There is significant uncertainty regarding the design discharge
- The consequences of failure are high

Permissible velocity and tractive shear force values for channel linings are presented in [Table 9.16](#). Determination of allowable tractive shear forces for commercially available erosion control products should be obtained from the manufacturers. Determination of tractive shear forces for grass- and riprap-lined channel sections is a function of the vegetation retardance class and the median riprap size for grass- and riprap-lined channels, respectively. More detailed explanations of the design procedures for grass- and riprap-lined channels are presented below. It should be noted that the use of grass and riprap erosion protection will generally be limited by the channel slope. For steep embankments with slopes greater than 10 percent, grass or riprap channel lining has limited application. Grouted riprap and concrete should be considered when tractive forces exceed the allowable limits for grass or riprap channel linings. Also, commercially manufactured products have been developed

TABLE 9.16 PERMISSIBLE VELOCITY AND TRACTIVE FORCE FOR CHANNEL LININGS

Channel Lining	Permissible Velocity ⁽¹⁾ (ft/sec)	Permissible Tractive Force ⁽²⁾ (lb/ft ²)
Temporary Lining		
Jute netting		0.45
Straw with net		1.45
Coir-double net		2.25
Coconut fiber-double net		2.25
Curled wood mat		1.55
Curled wood-double net		1.75
Curled wood-high velocity		2.00
Synthetic net		2.00
Vegetative Lining		
Class A		3.70
Class B		2.10
Class C		1.00
Class D		0.60
Class E		0.35
Kentucky Bluegrass, Tall Fescue ⁽³⁾	5-7	
Grass Mixture, Red Canarygrass ⁽³⁾	4-5	
Lespedeza Sericea, Weeping Lovegrass Redtop, Red Fescue, Annuals ⁽³⁾	2.5-3.5	
Riprap⁽⁴⁾		
R-1	2.5	0.25
R-2	4.5	0.50
R-3	6.5	1.00
R-4	9	2.00
R-5	11.5	3.00
R-6	13	4.00
R-7	14.5	5.00
R-8	17	8.00
Gabions	22	8.35
Reno Mattress		
6-10 inches thick	12	8.35
10-12 inches thick	15	8.35
12-18 inches thick	18	8.35

Note: 1. USACE (1994), PADEP (2000); permissible velocity should only be applied in cases of straight, uniform steady flow (e.g., bank protection)

2. FHWA (2005a), PADEP (2000)

3. Permissible velocity range for easily eroded to erosion resistant soils (clayey fine-grained soils and coarse-grained soils) at slopes less than 5 percent. Use velocity exceeding 5 ft/sec only where good cover and proper maintenance can be provided.

4. Based on rock with unit weight of 165 lb/ft³.

to provide greater tractive shear resistance for steeper slopes, but product limitations and the importance of quality construction practices must be clearly understood, if these products are used.

9.7.3.2.1 Grass-Lined Channels

Design of stable grass-lined channels is related to the type of vegetation selected, as reflected by the vegetation retardance class and the tractive stress associated with peak flow. The FHWA (2005a) presents design procedures and data for the design of vegetative linings. Grass linings control erosion by dissipating shear force within the grass stems before it reaches the soil surface, and the root and stem stabilize the soil against turbulent water forces. As indicated in [Table 9.17](#), vegetation retardance for grasses is divided into five classes – A through E. In general, taller and denser grass species have a higher resistance to flow (Class A), while short flexible grass has a low resistance to flow (Class E). The design procedure presented in FHWA (2005a) includes initially estimating the flow depth and effective shear stress on the grass lining based on the grass retardance class, roughness, stiffness, and cover conditions. Manning's n is determined from the effective shear stress, and the discharge is computed and compared to the original estimate. Through a series of iterations, a solution is obtained that balances the flow depth, shear stress, and discharge. The permissible shear stress for the soil type is then estimated from soil properties such as grain size, plasticity, and void ratio for comparison to the effective shear stress.

Haan and Barfield (1978) present a simplified procedure in which permissible velocities for vegetated channels are used with the relationship between channel conveyance and Manning's n for the retardance classes shown in [Figure 9.36](#). [Table 9.17](#) presents the vegetative cover and condition for various retardance classes. The design procedure is to: (1) select the vegetation and an initial estimate of n , (2) determine retardance class and permissible velocity based on [Table 9.17](#) and an initial estimate of VR (velocity V times hydraulic radius R) from the curves in [Figure 9.26](#), (3) obtain the permissible velocity for the vegetation based on [Table 9.16](#) (or state regulatory guidance manual values) and (4) compute the hydraulic radius R from Equation 9-18 using the permissible velocity. The product of the permissible velocity and R from Step 4 is compared with the initial estimate of VR to determine a new value of VR until convergence.

Commercially available erosion control products can be used to reinforce natural vegetation, including non-degradable synthetic fibers, filaments, netting and/or wire mesh. These materials can be integrated into the vegetation and soil lining or applied over the surface, affecting performance and altering the design procedure. The FHWA (2005a) presents design methods for incorporating such products into the design of channel linings, and manufacturers have developed software for analysis of unreinforced and reinforced vegetated channel sections (e.g., North American Green's Erosion Control Materials Design software). When such software is used, knowledge of the grass retardance class, vegetation type, soil type and duration of peak flow are essential requirements in the determination of the tractive shear resistance of the channel linings.

9.7.3.2.2 Riprap-Lined Channels

Riprap linings consist of a layer of rock or stone with a characteristic size, generally designated by D_{50} , the median grain size of the lining material. As with grass linings, the flow conditions and channel shear stress are a function of the Manning's n , and an iterative procedure is required for evaluating lining stability. Values for permissible shear stress for riprap linings are based on laboratory and field research. More turbulent flow conditions are more likely to cause lining failure, and a higher safety factor is recommended for such conditions. Typically, for situations where riprap is needed, a safety factor of 1.5 should be used, although a lower value may be justifiable with mild slopes and low velocities. The FHWA (2005a) presents a design procedure for riprap-lined channels.

Barfield et al. (1981) present a simplified approach for riprap lining design based on USACE procedures and the critical tractive shear stress. The force on median-size riprap at the threshold of

TABLE 9.17 VEGETAL RETARDANCE CLASSES

Retardance Class	Cover	Condition
A	Reed canarygrass	Excellent stand, tall (average 36 inches)
	Yellow bluestem ischaemum	Excellent stand, tall (average 36 inches)
B	Smooth bromegrass	Good stand, mowed (average 12 to 15 inches)
	Bermudagrass	Good stand, tall (average 12 inches)
	Native grass mixture (little bluestem, blue grama, and other long and short mid-west grasses)	Good stand, unmowed
	Tall fescue	Good stand, unmowed (average 18 inches)
	Sericea lespedeza	Good stand, not woody, tall (average 19 inches)
	Grass-legume mixture – Timothy, smooth bromegrass, or orchardgrass	Good stand, uncut (average 20 inches)
	Reed canarygrass	Good stand, mowed (average 12 to 15 inches)
	Tall fescue, with bird's foot trefoil or iodino	Good stand, uncut (average 18 inches)
	Blue grama	Good stand, uncut (average 13 inches)
	C	Bahia
Bermudagrass		Good stand, mowed (average 6 inches)
Redtop		Good stand, headed (15 to 20 inches)
Grass-legume mixture – summer (orchardgrass, redtop, Italian ryegrass, and common lespedeza)		Good stand, uncut (6 to 8 inches)
Centipedegrass		Very dense cover (average 6 inches)
Kentucky bluegrass		Good stand, headed (6 to 12 inches)
D	Bermudagrass	Good stand, cut to 2.5-inch height
	Red fescue	Good stand, headed (12 to 18 inches)
	Buffalograss	Good stand, uncut (3 to 6 inches)
	Grass-legume mixture – fall, spring (orchardgrass, red-top, Italian ryegrass, and common lespedeza)	Good stand, uncut (4 to 5 inches)
	Sericea lespedeza	After cutting to 2-inch height, very good stand before cutting
E	Bermudagrass	Good stand, cut to 1.5-inch height
	Bermudagrass	Burned stubble

(HAAN AND BARFIELD, 1978)

motion is considered to be the critical tractive resisting force per unit area (τ_c) for riprap-lined channel sections. Since riprap is a layer of discrete, individual rocks, the movement of an individual rock can initiate further erosion, weakening the overall long-term erosion resistance of the riprap layer. For most situations at coal refuse disposal facilities, the general practice is to consider application of a safety factor for the channel base (SF_{base}) of 1.5 for the design of riprap channel sections. The critical tractive resisting force at the channel base can be estimated from the following equation:

$$SF_{base} = (\cos \theta \tan \phi) / (\sin \theta + \eta b \tan \phi) \quad (9-27)$$

where:

$$\eta b = \tau / \tau_c$$

$$\tau = \text{shear force per unit area on channel bed} = \gamma R S \text{ (lb/ft}^2\text{)}$$

$$\tau_c = \text{critical tractive resisting force per unit area} = 0.047 \gamma (SG - 1) D_{50} \text{ (lb/ft}^2\text{)}$$

$$\gamma = \text{unit weight of water (lb/ft}^3\text{)}$$

$$R = \text{hydraulic radius of channel (ft)}$$

$$SG = \text{specific gravity} = 2.65 \text{ for durable limestone and sandstone}$$

$$D_{50} = \text{median riprap diameter (ft) (Table 9.18)}$$

$$S = \text{energy grade line slope (equal to the channel slope for uniform flow) (ft/ft)}$$

$$\theta = \text{channel bed slope (deg)}$$

$$\phi = \text{angle of repose of riprap (deg)}$$

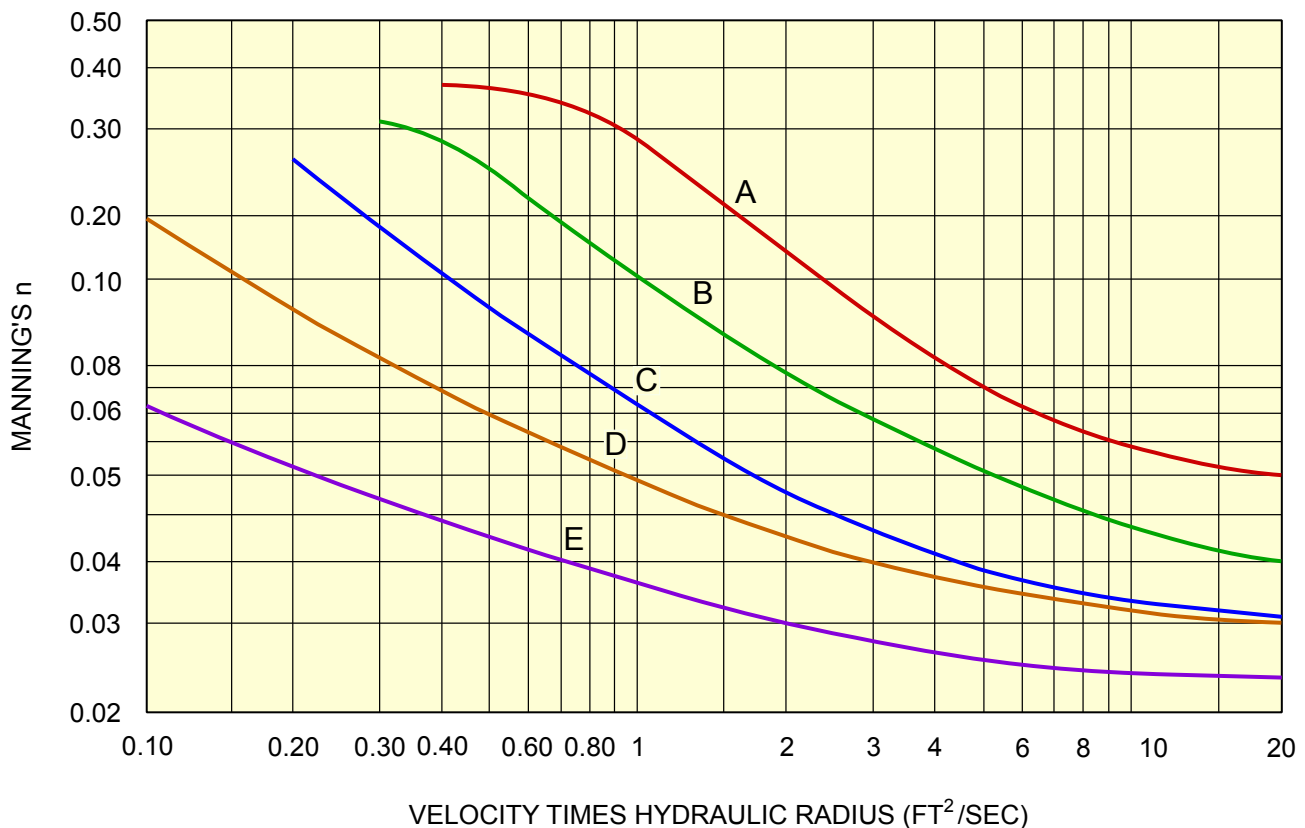

(HAAN AND BARFIELD, 1978)

FIGURE 9.36 MANNING'S n VERSUS VR FOR VARIOUS RETARDANCE CLASSES

Table 9.18 presents guidance for estimating D_{50} for various classes of riprap based on data from the National Stone, Sand and Gravel Association (NSSGA, 1989). The FHWA (1989) presents guidance for estimating the angle of repose of riprap based on size and angularity; common values are typically in the range of 35 to 40 degrees. The tractive force on the channel bank is less than that applied to the channel bottom and can be estimated separately (Barfield, et al., 1981), although due to constructability issues, the riprap used for the channel base is also generally used for the channel banks. The FHWA (2005a) also provides a method for checking bank riprap stability.

TABLE 9.18 RIPRAP SIZE DESIGNATION

Graded Riprap Stone				
NSSGA No. ⁽¹⁾	Sieve or Square-Opening Size (in)			Recommended Filter Stone
	Maximum	D_{50}	Minimum ⁽²⁾	NSSGA Size No. ⁽¹⁾
R-1	1½	¾	No. 8	FS-1
R-2	3	1½	1	FS-1
R-3	6	3	2	FS-2
R-4	12	6	3	FS-2
R-5	18	9	5	FS-2
R-6	24	12	7	FS-3
R-7	30	15	12	FS-3
R-8	48	24	15	FS-3

Filter Stone				
NSSGA No. ⁽¹⁾	Sieve or Square-Opening Size (in)			Recommended Placement Thickness
	Maximum	D_{50}	Minimum ⁽²⁾	(in)
FS-1	¾	No. 30	No. 100	3
FS-2	2	No. 4	No. 100	4 to 6
FS-3	6½	2½	No. 16	8 to 10

Note: 1. National Stone, Sand & Gravel Association (formerly National Stone Association) designation. The table is based on a stone dry density of 165 lb/ft³.

2. Pieces smaller than the minimum size shown should not exceed 15 percent of the tonnage shipped.

(ADAPTED FROM NSSGA, 1989)

At channel bends, a correction factor K_3 is normally applied for estimating the shear force:

$$\tau = K_3 \gamma R S \quad (9-28)$$

where:

$$K_3 = 4V^2/R_d \text{ (dimensionless)}$$

$$V = \text{straight channel velocity (ft/sec)}$$

$$R_d = \text{channel radius of curvature measured at the outside channel bank (ft)}$$

The FHWA (2005a) presents details and discussion of design procedures at bends, including the length over which increased shear stresses are experienced and the superelevation of the water surface at and downstream of bends.

Geotextiles have been used increasingly as the filter medium between the riprap and underlying material. However, riprap placed on a geotextile has a tendency to creep over time. Gravitational and water forces have a tendency to re-orient riprap toward the base of the channel resulting in exposed geotextile at the top of the channel slope. The use of an aggregate filter layer between the subbase soil and the

riprap is preferred to geotextile due to the increased frictional resistance between the aggregate filter material and the riprap. If geotextile is used, extra riprap should be placed on the channel slopes.

The recommended thickness and gradation of the filter stone in relation to the riprap size is presented in [Table 9.18](#). The recommended riprap layer thickness is greater than or equal to 1.5 times the D_{50} stone size or greater than or equal to the D_{100} size, whichever is greater (FHWA, 1989).

The publication *Practical Riprap Design* (Maynard, 1978) based on model testing provides riprap size as a function of channel flow depth and Froude number (function of velocity and depth). Additionally, the USACE (1994) provides a generalized procedure for determining riprap size and distribution, including guidance for steep slope conditions (up to 20 percent). The model studies and guidance have proved beneficial for determining riprap requirements in steep slope conditions where the tractive force determined from Equation 9-27 may result in large riprap size relative to flow depth such that uniform flow conditions may no longer be valid. In such steep slope conditions, grouted riprap is often employed to reduce the riprap size. Software is available for riprap design that utilizes the USACE and other procedures.

9.7.3.2.3 Grouted-Riprap Channels

Grouted-riprap channel lining consists of riprap with a cement grout filling the voids to create a monolithic erosion protection mat. The use of grouted riprap can reduce the size and quantity of rock required in a channel lining by creating a greater material mass to resist hydraulic forces. Because grouted riprap linings are rigid, they are susceptible to cracking and damage due to subbase movement or freeze-thaw action. The tractive force resistance of cracked, unconfined grout sections is dependent on intimate surface contact between adjacent sections, section mass, and flow characteristics. In situations of severe cracking with displacement, the primary resistance to tractive forces is the grout and rock fragment pieces, which may be only slightly greater in size and mass than the riprap alone. Thus, to limit the potential for displacement, subbase design is very important.

Design procedures for grouted-rock linings installed on channel banks are provided in FHWA (1989) and address aspects such as rock size and lining thickness, rock grading, filter design, and pressure relief. Rock size and lining thickness are a function of the flow velocity; the median rock size should not exceed two-thirds of the lining thickness, and the largest rock size should not exceed the lining thickness. [Table 9.19](#) and [Figure 9.37](#) can be used to estimate the riprap thickness based on velocity, riprap size and the recommended depth of the grout penetration as follows:

- Based on the average flow velocity, [Figure 9.37](#) can be used to estimate the riprap thickness. For the case where the ratio of bottom width to depth is greater than 2, the flow velocity should be increased by 25 percent when determining the riprap thickness.
- The gradation should be selected based on available riprap class (e.g., cobbles), considering that the median rock size should not exceed two-thirds of the lining thickness and the largest rock size should not exceed the lining thickness. [Table 9.19](#) presents AASHTO class designations based on weight, which is approximately equivalent to the effective diameter shown.
- Grout penetration recommendations for each class or size of riprap are also presented in [Table 9.19](#).

This procedure is applicable to trapezoidal channels where the ratio of bottom width to depth is less than 2. For wider channels, the velocity and shear stress on the channel bottom may be greater, and a corresponding adjustment in velocity or shear stress may be necessary. Typically, the design velocity will increase by 25 percent because the tractive shear for channel side slopes is approximately 75 percent of the maximum shear at the base of the channel.

TABLE 9.19 RECOMMENDED GRADING OF GROUTED ROCK RIPRAP LINING

Rock Sizes Equivalent Diameter (ft)	Classes (Percent Larger Than Given Rock Size)						
	2.75	2.25	1.75	1.25	1.0	0.5	
3.5	0-5						
2.75	50-100	0-5					
2.25	50-100		0-5				
1.75	95-100		50-100	0-5			
1.25	95-100			50-100	0-5		
1.0				95-100	95-100	50-100	0-5
0.5				95-100		95-100	
Minimum Penetration of Grout (ft)	2	1.5	1.3	0.8	0.67	0.5	

(FHWA, 1989)

Similar to riprap channel lining, the use of an aggregate filter layer between the natural ground surface and the riprap is recommended, but geotextiles can also be used in this application provided the riprap does not shift on channel slopes during construction or under subsequent flow conditions.

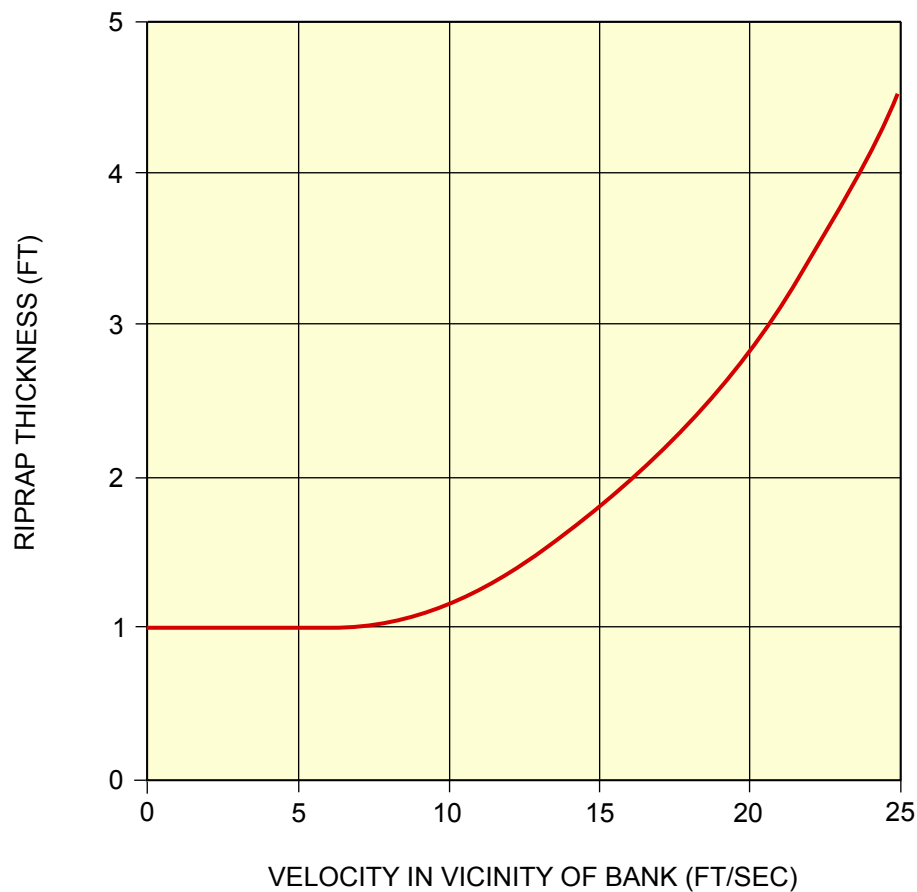

(FHWA, 1989)

FIGURE 9.37 GROUTED RIPRAP LINING THICKNESS AS A FUNCTION OF FLOW VELOCITY

Foundation preparation is a critical factor in the performance of a grouted riprap lining. Grouted riprap is not flexible and foundation conditions, the potential for development of hydrostatic pressure beneath the rigid mat, and end treatment conditions need to be evaluated as part of the design and construction process. Damage to any section of grouted riprap lining can result in complete failure of the system.

The foundation for grouted-riprap channel lining should be a contoured, firm stable surface. Small surface irregularities can be accommodated within the filter stone layer. The slopes should be graded at no steeper than 1.5H:1V.

Weep holes for hydrostatic pressure relief should be installed in a grouted riprap channel lining. The weep holes should extend below the grouted surface to the gravel zone between the grout and the filter stone. It is recommended that 3-inch-diameter weep holes, constructed from PVC pipe and with protective end screening, be installed at maximum 10-foot vertical spacing (FHWA, 1989).

The head, toe and terminal ends of grouted riprap linings require special treatment such as extension of the lining to rock or to a depth below potential scour to prevent undermining. Additional riprap can provide extra protection against undercutting at a bank toe. Figure 56 of *Hydraulic Engineering Circular 11* (FHWA, 1989) presents recommended construction details for these treatments. Guidance is also provided for rock grading and quality, grout strength and penetration, and filter design and pressure relief measures. The grout mix should typically be designed for a strength of at least 3,000 psi, with maximum aggregate size of $\frac{3}{4}$ inch and a slump between 3 and 4 inches. Sand mixes may be used where roughness of the grout surface is undesirable. The finished grout should leave the face rock exposed for approximately one-quarter of their depth, and the surface of the grout should expose the matrix of coarse aggregate. The following construction details should be addressed in the specifications for effective grouted riprap lining:

- The prescribed method of riprap placement should prevent segregation of rock sizes, and the riprap should be wet immediately prior to commencing grouting operations.
- The prescribed method of grout placement should control segregation and uniformity.
- The prescribed method of grout placement should facilitate grout penetration by use of vibrating, spading and/or rodding.
- Quality control requirements during construction should be followed, including all material placement methods, grout mix design and strength testing, and recording of quantities of all materials. The volume of grout used should be compared to that required to meet penetration requirements.

9.7.3.2.4 Concrete-Lined Channels

Concrete can provide a continuous, rigid channel lining. Similar to grouted riprap, foundation conditions, hydrostatic pressure development and end treatments are design considerations that must be addressed. Offsets at joints may create additional hydrodynamic uplift forces. Reinforcing steel (No. 6 gage wire mesh or No. 4 reinforcing bars at 6-inch spacing are typical minimum recommendations for 4-inch and 6-inch lining thicknesses, respectively) to reduce the development of thermal stresses, shrinkage and flexural stresses within the Class A (AASHTO classification) concrete is normally provided. The FHWA (1989) provides guidance for design of concrete linings.

Filter layers should be placed below the concrete pavement, and weep holes should be employed to prevent the development of hydrostatic uplift pressures. The weep-hole configuration described above for grouted-riprap revetments should be the maximum spacing considered. Hydrodynamic uplift pressure may also be a consideration where vertical offsets or changes in channel slope occur,

particularly at transitions from a steep slope to a flatter slope. The USBR (2007b) presents results of testing for a range of flow velocity, joint widths, and offset dimensions and provides empirical estimates of hydrodynamic uplift as a function of velocity head. The USACE (1990b) presents guidance for analysis of vertical curve transitions and recommends that construction joints be excluded from sections transitioning from steep to flatter slopes. Other measures that may be considered include anchor systems grouted into rock or secured to deadmen.

Edge treatment at the toe, head, and terminal ends should be utilized to prevent undermining. Stub walls or cutoff walls are recommended at expansion joints.

9.7.3.2.5 Commercially Available Composite Erosion Control Products

Commercially available composite erosion control products include permanent reinforced vegetation mats; interlocking concrete blocks; grout-filled nylon mats (unanchored or anchored); soil, rock or concrete filled cellular confinement mats; gabion mats; cabled concrete or other similar products. The allowable tractive shear for these products will generally be specified by the manufacturer or can be determined by computer software developed by the manufacturer. The effectiveness of a particular type of channel lining relative to the intended use should be verified with the manufacturer prior to design. The FHWA (1989, 2005a) provides guidance for some commercially available products.

Applications of interlocking concrete blocks, grout-filled nylon mats, cellular confinement mats, and cabled concrete at coal refuse disposal facilities have included emergency spillway linings, groin ditches, principal spillway outlet channels, and diversion ditches where high velocities are present and excavation into rock is not possible. Design procedures are generally available from the manufacturers and these procedures should include methods for assessing tractive forces and uplift. For grout and concrete systems, additives such as steel or polyester fibers are sometimes employed to increase the strength of the concrete, decrease cracking, and to improve resistance to hydraulic wear.

Some design and construction issues for concrete and grouted riprap linings may also apply to composite systems, including:

- The foundation should be graded smooth and compacted to maintain support and prevent detrimental movement. Some composite systems require a filter and/or drainage layer beneath the lining.
- Side and end anchorages should follow manufacturers' recommendations, and when unusual site conditions are encountered, the manufacturer should be contacted for input.
- Weep holes must be provided where necessary, consistent with manufacturers' recommendations.
- Access to allow inspection and maintenance must be planned. If vehicles and equipment have to cross the channel lining, a reinforced section should be designed.

9.7.3.3 Cavitation

Cavitation of a hydraulic system occurs when flow separates from a containment surface. The result is the formation of a region of subatmospheric pressure that can lead to deterioration of the confining surface. Cavitation can occur in either open-channel or closed-conduit flow. As a rule of thumb, cavitation should be investigated whenever flow velocities exceed 35 feet per second (USACE, 1990b). The potential for damage is a function of flow duration and geometry and the abrasion resistance of the material.

In open-channel flow, cavitation can occur at steepening grade changes. At constructed ogees and paved channels, formation of a cavity of subatmospheric pressure can lead to damaging vibrations; under extreme conditions, these vibrations may actually displace the structure. In unpaved channels, cavitation can produce an upstream propagating erosion of the channel bottom that will worsen and possibly cause failure of the entire hydraulic system if uncorrected.

In closed conduits, cavitation most frequently occurs at sharp turns. For hydraulic systems common to coal refuse disposal facilities, this is particularly likely to occur at the transition from a drop inlet to the entrance of the transport conduit. Should the frequency and duration of high-velocity flow and conduit susceptibility to cavitation damage warrant, methods to prevent cavitation in closed conduits (USBR, 1987a) and USACE (1980, 1990b) may be needed.

9.7.3.4 Directional Changes in Open-Channel Flow

Methods for predicting the superelevation of the surface of curving flow are available, but the superelevation is usually small for subcritical flow velocities. When the flow at a curve is supercritical, a directional change is an exceptionally complicated problem because of the formation, propagation and combination of channel cross waves. These factors must be considered in design if channel overtopping is to be prevented. A simplified determination of the additional flow depth associated with superelevated flow at a rectangular channel bend is provided by the following equation (Chow, 1959):

$$\Delta h = \left\{ V_{max}^2 / g \right\} \left\{ (20/3)(r_c/b) - 16(r_c^3/b^3) + ((4r_c^2/b^2) - 1)^2 \ln[(2r_c + b)/(2r_c - b)] \right\} \quad (9-29)$$

where:

- Δh = change in depth associated with the superelevation (ft)
- V_{max} = velocity from Manning's equation in straight channel section approaching bend (ft/sec)
- r_c = radius of curvature measured to the centerline of the channel (ft)
- b = width of the channel (ft)
- g = gravitational acceleration = 32.2 ft/sec²

The FHWA (2005b) presents a method for estimating the superelevation of flow at bends in trapezoidal channels based on the velocity head. Additional guidance is provided in USBR (1987a) and USACE (1980, 1990b).

9.7.3.5 Directional Changes in Conduit Flow

Sharp directional changes and intersections in closed conduits cause static and dynamic thrusts that must be considered in design. Depending on the conduit size, the internal pressure and the flow velocity, thrust forces can cause the backfill surrounding the conduit to compress, and joints in the conduit can open or the deflection of the conduit can exceed the allowable pipe deflection due to the resulting movement. This is particularly a problem when the conduit location is shallow (or the conduit is supported above ground) and soil resistance to movement is low. Where thrust movements are identified as a potential problem, a concrete thrust block is often poured around the conduit to add mass and to distribute pressure over a larger area of soil. Discussions for evaluating the necessity of special construction measures at directional changes or intersections and procedures for analyzing requirements of thrust blocks are provided by Brater et al. (1996) and in engineering manuals from conduit manufacturers. The need for thrust blocks should be evaluated

for fittings such as tees and prefabricated bends and at directional changes where conduit joints could separate.

9.7.3.6 Materials Selection

The construction of any type of hydraulic system, and particularly a closed-conduit system, should not be undertaken without investigating the hydraulic and structural suitability of the proposed construction materials. This topic is discussed in [Section 9.3.3](#) and [Section 6.6.6.1](#) of this Manual. The discussion herein is for open-channel systems and culvert-conduit systems with emphasis on the importance of selecting materials that will function as intended and avoid costly repair or replacement. A detailed discussion of decant system material selection is presented in [Section 9.7.4.1](#) with specific attention to the structural integrity of the decant system due to embankment loading conditions.

9.7.3.6.1 Open-Channel Lining Systems

As part of the hydraulic design process, the suitability of the selected channel lining material should be determined. Material selection should be based on factors such as resistance to abrasion, the type of flow in the channel (continuous or intermittent), the acidic nature of the coal refuse, the impact that water quality characteristics may have on lining system integrity, the availability of the lining material, foundation conditions (particularly for more rigid lining systems), the constructability of the system (e.g., site topography and site access conditions), cost, and maintenance.

9.7.3.6.2 Conduit Materials

Culvert pipes can be corrugated metal (CMP); concrete; corrugated plastic (CPP), both smooth-wall or corrugated interior; high density polyethylene (HDPE); polyvinyl chloride (PVC); aluminum; steel or other materials. The type of material recommended is generally a function of intended use of the culvert (temporary or permanent), loading conditions, foundation conditions, construction limitations, and cost. Uncoated corrugated metal and steel are generally not recommended for long-term use in a mining environment because of the corrosion potential of mine water. Limited usage or protective coatings can make these material alternatives more acceptable.

Culverts constructed of concrete, CMP and aluminum are manufactured in various shapes (box, oval, arch, etc.) for installation in areas with limited height and clearance. Minimum and maximum cover height limitations are associated with all culvert installations. CPP and HDPE pipe are generally more flexible and structurally stable in conditions where minor settlements may occur.

In all applications, installation is critical to the structural integrity and hydraulic conveyance capabilities of conduits. The thickness of and installation procedures for bedding and backfill materials are critical to successful culvert construction. Joint connections in most culvert installations should be minimal. If joints are present, they should be soil-tight and in most applications watertight. Fusion-welded HDPE, gasketed joints for some concrete and CPP, glued PVC, and welded steel pipe provide the most watertight applications. Pressure testing can be performed to verify that joints are watertight.

9.7.4 Types of Hydraulic Systems

Sections 9.7.1, 9.7.2 and 9.7.3 have identified: (1) basic considerations for planning hydraulic systems at coal refuse disposal facilities, (2) the primary components of all hydraulic systems and techniques appropriate for their analyses, and (3) special design considerations associated with hydraulic systems. This section integrates this basic information into the following discussions of specific types of hydraulic systems most common to coal refuse disposal facilities.

9.7.4.1 Decant Systems

Decant systems at impounding disposal facilities serve one of the following three purposes or a combination thereof:

1. To remove clarified water during normal disposal of fine refuse.
2. To provide outflow during low-precipitation storms so that storage volume will be available if a large storm occurs.
3. To drain (possibly in conjunction with a spillway) the stored volume of inflow due to a large storm within a reasonable period after occurrence of the storm.

A decant system typically consists of: (1) an inlet section located in the impoundment at the elevation required for controlling or limiting the normal water surface level, (2) a transport section consisting of a closed conduit beneath or through the embankment, and (3) a discharge section located downstream from the embankment so as to minimize erosion of the embankment toe. It is the responsibility of the designer to select the optimum location for the transport section conduit and the discharge point, based on foundation conditions, conduit size and material, and discharge rates.

The optimal selection of the decant inlet type, configuration and location is primarily a function of the overall facility configuration, the required discharge capacity, the method for disposing of the fine refuse, the rate at which the impoundment level will rise during operations, and eventual abandonment or post-mining land use requirements. Design considerations include the height of the decant inlet invert above the settled fine coal refuse, the method of evacuation of clarified water between the decant inlet invert and the settled fine coal refuse level, the trash rack system for preventing debris from entering the decant pipeline, and the potential buoyancy of inlet and conduit.

Often the most challenging design consideration is selecting a conduit that will withstand the weight of the overlying refuse embankment and that can deform as the foundation and embankment materials settle vertically or displace laterally. Generally, only specially designed concrete, high density polyethylene (HDPE), or steel pipes are capable of withstanding the high pressures beneath a refuse embankment. [Section 6.6.6](#) provides guidance for the selection of decant materials and designing for embankment loading, including design of the decant pipe bedding and backfill. The transition from the riser to the transport section of the decant must be designed to handle the impact loads associated with directional change in flow. This is particularly important for rigid pipe systems, which are sensitive to movement. Control of seepage along and adjacent to the transport section of the decant, where it extends through the embankment, must also be addressed ([Section 6.6.2.3](#)).

To prevent erosion, the decant outlet must be able to accommodate the design flow rate and velocity. The rate and velocity of outflow must also be considered in the design of downstream conveyance and/or storage structures.

In the following sections, guidelines for the design of the hydraulic conveyance components of a decant system are presented. The inlet, transport and outlet sections of a decant system will be discussed separately. The discussion is based on the use of concrete, welded steel, and HDPE, since these are the most commonly used materials for impoundment decant systems.

9.7.4.1.1 Inlet

Location within the Impoundment

Location of the decant inlet within the impoundment is a function of the following factors: (1) site terrain and foundation conditions, (2) limitations of the transport section of the decant such as length and foundation conditions, (3) type of embankment construction such as upstream or

downstream construction, and (4) limitations in positioning the slurry discharge. Often, the inlet is positioned in the upstream portion of the impoundment, so that fine refuse can be deposited to form a delta at the upstream slope of the embankment and clarified water accumulates in the farthest upstream portion of the impoundment.

Trash Rack

The entrance to decant inlets should be protected by a trash rack. Even a partially obstructed pipe will have a substantially reduced capacity, thus increasing the potential for dam overtopping during a large storm event. Trash racks can become plugged if the openings are too small, and openings that are too large can result in the obstruction of the pipe due to the intake of large debris. The connection of the trash rack to the decant structure must be strong enough to withstand the hydrostatic and dynamic forces exerted on the trash rack during periods of high flow.

It is recommended that trash rack openings be sized so that they are a maximum of one-half the nominal dimension of the outlet conduit. The minimum opening size should be 6 inches by 6 inches or greater. The USBR (1987a) recommends that the area of trash rack openings be established based on the flow velocity through the rack. Where trash racks are inaccessible for cleaning, this velocity should not exceed 2 feet per second. A velocity of up to approximately 5 feet per second can be tolerated for racks that are accessible for cleaning. An anti-vortex device should be incorporated into the trash rack design to prevent the formation of a flow-inhibiting vortex during periods of high flow. The USBR (1987a) recommends that the anti-vortex device extend at least two diameters in front of and to each side of the inlet. In practice, these devices are usually part of the trash rack assembly and consist of a steel plate with width equal to the width (or diameter) of the rack.

Evacuation of Water below Riser Invert

As part of the design process, a sufficient minimum depth of water and associated height of riser above the settled fine coal refuse should be provided in order to prevent short circuiting of the impoundment and release of fine coal refuse slurry. This depth is frequently estimated based on experience and judgment, usually varying between 5 and 10 feet to accommodate settling of fine refuse in the slurry. Settling tests can be performed in the laboratory to aid in determination of the rate of settlement and the required impoundment retention time. The settling velocity can be determined from Stoke's Law based on the particle size and specific gravity of the fine coal refuse:

$$V_s = [g(S-1)D^2]/18\nu \quad (9-30)$$

where:

- V_s = settling velocity (cm/sec)
- g = acceleration of gravity (981 cm/sec²)
- D = diameter of particle (cm)
- ν = kinematic viscosity of fluid (cm²/sec)
- S = specific gravity of particle

The minimum height of the riser above the average settled fine coal refuse level can be calculated by determining the approximate detention time based on the outflow rate (slurry discharge rate plus watershed base flow) and impoundment geometry. To establish a balance between the detention time and period for settling, an iterative process is required. Because of the broad range in refuse particle sizes and varying impoundment geometry, experience and engineering judgment are generally used for determining the depth of water to be retained over the fine refuse.

Pumps are generally used to remove the clarified water below the riser invert. Such pumps should be capable of meeting the discharge requirement without increasing the flow rate through the settling zone sufficiently to cause removal of fine coal refuse.

Inlet Riser Pipe Buoyancy

Inlet riser pipe sections may be susceptible to the buoyancy forces sufficient to cause uplift, if the pipe weight and backfill height is not adequate. This is particularly a concern for steel and HDPE decant pipe inlets. Inlets to an HDPE decant pipe are generally installed in a trench extending up a natural hillside with the inlets located at specified elevation intervals. Sufficient fill or anchorage must be provided to overcome buoyant forces, with a recommended factor of safety of 1.5.

Extension of Inlet

The decant riser inlet elevation is generally established based on storm routing such that adequate impoundment freeboard and surcharge storage is provided. As a refuse embankment dam is raised to increase the capacity of the impoundment, the riser inlet is correspondingly raised to provide additional slurry disposal capacity. If the decant system has multiple risers, the lower riser is sealed and abandoned and the next upper riser is put into service. Extension of an inlet will require that the connection, extension, and new inlet section be designed to accommodate the flows and related forces associated with continuing operation. If the decant system is designed with multiple risers, sealing (such as by employing a bolt-on plate) and abandonment (such as by embedment in concrete) of the riser must be part of the design. To assess the potential for additional stress and deflection at the base of the sealed riser, the loads associated with abandonment (along with future embankment construction) must be evaluated.

In some instances where high embankments are required and there are concerns about pipe loading, designers have limited the service life of a decant inlet and transport pipe section by abandoning the entire system and installing a second system at a higher elevation. In such situations, the original inlet and transport section should be sealed and abandoned upon completion of the replacement system.

9.7.4.1.2 Transport Section

The transport section of the decant pipe must typically be watertight and must include seepage control structures to intercept the flow of seepage along and adjacent to the conduit where it extends through the refuse embankment. For these reasons, structural considerations based on the external loading generally govern the design of this portion of the decant once the diameter has been established. Determination of external loading conditions and structural design of a decant pipe are addressed in [Section 6.6.6](#).

Rigid pipe used within a refuse embankment is typically concrete pressure pipe because of the large external loads and the requirement that the pipe be watertight. Concrete pipe is rigid and sensitive to differential settlements, particularly at the inlet-riser transition, resulting from directional flow impacts, foundation conditions, or imposed embankment loading conditions.

Infiltration and exfiltration leakage problems can develop within the transport section of the decant pipe. Irreparable damage of the pipe and possibly failure of the refuse embankment can occur if such leakage is undetected. As part of the installation process, project specifications should require that pipes installed within the limits of the impounding refuse embankment be pressure tested prior to backfilling so that detected leaks can be immediately repaired.

Joint tightness is also a concern in non-pressure pipe installations, such as in the upstream inlet section of the decant pipe or in a concrete riser extension. Infiltration or exfiltration at joints could impact the pipe backfill if the material is erodible. Testing of non-pressure pipe joints is recommended.

Flexibility, watertightness and relatively easy installation procedures have led to the use of HDPE for decant pipes. Structural evaluation procedures associated with the flexible conduit under large embankment loads are presented in Section 6.6.6. For flexible pipe, both structural and hydraulic design considerations may control the decant pipe size. Thus, evaluation of the embankment loading and required wall thickness of the pipe should be performed in parallel with the hydraulic design.

Schematic examples of decant inlets that are most adaptable to coal refuse disposal facilities are illustrated in [Figure 9.38](#), while illustrations of actual decant systems that have been constructed are shown in [Figures 9.39](#) and [9.40](#). The primary advantage of the inlet types shown in [Figure 9.38a](#) through [d](#) is their access for expansion as the level of settled fine refuse increases. The primary disadvantage is that the length of conduit required upstream of the embankment, beneath the settled slurry, is relatively great. The length of conduit in the [Figure 9.38a](#) and [c](#) decant systems is particularly significant because it must be as long as the entire impoundment. However, an advantage of these systems is that the inlet is located at the point where the water depth is normally the greatest (when the slurry is discharged at the embankment end of the impoundment), allowing the decant system to drain the water without pumping.

The inlet shown in [Figure 9.38d](#) appears to be the simplest arrangement because it offers the shortest conduit length and the inlet can be extended in height by adding subsequent sections as the settled fine refuse level rises. Major difficulties with this type of decant system are: (1) its location within the impoundment, which makes access very difficult, and (2) large impact forces at the point of directional change from the inlet to the transport section. With regard to the latter, the effect of forces due to falling water must be accounted for by providing a curved section at the base of the vertical riser and/or constructing a concrete pad to distribute impact loads to the underlying soils.

[Figure 9.39](#) presents an example of a decant system installed at a diked-impoundment facility. In this example, a flexible pipe serves as the decant with the riser extending vertically up into the impoundment. A water return line to the coal preparation plant is installed parallel to the decant line, and the impoundment water level is controlled by a pumping system. The decant inlet is positioned so as to provide for storage of the design storm runoff, which for a diked impoundment is predominantly the precipitation falling upon the impoundment surface. Note that the water return line, as would the case for any conduit passing through the embankment, must be designed with seepage control measures.

[Figure 9.40](#) shows an example of a decant system installed at a cross-valley impoundment, where multiple risers, or inlets, extend from the transport section of the flexible pipe. In this example, a pumping system is used to maintain the impoundment water level, and the decant serves to rout significant storm runoff through the facility. As the settled slurry accumulates within the impoundment, the lower riser inlet is sealed and the next upper riser inlet is fitted with a trash rack for operation. In the example system shown in [Figure 9.40](#), a seepage interception zone has been installed within the backfill for the decant system.

9.7.4.2 Overflow Spillway Systems

When the design storm is not stored in the impoundment at coal refuse disposal facilities, overflow spillways that protect downstream life and property by safely discharging the accumulated runoff from large storms are the most crucial hydraulic systems. They frequently must be designed to convey substantial flows over steep terrain. The vital importance and design complexity of these structures combined with the complications of a constantly changing embankment configuration, dictates that spillways for coal refuse disposal facilities be viewed differently than spillways for other types of impoundments.

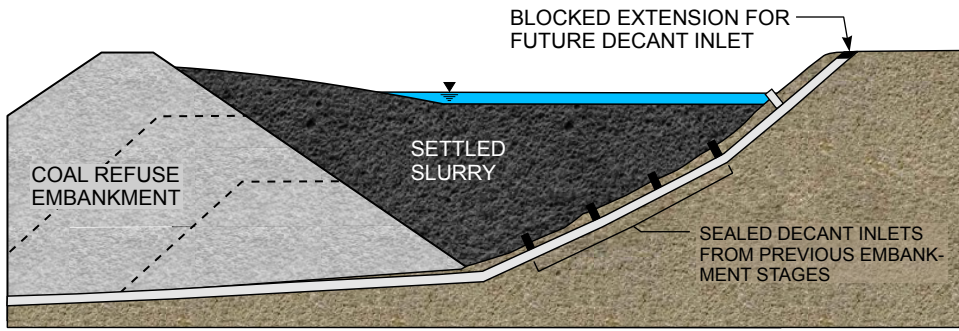

9.38a DECANT INLET ON SLOPE AT SIDE OF IMPOUNDMENT

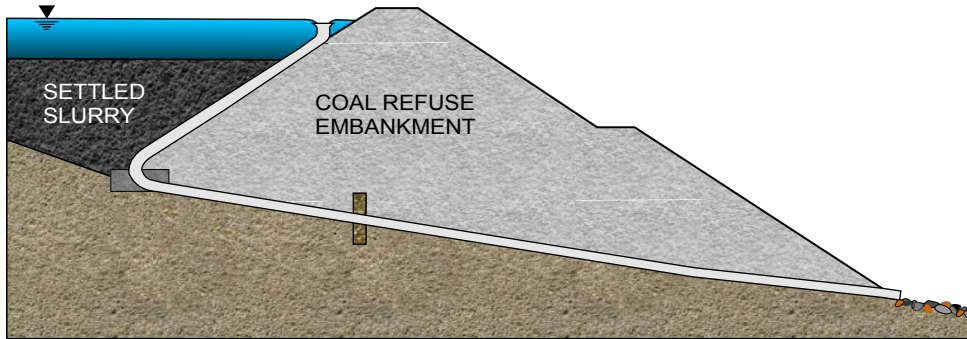

9.38b DECANT INLET ON EMBANKMENT SLOPE

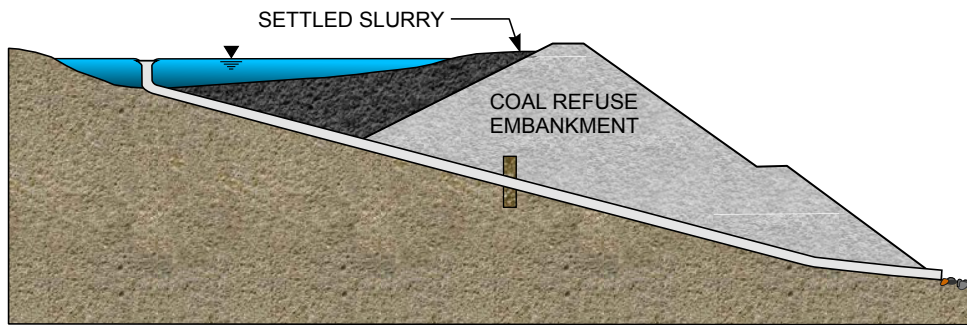

9.38c DECANT INLET AT UPSTREAM END OF IMPOUNDMENT

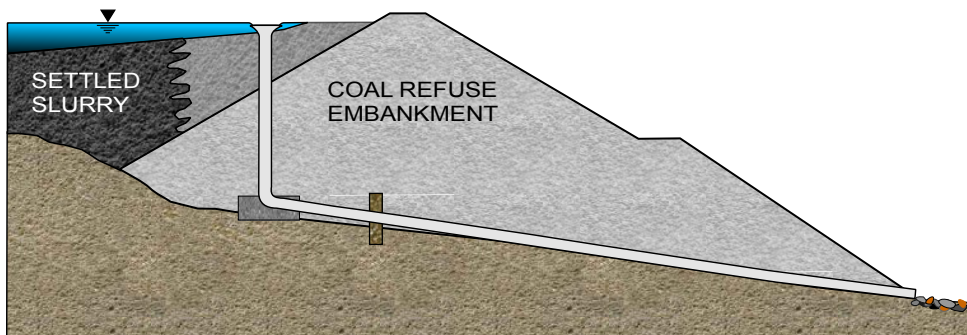

9.38d VERTICAL DECANT INLET

FIGURE 9.38 EXAMPLES OF DECANTS

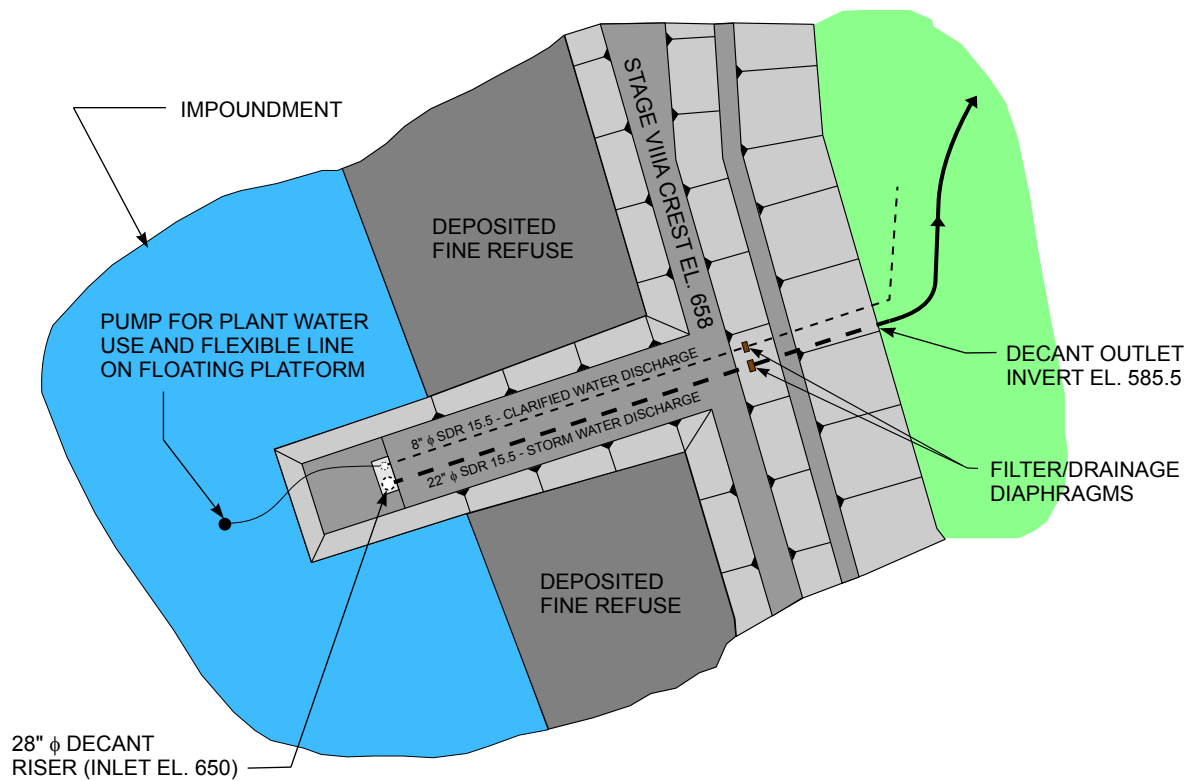

9.39a PLAN

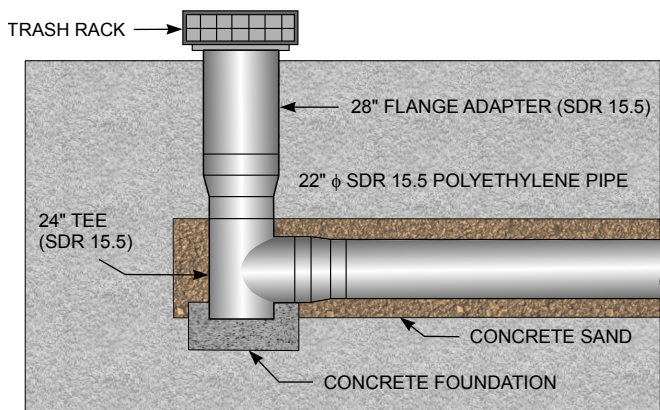

9.39b DECANT RISER DETAIL

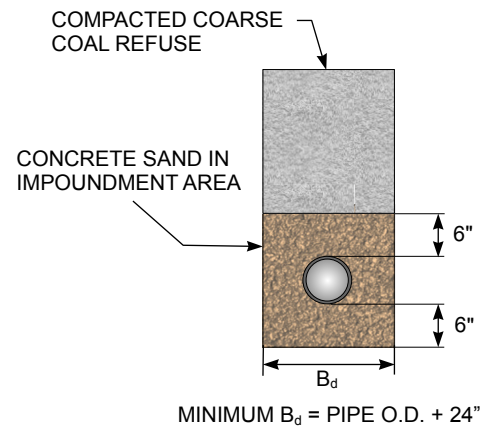

9.39c TRENCH DETAIL

FIGURE 9.39 EXAMPLE DECANT SYSTEM AT DIKED IMPOUNDMENT

Most transport sections for open-channel spillway systems at impounding disposal facilities are channels excavated into an embankment abutment. Erosion protection should be provided if the abutment materials in the excavated channel are not durable and could erode, creating stability concerns. The spillway channel should extend to a point downstream of the embankment and be appropriately lined and have sufficient freeboard to protect the embankment. Examples of spillways that have been constructed at impounding disposal facilities are illustrated in Figures 9.41 through 9.43.

Figure 9.41 illustrates a condition where a spillway channel was constructed in an existing valley fill and side hill embankment, necessitating a variety of channel configurations and linings. Concrete and grouted riprap materials were used in steep channel segments and at changes in flow direction.

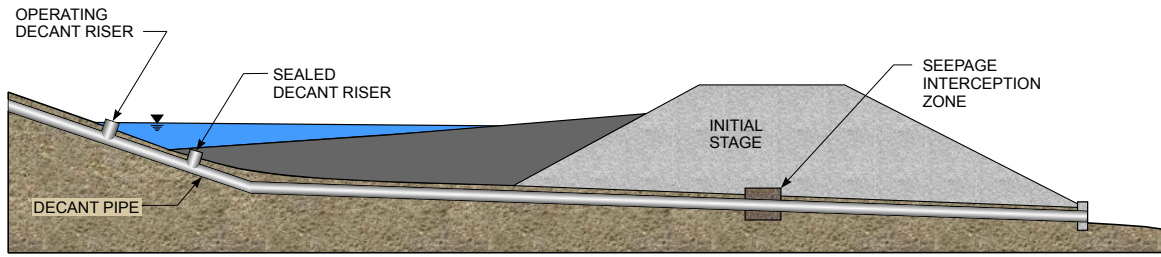

9.40a PROFILE

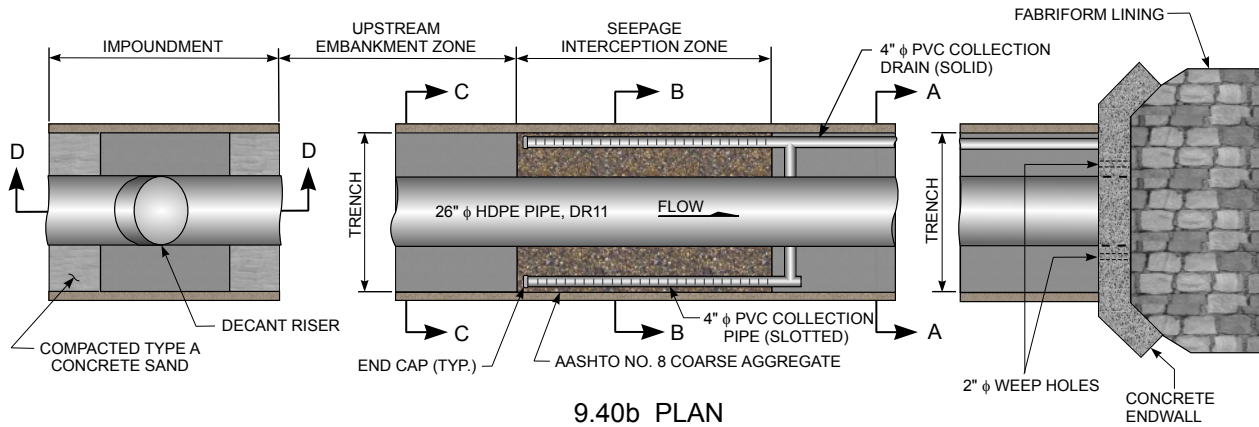

9.40b PLAN

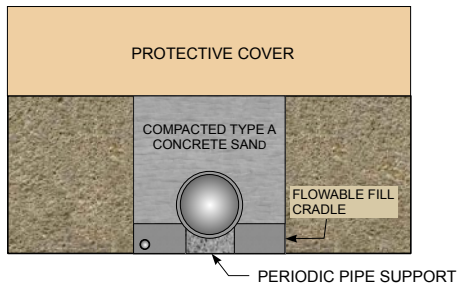

9.40c SECTION A - A

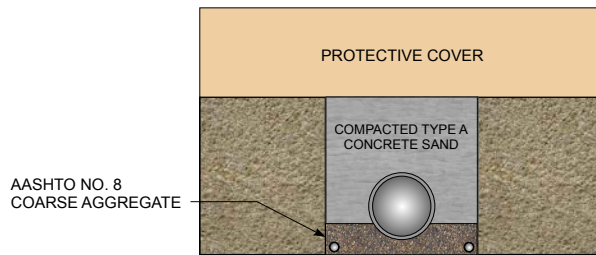

9.40c SECTION B - B

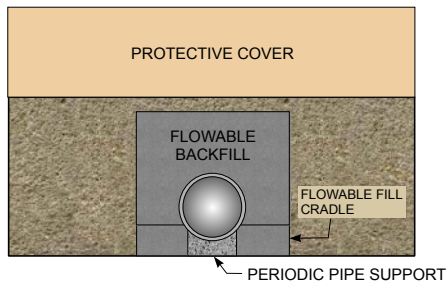

9.40e SECTION C - C

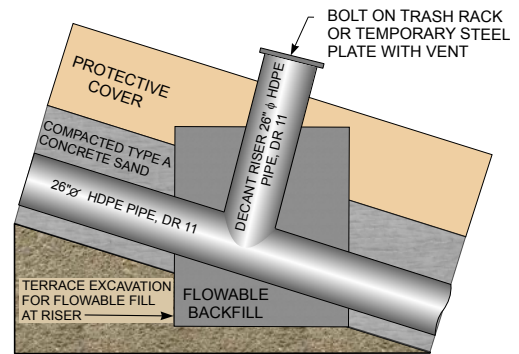

9.40f SECTION D - D

FIGURE 9.40 EXAMPLE DECANT SYSTEM AT CROSS-VALLEY IMPOUNDMENT

Figure 9.42 illustrates a condition where the height of the natural abutment for a new refuse embankment was only slightly higher than the planned embankment crest. A spillway was constructed by making an excavation through the abutment so that storm flows would discharge into an adjacent valley and the refuse embankment would not be endangered.

Figure 9.43 illustrates a cascade spillway system. A new spillway at the higher elevation was excavated into a hillside to direct flow to a point above the beginning of the lower spillway. The plunge pool in the lower spillway dissipates the energy of the cascading water and turns the direction of flow downhill and away from the embankment.

The design capacity for spillway systems is usually determined by the reservoir routing procedures presented in Section 9.8. Spillway design involves selecting the control location and method to achieve the required flow capacity while fully utilizing the available storage capacity.

Figures 9.44 and 9.45 show typical inlet and outlet controls for spillway systems. To determine the most appropriate control for a particular situation, the following factors should be considered:

Inlet Control – Inlet control for spillway systems is desirable when it is important to minimize the size of the transport channel, including the following situations:

- The length of the channel downstream from the inlet that can be economically constructed is limited (flow will be supercritical downstream from the inlet).
- The area for construction of a downstream transport section is limited due to terrain instability (hilly and steep terrain).
- Substantial storage capacity is available in the impoundment and economies can be realized by reducing the size of the transport section or channel (encountered at some large facilities sited in long valleys).
- Competent, erosion-resistant material is available at the inlet of the system but not at the outlet (inlet control is more easily accomplished).

Outlet Control – Outlet control for spillway systems is desirable when it is important to minimize the velocity of flow or the grade of the transport section, including:

- The upstream flow in the transport section must be maintained at subcritical velocities to minimize erosion of soft channel materials. An overflow weir located at the downstream end of the transport section or channel can be used to create this condition.
- Competent materials that provide erosion resistance are present at the outlet.
- A natural overfall occurs at the outlet, where the water discharges by free fall without causing significant damaging erosion.

Regardless of the point of control, the primary requirement of spillway system design is that the discharged flow not adversely affect the safety of the overall coal refuse disposal facility. Section 9.7.2.3 discusses the types of outlets available for either safely discharging the flow away from the facility or for dissipating the flow energy with a stilling basin. Generally, the spillway discharge point is located a sufficient distance away from the embankment so that a special hydraulic structure is not required. The examples illustrated in Figures 9.41 and 9.43 show excavated channels discharging onto steep slopes. The major design issue for this approach concerns the frequency and severity of damage that might result from such discharge. Discharges should be rare occurrences, and damages should be limited to surface erosion of the steep slope without adverse impact to the disposal facility embankment. Also, the discharge point and slope should be within mine property ownership and not be

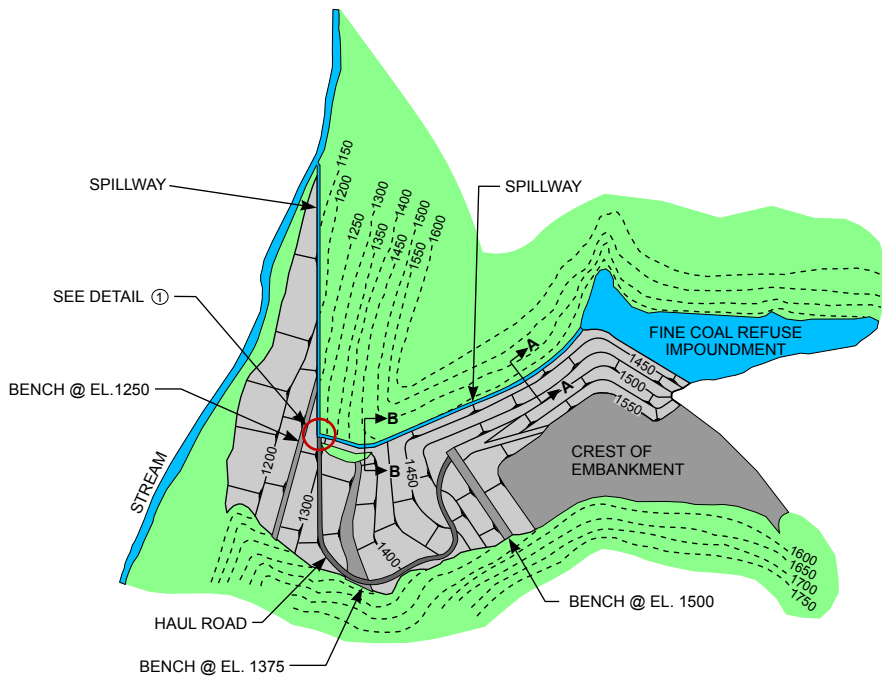

9.41a PLAN

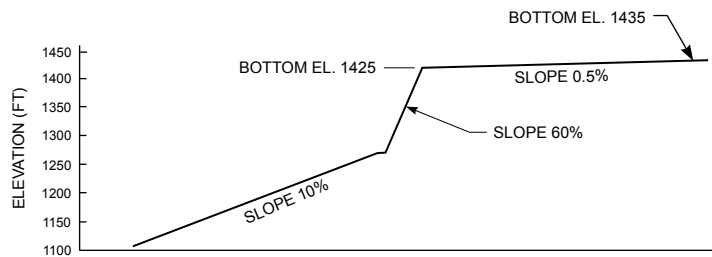

9.41b SPILLWAY PROFILE (NTS)

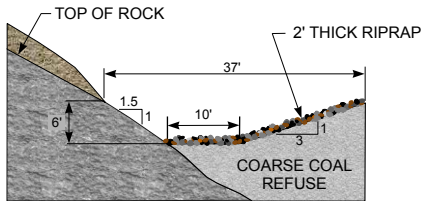

9.41c SECTION A - A

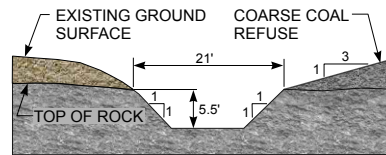

9.41d SECTION B - B

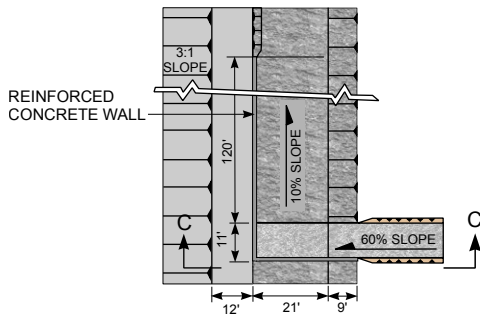

9.41e DETAIL 1

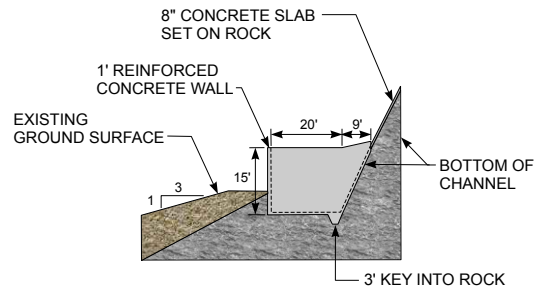

9.41f SECTION C - C

FIGURE 9.41 EXAMPLE SPILLWAY SYSTEM – A

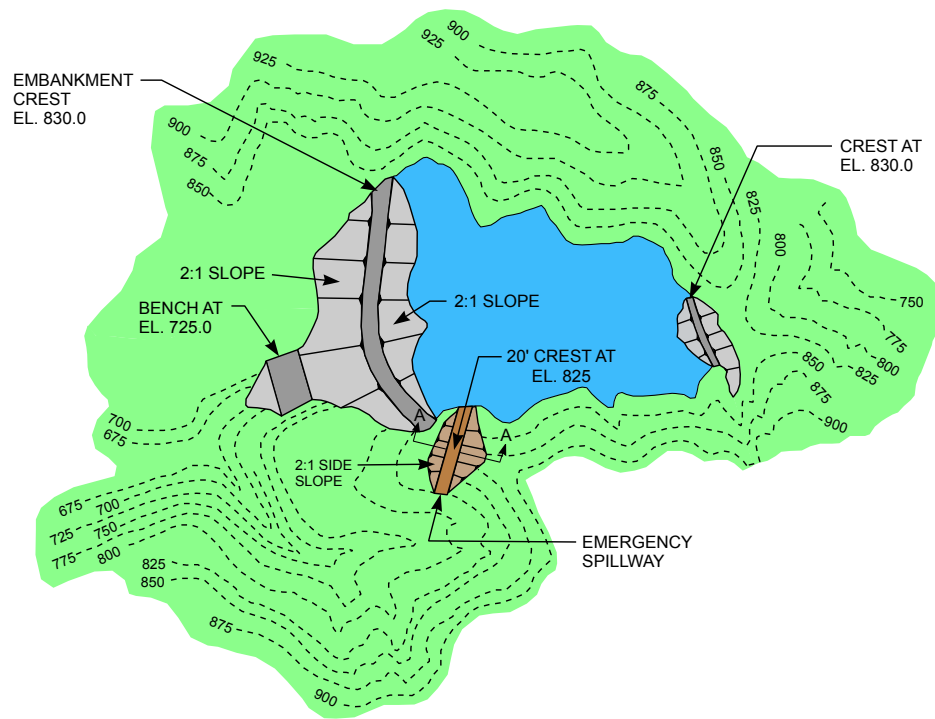

9.42a PLAN

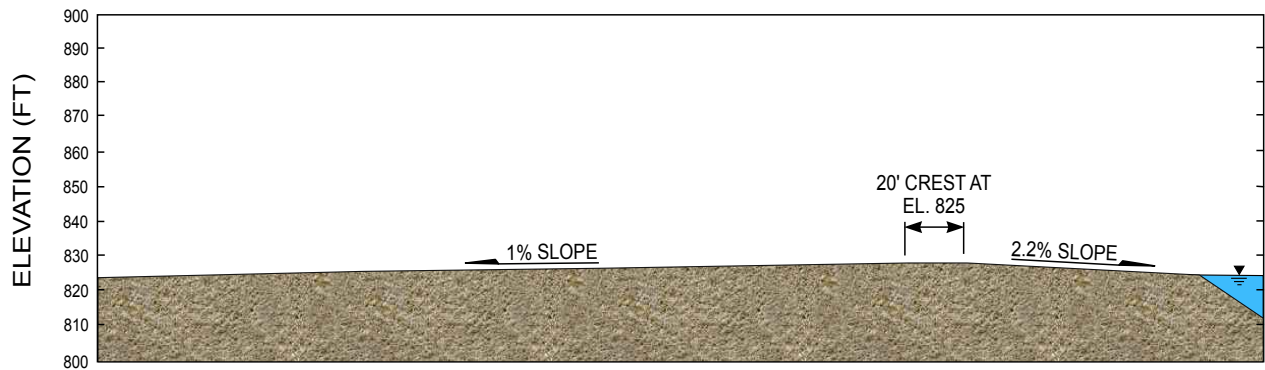

9.42b SPILLWAY PROFILE

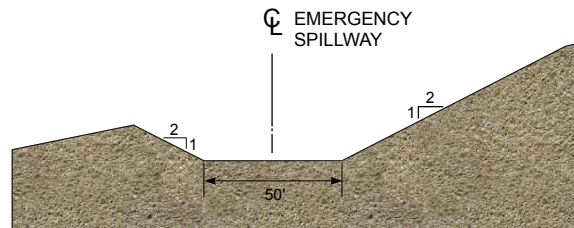

9.42c SECTION A - A

FIGURE 9.42 EXAMPLE SPILLWAY SYSTEM – B

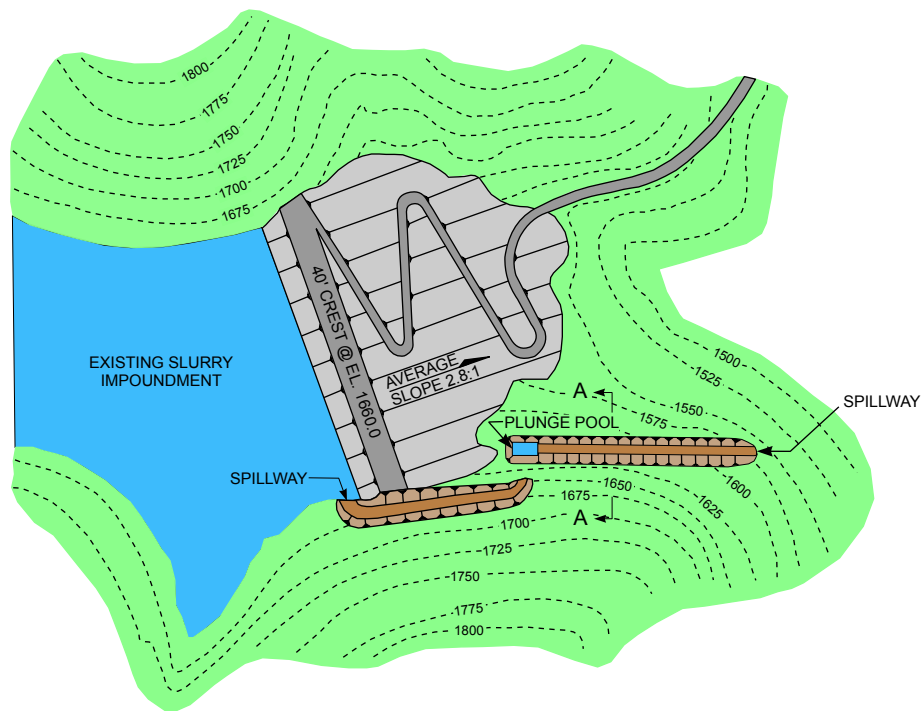

9.43a PLAN

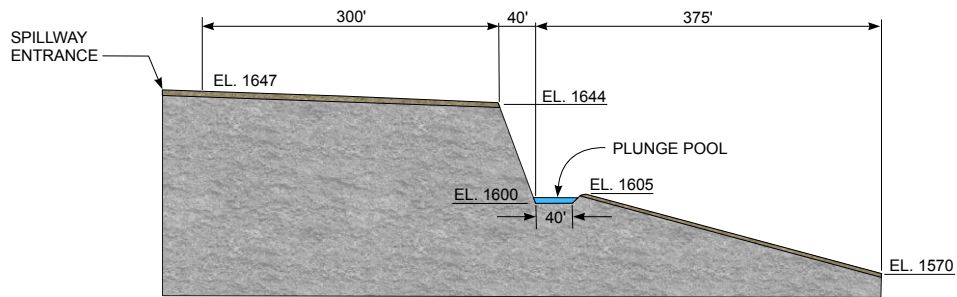

9.43b SPILLWAY PROFILE

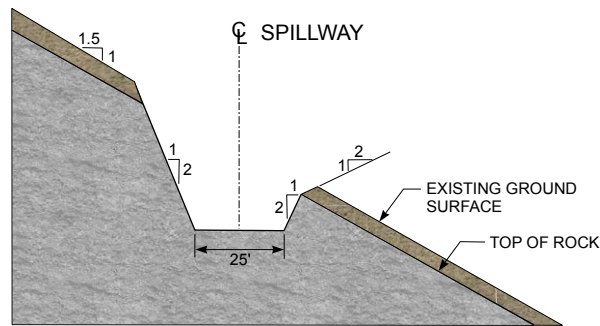

9.43c SECTION A - A

FIGURE 9.43 EXAMPLE SPILLWAY SYSTEM – C

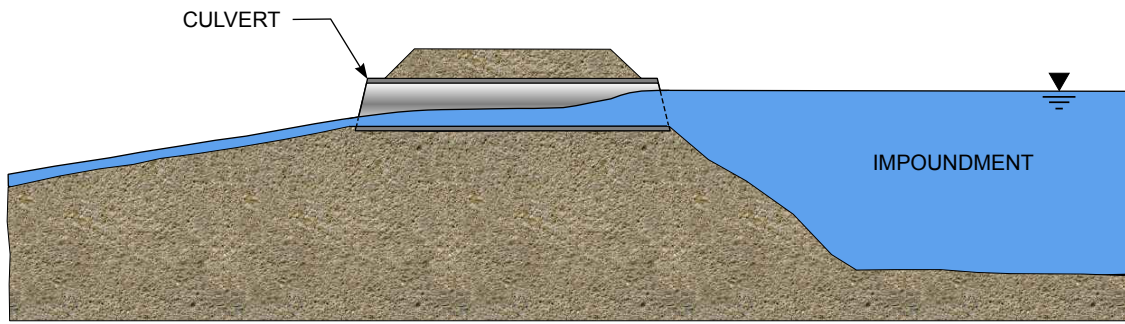

9.44a CULVERT INLET CONTROL

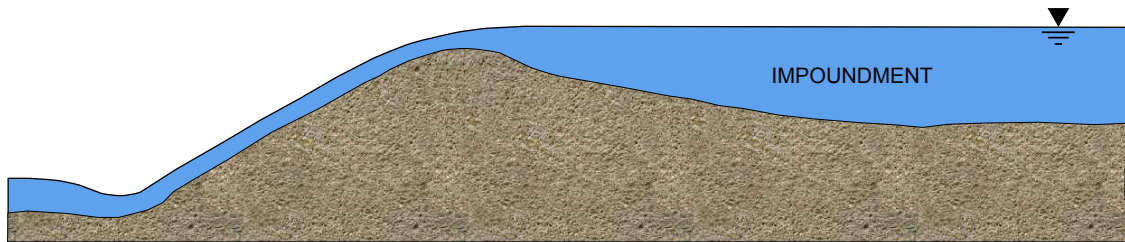

9.44b INLET TO STEEP CHANNEL CONTROL

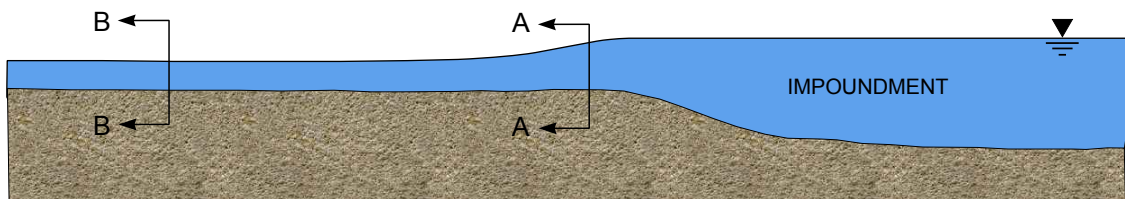
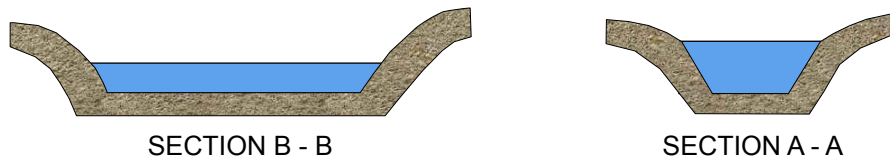

9.44c NARROW INLET CONTROL

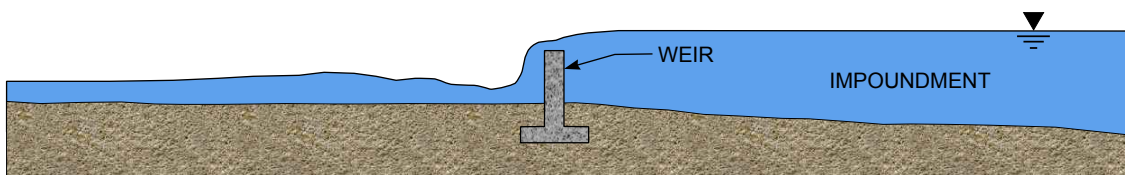

9.44d WEIR INLET CONTROL

FIGURE 9.44 SPILLWAY INLET CONTROL

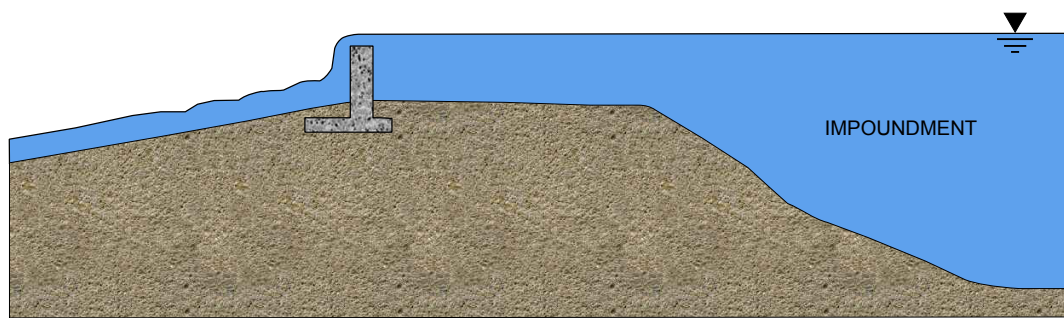

9.45a WEIR OUTLET CONTROL

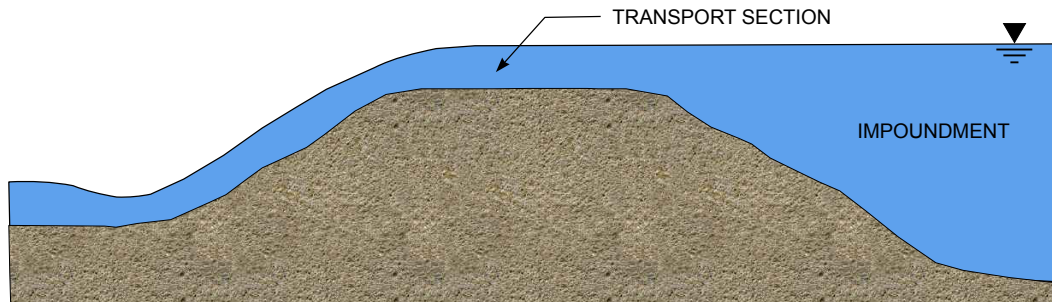

9.45b OUTLET TO STEEP CHANNEL CONTROL

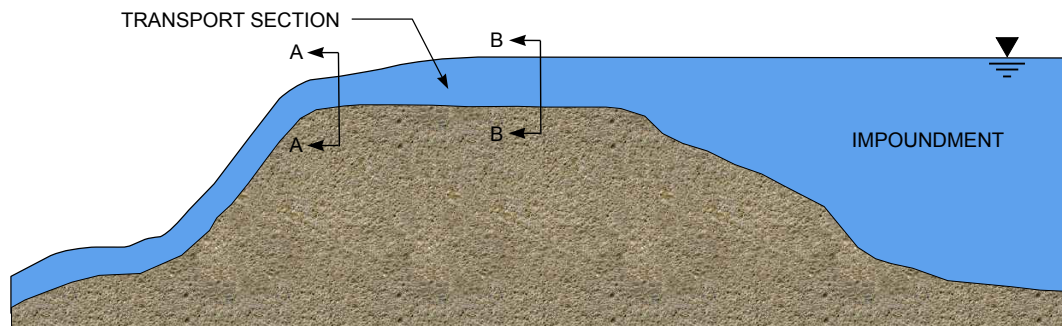
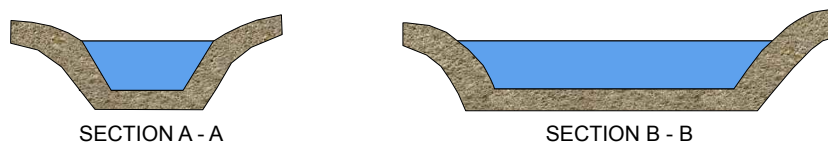

9.45c NARROW OUTLET CONTROL

FIGURE 9.45 SPILLWAY OUTLET CONTROL

upgradient from structures or public transportation facilities. More difficult to evaluate are property and/or environmental damages that might occur below the discharge point due to vegetation loss, surface erosion and even local landslides. The following criteria are suggested as design guides for preventing impacts to a disposal facility embankment when the discharge of open-channel spillways onto slopes is contemplated:

- If the spillway will only be activated during very large storms (i.e., on the order of the PMF), special provisions are seldom required at the outflow point because the resulting erosion damage typically will not be significantly greater than the erosion

damage that would have occurred anyway, and the probability of the spillway functioning many times during the operational period of the facility is low.

- If the spillway is expected to be activated as often as every 25 years or more frequently, special provisions should be made to transport the flow without excessive erosion, or the flow should be discharged through a separate system.

High velocity flow in open channels represents a significant source of energy that must be controlled for safe water conveyance. Special considerations for the design of excavated channel spillway systems include:

- Initial planning and design should account for the manner in which the spillway system may need to be extended or modified as the disposal facility increases in size.
- The channel materials (natural or constructed) must be resistant to erosion ([Section 9.7.3.1](#)).
- The stability of the excavated slopes forming the channel must be evaluated ([Section 6.6.5](#)).
- Potential erosion at directional changes, particularly during supercritical flow, must be evaluated and accounted for in the channel design ([Section 9.7.3.3](#)).
- Rigid spillway linings must be designed to resist the development of hydrostatic and flow-induced uplift pressures.
- Sufficient freeboard to contain the discharge within the spillway channel must be provided.

An important consideration in the design of rigid spillway linings is uplift pressures. For spillways with rigid lining, uplift is typically estimated based on the hydrostatic head associated with the normal pool level applied at the upstream end, varying linearly to the hydrostatic head associated with the downstream flow depth (tailwater) level. Where there is a potential for open, offset joints in steep spillway chutes, the velocity may be converted to dynamic pressure. While the theoretical maximum dynamic pressure should be calculated (e.g., the stagnation condition where all velocity is converted to pressure), surface effects will limit the dynamic pressure. The USBR (2007b) presents the results of testing for a range of flow velocities, joint widths, and offset dimensions, which is intended to be a refinement of the estimation of associated potential uplift forces where open joints are a concern. However, the uplift associated with the impoundment level must be estimated separately based upon site-specific conditions. For example, the uplift pressure for dynamic forces is typically 50 to 75 percent of the stagnation pressure for joint offsets ranging between $\frac{1}{8}$ and $\frac{3}{4}$ inch (e.g., at an average flow velocity of 35 feet per second, measured pressure was approximately 10 feet of head as compared to a 14-foot stagnation value for a $\frac{1}{2}$ -inch offset and $\frac{1}{4}$ -inch joint). Such uplift forces should be considered in situations where lining failure would trigger impoundment failure. Measures for reducing or controlling the potential development of uplift pressures include:

- Grouting to control foundation seepage, where applicable.
- Installation of an underdrain system consisting of perforated pipe within a graded sand and gravel filter to control seepage.
- Use of rigid foam insulation between the concrete spillway and underdrain system to prevent freezing in cold climates.
- Installation of embedded waterstops in floor joints to prevent the flow of water through the joints to the foundation.
- Use of longitudinal reinforcement and transverse cutoffs at joints to prevent relative displacement.
- Increasing the weight of the channel lining.

For channels on rock foundations where the above measures may not be effective, structural design of the channel lining with anchors to resist uplift pressure should be employed.

9.7.4.3 Diversion and Collection Ditches

Diversion and collection ditches are important because the collection and control of runoff from a refuse embankment surface, from the slopes of an embankment, and from hillsides draining to and away from the embankment should minimize environmental damage to downstream waters, prevent damage to the embankment, and reduce maintenance and repair efforts related to site erosion. This is particularly true when a refuse disposal facility is reclaimed and the drainage facilities must function with limited repair for a long period of time. Basic procedures for designing diversion and collection ditches are the same as those for other types of channels, as discussed in [Sections 9.7.1](#) and [9.7.3](#).

The following are the most important considerations in the design of drainage channels:

- Diversion ditches should be designed to reduce the amount of water reaching the disposal facility during moderate storms when it can be shown that they will appropriately reduce operating or environmental concerns. It is seldom practical to design diversion ditches that will not fail during very large storms such as the PMF.
- The constantly changing size and configuration of refuse disposal facilities often makes it necessary to provide short-term runoff diversion and collection ditches at intermediate development stages. Erosion protection criteria for these structures must be established on a case-by-case basis and may differ from the erosion protection procedures for more permanent ditches and channels.
- When a diversion or collection ditch will later serve as a permanent channel, the capacity and type of erosion protection material should meet the requirements for the permanent installation.
- When a collection ditch will also serve to route the design storm discharge from an impoundment outlet (by receiving the discharge from a decant or open-channel spillway), its capacity and durability should be based on the impoundment design storm. In this instance, the concern is that the collection ditch must be able to function without damage to the integrity of the embankment for storms up to the impoundment design storm.

9.7.4.4 Culverts

Culverts are typically used beneath access roads that permit runoff from minor storms to pass without loss of road use. The appropriate design storm for such culverts depends on the importance of the roadway to the overall operation and the effort and cost of repairing the road if it is overtopped or washed out. An exception might be a roadway to an impounding embankment that must remain open during or immediately following a large storm. However, the design criteria established for impoundments in [Section 9.5](#) are based on the assumption that it is not practical to maintain access to the impoundment during that time period.

The basic design requirements for culverts were previously discussed in [Sections 9.7.1](#) and [9.7.2](#).

9.7.4.5 Natural Streams

A natural stream flowing adjacent to a coal refuse embankment can cause significant damage if the water at flood elevation can reach the refuse embankment toe and cause erosion. Flow in natural streams can be determined based on the principles of open-channel flow ([Section 9.7.2.2](#)), although the analysis to determine maximum flow depth may be more involved due to the irregu-

lar cross sections of natural streams. Computer software for estimating the flood levels along natural streams is readily available.

As with constructed channels, the flow in a stream can be controlled by upstream or downstream conditions, depending on the stream slope, configuration and discharge. Normally, the flow may be assumed to be uniform and Manning's equation (Equation 9-17 or 9-18) can be used to approximate the flow depth and velocity, except immediately upstream of bridges, road embankment crossings, natural channel constrictions, etc. that cause backwater effects requiring the use of open-channel profile analysis for determination of flow depth and velocity. The roughness coefficient n for natural streams may be in the higher ranges shown in Table 9.13 due to vegetation including trees, variations in alignment, and the irregularity of cross sections. The hydraulic radius can be calculated in a manner similar to that for a constructed channel, except that the areas and wetted perimeter must be determined from topographic maps or cross-section drawings.

Based on the peak runoff to a natural stream, the approximate water depth can be calculated. If the computed flow depth indicates that the water in the stream could encroach upon the refuse embankment toe, provisions to prevent embankment erosion or disruption of the facility hydraulic system should be employed.

9.8 RESERVOIR ROUTING

As part of the design of the hydraulic system for an impounding refuse disposal facility, reservoir routing analyses are typically performed to determine the outlet spillway discharge and impoundment storage requirements. This is critical for open-channel spillway systems, but is also important for sites that rely on storage of the design storm and discharge of the runoff through the decant, because these facilities have 10 days to discharge the storm inflow in accordance with the criteria presented in Section 9.5. The methodology and key parameters for routing analyses are described herein, and references to the computer software typically employed are provided. For specific applications, frequent reference is made to texts and publications on hydraulic design and engineering such as Chow (1959), USBR (1987a), and the USDA *National Engineering Handbook* (1956).

9.8.1 Basic Routing Methodology

Reservoir routing is performed by analyzing the inflow hydrograph (Section 9.6), the storage capacity of the impoundment (Section 9.7), and the discharge-head relationship for the spillway outlet (Section 9.7) to determine the reservoir level and spillway outflow hydrograph. The spillway outlet may consist of a conduit system (decant or principal spillway), emergency open-channel spillway, or a combination of conduit and open-channel spillway. Flood routing analyses should be based upon an initial impoundment water level no lower than the lowest functional decant inlet. For impoundments that rely solely on a conduit system, the majority of the runoff from the design storm must be stored within the impoundment because of the limited discharge capacity of the conduit. However, the conduit must be capable of discharging 90 percent of the runoff within a 10-day period following the design storm.

Impoundments with an emergency open-channel spillway generally have significant discharge capacity, and thus less of the design storm runoff must be stored within the reservoir. The open-channel spillway inlet will be above the normal pool level, such that some initial storage or accumulation of runoff from the inflow hydrograph occurs before outflow through the open-channel spillway is initiated. Subsequently, the spillway discharges at a rate dependent on the reservoir level, which in turn is a function of the inflow hydrograph and storage capacity. After the peak of the inflow hydrograph passes, the reservoir level will continue to rise until the inflow rate and spillway outflow capacity are equal. Thereafter, the reservoir level will decline as spillway discharge becomes predominant. This relationship is shown in the hydrographs presented in Figure 9.3. The development of the reservoir-

storage relationship is discussed in [Section 9.6.1.4](#), and the spillway-discharge relationship is discussed in [Section 9.7.2](#).

USBR (1987a) and the USDA *National Engineering Handbook* (1956) present mathematical procedures for computation of flood routing, using an iterative process to arrive at the outflow hydrograph. Computer programs such as HEC-1 and HEC-HMS are frequently employed to perform the routing analysis USACE (1998b, 2000).

9.8.2 Basic Routing Parameters

An important factor that differentiates coal refuse disposal facility impoundments from other types of impoundments is that the embankment and impoundment configurations continually change with both the disposal of coarse refuse on the embankment and the disposal of fine refuse slurry into the impoundment. These effects must be accounted for in the hydraulic design and reservoir routing for a refuse disposal facility.

Figure 9.46 presents a sectional view of an impoundment facility illustrating features that impact the routing of floods and the development of design parameters, including normal pool elevation, minimum pool level, surcharge storage, normal freeboard and design-storm freeboard.

The design-storm freeboard for an impounding embankment is a function of the wave height and the wave run-up conditions at the upstream face of the embankment. Guidance for the evaluation of design storm freeboard for reservoirs is presented in USBR (1987a). Coal refuse impounding embankments are typically required to have a minimum design storm freeboard of 3 feet above the maximum reservoir pool level associated with the design storm, consistent with a fetch of less than 1 mile.

Since the crest elevation of a slurry impoundment can change frequently, the facility plans and specifications should include a graph or table that shows the maximum allowable normal pool level and allowable spillway and decant levels for each stage of operation. To ensure that adequate freeboard is available to handle the design storm, the normal pool level and spillway inlets must not be raised until the appropriate crest elevation has been reached. The disposal of fine coal refuse within an impoundment affects the reservoir storage capacity. While most of the accumulation occurs below the impoundment operational water level, the slurry discharge results in the build-up of deposits forming “deltas” or “beaches” above the pool level. While this impact is frequently insignificant for many valley-fill type impoundments, it can have an impact on routing and freeboard particularly at diked-type facilities. This loss of storage capacity is generally estimated based

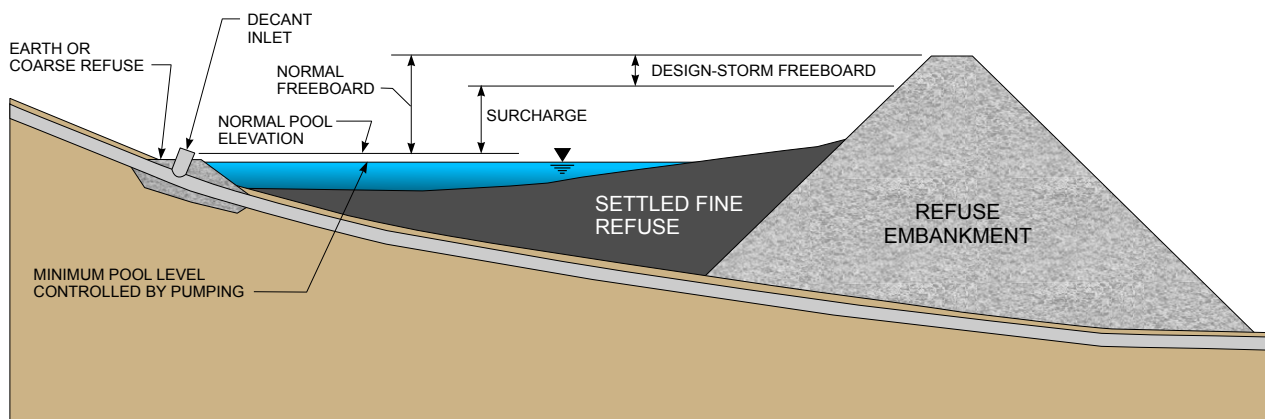

FIGURE 9.46 SECTIONAL VIEW THROUGH IMPOUNDING FACILITY

upon the position and elevation of the planned slurry discharge and an assumed slope of the deposit (typically between 1 and 3 percent).

9.9 DAM BREACH ANALYSIS AND INUNDATION MAPPING

9.9.1 Background

Impoundments are assigned a hazard-potential classification based on the consequences to downstream workers, residents and property in the event the dams were to fail. FEMA (2004a) classifies dams as “high hazard potential,” “significant hazard potential,” or “low hazard potential,” and the states typically have comparable classification systems. A high-hazard-potential dam or embankment is one whose catastrophic failure would likely result in loss of human life. A significant-hazard-potential dam or embankment is one whose failure would not be expected to result in the loss of human life, but could cause substantial property damage. Minimal property damage would be expected from the failure of a low-hazard-potential dam or embankment. As discussed in [Section 3.1](#), MSHA requires evaluation of the hazard potential for other impoundment breach pathways, such as breakthrough into underground mines.

In practice the hazard-potential classification for a dam may be apparent from site conditions; for example, a large impoundment located upstream from a populated area will likely be classified as having a high hazard potential. To aid in determining the hazard-potential classification and to assist in preparation of an Emergency Action Plan, a dam-breach analysis is performed to determine the downstream consequences of a dam failure.

An EAP should be prepared for high- and significant-hazard-potential dams and embankments, so that procedures are in place for responding to an emergency at the dam and to conditions in the potentially-inundated area downstream (Chapter 14.0). This is a requirement in several states, and MSHA encourages EAP preparation for high- and significant-hazard-potential dams in order to protect the public that would potentially be affected by a dam failure (MSHA, 2007). An important step in the preparation of an EAP is to perform a dam-breach analysis so that the potentially-inundated area downstream from the dam or refuse embankment can be defined. Scenarios for dam failure, methods of analysis, software used for analysis, data requirements, and other aspects of the dam-failure flow release and determination of the resulting inundated area are discussed in the following paragraphs.

9.9.2 Failure Scenarios

Dam failures can occur in a number of ways, but most result from: (1) overtopping of the dam due to inadequate spillway capacity, (2) failure of the dam structure as the result of an earthquake, or (3) the flow of water through the embankment leading to development of a breach in the embankment (i.e., “piping”).

The first scenario is the most common, as there are many existing dams in the U.S. that do not have a spillway capacity adequate to handle the most extreme rainfall events. Consequently, states are requiring upgrades at these facilities to meet current requirements. These upgrades typically include such remedial measures as raising the dam crest and increasing spillway capacity. In some cases, measures such as armoring the dam with roller-compacted concrete are employed to allow overtopping to occur while the structure remains intact.

Piping failures result from pathways through a dam embankment where seepage gradually increases transport of fine materials until a point is reached where pore pressures are high over a relatively large area and a breach initiates. Spillway/decant pipes extending through a dam embankment are vulnerable locations for this phenomenon to occur, and care must be taken to minimize the potential for seepage flow along these structures.

A major earthquake can result in an increase in soil pore pressure and sliding failure, usually in the upstream portion of the embankment. The crest of the dam drops during the embankment failure, resulting in a breach. Upgrades to prevent this type of failure typically require major and very costly repairs.

Catastrophic dam failures can also result from causes such as landslides, foundation failure, sabotage or damage to operational equipment.

While some technical studies of breach formation have been carried out (Wahl, 1998), the composition of earth embankment dams is highly variable and there is little actual data available for calibrating model results. Thus, breach development has not been accurately related to a specific dam failure scenario.

At the present time, modeling of potential dam failures usually involves two basic scenarios. The first is overtopping of the dam during high flow (Inflow Design Flood) conditions and the second is catastrophic failure of the dam on a day with normal (sunny day or fair weather) flow conditions. These two scenarios provide a reasonable representation of the range of conditions resulting from the possible failure modes.

Coal refuse disposal facility embankments are developed in stages over several years, ultimately resulting in a massive structure sometimes 1,000 feet or more in width and several hundred feet high. Dam breach analyses should consider intermediate stages (which may have a narrower embankment cross section) as well as the final facility configuration, because the failure of an intermediate stage could occur more rapidly and could result in a greater breach flow and thus more significant downstream inundation than breach of the facility in its final configuration.

An important consideration for coal refuse slurry impoundments is the volume of fine coal refuse that could be released during a hypothetical dam failure. Based upon data from a wide range of tailings dam failures, Vick (2000) estimates that, while on average about 25 percent of the impounded contents are released, the release of impounded contents can approach 100 percent. Rico et al. (2008) evaluated historical records of tailings dam failures and releases to identify factors affecting the runout distance and peak discharge, finding that, on average, one-third of the tailings and water (to the post-failure level) was released. Overtopping from floods appears to mobilize and release more tailings.

While considerable uncertainty exists, the above estimate appears to be consistent with observations reported by Owens (2008) for incidents at coal refuse impoundments. The settled fine coal refuse frequently remains in a soft or loose condition until sufficiently consolidated and thus may be in a flowable state. Michael et al. (2005) performed a literature review to evaluate the ability of fine coal refuse to flow. While no specific test data are available for fine coal refuse, evaluation of other tailings materials led them to conclude that saturated refuse may be susceptible to high pore pressure and static liquefaction when containment is breached. In order to conservatively estimate the amount of fine coal refuse that could be released from a dam breach, some states prescribe consideration of all water, slurry and settled fine coal refuse contained within the impoundment from the breach invert to the crest, when computing downstream flows. Adoption of a reduced volume of settled fine coal refuse will generally require site-specific information concerning the consistency and resistance to flow of the material.

In addition to failure of the dam, breakthrough of the impoundment into an underground mine may represent another type of release pathway. This pathway could lead to significant discharges in streams in other watersheds, depending on the alignment and extent of extraction of the underground mine.

TABLE 9.20 INUNDATION ANALYSIS SOFTWARE

Program	Method of Analysis
HEC-1	Muskingum-Cunge Modified Puls
HEC-RAS	One-Dimensional Unsteady State Flow
SMPDBK	Approximate Method
DAMBRK	One-Dimensional Unsteady State Flow
FLDWAV	One-Dimensional Unsteady State Flow

9.9.3 Analytical Methods

The failure of a dam results in a condition referred to as rapidly varied unsteady flow. This is a very complex flow condition that can be modeled with computer software. However, programs that provide the most sophisticated modeling of rapidly varied unsteady flow can be difficult to use. Thus, the popular programs used for dam breach analysis represent simplifications to some degree of rapidly varied unsteady flow analysis. A listing of software frequently used for dam breach analysis and the analytical approach employed is provided in Table 9.20.

HEC-1 is frequently used for dam breach analysis for mine impoundments, and the other software listed in the table are less commonly employed. In terms of sophistication, HEC-RAS, DAMBRK and FLDWAV are the most technically advanced and should provide more accurate results than HEC-1. HEC-1 and HEC-RAS were developed by the USACE Hydrologic Engineering Center, while the latter three programs in the preceding table are National Weather Service programs.

HEC-RAS (River Analysis System) is a second generation program from the USACE Hydrologic Engineering Center and is the successor program to HEC-2. It was first released in 1995 and gained unsteady flow analysis capabilities in 2000. The unsteady flow portion of the program was adapted from UNET. The program has the capability of modeling mixed flow regimes and can account for channel constrictions and off-channel storage.

DAMBRK was developed by Fread (1988) for modeling unsteady flow associated with dam breaches. FLDWAV, which was introduced in 1998, is the successor to DAMBRK and DWOPER and provides advanced capabilities over both programs. SMPDBK is based upon an approximate methodology, and under some circumstances can provide results within 10 percent of the results provided by DAMBRK.

In terms of modeling accuracy, both HEC-1 and SMPDBK have clear limitations. The accuracy of these programs diminishes in situations involving channel constrictions and resulting backwater. The final version of HEC-1 was released in 1998, and the program has been replaced by HEC-HMS, which offers one-dimensional kinematic wave routing for dam breach analyses. This methodology does not account for inertial and pressure forces, and the energy slope is assumed to be equal to the channel slope. Thus, HEC-HMS is best suited to relatively steep channels and urban areas where natural channels have been modified to regular shapes and constant slopes.

FLDWAV is the most sophisticated program currently (2009) available. It utilizes finite-difference approximations to solve the Saint-Venant equations for one-dimensional unsteady flow and can account for natural features such as off-channel storage and channel constrictions. The program is capable of handling a wide range of channel configurations and data input. However, FLDWAV requires some calibration for optimum accuracy. Other programs such as HEC-RAS and predeces-

sors to both HEC-RAS and FLDWAV are capable of providing adequate results depending upon the nature of the breach, outflow hydrograph and downstream channel configuration.

GIS-based software is gaining in popularity in hydrology and hydraulics applications and has been used in combination with unsteady flow analysis software. WMS (a GIS-based hydrologic model) can be used in conjunction with software such as HEC-RAS and SMPDBK. BREACH and FLDWAV have reportedly been used in combination with GIS-based software to assess dam breaches and inundation mapping. Also ESRI, the developer of ArcGIS, and the USACE Hydrologic Engineering Center have worked together to create HEC-GeoRAS, which allows the results of flood routing analyses to be displayed in a GIS environment. Eventually, GIS-based models, either packaged with or used in combination with sophisticated unsteady flow analysis software, will be the accepted approach for dam breach modeling and presentation of results.

Another issue related to software selection is the available topographic data for the analyses, the level of accuracy required, and the user's familiarity with the software. It is common to obtain topographic and cross-section information from USGS quadrangle maps with some field observation and verification. Generally, a high degree of accuracy is not required for defining inundation limits and for identifying potential evacuation requirements, particularly in remote areas. Thus selection of less sophisticated software for EAP development is quite often adequate. However, use of a breach analysis to support a hazard-potential classification other than high hazard potential may require careful evaluation of the assumptions incorporated into the software. As discussed previously, communication should be maintained with dam safety regulators (both state and federal) relative to software usage.

9.9.4 Input Data

9.9.4.1 Breach Parameters

A breach in an earth embankment dam is generally assumed to be trapezoidal in shape and can be defined by depth, width, side slopes and development time. A comprehensive study of breach development was carried out by Wahl (1998) for earth dams. While an accurate depiction of breach development is desirable, the process is highly variable and difficult to predict, and conservative assumptions based on published guidelines are normally accepted. Discussions with agency personnel should prove valuable in this regard. In situations where the downstream channel is relatively broad in comparison to the volume of the release, the use of conservative breach development geometry and time may not matter, as discussed in [Section 9.9.6](#). Some state agencies require that the release include the entire volume of tailings. When a site-specific evaluation is performed, it should be compared with the following guidance for estimating the minimum volume of release for fine refuse:

- An equal volume of fine refuse (as stored) and flood water
- One-third of the fine refuse stored

The volume of fine refuse released can then be used with other site-specific factors to estimate the breach depth and configuration and duration of outflow. Some guidelines for determination of breach parameters (FERC, 1993) are presented in [Figure 9.47](#). Physical limitations such as the width and depth of the valley should be considered when applying the guidelines.

Programs used for routing dam breach flows (HEC-1 or HEC-RAS, DAMBRK, FLDWAV, etc.) typically have input parameters for defining the breach geometry and development time. These programs expand the size of the breach from zero to the full dimensions in the specified development time using an internal algorithm.

One software program for breach development is the National Weather Service (NWS) program BREACH, which was developed by Fread (1988). This program is a physically-based breach simula-

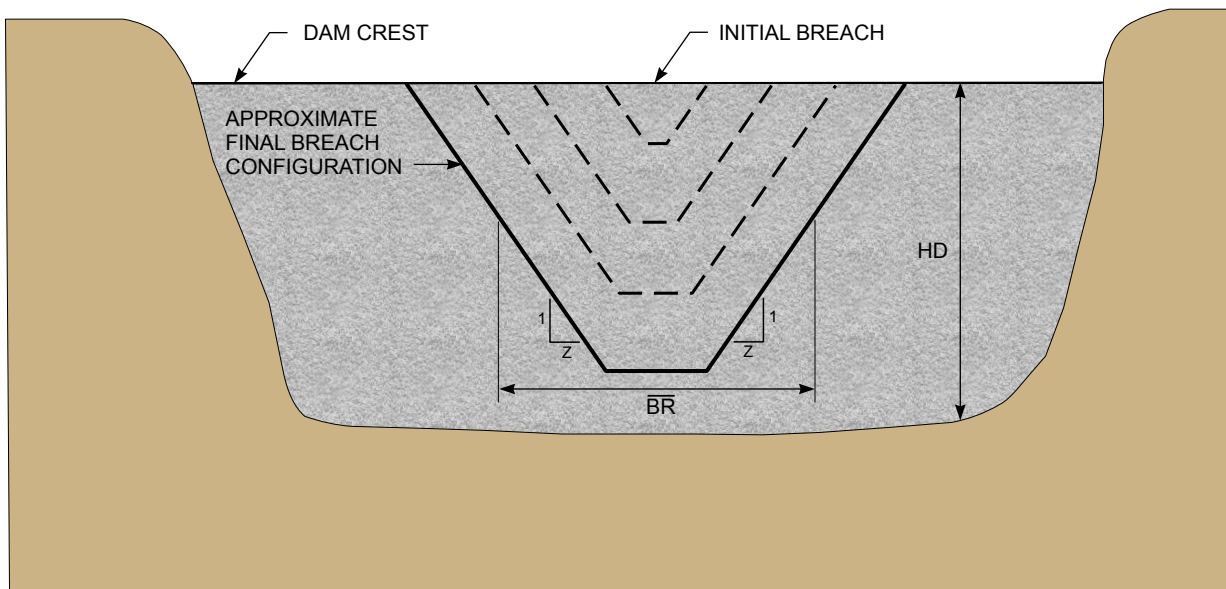

FOR ENGINEERED EARTHEN DAMS:

$$HD \leq \overline{BR} \leq 5HD$$

$$0.25 \leq Z \leq 1$$

$$0.1 \leq TFH \leq 1.0 \text{ HOUR}$$

FOR NON-ENGINEERED DAMS OF SLAG, REFUSE MATERIALS:

$$\overline{BR} \geq 0.8 \times \text{CREST LENGTH}$$

$$1 \leq Z \leq 2$$

$$0.1 \leq TFH \leq 0.3 \text{ HOUR}$$

WHERE:

\overline{BR} = AVERAGE BREACH WIDTH

HD = HEIGHT OF DAM

Z = HORIZONTAL COMPONENT OF BREACH SIDE SLOPE

TFH = TIME TO FULLY FORM BREACH

(ADAPTED FROM FERC, 1993)

FIGURE 9.47 BREACH PARAMETERS

tion model, but concerns regarding the model have been raised (Wahl, 1998). The hydrograph calculated by BREACH can be used as the dam breach hydrograph by unsteady flow modeling software. Coal refuse impoundments can include massive embankment stages, such that an intermediate embankment stage configuration may represent a more critical breach geometry and time of failure than the final development configuration. Modeling a partial failure of a coal refuse dam using programs such as SMPDBK may result in a peak outflow discharge that is higher than that from breaching the full height of the dam all the way down to the natural valley bottom. Since slurry impoundments, especially upstream-construction dams, often contain a considerable amount of consolidated slurry and have a relatively small water storage volume as compared to conventional water supply, flood control, or multipurpose dams, this may be more representative of the actual consequences of a slurry dam failure. However, some state regulatory agencies require that all of the saturated fine coal

refuse be treated as flowable and that a breach analysis be based upon a breach extending the full height of the embankment (from the final crest to the foundation).

9.9.4.2 Initial Conditions

Generally, the flow into an impoundment and in the channel downstream from the dam is assumed to be constant and equal to the design storm condition immediately prior to dam breach. Frequently the design storm is the PMF, which represents an extreme upper-bound inflow to the impoundment that will only rarely be approached (Section 9.5). Sometimes the design storm will be less than the PMF, but as long as it exceeds the spillway capacity, the dam could be overtopped and catastrophic failure could occur. The impoundment water surface elevation used in the dam breach model should be the minimum required for breach initiation.

For a sunny day breach, normal steady-state stream flows into the impoundment and in the downstream channel should be assumed. These can usually be obtained from published stream gage data or on-site records. Estimates of flow can be developed based upon channel dimensions and slope, estimated roughness and calculated normal flow velocity in the absence of recorded flow data. The water surface in the impoundment is typically assumed at normal pool elevation for a sunny day breach.

9.9.4.3 Flow Channel Geometry and Roughness

All dam-breach flow models require a description of the downstream channel and floodplain geometry (i.e., cross sections) and roughness. Roughness is usually defined in terms of Manning's n , and values for Manning's n are available in the literature for a wide range of conditions (Chow, 1959). Typically, out-of-channel flow encounters substantial resistance from brush, trees, debris and even dwellings, so that the Manning's n for the floodplain is much higher than for normal channel (USGS, 1989).

A key factor that can cause elevated flood levels is the presence of constrictions such as bridge and railroad embankment crossings or severe natural channel narrowings in the reach downstream from the dam. These can cause temporary backwater elevation and localized increased flooding. Additional cross section data (i.e., closer cross section spacing) may be needed in these constricted areas.

The presence of an existing downstream impoundment or impoundments may result in the need to extend the flow model farther downstream.

Typically for a dam breach analysis under design storm conditions, the area of interest along the channel terminates when the flow reaches a certain increment above the flow elevation without the dam breach (typically 1 to 2 feet). For a sunny day breach, the area of interest along the channel normally terminates when the flow returns from the floodplain to the natural channel or to a level associated with a specified recurrence interval flood. Thus, downstream channel data should extend past the points where these control points are anticipated to occur.

In addition to natural channels, another pathway for an impoundment breach is via breakthrough to an underground mine, with discharge through the mine and out of associated mine openings. This can lead to potential inundation in watersheds other than that in which the impoundment is located, depending on the size and extent of the mine.

9.9.5 Results of Analysis/Inundation Mapping

The output from flow model software will be water surface elevations and flow velocity at each channel cross section in the model. Additionally, the model software can provide the time of

arrival of the flood wave from the breach, which is useful for the EAP development. The maximum water surface elevation at each cross section following the dam breach will define the extent of inundation. It is important to note that the maximum inundation elevation for an unsteady flow analysis does not occur at the same time at each cross section. Therefore care must be taken to record the highest level at each cross section and to use these values in determining the limits of inundation.

The flow velocity is also computed for each channel cross section, which may be helpful in assessing the potential threat to occupied structures or roadway travelers, as discussed in Section 9.5.1.3.2. It is important to note that while the average velocity in the floodplain may be provided as part of the model output, it is advisable to perform an independent computation of the flood velocity for the structure location, considering the maximum water surface elevation and energy grade line.

As discussed in the previous section, the inundation map should extend downstream from the dam to the farther of the termination points associated with a breach occurring under design storm and sunny day conditions.

Plotting the extent of inundation can be tedious if done manually because the water surface elevation is falling relative to a fixed datum and thus the extent of inundation will not match or be parallel to any ground surface elevation contours. GIS-based software can provide plots of the inundation limits as part of the normal output and thus eliminate the need for manual plotting.

9.9.6 Sensitivity Analyses

It may be useful to perform multiple dam breach analyses with variations in selected input data to evaluate the effect of the variation on the analysis results. For dam-breach analyses, the parameters associated with the breach development (i.e., dimensions and development time) are likely to be the most controversial. Since a breach analysis can directly affect the safety of downstream residents, it is prudent that conservative dam-breach analyses be performed. If, for example, substantially reducing the breach development time does not significantly alter the results in terms of inundation levels and extent of inundation, then conservative breach assumptions can be used in the analysis and may expedite regulatory review of the EAP.

9.9.7 Hazard Classification

Most commonly, a dam-breach analysis is performed as part of preparing an EAP for a dam that has already been classified as having high or significant hazard potential. Another purpose for a dam-breach analysis could be to establish the hazard classification in the first place. In this event, the FEMA (2004a) or applicable state criteria should be followed. The FEMA criteria are listed in Table 9.21.

TABLE 9.21 HAZARD POTENTIAL CLASSIFICATIONS

Hazard-Potential Classification	Loss of Human Life	Economic, Environmental, Lifeline Losses
Low	None expected	Low and generally limited to owner
Significant	None expected	Yes
High	Probable – One or more	Yes

(FEMA, 2004a)

If populated areas are impacted, particularly areas located close to the dam, a high-hazard-potential classification should normally be assigned. As discussed in [Section 9.5.1.3.2](#), other criteria, such as depth or velocity of flow, may also be considered by designers and accepted by regulatory agencies for determining the potential significance of the inundation level and to assign the associated hazard classification. Other classifications should be consistent with [Table 9.21](#) and the limits of inundation.

Chapter 10

ENVIRONMENTAL CONSIDERATIONS

Environmental considerations for coal refuse disposal facilities generally involve potential impacts to streams and wetlands, air quality, and water quality. Impacts to streams and wetlands originate with facility siting. Air quality issues arise from dust and burning associated with coal refuse embankments. Water quality issues are typically related to the generation of acid leachates by coal refuse or to erosion and sedimentation at refuse surfaces or disturbed areas under development. Liner systems have been used to provide protection of groundwater, and reclamation of coal refuse disposal embankments can mitigate air and water impacts.

Federal and state air and water quality regulatory programs govern site discharges and must be considered in coal refuse disposal facility design. Thus, review of applicable regulatory programs and permit requirements should precede the design of coal refuse disposal facilities. Similarly, liner systems are generally regulated by states.

In light of the above, this chapter provides a general discussion of environmental issues associated with coal refuse disposal facility design, construction, and reclamation.

10.1 STREAMS AND WETLANDS

Coal refuse disposal facilities often impact streams and wetlands regulated by the Clean Water Act (CWA). This legislation was originally enacted in 1972 and was subsequently amended in 1977. When a planned coal refuse disposal facility will impact streams and wetlands, several types of permits and certifications may be required by CWA regulations. Although the U.S. Environmental Protection Agency (USEPA or EPA) has regulatory authority over the CWA, the permits and certifications may be administered and enforced by other federal, as well as state or local agencies. These agencies may include the USEPA, the U.S. Army Corps of Engineers (USACE), the U.S. Fish and Wildlife Service and state Departments of Environmental Protection (state DEPs).

The CWA was enacted with the intent of restoring and maintaining the chemical, physical and biological integrity of the waters of the United States. The term “waters of the United States” includes the following:

1. All waters which are currently used, or were used in the past, or may be susceptible to use in interstate or foreign commerce, including all waters which are subject to the ebb and flow of the tide;

2. All interstate waters including interstate wetlands;
3. All other waters such as intrastate lakes, rivers, streams (including intermittent streams), mudflats, sandflats, wetlands, sloughs, prairie potholes, wet meadows, playa lakes, or natural ponds, the use, degradation or destruction of which could affect interstate or foreign commerce including any such waters:
 - i. Which are or could be used by interstate or foreign travelers for recreational or other purposes; or
 - ii. From which fish or shellfish are or could be taken and sold in interstate or foreign commerce; or
 - iii. Which are used or could be used for industrial purpose by industries in interstate commerce;
4. All impoundments of waters otherwise defined as waters of the United States under the definition;
5. Tributaries of waters identified in paragraphs 1-4 of this section;
6. The territorial seas;
7. Wetlands adjacent to waters (other than waters that are themselves wetlands) identified in paragraphs (a) (1)-(6) of this section.

Waste treatment systems, including treatment ponds or lagoons designed to meet the requirements of CWA (other than cooling ponds as defined in 40 CFR § 123.11(m) which also meet the criteria of this definition) are not waters of the United States.

8. Waters of the United States do not include prior converted cropland. Notwithstanding the determination of an area's status as prior converted cropland by any other federal agency, for the purposes of the Clean Water Act, the final authority regarding Clean Water Act jurisdiction remains with the EPA.

Coal refuse disposal facilities that impact waters of the United States must be permitted and certified under the federal regulations outlined in the CWA. The various sections of the CWA regulate the activities described below:

- **Section 401 – Water Quality Certification**

This section of the CWA requires that any applicant for a federal permit to construct and operate a coal refuse disposal facility that may result in the discharge of any pollutant must obtain certifications for those activities from the state in which the discharge originates. This certification is referred to as the Water Quality Certification for the project.

- **Section 402 – NPDES Regulations**

The 1972 amendments to the CWA established the National Pollutant Discharge Elimination System (NPDES) permit program to control discharges of pollutants from point sources. The NPDES permit may be administered and enforced by a local USEPA branch or state DEPs. Some states have additional requirements for storm-water discharges that may impact planned coal refuse disposal facilities and are not covered by the CWA.

- **Section 404 – Dredge/Fill Permitting**

This section of the CWA established a permit program to regulate the discharge of dredged or fill material into waters of the United States. This permit program is administered by the USACE under a memorandum of agreement between the

Department of the Army and the USEPA. Under Section 404 of the CWA an individual or general permit may be needed based on the proposed activities.

In addition to the Clean Water Act, other statutes and regulations such as the Surface Mining and Reclamation Act (SMCRA) of 1977 and the Safe Water Drinking Act (1974) may be applicable to coal refuse disposal facilities with respect to streams and wetlands. These regulations may result in additional permitting not covered by the CWA. The Office of Surface Mining (OSM), U.S. Department of the Interior, is responsible for the national program to regulate the surface effects of coal mining activities, although each state may take on primary responsibility if the state's regulatory program is approved by the OSM.

Consideration should be given early in the design process to the permits and certifications required for coal refuse disposal facilities as they relate to streams and wetlands. The time involved in the permitting process is typically lengthy and must be accounted for in coal refuse disposal facility design. Agencies such as the USEPA, USACE, U.S. Fish and Wildlife Service, state DEP, and local municipalities should be contacted prior to permit preparation to determine what permits and certifications will be required and which agencies will administer and enforce them. Once the required permits are determined, it may be beneficial to hold a pre-submittal meeting with the appropriate agencies. After the meeting, the permit applications should be submitted in a timely manner, allowing for responses to permit application comments. Some states have moved to a combined application process, although generally permit applications are submitted separately and at various times during the design process.

10.2 AIR QUALITY

Coal refuse disposal can create two types of air quality problems: (1) fugitive dust and particulate matter and (2) noxious gases originating from burning refuse embankments. Fugitive dust becomes airborne due to wind and coal refuse handling and placement. Sources may include: emissions from haul roads; wind erosion from exposed surfaces, storage piles and spoil piles; reclamation operations; and other material or earth disturbance activities. Fugitive dust can be ingested by humans and animals and can also be harmful to vegetation. High concentrations of sulfur dioxide associated with the combustion of coal refuse are toxic to nearby vegetation. Also, sulfur dioxide, organics (polynuclear aromatic hydrocarbons such as benzo(a)pyrene), and metals (mercury and arsenic) are harmful if inhaled in significant volumes by humans.

Dust is regulated as an air emission by state DEPs or, if no approved state program exists, by the USEPA. If amendments are being considered or co-disposal with combustion waste is planned, dust control requirements can take on greater significance than with normal construction. If accidental combustion occurs at coal refuse disposal facilities, air emissions can become a significant health and safety concern, and methods to address burning may need to be developed and implemented as part of a remedial action.

The following sections discuss measures for controlling dust and for reducing the potential for combustion or controlling burning should it occur.

10.2.1 Dust Control

The transportation and placement of coal refuse can create a considerable amount of fine particulate matter that is susceptible to wind erosion. Coal refuse is compacted and crushed by machinery during placement and further deteriorates through physical weathering and chemical decomposition. When refuse-related dust problems occur, they can be mitigated by stabilizing the surface layer of the refuse. This can be accomplished by applying water or a dust suppressant solution over disturbed areas, establishing windbreaks of trees or hedgerows that alter both the direction and the

velocity of wind over the refuse material, or performing reclamation by covering and vegetating the disturbed surface (Coalgate et al., 1973).

In situations where a relatively quick dust control procedure is needed or where vegetation is for some reason impractical, stabilization has been achieved using various commercially available chemical agents. Chemical seals have been accomplished through application of: (1) a lime chip-sodium or potassium silicate topdressing over the refuse material, (2) a resinous or bituminous-base adhesive, (3) calcium, ammonium and sodium lignin sulfonates and bark extracts, (4) resin and wax emulsions or neoprene, and (5) elastomeric organic polymers (Coalgate et al., 1973; Dean and Havens, 1972; and Eigenbrod, 1971). When applying such products to areas such as haul roads that will experience truck or heavy-equipment traffic, the effect on traction should be considered.

Erosion control mats that have plant seeds incorporated within the binding material have been successfully used to vegetate disturbed construction areas and to control dust.

10.2.2 Combustion Control

Current practices in the mining industry have virtually eliminated coal refuse fires. The reason is two-fold. First, the amount of coal in coal refuse has been greatly reduced because of more efficient removal of coal during mining and processing. Secondly, current embankment construction practices involve thorough compaction of refuse material, thus restricting the flow of air and moisture that can create a favorable environment for heat generation. Thus, the discussion provided herein is mainly applicable to older existing embankments.

Components of air emissions from burning coal refuse may include carbon, nitrogen, sulfur compounds and metals such as arsenic and mercury. These emissions can impact human health and the environment. Air emissions along with elevated temperatures can degrade existing vegetation and make establishment of new vegetation impossible.

Coal refuse embankment fires have been caused by spontaneous combustion and in some instances from careless burning of trash or other debris. Coal refuse fires have also been intentionally started to obtain "red dog" material for use as a road construction base or have been accidentally ignited by natural causes such as lightning or forest fires. Historically, the most common cause of coal refuse fires has been spontaneous combustion resulting from the self-heating tendencies of coal. The potential for spontaneous combustion is greatly increased if oxidizing materials such as pyrites are present and if these oxidizing materials are wet (Coalgate et al., 1973; Mihok and Chamberlain, 1968; Nicholas and Hutnik, 1971).

Self-heating of coal refuse generally occurs due to exposure of organic and carbonaceous materials to moisture and oxygen, creating reactions that generate heat. When the generation rate of heat exceeds the rate of heat loss, temperatures within a refuse pile can reach the ignition temperature of the remaining coal and carbonaceous materials. The generation rate of heat is a function of the concentration of reactants (thermophillic bacteria, carbon and oxygen), surface area of the pile, particle sizes of the coal refuse and ambient air temperature (Kim and Chaiken, 1990). When coal refuse is exposed to water and oxygen, heat can be generated from the respiration of bacteria up to a temperature of about 120 to 170 degrees Fahrenheit ($^{\circ}$ F), when the bacteria die. Beyond this temperature range, oxidation of carbon and carbonaceous materials has to occur if the ignition temperature of coal (in the approximate range of 620 to 788 $^{\circ}$ F for bituminous coal and 842 to 950 $^{\circ}$ F for anthracite coal) is to be reached (Maneval, 1969).

In addition to creating air quality problems, burning refuse embankments can also create potentially dangerous working situations. The most common of these is the creation of burned-out voids or pockets within the interior of the refuse embankment that can lead to surface cave-ins and/or hazardous slides. Attempts to extinguish smoldering refuse facilities with water can cause violent explosions if

these burned-out voids become filled with pressurized steam. Explosions can also occur in the vicinity of burning material as a result of airborne coal dust produced during the handling of coal refuse.

Under current disposal conditions, the likelihood of coal refuse igniting is extremely low because of low pyrite and/or coal content. When coal refuse is spread and compacted in lifts in stable embankments, fires rarely occur. Other standard construction practices that should be followed for mitigating combustion potential include:

- Prior to placement of any coal refuse material at a new site, all vegetation and other combustible materials should be removed from the area where refuse will be placed.
- All refuse materials with high pyritic and coal content should be compacted as the facility is constructed, and all large rocks should be crushed or removed to a separate location to prevent the creation of air pockets in the embankment (Coalgate et al., 1973).
- If present, waste materials with high pyritic and coal content should be allowed to weather separately prior to their placement at a refuse facility in order to lessen the chance of a thermal buildup due to oxidation.
- If oxidation is a potential problem, coal refuse facilities should be designed and constructed in a manner that minimizes the amount of exposed surface area in order to decrease the air infiltration (Coalgate et al., 1973).

Typically, detection of burning is based upon on-site visual observation (i.e., noting the presence or absence of smoke and/or sulfur dioxide fumes). However, there is no inexpensive means of detecting overheated refuse materials below the embankment surface prior to their combustion. Methods that have been used to detect combustion of conditions leading to combustion include:

- Gas Emission Monitoring – Carbon monoxide (CO) is a by-product of coal refuse oxidation and can be detected very early in the oxidation process. Surface monitoring of CO emissions can thus indicate the potential for spontaneous combustion. Hydrogen sulfide (H₂S) is also a by-product of coal oxidation. Concentrations of this noxious gas will be present prior to combustion and can also be detected through monitoring (Chamberlain and Hall, 1973; Chamberlain et al., 1970; Guney, 1968).
- Direct Thermal Monitoring – The internal temperatures of refuse embankments can be monitored by inserting temperature probes into driven pipes or drilled holes. The temperature buildup associated with oxidizing refuse material can thus be profiled.
- Remote Sensing – Thermal and optical images from an airborne platform can be used to identify the location, depth, size and propagation of hot spots and fires (Zhang et al., 2004). Landsat TM imagery and airborne thermal scanner data have been employed in remote sensing studies for measuring ground surface temperatures. The surface temperature data can then be used for estimating the extent and depth of coal fires using thermodynamic models.
- Electrical Resistivity Geophysical Survey – Some researchers have employed surface DC electrical resistivity for distinguishing burnt sedimentary rock with relatively high resistivity from non-impacted sedimentary rock. The burnt rock has a higher porosity, more cracks and lower water content, which allows it to be distinguished from the non-impacted rock.

10.2.3 Refuse Fire Extinguishment

Extinguishing coal refuse fires is normally not a problem confronting engineers and designers of new coal refuse facilities. However, when an existing facility is being modified or added to, fire abatement

can be an important part of the engineering and design process. Fire extinguishment can also be a critical consideration when a refuse embankment is being prepared for abandonment.

Studies have determined that refuse embankment fires generally burn in a temperature range between 600° and 2000° F. It has also been found that once refuse materials have reached a temperature of approximately 200° F, either through spontaneous heat buildup or through heat transfer from adjacent areas, they will eventually self-ignite given favorable conditions such as an abundant supply of air and moisture (Magnuson and Baker, 1974).

Since the reactions that create heat are inherently variable, no single safe temperature has been identified below which heat buildup and refuse ignition will not occur. Ignition temperatures vary with each embankment and with location within the embankment and are largely a function of available air and the site-specific characteristics of the coal refuse. It is therefore not enough to extinguish the burning portion of a refuse embankment. Steps must also be taken to: (1) lower the temperature of the refuse below the point of re-ignition and (2) eliminate embankment conditions that could lead to temperature buildup and future re-ignition.

Temperatures in coal refuse embankments that are sufficient for combustion have been measured at depths of 100 feet or more. However, at that depth the amount of available oxygen is minimal and ignition will not occur. If, however, "hot spots" are exposed through the excavation of overburden or through some other embankment modification, the additional available oxygen may cause these areas to ignite. Critical extinguishment depths are therefore related to site-specific conditions and may be affected by future actions that may alter these conditions.

As indicated previously, the most critical concerns facing those attempting to extinguish a coal refuse fire are the unique dangers involved in using water and in excavating materials in ways that may cause airborne dust. Explosions that can result from such practices can hurl hot debris over nearby areas and can lead to failure of the refuse embankment. Similarly dangerous are smoldering internal voids created when a refuse embankment burns. These areas of potential cave-in can be extremely dangerous to workers and fire fighters alike. Carbon monoxide poisoning is also a danger.

Despite these potential dangers, a number of fire-fighting techniques have proven successful in certain situations. For purposes of discussion these techniques can be grouped into three general categories: (1) physical removal of the burning refuse, (2) quenching and/or sealing by surface treatment, and (3) quenching and/or sealing by injection into the burning refuse. These methods are briefly discussed in the following paragraphs and are also summarized in [Table 10.1](#).

10.2.3.1 Excavation and Removal

Excavation and removal has historically been the predominant method for extinguishing refuse embankment fires (Kim and Chaiken, 1993). This approach has several variations, each generally involving the removal of burning materials from the refuse embankment. The removed materials may be extinguished by quenching, cooling, and suffocation, or they may simply be allowed to burn out. This method can be effectively used when the burning areas are relatively small and accessible and when removal activities do not adversely affect embankment stability. Extreme care must be taken to minimize airborne coal dust when handling burning refuse materials. This dust can ignite and cause violent explosions. Also, any time that equipment is working over burned-out areas, there is a danger that large voids created by the fire will collapse under the weight of the equipment. Variations of the excavation and removal approach include:

- Excavation – Small and readily-accessible burning areas can be extinguished by removing the burning refuse material from the embankment using construction equipment. The removed material can then be extinguished through quenching, or

TABLE 10.1 FIRE EXTINGUISHMENT TECHNIQUES

	Method	Brief Description	Limitations
Physical Removal	Excavation	Burning refuse excavated from embankment; extinguished or allowed to burn itself out; facility regraded and sealed	<ul style="list-style-type: none"> • Dust and noxious fumes • Access to burning material • Possible cave-ins • Weakens refuse facility
	Water cannons	Water cannons used to dislodge and quench burning refuse; quenched material replaced and recompact on refuse facility	<ul style="list-style-type: none"> • Source of quenching water • Weakens refuse facility • Potential for dust explosion
	Isolation	Burning zone isolated by excavating trenches; burning zone quenched or buried with inert sealing material; trenches refilled with inert material	<ul style="list-style-type: none"> • Access to burning material
	Controlled burnout	Burning refuse is allowed to burn under monitored and controlled conditions	<ul style="list-style-type: none"> • Access to burning material • Duration is uncertain • Weakens refuse facility
Surface Treatment	Blanketing or sealing	Entire burning embankment covered with mantle of clay or soil; compacted; burning is smothered	<ul style="list-style-type: none"> • Limited to small facilities • Maintaining seal's integrity • Possible cave-ins • Source of clay or soil
	Foam covering	Entire refuse facility is sealed with a commercial foam blanket; oxygen denied the refuse; burning is extinguished	<ul style="list-style-type: none"> • Facility size • Maintaining a seal • Can't use where burning is near surface
	Rice paddy technique	Suited for flat refuse areas; dikes constructed around perimeter and area flooded; water percolates into burning zone; fire quenched.	<ul style="list-style-type: none"> • Supply of water • Possible cave-ins • Slow • Stability
	Water sprinklers	Burning refuse facilities are "wet-down" or saturated by a system of sprinklers until burning is extinguished	<ul style="list-style-type: none"> • Water source • Saturation weakens structure • Reignition possible
Internal Treatment	Multiple well-point system	Horizontal insertion of perforated metal piping near base of embankment; water injected; pipes removed and reinserted in higher strata; process repeated for total structure	<ul style="list-style-type: none"> • Source of quenching water • Slow • Weakens refuse facility
	Slurry injection	Vertical or angle holes drilled into burning embankment at various depths; liquid slurry injected into burning voids; steam vent pipes inserted; heat reduction monitored	<ul style="list-style-type: none"> • Slow • Stability

it can be allowed to burn at a safe distance from the refuse embankment. Once the burning material has been removed from the embankment, the excavated portion should be backfilled, regraded, compacted and covered with a sealing material that will limit air flow (Coalgate et al., 1973; Jolley and Russell, 1959). A major drawback to this approach is that machinery operators may be exposed to large doses of noxious and toxic gases that are dangerous if exposure is prolonged. Health and safety monitoring, air monitoring and use of personal protective equipment are required for this activity.

- Water cannons – Water cannons similar to those used by fire departments have been used to dislodge and quench burning refuse materials when they are near embank-

ment surfaces. Removal of the quenched material can be accomplished by: (1) hydraulic sluicing using a water cannon, (2) excavation by dragline, and (3) loading on trucks for dumping elsewhere. For all three alternatives the extinguished material should be re-spread and compacted in accordance with facility plans and specifications. The use of this technique is contingent upon the availability of water and the stability of the embankment during hydraulic excavation (McNay, 1971).

- **Isolation** – Burning materials can be isolated from the remainder of the refuse facility by cutting trenches around them. To eliminate heat transfer, such excavations should be at least 6 feet wide and should extend into the embankment foundation. Once the burning material is isolated, it can be extinguished with water, by applying a sealant, or by burying under a blanket of non-combustible material. The exposed trench faces should be sealed with clay or fine-grained soil to restrict air flow, or the trenches should be backfilled with non-combustible material such as soil. To prevent heat transfer from the burning portion of the embankment to non-burning areas, sand or other heat-conducting material should not be used as backfill (Coalgate et al., 1973; Jolley and Russell, 1959).

To mitigate the potential for explosions, excavations into refuse materials that are known or suspected to be burning must be performed with extreme care if hot or burning materials will be exposed to airborne coal dust and/or moisture. Through monitoring, areas of high material temperature can be mapped (if boreholes are used, they should be sealed to prevent airflow). Excavation should be performed in stages and monitored with the intent of avoiding opening up burning areas to moisture and coal dust in confined spaces. Work should proceed downwind (from upwind areas) using equipment that can operate from above and away from burning areas. Upon completion of the excavation, backfill materials should be placed in lifts and compacted, which will minimize the potential for rekindling.

10.2.3.2 Surface Treatment

The methods described in this section require that the embankment be relatively small and have accessible slope faces. Basically, surface treatment involves sealing of the entire surface of an embankment to restrict air flow to the fire. The primary problem with surface seals is maintaining them until sufficient cooling has occurred to prevent re-ignition. This maintenance period can exceed 20 years (Kim and Kociban, 1994), which is greater than the effective life of many types of surface seals. Common surface treatment methods are described in the following:

- **Blanketing or sealing** – In some instances, it may be practical to extinguish burning refuse by blanketing the entire embankment with about 2 feet of non-combustible material such as fly ash, clay or other soil. This cover should be compacted as it is applied, thereby smothering the burning refuse. Breaks in the seal can occur through water erosion, heat cracks, cave-in of burned-out voids, or even wind erosion (Coalgate et al., 1973; Jolley and Russell, 1959; McNay, 1971; Myers et al., 1966). In extreme cases, where the need to extinguish an embankment fire exceeds normal economic constraints, commercial foam sprays (e.g., polyurethane) have been applied (Magnuson and Baker, 1974).
- **Rice-paddy technique** – This procedure is only suited for large, stable, flat-topped refuse facilities. Since minimal fumes and dust are created, it is ideal for sites located near residential areas. Dikes are constructed around the top perimeter of the burning refuse facility and at appropriate intermediate locations. Each diked area or pond is then flooded, and the impounded water percolates into the embankment. Draglines can be used periodically to stir the bottoms of the ponds to increase the rate of percolation. The use of this fire-abatement procedure is dependent upon an abundant

supply of water and is further dependent upon the ability of the burning embankment to support earth-moving equipment during dike construction (Coalgate et al., 1973; McNay, 1971). The impact of dike construction and water irrigation on the stability of the coal refuse embankment must be evaluated prior to implementation of this method.

- Water sprinklers – In some instances, water sprinklers have been used to wet down burning embankments and to provide a continuous supply of water over and through the refuse material. The success of this procedure is largely dependent upon the hydraulic conductivity of the embankment, and vertical drilling may be required to increase percolation into the embankment interior. The saturation of an impounding embankment can be dangerous, as its stability may be greatly reduced (Coalgate et al., 1973; Myers et al., 1966).

Surface treatment methods should be implemented sequentially with monitoring of explosion and emission hazards, particularly if concurrent or subsequent excavation activities are planned, as previously discussed.

10.2.3.3 Water and Slurry Injection

This approach involves injection of water or slurry into the burning zones under pressure. The injected material quenches and smothers the burning material. The use of an injection method can offer one or more of the following advantages:

- While usually more expensive on a unit volume basis, injection is well suited to spot treatment of smaller burning areas within a larger embankment in contrast to excavation and removal or surface treatment, which require remedial work over a much larger area.
- Inaccessible areas on steep slopes can be treated. Pipes can be driven with air hammers while other equipment (mixers, pumps, etc.) can be placed at a nearby level location.
- Men and equipment do not have to work directly over burning areas.

There are basically two types of injection methods:

- Multiple well-point system – This procedure entails driving perforated pipes in a single horizontal plane near the toe of the embankment and pumping water into the pipes. The pipes are placed relatively close to each other (approximately 2 feet on center) so that the injected water thoroughly saturates the entire zone. Once the burning is extinguished in that zone, the pipes are withdrawn and then re-inserted a short distance above their previous location. Water is again introduced to extinguish the fire in this new area. This procedure is repeated until all the burning areas within the embankment are extinguished. It should be emphasized that in order to minimize the potential for re-ignition of the refuse material, this procedure should progress from the bottom of an embankment upward. Because the burning portion of the embankment becomes saturated, the use of this method is not recommended if stability is an issue.
- Slurry injection – When slurry is injected into an embankment, voids and air channels are blocked and air access is restricted (McNay, 1971). The slurries most commonly used are suspensions of fly ash, limestone dust, vermiculite, sodium bicarbonate or mine drainage sludge in water. Pipes are typically driven vertically into the burning zone on 10- to 15-foot centers. Slurry is injected under low pres-

sure (usually 10 to 15 psi) to depths of 40 feet or more. When the slurry is no longer accepted, the pipes are raised and injection is resumed. The interior or deepest portion of the burning zone is treated first in order to prevent further penetration of the fire. Injection then progresses toward the surface of the embankment. Because of the danger of explosions, open pipes should be inserted next to the injection holes to vent steam. Use of cryogenic slurry consisting of liquid nitrogen and granular carbon dioxide to enable quick cooling of the burning material has been proposed. Some initial testing demonstrating the ability of this approach to lower temperatures over an extended period was conducted (Kim and Kociban, 1994).

10.3 WATER QUALITY

As indicated previously, coal refuse facilities can substantially degrade the quality of water in nearby drainage courses if they are improperly constructed. In addition to adversely affecting surface-water, drainage from refuse facilities can also affect the groundwater. Although a variety of water quality problems can be created by coal refuse drainage, the most common effects are: (1) increased turbidity and suspended solids and (2) water quality degradation due to acidic leachates (Martin, 1974).

Water pollution problems created by coal refuse can be substantial. Coal refuse leachates can be acidic, can contain elevated concentrations of metals such as iron, aluminum and manganese, and can also be corrosive. When leachates enter a stream, aquatic environments may be greatly altered and desirable organisms may be reduced or eliminated entirely. When refuse leachates percolate into the groundwater, aquifers can be significantly impacted. The following sections provide a discussion of mine refuse water quality issues and various procedures and techniques for controlling and/or mitigating their adverse effects.

10.3.1 Erosion and Sedimentation

Erosion and sedimentation control plans must be submitted to state and local regulatory authorities as part of refuse disposal facility designs. These plans typically include a variety of measures for diverting drainage from disturbed areas, for controlling erosion, and for removing sediment from runoff before release of surface water from the refuse disposal site. As part of these plans, effluent monitoring programs are typically established to verify that erosion and sedimentation control measures are effective.

10.3.1.1 Prevention

When coal refuse and earthen materials are exposed to weathering, erosion and sedimentation can occur. The following practices can be implemented to minimize erosion and sedimentation:

- Stripping of vegetation from a disposal site should be limited to only the area that is needed for construction. Future fill areas should be stripped immediately prior to construction.
- Topsoil that is removed from a construction area and stockpiled for future use should be stored in a manner that minimizes erosion and should be revegetated as soon as possible.
- During the construction process, care should be taken to preserve vegetation on areas surrounding the disturbed construction area.
- Collection ditches and sedimentation ponds should be constructed at the downstream end of the construction site.
- All fill material exposed during construction should be graded in a manner that minimizes the potential for runoff over the downstream face of the embankment. This is particularly important for the crest and downstream face of the refuse embankment.

- Completed embankment surfaces should be reclaimed and vegetated as soon as practical, while accommodating seepage control measures such as extension of underdrains or installation of collection and discharge systems at the embankment toe.

10.3.1.2 CONTROL

Control procedures for reducing the amount of suspended material entering streams are presented in the following subsections.

10.3.1.2.1 SEDIMENTATION PONDS

Sedimentation ponds are structures designed to intercept and retain water-borne sediment and debris. They are primarily intended for use during construction prior to the establishment of effective vegetation on the disturbed area. Sedimentation ponds should be sized and constructed in accordance with criteria prescribed by state mining regulation agencies. These structures normally do not retain water for long periods and are usually maintained with low water surface levels except following rainfall. Engineering design criteria and standards for sedimentation ponds have evolved from requirements for surface mining operations. In most instances, these standards are also applicable to coal refuse (Davis, 1973).

OSM rules for sedimentation ponds under 30 CFR § 816.46 to 49 generally include the following:

- Sedimentation ponds can be used individually or in series.
- They should be located as near as possible to the disturbed area and not in perennial streams.
- They should provide adequate detention time to meet effluent standards and should contain or treat the runoff from the 10-year, 24-hour precipitation event.
- They should provide sediment storage capacity with periodic sediment removal sufficient to maintain adequate volume.
- Ponds with embankments that meet or exceed the impoundment size criteria or other conditions indicated in 30 CFR § 216 (20 acre-feet capacity or 20 feet in height) should have principal and emergency spillways designed to safely pass the runoff from a 100-year precipitation event or larger, depending upon the hazard potential classification. For ponds that do not meet or exceed the impoundment size criteria, the principal and emergency spillways should be designed to safely pass runoff from the 25-year precipitation event or greater, as specified by the state regulatory authority.

State agencies generally provide additional guidance regarding determination of the sediment storage capacity and may require specific design storm parameters or values for sizing the principal and emergency spillways.

In situations where very fine particulate material is suspended in the refuse drainage, the amount of time required for natural settlement or clarification in a settling basin can be long. If the drainage is carrying a significant volume of suspended solids, clarification can be accelerated through use of chemical flocculants. This practice may also be considered when the capacity of a sedimentation pond is relatively small.

Sediment/sludge removal is required in order to sustain sedimentation pond capacity. In the event that such removal is not practical, sedimentation ponds should be designed with a capacity large enough to accommodate sedimentation over the appropriate operating period.

10.3.1.2.2 Sediment Traps and Check Dams

Sediment traps and check dams may be useful as intermediate structures between erosion sources and sedimentation ponds or can be employed where sedimentation ponds are prohibited or unfeasible. They should be located within site drainage structures and should not cause channel overflow under design flow conditions. Design and installation should be in accordance with state regulations.

10.3.1.2.3 Silt Fences

Silt fences are temporary structures for detaining sediment-laden overland (sheet) flow long enough that the larger-sized particles are deposited and silt-sized particles are filtered out. State regulatory publications provide design and construction guidance for silt fences, and manufacturers provide similar information for their products. The following are general guidelines for silt fences:

- The drainage area should not exceed 0.25 acres per 100 feet of silt fence length.
- For slopes between 50:1 and 5:1, the maximum allowable upstream flow path length to the silt fence should be 100 feet.
- The filter material should be able to retain at least 75 percent of the sediment.
- The bottom edge of the silt fence should be tied or anchored into the ground to prevent underflow.
- There should be no ponding behind silt fences.
- Silt fences should be regularly maintained.

Appropriate state guidelines should be reviewed prior to installation of silt fences.

10.3.1.2.4 Erosion Control Blankets and Reinforcement Mats

Erosion control blankets can be used to stabilize freshly seeded slopes and drainage or ditches until such time that a cover of vegetation is established. Typically, they are most effective on slopes up to 3:1 and in drainage ditches with slopes up to 20:1. Erosion control blankets typically degrade within 6 to 24 months of installation, depending on their composition (straw, fiber, and plastic systems). Design and installation guidance are available in state regulatory publications and manufacturers' literature.

Reinforcement mats are similar to erosion control blankets, but provide greater protection because of the use of synthetic fibers that reinforce vegetation and result in more erosion-resistant construction. Reinforcement mats are used for steep slopes (greater than 3:1) and channels with slopes in the range of 15:1 to 10:1. Design and installation guidance are available in state regulatory publications and manufacturers' literature.

10.3.1.2.5 Vegetation

Erosion and stream turbidity are best minimized by establishing a protective layer of vegetation on embankment slopes and along exposed ditch surfaces. The establishment of grasses in drainage ditches reduces flow velocity and, consequently, erosion.

Vegetation covers on embankment slopes are not practical until construction has proceeded far enough that relatively stable slope conditions are achieved. Vegetation is further discussed in Section 10.5.5.

10.3.2 Acid Generation and Control

The potential for acid generation from coal refuse materials can be estimated, and measures can be implemented to control acid formation or migration. State regulatory programs vary in terms of prediction methodology and the measures required to control or contain acid mine drainage.

10.3.2.1 Background

Acid generation is principally the result of pyrite oxidation. Pyrites are commonly associated with coal formations and surrounding strata. Several types of pyrites may be present, and the reactivity of different forms varies significantly (Kleinmann, 2000). Acidity is produced by the oxidation of pyrites (sulfide components and iron components), which leads to the dissolution of metals (ferric iron, manganese, and aluminum, and occasionally other metals such as copper, zinc, and nickel). Rock strata may contain carbonate materials that neutralize acidity; however, coal refuse is material segregated from coal and generally includes minimal overburden materials that will neutralize acidity.

Acid mine drainage is a major problem in the northern Appalachian Basin (particularly within the Allegheny Group stratigraphic section) and less significantly in the Midwest (Kleinmann, 2000; Appalachian Regional Commission, 1969; Wetzel and Hoffman, 1989). Kleinmann (2000) provides a discussion of geology, hydrology and prediction of acid generation, including acid-base accounting (static or whole rock analysis) and simulated weathering tests (kinetic testing such as leaching tests in various columns and chamber arrangements). Testing procedures associated with acid-base accounting can be applied to individual samples of overburden and spoil materials for predicting acid generation or reclamation performance. Table 10.2 presents a summary of suggested criteria for interpreting the results of acid-base accounting analysis. While simulated weathering tests are not routinely used for coal mine drainage prediction, they can provide data for estimating the relative concentrations of net acidity, metals and sulfate, and they can be useful for evaluating the effectiveness of various amendments for mitigating problem water quality conditions. Kleinmann (2000) provides a detailed discussion of criteria for determining whether to conduct kinetic testing as well as testing methods.

Mitigation of acid generation can also be accomplished by hydrologic controls that minimize water contact with air and refuse. This typically involves: (1) compaction of the refuse surface, (2) sealing of the refuse surface and diversion of runoff from active disposal areas, and (3) capping and covering of completed refuse disposal areas. The USEPA (2000) developed a best management practices guidance manual for re-mining of refuse disposal sites providing specific guidance related to erosion and sedimentation controls and mitigation of acid generation.

10.3.2.2 Grading, Compaction and Sealing

Grading, compaction and sealing of coal refuse embankment surface areas will minimize the potential for infiltrating water contacting pyrites and thus reduce the potential quantity of acid generation and groundwater migration. Grading facilitates control of surface water flows, and compaction reduces the hydraulic conductivity of the refuse material. Regular sealing of the refuse embankment surface using smooth-drum rolling equipment facilitates runoff and thus reduces infiltration and the generation of acid leachates. Before subsequent placement of additional lifts, the sealed surface should be scarified to enhance bonding between lifts and to minimize potential stratification.

10.3.2.3 Amendments

A number of amendments for neutralizing acidity have been used with coal refuse, including coal combustion waste (lime-containing materials), kiln dust, phosphate rock, lime and other products. The amount of amendment material required for neutralizing acidity is a function of several factors, as described by Kleinmann (2000), USEPA (2000), and Brady et al. (1998). Stewart et al. (1997, 2001) evaluated neutralization and leaching from various blends of combustion waste and acid-producing refuse based upon a series of multi-year unsaturated column experiments. With sufficient combustion ash (20 percent and greater for the cited ash and coal refuse), no evidence of acid conditions was detected and low levels of most metals were observed, although high concentrations of boron and sulfate were reported. In column tests where the combustion ash

TABLE 10.2 SUMMARY OF SUGGESTED CRITERIA FOR INTERPRETING ACID-BASE ACCOUNTING

Criteria	Application	References
Rocks with NNP less than -5 parts/1000 considered potentially toxic.	Coal overburden rocks in northern Appalachian basin for root zone media in reclamation.	Smith et al., 1974, 1976; West Virginia Surface Mine Drainage Task Force, 1979; Skousen et al., 1987
Rocks with paste pH less than 4.0 considered acid toxic.	Coal overburden rocks in northern Appalachian basin for root zone media.	Smith et al., 1974, 1976; Surface Mine Drainage Task Force, 1979
Rocks with greater than 0.5% sulfur may generate significant acidity.	Coal overburden rocks in northern Appalachian basin, mine drainage quality.	Brady and Hornberger, 1990
Rocks with NP greater than 30 parts/1000 and "fizz" are significant sources of alkalinity.	Coal overburden rocks in northern Appalachian basin, mine drainage quality.	Brady and Hornberger, 1990
Rocks with NNP greater than 20 parts/1000 produce alkaline drainage.	Coal overburden rocks in northern Appalachian basin. Base and precious metal mine waste rock and tailings in Canada.	Skousen et al., 1987; British Columbia Acid Mine Drainage Task Force, 1989; Ferguson and Morin, 1991
Rocks with NNP less than -20 parts/1000 produce AMD.	Base and precious metal mine waste rock and tailings in Canada.	British Columbia Acid Mine Drainage Task Force, 1989; Ferguson and Morin, 1991
Rocks with NNP greater than 0 do not produce acid. Tailings with NNP less than 0 produce AMD.	Base and precious metal mine waste rock and tailings in Canada.	Patterson and Ferguson, 1994; Ferguson and Morin, 1991
NP/MPA ratio less than 1 likely results in AMD.	Base and precious metal mine waste rock and tailings in Canada.	Patterson and Ferguson, 1994; Ferguson and Morin, 1991
NP/MPA ratio classified as less than 1 (likely AMD), between 1 and 2 (possible AMD), and greater than 2 (low probability of AMD).	Base and precious metal mine waste rock and tailings in Canada.	Ferguson and Robertson, 1994 Price et al., 1997
Theoretical NP/MPA ratio of 2 needed for complete acid neutralization.	Coal overburden rocks in northern Appalachian basin, mine drainage quality.	Cravotta et al., 1990
NP/MPA ratio used with NP threshold to determine confidence levels for acid producing samples. 80% confidence of no acid production if NP/MPA ratio of 6.5 and NP threshold of 3.3%.	Coal overburden samples from 4 states: PA, WV, TN, and KY.	Bradham and Caruccio, 1995
Use actual NP and MPA values as well as ratios to account for buffering capacity of the system.	Base metal mine waste rock, United States.	Filipek et al., 1991

Note: NP = Neutralization potential
 NNP = Net neutralization potential
 MPA = Maximum potential acidity

(ADAPTED FROM KLEINMANN, 2000)

was insufficiently alkaline or where insufficient ash was combined with the refuse, acid generation ultimately exceeded the neutralizing alkalinity of the ash, resulting in a decline in pH and increased concentrations of metals. Stewart et al. (2001) recommend that careful attention be paid to balancing the acid-generating potential of refuse with the alkalinity of combustion ash. Some practitioners recommend increasing the alkalinity by some factor in order to prevent acidic conditions (Daniels et al., 1996).

Daniels et al. (2002) evaluated various combustion ash and coal refuse mixing strategies (including layering and partial blending) to determine their effectiveness in reducing acidity; they demonstrated the value of blending in alkaline materials as close as possible to the area where acid generation is occurring. Rich and Hutchison (1990) discuss the use of kiln dust for neutralizing combined coal refuse. Use of limestone, oxides, phosphate rock and other materials for neutralization is addressed by Skousen et al. (1998).

If amendments are used, provisions should be included in the design plans to verify that proper placement and/or mixing are achieved. The effect of amendments on the geotechnical characteristics of the refuse materials, particularly the strength and hydraulic conductivity of materials placed in structural embankment zones, should be assessed, as discussed in [Sections 5.1.5](#) and [6.2.3.5](#).

10.3.2.4 Reclamation and Vegetative Cover

Reclamation and vegetative cover following completion of disposal operations provides drainage control and limits contact of the coal refuse with infiltrating water. The USEPA (2000) provides a qualitative discussion of improvements in the control of acid generation associated with reclamation and vegetation and cites supporting quantitative studies. Gentile et al. (1997) describe a cover system for an Illinois refuse disposal facility consisting of a compacted clay liner and protective soil cover designed to reduce infiltration by 84 percent. Meek (1994) describes the use of a PVC liner that reduced acid loads from a spoil pile by 70 percent.

While placement of barriers to infiltration as part of reclamation can address acid generation, provisions such as drainage systems should also be incorporated, so that internal seepage can discharge from the toe of a refuse embankment without raising the phreatic surface.

10.3.3 Water Quality Control

10.3.3.1 Diversion of Runoff

Drainage from undisturbed portions of a watershed should be conveyed around coal refuse disposal facilities to the extent practical using diversions. Thus, the amount of drainage contacting coal refuse and potentially subject to water quality impacts will be minimized. State regulatory guidelines provide criteria for the design and construction of diversion systems for control of runoff from undisturbed areas. While use of diversion ditches for impoundments can assist with controlling runoff, their capacity can only be considered in the impoundment flood routing if they are designed and constructed to handle the associated impoundment design storm (e.g., the Probable Maximum Flood for a high-hazard potential impoundment).

10.3.3.2 Treatment

Treatment of acid mine drainage typically involves neutralization of acidity and precipitation of metal ions to meet applicable effluent standards (USEPA, 1983). To meet the required standards, a variety of treatment methods including active and passive treatment technologies can be employed.

Selection of an active treatment system involves evaluation of the flow rate, pH, total suspended solids, acidity/alkalinity, iron and manganese concentrations, the receiving stream's flow rate and

use, availability of electric power, the distance from the point of chemical addition to the point where the water enters a settling pond, and the volume and configuration of the settling pond. Most active chemical treatment systems consist of an inflow pipe or channel (sometimes a raw water storage pond and aerator for large flows), a storage tank or bin for treatment chemicals, a chemical metering system, a settling pond for precipitated metal oxyhydroxides, and a discharge point for treated water. Table 10.3 presents a summary of chemical compounds used for acid mine drainage (AMD) treatment and an equation for estimating the quantity of chemicals required based on the stream flow and the acidity of the AMD. Aeration enhances oxidation of metals such that chemical treatment is more efficient. Oxidants and pH adjusters are also sometimes used in the oxidation process to enhance metal oxyhydroxide precipitation and reduce metal floc volume. Mechanical surface aerators are generally used for large flows where aeration is required; simpler aeration systems using gravity to cascade water over rocks or splash blocks may be useful in smaller applications. Chemicals for neutralizing acidity are generally selected based on technical and cost factors. Skousen et al. (1998) discuss active treatment system design and costs and provide case studies.

Passive treatment technologies that take advantage of naturally occurring chemical and biological processes to cleanse impacted water and do not require continuous chemical inputs have been developed. The primary passive technologies include constructed wetlands, anoxic limestone drains (ALD), vertical flow systems such as successive alkalinity producing systems (SAPS), limestone ponds, and open limestone channels (OLC). Table 10.4 presents design factors and references for passive treatment systems. Skousen et al. (1998) discuss passive treatment system design and costs and provide case studies.

10.3.4 Water Quality Impacts on Construction Materials

The corrosive nature of coal refuse and leachates from coal refuse makes construction material selection important if facility appurtenant structures are to function as intended for long periods of time

TABLE 10.3 CHEMICAL COMPOUNDS USED IN AMD TREATMENT

Common Name	Chemical Name	Formula	Conversion Factor ⁽¹⁾	Neutralization Efficiency ⁽²⁾
Limestone	Calcium Carbonate	CaCO ₃	1.00	50%
Hydrated Lime	Calcium Hydroxide	Ca(OH) ₂	0.74	95%
Pebble Quicklime	Calcium Oxide	CaO	0.56	90%
Soda Ash	Sodium Carbonate	Na ₂ CO ₃	1.06	60%
Solid Caustic Soda	Sodium Hydroxide	NaOH	0.80	100%
20% Liquid Caustic Soda	Sodium Hydroxide	NaOH	784	100%
50% Liquid Caustic Soda	Sodium Hydroxide	NaOH	256	100%
Ammonia	Anhydrous Ammonia	NH ₃	0.34	100%

Note: 1. The conversion factor may be multiplied by the estimated tons of acid per year to get tons of chemical needed for neutralization per year. For liquid caustic, the conversion factor gives gallons needed for neutralization.

2. Neutralization efficiency is an estimate of the relative effectiveness of a chemical in neutralizing AMD acidity. For example, if 100 tons of acid per year is the amount of acid to be neutralized, then 78 tons of hydrated lime would be needed to neutralize the acidity in the water ($100 \times 0.74 / 0.95$).

(ADAPTED FROM SKOUSEN ET AL., 1998)

TABLE 10.4 DESIGN CONSIDERATIONS FOR AMD PASSIVE TREATMENT SYSTEMS

Treatment System	Raw Water Conditions	Construction	Design Factors to Size Treatment System	References
Aerobic Wetland	Net alkaline water	Overland flow, cattails planted in substrate	<ul style="list-style-type: none"> • 10 to 20 g Fe/m²/d • 0.5 to 1.0 g Mn/m²/d 	Hedin et al. (1993)
Horizontal-Flow Anaerobic Wetland	Net acidic water, generally low flow rate	Horizontal flow above organic substrate	<ul style="list-style-type: none"> • 3.5 g acidity/m²/d • Hydraulic conductivity of substrate generally 10³ to 10⁴ cm/sec • Rate of sulfate reduction (~300 mmol/m³/day) • Hydraulic loading 	Hedin et al. (1993), Eger (1994), Wildeman et al. (1993)
Anoxic Limestone Drain (ALD)	Net acidic water DO, Fe ³⁺ , Al < 1.0 mg/l	Horizontal flow through buried limestone	<ul style="list-style-type: none"> • 15 hours contact time • 6- to 15-cm-diameter limestone • Lifetime limestone consumption 	Hedin et al. (1994)
Successive Alkalinity Producing Systems (SAPS)	Net acidic water	Vertical flow through an organic layer overlying a limestone bed	<ul style="list-style-type: none"> • 15- to 30-cm organic matter with adequate permeability • 15 hours contact time in limestone • Lifetime limestone consumption • 6- to 15-cm-diameter limestone 	Kepler and McCleary (1994)

(SKOUSEN ET AL., 1998)

including abandonment. Table 11.6 lists common construction materials used for facility appurtenant structures and corrosion or deterioration mechanisms. The potential for chemical reaction and for clogging of drainage materials are critical considerations in the design of drainage systems. For drainage structures that are in contact with coal refuse or leachate, measures such as sulfate-resistant cement and coatings applied to metal surfaces should be used, as appropriate.

10.3.5 Hydrogeology

Groundwater recharge, unsaturated groundwater flow and saturated groundwater flow are hydrogeologic mechanisms that can affect migration of coal refuse constituents from a refuse disposal site. Groundwater flow is the primary migration mechanism, as erosion and sedimentation control measures are generally capable of controlling overland flow processes. Table 10.5 presents an overview of the hydrogeologic process and significance of the saturated and unsaturated groundwater regimes. Some hydrogeologic features and their effect on the design of coal refuse disposal facilities include the following:

- Springs – To minimize the potential for contact of water with coal refuse, natural hillside spring flows should be collected and controlled. Spring collection drains provide a means to collect and convey spring water from the source to downstream locations.
- Mine discharges and underground mine workings – In some instances, discharges to and from mines may be important hydrogeologic features, because mines collect and convey groundwater. Similar to springs, discharges from mine openings can be controlled by collection drains that convey the mine water from the source to down-

stream locations. Impoundments may require construction of a barrier to control flow of slurry into the mine workings. Additionally, the underground workings may act as a sink for groundwater migration, including seepage from the impoundment.

- Groundwater – Groundwater flow beneath a disposal site may be affected by seepage from refuse materials. If adverse water quality impacts are anticipated, liner systems and amendments can be used to mitigate these concerns.
- Surface water – Surface-water bodies may be a recharge source or receiving body. Disposal sites located near surface water bodies or impounding facilities may require measures such as liners, cutoffs, and other barriers to protect the hydrogeologic regime.

In addition to provisions for protecting the hydrogeologic regime, state regulatory agencies will require monitoring systems for detecting potential impacts to groundwater quality. This require-

TABLE 10.5 OVERVIEW OF THE HYDROGEOLOGIC PROCESS

Source and Flow Process	Description	References
Recharge	Recharge into the disposal facility may occur from: <ul style="list-style-type: none"> • Infiltration of precipitation and runoff • Seepage from impoundment waters 	Kleinmann, 2000
Unsaturated flow in embankment materials	Unsaturated flow in embankment materials is influenced by the recharge rate and unsaturated hydraulic conductivity and generally migrates vertically toward saturated embankment zones.	Hutchison and Ellison, 1992
Saturated flow in embankment materials	Saturated flow in the embankment materials is influenced by underlying barriers such as foundation materials and internal drainage structures designed to control phreatic levels. Saturated flow generally migrates horizontally along foundation surfaces, although a component of flow can be into foundation soils. A liner system may be employed to restrict this component of flow.	Hutchison and Ellison, 1992
Groundwater flow in embankment foundation soils	Saturated groundwater flow in foundation soils is influenced by underlying aquicludes or bedrock barrier and generally migrates horizontally along such surface, although a component of flow can be into deeper horizons or bedrock. Monitoring well systems are typically employed to monitor groundwater quality conditions beyond the limits of disposal sites.	Hutchison and Ellison, 1992
Groundwater flow in bedrock fracture system	Saturated groundwater flow in the bedrock is influenced by the fracture system (and, in some cases bedrock primary porosity) and generally migrates horizontally toward groundwater discharge zones. Monitoring well systems may be employed to monitor groundwater quality conditions beyond the limits of disposal sites.	Kleinmann, 2000
Groundwater interaction with underground mines	Saturated groundwater flow may interact with underground mines, which may act as a discharge zone. Flow may follow discharge gradients in response to coal seam dip or pressure head within the mine. Monitoring well systems may be employed to monitor groundwater quality conditions.	

ment is usually satisfied through installation of monitoring wells located upgradient and down-gradient from the disposal facility. Guidance for monitoring programs is typically available from state regulatory agencies. General guidance for groundwater monitoring systems is provided by Hutchison and Ellison (1992).

10.4 LINER SYSTEMS

Site-specific factors that should be considered in liner system design are summarized in [Table 10.6](#). Liner systems are generally used for containment in situations where acid generation from coal refuse may impact the groundwater. Liner systems are an option in addition to amendments that can be considered for neutralizing acid generation.

Liner systems for protection of groundwater are cited in some state regulatory guidance for coal refuse disposal. Generally the reference is to a single-component, low-hydraulic-conductivity layer. Liner systems employed for other waste containment systems such as combustion waste (DiGioia et al., 1995) generally comprise multiple layers. The layers from the bottom up typically include: (1) sub-

TABLE 10.6 SITE-SPECIFIC FACTORS TO CONSIDER IN LINER SYSTEM DESIGN

Potential Waste Material Toxicity
<ul style="list-style-type: none"> • Chemical properties of refuse and coal preparation additives • Net acid generation potential • Soluble constituents for anticipated environmental conditions • Special treatment or neutralization procedures utilized • Total mass of soluble constituents
General Water Resource Values at Site
<ul style="list-style-type: none"> • Adequate quality for beneficial use • Adequate quantity for beneficial use • Existing or identified beneficial uses • Probable locations of future beneficial uses
Leachate Availability to the Environment
<ul style="list-style-type: none"> • Waste material characteristics • Thickness of waste • Site climatic conditions • Provisions at closure to restrict infiltration
Site Factors
<ul style="list-style-type: none"> • Topography • Geology, including predictability of uniformity and/or potential for discontinuities • Unsaturated zone thickness, continuity, hydraulic conductivity and natural water content • Potential migration time for seepage to groundwater • Effects of climatic conditions on long-term unsaturated zone mitigation characteristics • Constituent attenuation potential
Waste Disposal Facility Management Practices
<ul style="list-style-type: none"> • Facility type • Waste placement method • Protection of liner system from environmental damage • Controls on the hydraulic head • Risk reduction practices such as placement of underdrains, sub-aerial deposition, limited time of operations • Non-liner barriers such as cutoff walls • Installation of special early warning monitoring systems

(HUTCHISON AND ELLISON, 1992)

grade or cushion materials, (2) leak detection zone, (3) liners (primary, secondary and/or composite), and (4) leachate collection layer.

10.4.1 Design Requirements

Design and performance requirements for liner systems are generally determined by the following (Hutchison and Ellison, 1992):

- Waste material characteristics including chemical composition, grain-size distribution, hydraulic conductivity, and the presence of free liquids.
- Waste disposal facility characteristics including liner hydraulic conductivity, slope of the liner, depth and slope of waste placed on the liner, waste placement method, hydraulic head controls, and the duration of operation for all or portions of the facility.
- Site characteristics including location and depth of the water resource to be protected, unsaturated zone conditions, and climatic conditions.

The potential for release of leachate is a function of the magnitude of the hydraulic head above the liner, the thickness and effective hydraulic conductivity of the liner material (considering the frequency of discontinuities in the liner such as cracks or holes), and the length of time the hydraulic head is applied to the liner. Leachate from coal refuse is generally not reactive with liner materials, but, if organic chemicals or strong bases are used in the coal preparation process and remain present in the waste, the issue of liner material compatibility may need to be addressed.

A liner system generally consists of a single low-hydraulic-conductivity layer (clay soil or geosynthetic material). Clay soil liners may include an overlying protection layer to protect the liner from erosion and desiccation. Where a geosynthetic material is used, an underlying cushion layer and an overlying protection layer are usually employed to minimize the potential for penetrations. Additionally, single liner systems may include overlying hydraulic head controls such as a pervious layer above the liner. Such systems reduce the head on the liner and thus further limit potential migration of leachate from the disposal facility. Composite double liners and leachate collection and removal systems are used when redundant systems are needed, although such liner systems are not generally used at coal refuse disposal facilities. [Table 10.7](#) summarizes materials and handling and construction procedures associated with individual components of liner systems.

Major considerations in choosing materials for soil liners are availability and composition. Soils must contain a sufficient portion of clay material such that the constructed liner has low hydraulic conductivity, high plasticity, and chemical stability. Suitable soils are usually classified CL, CH, or SC in the Unified Soil Classification System (USCS) with a liquid limit between 35 and 60 and a plasticity index of 10 or greater. Material for soil liners can consist of on-site or local borrow materials, imported bentonite, or mixtures thereof. To achieve the low hydraulic conductivity required for a containment layer, soils must have consistent properties and may need thorough mixing, preprocessing (e.g., removal of rocks, breakdown of soil clods, addition of bentonite), conditioning (e.g., adjustment of water content), placement in controlled lifts, and compaction. Imperfections such as gravel zones, organics and roots should be removed during construction. Protection against cracking from drying or shrinking may also be required.

The required thickness and hydraulic conductivity of the barrier layer are a function of the hydraulic heads, refuse material characteristics, and state policies or regulations. Typically, requirements for a soil liner or barrier layer are a minimum thickness of 2 feet and a hydraulic conductivity less than 5×10^{-5} cm/sec (≈ 50 ft/yr) and in some applications less than 1×10^{-7} cm/sec (≈ 0.1 ft/yr). Variations from these criteria are generally dependent upon in-situ conditions.

TABLE 10.7 AVAILABLE MATERIALS OR PROCEDURES FOR LINER SYSTEM COMPONENTS

A. Low-Hydraulic-Conductivity Liners

- A.1 Low-Hydraulic-Conductivity Natural Soil or Rock – Natural soils or rock may be used as a low-hydraulic-conductivity liner so long as it is possible to demonstrate by field investigations that the material is continuous and of sufficient thickness and properties over the entire area requiring the liner. This demonstration may be particularly difficult for rock because of jointing and fracture conditions.
- A.2 Constructed Low-Hydraulic-Conductivity Liners – Low-hydraulic-conductivity liners that are constructed beneath a mine waste disposal facility may consist of any of the following materials:
- Compacted, low-hydraulic-conductivity soils (e.g., clayey-silt to clay depending upon the required hydraulic conductivity)
 - Soil and bentonite or cement mixtures
 - Pre-formed flexible geotextile impregnated with bentonite or pre-formed, granulated bentonite laminated to a geomembrane, referred to as geosynthetic clay liner (GCL)
 - Pre-formed flexible membrane liners made from a variety of available polymeric material, generally referred to as geomembranes; varying in thickness from about 20 to 100 mils
 - Field-applied liners, varying from about 80 mils of spray-on asphaltic materials to 6 inches of conventionally-placed asphaltic materials
 - Composite liners, consisting of combinations of soil and geomembrane low-hydraulic-conductivity layers
- A.3 Waste Material – Settled or mechanically placed tailings often have a low hydraulic conductivity and can be used as part of the long-term liner system, provided the tailings serve one of the low-hydraulic-conductivity liner functions.
-

B. Cushion or Liner Protection Materials

- B.1 Geotextiles – Synthetic geotextile materials varying in weight from 4 to 20 ounces per square yard may be used above or below geomembranes to protect against penetrations from rock particles due to loads from construction activities or the weight of the waste material. The suitability of a geotextile to act as a cushioning layer varies and is defined by the method employed by its fabrication (needle-punch non-woven versus woven).
- B.2 Fine-grained Soil for Geomembrane Protection – Soils varying from clay to sand can also be used to protect most geomembranes from equipment traffic or static loading of the waste material. Small gravel-size material has also been used to protect thick geomembranes. The protective soil must be relatively free of large rock particles that could cause stress concentrations on the liner.
- B.3 Cover Material for Clay Liner Protection – Cover protection may also be required for a compacted soil liner if the liner could be subjected to extreme loads, such as construction equipment traffic, or exposed to drainage or desiccation.
-

C. Hydraulic Head Control Components

- C.1 Free-Draining Gravel Layer – Several inches of free-draining gravel (including coarse sand) are usually adequate to rapidly remove small volumes of leakage. However, thicker layers (8 to 18 inches) are usually placed to facilitate construction and protect the liner layer from being damaged. The waste material itself may serve this purpose if the material is granular, durable and relatively free draining.
- C.2 Perforated Pipes – Closely-spaced perforated pipes can be used to control hydraulic head above the liner. The required spacing is calculated based on the maximum desired head and the flow rate and hydraulic conductivity of the waste material between the pipes.
- C.3 Geocomposite Systems – Composite systems consisting of synthetic drainage associated with geotextile filters have been developed for a wide range of drainage control functions. Performance of these systems under load must be confirmed.
-

D. Leachate Collection and Removal Systems

- D.1 Synthetic Geonet Materials – Geonets are net-like polymer products designed to allow high rates of transverse flow. Typical thicknesses of these materials vary from 0.16 to 0.30 inches.
- D.2 Free-draining Gravel Layer – (See Item C.1)
-

(HUTCHISON AND ELLISON, 1992)

Geomembranes made from high-density polyethylene (HDPE), polyvinyl chloride (PVC) and very low density polyethylene (VLDPE) have been used as liners. Important considerations in the selection of geomembranes are thickness, strength, durability, chemical resistivity, cost, cover material needed for cushioning above and below the barrier, method of construction, and the method for seaming the liner (Hutchison and Ellison, 1992). Most geomembranes are manufactured with ultraviolet inhibitors (e.g., carbon black) and can be expected to last more than 50 years even when exposed to sunlight. Geosynthetic clay liners (GCLs) consisting of bentonite sandwiched between two geotextiles (woven or non-woven synthetic fabrics) that are glued or sewn together or bentonite laminated to an HDPE geomembrane have also been used. GCLs are resistant to damage due to handling during installation, but they lose shear strength as the bentonite is hydrated, thus decreasing stability.

Geotextiles and soil materials above and below the geomembrane layer may be needed for protection against penetrations by underlying rocks or sharp objects during construction. The protective soil layers should be relatively free of large rocks and roots that could cause concentrated stresses in the liner. State agencies can provide guidance on the use of geomembranes and may specify a minimum thickness and requirements for compatibility with the refuse materials.

An effective QA/QC program is essential for installation of soil liners, geomembranes and GCLs. Past failures have been attributed to poor material placement, seaming, and protection (Daniel and Koerner, 1995). Composite systems that consist of a combination of soil and a geomembrane have less potential for quality control problems, but may only be economically feasible when suitable soils are available on site.

Figure 10.1 shows three examples of soil and geomembrane liner designs used at coal refuse disposal facilities. Compacted subgrade, as shown in Figure 10.1a, is acceptable in many situations for containment of coal refuse. Soil liners and synthetic liner systems, as shown in Figures 10.1b and 10.1c, respectively, may be attractive in some situations. Some soil and synthetic liner systems may require a prepared subgrade and protective cover materials.

Other layers can be added to a liner system if warranted, including a leachate collection layer and a leachate detection layer. The leachate collection layer should be positioned above the liner to collect and convey seepage from the refuse and to limit the buildup of hydraulic head on the liner. The thickness and hydraulic conductivity of the leachate collection layer should be designed based upon the potential leachate flow, liner configuration (slopes and other geometry that affect seepage), and any restrictions on hydraulic head associated with the liner. The leachate collection layer typically consists of sand and/or gravel designed to be more hydraulically conductive than the waste itself. Geotextiles may be used between this layer and the liner for cushioning and to improve stability.

A network of perforated pipes is sometimes provided within the leachate collection layer to increase capacity, and these pipes must be properly designed to withstand crushing under the embankment weight. The leachate collection layer typically drains to one or more central collector or header pipes. Solid-wall pipes convey the leachate from the disposal area to holding areas for eventual treatment (if required) and discharge. Manholes may be installed at bends and at regular intervals for pipe inspection and cleaning; cleanout fittings may also be used.

Geonets and geocomposite drainage products have been used in some applications for leachate collection (DiGioia et al., 1995) if chemical compatibility and flow capacity under the applied load is acceptable. These products are also sometimes used for leak detection zones beneath the primary liner when conditions warrant.

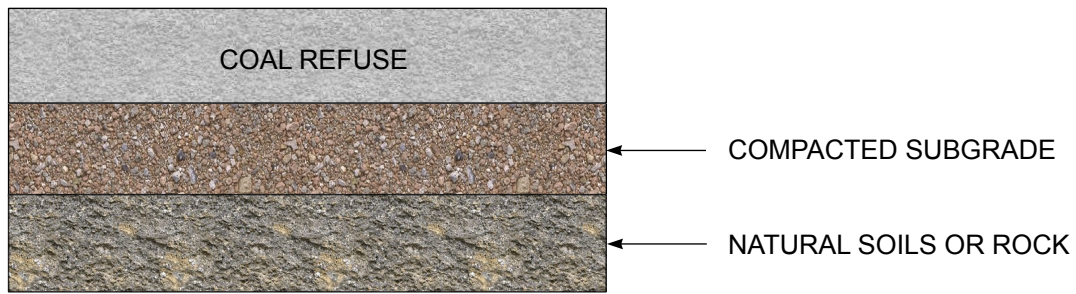

10.1a COMPACTED SUBGRADE

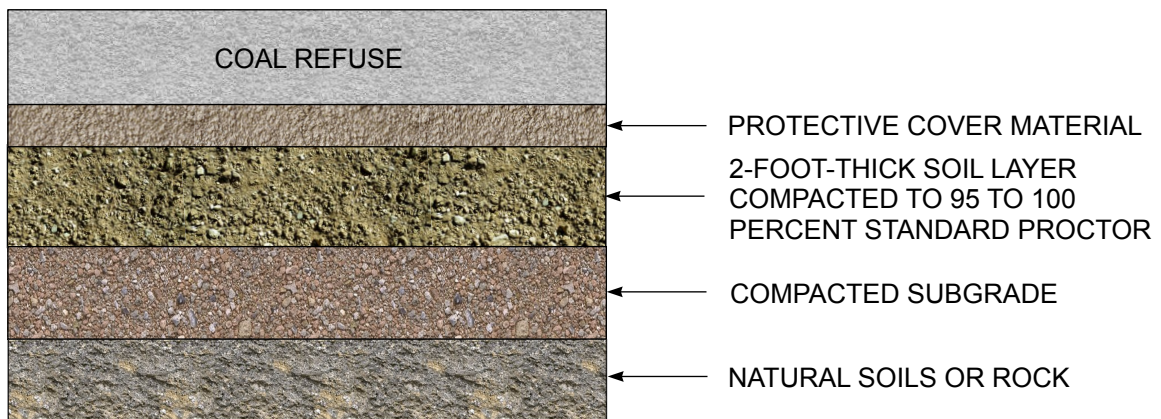

10.1b SOIL LINER

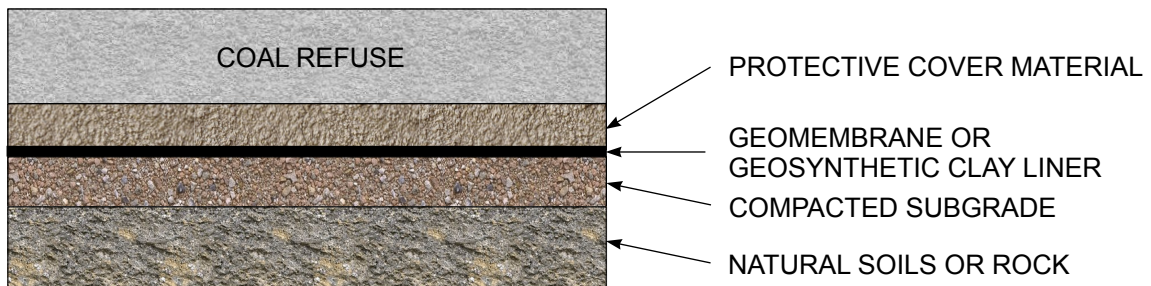

10.1c SYNTHETIC LINER

FIGURE 10.1 LINER SYSTEMS USED AT COAL REFUSE DISPOSAL FACILITIES

10.4.2 Stability

Structural stability of a liner system is a critical element in design. For embankments, the following types of waste stability issues could cause liner damage: (1) sloughing of loose uncompacted material from surficial zones, (2) block failure of the waste material moving laterally with shearing occurring predominantly within the liner system (particularly for sloping liner system), and (3) dynamic slope instability and permanent displacement related to earthquake or other dynamic loading. Liner damage in the vicinity of the impoundment can arise from erosion due to slurry discharge or from natural runoff, as well as instability of adjacent hillsides. A more detailed discus-

sion of slope stability for situations involving liners is provided in Section 6.6.4. Koerner (2006) also presents procedures for analysis of liner stability. Table 10.8 summarizes stability issues associated with liner system design.

10.4.3 Performance Considerations

Liner system performance is measured in terms of the extent of control of leachate seepage from the refuse disposal facility. Liner system performance is related to the types of waste material present, the hydraulic head, and subsurface conditions, and these factors can mitigate or exacerbate the potential hydrologic impacts. Table 10.9 provides a summary of guidance related to performance

TABLE 10.8 STABILITY CONSIDERATIONS IN LINER DESIGN

Problem	Liner Stress	Free Body Diagram	Required Properties		Typical Factor of Safety
			Geomembrane	Landfill	
1. Liner self-weight	Tensile		$G, t, \sigma_{allow}, \delta_L$	β, H	10 to 100
2. Weight of filling	Tensile		$t, \sigma_{allow}, \delta_U, \delta_L$	β, h, γ, H	0.5 to 10
3. Impact during construction	Impact		I	d, W	0.1 to 5
4. Weight of landfill	Compression		σ_{allow}	γ, H	10 to 50
5. Puncture	Puncture		σ_p	γ, H, P, A_p	0.5 to 10
6. Anchorage	Tensile		$t, \sigma_{allow}, \delta_U, \delta_L$	β, γ, ϕ	0.7 to 5
7. Settlement of landfill	Shear		τ, δ_U	β, γ, H	10 to 100
8. Subsidence under landfill	Tensile		$t, \sigma_{allow}, \delta_U, \delta_L, z$	α, γ, H	0.3 to 10

Legend:

G = specific gravity	β = slope angle
T = tensile force	H = landfill height
t = thickness	γ = unit weight
σ_{allow} = allowable strength	h = lift height
τ = shear strength	α = subsidence angle
I = impact resistance	ϕ = friction angle
σ_p = puncture strength	d = drop height
δ_U = friction coefficient with material above	W = weight
δ_L = friction coefficient with material below	P = puncture force
F_U = friction force upper	A_p = puncture area
F_L = friction force lower	z = mobilization distance

(ADAPTED FROM KOERNER, 2006)

TABLE 10.9 LINER SYSTEM PERFORMANCE FACTORS AND CONSIDERATIONS

Liner Type	Thickness (ft)	Hydraulic Conductivity (cm/sec)	Example Hydraulic Head	Estimated Min. Steady-State Leakage Rate Q(gpad)	Travel Time through Liner (years)	Equations
Clay	2	1×10^{-6}	10	3,500	0.1	$q = k_l \left[\frac{D_t + D_l - h_r}{D_l + D_t} \frac{k_l}{k_r} \right]$
	2	1×10^{-7}	10	510	1	$T = \frac{(n - \phi_i)}{k_l} \left[D_l - (H - h_c) \ln \left(\frac{2D_l + H - h_r}{D_l + H - h_r} \right) \right]$
Geomembrane	Membrane with single perforations of 0.03 cm ² /acre (for liner evaluations)		10	7.9 ⁽¹⁾	NA	$q = \frac{\pi k_s}{4} q_r^2$
	Membrane with single perforations of 1 cm ² /acre (for leakage detection capacity calculations)		10	13.7 ⁽¹⁾	NA	$d = \frac{4}{\pi^2} q_r \exp \left[\frac{-\pi(H - h_r)}{q_r} \right]$

Note: 1. Subsoil hydraulic conductivity = 1×10^{-5} cm/sec.

Legend:

- Q = seepage flow in gallons per acre per day (gpad)
- q = seepage per unit area (length/time)
- k_l = hydraulic conductivity of liner (length/time)
- D_l = thickness of liner (length)
- k_t = hydraulic conductivity of waste (length/time)
- d = diameter of hole in geomembrane (length)
- q_r = reduced specific leakage (length)
- T = travel time
- D_t = thickness of saturated waste (length)
- h_r = soil pore-water pressure below liner (length)
- n = effective porosity (dimensionless)
- ϕ_i = initial in-situ volumetric moisture content (dimensionless)
- h_c = soil pore-water pressure (length)
- k_s = hydraulic conductivity of subsoil (length/time)
- H = depth of ponded liquid (hydraulic head) above top of liner (length)

(ADAPTED FROM HUTCHISON AND ELLISON, 1992)

evaluation and provides some specific examples. Measuring the performance of a liner system typically involves monitoring of drain discharges and down gradient groundwater conditions.

10.5 RECLAMATION

Reclamation requirements vary according to land use, climate, and state regulations. The purpose of this section is to provide general guidelines for reclamation grading, impoundment elimination, soil and topsoil covering, and revegetation of coal refuse disposal facilities.

10.5.1 Design Considerations

The content of a reclamation plan is related to the planned post-mining land use, site terrain and disposal facility configuration, climate, and pre-mining and adjacent area conditions. Generally, post-mining land use is open space and wildlife habitat and may be oriented to specific wildlife species and vegetation biodiversity (e.g., forest and grass land mix). Other land use possibilities, although rarely considered, include agriculture, recreation, and site development. All of these land uses typically require the establishment of persistent, low-maintenance vegetation for controlling erosion. Site access and topography significantly affect future land use, and the engineering properties of the embankment and the method of construction are important if structural foundations are planned. [Table 10.10](#) presents a summary of potential final land uses and related key requirements and considerations.

In evaluating potential land uses, the availability of resources, and specifically soils for revegetation, must be determined. Other resources include water, access roads and existing site infrastructure. Preparation of an inventory of resources is an integral step in the development of a reclamation plan. Because soils are used for a variety of applications besides reclamation (e.g., starter dams, liners, etc.), an understanding of the quantity and quality of soils available at or near the site is essential. During the planning and design phases, geotechnical exploration should include field characterization of soil

TABLE 10.10 POTENTIAL FINAL LAND USES

Land Use Examples	Key Requirements and Considerations
Wildlife Habitat and Open Space	Adequate cover of appropriate vegetation for desired wildlife species.
Agriculture	
<ul style="list-style-type: none"> • Pasture and Hay • Fiber Crops • Tree Nursery 	Agricultural land uses should include assessment for trace elements.
Recreation	
<ul style="list-style-type: none"> • Active Recreation (sports fields, golf courses, ski/biking facilities) • Passive Recreation (hunting, hiking, nature study) 	Access to site, topography, erosion and drainage control.
Site Development	
<ul style="list-style-type: none"> • Commercial and Industrial (buildings, storage areas) • Residential (housing, parks) • Infrastructure (highways, airports) 	Access to site, topography, structural support, erosion and drainage control.

(DIGIOIA ET AL., 1995)

properties such as thickness, texture, and color. Evaluation of soil pH and potential lime requirements during geotechnical laboratory testing of soils will enable improved planning of complex reclamation sites. Analyses related to soil and other material handling should be performed with the capabilities and limitations of the available excavation equipment in mind, so that costs associated with recovery and segregation of soils during excavation, stockpiling, and redistribution are realistic.

Soils in the eastern U.S. and the Midwest tend to be neutral to acidic and, with addition of appropriate amounts of lime and fertilizers, can support plant growth without irrigation if appropriate species are selected. For practical purposes, lime will neutralize soils only to the depth of incorporation (plow depth). If lime cannot be incorporated to a sufficient soil depth, plant species with tolerance to low pH should be selected. Soils from arid or semi-arid regions in the west tend to be high in soluble salts and/or sodium, and revegetation in this material can be challenging. All soils should be tested for nutrient availability before lime and fertilizer application is specified (Page et al., 1982). [Table 10.11](#) presents design considerations for reclamation soils.

10.5.2 Grading

Final grading plans for reclamation should include development of surfaces and slopes in order to achieve effective site drainage and to facilitate access for placement of soil and topsoil, vegetation, and maintenance. While plans for a refuse disposal facility provide an anticipated final configuration and slopes, the facility may not reach its planned capacity prior to reclamation. In such circumstances, a reclamation grading plan providing site drainage (eliminating impounding conditions as necessary) and minimizing erosion potential should be developed. The configuration of embankments, slopes, benches and drainage channels at abandonment is subject to state regulatory criteria, which generally include requirements for overall embankment slopes, benches, and top surface grades.

TABLE 10.11 DESIGN CONSIDERATIONS FOR RECLAMATION SOILS

Support for Plants	Non-toxic for plants, capable of root penetration and storing sufficient amounts of plant-available water
Soil Type and Thickness	Typical regulatory requirements are up to 4 feet in total thickness, with equivalent topsoil placement to pre-mining condition. Alternate cover and growth medium may be considered.
Root Anchorage	For large shrubs and trees, soil thickness of greater than 4 feet may be required for anchorage against wind and gravity.
Water Storage	Field capacity and wilting point can be measured or estimated from texture or grain-size distribution.
Establishment of Vegetation	Ability to add nutrients, pH adjustments, soil conditioners for acceptable growth medium
pH	Most plant species grow best at a pH between 6.0 and 7.5. Soils between pH of 3.5 and 6.0 can be limed; the cause of excessive pH should be determined before adjustments are made.
Salt Stress	Sodium and salt soils can be evaluated using electrical conductivity and sodium adsorption ratio.
Nutrient/Trace Element Availability	Nutrient and toxic element testing (Baker, 1988) can be used to identify fertilizer and amendment requirements.
Species Selection	In addition to soil conditions, species should be selected based on short- and long-term availability of irrigation water, short-term erosion control requirements, and maintenance intensity and methods.
Yield of Vegetation for Land Use	Adequate balance of nutrients and trace metals for sustained yield
Engineering Properties	Acceptable erosion resistance, hydraulic conductivity, load bearing capacity, resistance to traffic, etc.

(ADAPTED FROM DIGIOIA ET AL., 1995)

10.5.3 Impoundment Elimination

Elimination of slurry impoundments requires special measures for grading and reclamation. The impoundment surface may be wet, dry, dessicated, or vegetated, but the underlying materials typically remain soft and can exhibit sudden shearing under equipment operation. The impoundment elimination plan should address factors associated with: (1) fine refuse properties, (2) impoundment size and depth, (3) the presence of water, and (4) the availability of and access to borrow sources for regrading and covering materials. Preparation of an impoundment elimination plan may require characterization of the fine refuse materials (including drainage and consolidation properties), specification of the borrow material for covering the fine refuse, and specification of the equipment for implementing the work. [Section 11.5.2](#) provides guidance for upstream construction that should be considered in developing and implementing plans for covering of an impoundment. The following are typical guidelines for impoundment elimination:

- Drainage toward the impoundment should be collected and routed away, and ponded water should be removed.
- Access into the impoundment area for delivery of borrow materials to cover the fine coal refuse should be developed. This may involve construction of access roads and designation of temporary stockpile areas in preparation for initial pushout of borrow materials over the fine refuse.
- An initial lift of borrow materials should be pushed out over the fine refuse using a bulldozer. This initial lift should typically be between 4 and 6 feet thick, with the lower end of this range more desirable for minimizing displacement of the fine refuse. The pushout should not be performed into standing water, and dewatering measures in the fine refuse (prolonged drying, drainage sumps, wick drains, etc.) may be needed to facilitate placement of the initial lift. The initial lift should be advanced from firm areas along the perimeter of the impoundment, creating a wide area of operation rather than a narrow one. The initial lift should generally be advanced a distance of at least 50 feet before additional lifts are placed or trucks or haulage equipment are allowed onto covered areas. This distance should be maintained until the impoundment surface has been covered, and trucks should generally not be allowed into this zone for delivery of borrow materials. Monitoring should be conducted throughout the initial pushout period.
- Subsequent lifts should be placed in accordance with geotechnical requirements for the disposal embankment and should not exceed a thickness of 2 feet. Generally, material for impoundment elimination is considered placed fill unless structural fill is required by final land use. Depending on the geotechnical design requirements, restrictions on the rate of fill placement may be warranted in order to limit loading and to allow consolidation of the fine coal refuse.
- Should displacement of fine refuse occur during pushout, the following measures should be considered: (1) slowing the advance of the pushout to allow dissipation of pore pressure in the fine refuse, (2) use of low-ground-pressure equipment, (3) improving drainage within the fine refuse (e.g., sumps, wick drains), and (4) stabilization of the fine refuse or reinforcement of the pushout lift using geotextiles or geogrids. If displacement is unavoidable, the impoundment elimination plan should include provisions for containment of the displaced material.
- The material used to cover the fines and eliminate the impounding capability should be cambered such that when settlement occurs due to consolidation of the underlying fines, the surface will always provide positive drainage off the site. The amount of long-term settlement should be estimated based on the consolidation characteristics of the fines.

In the development of an impoundment elimination plan, the safety of equipment operators covering slurry deposits should be addressed as well as monitoring of the work. The following general guidance applies:

- Initial and periodic review sessions covering the procedures and anticipated performance of the initial pushout, delivery of borrow material, and subsequent lift placement should be held by engineering personnel for equipment operators and supervisors.
- The impoundment should be maintained in a dewatered condition to the extent practical.
- Initial pushouts should be restricted to daylight hours or times when the work area is sufficiently illuminated to provide good visibility.
- Radio communication for pushout equipment operators and supervisors should be provided, and it is recommended that equipment operations be within sight of mine personnel during the initial pushout and that operators be provided with flotation devices (e.g., life jackets).
- The work area should be examined frequently for signs of instability such as cracking or sinking, and work should be suspended in areas exhibiting such indications.
- Monitoring of the work should be performed by engineering personnel with an understanding of technical issues such as slope stability, displacement, and deformation.
- Pore pressures within the fine refuse and deformations or displacements may be monitored with instrumentation, if warranted.

10.5.4 Soil and Topsoil Cover

Soil and topsoil cover materials with the properties that meet regulatory requirements for reclamation should be stockpiled and recovered from locations near the disposal facility. While OSM and state regulations typically require 4 feet of soil and topsoil cover, there are situations where a variance in cover thickness may be considered. Also, isolation of the refuse materials from infiltrating water may be necessary. In these circumstances, supplemental materials and/or modified placement procedures may be needed:

- In Appalachian regions, there may be insufficient soil and topsoil for reclamation, and reduced cover thicknesses may be necessary. Dove et al. (1987) and Daniels (2005) evaluated direct seeding and reduced topsoil thickness alternatives to determine the optimal combination of soil amendments and topsoil thicknesses for successful vegetation of refuse with varying levels of potential acidic leachate generation. Daniels (2005) indicates that for moderately acid producing refuse, acceptable vegetation can be established with less than 12 inches of soil cover if lime is added to the refuse surface.
- Alternatives such as bio-solids and combustion ash may be considered. Bio-solids (sewage sludge) can be plowed into refuse surfaces and used to establish an alternative growth medium. Combustion ash can also be applied or mixed into the refuse surface to establish an alternative growth medium.
- If isolation of the refuse materials requires a low-hydraulic-conductivity cap, use of clay or a geomembrane may be appropriate. The evaluation and design of caps generally follows the procedures for liner systems presented in Section 10.4.

Achieving good adhesion of soil placed on refuse surfaces may require special procedures. The refuse surface should be scarified by tracking up and down slopes with a bulldozer, by shallow tillage along contour lines, or by other methods that will loosen the surface. Soil should be placed in a relatively dry condition with low-ground-pressure equipment, avoiding excessive compaction (unless required for construction of a low hydraulic conductivity cap). If soils have a low pH (below 5) and require amendment with lime or gypsum, it may be appropriate to place and amend the soil in lifts, with incorporation (plowing in) of amendments through the entire lift prior to placement of the next lift. [Table 10.12](#) presents a summary of reclamation guidelines (DiGioia et al., 1995).

TABLE 10.12 SUMMARY OF RECLAMATION GUIDELINES

Task	Recommended Guidelines
Application of Lime Gypsum and Fertilizer	Lime and gypsum should be plowed into the entire lift thickness, and fertilizers and other plant nutrient sources should be applied evenly and plowed under within 24 hours and to a depth of at least 2 inches. If seedbed preparation includes creation of furrows, seedbed preparation may be done in concert with fertilizer incorporation. If hydroseeding is utilized, apply no more than 40-80-40 pounds N-P ₂ O ₅ -K ₂ O per acre with seed and do not leave seed and inoculants in contact with fertilizer-containing solutions for more than 1 hour.
Furrowing and Land-Imprinting	Where management of water or reduction in wind or salt stress is desired, deep furrowing (6 to 10 inches), land imprinting, or other methods should be performed. Furrows should be oriented parallel to site contours or on flat surfaces, perpendicular to prevailing winds.
Seedbed Preparation	If the furrowing or land imprinting procedures are performed more than a few days before seeding, or a crust has formed on the soil surface, these procedures should be repeated just prior to seeding.
Seeding and Inoculating	Seeding depths using the drill seeding method should be set for the shallowest seeded species. To maximize the opportunity for biological nitrogen fixation, legume seed can be inoculated with Rhizobium strain specific to the species being sown. Broadcast and hydroseeding work best when the seeds are promptly covered with soil and mulch.
Selection of Planting of Woody Species	The emphasis is on establishment of herbaceous, not woody plants. Guidance on selection, planting, maintenance and specification of woody plants is presented in Vogel (1987) and Himelick (1981).
Mulching and Tacking	Mulch should be applied within a day of seeding and before rain. Straw and/or hay applied at a rate of 3,000 to 6,000 pounds per acre and wood cellulose fiber mulch applied at a rate between 1,200 and 2,500 pounds per acre are acceptable mulch for most purposes. Tacking can be performed by crimping mulch into soil with large disks set along the direction of travel or by application of wood cellulose fiber mulch over the straw/hay using a hydroseeder. Crimping techniques that leave some straw/hay standing up in the soil crease and in rows at right angle to the prevailing wind are desirable for dry, windy sites.
Watercourse Protection	For watercourse protection (swales, ditches) wood excelsior, coconut fiber, nylon, and/or jute blankets should be used according to manufacturers' instructions.
Irrigation	Irrigation should be considered during the establishment year in arid and semi-arid regions and other areas where the gains from improvements in establishment rate and long-term survival outweigh the risk of failure.

(ADAPTED FROM DIGIOIA ET AL., 1995)

10.5.5 Vegetation

Species for vegetation and reclamation should be selected based on their adaptability and tolerance to site climate and soil (or alternative media) conditions and their suitability for the final land use and compatibility with regulatory provisions. Additional considerations include erosion and sedimentation control requirements, the need for irrigation water, and maintenance requirements. To the extent possible, local expertise should be sought for development of vegetation plans for specific land uses. Where available, state erosion and sedimentation publications and university agronomy studies can provide important guidance related to seeding/planting mixtures and cultivation practices. Potential vegetation species and their adaptability to various climates and soil conditions are summarized in [Table 10.13](#) (DiGioia et al., 1995).

In humid regions, winter rye and redtop mixed with more slow-to-establish perennial species such as birdsfoot trefoil and deertongue grass are often used to provide cover. Too high a seeding rate of

TABLE 10.13 CHARACTERISTICS OF COMMON SPECIES POTENTIALLY SUITABLE FOR RECLAMATION

Regions of U.S. (1)	Common Name	Scientific Name and Cultivar(2)	Growth Habit/Forms(3,4)	Growth Season(5)	Native Species(6)	Drainage	Precip. Range(7) (in)	pH Range(7)	Land Uses(8)	Seeding Rate(9) (lb/ac)	Miscellaneous Notes
NC, SC, W	Thickspike Wheatgrass	<i>Agropyron dasystachyum</i>	peren./ grass	cool	yes	poor-well	10-17	5.0-8.5	H, A, R, D	4-6	Sod-forming bunchgrass.
NC, W	Crested Wheatgrass	<i>Agropyron desertorum</i>	peren./ grass	cool	no	well	10-17	5.5-8.5	R, D	4-6	Establishes slowly. Intolerant to flooding. Bunchgrass. Stratify seed.
NC, SW, SC	Tall Wheatgrass	<i>Agropyron elongatum</i>	annual/ grass	cool	yes	poor-well	12-20+	6.0-8.0	H, A	4-6	Use adapted cultivars. Establishes easily. Sod-forming bunchgrass. Boron intolerant.
NC, W	Streambank Wheatgrass	<i>Agropyron riparium</i>	annual/ grass	cool	yes	poor-well	11-19	6.5-8.5	R, D	2-4	Spreads rapidly. Sod-forming.
NC, SC, M, W, NE	Western Wheatgrass	<i>Agropyron smithii</i>	peren./ grass	cool	yes	poor-well	5-20+	4.5-9.0	H, A, R, D	4-6	Use adapter cultivars. Sod-forming.
NC, SC, W	Slender Wheatgrass	<i>Agropyron trachycaulum</i>	peren./ grass	cool	yes	med.-poor	15-20+	6.5-8.5	H, A	2-4	Grows fast, short-lived.
SC, M, NE, S	Redtop	<i>Agrostis alba</i>	peren./ grass	cool	no	med.-poor	20+	4.0-7.5	R, D	2-4	Sod-forming short-lived.
NC, SC, M	Big Bluestem	<i>Andropogon gerardi</i>	peren./ grass	warm	yes	med.-poor	16-20+	5.5-7.5	H, A, R, D	4-8	Use adapted cultivars. Deep roots.
All	Common Oats	<i>Avena sativa</i>	annual/ grass	cool	no	well	10-5	5.5-7.0	H, A, R, D	30-50	Use adapted cultivars. Cover crop. Cold tolerant. Needs N.
S	King Ranch Bluestem	<i>Bothriochloa ischaemum</i>	peren./ grass	warm	no	well	20+	5.0-7.0	A	2-6	Mix with <i>Sercica Lespedeza</i> .
NC, SC, M	Sideoats Grama	<i>Bouteloua curtipendula</i> 'Vaughn' or 'Elreno'	peren./ grass	warm	yes	med.-well	12-20+	6.0-7.5	H, A	2-4	Calcareous soils. Bunchgrass.
NC, SC, W	Blue Grama	<i>Bouteloua gracilis</i> 'Lovington'	peren./ grass	warm	yes	well	8-20	6.0-8.5	H, A, R, D	10-12	Use adapted cultivars. Sod-forming bunchgrass. Animal forage.

TABLE 10.13 CHARACTERISTICS OF COMMON SPECIES POTENTIALLY SUITABLE FOR RECLAMATION
(Continued)

Regions of U.S. ⁽¹⁾	Common Name	Scientific Name and Cultivar ⁽²⁾	Growth Habit/ Forms ^(3,4)	Growth Season ⁽⁵⁾	Native Species ⁽⁶⁾	Drainage	Precip. Range ⁽⁷⁾ (in)	pH Range ⁽⁷⁾	Land Uses ⁽⁸⁾	Seeding Rate ⁽⁹⁾ (lb/ac)	Miscellaneous Notes
All	Smooth Brome	<i>Bromus inermis</i>	peren./ grass	cool	no	med.- well	17-20+	5.5-8.0	R, D	10-15	Use adapted cultivars. Establishes easily for quick cover. Sod-forming.
NC, SC	Buffalo Grass	<i>Buchloe dactyloides</i> Sharps 'Improved' or 'Texoka'	peren./ grass	warm	yes	med.- poor	12-20+	6.5-8.0	H, A, R, D	5-10	Sod-forming, stoloniferous. Stratify seed. Monoecious.
NC, SC, W	Prairie Sandreed	<i>Calamovilfa longifolia</i> 'Goshen'	peren./ grass	warm	yes	well	10-20	6.0-8.0	H, A, R, D	6-9	Sod-forming, rhizomatous.
S	Rhodes Grass	<i>Chloris gayana</i>	peren./ grass	warm	no	med.	20+	4.0-7.0	H, A, R, D	8-12	Very tolerant to salinity. Stoloniferous.
NC, S, SC, NE	Bermuda Grass	<i>Cynodon dactylon</i> Quicksand 'Common'	peren./ grass	warm	no	med.- poor	16-25+	4.5-7.5	A, R, D	3-5	Four-year cover. Rhizomatous and seed spreading.
NC, M, NE, S	Orchard Grass	<i>Dactylus glomerata</i>	peren./ grass	cool	no	med.- well	20+	5.0-7.5	H, A, R, D	5-8	Use adapted cultivars. Bunchgrass.
M, NE, S	Deertongue Grass	<i>Dichanthelium clandestinum</i> 'Tioga' (<i>Panicum</i> c.)	peren. /grass	warm	yes	poor- well	20+	3.8-8.0	H, A, R	6-20	Stratify seed. Wet and dry sites. Establishes slowly.
NC, SC, W	Saltgrass	<i>Distichlis stricta</i>	peren./ grass	warm	yes	med.- poor	14-20+	6.0-8.5	H, R, D	4-9	Salt tolerant.
NC, W	Basin Wildrye	<i>Elymus cinerius</i>	peren./ grass	cool	yes	poor	14-20+	6.0-8.0	H, A, R	4-8	Long-lived bunchgrass.
NC, W	Russian Wildrye	<i>Elymus junceus</i>	peren. /grass	cool	no	med.- well	13-20	6.0-8.0	R, D	4-8	Drought tolerant.
NC, W	Beardless Wildrye	<i>Elymus triticoides</i>	peren./ grass	cool	yes	poor	16-20+	6.0-8.0	H, A, R, D	4-8	Establishes slowly.
W	Boer Lovegrass	<i>Eragrostis chloromelas</i> 'A-84'	peren./ grass	warm	no	med.- well	12-19	6.0-8.0	R, D	4-8	Hot, dry climates. Bunchgrass

TABLE 10.13 CHARACTERISTICS OF COMMON SPECIES POTENTIALLY SUITABLE FOR RECLAMATION
(Continued)

Regions of U.S. ⁽¹⁾	Common Name	Scientific Name and Cultivar ⁽²⁾	Growth Habit/ Forms ^(3,4)	Growth Season ⁽⁵⁾	Native Species ⁽⁶⁾	Drain- age	Precip. Range ⁽⁷⁾ (in)	pH Range ⁽⁷⁾	Land Uses ⁽⁸⁾	Seeding Rate ⁽⁹⁾ (lb/ac)	Miscellaneous Notes
SC, M, NE, S	Weeping Lovegrass	<i>Eragrostis curvula</i> 'Ermelo'	peren. /grass	warm	no	well	20+	4.5-8.0	R, D	1-3	Bunchgrass, short-lived in the NE.
All	Tall Fescue	<i>Festuca arundinacea</i> 'Kentucky-31'	peren./ grass	warm	yes	med.- poor	18-20+	5.0-8.0	R, D	10-12	Use adapted cultivars Bunchgrass Use only endophyte-free varieties for agricultural land uses.
SC, M, NE, S	Red Fescue	<i>Festuca rubra</i>	peren./ grass	cool	no	poor- well	20+	5.0-7.5	A, R, D	4-6	Use adapted cultivars. Establishes slowly. Sod- forming.
W	Galleta	<i>Hilaria jamesii</i> 'Viva'	peren. /grass	warm	yes	med.- well	6-12	6.0-8.0	H, A, R, D	6-10	Very drought tolerant, rhizomatous.
W	Big Galleta	<i>Hilaria rigida</i>	peren. /grass	warm	yes	med.	9-14	6.0-8.0	H, A, R, D	6-10	Very drought tolerant, rhizomatous.
NC, SC M, NE, S	Barley	<i>Hordeum vulgare</i>	annual/ grass	cool	no	med.- well	20+	6.0-7.8	H, A, R, D	10-25	Winter cover crop.
NC, SC, M	Annual (Italian) Ryegrass	<i>Lolium multiflorum</i>	annual/ grass	cool	no	med.- well	20+	5.5-7.5	A, R, D	4-6	Quick cover crop.
SC	Klein Grass	<i>Panicum coloratum</i> 'Selection 75'	peren. /grass	warm	yes	med.	18-20+	6.0-8.0	A, R, D	6-10	Texas.
NC, SC, M, NE, S	Switchgrass	<i>Panicum virgatum</i>	peren./ grass	warm	yes	med.- poor	18-20+	5.0-7.5	H, A, R	2-5	Use adapted cultivars and ecotypes. Blackwell variety is competitive. Rhizomatous. Good winter cover.
S	Bahia Grass	<i>Paspalum notatum</i> 'Pensacola'	peren./ grass	warm	no	med.- well	20+	4.5-7.5	H, A	25-35	Stratify seeds. Sod- forming semi-bunchgrass.
NC, NE, M	Reed Canary Grass	<i>Phalaris arundinacea</i>	peren. /grass	cool	no	poor	18-20+	5.0-7.5	H, A	5-8	Wet sites.

TABLE 10.13 CHARACTERISTICS OF COMMON SPECIES POTENTIALLY SUITABLE FOR RECLAMATION
(Continued)

Regions of U.S. ⁽¹⁾	Common Name	Scientific Name and Cultivar ⁽²⁾	Growth Habit/ Forms ^(3,4)	Growth Season ⁽⁵⁾	Native Species ⁽⁶⁾	Drainage	Precip. Range ⁽⁷⁾ (in)	pH Range ⁽⁷⁾	Land Uses ⁽⁸⁾	Seeding Rate ⁽⁹⁾ (lb/ac)	Miscellaneous Notes
M, NE, S	Timothy Grass	<i>Phleum pretense</i>	peren./grass	cool	no	poor-well	20+	4.5-8.0	H, A, R	4-7	Use adapted cultivars Rhizomatous. Short-lived.
NC, SC, M	Big Bluegrass	<i>Poa ampla</i>	peren./grass	cool	yes	well	12-20	6.0-8.0	H, A	6-10	Bunchgrass. Pheasant nesting habitat.
ALL	Little Bluestem	<i>Schizachyrium scoparium</i> (<i>Andropogon scoparius</i>)	peren./grass	warm	yes	well	12-20+	6.0-8.0	H, A, R, D	4-8	Use adapted cultivars.
NC, SC, M, S, NE	Rye	<i>Secale cereale</i> 'Balbo'	annual/grass	cool	no	well	20+	5.5-7.5	H, A, R, D	30-60	Cover crop.
NC, SC, M, S, NE	Indian Grass	<i>Sorghastrum nutans</i>	peren./grass	warm	yes	med.-poor	15-35	4.0-7.5	R, D	2-4	Sod-forming, short-lived.
SC, S	Johnson Grass	<i>Sorghum Sudanese</i>	annual/grass	warm	no	med.-well	20+	5.5-7.5	A, R, D	15-20	Use adapted cultivars. Cover crop.
NC, SC, W	Alkali Sacaton	<i>Sporobolus airoides</i>	peren./grass	cool	yes	poor-well	6-18	7.0-8.5	H, A, R, D	6-10	Use local ecotypes. Bunchgrass. Needs initial irrigation.
SC, W, M	Dropseed	<i>Sporobolus</i> spp.	peren./grass	cool	yes	med.-well	10-20+	6.0-8.5	H, A, R, D	4-8	Bunchgrass. Seeds prolific.
NC, SC	Cicer Milkvetch	<i>Astragalus cicer</i> 'Lutana'	bien./legume	cool	no	poor-well	18-35	5.5-7.5	R, D	2-5	Drought tolerant, sod-forming. Establishes slowly. Scarify Seed.
NC, M, NE, S	Crown Vetch	<i>Coronilla varia</i>	peren./legume	cool	no	well	23+	5.0-7.5	R, D	5-8	Establishes slowly. Excludes tree seedlings. Emerald variety for dry sites. Boron tolerant.
M, SC, S	Illinois Buffleflower	<i>Desmanthus illinoensis</i>	peren./legume	warm	yes	med.-well	15-20+	5.0-7.5	H, A, D	2-5	Drought resistant.
NC, SC, M, NE, S	Soybean	<i>Glycine max</i>	annual/legume	warm	no	poor-well	25+	5.0-7.0	H, A	30-50	Cash crop. Flooding intolerant.

TABLE 10.13 CHARACTERISTICS OF COMMON SPECIES POTENTIALLY SUITABLE FOR RECLAMATION
(Continued)

Regions of U.S. ⁽¹⁾	Common Name	Scientific Name and Cultivar ⁽²⁾	Growth Habit/ Forms ^(3,4)	Growth Season ⁽⁵⁾	Native Species ⁽⁶⁾	Drainage	Precip. Range ⁽⁷⁾ (in)	pH Range ⁽⁷⁾	Land Uses ⁽⁸⁾	Seeding Rate ⁽⁹⁾ (lb/ac)	Miscellaneous Notes
NC, NE, M, NE, S	Lathco Flatpea	<i>Lathrus sylvestris</i> 'Lathco'	peren./legume	cool	no	med.-well	23+	4.5-7.0	R, D	20	Seeds, toxic, excludes tree seedlings. Establishes slowly.
SC, M, NE, S	Sericea Lespedeza	<i>Lespedeza cuneata</i>	peren./legume	warm	no	well	20+	4.5-7.0	A, R, D	10-20	Use adapted cultivars. Scarify seeds. Woody stems.
SC, M, NE, S	Prostrate Lespedeza	<i>Lespedeza daurica</i> var. <i>schimadai</i>	peren./legume	warm	no	well	20+	4.5-7.0	A, R, D	15-20	Prostrate form used with tree seedlings.
M, NE, S	Korean Lespedeza	<i>Lespedeza stipulacea</i>	annual/legume	warm	no	med.-well	20+	4.5-7.0	H, R	6-12	Persistent cover Iowa-6 variety for cold sites.
All	Birdsfoot Trefoil	<i>Lotus corniculatus</i> 'Empire'	peren./legume	cool	no	poor-well	18-20+	5.0-7.5	H, A, R, D	6-8	Use adapted cultivars. Boron tolerant. Does not cause livestock bloat.
NC, SC, W	Alfalfa	<i>Medicago sativa</i>	peren./legume	cool	no	med.-well	17-20+	6.5-7.5	H, A, R	4-12	Use adapted cultivars. Needs Ca and P. Disease susceptible, flooding intolerant.
All	White Sweet Clover	<i>Melilotus alba</i>	bien./legume	cool	no	well	16-20+	6.0-8.0	A, R	4-7	Invasive and competitive. Scarify seed. May cause livestock bloat.
M, NE, S	Yellow Sweet Clover	<i>Melilotus officinalis</i>	bien./legume	cool	no	well	14-20+	6.0-8.0	A, R	4-7	Invasive. More drought tolerant than <i>M.alba</i> . Scarify seed. May cause livestock bloat.
W, SC	Sanfoin	<i>Onobrychis viciaefolia</i>	peren./legume	cool	no	well	10-16	6.0-7.5	H, A, R, D	10-20	Use adapted cultivars.
M, SC, NE, S	Purple Prairie Clover	<i>Petalostemum purpureum</i> 'Kaneb'	peren./legume	warm	yes	med.	12-18	6.0-8.0	H, A, R, D	6-8	Showy display of flowers.
NC, W	Strawberry Clover	<i>Trifolium fragiferum</i>	peren./legume	cool	no	poor	18-20+	6.0-7.0	A, R, D	2-3	Scarify seed. Provides pasture.

TABLE 10.13 CHARACTERISTICS OF COMMON SPECIES POTENTIALLY SUITABLE FOR RECLAMATION
(Continued)

Regions of U.S. ⁽¹⁾	Common Name	Scientific Name and Cultivar ⁽²⁾	Growth Habit/ Forms ^(3,4)	Growth Season ⁽⁵⁾	Native Species ⁽⁶⁾	Drainage	Precip. Range ⁽⁷⁾ (in)	pH Range ⁽⁷⁾	Land Uses ⁽⁸⁾	Seeding Rate ⁽⁹⁾ (lb/ac)	Miscellaneous Notes
NC, W	Alsike Clover	<i>Trifolium hybridum</i>	peren./legume	cool	no	poor-well	18-20+	5.0-7.5	H, A, R	3-5	Attracts bees. Short-lived.
SC, S	Crimson Clover	<i>Trifolium incarnatum</i>	bien./legume	cool	no	med.	20+	5.5-7.0	A, R, D	15-25	Cover crop, but persistent with adapted cultivars.
NC, SC, W	White Clover	<i>Trifolium repens</i>	peren./legume	cool	no	med.	18-2+	6.0-7.0	H, A, R, D	2-4	Sod forming. Attracts bees.
S, SC	Arrowleaf Clover	<i>Trifolium vesiculosum</i>	annual/legume	cool	no	med.	20+	5.0-7.0	H, A	10-15	Use adapted cultivars. Persistent cover.
NC, SC, W	Hairy vetch	<i>Vicia villosa</i>	annual/legume	cool	no	well	18-20+	5.0-7.5	R, D	20-30	Sod-forming cover crop.
All	Common Yarrow	<i>Achillea millefolium</i>	peren./forb.	warm	yes	med.-well	10-20+	5.0-6.0	H, R, D	1-2	Forms ground cover. Drought resistant.
W	Western Yarrow	<i>Achillea millefolium</i> landulosa	peren./forb.	warm	yes	med.-well	12-18	6.0-8.0	H, A, R, D	1-2	Drought resistant.
NE, S	Dwarf-eared Coreopsis	<i>Coreopsis auriculata</i>	peren./forb.	cool	yes	well	20+	5.0-7.0	R, D	2-3	Showy display of flowers. Stoliferous.
SC, W	Rattlesnake Weed	<i>Euphorbia albomarginata</i>	peren./forb.	warm	yes	well	14-20+	6.0-8.0	H, R, D	1-2	Cold tolerant.
All	Annual Sunflower	<i>Helianthus annuus</i>	annual/forb.	warm	yes	well	15+	5.0-7.0	H, A, D	6-8	Showy display.
NC, W	Annual Sunflower	<i>Helianthus annuus</i> 'Jaegeri'	annual/forb.	warm	yes	poor-well	6-14+	6.0-8.0	H, A, D	6-10	Showy display.
SC, NC, M, NE, S	Gayfeather	<i>Liatris pycnostachya</i> 'Eureka'	peren./forb.	warm	yes	poor-well	10-20+	6.0-7.5	H, A, R, D	2-4	Showy display. Drought resistant.
M, SC, NE, S	Smartfeed	<i>Polygonum pennsylvanicum</i>	annual/forb.	warm	yes	poor	15+	5.0-7.0	H, A	10-12	Wet sites. Roots at nodes. Scarify seed.
NC, SC, M, NE, S	Coneflower	<i>Ratibida columnifera</i> 'Sunglow'	peren./forb.	warm	yes	poor-well	16+	6.0-7.5	H, A, R, D	2-4	Showy display of flowers.

TABLE 10.13 CHARACTERISTICS OF COMMON SPECIES POTENTIALLY SUITABLE FOR RECLAMATION
(Continued)

Regions of U.S. ⁽¹⁾	Common Name	Scientific Name and Cultivar ⁽²⁾	Growth Habit/Forms ^(3,4)	Growth Season ⁽⁵⁾	Native Species ⁽⁶⁾	Drainage	Precip. Range ⁽⁷⁾ (in)	pH Range ⁽⁷⁾	Land Uses ⁽⁸⁾	Seeding Rate ⁽⁹⁾ (lb/ac)	Miscellaneous Notes
NC, SC, W	Four-wing Saltbush	<i>Atriplex canescens</i>	peren./shrub	cool	yes	poor-well	5-15	7.0-8.0	H, A, R, D	8-12	Use adapted ecotypes. Evergreen. Seeds prolific. Drought tolerant. Very salt tolerant.
SC, W	Saltbush species	<i>Atriplex</i> spp.	peren./shrub	cool	yes	poor-well	6-12	7.0-8.5	H, A, R, D	8-12	Some species deciduous.
NC, SC, W	Siberian Pea Shrub	<i>Caragana arborescens</i>	peren./shrub	warm	no	well	12-20+	4.0-8.5	H, A, R, D	1-2	Aboreal, deciduous.
W	Alkali Rabbitbrush	<i>Chrysothamnus nauseosus consimilis</i>	peren./shrub	cool	yes	well	8-18+	6.0-8.0	H, R, D	1-2	Deciduous. Deep roots.
NC, SC, W	Russian Olive	<i>Eleagnus angustifolia</i>	peren./tree	warm	no	poor-well	10-20+	6.0-8.0	A, R, D	1-2	Invasive, deciduous, shrubby. N-fixer.
NC, SC, W	Winterfat	<i>Eurotia lanata</i>	peren./shrub	cool	yes	well	6-15+	6.0-8.0	H, A	1-2	Evergreen. Not for Montana.
W	Gray Moll	<i>Kochia Americana</i> 'Vestita'	peren./shrub	warm	yes	poor-well	4-20	6.0-9.0	H, A, R, D	1-2	Alkaline sites.
NC, SC, W	Summer Cypress	<i>Kochia prostrata</i>	peren./shrub	warm	no	well	12-18	6.0-8.0	R, D	1-2	Long-lived very drought tolerant. Prostrate form.
NC, SC, W	Weeping Mulberry	<i>Morus alba</i> 'Kingan'	peren./tree	warm	no	poor-well	12-20+	5.0-6.5	H, R, D	1-2	Deciduous.
NE, M, S, W	Norway Spruce	<i>Picea abies</i>	peren./tree	warm	no	med.-poor	16-20+	5.0-6.0	R, D		Evergreen. Cold sites. Plant seedlings.
All	Lombardy Poplar	<i>Populus nigra</i> 'Italica'	peren./tree	warm	no	well	12-20	5.0-7.0	R, D		Deciduous, short-lived. Plant seedlings.
SC, S	Live Oak	<i>Quercus virginiana</i>	peren./tree	warm	yes	med.	15-20+	6.0-7.0	H, R, D	1-2	Evergreen. Slow growing.
NC, SC, M	Bur Oak	<i>Quercus macrocarpa</i>	peren./tree	warm	yes	med.	10-20	4.0-7.0	H, R, D	1-2	Deciduous. Plant acorns or seedlings.
M, NE, S	Bristly Locust	<i>Robinia fertilis</i> 'Arnott'	peren./shrub	warm	yes	well	15+	3.5-7.5	H, R, D	2-5	Deciduous. Forms thickets. N-fixer. Scarify seed.

TABLE 10.13 CHARACTERISTICS OF COMMON SPECIES POTENTIALLY SUITABLE FOR RECLAMATION
(Continued)

Regions of U.S. ⁽¹⁾	Common Name	Scientific Name and Cultivar ⁽²⁾	Growth Habit/ Forms ^(3,4)	Growth Season ⁽⁵⁾	Native Species ⁽⁶⁾	Drainage	Precip. Range ⁽⁷⁾ (in)	pH Range ⁽⁷⁾	Land Uses ⁽⁸⁾	Seeding Rate ⁽⁹⁾ (lb/ac)	Miscellaneous Notes
All	Black Locust	Robinia pseudoacacia	peren./ tree	warm	yes	poor-well	15+	4.0-7.5	R, D	1-3	Deciduous. N-fixer. Scarify seed. Most common reclamation tree.
SC, W	Tamarisk species	Tamarix spp.	peren./ shrub	warm	no	poor-well	8-20	6.5-7.5	H, R	1-2	Aboreal, evergreen.

Note: 1. Regions of the U.S.:

M = mid-western states (IA, IL, IN, KY, MI, MN, MO, OH, WI)
 NC = north-central states (ND, NE, SD)
 NE = northeastern states (CT, DE, MA, MD, ME, NH, NJ, NY, PA, RI, VT, WV)
 S = southern states (AR, AL, FL, GA, LA, MS, NC, SC, TN, VA)
 SC = south-central states (KS, OK, TX)
 W = western states (AZ, CA, CO, ID, MT, NM, NV, OR, UT, WA, WY)

- Species and cultivars may vary for site-specific conditions. Consult local agronomy extension agents.
- Annual species are best suited as cover crops. Perennial species are best for persistent cover.
- Grasses should be planted in combination with legumes and other forbs. Legumes should be inoculated with appropriate rhizobium at five times the recommended rate. Many additional forbs, shrubs, and trees are available and suitable for reclamation.
- Warm season grasses generally are more tolerant of drought and water stress.
- Native distribution noted as occurs in the particular region.
- Ranges are indicated for optimal growth conditions and may be wider for some species.
- Post-closure land uses. Much overlap is possible:
 H = wildlife habitat and open space
 A = agricultural
 R = recreational
 D = site development
- Rate indicated for seed mixtures. Higher rates apply for monotypic stands. Seeding rates and mixes should be determined by site-specific conditions. Consult local agronomy agents.

(DIGIOIA ET AL., 1995)

the quick-cover species may choke out and prevent successful long-term establishment of perennial species. A balance between short-term erosion control from quick-cover annuals and long-term self-sustaining perennials can be achieved by two-step seeding. This involves an initial dense planting of quick-cover annuals, allowing them to be winter-killed, and then seeding perennials into the stubble remaining from the annuals the following spring. Plants and recommended cultivation practices for humid regions are discussed in Vogel (1987) and Bennett et al. (1978).

In arid and semi-arid areas, exceptionally drought- and salt-tolerant species should be selected (Packer and Aldon, 1978). Even if adaptable species are used, high seeding and planting densities without supplementary irrigation can lead to excessive water stress and failure. Supplementary irrigation may be necessary until root systems are developed. Furrowing along contour lines and planting in the furrows will generally result in efficient use of irrigation water and natural precipitation.

Selection of vegetation for impounding embankments should take into account potential impacts on dam safety inspection and performance. Inspection of vegetated surfaces of dams and adjacent areas, particularly the crest, downstream slope, toe, and adjacent foundation areas is important, as discussed in [Section 12.3](#). Trees and woody vegetation are detrimental to both inspection and the long-term durability of the embankment. Grasses and shallow rooted native vegetation are the most desirable surface cover for an active impounding embankment and dam. Guidance on this issue is presented in Marks and Tschantz (2002).

Chapter 11

CONSTRUCTION AND DISPOSAL OPERATIONS

The preparation of clear and concise construction drawings, specifications and an operation and maintenance plan to guide contractors and mine personnel is an essential part of coal refuse facility development and operation. Property procurement, selection of hauling and transport equipment, determination of haul road locations, determination of refuse disposal procedures, and scheduling of construction for the various facility components are among the first steps of coal refuse disposal facility planning. These planning steps must reflect long-term operational needs as well as short-term start-up requirements.

Communication of this information to the personnel responsible for implementing the plans is essential for effective operations. A basic understanding of the general design concepts and potential safety hazards associated with a disposal facility will increase the likelihood that a program of monitoring and construction control will be conscientiously followed. Regular monitoring and on-site testing will facilitate construction and refuse disposal. Monitoring data related to disposal facility development will aid in compliance with regulatory agency requirements and will facilitate modifications to facility development should changes occur in mine production. [Table 11.1](#) presents a summary of refuse facility operational considerations and related sections in this Manual, as well as references by other authors.

11.1 OPERATIONAL PLANS AND CONSTRUCTION DOCUMENTS

Constructing and operating a coal refuse disposal facility in accordance with regulatory requirements while meeting the mine's operational needs requires careful development of construction plans, specifications and an operation and maintenance plan. Development of these construction documents requires that the designer collect, interpret and analyze data related to design requirements, regulatory requirements, site conditions and the mine's operational needs. Input from the mine operator is critical throughout the design and permitting process so that mine refuse production, particularly start-up rates, are accommodated. Important aspects of refuse disposal facility design should be documented in a design report accompanying the construction documents. This report should present the rationale for facility design, important assumptions and constraints, and engineering calculations supporting facility design.

The plans and specifications should provide essential information and should be organized and presented in such a way that they can be easily interpreted by mine personnel, contractors, regulatory agencies, and monitoring personnel. The operation and maintenance plan should provide important

TABLE 11.1 REFUSE DISPOSAL OPERATIONS

Operational Considerations	Manual Sections	Supplemental References
I. Operational Plans and Scheduling		
• Determine the scope of activities	11.1 to 11.2	
• Review equipment capabilities	11.3 to 11.5	O'Brien et al. (1996), Hartman (1992)
• Schedule development	11.2	Clough et al. (2008), Day and Benjamin (1991)
II. Equipment Selection and Use		
• For transport of refuse from preparation plant to disposal area	11.3	O'Brien et al. (1996), Day and Benjamin (1991), Hartmann (1992)
• For spreading and compacting refuse	11.4	O'Brien et al. (1996), Day and Benjamin (1991), Hartmann (1992)
• For multiple use in related earth work activities	11.4	USBR (1998), Sherard et al. (1963), Church (1981)
III. Refuse Disposal		
• Disposal as structural fill	11.5	USBR (1991, 1998), Sherard et al. (1963), Leonards (1962), MSHA (2007)
• Fine refuse disposal	11.5	Hartmann (1992), MSHA (2007)
• Combined refuse disposal	11.5	Hartmann (1992), MSHA (2007)
IV. Related Activities		
• Haul road construction and maintenance	11.6	Leonards (1962), Oglesby and Hicks (1982)
• Liner systems (if required)	11.6	USBR (1998)
• Embankment foundation preparation	11.6	Sherard et al. (1963), USBR (1998), Leonards (1962)
• Control of water	11.6	USBR (1998)
• General excavation	11.6	Sherard et al. (1963), Day and Benjamin (1991), O'Brien et al. (1996)
• Placement of earth borrow as structural fill	11.6	Sherard et al. (1963), USBR (1998)
V. Materials Selection for Facility Appurtenances		
• Filters and drains	11.7	MSHA (2007)
• Culverts and decants	11.7	MSHA (2007), FEMA (2005a)
• Concrete structures	11.7	USBR (1987a)
• Gates, valves and other metal works	11.7	USBR (1987a)
• Mine opening and auger-hole seals and drains	11.7	MSHA (2007)
VI. Quality Control and Field Testing		
• Testing of compacted earth and refuse fill	11.8	USBR (1998), Leonards (1962), Sherard et al. (1963)
• Materials testing	11.8	USBR (1998), USBR (1991)

information in a concise and easily understandable format so that it can quickly be used as an efficient reference guide for mine personnel performing construction and conducting construction and performance monitoring activities.

Ambiguous details, terms and statements in the specifications and drawings should be avoided. The extent of information and details provided in the plans and specifications will vary depending upon the size and complexity of the refuse disposal facility. The following sections of this chapter present guidance as to the content that should be provided in plan drawings, specifications and operation and maintenance plans for refuse disposal facilities.

An expansion or modification plan is sometimes prepared for an existing coal refuse disposal facility to address changes in facility construction associated with revisions to production rates or changed design criteria. Such plans typically include construction drawings, specifications, and a design report with supporting engineering calculations. For expansion or modification plans, it is important that an index of drawings citing all remaining original and new plan drawings be provided. Revised drawings should clearly reference appropriate specifications, and a revised set of specifications should be included in the associated submittals. If facility drawings are modified or revised as part of the new submission, it is recommended that a current index and cover sheet be prepared with a complete set of drawings to prevent confusion during subsequent review and construction.

11.1.1 Design Report

The design report should present the background data upon which the design is based, along with critical aspects of the design related to construction, operation, and abandonment. The design report generally includes a discussion of the following:

- Project requirements (disposal facility requirements such as refuse generation rates and anticipated life of mine)
- Existing conditions and history of the site including general geologic setting, environmental setting (wetlands, streams or other sensitive areas) previous mining activities, and climate/weather
- Field investigations such as surficial reconnaissance and geotechnical and environmental explorations
- Laboratory testing of refuse, water, soil, rock, geosynthetic materials, and structural materials
- Geologic and geotechnical site conditions, including assessment of impact of previous and planned mining activities
- Site limitations based upon reconnaissance, explorations and testing results
- Facility development and staging
- Special considerations (e.g., amendments, liner systems, mine bulkheads and barriers, construction issues such as dewatering)
- Equipment considerations (e.g., pumping equipment if needed for meeting impoundment drawdown requirements, equipment for spreading and compaction consistent with coal refuse production when conveyor systems are employed for hauling)
- Geotechnical engineering analyses including slope stability, settlement and seepage analyses (and pillar stability and subsidence analyses if underground mining is a factor)
- Hydrologic and hydraulic analyses (including design storm, dam breach and inundation mapping) and hydraulic structure design

- Structural design and detailed monitoring provisions for buried pipelines and inlet structures
- Environmental issues
- Abandonment requirements
- Monitoring and maintenance requirements (schedules for implementation and maximum recommended readings for instrumentation)
- Design recommendations and limitations

11.1.2 Construction Drawings

Construction drawings for a coal refuse disposal facility are probably the most important component of the construction documents. Construction drawings will likely be referred to more often by mine personnel, inspectors, engineers and regulatory agencies than any other construction documents. Accurate and detailed depiction of refuse facility design will clearly indicate the intent of the design and will facilitate construction of the facility. Construction drawings must provide information as required in 30 CFR § 77.215 and 77.216 and must satisfy applicable state regulatory agency requirements. 30 CFR § 77.216 also indicates specific information that must be presented, including the locations of surface and underground coal mine workings and the depth and extent of such workings within a distance of 500 feet from the perimeter of the facility. Construction drawings generally show initial site development and intermediate construction steps with enlargements or details of critical construction features and delineation of dimensions and materials. The following sections provide guidance as to the type of information and level of detail that should be provided on construction drawings.

11.1.2.1 Title Sheet and Existing Conditions Plans

Construction drawings should include a Title Sheet listing drawings and other project and site reference information. A plan showing existing conditions at the site should be prepared, and each refuse facility structure should be identified on an USGS 7.5-minute or 15-minute topographic quadrangle map as a general location reference. This is a requirement for all impounding facilities per 30 CFR § 77.216. Plan drawings depicting existing conditions at a proposed refuse disposal site should generally be prepared at a scale of 1 inch = 100 feet (state regulatory requirements may be more stringent). Alternate scales (either smaller or larger) may be appropriate provided that existing features can be accurately located and represented and regulatory requirements are satisfied. Existing conditions plans should provide coverage of the proposed refuse disposal area and support areas and an additional 500-foot-wide area around the perimeter of the site.

In general, existing features that impact site development and construction of the refuse disposal facility should be shown on existing conditions plans. The following guideline describes the general level and type of information that should be included:

- Topographic contours of existing ground surface at 5-foot intervals or less (contours at 10-foot intervals may be appropriate for steep slopes)
- Footprint of proposed refuse facility for all proposed embankment stages
- Existing and proposed new underground mine workings within 500 feet from the perimeter of the proposed facility
- Extent and location of spoil piles and surface, auger, or highwall mining beneath the dam and impoundment areas
- Location of coal seam outcrops
- Reported geologic features or observed structures (e.g., joints, hillseams, etc.)
- Surface and subsurface utilities
- Existing refuse disposal facilities

- Property boundaries
- Prospective borrow areas
- Existing dams and embankments
- Delineation of forests/woods and heavy vegetation
- Existing buildings and structures
- Oil, gas and water wells (active and abandoned)
- Watershed limits, streams and wetlands
- Springs, seeps and mine discharges
- Landslide areas, mine subsidence features, and other ground disturbance
- Exploratory boring and test pit locations
- Public roads and mine access/haul roads
- Mine shafts, boreholes, vent holes and other mine openings
- Other identifiable natural or man-made features (e.g., cemeteries, buildings, etc.) that could affect the operation of the refuse facility

11.1.2.2 Initial Site Development Plans

As explained throughout this Manual, extensive site development may be required for preparing a site to receive coal refuse material. To provide a stable embankment foundation and safe working area for the placement of refuse and efficient operation of heavy equipment, site development construction may be necessary. The following items should be considered for presentation on initial site development plans at the same scale or larger than the existing conditions plans:

- Areas requiring clearing, grubbing and topsoil stripping
- Topsoil and excess material stockpile areas
- Utility line modifications or relocations
- Oil, gas and water well modifications or abandonment details
- Areas requiring subsurface drainage such as spring/seep collection systems and other underdrain systems
- Prospective borrow areas
- Stream diversions
- Access/haul road alignments and proposed grading contours
- Location(s) of survey control points
- Foundation and abutment areas requiring special subgrade preparations or treatment
- Barriers or backfill areas for treatment of mine openings (shafts, boreholes, auger holes, drift mine openings) or underground mine workings
- Initial erosion and sedimentation control measures
- Diversion and collection ditch alignments
- Environmental barriers or buffer zones
- Cutoff and key trench location (for impounding facilities)
- Seepage barrier locations and requirements
- General subgrade preparations including benching (“keying”) requirements
- Subsurface drainage (spring, seep or stream drains)
- Limits of liner installation (clay or synthetic) if applicable per state regulations
- Decant pipe (with riser locations and elevations), principal spillway, and emergency spillway alignments

Some of the items listed above will probably require depiction with additional plans and details. To meet both operational and environmental requirements, some larger coal refuse disposal sites may need to have phased initial site development plans. These plans should be organized such that site development requirements are depicted sequentially. Sections 11.1.2.5 and 11.1.2.6 address additional drawings that may be required and the level of detail that should be provided to supplement plan view drawings.

11.1.2.3 Refuse Embankment Construction Plan Views

Proper presentation of refuse embankment designs, whether for an impounding or non-impounding facility, will normally require more than one plan view drawing. As indicated in Chapter 5, coal refuse embankments are typically constructed in stages. Each stage of a coal refuse embankment should be depicted by at least one plan drawing at the same scale or smaller than used in the existing conditions or initial site development plan drawings. Detailed plan views, cross sections, profiles and larger-scale details should be used to depict the design of refuse embankments and appurtenances. The required drawings for impounding facilities (including slurry cell facilities) will generally be greater in number and detail than for non-impounding facilities. Detailed drawings of impounding facilities should normally be prepared at a scale of 1 inch = 100 feet, although a smaller scale may be appropriate for larger sites if sufficient detail is provided in cross sections and enlargements. As a guideline, the following items should be presented on embankment construction drawings:

- Footprint and limits of each embankment stage and associated haul road or conveyor belt system
- Delineation of the embankment and material zones
- Proposed topographic contours of each stage at intervals at 5 feet or less
- Footprint, grades and elevations, and flow direction of internal drains
- Collection and diversion ditch alignments, grades and elevations
- Decant pipe alignment and riser locations
- Decant riser schedule with allowable inlet elevations for each embankment stage
- Spillway location and alignment
- Drainage requirements for the working surface
- Piezometer and other instrument locations
- Tabulation of allowable phreatic surface levels measured at piezometers
- Tabulation of maximum pool level for each stage under design storm conditions
- Anticipated fine refuse level at end of each stage, especially for impounding facilities with upstream construction
- Work area sequence within each stage of construction where multiple zones of placement are specified (upstream, downstream or centerline)
- Construction items and sequence for each stage, including features such as seepage barriers, mine barriers and seals, etc.
- Haul road and conveyor belt locations and planned extensions

The plan view drawings for each construction stage should include references to cross sections and details for complex features of the design.

11.1.2.4 Cross Sections and Profiles

Cross sections and profiles are normally prepared to provide details not depicted on plan views. Cross sections are very useful for delineating the various stages of facility development. Cross sec-

tions are also useful for illustrating complex features of refuse facility design such as cutoff trenches, subsurface drainage/underdrains, decant pipe installations, and subgrade preparations.

Consistent with 30 CFR § 77.216, at least two cross sections including longitudinal and lateral cross sections through the highest and lowest elevations of a refuse embankment must be provided. Additional cross sections may be needed for complex refuse embankments, especially impounding embankments. The number of additional cross sections is dependent on the complexity of the facility design and the construction required for tying into previously constructed features. The following items should be considered for inclusion on refuse embankment cross sections:

- Soil and rock units with meaningful descriptions below and at foundation grade
- Elevations and locations of any underground mines (this may require a separate cross section, as the depth to the mine workings may require too large a scale to depict other items)
- Original ground surface (and existing ground surface if different from original ground surface)
- Foundation improvements and special subgrade preparations
- General subgrade preparations
- Embankment surfaces and slopes depicting material zones, if applicable
- Upstream and downstream slope and abutment protection measures
- Delineation of each embankment stage
- Maximum and minimum crest elevations for each embankment stage
- Anticipated fine refuse level at the end of construction for each embankment stage
- For upstream stages, the approximate mixing zone of coarse and fine refuse associated with pushout and development of the embankment stage
- Maximum normal and design storm pool level for each stage
- Final surface grade upon reclamation including provisions for drainage control
- Underdrains/subsurface drainage features and internal drainage systems
- Decant pipeline and risers
- Spillways, including dimension, peak water surface elevation and erosion protection
- Terraces/benches on embankments
- Piezometer locations with sensing zone elevations
- Proposed support equipment or structures (conveyor belts, load out bins, haul roads, etc.)
- Liner systems
- Design phreatic surface
- Stability analysis results depicting subsurface conditions/properties, critical failure surfaces (circular, block and wedge surfaces) and minimum factors of safety

Profiles are useful when presenting the design of haul/access roads, decant pipe alignments, ditch alignments, and underdrains and other components that extend a great distance laterally. As a guideline, profiles should include the following information:

- Original ground surface
- Proposed/final ground surface
- Grade breaks with corresponding slope designations
- Geometry and layout data (such as radii, point of vertical intersection, etc.)
- Bedding and backfill details for pipes and spillways

- Erosion protection measures for ditches and spillways (if not shown on detailed cross sections)
- Critical subsurface soil and rock conditions and site development requirements

The scale for cross sections and profiles should be the same for both the vertical and horizontal directions, although exaggerated cross section segments may be appropriate at large sites where there is significant relief. The scale should be sufficient for clear and accurate representation of design features. If necessary, more detailed, larger-scaled cross sections should be prepared for critical facility components.

11.1.2.5 Detailed Plan Views and Cross Sections

For instances when the plan view and cross-section drawings for individual stages of a facility do not convey the level of detail for critical design features desired by the designers, larger-scale plan views and cross sections should be prepared. The following are facility components or features for which detailed plan views and cross sections may be needed:

- Cutoff trench/keyway cuts, buttresses and other stabilization structures
- Subsurface drains and underdrain systems including spring/seep drains
- Soil liners and graded filters
- Collection and diversion ditches
- Terraces/benches on the refuse embankment
- Subgrade and foundation preparations
- Treatment provisions (backfill, barrier, drainage, etc.) for mine workings and openings
- Spillways
- Decant pipes and risers, including bedding/backfill zones, thrust blocks, and trashracks
- Stilling basins
- Filter diaphragms
- Haul/access roads
- Piezometers, weirs and other instrumentation
- Embankment and impoundment capping details
- Stream diversions
- Erosion and sedimentation controls
- Culverts and other piping systems

11.1.2.6 Miscellaneous Details and Information

Documentation for impounding refuse disposal facilities should include a stage-area curve and a stage-volume curve for the impoundment and a stage-volume curve for the embankment. For facilities that rely on storage of all or part of the design storm runoff, notation of the maximum decant level inlet, open channel spillway inlet (if present), and the design storm volume (or portion thereof that must be stored) should be included on the appropriate curves to demonstrate that sufficient storage is available without overtopping the embankment. Additionally, the head-discharge curve for the decant and spillway should be presented, if applicable. These plotted data should be provided in the operation and maintenance plan, as discussed in [Section 11.1.4](#).

If special construction methods or items are required, they should be detailed in the drawings. Facility components/details such as berms, pipe beddings, piezometers, V-notched weirs, staff and rain gauges, clear water cells, and sealing of mine openings may require additional drawing details and information related to their installation or construction.

11.1.3 Technical Specifications

A complete set of technical specifications that corresponds directly to the construction drawings should be prepared for the construction of a refuse disposal facility. Similar to the construction drawings, the level of detail required in the specifications is a function of the type and complexity of the refuse facility being constructed. At a minimum, the critical construction requirements that impact dam safety and facility operation, as cited in [Section 11.2.2](#), should be clearly addressed in the specifications. Any information related to construction sequencing or methods that are recommendations, but not requirements, should be cited as such in appropriate locations in the plan.

There are several standardized specification systems ranging from basic to sophisticated. Specifications for refuse disposal facilities must provide sufficient detail that contractors and/or mine personnel can easily and clearly understand the facility design requirements. It is recommended that specifications follow a consistent format. The following are industry accepted standard specification systems that may be applicable and are regularly used for other civil engineering projects:

- CSI by the Construction Specifications Institute
- SPECTEXT[®] by the Construction Sciences Research Foundation, Inc.
- SpecsIntact by the National Aeronautics and Space Administration (NASA)

These specifications are organized in groups and/or divisions that address categories of work such as site development, earth fill, and concrete construction. Each individual specification section normally has three parts: (1) General/Scope of Work, (2) Products and (3) Execution. Appropriate specification sections to suit the needs and requirements of facility design should be chosen from the standardized specifications by the designer. Because of the specialized nature of coal refuse disposal facilities, the organization of the standardized specifications may need to be modified to suit specific construction activities and to reflect construction staging and chronological sequence requirements.

If the designer chooses not to use a standardized specification system, the format of the specifications should include at a minimum the following three parts: (1) General/Scope of Work, (2) Materials/Products, and (3) Construction Requirements/Execution. If necessary for clarification of design requirements, a fourth part titled Method of Measurements may be included. It is ultimately at the discretion of the designer as to the format of the specifications and the level of detail provided. Typically, project specifications will consist of a number of individual specifications, each of which follows the format just described. The following describes the content of each portion of a specification in the above format:

- General/Scope of Work should provide an overall description of the work and construction items covered by the specification. Details including the general construction methods and suggested or required sequence of work progression should be included. Specific construction drawings should be identified to clarify the work covered by the specification. Information concerning related specifications, applicable references, and required submittals should also be provided. It is often useful for this portion of the specification to include a technical description of the outcome or function desired by the designer for the particular section. Administrative and procedural requirements applicable to the work should also be included.
- Materials/Products should specify the requirements of the materials, products and accessories to be utilized for construction. Information such as strength, gradation, composition, and tolerances of the materials should be provided. The desired testing requirements and material certifications to be supplied by the manufacturer should also be provided in this section along with a list of submittals where the engineer's approval is required prior to construction. A listing of prospective manufacturers of

some materials may be helpful. Where possible, standardized material designations from American Association of State Highway and Transportation Officials (AASHTO), American Society for Testing Materials (ASTM), or state and federal agencies should be provided. If substitutions are allowed, it is important that sufficient information is provided to allow for equivalent substitution. Submittals to verify that the appropriate materials/products are being used by the contractor should be specified in this section.

- Construction Requirements/Execution should be detailed and should include specifics as to construction methods and, if appropriate, equipment that meets the designer's requirements. A detailed construction sequence and schedule can be provided along with a description of the final work product desired. Plan view, detail and cross-section drawings should be referenced, along with specifications for related work. When applicable, dimensions and tolerances of construction items should be provided. Oversight, inspections, quality control testing, and reporting requirements should be indicated. Lastly, requirements for inspection of critical aspects of the construction by the designer or other engineers familiar with the design requirements should be included.
- Method of Measurements can be included in a specification to facilitate work progress and to establish benchmarks for payment and scheduling. For most the construction items, methods of measurements can be established using standard measurement units such as length, area and volume. Methods and required accuracy for field measurements should be prescribed. Where unit measurements are not feasible, other performance criteria should be defined.

For a refuse facility, detailed specifications that are carefully linked to construction drawings normally provide the most complete depiction of the design and construction requirements. Each individual specification should complement and be consistent with other individual specifications that make up the total specification package for facility construction. Responsibility for permits for certain activities (e.g., burning or blasting) should be cited in the associated specification. The number of specifications required for a particular refuse facility depends upon the type and complexity of the facility design. It is the responsibility of the designer to determine the number of individual specifications needed to convey the design intent. The following is a list of specification topics that may be appropriate for a refuse disposal facility:

- Survey control and construction documentation
- Clearing, grubbing, stump removal and demolition
- Utility relocation and protection
- Well abandonment (gas and water) and mine opening sealing (boreholes, shafts, vent holes, auger holes, drifts, and slopes as well as subsidence features)
- Control of water and stream diversion
- Temporary erosion and sedimentation control
- Sediment/treatment ponds
- Excavation and earth embankment construction
- Foundation preparation
- Exploration for mine openings and sealing of coal seams (exposing coal seams to locate openings and covering coal seams with non-combustible material)
- Backfilling of underlying mine workings
- Internal drains and underdrains
- Liner system
- Culverts

- Decant pipe and principal and emergency spillways
- Conduit thrust blocks and filter diaphragms
- Stilling basins
- Collection and diversion ditches
- Haul and access roads
- Refuse disposal and construction (including placement, compaction, and testing)
- Concrete structures
- Instrumentation
- Reclamation, seeding, soil supplements and mulching

It is recommended that each set of specifications have a summary or administrative section that identifies and defines the entities (e.g., Mine Owner/Operator, Engineer, and Contractor) involved in the design, construction and operation of the refuse disposal facility and that clearly identifies the roles and responsibilities of each party throughout the construction of the facility. Items such as basic contract descriptions, work to be provided by the owner and use of the site should be included. Additionally, this section should address site safety responsibility. It is also recommended that each set of specifications be accompanied by a copy of the design report along with guidance related to construction methods and sequence of construction.

Generally, an individual familiar with the design and engineering requirements, such as the design engineer, is designated as the Engineer. Also, a representative of the Mine Owner/Operator (Operator) is also identified. Both the Engineer and Operator typically have responsibilities for monitoring, inspection, and reporting.

11.1.4 Operation and Maintenance Plan

An operation and maintenance plan is a guidance document recommended for use by construction and inspection/monitoring personnel during construction and operation of the facility. The intent of an operation and maintenance plan is to provide information routinely needed on a daily basis by mine personnel, contractors and inspectors/monitors for construction and operation of the facility after disposal operations have commenced. The plan should clearly identify the roles of various parties in monitoring and inspection activities and should cite the involvement of a registered Professional Engineer who is familiar with the design (including dam safety criteria) for the structure. Additionally, the representative of the Mine Owner/Operator (Operator) who is responsible for the facility and work with the Engineer should also be identified.

An operation and maintenance plan should also provide guidance regarding evaluation of conformance with the approved disposal plan and actions to be taken when observations, testing or instrumentation data identify suspected adverse conditions or obvious hazardous, unsafe or unacceptable operating conditions. It should be noted that the operation and maintenance plan is not a substitute for construction plans and specifications. A complete set of construction plans and specifications should always be readily available during construction and operation of the facility.

An operation and maintenance plan generally does not contain information related to initial site preparations and development activities, but may provide provisions for the safety of operating personnel and the facility, including the following information:

Embankment Construction

- Construction method (upstream, downstream or centerline) and upstream construction implementation procedure, if applicable

- Summary table of crest elevations for each stage
- Schedule of decant riser inlet elevations applicable for activation during each stage with the corresponding minimum required crest elevation
- Specific equipment, methods and lift thicknesses for refuse placement
- Procedures for upstream construction and allowable pore pressure readings during upstream pushouts
- General grading requirements and slopes for embankment out slopes, working surface, benches and haul/access roads
- Reclamation schedule with general capping information
- Monitoring frequency for refuse generation rates for comparison to rates used for facility design
- Survey control and monitoring frequencies
- Decant pipe deflection monitoring

Handling, Spreading and Compaction Equipment Criteria

- Recommendations and criteria for hauling equipment based upon refuse generation rates as provided by the operator or owner
- Recommendations and criteria for spreading and compaction equipment to achieve optimum lift thicknesses and compaction
- Testing and monitoring requirements (criteria and frequency) for evaluating the effectiveness of handling, spreading and compaction equipment

Instrumentation

- Table listing all instrumentation and site plan showing locations of instruments
- Installation procedures, details, and schedule
- Frequency/schedule of monitoring and measurements with explanation if other than 7-day frequency
- Identification of action levels for instrumentation reading, if appropriate (e.g., design basis phreatic levels at each piezometer location)
- Routine maintenance schedule and procedures
- Responsibility for plotting and evaluating data

Surface Drainage Controls

- Construction sequence for spillways and decants
- Construction sequence for diversion and collection ditches
- Schedule of ditch geometries and lining materials
- Acceptable repair techniques
- Cleanout and maintenance frequencies

Impoundment Pool Monitoring

- Schedule of required freeboard for each embankment stage
- Schedule of decant risers to be activated for each stage with corresponding minimum required crest elevation
- Schedule for relocating slurry discharge point to develop delta above normal pool
- Pumping equipment and operating levels, if appropriate
- Stage-storage and head-discharge curves
- Survey control requirements (pool and delta levels)
- Frequency of measurements

Routine Maintenance

- Vegetation
- Reclamation cover
- Ditches
- Decant pipe risers and emergency and principal spillways
- Outlet areas for decant pipes
- Outlets for internal drains
- Minor erosion
- Instrumentation

General Observations and Data Collection

- Frequency of surficial reconnaissance
- List of specific areas requiring inspection
- Description of unusual conditions or features that should be noted and reported to the Engineer
- Reference to schedule and frequency of instruments to be measured with explanation if other than 7-day frequency
- Blank inspection forms and/or data collection forms tailored for site use

Data Review and Reporting Requirements

- Frequency of data review (including plots of pool, piezometers, and seepage data) by the Engineer and Operator
- Evaluation of conformance factors (embankment alignments, moisture/density test results, surface drainage channel geometries, impoundment freeboard, decant levels and serviceability) or adverse condition indicators (seepage flows, piezometer readings, erosion, slope movement, settlement and subsidence) by the Engineer and Operator
- Appropriate document for noting non-conformance factors and adverse condition indicators (weekly reports, monthly progress reports, annual reports) with recommended courses of action for such situations by the Engineer and Operator
- Summary of regulatory reporting requirements

Emergency Management

- Description of items that constitute a hazardous condition, including MSHA's hazardous conditions program (30 CFR § 77.216-3(e))
- Reporting requirements and contact information
- Emergency Action Plan updating requirements (for significant or high hazard potential impounding embankments)

11.1.5 Calculation Brief

The term "calculation brief," as used herein, refers to an organized compilation of engineering analyses and calculations associated with facility design prepared for documentation and for facilitation of regulatory review. The engineering parameters used in the analyses should be substantiated and assumptions should be supported. In addition to the design report, plans, and specifications, the calculation brief is an important part of the documentation of coal refuse disposal facility design. A calculation brief should include the following:

- Coal refuse production rates (by weight and volume) and anticipated facility life
- Starter embankment and refuse disposal staging (impoundment and embankment volumes by stage)

- Hydrology and hydraulic analyses (sedimentation control, design storm routing, decant design, spillway channel and drainage ditch designs, dam breach analysis)
- Stability analyses (including seismic hazard assessment)
- Settlement analyses
- Seepage analysis and internal drain design (including filter design)
- Surface drainage channel lining design
- Buried conduit structural and durability analysis
- Design of appurtenant structures (trashracks, thrust blocks, stilling basins, etc.)
- Subsidence analysis, pillar stability analysis, breakthrough potential evaluation, and mine barrier design
- Environmental analyses

11.2 PLANNING AND SCHEDULING

Planning and scheduling of operations for coal refuse disposal includes the following:

- Time required for site selection, geotechnical investigation and testing, environmental assessments, preliminary and final design, and for obtaining regulatory permits/approvals
- Stipulations associated with current or future mining, such as anticipated life of mine and mining within or near the embankment and impoundment area
- Current and predicted future rates of production of coal refuse furnished by the Operator
- Anticipated physical and chemical properties of the material to be disposed
- The rate and method of transport or hauling of material to the disposal area
- The capability of the materials handling equipment to place, spread and/or compact refuse
- The planned embankment configuration, crest elevation and impoundment capacity at any given time
- The anticipated pool level and settled fine refuse level at any given time
- Construction timing of facility appurtenances related to disposal operations
- Potential delays or special procedural requirements related to weather, work suspensions, regulatory agency stipulations or other circumstances beyond the control of site personnel.

Construction of some features, such as drainage control structures, which are constructed or extended during the facility operation, may require considerable planning and scheduling if they are to be completed by the mine operator's forces. Otherwise, the services of a construction contractor may be needed for completion of the work in a timely manner.

The above items should be re-evaluated periodically as changes in mining operations occur. Lesser considerations, including those related to specific mine and site locations, are discussed throughout this Manual. Through proper planning and scheduling of the various development aspects of the coal refuse disposal facility, operations can proceed in an economical and efficient manner. Early identification of production changes and their impact on the disposal plan and timely preparation of design modifications will allow more flexibility in meeting long-term disposal requirements.

11.2.1 Planning of Coal Refuse Disposal Operations

Plans for coal refuse disposal operations differ from plans for typical construction projects because they must account for the following:

- The disposal facility will usually be in operation for many years necessitating long-term and somewhat speculative planning and timely modifications as conditions change.
- Disposal operations will occur under a variety of weather conditions. The construction of facility appurtenances must be properly timed to avoid delaying or interfering with disposal operations.
- The configuration and characteristics of a refuse embankment during facility development must suit changing conditions frequently unrelated to the final abandonment condition. For example, at impounding facilities, the impoundment storage plus the spillway outflow must be sufficient in combination to handle the design storm hydrograph at all times.
- Over the entire period of disposal operations, changes in equipment, technology and regulatory requirements may necessitate changes in schedule and operations. On-going reviewing and updating of implementation procedures are required.

Equipment requirements should be evaluated as part of the planning of coal refuse disposal operations. The equipment used for haulage, spreading and compaction should be determined based on production forecasts, and all aspects of the process should be balanced such that the specifications (lift thickness, density, moisture content, grading) for material placement can be met. When conveyors are used to provide haulage to the disposal surface, the equipment must be capable of spreading and compacting the refuse such that lift thickness, moisture content and density specifications are met.

11.2.1.1 Long-Term Planning

Long-term planning for refuse disposal operations is concerned with decisions and actions that affect implementation of the overall general plans discussed in Chapter 4. Items that should be considered in the long-term planning include:

- Anticipated mine life
- Property acquisition
- Proximity to the preparation plant
- Time periods associated with obtaining permits/approvals
- Equipment selection and procurement
- Infrastructure requirements
- Refuse disposal techniques
- Timing for construction of facility appurtenances

Property acquisition often entails lengthy transactions associated with price negotiations and legal documentation. The acquisition of properties for a refuse disposal facility should be based upon the ultimate refuse disposal capacity that will be required over the life of the mine. Acquisition of all necessary property at the initiation of refuse disposal operations may not be required because the facility will not occupy the full disposal area for many years. Thus, an agreement to purchase or lease additional property at a later date may be satisfactory.

The equipment and support structures in place at the start of disposal operations should not only meet short-term needs, but should continue to be fully functional as the disposal area is developed. Selection of hauling equipment based only upon initial disposal requirements can lead to inefficient equipment use before the equipment is fully depreciated. Factors such as haul distance, haul road alignment and grade, and refuse production affect the optimization of equipment selection. Loss of equipment efficiency due to age and wear must also be considered in long-term planning.

Some types of equipment have significantly shorter useful life expectancies than others, and it may be possible to have the replacement and upgrading of site equipment coincide with major changes in the facility.

A key aspect of long-term planning of refuse handling at the point of disposal involves analysis of the spreading and compaction of coal refuse that will be required for construction of the embankment. Achievement of specified compaction requires planning for, acquiring and using suitable equipment.

Planning for construction of facility appurtenances, infrastructure, and related items is particularly important if the disposal of refuse is not to be interrupted during long-term operations. With proper long-term planning, construction can be accomplished with minimum interference with disposal operations.

11.2.1.2 Short-Term Planning

Short-term planning is mainly concerned with current and near-term disposal operations and associated construction activities. Short-term planning should result in:

- Facility development in a manner that does not delay refuse disposal operations
- Completed construction conforming to design and regulatory requirements
- Maximum utilization of on-site equipment and materials
- Control of costs during the completion of all tasks

It is ultimately the facility operator's decision as to what specific planning and scheduling techniques are employed. It should be recognized that short-term planning for the development of coal refuse disposal facilities may differ from long-term planning in several respects. Some short-term construction may be accomplished by the operator using on-site labor and equipment. Therefore, manpower and equipment must be available at the site to accomplish needed construction without interference to mining, coal preparation or refuse disposal activities. Utilizing existing staff and equipment for multiple purposes is an essential part of short-term planning.

Many aspects of operational planning are governed by technical design and/or regulatory requirements. Short-term design storm criteria should be established for facility start-up and abandonment periods, as discussed in [Section 9.5](#). A key aspect of operational planning is maintenance of the embankment configuration and spillway capacity during disposal operations, when long-term design storm criteria must be met. Spillways, decants, drains and other hydraulic appurtenances must be constructed without loss of facility function and with expansions sequenced to maintain safety and environmental control. Periodic expansions of hydraulic structure capacity should be planned such that long-term design storm criteria are met. Any temporary periods during such expansions when flood routing capacity is unavoidably reduced or limited must be minimized. Planning for such expansions should include: (1) construction procedures, (2) evaluation of the impact of the construction on design storm management and the capacity of impoundment and hydraulic structures, (3) provisions for a monitoring program, (4) a schedule for the expansion work, and (5) potential contingent actions in the event of major storms.

Under emergency conditions, it may be necessary to accomplish some tasks in the shortest possible time. Providing increased spillway capacity for an existing impoundment, stopping embankment leakage, or stabilizing a sloughing embankment are examples of such emergency conditions. Using on-site labor and equipment may not provide a satisfactory solution in such circumstances, as the needed manpower and equipment may not be available. Thus, contracting of work, rental of additional equipment, employment of contractors with special skills, or working during adverse weather

conditions may be required, thus increasing costs. Effective short-term planning is important in these situations and can minimize unanticipated expenses.

11.2.2 Scheduling Methods and Application

Scheduling refers to the selection of dates for starting each identified task and the assignment of a period for completion. In other words, scheduling represents the time sequence and duration aspects of planning. The following are industry-accepted techniques that can be used for both long-term and short-term scheduling:

- Intuitive judgment/experience
- Bar chart
- Critical Path Method (CPM)
- Program Evaluation and Review Technique (PERT)

11.2.2.1 Scheduling Data

With any scheduling technique, assumptions and input data greatly influence the outcome. Therefore, it is important that the assumptions and data used to generate the schedule are evaluated and agreed upon by key operational personnel. Otherwise, the results of the scheduling exercise may not be valid and may possibly be misleading. Input data used in short- and long-term scheduling associated with development, construction and operation of a refuse disposal facility may include:

- Mine development and coal preparation plant construction times
- Refuse generation rates (present and future)
- Design and permitting times
- Specialized material lead times
- Equipment delivery lead times
- Contractor lead times
- Site development and support facility construction times
- Start date of refuse generation or date when refuse facility is required to be operational
- Refuse construction milestone dates
- Regulatory requirements for facilities to be capable of handling design storm runoff, especially at start-up and decommissioning

Acquiring the above data requires a thorough understanding of the construction and operation of refuse disposal facilities, and knowledgeable personnel should be consulted in the very early stages of planning for a refuse facility. During the initial phases of planning for a new refuse facility, available data regarding the coal seam to be mined and the proposed preparation process to be employed may not be well known. As the planning process moves forward, refinement of the input data should be performed as new information becomes available.

The operator should utilize as many resources and information sources as practical when performing initial planning and scheduling for a new refuse facility. Initial data for refuse generation rates can generally be obtained from process flow diagrams for the proposed preparation plant or from nearby active preparation plants processing coal from the same coal seam. Permitting requirements and associated approval periods can normally be obtained by contacting the applicable regulatory agencies and design consultants working in the area. Data regarding site development and related construction activities can sometimes be obtained from engineers/consultants and contractors. Once the refuse facility becomes operational and refuse is being actively placed, more detailed site data will be available.

Accurately quantifying refuse generation rates for both coarse and fine refuse is important for both long-term and short-term planning. Refuse generation rates may change gradually or abruptly over the life of a refuse disposal facility. The rate of refuse generation and the ratio of coarse to fine refuse are the governing factors that dictate the construction sequencing and ultimate life of a refuse disposal facility. Accurately knowing the rate of refuse production will allow for better forecasting and budgeting of required site development and support facility construction activities. As mentioned earlier, impounding facilities must be designed such that the design storm hydrograph can be safely retained and/or passed through the spillway. Typically, the embankment crest level must be maintained at a minimum height above the level of the impoundment. Knowledge of the refuse generation rate will facilitate maintaining the required crest level.

An effective method for establishing accurate refuse generation rates is through analysis of periodically collected site topographic data. This method requires at least two sets of topographic data obtained at known dates. The time period between data collection should be sufficient to allow for the placement of a considerable volume of refuse. The two sets of topographic data can then be used to determine the net in-situ refuse volume. The rate of refuse generation is then the net volume divided by the elapsed time. This method is applicable to both slurried fine refuse and coarse refuse. In the case of slurried fine refuse, the receiving impoundment must be sounded to determine the top of settled fine refuse. The frequency for performing such analyses depends upon the mining operations and level of accuracy desired. Annual analysis is consistent with MSHA's annual reporting requirements. It is not unreasonable for refuse rates to be evaluated semi-annually, especially during early phases of facility development. Of course, any time that mining conditions or plant operations change, when the preparation plant accepts coal from different sources, or when the plant is modified, changes in refuse characteristics and production rates must be accommodated. This may entail re-evaluation of engineering properties of the refuse, including the refuse grain-size and compaction testing, in order to evaluate impacts on the strength and hydraulic conductivity of the fill and enable tracking of material placement and embankment construction.

11.2.2.2 Applicability of Scheduling Techniques

Some disposal facility operations are relatively simple and consist of only a few activities or tasks. In these cases, scheduling by managers based upon their past experiences and intuitive judgments may be adequate for efficient implementation of operation plans. As site operations become more extensive and complex, more formal scheduling methods become increasingly valuable for evaluating the economic, technical and time implications of task completion. Bar chart scheduling is the least complicated formal scheduling method and is applicable to most small refuse disposal operations. Large disposal facilities often have many interrelated activities, and for these sites, use of the CPM or PERT scheduling methods may be more suitable.

As the sophistication of the scheduling process increases, management time and costs also increase. Generally, this investment has an early and valuable benefit through reduction of errors and omissions and lessening the degree of management control required during operation. However, it is possible to over-refine a schedule by subdividing the required tasks into too many activities or by projecting the schedule beyond the point where the data provide dependable information.

Often the best approach to scheduling incorporates two or more scheduling methods. For example, short-term more well-defined plans can be scheduled with considerable detail using CPM or PERT, and long-term, more broadly-defined plans can be conceptually scheduled using a bar chart. Intuitive judgment may be used for updating or modifying the more complex schedules.

It is emphasized that regardless of the approach, schedules must be periodically updated. This is especially important for long-term coal refuse disposal, where technology, regulations and equipment capabilities may change with time. Through updating of the schedule, operations can be regu-

larly re-evaluated. Thus, the schedule becomes an effective management tool for decision making and operations planning throughout the entire operation period of the coal refuse disposal facility.

Because each mine operator has unique scheduling requirements and employs different scheduling techniques, it is not feasible to specify scheduling techniques for use at specific types of refuse disposal sites. The most important considerations are that the scheduling techniques employed meet the needs of the mining operation and that the design capacity of the disposal facility and compliance with critical parameters (e.g., freeboard, decant level, crest level) are maintained.

11.3 REFUSE TRANSPORT

Refuse transport systems are used for conveying coal refuse from the preparation plant to the disposal area. The purchase, operation and maintenance of these systems can represent a significant portion of the total cost of refuse disposal. The refuse transport system has impacts upon the construction and layout of the refuse disposal facility and in many cases dictates the type of handling, placement and compaction equipment required. As discussed previously, methods for placing and compacting refuse control the geotechnical characteristics and particularly the strength properties of the in-place refuse. Therefore, it is important that the refuse transport system be carefully evaluated as part of refuse disposal facility planning.

This section discusses effects that the selection of the refuse transport system may have on the geotechnical design and construction of a refuse disposal facility. Other sources should be consulted for the design and selection of refuse transport equipment.

Transport systems for coal refuse disposal operations typically consist of:

- Individual motorized hauling units (on- or off-road haul trucks or scrapers/pans) and associated access and haul roads
- Continuous mechanical arrangements such as conveyor belts
- Continuous hydraulic assemblies and/or pipelines for pumping slurried fine refuse

For both of the first two systems listed above, transport of the refuse typically represents the most significant portion of the disposal costs. However, handling of the refuse at either end of the transport system is also a consideration in the design of a refuse disposal facility. Sections 11.4 and 11.5 discuss equipment for handling, placement and compaction of refuse after it is transported to the refuse disposal site. Typically, loading at the preparation plant is accomplished by dumping from bins, and this is essentially the same for either transport system. Handling of refuse at the point of disposal can vary depending upon the system selected, refuse characteristics, and disposal requirements. Individual hauling units such as trucks can usually place refuse near the final disposal location and thus limit further handling. Conversely, continuous mechanical systems generally require additional refuse movement using hauling units and spreaders at the disposal area. Combinations of continuous mechanical equipment and individual hauling units are usually required to meet the needs of a disposal facility.

The anticipated refuse generation rates and the distance from the preparation plant to the refuse disposal site are the most important considerations in choosing a coal refuse transport system. For relatively low refuse generation rates, individual hauling units (on- or off-road haul trucks) are usually feasible and cost effective for transporting coarse coal refuse. As refuse generation rates increase, the economics begin to favor use of a continuous conveyor belt system for coarse refuse. In either case, slurried fine refuse will require a hydraulic system/pipeline for transport. At mines with low refuse generation rates, slurried fine refuse is sometimes pumped to small cells near the preparation plant or mechanically dewatered. Once the fine refuse reaches a state where it can be handled with excavating

equipment, it is placed in haul trucks and transported to the refuse site for disposal either separately or combined with coarse refuse. With higher refuse generation rates, it may be cumbersome to dewater slurried fine refuse prior to disposal. For this case, slurried fine refuse is normally pumped directly from the preparation plant to the refuse disposal facility. Alternatively, the fine coal refuse may be mechanically dewatered at the preparation plant and transported with the coarse refuse. In any case, it is recommended that the final selection of a refuse transport system or combination of systems be based upon detailed information relative to refuse material characteristics and in-situ refuse compaction and strength requirements.

Although rarely pursued, crushing of coarse refuse and pumping with fine coal refuse has been tried in a few cases. This total refuse pumping system adds complexity to the staged construction of the impounding embankments (recovery of hydraulically placed materials for subsequent construction) and may affect the durability and life of the conveyance piping.

11.3.1 Trucks and Scrapers

Individual hauling units and the haul roads upon which they operate can be considered as an integrated transport system and should generally be addressed in the facility plans and specifications. This section discusses the types of hauling units available, the relative advantages and disadvantages of each, and their applicability to specific site conditions. Haul road characteristics must be considered as part of equipment evaluation. Additional information for such evaluations is provided in [Section 11.6.1](#) and by MSHA (1999) in *The MSHA Haul Road Inspection Handbook*.

Typical hauling units include: rear-dump trucks (conventional type), bottom-dump tractor-trailers, side-dump tractor-trailers and rear-dump tractor-trailers. Hauling units are available for both on-highway use and for more rugged off-highway use. Off-highway scrapers may also be used as hauling units and have the added advantage of being able to self-load and spread the hauled materials. Each type of hauling unit has advantages and disadvantages that must be evaluated with respect to the specific requirements of disposal operations.

Individual hauling units are standard construction equipment. Thus, their capability and flexibility are frequently utilized in embankment construction. They provide a means to effectively deliver fill materials throughout the work area and to provide some compaction if their routing is distributed evenly across the disposal area.

11.3.2 Conveyor Belt Systems

Conveyor belts can be used to transport coal refuse from the preparation plant directly to the disposal area for controlled constructed fill or placement or to intermediate storage areas for subsequent transport by individual hauling units. Conveyor belts are particularly useful in mountainous regions where haul road construction is difficult or where steep grades decrease the efficiency or safety of operating individual hauling units. The evaluation of any transport system is primarily based on a comparative economic analysis of the cost for conveying refuse, but the handling requirements at both ends of the transport system must also be considered.

When conveyor belt systems are used for direct transport of refuse to the working surface of a constructed fill, handling, spreading and compaction equipment must be employed for placement and compaction of refuse. Direct placement of refuse with a conveyor belt and inadequate handling, spreading and compaction equipment (e.g., a dozer with insufficient capacity for spreading given the delivery rate of the conveyor) can result in refuse lifts that are either not horizontal, are too thick, or are otherwise not adequately compacted. Other sources should be consulted concerning the selection and design of conveyor systems.

11.4 HANDLING EQUIPMENT

Handling equipment is usually required at each end of a coal refuse transport system to: (1) load refuse at the preparation plant or point of intermediate storage, (2) haul refuse from a conveyor belt bin to the point of disposal, and (3) spread and compact refuse at the point of disposal. The principal function of the handling equipment is to spread and compact refuse in accordance with the design requirements of the refuse disposal facility so that a stable embankment is constructed. Specifically, handling equipment is used to place and spread refuse uniformly over the embankment's working surface in horizontal lifts with thicknesses and densities consistent with design specifications. The purpose of the compaction specifications is to ensure that the material placed in the embankment has the engineering properties (e.g., strength and hydraulic conductivity) used in the design.

The selection and use of handling equipment to distribute and spread refuse at the point of disposal has a considerable impact on the capability for meeting geotechnical design requirements. If the capability of the distribution and spreading equipment does not at least match the arrival rate of the refuse, layers will be too thick for proper compaction or will not receive an adequate number of passes, and as a result the compacted refuse will have lower strength and be more permeable. As discussed in Section 5.1 and Section 11.5, embankments may be designed with zones having different properties and requirements for different levels of refuse handling, spreading and compaction. For any embankment zone, it is desirable to place refuse in lifts so that the working surface can accommodate heavy equipment during adverse weather conditions and the potential for spontaneous ignition is addressed.

Table 11.2 summarizes the major types of handling equipment that serve various transport systems, excluding loading equipment. For a conveyor belt system, loading at the preparation plant will generally be continuous from relatively small hopper bins. If the transport system comprises individual hauling units (on- or off-highway haul trucks or scrapers), loading at the preparation plant may also be from hopper bins, but in this case, the hopper bins should be sized to accommodate surge storage, particularly if the hauling units operate intermittently. A limited capacity for intermediate stockpiled storage can be provided adjacent to the preparation plant, although this should generally be avoided. Loading of the coal refuse into the hauling units would then normally be performed by front-end loaders.

For conveyor belt systems, refuse must be moved from the downstream end of the transport system to the point of final disposal using hauling and/or spreading equipment. For most transport systems, an off-road haul truck and tractor dozer can be used for hauling and spreading the refuse at the disposal area. Compaction of the refuse can be accomplished with the hauling and spreading equipment and/or with separate compaction equipment. Routing of the hauling and spreading equipment over the refuse can achieve partial compaction if performed systematically. Bulldozers typically will need to make more passes over thinner lifts to achieve the same level of compaction as equipment specifically designed for compaction, and a bulldozer alone can only achieve suitable compaction by many passes over each lift (with overlapping tread coverage) if it is not interrupted by spreading requirements. Thus, matching equipment capacity to the refuse delivery rate, with suitable backup to accommodate downtime, is important and can impact the ability to use only spreading or hauling equipment for compaction.

11.4.1 Loading and Hauling Equipment

Although coal refuse is typically loaded from hopper bins directly into hauling units, loading from a stockpile may be required for transport systems composed of individual hauling units. For general construction or earth-moving operations, the capacity of the loading equipment should be closely matched to that of hauling units to minimize loader slack time and hauler spotting and loading time. To minimize hauler cycle time, the loader should be sized so that it can quickly fill a hauler, even though slack time for the loader may result.

TABLE 11.2 TRANSPORT SYSTEMS AND ASSOCIATED HANDLING EQUIPMENT AT THE POINT OF DISPOSAL

Transport System	Handling Equipment and Use
Off-Highway and On-Highway Haulers	<ol style="list-style-type: none"> 1. Tractor dozer(s) to spread dumped refuse and to construct and maintain haul roads. 2. Compaction equipment for structural fill disposal of refuse – may be supplemented by routing of hauling units.
Scrapers/Pans	<ol style="list-style-type: none"> 1. Compaction equipment for structural fill disposal of refuse – may be supplemented by routing of hauling units. 2. Tractor dozer to shape embankment and assist with construction and maintenance of haul roads.
Conveyor Belt System	<ol style="list-style-type: none"> 1. Tractor dozer to distribute and spread refuse dumped from end of system and to construct and maintain access roads. 2. Short-haul equipment if distance from end of system to point of final disposal is large with tractor dozer to distribute and spread refuse. 3. Compaction equipment for structural fill disposal of refuse.

Note: This list of equipment excludes handling equipment requirements at the preparation plant or other equipment requirements for construction of facility appurtenances other than access and haul roads.

Even though loaders may not be required for typical refuse disposal operations, especially those that utilize conveyor belts and bins for refuse transport, some loading capacity should be available at the disposal facility site. It is probable that loading equipment will periodically be needed for construction of other facility structures. Also, a loader is likely to be used for some unplanned aspect of refuse disposal. For example, a needed repair at some location on the embankment may make it desirable to quickly load and haul disposed refuse from another location. Loading equipment used for such general purposes should be selected on the basis of versatility.

Hauling units are usually employed for transporting refuse from conveyor belts and bins to the point of refuse disposal. These units are normally built for off-road use and can supplement compaction efforts, if used correctly. Individual hauling units are also recommended for facilities where conveyor belts transport refuse directly to the point of disposal. In this situation, if spreading equipment is unable to keep pace with the refuse generation rate, the hauling units can be used to transport refuse to other areas of the embankment working surface to prevent accumulation of refuse at the conveyor belt.

11.4.2 Spreading Equipment

As indicated in [Table 11.2](#), tractor dozers are the commonly-used materials handling equipment serving the point of refuse disposal, regardless of the type of transport equipment used. If the proper number of units are available and they are sized and operated correctly, they can efficiently spread refuse in relatively horizontal layers of controlled thickness, and they can economically move refuse a significant distance. For a tractor dozer to be efficient and economical, an analysis should be performed to size it specifically to site conditions. Equipment manufacturers and experienced construction personnel should have input to the selection process. It may be useful to experiment by trying various sized tractor dozers and dozer blades at the refuse facility under normal operating conditions to determine the most economic and efficient tractor dozer/blade combination.

For coal refuse disposal operations, track-type tractor dozers are generally advantageous because of their greater ability to grip inclined surfaces at refuse embankments and their ability to perform

excavation operations as part of the construction of other facility structures. Low-ground-pressure, track-type tractor dozers are also desirable for situations where low ground pressures are required for coarse refuse pushouts over settled fine refuse at impounding embankments using the upstream construction method. If the disposal surface is relatively flat and well maintained and upstream construction over fine refuse is not required, a rubber-tired tractor dozer will be attractive because of its greater speed and mobility. Detailed information regarding the sizing and capabilities of tractor dozers is provided in Church (1981) and is also available from equipment manufacturers.

Scrapers can be used to transport and spread refuse at disposal sites, minimizing the need for a tractor dozer. However, fine grading of slopes and other site construction activities frequently require the use of dozers.

11.4.3 Compaction Equipment

Compaction that increases density and strength and reduces the hydraulic conductivity of disposed coal refuse is essential for construction of stable embankments. Compaction is intended to achieve a homogeneous fill with relatively uniform properties over the depth of each layer or lift. Most designs and construction specifications for refuse embankments define compaction in terms of density and moisture content and leave equipment selection to the owner or contractor. However, the type of compaction equipment used is directly related to the efficiency and uniformity achieved and can also affect material breakdown. Particles of coal refuse are often susceptible to breakdown, such that following compaction, scarifying measures may be required for achieving lifts that are well kneaded together and have uniform properties.

Embankments for slurry impoundments and the downstream shell used to confine combined refuse or slurry cells typically are designed with a well-compacted, refuse-material zone placed in lifts with specified density and moisture criteria (sometimes referred to as the structural zone) to provide for stability and seepage control. Other zones of these embankments may be designed with less stringent lift thickness or compaction criteria provided that embankment stability is acceptable and the potential for spontaneous combustion is addressed.

Depending upon the specified compaction requirements, the compaction of coal refuse can normally be achieved by the systematic and consistent travel of transport and spreading equipment over refuse that has been placed in controlled lifts generally equal to or less than one foot in thickness. This method of compaction will almost always satisfy compaction requirements associated with control of burning even if the lifts are relatively thick (up to 2 feet as allowed under 30 CFR § 77.215). However, routing of hauling units over the working surface may be insufficient to consistently compact the refuse to meet typical criteria, and periodic test pad demonstrations and compaction testing should be employed to verify effective results if only hauling units are being used. For well-compacted embankments or embankment zones, specifically-chosen compaction equipment and/or procedures should generally be employed in order to achieve consistent and effective compaction.

Table 11.3 presents a general comparison of the compaction capabilities of various types of equipment moving over various refuse lift thicknesses. In all cases, the wheel or track of the equipment must pass over each area several times. Figure 11.1 illustrates this procedure. The number of passes and lift thicknesses required for obtaining various degrees of compaction is further discussed in Section 11.5.1. The resulting effect of compaction should be verified through field monitoring.

The basic types of compaction equipment generally employed at coal refuse disposal sites are:

- Rubber-tired, off-highway hauling unit(s) (preferably loaded)
- Sheepsfoot/segmented pad self-propelled roller (vibratory and non-vibratory)
- Smooth-drum, self-propelled or towed vibratory roller

TABLE 11.3 COMPACTION CAPABILITIES OF TRANSPORT AND SPREADING EQUIPMENT

Equipment	Relative Lift Thickness	Effect of Compaction
On-Highway Hauling Units	Very Thin	Fair to Good depending on size of unit
	Medium	Poor
Off-Highway Hauling Units	Thin	Good Depending on size of unit
	Medium	Fair to Good depending on size of unit
Scrapers:		
Double-Axle Mover	Thin	Fair
Track-Type Mover	Very Thin	Generally Poor – Good for thin lifts if material is clean and granular
Tractors:		
Rubber-Tired Tractor	Thin	Fair
Track-Type Tractor	Very Thin	Generally Poor – Good for thin lifts if material is clean and granular

Note: Proper overlap of wheel or track and multiple passes over each area is required in all cases (Figure 11.1)
The resulting effect of compaction should be field monitored and verified.

Loaded rubber-tired off-highway hauling units are effective for compacting both cohesive and granular materials due to the heavy weight of the loaded equipment concentrated at the relatively small footprint of the tires. Sheepsfoot, self-propelled rollers are generally most effective on cohesive materials with a high percentage of silt- or clay-sized particles. However, if the sheepsfoot roller has a vibratory capability, it will also be effective on granular materials such as coarse coal refuse. Smooth-drum vibratory compactors are most effective on granular materials and are useful for surface sealing to minimize infiltration.

Vibratory rollers, either smooth-drum or sheepsfoot, are better suited for coarser materials containing small amounts of clay-sized particles. According to a study performed on test pads of coarse refuse, Saxena et al. (1984) found that either a vibratory smooth-drum roller or a vibratory sheepsfoot roller were effective for compaction of lift thicknesses up to 1 foot thick. The vibratory action of these types of compactors, which can usually be adjusted, is obviously important for achieving compaction. The vibration associated with the operation of track-type tractor dozers is likely a key component that facilitates the compaction of granular materials, as indicated in Table 11.3. Manufacturers' literature, information in periodicals, and Church (1981) provide information on the compaction force associated with specific types of equipment.

Because the characteristics of coal refuse vary considerably, selection of the most appropriate compaction equipment should be based upon both material and site-specific factors, and the selected equipment should be capable of achieving specified strength and hydraulic conductivity requirements. Vibratory-type compaction equipment has been found to be effective for compacting coal refuse. Sheepsfoot rollers (vibratory or non-vibratory types) have the advantage of crushing and compacting weathered or soft rock in coarse refuse. However, larger pieces of resistant rock may make such rollers ineffective because the feet may strike the rock and lift the roller, preventing compaction of adjacent material. The same effect can occur with smooth-drum rollers. If larger, resistant rocks are prevalent at a site, loaded off-highway haul trucks should be used.

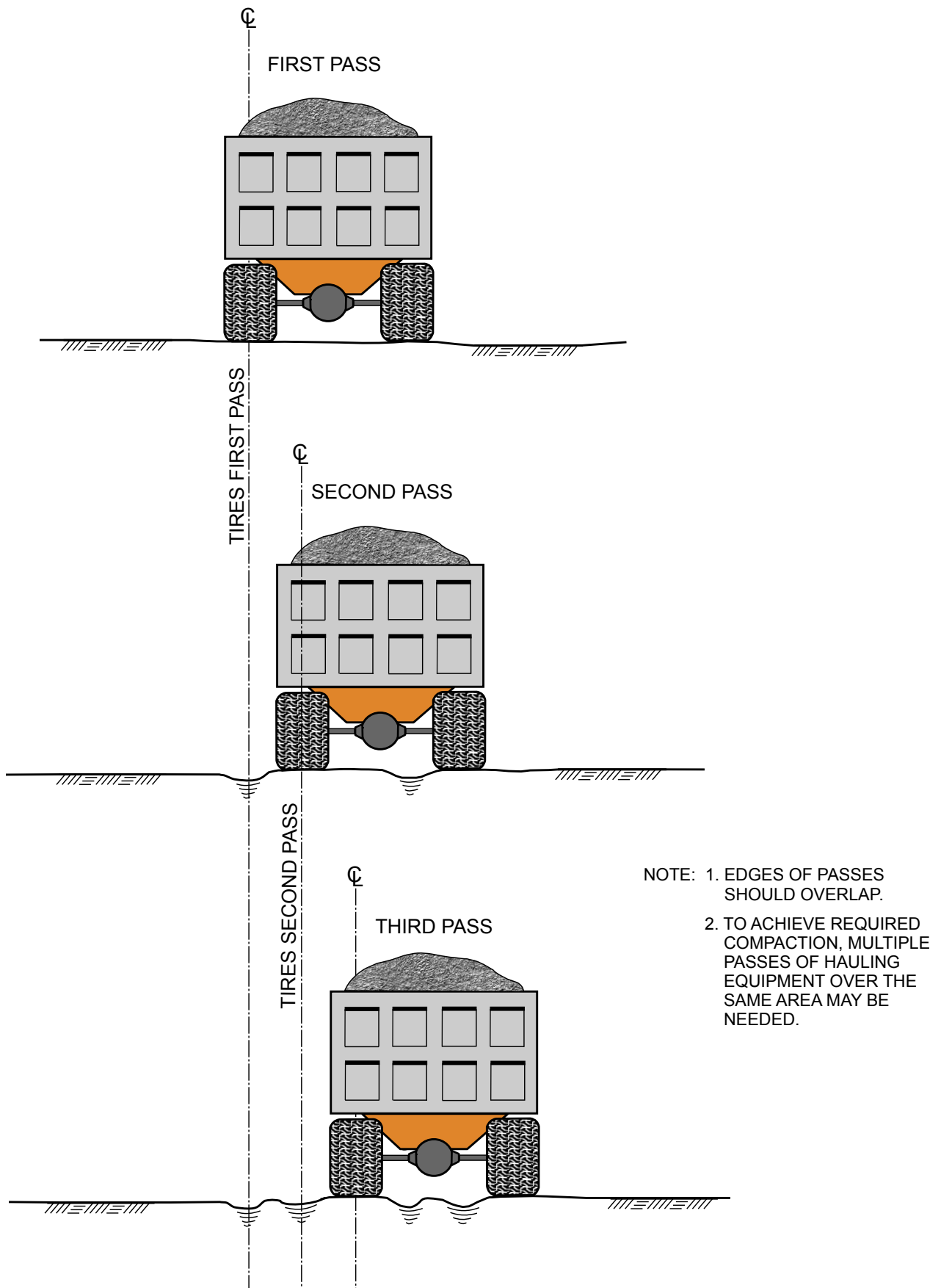

FIGURE 11.1 COMPACTION BY HAULING UNITS USING SUCCESSIVE OFFSET PASSES

Both vibratory and non-vibratory compactors are generally manufactured in self-propelled, towed and pushed models. Similar to the selection of other handling equipment, compactors should be capable of handling the refuse production rate and providing adequate compaction. Evaluation of the performance of compaction equipment should be conducted for the expected refuse placement rates. The effectiveness of any compactor on coal refuse generated at a particular site will not be fully known until field performance has been evaluated through measurement of the in-situ density of the compacted refuse.

The use of spreading equipment such as tractor dozers for compaction is less effective than equipment designed for compaction because less ground pressure is exerted and generally thinner lifts are needed in order to consistently meet specified criteria. Additionally, use of spreading equipment for compaction can result in inconsistent compaction, particularly if multiple dozers are not available to accomplish spreading and compaction as separate operations. If compaction of structural fill with tractor dozers is desired, demonstration test pads should be periodically utilized in conjunction with field compaction testing to establish and document procedures for attaining consistent and acceptable results throughout the structural zone.

11.4.4 Use of Handling Equipment for Related Activities

The adaptability of handling equipment for performing other tasks at a mining site is an important consideration in equipment selection. However, this consideration should be secondary to the capability of the equipment for placing, spreading and compacting refuse. If the handling equipment is suitable for refuse embankment construction and can also be used to construct haul or access roads, clear disposal areas, prepare the embankment foundations, and construct spillways and drainage ditches, there will be a savings in equipment cost. Such equipment will also allow work crews that are not fully utilized on refuse disposal to work on other site construction activities.

Effective refuse disposal should be the predominant handling equipment selection consideration. However, at some facilities, the generated refuse may not be of sufficient quantity to keep handling equipment busy on a full-time basis. For these sites, multiple-use capabilities for the spreading equipment are important.

11.5 CONSTRUCTION AND PLACEMENT OF EMBANKMENT MATERIALS

As discussed in Chapters 5 and 6, the structural portions of a coal refuse disposal facility must be constructed in a controlled manner meeting technical design requirements. This is particularly true for the refuse embankment and its associated drainage controls. Coal refuse disposed in these portions of the facility, as previously discussed, is referred to as constructed or structural fill refuse. Fill at other portions of the facility, where less stringent compaction requirements may apply, is referred to as placed refuse.

Earthen fill or refuse that is placed as structural fill should be spread at a specified lift thickness and compacted to specified density and moisture content criteria such that material properties are consistent with facility design requirements. Placement of structural fill should be performed in generally horizontal lifts. [Figure 11.2](#) shows several correct and incorrect methods of refuse placement. As discussed in Chapters 4 and 5, those portions of the facility that will require structural fill refuse disposal should be identified during site selection and facility planning. After placed refuse has been built up through many lifts, little can be done to densify it to structural fill specifications. Therefore, the impact on future site development of placed refuse fill with lower compaction standards must be fully understood.

11.5.1 Embankment Fill

Embankment fill at a coal refuse disposal facility generally consists of coarse refuse or earth and rockfill borrow materials placed in specified stages or zones. For instance, many impounding facili-

NON-UNIFORM DUMPING FROM TRUCK OR CONVEYOR WITH INADEQUATE SPREADING AND COMPACTION

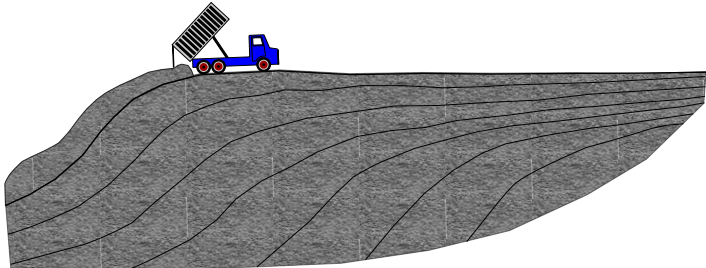

INCORRECT

COMPACTING

SPREADING

DUMPING FROM TRUCK

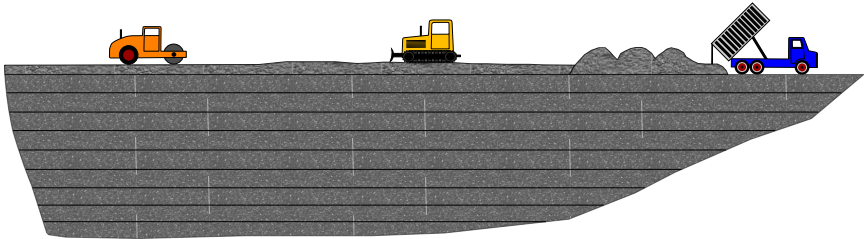

CORRECT

CUTTING AND DUMPING WITHOUT SPREADING AND COMPACTION

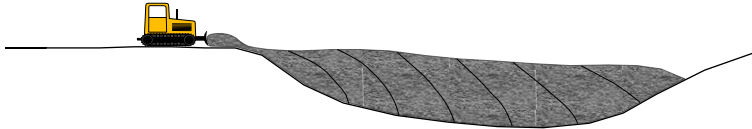

INCORRECT

CUTTING AND SPREADING

COMPACTING IN LAYERS



CORRECT

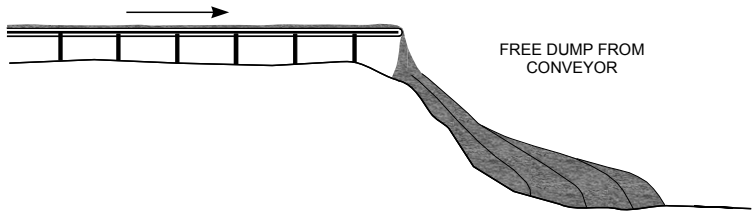

INCORRECT

FREE DUMP FROM CONVEYOR

SPREADING

COMPACTING

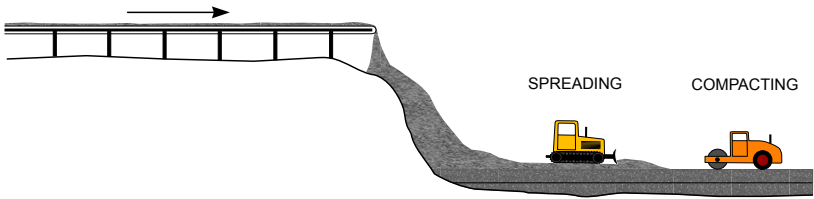

CORRECT

FIGURE 11.2 PROCEDURES FOR CONTROLLED PLACEMENT OF REFUSE

ties consist of an initial stage embankment constructed of soil and rockfill, with subsequent coarse refuse embankment stages that increase the height and capacity of the impounding facility. In many respects, placement and control at the facility embankment are not unlike that for earth and rockfill dams. However, there are major differences in timing because construction extends over the total operational period of the facility, which is usually many years. Differences also occur in materials selection because refuse embankment construction is based on maximum use of refuse and minimum use of borrow materials.

The placement and compaction effort for embankment fill refuse at an impounding facility is generally more stringent than that for a non-impounding facility. In both cases, the refuse should be placed in controlled lifts and compacted as required by the facility plans. Lifts are generally horizontal and extend over a large portion of the embankment.

Compaction of coarse refuse or soils in an impounding facility is intended to produce a well-compacted zone consisting of uniform, consistent and dense lifts. This is accomplished by limiting the lift thickness of the refuse or soil and by compacting the lifts to achieve specified strengths. Guidance for compaction of soil and rockfill materials is available from a number of sources, including Church (1981), DOD (2005), and USBR (1998). Table 11.4 presents published guidance (Church, 1981) for compaction of residual soil, weathered rock, durable rock, and alluvium. As indicated in the table, the compactive effort may be applied by a range of actions including pressure, kneading, impact and vibration. Various compactive actions can achieve compaction, but the efficiency and effectiveness for overcoming problem moisture conditions varies. Table 11.5 presents published guidance (DOD, 2005) for various types of equipment and materials with recommended base lift thickness, typical passes or coverages, and equipment characteristics. This table provides initial guidance only; actual specification of the lift thickness or selection of equipment and passes is a function of the design requirements or construction conditions.

Experience and studies (Saxena et al., 1984) have shown that typical coarse refuse spread in lift thicknesses of one foot or less can usually be compacted to densities sufficient for embankment stability at impoundments. Normally, refuse for these applications is placed in one-foot-thick lifts and compacted to at least 95 percent of the maximum dry density at minus two to plus three percent of optimum moisture as determined from the Standard Proctor test, which is described in ASTM D 698,

TABLE 11.4 COMPACTION GUIDE FOR MATERIAL TYPES

Compactor Type	Soil			Weathered Rock-Earth, Ripped			Semisolid and Solid Rock, Blasted	
	Clays	Silts	Sands	Maximum Weathering	Average Weathering	Minimum Weathering	Well-Blasted	Poorly-Blasted
Sheepsfoot	Residual Soil							
Tamping Foot	Residual Soil							
Vibratory:								
Footed Drum								
Smooth Drum	Alluvial Soil							
Pneumatic Tires	Alluvial Soil							

(ADAPTED FROM CHURCH, 1981)

“Standard Test Methods for Laboratory Compaction Characteristics of Soil Using Standard Effort (12,400 ft-lbf/ft³ (600 kN-m/m³)).” In some cases, a more stringent compaction requirement may be necessary for impounding facilities depending upon the geotechnical characteristics of the embankment material. For instance, soils used as embankment fill will likely require a lift thickness of less than one foot to achieve the desired density.

The oversize correction provision of ASTM D 698 for material retained on the ¾-inch sieve should be followed, including the density and moisture content correction as per ASTM D 4718. If the correction is applicable, but is not applied, then the measured field density could overestimate the true compaction being achieved. As a result, while it might appear that the compaction specifications are being met, the actual degree of compaction could be less than specified, leading to problems with stability and seepage. In situations where there is a large percentage of oversize durable rock, such as sandstone, there can be a significant difference in the specific gravity, and laboratory measurements should be made of both the oversize and remaining material specific gravity (rather than adopting assumed values) when applying the correction. Application of ASTM D 698 may be difficult or may even be precluded when coarse refuse contains more than 25 to 30 percent of plus-¾-inch particles, based on application of the oversize correction provisions of the procedure. Sometimes the oversize correction yields unreasonable target densities (i.e., higher than achievable). In such cases other compaction test methods or field procedures should be considered. While use of the relative density test in accordance with ASTM D 4253, “Standard Test Methods for Maximum Index Density and Unit Weight of Soils Using a Vibratory Table,” and ASTM D 4254, “Standard Test Methods for Maximum Index Density and Unit Weight of Soils Using a Vibratory Table,” may be a possibility, this is generally not recommended because of the fine content in coal refuse.

Alternative material testing methods may be employed when more than 25 or 30 percent of plus-¾-inch particles are encountered. One such testing method is specified in Appendix VIA of the USACE Publication EM 1110-2-1906 titled “Laboratory Soils Testing” (USACE, 1986). This method employs a 12-inch-diameter mold that accommodates larger particle sizes. Disadvantages to this method are that it is more time consuming and costly than the ASTM D698 method, and many geotechnical laboratories are not equipped to perform the test. However, if refuse with a significant proportion of oversize particles is routinely generated, it may be desirable to use the USACE test to supplement or replace other methods.

Another possible method for compaction control is using a method specification such as the roller pass test, as described in WVDOT (1999) Standard MP-700.00.24. This procedure consists of preparing a roller pass test strip with fresh coarse refuse at the optimum moisture content. Compaction of fresh refuse is performed with the equipment that will be used during embankment construction (e.g., vibratory smooth-drum roller or similar or with loaded haul equipment), using sufficient passes (usually not more than 12) to compact the material without rutting or noticeable working surface deflection. Initial density tests are then performed. Additional compaction using two passes of the equipment is performed, and additional density testing is conducted to confirm that the maximum density has been achieved (i.e., the incremental difference in the average wet densities is less than one pound per cubic foot). In this case, the target maximum density and moisture content for compaction would be based on the roller pass maximum dry density.

To achieve the desired compaction and the desired geotechnical characteristics for a structural zone or embankment, the water content of the refuse must be controlled. This can be difficult during winter and inclement weather periods when there may not be sufficient space or time for drying or thawing wet or frozen materials. Embankment zones that may be designated for such conditions are discussed in [Section 11.5.3](#).

Typically, refuse piles and other non-impounding facilities can be designed with embankment zones placed in greater than one-foot lift thicknesses and/or can be compacted to a density lower than 95

TABLE 11.5 SUGGESTED COMPACTION EQUIPMENT AND METHODS

Equipment Type	Applicability	Typical Requirements for Compaction of 95 to 100 Percent of Standard Proctor Maximum Density			Possible Variations in Equipment	
		Compacted Lift Thickness (in)	Passes or Coverages	Dimensions and Weight of Equipment		
Sheepsfoot Rollers	For fine-grained soils or dirty coarse-grained soils with more than 20 percent passing No. 200 sieve. Not suitable for clean, coarse-grained soils. Particularly appropriate for compaction of impervious zone for earth dam or linings where bonding of lifts is important.	6	4 to 6 passes for fine-grained soil 6 to 8 passes for coarse-grained soil	Soil Type	Foot Contact Area (ft ²)	Foot Contact Pressures (psi)
				Fine-grained soil (PI > 30)	5 to 12	250 to 500
				Fine-grained soil (PI < 30)	7 to 14	200 to 400
				Coarse-grained soil	10 to 14	150 to 250
				Efficient compaction of soils wet of optimum requires less contact pressure than the same soils at lower moisture contents.		
Rubber Tire Roller	For clean, coarse-grained soils with 4 to 8 percent passing the No. 200 sieve. For fine-grained soils or well graded, dirty, coarse-grained soils with more than 8 percent passing the No. 200 sieve.	10	3 to 5 coverages 4 to 6 coverages	Tire inflation pressures of 35 to 130 psi for clean granular material for base course and subgrade compaction. Wheel load 18,000 to 25,000 lbs.		
				Tire inflation pressure in excess of 65 psi for fine-grained soils of high plasticity. For uniform clean sands or silty fine sands, use large-size tires with pressures of 40 to 50 psi.		
Smooth Wheel Rollers	Appropriate for subgrade or base course compaction of well-graded sand-gravel mixtures.	8 to 12	4 coverages	Tandem-type rollers for base course or subgrade compaction; 10- to 15-ton weight; 300 to 500 lb per lineal inch of rear roller width.		3-wheel rollers are obtainable in a wide range of sizes; 2-wheel tandem rollers are available in the range of 1 to 20 tons.

TABLE 11.5 SUGGESTED COMPACTION EQUIPMENT AND METHODS
(Continued)

Equipment Type	Applicability	Typical Requirements for Compaction of 95 to 100 Percent of Standard Proctor Maximum Density			Possible Variations in Equipment
		Compacted Lift Thickness (in)	Passes or Coverages	Dimensions and Weight of Equipment	
Smooth Wheel Rollers	May be used for fine-grained soils other than in earth dams. Not suitable for clean, well-graded sands or silty, uniform sands.	6 to 8	6 coverages	3-wheel roller for compaction of fine-grained soil; weights from 5 to 6 tons for materials of low plasticity to 10 tons for materials of high plasticity.	3-axle tandem rollers are generally used in the range of 10 to 20 tons weight. Very heavy rollers are used for proof rolling of subgrade or base course.
Vibrating Sheepfoot Rollers	For coarse-grained soils: sand-gravel mixtures	8 to 12	3 to 5	1 to 20 tons ballasted weight. Dynamic force up to 20 tons.	May have either fixed or variable cyclic frequency.
Vibrating Smooth Drum Rollers	For coarse-grained soils: sand-gravel mixtures – rock fills	6 to 12 (soil) to 36 (rock)	3 to 5 4 to 6		
Vibrating Baseplate Compactors	For coarse-grained soils with less than about 12 percent passing No. 200 sieve. Best suited for materials with 4 to 8 percent passing No. 200 sieve, placed thoroughly wet.	8 to 10	3 coverages	Single pads or plates should weigh no less than 200 lb. May be used in tandem where working space is available. For clean coarse-grained soil, vibration frequency should be no less than 1,600 cycles per minute.	Vibrating pads or plates are available, hand-propelled, single or in gangs with width of coverage from 1-½ to 15 ft. Various types of vibrating-drum equipment should be considered for compaction in large areas.
Crawler Tractor	Best suited for coarse-grained soils with less than 4 to 8 percent passing No. 200 sieve, placed thoroughly wet.	6 to 10	3 to 4 coverages	Vehicle with "standard" tracks having contact pressure not less than 10 psi.	Tractor weight up to 85 tons.
Power Tamper or Rammer	For difficult access and trench backfill. Suitable for all inorganic soils.	4 to 6 for silt or clay; 6 for coarse-grained soils	2 coverages	Minimum weight 30 lb. Considerable range is tolerable, depending on materials and conditions.	Weights up to 250 lbs, foot diameter 4 to 10 in.

(ADAPTED FROM DOD, 2005)

percent of the maximum dry density. For a refuse pile, MSHA regulations do not permit lift thicknesses in excess of 2 feet unless an adequate factor of safety has been demonstrated. However, lift thicknesses of two feet (or greater) may preclude uniform compaction. From a technical standpoint, coarse refuse at non-impounding facilities that contains predominantly large particles similar to rock fill can be placed and compacted in larger lifts, if adequately-sized compaction equipment is used. Since coarse coal refuse typically consists of both rock and soil particles, one to two-foot lifts can typically be used if suitable compaction equipment is employed.

Appropriately-sized equipment does not guarantee that placement and compaction of refuse will be as desired. The coordination of equipment operations and sequencing of refuse placement greatly affects the level and quality of compaction achieved. Refuse should be placed in piles on the working surface and spaced so as to allow spreading equipment to achieve the specified lift thickness with minimal effort prior to compaction. Refuse should be spread away from a conveyor discharge point to the specified lift thickness. A sequence or progression of refuse placement should be established. When handling equipment of sufficient number and size is employed using an efficient operating system, refuse should be evenly distributed on the working surface and can be spread in relatively thin horizontal lifts, allowing compaction equipment to perform under favorable conditions.

To achieve consistent and uniform compaction, successive lifts should be knitted together by scarifying smooth compacted surfaces prior to placement of subsequent lifts. This is particularly important where concentrated haul traffic has resulted in additional breakdown of the material or where smooth-drum rollers are used. Generally, little scarifying is necessary where padded or sheepsfoot rollers are employed unless the working surface has been dormant for a long period of time or where concentrated haul traffic has occurred. A rock ripping attachment for a tractor dozer may be required to scarify the working surface properly.

Where an intermediate crest elevation has existed for a period of time, the surface may become highly compacted from the combination of traffic and breakdown of the surface material due to weathering. Additionally, freezing conditions can result in frost heave and formation of ice lenses. If this condition is not addressed when the next lift is placed, then a layer of differing hydraulic conductivity may cause seepage to run horizontally and exit at the face of the downstream slope. Such a condition, which will lead to concerns about seepage and stability, can be addressed by scarifying or removing the top surface material prior to placing the next lift.

Special care must be taken to achieve adequate compaction at the sloped edges of each lift where, due to the lack of natural confinement, the refuse tends to move away from the equipment without densification. Although the total stability of an embankment is not significantly affected by refuse density at the slope face, loose material is susceptible to erosion and creep. To achieve adequate surface density, compaction should extend several feet down the slope. If this is not possible, the loose material should be shaved off with a dozer or excavator and pushed back onto the working surface for compaction.

When structural fill is placed against a hillside or against an existing embankment, the existing material should be keyed or benched. This can be accomplished by using a dozer to cut a sufficient distance into the slope (e.g., approximately three or four feet horizontally where the terrain is steep) as the new refuse embankment is advanced in height. [Figure 11.3](#) illustrates the process of benching to tie structural fill into a natural slope. This process removes surface material that may not be at the required density, permits compaction at the construction interface, and reduces the tendency for a natural slip surface to develop at this critical location.

Compaction tests, as discussed in [Section 11.8](#), should be performed relatively often during initial structural fill refuse construction when material characteristics and equipment efficiency are being

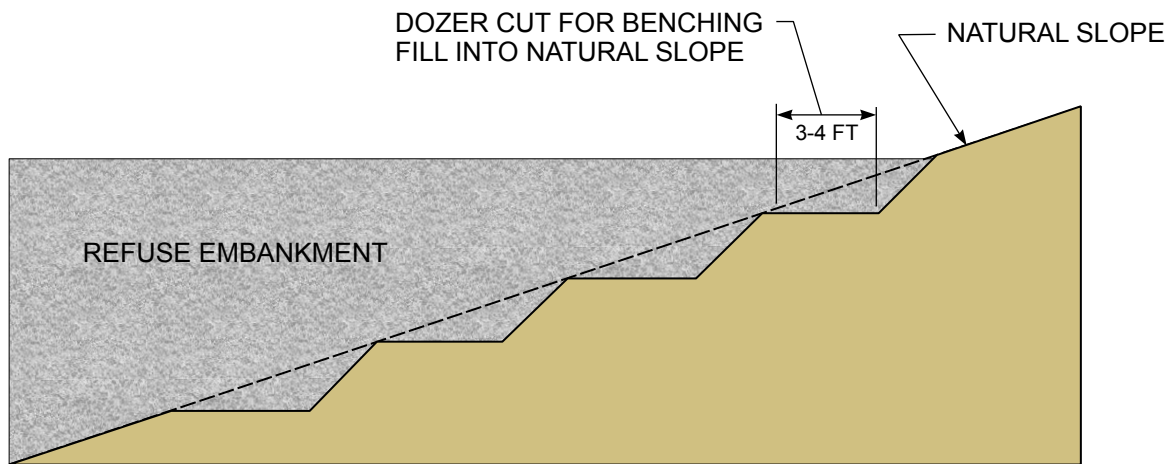

FIGURE 11.3 BENCHING OF EMBANKMENT FILL INTO NATURAL SLOPE

evaluated. Thereafter, the testing frequency can be reduced, provided that a history of successful equipment performance and density testing indicates that the desired compaction is being accomplished. A typical criterion for the frequency of compaction testing for embankment fill is: at least one density test per 2,000 cubic yards of material placed or one test for every lift placed, whichever is greater (USBR, 1998). Tests should also be performed when it is suspected that adequate compaction is not being achieved.

11.5.2 Upstream Construction Implementation Procedure

Incidents have occurred while establishing pushouts where bulldozers have sunk into the underlying fines and not been recovered. Even in situations where the fine refuse surface is dry, desiccated and vegetated, the underlying materials may remain soft and can exhibit sudden shear failure under equipment operation.

As indicated previously, upstream construction of an impounding embankment poses technical and construction challenges. Since upstream construction involves the development of an embankment over saturated, unconsolidated fine coal refuse, the stability of the embankment under both static and dynamic loading must be carefully evaluated. The potential for sudden failure of the pushout surface and the underlying fine refuse during upstream construction requires that special techniques and equipment be used and that the work be performed by experienced and properly trained equipment operators.

Placement of material on top of saturated, hydraulically-placed fine coal refuse results in the compression of fine materials. Since the material is initially loose and saturated, as the particles move to a closer packing, the water in the pores is placed under pressure. This excess pore-water pressure reduces the effective stress and can make the material unstable. Fill material must be placed on top of the fines at a slow enough rate that the pore-water pressure can dissipate without causing significant instability. If too thick a layer is placed too quickly, instability will occur that can adversely affect both the immediate safety of the equipment operators and the overall safety of the embankment.

It is important that equipment operators understand the potential for instability during upstream construction and the general concept that the rate of material placement during upstream construction must be controlled. Placing material thicker and/or faster on hydraulically-placed fines can be detrimental. When excess pore-water pressures are created in one area, construction activity should be moved to another area to allow pore-water pressures to dissipate.

Task-specific training should be provided to the equipment operators that will be performing upstream pushout embankment construction and to workers who will be in the vicinity of the

upstream construction. The training should familiarize operators and workers with the risks associated with upstream construction and should include specific instructions for developing access to pushout areas, along with specific construction methods for performing upstream construction. Information describing the risks associated with upstream construction and features that are indicative of unstable working surfaces should be provided as part of the training program. Records documenting the training should be kept.

Certain precautions are essential for minimizing the potential for failure of coarse coal refuse placed over fine refuse. These precautions will also help to minimize the potential for occurrence of accidents associated with the upstream construction activities. These precautions include the following:

- Impoundment construction and discharge of fine refuse should be managed such that a sufficient fine refuse delta on which to initiate upstream construction is created. The delta should be as uniform as is practical, which can be facilitated by routinely moving the slurry discharge point along the upstream slope of the embankment.
- The normal pool elevation should be lowered via pumping or other means (if practical) to the lowest practical level and away from the fines delta.
- A buffer should be established from the edge of proposed pushout where high-ground-pressure vehicles such as haul trucks are excluded from travel. The width of the buffer should be established based on site-specific conditions and equipment (e.g., 50 feet has been satisfactorily used).
- Only low-ground-pressure equipment should be used to perform upstream construction within the buffer area.
- Two-way radio communication for equipment operators and mine personnel should be provided during upstream construction activities, and it is recommended that equipment operations during the initial pushout be within sight of mine personnel and that operators be provided with floatation devices (e.g., life jackets).
- Work should only be performed during daylight hours until a stable working surface is established.
- The placement of coarse refuse for upstream construction should initiate with advancement of a thick layer (typically 4 to 6 feet thick) of coarse coal refuse onto the exposed fine refuse delta. Placement of the initial lift of coarse refuse should begin along the embankment upstream slope and gradually advance upstream over the fine refuse. A portion of the advancing lift may sink into the fine refuse in soft areas or areas where the surface is saturated. It may be possible to minimize this effect by reducing the lift thickness or lowering the impoundment water level.
- Equipment working near the upstream edge of the pushout should be oriented perpendicular to the face of the active edge (i.e., no equipment should travel near and parallel to the upstream edge of the pushout).
- Pushout construction should be sequenced so that haul trucks do not travel adjacent to pushout areas until a stable working surface is established.
- Pushouts should be constructed utilizing a buffer consisting of at least one pile of coarse refuse. The buffer pile of coarse refuse should remain between the dozer and impoundment as the refuse is pushed onto the fine refuse delta. Use of this method will always keep the dozer in a safer position away from the edge of the fine refuse.
- Pushouts should be performed perpendicular to the upstream face of the embankment and/or impoundment and should be limited to a prescribed length onto the delta (e.g., 25 feet measured from the upstream edge of the embankment or stable working surface). It is recommended that the initial lift for upstream construction be

spread to a width of at least two times the push out length (e.g., 2 times 25 feet or 50 feet) before further advance of the lift upstream over the delta.

- The surface of the upstream pushout embankment should be graded to drain toward the impoundment.

Monitoring and inspection of the upstream construction area should be performed by a qualified person who is familiar with upstream construction methods and risks. Prior to and during initial pushout construction, this person should inspect the refuse embankment and the area of the upstream construction. The inspection should focus on identifying conditions that could affect the safety of the equipment operators as well as conditions that could affect the safety of the embankment. These include the following conditions:

- Development of cracks with vertical displacement or scarps in the vicinity of the pushout (the orientation and shape of the cracks may indicate shearing rather than differential settlement)
- Excessive pumping of the pushout surface
- Excessive bulging of the fine refuse delta (e.g., bulge or displacement height in excess of the pushout lift level) where work is being performed
- A situation posing a threat that the embankment could be overtopped by water or slurry
- Sudden or major subsidence of the embankment crest
- Longitudinal or transverse cracking of the embankment crest
- Major sliding/failure of upstream or downstream embankment slopes or abutment slopes adjacent to the embankments
- Unusual seepage from areas of the downstream face or from the toe of the embankment
- Unusual conditions on the embankment downstream slopes that develop during upstream construction
- Significant landslides within the impoundment area

In addition to the above conditions, embankment piezometers should be monitored before and during the upstream construction. Where development of significant pore pressures are or remain a concern for the initial pushout, new piezometers can be installed within the fine refuse to aid in monitoring of the upstream construction process. The location for piezometers should reflect the potential interference from construction activities and the likely displacements associated with upstream construction.

If any of the above listed conditions are observed, or if piezometers indicate unacceptable levels of pore pressure, the information should be reported to the Engineer and Operator, and equipment and personnel should be moved to another work area until the cause of the problem is identified and corrected. The results of the inspection should be documented.

11.5.3 Excess Coarse Refuse/Inclement Weather Disposal

Some coal preparation plants may generate more coarse refuse than required for impounding embankment construction (excess coarse refuse), with the result that specific embankment zones or separate embankments are designed with different material placement and compaction criteria (e.g., thicker lifts). This situation may also result in the designation of a location for inclement weather disposal, when compaction to the normal embankment specifications is precluded due to moisture or freezing conditions.

To mitigate concerns for combustion, excess coarse refuse should generally be spread in layers or lifts less than 2 feet thick. Additionally, lift placement should result in a working surface capable

of supporting equipment traffic associated with subsequent disposal operations. Other geotechnical factors that must be considered before constructing embankment zones with thick lifts include settlement and hydraulic conductivity.

Placement of refuse in thick lifts may also be acceptable at non-impounding embankments and in surface mine backstack areas where such materials do not influence the stability and drainage control of the site. Note that 30 CFR § 77.215 addresses construction requirements for refuse piles. Section 77.215(h) requires that refuse piles be constructed in compacted layers not exceeding 2 feet in thickness except that the MSHA District Manager may approve construction of a refuse pile in compacted layers exceeding 2 feet in thickness where engineering data substantiate that a minimum static safety factor of 1.5 will be attained.

Sealing of any disposal surface that will be exposed for a long period of time is always important. Sealing requires use of smooth-wheeled vehicles (hauling units or smooth-drummed compaction equipment) rather than tamping-foot rollers, with appropriate grades provided for drainage. For final surfaces, preparation for abandonment and revegetation should follow procedures discussed in Chapter 10.

11.5.4 Disposal of Fine Refuse Slurry

The fine coal refuse slurry disposal system is a distinct part of a coal refuse disposal facility. Slurry pipe size, composition, anchor/bracing details, discharge point locations and construction methods should be included in facility plans and specifications for implementation as part of overall refuse disposal operations. Disposal of fine coal refuse slurry is discussed here with respect to site-related planning, scheduling and the relationship to other construction and disposal operations. If possible, the disposal of fine refuse slurry should result in a fine coal refuse delta above the impoundment pool to: (1) provide the best possible foundation for upstream advancement of the embankment whether or not the facility is initially planned to be developed by the upstream construction method, (2) protect the embankment face from wave erosion by minimizing the impounded water depth at the upstream embankment slope, and (3) reduce seepage into the embankment and keep the phreatic surface associated with embankment seepage as low as possible (assuming the fine coal refuse hydraulic conductivity is lower than the embankment hydraulic conductivity). At some facilities clarified water from the impoundment is pumped to a separate cell, typically at the upstream end of the reservoir, further isolating the pool from the embankment face.

As illustrated in [Figure 11.4](#), slurry disposal functions most effectively if the discharge point of the transport pipe is located at a relatively low elevation on the impoundment side (upstream slope) of the embankment and is periodically moved to adjacent locations along the upstream slope. The coarsest material in the slurry will be deposited in the immediate vicinity of the discharge point, leading to maximum material strength near the embankment and maximum water depth near the upstream end of the impoundment. Periodic movement of the discharge point back and forth along the upstream edge of the embankment will create a more uniform delta deposit. The slurry may be discharged at other locations to achieve slurry deposition at specific features such as mine barriers or to more fully utilize available impoundment capacity. The refuse disposal plan should discuss the type and size of equipment required to move the slurry discharge pipe around the impoundment.

Pipes transporting the slurry to the impoundment should not be placed through the embankment unless seepage and structural provisions are provided. Pipes through embankments tend to be natural paths for seepage and could result in embankment failure from internal erosion. Also, pipes installed within the embankment or along the downstream face of the embankment could cause erosion and are an environmental hazard if they leak or fail ([Figure 11.4a](#)).

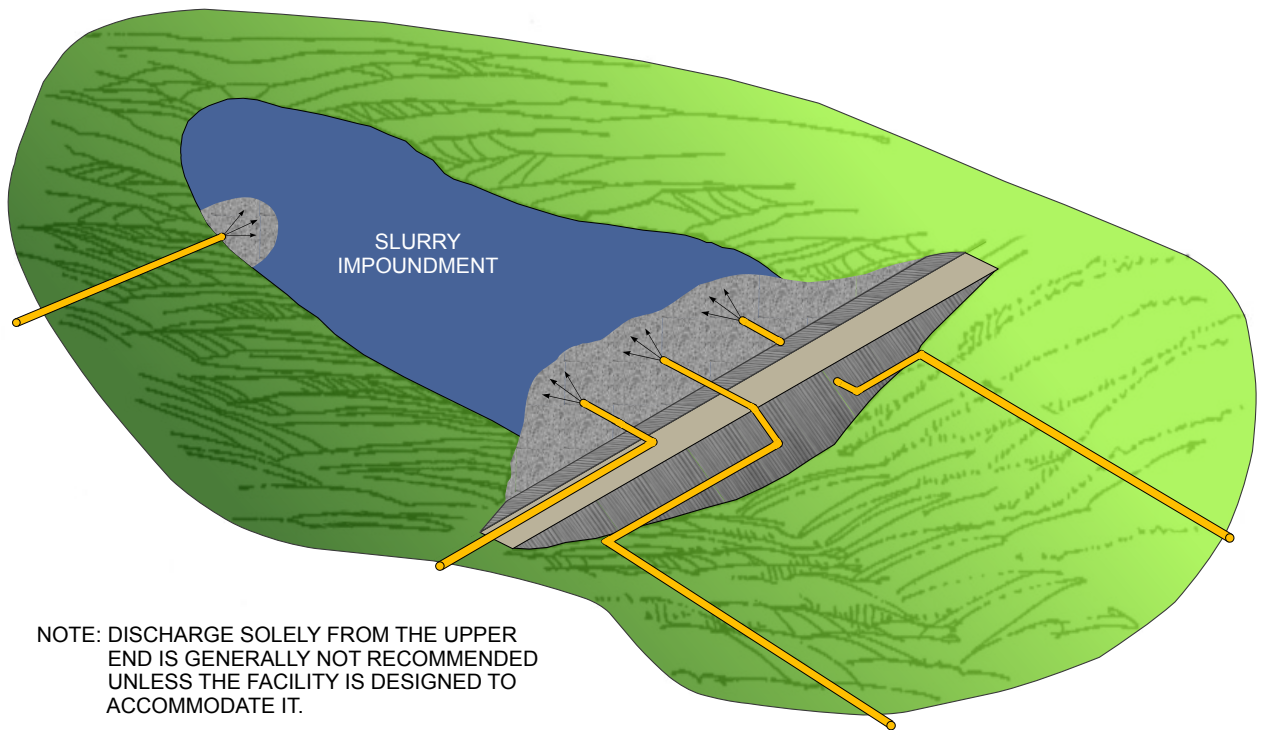

11.4a INCORRECT SLURRY PIPE INSTALLATION

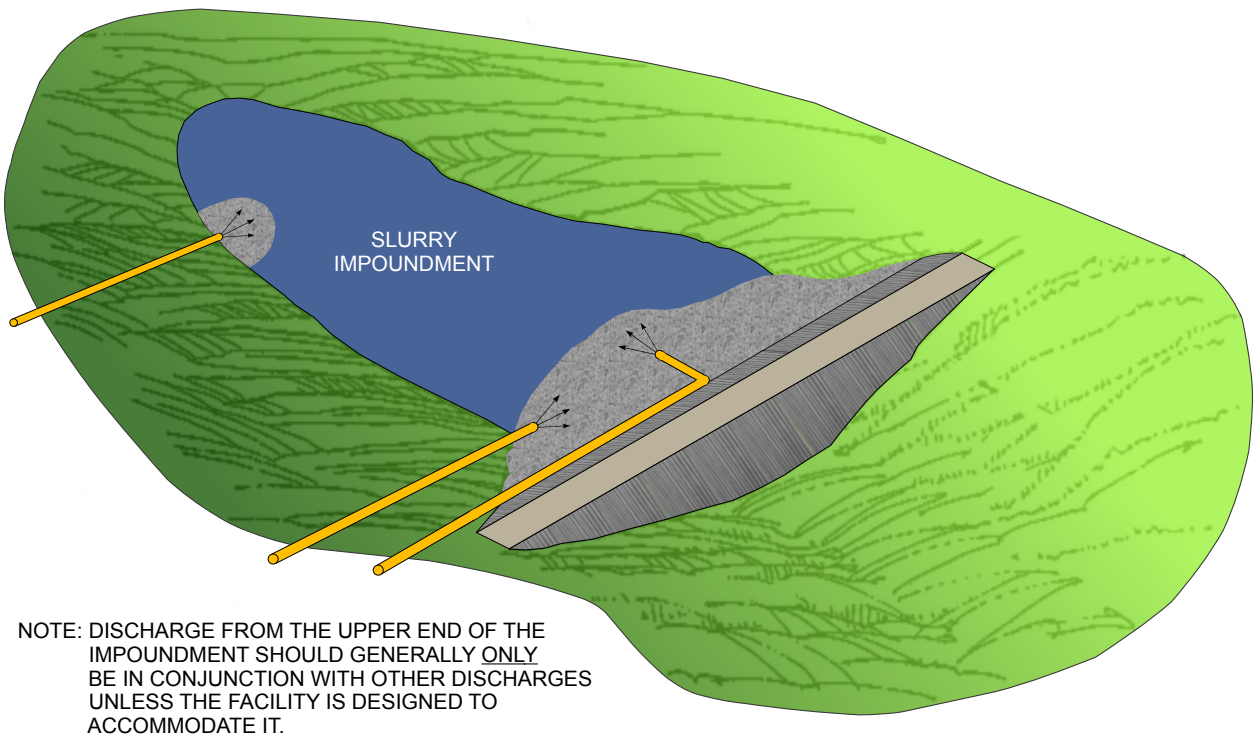

11.4b CORRECT SLURRY PIPE INSTALLATION

FIGURE 11.4 SLURRY DISPOSAL

11.5.5 Disposal of Combined Refuse

As discussed in Chapter 2, fine coal refuse slurry can be processed by dewatering with a vacuum filter, belt filter press or centrifuge. A filter cake of fines that in some instances is at a water content too high for easy transport and disposal as a solid waste material can result, particularly during inclement weather periods. Under such adverse conditions, the filter cake may be difficult to confine in haulage units. To minimize spillage and resulting degradation of haul roads, conventional trucks fitted with sealing tailgates may be necessary. As a separate waste material, filter cake typically can't be spread in lifts and compacted and will not support construction equipment.

To resolve this materials transport and disposal problem, the filter cake can be mixed with coarse refuse at the preparation plant, resulting in a combined refuse that normally can be transported in conventional trucks or by conveyor. However, watertightness of transport unit bodies is desirable, because the material is typically very wet.

Combined refuse disposal facilities are typically designed as non-impounding embankments or refuse piles. In some instances where the combined refuse is very wet, the material may not be suitable for normal embankment construction. A large area may be needed for spreading and drying the material. During wet or winter periods, movement of spreading or compacting equipment over this area may be difficult or impossible. This can lead to operational inefficiencies and larger disposal areas than normally required. If confined disposal is necessary, a structural zone or embankment may be needed for retaining the combined refuse. Such embankments must be constructed from borrowed soil and rock materials, or some of the coarse refuse must be diverted for this purpose.

The mine operator or designer should carefully evaluate the effects of combined refuse disposal prior to implementation of this type of total disposal system so that all relevant requirements and limitations are factored into the planning. The procedure for disposing of coarse refuse and dewatered fine refuse filter cake must be planned and designed specifically for conditions found at the disposal site.

11.5.6 Use of Amendments

Coal refuse may require amendments for neutralization and stabilization. The relative quantities and methods for combining refuse and materials such as lime, combustion ash, and kiln dust should be detailed in the facility plans, specifications and the operation and maintenance plan. Rich and Hutchinson (1990) discuss the operational implications of using lime kiln dust to neutralize and stabilize combined refuse at a West Virginia mine site using the following practices: (1) mixing the kiln dust with filter cake at the preparation plant to absorb moisture, (2) refuse cell development with elevated roadways constructed with rock for equipment access for dumping of the combined refuse, and (3) methods to shed excess water by separating the dumped piles to allow drainage prior to grading, and (4) maintaining drainage control within the refuse cell. For the cited case, an application of 2 percent by weight of kiln dust provided sufficient improvement in the combined refuse to enable effective disposal. [Section 10.3.2.3](#) provides additional discussion of amendments.

11.6 RELATED ACTIVITIES

Many activities besides refuse disposal are involved in the development of a disposal facility. Activities associated with coal refuse disposal include:

- Construction and maintenance of haul or access roads
- Construction of liner systems prior to refuse placement
- Development of underdrain and spring collection systems

- Foundation preparation prior to disposal of coal refuse
- Placement of earth borrow material as structural fill and impervious cores and/or seepage control blankets
- Control of water while constructing facility appurtenances and developing the embankment foundation
- Construction of internal drainage systems within the embankment
- Excavation for spillways, ditches, drainage installations, repair work, etc.
- Construction of embankments for mine seals and barriers (e.g., fills for protecting impoundments from the influence of potential underground mine subsidence)

In general, construction procedures for these related activities are the same in mining as for heavy construction. Therefore, discussion of these topics herein is limited and is related specifically to coal refuse disposal operations.

The activities listed above and the construction of appurtenant structures subsequently discussed in [Section 11.7](#) are similar in the sense that neither pertain directly to the primary facility purpose of refuse disposal, yet both are needed for refuse disposal to proceed. The distinction made herein is: (1) the above activities will generally be performed with the same equipment used for refuse disposal, and the materials required are basically available at the site, and (2) the structures discussed in [Section 11.7](#) generally require special equipment and procedures, and the materials involved must be purchased.

11.6.1 Haul and Access Road Construction and Maintenance

Haul and access roads are an integral part of a site refuse transport system and have been a source of safety concerns. Surfacing, width, signage, runaway vehicle provisions, drainage control and berms are important design issues. Roadway layout, design and maintenance impacts the operations of the refuse disposal facility. Haul and access road locations must be determined in the initial stages of planning and design of the refuse disposal facility. Consideration must also be given to temporary haul roads required during various stages of facility construction for safe access to the working surface of the embankment. Because of the importance of disposal facility haul roads, MSHA (1999) published *The Haul Road Inspection Handbook*, which focuses on the safety aspects of haul road design. Guidance for the layout and design of haul and access roads is also provided in the U.S. Bureau of Mines publication, *Design of Surface Mine Haulage Roads – A Manual* (Kaufman and Ault, 1977), and other references.

11.6.2 Liner Systems

State regulations require protection of the groundwater. This may in some states necessitate the installation of a liner system to reduce the potential for impacts to the environment. The extent and type of liner system required for groundwater protection generally depends upon the environmental setting of the refuse disposal site and the potential acidity of the refuse. Liner systems are normally constructed of clay soils from on-site borrow areas or from geosynthetic materials. Geosynthetic liners may consist of a geomembrane or a clay-impregnated geotextile (geosynthetic clay liner or GCL). Clay soil liners are used when the acid potential of the refuse is low to moderate, and geosynthetic clay liners may be considered for higher acid potential refuse or when clay is unavailable at the site. Liner systems are normally installed after foundation preparations have taken place and prior to the placement of refuse. Extensive underdrain and spring collection systems are sometimes installed beneath liner systems to prevent sloughing and/or slides that could compromise liner integrity. Because of the potential for a liner to introduce a slip plane, the effect of a liner system must be evaluated in the stability analyses. [Section 10.4](#) provides additional discussion of liner systems.

11.6.3 Embankment Foundation Preparation

As discussed in [Section 6.3](#), the foundation of a coal refuse embankment will affect embankment stability, settlement and seepage. To achieve stability or to minimize potential settlement, removal of soft cohesive materials may be desirable. However, for seepage and leachate control, these materials can provide an effective seal if left in place. Thus, cost-effective foundation design for a disposal facility embankment requires that important decisions be made relative to removal or use of on-site materials.

11.6.3.1 Clearing and Topsoil Stockpiling

Cutting and removal of trees, brush and other vegetation within the footprint of the embankment should be specified. Vegetative matter, if not removed, can decay and cause settlement and the formation of slip planes. Vegetative matter may also contribute to spontaneous combustion and burning. Additionally, floating trees and branches can plug hydraulic structures, particularly culverts and decants. Cleared material should be removed from the construction area or burned.

Topsoil present in areas where refuse will be placed should be removed and stockpiled for reclamation. Stockpiling should be performed in a controlled fashion in areas away from natural drainage courses and areas of planned future development. State mining regulations typically provide guidance for topsoil removal and stockpile requirements.

Within impoundment areas, trees and heavy brush should be cleared and removed so that floating debris that could impact operation of spillways and decants is not present. Soil and topsoil should be stockpiled for future use, as required. Clearing and removal of soils within the impoundment area should be sequenced so as to minimize excessive disturbance to hillsides that could cause erosion and lead to potential slope instabilities. Typically, clearing should be limited to areas that will potentially be affected by the impoundment within one or two years.

11.6.3.2 Soft Soil Foundations

An effort should be made during the geotechnical subsurface exploration program to identify soft soil foundation areas. If soft soils are present where a refuse embankment is planned, removal of the soft materials may be necessary. Such removal can generally be accomplished with normal excavating and hauling equipment. Temporary access roads for construction equipment should be constructed as needed to facilitate safe operations. Depressions associated with removal of soft soils can be back-filled with either on-site borrow material or coarse refuse, as available. Some types of soft soils may be suitable for clay liner construction or for use as final reclamation cover, in which case they should be stockpiled on the site and reused.

11.6.3.3 Competent Soil Foundations

If generally competent foundation materials are present in the area where embankment construction is planned, it may be possible to utilize these in-situ materials. Some over-excavation and recompaction of the material may be required if the soil type is acceptable but the in-situ density is too low. Prior to such work, the area should be cleared of vegetation and organic topsoil. Clearing and excavation/recompaction should not be performed very far in advance of refuse disposal since prolonged exposure of the foundation soil could lead to weathering and deterioration of important physical properties and/or cause environmental damage. Construction of temporary access roads and stockpiling of topsoil or other recoverable material should be performed in the manner previously described.

11.6.3.4 Rock Foundations

From the standpoint of strength, rock is usually an adequate foundation material for a coal refuse embankment. However, an evaluation of foundation rock conditions should be performed, since trou-

blesome layering or discontinuities and localized weaknesses may be present. Seepage and uncontrolled discharge of leachates through fractures in foundation or abutment rock can be a significant problem, especially for impounding facilities. [Sections 6.6.5](#) and [8.9](#) discuss methods for preparing rock foundations and abutments for construction of embankments.

Not all rock characteristics may be apparent following the geotechnical exploratory drilling and laboratory testing performed as part of facility design. Thus, it is highly desirable that the foundation surface be inspected by a geologist or geotechnical engineer after the foundation has been exposed by excavation. This will allow final confirmation of the embankment design prior to construction. If special provisions associated with rock foundations are needed, they will typically involve control features such as impervious soil blankets, localized grouting, shotcrete placement, or preparation of a planned contact between clayey soils and rock. [Section 11.6.6.1](#) discusses the placement of impervious blankets. Foundation grouting of rock formations to cut off or minimize seepage through fractures is discussed in Fell et al. (2005) and USACE (1984a).

11.6.3.5 Mine Spoil

Mine spoil may be present in the foundation of the area planned for coal refuse disposal, either as remnant materials from past mine operations at the site or as a result of planned surface mining and refuse disposal. Evaluation of the mine spoil characteristics and associated foundation preparation requirements should be addressed in the refuse disposal facility design. Characterization of the mine spoil properties and the potential for use of mine spoil in construction along with the possible need for removal, densification, and seepage/internal erosion control should also be addressed. [Section 8.8](#) presents design and construction considerations associated with mine spoil. State regulations may limit the use of mine spoil at a refuse disposal facility.

If unanticipated spoil materials are encountered, they should be thoroughly characterized to determine if they are suitable for incorporation into the foundation at an impounding coal refuse disposal facility.

11.6.4 Water Control

Control of water in relation to the development of coal refuse disposal facilities falls into four basic categories:

1. Control of flood water by storage capacity combined with spillway and decant structures for impoundments and by diversion ditches for non-impounding embankments
2. Control of seepage through and under the refuse embankment (from springs/groundwater and from impounded water)
3. Control of natural stream flow and storm runoff during construction when permanent facility hydraulic structures are not completed
4. Control of site drainage from storm runoff

The first category of water control structures refers to hydraulic structures associated with conveying watershed runoff through or around the coal refuse disposal facility. Design requirements for these structures are presented in [Section 9.7](#), and construction requirements for these features are discussed in [Section 11.7](#).

The second category of water control structures refers to internal drains for collection and control of springs in the foundation area, seepage from an impoundment, interception of leachates, and control of the phreatic level in the embankment. Design requirements for filters and drains are presented in [Section 6.6.2.3.1](#), and construction requirements are discussed in [Section 11.7](#).

The third category of water control is often referred to as a “diversion” and may be required during facility construction. A diversion can be as simple as installing a small drainage culvert under a haul road or as complex as construction for passing a stream around a site prior to completion of permanent facility hydraulic structures. For coal refuse disposal, diversions may be required on several occasions during the operational period of the facility as, for example, the perimeter ditch system at a valley fill is upgraded to match the advancing refuse embankment. Temporary diversions should be designed and constructed consistent with the risk associated with failure during the time of use (i.e., the shorter the period of time required for diversion, the smaller the design storm requirement, consistent with regulatory requirements). Permanent diversion ditches should be designed as long-term drainage channels. Typical design criteria for stream diversions are presented in Chapter 9.

Diversion requirements discussed in Chapter 9 include:

- Inlet and outlet sections sized to handle expected flows and designed without obstructions or sharp angles
- Transport section alignment and grade
- Freeboard design for preventing overflow to areas that must be protected
- Design for prevention of erosive damage through material selection and energy dissipation control

Planning, scheduling and construction of diversions should reflect requirements for continued refuse disposal and other site related activities. Access across open diversions may be difficult, especially where permanent stream flows are being conveyed. Light-gauge, temporary culverts may be capable of passing the required flow. However, heavy equipment passing over such culverts can cause damage if they are inadequately designed and constructed.

Although material selection for temporary diversions is not as important as for permanent hydraulic structures, strength, erosion and corrosion issues must be considered. Further discussion of these topics is provided in [Section 9.7.3](#) and [Section 11.7](#).

The fourth category associated with water control is related to on-site drainage for handling storm runoff. This type of water control generally includes grading of embankment surfaces and construction of conveyance and collection structures. Temporary and final embankment surfaces, including the active work area for refuse placement, must be graded such that runoff is directed toward conveyance channels and that ponding and saturation of the fill is minimized. This is typically accomplished by specifying surface grades of at least 1 percent and controlling the placement of lifts so as to maintain a positive gradient toward the perimeter of the embankment where the runoff is collected and conveyed from the area in channels. The channels then convey site runoff to sedimentation traps or ponds for clarification before release. These drainage control features should be incorporated into the facility plans and specifications. The design of site drainage structures is addressed in Chapter 9.

A critical element in control of on-site drainage is the actual process of coarse refuse placement. Lift placement (typically end-dumped piles placed by trucks) and spreading to a uniform thickness for compaction is dependent upon a working surface that can support construction traffic and is not excessively wet or does not have standing water that would interfere with the compaction effort. If each lift is advanced uniformly across the entire active working surface, the surface gradient to drainage channels is maintained. Also, when periods of sustained inclement weather occur that adversely impact the working surface, it is useful to grade and seal the working surface so that it sheds water and to have other non-critical areas for short-term disposal.

Mobile conveyor systems are sometimes employed to deliver coarse refuse directly to the working surface, with dozers, loaders and trucks used to spread the lift materials. Mobile conveyor locations and equipment selection should reflect the need for advancing lifts uniformly across the working surface to maintain the drainage gradient.

11.6.5 General Excavation

Excavation is required for construction of diversions, minor drainage ditches and channels, trenches for internal drains and control of natural springs, major decants or spillways, embankment foundation development, liner construction, haul and access road construction, and other site operations. Many of these earth-moving activities have already been discussed. However, certain precautions should be taken for excavations at coal refuse disposal sites.

Many coal refuse disposal facilities are located in mountainous areas. It follows that some excavations associated with facility development at these sites will result in steep, side-hill cuts. In making such excavations, care should be taken to disturb as little vegetation as possible, particularly on the uphill side of drainage ditches. This is especially important if the cut being made is for the construction of a permanent drainage channel. The stability of slopes above drainage channels is crucial to their performance during storms. Vegetation, especially in the form of trees with extensive root systems, helps to maintain slope stability of steep natural hillsides and also aids in minimizing the potential for erosive movement of soil into the channel and consequent blocking or reduction of flow capacity.

Stability of excavated slopes, whether the excavation is permanent or temporary, can be achieved by decreasing the angle of the cut or by bracing the exposed surface. Only if excavations are in sound, competent rock should vertical cuts be made. Steeply-sloped excavations in clayey soils may appear stable at the time of excavation, but sudden collapse, especially during rainy weather, can occur. Safety regulations such as those developed by OSHA for providing safe conditions in and around open excavations should be strictly followed. Slope stability issues are discussed in more detail in [Section 6.6.4](#).

11.6.6 Embankment Fill Constructed from On-Site Borrow Materials

Starter embankments for impounding facilities are frequently constructed from on-site borrow materials. At some coal refuse disposal facilities, coarse coal refuse may not be available in sufficient quantities or with adequate properties for all embankment fill requirements. Combined coarse and fine refuse may be difficult to compact to the density and strength required for structural fill. Also, as discussed in Chapter 6, an impervious earth core or cutoff may be needed within the refuse embankment or as an upstream blanket for controlling seepage and water pressure. These considerations may necessitate construction of a zoned embankment with design implications as discussed in [Sections 5.1](#) and [6.3.1.2](#). Borrow materials may also be needed for fills and embankments associated with mine seals and barriers. For any of these situations, use of on-site sources may be necessary. While borrow materials generally can be characterized as “clayey and silty” or “rock and granular,” mine spoil materials may exhibit both types of characteristics.

11.6.6.1 Clayey and Silty Borrow Materials

If fine-grained borrow materials such as clays or silts are to be placed in zones as part of embankments or for seepage control (impervious blankets and cores), major considerations during construction include:

- Material properties such as grain-size distribution, water content, densities, strength, hydraulic conductivity, etc.

- Material availability in sufficient quantities, preferably located near the construction site
- Equipment required for loading, transporting and placing the material
- Lift thickness during placement
- Equipment required for compaction and appropriate compaction procedures

Detailed discussions of earth-fill operations can be found in Sherard et al. (1963), Church (1981), USACE (1995b) and USBR (1998). Some general comments regarding the distribution and placement of clayey and silty borrow materials (for structural fill and impervious blankets and cores) are:

- The material may be difficult to remove from the borrow areas. If scrapers are used to excavate earth borrow of this type, an additional tractor may be required.
- The material should be placed in relatively thin lifts. Sherard et al. (1963) recommended approximately 6 to 9 inches. If thicker lifts are used, the required density may not be achieved throughout the full depth of the lift.
- Compaction equipment used for clayey or silty soils is typically of the segmented-pad or tamping-foot type, commonly referred to as a sheepsfoot roller. Vibration does not significantly improve the compaction of these soils.
- The compactability of clayey and silty soil is very sensitive to moisture conditions. In most regions, borrow areas should be graded to shed surface water, and fill areas should be sloped to drain. In dry regions, moisture may have to be added to the borrow material. Sealing of fill areas by rolling with smooth-wheeled vehicles or non-vibrating, smooth-drum rollers is recommended if precipitation is anticipated. USBR (1998) and Church (1981) provide discussions of embankment construction and moisture control.
- If the borrow material water content is too high to permit adequate compaction, drying may be required. Drying can sometimes be accomplished by disking and allowing the sun and wind to remove the moisture.
- Placement and compaction of fill for impervious blankets and cores in winter weather is always difficult and is essentially impossible if the soil is frozen. Operations should be scheduled to avoid fill placement during periods of adverse weather conditions.

The above discussion relates primarily to embankment zones where strength is a major factor. If borrow material is being used for seepage control such as an impervious core within the embankment or an impervious blanket in the valley bottom, it is essential to obtain a uniform, non-layered clayey or silty soil consistency. In such applications, the borrow material should be placed a few percentage points wetter than optimum water content if the material can meet the associated strength requirements and is in accordance with the construction specifications. This should result in a homogeneous mass flexible enough to accept deformation without cracking. Further discussion of this subject is provided in [Section 6.5.3](#).

11.6.6.2 Rock and Granular Borrow Materials

Many considerations for use of rock or granular borrow material for structural fill are similar to those mentioned above for clayey or silty borrow material. However, the handling and compaction equipment needed, acceptable lift thicknesses, and material properties are different.

Rock-fill material is generally handled by large excavators and haul trucks, and granular borrow material can be handled by scrapers if large boulders are not present. Quarrying hard rock may

require explosives and blasting, but removing soft weathered rock may only require a powerful dozer with ripper teeth. Church (1981) discusses the various dozer attachments available for ripping and their applications.

The wear on equipment used for handling rock and granular materials is significant. Steel tracks on dozers require frequent replacement. Rubber tires are easily cut by sharp rock edges and require frequent replacement, although replaceable chain guards can be used to reduce damage. Special armor plating is needed for the bodies of trucks that haul rock and coarse granular materials.

Acceptable lift thicknesses for rock and granular material are much greater than for fine-grained soils, provided that increased compactive effort is applied. USBR (1998), USBR (1987a) and Sherard et al. (1963) recommend a lift thickness of one to two times the maximum rock diameter for rock fills that contain fines, while USACE (1995b) recommends that lift thicknesses for rockfill dams be no greater than 24 inches unless test fills show that adequate compaction can be obtained using thicker lifts. This guidance may require modification for mine spoil conditions where large rock on the order of the lift thickness may inhibit densification of surrounding spoil or where uniform gradation or maximum hydraulic conductivity characteristics are critical. In situations where the largest dimension of rock in the fill approaches the desired lift thickness, the interstices around the rock should be filled with finer materials and compacted until there is no visible evidence of consolidation of the material being compacted. The recommended lift thickness for gravel is about one foot, but this can be increased to two feet or more if the gravel is coarse. Vibratory compactors are very effective on rock and clean granular fill and may allow even higher lift thicknesses. The type and size of vibratory compactors required depends on the borrow material characteristics and lift thickness.

The water content for rock and granular fill is relatively unimportant. However, wetting of rock and clean gravels used for compacted fill will minimize friction between contact points of adjacent particles, allowing them to approach maximum density with reduced compactive effort.

Density controls for rock and granular fills are not as precisely defined as for fine-grained soils, and use of a method specification (i.e., minimum number of passes by construction equipment) based on site-specific observations may be appropriate. It is relatively difficult to take accurate in-place density tests for rock fills, as discussed in [Section 11.8](#). Careful observation of the action of compaction equipment is an important part of evaluation of the effectiveness of the placement and compaction process. Key points to watch for include the following:

- Compaction efforts should continue until no further decrease in the lift thickness is observed during a pass of the compaction equipment.
- When compaction is complete, loose fine particles on the surface near the compaction equipment bounce due to vibrations transmitted through dense fill.
- When compaction is complete, the edges of adjacent rock particles will be crushed from being wedged into a tight position. Further compactive effort will only increase the amount of crushing rather than significantly increase the density. If the presence of crushed rock particles reduces desired drainage, compaction should be closely observed and terminated when crushing begins to occur.

11.6.6.3 Use of Mine Spoil

Mine spoil may be an acceptable borrow material for use in refuse disposal embankments, including structural zones, provided that the material characteristics are identified and accommodated in the design and construction. Mine spoil may include substantial portions of fine silt and clay materials, but typically is predominantly granular materials and large rock. Accordingly, in a zoned embankment, more pervious mine spoil would be placed downstream of less pervious embankment mate-

rials such as coarse refuse. Key issues are the consistency of the spoil borrow source material and measures that need to be implemented so that it meets design requirements. Internal erosion of finer material into mine spoil is a particular concern. Characterization, design, and construction considerations of mine spoil are presented in [Section 8.8](#).

Characterization of mine spoil can be accomplished by: (1) review of the mine overburden geology, (2) use of exploration test pits and borings to obtain samples for testing, and (3) performance of geophysical surveys to determine density and shear-wave velocity. The durability of the spoil material should be evaluated; in particular drainage and grain-size characteristics are important. Use of larger specimens for laboratory testing to obtain a representative sample may be needed. Measures that may be necessary during construction include segregation of large rock (using screens or in some instances during lift placement using dozers and graders) and rigorous quality control testing to verify material properties. Additionally, it may be desirable during mining operations that will provide borrow material, to strip and segregate soil and some rock strata (e.g., shales) from more durable rock strata for subsequent use.

11.7 FACILITY APPURTENANT STRUCTURES

Facility appurtenant structures generally require materials and construction procedures that are different from those for the disposal of refuse. These structures generally include, but are not limited to:

- Internal drainage systems in the refuse embankment such as internal drains, drainage trenches, etc.
- Spillways, decant structures and other major hydraulic control structures
- Minor surface drainage structures such as collection ditches, erosion control devices and culverts
- Haul and access road bridges and miscellaneous buildings associated with refuse disposal operations
- Mine-opening/auger-hole seals and drains

Discussion of material requirements and construction procedures for various types of appurtenant structures is provided in the following pages.

11.7.1 Material Requirements

The potentially corrosive nature of some coal refuse or leachates from the coal refuse makes material selection important if the appurtenant structures are to function as intended for long periods and into abandonment. [Table 11.6](#) presents the most common construction materials used for facility appurtenant structures, shows the corrosive or deterioration mechanism for each material, and indicates protective measures that may be taken.

Coal refuse, and particularly leachate water therefrom, should be chemically tested for corrosive components. Typically, leachates will be acidic (low pH value) and will contain sulfates that cause corrosion of many materials. Coal refuse varies significantly, and testing is advisable prior to identifying appropriate protection measures at a particular disposal facility.

11.7.2 Filters and Drains

Control of water flowing across a disposal site, or seeping through an embankment or its foundation, is an important factor in satisfying both safety and environmental requirements. Design requirements for limiting, controlling and collecting these flows are presented in [Section 6.6.2.3](#).

TABLE 11.6 EFFECTS OF CORROSION AND COUNTERMEASURES

Facility Component	Materials and their Corrosive or Deterioration Mechanism	Protective Measures
I. Internal Drainage Systems		
A. Bank run gravels and sands or crushed rock	<u>Sandstones</u> : If the bonding agent between sand grains is silt particles or clay flakes consisting of calcite (CaCO ₂), sandstones will be attacked by acidic leachates.	Use only corrosive resistant sandstone with silica bond (SiO ₂).
	<u>Limestones</u> : Mineral calcite (CaCO ₃) will be dissolved by acidic leachates.	Do not use in internal drainage system.
	<u>Shale</u> : Silt and clay composition breaks down when subjected to weathering or moisture.	Do not use in internal drainage system.
B. Geosynthetics	Nylon, Polypropylene, Polyester, HDPE, PVC: Good corrosive resistance.	Most materials are sensitive to excessive heat. Protection from ultraviolet light is necessary prior to installation.
C. Drainage and transport pipes	<u>Steel and Corrugated Metal</u> : See discussion of metal products, Item III below.	Galvanizing and/or coating with asphaltic or epoxy protective material or coal tar. Asphaltic and coal tar coatings are susceptible to damage. Asphalt and coal tar pipes are not recommended in critical situations. Properly designed epoxy-coated steel pipes can be considered for critical situations. Use thick-walled pipe to account for corrosion; applicable if rate of corrosion is relatively low. Cathodic protection in vulnerable areas. Use special alloy steels, stainless or other, (See discussion of Metal Products under Item III).
	<u>Cast Iron</u> : Same as steel, but corrosion may form protective coating on metal under ideal conditions.	Coating with asphaltic protective material or coal tar. Coating is susceptible to damage and is not recommended in critical situations. Use thick-walled pipe to account for corrosion; applicable if rate of corrosion is relatively low. Cathodic protection is required in vulnerable areas.
	<u>Plastic (General)</u> : Excellent corrosion resistance.	Consideration should be given to the compatibility of plastic pipe materials with bedding preparations and backfill.

TABLE 11.6 EFFECTS OF CORROSION AND COUNTERMEASURES
(Continued)

Facility Component	Materials and their Corrosive or Deterioration Mechanism	Protective Measures
C. Drainage and transport pipes (Continued)	<u>Polyethylene</u> (PE): Excellent for corrosive liquid transport and backfill.	Check characteristics and strength for the density PE pipe considered. Outside diameter controlled HDPE, when properly designed, can be used in critical situations.
	<u>ABS</u> : Good corrosion resistance.	Check characteristics and strength of ABS pipe.
	<u>PVC</u> : Good for use with corrosive solutions below 140°F, brittle at low temperatures.	Do not use when temperature above 140°F may be contacted. Check allowable application of specific PVC type used.
	<u>Concrete</u> : See discussion on Concrete Structures, Item II below.	
	<u>Thermosetting</u> : Epoxy and polyester resin reinforced (fiberglass and filament wound) and non-reinforced pipe.	Check properties of specific resin used for strength, temperature effects and corrosion resistance.
D. Gates and miscellaneous metal work	See discussion of Metal Products under Item III.	
II. Concrete Structures (spillways, decant structures, channels, outflow conduits, etc.)		
A. Cement	The bonding agent in ordinary concrete (hydrated Portland cement) leaches when exposed to acidic waters.	Use Type II or IIa cement for contact with water containing (100 to 150 ppm) sulfates as SO ₄ .
	Sulfates in water or refuse react with tricalcium aluminate in cement causing swelling and disintegration of concrete.	<p>Use Type V cement for contact with water containing greater than 1000 ppm of sulfates as SO₄.</p> <p>Provide coatings for concrete structures as discussed in ACI (2005) Committee 515 report.</p> <p>Low water-cement mix ratios result in less permeable concrete thus reducing penetration of water-containing, deleterious compounds. Air entrainment and other additives are also recommended for increasing resistance to water penetration and improving workability of low-water cement mixes.</p> <p>Replace concrete materials with materials that are less susceptible to deterioration (e. g., coated cast-iron pipe in place of concrete pipe).</p>

TABLE 11.6 EFFECTS OF CORROSION AND COUNTERMEASURES
(Continued)

Facility Component	Materials and their Corrosive or Deterioration Mechanism	Protective Measures
B. Aggregate	See discussion of bank-run gravels or crushed rock, Item I.A.	
	See also ACI (2005), ACI Committee 201 for reactive aggregates.	
C. Reinforcing steel	See also discussion of metal products under Item III.	
	Porous concrete or inadequate cover permits rapid attack on reinforcing steel. Corroding steel causes expansion, disintegrating the concrete.	<p>Typical concrete cover may protect reinforcing steel if corrosive environment is not severe. For severe environments and long service life, epoxy-coated rebar may be considered.</p> <p>Provide coatings for concrete structures as discussed in ACI (2005).</p> <p>Low water-cement mix ratios result in less permeable concrete and thus provide greater protection against corrosion. Air-entrained concrete is recommended as an aid to placement and for increased resistance to water penetration.</p>
III. Metal Products (gates, valves, outflow conduits, decant pipes, etc.)		
A. Steel	Electrochemical corrosion caused by oxidation in an ionizing medium (water). Rate of corrosion is governed by environmental factors such as hydrogen ion concentration, oxygen concentration, and temperature. For pH between 6.5 and 8.0, corrosion protection is probably not required.	<p>Use internal and external coatings such as asphalt, coal tar, epoxies or other non-reactive materials.</p> <p>Provide cathodic protection. Use sacrificial anodes to reduce corrosion.</p> <p>Use thicker material in construction to account for deterioration; applicable if rate of corrosion as determined from bench or field studies is relatively low.</p> <p>Use special-alloy steels, stainless or other.</p>
	Corrosion caused by reaction with dissolved, ionized or colloidal substances in the corroding medium (water) such as: H ⁺ , O ₂ , CO ₂ , NH ₃ (bacteria), SO ₄ ⁻² , S ⁻² , Cl.	<p>Use of internal and external coatings such as epoxy, asphalt, coal tar, epoxies or other nonreactive materials.</p> <p>Provide cathodic protection. Use sacrificial anodes to reduce corrosion of metal product to be protected.</p> <p>Use thicker material in construction to account for deterioration; applicable if rate of corrosion as determined from bench or field studies is relatively low.</p> <p>Use special-alloy steels, stainless or other.</p>

The material and construction issues associated with design implementation are discussed in the following subsections.

11.7.2.1 Granular and Geotextile Filters

Filters consist of granular materials placed against disposed coal refuse or earth fill where seepage is likely to exit, or between materials of greatly different particle size (e.g., between clayey silt and coarse coal refuse) where seepage flows from the smaller-particle-sized material to the larger-particle-sized material. The primary purpose of a filter is to allow movement of water without allowing fine particles to exit or to move into the coarser material void spaces. Such movement could lead to internal erosion and weaken the fine material. Internal erosion can create voids in an embankment, increase rates of seepage and cause eventual failure. Movement of finer particles can also obstruct the flow within the coarse material. Granular filters may consist of multiple layers. The gradation of each layer should be sized such that finer granular material is unable to enter coarser layers and cause clogging. Geosynthetic materials such as geotextiles can be used in single layer applications or sometimes in combination with granular materials to create multiple layers. Layered granular and/or geotextile systems are commonly used in filter diaphragms and internal drains in slurry impoundment embankments. The National Dam Safety Review Board (NDSRB), which comprises federal agencies that deal with dam safety, recommends that a geotextile not be used as a filter for a critical internal drain in a water impounding dam unless it is accessible in the event that it does not perform as intended.

Granular filters should be composed of durable free-draining granular materials. [Section 6.6.2.3](#) discusses design requirements for grain-size distribution. Filter materials typically should not contain more than five percent clay- and silt-size particles, either before or after placement. Similarly, geotextiles should be designed based on the grain-size distribution of the soil or refuse and apparent opening size of the geosynthetic material. Design requirements and limitations for geotextiles, including guidance for evaluating the potential for chemical and biological clogging, are presented in [Section 6.6.2.3.2](#). Construction-related guidance for installation of geotextiles for filters includes:

- In preparing surfaces for geotextile placement, depressions, holes, and voids should be filled so that the geotextile sheet is continuously supported. The geotextile should be placed to loosely drape the surface with no sagging between surface contact points. Continuous contact between the geotextile and the support material is considered critical in addressing clogging potential (Talbot et al., 2000). Geotextile should not be placed over sharp or angular rocks that could tear or puncture it; an intermediate layer of compatible finer material should be placed over such rock as a bedding layer or protection buffer.
- Geotextiles should be secured by sewing, pins, staples, or weights so that specified overlaps are maintained during construction.
- Adjacent geotextile sheets should generally be placed with upstream layers overlapping downstream layers.
- In placing material on a geotextile, care must be taken to avoid punctures or tears. The construction specifications should limit the size and drop height of rocks to be placed on the geotextile. Generally, stones weighing more than 250 pounds should be placed with no free fall. Field trials should be made to verify that no damage will occur due to the rock placement procedures, or a cushion layer of finer material may be utilized to protect the geotextile.
- Geotextiles should be covered or protected as soon as possible to prevent degradation or damage from exposure or equipment traffic and to prevent fines from accumulating on the fabric. Manufacturer recommendations relative to exposure should be followed.

Geosynthetic materials are commonly used as filter layers for drainage systems at a refuse embankment and as separating and reinforcing layers for channel linings and haul roads. Similar to granular filters, a geosynthetic material will allow the movement of water while preventing fine particles from entering the voids of a coarser drainage medium. Properties of filtering geosynthetics such as permittivity, hydraulic conductivity, percent open area and apparent opening size must be evaluated as part of drainage system design. Where geosynthetics are employed at internal drainage structures for impounding embankments, performance tests (e.g., gradient ratio test) should be conducted using actual embankment materials. Separating and reinforcing geosynthetics are normally chosen based upon their strength properties such as puncture strength, grab tensile strength, wide width tensile strength, grab tensile elongation, and trapezoid tear strength. Manufacturers' construction guidance for geotextile filters should also be followed when geotextiles are used as a separation layer.

Care should be taken during construction to prevent runoff from washing fine particles into an unprotected filter. Filters should be constructed to an elevation slightly above that of adjacent materials. If this is not practical, diversion ditches should be constructed or temporary coverings should be placed over the filter.

Filter materials should be stockpiled, handled and placed in a manner similar to material used for underdrains, as discussed in the following paragraphs.

11.7.2.2 Granular Underdrains

Underdrains typically consist of trenches filled with granular material, granular blankets, or granular collection zones along stream bottoms in valleys or at isolated seeps or springs. These drains can be constructed with or without perforated pipes for conveying seepage from the collection zone to a safe exit location. The granular zones are generally thin, and typically there are no compaction specifications for the granular material; however, where more extensive granular zones are present, such as with chimney drains, provisions for placement should be provided.

Granular drains or collection zones must remain free-draining. Therefore, drain materials should be selected to: (1) allow flow and act as filter protection for adjacent material ([Section 6.6.2.3](#)), (2) resist deterioration over time, and (3) resist deterioration due to chemical attack. Table 11.6 lists possible effects of chemical attack or weathering on gravels and crushed rock that might be used as granular drainage materials. Granular aggregate used for underdrains and filters should be obtained from reputable suppliers or verified borrow sources. To minimize the potential for degradation, rock used in granular drains should have high durability; applicable rock testing for durability is discussed in [Section 6.5.9.4](#). It is particularly important to avoid the use of most limestone because of the possibility for generation of acidic leachates that can react chemically causing dissolution or degradation. As a quick field test, the presence of limestone in granular material can be determined by placing a dilute solution of hydrochloric acid on the material. If an effervescent or fizzing reaction occurs, the material should not be used. Laboratory test data for both the refuse and the potential drain material should be carefully reviewed prior to the purchase or use of any drain material.

Granular material must not be allowed to segregate prior to placement. [Figure 11.5](#) shows correct and incorrect ways of stockpiling and handling granular materials. The stockpile location and materials handling procedures should be such as to prevent siltation contamination by the loading or unloading equipment or by wind- or water-carried particles. Well-graded materials should not be dropped or allowed to roll down a slope for any significant distance, because the larger particles will separate from other materials by moving to the outside of the pile as they roll down the slope.

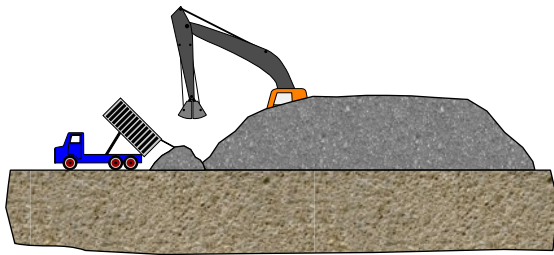

PREFERABLE

CRANE OR OTHER MEANS OF PLACING MATERIAL IN PILE IN UNITS (NOT LARGER THAN A TRUCK LOAD) THAT REMAIN WHERE PLACED AND DO NOT RUN DOWN SLOPES.

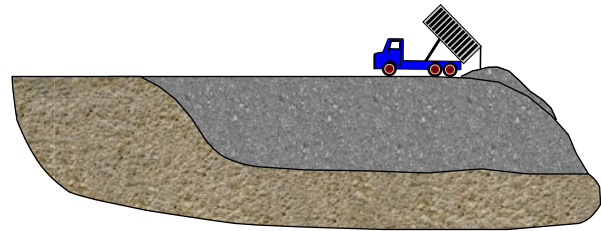

OBJECTIONABLE

METHODS THAT PERMIT THE MATERIAL TO ROLL DOWN THE SLOPE AS IT IS ADDED TO THE PILE OR PERMIT THE HAULING EQUIPMENT TO OPERATE OVER THE SAME SURFACE REPEATEDLY.

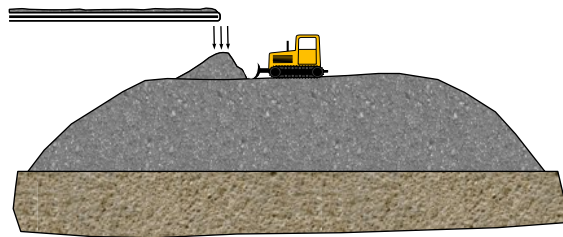

LIMITED ACCEPTABILITY

PILE BUILT RADIALLY IN HORIZONTAL LAYERS BY BULLDOZER WORKING WITH MATERIALS DROPPED FROM A CONVEYOR BELT.

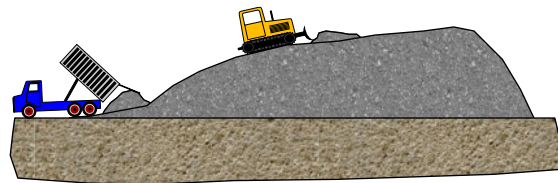

GENERALLY OBJECTIONABLE

UNLESS MATERIALS STRONGLY RESIST BREAKAGE, STACKING PROGRESSIVE LAYERS ON SLOPE NOT FLATTER THAN 3:1.

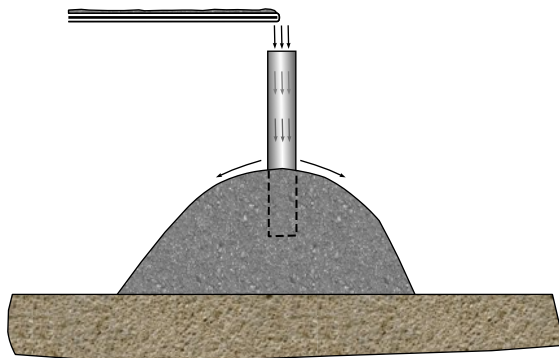

CORRECT

CHIMNEY SURROUNDING MATERIAL FALLING FROM END OF CONVEYOR BELT TO PREVENT WIND FROM SEPARATING FINE AND COARSE MATERIALS. OPENINGS PROVIDED AS REQUIRED TO DISCHARGE MATERIALS AT VARIOUS ELEVATIONS ON PILE.

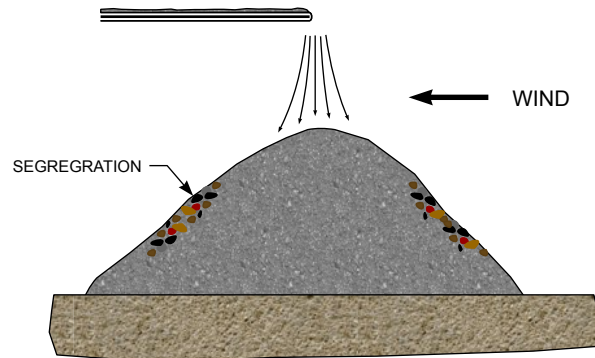

INCORRECT

FREE FALL OF MATERIAL FROM END OF STACKER PERMITTING WIND TO SEPARATE FINE FROM COARSE MATERIAL.

FIGURE 11.5 STOCKPILING AND HANDLING OF GRANULAR MATERIALS

If granular drains must be placed in thick layers, or are critical to the stability of the embankment because of their position, the guidance in [Section 11.6.6.2](#) relative to the placement and compaction of rock and granular fill should be reviewed prior to granular drain construction. Should compaction be necessary, the construction specification should account for potential breakdown of the granular material.

11.7.2.3 Drainage Pipe

Drainage pipes are often placed in portions of the refuse embankment to convey water from the granular drains (internal or surface drains) to an acceptable exit point. Within the collection zone, drainage pipes are normally perforated to facilitate inflow of water that collects in the drain. The remainder of the drainage pipe may or may not be perforated. Drainage pipes should be constructed from a material resistant to chemical attack by refuse leachates and should be sized according to flow capacity and structural requirements. They should generally be designed and installed such that they are self-cleaning and the potential for accumulation of fine material in the pipe is minimized.

Although corrugated metal pipe (CMP) can often be protected by coatings, the potential for coating damage during installation is a potential problem. Since plastic pipe is not normally susceptible to corrosion from acids, it is often more suitable than CMP for drainage pipes in coal refuse.

When perforated pipe is placed, the perforations should normally be placed facing downward. This causes the water to flow up into the pipe, minimizing the chance for transport of fines into the pipe and consequent reduction in flow capacity. Instructions from the pipe manufacturer are often explicit in this respect and should be followed. For most perforated pipe, several rows of perforations are normally provided around the circumference of the pipe. For this type of pipe it will not be possible to orient all of the perforations facing downward. For installation in very fine materials, a double layer filter and granular drain may be needed to prevent fine material from entering the perforations. Such requirements should be detailed in the facility plans and specifications.

Drainage pipes beneath embankments should be designed to withstand the loading of the embankment, with specification of pipe support and backfill that prevents point loading on the pipe. Design and construction of conduits for dams was published by FEMA (2005a), and additional guidance by FEMA related to plastic pipe has also been published (FEMA, 2007). During construction, sufficient fill must be placed over the pipe before traversing it with heavy equipment. Manufacturers' recommendations should be checked.

11.7.3 Culverts and Decants

Conduits are often used for transporting decanted impoundment water and flood water beneath embankments and also for culvert-type spillways. Conduit materials should be selected on the basis of strength and resistance to corrosion. Potential corrosion and deterioration mechanisms for conduit materials are discussed under Item I-C (Drainage and transport pipes) in [Table 11.6](#). Progressive deterioration of large conduits that are critical to refuse facility hydraulic systems is not acceptable, and effort should be made to prevent loss of conduit flow capacity, leakage that can lead to material infiltration or exfiltration, and structural distress.

Conduits require special bedding or thrust blocks at turns. Uniform contact around and under the conduit is essential, particularly at thrust-block areas. When conduits associated with decant systems and culvert spillways are installed in critical areas, such as through impounding embankments, special provisions are required for performing compaction beneath and around the conduit to minimize the potential for seepage along the exterior of the pipe. Compaction beneath the haunches of the pipe is difficult and normally can not be accomplished unless special materials and designs are employed. Concrete cradles and sand bedding have been used to improve the support beneath and around conduits.

Other more specialized materials and methods such as use of flowable backfill or the cut-earth cradle method can be employed for conduit installation. Flowable fill, or controlled low-strength material (CLSM), is a low-strength, fine-aggregate concrete with unconfined compression strengths between 50 and 200 psi. The use of flowable fill to backfill a conduit trench and serve as bedding for the conduit provides firm support extending from the spring line around the base of the conduit. Flowable fill has the added benefit of having low hydraulic conductivity. The mix must be designed to prevent shrinkage and to have satisfactory strength/deformation characteristics, as discussed in [Sections 6.5.10.2](#) and [6.6.6.3.3](#). Either shrinkage or cracking of flowable fill will allow a flow path for seepage.

The cut-earth cradle method involves compaction of select material at the base of the conduit location and subsequent excavation using a specialized attachment on an excavator resulting in a semi-circular cradle excavation. The cradle excavation is sized and shaped so that it closely fits the conduit. A material such as bentonite powder has been used to compensate for small, discontinuous gaps between the cradle and the pipe. The depth of the cradle should be approximately one-half the diameter of the pipe. This method requires a high level of quality control in order to prevent a flow path from occurring along the pipe.

To collect and discharge any possible seepage along the conduit in a controlled manner, a filter diaphragm is recommended regardless of the method employed for conduit backfill and support.

11.7.4 Concrete Structures

Coal refuse disposal facility appurtenant structures that may be totally or partially constructed of concrete include spillways, decant structures, culverts and drainage channels, as well as foundations for various small structures. Such concrete work is not unique to coal refuse disposal facilities, and most applications are extensively discussed by the ACI (2007), the USBR (1992b) and in numerous concrete design textbooks.

Chemical attack and deterioration and related preventative measures are key considerations in the use of concrete for any facility structure that may be in contact with coal refuse or leachates from coal refuse. [Table 11.6](#) presents a summary of major considerations. Although acidic leachates are an obvious corrosive environment, it is emphasized that for concrete durability it is also important to guard against the sulfates common to coal refuse and coal refuse leachates. The USBR (1987a) shows typical examples of sulfate attack and discusses methods for retarding it.

Before specific protective measures for concrete exposed to coal refuse and leachates are selected, the acidic potential and sulfate contents of the refuse should be evaluated. Chemical testing is recommended. Concrete structures exposed to natural ground adjacent to coal refuse disposal facilities should also be protected from deterioration by chemical attack. Groundwater in and around coal refuse may contain corrosive elements and can cause concrete deterioration even if the concrete is not in direct contact with coal refuse.

Minimum practices and protective measures for concrete used in or near coal refuse disposal facilities should include:

- Use of sulfate-resistant cement (preferably Type V, but in some mine environments Type II cement will suffice). Depending on cement availability, Type II or Type I cement in combination with pozzolans (e.g., fly ash, slag cement) may provide adequate sulfate resistance.
- Low water-cement ratios and relatively rich mixes should be used so that dense, high-strength concrete results.

- Air entrainment should be used to increase the workability of low water-cement ratio mixes and to decrease the hydraulic conductivity of the hardened concrete. The use of other water reducing chemical additives to allow further reduction of the water-cement ratio and to provide increased strength should also be considered.
- Extra cover concrete should generally be provided over all reinforcing steel.
- Fresh concrete should be thoroughly vibrated to maximize densification and to eliminate honeycombing.
- Concrete should be thoroughly cured to maximize strength gain.

Many protective coatings discussed in the following section are also applicable to concrete structures, although application and maintenance may be more difficult than for application to metals.

11.7.5 Gates, Valves, Pipelines and Other Metal Work

Metal work in and around a coal refuse disposal facility must be protected against corrosion from chemical attack. Special alloy steels may offer good protection against corrosion, but their selection should be made with care because some types of alloy steels are actually more susceptible to attack from certain chemicals than regular construction grade carbon steels. The cost of many alloy steels is similar to carbon steel, but cost must be evaluated on a case-by-case basis. [Table 11.6](#) summarizes various types of chemical attack and corresponding measures for protection.

Installation of metal products with protective coatings is common, but installation should be accomplished in strict accordance with the recommendations of the coating manufacturer. Various coatings are available that will provide adequate protection if the integrity of the coatings is maintained during construction and operation. Coatings should be: (1) continuous, (2) not support bacterial growths or absorb water, and (3) not deteriorate with time. Epoxy coatings are very durable and provide excellent protection against corrosion and bacterial growth. However, field application of epoxy coatings is difficult and requires special surface preparation per the manufacturer's recommendations. Coal tars meet all of the coating criteria and are one of the best bituminous materials available for protection of steel surfaces. Asphalt coatings are an alternate low-cost bituminous coating. However, if bituminous coatings are scratched or damaged during installation, they must be repaired prior to completion of the installation.

Special vinyl chloride or chlorinated rubber coatings are also available for corrosive protection. Application of these coatings must be made in strict accordance with recommendations of the manufacturer, as there are significant differences in methods of application.

Imperfect coating of metal may actually lead to more rapid deterioration than no coating at all. This can occur where galvanic action is very strong. If the predominant portion of the metal is protected by materials that resist electrical currents, galvanic action will concentrate at points of imperfection, leading to very rapid removal of the metal at these locations. Protection against this type of corrosion requires installation of a sacrificial anode designed by a professional experienced in corrosion protection. USACE (1985) and USACE (2004) provide background information and guidance on testing and design for cathodic protection.

11.7.6 Support Structures

Offices, maintenance buildings, loading bins, etc. should be built in accordance with applicable building codes and generally accepted construction practices. Coal refuse can often be used effectively for structural fills on which such structures are constructed. The same precautions against material deterioration due to acid or sulfate attack should be taken. Drainage and utility pipes, foundations and electrical conduits are all subject to corrosive action if exposed to coal refuse or coal refuse leachates.

11.7.7 Mine-Opening and Auger-Hole Seals and Drains

Depending upon their location within an embankment or impoundment area, the presence of mine openings and auger holes in coal seams should be addressed with backfilling, barriers, bulkheads, seals or drains. The construction materials for these structures can range from structural materials such as cast-in-place concrete or block to aggregate materials for construction of filters and drains. On-site borrow materials may be specified for backfill or for compacted fill as part of a barrier.

11.8 QUALITY CONTROL AND FIELD TESTING

Quality control and field testing are required for verification that a refuse facility is constructed according to plans, specifications and the operation and maintenance plan. The principal concerns for construction of a coal refuse disposal facility include:

- Compaction control where refuse is to be used as structural fill.
- Compaction control where borrow materials are to be used as structural fill.
- Verification that all areas that require structural fill are so constructed.
- Verification that material properties that affect construction operations, such as grain size, water content and compaction characteristics are in accordance with specifications.
- Verification that facility appurtenant structures, especially conduits and open channel spillways, are being constructed in accordance with design requirements, manufacturers' recommendations and good construction practice.

Activities that require quality control can be identified through review of the design report, plans, specifications, operation and maintenance plan for the facility, and technical chapters of this Manual, particularly Chapter 6.

11.8.1 Compaction Control

The monitoring of compaction in the field is essential for verification that structural fill refuse is compacted to a density meeting design requirements. The density of fill material should be tested in order to verify that the pertinent engineering properties of the fill that are a function of density, such as shear strength and hydraulic conductivity, are consistent with the values used in the design. Compaction control entails field testing during the construction of embankments and at other areas requiring structural fill refuse. Compaction test locations should be selected so as to include areas where routine compaction activities are performed, as well as areas that are more difficult for compaction equipment to access with repeated passes or where successful compaction is doubtful. At some sites, a grid system has been employed to aid in test location selection, and for each lift random grid points are chosen for testing. USBR publications (1987a, 1992a, 1998) discuss methods for testing compacted fill materials.

The in-situ density testing of structural fill has become much easier and more efficient with advances in nuclear testing methods. Unless special conditions arise during fill construction, most structural fill refuse, fine-grained soils, and fine gravels can be density tested using a nuclear density-moisture gauge. USACE (1995b) provides guidance on the use of these types of gauges, which should be operated in the direct transmission mode. Nuclear density-moisture gauges provide direct readings of in-situ density and the moisture content of fill. The instrument operates by projecting radiation (gamma rays) into the fill and measuring returns with a Geiger-Mueller detector. The instrument is easy to use and requires only observation of a digital read-out. However, the presence of varying amounts of hydrocarbons in coal refuse can cause the gauge to indicate higher than actual moisture contents.

Therefore, samples should be collected from the tested fill for laboratory moisture analysis so that accurate calculation of dry density can be performed.

For evaluation of the degree of compaction, measured field densities can be compared to Proctor density curves (Chapter 6) developed from laboratory testing. All field test results should be recorded. If test results indicate a lack of compliance with fill density requirements, compaction procedures should be modified. Areas of low density should receive additional compaction. If necessary, unacceptable fill should be removed and replaced, and recompaction should be performed. If it is determined that the fill is being compacted to densities greater than the maximum value from the Proctor test, an evaluation of the material (grain size and specific gravity) and the associated Proctor density curves may be necessary. In some cases, the presence of oversized particles, that is particles too large to be included in the Proctor mold (ASTM D 698), may be causing overestimation of density. If this is suspected, a sieve analysis should be performed and a rock-correction factor should be developed in accordance with ASTM D 4718, "Standard Practice for Correction of Unit Weight and Water Content for Soils Containing Oversize Particles," and used to recalculate the maximum dry density of the refuse.

Application of the ASTM D 4718 may be difficult or precluded when coarse refuse contains more than 25 to 30 percent of plus- $\frac{3}{4}$ -inch particles, even after the oversize correction provisions using laboratory determined specific gravities are employed. Sometimes the oversize correction yields unreasonable target densities (usually higher than achievable), and in this case other compaction tests or field procedures should be considered. While determination of relative density in accordance with ASTM D 4253 and ASTM D 4254 is a possibility, this is generally not recommended because of the fine content in coal refuse. Another possible method for compaction control is the roller pass test (WV DOT, 1999). This method is discussed in [Section 11.5.1](#).

Alternative material testing methods may be employed when more than 25 to 30 percent of plus- $\frac{3}{4}$ -inch particles are encountered. One such testing method is specified in Appendix VIA of the USACE Publication EM 1110-2-1906 titled, "Laboratory Soils Testing" (USACE, 1986). This method employs a 12-inch-diameter mold that accommodates larger particle sizes. Disadvantages to this method are that it is more costly than the ASTM D698 method, and many geotechnical laboratories are not equipped to perform the test. However, if refuse with a significant proportion of oversize particles is routinely generated, it may be effective to use the USACE test to supplement or replace the roller pass method.

In addition to periodic field density tests, visual observation of refuse placement and compaction should be performed regularly. If compacted material tests as having an "acceptable" density, but the surface is not firm, then the compaction specification should be re-evaluated. Regular observations by field personnel can often lead to acceptable modification of compaction procedures. Such observations are discussed in [Section 11.6](#). Key observations for control of earth-fill operations are discussed by Church (1981) and USBR (1998). These observations, which typically apply to refuse disposal operations, include:

- Changes in lift thickness with subsequent passes of compaction equipment (including controlled routing of haul units) should be noted.
- Compaction equipment should not excessively "weave" or "rut" the fill. If this occurs, the material is too wet to be properly compacted.
- The compacted fill surface exhibits "pumping" under construction equipment traffic, which may indicate that lifts below the surface were compacted at too high a moisture content, and need to be uncovered and reworked.
- The feet of a sheepsfoot or tamper-type roller will first penetrate the loose material of a new lift, but should then begin to ride up on the material with each successive pass, as compaction is performed.

A consistent and reliable compaction procedure based upon a sufficient number of passes with appropriate equipment should be established. The USACE (1995b) provides general guidance relative to the number of passes required for various earthfill materials. Site-specific conditions must be considered in establishing compaction parameters.

It is recommended that structural fill refuse be compacted to at least 95 percent of the maximum dry density determined by the ASTM D 698. The refuse should be placed at a moisture content in the range indicated in the plans and specifications, typically in a range of -2 to +3 percent of optimum. The moisture content should be uniform throughout each lift. At least one field density test should be conducted for every 2,000 cubic yards of compacted structural fill with at least one test per lift. A common specification for compaction of pipe backfill and around structures is: at least one density test for every 200 cubic yards with at least one test per lift. Because of the importance of achieving adequate and consistent compaction of pipe backfill, more frequent density testing should be conducted. It is recommended that multiple tests be performed so that the testing frequency is significantly lower than every 200 cubic yards. Testing should also be performed whenever it is suspected that adequate compaction is not being achieved.

If failing density tests occur, it is the responsibility of field personnel to determine the cause of the failed tests. Generally, failed density tests are a result of either insufficient compaction or a change of material from that tested in accordance with ASTM D 698. If it is suspected that the fill was not placed and compacted adequately, the limits of the lift and/or area should be marked, and mine personnel should be notified that the lift/area requires reworking and additional compaction. No additional refuse should be placed in the area with failed density tests until it has been adequately compacted. Additional density tests should be taken after the lift/area is reworked to verify the effectiveness of the additional compaction effort. If it is believed that the lift/area has been placed and compacted adequately, and a variation in grain-size distribution of the refuse being placed is suspected, a new sample should be collected for the ASTM D 698 testing. The Proctor curve(s) should be verified on a regular basis, typically between quarterly and annually.

11.8.2 Material Testing

The material properties of coal refuse, borrow materials, filter or drain gravels, and concrete can be determined by on-site field testing and/or by submittal of test samples to a qualified testing laboratory. Laboratories should be selected based on qualifications. The AASHTO Materials Reference Laboratory (AMRL) performs evaluation and accreditation programs for many construction materials, and the Geosynthetic Accreditation Institute – Laboratory Accreditation Program (GAI-LAP) performs similar evaluations for synthetic materials. Laboratories should be accredited through these programs for the type of testing being performed. Water contents and fill densities are best tested in the field for real-time assessment of compaction efficiency, but occasional test verification by an independent source may be appropriate. Strength testing of refuse, soils, concrete and other construction materials generally requires laboratory equipment and in some instances may be incorporated into quality control programs cited in the construction specifications.

Routine sampling and testing of construction materials is recommended during the development of a refuse disposal facility. The resulting records can be used for future evaluation of material performance and for submittals to regulatory agencies. Most importantly, material sampling and testing during construction increases confidence that the work is being performed in compliance with design requirements.

Chapter 12

MONITORING, INSPECTIONS AND FACILITY MAINTENANCE

Routine monitoring and inspections are essential to the successful construction and operation of a coal refuse disposal facility. Inspections, as described herein, include the components of observations, testing and instrumentation measurements, as performed by a representative of the Mine Owner/Operator (Operator) in accordance with 30 CFR § 77.216-3. Personnel responsible for monitoring and inspections require MSHA impoundment inspection training and/or qualifications and should work with a registered Professional Engineer who is familiar with the design of the disposal facility (Engineer). It is recommended that the Operator designate an Engineer to provide assistance with the implementation of design plans and specifications, assess the performance of the facility, report on the progress of the construction work, and render professional opinions regarding the conformance of construction, operation, and maintenance activities with design plans and specifications. Note that the guidance in this chapter is not intended to address work-site safety issues or daily safety inspections.

Well executed monitoring and inspection programs during construction will facilitate development according to plans and specifications and aid in identifying modifications to the design that may need to be made. Routine inspections during operation of the facility allow for the identification of potential problems and resolution in a timely manner. Observations made during monitoring and inspections can provide a basis for either increasing or decreasing certain maintenance activities. This chapter is generally focused upon monitoring and inspection programs and their relationship to facility maintenance during development and operation of the refuse disposal facility. These programs may also be required during abandonment and reclamation of a coal refuse embankment.

Monitoring and inspection requirements should be established during the design of a coal refuse disposal facility and should be documented in the Operation and Maintenance Plan, which should clearly indicate the roles and responsibilities of various parties in monitoring and inspection activities. Sufficient controls should be in place so that, when monitoring and inspection is performed as specified, the intent of the design is met and satisfactory performance of the facility is achieved. Monitoring normally includes observation of work activities during facility construction, including those activities required to initially prepare the site. Monitoring may encompass such activities as visual observation, collection and analysis of quality control samples, performance of field and laboratory testing, evaluation of construction methods, collection and review of instrumentation readings and evaluation of survey data.

Inspections for evaluating performance are typically conducted for the overall facility and at areas that have been recently constructed. These inspections normally include visual observations; collection of physical data, instrument readings and flow rate measurements (if applicable); and evaluation of the assimilated data. Photographing of site conditions, during construction and operation, is an excellent way to document site conditions and any changes in conditions and is a recommended practice. Information from previous inspections and monitoring activities should be reviewed and compared to current data and plotted instrumentation data so that an informed evaluation can be made. In accordance with 30 CFR § 77.216-3, facility inspections for impounding refuse facilities must be performed on a 7-day basis unless otherwise approved by the MSHA District Manager. Annual reporting and certification requirements for impoundments are provided in 30 CFR § 77.216-4. Additionally, some states have inspection, reporting, and certification requirements that differ from the federal requirements. Annual dam safety inspections may be required by some state regulatory agencies, but these can generally be combined with the MSHA annual reporting and certification requirements.

It is recommended that monitoring and inspections generally be performed under the guidance of a registered Professional Engineer who is familiar with the design (including safety criteria for the structure) and involved in the implementation of the construction plans and specifications. Thus, this individual can prepare required reports and certifications and can assess: (1) conformity with the approved design, (2) significance of the instrumentation records, (3) potential conditions that may warrant notification of agencies including MSHA, and (4) design modifications and remedial construction activities that may be needed. Typically, the design engineer performs or contributes to this activity. In describing the monitoring and inspection activities in this chapter, and particularly actions that may be in response to observed conditions, test results, or instrumentation readings, reference is made to the Engineer in situations that are typically important for such an individual to assess and determine subsequent action. The Engineer's involvement in other activities may also be important, and the site-specific Operation and Maintenance Plan should cite monitoring and inspection requirements. By maintaining the involvement of a registered Professional Engineer who is thoroughly familiar with the design during construction and operation, the mine operator is in position to assess conformity with the approved plan and to respond to regulatory agencies regarding performance or compliance concerns.

If potentially hazardous conditions develop, MSHA requires under 30 CFR § 77.216-3 that the Operator take action to: (1) eliminate the condition, (2) notify the District Manager, (3) notify and prepare to evacuate miners who may be affected, and (4) perform inspections on an eight-hour or more frequent basis. The Engineer should be a source of technical advice in such situations. Potentially hazardous conditions can be identified based on criteria established for Emergency Action Plan preparation, as discussed in Chapter 14.

Facility maintenance includes routine recurring actions for establishing vegetation and controlling erosion, periodic actions after unusual events such as clearing debris, and long-term actions in response to deterioration of structures, such as repair of channel linings and maintenance of embankment slopes. Monitoring and inspections may identify conditions that are inconsistent with the Operation and Maintenance Plan because of differing site conditions, construction procedures, or performance. In such situations, new maintenance requirements may need to be developed.

12.1 MONITORING AND INSPECTIONS

There is an inherent degree of uncertainty in the engineering design of a refuse disposal facility that can normally be offset by applying factors of safety in analytical procedures and by using conservative estimates of material properties. Engineers, particularly in the geotechnical fields, have developed observational/monitoring procedures to deal with these uncertainties without being overly

conservative. The following is a brief listing of the purposes for monitoring and inspection and the basis for their incorporation into refuse disposal facility development:

- Construction quality can vary depending on the specific activity, site conditions, equipment and personnel, all of which can affect facility performance. Monitoring and inspection provide a means of controlling adherence to design requirements and documenting construction quality.
- Geologic conditions can vary significantly at a site. These variations can be accommodated by monitoring and inspection programs during construction and the use of reasonable factors of safety in the design. Monitoring during construction enables evaluation of the validity of design assumptions and analyses and provides an opportunity to make changes as needed.
- Because it is impractical to investigate all natural conditions at a site or anticipate every aspect of facility operation, confirmation of design assumptions through monitoring and inspection can offset limitations in site exploration.
- The long operating life of a refuse disposal facility can lead to many changes in site conditions. For example, changes in coal cleaning procedures and refuse characteristics may occur due to mining of different coal seams during the operational period. An effective monitoring and inspection program can identify when significant changes are occurring or performance problems are developing, so that appropriate modifications can be made quickly when implementation is least difficult and expensive.
- Monitoring and inspection programs form the basis for determining when routine maintenance is needed in order to limit the deterioration of important facility components.

Monitoring and inspection rely heavily on visual observation and are supported by quality control testing, instrumentation, and engineering evaluation. The complexity of a monitoring program can range from simple visual examination of surface conditions to sophisticated surveys using electronic equipment. The simplest means are usually the most effective, especially for the constantly changing conditions associated with coal refuse facilities. A more complicated monitoring and instrumentation program may be justifiable when the information obtained can result in an improved design, operation or significant savings in construction costs. Regardless of complexity, a monitoring program is successful only if the information obtained is pertinent to the design and operation and the data are accurate and measured, recorded and properly interpreted by qualified persons in a timely manner. Accordingly, any monitoring program must be based on knowledge of design requirements, and the observations and measurements must be obtained and interpreted by staff cognizant of the purpose for and limitations of the instrumentation.

12.1.1 Monitoring and Inspection Objectives

Important objectives for monitoring and inspection at coal refuse facility sites include the following:

- Validating the assumptions upon which the design was based – A valuable function of monitoring programs is to provide data for verifying that the assumptions upon which the facility design is based are valid. Therefore, it is critical that monitoring data be evaluated by an engineer who is thoroughly familiar with the design and associated engineering analyses and assumptions and who is responsible for certification of the work.
- Providing data for improving construction methods – As an example, the compaction equipment being used at a site may produce an undesirable particle compaction arrangement that, in turn, affects properties such as strength or hydraulic conduc-

tivity. Through observation of embankment construction, changes can be made in equipment selection, traffic routing, drying or wetting, or other factors such that the desired results are achieved.

- Providing a means for early detection of potential problems or areas requiring maintenance or remedial improvement – A field monitoring and inspection program can identify problems before conditions deteriorate to the point that extensive repair is required or failure can occur. The natural variability of earthen and coal refuse materials may result in unexpected deviations from the original design. Changes in the rate of refuse placement could alter embankment elevations and pool levels, affecting embankment stability.

A project-specific failure modes analysis can be useful in establishing site-specific monitoring and inspection objectives, particularly for facilities with impounding embankments (Martin and Davies, 2000). Through an objective review of potential modes of failure of the disposal facility, considering all loading conditions and design features, the most important monitoring, instrumentation, and inspection objectives can be identified. Martin and Davies suggest the following process:

- Identification of potential failure modes and corresponding warning signs.
- Evaluation of how quickly failure could occur and how potential problems could be detected before they develop into incidents.
- Critical assessment of how likely it is that warning signs will be detected, recognized, reported and acted upon.
- Identification of instrumentation types and locations that provide the most relevant monitoring data.
- Evaluation of the significance of data trends as opposed to single measurements/observations.
- Evaluation of the value of establishing acceptable parameter limits or other limiting criteria.
- Review of lines of responsibility and communication.
- Review of data management, interpretation, action plans, and reporting.

Figure 12.1, as modified from Martin and Davies (2000), illustrates the relationship of failure modes, warning signs, and surveillance measures for tailings dams.

12.1.2 Visual Observations

The simplest, but often most valuable, monitoring method is visual observation by experienced personnel of important facility components and the surrounding area on a schedule compatible with site activity and the rate at which the facility configuration is changing. The required frequency for observations and the level/knowledge of the individual performing the observations should be established by the designer and should be consistent with federal and state requirements. The following should be considered when developing a schedule for visual observations:

- The type of refuse facility (impounding or non-impounding) and stage of construction.
- Specific critical construction items (e.g., internal drains, surface channels, decant pipe, cut-off trench) that should be observed.
- Specific operational areas or items (e.g., spillway operation) required for evaluating performance and potential design modification.
- Identification of components/areas that require only periodic monitoring and inspections and their frequencies.

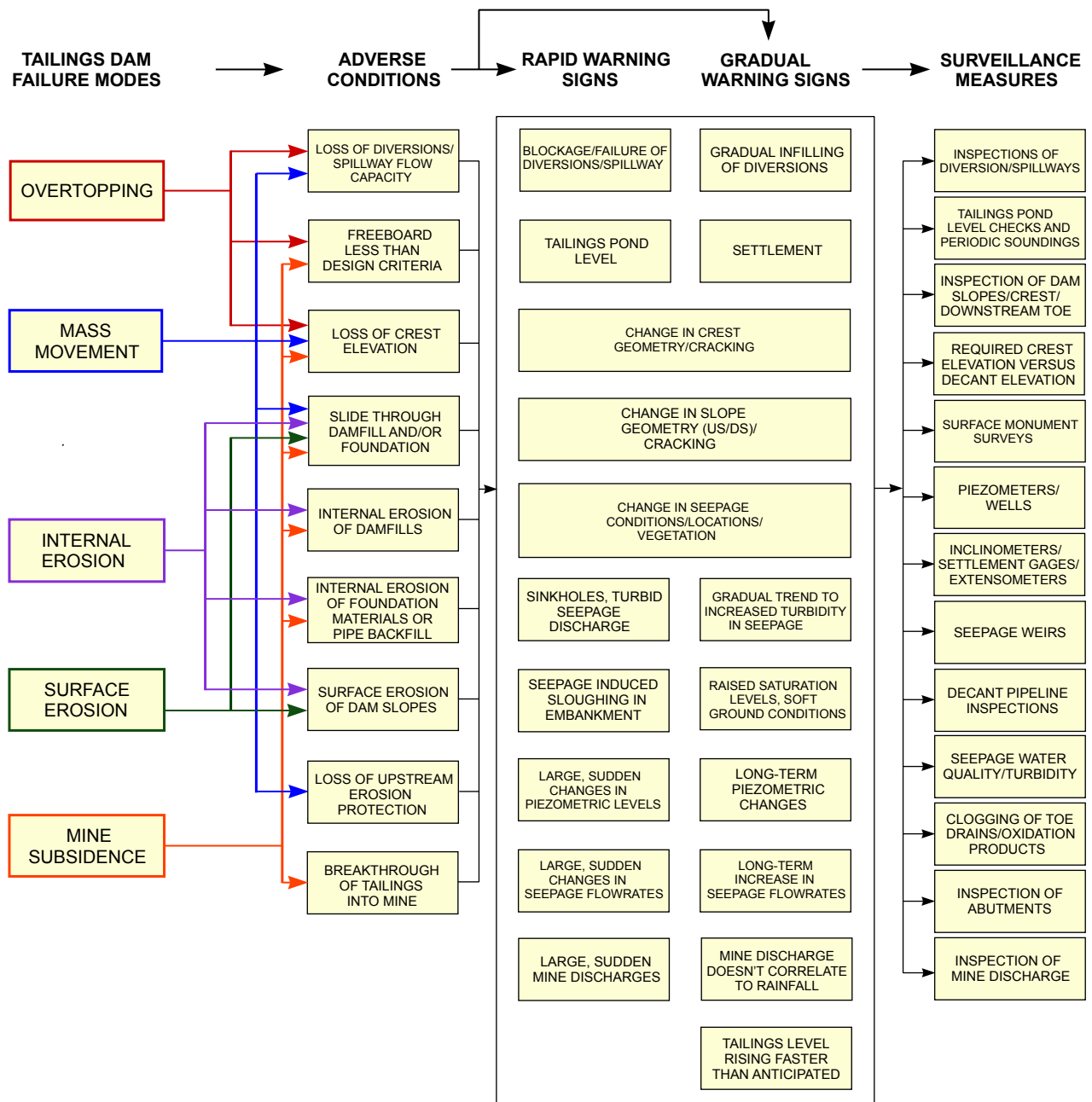

(ADAPTED FROM MARTIN AND DAVIES, 2000)

FIGURE 12.1 FAILURE MODES, WARNING SIGNS AND SURVEILLANCE MEASURES

Components/items to be observed depend upon the facility configuration. Typical factors include:

- Facility configuration and type of refuse disposal
- Geotechnical design requirements
- Site mining and foundation requirements
- Appurtenant hydraulic facilities (spillways or decant pipes)
- Environmental control provisions
- Construction procedures

Checklists should be developed for each refuse disposal facility and should be incorporated into the Operation and Maintenance Plan. These checklists should be used in conjunction with the facility plans and specifications. Figure 12.2 presents an example of a data collection form that is incorporated into a site as-built drawing with topographic contours. The combination of the data collection form and as-built drawing provides a good point of reference during monitoring activities and allows areas of concern to be marked without the need for cumbersome descriptions/text. Items such as density test locations, seeps, sloughs, erosion and slurry discharge location can easily be indicated on the drawing.

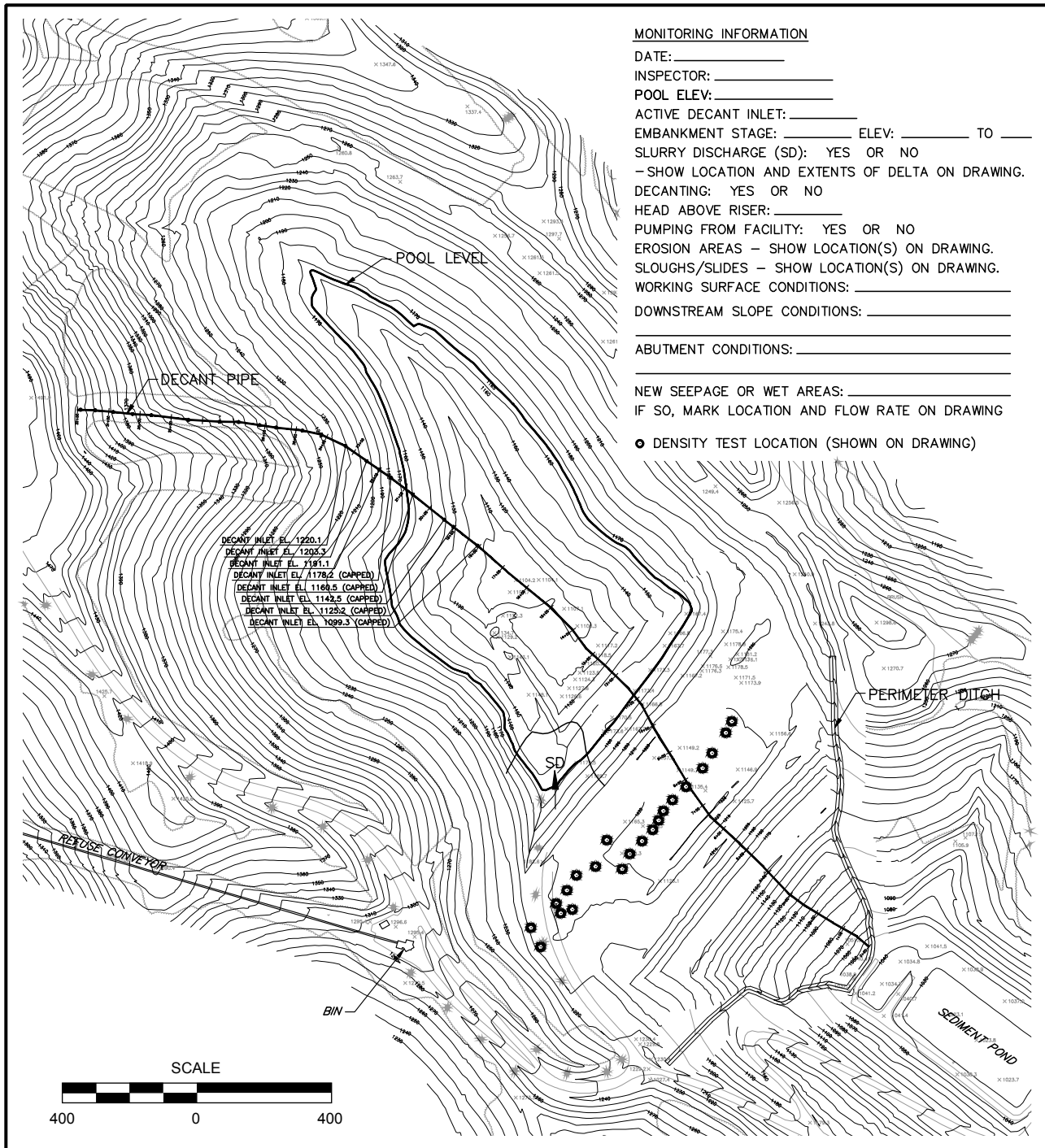

FIGURE 12.2 EXAMPLE DATA COLLECTION FORM

Table 12.1 is a generic list that covers most aspects of refuse disposal facility activity. This list can be used as the basis for development of a site-specific data collection form. Other available references include the *MSHA Coal Mine Impoundment Inspection and Plan Review Handbook* prepared by MSHA (2007) and the *Guidance Document for Coal Waste Impoundment Facilities & Coal Waste Impoundment Inspection Form* prepared by the West Virginia Water Research Institute (2005).

Extensive digital photography is recommended for documenting visual inspections of a coal refuse disposal facility. Photographs not only document the observations made during monitoring or inspection activities, but they can also be used later to track the construction progress of the facility. Photographs are also invaluable for comparing how conditions such as seepage areas change over time. The location and/or orientation of the camera for each photograph should be documented on the as-built drawing or data collection form.

Hand-held global positioning system (GPS) units are very useful for locating items of interest. Most hand-held GPS units can provide position location to within about 10 feet. For most refuse facilities, this accuracy is sufficient for locating sampling or testing locations, wet areas, minor seeps, or other non-critical items. The use of a hand held GPS unit or altimeter unit for elevation determinations is not currently recommended due to lack of accuracy. It should be noted that the GPS coordinates may not conform to the coordinate system used by the mine. Software for performing coordinate conversions is available from commercial vendors.

12.1.2.1 Schedule and Checklist for Visual (and Other) Observations

A schedule for observations should be provided in the Operational and Maintenance Plan. The schedule of observations must be compatible with federal and state regulatory agency inspection requirements. In accordance with 30 CFR § 77.216-3, inspections (not to exceed 7-day intervals) are required for all impounding facilities meeting the requirements of 30 CFR § 77.216(a). Section 12.3 provides additional details relative to embankment/impoundment safety inspections. The recording of data or collection of measurements from installed instrumentation should also be defined in the schedule of observations. Chapter 13 provides additional details concerning the types of instruments available and information related to their installation and use. While 7-day visual inspections are required, continuous monitoring may be appropriate for some critical construction activities (e.g., structures that are ultimately buried, such as decant pipe and internal drain installations, instrumentations, etc.). Alternate frequencies (more or less frequent than every 7 days) for instrumentation monitoring may be desirable.

Inspection of impounding embankments during and after significant precipitation events is recommended. This is a good time to observe the operation of decant and spillway facilities and the outlets to internal drains and to verify that they are functioning properly. Special attention should be paid to whether flow is unobstructed and erosion protection, especially at outlets, is functioning properly. Another important time to observe the operation of a dam is during first filling. The first time the foundation and embankment are subjected to seepage pressures and the first time that flow occurs through, and possibly along, conduits, is an important time to verify that performance is acceptable. Slurry impoundments are constructed over a long period of time and are filled as they are constructed. Special attention should be paid when the saturation level reaches the level of new features, such as conduits. A schedule for observations should be developed for each major aspect of construction of a refuse disposal facility, including:

- Initial site development
- Liner installation (if applicable)
- Starter dam/embankment construction
- Refuse embankment construction

- Instrumentation installation and data measurement
- Appurtenant hydraulic facility construction
- Backfill and abandonment of impoundments
- Mine barrier, bulkhead and seal construction, if applicable

To be most useful, the checklist/data collection form presented in [Table 12.1](#) should be tailored to site conditions. The completed data collection form/checklist (e.g., [Figure 12.2](#)) should be regularly reviewed by the Engineer. In addition to descriptions of the conditions observed, deviations from the plans and specifications should also be indicated on the form and should be reported to responsible facility personnel (Engineer, Contractor, and Operator).

12.1.2.2 Facility Development

12.1.2.2.1 Site Preparation

Site preparation includes activities such as clearing and grubbing, topsoil/subsoil stockpiling, foundation preparation, and liner installation. These items relate to both initial facility development and facility expansion and are typically performed as individual construction activities rather than as a part of ongoing operations. A brief summary of typical observations associated with site preparation is provided in the following:

- Clearing and grubbing – Clearing and grubbing typically includes removal of unsuitable materials such as trees, tree stumps and roots, brush and other vegetation. Important items related to clearing and grubbing that should be observed and noted include: location and extent, adequacy of vegetation removal, debris disposition, and identification of unanticipated and/or suspect conditions (e.g., mine openings, landslides).
- Topsoil/subsoil stockpiling – Important items associated with topsoil/subsoil stockpiling that should be noted include: location and extent, drainage control provisions, depths removed, location and configuration of stockpiles, identification of unanticipated conditions (e.g., landslides, springs, potential for additional soil removal). Areas where the planned embankment and impoundment are to be located should be observed, particularly where soils have been excavated, to determine potential natural seepage conditions that may not have been evident before disturbance.
- Foundation preparation – Important items associated with foundation preparation that should be noted include: location and extent of work areas; preparation work performed prior to placement of any refuse materials (removal of unsuitable material, proof-rolling, slope modification and removal of rock overhangs, spring collection and underdrain installation, etc.); installation of cutoffs, keys or benches in preparation for refuse placement; and construction of mine barriers or bulkheads.
- Liners – If liners are required, the important items to be noted include: materials (natural or synthetic including properties), thickness placed, compaction (equipment type, tests), performance observations (firm or pumping), and cover protection (soil, vegetation, refuse).

12.1.2.2.2 Starter Embankment and Internal Drains

Following site preparation, construction of a starter embankment using borrow material (soil and rock) or coarse refuse is the first step in preparing a disposal facility site for ongoing refuse disposal. Starter embankments may be zoned or homogeneous. Important items to be observed include

TABLE 12.1 TYPICAL OBSERVATION AND INSPECTION CHECKLIST

Item	General Condition	Changes from Previous Inspection	Item	General Condition	Changes from Previous Inspection
FACILITY DEVELOPMENT			DISPOSAL OPERATIONS AND MAINTENANCE		
1. Erosion and Sediment Controls a. Diversion Ditches b. Silt Fences c. Sediment Traps d. Sediment Ponds			1. Stage of Construction and Refuse Placement (lift thicknesses, compaction, scarification, benching)		
2. Clearing & Grubbing			2. Working Surface and Area Maintenance (survey control, grading and drainage control). Refuse Placement (lifts, compaction, scarification, benching)		
3. Topsoil/Subsoil Stockpiling			3. Embankment Crest and Benches a. Alignment and Grade b. Evidence of Movement (cracks, sloughs, scarps) c. Abutments (benching, drainage control, erosion) d. Crest low point elevation		
4. Foundation Preparation a. Removal of Unsuitable Material b. Collection of Springs c. Underdrain Installation d. Benching, Cut-off or Keyway Const. e. Sealing of Mine Entry Bulkheads and Barriers			4. Embankment Slopes a. Alignment and Slope b. Seepage (flow rates, clarity) c. Slope Movement (scarps, sloughs, bulging) d. Erosion e. Vegetation f. Burning or combustion		
5. Liner Construction (material, thickness, compaction, cover) a. Soil b. Geomembrane c. Geosynthetic Clay Liner d. Other			5. Liner, Foundation and Abutment Conditions a. Drainage Control b. Erosion c. Concentrated Seepage or Boils		

TABLE 12.1 TYPICAL OBSERVATION AND INSPECTION CHECKLIST
(Continued)

Item	General Condition	Changes from Previous Inspection	Item	General Condition	Changes from Previous Inspection
FACILITY DEVELOPMENT			DISPOSAL OPERATIONS AND MAINTENANCE		
6. Starter Dam Construction (material, lift thickness, compaction, scarification, benching and keying,			6. Internal Drains (discharge flow rate and clarity, drainage away from outlet)		
7. Internal Drains (material, filter, placement, covering)			7. Decant Pipe a. Inlet (elevation, inflow depth, debris, clogging, alignment, anti-vortex plate) b. Outlet (discharge flow rate and clarity, debris, erosion, drainage away from outlet) c. Structural Concerns		
8. Decant Pipe or Spillway a. Installation (material, joint connections, trench preparation, bedding, backfill, reaction blocks, pressure testing, cover) b. Inlet (riser material, joint connection, reaction block and foundation, backfill, trash rack and anti-vortex plate) c. Outlet (bank stabilization, stilling basin, animal guard)			8. Channel Conditions a. Alignment and Dimensions b. Debris and Erosion c. Lining System d. Receiving Stream Condition (erosion)		
9. Channel Construction a. Alignment and Grade b. Dimensions c. Lining (material, sub-base filter, thickness) d. Transition and Superelevation Sections (stationing, dimensions)			9. Instrumentation Monitoring (piezometers, weirs, other)		

TABLE 12.1 TYPICAL OBSERVATION AND INSPECTION CHECKLIST
(Continued)

Item	General Condition	Changes from Previous Inspection	Item	General Condition	Changes from Previous Inspection
FACILITY DEVELOPMENT			DISPOSAL OPERATIONS AND MAINTENANCE		
10. Instrumentation (survey monuments, piezometers, weirs, other)			10. Reclaimed Slopes (vegetation development and control, drainage control, erosion, seepage)		
11. Reclamation a. Grading and Stabilization b. Soil and Topsoil Cover c. Revegetation (fertilizing, seeding, mulching) d. Seepage Control (collection, conveyance, treatment)			11. Impoundment and Slurry Deposition a. Abutment Slopes (erosion, instability) b. Water Level and Control (decant inlet, pumping, other) c. Slurry Line Alignment and Discharge Location c. Fines Deposition (location, distribution, delta areas, percent exposed/ above pool level)		
ADJOINING AREAS					
1. Foundation and Abutment Conditions 2. Upstream Watershed 3. Downstream Inundation Area					
OTHER DEVELOPMENT (Work unrelated to the disposal facility)					
1. Within Facility Watershed (potential for increased runoff or landslides) 2. Downstream of Facility (potential to change hazard classification) 3. Within Facility					

Note: Reference should be made to a design or as-built plan drawing.

materials placed, lift thickness and compaction (including density and moisture testing), preparation (scarification) of compacted surfaces before placement of subsequent lifts, and benching of new lifts into adjoining abutments or embankment slopes, etc.

Internal drains are frequently part of starter embankments, and typical observations include: materials used for the drain and filter system, installation conditions (trenched into embankment or constructed on completed lift), placement of drain materials (susceptibility to segregation and contamination during placement and spreading) including geotextiles, drain dimensions and grade, and details for covering the completed installation to protect the drain from erosion.

12.1.2.2.3 Decant Pipes

During installation of decant pipes, the following observations should be recorded: alignment and grade, pipe material and joint connections, corrosion protection (where applicable), installation details (trench configuration), bedding and backfill (materials used and compaction, including density and moisture testing results), seepage control measures (location, dimensions and materials), location and configuration of reaction blocks at changes in alignment and grade, results of pressure testing, and details related to covering of the completed installation and protecting the conduit from damage by heavy equipment traffic. The adequacy of placement of backfill in the haunch area should be given special attention. Details related to the following should be observed for decant inlets: riser configuration and materials, joint connections, foundation and reaction block, riser backfill and compaction, inlet trash rack and anti-vortex plate. For decant outlets details related to the following should be noted: receiving channel bank stabilization or stilling basin, drainage control to preclude backup of water into pipe, and animal guard.

12.1.2.2.4 Channel Construction

Channels may include emergency spillways, decant outlets, diversion ditches, groin or perimeter ditches, haul and access road ditches, and bench gutters. Prior to construction, the upland areas should be observed for evidence of instability that may adversely impact planned excavations. Important observations to be recorded for channels during construction include: alignment and grade, dimensions (width, depth, side slopes), erosion-protection lining (sub-base, filter, lining thickness and material), and details of transition and superelevation conditions at changes in alignment, slope or section (stationing and dimensioning).

12.1.2.2.5 Instrumentation

Instrumentation is sometimes installed during starter embankment construction. Additional instrumentation is also generally installed during facility expansion. This instrumentation may include survey monuments, piezometers, weirs, and other devices, as discussed in Chapter 13. Important observations to be recorded may include: instrument type, material, make and model; installation details (materials, dimensions); the results of initial calibration and verification of function; and the results of periodic testing to verify continued performance. Maintenance should also be regularly performed as required by the type of instrument ([Section 13.5](#)). For example, periodic flushing of piezometers, if subject to fines accumulation, and regular cleaning of weir boxes are important.

Instruments need to be read in a consistent fashion such that the results are not affected by the individual taking the reading and are directly comparable. If necessary, specific instructions should be provided relative to collecting and recording instrumentation data.

12.1.2.2.6 Reclamation

Any areas that are covered with soil and/or vegetated should be noted by location and include a description of the work undertaken. Where areas are covered, the source of the soil or topsoil,

the thickness of the cover, and the method used to place and/or compact the material should be noted. Where areas are vegetated, the type of seeding used, the method of placing the seeding, any amendments added, and procedures used to protect the vegetation, such as mulch or straw should be noted.

12.1.2.3 Adjoining Area Conditions

Areas adjoining a refuse disposal embankment include downstream areas, embankment abutments and upstream areas. Each of these areas should be carefully observed for the presence of conditions that could impact embankment stability, such as concentrated seepage, and other aspects of facility operation and safety, as discussed in the following subsections.

12.1.2.3.1 Sloughing or Sliding

Stability of an embankment is dependent not only upon conditions within the embankment itself, but also upon the embankment foundation materials. Therefore, areas immediately upstream and downstream from any embankment should be inspected for bulging conditions, open cracks with vertical displacement or other signs, such as the orientation of cracks, that could indicate movement of the soil or rock materials is occurring. In wooded areas, a possible means of identifying the presence of such conditions is to observe the trunks of the trees to determine if a group of trees has an unusual inclination. If such signs are evident immediately adjacent to an embankment, the embankment surface should be examined very carefully to see if the movement has extended into the embankment.

12.1.2.3.2 Signs of Subsidence

Evidence of mine subsidence can include surface cracks (particularly when oriented with mine workings and/or vertical displacement), depressions, and sinkholes. Often evidence of subsidence due to underground mining is more readily apparent on natural ground surfaces than on an embankment surface, because the embankment can arch over a subsided area for some period of time or the subsidence features can be hidden by disposal operation. Subsidence that occurs on the natural landform can cause rapid changes in contours where bedrock is shallow or sinkhole development where water washes material into the mine. Also, in areas where subsidence is not uniform, the inclinations of tree trunks can vary significantly over short distances. If possible signs of subsidence are observed, mine maps should be reviewed to determine if there are mine works present that could be causing the problem. Subsidence may also occur over mines that are unmapped or incompletely or inaccurately mapped. In many cases, small punch mines have been developed for residential coal consumption and may not be mapped, as is done for commercial coal mines. The lack of availability of maps should not be considered as evidence of the absence of underground mines.

12.1.2.3.3 Evidence of Erosion

Conditions where erosion of the natural ground surface occurs downstream or downslope from an embankment, or erosion of the embankment itself, can be critical and includes cases where: (1) an adjacent stream rises during a flood causing erosion of the embankment toe or (2) the drainage system from areas upstream of the embankment discharges onto or immediately adjacent to the embankment causing downcutting and eventual instability. The locations of any areas of significant increase in erosion of the embankment or the adjacent ground surface should be noted.

12.1.2.3.4 Springs or Seepage Areas

Instability of an embankment slope due to high pore-water pressures or piping of soil materials can occur in the embankment foundation and abutments as well as on the downstream face of the embankment. Therefore, it is important to observe the downstream slope and area downstream from the abutments and toe of an embankment and to note development of new seepage areas or changes in areas where seepage was previously occurring. In particular, it should be deter-

mined whether existing seepage zones have increased in flow volume since the last observation and whether the seepage is carrying fines, which is an indication of internal erosion.

The presence of “boils” (points where a concentrated upwelling of seepage is creating a deposit of fine material) is an especially important indicator of internal erosion. Records of spring and seepage area flow volume should be kept for comparison purposes. Significant changes in seepage or evidence of internal erosion should be brought to the attention of the Engineer, because corrective measures to prevent instability, progressive internal erosion, or piping may be warranted. Seepage and water quality monitoring (e.g., temperature, turbidity, and total dissolved solids) and interpretation of trends are discussed in Pelton (2000).

12.1.2.3.5 Changes in Vegetation

As noted previously, changes in the inclination of tree trunks can indicate sliding and sloughing of the natural ground materials or subsidence due to underground mining. Also, areas that have either an abnormal amount of dying vegetation or unusually dense vegetation may indicate the presence of seepage zones that are not immediately evident at the ground surface.

12.1.2.4 Other Development Work

12.1.2.4.1 Upstream Development

Any changes in the watershed area above the facility, such as tree cutting, strip mining, and residential or industrial development should be noted, since these activities could affect runoff flows to the site. Also, these activities may affect the quality of surface water passing through the site, which could mistakenly be attributed to the refuse disposal facility. The location and extent of upstream changes and the nature of such changes should be documented and brought to the attention of the Engineer.

12.1.2.4.2 Downstream Development

Inundation mapping associated with dam breach analysis for establishing the hazard potential classification is based upon topography and stream conditions downstream from the refuse impoundment. Future development in the downstream floodplain could increase the hazard potential rating. Also, a new mine opening or coal preparation plant constructed downstream from the facility spillway might be susceptible to flooding during large storms. Any such change in downstream land use, including the location and description of the change, should be brought to the attention of the Engineer.

12.1.2.4.3 Disposal of Materials Other than Coal Refuse

The design of critical portions of refuse disposal facilities is typically based on the assumption that uniform materials will be used. The use of materials from other sources (e.g., power plant waste) or from site development work unrelated to the disposal facility, such as placement of coarse-grained rock from slope excavations in the disposal facility embankment, could cause undesirable behavior and should not be permitted unless specifically allowed in the approved design plan. Material that could lead to combustion in the coal refuse embankment is not permitted.

12.1.2.5 Refuse Disposal Operations and Maintenance

12.1.2.5.1 Refuse Placement and Compaction

Disposal operations comprise the placement of refuse materials within embankments in accordance with the plans and specifications. Important observations to be documented include: materials (gradation and moisture), delivery to site and spreading (location and equipment), lift thickness, compaction (equipment, number of passes), surface conditions (firm, pumping), surface preparation or scarifying (method or equipment, extent and frequency), and benching of new lifts into embankment and abutment materials (dimensions and extent). During inclement weather, it can be difficult

to meet construction specifications for refuse placement and compaction, particularly in structural zones, and documentation of potential problem areas is important to the planning of future actions. Where feasible and appropriate, other zones or areas that can accommodate coal refuse where placement standards are lower, such as during inclement weather, may be provided as part of the design. Monitoring and inspection of these areas typically include observation of lift thickness, grading, access, and drainage control.

12.1.2.5.2 Working Surface Maintenance

The working surface where active refuse disposal is taking place should be maintained consistent with the plans and specifications and with careful control of drainage. Observations should include: (1) survey control such as stakes or markers to define placement limits and grades, (2) lift placement and compaction, (3) scarification of the surface of layers that are too smooth to properly bond to the next layer, and (4) drainage control measures for directing water away from active placement areas and toward collection ditches. Density and moisture content testing must be fully documented including the location of the tests (which should generally be random or focused on areas of suspect compaction), the lift thickness, and the test results. Compaction conditions should be further evaluated if the test results show that the compaction specifications are being met, but the lift surfaces after compaction remain soft or spongy. If the compaction specifications are not met, then additional compaction will be required and, if this situation occurs frequently, the cause should be determined.

Adequate compaction requires the proper lift thickness and number of passes of the compaction equipment be used. The type and number of passes required for achieving the minimum compaction specifications will depend on the compaction equipment and lift thickness. When new or different compaction equipment is used, the number of passes needed to meet the compaction specifications needs to be established by a coordinated program of field density testing. The compaction operation should be observed to verify that lifts are being systematically compacted at the proper thickness with overlapping passes of the compaction equipment.

12.1.2.5.3 Embankment Crest Conditions

The crest of a refuse embankment should be constructed and maintained in conformance with the facility plans and specifications and should be generally level (or with a slight slope towards the impoundment) to provide adequate freeboard and drainage control. Important observations include: (1) alignment and level, (2) indications of movement (e.g., cracks, sloughs, scarps), and (3) abutment interface (including benching to tie refuse materials into natural hillsides, control of drainage from hillsides, and control of erosion).

Coal refuse tends to break down when exposed to the elements and to equipment traffic. When a crest elevation is maintained for a period of time, a layer of highly compacted and weathered material may be present at the surface. Prior to raising the crest, this material should be disturbed by thorough scarification or should be removed so that it does not create a continuous horizontal layer of low hydraulic conductivity within the embankment. Such a layer can cause elevated seepage levels in the embankment and defeat the purpose of internal drainage measures.

12.1.2.5.4 Embankment Slope Conditions

The slopes of a refuse embankment should be developed and maintained in conformance with the facility plans and specifications. Temporary slopes should be consistent with the geometry and overall development shown in the design report. Documentation should include alignment and steepness, seepage, movement, and erosion. The following conditions should be noted, as applicable:

- Sloughing and sliding – All embankment slopes should be carefully inspected for the possible presence of sloughing and/or sliding. Such conditions are usually accom-

panied by bulging at or along the bottom of the distressed area and possibly the formation of a vertical displacement (scarp) and cracking at or along the top of the distressed area. Special care is required in areas of heavy vegetation to avoid overlooking these areas of distress. Heavy vegetation that hampers inspection activities should be cut or removed, as should any trees that begin to grow on the embankment. Particular attention should be paid to the downstream slope of an impounding embankment. Any signs of sliding or sloughing should be reported immediately to the Engineer and Operator.

- Subsidence – Subsidence of an embankment can occur as a result of three conditions: (1) the collapse of voids in the embankment or foundation that form due to piping, when seepage flows remove particles of refuse or soil, (2) consolidation of soft foundation or embankment materials, and (3) collapse of mine workings. Subsidence due to piping can usually be recognized by the presence of localized bowl-shaped depressions at the surface. Subsidence due to settlement of soft foundation materials usually results in low areas on the embankment surface and occasionally cracks. Subsidence due to underground mining can be identified by cracking along straight lines, typically parallel to the primary direction of mining, or as deep circular sink holes. When vegetation is tall, care should be taken to avoid overlooking such signs of distress. If subsidence is discovered, the size, shape and extent of the distress should be determined and recorded. Any evidence of subsidence should be reported immediately to the Engineer and Operator.
- Erosion – Erosion is loss of ground cover caused by a lack of proper drainage control. Sheet erosion is a surficial loss of soil or refuse in a more or less uniform pattern extending over wide areas. Gully erosion is the result of concentrated overland flow and leads to the creation of narrow and possibly deep channels in the ground surface. Any occurrence of erosion should be documented as to type, location, and extent. Erosion should be corrected when it starts to develop and before it becomes significant. Erosion that has progressed to deep gullies can affect seepage and stability and is much more difficult to correct. If erosion is found to concentrate or recur in particular areas, consideration should be given to improving surface drainage in those areas.
- Moisture conditions, springs, seeps and wet areas – Slopes should be monitored for the presence of springs, seeps and wet or boggy areas. Evidence of such conditions includes the presence of unusually wet and/or soft areas and areas where snow melts rapidly in the winter. Also, vegetation may be thriving due to the moist conditions, leading to unusually dense and taller growth as compared to surrounding vegetation, or vegetation may be adversely affected by acidic seepage and may be discolored or dying. The location and the extent of such conditions should be documented. If actual flow is observed, the rate of flow should be measured or estimated, and the quantity and character of any suspended solids (silt, sand, etc.) carried by flow should be noted. The Engineer and Operator should be notified immediately. The flow should be measured regularly, and the records should be maintained for comparison purposes. Particular attention should be paid to the downstream face of impounding embankments, as springs, seeps and wet areas can lead to sloughing and sliding.
- Condition of vegetation – All seeded areas should have a well-developed vegetation cover. The vegetation should be uniform and continuous. Any irregularities such as difference in color, density, rate of growth, type of growth, or a difference in the character of the vegetation should be noted. For example, cattails are a common indicator

of wet areas. Such irregularities could be evidence of other problems. The location and nature of any irregularities in vegetation should be recorded.

- Trees – The roots of trees can provide paths for seepage and, if the roots decay, voids may be created. Trees that are blown over during a storm can also damage an embankment. For these reasons, trees should not be permitted to become established on the crest or slopes of a refuse embankment. Guidance on maintenance of vegetation and embankment repair following removal of trees is presented in Marks and Tschantz (2002).

12.1.2.5.5 Liner, Foundation and Abutment Conditions

Liner, foundation and abutment conditions should be observed for signs of deterioration, inadequate drainage control, erosion or instability prior to placement of refuse. Along rock abutments, rock overhangs should be removed so that fill can be adequately compacted against the abutment. The treatment of open discontinuities in the foundation/abutments should be addressed in the specifications. If such foundation features are observed and are not addressed in the specifications, they should immediately be brought to the attention of the Engineer.

12.1.2.5.6 Internal Drains

The outlets of internal drains should be observed to: (1) determine discharge rate and clarity, (2) verify that no blockage restricting discharge is present, and (3) verify that drainage is directed away from the outlet and not backing up into the drain. In addition to this monitoring, flow rates should be measured, recorded, plotted, and regularly reviewed by the Engineer and should be compared to other facility data such as impoundment pool level, rainfall, and the presence or absence of a fine refuse delta.

12.1.2.5.7 Decant Pipe

The inlet of the decant pipe should be observed relative to inflow depth and rate, alignment, presence and condition of a trash rack and anti-vortex plate, and verification that there is no blockage by debris. The outlet of the decant pipe should be observed relative to discharge rate and clarity, presence of debris, erosion conditions, seepage along the outside of the pipe, and verification that the discharge is directed away from the outlet without backup into the pipe. Where exposed, the pipe wall should be observed for distress. The first time that decants flow and when they are subject to significant increases in head are important times to observe performance for possible indications of problems. During decant pipe observations, or as part of scheduled inspections, the following should be evaluated:

- Clogging – A common mode of failure of decant systems that is very difficult to correct is clogging of the intake or pipe with miscellaneous debris. Most designs include a trash rack around the intake to block material that cannot easily be carried through the pipe. The buildup of debris on and adjacent to the trash rack should be cleared, and the removal should be documented. Proper equipment and access should be provided so that any debris can be safely removed. Any damage to the trash rack or the presence of debris that cannot easily be removed from the intake should be reported.
- Characteristics of discharge – Where possible, an evaluation should be made of the character and volume of water flowing into the decant inlet and out of the decant discharge. If the appearance of the water at these two locations differs, it is possible that cracks or open joints in the decant pipe are allowing seepage flow to enter the pipe or decant flow to exit the pipe. If this situation is observed, it should be reported

immediately to the Engineer. The presence of seepage flowing along the outside of the conduit at the downstream end of the decant should also be noted.

- Corrosion, cracking or crushing – Loss of any portion of the decant system can affect continued operation of a refuse disposal facility. For this reason, areas of distress to the decant system due to corrosion of materials, cracking or crushing should be reported immediately so that appropriate repairs can be made. Special inspection procedures and equipment may be needed for observation of the condition of a buried decant pipe. Typically, a decant should be treated as a confined space and only entered with appropriate precautions, including:
 - Initially checking and then regularly monitoring of the atmosphere inside the conduit for safe conditions and air movement (e.g., a respirable, non-explosive atmosphere).
 - Providing for continuous communications with personnel inside the conduit.
 - Ensuring that personnel entering the conduit have appropriate personal safety equipment.
 - Providing for safe ingress and egress, including harnesses and lifelines where appropriate.
 - Providing workers with training with respect to potential hazards and required safety measures.

Track-mounted video cameras that can travel inside the decant pipe are commonly employed to avoid entry of personnel and in situations where pipe diameters are small. Inside-diameter measurements can be obtained using optical/laser equipment coupled to a track-mounted video camera.

- Erosion conditions – Erosion at the decant intake is not generally important to the integrity of the decant system, but is an indication that fine refuse particles are being transported into the decant pipe. These materials may settle out at low points or bends and eventually reduce the decant pipe capacity. Erosion at the discharge point can be more critical if it eventually undercuts the outlet causing a break in the pipe or undercutting of the toe of the adjacent embankment creating local stability problems. Seepage discharging along the exterior of the decant should be noted and observed for evidence of fines carried with the flow (an indication of internal erosion along the conduit). Any of these conditions should be reported to the Engineer and Operator.

12.1.2.5.8 Channel Conditions

Observation of channels associated with spillways, ditches and gutters should include: (1) alignment and dimensions (depth, width and side slopes), (2) evidence of debris, (3) erosion and condition of erosion protection, and (4) the condition of receiving channels, ponds, or streams. The following observations should be documented:

- Erosion – The banks and the beds of all channels should be examined to determine if erosion or siltation is occurring. Channels should have a uniform configuration consistent with construction plans. Erosion of banks is evidenced by side slopes that are steeper than shown on the plans or by sloughing or localized irregularities in configuration. The location of any eroded areas should be recorded. The location of the spillway discharge should be checked to see that it is far enough downstream that the embankment toe is not being eroded.

- Undergrowth – The channel cross section should be clear of undergrowth such as brush and small trees from the top of one bank to the top of the opposite bank. Such undergrowth decreases the efficiency of the channel and traps floating debris during high flows. Areas of excessive undergrowth should be cleared.
- Flow obstructions – Any obstructions to flow in a channel such as fallen trees, sloughed-in soil or rock from adjacent excavated slopes, or other foreign objects or excessive vegetative growth should be noted and removed at first opportunity. Where significant sloughing of a channel slope is occurring, engineering personnel should be notified immediately.
- Structure conditions – The condition of all structures that are part of, or appurtenant to, the channels should be noted, including culverts, retaining walls, wing walls, rock cuts, pavements, slabs, etc. Culverts should be maintained in good condition, free of debris and with unobstructed inlets and outlets. Walls, slabs, rock cuts and pavements should be checked for evidence of distress such as settlement or other movements, cracks, scour and erosion. All areas requiring improvement or maintenance should be documented.

Riprap is commonly used in channels and elsewhere for erosion protection. Observations of riprap should include the following:

- Irregularities and displacements – The surface of riprap areas should be examined for abrupt changes in slope or alignment and for gaps or cracks in the surface. Areas where the riprap is missing or has otherwise been disturbed should be noted. Localized changes in the character of the riprap material should also be recorded. If the deterioration of riprap is extensive, the Engineer and Operator should be notified.
- Sizes – The maximum and minimum sizes of the riprap should be examined to verify that they are generally in accordance with the plans and specifications. The distribution of riprap sizes should be uniform. Any observed segregation of riprap with respect to size should be noted. Irregularities in the size of the riprap could indicate that deterioration due to weathering or scouring is occurring.
- Weathering – Weathering is the deterioration of the riprap due to freezing and thawing cycles or due to chemical action in the presence of water, air, sunlight, etc. Weathering of riprap is usually indicated by a lack of larger-sized pieces, since weathering acts to break the larger pieces into smaller ones. If weathering of the riprap has occurred, the location and extent of the weathering and the largest remaining size should be recorded.
- Scouring – Scouring of riprap is caused by the effects of flowing water or wave action. The mechanical action of the water acts to segregate the riprap and carry smaller-sized pieces away. Scouring is usually indicated by a lack of smaller pieces. If scouring has occurred, the location and extent of the scouring and the size of the smallest remaining pieces should be recorded.
- Grouted riprap – At some locations, the riprap surface may be grouted to a certain depth with fine aggregate concrete. Disturbances to the riprap, such as settlement, undermining, erosion and scour can cause deterioration of the concrete grout. Any areas where the concrete grout has deteriorated, or areas where it is missing entirely, should be recorded.

Concrete is frequently used in the construction of spillways, channels and other hydraulic appurtenances. Distress to concrete structures can result from many factors ranging from simple deteriora-

tion with time to movements of the structure foundation. Since the type of repair is dependent upon the cause, observed conditions should be recorded so that appropriate repair and maintenance procedures can be implemented.

- Cracking – The surface of all concrete structures and other concrete appurtenances should be inspected for the presence of cracks. Care should be taken to not overlook hairline crack patterns. The size, location and configuration of observed cracks should be recorded. If cracks are noted on a particular structure, other similar parts of the same structure should be carefully examined.
- Spalling – The surface of all concrete structures and other concrete appurtenances should be examined for the presence of spalling. Spalling is indicated by the removal of the concrete matrix at the surface. The remaining surface texture will be rough, and the aggregate will be exposed. In general, two types of spalling can occur. The first is a surficial or uniform deterioration of the concrete surface. The second type is a deep spalling that exposes the reinforcing bars. If spalling is observed, the type should be noted, and the location and the extent of all spalled surfaces should be recorded.
- Condition of joints – All construction joints, expansion joints and contraction joints should be examined to determine if relative movement at the joints has occurred. If there is evidence of movement at any joint, the size and uniformity of the gap should be noted. Variation in size and width of the gap may indicate the relative movement of the structure, and observation of changes in the condition with time will indicate if further movement can be expected.
- Leaks and seepage – All drains and weep holes in concrete structures should be examined to verify that they are free from debris and are functional. Often water flowing through improperly functioning drains and weep holes will wash backfill material or filter material from behind a wall and deposit it in front of a weep hole. If this condition is observed, it should be noted. All concrete surfaces should be examined for the presence of damp or wet surface areas. If damp or wet surface areas are found, their size, extent and location should be noted. Any water seeping from cracks or joints in any concrete structure should be noted.
- Settlement or heave – The vertical alignment of all concrete structures should be checked for irregularities. This can best be accomplished by sighting along horizontal lines of the structure. All structural lines should be straight. Settlement is indicated by a dip or depression. Heave is indicated by an elevated section or hump. If settlement or heave occurs over a substantial distance, it may be difficult to detect. Such large-scale movements are normally associated with relative movement at one or more of the joints in the structure. If it is expected that settlement or heave is occurring over an extended distance, the condition of the joints in the structure should be carefully observed to determine where the movement is occurring. The location of and an estimate of the magnitude of any settlement or heave should be recorded.
- Deflection and lateral movements – The horizontal alignment of all concrete structures should be checked for irregularities. This can best be accomplished by sighting along vertical lines of the structure. All vertical lines should be plumb. Localized lateral movements will be indicated by bulges in the walls and/or misalignment of the structural elements. Relative displacement at the vertical joints may also occur. If such displacements are observed, the location and an estimate of the magnitude of displacement should be recorded.
- Tilting – Tilting is indicated by general rotation of a structural element. Tilting may often be combined with settlement or lateral movement. If tilting occurs, vertical ele-

ments such as walls will be out of plumb and horizontal elements such as slabs will be out of level. Such a condition is probably most easily detected by viewing the structure from a distance. Tilting of water conveying channels is indicated by a tendency for the depth of flow to be greater at one side of a channel. Tilting of structures such as retaining walls and chute walls may be accompanied by a gap between the structure and backfill. Periodic surveying should be performed when tilt or movement is suspected.

- **Undermining** – Concentration of rainfall runoff along, around and behind concrete structures can cause erosion that can lead to undermining. This is particularly relevant for paved gutters and channels. Major seepage or leaks under or behind concrete structures can also cause undermining. Undermining may be indicated by holes or voids under or behind the structures or by localized settlements or depressed areas on the surface of the backfill around them. Care should be taken not to miss evidence of undermining that may be obscured by vegetation.
- **Condition of backfill** – The condition of the backfill around and behind all concrete structures should be examined for evidence of erosion, settlement and/or lateral movement. If the backfill was seeded, the condition of the vegetation should be noted. The surface of the backfill should be examined for the presence of depressions or small holes. Lateral movement of the backfill may be accompanied by a gap between the concrete structure and the soil, cracks in the surface of the backfill running generally parallel to the main lines of the concrete structure, or vertical steps or scarps in the surface of the backfill. Particular attention should be paid to backfill along and behind spillway chute walls.

12.1.2.5.9 Instrumentation

The overall condition of instrumentation such as flow monitoring weirs, survey monuments and piezometers should be determined by visual inspection. For example, weirs should be inspected to verify that they are in good condition and that erosion has not created bypass channels; survey monuments should be observed to verify that they are still in place and in good condition; and piezometers should be checked to verify that they are in good physical condition and operable. Observed damage to instrumentation should be immediately reported to the Engineer and Operator and the instrumentation should be repaired or replaced as necessary. Malfunctioning or damaged instrumentation needs to be repaired or replaced, unless there is a technical basis for its complete elimination. Instrumentation that is included in the construction plans and specifications should be maintained unless removal is approved by the appropriate regulatory agencies. Should supplemental instrumentation be recommended by the Engineer or implemented by the Operator, the purpose and planned frequency and duration of monitoring should be documented and submitted to MSHA.

12.1.2.5.10 Reclaimed Slopes

Slopes and other completed surfaces that have been reclaimed should be observed with respect to movement, vegetation development, drainage control, erosion and seepage. In addition to safety of the refuse disposal facility, they are important with respect to abandonment of the facility and environmental control. A primary reason for noting conditions in these areas is to verify that the type of covering and vegetation procedures being used are adequate and will result in the desired finished embankment. Observations should include: (1) notation of the uniformity of vegetation, (2) areas where the vegetation cover is apparently not surviving or is very sparse, and (3) areas where cracking or erosion of the soil cover is affecting its function of protecting the embankment or other surface.

12.1.3 Quality Control Sampling and Testing

In addition to visual observation, field quality control sampling and testing provides a means to verify that construction of refuse disposal facility components is being performed in conformance

with the plans and specifications. Table 12.2 presents a summary of typical quality control tests and guidelines for testing frequency associated with refuse disposal facility construction. Designers may wish to incorporate alternate testing requirements and/or frequencies to reflect site- or design-specific facility conditions. For example, more tests may be performed initially to establish the variability of properties.

12.2 MONITORING INSTRUMENTATION

Measurements should be routinely recorded as part of the monitoring and inspection program for each coal refuse disposal facility. Most instruments that require monitoring are specified and installed as part of the normal design and operation of the refuse disposal facility. Supplemental instrumentation may be installed in response to unexpected conditions. The exact types and location of instruments should be specified in the plans and specifications and the Operation and Maintenance Plan for the facility. For most facilities, monitoring instruments typically include survey monuments, piezometers, monitoring wells, and weirs or flumes. A method for monitoring the pool/slurry level is usually also provided. More complex instruments are sometimes required during construction and operation of a coal refuse disposal facility for monitoring and more closely observing selected areas or conditions. A thorough discussion of coal refuse facility instrumentation is provided in Chapter 13. A brief summary of typical instrumentation at coal refuse disposal facilities is provided in the following paragraphs:

- Monument surveys– The use of monument surveys along with as-built topographic surveys based on aerial photography is an effective method for monitoring both displacements and configuration of the facility. Monument surveys can detect both horizontal and vertical movement of an embankment, and it is recommended that an active facility should be surveyed by a licensed surveyor at least annually. Annual as-built topographic surveys provide an effective basis for verifying that construction is progressing in accordance with the design plans and for preparing reports to regulatory agencies concerning the amount and extent of construction. They also provide a means of confirming refuse production rates and progress on individual embankment stages. More frequent as-built surveys for facilities during initial development may be important for verification that critical embankment heights and geometries are being achieved. Both monument surveys and as-built topographic surveys are limited in their accuracy, and smaller movements may not be detected. If displacements are suspected, additional instrumentation may be needed.
- Pool-level gauge – For slurry impoundments, a method is needed to monitor the level of the pool and the slurry delta. This information is needed in order to verify that the design provides adequate freeboard and slurry disposal capacity. The pool level can be determined based on visual observations at a staff gauge and delta monitoring conducted by periodic elevation surveys relative to established benchmarks near the upstream slope of the refuse embankment. Also, soundings can be performed to determine settled fine refuse levels within the pool area.
- Rainfall gauge – A rainfall gauge should be located close to an impounding refuse embankment so that daily precipitation can be monitored and compared to piezometer records or seepage rates observed at weirs. This is particularly important where underground mine workings are close to an impoundment and monitoring of mine discharge is being performed. In such cases, rain gauge data allow increases in mine discharge due to rainfall to be distinguished from increases caused by impoundment seepage or leakage.
- Piezometers – Piezometers are normally installed at impounding facilities for monitoring the phreatic level or pore pressures in a refuse embankment for comparison

to projected design levels used in stability analyses. Piezometers are also used for monitoring pore pressures during upstream embankment construction. Tolerable excess pore pressures predicted in the design can then be compared with monitored pore pressures. The three most commonly installed types of piezometers are stand-pipe, pneumatic and vibrating-wire. Chapter 13 provides a detailed discussion of these types of piezometers, along with others less commonly used. Consistent with CFR § 77.216-3, instruments should be measured/read every seven days and the data should be recorded. The actual frequency of measurement should also be based on the historical or expected rate of change in pore pressure and the disposal facility design features. More frequent piezometer readings are generally obtained during upstream embankment construction. Automated data acquisition systems coupled with vibrating wire piezometers have been used at refuse facilities to obtain more frequent pore pressure measurements; such systems are also employed because of their cost savings.

- Monitoring wells – Monitoring wells, and to a lesser extent piezometers, are used for monitoring the groundwater quality and levels at and adjacent to refuse disposal facilities. The monitoring or sampling frequency varies depending upon environmental conditions and state regulations.
- Weirs and flumes – Weirs and flumes are used to measure water flow rates in channels and from seeps and internal drains. The monitoring and measurement of flow rates from seeps and internal drains is an important means for evaluating the performance of the internal drainage system of an impounding refuse embankment. At sites with underground mining, flow from mine openings may also be measured as a means for monitoring changes in the amount of seepage into the mine, and these data may provide an indication of the performance of the impoundment with respect to potential breakthrough, provided that surface runoff is diverted away from the weir. Accurate measurement of weir flow rates is important, and the frequency and methods of measurement should be specified in the plans and specifications and the Operation and Maintenance Plan. Flow rates are typically measured on a 7-day basis and recorded, or less frequently if records indicate consistent measurements and conditions permit (consistent with the regulations and approved plan). If flow rates are relatively low, they can be measured using a standard bucket or calibrated container and stop watch. The time required for the water flow to fill the container is recorded, and a flow rate is calculated. Evaluation of flow data to determine whether they are normal or unusual will typically require correlations with pool level and rainfall. Flow-related data should be plotted on a common time-line, along with pool and piezometer data, so that trends in the data can be identified and flow trends can be evaluated to verify that they are consistent with expectations. To accurately correlate seepage flows with rainfall, measurements may need to be performed on a daily basis.
- Blast/vibration monitoring – Drilling and blasting activities can cause shock vibrations that can affect a structural component of a refuse disposal facility or cause displacements due to liquefaction of embankment foundation materials. Common instruments for monitoring shock vibrations are commonly referred to as accelerometers or velocity transducers. The determination of the equipment needed for vibration measurement requires the input of an experienced engineer who is familiar with the field data needed for analysis of the possible effects of vibration and dynamic displacement on facility components.
- Conduit monitoring – Deeply buried conduits may require monitoring during the life of the facility. Small video cameras mounted on a mobile unit that can travel through the conduits are commonly used to inspect the interior condition. Measurements of

deflection can be obtained with various measuring devices such as laser or optical equipment using the laser ring method. This method employs a non-contact laser that is projected onto the interior of the pipe and viewed by a video camera. Software is then used to calculate the interior dimensions of the pipe. The need and frequency of conduit monitoring is a function of the pipe design (including tolerable deformations) and site-specific parameters such as foundation conditions, depth of cover, observed performance, conduit extension schedule, and other aspects of the facility.

- Extensometers/settlement gauges/inclinometers – These instruments, as described in Chapter 13, may be used where there is potential for deformation of the foundation or abutment, particularly where mine subsidence is present. The need and frequency of monitoring of these instruments should be determined on a site-specific basis, and often is related to performance monitoring of other instruments such as surface monuments.
- Temperatures – If necessary, instrumentation can be installed in a coal refuse embankment to monitor the internal temperature. Temperature monitoring instruments vary from conventional thermometers to telethermometers. Telethermometers are sometimes coupled with a vibrating wire piezometer in automated data collection systems.

Instrumentation data and measurements discussed above should be regularly reviewed and should become part of the annual dam safety inspection report required by some states and the Annual Report and Certification required by MSHA.

12.3 FACILITY AND DAM SAFETY INSPECTIONS

Facility and dam safety inspections provide a basis for identifying maintenance needs, for evaluating conformance of refuse disposal facilities with the plans and specifications developed for their construction, and for detecting signs of instability or other safety-related problems with the performance of the facility. It is recommended that impounding facilities have in place dam safety inspection programs including: (1) routine dam surveillance by the facility operator, (2) dam safety inspection by the Engineer, and (3) dam safety review (including evaluation of continued disposal facility development requirements) by an engineering team (Szymanski, 1999). Routine embankment surveillance should be consistent with the 7-day impoundment inspection requirement by MSHA. Dam safety inspections should be conducted by, or under the guidance of, the Engineer and should include at least annual inspections for evaluation of the condition of the facility and may also include routine inspections that supplement dam surveillance. Dam safety review includes a more comprehensive inspection and evaluation of future refuse production and disposal plans that typically is performed as part of stage completion and initiation of new disposal facility stages.

12.3.1 Routine Inspections

The qualifications of inspection personnel and the frequency of facility inspections are related to the type and design of the refuse disposal facility and federal and state regulatory requirements. Inspection records should be maintained for future reference. Each inspection should involve the review of data collected from previous inspections and from construction monitoring activities since the previous inspection. Routine inspections are typically performed on a weekly to quarterly basis or as specified in the Operation and Maintenance Plan.

12.3.1.1 Impoundments and Dams

MSHA requires inspections (at intervals not to exceed 7 days or as otherwise approved by the MSHA District Manager) of impoundments in accordance with CFR § 77.216-3 and provides guidance for these inspections in the *MSHA Coal Mine Impoundment Inspection and Plan Review Handbook* (MSHA,

TABLE 12.2 FIELD QUALITY CONTROL TESTING SUMMARY

Item	Test	Suggested Frequency	Reference	
Topsoil/Subsoil for Reclamation				
Material Composition	Nutrients, organic matter	Each area or as required by state regulatory agency		
Foundation Preparation				
<u>Foundation Soils</u>				
Suitable Material	Proof-rolling and/or field density and moisture (strength and gradation on suspect material)	> 1 test per foundation material type	USBR, 1998	
<u>Cutoff/Key Backfill</u>				
Suitable Material	Index properties, hydrometer, standard proctor, (hydraulic conductivity, if part of liner)	> 1 test per 20,000 cy		
Compaction	Compaction	> 1 test per 2,000 cy		
<u>Underdrain</u>				
Suitable Material	Gradation, durability	> 1 test per material source		
Liner Construction				
<u>Soil</u>				
Suitable Material	Sieve analysis, index properties, hydrometer, standard proctor, hydraulic conductivity	> 1 test per lift per acre and as material varies or as required by state regulatory agencies	USBR, 1998	
Compaction	Compaction	> 1 test per 2,000 cy or each lift		
<u>Geosynthetic</u>				
Geomembrane	Strength at seams	6 per 3,300 feet of seam, if sampled randomly, or 1 every 500 feet of seam, if sampled on a uniform basis	Haxo, 1986 Daniel and Koerner, 1995 GRI, 2005	
Geosynthetic Clay	Clay mass, strength, index flux	> 1 test per material source		
Structural Fill Placement				
Material	Index properties, sieve analysis	Each material and > 1 test per 20,000 cy	MSHA, 2007	
	Compaction (embankment fill)	≥ 1 test per 2,000 cy (at least 1 test per lift)		
Compaction	Compaction (backfill around structures)	≥ 1 test per 200 cy (at least 1 test per lift)		
	Proctor	Each material and > 1 test per 20 field compaction density tests		

TABLE 12.2 FIELD QUALITY CONTROL TESTING SUMMARY
(Continued)

Item	Test	Suggested Frequency	Reference
Placed Refuse Fill⁽¹⁾			
Material	Index properties and sieve analysis	As material varies	
Compaction	Compaction	Dependent on facility design	
Internal Drain			
<u>Aggregate</u>			
Suitable Material	Gradation and durability, calcium carbonate	> 1 test per material source	
<u>Geotextile</u>			
Material	Permittivity, strength	> 1 test per material type	
Decant Pipe			
Material Connections	Leak (pressure) testing	Completed sections or entire length	
Bedding and Backfill Material			
1. CLSM or Concrete	Strength, air content, temperature, slump, and potentially hydraulic conductivity.	1. Each pour	
2. Soil	Index properties, hydraulic conductivity (if penetrating liner), proctor compaction	2. Each material; >> 1 compaction test per 200 cy (min. 1 test per lift)	
Operational Performance or Long-Term Performance	Camera survey with deflection measurements	With major increase in embankment height for flexible pipe, depending on pipe design for deflection and strength ⁽²⁾	
Channels			
Riprap Material ⁽³⁾	Gradation and durability	Each material	
Grout Material	Strength, slump	Each pour	
Concrete ⁽³⁾	Strength, air content, temperature and slump	Each pour	
Soil Backfill Material	Index properties, proctor compaction, compaction	Each material > 1 test per backfill segment	
Reclaimed Slope			
Soil and Topsoil Material	Thickness, nutrients	Each material or as required by appropriate state regulatory agency	

Note: 1. "Placed refuse fill" may be designed zones where material placement and compaction standards are typically lower than for structural fill.

2. A baseline camera and deflection survey may need to be performed upon completion of backfill and cover for flexible pipe installations, depending on the pipe design.

3. Aggregate subbase and/or geotextile filter may be subject to similar testing as for an internal drain.

2007). The 7-day inspection requirement normally applies to impoundments that are classified as having high or significant hazard potential; sites with low-hazard-potential impoundments may be inspected on a less frequent schedule, if approved by the MSHA District Manager. Personnel who perform these inspections are required to: (1) have current MSHA training, (2) complete inspection forms for documentation, and (3) maintain a record of the inspections. It is recommended that 7-day inspections be supplemented by periodic inspections by engineering professionals (engineers or experienced technicians familiar with the design and construction requirements of the disposal facility and the purpose and function of the instrumentation). The periodic inspections should be documented in reports that are retained for reference. These engineering inspections and associated reports may also be used for periodic certification of stage construction by a registered Professional Engineer, as required by federal and state regulatory agencies. Monitoring data, such as seepage rates and piezometer levels, which are collected during 7-day inspections, need to be routinely reviewed by engineering personnel familiar with the design of the facility to verify that the facility is performing as designed. If monitoring data suggest that the facility is not performing adequately, the observed conditions should be investigated, and the Engineer should be advised and consulted.

12.3.1.2 Non-Impounding Facilities

Non-impounding coal refuse disposal facilities should be inspected periodically in compliance with the Operation and Maintenance Plan and as required by state permits (e.g., monthly and quarterly). In addition to specific permit requirements, these inspections should cover diversion and perimeter ditches, haul roads and gutters, benches and gutters, disposal work surfaces and embankment slopes, refuse compaction, reclaimed surfaces and slopes, instrumentation, etc.

12.3.2 Event-Related Inspections

Inspections of impounding facilities should be performed after events that may have negatively impacted the integrity of the impounding embankment. Examples of such events include mining subsidence, severe storm events, prolonged periods of cold weather, nearby blasting, earthquakes, sudden increase in pore pressures in the dam, sudden increase or decrease of internal drain flows, and landslides or major sloughing near or on the embankment. The scope of such inspections is dependent upon the nature of the event.

12.3.3 Annual Dam Safety Inspections

It is recommended that a dam safety inspection be performed at least annually by an engineer familiar with the design and construction requirements of the facility (preferably the design engineer). Annual dam safety inspections and a formal report by a registered Professional Engineer are required by some state agencies. Sometimes these inspections can be combined with other site data to satisfy the MSHA annual report and certification requirement. The annual inspection should include a review of critical aspects of the facility (such as the results of a potential failure modes analysis, as discussed in [Section 12.1.1](#), or other issues documented in the Operation and Maintenance Plan) and thorough inspection of the facility including embankments and associated abutments. Plotted instrumentation records and construction data should be reviewed. Preparation of completed embankment cross sections reflecting instrumentation data may be an effective way to evaluate large or complicated geometries and the significance of piezometric levels. A tabulation of other monitoring data collected during the year should be prepared and submitted in the inspection report. Photographs should be taken at specific locations during the inspection and compared to earlier photographs taken from the same locations for evaluation of changes over time. Photographs should also be taken of areas that require repair or other special attention. The following data should be compiled in graphs or drawings:

- Piezometric levels with corresponding pool level elevations
- Internal drain flow rates with corresponding pool level elevations

- Seepage flow rates with corresponding pool level elevations
- Refuse embankment density test results
- As-built conditions based upon most recent survey data
- As-built data and drawings for critical items such internal drains, piezometer, decant pipes and spillways
- Site rainfall and temperature records, if appropriate

A review of upstream and downstream areas should be conducted, and changed conditions that could impact the hydrology and hydraulics of the embankment should be identified. The review of the downstream area should concentrate on identification of new development and/or fills that could impact downstream flood levels in the event of embankment failure (Chapter 14) and the appropriate hazard-potential classification for the site. For instance, a bridge or fill constructed in the downstream floodplain could require a modification to the dam breach analysis to account for the potential channel constrictions.

Upstream areas should be inspected to determine if watershed conditions remain consistent with the design assumptions. If the watershed area has effectively increased or disturbance has increased runoff potential, the storm routing analysis may have to be modified and the embankment configuration possibly adjusted to provide adequate freeboard.

An evaluation based upon the visual observations and review of operating records should be performed with respect to evaluation of the overall condition of the embankment. Should areas require remedial attention, they should be identified along with recommended repairs. Similarly, the Operation and Maintenance Plan should be reviewed and modified as needed.

The annual inspection report is a good place to provide information related to the anticipated life of a refuse disposal facility and to provide an evaluation of whether changes may be needed to meet freeboard requirements. Thus, an analysis of observed coal refuse generation rates and the remaining capacity of the facility should be performed and included in the annual inspection report.

12.4 CERTIFICATION AND CONFORMANCE REPORTING

An annual report that includes a description of changes in the configuration of the impoundment is required under 30 CFR § 77.216-4. As part of the annual report, MSHA requires a certification by a registered Professional Engineer that all construction, operation and maintenance of an impoundment was performed in accordance with the approved plan for the facility. Some state agencies also require certification of construction of refuse disposal facilities for specific periods, structures or stages. The registered Professional Engineer should be familiar with design, construction, operation and maintenance of the structure, including dam safety criteria. The design engineer, if involved in the monitoring and inspection of the refuse disposal facility, may provide support or fulfill the certification responsibility.

Certification is generally performed concurrently with reporting of construction monitoring or inspection and is an expression of the Engineer's professional judgment with respect to the consistency of the completed work relative to the approved design plan. It is recommended that the certification be supported by the results of the monitoring and inspection activities performed in response to the designer's specifications and the Professional Engineer's ongoing guidance, which may include visual observation, testing, and instrumentation measurements. The certification is not a guarantee or warranty of performance of the facility and does not relieve any responsible party's obligation to monitor, inspect, construct or operate the facility in accordance with the design plans or to respond to conditions or situations that may represent a hazard to site personnel, public safety, or the envi-

ronment. It is recommended that the annual report cite the specific scope of activities to which the certification applies and reference (or provide documentation of) the observations, testing, and instrumentation measurements providing support for professional judgments.

When observations, test results or instrumentation readings identify possible deviations from the approved plan, the Engineer should evaluate the situation to determine if there are non-conformances and should implement the actions necessary to address such non-conformances, which should be documented in a report available to the regulatory agencies (e.g., operator's 7-day inspection documentation, other regular inspection report such as monthly or quarterly documentation, or the annual impoundment inspection report). MSHA should be notified immediately in accordance with regulatory requirements (30 CFR § 77.216-3) when a potentially hazardous condition to site personnel or the public develops, or in particular circumstances where the approved disposal plan requires that MSHA or state agencies be notified immediately. The Operation and Maintenance Plan should provide guidance regarding what actions need to be taken when observations, testing or instrumentation measurements identify suspected adverse, potentially hazardous, or unsafe or unacceptable operating conditions. When changes need to be made in the design plans or construction specifications, the modifications should be submitted to regulatory agencies for approval.

12.5 MAINTENANCE

Maintenance of a refuse disposal facility throughout its entire operating life is important for many reasons, including:

- Exposure to weather for long time periods results in the natural deterioration of some components that require periodic repair and maintenance.
- Neglecting to perform minor repair work can result in future major repairs or undiscovered deficiencies leading to major distress.
- A primary aim of design is to eliminate maintenance after abandonment. Regular routine maintenance during the operating life will facilitate abandonment of the facility.

The broad range of conditions that can be found at refuse disposal facilities makes it impractical to present a detailed set of instructions for maintenance and repair of each condition that might arise. Maintenance issues should be addressed in the facility Operation and Maintenance Plan. The checklist presented in [Table 12.1](#) and the related discussion in [Section 12.1](#) can serve as a guide for developing a site-specific Operation and Maintenance Plan. Some general maintenance requirements are discussed briefly in the following paragraphs.

12.5.1 Routine Maintenance

Routine maintenance should be performed on a continuous basis in accordance with the Operation and Maintenance Plan. This typically includes reseeding of disturbed vegetated areas, removal of debris and patching and repair of collection and diversion channels, removal of debris from the critical areas of the facility, and repair and reseeding of eroded areas. Such maintenance should be documented.

Routine maintenance should also include control of vegetation during facility operation. Periodic cutting of vegetation on slopes and toe areas of impoundments is necessary to facilitate dam safety inspections and will aid in preventing the development of heavy brush and trees. Trees should not be allowed to develop on an impounding embankment. Should trees develop and mature, their roots can provide seepage pathways leading to voids upon decay, and in some instances extensive slope repair measures may eventually be required. Guidance related to this issue is presented in Marks and Tschantz (2002).

12.5.2 Maintenance after Unusual Events

Some portions of a coal refuse disposal facility and its appurtenant structures may be disturbed by unusual events such as heavy rainfalls, extremely severe frost periods, or periods of very high winds. If heavy rain is forecast, decants and spillways should be checked to ensure that they are clear of debris. Normally, the bulk of maintenance work after an unusual event is associated with repair of diversion and collection channels, eroded zones, and vegetation. The degree of disturbance can be minimized by a conscientious routine maintenance program that eliminates minor deficiencies that could become weak points during severe weather.

12.5.3 Long-Term Maintenance

The natural deterioration of materials exposed to weather requires that repair work beyond routine maintenance be undertaken from time to time. Such work items can include major repairs to riprap and replacement of concrete linings, valves, trash racks, monitoring instruments, etc. The frequency of this work will depend upon the care taken during the site routine maintenance program and the economics associated with performing numerous smaller maintenance efforts versus less frequent major maintenance. The Operation and Maintenance Plan should provide schedules for all levels of maintenance.

Chapter 13

INSTRUMENTATION AND PERFORMANCE MONITORING

The design of coal refuse disposal facilities is governed by criteria for achieving desired levels of structural, geotechnical and hydraulic performance from initial startup through facility construction and operation to abandonment. To verify that the desired performance levels are being achieved, instrumentation should be installed and regularly monitored. Timely collection and review of instrumentation data can allow performance problems to be detected and addressed before unsafe conditions develop. This chapter discusses the factors that should be considered in planning a site-specific instrumentation program and the types of devices used for monitoring. Supporting discussion regarding the uncertainty associated with instrument measurements and types of instrument transducers and data acquisition systems is presented in [Appendix 13A](#). Data typically monitored and the types of instrumentation most commonly used to monitor embankment performance at coal refuse facilities include:

- Vertical and lateral displacements at the ground surface using surface monuments
- Impoundment pool levels using staff gauges
- Piezometric levels and pore-water pressures in embankments and foundations using standpipe and vibrating-wire piezometers
- Surface water flow primarily from seepage and mine discharges using weirs
- Subsurface vertical and lateral displacements in situations of adverse conditions (e.g., settlement and slope deformation) using extensometers and inclinometers
- Meteorological conditions at or near the facility using weather stations (primarily rainfall gauges)

These and other instrumentation are discussed herein along with the ability to remotely monitor and efficiently process data from instruments.

13.1 INSTRUMENTATION PROGRAM PLANNING

Similar to instrumentation programs for other civil works projects, instrumentation program planning for a coal refuse disposal facility should follow a systematic approach with defined objectives. The process should follow a logical series of steps leading to preparation of construction plans and specifications that prescribe: (1) instrument types and installation methods, (2) performance and maintenance requirements, (3) data acquisition methods, (4) sampling intervals and reporting, and

(5) expected measurement ranges including appropriate action and hazard warning levels. This systematic approach, as defined by Dunnicliff (1997), should follow the steps presented in [Table 13.1](#). The full benefit of an instrumentation program can best be realized if these steps are considered and carefully implemented. In doing so, the following adage by Ralph Peck (1972) can be realized,

“We need to carry out a vast amount of observational work, but what we do should be done for a purpose and done well.”

Monitoring the performance of coal refuse disposal facilities typically involves the measurement of deformations, piezometric levels, impoundment levels, seepage flows, and other site-specific parameters. The steps presented in [Table 13.1](#) provide a rationale for determining the instrumentation and staffing requirements, establishing provisions for instrument maintenance, and identifying the use and benefit of monitoring results. [Table 13.1](#) can be used as a design aid to focus attention on the important parameters and locations to be monitored and to avoid the use of instrumentation that may yield little value. Among the critical steps is No. 2 – defining performance questions that need to be answered. Performance questions arise from project or geotechnical conditions that could lead to instability or non-functionality of portions of the structure. Often, critical performance features such as an internal drain or suspect conditions such as a weak subsurface foundation layer beneath the facility or an observed seepage condition, may play a role. These critical or suspect conditions will then be the focus of performance questions related to instrumentation.

Some performance questions that are typically relevant for coal refuse disposal impoundments are summarized in [Table 13.2](#). While this list includes common questions, each site will undoubtedly have unique features or conditions that may introduce other performance questions. At new facilities, the designer must rely on project information and engineering analyses and judgment to identify performance questions and select instrumentation. At existing facilities, where some performance data are available, the designer may identify suspect conditions such as observed seepage or deformation that may lead to more refined answers to the performance questions.

While impoundments are generally facilities where the consequences of non-performance are great, instrumentation should also be employed at non-impounding embankments and slurry cell facilities. Similar performance questions and suspect conditions should be evaluated as part of the identification of the need for and the types of instrumentation to be employed.

In selecting an instrument to measure a desired parameter within the project setting, consideration should be given to: (1) instrument error and uncertainty, (2) instrument type reliability and survivability relative to its expected application, and (3) possible integration of the instrument into a data acquisition system to facilitate data collection, processing, management and decision making. Discussion of the uncertainty associated with instrument measurements and the types of instrument transducers and data acquisition systems is presented in [Appendix 13A](#).

13.2 MEASUREMENT TECHNIQUES

Instrumentation is typically installed at coal refuse disposal facilities to monitor movements and displacements, piezometric levels and pore-water pressures, and surface- and seepage-water flow and the hydrologic and operational factors that influence these flows. Instruments may also be installed to monitor miscellaneous factors such as soil pressure, vibration and shock, and internal temperatures. The following subsections discuss the significance of these measurements and instrumentation that can be used to provide the required data.

Selection of appropriate instrumentation depends on a variety of factors discussed in the previous sections of this chapter. In addition, instrument selection relates to whether performance monitoring

TABLE 13.1 INSTRUMENTATION PLANNING AND DESIGN STEPS

Step 1	Define project conditions and mechanisms that control expected behavior including subsurface conditions and stratigraphy, engineering properties of subsurface soil, rock and groundwater, environmental conditions and other factors that may affect the planned construction.
Step 2	Define the performance questions that need to be answered. For a coal refuse facility these might include: (1) What are the initial or current site conditions? (2) Is performance satisfactory during construction and facility operations? and (3) Is performance satisfactory during special loading conditions such as rapid drawdown or upstream construction?
Step 3	Select the most important parameters to be monitored, magnitudes of change, and each type of instrumentation considering parameter variations resulting from both cause and effect. For example, lateral slope displacements may result from elevated groundwater levels, and specific hazard warning levels can be determined. If a clear purpose cannot be defined, the need for instrumentation cannot be defended.
Step 4	Identify staffing responsibilities for monitoring, interpreting and devising remedial action(s) in terms of required labor and materials needed to respond to problem situations, including resources and reporting requirements.
Step 5	Select instruments and locations considering reliability for measurement of the desired parameter within the project site setting and the appropriateness of the location for measuring predicted behavior, compatibility with methods of analysis to be used, and device survivability. Other features that should be considered include in-service calibration, operator skill requirements, potential interference during construction, and location access during installation and reading.
Step 6	Develop record of factors that may affect the measured data and establish procedures for controlling data quality such as geologic conditions in the vicinity of the instrument, use of redundant instruments, regular examination of data for consistency, and in-service calibration checks.
Step 7	Prepare instrumentation system report, budget and procurement specifications summarizing Steps 1 to 6 and including sections on the contracting method and basis for instrument procurement and field instrumentation services.
Step 8	Integrate instrumentation system report into the Operation and Maintenance Plan , including data collection, processing, presentation, interpretation, reporting, calibration and maintenance.

(ADAPTED FROM DUNNICLIFF, 1993)

is required for a relatively short period of time up to a few years, or for a much longer time period up to and including the expected service life of the refuse facility.

13.2.1 Movements and Displacements

The performance of embankments can generally be evaluated by monitoring the movement of the embankment surface or configuration changes within the embankment and its foundation. For static loading conditions (i.e., no earthquake or blasting loads), movement can be determined by: (1) visual observation, (2) measurement of surface movements, and (3) measurement of internal movements. [Table 13.3](#) provides an evaluation of each approach relative to complexity and cost, applicability, and limitations. Additional information is provided by Dunnycliff (1981), Hanna (1985), Bartholomew et al. (1987), Dunnycliff (1993) and USACE (1995c).

13.2.1.1 General Observations

Periodic surveying of monuments and instruments provides an effective means for observing the magnitude and rate of change of deformations at a coal refuse disposal facility during:

- Initial facility development and initial disposal operations
- Normal disposal operations

TABLE 13.2 PERFORMANCE QUESTIONS FOR SLURRY IMPOUNDMENTS

Questions	Typical Instruments for Monitoring	Other Typical Measures for Monitoring Suspect Conditions
Embankment Conditions		
1. Where is the phreatic surface: a. in the refuse embankment?	Piezometers	
b. in the fine refuse deposit (e.g., when upstream construction is employed)?	Closed-System Piezometers	
2. What is the seepage rate?	<i>Weirs</i>	
3. What is the discharge rate from an internal drain?	<i>Weirs</i>	
4. Are embankment grades and alignments conforming to plans?	Survey Monument	<i>Survey Methods</i>
5. Are unacceptable deformations occurring: a. at the embankment surface? b. within the embankment?	Survey Monument	<i>Survey Methods Inclinometer</i>
6. Could unacceptable pore-water pressure develop due to the effects of the rate of fill placement, rapid drawdown, or earthquake loading?	Closed-System Piezometers	
7. Could unacceptable deformations develop due to the effects of the rate of fill placement, mine subsidence, rapid drawdown, or earthquake loading?	Survey Monuments <i>Extensometers</i>	<i>Survey Methods Inclinometer</i>
Foundation Conditions		
1. Could unacceptable deformations develop due to the presence of compressible foundation materials, subsidence from mining below the embankment or impoundment, or earthquake loading?	Survey Monuments <i>Extensometers</i>	<i>Geophysical Surveys</i>
2. Could unacceptable pore-water pressures develop due to the effects of rapid embankment construction, upstream construction over soft fine refuse, or earthquake loading?	Closed-System Piezometers	
3. Could unacceptable pore-water pressures develop due to the effects of an elevated reservoir level or an undetected pervious stratum?	Closed-System Piezometers	
Abutment Conditions		
1. Will excavation or natural slopes be stable: a. during construction? b. long term?	Survey Monuments	<i>Survey Methods</i>

TABLE 13.2 PERFORMANCE QUESTIONS FOR SLURRY IMPOUNDMENTS
(Continued)

Questions	Typical Instruments for Monitoring	Other Typical Measures for Monitoring Suspect Conditions
2. Could unacceptable deformations or cracking develop due to subsidence from mining beneath the abutment or impoundment?	Survey Monuments <i>Extensometers</i>	
3. Could unacceptable pore-water pressures develop due to the effects of an elevated reservoir level or an undetected pervious stratum?	Open-Standpipe Piezometers	
Reservoir Level		
1. Is the water level in the impoundment at an acceptable level, and is there adequate freeboard?	Staff Gage	
Breakthrough Potential		
1. Could an unusual increase in seepage quantity or change in seepage quality from underground mine workings indicate a potential problem related to impoundment leakage or possible breakthrough?	Weir	
2. Could the level of water in underground mine workings have an effect on the impoundment or indicate possible breakthrough?	Observation Well	
Decant Works, Primary or Emergency Spillways		
1. Is the flow rate from the decant acceptable?	Weir	Pipe Discharge Measurement
2. Is the strain within the flexible decant conduit acceptable considering embankment loading and backfill support?	<i>Dial Gage</i> <i>Deflectometer</i> <i>Circumferential Survey</i>	<i>Camera</i>
3. Is there movement affecting the primary conduit spillway joints (or cracks) that could lead to separation?	<i>Dial Gage</i> <i>(Crack Monitor)</i>	
4. Is there movement affecting the lined emergency spillway joints (or cracks) that could lead to separation?	<i>Dial Gage</i> <i>(Crack Monitor)</i>	
5. Are the excavation slopes for the emergency spillway stable?	<i>Survey Methods</i> <i>Survey Monuments</i>	
Weather Conditions		
1. How do changes in measured facility performance (e.g., phreatic surface, flow from internal drains) relate to changes in weather conditions such as precipitation?	Precipitation Gage	Weather Station

Note: Instrumentation shown in italics is generally considered when adverse conditions are observed or suspected (e.g., seepage or movement).

- Changes in the rate of disposal, in the physical characteristics of the fine and coarse coal refuse components, or in the phreatic or piezometric levels in the embankment
- Facility abandonment

Excessive movement or progressively increasing rates of movement can provide a warning of a potential failure and may indicate that modification of a facility operation is necessary.

Long-term periodic monitoring of surface movements provides an inexpensive record of embankment behavior. If changes due to natural phenomena or operations result in a reduction in stability not anticipated in the design, long-term records can provide a forewarning of impending distress. The potential value of surveyed records in relation to their cost justifies the installation of benchmarks and monuments for most types of refuse facilities, even if the instrumentation must be regularly monitored during the facility life and to abandonment.

TABLE 13.3 SUMMARY OF GENERAL METHODS FOR DETECTING EMBANKMENT MOVEMENTS AND DISPLACEMENTS

Technique	Complexity and Cost	Applicability	Limitations
Visual Observations	Low to Moderate	Normally used for monitoring general conditions to identify areas of potential distress where more detailed evaluation is required.	Surface cracking indicates the occurrence of displacements, but does not provide quantitative data.
Measurements of Surface Movements	Low to High	Reasonable costs and high accuracy provide desirable monitoring procedure for practically any condition. Should be routine practice for all facilities.	Surface movements can be very local without being significant to overall safety of facility.
Measurement of Internal Movements	Moderate to High	Necessary when cause of movements is important and surface measurements are not sufficient for interpretation.	Programs requiring complex instrument installation, monitoring and interpretation must be performed by an expert.

If a surface movement monitoring program is implemented primarily to develop long-term records of embankment behavior, the measurement points are usually located along representative cross sections perpendicular to the longitudinal axis of the embankment (e.g., at the toe, on benches, and at the top of slope along each section) and at readily accessible points on other facility structures. A limitation of conventional surveying techniques is that only movements at the surface are monitored. Observations at the surface are not always sufficient for determining if the movements are shallow and relatively unimportant or if they are associated with deeper, more significant conditions occurring within the embankment or its foundation. In the latter case, it may be necessary to install more sophisticated subsurface instrumentation such as inclinometers to better define the mechanism causing the movement and its location.

Optical level surveys (land surveys) are often the best method for monitoring vertical movements due to:

- Settlement resulting from consolidation of an embankment foundation or constituent materials
- Impending stability failure due to embankment movement or foundation deformations
- Surface subsidence from underground mining

The order of accuracy required for land surveys depends on the total potential magnitude of movement, while the accuracy obtained is a function of the equipment and personnel employed and the reliability of benchmark datums used for control.

Monitoring of horizontal surface movements is useful for detecting conditions that may indicate impending instability or for verifying that such movements are not occurring. Preferably, identical reference points or monuments should be used for measuring both vertical and horizontal movements.

Instruments for measuring vertical displacements within an embankment or its foundation are useful when:

- Accurate settlement data are required for comparison to predicted embankment or foundation settlement.
- The integrity of an impervious core or internal drainage system is dependent on limiting the amount of settlement.
- Large settlements could affect drainage slopes and ditches after abandonment.
- A contractor is being paid for construction on a unit-price basis and the volume of material placed could significantly change based on the magnitude of settlement.
- A rigid structure is to be placed on an embankment at the completion of construction.
- The embankment was constructed over settled fine refuse or the embankment foundation is soft clay and potentially large settlements are a possibility.

The installation of internal settlement instrumentation is not generally recommended for routine refuse disposal embankment construction. However, several of the techniques discussed in the following section are relatively simple and inexpensive, and they may be considered when embankment settlement is important. The installation, monitoring and interpretation of data from these systems should only be undertaken under the supervision of a knowledgeable engineer.

Durability of the installed instrumentation is particularly important for systems placed in an embankment. Care in placement is critical, because instruments can often be irreparably damaged due to improper installation techniques. The high potential for corrosion at coal refuse facilities should always be considered, and plastic pipes are preferred over metal pipes unless it is known that high temperatures that might affect the long-term behavior of the plastic pipe could occur.

For all types of instrumentation, erroneous data are much more likely when vertical settlement is coupled with large horizontal movement. In such cases, instrumentation for measurement of both vertical and horizontal movements should be installed. The purpose of measurement of horizontal displacements within an embankment is normally to determine if there is instability and the depth at which movement is occurring or to verify that surface distortions due to creep movements do not have a deeper origin. Inclined meters are often used to determine the depth to the surface where movement is occurring prior to implementation of remedial measures so that the costly remedial effort is focused solely on the problem area.

Normally, sophisticated instrumentation is not required for newly-constructed refuse embankments designed in accordance with current engineering practice and constructed in conformance with detailed plans and specifications. Possible exceptions may include embankments:

- Located above populated areas.
- Constructed where site conditions do not permit access for the desired scope of exploration and testing, such as where steep slopes and/or dense ground cover limit access to drilling and sampling equipment.

- Supported on a material that cannot be readily tested, such as settled fine refuse or soft, sensitive clay.
- Constructed over or adjacent to areas of past or active underground mining.
- Where dynamic loading is a critical consideration during design.

More sophisticated instrumentation is often used to investigate existing facilities where limited data relative to site conditions and construction practices (e.g., fill material characteristics) are available. The value of installing and monitoring the instrumentation must be carefully judged against the ability to interpret the data (i.e., the ability to recognize adverse conditions and distress). When internal movement instrumentation is required, the location and arrangement of instruments should be based on the judgment of an expert, and the installation and monitoring should be conducted under the direct supervision of an engineer or technician that is experienced with the equipment used.

Movements associated with dynamic loads (e.g., earthquake or nearby blasting) differ from those associated with static loads in that measurements must be taken during the occurrence of the dynamic condition. Generally, where earthquake considerations are important in the site selection process, potential dynamic displacements are estimated based upon seismic engineering analyses and no on-site measurements are involved. However, in the case of blasting, the amount of movement realized is dependent upon geologic conditions, the explosive material and blasting technique, and the location of the blast relative to the embankment. Often, blasting effects are minor and will not affect embankment stability. Exceptions are when blasting is very close to an embankment or other facility structure or rock abutment or the magnitude of the blast is unusually high. In these isolated cases, surface monitoring of resultant movements may be justified for verification that no significant damage to the refuse disposal facility has occurred. Instrumentation for this purpose is discussed in [Section 13.2.4.2](#).

13.2.1.2 Movement Measurement Techniques

As listed in [Table 13.4](#), Dunnicliff (1993) identifies the following as general categories of deformation measuring techniques:

- Surveying methods
- Surface extensometers
- Tiltmeters
- Probe extensometers
- Fixed embankment extensometers
- Fixed borehole extensometers
- Inclinerometers

Descriptions of instrumentation associated with each of these deformation measurement techniques are presented in the following sections. Supplemental techniques for deformation measurement, including transverse-deformation gages, liquid-level gages, time-domain reflectometry, and fiber-optic gages are presented in [Appendix 13A](#) at the end of this chapter.

13.2.1.2.1 Surveying Methods

Surveying methods are generally used for monitoring the magnitude and rate of vertical and horizontal movement of the ground surface, structures, and accessible parts of subsurface instruments at construction sites (Dunnicliff, 1993). For many applications, these methods are adequate for performance monitoring, and instrumentation is used only if greater accuracy is needed or if subsurface movements need to be determined. When instrumentation is employed, surveying methods are often

TABLE 13.4 INSTRUMENT CATEGORIES FOR MEASURING MOVEMENTS

Category	H	V	A	R	S	U	Conditions for Use	Relative Complexity	Relative Cost	Applicability to Coal Refuse Disposal Facilities
Surveying Methods	•	•	•	•	•	•	Surface movements	Simple	Low to Moderate	Routine for all embankments.
Surface Extensometers										
• Crack gages	•	•	•	•	•	•	Deformation between fixed points	Simple	Low	Usually limited to structure and rock movements, including subsidence monitoring.
• Convergence gages										
Tiltmeters							Rotations on a surface	Simple	Low to Moderate	Usually limited to structure movements.
Probe Extensometers										
• Mechanical probe gages	•	•	•	•	•	•	Displacement (usually vertical) between two or more points along a single axis	Moderate to complex	Moderate	Useful if settlement of soft foundation is critical; normally single settlement plates are adequate.
• Electrical probe gages										
• Probe extensometers with inclinometers										
Fixed Embankment Extensometers							Settlement at single depth. Practical for pre- or post-construction installation	Simple	Low	Useful if settlement of soft foundation is critical.
• Settlement platform	•	•	•	•	•	•				
Fixed Borehole Extensometers							Displacement between two or more points along a single axis	Moderate to complex	Moderate	Useful if settlement of soft foundation or rock slopes is critical.
• Single- and multi-point	•	•	•	•	•	•				
• Subsurface settlement points and rod gages										
Inclinometers							Movement profiling in vertical, horizontal or inclined casings	Moderate	Moderate	Most commonly used method, but limited to zones where deformation profiles are needed or are a concern.
• In-place inclinometers	•	•	•	•	•	•				
Transverse-Deformation Gages							Movement profiling	Moderate to complex	Moderate to High	Useful only if automatic monitoring is planned.
• In-place inclinometers	•	•	•	•	•	•				
Liquid-Level Gages							Settlement of foundation or embankment fill	Moderate to complex	Moderate	Useful if settlement of soft foundation is critical.
• Single- and multi-point gages	•	•	•	•	•	•				
• Full-profile gages										
Time-Domain Reflectometry							Movement detection at locations along cable axis	Moderate	Low to Moderate	Still evolving method, but shows excellent promise.
• Time-Domain Reflectometry	•	•	•	•	•	•				
Fiber-Optic Sensors							Local deformation and strain measurements	Moderate	Moderate to High	Still evolving method, but shows excellent promise, especially for long-term monitoring applications.
• Fiber-Optic Sensors	•	•	•	•	•	•				

Legend: H = Horizontal deformation
V = Vertical deformation

A = Axial deformation
R = Rotational deformation

S = Surface deformation
U = Subsurface deformation

(ADAPTED FROM DUNNICLIFF, 1993)

used for locating the instruments relative to a reference datum. Table 13.5 summarizes the advantages, limitations, approximate accuracy, relative complexity, cost, and applicability to coal refuse disposal facilities of the various surveying methods identified by Dunnycliff (1993).

Optical Leveling

Most settlement surveys at construction sites are conducted using engineer's levels at second- or third-order accuracy. Second-order leveling surveys are generally confined to extending vertical control data over long distances. Second-order leveling involves limited sight distances (± 225 feet), balancing foresight and hindsight, careful plumbing of the level rod, and readings made on well-defined marks and stable turning points. Third order leveling surveys are used to establish vertical control and to maintain benchmarks for project control, construction survey control, topographic survey control and major structure points. Third-order leveling permits greater sight distances (± 300 feet), along with balancing foresight and hindsight, plumbing of the level rod, and readings made on well-defined marks and stable turning points. For the magnitude of elevation change typically of interest at coal refuse disposal facilities, a third-order survey is usually adequate.

An important requirement for measuring horizontal movements is the establishment of reference monuments away from the embankment being monitored that are known to be fixed against horizontal movement and are convenient for the method of measurement used. This requirement may be difficult in many coal mining areas where natural slopes are steep with resulting downhill creep of the surface soils and where surface strains from nearby mine subsidence may be present. Where possible, reference monuments should be placed on flat natural ground or on bedrock by excavating holes in the soil/rock and backfilling them with concrete. For monuments in soil, the depth should extend below the maximum depth of frost penetration. Where assurance of undisturbed location is not possible for the primary reference monuments used for routine monitoring, they should be closed into a larger survey traverse or triangulation network for occasional checking of their locations. The large traverse should preferably have at least two permanent monuments in an area minimally susceptible to movement, such as adjacent to a highway in a broad valley bottom that does not overlie coal seams. Additional discussion of monuments and benchmarks is provided at the end of this section.

Trigonometric Leveling

Trigonometric leveling uses electronic distance measuring (EDM) equipment to measure the slope distance from the survey instrument to a prism on the surveyed location and to calculate the elevation and horizontal position of the surveyed location. The angle between the horizontal and surveyed location can be measured using a semi-precise (6-arc-second) or a precise (1- or 2-arc-second) theodolite.

Distance Measurement by Taping

Distance measurement by taping is probably the easiest measurement technique for horizontal movements because it requires only the use of a steel tape. When a known fixed point can be located in the direction of anticipated movement, this procedure consists of measuring the distance between the fixed reference and the monuments of interest. Typical corrections for sag, temperature and slope should be applied in order to obtain accurate measurements. The limitations of tape measurement should not preclude its use, because it may be the only means for locating lost reference points covered by deep snow or inadvertently buried by refuse placement.

Electronic Distance Measurement

Except for distances less than about 200 feet, distance measurement by taping has been replaced by EDM equipment. EDMs are used to directly measure the distance change or lateral position change

by triangulation. EDMs make use of electromagnetic radiation (or lasers) to measure the distance between the instrument and a reflector prism.

Theodolite and Scale

Offsets from baseline using a theodolite and scale are measurements at a right angle to a baseline. These surveys are typically used for grade control for embankments and roadways. Laser beam leveling and offsets provide a faster and more accurate alternative to optical leveling.

Total Station Survey

Total station instruments combine electronic distance measurement, digital theodolites and microprocessors to simultaneously measure slope length and angle, calculate horizontal and vertical distance, and display the results in real time. Typically, a reflector prism is manually positioned at locations of interest, and the data are recorded and processed by the total station. This technology can provide real-time monitoring of predetermined points through use of one or more automated total stations combined with multiple-prism targets, a data acquisition system, and software interfaces. For this application, prism targets are mounted on the surface of the features to be monitored and are programmed into the routine of the total station. The survey frequency can vary (typically every two to five minutes) depending on the number of targets programmed into the total station's routine. Each automated total station can monitor up to about 100 prism targets.

Traverse Lines and Triangulation

Traverse lines and triangulation are conventional survey techniques that have been used for decades. Their improved accuracy in recent years is due to the use of more precise equipment used to measure distance (EDMs) and angles (theodolites) between reference control points. A traverse is used to determine change in lateral position through measurement of successive distances and angles. If a traverse returns to its starting point, the sum of the interior angles of the enclosed polygon can be calculated and adjusted for measurement errors. Triangulation can also be used to determine change in lateral position. This is accomplished by accurately measuring a baseline offset from the surveyed locations and the angles between the ends of baseline and the surveyed locations, as illustrated in [Figure 13.1](#). Then by periodic re-sighting on the surveyed locations from the ends of the baseline, changes in lateral position can be calculated, assuming the baseline is located on stable ground.

Airborne Mapping Systems

Airborne methods include photogrammetric and LIDAR mapping systems. Photogrammetry is a remote-sensing technology in which geometric properties of objects are determined from photographic images. Photogrammetric methods can be used to record movement of hundreds of survey points at one time and thus provide an overall pattern of deformation, but the accuracy is affected by weather conditions, baseline measurements and interpreter skill.

Light Detection and Ranging (LIDAR) is a remote sensing system used to collect topographic data and develop topographic maps. LIDAR consists of a laser imaging device, an inertial navigation system, a GPS receiver and a computer. The technology can be used to map and determine coordinates of dense patterns of ground points, which can be used to develop an image of the ground surface. The data can be used to produce digital elevation models (DEMs) and subsequently topographic maps. When LIDAR is used, weather conditions must be monitored because the flights cannot be flown during times of rain or fog, as the water vapor in the air could cause the laser beams to scatter and give false readings.

Global Positioning System (GPS)

The GPS consists of a constellation of 24 satellites. Each satellite orbits the Earth twice a day at an altitude of about 12,500 miles and continuously transmits information on specific radio frequencies

TABLE 13.5 SURVEYING METHODS

Method	Advantages	Limitations	Approximate Accuracy	Relative Complexity	Cost	Applicability to Coal Refuse Disposal Facilities
Elevations by optical leveling	Fast, particularly with self-leveling equipment Uses widely available equipment	First order leveling requires high-grade equipment and careful adherence to standard procedures	<u>Third order:</u> $\pm 0.05 \text{ ft} \times \sqrt{\text{miles}}$ <u>Second order:</u> $\pm 0.025 \text{ to } 0.033 \times \sqrt{\text{miles}}$ <u>First order:</u> $\pm 0.012 \text{ to } 0.020 \times \sqrt{\text{miles}}$	Simple	Low to Moderate	Routine for all embankments
Trigonometric leveling	Long range; fast and convenient; can be done simultaneously with traversing	Accuracy is influenced by atmospheric conditions; requires a very accurate measurement of zenith angle	<u>Third order:</u> $\pm 0.05 \text{ ft} \times \sqrt{\text{miles}}$ <u>Second order:</u> $\pm 0.025 \text{ to } 0.033 \times \sqrt{\text{miles}}$	Simple for 3rd Order; Moderate for 2nd Order	Low for 3rd Order; Moderate for 2nd Order	Routine for all embankments
Distance measuring by taping	Direct measurements	Requires clear, relatively flat surface between measuring points and reference datum; movement can only be measured in one direction; monuments must be located along a straight line with ready access between points; tape should be checked frequently against standard; except for short measurements, taping has been replaced by EDM.	<u>Third order:</u> $\pm 0.0033 \text{ to } 0.0016$ of distance between instrument and surveyed location <u>Second order:</u> $\pm 0.00005 - 0.00002$ of distance <u>First order:</u> ± 0.000003 of distance	Simple	Low to Moderate	Routine for all embankments
Electronic distance measurement (EDM)	Long range; fast and convenient; very accurate.	Accuracy is influenced by atmospheric conditions	For distance: $\pm 0.001 \text{ to } 0.03 \text{ ft}$ For lateral position change by triangulation: $\pm 0.005 \text{ to } 0.03 \text{ ft}$	Simple to Moderate	Low to Moderate	Routine for all embankments
Offsets from baseline using theodolite and scale	Direct measurements	Requires baseline unaffected by movement	$\pm 0.001 \text{ to } 0.005 \text{ ft}$	Simple	Low to Moderate	Routine for all embankments

TABLE 13.5 SURVEYING METHODS
(Continued)

Method	Advantages	Limitations	Approximate Accuracy	Relative Complexity	Cost	Applicability to Coal Refuse Disposal Facilities
Laser beam leveling and offsets	Faster than conventional optical methods; readings can be made by one person	Seriously affected by air turbulence, humidity, and temperature differential; requires curvature and refraction corrections beyond about 200 ft	± 0.01 to 0.03 ft	Simple	Low	Routine for significant embankments
Traverse lines	Useable where direct measurements are not possible	Accuracy decreases as number of legs in traverse increases; traverse should be closed if possible	± 0.00003 to 0.000007 of distance between instrument and surveyed location	Simple	Low to Moderate	Routine for significant embankments
Triangulation	Useable where direct measurements are not possible; baseline can be located to avoid active construction areas	Requires accurate measurement of angles and baseline length	± 0.00003 to 0.000001 of distance between instrument and surveyed location	Moderate	Low to Moderate	Routine for significant embankments
Photogrammetric methods	Can record movement of hundreds of potential points at one time for determination of overall deformation pattern	Weather conditions can limit use; interpretation requires specialist; for good accuracy the baseline should not be less than one-fifth of the sight distance	± 0.0002 to 0.00001 ft	Complex	Expensive	Non-routine for significant embankments
Global positioning system (GPS)	Operates with little attention from personnel; can be set to trigger a warning device; very accurate; does not require line of sight; measurements can be made in almost any weather condition	Requires open sky line of sight	Static and Relative Positioning: $\pm (0.016 \text{ ft} + 1 \text{ ppm})$ Requires 10 to 30 minutes observation per point depending on method of survey and whether single or dual frequency receiver is used.	Complex	Moderate to Expensive	Non-routine for significant embankments

Note: $\sqrt{\text{miles}}$ = square root of distance in miles

(ADAPTED FROM DUNNICLIFF, 1993)

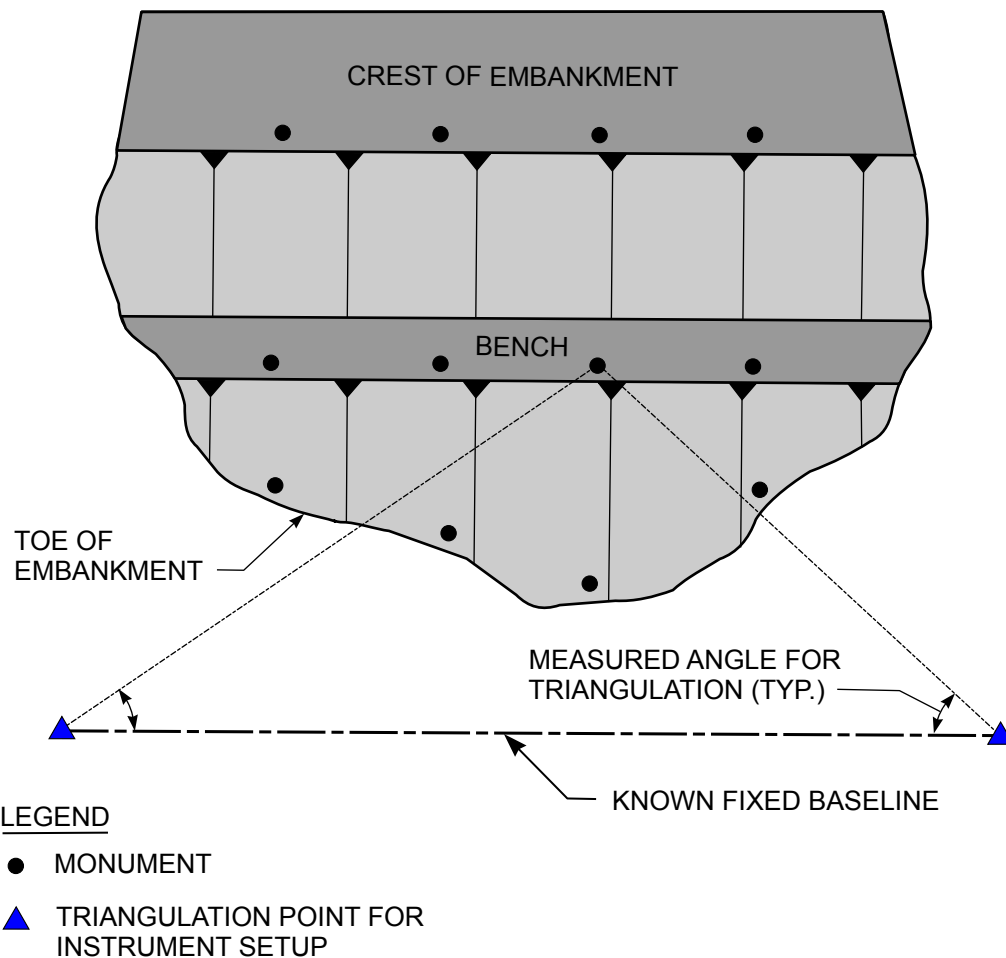
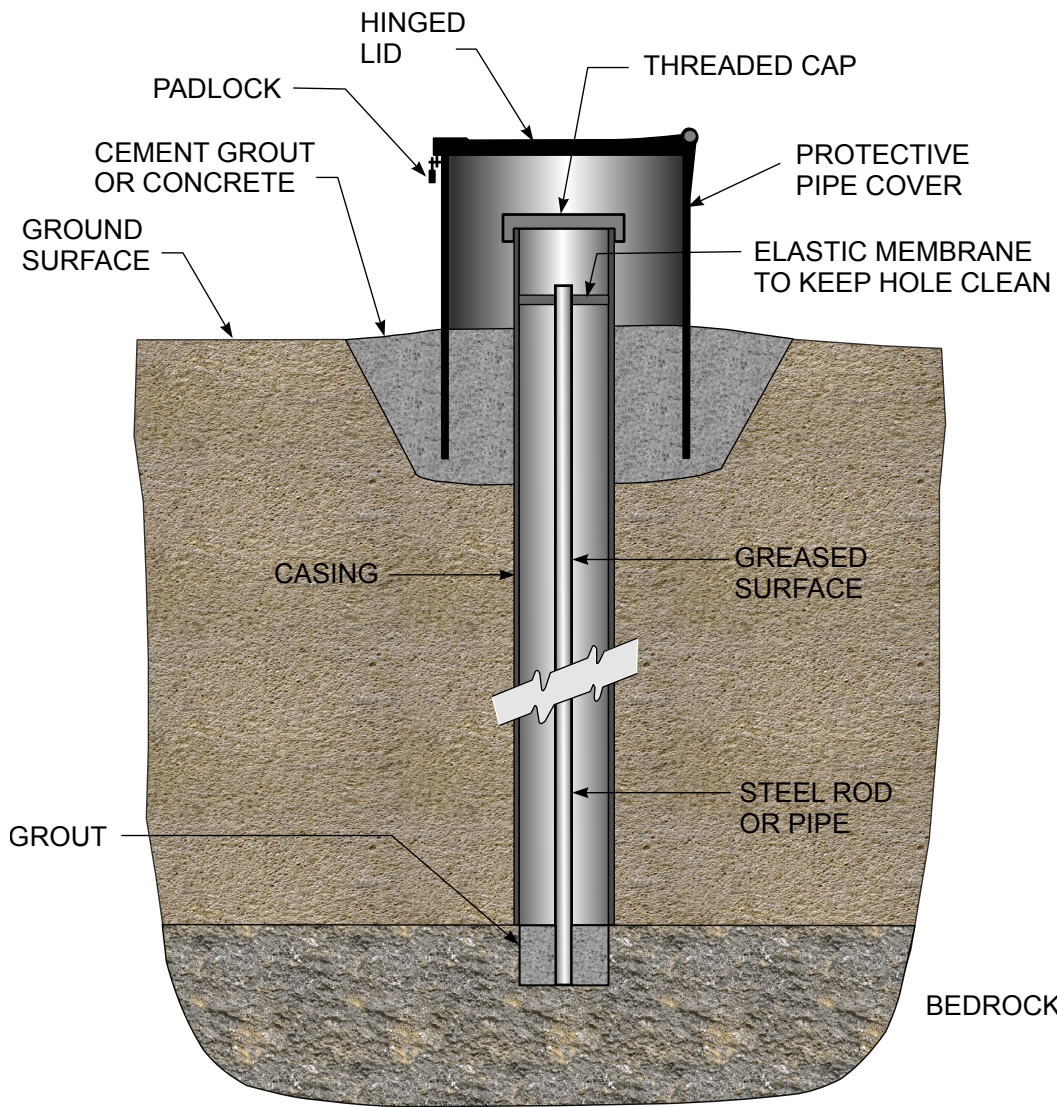

FIGURE 13.1 LOCATION OF MONUMENTS USING TRIANGULATION

to ground-based receivers. Using sophisticated receivers and data-analysis techniques, receiver positions can be determined. The GPS satellites continuously transmit an estimate of their position, digital codes, and a precise time signal. A GPS receiver uses an internal clock and the codes to determine the distances to at least 4 satellites. Distance is calculated by multiplying the time it takes the radio signals to reach the receiver times the speed of light. Knowing where the satellites are located when signals are transmitted, the receiver calculates its position. GPS equipment is becoming more reliable, cheaper, faster, and easier to use compared to conventional instruments. New hardware, field procedures and software have also been developed to assist users in data collection and processing. GPS equipment is now used for a wide range of monitoring applications.

A stable reference datum is required for all survey measurements pertaining to deformation. A benchmark is a reference datum for vertical movements and a horizontal control station or reference monument is a reference datum for horizontal movements. As a minimum, the datum benchmark should be placed in the ground, on a structure or on a rock outcrop in such a manner that the effects of weather (frost heave) or equipment travel will not alter its position. It should also be located well away from the embankment area so that increased earth loads or water pressures in the embankment do not significantly change the ground elevation at the benchmark. Where rock is shallow, an excavated hole to rock with concrete backfill and an embedded brass pin reference point is normally acceptable. When rock is deep, the most reliable benchmark consists of a steel rod installed inside a casing placed through overburden into bedrock. The rod should be isolated from the casing by nylon spacers, and the casing should be provided with a protective cover, as shown in [Figure 13.2](#). Because the outer casing may be disturbed or compressed due to settlement of the surrounding material, the



13.2a TYPICAL ARRANGEMENT

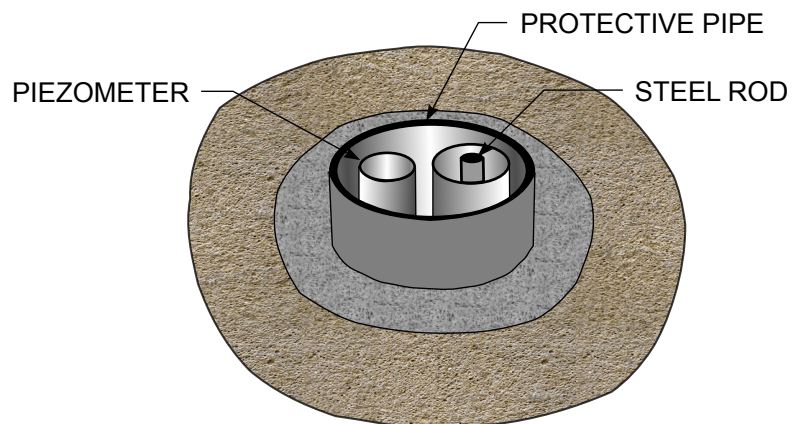

13.2b ROCK BENCHMARK IN COMMON

FIGURE 13.2 EXAMPLE OF BENCHMARK IN ROCK

benchmark should be placed on the top of the inner rod, which is isolated from the movement of the casing. The protective cover will prevent damage due to material becoming wedged between the inner rod and the casing or due to vandalism.

In areas with nearby mining activity, associated movements of the ground surface may occur on adjacent hillsides (both surface heave and subsidence have been observed to occur for horizontal distances of more than several hundred feet from the nearest point of mining), so it may be necessary to construct a benchmark in a deep hole so that mining in the coal seam does not affect the benchmark. If the depth of mining is such that the cost of constructing a deep benchmark is prohibitive, a project benchmark should be established and should be periodically checked against other benchmarks in the region. In all cases, a minimum of three datum benchmarks should be established for periodic checking. These benchmarks should be located on opposite sides of the facility and in locations where they will not be affected by weather or subsidence conditions.

Reference points or monuments where surface settlement monitoring is desired can range from stakes or rods driven into the ground to carefully installed concrete cylinders. Examples are shown in [Figure 13.3](#). In all cases, the point of measurement must be clearly identified so that the same location is used each time. Brass or steel rods or pipes set in concrete or rock or chiseled/painted crosses are suitable.

Except for rapidly established and very short-duration monitoring programs, driven rods should be avoided because this type of arrangement can be easily disturbed. If used, the minimum depth of embedment should be at least two feet, and the maximum extension above grade should be one foot or less to minimize tilting or bending of the rod. Also, because settlement points are often located in areas of high equipment activity, they should be well marked with stakes and flags to minimize loss and disturbance. Where loss of a monument would reduce the extent or accuracy of an important survey, up to twice the number believed necessary may be installed. The monument shown on [Figure 13.3c](#) can be used where surface creep is significant and conditions at depth (e.g., below the frost line or in rock or stable strata below the ground surface) better represent slope performance.

13.2.1.2.2 Surface Extensometers

Surface extensometers are devices used to monitor changes in distance between two points at the ground surface or on a structure (Dunnicliff, 1993). Surface extensometers are usually referred to as crack gages or convergence gages. Crack gages are used to monitor tension cracks behind slopes, across a joint or fault in a rock mass, or in concrete structures. Convergence gages have been used to measure the displacement between two surface monuments as part of the monitoring of ground surface strain induced by longwall mining near an impoundment. Mechanical crack gages include pins and tape, pins and steel ruler or caliper, pins and mechanical extensometer, and grid crack monitors. For each of these devices, the pins or grid crack elements are anchored on opposite sides of the discontinuity, and the distance between the anchored elements is measured periodically to determine the change in separation. Each of these types of surface extensometer is inexpensive and has a precision ranging from ± 0.01 to ± 0.1 inches. The principal limitation of mechanical crack gages is the relatively short span length between the pins. Additional details related to surface extensometers are provided in Dunnicliff (1993).

13.2.1.2.3 Tiltmeters

Tiltmeters are used for monitoring changes in inclination or rotation at the ground surface or on a structure in either a horizontal or vertical plane (Dunnicliff, 1993). A tiltmeter consists of a gravity-sensing device that is sealed in a housing. Some tiltmeters are fixed in place, and others are portable and can be used to monitor multiple locations by mounting on a fixture that is permanently attached to the monitoring location. The most common types of tiltmeters have an accelerometer transducer,

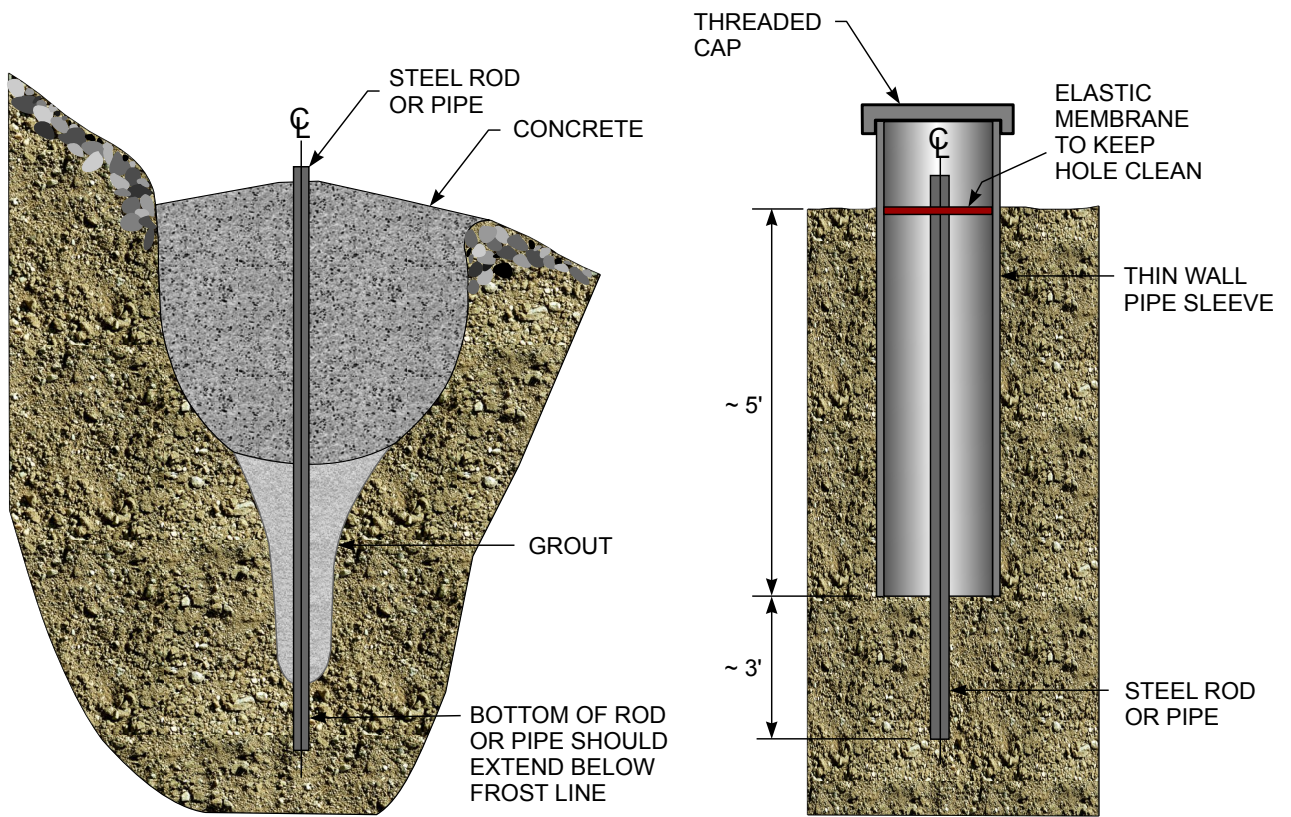

13.3a

13.3b

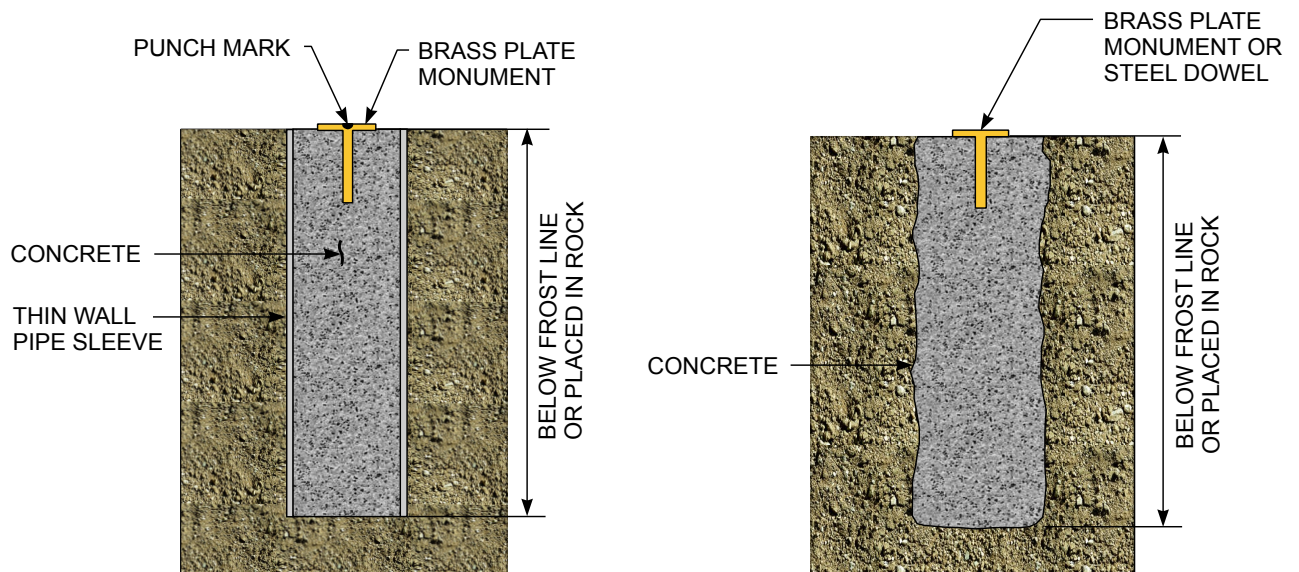

13.3c

13.3d

FIGURE 13.3 TYPICAL MONUMENT INSTALLATIONS

but devices with mechanical, vibrating wire and electrolytic transducers are also available. The typical range of accelerometer-type tiltmeters is $\pm 30^\circ$ from horizontal or vertical; the precision is typically ± 50 arc-seconds; and the temperature sensitivity is typically in the range of 2 to 3 arc-seconds/ $^\circ\text{F}$ (Dunnicliff, 1993).

13.2.1.2.4 Probe Extensometers

Probe extensometers are used to monitor changes in distance between two or more locations along a common axis by passing a probe through a pipe (Dunnicliff, 1993). As the probe passes through the pipe, it mechanically or electrically detects the measuring locations, and the distance between them is determined by physical measurement of the probe positions. If an exact measurement of probe location is required, one measuring point must be accessible so that its location relative to a reference datum can be determined by surveying methods. Depending on project requirements, the pipe may be vertical for measurement of settlement or heave, horizontal for measurement of lateral displacement, or inclined. Dunnicliff (1993) provides a complete summary of probe extensometer types, their advantages, limitations and approximate accuracy.

The most commonly used probe extensometers are:

- Gage with current-displacement induction coil
- Magnetic reed switch gage
- Combined probe extensometers and inclinometer casing

Induction-coil transducers are described in [Appendix 13A.2.4.6](#). When used as a probe extensometer, the device consists of a series of steel rings attached to and surrounding a telescoping or corrugated plastic pipe and a reading device consisting of a primary coil housed in a probe that is attached to a signal cable and current indicator. The pipe is installed in a borehole and backfilled. When the probe is inserted into the pipe, the steel rings can be located because the current indicator displays a maximum value at each ring location. The measurements enable determination of the distance between each ring, and a series of measurements over time permit determination of rate of deformation between the rings. Information related to installation, measurement precision and typical applications is provided in Dunnicliff (1993).

The magnetic reed switch gage is described in [Appendix 13A.2.4.5](#). When used as a probe extensometer, the device consists of a series of circular magnetic anchors surrounding a rigid or telescoping plastic pipe. The pipe is installed in a borehole and backfilled. When the probe is inserted into the pipe, the magnetic anchors are located and their position measured as the coupled oscillator in the probe is activated at each ring location.

The Sondex system consists of a probe, a signal cable, a cable reel with a built-in voltmeter, and a number of stainless steel sensing rings. A survey tape is typically connected to the probe. The sensing rings are fixed to a continuous length of corrugated plastic pipe that is installed coaxially with inclinometer casing or access pipe. The annulus between the corrugated pipe and the borehole wall is grouted. The corrugated pipe and its sensing rings settle with the surrounding ground. To obtain measurements, the operator draws the probe through the access pipe. A buzzer sounds when the probe is near a ring, and the voltmeter indicates peaks when the probe is aligned with a ring. The operator refers to the survey tape and records the depth of the ring. A sensitivity adjustment allows operation adjacent to steel pipes, piles, or other metal objects. Settlement and heave can be calculated by comparing the depth of each ring to its initial depth.

Several types of probe extensometers can be used in conjunction with inclinometer casing in a vertical borehole to permit measurement of both horizontal and vertical deformations in one installation. Incred

and Sondex are examples of this type of probe extensometer. The Increx system consists of a number of brass rings that are positioned at one-meter intervals along an inclinometer casing. The probe is positioned to successively take readings between each pair of rings. Periodic surveys are compared to the initial survey to determine changes in the distance between rings. If the distance has increased, extension has occurred; if the distance has decreased, compression has occurred. Movements can be referenced to the deepest ring, if it is located in stable ground, or the top of the casing can be optically surveyed. The systems can measure changes as small as 0.001 mm with an accuracy of ± 0.01 mm/m. A schematic illustration of a probe extensometer is provided in [Figure 13.4](#).

13.2.1.2.5 Fixed Embankment Extensometers

Fixed embankment extensometers are devices placed in an embankment fill during construction to monitor changes in distance between two or more points along a common axis without a movable probe. They are used to measure settlement, horizontal deformation or strain (Dunnicliff, 1993). The most common type of fixed embankment extensometer is a settlement platform. A settlement platform consists of a square plate or anchorage to which a riser is attached. If the fill height exceeds about 25 feet, the riser should be isolated from the surrounding fill by an outer pipe within which the riser can move freely. As the height of fill increases, the riser and outer pipe are raised by adding additional pipe lengths. Movements of the settlement platform can be monitored by optical survey of elevation of the top of the riser. A schematic illustration of a settlement platform is provided in [Figure 13.5](#). Settlement platforms are easy to construct, but they are easily damaged during construction as fill is placed and compacted near them. This problem can be avoided by using liquid-level gages, as described in [Appendix 13A.3.2](#).

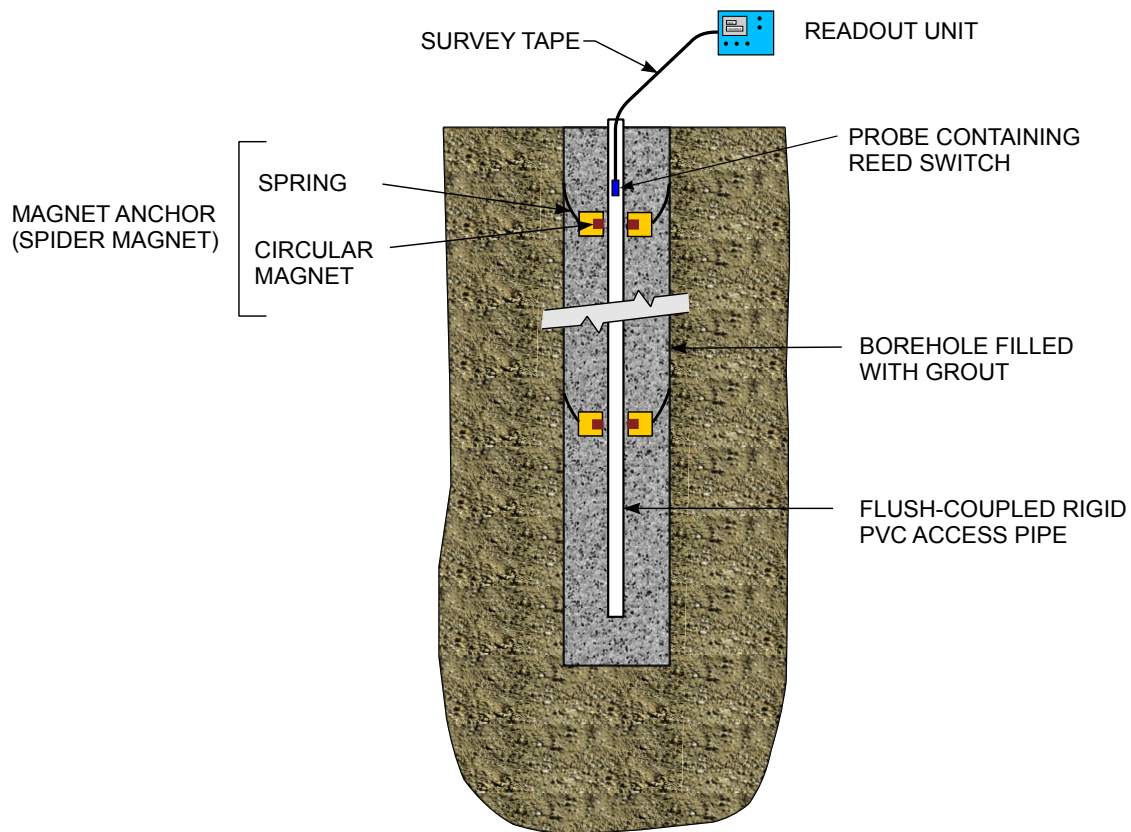

(DUNNICLIFF, 1993)

FIGURE 13.4 PROBE EXTENSOMETER

SETTLEMENT OF PLATFORM
IS DETERMINED BY MEASURING
ELEVATION OF THE TOP OF THE
RISER PIPE, USING SURVEYING
METHODS

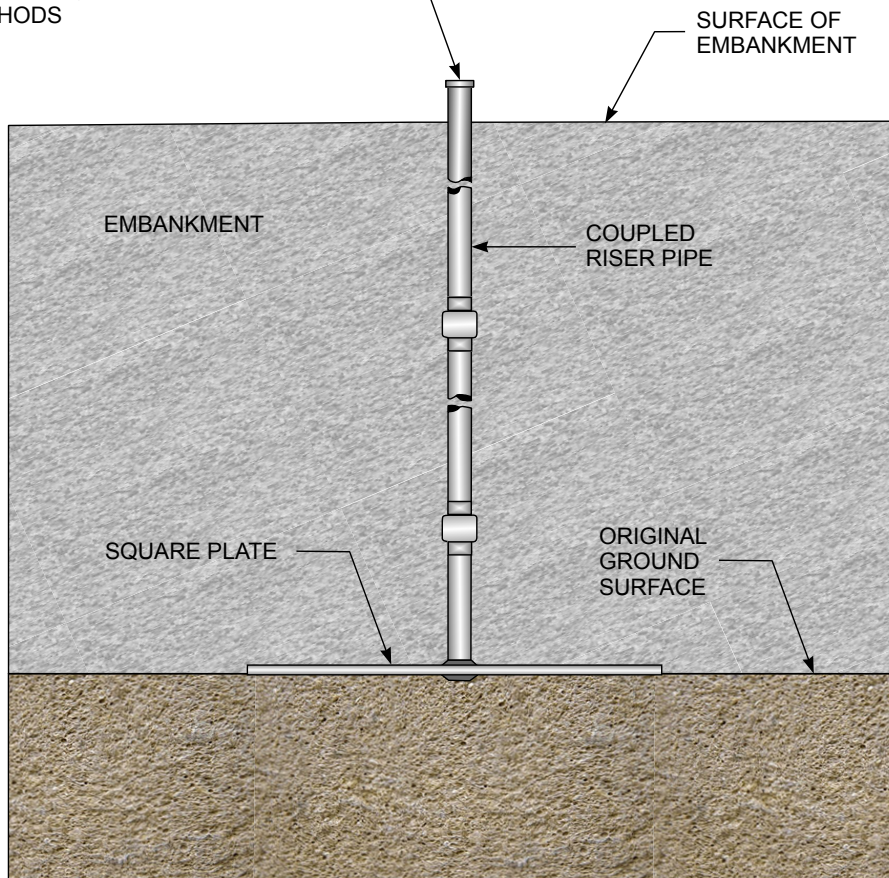

(DUNNICLIFF, 1993)

FIGURE 13.5 SETTLEMENT PLATFORM

Tensioned-wire gages and fixed embankment extensometers with Linear Variable Differential Transformers (LVDTs) have been used to monitor horizontal displacements in an embankment fill (Dunncliff, 1993). These devices have been largely replaced by probe or in-place inclinometers (Section 13.2.1.2.7) installed in a vertical borehole.

13.2.1.2.6 Fixed Borehole Extensometers

Fixed borehole extensometers are devices without moveable probes installed in boreholes in soil or rock and used to monitor the change in distance between two or more points along the borehole axis (Dunncliff, 1993). If measurement of the exact deformation at a specific location is required, one end of the extensometer must be fixed in stable ground or it must be accessible for optical survey. Fixed borehole extensometers can be used to monitor deformations behind rock slopes, foundation settlements, the progression of subsidence above underground mines, and heave at the base of open-cut excavations. A schematic illustration of a fixed borehole extensometer is provided in Figure 13.6.

The distance between the end of the rod and the face of the collar anchor can be measured using either a mechanical device (e.g., dial gage) or electrical transducer (e.g., LVDT). The device illustrated in Figure 13.6 is a single-point borehole extensometer (SPBX). A multiple-point borehole extensometer (MPBX) consists of several downhole anchors within a single borehole along with a rod and measur-

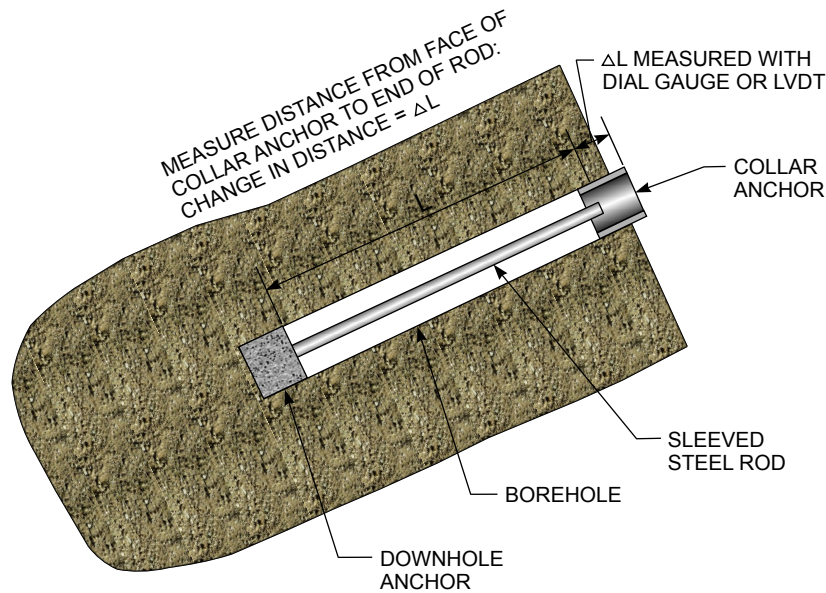

(DUNNICLIFF, 1993)

FIGURE 13.6 FIXED BOREHOLE EXTENSOMETER

ing device for each. MPBXs allow the measurement of deformation or strain patterns over the length of the borehole so that potential failure or large deformation zones can be identified. Fixed borehole extensometers can be manufactured to meet site-specific requirements. The principal feature differences include choice of rod or tensioned wire attached to the downhole anchor, downhole anchor type (i.e., mechanical, hydraulic or groutable), SPBX or MPBX, transducer type and extensometer head. Dunncliff (1993) provides guidance for selecting among these options for particular applications. The accuracy of the device depends on the type of mechanical or electrical transducer used to measure change in the anchor location.

13.2.1.2.7 Inclinometers

Inclinometers are devices used for monitoring displacements normal to the axis of a pipe by passing a probe along the pipe (Dunncliff, 1993). They can be used to determine the depth and profile of lateral displacement above and below a slide plane such as in a distressed slope. A gravity-sensing transducer in the probe measures inclination with respect to vertical. Normally the probe is inserted into a vertical or inclined borehole to measure lateral displacements in landslide zones or structures, but probes are available for use in horizontal pipe for obtaining profiles beneath embankments and structures.

Inclinometer systems have four primary components:

- A probe casing with tracking grooves that is permanently installed in a borehole (vertical or inclined application) or trench (horizontal application)
- A probe with a pair of wheel carriages housed in steel to confine the gravity-sensing transducer
- A portable readout for power supply and measurement of probe inclination
- A graduated electrical cable connecting the probe and readout unit

Figure 13.7 shows a schematic representation of the operation of an inclinometer for vertical and near-vertical applications. The inclinometer casing is installed and grouted along its full length into a borehole so that one pair of the four orthogonal grooves in the casing is normal to the displace-

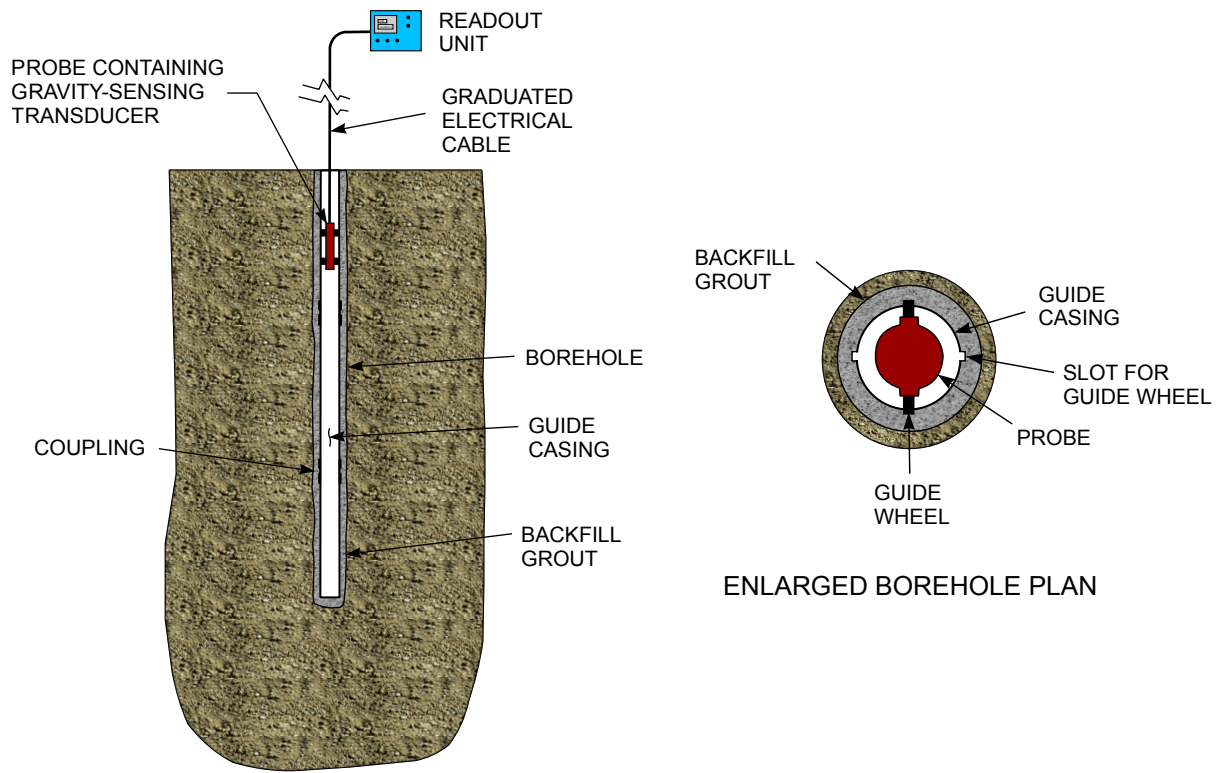

13.7a INSTRUMENT AND CASING ARRANGEMENT

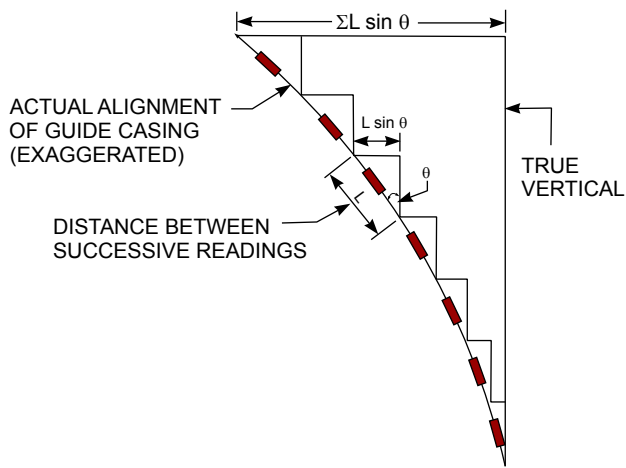

13.7b DISPLACEMENT COMPUTATION

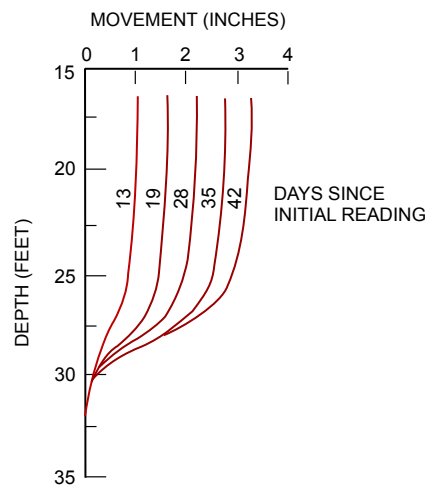

13.7c LOCATION OF PLANE OF MOVEMENT

(DUNNICLIFF, 1993)

FIGURE 13.7 INCLINOMETER OPERATION

ments being measured. Normally the casing is installed to a depth that provides fixity. Measurements are made by lowering the probe along the pair of grooves normal to the desired direction of movement observation to the bottom of the casing and then incrementally raising the probe and measuring probe inclination at each interval. Once the uppermost reading is made, the probe is removed from the casing, rotated 180 degrees to reverse the orientation of the probe in the casing, lowered to the bottom of the casing, and the measurement process is repeated at the previous depth intervals. Reversal of the inclinometer is performed in order to eliminate or minimize the effects of errors due to long-term drift of the gravity-sensing transducers. If a fixed base is not achieved, the top of the inclinometer casing must be surveyed each time measurements are taken so that measurements from one time interval can be compared to another. Dunnycliff (1993) provides additional details on inclinometer type; operation and calibration; casing types and installation; and data collection, processing and interpretation. The reported precision for inclinometers is: ± 0.05 to 0.5 inches per 100 feet for force-balance accelerometer transducers, ± 0.02 to 1 inch per 100 feet for bonded resistance strain gage transducers, and ± 0.1 to 0.5 inches per 100 feet for vibrating wire transducers (Dunnycliff, 1993).

13.2.2 Piezometric Levels and Pore-Water Pressures

Knowledge of the piezometric levels and pore-water pressures in foundations and embankment cross sections is important for safe operation of coal refuse disposal facilities. Elevated piezometric and pore-water pressure levels can be a pre-failure indicator of general and localized instabilities in foundation soils, downstream embankment slopes, upstream embankment slopes (due to failure of fine refuse following pushouts or upstream construction), and temporary excavations in soil or rock. Commonly used techniques for measuring piezometric levels and pore-water pressures are discussed in this section and are summarized in [Table 13.6](#). Valuable additional information related to groundwater monitoring instrumentation is provided by Dunnycliff (1981), Hanna (1985), Bartholomew et al. (1987), Dunnycliff (1993) and USACE (1995c).

Pore-water pressure and its significance relative to embankment fill and coal refuse behavior are discussed in [Section 6.5.7](#). Monitoring of pore-water pressures may be important for controlling construction and maintaining embankment or foundation stability. Devices for measuring pore-water pressure (piezometers) operate by admitting water through openings or a porous element, while restricting inflow of fine particles, such that the pore-water pressure can be determined from the elevation of water in the piezometer or by a pressure gage.

13.2.2.1 Piezometer Types

Piezometers generally fall into two categories: open system (e.g., observation wells and open standpipes) and closed system (e.g., pneumatic, vibrating-wire, and electrical-resistance). Both types have application at coal refuse disposal facilities.

Open observation wells are not selectively screened and thus provide limited information. For open standpipe piezometers, a screen or filter is placed in the zone of interest and sealed off so that only the sensing zone will be monitored. Water rises in the open piezometer to an elevation corresponding to the piezometric head in the zone being monitored. Measurement of piezometric head is typically accomplished using an electrical water level meter.

Closed-system installations such as vibrating-wire, pneumatic or electrical piezometers respond more quickly to changes in pore pressure because no significant flow of water is necessary. Also, these types of piezometers can be monitored remotely. While these devices have some reliability problems over long time periods, they can perform acceptably if they are properly selected for the applications required and environmental conditions encountered. Rapid response time is necessary when an embankment is constructed over a saturated and sensitive foundation material that could fail if excess pore pressures develop during construction and temporarily exceed those assumed in design. [Table 13.6](#) summarizes

TABLE 13.6 INSTRUMENTS FOR MEASURING GROUNDWATER PRESSURE

Instrument Type	Advantages	Limitations
Observation well	Can be installed by drillers without full-time participation of geotechnical engineering personnel	Provides undesirable vertical connection between strata so results can be misleading; should rarely be used
Open-standpipe piezometer	Reliable; long successful performance record; self de-airing if inside diameter of standpipe is adequate; seal integrity can be checked after installation; can be converted to diaphragm piezometer; can be used for ground-water sampling and permeability measurements	Long lag time; subject to damage during construction; extension of standpipe through embankment fill interrupts construction and leads to poor compaction; porous filter can plug due to repeated in- and out-flow; push-in versions subject to several potential errors
Pneumatic piezometer	Short lag time; calibrated part of system is accessible; minimum interference to construction; level of lead wires and readout independent of tip level; no freezing problems	Attention must be paid to many details during instrument selection; push-in versions subject to several potential errors
Vibrating-wire piezometer	Easy to read; short lag time; minimum interference to construction; level of lead wires and readout independent of tip level; lead wire effects minimal; can be used to read negative pore pressures; no freezing problems	Special manufacturing required to minimize zero shift; need for lightning protection should be evaluated; push-in versions subject to several potential errors
Electrical-resistance piezometer	Easy to read; short lag time; minimum interference to construction; level of lead wires and readout independent of tip level; suitable for dynamic measurements; can be used to read negative pore pressures; no problems with freezing in cold weather	Low electrical output; lead wire effects; errors caused by moisture, temperature and electrical connections are possible; long-term stability is uncertain; need for lightning protection should be evaluated; push-in versions subject to several potential errors

(ADAPTED FROM DUNNICLIFF, 1993)

the advantages and limitations associated with various types of piezometers, and [Figure 13.8](#) presents guidance regarding the approximate response times for various types of open- and closed-system piezometers as a function of the hydraulic conductivity of the soil surrounding the sensing zone. As shown in the figure, the response time to achieve 90 percent equilibration increases with decreasing hydraulic conductivity and with increasing volume of the sensing zone. Methods for estimating the response time are presented in Terzaghi and Peck (1967).

13.2.2.2 Observation Wells

Observation wells are not selectively screened in a specific formation. Thus, they will usually not provide useful information unless they are located in a single aquifer near the surface. While observing the water level in an open or cased borehole with an electrical water level meter, measuring tape and weight, or similar device is relatively easy, the measured water level may represent the contribution of many soil layers. Therefore, it is generally not possible to distinguish between pressures occurring at different elevations. Observation wells should only be used when relatively homogeneous embankment/foundation materials are present, and generally open-standpipe piezometers are preferred.

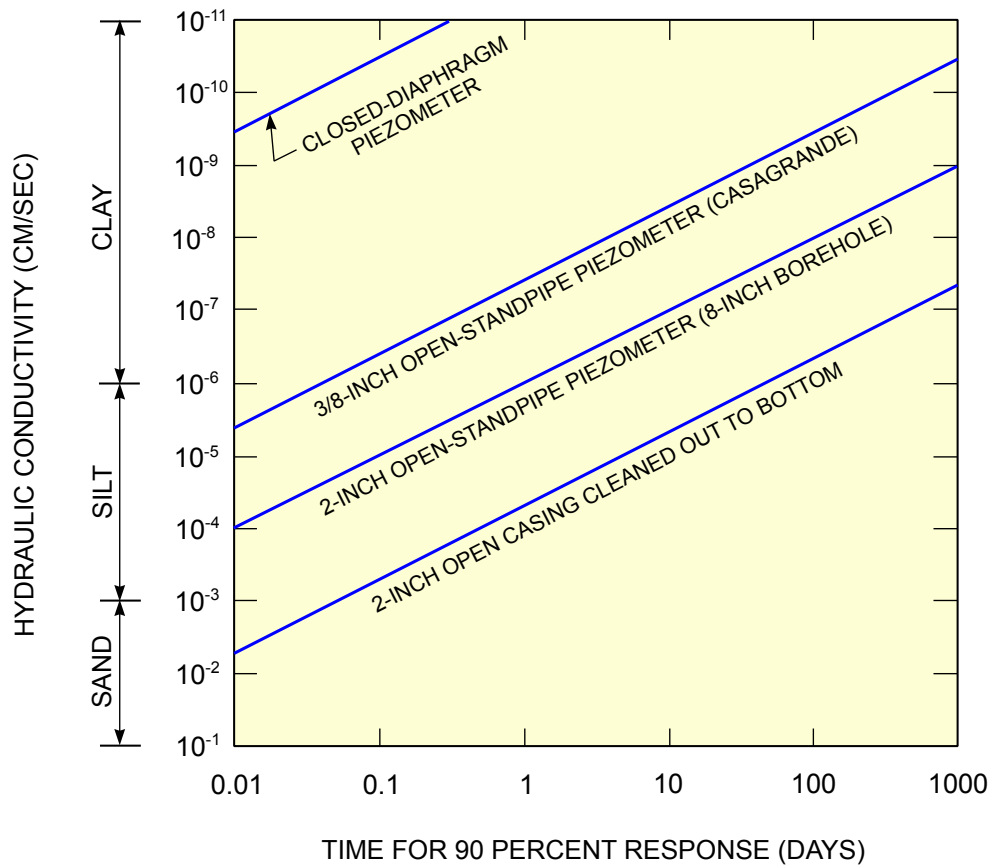

(ADAPTED FROM TERZAGHI AND PECK, 1967)

FIGURE 13.8 APPROXIMATE RESPONSE TIME FOR VARIOUS TYPES OF PIEZOMETERS

13.2.2.3 Open-Standpipe Piezometers

The disadvantages of observation wells can be overcome using open-standpipe piezometers with sensing elements that are sealed in the zones where pore-water pressures are needed. Open-standpipe piezometers are suitable for a wide range of hydraulic conductivities and may even be acceptable in low hydraulic conductivity conditions where there is little concern for rapid changes in excess pore pressure. It is the most common type of piezometer used in coarse refuse embankment stages.

This type of piezometer is normally installed in a borehole supported by temporary casing or a string of hollow-stem augers. The casing or internal diameter of hollow-stem augers should be of a size to permit placement of the backfill around the piezometer pipe, usually at least twice the diameter of the piezometer. When the desired depth is reached, small-diameter plastic pipe with slotted-pipe or other type of screen at the appropriate interval is inserted into the temporary casing or augers, and the casing or augers are extracted while the plastic pipe is held in place. Traditionally, as the casing or augers are extracted, the annulus between the pipe and borehole walls is backfilled with granular material around the sensing zone, a bentonite seal is placed above the sensing zone, and a cement-bentonite grout is placed above the bentonite seal to the ground surface. Many designers perceive that a bentonite seal is needed to protect the sand from being disturbed during grouting. However, if the sand zone is saturated, a well-designed grout with a creamy consistency will only penetrate the sand a few inches (Mikkelsen, 2002). Therefore, an alternative and simpler procedure for backfilling open-standpipe piezometers is to grout the annulus above the sand zone with cement-bentonite grout to the ground surface. The grout should be placed using a tremie pipe to avoid bridging of

materials in small-diameter holes or for placement at a substantial depth below the water table. [Table 13.7](#) presents a typical mix design for cement-bentonite grout for medium-to-hard-soil and soft-soil applications.

The sensing zone where pore pressure measurements are desired is typically a section of slotted pipe or an attached porous element for keeping granular filter material and soil/refuse from entering the piezometer. If a slotted zone is used, the slots should be sized using the criterion:

$$\text{Slot Width} \leq 0.5 D_{85} \text{ of surrounding material} \quad (13-1)$$

where:

D_{85} = the soil particle size on a grain-size plot for which 85 percent of the soil sample by weight is smaller.

A schematic illustration of an open standpipe piezometer is provided in [Figure 13.9](#).

Open-standpipe piezometers are often constructed using 2-inch-inside-diameter, flush-coupled, Schedule 80 PVC or ABS pipe with either cemented or threaded couplings that permit easy passage of an electrical or mechanical reading device for measuring the water level. When cemented couplings are used, one end of each pipe length should be machined as male and the other as female so that the coupling can be connected using a solvent cement. When threaded couplings are used, they should be self-sealing so that a watertight connection is achieved without any sealer. Smaller-diameter pipe may be used (a minimum diameter of 1 inch is recommended for operation of water level measurement equipment), but that may limit the ability to flush the piezometer or to conduct other measurements such as falling-head hydraulic conductivity tests or to obtain water samples. As the annulus around the standpipe is backfilled, the pipe should be maintained as straight as possible to avoid difficulty in lowering measuring devices to determine the level of the water surface.

In addition to using slotted PVC pipe in sensing zones, manufactured porous piezometer screens that admit water but not particulate matter may be used. The two most frequently used types are metal well points commonly used for shallow dewatering and porous tips specially made for piezometers, such as the Casagrande-type piezometer tip. In fine-grained deposits where electrolytic action may bring about formation of gas that can increase the lag time of a system or where water chemistry may cause corrosive damage, the use of nonmetallic piezometer tips is advisable. The Casagrande-type

TABLE 13.7 CEMENT-BENTONITE GROUT MIX

Materials	Grout for Medium to Hard Soils ⁽¹⁾		Grout for Soft Soils ⁽²⁾	
	Weight	Ratio by Weight	Weight	Ratio by Weight
Water	30 gal	2.5	75 gal	6.6
Portland Cement	94 lb (1 sack)	1	94 lb (1 sack)	1
Bentonite ⁽³⁾	25 lb (as required)	0.3	39 lb (as required)	0.4

Note: 1. The 28-day compressive strength of this mix is about 50 psi, similar to very stiff to hard clay. The modulus is about 10,000 psi.

2. The 28-day compressive strength of this mix is about 4 psi, similar to very soft clay.

3. Water and cement should be mixed prior to the addition of bentonite; sufficient bentonite (as required) should result in a smooth, thick mixture like thick cream or pancake batter.

(MIKKELSEN, 2002)

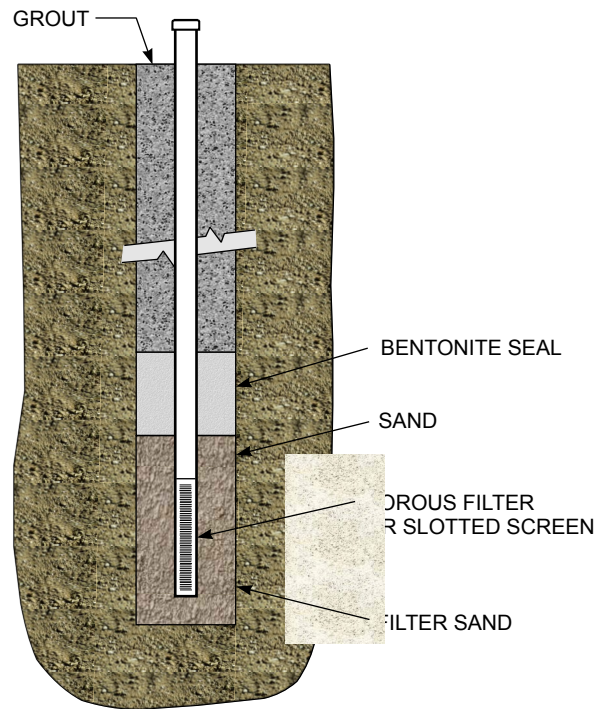

(DUNNICLIFF, 1993)

FIGURE 13.9 OPEN-STANDPIPE PIEZOMETER/OBSERVATION WELL

piezometer tip, for example, consists of a one- to two-foot-long porous ceramic tube that can be connected to various sizes of riser pipe.

Continuous experienced supervision should be provided in order to maximize the potential for successful piezometer installation. Because of continuing construction activities at coal refuse embankments and the long service life, it is common to encounter loss of functionality or damage to piezometers, leading to a need for repair or replacement. At critical locations, particularly where access may be a concern, multiple installations should be considered.

Following the installation of an open-standpipe piezometer, measurements should be taken to verify that the piezometer is functioning as expected, and the top should be protected against accidental damage or vandalism. The hydraulic response of open standpipe piezometers can be checked by:

- Bailing or evacuating water from within the piezometer riser pipe and letting groundwater re-enter through the sensing zone (rising-head test)
- Adding water to the piezometer riser pipe and letting water flow out from the piezometer sensing zone (falling-head test)
- Inserting a solid rod into the standpipe and forcing water flow out from the piezometer sensing zone (slug test)

Selection of a method to check piezometer response depends on the depth of the sensing zone below the ground surface and the availability of an adequate supply of clean water to conduct a rising- or falling-head test. In general, rising- or falling-head tests are conducted when the groundwater level is shallow and clean water is readily available. If the water level is deep (greater than 50 feet) and/or an adequate water supply is not available, a slug test is typically used. ASTM D 4043, "Standard Guide for Selection of Aquifer Test Method in Determining Hydraulic Properties by Well Techniques," should be followed for selection of suitable methods for checking the hydraulic response of open-

standpipe piezometers. Care should be taken in using the results of slug tests to determine hydraulic conductivity of coarse-grained soils. Herzog (1994) reports that four commonly used methods to determine hydraulic conductivity in coarse-grained soils can yield results that differ by up to two orders of magnitude. By contrast, in fine-grained soils, the analytical method used to interpret slug tests typically results in consistent values of hydraulic conductivity.

If the material in which the piezometer tip is located is relatively permeable, these tests can often be conducted shortly after installation, because the flow into or out of the piezometer should occur rapidly. The procedure simply consists of: (1) reading the water depth; (2) changing the depth by bailing, adding water or inserting a slug; and (3) periodically reading the depth to determine the time required to return to the original measured level. Much greater care is required when the piezometer tip is located in a low-hydraulic-conductivity material and the flow of water is slow. In this situation, the test should be delayed until the system stabilizes following installation. Then only slight changes in level should be made; otherwise, the time for stabilization may interfere with required readings for which the piezometer was installed in the first place. A piezometer is considered to be developed when repeated testing results in nominal sediment detection in the sensing zone and when rising or falling head tests produce consistent results. Once operational, response tests should be conducted whenever the accuracy of readings from a piezometer is in doubt (e.g., readings are inconsistent with readings from other piezometers).

Figure 13.8 provides guidance regarding the approximate response times for various types of open- and closed-system piezometers as a function of the hydraulic conductivity of the soil surrounding the sensing zone of the piezometer. As shown in the figure, the response time to achieve 90 percent equilibration increases with decreasing hydraulic conductivity and with increasing volume of the sensing zone (i.e., open-system piezometers are less responsive than closed-system diaphragm piezometers with pneumatic or vibrating wire systems). Hydraulic systems introduce additional delay in response time, associated with the length of tubing from the sensor to the readout location. Methods for estimating the response time are presented in Terzaghi and Peck (1967).

Open standpipe piezometers have often been lost due to debris dropped into the standpipe that either clogs the tip or precludes lowering of the water level measuring device. A grouted-in steel pipe with a removable cap can be installed at the top of the piezometer to protect temporary or permanent installations from accidental loss due to debris.

When an open-standpipe piezometer is installed in an area where the embankment height periodically increases, the riser pipe will need to be raised as fill is placed. To minimize the potential for surface water ponding and infiltration along the riser pipe/soil interface, the ground surface around the riser pipe should be elevated such that surface water drains away from the pipe.

Water levels in standpipe piezometers can be measured by a variety of methods, but the most common approach is an electrical water level meter. These devices typically consist of a two-conductor cable with a cylindrical stainless steel weight at the lower end. The weight is divided electrically into two parts and separated by a plastic bushing, and a conductor is connected to each part. The upper end is connected to a battery and a buzzer, light or ammeter. When the weighted probe is lowered into the piezometer, an electric circuit is completed when the probe encounters the water surface. The water depth is measured using permanent depth markings on the cable. Cable lengths over 1000 feet are available, but a probe with a 300-foot-long cable is usually sufficient for most coal refuse facilities. Special versions of these probes include features to measure temperature and conductivity. Other options for water level depth measurement include a weighted tape measure (for shallow-depth piezometers only), pressure transducer ([Appendix 13A.2.4.3](#)), ultrasonic transducer, and float and recorder system. Transducer and float/recorder systems are typically used with remote monitoring systems.

13.2.2.4 Closed-System Piezometers

Closed-system (pressure-transducer) piezometers have application when:

- Fine-grained material is being monitored such that response times for open-system piezometers would be too large.
- Remote readout is desired in order to minimize potential interference with and damage from earthwork equipment.
- Remote readout is desired so that measured piezometric levels can be integrated with data from other remotely monitored instruments.
- The material being monitored is not completely saturated.

Figure 13.8 provides guidance regarding the approximate response times for closed-system piezometers as a function of the hydraulic conductivity of the soil surrounding the sensing zone of the piezometer. As shown in the figure, the response time to achieve 90 percent equilibration increases with decreasing hydraulic conductivity. Hydraulic systems introduce additional delay in response time, associated with the length of tubing from the sensor to the readout location. Methods for estimating the response time are presented in Terzaghi and Peck (1967).

While pore pressures in unsaturated materials are not normally monitored at coal refuse disposal facilities, measurements in fine-grained materials (e.g., fine coal refuse or fine-grained foundation soils) and remote monitoring are situations when closed-system piezometers should be considered. As with instruments used for deformation and movement measurements, pneumatic, vibrating wire and electrical resistance transducers are available for measuring pore-water pressures. These transducers are typically installed in a borehole and backfilled with granular soil around the sensing zone, a bentonite seal above the sensing zone, and a cement-bentonite backfill to the ground surface. Recently, installation of closed-system piezometers within fully grouted boreholes has gained attention, as subsequently discussed. This installation method eliminates the cumbersome installation of a sand pack and bentonite seal, facilitates the installation of several piezometers in a nested configuration, and has a lower cost and faster installation than the traditional approach.

Pneumatic piezometers have advantages where high thunderstorm activity is anticipated. However, if pneumatic piezometers are used, normally-closed transducers are preferred to normally-open transducers because less diaphragm displacement is required for measuring the pore-water pressure in the sensing zone (Dunnicliff, 1993). The transducers are typically housed in corrosion-resistant plastic or stainless steel. A normally-closed pneumatic piezometer installation is illustrated in Figure 13.10.

Vibrating-wire piezometers have a metallic diaphragm separating the pore water from the measuring system (Dunnicliff, 1993). These devices are typically housed in stainless steel. Most vibrating-wire piezometers have a dried and hermetically-sealed cavity around the sensor to minimize the potential for corrosion, a thermistor to adjust for temperature effects, and some have an in-place check feature to account for zero drift and to permit in-service calibration. A vibrating-wire piezometer installation is illustrated in Figure 13.11.

Electrical-resistance piezometers are housed in stainless steel to resist the effects of lateral stresses on the device and to minimize corrosion. These devices are manufactured using semiconductor, unbonded and bonded electrical-resistance gages. An electrical-resistance piezometer installation is illustrated in Figure 13.12. These piezometers are constructed with an intake filter that separates the formation pore fluid from the diaphragm and sensor. The filter must be strong enough to not be damaged during installation and to resist embedment stresses without undue deformation. For coal refuse facilities, piezometers should be constructed using a coarse, low-air-entry filter that readily allows the passage of both gas and water. Typical low-air-entry filters have a pore diameter of 20 to

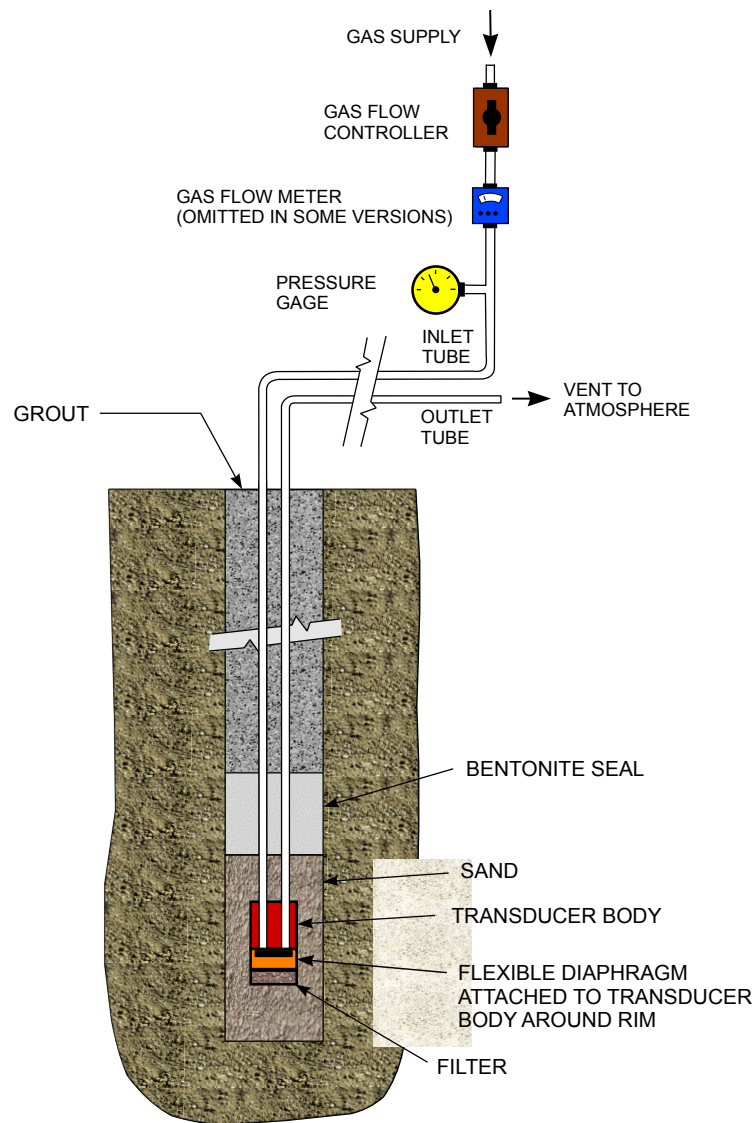

(DUNNICLIFF, 1993)

FIGURE 13.10 NORMALLY-CLOSED PNEUMATIC PIEZOMETER

80 microns (0.0008 to 0.0031 in) and air entry values ranging from 3 to 30 kPa (0.4 to 4.0 psi). Intake filters should be saturated prior to installation.

Contreras et al. (2007) have demonstrated the viability of directly surrounding diaphragm piezometers with cement-bentonite grout. Through computer simulation, laboratory testing, and field demonstration, they illustrated that a properly designed cement-bentonite grout mix will allow transmission of a low volume of pore water over a short distance (between the borehole wall and piezometer), yet maintain an overall low hydraulic conductivity in the vertical direction, thus isolating the instrument. The cement-bentonite grout should have a hydraulic conductivity of not more than 1,000 times the formation hydraulic conductivity to be effective, and trial mixes of typical water-cement-bentonite mixtures resulted in hydraulic conductivities between 10^{-5} and 10^{-7} centimeters per second. Note that the piezometers shown in Figures 13.10, 13.11 and 13.12 could also be installed using full grouting as described by Contreras et al. (2007).

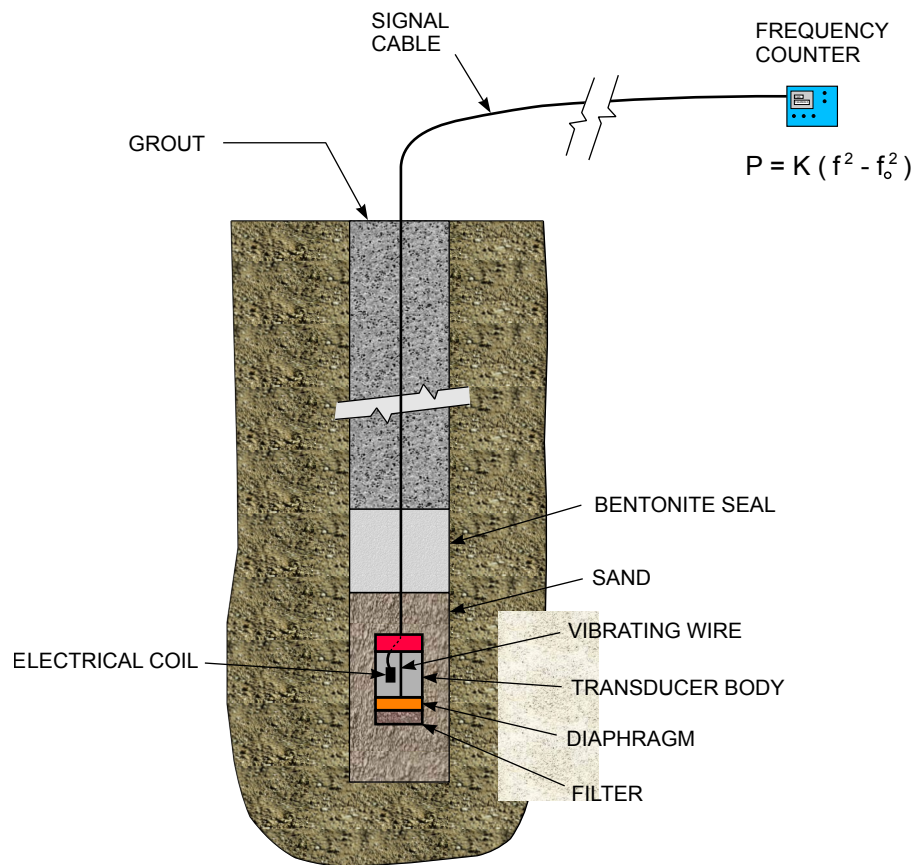

(DUNNICLIFF, 1993)

FIGURE 13.11 VIBRATING-WIRE PIEZOMETER

13.2.3 Surface Water Flows and Hydrologic Parameters

Monitoring of surface flows at a coal refuse facility site has the following purposes:

- To develop an understanding of seepage flows, either through, beneath or around an embankment and to evaluate the significant changes as the embankment configuration changes with time.
- To detect an unusual change in seepage quantity that may be an indicator of a developing seepage/stability problem.
- To determine discharges associated with runoff from storms for hydrology/hydraulic analyses and for environmental purposes.
- To determine discharges from mines with workings in proximity to an impoundment.

Monitoring of flows from coal refuse embankments through visual observation should be routine for all coal refuse disposal facilities, and quantitative monitoring of seepage through instrumentation or direct measurement should be performed during construction and operation of impoundments. Monitoring of surface runoff occurs much less frequently and usually is performed only when there are concerns related to flow diversion.

13.2.3.1 Measurement of Impoundment Water Level

Frequent monitoring of the water level at a coal refuse facility impoundment is important because:

- The pool elevation can change rapidly with time due to runoff from rainfall, spring flow from the watershed, inflow from the processing plant, increases in the level of settled solids, outflows through the decant and spillway systems, and seepage through the embankment.
- The level of water in the impoundment directly affects the rate of seepage flow and the groundwater conditions (pore pressures, piezometric levels, moisture contents) within the embankment.
- Existing reservoir conditions should be regularly checked for comparison with the storage capacity and freeboard requirements in the approved design plan.

Several types of gages for measuring water level are available. The simplest instrumentation is a staff gage consisting of a calibrated rod driven or concreted into solid ground or attached to a structure such as a decant tower. A staff gage allows the reservoir water elevation to be quickly and accurately determined and recorded during regular impoundment inspections. The location of the calibrated rod must be chosen so as not to be affected by changes in facility configuration and deposition of fine refuse and to be easily accessible. Often, this can be best accomplished by installation of several short gage rods with overlapping elevation markings in a stepwise arrangement along the upstream reservoir slope or along the hillside above the reservoir.

Continuously recording gages use floats within a stilling well for measuring the water level. The sensitivity of these instruments to siltation and changes in the level of settled solids make their use unattractive at most facilities.

For any type of gage, an accurate datum must be established so that the monitored pool elevation can be related to the elevations of other facility components. Care should be taken to minimize the potential effects of settlement, tilting, sliding and/or sloughing on the gages.

13.2.3.2 Measurement of Seepage Flows and Other Surface Water Flows

13.2.3.2.1 Importance of Seepage Flows

Seepage flows normally occur in one or a combination of the following forms:

- Flows from internal drainage systems that collect water seeping through the embankment for controlled discharge at the downstream toe.
- Underdrain systems installed (normally at non-impounding facilities) for collecting and transporting groundwater flow from springs through a drain system to the downstream toe without infiltration into the embankment material.
- Very low volume seepages that may emerge on the downstream embankment face.
- Flows from concentrated spring areas along abutments or in the valley bottom downstream from the embankment including those connected to abandoned mines.
- General upwelling of water into a valley bottom over a wide area with no single concentrated location.
- Seepage into or out of mine workings in the vicinity of the impoundment area.

Seepage flow rates are an important indicator of the performance of a facility's seepage collection and control system, which is a critical element in the safety of an impounding embankment. An unusual reduction in seepage flow may indicate clogging of an internal drain, while an unusual increase may be a sign of internal erosion. Unusual changes in seepage quantities must be detected and further investigated, as they could lead to stability problems or even failure of the embankment. For this reason, seepage flow rates should be routinely monitored, especially at high and significant hazard potential impoundments.

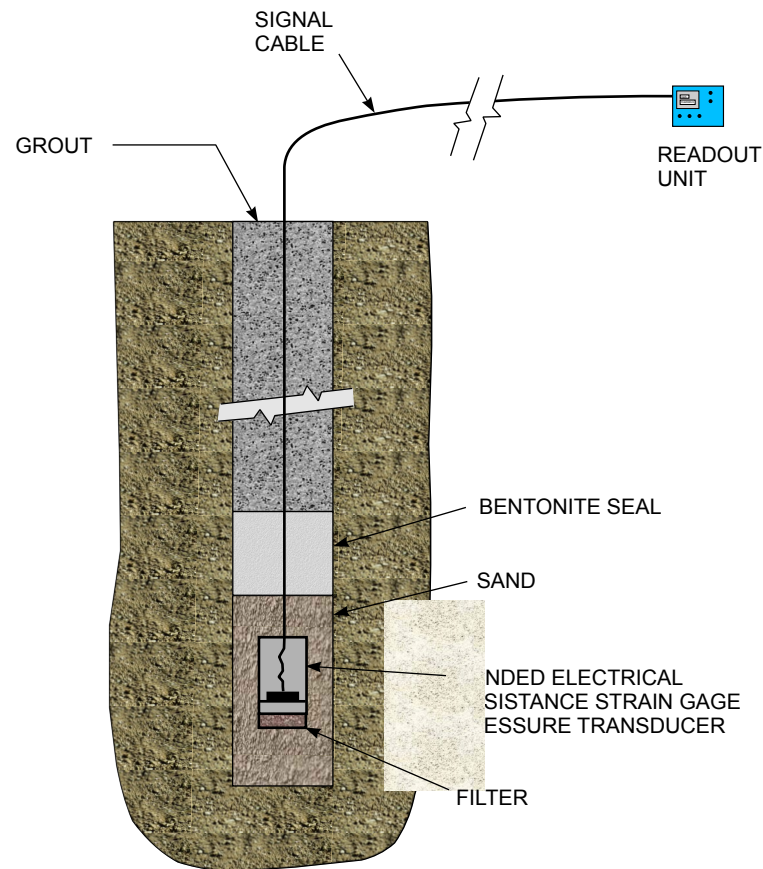

(DUNNICLIFF, 1993)

FIGURE 13.12 BONDED ELECTRICAL-RESISTANCE PIEZOMETER

Where seepage flows are through a pipe system, the flow volume normally can be monitored by:

- Collecting water in a calibrated bucket for a measured period of time.
- Calibrating the rate of flow versus the water depth in the discharge pipe.

Small seeps are normally monitored either by visual observation or by construction of small containments with discharge through a pipe. The discharge from the pipe can be collected in a bucket or the depth of flow can be correlated to the rate of flow. Large discharges downstream from springs or underdrains are usually monitored by a weir installed across the flow path. Widespread downstream seepage should be monitored during periods of dry weather when runoff from rainfall is not occurring. Flows can be measured at downstream culverts or by installing a weir at a point where all of the seeping water passes.

If collected seepage water must be treated prior to discharge, the treatment system may include a flow measuring device (e.g., flow meter, flume, continuous recorder) to control the rate of chemical additions or the retention time. These flow measuring devices can also be used for seepage rate monitoring.

The following characteristics of seeping water are useful for evaluation:

- Quantity of flow
- Temperature at the discharge point

- Quantity of suspended solids
- Water chemistry

Suspended solids in seepage can be an important indicator of piping, which could result in significant increases in seepage and even eventual impoundment failure. Determination of the presence of suspended solids is usually made subjectively by visual observation (e.g., the water is collected in a container and checked for fines), but if a developing problem is suspected, installation of sediment traps and/or quantitative testing may be necessary.

Evaluation of water chemistry can be an important indicator of the source of seeping water. For example, when seepage increases erratically with time, the source of the seepage may be associated with local groundwater conditions rather than the refuse facility impoundment. Comparison of the chemistry of the impounded water or groundwater samples to that of the seeping water can provide correlations for identification of the source of the seepage. However, determination of water chemistry represents a significant increase in the complexity of the monitoring program and generally is not performed unless other data indicate that it is needed. Wells completed in site geologic strata for monitoring the impact of the disposal facility on the natural groundwater can be useful for establishing local groundwater quality and evaluating seepage paths.

When required, pH, specific conductance, and dissolved oxygen can be measured with relatively simple field water quality testing equipment or continuous recording equipment. If other chemical analyses are required, water samples must generally be collected and subjected to laboratory analytical testing. Key indicators in areas where refuse disposal facilities are normally located include sulfate, total and ferrous iron, manganese, acidity/alkalinity, dissolved solids and suspended solids. The use of amendments with coal refuse disposal may suggest other key indicators (e.g., chloride for combustion waste).

13.2.3.2.2 Measurement of Seepage Flow Rates

The primary purpose for measuring seepage rates is to verify that the magnitude of seepage is reasonable in relation to the potential sources such as the upstream impoundment and local groundwater conditions that can vary with seasonal rainfall. The most important observed condition, and one that requires immediate attention, is when long-term relatively constant flows increase rapidly without a corresponding change in upstream conditions.

A number of methods for measuring flow from pipes have been developed and are described in the Water Measurement Manual (USB, 2001) or other textbooks on hydraulics such as Chow (1959) and Brater et al. (1996). These methods include, for example:

- Direct volume measurement using a calibrated bucket, pan or tank
- Calibrated weirs
- Flow nozzles and orifices
- Venturimeters
- Current meters
- Commercial water meters
- Flumes

For small flows, the simplest procedures for measuring the rate of flow are: (1) by filling a calibrated bucket during a measured time (volume per time) and (2) calculating the flow based on the geometry of the discharging water surface, provided the pipe discharges freely. [Figure 13.13](#) illustrates the following methods for measuring the flow rate at open-ended horizontal and vertical pipes:

- The California method (Figure 13.13a) for pipes not flowing full, where the measured trajectory and depth to water at the end of the pipe is used to calculate flow rate.
- The Purdue method (Figure 13.13b) is preferred for pipes flowing full or more than 50 percent full. For this method, the x and y coordinates of the discharge are measured, and empirical graphs provided by the USBR (2001) are used to determine the corresponding flow.
- The third method (Figure 13.13c) is used for estimating discharge from a vertical pipe. The rate of flow is determined from the curves presented on the figure based on the height of the jet and the inside diameter of the pipe.

Calibrated weirs are a simple and reliable means for monitoring flow. If a weir is being used to monitor seepage flow or discharge from a mine, the flow should not be comingled with surface runoff. A V-notch weir is frequently used for monitoring low flows because the decreasing width of the weir with decreasing flow maximizes the height of flow and enables an accurate determination. Situations where use of a V-notched weir is appropriate are presented in USBR (2001). If monitoring is required for only a short period of time, a V-notch weir can be as simple as a piece of exterior plywood (with the V-notch) installed into the ground to a sufficient depth and width that there is no seepage flow beneath or around the weir. The disadvantage of this type of weir is that its life is very limited because of deterioration of the wood when exposed to water and weather conditions. Another alternative for this type of weir is construction of a concrete head wall with a plastic or steel plate forming the weir. For facilities where the water quality may have corrosive characteristics, the V-notch plate can be made of fiberglass or stainless steel to extend the useful life.

Figure 13.14 shows typical construction details for a concrete weir with an attached plate, and Table 13.8 summarizes necessary conditions for accurate measurement for sharp-crested weirs (USBR, 2001). Two important construction details for V-notched weirs are: (1) sealing of the entire upstream side of the weir so that no water flows under or around the weir and (2) placing sufficient riprap or other channel protection downstream to prevent erosion in the area where the weir discharges.

To avoid flow restriction, a free-fall condition where the nappe does not cling to the downstream side of a weir should occur. However, under field conditions, it is sometimes difficult to locate a weir so that a free-fall condition will occur at all discharges. Figure 13.15 provides formulas and a series of curves for estimating flow through a V-notch weir under free-fall conditions (design conditions), as well as an approximate method for estimating flow with downstream submergence of up to 90 percent of the depth of flow through the weir. If the weir will be frequently submerged and accurate measurements are necessary, modifications to the weir structure may be necessary. When tables or graphs are used to determine the flow rate over weirs, care must be taken that the water measurement location and weir type match the conditions for which the tables or graphs were developed.

A rectangular weir should be used when relatively large flows are anticipated and should be designed by an engineer with experience related to weirs. The larger potential flows make construction details for a rectangular weir very important if excessive erosion and undercutting that could destroy the weir during high flow periods are to be avoided. The rate of flow over a rectangular weir is a function of the weir length and width and the shape of the crest and sides. Calibration of a rectangular weir should be performed in the field. An approximation of flow rate is given by the following formula (USBR, 2001):

$$Q = C_e L_e H^{3/2} \quad (13-2)$$

where:

$$Q = \text{discharge (length}^3/\text{time)}$$

$$C_e = 3.22 + 0.4 (H/P) \text{ for } L/B \text{ equal to 1 (weir constant)}$$

- L_e = equivalent length of weir, approximately equal to weir length L (length)
 H = measured head on the weir (length)
 P = crest height of weir (length)
 B = average width of approach to weir (length)

Refinements in estimating the effective coefficient of discharge (C_d) for other values of L/B are presented in USBR (2001). Other types of weirs have been used and are appropriate if designed and installed in accordance with the intended use. These types of weirs are discussed in the standard references on hydraulics, such as USBR (2001), Chow (1959), and Brater et al. (1996).

13.2.3.3 Measurement of Rainfall and Snowfall

Local precipitation data are needed at impoundment sites where differentiation of reservoir seepage from other sources is important. This need may occur at impoundment sites where underground mines are located below or near an impoundment and where it may be critical to monitor the rate and volume of water that can infiltrate the mine workings and affect mine breakthrough potential. Rainfall data may also be useful in evaluating how groundwater flow contributes to abutment seepage. Often, data from nearby meteorological stations operated by the U.S. Weather Bureau can be used for estimating precipitation at a site. However in mountainous regions or where the density of existing stations is low, rainfall and snowfall at a refuse disposal facility can vary significantly from measurements at meteorological stations. At these sites, simple precipitation measuring gages can be installed for daily measurement and recording of precipitation. If more information is required or if site personnel are not available to record daily measurements, a more sophisticated monitoring system with continuous recording may be appropriate. Standard equipment and procedures for monitoring climatic conditions are discussed by Linsley et al. (1982).

13.2.3.4 Observation of Temperature and General Weather Conditions

Whether a precipitation station is established or not, monitoring of temperature and general weather conditions (e.g., cloudy, sunny) should be performed at a refuse disposal site. This information is often useful when reviewing periodic inspection reports, assessing requirements for maintenance or evaluating unexpected conditions that have occurred.

13.2.4 Miscellaneous Instrumentation and Monitoring

The most commonly used monitoring instruments are those for measuring static displacements, pore-water pressures and water flow, as discussed in the previous sections. Other, less often used but frequently necessary, instrumentation is discussed briefly in the following subsections.

13.2.4.1 Measurement of Soil Pressure

Soil pressures on structures such as conduits installed under and through embankments are important. Two types of instruments for measuring total stress in soil are available: embedment cells and contact earth pressure cells (Dunncliff, 1993). Embedment earth pressure cells are used to measure total stress in a soil mass, but these instruments are beset with problems that render most measurements useless. Most of the problems are attributable to errors associated with conformance between the cell and the surrounding soil mass. Dunncliff (1993) describes these problems in detail. If the total soil pressure at points in a refuse embankment is needed for verification of design assumptions, field measurements of the in-place density should be considered in lieu of measuring total pressures with embedment pressure cells. For situations where data on the performance of a conduit is desired, monitoring of the internal deformation of the conduit will likely produce more useful results. [Section 12.2](#) provides guidance for monitoring the performance of deeply buried conduits with respect to the effects of earth pressure. Conduit deflection measurements can be obtained with laser or optical equipment using the laser ring method.

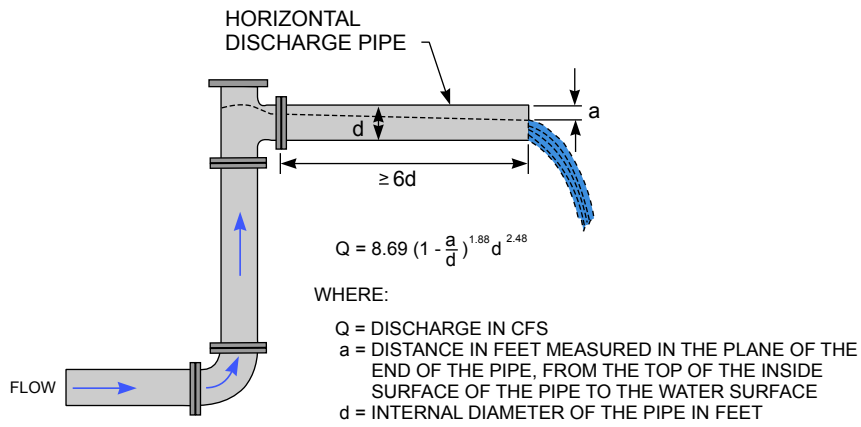

13.13a TYPICAL ARRANGEMENT FOR MEASURING FLOW BY THE CALIFORNIA PIPE METHOD

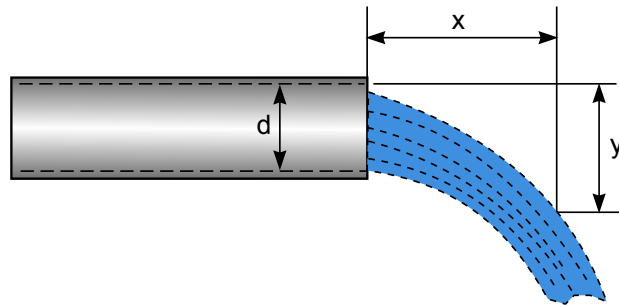

13.13b PURDUE METHOD OF MEASURING FLOW FROM A HORIZONTAL PIPE

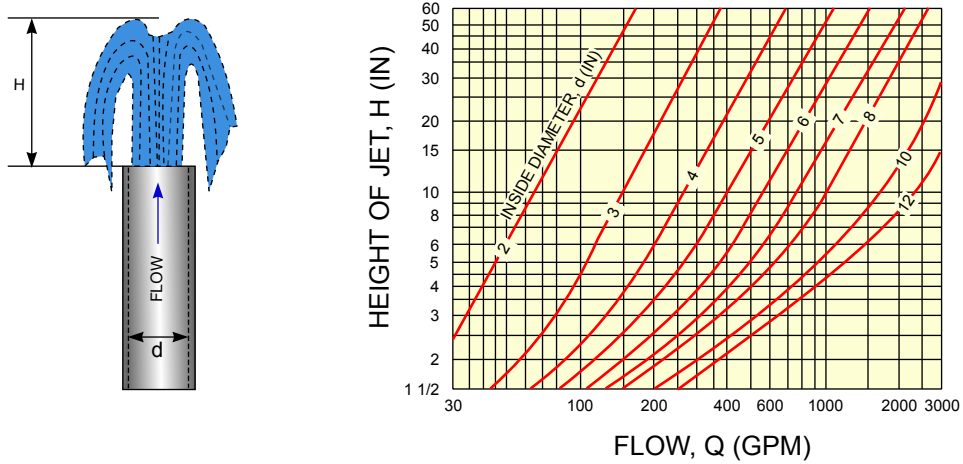

13.13c DISCHARGE CURVES FOR MEASUREMENT OF FLOW FROM VERTICAL STANDARD PIPES

FIGURE 13.13 MEASUREMENT OF FLOW FROM PIPES

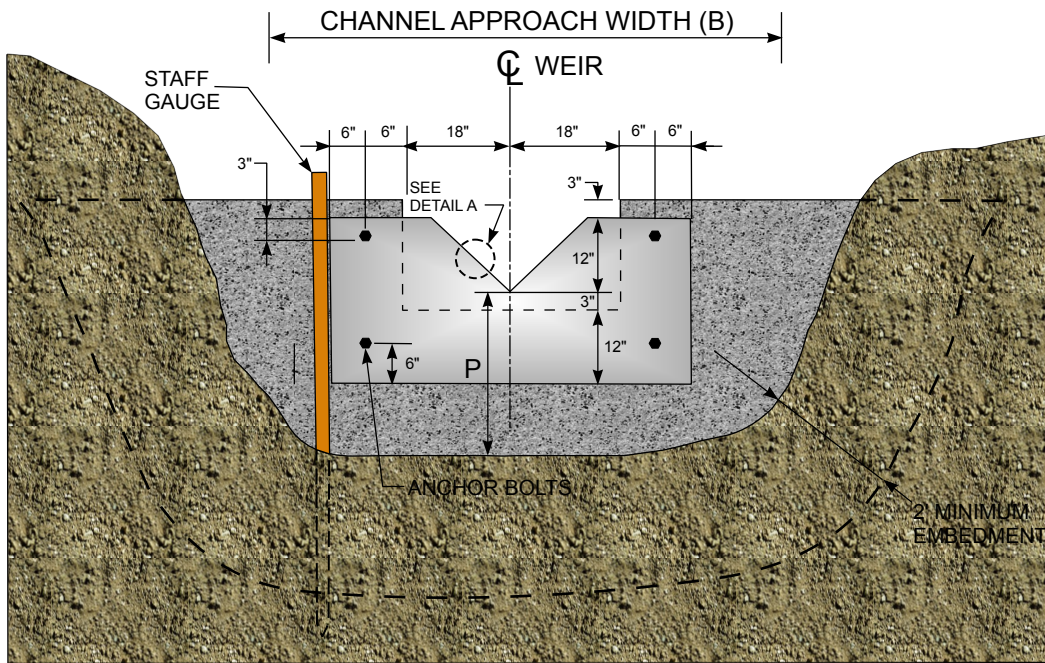
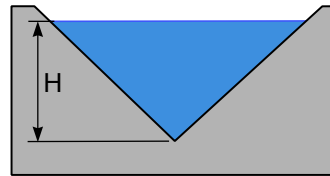
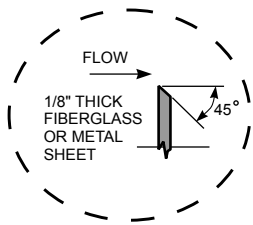
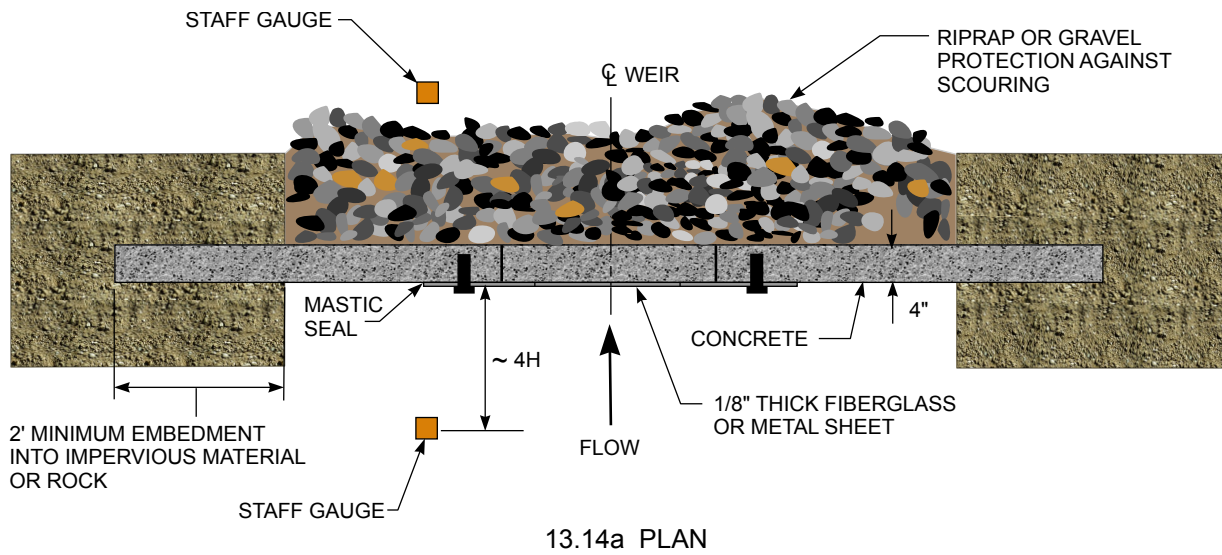

FIGURE 13.14 TYPICAL V-NOTCH WEIR

TABLE 13.8 GUIDANCE FOR ACCURATE WEIR FLOW MEASUREMENT

1.	The upstream face of the weir plates and bulkhead should be plumb, smooth, and normal to the axis of the channel. Weir plate fasteners should be located and installed in a manner that minimizes effects on the flow and water surface.
2.	The entire crest should be level for rectangular shapes, and the bisector of V-notch angles should be plumb.
3.	The edges of the weir opening should be located in one plane, and the corners should have the specified angles.
4.	The top thickness of the edges of the crest and side plates should be between 0.03 and 0.08 in.
5.	All weir plates should have the same thickness for the entire boundary of the overflow crest. If the plates are thicker than specified in Item 4 above, the plate edges should be reduced to the required thickness by chamfering the downstream edge of the crest and sides to an angle of at least 45 degrees; an angle of 60 degrees is highly recommended for a V-notch to help prevent water from clinging to the downstream face of the weir.
6.	The overflow sheet or nappe should touch only the upstream faces of the crest and side plates. Low flow conditions (< 0.2 ft of head) may result in the nappe clinging to the downstream weir face. If such conditions are sustained and accurate measurements are required, a reduced-size weir may be needed.
7.	The measurement of head on the weir is the difference in elevation between the invert of the weir and the water surface at a point located upstream from the weir a distance of at least four times the maximum head on the crest.
8.	Approach flow conditions should be fully developed, mild in slope, and free of curves, projections and waves. The approach flow velocity should generally be less than 0.5 ft/sec.

(ADAPTED FROM USBR, 2001)

Contact earth pressure cells can be used to measure total soil stress against a buried structure such as a wall or conduit. These instruments do not experience the problems associated with embedment cells, and it may be possible to measure total stress at the face of a structure with reasonable accuracy if issues of cell stiffness and temperature are considered during the instrumentation planning process. Dunnicliff (1993) recommends that diaphragm cells used for this application have two active faces (i.e., pressure is measured both on the cell face against the structure and on the face against the soil fill) and that hydraulic-type cells be avoided because they cannot be mounted flush with the structure face. Even if these guidelines are followed, however, considerable attention must be given to the number of cells needed, laboratory calibrations, temperature effects, cell stiffness, irregularities on the structure face, and a number of installation details. Therefore, if project requirements demonstrate a need for earth pressure measurements, earth pressure cells should be used with caution and with modest expectations for the outcome.

13.2.4.2 Measurement of Blast Vibrations

Portable seismographs are generally used for isolated cases where vibrations associated with blasting could affect structures of interest. The seismograph sensors are either accelerometers or velocity transducers that produce a record of the motion with time, usually in the form of particle velocity, although particle displacement and particle acceleration measurement are also possible. Velocities are measured triaxially (i.e., with respect to vertical, longitudinal and transverse axes) at the location where the instrument is anchored. If multiple instruments are installed at a site, they should be aligned in the same direction (e.g., with the longitudinal axes parallel to the long axis of the impoundment). Field instruments can be set to trigger at a specified velocity and can record and store hundreds of events that can then be downloaded to a personal computer or transmitted to a remote location. The frequency content of blast vibrations is typically much higher than would affect a coal refuse or earth dam. In most cases, blast monitoring is undertaken at surface structures (i.e., near local buildings) to verify that the blast ground motions do not exceed permissible standards. [Section 6.6.7](#) addresses blasting impacts.

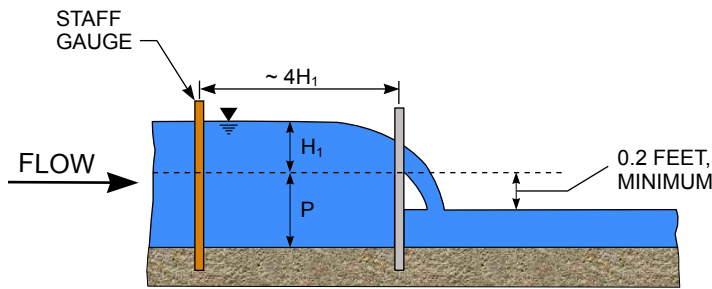
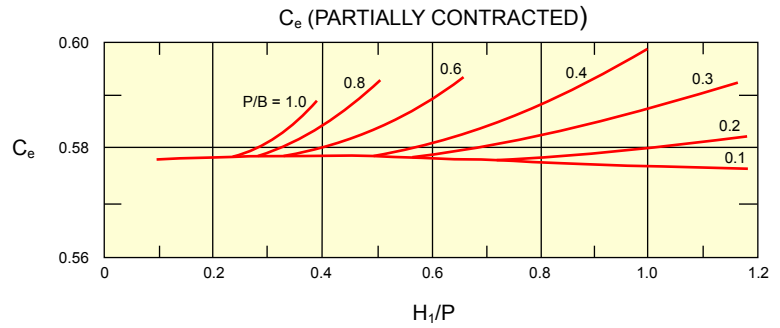
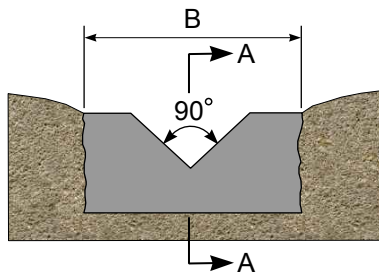

$$Q = 4.28 C_e H_1^{5/2}$$

$$C_e = 0.58 \text{ (FULLY CONTRACTED)}$$

EQUATIONS FOR DESIGN DISCHARGE

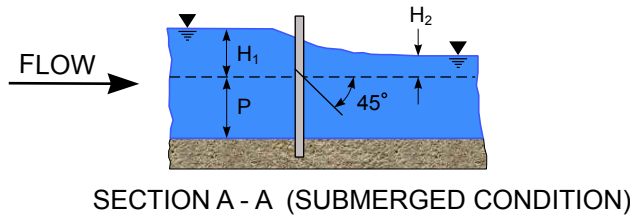

$$Q = KCH_1^n$$

$$K = \left[1 - \left(\frac{H_2}{H_1} \right)^n \right]^{0.385}$$

$$C \sim 2.52$$

$$n \sim 2.47$$

$$\frac{P}{H_1} > 1$$

EQUATIONS FOR SUBMERGED DISCHARGE

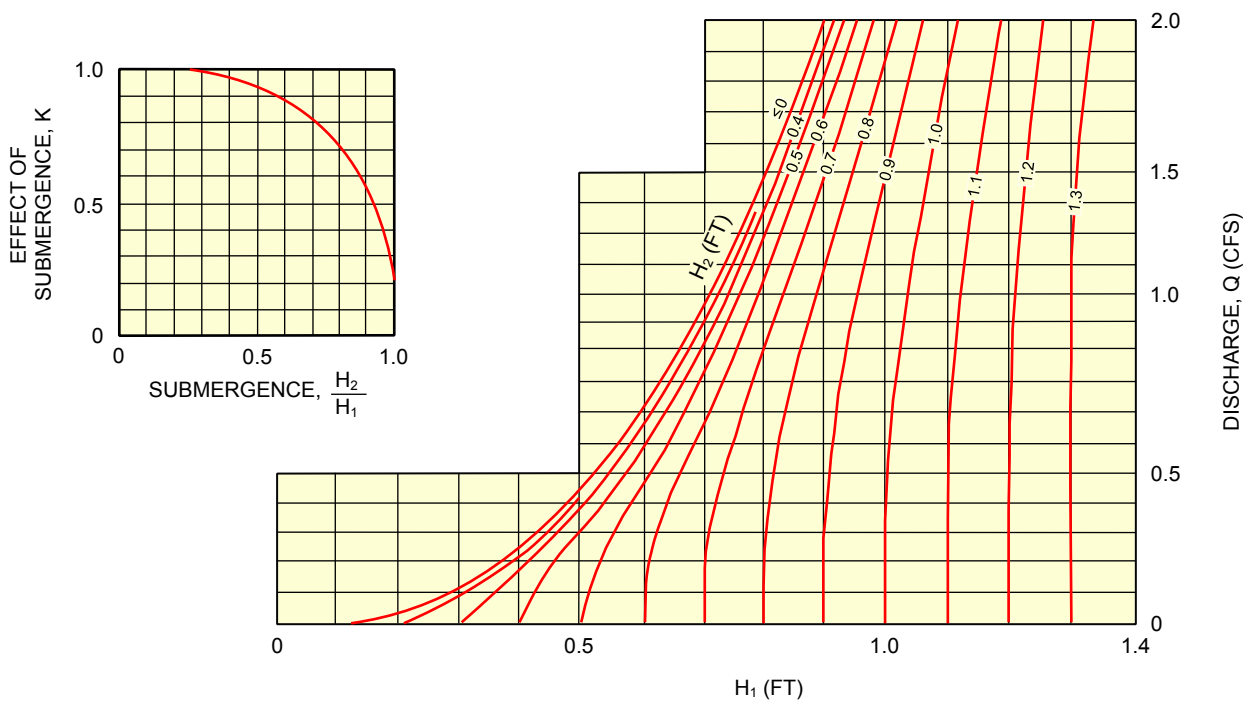

FIGURE 13.15 FLOW DEPTH–DISCHARGE RELATIONSHIP FOR 90-DEGREE, V-NOTCH WEIR

13.2.4.3 Measurement of Temperature

Evaluation of the extent of (or potential for) burning in a refuse embankment or in coal seams requires monitoring of temperatures at and below the ground surface. Internal temperature can be monitored by permanently-installed thermocouples on probes driven into an embankment. Also, temperatures in an embankment or in abutment coal seams can be measured by lowering conventional thermometers or telethermometers (remote sensing thermometers) down boreholes or piezometer standpipes.

Evaluation of surface temperatures over large areas can also be performed using remote sensing technology, including thermal imaging. Aircraft-mounted thermal imaging can cover very large areas and can detect minor variations in the ground surface temperature, which can assist in site characterization and on focusing subsurface exploration efforts.

13.3 INSTRUMENTATION MAINTENANCE

While a functional and reliable instrumentation system can be achieved with proper instrument design and installation, the system must be maintained so that it will continue to be functional and reliable in service. This section provides a discussion of general maintenance and recalibration practices.

13.3.1 Importance of Maintenance and Recalibration

Careful attention to factory calibration, pre-installation acceptance tests, installation, and post-installation acceptance tests should result in an instrumentation system that performs in accordance with expectations. To keep instruments operating satisfactorily during their service life, regular maintenance and recalibration are required. Lack of regular maintenance and recalibration can result in erroneous data that can lead to incorrect conclusions regarding facility performance. Lack of maintenance can also jeopardize the functioning of an instrumentation system leading to the loss of instruments. Malfunctioning or damaged instruments will normally need to be replaced or repaired.

Maintenance and recalibration activities should be conducted in accordance with a plan for regular instrument calibration and maintenance, as described in Step 8 in [Table 13.1](#). Maintenance procedures should be based on the manufacturers' instruction manuals and on-site conditions, as indicated in the design plans. These procedures should include preventative maintenance program schedules, troubleshooting, cleaning, drying, lubricating, battery servicing, and repair and replacement instructions for each type of instrument. Maintenance and recalibration should be the responsibility of personnel responsible for instrument monitoring, and it is essential that these individuals be knowledgeable about the types, expected and actual performance, and the maintenance and recalibration requirements of the instrumentation and data acquisition systems for the facility.

Personnel responsible for instrumentation maintenance and recalibration should be reliable, dedicated, and motivated individuals who pay attention to detail. They should have a background in the fundamentals of geotechnical engineering and should understand mechanical and electrical equipment. They should understand the purpose of instrumentation and how the instruments function. Maintenance and recalibration of instrumentation should be supervised by the data collection personnel, who are most likely to notice potential problems and to observe malfunctions, deterioration, or damage.

A service history record of maintenance, recalibration, repair, and replacement of the components of the instrumentation system should be maintained, and this record should be reviewed by the personnel responsible for evaluating facility performance. The service history should include dates, observations, problems that occurred, measures taken, and the personnel who were involved. A service history documents the general behavior of the instrumentation system and can serve as a guide to future maintenance activities. The service history also facilitates the transfer of responsibility associated with turnover in personnel.

Spare parts and interchangeable components should be available for replacing failed or questionable instrument components without interrupting system operation. An inventory of spare parts and instruments should be available and should be updated as necessary. Spare readout units should be available in the event of malfunction of the primary readout units.

13.3.2 Recalibration and Maintenance during Service Life

When instruments are in service, they require regular recalibration and maintenance if their normal operational characteristics are to be maintained. Generally, recalibration should be performed on a defined schedule, as documented in the Operation and Maintenance Plan. Routine recalibration of instrumentation system components is best performed by personnel responsible for data collection with the knowledge of personnel responsible for data analysis.

Instrumentation data should be carefully examined for indications that recalibration is needed. If abrupt changes or unexplained long-term trends in data are observed without apparent reason, the affected instrument should be checked to determine whether or not the data reflect actual conditions or are the result of instrument malfunction. If a need for recalibration is indicated, procedures should follow the instrument manufacturer's recommendations. General guidelines for the recalibration and maintenance of geotechnical and structural instrumentation systems and associated data acquisition equipment are provided in USACE (1995c).

In addition to regular recalibration, weirs, flumes, or other water measurement devices require regular maintenance so that: (1) water does not bypass the device, (2) leakage around or under the device is sealed, and (3) sediment deposition has not altered the approach conditions for the device.

13.4 AUTOMATED DATA ACQUISITION

Automated data acquisition systems have been demonstrated to be reliable and cost effective for monitoring the performance of constructed works and their surrounding environment, especially at sites where access is difficult or where regular survey and/or monitoring control are not practical or economical. With time, automated data acquisition systems will continue to improve with the likelihood that their use at coal refuse facilities becomes more common. Where deployed at coal refuse disposal facilities, automated data acquisition systems have been generally used for monitoring impoundment pool and piezometer levels.

Most automated data acquisition systems are programmed to retrieve data from multiple instruments on a prescribed schedule, process the readings to present the results in terms of engineering dimensions, and store or transmit the data. System components and design are discussed in [Appendix 13A.4](#).

[Figure 13.16](#) illustrates the application of an automated data acquisition system at a coal refuse disposal impoundment for monitoring piezometer levels and transmitting the data to a mine office more than a mile away. Features such as data collection from multiple piezometers, radio transmission, data storage and distribution of data by e-mail have been incorporated into monitoring programs. Quaranta et al. (2008) discuss an automated data acquisition program used for collecting the following data at a coal refuse disposal facility: water level, pH, specific conductance, and temperature at piezometers; water discharge; and the impoundment pool level. Weather station data (ambient air temperature, barometric pressure, rainfall, and wind speed) were also collected. This reference presents the system design, equipment, and operation issues encountered.

13.5 INSTRUMENTATION COSTS

Instrumentation systems are typically employed at refuse embankments and dams for monitoring water levels, pore-water pressures, deformations, and other important parameters depending upon

site conditions. For below-grade instrumentation used on conventional geotechnical engineering projects, the initial purchase price of an instrument and the cost of installation represents 15 to 30 percent of the total instrument life-cycle costs, which also include periodic readings, maintenance, data analysis and interpretation, data management, and eventual decommissioning (McKenna, 2006). Based on experience from numerous instrumentation projects, McKenna (2006) concluded that the typical life-cycle cost for an instrument employed for conventional geotechnical engineering projects is about 15 times the initial purchase price. For coal refuse disposal facilities that can operate over very long periods, the initial price of an instrument may represent an even smaller percentage of the life-cycle costs. McKenna (2006) offers the following lessons learned:

- Lesson 1 – The best way to save money is to install instruments that are suited to the site-specific and performance conditions critical to the safe operation of the structure. This lesson reinforces several steps in the planning process that were discussed in [Section 13.1](#).
- Lesson 2 – The actual cost of the instrument is very small compared to the life-cycle costs, so instruments should be purchased with reliability in mind.
- Lesson 3 – Every instrument should be installed with care, should be maintained, and should be read by a trained and diligent technician in accordance with project quality control procedures.

Some additional thoughts on instrumentation are provided in the following:

- The greatest cost of instrumentation is obtaining the readings, and the greatest risk is the additional expense associated with poor quality or inaccurate readings.
- Instrumentation suppliers should be viewed as a partner in the complete process, especially for designers who have limited experience with instrumentation.

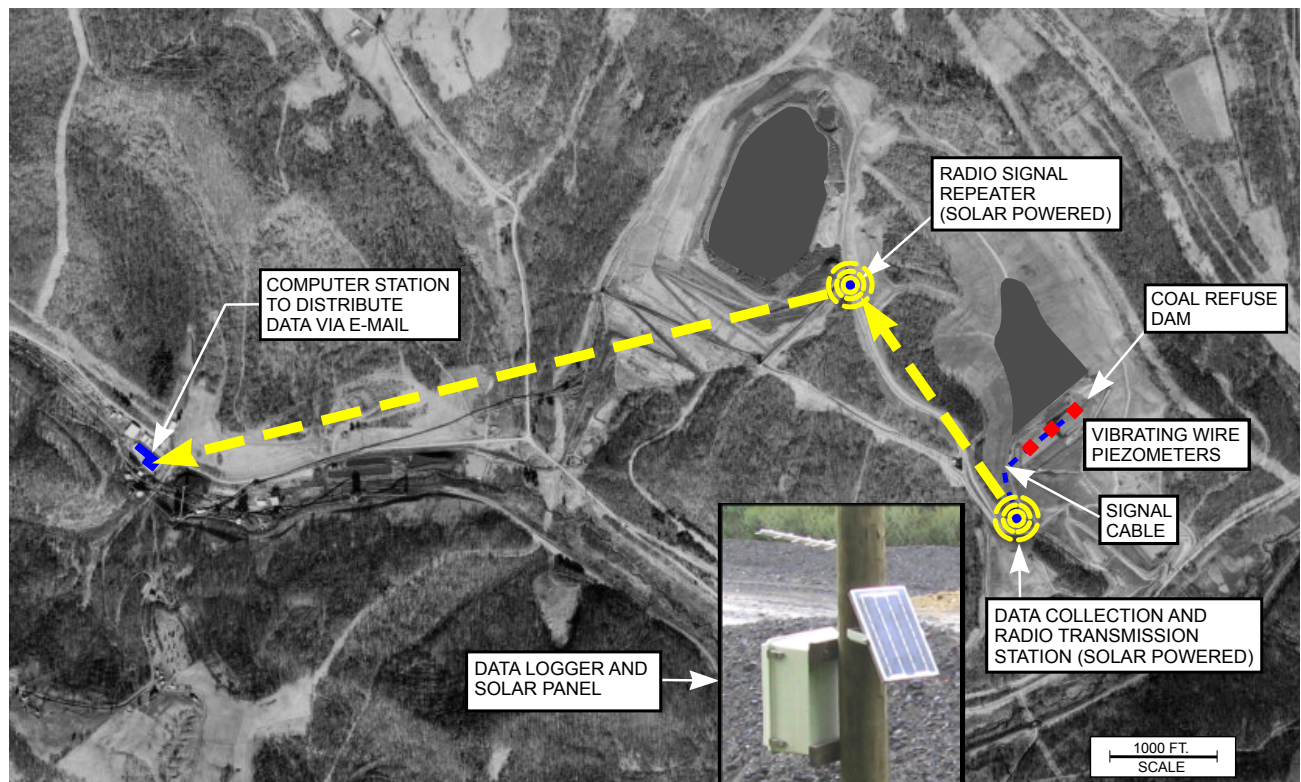

FIGURE 13.16 AUTOMATED DATA ACQUISITION SYSTEM AT COAL REFUSE DISPOSAL FACILITY

- Measures should be taken to see that data reading procedures are in place for each type of instrument, personnel are trained with respect to the procedures and equipment, readout equipment is properly maintained and regularly calibrated, and all raw data is recorded, plotted and evaluated according to project requirements.
- The same technician and equipment should be used to obtain all instrumentation readings to the extent possible. Automated data acquisition systems can improve the consistency and reliability of the data while providing more continuous monitoring.
- Instruments should be carefully protected because replacement can be difficult and costly.
- In areas where it would be particularly difficult to replace a failed instrument, redundant instruments should be considered.
- As time progresses, some opportunities for instrumentation system improvement may become apparent. Changes should be implemented, as needed, to improve the data gathering process and the quality of the data obtained.

This chapter has provided a discussion of the important aspects of implementing an instrumentation program at a coal refuse disposal facility including planning, instrument selection, installation, and data retrieval and processing. The benefits of well planned and properly installed and maintained instrumentation include:

- Enhancing the ability to compare the actual performance with the performance anticipated by the designer
- Enhancing the ability to recognize problem conditions before they become serious
- Aiding in the design and construction of expansion plans or remedial measures when they are needed

In summary, the cost of geotechnical instrumentation should be considered in context with the benefits that can be achieved, especially given the long in-service life of most coal refuse facilities.

Appendix 13A

MEASUREMENTS, TRANSDUCERS AND DATA-ACQUISITION SYSTEMS

This appendix provides information regarding measurements and measurement uncertainty, transducers and data acquisition systems supplementing the general discussion of these topics in Chapter 13.

13A.1 MEASUREMENT AND MEASUREMENT UNCERTAINTY

Quantitative measurements obtained by field instrumentation provide a means for confirming a safe and efficient design and verifying safe and economical construction. Because all measurements involve error and uncertainty, the measures by which error and uncertainty are defined should be considered as part of the field instrumentation design. The standard measures used to define error and uncertainty in instrument measurements include:

- Conformance is the ability of an instrument to measure performance without affecting the measurement. Similar to in-situ structures, instruments that are stiffer than the surrounding media tend to attract load while instruments that are softer than the surrounding media tend to shed or arch load away. Therefore, instrument behavior should match the behavior of the medium in which it is installed as closely as possible.
- Accuracy is the closeness of a measurement to the true value and is determined during calibration by comparison to the true value.
- Precision is the closeness of several measurements to the mean value and is synonymous with reproducibility. The difference between accuracy and precision is illustrated in [Figure 13A.1](#).
- Resolution is the smallest division on the instrument readout scale.
- Sensitivity is the amount of output response an instrument produces in response to an input quantity (e.g., 1000 millivolts per inch)
- Linearity refers to the proportionality between the indicated value and the actual value. Thus an instrument with a linearity of $\frac{1}{2}$ percent full scale means that the maximum error resulting from a linear calibration will be $\frac{1}{2}$ percent of the full-scale reading.
- Hysteresis is a property of systems that do not instantly respond to the forces applied to them, but react slowly, or do not return completely to their original state.
- Noise refers to random measurement variations caused by external factors that result in lack of precision or accuracy.
- Error is the deviation between the measured value and the true value. Types of errors include gross error, systematic error, sampling error and random error.

Measurement uncertainties must be considered as part of instrument selection and also in the evaluation of measurement data.

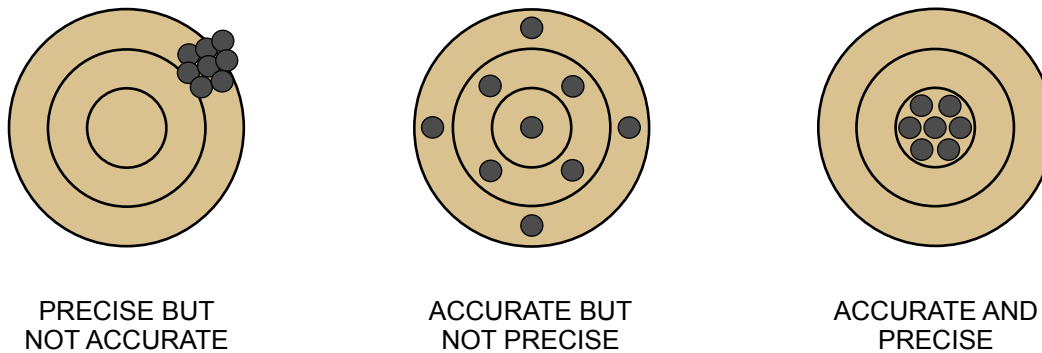

(DUNNICLIFF, 1993)

FIGURE 13A.1 GRAPHIC ILLUSTRATION OF ACCURACY AND PRECISION

13A.2 INSTRUMENT TRANSDUCERS

While performance monitoring at coal refuse facilities is typically conducted using position surveys of surface monuments and other devices such as staff gauges, inclinometers, standpipe piezometers, weirs, and rainfall gauges, geotechnical and structural instrumentation employing transducers is becoming more prevalent because these devices facilitate remote monitoring, transmission and processing of performance data. For such applications, instruments frequently consist of a transducer, data acquisition system and a communication link between them. A transducer is a device that converts a physical response or change into a corresponding output signal. Transducer types can be classified as:

- Mechanical
- Hydraulic
- Pneumatic
- Electrical

Measurement of geotechnical and structural behavior is typically accomplished using instruments employing more than one transducer type. The selection of an instrument appropriate for a particular application depends on the type of measurement required, the project setting and related environmental factors, and the duration for which measurements are required. Data acquisition systems for these instruments range from simple portable readout units to complex, automated systems.

13A.2.1 Mechanical Instruments

The most commonly used mechanical instruments are dial gages and micrometers. A dial gage converts the linear movement of a spring-loaded plunger to movement of a pointer against a dial scale. Accuracies are usually ± 0.001 inches or ± 0.0001 inches with a range of movement of typically 1 to 2 inches, although instruments with ranges up to 12 inches are available. Most dial gages are inexpensive, but they are somewhat fragile and can be affected by environmental factors such as dust and dirt. For long-term application, sealed and waterproof versions are available.

A micrometer functions by the rotation of a finely threaded measuring rod that moves into or out of a sealed housing. Movement of the rod is measured by a scale on the housing that indicates the number of revolutions. Fractional revolutions are determined using gradations marked around the rod and a vernier on the housing. Accuracy for micrometers reading in

inches is ± 0.001 inches. The rod length can be changed to permit a measurement range up to 6 inches, and digital outputs are available to overcome difficulties with reading vernier scales.

Dial gauges, micrometers and other simple gauges (e.g., crack monitors) have been used at dams and impoundments on mine sites where adverse conditions are suspected. Some applications have included monitoring crack apertures and relative displacements in or adjacent to rigid structures, such as concrete spillways or intakes and pipes.

13A.2.2 Hydraulic Instruments

Although not normally used for monitoring the performance at coal refuse facilities, the most commonly used hydraulic instruments are Bourdon-tube pressure gages and manometers. A Bourdon tube is a flattened tube that is coiled into a C-shape. When the tube is pressurized, the tube expands causing it to uncoil. The uncoiling motion is linked to a pointer that rotates over a circular scale. Bourdon tubes typically have an accuracy of ± 0.5 percent full scale for 4- and 6-inch-diameter dial gages, but gages with higher accuracy (e.g., ± 0.1 percent full scale) may be required for meeting project requirements, especially for long-term applications. Bourdon-tube gages are used with hydraulic piezometers, hydraulic load cells, borehole pressure cells, and some readout units for pneumatic transducers (Dunnicliff, 1993).

A manometer is a liquid-filled U-tube. The pressure on one side of the U-tube is balanced by an equal pressure on the opposite side. Manometers are used for long-term monitoring of very small positive or negative pressures and are easily calibrated and have a greater longevity than Bourdon tubes. Manometers are used with twin-tube hydraulic piezometers and liquid-level settlement gages (Dunnicliff, 1993). In these devices, the pressure difference between the liquid surfaces at the opposite ends of the manometer has a known relationship to the elevation difference via an assumed or measured density of the liquid. Potential problems with a manometer are discontinuity in the liquid due to formation of gas bubbles, changes in the density of the liquid due to temperature effects, and surface tension effects. Dunnicliff (1993) describes each of these problems and provides recommendations to prevent their occurrence.

Use of these instruments requires physical access to the readout location. If remote data recording is necessary, an electrical pressure gage should be used (Dunnicliff, 1993).

13A.2.3 Pneumatic Instruments

Pneumatic instruments function by supplying a known pressure via tubing that reacts against a sealed diaphragm in the pneumatic transducer. When the pressure in the inlet line just balances the pressure against the transducer diaphragm, the diaphragm displaces slightly. This condition is determined by a return of gas flow from the outlet line (for a gas-flowing instrument), or the pressure in the outlet line is measured using a Bourdon tube or electrical pressure gage (for a non-gas-flowing instrument). For simple applications, manually-operated readout units for pneumatic instruments are available. Where a large number of pneumatic instruments must be monitored, readout units can be connected to large gas tanks, and data acquisition and control systems can be used to energize the systems and to scan and record the measurements.

Important characteristics of most commercially available pneumatic transducers include sensitivity to diaphragm displacement, sensitivity to gas flow rate, and the length of tubing. For reliable performance: (1) transducer components should not be prone to corrosion, (2) a dry gas such as carbon dioxide or nitrogen should be used, and (3) the tubing and fittings should be air tight and impermeable to moisture infiltration. Pneumatic transducers and data acquisition systems are used in pneumatic piezometers, earth pressure cells, load cells, and liquid settlement gages (Dunnicliff, 1993).

Pneumatic piezometers are routinely used at coal refuse disposal facilities, primarily to monitor pore pressure within low-hydraulic-conductivity deposits that may exhibit elevated pore pressure when loaded. Specifically, these types of piezometers have been used to monitor pore pressures within fine coal refuse subject to upstream construction loading. When instruments for such an application are selected, their reliability and recommended service period should be evaluated.

13A.2.4 Electrical Instruments

13A.2.4.1 Electrical Resistance Gages

Electrical resistance gages are used for many geotechnical and structural monitoring applications. These gages are precisely manufactured conductors that change resistance in proportion to the change in length of the gage. Most strain gages have a nominal resistance of 120 or 350 ohms. The gage factor, which is a measure of the strain sensitivity of the gage, is typically about 2 for bonded foil and wire gages and between about 50 and 200 for semiconductor gages.

The bonded foil strain gage is the most widely used type, and it has significant advantages over all other types of strain gages. Bonded foil gages consist of a metal foil pattern mounted on an insulating backing or carrier, constructed by bonding a sheet of thin-rolled metal foil 2- to 5- μm thick on a backing sheet that is 10- to 30- μm thick. The measuring grid pattern including the terminal tabs is produced by photo-etching. Bonded foil gages are used because of the quality of their manufacturing and because the temperature characteristics of the gage can be matched to the material being measured. Higher resistance gages are preferred for transducer applications because such devices permit a higher voltage input that results in a higher voltage output and minimizes the effects of extraneous resistance changes. A variant of the foil gage is the weldable resistance strain gage, which typically consists of a foil gage attached to a thin stainless steel mounting flange. Strain gages can be used for long-term monitoring applications provided that methods used for gage installation, sealing, and protection are appropriate for the application.

The output from electrical resistance gages is generally measured using a Wheatstone bridge circuit, which is described by Dunncliff (1993). The circuit consists of four resistors arranged in a diamond orientation, as shown in [Figure 13A.2](#). An input DC voltage (excitation voltage) is applied between the top and bottom of the diamond, and the output voltage is measured across the middle. When the output voltage is zero, the bridge is “balanced.” One or more of the legs of the bridge may be a resistive transducer such as a strain gage. If the circuit has one strain gage, it is referred to as a quarter-bridge circuit. Similarly, if the circuit has two or four strain gages, the circuits are referred to as half-bridge and full-bridge circuits, respectively. For quarter- and half-bridge circuits, the other legs of the bridge are electrical resistors with resistance equal to that of the strain gage(s). Although half-bridge and quarter-bridge circuits are often used, the full-bridge circuit is the optimal configuration for strain gage usage. It provides the highest sensitivity and the fewest error components, and because the full-bridge circuit produces the highest output, noise is a less significant factor in the measurements. For these reasons, the full-bridge circuit is recommended. A full-bridge configuration is typically used for load cells (Dunncliff, 1993). In general, the primary application for resistance networks in geotechnical and structural instrumentation described in this Manual is for resistance strain gages used in piezometers to monitor dynamic pore water pressures (e.g., from rapid or cyclic loading) and also for measuring loads in structural elements such as rock bolts or permanent ground anchors for slope stabilization.

13A.2.4.2 Linear Variable Differential Transformer (LVDT) and Direct Current Differential Transformer (DCDT)

LVDTs and DCDTs consist of a moveable magnetic core passing through a primary and two secondary coils. An excitation voltage is applied to the primary coil that induces a voltage in the

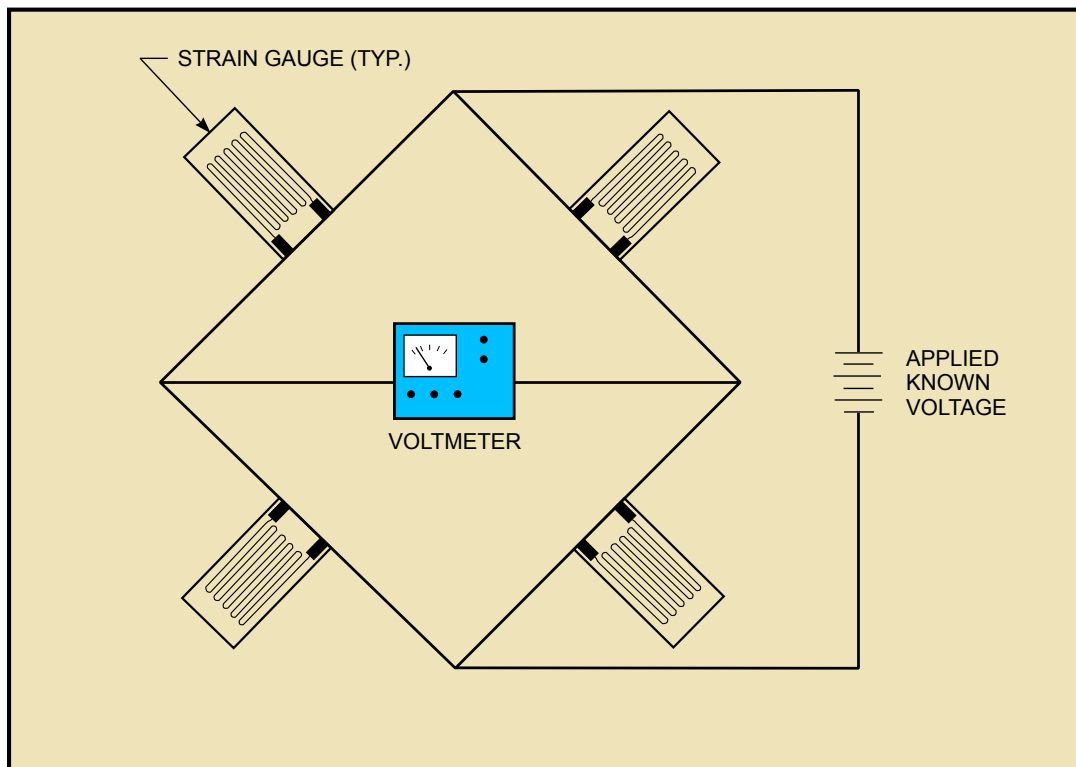

FIGURE 13A.2 WHEATSTONE FULL-BRIDGE NETWORK CONFIGURATION

secondary coils that is dependent upon the proximity of the magnetic core to each secondary coil. The secondary coils are connected in series opposition so that the net output from the device is the difference between the two voltages. When the core is located at the midpoint of the device, the net output voltage is zero. When the core moves from the midpoint, the net output voltage varies linearly. These devices have no hysteresis, and they are well suited for measuring very small displacements and dynamic movements. The primary difference between the two devices is that LVDTs are powered by an AC voltage while DCDTs are powered by a DC voltage. Also, DCDTs are provided with onboard oscillator, carrier amplifier, and demodulator circuitry while LVDTs require these components externally. DCDTs are preferred for geotechnical applications where specialized signal conditioning is not needed for amplifying output from the device. LVDTs and DCDTs are used in fixed borehole extensometers and other instruments to measure deformation (Dunncliff, 1993).

13A.2.4.3 Vibrating-Wire Transducer

The vibrating-wire transducer consists of a taut, ferromagnetic wire that is excited into transverse vibrations by a drive coil. These vibrations are detected using a pick-up coil. Both coils have permanent-magnet cores, and once the wire has been excited to its resonant frequency for a given tension, it is maintained at this frequency by connecting the two coils through an amplifier to form a self-oscillating system. Each resonant frequency is a measure of the tension in the wire and therefore the applied force. The advantage of the vibrating-wire transducer is that its direct frequency output can be handled by digital circuitry, eliminating the need for an analog-to-digital converter. Sources of error include wire corrosion, wire creep under permanent tension, and wire slippage at the anchoring locations, all of which usually result in a reduction in frequency.

The output from vibrating-wire devices is measured using the pluck and read method or the continuous excitation method. The pluck and read method involves applying one or more volt-

age pulses to the drive coil to cause the wire to vibrate. The coil then receives the signal from the vibrating wire and transmits the measured voltage to a frequency counter, which measures the time required for a selected number of vibration cycles. The continuous excitation method uses a similar procedure to initiate wire vibration, but uses a second coil to detect the frequency. The signal is fed back to the driving coil, which then applies a continuous pulsing voltage. As the wire frequency changes, the driving frequency also changes, and the new frequency is measured as described for the pluck and read method.

Vibrating-wire transducers are used in pressure sensors for piezometers, earth pressure cells, liquid level settlement gages, load cells, and directly as surface and embedment strain gages (Dunncliff, 1993). Vibrating wire piezometers are effective instruments for monitoring rapid pore pressure changes in fine coal refuse deposits during upstream construction and have also been used in standpipe piezometers to facilitate automated monitoring and data acquisition systems.

13A.2.4.4 Force-Balance Accelerometer

A force-balance accelerometer consists of a mass suspended in the magnetic field of a position detector. When the mass is subjected to a gravitational force along its measuring axis, the mass attempts to move and the motion induces a current change in the position detector. This change in current is relayed to a servo-amplifier connected to a restoring coil that imparts an electromagnetic force to the mass to resist movement. The current through the restoring coil is measured by the voltage across a precision resistor. The measured voltage is directly proportional to the input force. Force-balance accelerometers have exhibited good performance when used in portable tiltmeters and in inclinometers where the position of the transducer can be reversed to eliminate errors caused by zero shift.

13A.2.4.5 Magnetic Reed Switch

The magnetic reed switch is an on/off position detector used to indicate when conductive reeds are in a certain position with respect to a ring magnet. When a magnetic reed switch enters a sufficiently strong magnetic field, the reed contacts close and remain closed while they are in the magnetic field. Closure of the contacts normally results in activation of a buzzer and/or indicator light in a portable readout unit. Repeatability of the device depends on the radial position of the reed switch within the magnet. If the reed switch remains within the middle third of a 1¼-inch-diameter ring magnet, repeatability will be within ± 0.01 inches (Dunncliff, 1993). The device is simple, reliable, precise, inexpensive and well suited to long-term applications. The magnetic reed switch is used in probe extensometers.

13A.2.4.6 Induction-Coil Transducers

Induction-coil transducers function by supplying an AC source to a primary coil and measuring the voltage induced in a secondary coil that is located within the magnetic field of the primary coil. For geotechnical applications, inductive-coil transducers have been used to measure strain in soils and displacement in probe, fixed embankment, and borehole extensometers (Dunncliff, 1993). These devices have excellent long-term stability provided that the steel components are protected from corrosion.

13A.2.4.7 Other Types of Electrical Transducers

Other types of electrical transducers include the potentiometer, variable-reluctance transducer, magnetostrictive transducer, and the electrolytic level. These devices and their geotechnical and structural instrumentation applications are discussed in Dunncliff (1993). Information is also available from commercial geotechnical and structural instrumentation suppliers.

13A.3 SUPPLEMENTAL MOVEMENT-MEASUREMENT TECHNIQUES

Section 13.2.1.2 discusses the more commonly applied techniques for measurement of movements. This section discusses supplemental techniques including transverse deformation gages, liquid-level gages, time-domain reflectometry and fiber-optic gages.

13A.3.1 Transverse Deformation Gages

Transverse deformation gages are installed in boreholes or pipes for measuring deformations transverse to their length (Dunnicliff, 1993). Typical applications include locating the depth of a slide plane and measuring deformations within and below embankments. Types of transverse deformation gages include shear plane indicators, plumb lines, inverted pendulums, in-place inclinometers and deflectometers. Of these devices, only in-place inclinometers have potential application at coal refuse disposal facilities.

In-place inclinometers are usually designed to operate in a vertical or near-vertical borehole and to provide nearly the same information as a standard probe inclinometer. The device consists of a series of gravity-sensors connected by articulated rods. The sensors can be either uniaxial for measuring displacements in one plane or biaxial for measuring displacements in two planes. The sensors are positioned at intervals along the borehole and can be oriented to capture displacements at critical locations. In-place inclinometers are typically installed in the same casings used for conventional inclinometers, thus permitting the devices to be removed for recalibration (possibly interrupting data continuity) or reused elsewhere. Compared to conventional inclinometers, in-place devices offer advantages such as more rapid reading, improved precision, automatic data acquisition, and alarm triggers. Their comparative disadvantages include greater complexity and expense and inability to remove the effect of any long-term drift of the gravity-sensing transducer by reversing the orientation of the sensor as can be done for conventional inclinometers.

13A.3.2 Liquid-Level Gages

Liquid-level gages are instruments that use a liquid-filled tube or pipe for determination of relative vertical deformation. Relative elevation is determined with a manometer or pressure transducer. Liquid-level gages are used primarily to measure the settlement of foundations or embankment fills. Because the devices are buried below the structure or embankment fill, there are no interferences of the type that occur with fixed embankment extensometers (Section 13.2.1.2.5.). Liquid-level gages can only measure relative movements between the measurement location and the reading station. If the exact settlement or heave at a specific point is required, the reading station elevation must be surveyed and referenced to a benchmark datum each time measurements are taken.

These devices are usually sensitive to changes in liquid density due to temperature effects, surface tension effects, and loss of continuity of the liquid in the tube. The greatest potential source of error is discontinuity of the liquid due to gas bubbles in the fluid. Single-point, multi-point and full-profile liquid-level gages are available. Single-point gage types include:

- Both ends at same elevation
- Readout unit higher than the measurement cell
- Readout unit lower than the measurement cell

The most common single-point gage types have the readout unit higher than the measurement cell with pressure readings accomplished using a transducer located either in the measurement cell or in the readout unit. Both of these gage types suffer from the limitation that only a single

point is monitored, but the unit with the transducer in the readout is generally preferred because the transducer is accessible for calibration during the monitoring period, and the system has fewer limitations and requires less diligent oversight during installation and monitoring. Additional details related to gage types, advantages and limitations, and approximate precision of liquid-level gages are provided in Dunnicliff (1993).

Various multi-point gages have been developed, but users tend to prefer installing several single-point gages because loss of a single multi-point gage can result in the loss of the entire system (Dunnicliff, 1993). Full-profile gages consist of a near-horizontal plastic pipe and an instrument that can be pulled along the pipe. Readings are made incrementally along the length of the pipe so a full lateral profile is obtained. However, the devices have numerous limitations (e.g., temperature errors, lack of exact knowledge of the horizontal position in the pipe) that make a full-profile device such as a horizontal inclinometer ([Section 13.2.1.2.7](#)) a preferred choice.

13A.3.3 Time-Domain Reflectometry

Time-domain reflectometry (TDR) is radar along a coaxial cable. TDR involves measurement of the time it takes for an energy pulse to travel down a cable, encounter a known or unknown distortion in the cable, and reflect a signal back to a reading instrument. The time is converted to distance and the data are displayed as a waveform and/or distance reading. The ability to interpret TDR reflections anywhere along the cable allows activity to be monitored over large volumes or areas such that TDR monitoring can replace many single-point measurement instruments. The technique has been used for a variety of deformation measurements related to landslide and slope monitoring, ground subsidence due to mining, sinkholes, groundwater extraction, and scour of bridge foundations.

The use of TDR can complement inclinometer technology. TDR cable surveillance can detect very thin or localized shear zones. Use of TDR in combination with inclinometers or tiltmeters allows remote operation as well as sensing of both gradual tilt and localized deformation. O'Connor and Dowding (1999), Dowding (2002) and Dowding and O'Connor (2000) describe some of these applications.

[Figure 13A.3](#) shows a TDR cable grouted into a borehole. The cement-bentonite grout backfill in the borehole must be designed to fracture easily, so that the cable is deformed as movement occurs within the surrounding medium. Appropriate grout strengths vary considerably, but grouts for boreholes in soil and rock are typically tremmied into place using grout pumps on drill rigs. In general, the unconfined compressive strength of the grout should be less than the strength of the material where the shear failure can occur. Blackburn and Dowding (2004) provide details regarding grout selection and design. Dowding (2002) reports that braided coaxial cable is sometimes strapped to the outside of inclinometer casing in larger holes to save money and drilling costs. Unfortunately this cost-saving method has not performed well, probably because of the low sensitivity of the braided cable and spreading out of the localized shear zone caused by the casing.

13A.3.4 Fiber-Optic Gages

Fiber-optic sensors make use of the ability of optical fibers to convey light from a source to a photosensitive detector (Dunnicliff, 1993). The sensors can be used to indicate the relative position between an object and the end of the fiber or the distance between two points along the fiber. The sensors can also monitor bending. Advantages of fiber-optic sensors include small size, reliability, insensitivity to temperature and humidity changes, immunity to electrical noise (e.g., lightning) low signal loss, and the ability to transmit light along curved paths.

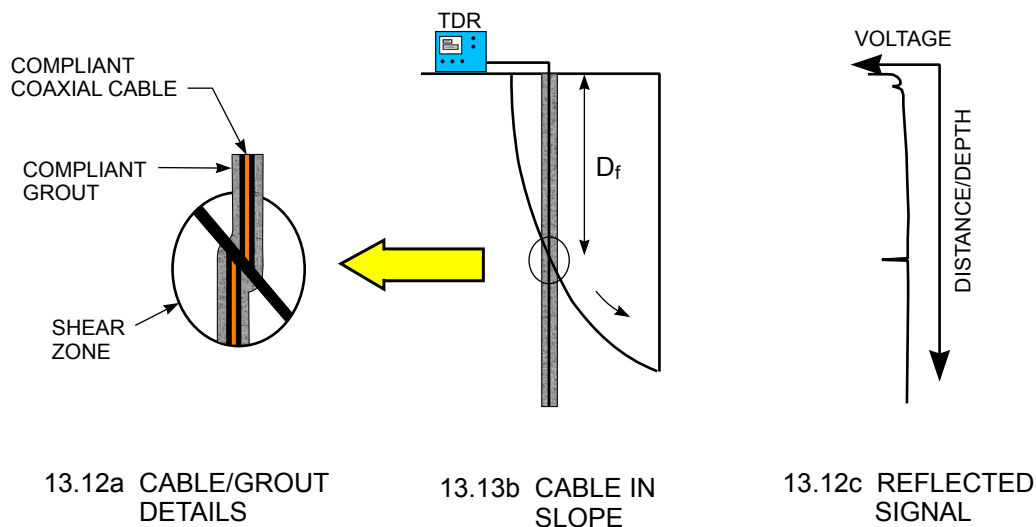

(DOWDING, 2002)

FIGURE 13A.3 TIME-DOMAIN REFLECTOMETRY OPERATION

A fiber-optic sensor consists of two facing mirrors that are made of a semi-reflective coating deposited on the tips of optical fibers. The gap between the mirrors (i.e., Fabry-Perot cavity length) varies from almost zero to a few tens of microns when the gage is unloaded. The separating distance is the gage length and represents the actual measuring base of the strain gage. The gage functions by reflection and cross interference of light emitted along the fiber-optic cable at the mirrors. The return optical signal is processed using a Fizeau interferometer and a linear charge-coupled device to determine changes in separation between the mirrors. If the gage is bonded to a substrate (e.g., a metal sensing element), strain variation in the axial direction will produce a variation of the cavity length, and strain is then equal to the ratio of the change in cavity length to the gage length. Both displacement and strain gage sensors are available (Choquet et al., 2000), but most reported applications for these devices have been for monitoring structural components.

13A.4 AUTOMATED DATA ACQUISITION

Although not yet commonly used to monitor performance at coal refuse disposal facilities, automated data acquisition systems have been demonstrated to be reliable and cost effective for monitoring the performance of constructed works and their surrounding environment, especially at sites where access is difficult or where regular survey and/or monitoring control are not practical or economical. With time, automated data acquisition systems will continue to improve with the likelihood that their use at coal refuse disposal facilities becomes more common.

Most automated data acquisition systems:

- Are programmed to retrieve data on a prescribed schedule without human intervention.
- Are designed to accommodate more than one transducer.
- Incorporate signal conditioning to amplify the output and present it in terms of engineering dimensions.
- Record data or transmit it elsewhere for recording.

Figure 13A.4 presents a generalized block diagram for an automated data acquisition system. As described by Dunnicliff (1993), the power supply and signal conditioning convert the output of analog transducers into a signal that is measured and converted to numeric values by an analog-to-digital converter. In most systems the signals from the transducers are conditioned to produce a DC voltage or binary decimal signal. The electronics controlling the systems perform various functions such as: (1) controlling measurement frequency, (2) scaling and displaying the data, (3) converting output to engineering units, (4) averaging data, (5) checking for alarm limits, and (6) controlling external equipment such as alarms. The controlling electronics have some memory capacity, but generally data must be electronically stored for further analysis. Use of automated data acquisition systems is relatively simple for transducers that produce a full-scale DC output voltage of 1 volt or more because these devices require minimal interfacing and signal conditioning. LVDTs, DCDTs, potentiometers, force-balance accelerometers, and high-output electrical resistance strain gage networks are included in this category. Thermocouples, thermistors, and resistance temperature devices used for temperature measurements require minor interfacing for use with automated data collection systems.

Other transducers such as low-output electrical strain gages and vibrating-wire, magnetostrictive and induction-coil transducers require special signal conditioning. This signal conditioning is usually provided by a plug-in module to the automatic data acquisition system. For these types of transducers, a dedicated data logger provided by the transducer manufacturer is usually the best choice (Dunnicliff, 1993).

Non-electrical sensors such as pneumatic transducers; plumb lines and double-fluid, full-profile settlement gages; and twin-tube hydraulic piezometers can be monitored using an automatic data acquisition system and methods described in Dunnicliff (1993). Electrical transducers that function by being manually passed through a pipe (e.g., magnetic reed switches and induction-coil transducers used with probe extensometers) are not appropriate for use with automatic data acquisition systems.

A complete data acquisition system consists of data logger, data communications/retrieval system, and software components. The data logger should have proven reliability for geotechnical applications and be compatible with a wide range of sensors and data retrieval options. A single data logger can read a large number of sensors provided that they are confined to a relatively small area. Additional data loggers should be used if instruments are deployed over a wide area. This approach keeps signal cables short, reduces problems with signal noise, and minimizes the potential for damage from construction activities and electrical transients. The cost savings realized by reducing cable runs can sometimes pay for the additional data loggers.

Multiplexers increase the number of sensors that can be monitored by a data logger. Data loggers can control several multiplexers, each of which are capable of handling 32 two-wire sensors or 16 four-wire sensors of the same type. In practice however, a data logger usually controls only one or two multiplexers, and additional data loggers and multiplexers are employed if there are more instruments. Certain types of sensors require additional interfaces. For example, vibrating wire sensors require a vibrating-wire interface to be connected between the data logger and a multiplexer. Power to operate data loggers, multiplexers and instruments is generally from a battery that is charged by an AC power line or a solar panel. Where feasible, the system should be hard wired or potential power problems, such as maintaining battery charges during cold weather, should be investigated. All data loggers, multiplexers and related equipment should be housed in weatherproof enclosures.

Data retrieval options include wired and wireless links. Wired links for data retrieval include direct connection to a personal computer, telephone modems, short-haul modems, and multi-

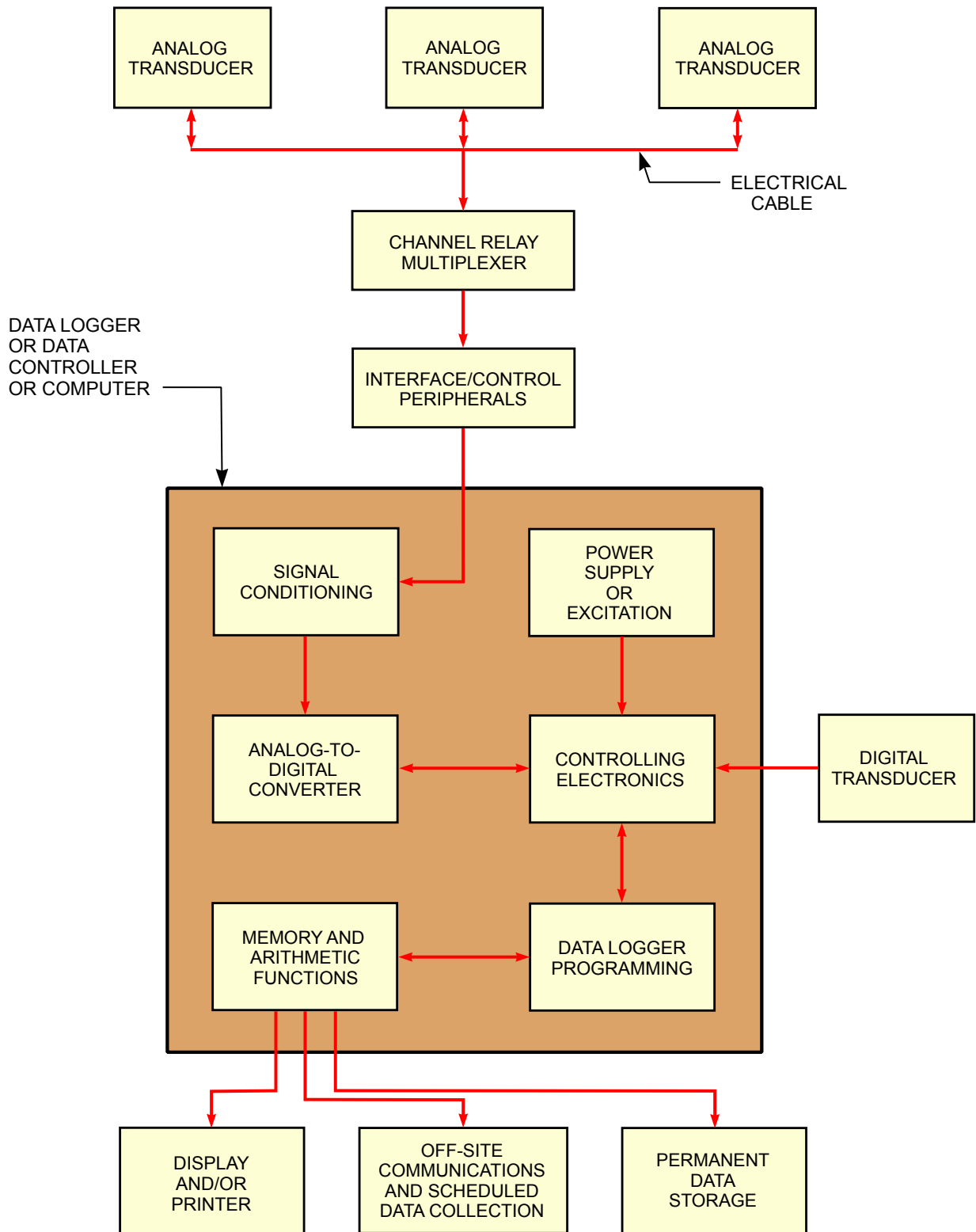

(ADAPTED FROM DUNNICLIFF, 1993)

FIGURE 13A.4 GENERALIZED BLOCK DIAGRAM FOR AUTOMATIC DATA ACQUISITION SYSTEM

drop networks. Wired links are usually less expensive, easier to set up, and better for real-time data retrieval than wireless links. Wireless links for data retrieval include cell modems, spread-spectrum radio modems, licensed-frequency radio modems and satellite modems. Wireless links are useful when distances or obstacles make wired links impractical. Also, to the degree that wireless links eliminate surface runs of cable, they also reduce problems caused by electrical transients. However, before an investment is made in wireless links, a check should be made for the presence of high-voltage power lines or radio transmission towers that could make the site too noisy for a wireless link. Additional details regarding data retrieval options are described by van der Veen (2002).

Data logger control software provides a fast, reliable and cost-effective means to collect, process and distribute data from the data logger to a local or remote personal computer. The control software is typically customized for each application to facilitate automatic processing of readings, alarm checks, graphic displays, and report generation. The logger control software can operate on a web server so that access is available from the Internet, a company intranet, or a stand-alone personal computer. Users can access the web through web browsers and click on links to access data and graphic presentations. Access controls can be established for identification of individuals that have rights to set up projects, graphs, reports, and alarms. Data that are not logged automatically can be entered manually using a web browser. The software can scan incoming readings for alarm conditions and then store the readings in a project database.

Automatic data acquisition and transmission systems can make instrumentation programs more susceptible to lightning damage and ground fault problems, as the number and density of cables and electrical components increases on a site. Instrumentation manufacturers can provide guidance on protecting these systems, which may include (Shoup, 1992): (1) diversion systems consisting of multiple lightning arresters (lightning rods, grounded to depths below the sensors) positioned outside the area being instrumented, (2) protective ground systems consisting of non-insulated copper ground conductor paralleling cables from the proximity of the sensor to the terminal box (separated from the cables by approximately 6 inches and extending to a depth of 5 feet below the sensor), and (3) primary lightning protection devices such as gas discharge tubes to protect cable connections to data acquisition modules (provided an appropriate protective ground system is installed). Other measures may be appropriate for surface data acquisition systems and equipment, although replacement of these components is less of a concern.

13A.5 INSTRUMENT AND SYSTEM RELIABILITY

The most important criterion for performance monitoring is reliability (Dunnicliff, 1993). Reliability is a function of instrument and system features and project personnel. Instrumentation system features that are associated with reliable performance include:

- Simplicity
- Self verification
- Durability in the installed environment

Simplicity of transducers should be a primary objective when instruments for a particular application are planned and selected.

Self verification means that instruments can be verified (i.e., calibrated) in place. Examples given by Dunnicliff (1993) include:

- Checking a fixed borehole extensometer with electrical transducers by inserting a dial gage at the head.

- Changing the head in a standpipe piezometer by raising or lowering the water level and verifying that the hydraulic response is consistent with the hydraulic conductivity of the surrounding ground.
- Using duplicate transducers of the same or different type to confirm local readings.
- Confirming that check sums from inclinometer readings are reasonably constant for all depth intervals.

Durability in the installed environment refers to the longevity of sensors, the connections between sensors and the data acquisition system, and the operation of the data acquisition system within the project setting. Factors such as pressure and temperature changes; duration of operation; chemical, biological and moisture environmental factors; and electrical grounding affect instrumentation system durability.

Sometimes it is not possible to achieve simplicity, self verification and durability in the installed environment, but these should be objectives in planning instrumentation systems, particularly for long-term applications. Equally and perhaps more important to the success of an instrumentation program are the people involved. The success of system planning, initial calibration and inspections, equipment installation, maintenance and recalibration, and data collection, processing and interpretation is directly related to the care and motivation of the people responsible for these activities.

The in-service functionality and reliability of an instrumentation system can be assessed by implementing an instrumentation maintenance program. The features of such a program include regular maintenance and recalibration, as described in [Section 13.3](#).

Chapter 14

EMERGENCY ACTION PLANNING

14.1 PURPOSE

Emergency action planning for dams includes establishing procedures and identifying potential actions and resources for responding to a condition of impending or actual dam failure. Guidelines published by the Federal Emergency Management Agency (FEMA; 2004a, 2004b) provide general information on hazard-potential classification and emergency action planning for dams. The guidance presented in this chapter is divided into two parts: (1) Emergency Action Plan (EAP) preparation and (2) emergency remedial actions that a facility Owner/Operator can take independent of responsibilities defined in the EAP to prevent an embankment/impoundment failure or to reduce potential damage in the event that a failure does occur.

EAP preparation is addressed in Section 14.2. The intent is to provide an understanding of what an EAP is, when one should be prepared, and recommended practice for preparation. However, it should be understood that EAPs are generally submitted to state agencies for review and approval and must meet the requirements of the state (or states) in which the facility and potential inundation area are located. In addition to state guidance, FEMA (2004b) and the Natural Resources Conservation Service (NRCS, 2007b) have developed guidelines for EAP preparation, and some states may be using or may adopt these or similar guidelines. If a facility is not under state jurisdiction, then the aforementioned federal guidelines should be useful. The first step in EAP preparation for any site should be to determine what guidelines are applicable. While the guidelines presented herein are recommended practice, some of the information presented may not be applicable in all instances. Most states have a specific structure and format that should be followed.

EAP preparation is a prudent practice for significant- and high-hazard-potential dams and the Owner/Operator typically has specific responsibilities related to notification of authorities in the event of development of an emergency situation. However, there may be additional actions that can be taken by the Owner/Operator that will possibly prevent or minimize damage due to a failure. Potential actions for several emergency scenarios are discussed in [Section 14.3](#).

14.2 EMERGENCY ACTION PLAN PREPARATION

14.2.1 Background

Structures that impound large volumes of water or tailings slurries represent a potential danger to inhabitants of low-lying areas located downstream. Some notable dam failures that have occurred

in the U.S. and the resulting loss of life are presented in Table 14.1. It was the sudden failure of the Buffalo Creek Dam on February 26, 1972 during a period of heavy rainfall that elevated national awareness of the potential danger associated with coal refuse impoundments and led to a program of tailings dam and impoundment inspections and hazard classification, as well as MSHA's current coal refuse impoundment regulations.

TABLE 14.1 HISTORICAL U.S. DAM FAILURES

Year	Dam	Location	Deaths
1889	South Fork	Pennsylvania	2209
1972	Buffalo Creek	West Virginia	125
1972	Canyon Lake	South Dakota	139
1976	Teton	Idaho	11
1977	Toccoa Falls	Georgia	39

Today most states regulate non-federal dams within their boundaries. This regulation normally entails: (1) classification as to hazard potential level, (2) design and construction requirements, and (3) periodic inspections. Impounding coal refuse embankments and dams are classified as to hazard potential in accordance with a system comparable to that adopted by FEMA, as discussed in Section 3.1. There may be some variation in the number of hazard level categories and the terminology from state to state, but all state classification systems are generally consistent with the FEMA system. It should be noted that the hazard potential level is strictly a function of the potential consequences of a dam failure and is not related to the construction of the dam, its condition, or its susceptibility to failure.

Dams or impounding embankments that have significant or high hazard potential in accordance with the FEMA (or state equivalent) hazard classification system should have an EAP in place. These are structures that, if they were to fail, would likely cause loss of life or significant property damage. An EAP is a document that establishes emergency procedures to be followed in the event of a catastrophic failure of the structure leading to rapid downstream flooding. While some significant and high hazard potential dams in the U.S. may not currently have EAPs in place, they are generally being required for coal refuse impoundments and dams by state dam safety regulatory agencies. FEMA (2004b) in the Federal Guidelines for Dam Safety: Emergency Action Planning for Dam Owners (FEMA 64) indicates that each high and significant hazard dam should have an EAP; MSHA has encouraged mine operators to prepare EAPs consistent with FEMA 64.

It should also be noted that 30 CFR § 50 requires mine operators to immediately notify MSHA of accidents. Conditions that constitute an accident are defined under 30 CFR § 50.2. One of the definitions of accident indicated in 30 CFR § 50.2(h) (10) is, "An unstable condition at an impoundment, refuse pile, or culm bank which requires emergency action in order to prevent failure, or which causes individuals to evacuate an area, or failure of an impoundment, refuse pile, or culm bank."

While not equivalent to the requirements for an EAP, MSHA's regulations under 30 CFR § 77.216-3 do require inspections of coal company dams at specified intervals for hazardous conditions and that actions be taken when a potentially hazardous condition develops, including: (1) notification of the MSHA District Manager, (2) notification and preparation for evacuation, if necessary, of coal miners who may be affected from coal mine property, and (3) examination of the structure by a qualified

person at least every 8 hours. These regulations should be reviewed as part of the preparation of an EAP, particularly as related to identification of hazardous conditions and mine personnel responsible for notification. Since a dam failure can impact persons living well away from mine property, an EAP must take into account the entire downstream area that will potentially be affected.

A possible mode of failure for an impounding coal refuse embankment is breakthrough of the impoundment into underground mine workings unrelated to dam failure. This can result in flooding of the mine workings and release of flood flows at a mine opening relatively far from the impounding embankment. EAPs for postulated dam failures involve a postulated dam breach and downstream release. FEMA and state regulations and guidelines are tailored to this type of event. However, if a breakthrough is plausible, an evaluation of such a release and the potential consequences should be made. Such a study may involve many conservative assumptions related to the size and timing of the breakthrough and analyses of flow through the breakthrough to determine the location and extent of possible flooding. The result should be an inundation map for the area that would be affected by flooding. All other aspects of EAP preparation would remain essentially the same.

14.2.2 Federal Guidelines for Dam Safety

The Interagency Committee on Dam Safety (ICODS) was established in the late 1970s to address dam safety issues. ICODS is chaired by FEMA and comprises the federal departments and agencies (including MSHA) that have responsibility for dams and dam safety.

EAP guidelines and a suggested format for use by the ICODS agencies are provided in FEMA (2004b) cited above. Some states have adopted the ICODS guidelines for EAP preparation, while others have developed their own guidelines and plan formats. In any case, the FEMA publication is recommended reading for anyone that is preparing an EAP. Also the NRCS (2007b) has developed a sample EAP and an electronic “fillable form” template” for preparation of EAPs. This template and related documents are available on the NRCS web site.

In the discussion that follows, EAP preparation and content are discussed in general terms and no specific format guidelines are presented. The appropriate state regulatory agency for each dam should be contacted to determine specific EAP format, submittal procedures, and approval requirements.

14.2.3 Basic Elements of an EAP

The following list of basic EAP elements is an expansion and refinement of a list originally developed by FEMA (2004b) and reflects some typical state requirements:

- Physical description of dam – A physical description and accurate location of the dam and related hydraulic structures with a map should be provided.
- Potentially inundated area – The maximum extent and arrival times for inundation resulting from postulated dam breaches should be clearly indicated on a map that shows the mining facilities, dam, downstream channel, important highways and streets, homes, businesses and any other critical facilities (e.g., hospitals, nursing homes, day-care centers) that could be affected by a dam failure. Locations of reception centers and treatment facilities designated in the EAP and locations of road blocks/traffic control points and evacuation routes should also be shown on the inundation map.
- Implementation triggers and emergency responses – Conditions that initiate implementation of emergency response procedures should be clearly indicated in the EAP (e.g., reservoir elevations, spillway flow depths, or visible conditions of distress). Emergency response activities associated with the implementation triggers should be delineated. The NRCS Fillable Form Template (NRCS, 2007b) provides useful information on trigger conditions.

- Notification requirements – The responsibilities for notification should be clearly delineated. The notification hierarchy is frequently presented in a flowchart format, but other formats may be used consistent with state requirements. The important factor is that each plan participant has a clear understanding of his or her notification responsibilities.
- Participant responsibilities – Responsibilities of each plan participant should be clearly indicated in the EAP. Typical key responsibilities include the owner’s responsibility to notify appropriate agencies when there is a threat of dam failure, responsibility of local emergency management officials for warning and evacuating affected persons, requirements for police/fire departments for installing road blocks and/or managing traffic at specific locations, EMS/ambulance services responsibilities for transporting the injured, and the responsibilities of emergency service providers relative to operation of reception and treatment centers.
- EAP public notices and copies – Notices indicating the location of publicly available EAP copies may be required to be posted in public places such as municipal buildings, fire departments (social halls), tax offices, and other locations accessible to the public.
- Exercises/training – Some states require that EAPs have provisions for exercises and/or training while others do not. Exercises and training sessions are an effective way to provide EAP participants with a clearer understanding of their responsibilities and required actions.
- Plan maintenance – EAPs are normally required to be updated on a regular basis – typically one to five years. All elements of an EAP should be periodically reviewed and updated as needed to reflect changes in regulatory requirements, mine facilities, the dam and related structures, inundation area, street and highway infrastructure, plan participants and telephone numbers, and other key information. Some states require periodic evaluation of downstream development to determine whether changes have occurred that could affect the dam’s hazard classification and EAP contents. Optimally, the names of key plan participants and contact information should be updated annually or as changes occur.
- EAP Appendices – Supporting documents should be provided in appendices to the EAP. The contents of the EAP appendices will vary depending on state requirements.

The submittal and approval process for an EAP will vary from state to state, but a typical scenario might involve submittal of a draft to the county EMA for review and approval followed by review by state environmental and emergency management agencies. During this period, plan participants are also made aware of the EAP preparation and have the opportunity to provide input. Comments based on the reviews are addressed and the final version, once final approval is obtained from the state, is distributed to the plan participants.

14.2.4 Dam Inspection and Inundation Area Reconnaissance

The first step in the preparation of an EAP normally involves a field inspection of the dam or impounding embankment and a reconnaissance of the downstream area that would potentially be flooded as the result of a catastrophic failure.

14.2.4.1 Dam Inspection

A dam inspection should be performed in sufficient detail to allow a reasonable determination of critical sections and parameters for dam breach modeling. If the inspection is being performed to satisfy

state annual (or other inspection frequency) requirements, then it should be detailed enough that the applicable state inspection forms can be fully completed. In addition to the dam, reservoir areas that could be overtopped or subject to instability should also be evaluated. The purpose of the inspection is not only to identify areas of concern, but also to evaluate features or conditions that may warrant special consideration in the dam breach analysis (e.g., overtopping threat at a saddleback ridge forming the impoundment or potentially rapid failure associated with a seepage area).

14.2.4.2 Downstream Channel Reconnaissance

Prior to the performance of a dam breach analysis, the channel downstream from the dam should be explored and features that might affect flow conditions following a dam breach should be accurately documented. For example, channel constrictions or other conditions that could cause a backwater effect should be noted. Cross-section data should be obtained at such locations for incorporation into the dam breach analysis model (Section 9.9). Also, if adequate cross-section data cannot be obtained from topographic maps, field surveys of cross sections should be performed. Floodplain conditions such as heavy brush or the presence of flow retarding structures (e.g., natural valley contractions, bridges, railroad and highway fills) should be noted and should be appropriately reflected in the dam breach model channel roughness parameters.

The downstream channel reconnaissance should also include notation of critical facilities that would likely be affected by flooding both on and off the mine property. At the mine property, areas that are staffed or are critical access points for personnel (e.g., mine structures, shafts, pits, utility stations, etc.) should be noted. Additionally, public structures such as hospitals, schools, day-care centers, nursing homes, utility plants and substations, emergency service provider bases, and industrial firms with large numbers of employees should be noted. Other conditions such as street locations and intersections not shown or incorrectly indicated on available maps should be noted so that the inundation map reflects current conditions.

14.2.4.3 Physical Description

A description of the impounding structure and its construction, related hydraulic structures, and other information such as observations relative to the potential inundation area, should be provided in the EAP. This description should be based upon data from the dam inspection and downstream channel reconnaissance, as appropriate.

14.2.5 Inundation Map Preparation

14.2.5.1 Causes of Dam Failures

There are many possible causes for dam failure and/or sudden impoundment release. Possibilities include:

- Overtopping of the dam caused by reservoir inflows that exceed the total combined storage and spillway capacity.
- Piping and internal erosion of the foundation or embankment materials.
- Structural failure of the dam embankment resulting from an earthquake.
- Movement and/or failure of the foundation supporting the dam.
- Failure of an upstream dam or major landslide into the reservoir.
- Inadequate maintenance leading to loss of spillway capacity or structural weakness.
- Breakthrough of an impoundment into mine workings and subsequent release downstream.

The first two items in the list account for most actual dam failures.

14.2.5.2 Dam Breach Analysis

Consistent with the above, there are two modes of dam breach that are most commonly analyzed for determination of downstream inundation due to dam failure. These are: (1) overtopping of the dam due to inadequate spillway capacity during the inflow design flood (IDF) and (2) dam failure under normal conditions (i.e., normal pool in the reservoir and normal inflow to the reservoir). The latter condition is sometimes referred to as a “sunny day” failure. Breach development and determination of the outflow and resulting inundation from a breached dam or embankment are discussed in [Section 9.9](#).

14.2.5.3 Inundation Map

The inundation map facilitates notification and evacuation of persons in the flooded area through graphical presentation of the flood limits. The inundation limit for emergency planning purposes is the maximum extent of flooding based upon the most critical dam failure scenario. For the IDF condition, the downstream limit of inundation mapping is typically determined as the point at which the flow level returns to within a specified vertical distance of the flow without dam breach (e.g., one or two feet). For a “sunny day” failure, the downstream limit of inundation mapping should be the point at which flow is wholly contained within the stream channel banks.

The limits of inundation should be plotted on a topographic map that clearly indicates the locations of streets and other roadways and any critical facilities that would be flooded. Use of semi-transparent shading to show the extent of inundation is recommended. Typically, inundation maps are developed from U.S. Geological Survey (USGS) topographic maps. The scale of an inundation map typically varies depending upon the density of streets and associated structures. Urban areas normally require considerably more map detail than less populated areas.

The inundation map should also clearly show locations where roadblocks/traffic control will be needed. Responsibilities for operation of these roadblocks/traffic control points may be delineated in a separate table, depending upon state requirements. The inundation map should indicate the location of any reception centers and/or treatment facilities identified in the EAP. Evacuation routes (delineated by arrows indicating the direction of evacuation) should be clearly marked on the inundation map. It is also recommended that the arrival times (in relation to the time of breach) for the leading edge and peak discharge associated with the flood wave be shown on the inundation map. If this information cannot be presented on the inundation map, it may be provided in a separate table. A portion of a typical inundation map is shown in [Figure 14.1](#).

14.2.6 Participant Responsibilities

An EAP must clearly define the responsibilities of all parties that would be involved in a dam failure scenario. These parties include the dam owner (or designated representative); state, county and local emergency management officials; emergency service providers (police, fire, EMS, Red Cross); elected officials; radio and television stations; school systems; state transportation agencies; public transit authorities; railroads; and parties such as nursing home operators and large businesses that would be inundated.

The EAP should indicate that the dam owner or designated representative is responsible for monitoring the dam in any situation where catastrophic failure is a possibility. The owner or designated representative should be responsible for initiating the notification process (e.g., notifying applicable state agencies, the MSHA district manager, the County Emergency Management Agency (EMA), the County 911 center and the National Weather Service (NWS)). Further discussion of notification responsibilities is provided in [Section 14.2.8](#).

The responsibilities of each participant organization or individual should be clearly delineated. For example, a police department or sheriff’s office might set up a mobile communication station (squad

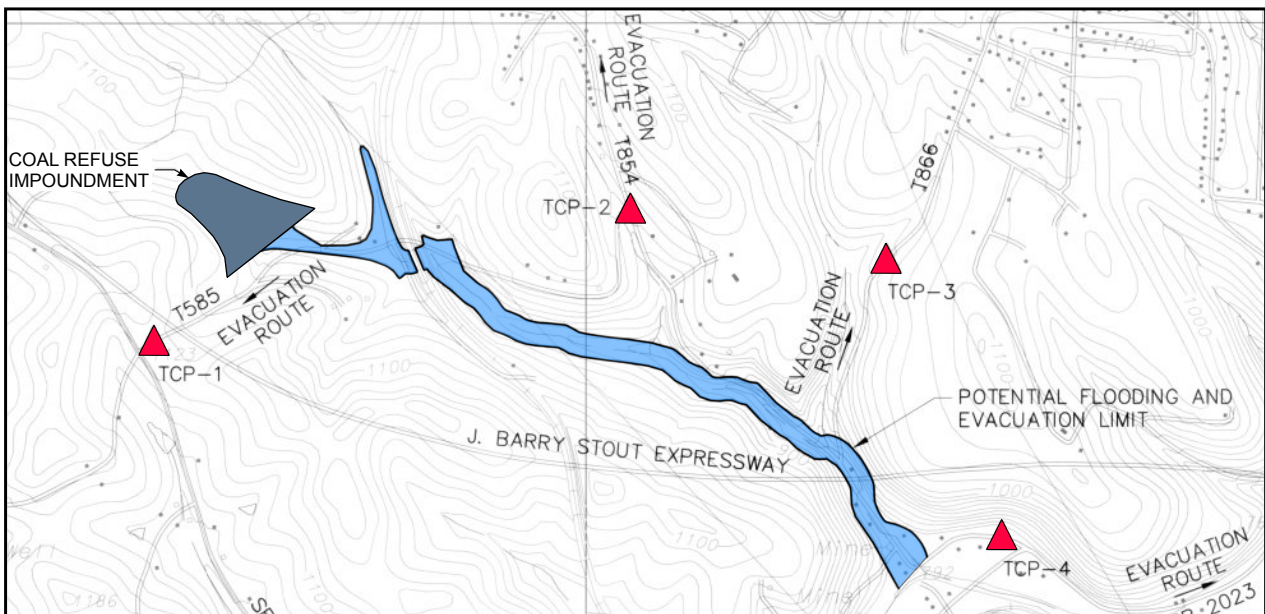

LEGEND

- INUNDATED AREA
- TRAFFIC CONTROL POINT

FIGURE 14.1 INUNDATION MAP FOR COAL REFUSE IMPOUNDMENT

car) at the dam, operate several traffic control points, and be responsible for evacuation. Local Emergency Management Coordinators (EMCs) are typically responsible for maintaining contact with the County EMA, notifying local elected officials and utility services, coordinating evacuation efforts, and developing damage assessments.

14.2.7 Implementation Triggers and Emergency Responses

As indicated in the previous section, the dam owner or designated representative is responsible for monitoring the dam in the event that certain conditions occur that could eventually lead to failure. The extent of the monitoring may vary from part-time to continuous depending upon the severity of the dam breach threat. The EAP should clearly indicate what event or events are associated with a specific monitoring level and what conditions will trigger implementation of plan emergency responses. Triggers for monitoring are frequently tied to the occurrence of large amounts of rainfall in a short period of time. Continuous monitoring should be implemented in the event of a condition such as observed piping, significant slope movement, or the failure of a structural component of the dam.

Once monitoring has been initiated, triggers that implement emergency actions will typically be in the form of a specified water surface elevation below the embankment crest, a specified flow depth in the emergency spillway or other easily measurable parameter. However, any observation of a condition that could lead to dam failure or other sudden release of water or slurry from the impoundment, such as a breakthrough into an underground mine, should also trigger the process. The dam owner or designated representative is responsible for assessing the situation and, if an emergency condition is identified, providing notification to implement the emergency procedures in the EAP. Others who might assist in the assessment of site conditions and the need for notification, such as state dam safety officials and MSHA, may or may not be available to provide input.

Table 14.2 presents guidance related to conditions that may be triggers for monitoring and for implementation of an EAP, as adapted from NRCS (2007b). Such conditions may include blockage of the

TABLE 14.2 GUIDANCE FOR EAP EVENTS AND SITUATIONS

Event	Situation	Monitoring or Trigger Level
Overtopping	• Impoundment level is rising and approaching specified depth below embankment crest (minimum freeboard elevation)	1
	• Impoundment water level above specified depth below embankment crest (e.g., 1 foot)	2
	• Water is flowing over the dam	3
	• Water is flowing over an abutment or saddleback rim of impoundment	3
Spillway Erosion or Blockage	• Water starting to flow through emergency spillway	1
	• Emergency spillway flowing with bottom erosion advancing toward control section	2
	• Emergency spillway blocked by significant debris or landslide material with impoundment level approaching minimum freeboard elevation	2
	• Emergency spillway flowing with erosion at control section	3
Seepage	• New seepage areas or increased discharge from internal drain outlet within or near dam	1
	• New seepage areas or internal drain discharge with cloudy flow and increasing flow rate	2
	• Seepage at greater than a specified flow rate or causing erosion of the dam or foundation	3
Mine Discharge	• New mine discharge in the immediate vicinity of impoundment	1
	• New mine discharge in the immediate vicinity of impoundment with cloudy flow and increasing flow rate	2
	• Mine discharge at greater than specified flow rate	3
Sinkholes	• Observation of new sinkhole in impoundment area or on embankment	2
	• Rapidly enlarging sinkhole	3
Embankment and Abutment Cracking	• New cracks in the embankment or abutments at greater than specified width	1
	• New cracks in the embankment with associated seepage	2
	• New cracks in the abutment with seepage and increasing flow rate	2
Embankment Movement	• Observed movement/slippage of embankment toe, slope, or crest	1
	• Sudden or rapidly proceeding slides at embankment slope	3
	• Sudden or rapidly proceeding subsidence at embankment crest	3
Instruments	• Instrument readings beyond specified values	1
Flood	• Rainfall or snowmelt predicted to be above specified level	1
Earthquake	• Measurable earthquake felt or recorded within specified distance of dam	1

Monitoring or Trigger Levels: 1. Non-emergency, unusual event – slowly developing
 2. Potential dam failure situation – rapidly developing
 3. Urgent situation, dam failure appears to be imminent or is in progress

(ADAPTED FROM NRCS, 2007b)

principal or emergency spillway, significant sloughing or slope failure in the dam embankment, overtopping or severe erosion, structural failure of a dam component, occurrence of sinkholes, cracking in the embankment, or other event that could lead to catastrophic failure. At sites where underground mine workings are present, elevated mine pool levels or mine discharges may also be triggers.

NRCS (2007b) recommends establishing emergency levels for identifying monitoring and response actions ranging from an initial level associated with a slowly developing, unusual (non-emergency) event to an advanced level associated with potential imminent failure or a failure in progress. While establishment of such levels may be useful to dam owners and operators in responding to dam emergencies, some states do not currently require that this be done.

It is recommended that emergency responses be identified for each implementation trigger. In addition to notification requirements, as subsequently discussed, other actions ranging from continued monitoring to preventative measures may be appropriate. It may also be useful to identify in the EAP additional personnel, sources of construction materials, and contractors that can be utilized in an emergency situation. This information may also be provided in the Operation and Maintenance Plan.

14.2.8 Notification Requirements

Notification of plan participants should be carried out in a systematic manner such that the most critical notifications are made immediately following a triggering event. Each plan participant must know his or her responsibilities for contacting other participants, including the preferred order of contact. The contact information should allow for communication on a 24-hour-per-day, seven-day-per-week basis. Contact information should be kept up to date as personnel or telephone numbers change. FEMA recommends that a flowchart be prepared that illustrates the notification process and each individual's notification responsibilities. FEMA's suggested format places the notification flowchart at the very front of the EAP. Some states have adopted the FEMA-recommended format (referred to as the ICODS format), while other states do not employ an actual flowchart, but instead use a structured text format to convey the same information.

Regardless of the location of a dam and the applicable state regulations, the important factor is that each participant's contact responsibilities, including the preferred order of contact, are clearly indicated in some manner. Typically the dam Owner or Owner's representative is responsible for contacting applicable state agencies, the County EMA/911 Center, MSHA and possibly the NWS. The County EMA/911 Center typically is responsible for contacting local EMCs, police and fire departments, EMS and ambulance services, local media, and other institutions, as appropriate. The EAP notification chart should be posted in prominent locations at the mine site for ready access during an emergency.

14.2.9 EAP Public Copies

It may be a requirement that copies of an EAP be made available to the public at locations such as state and local emergency management agency offices, public libraries, the dam owner's office or other locations with public access. These locations may be part of the specified content for the EAP. Also, local emergency response organizations are a good source of information. It is important that all versions of the EAP regardless of location or media be updated at regular intervals, as required by the appropriate regulatory agency.

14.2.10 Exercises/Training

States may or may not require that EAP exercises be performed on a regular basis or that participant training be performed. FEMA (2004b) defines five levels of exercise that may be employed to maintain an enhanced state of readiness for an actual emergency. The five exercise levels are:

1. Orientation seminar – This lowest exercise level involves bringing together the primary entities with a role or interest in the EAP (typically the dam owner and state and local emergency management agencies) to discuss the EAP. The primary purpose of an orientation seminar is for the participants to become familiar with the EAP and their roles/responsibilities. The orientation seminar may be used for planning a higher level exercise. Mine operators are encouraged to hold face-to-face meetings with local emergency management personnel to develop a working relationship so that their first contact is not during an actual emergency.
2. Drill – A drill is the lowest exercise level that involves actual exercise components. A drill typically involves in-house training for EAP participants.
3. Tabletop exercise – A tabletop exercise is typically a meeting of the dam owner and state and local emergency management officials in a conference room environment. A tabletop exercise begins with a description of a simulated event followed by discussions among participants of the EAP response procedures. Tabletop exercises are normally conducted in an informal, relaxed environment.
4. Functional exercise – A functional exercise is the highest level exercise that does not involve full activation of key plan participants or actual evacuation of downstream inhabitants. A functional exercise is intended to allow an evaluation of the ability of the dam owner and emergency management officials to perform their EAP responsibilities. A secondary objective is to improve coordination among EAP participants.
5. Full-scale exercise – A full-scale exercise involves the most realistic simulation of an actual emergency event. A full-scale exercise is intended to evaluate the operational capability of all aspects of and participants in the EAP interactively in a stressful environment with actual mobilization of personnel and resources. The participants “play out” their roles in a dynamic environment that provides the highest degree of realism possible. A full-scale exercise may involve actual evacuation of residents that would be in the downstream inundation area.

Typical state requirements are equivalent to the tabletop exercise level or lower. Exercises at any level will enhance the ability of EAP participants to perform their emergency function in the event of a dam breach.

14.2.11 Plan Maintenance

An EAP should be updated at regular intervals. Ideally, the names of key plan participants and contact information should be updated annually or as changes occur. The interval for regular updating varies from state to state, generally ranging between one and five years. EAP updates should be prepared by or have appropriate input from an engineer familiar with the impoundment and EAP preparation and should reflect any changes to the state’s EAP content and format requirements since the previous submittal.

Any changes to the dam and related structures and any changes that will affect the inundation map should be identified. For mine facilities where impoundment capacity has increased as a result of disposal plan modifications and staged construction, dam breach analyses should be reviewed and updated and, if necessary, a new inundation map should be prepared. Also, if there are changes to design bases such as a state-mandated increase in the IDF, a new dam breach analysis should be performed and a new inundation map should be prepared.

The scope of work for an EAP update should include a reconnaissance of the inundation area to determine if any new facilities (e.g., mining operation, day care center, nursing home, large business) are located in the inundation area and will be significantly affected. Also new highways or streets and

changes to existing highways and streets should be noted and the appropriate changes made to the EAP. Plans for roadblocks and traffic control should be reviewed. Evacuation routes should also be reviewed to make certain that they are still appropriate.

Personnel or positions previously identified in an EAP may have changed and updates should be made as necessary. Agencies such as the Red Cross should be contacted to verify that reception and treatment center information is current. Any information provided in the EAP that is no longer applicable should be removed or an update provided.

14.2.12 EAP Appendices

Supporting documents should be provided in appendices to the EAP. Depending upon individual state requirements, these could include:

- Calculation brief for the dam breach analysis, determination of downstream inundation area, and flood wave arrival times.
- A map showing the location of the dam and highways and streets that must be traveled to reach the dam with accompanying written directions.
- An inundation map providing limits of the extent of flooding and key information such as roadblock locations, reception and treatment center locations, evacuation routes, and other important data such as flood wave travel times to critical areas.
- Tables indicating responsibility for roadblocks and/or traffic management points (e.g., state highway patrol station, local police department, local fire department) shown on the inundation map.
- Roster of participating agencies, personnel and phone numbers.
- Notification flowchart indicating each participant's responsibilities relative to contacting other participants in the EAP.
- Check-off sheets to document when persons/agencies/responders were notified relative to plan implementation.
- Announcements to be read on radio and television when the EAP is implemented.
- Public notices for posting indicating where copies of the EAP are available to the public for review.

14.3 PREPARATION FOR POTENTIAL EMERGENCY REMEDIAL ACTIONS

When an emergency situation develops at an impounding embankment/dam, implementation of appropriate remedial actions could possibly delay, moderate or even prevent the structure from failing. Potential emergency management actions and responsibilities should be delineated in the Operation and Maintenance Plan ([Section 11.1.4](#)) so that personnel qualified and responsible for implementing these remedial actions are better equipped to assess the situation and to implement appropriate responses. Emergency situations should be evaluated at the earliest indication of a possible problem by an engineer familiar with dam safety who can recommend an appropriate course of action.

A potential failure mode analysis (PFMA), as discussed in [Section 12.1.1](#), can help in the identification of equipment, materials and potential remedial actions needed for responding to an emergency. Potential sources of equipment and materials should be identified and documented in the Operation and Maintenance Plan. In some situations, aggregate stockpiles (excess materials for scheduled drain or filter construction) may be available on site and may be useful in an emergency. Also, sources of emergency power for lighting or equipment operation can be identified. Potential emergency remedial actions that may be appropriate for emergency situations and should potentially be included

in the Emergency Management section of the Operation and Maintenance Plan are discussed in the following subsections. The designer or other dam safety engineer should assess whether these emergency remedial actions are applicable to their site.

14.3.1 Potential Overtopping During a Storm

The following actions should be considered in the event of a severe storm where the water level in the impoundment is increasing and is approaching the crest of the embankment:

- Placing additional material along the crest to increase freeboard. This will have the effect of temporarily allowing more water to be stored and will allow more water to flow through the spillway.
- Providing erosion-resistant protection for the downstream slope by placing riprap, rockfill, or other material in erosion-prone areas.
- Terminating pumping of water or slurry into the impoundment until the emergency situation abates.
- Lowering the water level by pumping or siphoning water out of the impoundment.
- Creating additional spillway capacity by making a controlled cut or breach in a saddle area or in a low embankment section where the foundation materials are erosion resistant and adding supplemental erosion protection where needed. The potential for the cut area to rapidly erode and release the reservoir should be considered before taking this action.

14.3.2 Movement or Sliding of the Embankment

If there is movement or sliding of an impounding embankment, the following actions should be considered:

- Placing stakes or pins and recording and evaluating the amount of movement versus time. Movement of a slope will generally accelerate prior to complete failure. Other monitoring could include piezometers and seepage weirs (record and evaluate).
- Lowering the water level at a rate and to an elevation considered to be safer given the slide condition.
- Stabilizing the slide by buttressing the toe area with additional rockfill, mine waste, spoil, or soil. If the buttress material does not have characteristics that will allow it to act as a filter and drain, available sources of other materials to perform the function in combination with the buttress material, as appropriate, should be identified.
- Lowering the phreatic surface by placing impermeable material on the upstream slope.
- Restoring lost freeboard, if necessary, by placing sandbags or by filling in the top of the slide. Note that this action will further load the sliding mass if it is not offset by buttressing of the toe area.

14.3.3 Internal Erosion or Piping through the Dam, Foundation or Abutments

If seepage through a dam or its foundation or abutments is detected and is found to be increasing at a rate that could threaten the stability of the dam, the following actions should be considered:

- Moving the slurry discharge point so that fines are deposited in the reservoir near the area where the problem seepage is most likely originating. For example, there may be a whirlpool in the reservoir, or seepage may be visible at an abutment.

- Lowering the impoundment water level until the flow decreases to a non-erosive velocity or until it ceases. The water level should remain lowered until corrective action is taken.
- Plugging the reservoir side of the flow area with material (e.g., hay bales, bentonite, or other materials) if the entrance to the leak is in the reservoir basin.
- Placing a weighted filter over the exit area to hold the materials in place. Preferably, several feet of a protective sand filter should be placed. The sand layer can be weighted with additional material. If sand is not readily available, a geotextile could also be used for the filter layer.
- Isolating the area where the seepage is originating, if possible, by constructing a perimeter dike around the area.
- Monitoring seepage relative to quantity and suspended solids.

14.3.4 Excessive Seepage and a High Level of Saturation in the Embankment

If wet areas are detected on the downstream face of an embankment along with a high phreatic surface indicating a high level of saturation and reduced embankment stability, the following actions should be considered:

- Monitoring frequently for signs of slides, cracking or concentrated seepage. Recording and evaluating piezometer readings and seepage weir flow measurements.
- Relocating the slurry discharge line to the extent possible to develop a delta and push free water back away from the upstream slope of the embankment.
- Lowering the water level in the reservoir to a safer level.
- Operating at a reduced level until the situation is evaluated.
- Lowering the phreatic surface by placing impermeable material on the upstream slope.

14.3.5 Spillway Failure or Erosion that Could Cause a Dam Breach

If an impoundment spillway fails or its capacity is reduced, or if there is erosion progressing such that a dam breach could result, the following actions should be considered:

- Providing temporary protection at the point of erosion by placing sandbags, rip-rap materials, or plastic sheets anchored with sandbags.
- Lowering the water level to a safe elevation. If an outlet is not available, pumping, siphoning, or a controlled breach may be required.
- Continuing operation at a lowered water level to minimize spillway flow.

14.3.6 Excessive Settlement or Subsidence of the Embankment

If excessive settlements are observed in the embankment or actual subsidence is detected, the following actions should be considered:

- Lowering the impoundment water level until the situation can be evaluated by: (1) releasing it through the primary spillway or by pumping, (2) siphoning, or (3) a controlled breach.
- Temporarily restoring freeboard, if necessary, by placing additional material such as mine waste, spoil, sandbags, etc. along the crest.
- Watching for increased seepage and internal erosion due to cracks resulting from differential movements. If observed, the actions indicated above should be employed.

- Checking for indications of damage to the decant conduit resulting from differential movement.

14.3.7 Formation of a Sinkhole on the Crest or Face of the Dam

In the event of observation of a sinkhole at the embankment crest or on one of the faces of the dam, the following actions should be considered:

- Lowering the impoundment water level.
- Checking the area downstream of the sinkhole to identify where material is being carried out. The measures indicated in Section 14.3.3 above for stopping or reducing internal erosion should be considered.

14.3.8 Earthquake

Subsequent to the occurrence of an earthquake that could potentially have damaged site structures, the following actions should be considered for each impounding embankment:

- Conducting an overall visual inspection of the dam and monitoring instrumentation.
- If the embankment has any upstream construction, the seismic shaking may have caused high pore-water pressures in the loose fines. Embankment faces should be checked for signs of sliding, and the crest should be observed for indications of settlement.
- Evaluating instrumentation data. Piezometer readings should be taken and compared to normal readings. The situation should be monitored until elevated pore-water pressures have dissipated. The impoundment water level should be lowered, if necessary.
- If settlement has occurred, it should be determined if measures should be taken so that the design storm can still be accommodated.

References

(* – Available on Manual DVD)

- Adler, L. and M.C. Sun, 1968, *Ground Control in Bedded Formations*, Bulletin 28, Virginia Polytechnic Institute Research Division, Blacksburg, VA.
- Albuquerque, A.J.J., 1994, *Geoenvironmental Aspects of Coal Refuse-Fly Ash Blends*, M.S. Thesis, Virginia Polytechnic Institute and State University, Blacksburg, VA.
- * Almes, R.G. and A. Butail, 1976, "Coal Refuse: Its Behavior Related to the Design and Construction of Coal Refuse Disposal Facilities," *Proceedings of the Seventh Ohio Valley Soils Seminar on Shales and Mine Wastes*, Lexington, KY.
- American Association of State Highway and Transportation Officials (AASHTO), 2008, *Standard Specifications for Transportation Materials and Methods of Sampling and Testing, Part I – Specifications*, 28th Ed., and *Provisional Standards*, 2008 Ed., AASHTO, Washington, DC.
- American Concrete Institute (ACI), 2008, *Building Code Requirements for Masonry Structures* (ACI 530-95), Farmington Hills, MI.
- American Concrete Institute (ACI), 2007, *ACI Manual of Concrete Practice*, Parts 1, 2, and 3, Farmington Hills, MI.
- American Concrete Institute (ACI), 2005a, *Guide to Mass Concrete*, ACI 207.1R-05, Farmington Hills, MI.
- American Concrete Institute (ACI), 2005b, *Building Code Requirements for Structural Concrete* (ACI 318-05) and *Commentary* (ACI 318R-05), Farmington Hills, MI.
- American Concrete Pipe Association (ACPA), 2007, *Concrete Pipe Design Manual*, ACPA, Irving, TX.
- American Concrete Pipe Association (ACPA), 1987, *Concrete Pipe Design Manual*, ACPA, Vienna, VA.
- American Water Works Association (AWWA), 2007, *Design of Prestressed Concrete Cylinder Pipe*, Standard C304-07, AWWA, Denver, CO.
- American Water Works Association (AWWA), 2004, *Steel Water Pipe*, M11, AWWA, Denver, CO.
- American Water Works Association (AWWA), 1995, *Concrete Pressure Pipe*, M9, 2nd Ed., AWWA, Denver, CO.
- * Andrews, D.E., J.L. Withiam, E.F. Perry and H.L. Crouse, 1980, *Environmental Effects of Slaking of Surface Mine Spoils – Eastern and Central United States*, Final Report, Contract No. J0285024, U.S. Department of the Interior, Bureau of Mines, Denver, CO.
- Appalachian Regional Commission, 1969, *Acid Mine Drainage in Appalachia*, Congressional House Document No. 91-180, Vols. I, II, and III, Washington, DC.
- Arkell, R.E. and F. Richards, 1986, "Short Duration Rainfall Relations for the Western United States," *Preprint Volume, Conference on Climate and Water Management*, American Meteorological Society, Boston, MA, pp. 136-141.
- * Arman, A., N. Samtani, R. Castelli and G. Munfakh, 1997, *Training Course in Geotechnical and Foundation Engineering: Subsurface Investigations – Participants Manual*, Contract No. FHWA-HI-97-021, Federal Highway Administration, National Highway Institute, Arlington, VA.

- ASTM International (ASTM), 2008a, *Annual Book of ASTM Standards, Section Five: Petroleum Products, Lubricants, and Fossil Fuels*, Volume 05.06, Gaseous Fuels; Coal and Coke, ASTM, West Conshohocken, PA.
- ASTM International (ASTM), 2008b, *Annual Book of ASTM Standards, Section Four: Construction*, Volume 04.08, Soil and Rock (I): D 420 – D 5611, ASTM, West Conshohocken, PA.
- ASTM International (ASTM), 2008c, *Annual Book of ASTM Standards, Section Four: Construction*, Volume 04.09, Soil and Rock (II): D 5877 – latest, ASTM, West Conshohocken, PA.
- ASTM International (ASTM), 2008d, *Annual Book of ASTM Standards, Section Four: Construction*, Volume 04.13, Geosynthetics, ASTM, West Conshohocken, PA.
- Atkinson, G.M. and D. M. Boore, 2006, "Earthquake Ground-Motion Prediction Equations for Eastern North America," *Bulletin of the Seismological Society of America*, Vol. 96, No. 6, pp. 2181-2205.
- Atkinson, G.M. and D.M. Boore, 1995, "Ground Motion Relations for Eastern North America," *Bulletin of the Seismological Society of America*, Vol. 85, No. 1, pp. 17-30.
- * Atkinson, G.M. and S.I. Kaka, 2006, *Relationships between Felt Intensity and Instrumental Ground Motion for New Madrid Shake Maps*, Report for Award 05HQGR0039, Department of Earth Sciences, Carleton University, Ottawa, QC, Canada.
- Atkinson, G.M. and W. Silva, 1997, "An Empirical Study of Earthquake Source Spectra for California Earthquakes," *Bulletin of the Seismological Society of America*, Vol. 87, No. 1, pp. 97-113.
- * Babcock, C.O and V.E. Hooker, 1977, *Results of Research to Develop Guidelines for Mining Near Surface and Underground Bodies of Water*, Information Circular 8741, U.S. Department of the Interior, Bureau of Mines, Pittsburgh, PA.
- Backer, R.R., R.A. Busch and L.A. Atkins, 1977, *Physical Properties of Western Coal Waste Materials*, Report of Investigations 8216, U.S. Department of the Interior, Bureau of Mines, Spokane, WA.
- Baecher, G.B. and J.T. Christian, 2003, *Reliability and Statistics in Geotechnical Engineering*, John Wiley & Sons, Hoboken, NJ.
- Bakun, W.H. and M.G. Hopper, 2004, "Magnitudes and Locations of the 1811-1812 New Madrid, Missouri, and the 1886 Charleston, South Carolina, Earthquakes," *Bulletin of the Seismological Society of America*, Vol. 94, No. 1, pp. 64-75.
- Bardet, J.P., 1997, *Experimental Soil Mechanics*, Prentice Hall, Upper Saddle River, NJ.
- Barfield, B.J., R.C. Warner and C.T. Haan, 1981, *Applied Hydrology and Sedimentology for Disturbed Areas*, Oklahoma Technical Press, Stillwater, OK.
- * Bartholomew, C.L., B.C. Murray and D.L. Goins, 1987, *Embankment Dam Instrumentation Manual*, U.S. Department of the Interior, Bureau of Reclamation, Denver, CO.
- * Bazán-Arias, N.C., S.R. Michalski, P.E. Glogowski and F. Howard, 2002, "In-place Solidification of Coal Tailings for Expressway Subgrade," *Proceedings, Tailings Dams 2002*, Las Vegas, Association of State Dam Safety Officials, Lexington, KY, pp. 129-140.
- Baziar, M.H. and R. Dobry, R., 1995, "Residual Strength and Large Deformation Potential of Loose Silty Sands," *Journal of Geotechnical Engineering*, ASCE, Vol. 121, No. 12, pp. 896-906.
- Becker, E., C.K. Chan and H.B. Seed, 1972, *Strength and Deformation Characteristics of Rockfill Materials in Plane Strain and Triaxial Compression Tests*, Report TE-72-3 to the California Department of Water Resources, University of California, Berkeley, CA.
- Bennett, O.L., E.L. Mathias, W.H. Armiger and J.N. Jones Jr., 1978, "Plant Materials and Their Requirements for Growth in Humid Regions," *Reclamation of Drastically Disturbed Land*, F.W. Schaller and P. Sutton, eds., American Society of Agronomy, Madison, WI, pp. 285-306.

Benson, R.C., R.A. Glaccum and M.R. Noel, 1984, *Geophysical Techniques for Sensing Buried Wastes and Waste Migration*, Report, Contract No. 68-03-3050, U.S. Environmental Protection Agency, Office of Research and Development, Environmental Monitoring Systems Laboratory, Las Vegas, NV.

Beresnev, I.A. and G.M. Atkinson, 1997, "Modeling Finite-Fault Radiation from ω^n Spectrum," *Bulletin of the Seismological Society of America*, Vol. 87, No. 1, pp. 67-84.

Bernreuter, D.L., J.B. Savy, R.W. Mensing and J.C. Chen, 1989, *Seismic Hazard Characterization of 69 Nuclear Plant Sites East of the Rocky Mountains: Methodology, Input Data and Comparisons to Previous Results for Ten Test Sites*, NUREG/CR-5250 (UCID-21517), U.S. Nuclear Regulatory Commission, Vols. 1-8.

Berube, A.P., 2004, *Investigating the Streaming Potential Phenomenon Using Electric Measurements and Numerical Modelling with Special Reference to Seepage Monitoring in Embankment Dams*, Doctoral Thesis, Lulea University of Technology, Department of Civil and Environmental Engineering, Division of Applied Geophysics, Lulea, Sweden.

Betoney, T.P., Jr., 1994, *MSHA Accident Investigation Report (Surface Area of an Underground Coal Mine), Non-Injury Impoundment (Coal Refuse Pile ID No. 1211WV30054-00)*, Arkwright No. 1 Mine, Consolidation Coal Company, Monongalia County, WV.

Bhabdaru, S. and O.P. Arora, 1987, "Vibrations in an Underground Coal Mine Due to Adjacent Surface Mine Blasts," *Proceedings, 2nd International Symposium on Rock Fragmentation by Blasting*, W.L. Fournery and R.D. Dick, eds., Society for Experimental Mechanics, Keystone, CO.

Biarez, J., J.L. Bordes and P. Londe, 1970, "La Fissuration des Noyaux des Barrages en Enrochments ou en Alluvion," *Proceedings, 10th International Congress on Large Dams*, Montreal, Canada, Vol. I, pp. 27-47.

* Bieniawski, Z.T., 1992, "A Method Revisited: Coal Pillar Strength Formula Based on Field Investigations," *Proceedings, Workshop on Coal Pillar Mechanics and Design*, Information Circular 9315, U.S. Department of the Interior, Bureau of Mines, Washington, DC, pp. 158-165.

Bieniawski, Z.T., 1989, *Engineering Rock Mass Classifications*, John Wiley & Sons, New York, NY.

Bieniawski, Z.T., 1987, *Strata Control in Mineral Engineering*, John Wiley & Sons, New York, NY.

Bieniawski, Z.T., 1968, "The Effect of Specimen Size on Compressive Strength of Coal," *International Journal of Rock Mechanics and Mining Sciences*, Vol. 5, pp. 325-335.

* Bigatel, A.J., G.R. Camus, D.W. Caylor, A.D. Dalberto and W.W. Hellier, 1999, *Engineering Manual for Mining Operations, Chapter 3: Sediment Control Impoundments and Coal Refuse Disposal Impoundments*, Pennsylvania Department of Environmental Protection, Bureau of Mining and Reclamation, Harrisburg, PA.

Bignell, V., 1977, "Case Study 2 - The Aberfan Failure," *Catastrophic Failures*, V. Bignell, G. Peters and C. Pym, eds., Open University Press.

Bishop, A.W., 1955, "The Use of the Slip Circle in the Stability Analyses of Slopes," *Géotechnique*, Vol. 5, No. 1, pp. 7-17.

Bishop, A.W. and D.J. Henkel, 1962, *The Measurements of Soil Properties in the Triaxial Test*, Edward Arnold, Ltd., London, England.

* Biswas, K., C. Mark and S.S. Peng, 1999, "A Unique Approach to Determining the Time-Dependent In Situ Strength of Coal Pillars," *Proceedings, 2nd Workshop on Coal Pillar Mechanics and Design*, NIOSH IC 9448, U.S. Department of Health and Human Services, National Institute for Occupational Safety and Health, Pittsburgh, PA, pp. 5-13.

* Biswas, K., S.S. Peng and P. Tsang, 1995, "Influence of Partings in a Coal Seam on Long Term Pillar Stability," *Proceedings, 14th International Conference on Ground Control in Mining*, West Virginia University, Morgantown, WV, pp. 80-93.

- Bjerrum, L., 1972, "Embankments on Soft Ground," *Proceedings, Specialty Conference on Performance of Earth and Earth-Supported Structures*, American Society of Civil Engineers (ASCE), Reston, VA, Vol. 2, pp. 1-54.
- Blackburn, J.T. and C.H. Dowding, 2004, "Finite-Element Analysis of Time Domain Reflectometry Cable-Grout-Soil Interaction," *Journal of Geotechnical and Geoenvironmental Engineering*, ASCE, Vol. 130, No. 3, pp. 231-239.
- Blight, G.E., 1968, "A Note on Field Vane Testing of Silty Soils," *Canadian Geotechnical Journal*, Vol. 5, No. 3, pp. 142-149.
- Bommer, J.J., N.A. Abrahamson, F.O. Strasser, A. Pecker, P.-Y. Bard, H. Bungum, F. Cotton, D. Fäh, F. Sabetta, F. Scherbaum and J. Studer, 2004, "The Challenge of Defining Upper Bounds on Earthquake Ground Motions," *Seismological Research Letters*, Vol. 75, No. 1, pp. 82-95.
- * Boulanger, R.W. and I.M. Idriss, 2004, "Evaluating the Potential for Liquefaction or Cyclic Failure of Silts and Clays," *Report No. UCD/CGM-04/01*, Center for Geotechnical Modeling, Department of Civil and Environmental Engineering, University of California, Davis, CA.
- Bowles, J.E., 1996, *Foundation Analysis and Design*, McGraw-Hill, New York, NY.
- Bradham, W.S. and F.T. Caruccio, 1995, *Sensitivity Analysis of Laboratory Based Mine Overburden Analytical Techniques for the Prediction of Acidic Mine Drainage*, U.S. Department of the Interior, Office of Surface Mining, Pittsburgh, PA.
- Brady, B.H.G. and E.T. Brown, 2004, *Rock Mechanics for Underground Mining*, Springer Publishing Company, New York, NY.
- Brady, K.B.C., M.W. Smith and J. Schueck, eds., 1998, *Coal Mine Drainage Prediction and Pollution Prevention in Pennsylvania*, Pennsylvania Department of Environmental Protection, Harrisburg, PA.
- Brady, K.B.C. and R.H. Hornberger, 1990, "The Prediction of Mine Drainage Quality in Pennsylvania," *Water Pollution Control Association of Pennsylvania Magazine*, Vol. 23, No. 5, pp. 8-15.
- Brater, E.F., H.W. King, J.E. Lindell and C.Y. Wei, 1996, *Handbook of Hydraulics*, 7th Ed., McGraw-Hill, New York, NY.
- British Columbia Acid Mine Drainage Task Force, 1989, *Draft Acid Rock Drainage Guide*, BiTech Publishers, Richmond, BC, Canada.
- * Brown, B.S. and G. Greenaway, 1999, "Field Experience in the Use of Wick Drains to Consolidate Soft Tailings," *Proceedings, Workshop on Stabilization of Soft Tailings, Part 2: Practice and Experience*, Chemnitz, Germany.
- * Brunner, D.J. and J.J. Schwoebel, 1999, "Directional Drilling for Methane Drainage and Exploration in Advance of Mining: Recent Advances and Applications," REI Drilling, Salt Lake City, UT.
- * Busch, R.A., R.R. Backer and L.A. Atkins, 1975, "Physical Property Data on Fine Coal Refuse," Report of Investigations 8062, U.S. Department of the Interior, Bureau of Mines, Pittsburgh, PA.
- * Busch, R.A., R.R. Backer and L.A. Atkins, 1974, "Physical Property Data on Coal Waste Embankment Materials," Report of Investigations 7964, U.S. Department of the Interior, Bureau of Mines, Pittsburgh, PA.
- Butler, D.K., J.L. Llopis, T.L. Dobecki, M.J. Wilt, R.F. Corwin and G. Olhoeft, 1990, "Comprehensive Geophysics Investigation of an Existing Dam Foundation: Engineering Geophysics Research and Development, Part 2," *Geophysics: The Leading Edge of Exploration*, Vol. 9, No. 9, pp. 44-53.
- Butler, D.K., J.L. Llopis and C.M. Deaver, 1989, "Comprehensive Geophysical Investigation of an Existing Dam Foundation," *Geophysics: The Leading Edge of Exploration*, Vol. 8, No. 8, pp. 10-18.

- Byrne, P.M., S.-S. Park, M. Beaty, M.K. Sharp, L. Gonzalez and T. Abdoun, 2004, "Numerical Modeling of Liquefaction and Comparison with Centrifuge Tests," *Canadian Geotechnical Journal*, Vol. 41, No. 2, pp. 193-211.
- Cai, S., 1983, "A Simple and Convenient Method for Design of Strength of Cemented Hydraulic Fill," *Proceedings, International Symposium on Mining with Backfill*, Lulea, Sweden, S. Granholm, ed., pp. 405-412.
- Campbell, K.W., 2003, "Prediction of Strong Ground Motion Using the Hybrid Empirical Method and Its Use in the Development of Ground-Motion (Attenuation) Relations in Eastern North America," *Bulletin of the Seismological Society of America*, Vol. 93, No. 3, pp. 1012-1033.
- Cannon, W.C., 1981, *MSHA Report of Investigation, Impoundment Accident (Failure of Refuse Pile), Preparation Plant, Island Creek Coal Company, Boone County, WV.*
- * Carlson, C.L. and D.C. Adriano, 1993, "Environmental Impacts of Coal Combustion Residues," *Journal of Environmental Quality*, Vol. 22, pp. 227-247.
- Carroll, R.G., Jr., 1983, "Geotextile Filter Criteria," *Engineering Fabrics in Transportation Construction*, Transportation Research Record 916, Transportation Research Board, Washington, DC, pp. 46-53.
- Carter, M. and S.P. Bentley, 1991, *Correlations of Soil Properties*, Pentech Press, London, U.K.
- Casagrande, A., 1971, "On Liquefaction Phenomena," *Géotechnique*, London, U.K., Vol. 21, No. 3, pp. 197-202.
- Castro, G., 2003, "Evaluation of Seismic Stability of Tailings Dams," *Proceedings, 12th Pan American Conference on Soil Mechanics and Geotechnical Engineering and 39th U.S. Rock Mechanics Symposium*, Cambridge, MA, pp. 2229-2234.
- Castro, G., 1995, "Empirical Methods in Liquefaction Evaluation," *Proceedings, First International Leonardo Zeevaert Conference*, Mexico City, Mexico, Vol. 1, pp. 1-41.
- Castro, G., 1994, "Seismically Induced Triggering of Liquefaction Failures," Performance of Ground and Soil Structures During Earthquakes, *Proceedings, Thirteenth International Conference on Soil Mechanics and Foundation Engineering*, New Delhi, India.
- Castro, G., 1975, "Liquefaction and Cyclic Mobility of Saturated Sands," *Journal of the Geotechnical Engineering Division*, ASCE, Vol. 101, No. GT6, pp. 551-569.
- Castro, G. and J.T. Christian, 1976, "Shear Strength of Soils and Cyclic Loading," *Journal of the Geotechnical Engineering Division*, ASCE, Vol. 102, No. GT9, pp. 887-894.
- Castro, G., R.B. Seed, T.O. Keller and H.B. Seed, 1992, "Steady State Strength Analysis of Lower San Fernando Slide," *Journal of Geotechnical Engineering*, ASCE, Vol. 118, No. 3, pp. 406-427.
- Caterpillar Tractor Company (Caterpillar), 2008, *Caterpillar Performance Handbook*, 38th Ed., Peoria, IL.
- Cedergren, H.R., 1989, *Seepage, Drainage and Flow Nets*, 3rd Ed., John Wiley & Sons, New York, NY.
- Canadian Geotechnical Society (CGS), 2007, *Canadian Foundation Engineering Manual*, 4th Ed., BiTech Publishers, Richmond, BC, Canada.
- Chamberlain, E.A.C. and D.A. Hall, 1973, "The Ambient Temperature Oxidation of Coal in Relation to the Early Detection of Spontaneous Heating – Part 2," *The Mining Engineer*, Vol. 132, No. 152, pp. 387-399.
- Chamberlain, E.A.C., D.A. Hall and J.T. Thirlaway, 1970, "The Ambient Temperature Oxidation of Coal in Relation to the Early Detection of Spontaneous Heating – Part 1," *The Mining Engineer*, Vol. 130, No. 121, pp. 1-16.
- Chandler, R.J., 1988, "The In-situ Measurement of the Undrained Shear Strength of Clays Using the Field Vane," *Vane Shear Strength Testing in Soils: Field and Laboratory Studies*, ASTM STP 1014, A.F. Richards, ed., American Society for Testing and Materials, West Conshohocken, PA, pp. 13-44.

- Chapman, M.C., J.W. Munsey, S.C. Whisner and J. Whisner, 2002, "The Eastern Tennessee Seismic Zone: Small Earthquakes Illuminating Major Basement Faults?" *Proceedings, GSA Joint Annual Meeting*, North-Central Section (36th) and Southeastern Section (51st), Lexington, KY, Session 21, Paper 21-9.
- * Chekan, G.J., 1985, *Design of Bulkheads for Controlling Water in Underground Mines*, Information Circular 9020, U.S. Department of the Interior, Bureau of Mines, Washington, DC.
- Chen, C.Y., 1979, "Engineering Properties of Coal Refuse," *Proceedings of the First International Symposium on Stability in Coal Mining*, C.O. Brawner and I.P.F. Dorling, eds., Miller Freeman Publications, San Francisco, CA, pp. 328-347.
- Chen, Z.Y. and N.R. Morgenstern, 1983, "Extensions to the Generalized Method of Slices for Stability Analysis," *Canadian Geotechnical Journal*, Vol. 20, No. 1, pp. 104-119.
- Choquet, P., M. Quirion and F. Juneau, 2000, "Advances in Fabry-Perot Fiber Optic Sensors and Instruments for Geotechnical Monitoring," *Geotechnical News*, BiTech Publishers, Richmond, BC, Canada, Vol. 18, No. 1, pp. 35-40.
- Chow, V.T., ed., 1964, *Handbook of Applied Hydrology*, McGraw-Hill, New York, NY.
- Chow, V.T., 1959, *Open-Channel Hydraulics*, McGraw-Hill, New York, NY.
- * Chugh, Y.P., R. Nath and S. Shankar, 1987, "Time-Dependent Behavior of Weak Floor Strata from an Illinois Coal Mine," *Proceedings, 6th International Conference on Ground Control in Mining*, West Virginia University, Morgantown, WV, pp. 204-218.
- Church, H.K., 1981, *Excavation Handbook*, McGraw-Hill, New York, NY.
- Clark, J.C., W.J. Johnson and W.A. Miller, 1994, "The Application of High Resolution Shear Wave Seismic Reflection Surveying to Hydrogeological and Geotechnical Investigations," *Proceedings, SAGEEP '94*, Environmental & Engineering Geophysical Society, Boston, MA.
- Clough, R.H., G.A. Sears and S.K. Sears, 2008, *Construction Project Management*, 5th Ed., John Wiley & Sons, New York, NY.
- Coalgate, J.L., D.J. Akers and R.W. Frum, 1973, *Gob Pile Stabilization, Reclamation, and Utilization*, U.S. Office of Coal Research, Research and Development Report No. 75, Interim Report No. 1, West Virginia University, Morgantown, WV.
- Coates, D., 1981, "Caving, Subsidence, and Ground Control," *Rock Mechanics Principles, Chapter 5*, Monograph No. 874, Canadian Centre for Mineral and Energy Technology, (CANMET), Canadian Government Publishing Centre, Ottawa, QC, Canada.
- Coates, D.F. and Y.S. Yu, 1977, *Pit Slope Manual, Chapter 9 – Waste Embankments*, Report No. 77-9, Canadian Centre for Mineral and Energy Technology (CANMET), Canadian Government Publishing Centre, Ottawa, QC, Canada.
- * Colorado School of Mines (CSM), 2007, *Void Detection Demonstrations at the Colorado School of Mines, Edgar Experimental Mine*, prepared for MSHA by the Western Mining Resource Center, CSM, Golden, CO.
- Contreras, I.A., A.T. Grosser and R.H. VerStrate, 2007, "The Use of the Fully-Grouted Method for Piezometer Installation," *Proceedings, Seventh International Symposium on Field Measurements in Geomechanics (FMGM 2007)*, Boston, J. DiMaggio and P. Osborn, eds., ASCE Special Publication 175, pp. 67-86.
- Cornell, C.A., 1968, "Engineering Seismic Risk Analysis," *Bulletin of the Seismological Society of America*, Vol. 58, No. 5, pp. 1583-1606.
- * Cowherd, D.C. and I.J. Corda, 1998, "Seismic Considerations for Upstream Construction of Coal Refuse Dams," *Proceedings, 1998 Annual Conference*, Las Vegas, Association of State Dam Safety Officials, Lexington, KY., pp. 523-534.

- * Cowherd, D.C., M.J. Carlson and M.T. Hardert, 2002, "A Method for Evaluation and Mitigation of the Potential for Mine Breakthrough in Fine Coal Refuse Tailings Dam Pool Areas," *Proceedings, Tailings Dams 2002*, Las Vegas, Association of State Dam Safety Officials, Lexington, KY, pp. 277-287.
- Cravotta, C.A. III, K.B.C. Brady, M.W. Smith, and R.L. Beam, 1990, "Effectiveness of Alkaline Addition at Surface Mines in Preventing or Abating Acid Mine Drainage: Part 1, Geochemical Considerations," *Proceedings, 1990 Mining and Reclamation Conference*, West Virginia University, Morgantown, WV, Vol. 1, pp. 221-226.
- * Crone, A.J. and R.L. Wheeler, 2000, *Data for Quaternary Faults, Liquefaction Features, and Possible Tectonic Features in the Central and Eastern United States, East of the Rocky Mountain Front*, USGS Open File Report 00-260, U.S. Department of the Interior, U.S. Geological Survey, Denver, CO.
- Cudworth, A.G., 1989, *Flood Hydrology Manual*, U.S. Department of the Interior, Bureau of Reclamation, Denver, CO.
- Daniel, D.E. and R.M. Koerner, 1995, *Quality Assurance and Quality Control For Waste Containment Facilities*, EPA/600/SR-93/182, U.S. Environmental Protection Agency, National Risk Management Research Laboratory, Cincinnati, OH.
- Daniels, W.L., 2005, "Effects of Cover Soil Thickness on Revegetation of Acidic Appalachian Coal Refuse," *Proceedings, 2005 National Meeting of the American Society of Mining and Reclamation*, Breckenridge, CO, ASMR, Lexington, KY, pp. 842-861.
- Daniels, W.L. and B.R. Stewart, 1993, "Reclamation and Closure of Coal Refuse Disposal Facilities in the Appalachians," *SME Preprint 93-169, Society of Mining, Metallurgy, and Exploration (SME) 1993 Annual Meeting*, Denver, CO.
- Daniels, W.L., B.R. Stewart, K. Haering and C. Zipper, 2002, "The Potential for Beneficial Reuse of Coal Fly Ash in Southwest Virginia Mining Environments," *Reclamation Guidelines for Surface Mined Land in Southwest Virginia*, Publication 460-134, Virginia Cooperative Extension, Powell River Project, Blacksburg, VA.
- Daniels, W.L., B.R. Stewart and D.C. Dove, 1996, *Reclamation of Coal Refuse Disposal Areas*, Publication 460-131, Virginia Cooperative Extension, Blacksburg, VA.
- * D'Appolonia, 2006, *Final Report, Demonstration Project – Mine Void Detection, DC Resistivity Surface Geophysical Method, Lots Branch Tailings Impoundment Site, Prenter, West Virginia*, Contract No. J53R/011, Mine Safety and Health Administration (MSHA), Arlington, VA.
- D'Appolonia, 1988, *Minimization of Coal Refuse Disposal Facility Related Water Quality Deterioration*, report prepared for U.S. Department of the Interior, Office of Surface Mining, Washington, DC.
- D'Appolonia, 1982, *Improved Resource Characterization for Coal Mining, Geophysics and Drilling Technology*, report prepared for U.S. Department of Energy, Office of Coal Mining, Contract No. USDOE AC22-80PC30114, DOE/PC/3011-4 (DE82016931).
- * D'Appolonia, 1980, *Environmental Effects of Slaking of Surface Mine Spoils, Eastern and Central U.S.*, report prepared for the U.S. Bureau of Mines, Contract No. J0285024, Pittsburgh, PA.
- D'Appolonia, 1973, *State-of-the-Art Study, Coal Waste Embankments in the United States*, Draft Report, Contract No. 50133042, U.S. Department of the Interior, Mining Enforcement and Safety Administration, Washington, DC.
- * Davies, M., E.C. McRoberts and T.I. Martin, 2002, "Static Liquefaction of Tailings – Fundamentals and Case Histories," *Proceedings, Tailings Dams 2002*, Las Vegas, ASDSO/USCOLD, pp. 233-255.
- Davies, W.E., J.F. Bailey and D.B. Kelly, 1972, *West Virginia's Buffalo Creek Flood: A Study of the Hydrology and Engineering Geology*, Circular 667, U.S. Department of the Interior, Geological Survey, Reston, VA.

- Davis, C.A. and J.P. Bardet, 1998, "Seismic Analysis of Large-Diameter Flexible Underground Pipes," *Journal of Geotechnical Engineering*, ASCE, Vol. 104, No. 10, pp. 1001-1015.
- Davis, G., 1973, "Comparison of Fall and Spring Plantings on Strip-Mine Spoils in the Bituminous Region of Pennsylvania," *Ecology and Reclamation of Devastated Land*, R.J. Hutnik and G. Davis, eds., Cordon and Breach, New York, NY, Vol. 1, pp. 525-538.
- Davis, A.P., G. Castro and S.J. Poulos, 1988, "Strengths Back-Figured from Liquefaction Case Histories," *Proceedings, Second International Conference on Case Histories in Geotechnical Engineering*, University of Missouri-Rolla, Rolla, MO, Vol. 3, pp. 1693-1701.
- Day, D.A. and N.B.H. Benjamin, 1991, *Construction Equipment Guide*, 2nd Ed., Wiley-Interscience, New York, NY.
- Dean, K.C. and R. Havens, 1972, "Comparative Costs and Methods for Stabilization of Tailings," *Tailings Disposal Today, Proceedings of the 1st International Tailing Symposium*, Tucson, AR, C.L. Aplin and G.O. George, eds., pp. 450-477.
- Degoutte, G. and J.J. Fry, 2002, "Geotextiles in Dams, Feedback," *Proceedings, Technical Symposium on Geotextiles and Geomembranes in Dams*, CFG and FCOLD.
- DiGioia, A.M., Jr. and R.E. Gray, 1979, "Power Plant Solid Wastes, Geotechnical Aspects of Disposal Site Selection and Design," *Current Geotechnical Practice in Mine Waste Disposal*, ASCE, pp. 113-180.
- DiGioia, A.M., Jr., G.G. Brendel, D.J. Spaeder, N.J. Balsamo and L.C. Shumway, 1995, *Coal Fly Ash Design Manual*, 3rd Ed., EPRI-TR-104137, Electric Power Research Institute, Palo Alto, CA.
- * Department of Defense (DOD), 2005, *Unified Facilities Criteria: Geotechnical Engineering Procedures for Foundation Design of Buildings and Structures*, UFC 3-220-01N, U.S. Government Printing Office, Washington, DC.
- Dove, D.C., W.L. Daniels and J. Bell, 1987, "Reclamation of Coal Wastes with Reduced Soil Depth and Other Amendments," *Proceedings, 4th Biennial Symposium on Surface Mining and Reclamation on the Great Plains*, Billings, MT, American Society of Mining and Reclamation, Lexington, KY, pp. 1-9.
- * Dowding, C.H., 2002, "Geo-Measurements with Metallic TDR Cable Technology for Infrastructure Surveillance," *TRB 2002 Annual Meeting CD-ROM*, Washington, DC.
- Dowding, C.H. and K.M. O'Connor, 2000, "Comparison of TDR and Inclinometers for Slope Monitoring," *Geotechnical Measurements: Lab and Field*, Geotechnical Special Publication No. 106, W.A. Marr, ed., ASCE, Reston, VA, pp. 80-90.
- DuMontelle, P.B., S.C. Bradford, R.A. Bauer and M.M. Killey, 1981, "Mine Subsidence in Illinois: Facts for the Homeowner Considering Insurance," *Environmental Geology Notes*, Illinois State Geological Survey, Champaign, IL.
- Duncan, J.M., 1996, "State of the Art: Limit Equilibrium and Finite Element Analysis of Slopes," *Journal of Geotechnical Engineering*, ASCE, Vol. 122, No. 7, pp. 577-596.
- Duncan, J.M. and S.G. Wright, 2005, *Soil Strength and Slope Stability*, John Wiley & Sons, Hoboken, NJ.
- Duncan, J.M. and S.G. Wright, 1980, "The Accuracy of Equilibrium Methods of Slope Stability Analysis," *Engineering Geology*, Vol. 16, No. 1, pp. 5-17.
- Dunnicliff, J., 1997, "Systematic Approach to Planning Monitoring Programs Using Geotechnical Instrumentation – An Update," *Geotechnical News*, BiTech Publishers, Richmond, BC, Canada, Vol. 15, No. 3, pp. 36-46.
- Dunnicliff, J., 1993, *Geotechnical Instrumentation for Monitoring Field Performance*, John Wiley & Sons, New York, NY.

Dunncliff, J., 1981, "Long-Term Performance of Embankment Dam Instrumentation," *Recent Development in Geotechnical Engineering for Hydro Projects*, F.H. Kulhawy, ed., ASCE, New York, NY, pp. 1-22.

* Dunrud, C. and F. Osterwald, 1980, *Effects of Coal Mine Subsidence in the Sheridan, Wyoming, Area*, Professional Paper No. 1164, U.S. Geological Survey, Denver, CO.

Eger, P., 1994, "Wetland Treatment for Trace Metal Removal from Mine Drainage: The Importance of Aerobic and Anaerobic Processes," *Water Science and Technology*, Vol. 29, No. 4, pp. 249-256.

Eigenbrod, W.F., 1971, "Use of Stabilizers and Binders for Conditioning Surface-Mined Land and Coal Mine Refuse for Revegetation," *Proceedings, Revegetation and Economic Use of Surface-Mined Land and Mine Refuse Symposium*, West Virginia University, Morgantown, WV, pp. 46-47.

* Ellefsen, K.J., G.J. Tuttle, J.M. Williams and J.E. Lucius, 2005, *S-Wave Refraction Survey of Alluvial Aggregate*, Scientific Investigations Report 2005-5012, U. S. Geological Survey, Denver, CO.

* Ellison, R.D. and Y.Y. Cho, 1976, "Liquefaction Considerations for Fine Coal Refuse," Ohio River Valley Soils Seminar, Lexington, KY.

Electric Power Research Institute (EPRI), 1989, *Seismic Hazard Methodology for the Central and Eastern United States*, Report NP-4726.

El-Ramly, H., N.R. Morgenstern and D.M. Cruden, 2003, "Probabilistic Stability Analysis of a Tailings Dyke on Presheared Clay-Shale," *Canadian Geotechnical Journal*, Vol. 40, pp. 192-208.

Federal Emergency Management Agency (FEMA), pending publication (2009), "Geotextiles in Embankment Dams, Status Report on the Use of Geotextiles in Embankment Dam Construction and Rehabilitation."

* Federal Emergency Management Agency (FEMA), 2007, *Technical Manual: Plastic Pipe Used in Embankment Dams (Best Practices for Design, Construction, Problem Identification, and Evaluation, Inspection, Maintenance, Renovation, and Repair)*, FEMA P-675, U.S. Department of Homeland Security, FEMA, Washington, DC.

* Federal Emergency Management Agency (FEMA), 2005a, *Technical Manual: Conduits through Embankment Dams (Best Practices for Design, Construction, Problem Identification and Evaluation, Inspection, Maintenance, Renovation, and Repair)*, FEMA 484, U.S. Department of Homeland Security, FEMA, Washington, DC.

* Federal Emergency Management Agency (FEMA), 2005b, *Federal Guidelines for Dam Safety, Earthquake Analyses and Design of Dams*, FEMA 65, U.S. Department of Homeland Security, FEMA, Washington, DC.

* Federal Emergency Management Agency (FEMA), 2004a, *Federal Guidelines for Dam Safety: Hazard Potential Classification System for Dams*, FEMA 333, Interagency Committee on Dam Safety (ICODS), Washington, DC.

* Federal Emergency Management Agency (FEMA), 2004b, *Federal Guidelines for Dam Safety: Emergency Action Planning for Dam Owners*, FEMA 64, U.S. Department of Homeland Security, FEMA, Washington, DC.

* Federal Emergency Management Agency (FEMA), 2004c, *Federal Guidelines for Dam Safety: Selecting and Accommodating Inflow Design Floods for Dams*, FEMA 94, U.S. Department of Homeland Security, FEMA, Washington, DC.

* Federal Highway Administration (FHWA), 2006, *Hydraulic Design of Energy Dissipators for Culverts and Channels*, Hydraulic Engineering Circular No. 14, 3rd Ed., FHWA-NHI-06-086, U.S. Department of Transportation, FHWA, National Highway Institute, Arlington, VA.

* Federal Highway Administration (FHWA), 2005a, *Design of Roadside Channels with Flexible Linings*, Hydraulic Engineering Circular No. 15 (HEC-15), FHWA-NHI-05-114, U.S. Department of Transportation, FHWA, National Highway Institute, Arlington, VA.

References

- * Federal Highway Administration (FHWA), 2005b, *Hydraulic Design of Highway Culverts*, Hydraulic Design Series No. 5 (HDS-5), FHWA-NHI-01-020, U.S. Department of Transportation, FHWA, National Highway Institute, Arlington, VA.
 - * Federal Highway Administration (FHWA), 2002, *Subsurface Investigations: Geotechnical Site Characterization*, Reference Manual for NHI Course No. 132031, FHWA-NHI-01-031, U.S. Department of Transportation, FHWA, Washington, DC.
 - * Federal Highway Administration (FHWA), 2001, *Introduction to Highway Hydraulics*, Hydraulic Design Series No. 4 (HDS-4), FHWA-NHI-01-019, U.S. Department of Transportation, FHWA, Washington, DC.
 - * Federal Highway Administration (FHWA), 1992, *The Cone Penetrometer Test*, FHWA-SA-91-043, U.S. Department of Transportation, FHWA, Washington, DC.
 - * Federal Highway Administration (FHWA), 1989, *Design of Riprap Revetment*, Hydraulic Engineering Circular No. 11, FHWA-IP-89-016, U.S. Department of Transportation, FHWA, Washington, DC.
 - * Federal Highway Administration (FHWA), 1961, *Design Charts for Open-Channel Flow*, Hydraulic Design Series No. 3 (HDS-3), FHWA-EPD-86-102, U.S. Department of Transportation, FHWA, Washington, DC.
 - * Federal Energy Regulatory Commission (FERC), 2001, "Chapter VIII, Determination of the Probable Maximum Flood," *Engineering Guidelines for the Evaluation of Hydropower Projects*, U.S. Department of Energy, FERC, Washington, DC.
 - * Federal Energy Regulatory Commission (FERC), 1993, "Chapter II, Selecting and Accommodating Inflow Design Floods for Dams," *Engineering Guidelines for the Evaluation of Hydropower Projects*, U.S. Department of Energy, FERC, Washington, DC.
- Fell, R., P. MacGregor, D. Stapledon and G. Bell, 2005, *Geotechnical Engineering of Dams*, A.A. Balkema Publishers, London, UK.
- Fellenius, W., 1922, *Bulletin 2*, Swedish State Railway Geotechnical Commission, Stockholm, Sweden.
- Ferguson, K.D. and K.A. Morin, 1991, "The Prediction of Acid Rock Drainage – Lessons from the Database," *Proceedings, 2nd International Conference on Abatement of Acidic Drainage*, Montreal, Canada, Vol. 3, pp. 85-106.
- Ferguson, K.D. and J.D. Robertson, 1994, "Assessing the Risk of ARD," *Proceedings, 3rd International Conference on Abatement of Acidic Drainage*, Pittsburgh, PA, U.S. Bureau of Mines Special Publication SP 06A-94, Vol. 1, pp. 2-11.
- Fernandez, L.M. and P.K. Van Der Heever, 1996, "Ground Movement and Damage Accompanying a Large Seismic Event in the Klerksdorp District," *Proceedings, 1st International Congress on Rockbursts and Seismicity in Mines*, N.C. Gay and E.H. Wainwright, eds., Johannesburg, South Africa, pp. 193-198.
- Filipek, L.H., J. T. Gormley, R. Ewing and D. Ellsworth, 1991, "Kinetic Acid-Prediction Studies as Aids to Waste Rock and Water Management during Advanced Exploration of a Massive Sulfide Deposit," *Proceedings, 2nd International Conference on Abatement of Acidic Drainage*, Montreal, Canada, CANMET, Ottawa, Vol. 3, pp. 191-208.
- Finn, W.D.L., K.W. Lee and G.R. Martin, 1977, "An Effective Stress Model for Liquefaction," *Journal of the Geotechnical Engineering Division*, ASCE, Vol. 103, No. GT6, pp. 517-533.
- Fiscor, S., 2002, "Design Alternatives for Refuse Disposal," *Coal Age*, Vol. 107, No. 5, pp. 34-36.
- Fourie, A.B. and R.W. Green, 1993, "Damage to Underground Coal Mines Caused by Surface Blasting," *International Journal of Surface Mining, Reclamation and Environment*, Vol. 7, No. 1, pp. 11-16.

Forrester, P.J. and B.H. Whitaker, 1976, "Effects of Mining Subsidence on Colliery Spoil Heaps – I and II," *International Journal of Rock Mechanics, Mining Sciences and Geomechanics Abstracts*, No. 13, pp. 113-133.

* France, J.W., 2004, "Seepage Collection and Control Systems: The Devil is in the Details," *Proceedings, 2004 ASDSO Annual Conference*, Phoenix, Association of State Dam Safety Officials, Lexington, KY.

Frankel, A., 1995, "Mapping Seismic Hazard in the Central and Eastern United States," *Seismological Research Letters*, Vol. 66, No. 4, pp. 8-21.

* Frankel, A.D., M.D. Petersen, C.S. Mueller, K.M. Haller, R.L. Wheeler, E.V. Leyendecker, R.L. Wesson, S.C. Harmsen, C.H. Cramer, D.M. Perkins and K.S. Rukstales, 2002, *Documentation for the 2002 Update of the National Seismic Hazard Maps*, USGS Open-File Report 02-420, Denver, CO.

Frankel, A.D., C. Mueller, T. Barnhard, D. Perkins, E.V. Leyendecker, N. Dickman, S. Hanson and M. Hopper, 1996, *National Seismic-Hazard Maps: Documentation - June 1996*, USGS Open-File Report 96-532, U.S. Department of the Interior, Geological Survey, Denver, CO.

Franklin, J.A. and R. Chandra, 1972, "The Slake Durability Test," *International Journal of Rock Mechanics and Mining Sciences*, Vol. 9, pp. 325-341.

Fread, D.L., 1988, *The NWS DAMBRK Model: Theoretical Background and User Documentation*, Report No. HRL-258, U.S. Department of Commerce, National Oceanic and Atmospheric Administration, National Weather Service, Hydrological Research Laboratory, Silver Spring, MD.

Frederick, R.H. and J.F. Miller, 1979, "Short Duration Rainfall Frequency Relations for California," *Preprint Volume, Third Conference on Hydrometeorology*, American Meteorological Society, Boston, MA, pp. 67-73.

* Frederick, R.H., V.A. Myers and E.P. Auciello, 1977, *Five- to 60-Minute Precipitation Frequency for the Eastern and Central United States*, NOAA Technical Memo NWS HYDRO-35, U.S. Department of Commerce, National Oceanic and Atmospheric Administration, NWS, Washington, DC.

Fredland, J.W., 2008, personal communication concerning MSHA's position of hydrologic design criteria for temporary mining operations.

* Frischknecht, F.C. and P.V. Raab, 1984, *Location of Abandoned Wells with Geophysical Methods*, Report No. 600/4-84-085, U.S. Department of the Environment, USEPA, Washington, DC.

Frischknecht, F.C., R. Grette, P.V. Raab, and J. Meredith, 1985, *Location of Abandoned Wells by Magnetic Surveys – Acquisition and Interpretation of Aeromagnetic Data for Five Test Areas*, Open-File Report 85-614-A, U.S. Department of the Interior, Geological Survey, Denver, CO.

Gamble, J.C., 1971, *Durability-Plasticity Classification of Shales and Other Argillaceous Rocks*, Ph.D. Thesis, University of Illinois, Champaign, IL.

Gan, Y., 2005, RES3DINV, *Rapid 3D Resistivity and IP Inversion Using the Least-Squares Method*, Geotomo Software, available from Geotomo web site.

Gan, Y., 2004, RES2DINV, *Rapid 2D Resistivity and IP Inversion Using the Least-Squares Method*, Geotomo Software, available from Geotomo web site.

Ganow, H., 1975, *A Geotechnical Study of the Squeeze Problem Associated with the Underground Mining of Coal*, Doctoral Thesis, University of Illinois, Urbana-Champaign, IL.

* Gardner, G.H. and K.K. Wu, 2002, "Challenges Associated with Evaluating the Liquefaction Potential of Coal Waste Impoundments Subject to Seismic Loading," *Proceedings, Tailings Dams 2002*, Las Vegas, Association of State Dam Safety Officials, Lexington, KY, pp. 207-218.

Garret, W.S. and L.T. Campbell Pitt, 1961, "Design and Construction of Underground Bulkheads and Water Barriers," *Transactions, 7th Commonwealth Mining and Metallurgical Congress*, South African Institute of Mining and Metallurgy, pp. 1283-1301.

- GEI Consultants, 2007, personal communication regarding experience with testing coal refuse.
- * Genes, B.E., T.O. Keller, and J.P. Laird, 2000, "Steady State Liquefaction Susceptibility of High Hazard Upstream-Constructed Coal Refuse Disposal Facilities," *Proceedings, Tailings Dams 2000*, Las Vegas, ASDSO/USCOLD, pp. 47-58.
- Gentile, L.F., K.W. Cargill, and S.D. McGarvie, 1997, "Enhanced Cover Methods for Surface Coal Refuse Reclamation," *Proceedings, 14th Annual Meeting, American Society for Surface Mining and Reclamation*, Austin, TX, pp. 299-308.
- Giroud, J.P., 1997, "Geotextile Filters: Reliable Design and Installation," *Proceedings, Recontres 97*, Reims, France, Vol.1, pp. 170-196.
- Graf, J.B., G. Garklavs and K.A. Oberg, 1982, *Time of Concentration and Storage Coefficient Values for Illinois Streams*, Water Resources Investigation Report 82-13, U.S. Department of the Interior, U.S. Geological Survey, Water Resources Division, Urbana, IL.
- Gray, D.H. and Y Lin, 1972, "Engineering Properties of Compacted Fly Ash," *Journal of the Soil Mechanics and Foundations Division*, ASCE, Vol. 98, No. 4, pp. 361-380.
- * Gray, R.E., R.W. Bruhn and R.J. Turka, 1977, *Study and Analysis of Surface Subsidence over the Mined Pittsburgh Coalbed*, Report No. PB-281511, Contract No. J0366047, U.S. Department of the Interior, Bureau of Mines, Denver, CO.
- * Geosynthetic Research Institute (GRI), 2005, *Test Methods, Required Properties, and Testing Frequencies of Geosynthetic Clay Liners (GCLs)*, Standard Specification GRI-GCL3, Folsom, PA.
- Griffiths, D.V. and P.A. Lane, 1999, "Slope Stability Analysis by Finite Elements," *Géotechnique*, Vol. 49, No. 3, pp. 387-403.
- * Gritto, R., 2003, "Subsurface Void Detection Using Seismic Tomographic Imaging," presented at Geophysical Technologies for Detecting Underground Coal Mines Interactive Forum, Lexington, KY, Paper LBNL-53227, Lawrence Berkeley National Laboratory, University of California, Berkeley, CA.
- Guang-Xu, T. and H. Mao-Yuan, 1983, "Assessment of Support Ability of the Fill Mass," *Proceedings, International Symposium on Mining and Backfill*, Lulea, Sweden, S. Granholm, ed., pp. 433-442.
- Guney, M., 1968, "Oxidation and Spontaneous Combustion of Coal: A Review of Individual Factors," *Colliery Guardian*, Vol. 216, pp. 105-110.
- Gupta, B.K., R. Gross and P. Bethell, 2008, "Replacement of Belt Presses with a Deep Cone Thickener at Lone Mountain Processing," *Proceedings, Coal Prep Annual Coal Processing Exhibition and Conference*, Coal Preparation Society of America, Lexington, KY.
- Haan, C.T. and B.J. Barfield, 1978, *Hydrology and Sedimentology of Surface Mined Lands*, Institute for Mining and Minerals Research, Kentucky Center for Energy Research Laboratory, College of Engineering, University of Kentucky Press, Lexington, KY.
- * Haeni, F.P., 1988, "Application of Seismic-Refraction Techniques to Hydrologic Studies," *Techniques of Water-Resources Investigations of the United States Geological Survey*, TWRI 2-D2, U.S. Department of the Interior, Geological Survey, Denver, CO.
- Hanks, T.C. and H. Kanamori, 1979, "A Moment Magnitude Scale," *Journal of Geophysical Research*, Vol. 84, No. B5, pp. 2348-2350.
- Hanks, T.C. and R.K. McGuire, 1981, "The Character of High Frequency Strong Ground Motion," *Bulletin of the Seismological Society of America*, Vol. 71, No. 6, pp. 2071-2095.
- Hanna, T.H., 1985, *Field Instrumentation In Geotechnical Engineering*, Trans Tech Publications, Rockford, MA.

Harder, L.F. Jr., 1991, "Performance of Earth Dams During the Loma Prieta Earthquake," *Proceedings of the Second International Conference on Recent Advances in Geotechnical Earthquake Engineering and Soil Dynamics*, University of Missouri-Rolla, Vol. II, pp. 1613-1629.

Harder, L.F., Jr. and R.W. Boulanger, 1997, "Application of K_o and K_a Correction Factors," *Proceedings, NCEER Workshop on Evaluation of Liquefaction Resistance of Soils*, T.L. Youd and I.M. Idriss, eds., NCEER-97-0022, National Center for Earthquake Engineering Research, SUNY, Buffalo, pp. 167-190.

Harmsen, S., D. Perkins, and A. Frankel, 1999, "Deaggregation of Probabilistic Ground Motions in the Central and Eastern United States," *Bulletin of the Seismological Society of America*, Vol. 89, No. 1, pp. 1-13.

Harr, M.E., 1962, *Groundwater and Seepage*, McGraw-Hill, New York, NY.

Harteis, S.P. and D.R. Dolinar, 2006, "Water and Slurry Bulkheads in Underground Coal Mines: Design, Monitoring and Safety Concerns," *Mining Engineering*, Vol. 58, No. 12, pp. 41-47.

* Harteis, S.P., D.R. Dolinar and T.M. Taylor, 2008, *Guidelines for Permitting Construction, and Monitoring of Retention Bulkheads for Underground Coal Mines*, Information Circular 9506, U.S. Department of the Interior, National Institute for Occupational Health and Safety, Pittsburgh, PA.

Hartman, H.L., ed., 1992, *Mining Engineering Handbook*, 2nd Ed., Society for Mining, Metallurgy, and Exploration (SME), Littleton, CO.

Haxo, H.E., Jr., "Quality Assurance of Geomembranes Used as Linings for Hazardous Waste Containment," *Geotextiles and Geomembranes*, International Geosynthetics Society, Vol. 3, No. 4, pp. 225-247.

Head, K.H., 1986, *Manual of Soil Laboratory Testing, Volume 3: Effective Stress Tests*, Pentech Press, London, UK.

Head, K.H., 1982, *Manual of Soil Laboratory Testing, Volume 2: Permeability, Shear Strength and Compressibility Tests*, Pentech Press, London, UK.

Head, K.H., 1980, *Manual of Soil Laboratory Testing, Volume 1: Soil Classification and Compaction Tests*, Pentech Press, London, UK.

* Hedin, R.S., G.R. Watzlaf and R.W. Naim, 1994, "Passive Treatment of Acid Mine Drainage with Limestone," *Journal of Environmental Quality*, Vol. 23, No. 6, pp. 1338-1345.

* Hedin, R.S., R.W. Naim and R.L.P. Kleinmann, 1993, *Passive Treatment of Coal Mine Drainage*, Information Circular 9389, U.S. Department of the Interior, Bureau of Mines, Pittsburgh Research Center, Pittsburgh, PA.

* Hegazy, Y.A., A.G. Cushing and C.J. Lewis, 2004, "Physical, Mechanical, and Hydraulic Properties of Coal Refuse for Slurry Impoundment Design," *Proceedings, 2nd International Site Characterization Conference*, Porto, Portugal.

Henderson, F.M., 1966, *Open Channel Flow*, The Macmillan Company, New York, NY.

Henry, C.D., 2007, "Fine Coal Recovery Plant Installation: Smith Branch Impoundment – Pinnacle Mining," *Proceedings, Coal Prep Annual Coal Processing Exhibition and Conference*, Coal Preparation Society of America, Lexington, KY.

* Hershfield, D.M., 1961, *Rainfall Frequency Atlas of the United States for Durations from 30 Minutes to 24 Hours and Return Periods from 1 to 100 Years*, Technical Paper No. 40, U.S. Department of Commerce, Weather Bureau, Washington, DC.

Herzog B.L., 1994, "Slug Tests for Determining Hydraulic Conductivity of Natural Geologic Deposits," *Hydraulic Conductivity and Waste Contaminant Transport In Soil: ASTM STP 1142*, D.E. Daniel and S.J. Trautwein, eds., ASTM, Philadelphia, PA, pp. 95-110.

Himelick, E.B., 1981, *Tree and Shrub Transplanting Manual*, 2nd Ed., International Society of Arboriculture, Champaign, IL.

- Hoek, E., 2000, *Practical Rock Engineering*, Rocscience, Toronto, Ontario, Canada.
- Holtz, R.D. and W.D. Kovacs, 1981, *Introduction to Geotechnical Engineering*, Prentice-Hall, Englewood Cliffs, NJ.
- * Holtz, R.D., B.R. Christopher and R.R. Berg, 1998, *Geosynthetic Design and Construction Guidelines*, DTFH61-93-C-00120, Federal Highway Administration (FHWA), National Highway Institute, Washington, DC.
- Houlsby, A.C., 1990, *Construction and Design of Cement Grouting – A Guide To Grouting In Rock Foundations*, John Wiley & Sons, New York, NY.
- Howard, A.K. and J.L. Hitch, eds., 1998, *The Design and Application of Controlled Low-Strength Materials (Flowable Fill)*, ASTM STP 1331, American Society for Testing and Materials, West Conshohocken, PA.
- * Huang, Y.H., J. Li and G. Weeratunga, 1987, "Strength and Consolidation Characteristic of Fine Coal Refuse," University of Kentucky, Lexington, KY.
- Hunt, R.E., 1986, *Geotechnical Engineering Practices*, McGraw-Hill, New York, NY.
- Hustrulid, W.A., 1976, "A Review of Coal Pillar Strength Formulas," *Rock Mechanics*, Vol. 8, No. 2, pp. 115-145.
- Hutchison, I.P.G. and R.D. Ellison, eds., 1992, *Mine Waste Management: A Resource for Mining Industry Professionals, Regulators and Consulting Engineers*, Lewis Publishers, Chelsea, MI.
- Hvorslev, J., 1948, *Subsurface Exploration and Sampling of Soils for Civil Engineering Purposes*, U.S. Department of the Army, Corps of Engineers, Waterways Experiment Station, Vicksburg, MS.
- * Hynes-Griffin, M.E. and A.G. Franklin, A.G., 1984, *Rationalizing the Seismic Coefficient Method*, Miscellaneous Paper GL-84-13, U.S. Department of the Army, Corps of Engineers, Waterways Experiment Station, Vicksburg, MS.
- * Idriss, I.M. and R.W. Boulanger, 2007, "Residual Shear Strength of Liquefied Soil," *Proceedings, Modernization and Optimization of Existing Dams and Reservoirs*, 27th Annual USSD Conference, Denver, CO, pp. 621-634.
- Indraratna, B. and S. Radampola, 2002, "Analysis of Critical Hydraulic Gradient for Particle Movement in Filtration," *Journal of Geotechnical and Geoenvironmental Engineering*, ASCE, Vol. 128, No. 4, pp. 337-350.
- Jaeger, J.C., N.G.W. Cook and R. Zimmerman, 2007, *Fundamentals of Rock Mechanics*, 4th Ed., John Wiley & Sons (Blackwell Publishing), Hoboken, NJ.
- Jáky, J., 1944, "The Coefficient of Earth Pressure at Rest," *Journal for Society of Hungarian Architects and Engineers*, Budapest, Hungary, pp. 355-358.
- Janbu, N., 1973, "Slope Stability Computations," *Embankment-Dam Engineering: Casagrande Volume*, R.C. Hirschfeld and S.J. Poulos, eds., John Wiley & Sons, Hoboken, NJ, pp. 47-86.
- * Johnson, W.J., 2003, "Applications of the Electrical Resistivity Method for Detection of Underground Mine Workings," *Proceedings, Workshop on Geophysical Technologies for Detecting Underground Coal Mine Voids*, Lexington, KY.
- * Johnson, W.J. and J.C. Clark, 1992, *High Resolution Shear Wave Surveying for Hydrogeological Investigations*, Report No. DOE/CH-9211 (Contract No. 02112405 with Argonne National Laboratory), U.S. Department of Energy, Washington, DC.
- * Johnson, W.J., R.E. Snow and J.C. Clark, 2002, "Surface Geophysical Methods for the Detection of Underground Mine Workings," *Proceedings, Symposium on Geotechnical Methods for Mine Mapping Verifications*, Charleston, WV.

* Jolley, T.R. and H.W. Russell, 1959, *Control of Fires in Inactive Coal Deposits in Western U.S. Including Alaska*, 1948-1958, Report No. BM-IC-7932, U.S. Department of the Interior, Bureau of Mines, Washington, DC.

Jones, C.L., J.D. Higgins and R.D. Andrew, 2000, *Colorado Rockfall Simulation Program, Version 4.0*, Colorado Department of Transportation, Colorado Geological Survey, Denver, CO.

* Kalamaras, G.S. and Z.T. Bieniawski, 1993, "A Rock Mass Strength Concept for Coal Seams," *Proceedings, 12th International Conference on Ground Control in Mining*, West Virginia University, Morgantown, WV, pp. 274-283.

Kalinski, M.E. and J.L. Phillips, 2008, "Development of Methods to Predict Dynamic Behavior of Fine Tailings: Preliminary Results from Two Sites in Appalachia," *Geotechnical Special Publication No. 181*, Geotechnical Earthquake Engineering and Soil Dynamics IV, D. Zeng, M.T. Manzari and D.R. Hiltunen, eds., American Society of Civil Engineers (ASCE), Reston, VA.

Kanamori, H., 1977, "The Energy Release in Great Earthquakes," *Journal of Geophysical Research*, Vol. 82, No. B20, pp. 2981-2987.

Karmis, M., 2003, "Milos Statement – Sustainable Development Conference Held in Greece," *Mining Engineering*, Society of Mining, Metallurgy, and Exploration (SME), Littleton, CO, Vol. 55, No. 8, pp. 31-32.

Karmis, M. and Z. Agioutantis, 2004, "A Risk Analysis Subsidence Approach for the Design of Coal Refuse Impoundments Overlying Mine Workings," *Proceedings, 8th International Symposium on Environmental Issues and Waste Management in Energy and Mineral Production (SWEMP)*, Antalya, Turkey, pp. 205-210.

Kashef, A.I., 1986, *Groundwater Engineering*, McGraw-Hill, New York, NY,

* Kaufman, W.W. and J.C. Ault, 1977, *Design of Surface Mine Haulage Roads – A Manual*, BM-IC-8758, U.S. Department of the Interior, Bureau of Mines, Washington, DC.

* Kendorski, F. S., 2006, "Effect of Full-Extraction Underground Mining on Ground and Surface Waters: A 25-Year Retrospective," *Proceedings, 25th International Conference on Ground Control in Mining*, West Virginia University, Morgantown, WV, pp. 425-430.

* Kendorski, F. S., 1993, "Effect of High-Extraction Coal Mining on Surface and Ground Water," *Proceedings, 12th International Conference on Ground Control in Mining*, West Virginia University, Morgantown, WV, pp. 412-425.

* Kendorski, F.S., I. Khosla and M.M. Singh, 1979, *Criteria for Determining When a Body of Surface Water Constitutes a Hazard to Mining*, Final Report, Contract J0285011, U.S. Department of the Interior, Bureau of Mines, Pittsburgh, PA.

* Kepler, D.A. and E.C. McCleary, 1994, "Successive Alkalinity-Producing Systems (SAPS) for Treatment of Acid Mine Drainage," *Proceedings, International Land Reclamation and Mine Drainage Conference*, SP06A-94, U.S. Department of the Interior, Bureau of Mines, Pittsburgh, PA, pp. 196-204.

Keys, W.S., 1997, *A Practical Guide to Borehole Geophysics in Environmental Investigations*, CRC Press, Boca Raton, FL.

* Kim, A.G. and R.F. Chaiken, 1993, *Fires in Abandoned Coal Mines and Waste Banks*, Information Circular No. 9352, U.S. Department of the Interior, Bureau of Mines, Washington, DC.

Kim, A.G. and R.F. Chaiken, 1990, "Relative Self-Heating Tendencies of Coal, Carbonaceous Shales and Coal Refuse," *Proceedings, 1990 Mining and Reclamation Conference and Exhibition*, J. Skousen and J. Sencindiver, eds., West Virginia University, Morgantown, WV.

* Kim, A.G. and A.M. Kociban, 1994, "Cryogenic Slurry Method to Extinguish Waste Bank Fires," *Proceedings, International Land Reclamation and Mine Drainage Conference*, U.S. Department of the Interior, Bureau of Mines, Pittsburgh, PA, pp. 129-138.

- Kirkwood, D.T. and K.K. Wu, 1995, "Technical Considerations for the Design and Construction of Mine Seals to Withstand Hydraulic Heads in Underground Mines," *SME Preprint No. 95-100*, Society for Mining, Metallurgy, and Exploration (SME) Annual Meeting, Denver, CO.
- * Kleinmann, R.L.P., ed., 2000, *Prediction of Water Quality at Surface Coal Mines*, National Mine Reclamation Center, West Virginia University, Morgantown, WV.
- Koerner, R.M., 2006, *Designing with Geosynthetics*, 5th Ed., Prentice Hall, Upper Saddle River, NJ.
- * Koerner, R.M. and G.R. Koerner, 2005, "GSI White Paper #4, Reduction Factors Used in Geosynthetic Design," *GFR Magazine*, Vol. 23, No. 2 (February 2005). Revised version (2007) available from the Geosynthetic Institute, Folsom, PA.
- * Kohli, K. and F. Block, 2007, *Guidance Manual: Outcrop Barrier Design for Above Drainage Coal Mines*, U.S. Department of the Interior, Office of Surface Mining, Washington, DC.
- Kravits, S.J. and J.J. Schwoebel, 1994, Directional Drilling Techniques for Exploration in Advance of Mining," *World Mining Equipment*, Vol. 18, No. 1, pp. 24-28.
- Krinitzky, E.L., 2002, "How to Obtain Earthquake Ground Motions for Engineering Design," *Engineering Geology*, Vol. 65, No. 1, pp.1-16.
- * Krinitzky, E. L., 1995, *State-of-the-Art for Assessing Earthquake Hazards in the United States: Selection of Earthquake Ground Motions for Engineering*, Miscellaneous Paper S-73-1, Report 29, U.S. Army Corps of Engineers, Waterways Experiment Station, Vicksburg, MS.
- Kulhawy, F.H. and P.W. Mayne, 1990, *Manual on Estimating Soil Properties for Foundation Design*, Report EL-6800, Research Project No. 1493-6, Electric Power Research Institute (EPRI), Palo Alto, CA.
- Kumar, S., V.K. Puri, B.M. Das, B.C. Devkota, 2001, "Geotechnical Properties of Fly Ash and Lime-Fly Ash Stabilized Coal Mine Refuse," *Electronic Journal of Geotechnical Engineering*, Vol. 6 (2001).
- Ladd, C.C., 1991, "Stability Evaluation During Staged Construction," *Journal of Geotechnical Engineering*, ASCE, Vol. 117, No. 4, pp. 540-615.
- Ladd, C.C. and R. Foott, 1994, "A New Design Procedure for Stability of Soft Clay," *Journal of Geotechnical Engineering*, ASCE, Vol. 100, No. 7, pp. 763-786.
- Lambe, T.W., 1967, "The Stress Path Method" *Journal of the Soil Mechanics and Foundation Division*, ASCE, Vol. 93, No. 6, pp. 309-331.
- Lambe, T.W., 1951, *Soil Testing for Engineers*, John Wiley & Sons, New York, NY.
- Lambe, T.W. and A.M. Marr, 1979, "Stress Path Method: Second Edition," *Journal of Geotechnical Engineering*, ASCE, Vol. 105, No. 6, pp. 727-738.
- * LaVassar, J.M., 2000, "Two Decades of Dam Safety Office Experience in Applying a Risk Based Approach to Mine Impoundments," *Proceedings, Tailings Dams 2000*, Las Vegas, Association of State Dam Safety Officials (ASDSO), Lexington, KY.
- Legget, R.F., 1962, *Geology and Engineering*, McGraw-Hill, New York, NY.
- Leonards, G.A., ed., 1962, *Foundation Engineering*, McGraw-Hill, New York, NY.
- Leonards, G.A. and J. Narain, 1963, "Flexibility of Clay and Cracking of Dams," *Journal of the Soil Mechanics and Foundations Division*, ASCE, Vol. 89, No. SM2, pp. 47-98.
- Leps, T. M., 1973, "Flow Through Rockfill," *Embankment-Dam Engineering: Casagrande Volume*, R.C. Hirschfeld and S.J. Poulos, eds., John Wiley & Sons, New York, NY, pp. 87-107.
- Linsley, R.K. and J.B. Franzini, 1972, *Water Resources Engineering*, McGraw-Hill, New York, NY.
- Linsley, R.K., M.A. Kohler and J.L. Paulhus, 1982, *Hydrology for Engineers*, 3rd Ed., McGraw-Hill, New York, NY.

- Lo, K-Y and Y.N. Lee, 1990, "Hydraulic Fracture in Earth- and Rock-fill Dams," *Canadian Geotechnical Journal*, Vol. 27, No. 4, pp. 496-506.
- Londe, P., 1970, "La Fissuration des Noyaux," *Proceedings, 10th International Conference on Large Dams*, Vol. VI, pp. 384-387.
- Love, E. R., W.H. Hammack, J. Sams, G. Veloski and T. Ackman, 2005, "Case History – Using Airborne Thermal Infrared Imagery and Helicopter EM Conductivity to Locate Mine Pools and Discharges in the Kettle Creek Watershed, North-Central Pennsylvania," *Geophysics*, Vol. 70, No. 6, pp. B73–B81.
- Lowe, J. and L. Karafiath, 1960, "Effect of Anisotropic Consolidation on the Undrained Strength of Compacted Clays," *Proceedings of the ASCE Research Conference on Shear Strength on Cohesive Soils*, New York, American Society of Civil Engineers, Reston, VA, pp. 837-858.
- Luetlich, S.M., J.P. Giroud and R.C. Bachus, 1992, "Geotextile Filter Design Guide," *Journal of Geotextiles and Geomembranes*, Vol. 11, Nos. 4-6, pp. 355-370.
- Lunne, T., P.K. Robertson and J.J.M. Powell, 1997, *Cone Penetration Testing in Geotechnical Practice*, Spon Press, London, UK.
- Luo, Y., S.S. Peng and H.J. Chen, 1996, "Identification of Factors Affecting Horizontal Displacement in Subsidence Process," *Proceedings, 15th International Conference on Ground Control in Mining*, Colorado School of Mines, Golden, CO, pp. 155-165.
- Mackey, R.E. and G.R. Koerner, 1999, "Biological Clogging of Geotextile Filters – A Five Year Study," *Proceedings, Geosynthetics '99*, Boston, Geosynthetics Research Institute, Folsom, PA, Vol. 2, pp. 783-798.
- * Magnuson, M.O. and E.C. Baker, 1974, "State-of-the-Art in Extinguishing Refuse Pile Fires," *Proceedings, First Symposium on Mine and Preparation Plant Refuse Disposal*, Louisville, KY, National Coal Association, Washington, DC, pp. 165-182.
- Mainali, G., 2006, *Monitoring of Tailings Dams with Geophysical Methods*, Licentiate Thesis, Lulea University of Technology, Department of Civil and Environmental Engineering, Division of Applied Geophysics, Lulea, Sweden.
- Makdisi, F.I. and H.B. Seed, 1978, "Simplified Procedure for Estimating Dam and Embankment Earthquake-Induced Deformations," *Journal of the Geotechnical Engineering Division, ASCE*, Vol. 104, No. GT7, pp. 849-867.
- * Makdisi, F.I. and H.B. Seed, 1977, *A Simplified Procedure for Computing Maximum Crest Acceleration and Natural Period for Embankments*, Report No. UCB/EERC-77/19, Earthquake Engineering Research Center, University of California, Berkeley, CA.
- Malvick, E.J., B.L. Kutter, R.W. Boulanger and R. Kulasingam, 2006, "Shear Localization Due to Liquefaction-Induced Void-Redistribution in a Layered Infinite Slope," *Journal of Geotechnical and Geoenvironmental Engineering, ASCE*, Vol. 132, No. 10, pp. 1293-1303.
- Maneval, D.R., 1969, "Recent Advances in Extinguishment of Burning Coal Refuse Banks for Air Pollution Reduction," *Proceedings, Symposium on Pollution Control in Fuel Combustion, Processing and Mining*, Minneapolis, MN, pp. 27-41.
- Marcuson, W.F., III, M.E. Hynes and A.G. Franklin, 1992, "Seismic Stability and Permanent Deformation Analyses: The Last Twenty-Five Years," *Proceedings, Stability Performance of Slopes and Embankments II*, R.B. Seed and R.W. Boulanger, eds., University of California, Berkeley, American Society of Civil Engineers (ASCE), Reston, VA, pp. 552-592.
- * Mark, C., 2006, "The Evolution of Intelligent Coal Pillar Design: 1981-2006," *Proceedings, 25th International Conference on Ground Control in Mining*, University of West Virginia, Morgantown, WV, pp. 325-334.

- * Marks, B.D. and B.A. Tschantz, 2002, *A Technical Manual on the Effects of Tree and Woody Vegetation Root Penetrations on the Safety of Earthen Dams*, ASDSO/FEMA Workshop, compiled by Marks Enterprises of NC, PLLC, Arden, NC.
- * Marshall Miller & Associates (MM&A), 2006, *An Analysis of In-Seam Seismic Reflection Techniques to Identify and Locate Abandoned Underground Mine Voids in Advance of Mining*, Geophysical Void Detection Demonstration Project, prepared for MSHA by MM&A and Virginia Tech, Bluefield, WV.
- Martin, J.F., 1974, "Quality of Effluents from Coal Refuse Piles," *Proceedings, First Symposium on Mine and Preparation Plant Refuse Disposal*, Louisville, KY, National Coal Association, Washington, DC, pp. 26-37.
- * Martin, T.E. and M. P. Davies, 2000, "Development and Review of Surveillance Programs for Tailings Dams," *Proceedings, Tailings Dams 2000*, Las Vegas, Association of State Dam Safety Officials (ASDSO), Lexington, KY, pp. 367-380.
- Mayne, P.W. and F.H. Kulhawy, 1982, " K_o -OCR Relationships in Soil," *Journal of Geotechnical Engineering*, ASCE, Vol. 108, No. GT6, pp. 851-872.
- * Mayne, P.W., B.R. Christopher and J. DeJong, 2002, *Subsurface Investigations (Geotechnical Site Characterization)*, FHWA-NHI-01-031, U.S. Department of Transportation, Federal Highway Administration (FHWA), National Highway Institute, Washington, DC.
- Maynard, S.T., 1978, *Practical Riprap Design*, Miscellaneous Paper H-78-7, U.S. Department of the Army, Corps of Engineers, Waterways Experiment Station, Vicksburg, MS.
- * McCook, D.K., 2006, "Pipes in Drain Systems – Are They a Necessary Evil?" *2006 Annual Conference Proceedings*, Boston, Association of State Dam Safety Officials (ASDSO), Lexington, KY.
- * McCook, D.K., 2002, "Things Your Mother Never Told You about Earth Dam Design," *2002 Annual Conference Proceedings*, Tampa, Association of State Dam Safety Officials (ASDSO), Lexington, KY.
- * McCook, D.K., and J.R. Talbot, 2008, "A Comprehensive Sand and Gravel Filter Design Approach with Examples, Flow Charts, and Step by Step Process," *2008 Annual Conference Proceedings*, Indian Wells, Association of State Dam Safety Officials (ASDSO), Lexington, KY.
- McCutcheon, H.P., 1983, *Liquefaction and Cyclic Mobility of Coal Refuse Material*, M.S. Thesis, Carnegie Mellon University, Pittsburgh, PA.
- McGrath, T.J. and R.J. Hoopes, 1998, "Bedding Factors and E' Values for Buried Pipe Installations Backfilled with Air-Modified CLSM," *The Design and Application of Controlled Low-Strength Materials (Flowable Fill)*, ASTM STP 1331-EB, A.K. Howard and J.L. Hitch, eds., American Society for Testing and Materials (ASTM), West Conshohocken, PA.
- * McGuire, R.K., 1978, *FRISK: Computer Program for Seismic Risk Analysis Using Faults as Earthquake Sources*, Open File Report 78-1007, U.S. Department of the Interior, U.S. Geological Survey, Denver, CO.
- * McGuire, R.K., 1976, *FORTTRAN Computer Program for Seismic Risk Analysis*, Open-File Report 76-67, U.S. Department of the Interior, U.S. Geological Survey, Denver, CO.
- McGuire, R.K., 1974, *Seismic Structural Response Risk Analysis Incorporating Peak Response Regressions on Earthquake Magnitude and Distance*, Research Report R74-51, Massachusetts Institute of Technology, Department of Civil Engineering, Cambridge, MA.
- McKenna, G., 2006, "Rules of Thumb for Geotechnical Instrumentation Costs," *Geotechnical News*, BiTech Publishers, Richmond, BC, Canada, Vol. 24, No. 2, pp. 46-47.
- McLaren, R.J. and A.M. DiGioia, Jr., 1987, "The Typical Engineering Properties of Fly Ash," *Proceedings, Geotechnical Practice for Waste Disposal '87*, R.D. Woods, ed., New York, American Society of Civil Engineers (ASCE), Reston, VA, pp. 683-697.

- * McNay, L.M., 1971, *Coal Refuse Fires, an Environmental Hazard*, Report No. BM-IC-8515, U.S. Department of the Interior, Bureau of Mines, Washington, DC.
- McNeill, J.D., 1990, "Use of Electromagnetic Methods for Groundwater Studies," *Investigations in Geophysics No. 5: Geotechnical and Environmental Geophysics*, S.H. Ward, ed., Society of Exploration Geophysicists, Tulsa, OK, Vol. I, pp. 191–218.
- * Meek, F.A., 1994, "Evaluation of Acid Prevention Techniques Used in Surface Mining," *Proceedings, International Land Reclamation and Mine Drainage Conference*, SP 06B-94, U.S. Department of the Interior, Bureau of Mines, Pittsburgh, PA, pp. 41-48.
- Mesri, G. and M.E.M. Abdel-Ghaffar, 1993, "Cohesion Intercept in Effective Stress Stability Analysis," *Journal of Geotechnical Engineering*, Vol. 119, No. 8, pp. 1229-1249.
- Michael, P. and M. Superfesky, 2007, "Excess Spoil Minimization and Fill Stability," *Proceedings, 2007 Annual Meeting*, Society for Mining, Metallurgy and Exploration (SME), Denver, CO.
- * Michael, P., R. Murguia and L. Kosareo, 2005, *The Flowability of Impounded Coal Refuse: A Review of Recent Work and Current Ideas in the Engineering Profession*, OSM Final Report, U.S. Department of the Interior, Office of Surface Mining, Washington, DC.
- Michalek, S.J., G.H. Gardner and K.K. Wu, 1996, *Accidental Releases of Slurry and Water from Coal Impoundments through Abandoned Underground Mines*, U.S. Department of Labor, MSHA, Safety and Health Technology Center, Pittsburgh, PA.
- Mihok, E.A. and C.E. Chamberlain, 1968, "Factors in Neutralizing Acid Mine Water with Limestone," *Proceedings, 2nd Symposium on Coal Mine Drainage Research*, Mellon Institute, Pittsburgh, PA, pp. 165-173.
- Mikkelsen, P.E., 2002, "Cement-Bentonite Grout Backfill for Borehole Instruments," *Geotechnical News*, Vol. 20, No. 4, pp. 38-42.
- * Mine Safety and Health Administration (MSHA), 2008, *Final Reports on Geophysical Void Detection Demonstration Projects*, U.S. Department of Labor, MSHA, Arlington, VA.
- * Mine Safety and Health Administration (MSHA), 2007, *MSHA Coal Mine Impoundment Inspection and Plan Review Handbook*, Handbook No. PH07-01, U.S. Department of Labor, MSHA, Arlington, VA.
- * Mine Safety and Health Administration (MSHA), 2003, *Report to Congress: Responses to Recommendations in the National Research Council's Report, "Coal Waste Impoundments: Risks, Responses and Alternatives"*, U.S. Department of Labor, MSHA, Arlington, VA.
- * Mine Safety and Health Administration (MSHA), 1999, *Haul Road Inspection Handbook*, PH99-I-4, U.S. Department of Labor, MSHA, Arlington, VA.
- Mine Safety and Health Administration (MSHA), 1993, *Coal Impoundment Inspection Procedures Handbook*, PH89-V-4, U.S. Department of Labor, MSHA, Arlington, VA.
- Mine Safety and Health Administration (MSHA), 1983, *Design Guidelines for Coal Refuse Piles and Water, Sediment, or Slurry Impoundments, and Impounding Structures*, Amendment to Informational Report 1109, Technical Support Center, Denver, CO and Pittsburgh, PA.
- * Mining Enforcement and Safety Administration (MESA), 1975, *Engineering and Design Manual, Coal Refuse Disposal Facilities*, U.S. Department of the Interior, MESA, Washington, DC.
- Mishra, G.C. and A.K. Singh, 2005, "Seepage through a Levee," *International Journal of Geomechanics*, ASCE, Vol. 5, No. 1, pp. 74-79.
- Mitchell, R.J., 1983, *Earth Structures Engineering*, Allen and Unwin, Boston MA.
- Molinda, G.M., C. Mark and D. Debasis, 2001, "Using the Coal Mine Roof Rating (CMRR) to Assess Roof Stability in U.S. Coal Mines," *Journal of Mines, Metals & Fuels*, Vol. 49, No. 8-9, pp. 314-321.

- Morgenstern, N.R. and V.E. Price, 1965, "The Analysis of the Stability of General Slip Surfaces," *Géotechnique*, Vol. 15, No. 1, pp. 79-93.
- Morris, P.H. and D.J. Williams, 2000, "A Revision of Blight's Model of Field Vane Testing," *Canadian Geotechnical Journal*, Vol. 37, No. 5, 1089-1098.
- Moser, A.P., 2001, *Buried Pipe Design*, 2nd Ed., McGraw-Hill, New York, NY.
- * Myers, J.W., J.J. Pfeiffer, E.M. Murphy and F.E. Griffith, 1966, *Ignition and Control of Burning of Coal Mine Refuse*, Report No. BM-RI-6758, U.S. Department of the Interior, Bureau of Mines, Washington, DC.
- Naesgaard, E., P.M. Byrne, M. Seid-Karbasi and S.S. Park, 2005, "Modeling Flow Liquefaction, Its Mitigation, and Comparison with Centrifuge Tests," *Proceedings, Geotechnical Earthquake Engineering Satellite Conference*, Osaka, Japan.
- National Academy of Sciences, 1975, *Underground Disposal of Coal Mine Wastes*, Washington, DC.
- National Coal Board (NCB), 1975, *Subsidence Engineers' Handbook*, Mining Department of the NCB, London, UK.
- National Coal Board (NCB), 1972, *Review of Research on Properties of Spoil Tip Materials*, NCB, London, UK.
- National Coal Board (NCB), 1970, "Spoil Heaps and Lagoons," *Technical Handbook*, NCB, London, UK.
- National Research Council (NRC), 2002, *Coal Waste Impoundments: Risks, Responses, and Alternatives*, Committee on Coal Waste Impoundments, Committee on Earth Resources, Board on Earth Sciences and Resources, Division on Earth and Life Studies, National Academy Press, Washington, DC.
- National Stone, Sand & Gravel Association (NSSGA – formerly National Stone Association), 1989, *Quarried Stone for Erosion and Sediment Control*, Alexandria, VA.
- National Weather Service (NWS), 2006a, *NOAA Atlas 14, Precipitation Atlas of the United States, Volume 1, The Semi-Arid Southwest*, U.S. Department of Commerce, National Oceanic and Atmospheric Administration, NWS (available on-line only).
- National Weather Service (NWS), 2006b, *NOAA Atlas 14, Precipitation Atlas of the United States, Volume 2, The Ohio River Basin and Surrounding States*, U.S. Department of Commerce, National Oceanic and Atmospheric Administration, NWS (available on-line only).
- * National Weather Service (NWS), 1999, *Hydrometeorological Report No. 59, Probable Maximum Precipitation for California*, U.S. Department of Commerce, National Oceanic and Atmospheric Administration, NWS, Washington, DC.
- * National Weather Service (NWS), 1998, *Hydrometeorological Report No. 58, Probable Maximum Precipitation for California – Calculation Procedures*, U.S. Department of Commerce, National Oceanic and Atmospheric Administration, NWS, Washington, DC.
- * National Weather Service (NWS), 1994, *Hydrometeorological Report No. 57, Probable Maximum Precipitation – Pacific Northwest States*, U.S. Department of Commerce, National Oceanic and Atmospheric Administration, NWS, Washington, DC.
- * National Weather Service (NWS), 1988, *Hydrometeorological Report No. 55A, Probable Maximum Precipitation Estimates, United States between the Continental Divide and the 105th Meridian*, U.S. Department of Commerce, National Oceanic and Atmospheric Administration, NWS, Washington, DC.
- * National Weather Service (NWS), 1986, *Hydrometeorological Report No. 56, Probable Maximum Precipitation Estimates with Areal Distribution for Tennessee River Drainages Less than 3000 Square Miles in Area*, U.S. Department of Commerce, National Oceanic and Atmospheric Administration, NWS, Washington, DC.
- * National Weather Service (NWS), 1982, *Hydrometeorological Report No. 52, Application of Probable Maximum Precipitation Estimates, United States East of the 105th Meridian*, U.S. Department of Commerce, National Oceanic and Atmospheric Administration, NWS, Washington, DC.

- * National Weather Service (NWS), 1980, *Hydrometeorological Report No. 53, Seasonal Variation of 10-Square-Mile Probable Maximum Precipitation Estimates, United States East of the 105th Meridian*, U.S. Department of Commerce, National Oceanic and Atmospheric Administration, NWS, Washington, DC.
- * National Weather Service (NWS), 1978, *Hydrometeorological Report No. 51, Probable Maximum Precipitation Estimates, United States East of the 105th Meridian*, U.S. Department of Commerce, National Oceanic and Atmospheric Administration, NWS, Washington, DC.
- * National Weather Service (NWS), 1977, *Hydrometeorological Report No. 49, Probable Maximum Precipitation Estimates, Colorado River and Great Basin Drainages*, U.S. Department of Commerce, National Oceanic and Atmospheric Administration, NWS, Washington, DC.
- National Weather Service (NWS), 1973, *NOAA Atlas 2, Precipitation Frequency Atlas of the Western United States*, U.S. Department of Commerce, National Oceanic and Atmospheric Administration, NWS, Washington, DC.
- * National Weather Service (NWS), 1965, *Technical Paper No. 52, Two- to 10-Day Precipitation for Return Periods from 1 to 100 Years in Alaska*, U.S. Department of Commerce, National Oceanic and Atmospheric Administration, NWS, Washington, DC.
- * National Weather Service (NWS), 1964, *Technical Paper No. 49, Two- to 10-Day Precipitation for Return Periods from 2 to 100 Years for the Contiguous United States*, U.S. Department of Commerce, National Oceanic and Atmospheric Administration, NWS, Washington, DC.
- * National Weather Service (NWS), 1963, *Technical Paper No. 47, Probable Maximum Precipitation and Rainfall Frequency Data for Alaska for Areas to 400 Square Miles, Durations to 24 Hours, and Return Periods from 1 to 100 Years*, U.S. Department of Commerce, National Oceanic and Atmospheric Administration, NWS, Washington, DC.
- * Natural Resources Conservation Service (NRCS), 2007a, *National Engineering Handbook, Chapter 7: Hydrologic Soil Groups*, 210-VI-NEH, U.S. Department of Agriculture, NRCS, Washington, DC.
- * Natural Resources Conservation Service (NRCS), 2007b, *National Engineering Handbook, Chapter 45: Filter Diaphragms*, 210-VI-NEH, U.S. Department of Agriculture, NRCS, Washington, DC.
- * Natural Resources Conservation Service (NRCS), 2007c, *NRCS Fillable Form Template*, U.S. Department of Agriculture, NRCS, Washington, DC.
- * Natural Resources Conservation Service, 2005a, *National Engineering Handbook, Chapter 52: Structural Design of Flexible Conduits*, 210-VI-NEH, U.S. Department of Agriculture, NRCS, Washington, DC.
- * Natural Resources Conservation Service (NRCS), 2005b, *Earth Dams and Reservoirs*, TR-60, 210-VI-TR60, U.S. Department of Agriculture, NRCS, Washington, DC.
- * Natural Resources Conservation Service (NRCS), 2004a, *National Engineering Handbook, Chapter 9: Hydrologic Soil Cover Complexes*, 210-VI-NEH, U.S. Department of Agriculture, NRCS, Washington, DC.
- * Natural Resources Conservation Service (NRCS), 2004b, *National Engineering Handbook, Chapter 10: Estimation of Direct Runoff from Storm Rainfall*, 210-VI-NEH, U.S. Department of Agriculture, NRCS, Washington, DC.
- * Natural Resources Conservation Service (NRCS), 2004c, *National Engineering Handbook, Chapter 11: Snowmelt*, 210-VI-NEH, U.S. Department of Agriculture, NRCS, Washington, DC.
- * Natural Resources Conservation Service (NRCS), 2002, *Pond*, Conservation Practice Standard No. 378, U.S. Department of Agriculture, NRCS, Washington, DC.
- * Natural Resources Conservation Service (NRCS), 1994, *National Engineering Handbook, Chapter 26: Gradation Design of Sand and Gravel Filters*, U.S. Department of Agriculture, NRCS, Washington, DC.

- * Natural Resources Conservation Service (NRCS), 1986, *Urban Hydrology for Small Watersheds*, TR-55, 210-VI-TR55, U.S. Department of Agriculture, NRCS, Washington, DC.
- * Newman, D.A., 2003, "Rock Mechanics and the Analysis of Underground Mine Stability Adjacent to Coal Refuse Impoundments," *Proceedings, 22nd International Conference on Ground Control in Mining*, West Virginia University, Morgantown, WV.
- Newmark, N.M., 1965, "Effects of Earthquakes on Dams and Embankments," *Géotechnique*, Vol. 15, No. 2, pp. 139-160.
- Nicholas, A.K. and R.J. Hutnik, 1971, *Ectomycorrhizal Establishment and Seedling Response on Various Treated Deep-Mine Coal Refuse*, Special Report SR-89, School of Forest Resources, Pennsylvania State University, University Park, PA.
- * Nicholls, H.R., C.F. Johnson and W.I. Duvall, 1971, *Blasting Vibrations and Their Effects on Structures*, Bulletin 656, U.S. Department of the Interior, Bureau of Mines, Washington, DC.
- * Nieto, A.S., 1979, "Evaluation of Damage Potential to Earth Dams by Subsurface Coal Mining at Rend Lake, Illinois," *Proceedings, Geotechnics of Mining: 10th Ohio River Valley Seminar*, Lexington, KY, pp. 9-18.
- Nilson, A.H., D. Darwin and C.W. Dolan, 2002, *Design of Concrete Structures*, 13th Ed., McGraw-Hill, New York, NY.
- Nuttli, O.W., 1973, "Seismic Wave Attenuation and Magnitude Relations for Eastern North America," *Journal of Geophysical Research*, Vol. 78, No. 5, pp. 876-885.
- O'Brien, J.J., J.A. Havers and F.W. Stubbs, eds., 1996, *Standard Handbook of Heavy Construction*, 3rd Ed., McGraw-Hill, New York, NY.
- O'Connor, K.M. and C.H. Dowding, 1999, *GeoMeasurements by Pulsing TDR Cables and Probes*, CRC Press, Boca Raton, FL.
- Oglesby, C.H. and R.G. Hicks, 1982, *Highway Engineering*, 4th Ed., John Wiley & Sons, New York, NY.
- * Ohio Department of Transportation (ODOT), 2006, *Geotechnical Bulletin GB3: Rock Cut Slope and Catchment Design*, Division of Production Management, Office of Geotechnical Design, Columbus, OH.
- * Olin, D.A. and J.B. Atkins, 1988, *Estimating Flood Hydrographs and Volumes for Alabama Streams*, Water Resources Investigation Report 88-4041, U.S. Department of the Interior, U.S. Geological Survey, Water Resources Division, Tuscaloosa, AL.
- Olsen, R.S. and J.K. Mitchell, 1995, "CPT Stress Normalization and Prediction of Soil Classification," *Proceedings of the International Symposium on Cone Penetration Testing, CPT '95*, Linköping, Sweden, Swedish Geotechnical Society, Vol. 2, pp. 257-262.
- Olson, S.M. and T.D. Stark, 2003, "Yield Strength Ratio and Liquefaction Analysis of Slopes and Embankments," *Journal of Geotechnical and Geoenvironmental Engineering*, ASCE, Vol. 129, No. 8, pp. 727-737.
- Olson, S.M. and T.D. Stark, 2002, "Liquefied Strength Ratio from Liquefaction Flow Failure Case Histories," *Canadian Geotechnical Journal*, National Research Council of Canada, Vol. 39, pp. 629-647.
- Owens, H.L., 2008, personal communication.
- Owens, H.L., 1987, *MSHA Report of Investigation, Impoundment Principal Spillway Pipe Failure*, Montcoal Preparation Plant (ID No. 46-03430), Peabody Coal Company, Raleigh County, WV.
- Owens, H.L., 1977, *MESA Memorandum on Failure of the Fine Coal Refuse Impoundment (ID No. 1211WV40009-02)*, Pond Fork Preparation Plant, Island Creek Coal Company, Boone County, WV.
- Packer, P.E. and E.F. Aldon, 1978, "Revegetation Techniques for Dry Regions," *Reclamation of Drastically Disturbed Land*, F.W. Schaller and P. Sutton, eds., American Society of Agronomy, Madison, WI, pp. 425-450.

Page, A.L., R.H. Miller and D.R. Keeney, eds., 1982, *Methods of Soil Analysis, Part 2: Chemical and Microbiological Properties*, Agronomy Monograph No. 9, 2nd Ed., American Society of Agronomy and Soil Science of America, Madison, WI.

Pariseau, W.G., 2006, *Design Analysis in Rock Mechanics*, CRC Press, Boca Raton, FL.

Pariseau, W.G., 1975, "Limit Design of Mine Pillars under Uncertainty," *Proceedings, 16th U.S. Symposium on Rock Mechanics*, University of Minnesota, Minneapolis, MN, pp. 287-301.

Park, R. and T. Paulay, 1975, *Reinforced Concrete Structures*, John Wiley & Sons, New York, NY.

Patterson, R.J. and K.D. Ferguson, 1994, "The Gibraltar North Project Assessing Acid Rock Drainage," *Proceedings, 3rd International Conference on the Abatement of Acidic Drainage*, Pittsburgh, PA, U.S. Bureau of Mines Special Publication SP 06B-94, Vol. 2, pp. 12-21.

*Pearson, M.L., T. Preber and P.J. Conroy, 1981, *Outcrop Barrier Design Guidelines for Appalachian Coal Mines*, Open File Report 134-81, U.S. Department of the Interior, Bureau of Mines, Washington, DC.

Peck, R.B., 1972, "Observations and Instrumentation: Some Elementary Considerations," *Highway Focus*, U.S. Department of Transportation, Federal Highway Administration, Vol. 4, No. 2, pp. 1-5. Reprinted in *Judgment in Geotechnical Engineering: The Professional Legacy of Ralph B. Peck*, 1984, J. Dunnycliff and D.U. Deere, eds., John Wiley & Sons, New York, NY, pp. 128-130.

Pelton, F., 2000, *Guidelines for Instrumentation and Measurement for Monitoring Dam Performance*, 0-7844-0531-X, ASCE Task Committee on Instrumentation and Monitoring Dam Performance, American Society of Civil Engineers (ASCE), Reston, VA.

Peng, S.S. and H.S. Chiang, 1984, *Longwall Mining*, John Wiley & Sons, New York, NY.

Peng, S.S. and Y. Luo, 1993, "A New Method for Designing Support Area to Protect Surface Structures over Underground Coal Mining Areas," *Transactions, AIME-SME*, Vol. 294, pp. 1927-1932.

* Pennsylvania Department of Environmental Protection (PADEP), 2000, *Erosion and Sediment Pollution Control Program Manual*, Document No. 363-2134-008, PADEP, Office of Water Management, Bureau of Watershed Management, Division of Waterways, Wetlands and Erosion Control, Harrisburg, PA.

Pennsylvania Department of Transportation (PennDOT), 2007, *Specifications Publication 408/2007*, Commonwealth of Pennsylvania, PennDOT, Harrisburg, PA.

* Pennsylvania State University (PSU), 2006, *An In-Seam Seismic (ISS) Method Based Mine Void Detection Technique*, Final Report for Phase I, prepared for MSHA by Maochen Ge, PSU, University Park, PA.

Performance Pipe, 2003, *The Performance Pipe Engineering Manual*, Performance Pipe Division of Chevron Phillips Chemical Company, LP, Plano, TX.

* Perin, R.J., 2000, "Foundation Treatment of Stress Relief Fractures 'Hillseams' in a Tailings Embankment Cutoff Trench," *Proceedings, Tailings Dams 2000*, Las Vegas, ASDSO/USCOLD, pp. 197-209.

Perlea, V.G., M.E. Rothford and D.C. Serafini, 2009, "Use of Seismic Deformation Analysis in Remediation Design," *Proceedings, 29th Annual USSD Conference*, Nashville, United States Society on Dams, Denver, CO.

Phelps, L.B., W.B. Wells and L.W. Saperstein, 1981, "An Analysis of Surface Coal Mine Spoil Bulk Density," Society of Mining Engineering Annual Meeting, SME Preprint No. 81-53, Chicago, IL.

Poulos, S.J., 1988, "Chapter 9 – Liquefaction and Related Phenomena," *Advanced Dam Engineering for Design, Construction, and Rehabilitation*, R.B. Jansen, ed., Van Nostrand Reinhold, New York, NY.

Poulos, S.J., 1981, "The Steady State of Deformation," *Journal of the Geotechnical Engineering Division*, ASCE, Vol. 107, No. GT5, pp. 553-562.

- Poulos, H.G. and E.H. Davis, 1974, *Elastic Solutions for Soil and Rock Mechanics*, John Wiley & Sons, New York, NY.
- Poulos, S.J., G. Castro and J.W. France, 1985, "Liquefaction Evaluation Procedure," *Journal of the Geotechnical Engineering Division*, ASCE, Vol. 111, No. GT6, pp. 772-792.
- Pratt, H.K., R.C. McMordie and R.M. Dundas, 1972, "Foundations and Abutment - Bennett and Mica Dams," *Journal of the Soil Mechanics and Foundations Division*, ASCE, Vol. 98, SM10, pp. 1053-1072.
- Price, W.A., K.A. Morin and N.M. Hutt, 1997, "Guidelines for the Prediction of Acid Rock Drainage and Metal Leaching for Mines in British Columbia: Part II, Recommended Procedures for Static and Kinetic Tests," *Proceedings, 4th International Conference on Acid Rock Drainage*, Vancouver, BC, Canada, American Society of Surface Mining and Reclamation, Vol. I, pp. 15-30.
- Qiu, Y.J., and D.C. Sego, 2001, "Laboratory Properties of Mine Tailings," *Canadian Geotechnical Journal*, Vol. 38, No. 1, pp. 183-190.
- Quaranta, J.D., L.D. Banta, and J.A. Altobello, 2008, "Remote Monitoring of a High Hazard Coal Waste Impoundment in Mountainous Terrain Case Study," *Proceedings, Tailings and Mine Waste '08*, Vail, CO, pp. 125-136.
- Reddi, L.N., 2003, *Seepage in Soils – Principles and Applications*, John Wiley & Sons, Hoboken, NJ.
- Rellensmann, O. and E. Wagner, 1957, "The Effect on Railways of the Ground Movements Due to Mining," *Proceedings, First European Congress on Ground Movement*, University of Leeds, Leeds, UK, pp. 74-82.
- Rich, D.H. and K.R. Hutchinson, 1990, "Neutralization and Stabilization of Combined Refuse Using Lime Kiln Dust at High Power Mountain," *Proceedings, 1990 Mining and Reclamation Conference and Exhibition*, Charleston, WV, Vol. I, pp. 55-60.
- Richter, C., 1958, *Elementary Seismology*, W.H. Freeman and Co., San Francisco, CA.
- Rico, M., G. Benito and A. Diez-Herrero, 2008, Floods from Tailings Dam Failures, *Journal of Hazardous Materials*, Vol. 152, No. 2, pp. 846-852.
- * Rixner, J.J., S.R. Kraemer and A.D. Smith, 1986, *Prefabricated Vertical Drains, Vol. I, Engineering Guidelines*, Report No. FHWA/RD-86/168, Office of Engineering and Highway Operations Research and Development, Federal Highway Administration, McLean, VA.
- * Robbins, C.H., 1986, *Techniques for Simulating Flood Hydrographs and Estimating Flood Volumes for Ungaged Basins in Tennessee*, Water Resources Investigation Report 86-4192, U.S. Department of the Interior, U.S. Geological Survey, Water Resources Division, Nashville, TN.
- Robertson, P.K., 2008, discussion of paper, "Liquefaction Potential of Silts from CPTu," *Canadian Geotechnical Journal*, Vol. 45, pp. 140-141.
- Robertson, P.K., 2004, "Evaluating Soil Liquefaction and Post-Earthquake Deformations Using the CPT," *Proceedings of ISC-2 on Geotechnical and Geophysical Site Characterization*, Porto, Portugal, V. Fonseca and P.W. Mayne, eds., Millpress, Rotterdam, Vol. 1, pp. 233-252.
- Robertson, P.K., 1994, "Suggested Terminology for Liquefaction," *Proceedings of the 47th Canadian Geotechnical Conference*, Halifax, NS, Canadian Geotechnical Society, Alliston, ON, Canada, pp. 277-286.
- Robertson, P.K. and R.G. Campanella, 1983, "Interpretation of Cone Penetration Tests: Part I - Sands; Part II - Clays," *Canadian Geotechnical Journal*, Vol. 20, No. 4, pp. 719-745.
- Robertson, P.K. and C.E. Wride, 1998, "Evaluating Cyclic Liquefaction Potential Using the Cone Penetration Test," *Canadian Geotechnical Journal*, Vol. 35, No. 3, pp. 442-459.
- Rupert, G.B. and G.B. Clark, 1977, "Criteria for the Proximity of Surface Blasting to Underground Coal Mines," *Proceedings, 18th U.S. Symposium on Rock Mechanics*, Colorado School of Mines, Keystone, CO, pp. 3C3-1 to 3C3-10.

- * Rusnak, J. and C. Mark, 2000, "Using the Point Load Test to Determine the Uniaxial Compressive Strength of Coal Measure Rock," *Proceedings, 19th International Conference on Ground Control in Mining*, S.S. Peng and C. Mark, eds., West Virginia University, Morgantown, WV, pp. 362-371.
- Rutledge, P.C. and J.P. Gould, 1973, "Movements of Articulated Conduits under Earth Dams on Compressible Foundations," *Embankment-Dam Engineering: Casagrande Volume*, R.C. Hirschfeld and S.J. Poulos, eds., John Wiley & Sons, New York, NY, pp. 209-237.
- * Sabatini, P.J., R.C. Bachus, P.W. Mayne, J.A. Schneider and T.E. Zettler, 2002, *Geotechnical Engineering Circular No. 5: Evaluation of Soil and Rock Properties*, DTFH61-94-C-00099, U.S. Department of Transportation, Federal Highway Administration (FHWA), Office of Bridge Technology, Washington, DC.
- Saikia, C.K. and P.G. Somerville, 1997, "Simulated Hard-Rock Motions in Saint Louis, Missouri, from Large New Madrid Earthquakes ($M_w \geq 6.5$)," *Bulletin of the Seismological Society of America*, Vol. 87, No. 1, pp. 123-139.
- * Sames, G.P. and N.N. Moebs, 1992, *Roof Control of Stress-Relief Jointing near Outcrops in Central Appalachian Drift Mines*, Information Circular 9313, U.S. Department of the Interior, Bureau of Mines, Pittsburgh, PA.
- * Sames, G.P. and N.N. Moebs, 1989, *Hillseam Geology and Roof Instability Near Outcrop in Eastern Kentucky Drift Mines*, Report of Investigations 9267, U.S. Department of the Interior, Bureau of Mines, Pittsburgh, PA.
- Sarma, S.K., 1973, "Stability Analysis of Embankments and Slopes," *Géotechnique*, Vol. 23, No. 3, pp. 423-433.
- * Savy, J.B., W. Foxall, N.A. Abrahamson and D.L. Bernreuter, 2002, *Guidance for Performing Probabilistic Seismic Hazard Analysis for a Nuclear Plant Site: Example Application to the Southeastern United States*, NUREG/CR-6607 (UCRL-ID-133494), Office of Nuclear Regulatory Research, U.S. Nuclear Regulatory Commission (USNRC), Washington, DC.
- Saxena, S.K., D.E. Lourie and J.S. Rao, 1984, "Compaction Criteria for Eastern Coal Waste Embankments," *Journal of the Geotechnical Engineering Division*, ASCE, Vol. 110, No. GT2, pp. 262-284.
- * Schaefer, M.G., 1992, *Dam Safety Guidelines - Technical Note 1: Dam Break Inundation Analysis and Downstream Hazard Classification*, Publication 92-55E, Washington State Department of Ecology, Olympia, WA.
- * Schnabel, P.B., J. Lysmer and H.B. Seed, 1972, *SHAKE: A Computer Program for Earthquake Response Analysis of Horizontally Layered Sites*, Report No. EERC 72-12, University of California, Berkeley, CA.
- * Schubert, C.E., W.J. Johnson and B.W. Hassinger, 1982, *Improved Resource Characterization for Coal Mining (Geophysics and Drilling Technology)*, Contract No. USDOE AC22-80PC30114, U.S. Department of Energy, Office of Coal Mining, Washington, DC.
- Schwartz, D.P. and K.J. Coppersmith, 1986, "Seismic Hazards: New Trends in Analysis Using Geologic Data," *Studies in Geophysics-Active Tectonics*, National Academy Press, Washington, DC, pp. 215-230.
- Scovazzo, V.A., 2008, personal communication regarding experience with angle of draw.
- * Scovazzo, V.A., 1995, "Comparison of Empirical, Analytical, and Numerical Methods of Pillar Design and the Development of a Site Specific Pillar Formula," *Proceedings, 14th International Conference on Ground Control in Mining*, West Virginia University, Morgantown, WV, pp. 116-123.
- Seed, H.B., 1987, "Design Problems in Soil Liquefaction," *Journal of Geotechnical Engineering*, ASCE, Vol. 113, No. 8, pp. 827-845.
- Seed, H.B., 1979, "Soil Liquefaction and Cyclic Mobility Evaluation for Level Ground During Earthquakes," *Journal of the Geotechnical Engineering Division*, ASCE, Vol. 105, No. GT2, pp. 201-255.

- Seed, R.B. and L.F. Harder, Jr., 1990, "SPT-Based Analysis of Cyclic Pore Pressure Generation and Undrained Residual Strength," *Proceedings of the H. Bolton Seed Memorial Symposium*, Vol. 2, University of California, Berkeley, CA, BiTech Publishers, Richmond, BC, Canada, pp. 351-376.
- Seed, H.B. and I.M. Idriss, 1982, "Ground Motions and Soil Liquefaction During Earthquakes," Earthquake Engineering Research Institute, Berkeley, CA.
- Seed, H.B. and I.M. Idriss, 1971, Simplified Procedure for Evaluating Soil Liquefaction Potential, *Journal of the Geotechnical Engineering Division*, ASCE, Vol. 97, No. 9, pp. 1249-1273.
- * Seed, R.B., K.O. Cetin, R.E.S. Moss, A.M. Kammerer, J. Wu, J.M. Pestina, M.F. Riemer, R.B. Sancio, J.D. Bray, R.E. Kayen and A. Faris, 2003, *Recent Advances in Soil Liquefaction Engineering: A Unified and Consistent Framework*, Report No. EERC 2003-06, 26th Annual ASCE Los Angeles Geotechnical Spring Seminar, Long Beach CA.
- Serafim, J.L. and J.P. Pereira, 1983, "Considerations on the Geomechanical Classification of Bieniawski," *Proceedings, International Symposium on Engineering Geology and Underground Construction*, Lisbon, Portugal, Theme II, Vol. 1, pp. II.33-II.42.
- Shackelford, R., 2000, "Underground Surveying – A Primer in Coal Mine Surveying and Mapping," *Point of Beginning Electronic Magazine*, Sept. 29, 2000 issue.
- Sherard, J.L., 1973, "Embankment Dam Cracking," *Embankment-Dam Engineering: Casagrande Volume*, R.C. Hirschfeld and S.J. Poulos, eds., John Wiley & Sons, New York, NY, pp. 272-353.
- Sherard, J.L. and L.P. Dunnigan, 1985, "Filters and Leakage Control in Embankment Dams," *Proceedings, Symposium on Seepage and Leakage from Dams and Impoundments*, Denver, American Society of Civil Engineers (ASCE), Reston, VA, pp. 1-31.
- Sherard, J.L., L.P. Dunnigan, R.S. Decker and E.F. Steele, 1976, "Pinhole Test for Identifying Dispersive Clays," *Journal of the Geotechnical Engineering Division*, ASCE, Vol. 102, No. GT1, pp. 69-85.
- Sherard, J.L., R.J. Woodward, S.F. Gizienski, and W.A. Clevenger, 1963, *Earth and Earth-Rock Dams: Engineering Problems of Design and Construction*, John Wiley & Sons New York, NY.
- Shoup, D., 1992, "Protecting Geotechnical Sensors and Cable from Lightning Damage," *Sensors in the Real World*, Slope Indicator Company.
- Singh, M.M., 1992, "Mine Subsidence," *SME Mining Engineering Handbook*, 2nd Ed., H. Hartman, ed., Society for Mining, Metallurgy, & Exploration (SME), Littleton, CO, pp. 938-971.
- Singh, M.M., 1978, "Experience with Subsidence Due to Mining," *Proceedings, International Conference on Evaluation and Prediction of Subsidence*, New York, American Society of Civil Engineers (ASCE), Reston, VA, pp. 92-112.
- * Singh, M.M. and F.S. Kendorski, 1981, "Strata Disturbance Prediction for Mining Beneath Surface Water and Waste Impoundments," *Proceedings, 1st Conference on Ground Control in Mining*, West Virginia University, Morgantown, WV, pp. 76-89.
- * Sirles, P.C., 2006, *Use of Geophysics for Transportation Projects: A Synthesis of Highway Practice*, NCHRP Synthesis 357, Transportation Research Board, National Cooperative Highway Research Program, Washington, DC.
- * Siskind, D.E., M.S. Stagg, J.W. Kopp and C.H. Dowding, 1980, *Structure Response and Damage Produced by Ground Vibration from Surface Mine Blasting*, Report of Investigations 8507, U.S. Department of the Interior, Bureau of Mines, Pittsburgh, PA.
- * Skelly and Loy, 1977, *Guidelines for Mining near Surface Waters*, Open File Report 29-77, U.S. Department of the Interior, Bureau of Mines, Washington, DC.
- * Skousen, J.G., A.W. Rose, G. Geidel, R. Foreman, R. Evans, W.W. Hellier and members of the Avoidance and Remediation Working Group of the Acid Drainage Technology Initiative, 1998,

Handbook of Technologies for Avoidance and Remediation of Acid Mine Drainage, National Mine Land Reclamation Center, West Virginia University, Morgantown, WV.

Skousen, J.G., J.C. Sencindiver and R.M. Smith, 1987, *A Review of Procedures for Surface Mining and Reclamation in Areas with Acid-Producing Materials*, West Virginia University Energy and Water Research Center Publication EWRC 871, Morgantown, WV.

Slemmons, D.B. and C.M. Depolo, 1986, "Evaluation of Active Faulting and Associated Hazards," *Studies in Geophysics-Active Tectonics*, National Academy Press, Washington, DC, pp. 45-62.

Smith, R.M., A.A. Sobek, T. Arkle, Jr., J.C. Sencindiver and J.R. Freeman, 1976, *Extensive Overburden Potentials for Soil and Water Quality*, EPA 600/1-76-184, U.S. Department of the Environment, U.S. Environmental Protection Agency, Washington, DC.

Smith, R.M., W.E. Grube, T. Arkle, Jr. and A. Sobek, 1974, *Mine Spoil Potentials for Soil and Water Quality*, EPA 670/2-74-070, U.S. Department of the Environment, U.S. Environmental Protection Agency, Washington, DC.

* Smith, S.A. and D.M. Hosler, 2006, "Current Research in Dam Drain Clogging and Its Prevention," *Proceedings, 2006 ASDSO Annual Conference*, Boston, Association of State Dam Safety Officials, Lexington, KY.

Snow, R.E., J.L. Olson and W. Schultz, 2000, "Slurry Impoundment Internal Drain Design and Construction," *Proceedings of the 7th Conference on Tailings and Mine Waste '00*, Fort Collins, CO, pp. 65-73.

Sobel, P., 1994, *Revised Livermore Seismic Hazard Estimates for Sixty-Nine Nuclear Power Plant Sites East of the Rocky Mountains*, NUREG 1488, Division of Engineering, Office of Nuclear Reactor Regulation, U.S. Nuclear Regulatory Commission (USNRC), Washington, DC.

Somerville, P.G., N.F. Collins, N.A. Abrahamson, R.W. Graves and C.K. Saikia, 2001, *Ground Motion Attenuation Relations for the Central and Eastern United States*, Final Report to U.S. Geological Survey, URS Group, Inc., Pasadena, CA.

Song, S-H., Y. Song and B-D. Kwon, 2005, "Application of Hydrogeological and Geophysical Methods to Delineate Leakage Pathways in an Earth Fill Dam," *Exploration Geophysics*, Vol. 36, No. 1, pp. 92-96.

Sowers, G.F. and G.B. Sowers, 1970, *Introductory Soil Mechanics and Foundations*, 4th Ed., Macmillan Publishing Company, New York, NY.

Spencer, E., 1967, "A Method of Analysis of the Stability of Embankments Assuming Parallel Inter-slice Forces," *Géotechnique*, Vol. 17, No. 1, pp. 11-26.

Stewart, B.M. and G. Robinson, 1994, *MSHA Accident Investigation Report, Non-Injury Inundation Report, Martin County Coal Corporation, 1-C Mine (ID No. 15-03752)*, Martin County, KY.

* Stewart, B.M. and L.A. Atkins, 1983, *Physical Property Data on Coarse Anthracite Waste*, Report of Investigations 8782, U.S. Department of the Interior, Bureau of Mines, Pittsburgh, PA.

* Stewart, B.M. and L.A. Atkins, 1982, *Engineering Properties of Combined Coarse and Fine Coal Wastes*, Report of Investigations 8623, U.S. Department of the Interior, Bureau of Mines, Pittsburgh, PA.

* Stewart, B.R., W.L. Daniels, L.W. Zelazny and M.L. Jackson, 2001, "Evaluation of Leachates from Coal Refuse Blended with Fly Ash at Different Rates," *Journal of Environmental Quality*, Vol. 30, No. 5, pp. 1382-1391.

* Stewart, B.R., W.L. Daniels, and M.L. Jackson, 1997, "Evaluation of Leachate Quality from the Co-Disposal of Coal Fly Ash and Coal Refuse," *Journal of Environmental Quality*, Vol. 26, No. 5, pp. 1412-1424.

Szymanski, M.B., 1999, *Evaluation of Safety of Tailings Dams*, BiTech Publishers, Richmond, BC, Canada.

- * Talbot, J.R., S.J. Poulos, and R.C. Hirschfeld, 2000, "Remediation of Seepage Problems through Cutoff or Reduction of Flow and through Collection and Control of Seepage Including the Use of Geosynthetics," *The National Dam Safety Program, Research Needs Workshop: Seepage through Embankment Dams*, White Paper No. 5, Attachment 8, Denver, U.S. Department of Homeland Security, Federal Emergency Management Agency (FEMA), Washington, DC.
- Talwani, P. and W.T. Schaeffer, 2001, "Recurrence Rates of Large Earthquakes in the South Carolina Coastal Plain Based on Paleoliquefaction Data," *Journal of Geophysical Research*, Vol. 106, No. B4, pp. 6621-6642.
- Terzaghi, K. and R.B. Peck, 1967, *Soil Mechanics in Engineering Practice*, 2nd Ed., John Wiley & Sons, New York, NY.
- Terzaghi, K., R.B. Peck and G. Mesri, 1996, *Soil Mechanics in Engineering Practice*, 3rd Ed., Wiley-Interscience, New York, NY.
- * Thacker, B.K., 2000, "Perimeter Embankments to Increase Capacity, Mitigate Subsidence Impacts, and Abandon Coal Refuse Disposal Impoundments," *Proceedings, Tailing Dams 2000*, Las Vegas, ASDSO/USCOLD, pp. 143-154.
- Thacker, B.K., 1997, "Liquefaction Mitigation Procedures for Coal Refuse Dams Built by the Modified Upstream Method," *Proceedings, XXVIII Ohio River Valley Soils Seminar*, Lexington, KY.
- Thacker, B.K., C.R. Ulrich, J.C. Athanaskes and G. Smith, 1988, "Evaluation of Coal Refuse Impoundment Built by the Upstream Method," *Geotechnical Special Publication No. 21, Hydraulic Fill Structures*, American Society of Civil Engineers (ASCE), New York, NY, pp. 730-749.
- Thiers, G.R. and H.B. Seed, 1968, "Cyclic Stress-Strain Characteristics of Clays," *Journal of the Soil Mechanics and Foundations Division*, ASCE, Vol. 94, No. SM2, pp. 555-569.
- Timoshenko, S. and S. Woinowsky-Krieger, 1959, *Theory of Plates and Shells*, 2nd Ed., McGraw-Hill, New York, NY.
- Toro, G.R. and R.K. McGuire, 1987, "An Investigation into Earthquake Ground Motion Characteristics in Eastern North America," *Bulletin of the Seismological Society of America*, Vol. 77, No. 2, pp. 468-489.
- Toro, G.R., N.A. Abrahamson and J.F. Schneider, 1997, "Model of Strong Ground Motions from Earthquakes in Central and Eastern North America: Best Estimates and Uncertainties," *Seismological Research Letters*, Vol. 68, No. 1, pp. 41-57.
- Tuttle, M.P., E.S. Schweig, J.D. Sims, R.H. Lafferty, L.W. Wolf and M.L. Haynes, 2002, "The Earthquake Potential of the New Madrid Seismic Zone," *Bulletin of the Seismological Society of America*, Vol. 92, No. 6, pp. 2080-2089.
- Ullrich, C.R., B.R. Thacker and N.R. Roberts, 1991, "Dynamic Properties of Fine-Grained Coal Refuse," *Proceedings, Second International Conference on Recent Advances in Geotechnical Earthquake Engineering and Soil Dynamics*, St. Louis, MO, pp. 393-397.
- University of British Columbia-Geophysical Inversion Facility (UBC-GIF), 2005, "Three-Dimensional Modeling of Self-Potentials Caused by Seepage Flows," *Investigation of Geophysical Methods for Assessing Seepage and Internal Erosion in Embankment Dams*, CEA Technologies, Inc. Project No. T992700-0205, Montreal, QC, Canada.
- University of California, 2007a, Pacific Earthquake Engineering Research Center: NGA Database, Coyote Lake – Gilroy #6, 230 (CDMG Station 57383), August 6, 1979, M = 5.7. (<http://peer.berkeley.edu/index.html>)
- University of California, 2007b, Pacific Earthquake Engineering Research Center: NGA Database, Saguenay – W. Chicoutime Nord (Site 16 T), November 25, 1988, M = 5.9. (<http://peer.berkeley.edu/index.html>)

University of California, 2007c, Pacific Earthquake Engineering Research Center: NGA Database, Whittier Narrows Station: 24399, Mt. Wilson – CIT Seismic Station October 1, 1987, M = 5.99. (<http://peer.berkeley.edu/index.html>).

- * U.S. Army Corps of Engineers (USACE), 2008, *Hydrologic Modeling System, HEC-HMS, Users Manual, Version 3.3*, CDP-74A, U.S. Department of the Army, USACE, Washington, DC.
- * U.S. Army Corps of Engineers (USACE), 2004, *Cathodic Protection for Civil Works Structures*, EM 1110-2-2704, U.S. Department of the Army, USACE, Washington, DC.
- * U.S. Army Corps of Engineers (USACE), 2003, *Engineering and Design – Slope Stability*, EM 1110-2-1902, U.S. Department of the Army, USACE, Washington, DC.
- U.S. Army Corps of Engineers (USACE), 2002, *Coastal Engineering Manual – Part II*, EM 1110-2-1100, U.S. Department of the Army, USACE, Washington, DC.
- * U.S. Army Corps of Engineers (USACE), 2000, *Hydrologic Modeling System HEC-HMS: Technical Reference Manual*, Report No. CPD-74B, U.S. Department of the Army, USACE, Hydrologic Engineering Center, Davis, CA.
- * U.S. Army Corps of Engineers (USACE), 1999, *Engineering and Design – Response Spectra and Seismic Analysis for Concrete Hydraulic Structures*, Engineer Manual 1110-2-6050, U.S. Department of the Army, USACE, Washington, DC.
- * U.S. Army Corps of Engineers (USACE), 1998a, *Engineering and Design – Conduits, Culverts and Pipes*, EM 1110-2-2902, U.S. Department of the Army, USACE, Washington, DC.
- * U.S. Army Corps of Engineers (USACE), 1998b, *HEC-1 Flood Hydrograph Package: User's Manual*, U.S. Department of the Army, USACE, Hydrologic Engineering Center, Davis, CA.
- * U.S. Army Corps of Engineers (USACE), 1995a, *Geophysical Exploration for Engineering and Environmental Investigations*, EM 1110-1-1802, U.S. Department of the Army, USACE, Washington, DC.
- * U.S. Army Corps of Engineers (USACE), 1995b, *Construction Control for Earth and Rock-Fill Dams*, EM 1110-2-1911, U.S. Department of the Army, USACE, Washington, DC.
- * U.S. Army Corps of Engineers (USACE), 1995c, *Instrumentation of Embankment Dams and Levees*, EM 1110-2-1908, U.S. Department of the Army, USACE, Washington, DC.
- * U.S. Army Corps of Engineers (USACE), 1994, *Hydraulic Design of Flood Control Channels*, EM 1110-2-1601, U.S. Department of the Army, USACE, Washington, DC.
- * U.S. Army Corps of Engineers (USACE), 1993, *Engineering and Design – Seepage Analysis and Control for Dams*, EM 1110-2-1901, U.S. Department of the Army, USACE, Washington, DC.
- * U.S. Army Corps of Engineers (USACE), 1990a, *Construction with Large Stone*, EM 1110-2-2302, U.S. Department of the Army, USACE, Washington, DC.
- * U.S. Army Corps of Engineers (USACE), 1990b, (Revised April 1992), *Hydraulic Design of Spillways*, EM 1110-2-1603, U.S. Department of the Army, USACE, Washington, DC.
- * U.S. Army Corps of Engineers (USACE), 1986, *Laboratory Soils Testing*, EM-1110-2-1906, U.S. Department of the Army, USACE, Washington, DC.
- U.S. Army Corps of Engineers (USACE), 1985, *Electrical Protection – Cathodic Protection*, EM-1110-2-1922, U.S. Department of the Army, USACE, Washington, DC.
- * U.S. Army Corps of Engineers (USACE), 1984a, *Grouting Technology*, EM 1110-2-3506, U.S. Department of the Army, USACE, Washington, DC.
- * U.S. Army Corps of Engineers (USACE), 1984b, *User's Manual, HMR52, Probable Maximum Storm (Eastern United States)*, U.S. Department of the Army, USACE, Hydrologic Engineering Center, Davis, CA.

References

- * U.S. Army Corps of Engineers (USACE), 1980, *Hydraulic Design of Reservoir Outlets*, EM-1110-2-1602, U.S. Department of the Army, USACE, Washington, DC.
- * U.S. Bureau of Reclamation (USBR), 2007a, *Design Standards No. 13 for Embankment Dams: Chapter 5, Protective Filters*, U.S. Department of the Interior, USBR, Technical Services Center, Denver, CO.
- * U.S. Bureau of Reclamation (USBR), 2007b, *Uplift and Crack Flow Resulting from High Velocity Discharges over Open Offset Joints: Laboratory Studies*, Report DSO-07-07, USBR, Technical Service Center, Denver, CO.
- * U.S. Bureau of Reclamation (USBR), 2001, *Water Measurement Manual*, 3rd Ed., Revised Reprint, U.S. Government Printing Office, Washington, DC.
- * U.S. Bureau of Reclamation (USBR), 1998, *Earth Manual*, 3rd Ed., U.S. Department of the Interior, USBR, Earth Sciences and Research Laboratory, Technical Services Center, Denver, CO.
- * U.S. Bureau of Reclamation (USBR), 1992a, *Design Standards No. 13 – Embankment Dams, Chapter 2, Embankment Design*, U.S. Department of the Interior, USBR, Technical Services Center, Denver, CO.
- U.S. Bureau of Reclamation (USBR), 1992b, *Concrete Manual, Part 2: A Manual for the Control of Concrete Construction*, 9th Ed., Water Resources Technical Publication, U.S. Department of the Interior, Technical Services Center, USBR, Denver, CO.
- * U.S. Bureau of Reclamation (USBR), 1991, *Design Standards No. 13 – Embankment Dams, Chapter 10, Embankment Construction*, U.S. Department of the Interior, USBR, Technical Services Center, Denver, CO.
- * U.S. Bureau of Reclamation (USBR), 1990, *Cavitation in Chutes and Spillways*, Engineering Monograph No. 42, U.S. Department of the Interior, USBR, Denver, CO.
- * U.S. Bureau of Reclamation (USBR), 1988, *Downstream Hazard Classification Guidelines*, ACER Technical Memorandum No. 11, U.S. Department of the Interior, USBR, Denver, CO.
- * U.S. Bureau of Reclamation (USBR), 1987a, *Design of Small Dams*, 3rd Ed., U.S. Department of the Interior, USBR, Washington, DC.
- * U.S. Bureau of Reclamation (USBR), 1989, *Design Standards No. 13 - Embankment Dams, Chapter 13, Seismic Design and Analysis*, U.S. Department of the Interior, USBR, Technical Services Center, Denver, CO.
- * U.S. Bureau of Reclamation (USBR), 1984, *Design Standards No. 13 – Embankment Dams, Chapter 3, Foundation Treatment*, U.S. Department of the Interior, USBR, Technical Services Center, Denver, CO.
- U.S. Bureau of Reclamation (USBR), 1973, *Design of Small Dams*, 2nd Ed., U.S. Department of the Interior, USBR, Washington, DC.
- U.S. Committee on Large Dams (USCOLD), 1999, *Updated Guidelines for Selecting Seismic Parameters for Dam Projects*, USCOLD Committee on Earthquakes, USCOLD, Denver, CO.
- U.S. Department of Agriculture (USDA), 1985, *Dimensioning of Filter-Drainage Diaphragms for Conduits According to TR-60*, Technical Note, Series No. 709, USDA, Soil Conservation Service, South National Technical Center, Forth Worth, TX (see NRCS 2007b for current criteria).
- * U.S. Department of Agriculture (USDA), 1978, *National Engineering Handbook, Section 8, Engineering Geology*, NEH-8 (now Part 631-Geology), USDA, Soil Conservation Service, Washington, DC.
- * U.S. Department of Agriculture (USDA), 1973a, *Flow Net Construction and Use*, Soil Mechanics Note No. 5, 210-VI-SMN-5, USDA, Soil Conservation Service, Washington, DC.
- * U.S. Department of Agriculture (USDA), 1973b, *A Method for Estimating Volume and Rate of Runoff in Small Watersheds*, SCS-TP-149, USDA, Soil Conservation Service, Washington, DC.
- U.S. Department of Agriculture (USDA), 1972, *National Engineering Handbook, Section 4, Hydrology*, NEH-4 (now Part 630-Hydrology), USDA, Soil Conservation Service, Washington, DC.

- * U.S. Department of Agriculture (USDA), 1969, *Computation of Joint Extensibility Requirements*, Technical Release No. 18, 210-VI-TR-18, USDA, Soil Conservation Service, Washington, DC.
- U.S. Department of Agriculture (USDA), 1968, *Hydraulics of Broad-Crested Spillways*, Technical Release 39, USDA, Soil Conservation Service, Washington, DC.
- * U.S. Department of Agriculture (USDA), 1958, *Structural Design of Underground Conduits*, Technical Release No. 5, 210-VI-TR-5, USDA, Soil Conservation Service, Washington, DC.
- U.S. Department of Agriculture (USDA), 1956, *National Engineering Handbook - Chapter 5: Hydraulics*, 210-VI-NEH, USDA, Soil Conservation Service, Washington, DC.
- U.S. Department of Energy (USDOE), 1996, *Guidelines for the Use of Probabilistic Seismic Hazard Curves at Department of Energy Sites for Department of Energy Facilities*, DOE-STD-1024-92, originally published December 1992, incorporating Change Notice #1, January 1996, Washington, DC.
- * U.S. Environmental Protection Agency (USEPA), 2000, *Coal Remining Best Management Practices Guidance Manual*, EPA 821-R-00-007, U.S. Department of the Environment, USEPA, Office of Science and Technology, Washington, DC.
- * U.S. Environmental Protection Agency (USEPA), 1993, *Use of Airborne, Surface, and Borehole Geophysical Techniques at Contaminated Sites – A Reference Guide*, EPA/625/R-92/007, U.S. Department of the Environment, USEPA, Office of Research and Development, Washington, DC.
- U.S. Environmental Protection Agency (USEPA), 1983, *Neutralization of Acid Mine Drainage: Design Manual*, USEPA-600/2-83-001, U.S. Department of the Environment, USEPA, Cincinnati, OH.
- * U.S. Geological Survey (USGS), 2005, *Comparison of Peak Discharge and Runoff Characteristic Estimates from the Rational Method to Field Observations for Small Basins in Central Virginia*, Scientific Investigation Report 2005-5254, U.S. Department of the Interior, Geological Survey, Denver, CO.
- * U.S. Geological Survey (USGS), 1989, *Guide for Selecting Manning's Roughness Coefficients for Natural Channels and Flood Plains*, Water Supply Paper 2339, USGS, Denver, CO.
- U.S. Nuclear Regulatory Commission (USNRC), 1997, *Recommendations for Probabilistic Seismic Hazard Analysis: Guidance on Uncertainty and Use of Experts*, NUREG/CR-6372, Panel on Seismic Hazard Evaluation, National Research Council, Washington, DC.
- U.S. Nuclear Regulatory Commission (USNRC), 1993, *Revised Livermore Seismic Hazard Estimates for 69 Nuclear Power Plant Sites East of the Rocky Mountains*, NUREG-1488, USNRC, Washington, DC.
- * U.S. Society on Dams (USSD), 2007, "Strength of Materials for Embankment Dams," USSD Committee on Materials for Embankment Dams, Denver, CO.
- Virginia Department of Mine Land Reclamation (VA DMLR), 2006, "Slurry Injection Permit Requirements," presented at Underground Injection Workshop sponsored by the Office of Surface Mining (OSM), National Mine Land Reclamation Center, University of West Virginia, Morgantown, WV.
- Van Aller, H.W., 2004, "Piping, Seepage Conduits and Dam Failure," presented at ASDSO South-eastern Regional Technical Seminar, Jackson, MS.
- * Van Aller, H.W., 1998, "Filter Diaphragm Design Considerations: A Collection of Useful References and Design Guidelines," originally presented at 1990 ASDSO Mid-Atlantic Regional Technical Seminar, Baltimore, MD.
- van der Veen, R., 2002, "Automatic Data Acquisition Systems and Databases," *Geotechnical News*, BiTech Publishers, Richmond, BC, Canada, Vol. 20, No. 1, pp. 24-28.
- van Zyl, D. and A.M. Robertson, 1980, "Subsurface Drainage of Tailings Impoundments: Some Design, Construction and Management Considerations," *Proceedings, Symposium on Uranium Mill Tailings Management*, Fort Collins, CO, pp. 153-177.

- Veneziano, D. and J. Van Dyck, 1985, "Analysis of Earthquake Catalogues for Incompleteness and Recurrence Rates: Seismic Hazard Methodology for Nuclear Facilities in the Eastern United States," Project No. P101-29, Vol. 2, Appendix A-6, Electric Power Research Institute (EPRI), Palo Alto, CA.
- * Vick, S.G., 2000, "Tailings Dam Safety - Implications for the Dam Safety Community," *Proceedings, Tailings Dams 2000*, Las Vegas, ASDSO/USCOLD, pp. 1-19.
- * Vogel, W.G., 1987, *A Manual for Training Reclamation Inspectors in the Fundamentals of Soils and Revegetation*, U.S. Department of the Interior, Office of Surface Mining and Enforcement, Washington, DC.
- Von Thun, J.L., 1996, "Risk Assessment of Nambe Falls Dam," *Geotechnical Special Publication No. 58*, C.D. Shackelford, P.P. Nelson and M.J.S. Roth, eds., American Society of Civil Engineers (ASCE), Reston, VA, pp. 604-635.
- * Wahl, T.L., 1998, *Prediction of Embankment Dam Breach Parameters: A Literature Review and Needs Assessment*, Dam Safety Research Report DSO-98-004, U.S. Department of the Interior, Bureau of Reclamation, Dam Safety Office, Denver, CO.
- Wald, D.J., V. Quitoriano, T.H. Heaton and H. Kanamori, 1999, "Relationships between Peak Ground Acceleration, Peak Ground Velocity and Modified Mercalli Intensity in California," *Earthquake Spectra*, Vol. 15, No. 3, pp. 557-564.
- * Walker, J.S., 1993, *State-of-the-Art Techniques for Backfilling Abandoned Mine Voids*, Information Circular No. 9359, U.S. Department of the Interior, Bureau of Mines, Pittsburgh, PA.
- Wang, Z., E.W. Woolery, B. Shi and J.D. Kiefer, 2003, "Communicating with Uncertainty: A Critical Issue with Probabilistic Seismic Hazard Analysis," *EOS Transactions*, American Geophysical Union (AGU), Vol. 84, No. 46, pp. 501, 506, 508.
- Ward, S.H., ed., 1990, *Investigations in Geophysics, No. 5: Geotechnical and Environmental Geophysics*, Vols. I-III, Society of Exploration Geophysicists, Tulsa, OK.
- Wartman, J., J.D. Bray and R.B. Seed, 2004, "Inclined Plane Studies of the Newmark Sliding Block Procedure," *Journal of Geotechnical and Geoenvironmental Engineering*, ASCE, Vol. 129, No. 8, pp. 673-684.
- Watkins, R.K. and L.R. Anderson, 1999, *Structural Mechanics of Buried Pipes*, CRC Press, New York, NY.
- Weaver, K.D. and D.A. Bruce, 2007, *Dam Foundation Grouting*, ASCE Press, Reston, VA.
- Wells, D.L. and K.J. Coppersmith, 1994, "New Empirical Relationships among Magnitude, Rupture Length, Rupture Width, Rupture Area, and Surface Displacement," *Bulletin of the Seismological Society of America*, Vol. 84, No. 4, pp. 974-1002.
- West Virginia Department of Transportation (WVDOT), 1999, *Materials Procedure, Nuclear Density Test by the Roller Pass Method*, MP 700.00.24.
- West Virginia Surface Mine Drainage Task Force, 1979, "Suggested Guidelines for Methods of Operation," *Surface Mining of Areas with Potentially Acid-Producing Materials*, *Proceedings, West Virginia Surface Mine Drainage Task Force Symposium*, West Virginia Department of Natural Resources, Charleston, WV.
- West Virginia Water Research Institute, 2005, *Guidance Document for Coal Waste Impoundment Facilities & Coal Waste Impoundment Inspection Form*, West Virginia University, Morgantown, WV.
- Wetzel, K.L. and S.A. Hoffman, 1989, *Distribution of Water-Quality Characteristics that May Indicate the Presence of Acid Mine Drainage in the Eastern Coal Province of the United States*, Hydrologic Investigations Atlas HA-705, U.S. Department of the Interior, Geological Survey, Denver, CO.

Whittaker, B.N. and D.J. Reddish, 1989, *Subsidence: Occurrence, Prediction and Control*, Elsevier, Amsterdam, Netherlands.

* Wightman, W.E., F. Jalinoos, P. Sirles and K. Hanna, 2003, *Application of Geophysical Methods to Highway Related Problems*, Contract No. DTFH68-02-P-00083, Federal Highway Administration, Central Federal Lands Highway Division, Lakewood, CO.

Wildeman, T.R., J.J. Gusek, and G.A. Brodie, 1993, *Wetland Design for Mining Operations*, Bitech Publishers, Richmond, BC, Canada.

Wilkins, J.K., 1956, "Flow of Water through Rockfill and Its Application to the Design of Dams," *Proceedings, 2nd Australia-New Zealand Conference on Soil Mechanics and Foundation Engineering*, International Society for Soil Mechanics and Foundation Engineering, University of Canterbury, Christchurch, NZ.

Wilson, A.H. and D.P. Ashwin, 1972, "Research into the Determination of Pillar Size: An Hypothesis Concerning Pillar Stability," *The Mining Engineer*, Vol. 131, No. 141, pp. 409-427.

Wilson, S.D. and L.R. Squier, 1969, "Earth and Rockfill Dams," *Proceedings, Seventh International Conference on Soil Mechanics and Foundation Engineering*, Mexico, pp. 137-223.

Wizniak, L. and R.J. Mitchell, 1987, "Crown Pillar Subsidence Prediction from Centrifuge Models," *Proceedings, International Symposium on Prediction and Performance in Geotechnical Engineering*, Calgary, Alberta, Canada, R.C. Joshi and F.J. Griffiths, eds., pp. 387-395.

Workhorse Technologies, 2006, personal communication.

Workman, J.L. and P.C. Satchwell, 1987, *Blasting as an AML Reclamation Method*, 2 Vols., U.S. Department of the Interior, Office of Surface Mining, Washington, DC.

Wride, C.E., E.C. McRoberts and P.K. Robertson, 1999, "Reconsideration of Case Histories for Estimating Undrained Shear Strength in Sandy Soils," *Canadian Geotechnical Journal*, Vol. 36, No. 5, pp. 907-933.

Wu, K.K., H.L. Owens and J.W. Fredland, 2003, "MSHA's Review of Impoundment Plans," 2003 *SME Annual Meeting, Preprint 03-099*, Cincinnati, Society for Mining Metallurgy and Exploration (SME), Littleton, CO.

Wyllie, D.C. and C.W. Mah, 2004, *Rock Slope Engineering*, Spon Press, New York, NY.

* Wyrick, G.G. and J.W. Borchers, 1981, *Hydrologic Effects of Stress-Relief Fracturing in an Appalachian Valley*, Water Supply Paper 2177, U.S. Department of the Interior, U.S. Geological Survey, Reston, VA.

Yearly, D.C., 2003, "Sustainable Development for the Global Mining and Metals Industry," *Mining Engineering*, Vol. 55, No. 8, pp. 45-48.

Yoshimine, M., P.K. Robertson, and C.E. Wride, 1999, "Undrained Shear Strength of Clean Sands to Trigger Flow Liquefaction," *Canadian Geotechnical Journal*, Vol. 36, No. 5, pp. 891-906.

Youd, T. L., I.M. Idriss, R.D. Andrus, I. Arango, G. Castro, J.T. Christian, R. Dobry, W.D.L. Finn, L.F. Harder, M.E. Hynes, K. Ishihara, J.P. Koester, S.S.C. Liao, W.F. Marcuson, G.R. Martin, J.K. Mitchell, Y. Moriwaki, M.S. Power, P.K. Robertson, R.B. Seed and K.H. Stokoe, 2001, "Liquefaction Resistance of Soils: Summary Report from the 1996 NCEER and 1998 NCEER/NSF Workshops on Evaluation of Liquefaction Resistance of Soils," *Journal of Geotechnical and Geoenvironmental Engineering*, ASCE, Vol. 127, No. 10, pp. 817-833.

Young, W.C. and R.G. Budynas, 2001, *Roark's Formulas for Stress and Strain*, 7th Ed., McGraw-Hill, New York, NY.

Zeng, X. and J.A. Goble, 2008, "Dynamic Properties of Coal Waste Refuse in a Tailings Dam," *Geotechnical Special Publication No. 181*, Geotechnical Earthquake Engineering and Soil Dynamics IV, D. Zeng, M.T. Manzari, and D.R. Hiltunen, eds., American Society of Civil Engineers (ASCE), Reston, VA.

References

Zeng, Y., J.G. Anderson, and G. Yu, 1994, "A Composite Source Model for Computing Realistic Synthetic Strong Ground Motions," *Geophysical Research Letters*, Vol. 21, No. 8, pp. 725-728.

Zhang, J., W. Wagner, A. Prakash, H. Mehl and S. Voight, 2004, "Detecting Coal Fires Using Remote Sensing Techniques," *International Journal of Remote Sensing*, Vol. 25, No. 16, pp. 3193-3220.