

CHAPTER 24

Buoys, Mooring Appendages, and Minor Structures

CONTENTS

	<i>Page</i>		<i>Page</i>		
24-1	DEFINITION.....	24- 2	24-6	BUOY VENTILATION.....	24-26
24-1-1	Buoys.....	24- 2	24-6-1	General.....	24-26
24-1-5	Mooring Appendages.....	24- 2	24-6-5	Vents.....	24-26
24-1-10	Minor Structures.....	24- 2	24-6-10	Conversion of Acetylene Buoys to Electric.....	24-27
24-2	CLASSIFICATION OF BUOYS.....	24- 3	24-7	BUOY MAINTENANCE.....	24-27
24-2-1	General.....	24- 3	24-7-1	Painting.....	24-27
24-2-5	Specific Types—Standard for Coast Guard Use.....	24- 3	24-7-2	Identifying Markings.....	24-27
24-2-10	Specific Types—Nonstandard.....	24- 3	24-7-5	Operational Maintenance.....	24-28
24-3	LIGHTED BUOYS.....	24- 3	24-7-10	Structural Repairs of Buoys.....	24-28
24-3-1	Purpose.....	24- 3	24-8	BUOY PROCUREMENT.....	24-30
24-3-5	General Design of Standard Types.....	24- 3	24-8-1	Requisitions.....	24-30
24-3-10	Characteristics of Construction.....	24- 4	24-8-5	Relief Buoys.....	24-30
24-3-15	Specific Standard Types for Exposed Locations.....	24- 4	24-8-10	Equipment on Term Contract.....	24-31
24-3-20	Specific Standard Types for Exposed and Semi-exposed Locations.....	24- 7	24-9	MOORING APPENDAGES.....	24-31
24-3-25	Specific Standard Types for Semi-exposed Locations.....	24- 9	24-9-1	Component Parts.....	24-31
24-3-30	Specific Standard Types for Protected Locations.....	24-11	24-9-5	Buoy Chain.....	24-31
24-3-35	Sound Apparatus—Lighted Buoys.....	24-12	24-9-10	Chain Bridles.....	24-32
24-3-40	Equipment and Appendages for Standard Lighted Buoys.....	24-14	24-9-15	Shackles.....	24-32
24-3-45	Specific Nonstandard Types.....	24-15	24-9-20	Swivels.....	24-33
24-3-50	Equipment and Appendages for Nonstandard Lighted Buoys.....	24-16	24-9-25	Sinkers.....	24-34
24-4	UNLIGHTED SOUND BUOYS.....	24-17	24-9-30	Ballast Balls.....	24-34
24-4-1	Purpose.....	24-17	24-9-35	Selecting Proper Appendages.....	24-35
24-4-5	Specific Standard Types.....	24-17	24-10	REFLEX SIGNALS.....	24-35
24-4-10	Specific Nonstandard Types.....	24-19	24-10-1	General.....	24-35
24-4-15	Mooring Appendages for all Unlighted Sound Buoys.....	24-20	24-11	MINOR STRUCTURES.....	24-35
24-5	UNLIGHTED BUOYS.....	24-20	24-11-1	General.....	24-35
24-5-1	General.....	24-20	24-11-5	Daybeacons.....	24-35
24-5-5	Specific Types.....	24-21	24-11-10	Single and Multiple Wooden Piling Lighted Structures.....	24-36
			24-11-15	Wood Skeleton Structures.....	24-48
			24-11-20	Steel Skeleton Structures.....	24-50
			24-11-25	Miscellaneous Types.....	24-51
			24-12	MAINTENANCE OF STRUCTURES.....	24-52
			24-12-1	General.....	24-52

ILLUSTRATIONS

Figure	Subject	Page	Figure	Subject	Page
24-1	10 x 39WE lighted buoy (whistle electric) ..	24-5	24-45	Cast iron ballast balls	24-34
24-2	9 x 32WE lighted buoy (whistle electric) ..	24-5	24-46	Single-pile daybeacon (8th District)	24-36
24-3	9 x 32BE lighted buoy (bell electric)	24-6	24-47	Minor light, single wood pile structure (8th District)	24-36
24-4	9 x 32GE lighted buoy (gong electric)	24-7	24-48	Minor light, single wood pile (8th District) ..	24-37
24-5	8 x 26E lighted buoy (electric)	24-7	24-49	Minor lights, three-pile-and-brace type (8th District)	24-38
24-6	8 x 26BE lighted buoy (bell electric)	24-8	24-50	Three-pile minor light (Intracoastal Water- way)	24-39
24-7	8 x 26GE lighted buoy (gong electric)	24-8	24-51	Three-pile minor light (5th District)	24-39
24-8	8 x 26WE lighted buoy (whistle electric) ..	24-9	24-52	Three-pile dolphin (8th District)	24-40
24-9	7FE lighted buoy (flat electric)	24-9	24-53	Three-pile dolphin (5th District)	24-40
24-10	6 x 20E lighted buoy (electric)	24-10	24-54	Five-pile dolphin (8th District)	24-41
24-11	6 x 20BE lighted buoy (bell electric)	24-10	24-55	Three-pile minor range light (8th district) ..	24-41
24-12	5FE lighted buoy (flat electric)	24-11	24-56	Nine-pile minor range light (8th district) ..	24-42
24-13	3½ FE lighted buoy (flat electric)	24-11	24-57	Rear range light (8th district)	24-43
24-14	Buoy whistle and valve (four ball)	24-12	24-58	Four-pile range structure, 42-foot focal plane (8th District)	24-44
24-15	Various sizes of buoy bells	24-12	24-59	Four-pile range structure, 52-foot focal plane (8th District)	24-45
24-16	36-inch gongs and stand	24-13	24-60	Four-pile range structure, 62-foot focal plane (8th District)	24-46
24-17	20-inch gongs and stand	24-13	24-61	Four-pile range structure with auxiliary passing light	24-47
24-18	Nonstandard lighted buoys	24-15	24-62	Wooden minor light structure on stone riprap	24-47
24-19	9 x 38WA and 6 x 20BA nonstandard lighted buoys	24-15	24-63	Wood skeleton minor light structure on stone riprap	24-48
24-20	Converted "C" and "B III" nonstandard lighted buoys	24-16	24-64	Wood skeleton minor light structure on con- crete-filled steel caisson	24-48
24-21	9B unlighted bell buoy	24-18	24-65	Wood skeleton minor light structure on con- crete-filled steel shell	24-49
24-22	9G unlighted gong buoy	24-18	24-66	Wood skeleton minor light structure on shore	24-49
24-23	8B unlighted bell buoy	24-18	24-67	Wood skeleton daybeacon on shore	24-50
24-24	8G unlighted gong buoy	24-18	24-68	Steel skeleton minor light structure on concrete foundation	24-50
24-25	7W unlighted whistle buoy	24-19	24-69	Iron-pile minor light structure on marine site	24-51
24-26	Buoy whistle and valve (two ball)	24-19	24-70	Steel skeleton minor light structure on concrete-filled steel shell on concrete foundation	24-51
24-27	Nonstandard unlighted bell and whistle buoys	24-20	24-71	Wooden battery box and lantern on con- crete-filled steel caisson (1st District) ..	24-51
24-28	Standard-type unlighted nun buoys	24-21	24-72	Close-up view of battery box and lantern (similar to fig. 24-71)	24-52
24-29	Standard-type unlighted can buoys	24-22	24-73	Minor light and daymark structure used on Mississippi River	24-53
24-30	Tall-type unlighted nun buoys	24-23			
24-31	Tall-type unlighted can buoys	24-23			
24-32	Special-type unlighted nun buoys	24-23			
24-33	Special-type unlighted can buoys	24-23			
24-34	River-type unlighted nun and can buoys ..	24-24			
24-35	Wooden spar buoys	24-25			
24-36	Table of moorings for spar buoys	24-25			
24-37	Buoy vent tube	24-27			
24-38	Interior vent connection	24-27			
24-39	Typical buoy vent piping arrangement	24-27			
24-39A	Nomenclature of parts of a lighted buoy ..	24-29			
24-40	Buoy chain	24-31			
24-41	Chain bridles	24-32			
24-42	Buoy shackles, split-key and rivet-pin types	24-33			
24-43	Buoy swivels	24-33			
24-44	Standard concrete sinkers	24-34			

24-1 DEFINITION

24-1-1 Buoys—

A. A buoy is a moored floating object which may be a metal cylindrical or conical float, or a wooden log (spar). In the case of lighted buoys, the cylindrical float is surmounted by a skeleton framework supporting the lantern. The distinctive shape and color of a buoy serves as a daymark, and in the case of a lighted buoy, the light indicates its presence and meaning at night.

B. Buoys have an advantage over fixed lights and daybeacons, in that they may be readily moored close to the navigational track of vessels so as to mark the side limits of channels, and may be easily relocated to meet varying conditions. Buoys are placed in positions where an aid to navigation is needed but where a fixed structure would be impractical to construct.

24-1-5 Mooring Appendages—

A. Standard mooring appendages consist of open-link buoy chain, chain bridles, swivels, shackles, cast iron ballast balls, and concrete or cast iron sinkers. On some inland waterways, galvanized wire is used in lieu of chain on small buoys.

24-1-10 Minor Structures—

A. A minor structure is any structure either on shore or on a marine site erected for the purpose of supporting a minor acetylene, electric, or oil light, or daymark. It may be a skeleton wood or steel tower, a single or multiple wood or iron piling, or a concrete or rock structure. The types in use are varied and are often built to fit peculiar local conditions, therefore, this chapter will be confined to description of a few of the more prevalent types in use.

B. A minor structure serves the same purpose as a buoy for marking shoals, limits of channels, etc., and in addition, serves to mark the axis of a channel when two structures are placed so as to form a range. The marine sites, however, are restricted to locations of shallow depth.

C. Minor structures are considerably less expensive than buoys to establish and maintain.

24-2 CLASSIFICATION OF BUOYS

24-2-1 General—

A. Lighted, lighted sound, and unlighted sound buoys are classified according to:

- (1) Diameter.
- (2) Over-all length.
- (3) Sound equipment.
 - (a) W=Whistle.
 - (b) B=Bell.
 - (c) G=Gong.
 - (d) H=Horn.
- (4) Light source.
 - (a) E=Electric (FE=Flat Electric).
 - (b) A=Acetylene.
- (5) RB=Radiobeacon.
- (6) For example: An 8 x 26-WE means a lighted buoy, 8 feet in diameter, 26 feet over-all length, a whistle for sound equipment, and powered by electricity.

B. Unlighted buoys without sound equipment are classified as follows:

- (1) Standard nuns and cans (Std).
- (2) Tall nuns and cans (T).
- (3) Special nuns and cans (SP).
- (4) River nuns and cans (RIVER).
- (5) Spars, wood and metal (SPARS).

24-2-5 Specific Types—Standard for Coast Guard Use—

A. Lighted Sound Buoys

- 10 x 39-WE
- 10 x 39-WE-RB
- 9 x 32-WE
- 9 x 32-BE
- 9 x 32-GE
- 8 x 26-BE
- 8 x 26-GE
- 8 x 26-WE
- 6 x 20-BE

B. Lighted Buoys

- 9 x 32-E
- 8 x 26-E-RB
- 8 x 26-E
- 7-FE
- 6 x 20-E
- 5-FE
- 3½-FE

C. Unlighted Sound Buoys

- 9-B or G
- 8-B or G
- 7-W

D. Unlighted Buoys

- Std; 1st, 2d, and 3d class.
- T; 1st, 2d, and 3d class.
- SP; 1st, 2d, and 3d class.
- RIVER; 19, 18, and 15 (inch).
- SPARS; 1st, 2d, 3d, and 4th class.

24-2-10 Specific Types—Non-Standard—

A. There are a considerable number of lighted, and a few unlighted, buoys classed as non-standard which are still approved for use. A list of the more prevalent types is given below:

- 9 x 39-WE or WA
- 9 x 38-WE
- 9 x 32-BA, GA, or A
- 8 x 26-WA, BA, GA, or A
- 8 x 23-WE, WA, BE, BA, or A
- 8 x 20-BE, BA, GA, E, or A
- 8-W
- 7 x 18-BE, BA, E, or A
- Converted "C"-E or A
- 6 x 22-E
- 6 x 20-BA or A
- 6 x 18-A
- Converted BIII-E or A
- 5 x 15-E or A
- 4 x 14-E
- 3½ x 10-E or A

24-3 LIGHTED BUOYS

24-3-1 Purpose—

A. *Lighted sound buoys* provide a sound signal actuated by the motion of the buoy in a seaway in addition to a light powered from an electric battery or acetylene gas source for the guidance of navigation in foggy weather as well as in clear daylight or night.

B. *Lighted buoys* are used where an aid to navigation is of sufficient importance to night navigation to require lighting, but where a sound signal is not required. Lighted buoys are similar to lighted sound buoys but with the bell or gong equipment removed, and are available in types designed for exposed, semi-exposed, and protected locations. In addition, a type suitable for locations in strong river or tidal currents is available.

24-3-5 General Design of Standard Types—

A. *Factors affecting design.*—Due to the variety of conditions of exposure, depth, need for visibility, etc., a buoy is not designed individually for a specific location but is designed in certain standard types to meet the wide range of conditions. The factors that influence the design of buoys are as follows:

- (1) Optical requirements: the distance the light is required to be visible.
- (2) Size of lens and lantern: height of lantern above water.
- (3) Candlepower and divergence of the light source.

(4) Storage capacity required for acetylene cylinders, storage batteries, or radiobeacon transmitter.

(5) Requirements of sound fog signal apparatus.

(6) Depth of water, anticipated weight of sea growth, height and time period of the waves, currents, winds, and ice conditions at the location.

(7) Available facilities for handling and relieving the buoy on station.

B. The principle design characteristics of lighted buoys are the same as for lighted sound buoys except that generally, lighted buoys may be moored in slightly deeper water than their sound counterparts due to the decrease in weight of the buoy while maintaining the same over-all dimensions.

C. See Chapter 23 for additional data on the design of buoys.

24-3-10 Characteristics of Construction—

A. Exposed locations.—The 10 x 39- and 9 x 32-type buoys are designed and constructed for exposed locations where a large chain supporting capacity and structural ruggedness are required. The buoy bodies are large cylindrical floats surmounted by a skeleton steel tower which supports the lantern and sound mechanism, if any. Stability is provided to the structure by a large counterweighted tube attached to the underside of the buoy body.

(1) Vertical fender strips, built up of steel plates and wood and fastened to the counterweight tube, are used to prevent the mooring bridle from chafing the tube.

(2) The mooring bridle is attached to mooring lugs welded 180° apart to the underside of the main body of the buoy. The lugs are made of heavy steel plate with a hole to receive the mooring shackle pin.

(3) Four lifting eyes of ample size are provided for hoisting the buoy. Three are located around the periphery of the top of the main body of the buoy and one on the bottom.

(4) Whistle buoys are designed to ride the waves in a vertical motion in order to compress the air in the whistle tube. Bell or gong buoys have less stability than whistle buoys in order to sound the fog signal which operates by the rocking motion of the buoy.

(5) The heeling angle of any type of lighted buoy in normal rough weather is less than one-half the angle of divergence of the light, so that each flash is directed toward the horizon. Therefore, the light is visible to the mariner at nearly all times.

B. Semi-exposed locations.—Buoys constructed for semi-exposed locations are smaller and more lightly constructed than those intended for exposed waters, although they are similar in type of construction to the larger buoys, also having the pendulum tube and counterweight. A flat bottomed type buoy is provided for locations of shallow depth or strong currents.

C. Protected locations.—Buoys designed for protected locations are smaller and more lightly constructed than those intended for exposed or semi-exposed waters, and are not primarily designed for sound equipment. Any of the other types of sound buoys may be used, provided there is sufficient depth of water under the buoy; and where the motion of the sea is insufficient to actuate a bell, whistle, or gong buoy normally, an electric- or gas-operated bell striker may be installed.

D. Overlap of Classification.—Certain types of buoys primarily designed for semi-exposed and protected locations may be used under conditions of greater severity when the circumstances warrant. For example: The 8 x 26 buoy has been successfully used in exposed locations where the required visibility of the light does not necessitate the greater lantern height of the 9- and 10-foot buoys. The TFE has also been used in fairly exposed locations.

E. Sketches of buoys shown on the following pages are for general illustrative purposes only. See appropriate Headquarters drawings for accurate data.

24-3-15 Specific Standard Types for Exposed Locations—

A. The 10 x 39-WE (fig. 24-1) is designed for deep water in exposed locations where maximum visibility and long periods between servicing are desired. It is equipped with an air whistle which is blown by wave action. This buoy may be used wherever there is sufficient depth of water to swing the counterweight tube and the necessary wave action to operate the whistle.

(1) See the tables under paragraph 24-3-40 (A) for lighting equipment, focal plane height, mooring appendages, weight, etc. The sizes of sinker and chain shown in the table are intended only as a guide for average conditions and the specific requirements for each location should always be considered.

(2) The extreme maximum depth in which this buoy can be moored is 75 fathoms, using 1½-inch chain. Three hundred and eighty pounds will submerge the buoy about 1 inch.

(3) There are four pockets in the main body of the buoy which contain storage batteries. These pockets are open within the body of the buoy and are made watertight by means of a rubber gasket and a ½-inch steel cover plate held in place by 12 brass toggle bolts. The buoy body is provided with a vent which vents all the batteries in all the pockets. The battery racks and wiring to the lantern are connected as described in Chapter 21, Electric Apparatus.

(4) See paragraph 24-3-35 (A) for a description of the air whistle which is operated automatically by the action of the sea.

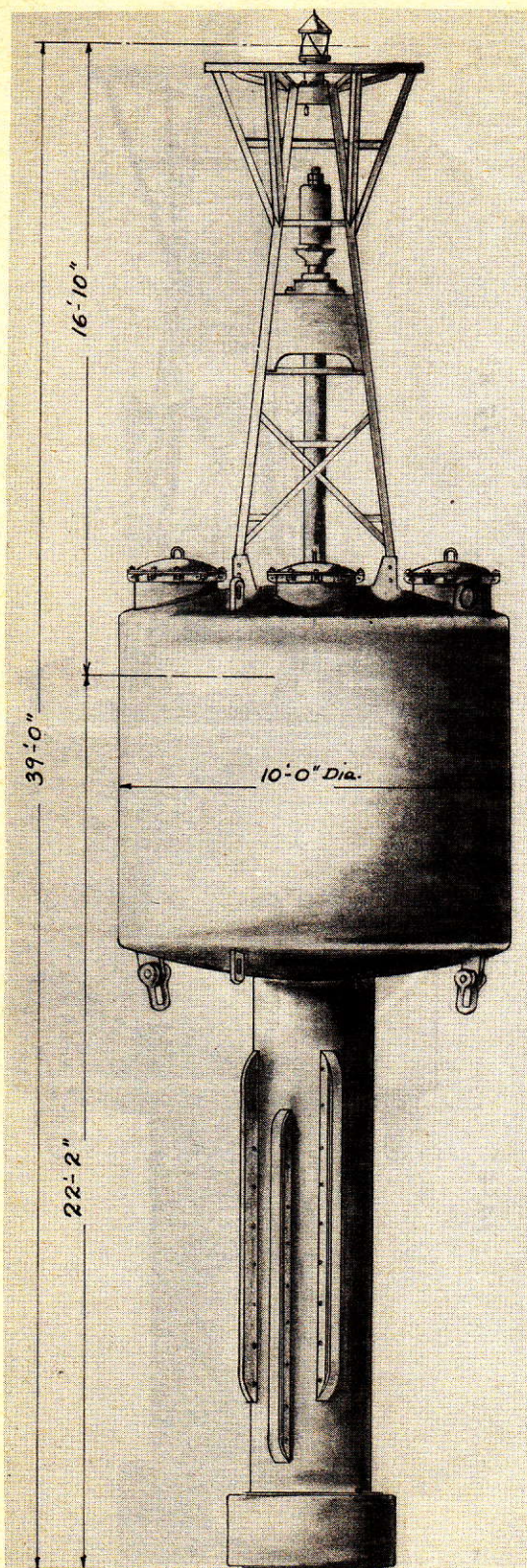

FIGURE 24-1.—10 x 39 WE lighted buoy (whistle electric).

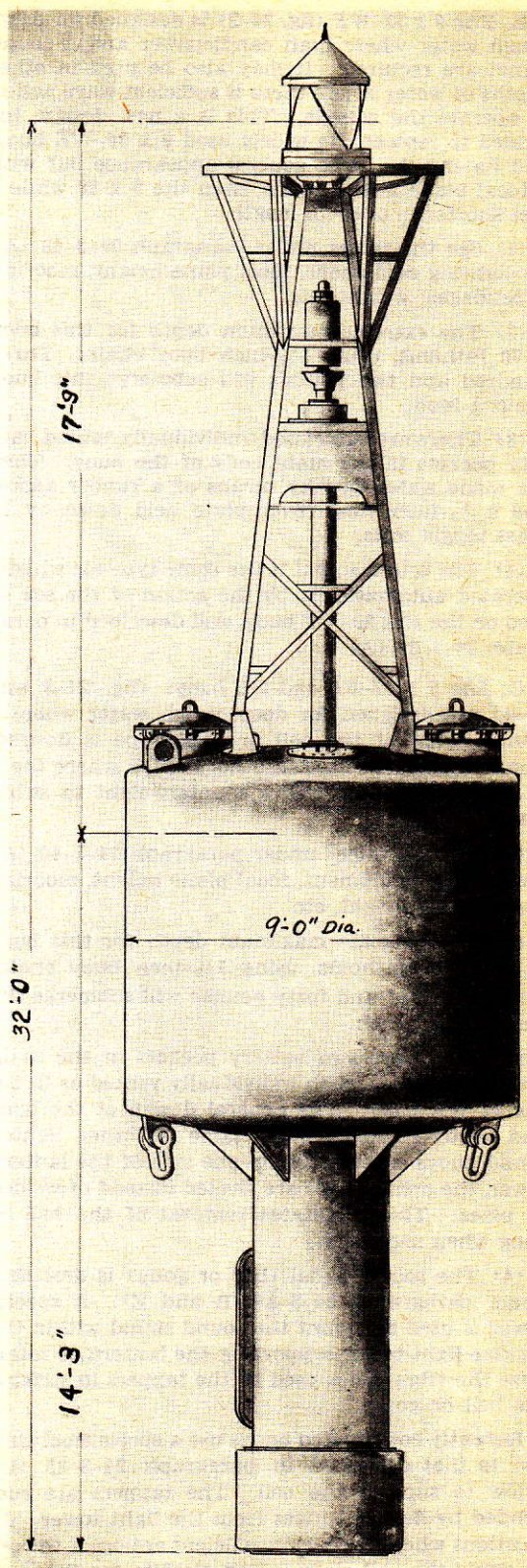

FIGURE 24-2.—9 x 32 WE lighted buoy (whistle electric).

B. The 9 x 32-WE (fig. 24-2) is designed for deep, rough water where high candlepower and a sound signal are required. It may also be used in other depths of water where there is sufficient wave action to operate the whistle. This is a new design, intended to replace the widely used 9 x 38-WE buoy, and having the same general appearance but with a focal plane 2 feet higher than the 9 x 38 while 6 feet shorter in over-all length.

(1) See the tables under paragraph 24-3-40 (A) for lighting equipment, focal plane height, mooring appendages, weight, etc.

(2) The extreme maximum depth for this buoy is 70 fathoms, using 1½-inch buoy chain. Three hundred and two pounds will submerge this buoy about 1 inch.

(3) There are two closed, individually vented battery pockets in the main body of the buoy. They are made watertight by means of a rubber gasket and a ½-inch steel cover plate held down by 12 brass toggle bolts.

(4) The sound signal is the same type air whistle operated automatically by the action of the sea as used on the 10 x 39-WE buoy, and described in paragraph 24-3-35 (A).

C. The 9 x 32-BE and GE buoys (fig. 24-3 and 24-4) are designed for deep, rough water where a sound signal of the bell or gong type is desired. The buoy may be used in other depths where there is sufficient water for the counterweight to swing freely.

(1) See the tables under paragraph 24-3-40 (A) for lighting equipment, focal plane height, mooring appendages, weight, etc.

(2) The extreme maximum depth for this buoy is about 60 fathoms, using 1½-inch buoy chain. Three hundred and forty pounds will submerge the buoy about 1 inch.

(3) There are two battery pockets in the main body of the buoy, each individually vented as in the 9 x 32 WE buoy. The general design of the buoy and lantern tower is the same as other lighted sound buoys except that on one side of the lantern tower, the cross braces are riveted instead of welded in place. This facilitates removal of the bell or gong when necessary.

(4) The sound signal (bell or gong) is described under paragraphs 24-3-35 (B and E). A special tower is used to mount the sound signal within the regular light tower supporting the lantern, to minimize the vibration caused by the tappers in striking the bell or gongs.

Recently constructed buoys use a special stool similar to that described in paragraph 24-3-35 (D) below to support the bell. The tappers are suspended by flexible hinges from the light tower. In locations where there is insufficient action of the sea to swing the bell clappers, an electric- or CO₂ gas-operated mechanical bell striker is used. (See Chapter 25, Fog Signals.)

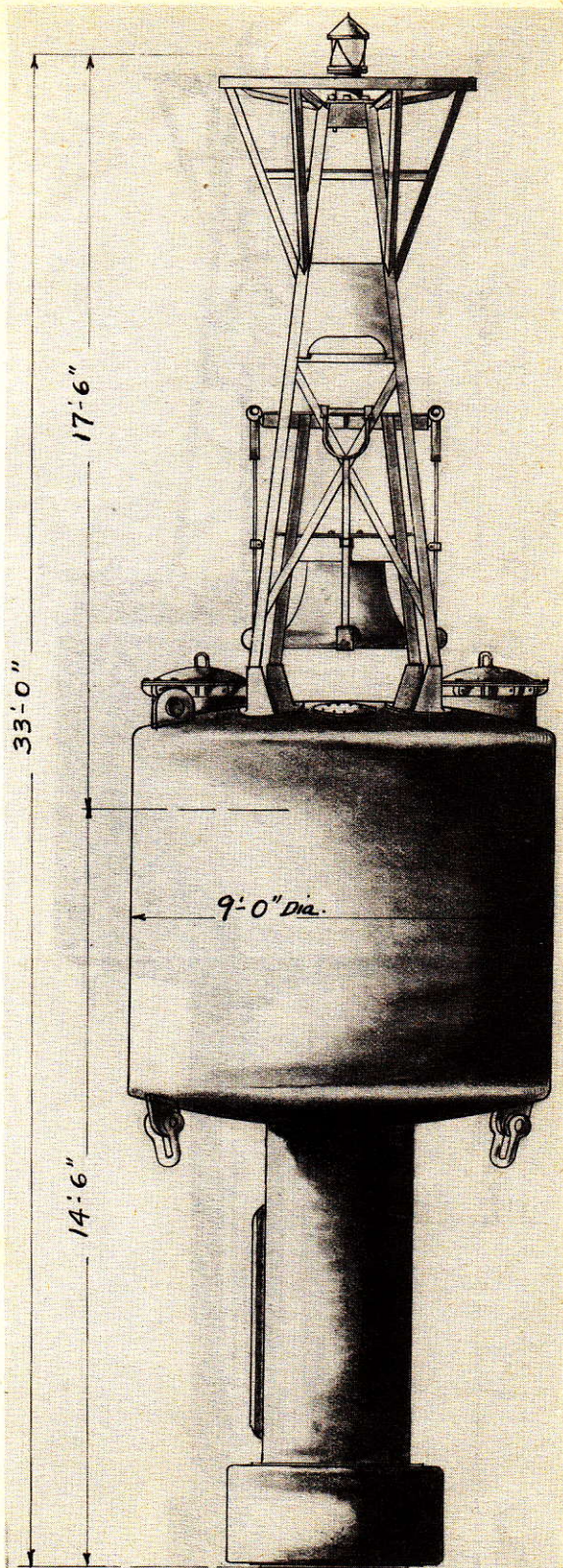

FIGURE 24-3.—9 x 32 BE lighted buoy (bell electric).

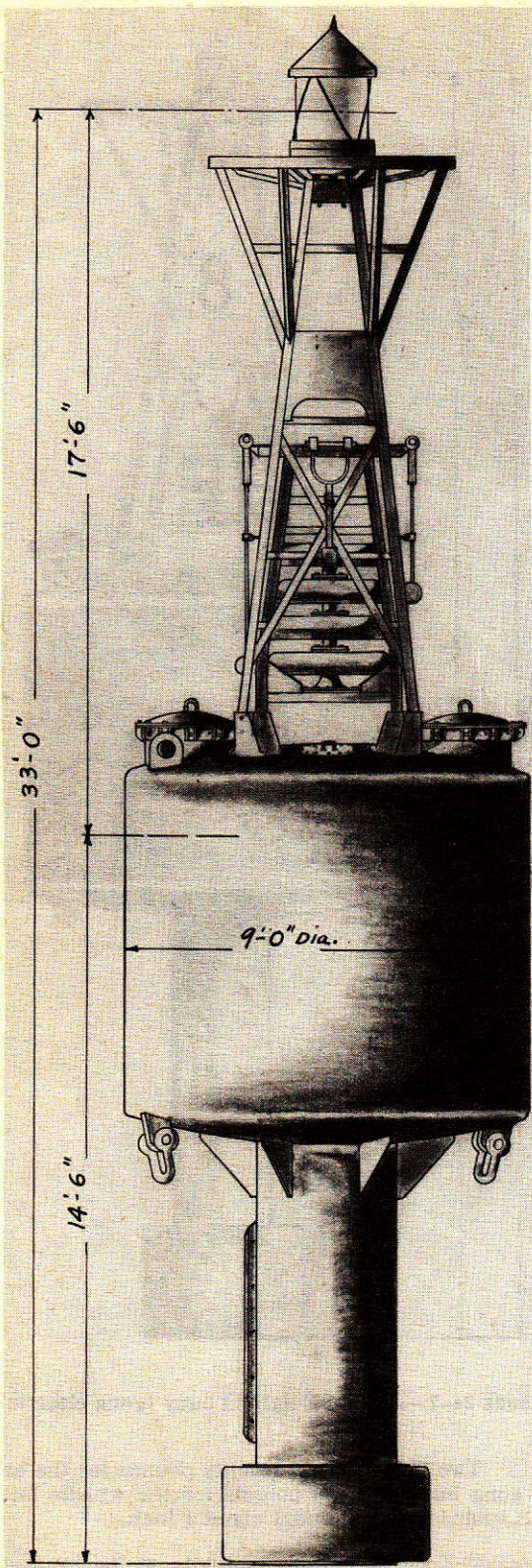

FIGURE 24-4.—9 x 32 GE lighted buoy (gong electric).

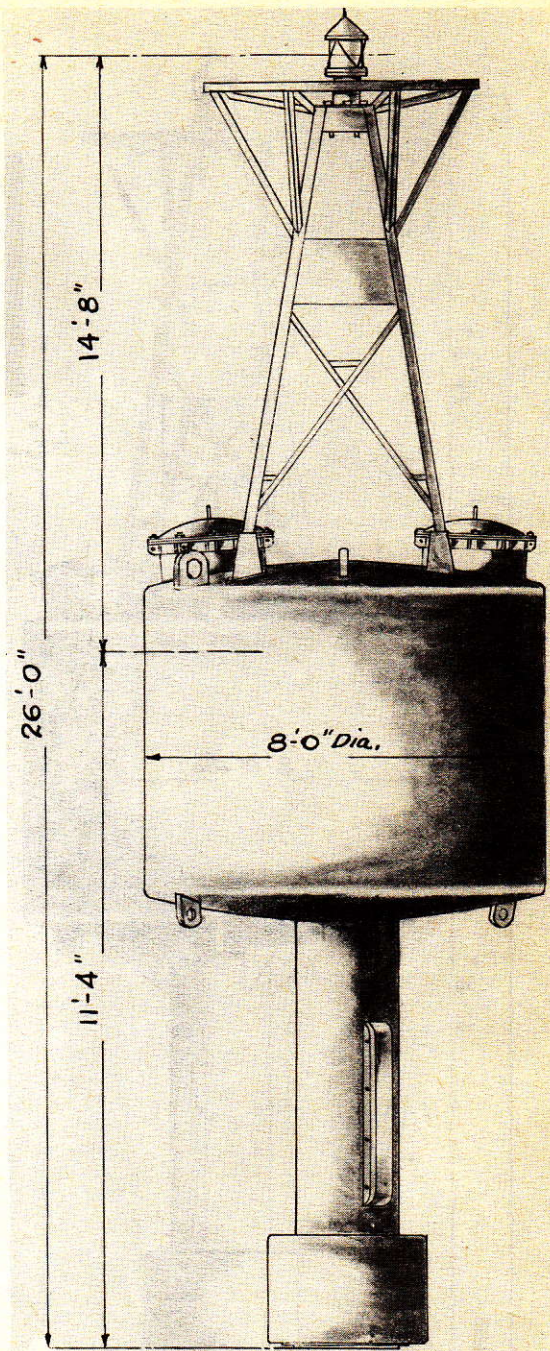

FIGURE 24-5.—8 x 26E lighted buoy (electric).

24-3-20 Specific Standard Types for Exposed or Semi-exposed Locations—

A. The 8 x 26 group (8 x 26-WE, BE, GE and E) (figs. 24-5 to 24-8 inclusive) is a versatile group of buoys which can be used in a variety of exposures and depths.

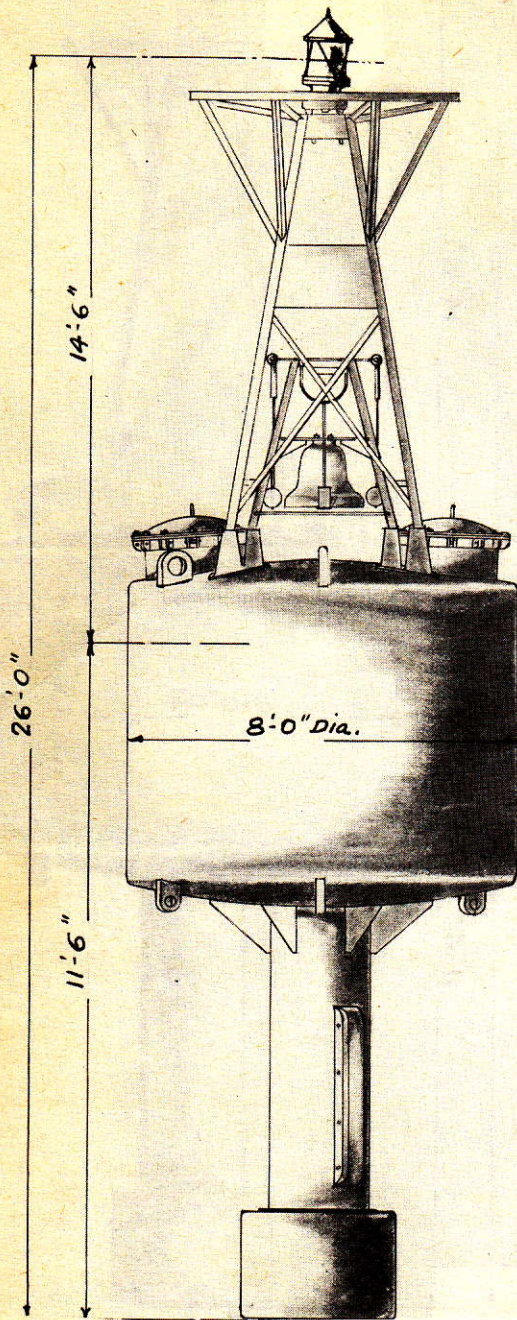

FIGURE 24-6.—8 x 26BE lighted buoy (bell electric).

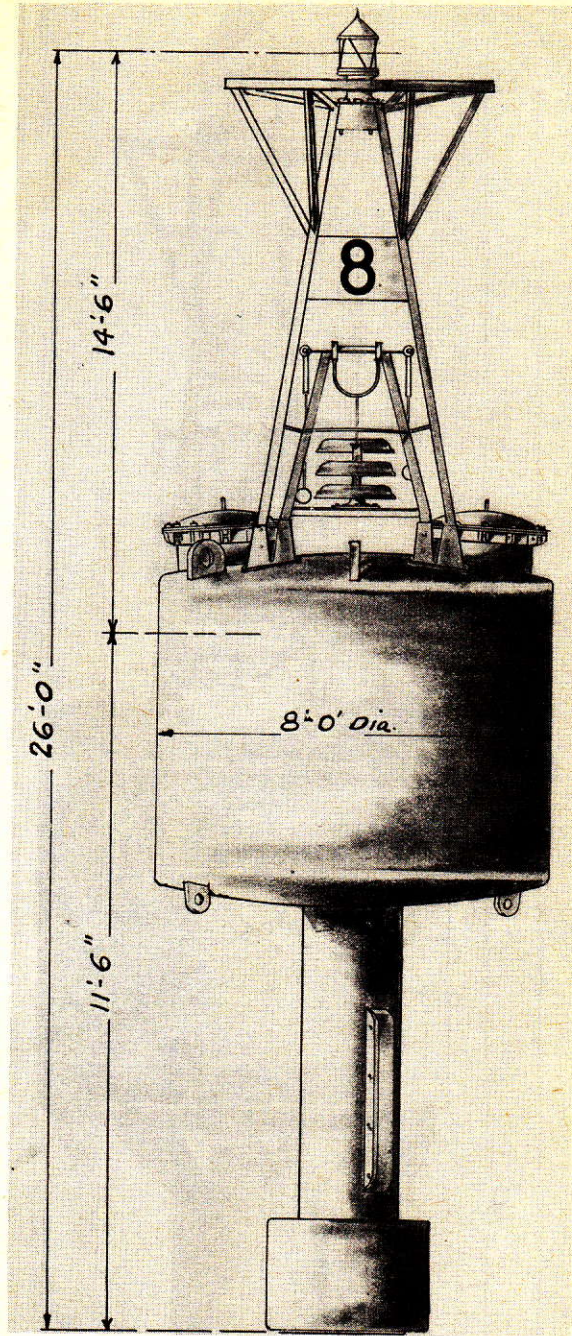

FIGURE 24-7.—8 x 26GE lighted buoy (gong electric).

(1) See the tables under paragraph 24-3-40 (B) for lighting equipment, focal plane height, mooring appendages, weight, etc.

(2) The extreme maximum depth for the 8 x 26 group, using $1\frac{1}{4}$ -inch buoy chain is as follows:

- (a) 8 x 26-WE, 50 fathoms.
- (b) 8 x 26-BE/GE, 75 fathoms.
- (c) 8 x 26-E, 80 fathoms.

(3) Two hundred and seventy pounds for the bell or gong buoy and 250 pounds for the whistle buoy will submerge these buoys about 1 inch.

(4) There are two individually vented battery pockets in the main body of the buoy which are made watertight by means of a rubber gasket and a steel cover plate held down by 12 brass toggle bolts.

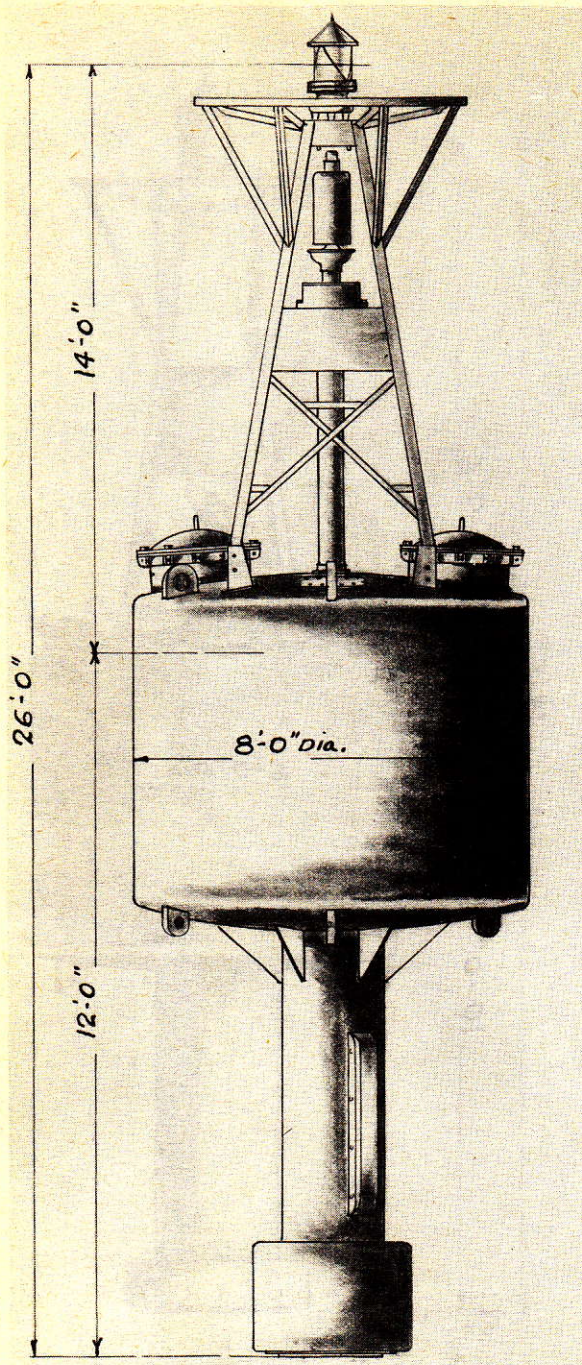

FIGURE 24-8.—8 x 26-WE lighted buoy (whistle electric).

(5) The air whistle is similar to that described for the larger lighted sound buoys in paragraph 24-3-35 (A). The bell and gong sound equipment is suspended from separate towers within the lantern tower and is described in paragraphs 24-3-35 (C) and (F). Recently constructed buoys use the bell stool referred to in paragraph 24-3-15 (C) (4) above.

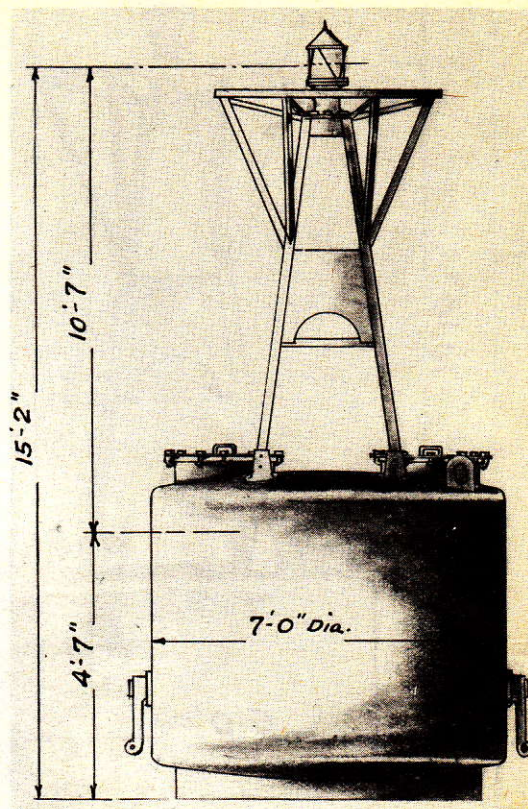

FIGURE 24-9.—7-FE lighted buoy (flat electric).

24-3-25 Specific Standard Types for Semiexposed Locations—

A. The 7-FE (fig. 24-9) is designed for semiexposed locations and a wide range of depths, and for tidal or stream currents.

(1) See the tables under paragraph 24-3-40 (B) for lighting equipment, focal plane height, mooring appendages, weights, etc.

(2) The extreme maximum depth, using $1\frac{1}{4}$ -inch buoy chain, is 50 fathoms. This buoy requires concrete ballast, 2,000 pounds being the average requirement. It is delivered without ballast and the district may alter the weight of ballast to suit local requirements. Two hundred and five pounds will submerge this buoy about 1 inch.

(3) The two battery pockets are open to the inside of the main body of the buoy, permitting the use of a single vent tube. The battery pockets are made watertight by means of a rubber gasket and steel cover plate held down by 12 brass toggle bolts.

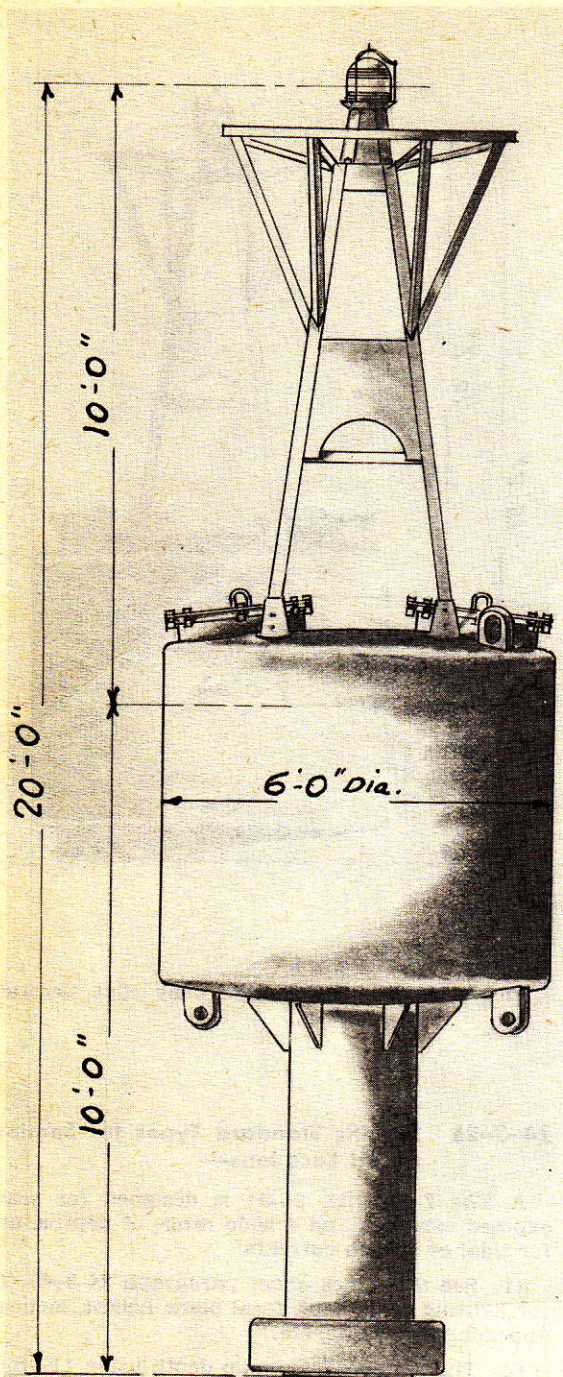

FIGURE 24-10.—6 x 20E lighted buoy (electric).

B. The 6 x 20-BE and E (figs. 24-10 and 11) are designed to meet requirements in semi-exposed locations and for normal depths of from 20 to 100 feet.

(1) See the tables under paragraph 24-3-40 (B) for lighting equipment, focal plane height, mooring appendages, weight, etc.

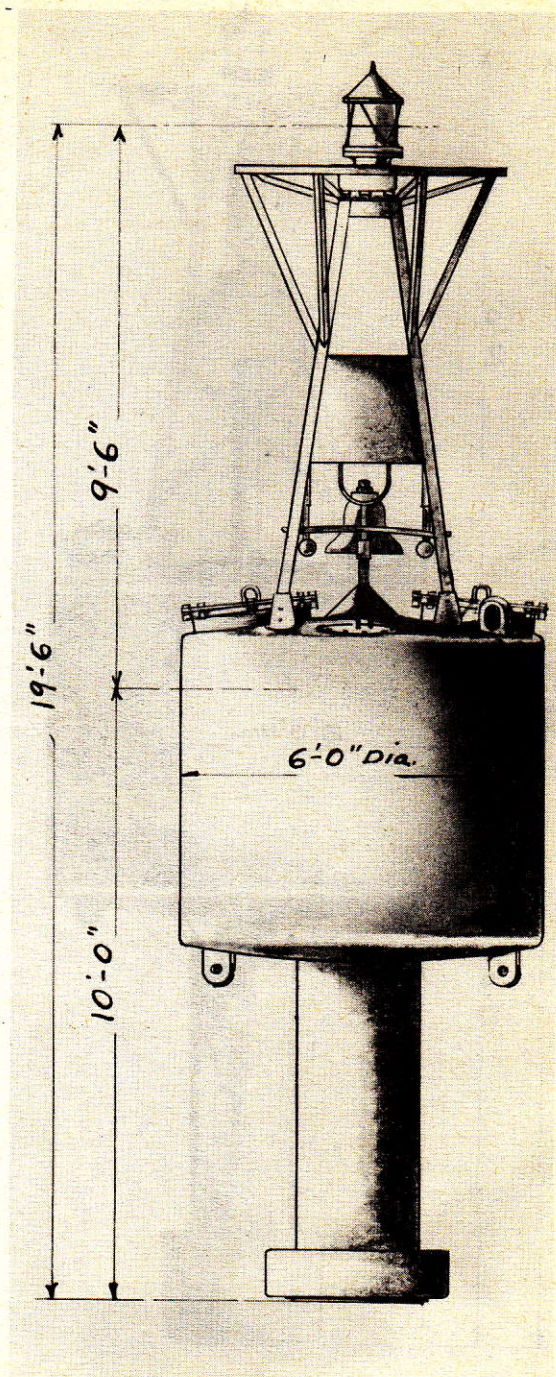

FIGURE 24-11.—6 x 20BE lighted buoy (bell electric).

(2) The extreme maximum depth, using $1\frac{1}{8}$ -inch buoy chain, is 40 fathoms. One hundred and fifty pounds will submerge this buoy about 1 inch.

(3) The electric buoy battery pockets are open to the inside of the buoy. A single vent tube ventilates the entire buoy body and pockets.

(4) See paragraph 24-3-35 (D) for a description of the bell used on this buoy.

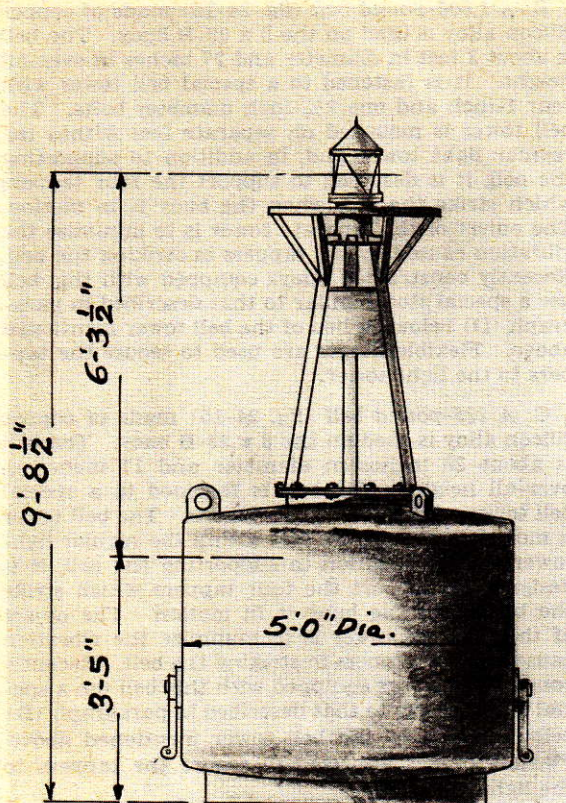

FIGURE 24-12.—5-FE lighted buoy (flat electric).

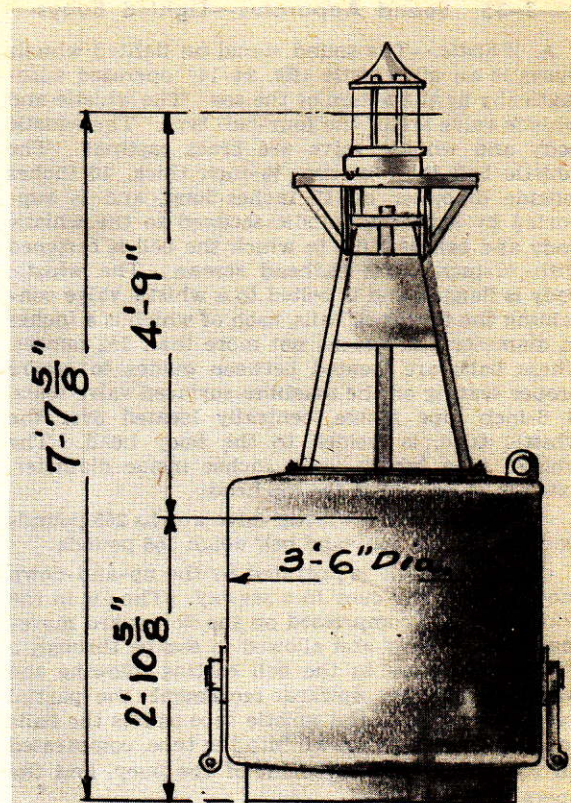

FIGURE 24-13.—3½-FE lighted buoy (flat electric).

C. The 5-FE (fig. 24-12) is designed for semi-exposed locations and for tidal or stream currents of 3 to 4 knots.

(1) See the tables under paragraph 24-3-40 (B) for lighting equipment, focal plane height, mooring appendages, weight, etc.

(2) The extreme maximum depth for mooring this buoy is 30 fathoms, using 7/8-inch buoy chain. One hundred and five pounds will submerge this buoy about 1 inch.

(3) The single open battery pocket is located in the center of the main body of the buoy which is ventilated by a single vent. The lantern tower, a three-legged skeleton structure about 4½ feet high, is welded directly to the battery pocket cover. This cover is 26 inches in diameter and is secured over a rubber gasket by 12¾-inch bolts.

24-3-30 Specific Standard Type for Protected Locations—

A. The 3½-FE (fig. 24-13) is intended for shoal water, moderate currents and sheltered locations. It is designed to stand upright in currents up to four knots.

(1) See the tables under paragraph 24-3-40 (B) for lighting equipment, focal plane height, mooring appendages, weight, etc.

(2) The extreme maximum depth for mooring this buoy is 12 fathoms, using ¾-inch chain. Fifty-one pounds will submerge this buoy about 1 inch.

(3) Like the 5-FE buoy, the battery rack is placed in the center of the buoy. It is held in place by four T-shaped guides. The lantern tower is about 3 feet high and is welded directly to the 26-inch cover. This cover is secured over a rubber gasket by 12¾-inch bolts.

24-3-35 Sound Apparatus—Lighted Buoys—

A. *Whistle.*—The sound signal on lighted whistle buoys is an air whistle (fig. 24-14) operated automatically by the action of the sea. The whistle and whistle valve are of the four-ball type. The whistle body and whistle valve are brass castings. The whistle bell is of bronze, $\frac{1}{8}$ -inch thick, 10 inches outside diameter by 17 inches long, and is supported by a bronze spindle screwed to the whistle body and bell casting, to which the bell is fastened with $\frac{1}{4}$ -inch brass flathead screws. The whistle body is flanged and is bolted to a whistle valve containing the four cork balls, each of which is 4 inches in diameter and weighs not more than $7\frac{1}{4}$ ounces. These balls are located between guides to assure proper seating on the machine-surfaced valve seats. A 6-inch pipe flange, centrally located over the whistle tube, is welded to the buoy head. The whistle tube, which is 36 inches inside diameter, extends 25 feet below the top head.

(1) The four-ball whistle valve weighs 265 pounds and the whistle body and bell weigh 155 pounds.

(2) The whistle is operated by the up-and-down movement of the buoy in a seaway. The air in the whistle tube is compressed on the downward movement of the buoy and allowed to escape through a $\frac{1}{32}$ -inch aperture in the bell casting, blowing the whistle. On the upward movement the partial vacuum created in the whistle tube causes the balls to lift; air is again drawn into the tube, compressed on the downward movement of the buoy, and the operation is repeated.

(3) The balls should be inspected every 2 years to insure proper functioning of the whistle. A gasket made of a good grade of smooth paper should be placed between the bonnet and the whistle valve body.

(4) The whistle described above is used on all standard lighted whistle buoys, i. e. 10 x 39W, 9 x 32W and 8 x 26W; also on the 9 x 38W.

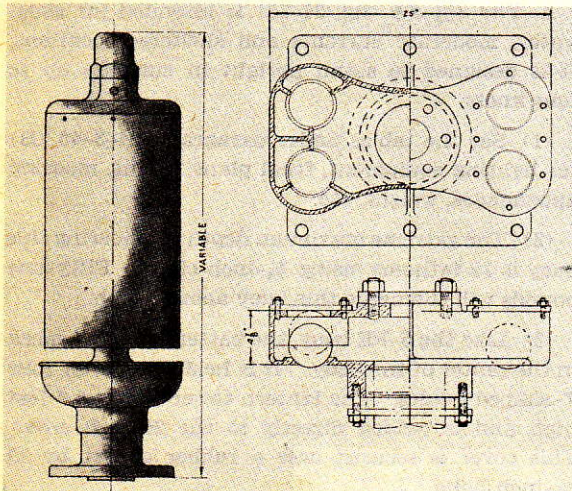

FIGURE 24-14.—Buoy whistle and valve.
(four ball).

B. A 1,000-pound bell (fig. 24-15) made of copper silicon alloy is used on the 9 x 32-B buoy. The bell is about 3 feet in diameter and 27 inches in over-all height. It is fastened to a special bell tower with four 1-inch and one $2\frac{1}{4}$ -inch diameter bolts. The bell tower is mounted on separate feet within the regular light tower and, in addition to supporting the bell, it is designed to support the four tappers which strike the bell when the buoy is in motion. The object of the separate tower is to minimize the vibration caused by the tappers in striking the bell. Recently constructed buoys equipped with this bell use a special stool similar to that described in paragraph (D) below, in lieu of the bell tower mentioned above. Flexible hinges are used to secure the tappers to the light tower.

C. A 225-pound bell (fig. 24-15) made of copper silicon alloy is used on the 8 x 26-B buoy. The bell is about 20 inches in diameter and 17 inches in over-all height. The bell is fastened to a special bell tower with three $1\frac{1}{2}$ -inch bolts. The bell tower is mounted on separate feet within the regular light tower and, in addition to supporting the bell, it is designed to support the four tappers which strike the bell when the buoy is in motion. The object of the separate tower is to minimize the vibration caused by the tappers in striking the bell. Recently constructed buoys equipped with this bell use a special stool similar to that described in paragraph (D) below, in lieu of the bell tower mentioned above. Flexible hinges are used to secure the tappers to the light tower.

D. An 85-pound bell (fig. 24-15) made of copper silicon alloy is used on the 6 x 20 buoy. The bell is 15 inches in diameter and $12\frac{1}{4}$ inches in over-all height. The bell stool, made from $1\frac{1}{2}$ -inch steel rod, together with a conical hood, is welded directly to the top head of the buoy. A shoulder plate, upon which the bell rests, is welded to the rod about 15 inches above the head. The bell is held against

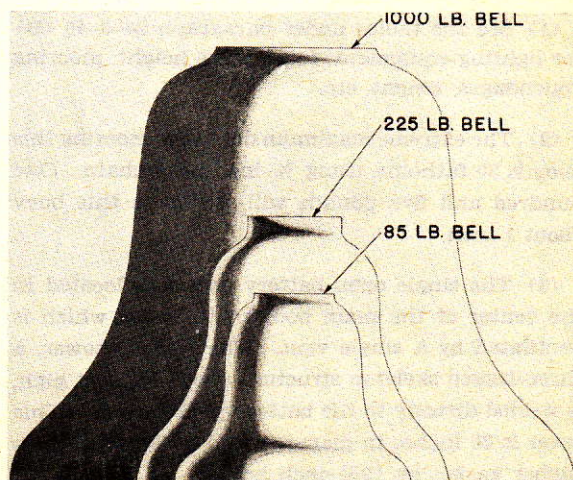

FIGURE 24-15.—Various sizes of buoy bells.

the plate by a large brass hexagonal nut that fits the 1½-inch threaded main rod. Four standard type tappers are suspended from a point on the inside of the light tower near the bottom of the day-mark.

E. *Four gongs* (fig. 24-16) made of copper silicon alloy are used on the 9 x 32G buoy. The gongs are 36 inches in diameter and weigh approximately 290, 346, 405, and 445 pounds, respectively. The gongs are fastened to a special cast gong stand which is in turn fastened to a special gong tower. The tower is mounted on separate feet within the regular light tower and, in addition to supporting the gongs, it is designed to support the four tappers which strike the gongs when the buoy is in motion. There is one tapper for each gong; the sound-signal effect is that of a chime. The object of the separate tower is to minimize the vibration caused by the tappers in

striking the gongs. Recently constructed buoys use a special stool in lieu of the gong tower mentioned above.

F. *Three gongs* (fig. 24-17) made of copper silicon alloy are used on the 8 x 26G buoy. The gongs are 20 inches in diameter and weigh approximately 70, 80, and 85 pounds, respectively. The gongs are fastened to a special cast gong stand which is in turn fastened to a special gong tower. The tower is mounted on separate feet within the regular light tower and, in addition to supporting the three gongs, it is designed to support the three tappers which strike the gongs when the buoy is in motion. The sound-signal effect produced is that of a chime. The object of the separate tower is to minimize the vibration caused by the tappers in striking the gongs. Recently constructed buoys use a special stool in lieu of the gong tower mentioned above.

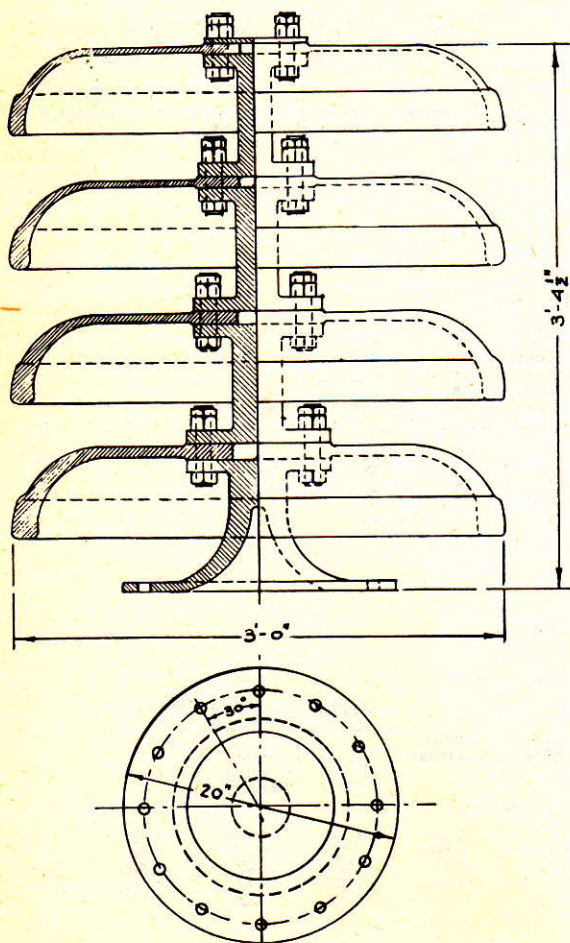

FIGURE 24-16.—36-inch gongs and stand.

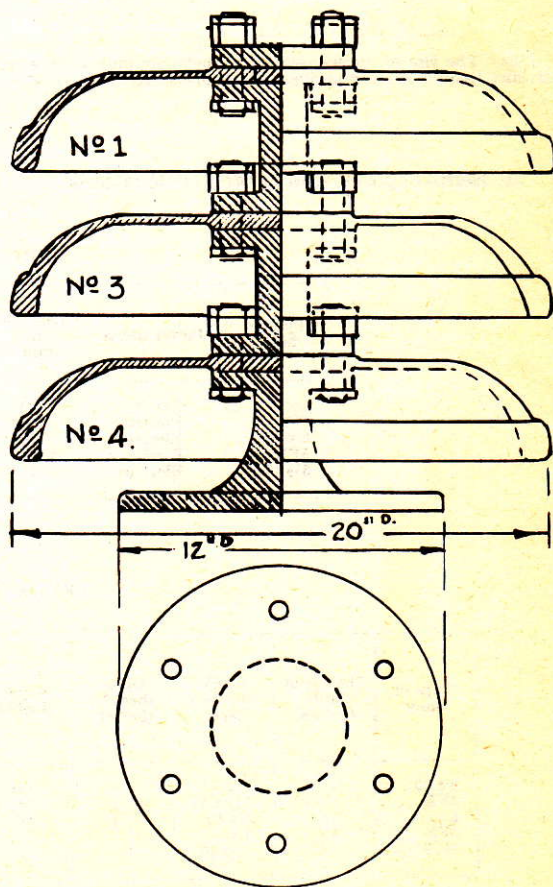

FIGURE 24-17.—20-inch gongs and stand.

24-3-40 Equipment and Appendages for Standard Lighed Buoy—

A. Exposed locations.

LIGHTING EQUIPMENT

Type of buoy	Power source	Lantern size (mm.)	Approximate height of focal plane (feet— inches)	Preferred voltage	Battery racks	
					Type	No.
10 x 39.....	Electric	200	16—10	12	44 or 34	3 or 4
9 x 32.....	Electric	200	16—4/17—9	12	34	2

MOORING APPENDAGES AND WEIGHTS

Type of buoy	Shackle at buoy (inches)	Bridle (inches x feet)	Other shackles (inches)	Swivel (inches)	Chain (inches)	Sinker (pounds)	Approximate weights (pounds)		
							Buoy body	Light/sound equipment	Total
10 x 39.....	2½	1½ x 26	2	2	1½	8,500	23,360	6,870	30,230
9 x 32.....	2½	1½ x 18	2	2	1½	6,500	23,000/ 21,900	3,130	26,130/ 25,030

Note.—The size of appendages given above are only average recommendations. Consideration should be given to the requirements of each individual location in selecting appropriate appendages. See sec. 27-5-10 for further discussion on the selection of a mooring.

B. Semi-exposed and protected locations.

LIGHT EQUIPMENT

Type of buoy	Power source	Lantern size (mm.)	Approximate height of focal plane (feet— inches)	Preferred voltage	Battery racks	
					Type	No.
8 x 26.....	Electric	200	12—8	12	34	2
7FE.....	Electric	200	10—7	12	23	2
6 x 20.....	Electric	200	10—0	12	23	2
5FE.....	Electric	150/200	6—3½	6	23	1
3½FE.....	Electric	150	4—9	6	13	1

APPENDAGES AND WEIGHTS

Type of buoy	Shackle at buoy (inches)	Bridle (inches x feet)	Other shackles (inches)	Swivel (inches)	Chain (inches)	Sinker (pounds)	Approximate weights (pounds)		
							Buoy body	Light/sound equipment	Total
8 x 26.....	2	1¼ x 15	1¾	1¾	1¼	5,000	12,500	2,710	15,210
7FE.....	1¾	1¼ x 15	1¾	1¾	1¼ or 1½	5,000	5,760	3,550	9,310
6 x 20.....	1¾	1 x 12	1¾	1½	1½	4,000	5,400	800	6,200
5FE.....	1	1 x 12	1	1	¾ or 7/8	3,000	2,770	740	3,510
3½FE.....	1	¾ x 10	1	1	¾ or 7/8	2,000	1,150	320	1,470

Note.—The sizes of appendages listed above are only average recommendations. Consideration should be given to the requirements of each individual location. See sec. 27-5-10 for further discussion on the selection of a mooring.

24-3-45 Specific Nonstandard Types—

A. There are numerous types of buoys presently approved for use which will be replaced by the standard types listed under sections 24-3-15 to 24-3-30, inclusive, upon the completion of their useful life. Brief descriptions of some of the most commonly found nonstandard lighted buoys are given in the following paragraphs. See the tables under section 24-3-50 for lighting equipment, mooring appendages, focal plane height, weight, etc., for all buoys under this section.

Acetylene buoys are no longer considered standard for Coast Guard use, although many buoys of this type are still in use at present and may be expected to so continue for a number of years to come.

B. The 9 x 39 (fig. 24-18) is an electric or acetylene buoy with counterweighted pendulum tube similar to the 10 x 39 buoy. It is designed for use in exposed locations. There are two battery or cylinder pockets in the body of the buoy.

C. The 9 x 38W is a widely used electric or acetylene buoy recently classified as nonstandard pursuant to the development of the 9 x 32WE buoy.

D. The 8 x 26A group is similar to the 8 x 26E group described in paragraph 24-3-20 (A), figures 24-5 to 24-8, inclusive.

E. The 8 x 23W (fig. 24-18) is an electric or acetylene whistle buoy with a short counterweighted pendulum tube. It is used in semi-exposed and exposed locations. There are two closed individually vented battery or cylinder pockets in the body of the buoy. The whistle is similar to that described under paragraph 24-3-35 (A). The 8 x 23 is also available as a BE, BA and A buoy.

F. The 8 x 20 group (fig. 24-18) is an electric or acetylene buoy used in semi-exposed locations. It may be equipped with a 225-pound bell. It has a cylindrical body with a counterweighted inverted conical base. The body contains two closed individually vented pockets. This buoy may not be moored in depths less than 13 feet.

G. The 7 x 18 (fig. 24-18) is a widely used electric or acetylene buoy designed for semi-exposed locations. It is similar to the 8 x 20 buoy except that there are four small closed pockets in the body of the buoy. This buoy is not stable enough to support more than one man aboard at one time. It may not be moored in depths of less than 12 feet.

H. The converted C type (fig. 24-20) is an obsolete acetylene buoy that is rapidly disappearing from use. It has a deeply tapered inverted conical bottom and the lantern is supported by a metal tube rather than a skeleton tower as on all other lighted buoys. This buoy was converted from an early type that used Pintsch gas for a power source. A single large pocket slants diagonally toward the center of the buoy, although a few of these buoys have three small pockets grouped around the lantern support tube.

I. The converted B III (fig. 24-20) is an inverted conical bottom electric or acetylene buoy with counterweight, converted from an early gas-type buoy. It is most commonly used in the Ninth District. Two small pockets are contained in the body of the buoy.

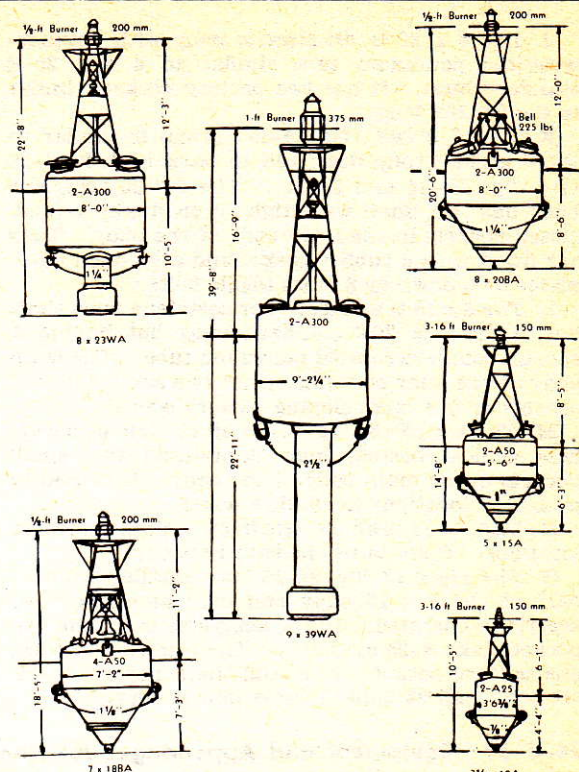

FIGURE 24-18.—Nonstandard lighted buoys.

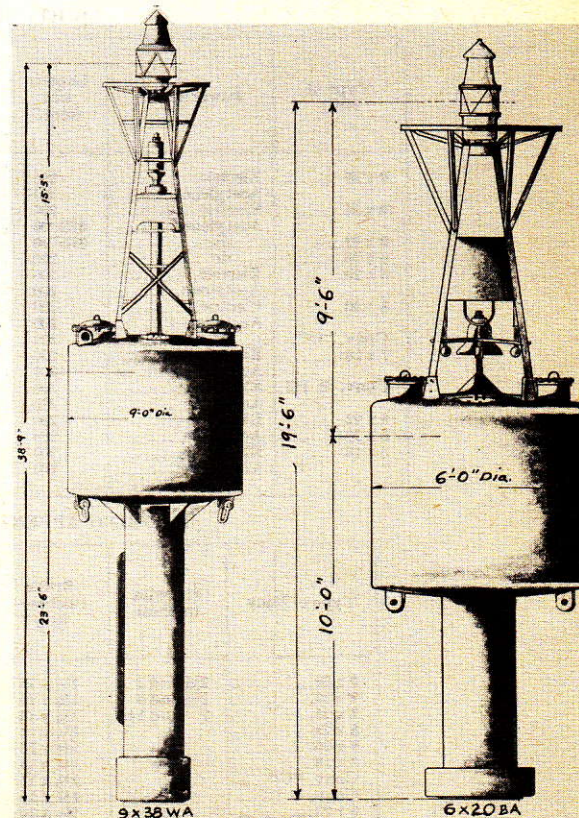

FIGURE 24-19.—9 x 38 WA and 6 x 20 BA nonstandard lighted buoys.

J. The 6 x 22 is an electric buoy with counter-weighted pendulum tube similar to a 6 x 20-E standard buoy. It has two battery pockets similar to the 6 x 20E buoy.

K. The 6 x 20A (fig. 24-19) group is similar to the 6 x 20E group described in paragraph 24-3-25 (B) (figs. 24-10 and 24-11). The 6 x 20 acetylene buoy has two small watertight individually vented, closed pockets in the main body of the buoy. They are fitted with a rubber gasket and a 3/16-inch cover plates held down by 8 brass toggle bolts.

L. The 6 x 18 is an electric or acetylene buoy similar to the 6 x 20E standard buoy but having a shorter counterweighted pendulum tube. The main body of the buoy contains either two small cylinder pockets or one large sloping battery pocket.

M. The 5 x 15 (fig. 24-18) is an electric or acetylene conical bottom buoy containing two small pockets in the main body of the buoy. It is used in protected locations in shallow water.

N. The 4 x 14 is an electric buoy used in protected locations. It contains one battery pocket.

O. The 3 1/2 x 10 (fig. 24-18) is a smaller counter-part of the 5 x 15 buoy and may be electric- or acetylene-operated. In the acetylene buoy, the two pockets take A-25 cylinders. The electric buoy has one battery pocket. This and the standard 3 1/2 FE are the smallest lighted buoys now in service.

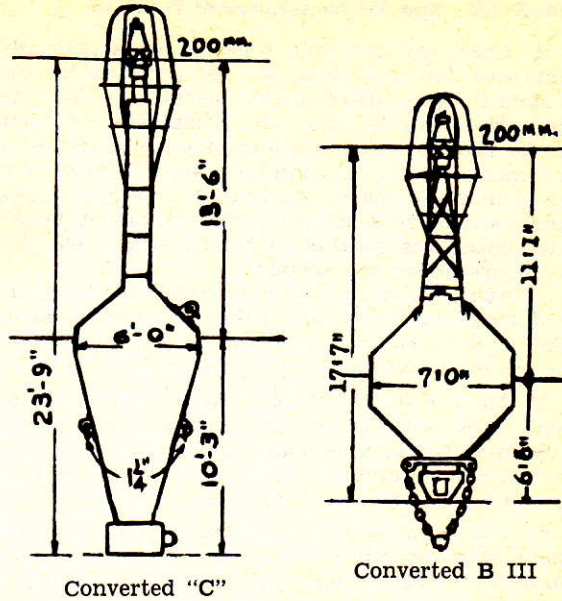

FIGURE 24-20.—Converted "C" and "B III" non-standard lighted buoys.

24-3-50 Equipment and Appendages for Non-Standard Lighted Buoys—

A. Exposed and semi-exposed locations.

LIGHTING EQUIPMENT

Type of buoy	Power source	Lantern size (mm.)	Approximate height of focal plane (feet-inches)	Preferred voltage	Battery racks or acetylene cylinders	
					Type	Number
9 x 39	Electric	200	16-9	12	44	2
	Acetylene	375	16-9	—	A-300	2
9 x 38	Electric	200	15-10	12	34	2
	Acetylene	375/200	15-10	—	A-300	2
9 x 32	do.	375/200	16-4	—	A-300	2
8 x 26	do.	200	12-8	—	A-300	2
8 x 23	Electric	200	12-3	12	34	2
	Acetylene	200	12-3	—	A-300	2
8 x 20	Electric	200	12-0	12	34	2
	Acetylene	200	12-0	—	A-300	2
Conv. "C"	do.	200	13-6	—	A-300 or A-50	1 or 3
7 x 18	Electric	200	11-2	12	31	4
	Acetylene	200	11-2	—	A-50	4
Conv. B III	Electric	200	11-1	12	31	2
	Acetylene	200	11-1	—	A-50	2
6 x 22	Electric	200	10-0	12	23	2
6 x 20	Acetylene	200	9-9	—	A-50	2
6 x 18	Electric	200	7-9	12	23	2
	Acetylene	200	7-9	—	A-50	2

MOORING APPENDAGES AND WEIGHTS

Type of buoy	Shackles (inches)	Bridle (inches-feet)	Swivel (inches)	Chain (inches)	Sinker (pounds)	Approximate weight of buoy (pounds)
9 x 39	2 1/2 and 2	1 1/2 x 26	2	1 3/8	8,500	24,200
9 x 38	2 1/2 and 2	1 1/2 x 26	2	1 3/8	6,500	20,610
8 x 26	2 and 1 3/4	1 1/4 x 15	1 3/4	1 1/4	5,000	12,500
8 x 23	2	1 1/4 x 15	1 3/4	1 1/4	5,000	15,800
8 x 20	2	1 1/4 x 15	1 3/4	1 1/4	5,000	15,600
7 x 18	1 3/4	1 1/4 x 15	1 1/2	1 1/4	5,000	9,300
Conv. "C"	2	1 1/4 x 15	1 3/4	1 1/4	5,000	7,700
Conv. B III	1 3/4	1 1/4 x 15	1 3/4	1 1/4	4,000	6,900
6 x 22	1 3/4	1 1/2 x 10	1 1/2	1 1/4	4,000	6,500
6 x 20	1 3/4	1 x 12	1 1/2	1 1/4	4,000	5,400
6 x 18	1 3/4	1 1/2 x 10	1 1/2	1 1/4	4,000	6,000

B. Protected locations.

LIGHTING EQUIPMENT

Type of buoy	Power source	Lantern size (mm.)	Approximate height of focal plane (feet— inches)	Pre-ferred voltage	Battery racks or acetylene cylinders	
					Type	Number
5 x 15.....	Electric	150	8-5	6	31	2
	Acetylene	150	5-15	6	A-50	2
4 x 14.....	Electric	150	7-9	6	31	1
3½ x 10.....	Electric	150	6-10	6	31	1
	Acetylene	150	3½-10	6	A-25	2

MOORING APPENDAGES AND WEIGHTS

Type of buoy	Shackles (inches)	Bridle (inches— feet)	Swivel (inches)	Chain (inches)	Sinker (pounds)	Approximate weight of buoy (pounds)
5 x 15.....	1½	1 x 12	1	¾	3,000	5,200
4 x 14.....	1½	1 x 12	1	¾	3,000	1,600
3½ x 10.....	1	¾ x 10	1	¾	2,000	1,700

24-4 UNLIGHTED SOUND BUOYS

24-4-1 Purpose—

A. Unlighted sound buoys are located in positions where a sound signal is desirable for night and foggy weather use, but where a lighted buoy is not considered justified. Gong buoys, as well as bell and whistle buoys, are used to provide a distinctive signal where there are several sound buoys in the immediate vicinity. Whistle buoys can only be used in open and exposed locations where a ground swell normally exists, as the whistle is sounded by air compressed in the pendulum tube by the motion of the sea.

24-4-5 Specific Standard Types—

A. *The 9-foot unlighted bell buoy (9B) (fig. 24-21) and the 9-foot gong buoy (9G) (fig. 24-22)* are unlighted sound buoys designed for use in deep, rough water, or in semi-exposed locations. The two buoys are identical in design except for the sound equipment.

(1) The upper portion consists of a three-legged steel tower designed so that the combination of daymark plates and gusset plates presents a good daymark. A standard 225-pound bell is used on the 9B buoy. The three gongs used on the gong buoy are 20 inches in diameter and weigh approximately 70, 80, and 85 pounds, respectively. The bell or the gongs are suspended from a well-braced plate on the three legs of the superstructure. Three tappers are hung from the top of the buoy.

(2) The buoy body is so designed that a rocking effect is created on the buoy by the slightest motion of the sea. The extreme maximum depth in which

these buoys can be moored is 30 fathoms, using 1¼-inch buoy chain. The minimum depth is 15 feet.

(3) See the table under section 24-4-15 for mooring appendages for all buoys in this section.

B. *The 8-foot unlighted bell buoy (8-B) (fig. 24-23) and the 8-foot gong buoy (8-G) (fig. 24-24)* are unlighted sound buoys designed for use in moderate depths of water and semi-exposed and protected locations where sound buoys without lights are required. The two buoys are identical in design except for the sound equipment.

(1) The upper portion consists of a three-legged steel tower designed so that the combination of daymark plates and gusset plates presents a good daymark. The bell on the 8B is a standard 225-pound bell. The three 20-inch diameter gongs on the 8G weigh approximately 70, 80, and 85 pounds respectively. The bell or the gongs are suspended from a well-braced plate on the three legs of the superstructure. Three tappers are hung from the top of the superstructure.

(2) The buoy is so designed that a rocking effect is created on the buoy by the slightest motion of the sea. The extreme maximum depth in which these buoys can be moored is 30 fathoms, using 1¼-inch buoy chain. The minimum depth is 15 feet.

C. *The 7W (fig. 24-25) whistle buoy* is an unlighted sound buoy designed for deep water and exposed locations where a sound signal without a light is required. The extreme maximum depth in which it can be moored is 50 fathoms, using 1¼-inch chain. The minimum depth is 30 feet. The buoy body and counterweight tube are similar to those on the standard lighted buoys, but the three-legged tower of the superstructure more nearly resembles that on the 9B and 8B buoys.

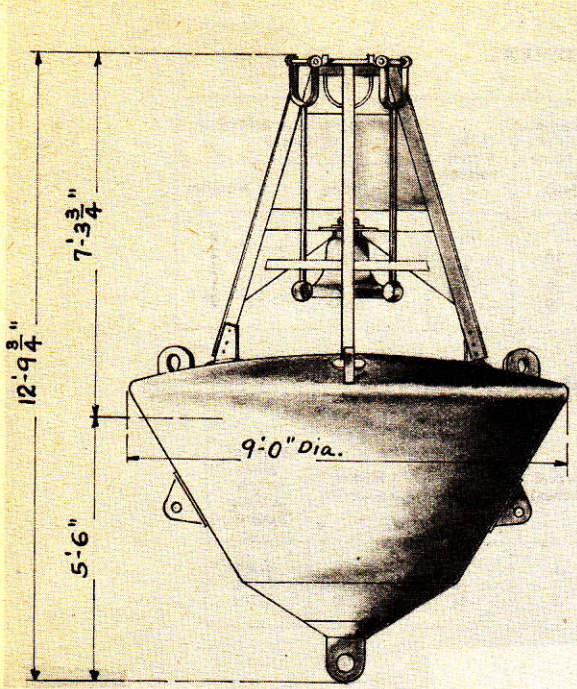

FIGURE 24-21.—9B unlighted bell buoy.

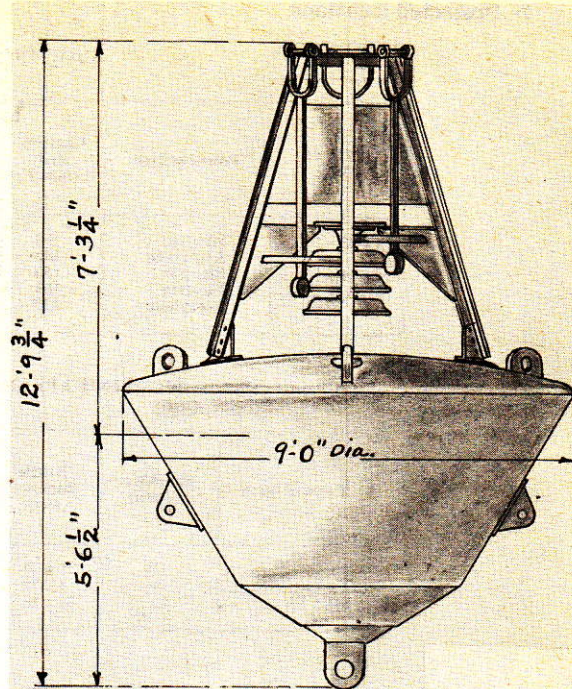

FIGURE 24-22.—9G unlighted gong buoy.

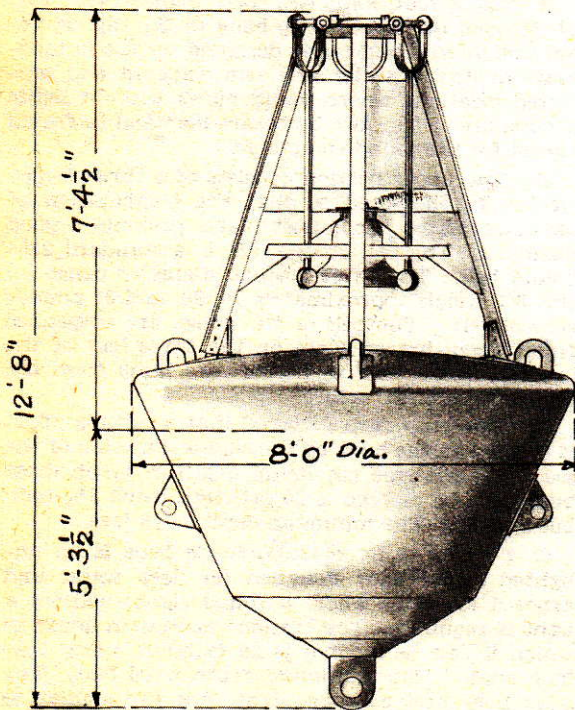

FIGURE 24-23.—8B unlighted bell buoy.

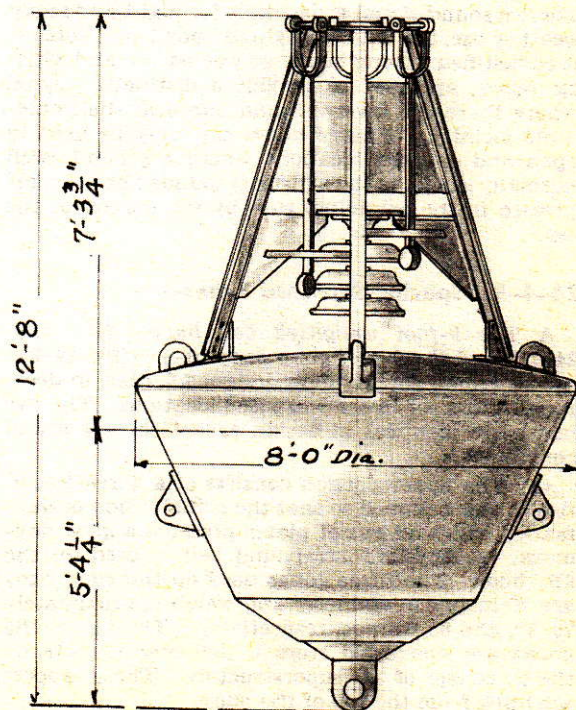

FIGURE 24-24.—8G unlighted gong buoy.

(1) The whistle and whistle valve (fig. 24-26) are of the two-ball type and differ from all other buoy whistles, which are of the 4-ball type. The whistle body and whistle valve are brass castings. The whistle bell, of 12-gage bronze 10 inches in diameter by about 18 inches long, is supported by a bronze spindle screwed to a valve casting, to which the whistle bell is riveted and soldered. The whistle valve contains two cork balls, each of which is 4 inches in diameter and weighs not more than 7¼ ounces. These balls are located between guides to

assure proper seating on the machine-surfaced valve seats. A standard 4-inch pipe extends from the valve and is welded to the top head of the buoy. The whistle tube is 24 inches inside diameter and extends 12½ feet below the top head.

(2) The whistle is operated by the up-and-down movement of the buoy in a seaway. The air in the whistle tube is compressed on the downward movement of the buoy and allowed to escape through a 1/32-inch aperture in the bell casting, blowing the whistle. On the upward movement the partial vacuum created in the whistle tube causes the balls to lift; air is again drawn into the tube, compressed on the downward movement of the buoy, and the operation is repeated.

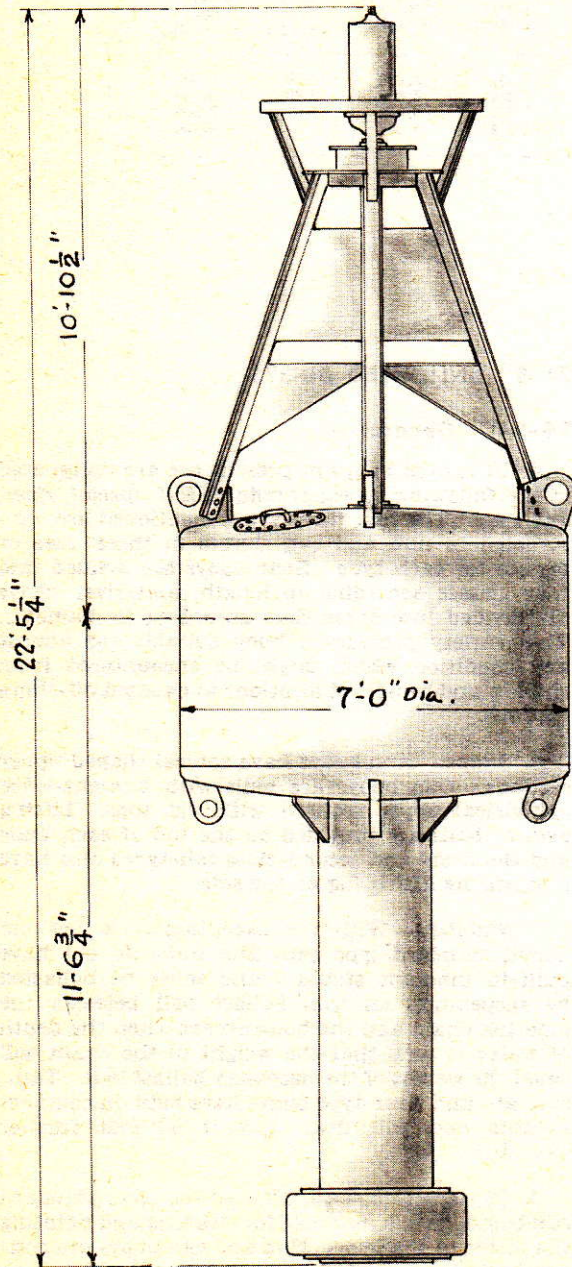

FIGURE 24-25.—7W unlighted whistle buoy.

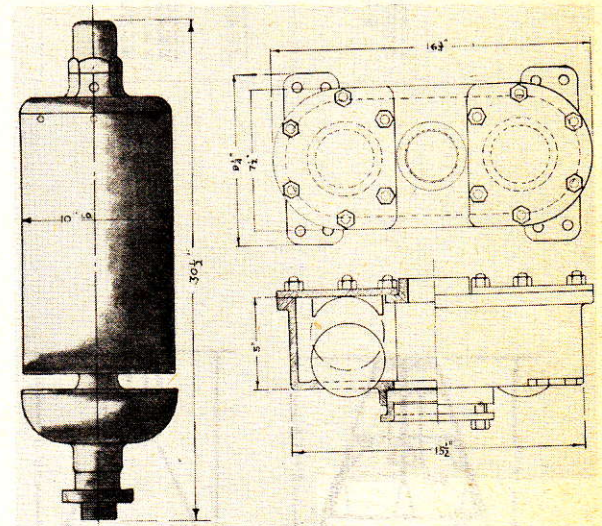

FIGURE 24-26.—Buoy whistle and valve (two ball).

24-4-10 Specific Nonstandard Types—

A. There are a few fixed-counterweight bell buoys (fig. 24-27) remaining in service. These buoys are similar to the 9B described under section 24-4-5 except that a hemispherical counterweight is built into the bottom of the buoy.

B. There are a number of obsolete 8W (fig. 24-27) whistle buoys remaining in service. This buoy has a nun-shaped upper body with an elliptical bottom into which a whistle tube is connected. Wooden fender strips are attached to the tube to prevent chafing by the bridle.

The whistle operates on the same principle as the whistle buoy described in paragraph 24-4-5 (C) and is protected by a cage on the top of the buoy. The buoy may be moored in water of not less than 30 feet nor more than 50 fathoms.

24-4-15 Mooring Appendages for all Unlighted Sound Buoys—

A. Following is a table of mooring appendages for standard and nonstandard unlighted sound buoys.

These values are only suggested for average conditions. The requirements of each individual location should be considered in selecting mooring appendages. See section 27-5-10 for further discussion on the selection of a mooring.

MOORING APPENDAGES AND WEIGHTS

Type of buoy	Shackle (inches)	Bridle (inches x feet)	Swivel (inches)	Chain (inches)	Sinker (pounds)	Ballast ball (pounds)	Weight of buoy (pounds)
9B/G.....	1¾	1¼ x 15.....	1½	1¼	5,000	2,600	6,300
8B/G.....	1¾	1¼ x 15.....	1½	1¼	5,000	2,600	5,600
7W.....	1¾	1¼ x 15.....	1½	1¼	5,000	—	7,000
8W.....	1¾	1¼ x 15.....	1½	1¼	5,000	—	6,500

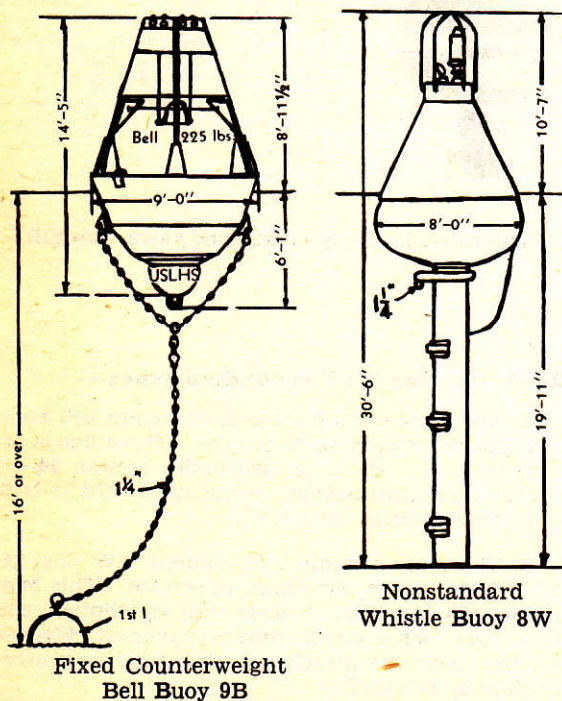

FIGURE 24-27.—Nonstandard unlighted bell and whistle buoys.

24-5 UNLIGHTED BUOYS

24-5-1 General—

A. Unlighted buoys in present use are designated in the following types; *standard, tall, special, river, and spar*. The first three types mentioned are constructed in nun and can shapes in three sizes or classes for each type. Spar buoys are divided into four classes according to length, and river buoys are divided into three sizes according to diameter. This variety provides a buoy suitable for almost any condition which might be encountered from shallow and protected locations to exposed off-shore stations.

B. *Shape*.—Nun buoys have conical shaped upper sections. Can buoys are built with straight-sided cylindrical upper sections with flat tops. Lifting eyes or balls are provided on the top of each buoy and the first- and second-class tall-types also have a balancing lifting lug on the side.

C. *Stability*.—With the exception of a few old buoys, standard-type cans and nuns do not have built-in inherent stability and must be ballasted by suspending an iron ballast ball between the mooring chain and the buoy except when the depth of water is such that the weight of the chain will equal the weight of the necessary ballast ball. Tall-, special-, and river-type buoys have built-in counterweights and will float upright without further ballasting.

D. *Construction*.—All tall, and the older standard can buoys, have a manhole for cleaning and painting the inside of the buoy. Nun and can buoys are constructed of soft steel plates rolled or dished to shape and welded to watertightness under 5 pounds hydrostatic or air pressure. Some older buoys are riveted.

E. *Marking.*—First- and second-class buoys are marked with 14-inch numbers, third-class buoys with 10-inch numbers.

F. *Spar buoys* are large wooden spruce, juniper, or cedar logs (some are now constructed of metal of similar shape and size) grouped in four classes of from 50 to 20 feet in length. They are usually fastened directly to the sinker or with a very short length of chain. A spar buoy rides best when one-third of its length is out of water.

G. *River-type nuns and cans* are small light-weight buoys designed for use in strong currents which would cause ordinary buoys to slide under.

H. Unlighted buoys do not ordinarily have bridles or swivels in their moorings.

24-5-5 Specific Types—

A. *Standard nuns and cans* (figs. 24-28 and 24-29) are designed for all depths and exposures (according to the limitations of each class). These buoys may be moored in moderate or deep water, and in sheltered or exposed locations where a good daymark is essential.

(1) When moored in shallow depths of water, a ballast ball is shackled to the bottom casting (except certain old buoys which have a built-in counterweight) to provide the necessary stability to keep the buoy floating upright. Where the weight of mooring chain in deep water will equal or exceed the weight of the ballast ball, it should be omitted.

(2) The table under paragraph (D) below gives maximum and minimum depths for these buoys, and normal recommended mooring appendages.

B. *Tall nuns and cans* (figs. 24-30 and 24-31) are designed for deep water and exposed locations where a good daymark is essential. The buoys are provided with manholes for access to the interior.

C. *Special nuns and cans* (figs. 24-32 and 24-33) are designed for shallow or moderately deep water in sheltered or semi-exposed locations, and in moderate currents in inland waterways. These buoys have replaced the wooden spars on many locations because they withstand damage from ice, logs, and debris. Special-type buoys do not have manholes and are not painted on the inside. A gallon of black oil may be poured inside and the buoy rolled around to protect the interior surfaces against corrosion.

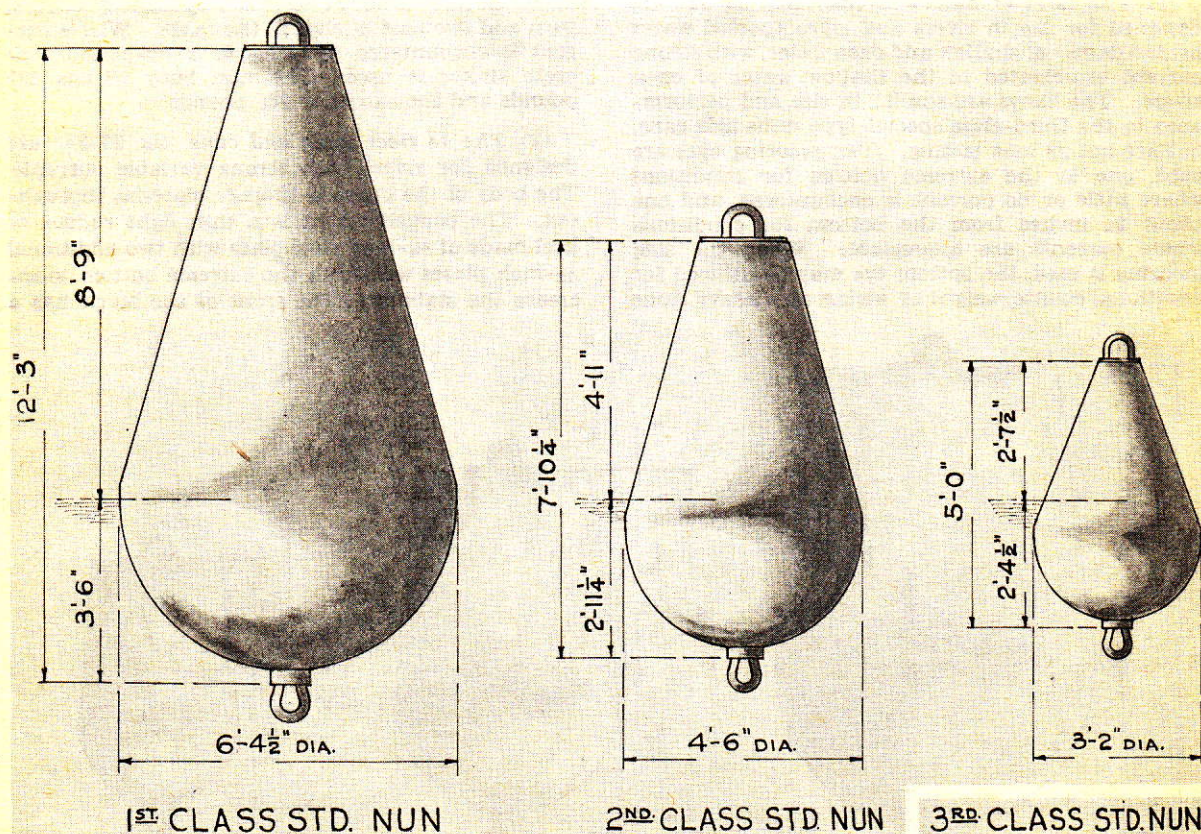

FIGURE 24-28.—Standard-type unlighted nun buoys.

D. Following is a table of appendage data for standard-, tall-, and special-type buoys.

MOORING APPENDAGES AND WEIGHTS

Type of buoy	Depth of water		Resulting freeboard at maximum depth (inches)	Ballast ball (pounds)	Shackles (inches)	Chain (inches)	Sinker (pounds)	Weight of buoy (pounds)
	Minimum (feet)	Maximum (fathoms)						
Standard Nun, first class.....	14	85	50	1,260	1 3/4	1 1/4	5,000	2,710
Standard Nun, second class.....	12	45	33	410	1 1/2	7/8	4,000	1,355
Standard Nun, third class.....	8	15	19	120	1	3/4	3,000	515
Standard Can, first class.....	14	85	33	1,260	1 3/4	1 1/4	5,000	2,920
Standard Can, second class.....	12	45	28	410	1 1/2	7/8	4,000	1,485
Standard Can, third class.....	8	20	19	120	1	3/4	3,000	705
Tall Nun, first class.....	25	120	68	-----	1 3/4	1 1/4	5,000	6,435
Tall Nun, second class.....	22	100	54	-----	1 1/2	1	4,000	4,520
Tall Nun, third class.....	15	70	36	-----	1 1/2	7/8 or 1	3,000	2,260
Tall Can, first class.....	25	100	60	-----	1 3/4	1 1/4	5,000	6,925
Tall Can, second class.....	22	75	48	-----	1 1/2	1	4,000	4,580
Tall Can, third class.....	15	55	36	-----	1 1/2	7/8 or 1	3,000	2,355
Special Nun, first class.....	18	22	48	-----	1 1/2	1 1/8	4,000	2,035
Special Nun, second class.....	15	16	34	-----	1 1/2	1	3,000	995
Special Nun, third class.....	12	14	24	-----	1	3/4	2,000	665
Special Can, first class.....	18	22	36	-----	1 1/2	1 1/8	4,000	2,090
Special Can, second class.....	15	16	18	-----	1 1/2	1	3,000	1,010
Special Can, third class.....	12	14	15	-----	1	3/4	2,000	680

E. River type.—Three types of lightweight special-service buoys for marking rivers and other inland waterways have been designated standard. The 19-, 18-, and 15-inch diameter buoys are so designated without the inch symbol.

(1) The 19 river nuns and cans (fig. 24-34) are designed for use in rivers and lakes (pooled water behind dams) of shallow and deep water, with strong current anticipated in the shallow water of open rivers. The buoys are similar in size and performance to the third-class special-type nuns and cans, but are not as long lasting. Two mooring eyes are used, one at the extreme bottom for conditions where little or no current is encountered, and one about 24 inches from the bottom for conditions where currents are appreciable. When the side mooring is used, the bottom eye may be utilized for additional counterweight by wiring on a heavy stone

or slab of concrete. The general practice is to moor these buoys with one or more 25-foot pieces of 5/8-inch chain and two 1-inch shackles, one for each mooring eye. As an expedient in still water, mooring may be effected with 3/8-inch galvanized strand cable attached to both buoy and sinker by making a round turn and two half hitches in the cable. Where current is encountered, a 1,000- or 2,000-pound concrete sinker is used. The nun buoy weighs 245 pounds and the can buoy 265 pounds.

(2) The 18 river nuns and cans (fig. 23-34) are designed for rivers with strong variable currents. The body of the buoys is 18-gage material throughout. The counterweight is a thin light rudder or keel made of 1/4-inch steel plate with two additional 1/2-inch plates welded to the extreme bottom to increase the stability. The front of the buoys has a

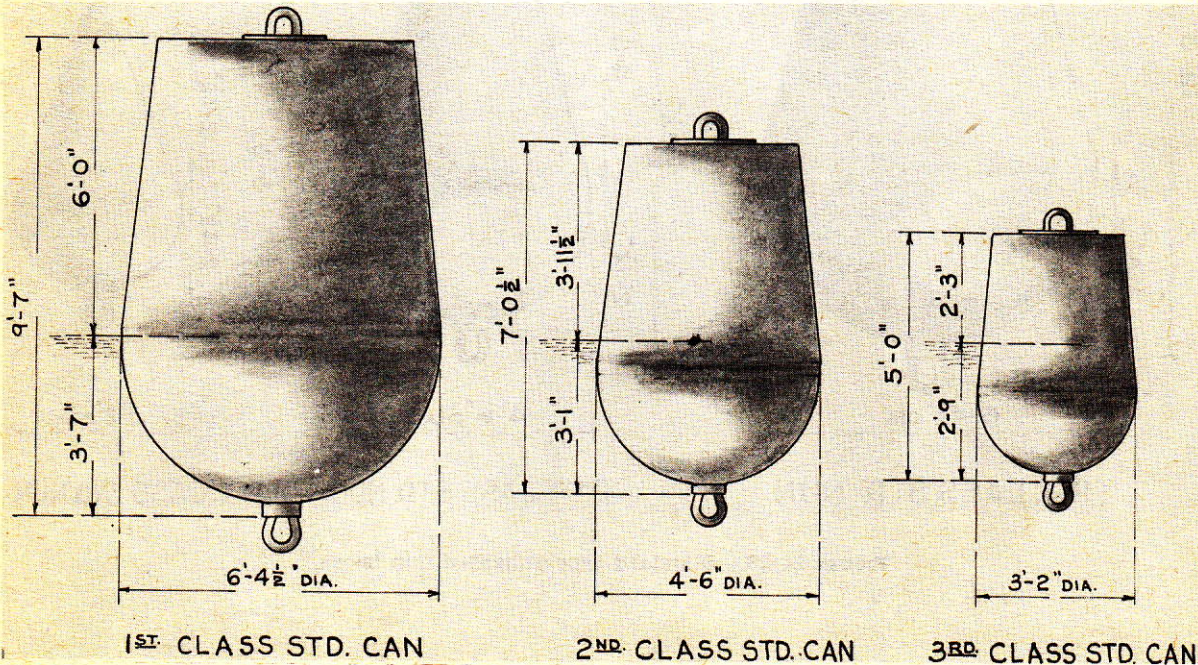

FIGURE 24-29.—Standard-type unlighted can buoys.

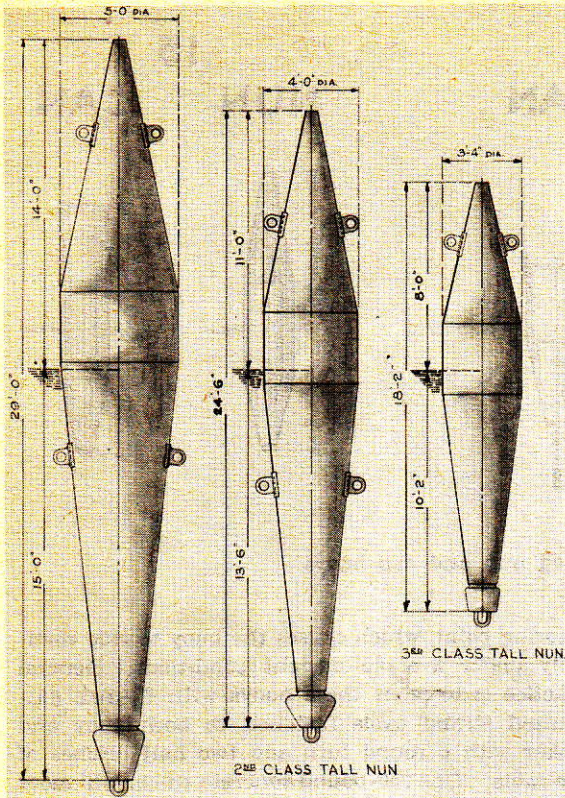

FIGURE 24-30.—Tall-type unlighted nun buoys.

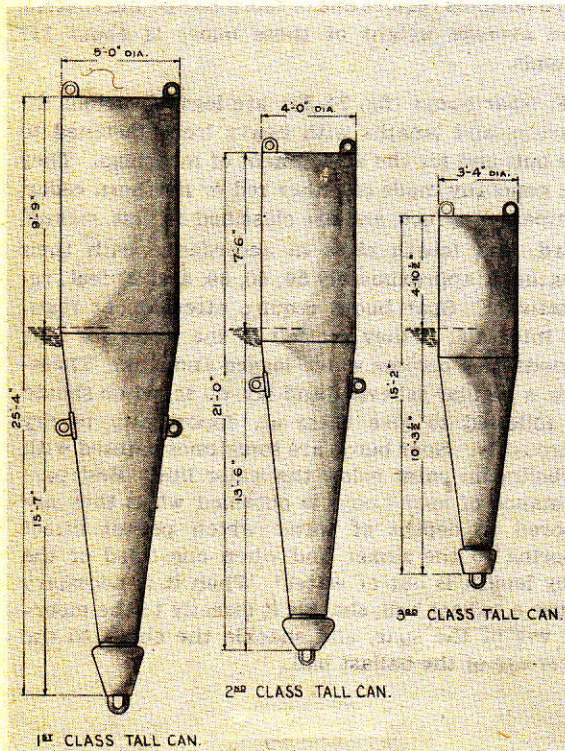

FIGURE 24-31.—Tall-type unlighted can buoys.

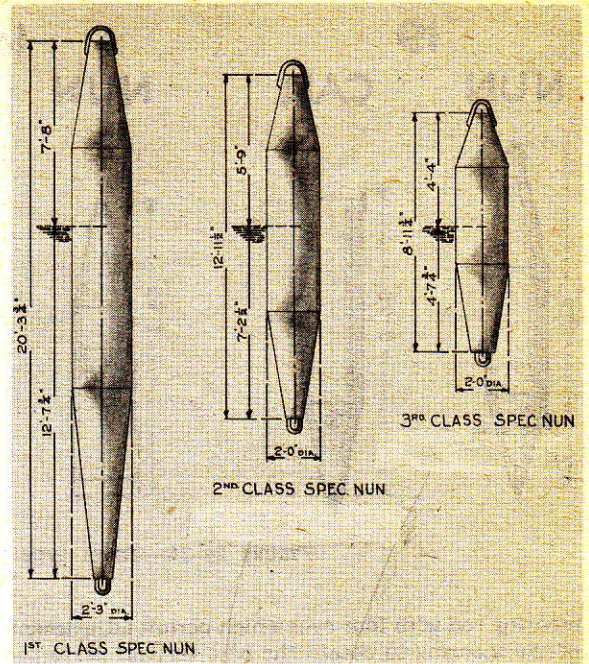

FIGURE 24-32.—Special-type unlighted nun buoys.

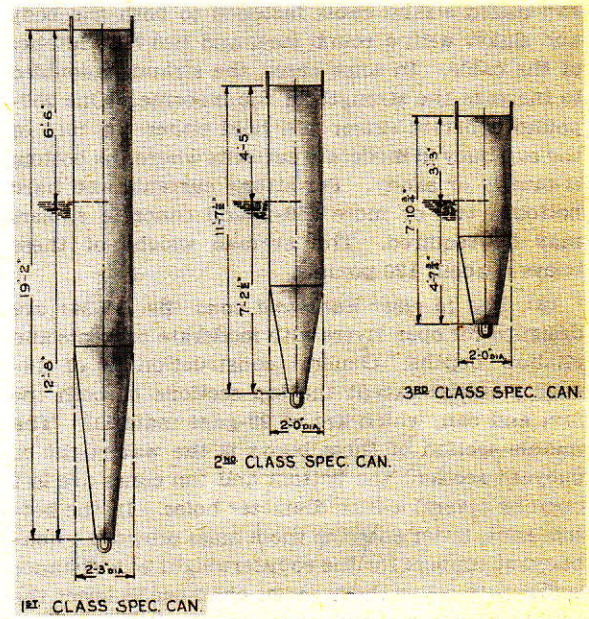

FIGURE 24-33.—Special-type unlighted can buoys.

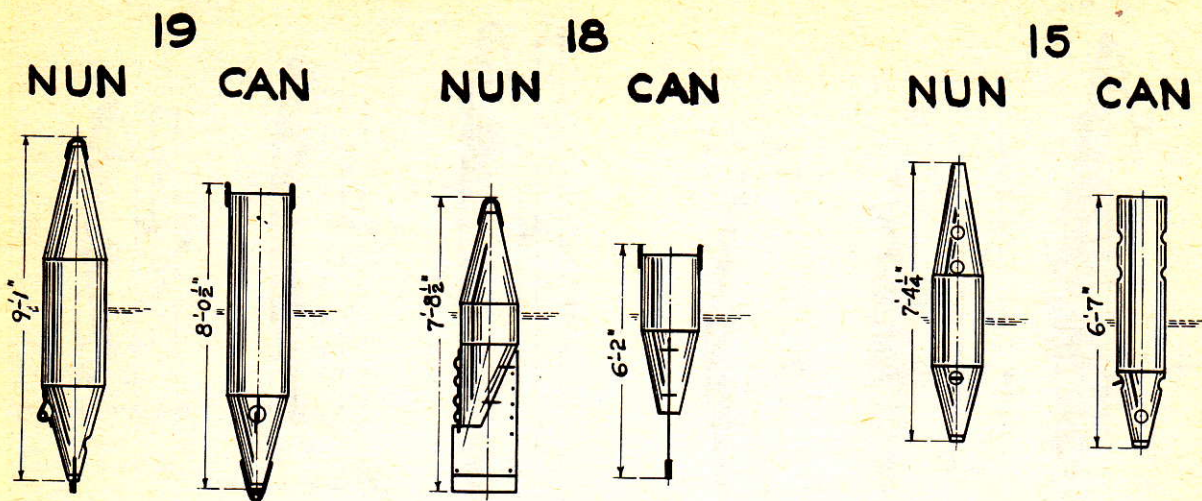

FIGURE 24-34.—River-type unlighted nun and can buoys.

mooring rod with four eyes which permit adjustment of the mooring to obtain the best vertical performance of the buoy in the current at a given location. These buoys are generally moored with $\frac{3}{8}$ -inch galvanized strand cable fastened to both the body and sinker with a round turn and two half hitches of the cable. In some cases, the strand is doubled to increase the strength of the mooring. One 250-pound concrete sinker will hold either the nun or the can buoy in moderate currents where the bottom is muddy or sandy. For strong currents and hard bottoms, two or more 250-pound concrete sinkers may be required. The average weight of these buoys is about 120 pounds.

(3) *The 15 river nuns and cans* (fig. 24-34) are designed for open rivers with moderate currents and shallow depths. General construction is of 16-gage material except the top sections of both the nun and can, which are of 20-gage material. The middle section of these buoys is the watertight or buoyant section; the bottom and top cones are left open by several 4-inch diameter holes. In the bottom cone, water entering these holes provides a non-buoyant support for the counterweight at a distance sufficiently below the buoyant chamber to lower the center of gravity and thus increase the stability. In the nun cone, the top holes are reinforced at the top edge to serve as lifting holes. In both shapes, holes in the top provide access for installation of reflector buttons. Thirty-six $\frac{7}{8}$ -inch diameter reflector buttons may be installed in either nun or can top with facility. These buoys have a single

mooring point, which causes the buoy to ride vertically under average current conditions. General practice is to moor these buoys with $\frac{3}{8}$ -inch galvanized strand cable fastened to both buoy and sinker with a round turn and two half hitches of the cable. One 250-pound concrete sinker will moor either buoy in moderate currents where the river bottom is muddy or sandy. Strong currents and hard bottoms require one or more 250-pound sinkers. The average weight of these buoys is about 117 pounds.

F. *Spar buoys* (fig. 24-35) are logs of various diameters and lengths with heavy irons fastened to the butt end for the attachment of moorings. They are generally made of either red or northern cedar, juniper, or spruce, and are classified as first, second, third, and fourth class in accordance with their lengths of approximately 50, 40, 30, and 20 feet, respectively. Spar buoys require attention at regular intervals; if they are left in the water for long periods they become water-logged and sink. Therefore, a regular relieving and lay-up schedule should be followed to give them an opportunity to dry thoroughly. Spar buoys are sometimes painted with carbolineum paint below the water line. Best performance of spar buoys is obtained when they are moored in depths of water which permit direct mooring to the sinker and when one-third of the buoy length is out of water. When it is necessary to use a ballast ball, shackle it directly to the mooring eye of the spar, and shackle the chain to the lower eye of the ballast ball.

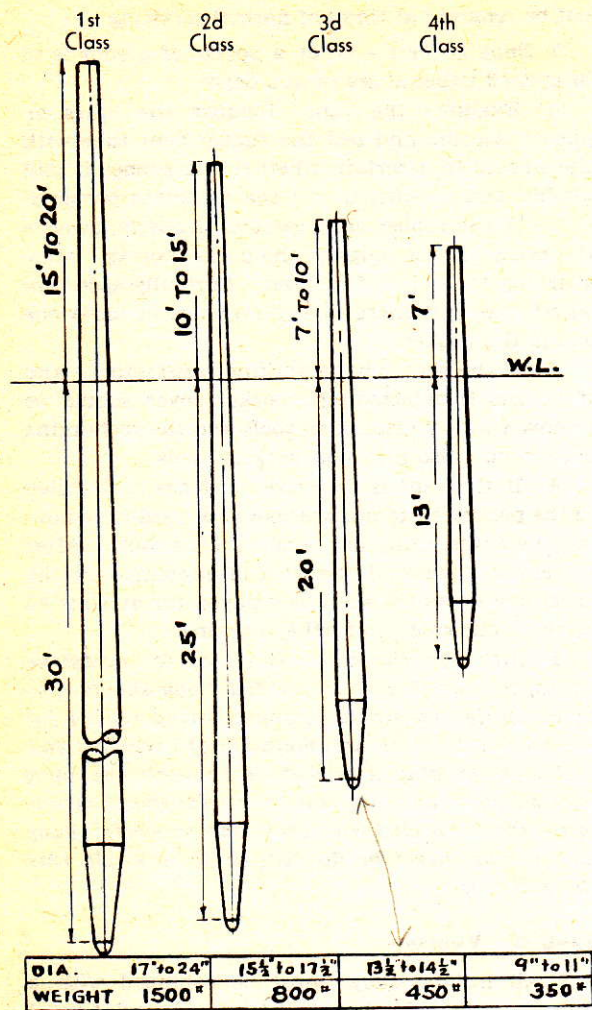

FIGURE 24-35.—Wooden spar buoys.

(1) *The 1st class spar* is 50 feet in length and is generally moored directly to a 4,000-pound concrete sinker. In depths greater than 5 fathoms, a ballast ball and 1/4-inch chain are used. The first-class spar is from 17 to 24 inches in diameter and weighs about 1,500 lbs.

(2) *2d class spar*—This buoy is 40 feet long, 15 inches to 17 inches in diameter, weighs about 800 pounds and is usually moored to a 3,000-pound concrete sinker.

(3) *3d class spar*—This buoy is 30 feet long, 13 inches to 14 inches diameter, weighs about 450 pounds and is usually moored to a 2,000-pound concrete sinker.

(4) *4th class spar*—This buoy is 20 feet long, 9 inches to 11 inches diameter, weighs about 350 pounds and is usually moored to a 1,000-pound concrete sinker.

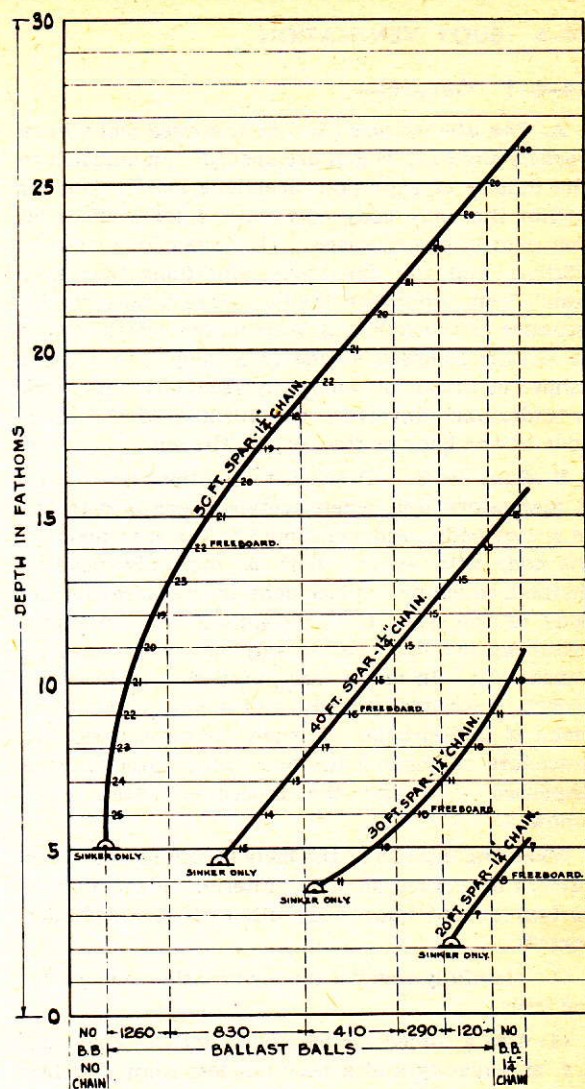

FIGURE 24-36.—Table of moorings for spar buoys.

(5) The primary purpose of the chart (fig. 24-36) is to assist in the proper selection of a spar buoy under various conditions. Since the depth of water and size of spar buoy are generally the controlling factors, the chart has been prepared with these factors in mind. For example: What size spar buoy should be used in 10 fathoms of water? Refer to the chart (fig. 24-36) opposite the 10 fathom line. Any of the following may be used.

(a) 50-foot spar with 21 feet of freeboard, 1/4-inch chain 1,260-pound ballast ball.

(b) 40-foot spar with 15 feet of freeboard, 1/4-inch chain, 410-pound ballast ball.

(c) 30-foot spar with 10 feet of freeboard, 1/4-inch chain, no ballast ball.

24-6 BUOY VENTILATION

24-6-1 General—

A. *The utmost care shall be exercised when buoy pockets and buoy bodies are opened.* In addition to the danger of explosion, acetylene gas or foul air within the buoy body may have a toxic effect on men sent into such space. The importance of ventilation, and the dangerous conditions that may result from ignorance thereof, have prompted the issuance of the following instructions which should be strictly followed whenever a buoy is recharged ashore or afloat, or when any reconditioning work is undertaken involving the opening of the main body of the buoy or the pockets thereof.

B. *Buoy bodies.*—Previous instructions have made it mandatory that when acetylene gas is detected in a buoy body, recourse should be taken to flooding the body with water. This is the only positive method, which by displacement, insures clearing the body of the gas. It is recognized that in many instances, flooding a buoy body with water may be impractical. In many cases, even though the procedure is possible, the cost and inconvenience may make it undesirable. In such circumstances, the procedure of flooding the buoy with water may be dispensed with and the procedures listed below followed:

When the interior of the body of any buoy is to be entered or worked on: (By "interior" is meant any portion of the buoy body other than a cylinder pocket).

(1) Carefully remove the cover, using nonsparking tools.

(2) Use a forced air blower of not less than 250 c. f. m. capacity and a hose not less than 2 inches in diameter to change the air inside the buoy. This hose may be of any *nonmetallic* material and should have a rubber connection or vulcanized section on both ends as a protection against sparking. Where a depot has compressed air facilities meeting the above requirements and is accustomed to using them for changing the air within the buoy body, the continued use of such facilities, in lieu of purchasing new blower equipment, is approved.

(3) After not less than one-quarter hour has elapsed, the workman may be permitted to enter the buoy, and the blower kept in operation.

(4) A reliable helper should stand outside near the entrance to keep watch on the man inside, to maintain communication, and to operate the blower.

C. *When to enter buoy.*—All types of buoys now approved for use no longer require inspection of the interior of the body except in the event of damage due to collision or similar cause. Unless there is some definite reason to indicate that some work on

the interior is required, the manhole cover should not be removed at times of normal servicing.

D. *Buoy pockets.*—When a pocket of a buoy is to be opened either at sea or at a depot:

(1) Examine the vent. Remove the brass or plastic housing and test the rubber vent tube with the fingers to ascertain whether the rubber is still pliable, and whether or not the slit opens properly.

(2) If the rubber vent operates properly, remove the brass plug or plugs in the pocket covers. Non-sparking tools should be used. Carefully ascertain whether or not there is any evidence of acetylene gas in the pocket.

(3) If the vent tube is working satisfactorily and if no gas is detected, the pocket cover should be removed with nonsparking tools and the recharging carried out, also with nonsparking tools.

(4) If the vent is defective or if gas is detected in the pocket, extreme care should be used in removing the cover, using only nonsparking tools. After the cover is removed, the work of disconnecting the acetylene cylinders shall be delayed for at least 30 minutes allowing for further purging.

(5) *Although the above is stated for acetylene buoys, the opening of an electric buoy should also be carefully and similarly done, having regard for the possibility of an accumulation of hydrogen gas. Although flooding a pocket of an acetylene buoy does no harm and is a positive displacement means of freeing the pocket from acetylene, an electric buoy pocket must never be flooded; to do so would ruin the batteries.*

24-6-5 Vents—

A. All lighted buoys must be equipped with a vent or safety valve to prevent the accumulation of gas pressure inside pockets and buoy bodies. The vent (fig. 24-37) which is enclosed in a brass or plastic housing, consists of a rubber tube with a slit cut in its side. The rubber tube is closed at one end and open to the buoy tubing on the other. It will not support much over one-half pound per square-inch pressure and will bleed pressure starting at one one-thousandth pound.

B. *Size of vent piping.*—The piping, which is of $\frac{1}{4}$ inch O. D. brass, having a wall thickness of $\frac{1}{16}$ inch, has compression fittings on each end for attaching to the vent housing and buoy vent connection.

C. *Interior connection (staybolt).*—For venting acetylene cylinder pockets, it is necessary to have a watertight interior connection (fig. 24-38) leading from the pocket through the buoy head. To avoid the possibility of confusion with the gas piping, the inside end of this fitting is not threaded. The electric buoy vent interior connection is similar to the acetylene.

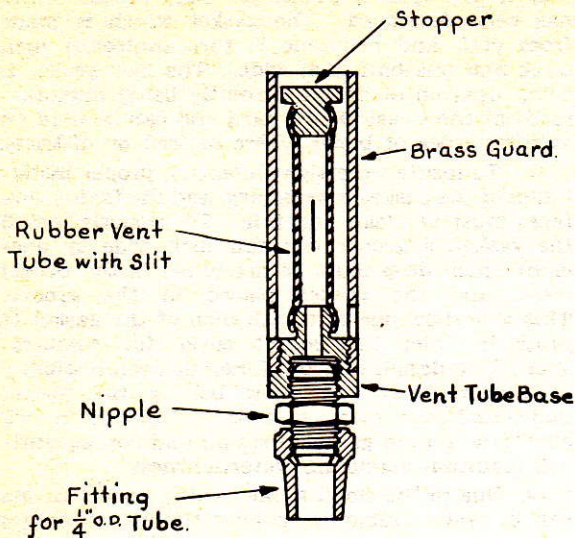

FIGURE 24-37.—Buoy vent tube.

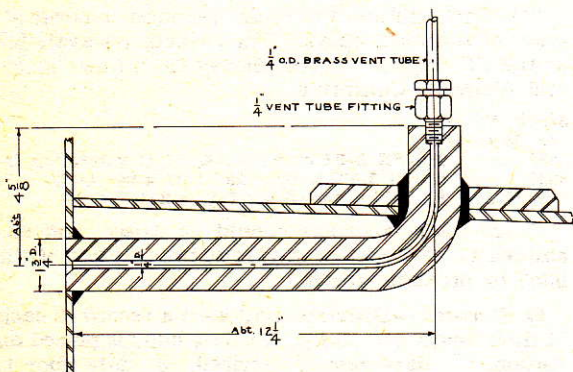

FIGURE 24-38.—Interior vent connection.

D. *Arrangement of pipes.*—Vent pipes run up the inside of the tower leg to the underside of the lantern platform with the vent end bent downward in a half loop. (See fig. 24-39.)

E. *Procurement.*—Vents are furnished with the buoy by the manufacturer. Additional vents may be obtained from the manufacturer or may be fabricated in the district machine shop.

24-6-10 Conversion of Acetylene Buoys to Electric—

A. Acetylene buoys can be converted readily to electric by replacing interior acetylene connections (staybolts) with interior electric connections. (See Chapter 21, "Electric Apparatus" for details of new steel elbow now used in lieu of interior electric connections and junction boxes in the pockets of new buoys.

B. For safety reasons, Headquarters will not authorize the conversion of an electric buoy to acetylene.

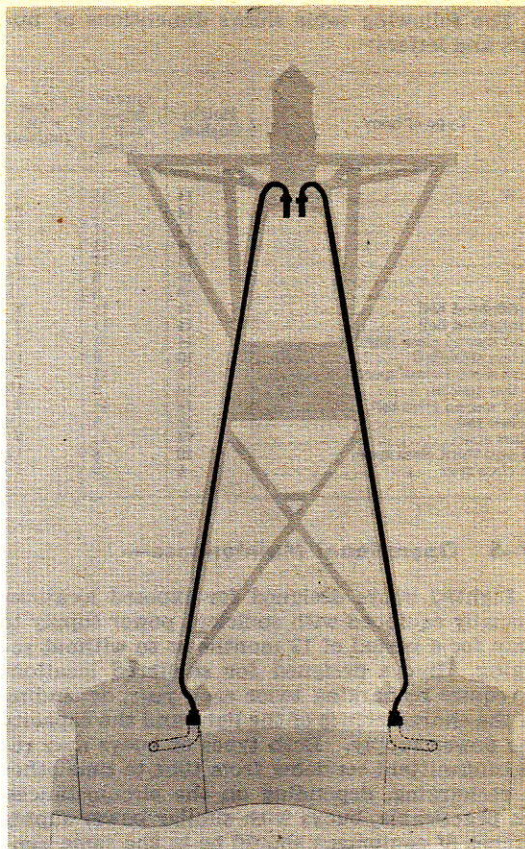

FIGURE 24-39.—Typical buoy vent piping arrangement.

24-7 BUOY MAINTENANCE

24-7-1 Painting—

A. Because of the rapid development of improved painting systems and the need for special techniques for their application, the subject will not be treated in this chapter. See the Painting Instructions Memorandum series of directives for details relative to painting buoys.

24-7-2 Identifying Markings—

A. Buoys and certain minor lights are marked by letters or numbers, depending on their characteristic and significance to the mariner. These characters are painted on each side of the daymark of buoys with superstructures and on two opposite sides of other types of buoys and minor structures. White numerals or letters are used on black or red backgrounds, and characters used on white background are black on buoys and red or black on structures. These numerals and letters are four squares wide and five squares high except the letters I, W, and M. Use block letters and numerals in accordance with the dimensions shown below. Use standard stencils and make solid characters in all cases.

B. The following table shows dimensions of numerals and letters:

Type of buoy	Height (inches)	Approximate width (inches)	Line width (inches)
10 x 39-W	14	11	2
9 x 32	14	11	2
8 x 26	14	11	2
6 x 20	14	11	2
7-FE	14	11	2
5-FE	10	8	1½
3½-FE	10	8	1½
9-foot unlighted bell	14	11	2
8-foot unlighted bell	14	11	2
First and second class standard	14	11	2
Third class standard	10	8	1½
First and second class special	14	11	2
Third class special	10	8	1½
First and second class tall	14	11	2
Third class tall	10	8	1½
First class spar	14	11	2
Second and third class spars	10	8	1½
Fourth class spar	6	5	1

24-7-5 Operational Maintenance—

A. Lighted buoys designed for exposed locations are usually equipped with sufficient power supply to operate for a period of 12 months or so without recharging. Buoys designed for sheltered locations may require recharging twice each year, depending upon the characteristic of the light and the capacity of the power supply. Both types of buoys may require intermittent servicing from time to time other than recharging, depending on the circumstances. When practicable, buoys with similar power supply and types of equipment should be in the same general area to obviate the need for carrying several different types of battery racks, cylinders, lanterns, etc., on board the tender.

B. *Service (operational maintenance) and relief.*—All buoys shall be serviced as often as necessary, and in any event at least once each year. Vinyl-painted buoys shall normally be relieved once every 2 years; other buoys, once each year as heretofore. This shall not preclude the relief of a buoy at more frequent intervals due to special circumstances.

C. *Buoys not in service* shall be kept clean, repaired, painted, and ready for service.

D. *Gaskets for manhole and pocket covers* on older buoys are made of rubber, three-sixteenths inch thick. They are full width of the flange. Holes and slots for cap screws and bolts are kept to the minimum allowable tolerance suitable for the pitch of the bolt circle. The faces of the gasket in contact with steel surfaces are treated with graphite before replacing the cover. For new buoys, see paragraph (E) below.

When the pockets of a buoy are open for recharging, a new gasket should be used if the old one is wrinkled, torn, hardened, out-of-shape, or in any way not suitable for a watertight joint. Gaskets on lanterns and watertight connections should also be replaced when they appear unfit to insure watertightness.

E. A new type of gasket for buoy pocket covers has been developed. The gasket which is made from cork and neoprene is three-sixteenth inch thick and one-half inch wide. The new gasket is being used on all buoys currently being manufactured at the Coast Guard yard and can be used on existing types of buoys where desired by districts.

(1) To insure watertight integrity, proper installation of the gasket is necessary, and the faying surfaces must be clean and fair. To properly install the gasket, a groove one-half inch wide by one-eighth inch deep must be machined in the pocket cover and the gasket placed in the groove. This will allow one-sixteenth inch of the gasket to protrude from the pocket cover for compression. The design and the inherent compressibility of the material will allow bolting the pocket flange and cover metal-to-metal. This feature will eliminate uneven gasket pressure and consequently will maintain maximum watertightness.

(2) Due to the small gasket width, pocket covers can be readily removed without the use of wedges or heavy tools, and since the gasket is relatively inexpensive it should be replaced each time the pocket cover plate has to be removed from the buoy.

(3) Three different sizes are required to cover all types of standard buoys. The gaskets are available at the CG Supply Centers, Jersey City, New Jersey, and Alameda, California.

Stock Nos.

CG 33-G-1317

8880----- 3½-FE, 5-FE buoys—21¾" I. D. x 22¾" O. D.
8930----- 6 x 20, 7-FE buoys—23" I. D. x 24" O. D.
8980----- 8' x 9' buoys—25½" I. D. x 26½" O. D.

F. *All buoy moorings* should be raised and examined at least once each year to prevent loss of the buoy by breaking adrift.

G. *Records.*—Districts shall keep a record of each of their buoys, recording: (1) date buoy is placed on station, (2) date buoy is serviced, (3) date buoy is relieved, etc.

H. *Complete servicing instructions* relative to lighting equipment will be found in Chapter 20, "Acetylene Apparatus," and Chapter 21, "Electric Apparatus" of this manual. Proven methods of the actual handling of buoys on board tenders, relieving, launching and recovering, etc., will be found in Chapter 27, "Aids to Navigation Seamanship."

24-7-10 Structural Repairs of Buoys—

A. Buoys are frequently in need of repair after a period on station. As a result of collision, the superstructure becomes broken or twisted, the body is dented or punctured, and in the case of sound buoys, the bell stand may be damaged to the extent of silencing the signal.

B. Buoys are normally repaired at depots. However, a tender or other unit may occasionally be required to effect minor structural repairs.

C. *Small dents* in the main body of the buoy are not serious and may be allowed to remain. However, if they are adjacent to a welded or riveted seam, the buoy body should be subjected to an air test as described under paragraph (H) below.

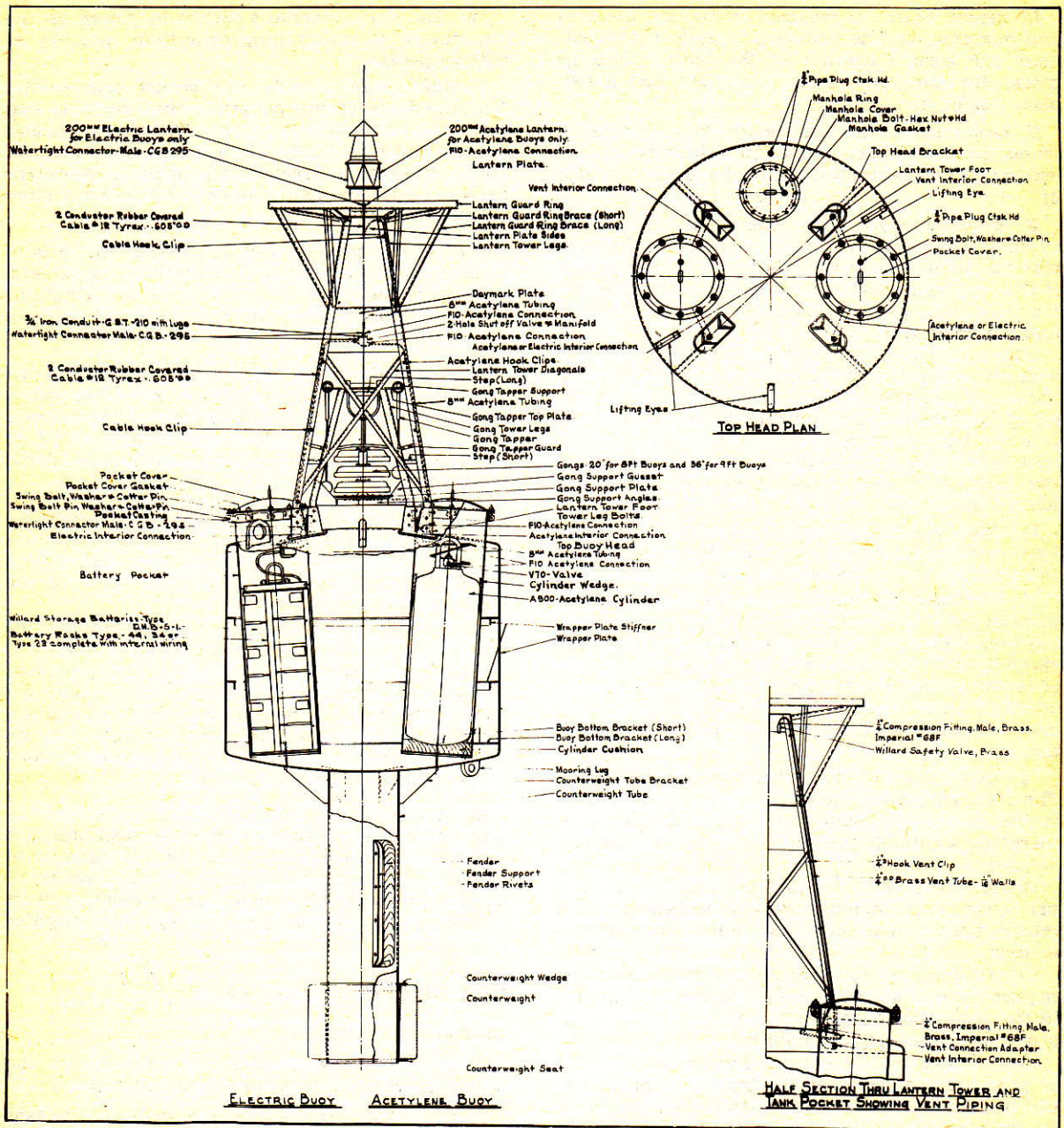

FIGURE 24-39A.—Nomenclature of parts of a lighted buoy.

D. *Severe dents* are repaired by heating the area and bumping out the damaged section to approximate the normal contour of the buoy. In some cases, the damaged section is cut out and a new plate welded in.

E. *Leaks in seams*.—In riveted buoys, leaks in seams may be caulked tight. In welded buoys, the leaking section is chipped out V-shape and welded up.

F. *Manhole cover*.—The buoy body is entered through a manhole in the buoy head. When replacing the manhole cover, renew the rubber gasket if it is not in perfect condition. Be sure that the manhole studs are in good condition and that the nuts screw on freely.

Buoys currently being manufactured are made without removable manhole covers. An access opening is provided in some buoys during the process of fabrication. This opening is welded shut before the buoy is completed. In cases where entry into such a buoy is required, chip the weld from the cover plate and reweld it in place when the job is completed.

G. *Caution*.—Do not use an acetylene burning torch inside a buoy body. A slight leak in the torch valve or line can easily result in an explosion.

H. *Testing buoy body*.—After the necessary repairs to the buoy body are complete and the interior has been cleaned out and painted with red lead, the manhole cover is made up tight (welded in the case of recently-built buoys) and the body subjected to an air or water pressure test of 5 pounds per square inch. Plugged test connections will be found in the top of the buoy head.

(1) *Caution*.—Testing with air can be dangerous. The usual air pressure available in shops and depots is often about 100 pounds per square inch or more, therefore, a suitable pressure reducing valve should be used.

(2) A safety valve set to blow off at 10 pounds per square inch should always be installed, and a reliable pressure gage of 0 to 50 pounds range should be used.

(3) *Shut-off valves* in the air line to the buoy are required and as an extra safety factor, the air line to the buoy should be disconnected as soon as the proper pressure has been built up.

(4) *Battery pockets* should be tested at the time of periodical servicing of the buoy. A test outlet will be found in each of the battery pocket covers. Be sure to remove the vent piping and watertight cable connectors and replace them with plugs.

(5) Go over the joints with a liberal amount of soapsuds. Five pounds per square inch is sufficient pressure for testing and should not be exceeded.

I. *Inspection of pocket covers and gaskets*.—The faces of both pocket covers and cover castings become pitted and irregular due to rust and should be inspected as frequently as possible. It is better to renew a gasket that looks just good enough, than to take a chance.

(1) Particularly in the case of electric buoys, pocket covers with scaled or uneven surfaces should be removed and refaced, or renewed if necessary. This involves burning the casting from the pocket tube and rewelding.

(2) Too much emphasis cannot be placed on the importance of maintaining watertight integrity of battery pockets.

J. *Making up gaskets and pocket covers*.—See that the faces of the pocket covers, castings, and gaskets are smooth and clean. All swing bolts and nuts should turn freely. If using old-type gaskets, apply dry graphite freely to all surfaces. *New-type neoprene gaskets require no grease or other sealing compound.*

A satisfactory method of applying graphite is to place an inch or so of it in a small container and pour in enough water to just cover the graphite; using a piece of waste or rag, swab all surfaces thoroughly.

K. *Removal of lantern during repairs*.—When hammering, chipping, scaling, or repairing buoys, remove the lantern. Otherwise the shock from these operations is transmitted to the lantern and may damage the flasher mechanism and break the colored shade or lens.

L. *Damaged watertight connections*.—In some locations where driftwood or ice is prevalent, electric cable watertight connections and vent connections are damaged, resulting in water leaking into the buoy battery pocket.

In the case of electric cable and watertight connections, a 3/4-inch galvanized pipe may be used to replace the connection. A short nipple and union coming out of the staybolt in the buoy head connects to the pipe which is bent as necessary to conform with the angle of the tower legs and runs well up into the daymark. Reinstall the watertight connector on the top end of the pipe.

M. *Mooring lugs*.—In some of the larger riveted-type buoys, the mooring lugs contain steel bushings which may be replaced when they become worn through. In mooring lugs which are not so provided, worn spots may be built up by electric welding. This also applies to bottom mooring eyes on unlighted buoys.

24-8 BUOY PROCUREMENT

24-8-1 Requisitions—

A. All buoys (except river type for use in the Second District) shall be procured on requisition.

B. Requisitions for buoys and mooring appendages for which district funds are available, shall be submitted to the Commanding Officer, Coast Guard Yard, Curtis Bay, Md., and the Coast Guard Supply Center, Jersey City, N. J., respectively, in accordance with ~~Pay and Supply Instructions Article 1041-(1)~~ (a) and (b) *the Comptroller Manual*

24-8-5 Relief Buoys—

A. Complete spare buoys with mooring appendages shall be kept on hand to accomplish the relief of buoys on station and to temporarily mark sunken wrecks. ~~The quantity of spare equipment shall be that which can most efficiently meet the needs of relief. Normally, it shall not be more than 25 percent of buoys and equipment on station.~~ *The quantity of spare buoys shall be maintained in accordance with the district allowance of buoy stocks.*

24-8-10 Equipment on Term Contract—

A. Acetylene piping, fittings, cylinders, gages, lanterns (both electric and acetylene), batteries, battery racks, vents, gaskets, and repair parts for any buoy equipment may be purchased direct from contractor when on term contract if not available from the Coast Guard Supply Center.

24-9 MOORING APPENDAGES

24-9-1 Component Parts—

A. Standard buoy appendages consist of the following various parts essential for mooring buoys:

- (1) Open-link iron or steel buoy chain.
- (2) Chain bridles.
- (3) Shackles.
- (4) Swivels.
- (5) Sinkers.
- (6) Ballast balls.

B. Each of the above appendages is described and illustrated below.

24-9-5 Buoy Chain—

A. This was formerly open-link wrought iron chain, usually furnished in 15-fathom shots with

end links of larger dimensions for shackling to the buoy or other appendages. Steel open-link chain is now being purchased. Buoy chain is available in diameters of 1/2 to 1 7/8 inches. The over-all length of the link is approximately six times the wire diameter, and the width of the link is 3 1/2 times the diameter. See figure 24-40 for exact dimensions.

B. The scope of chain used to moor a buoy may vary from 1 1/2 to four times the depth, dependent upon conditions of exposure, type of bottom, location relative to desired radius of swing, etc. Determination of this figure generally rests on the experience of qualified tender personnel. See section 27-5-10 for further discussion on the selection of a mooring.

C. The size of chain to be used depends not only on the strength of the chain when new, but on the fact that in certain rocky and sandy bottoms, a few links of that part of the chain which rises and falls with the buoy in a seaway and drags over the bottom (known as the "chafe"), may wear out rapidly. Chain worn to less than one-third its original diameter in less than a year is commonly found. This shot of chain may be repaired by cutting out and replacing the dozen or so worn links, using riveted shackles only.

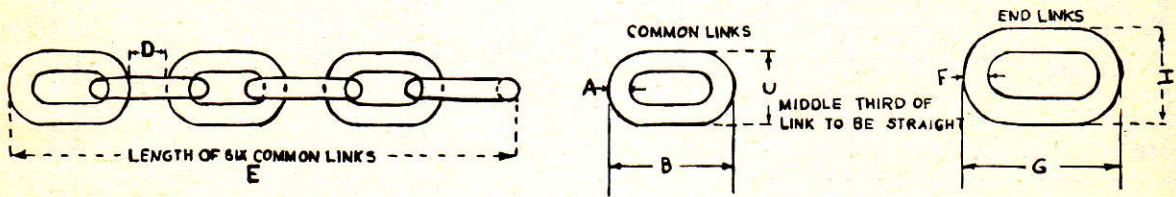

Common links					End links			Wrought iron		Steel		Iron or steel	
A	B	C	D	E	F	G	H	Proof strain in pounds	Breaking strain in pounds	Proof strain in pounds	Breaking strain in pounds	Approximate weight per fathom in pounds	Approximate weight per 15 fathoms
1/2	3	1 7/8	1	13	3/4	4 1/2	2 5/8	6,400	12,800	7,500	15,000	14	210
3/4	4 1/2	2 5/8	1 1/2	19 1/2	7/8	5 3/4	3 3/8	14,000	28,000	16,000	32,000	29 1/2	442
7/8	5 1/4	3 1/8	1 3/4	22 3/4	1 1/8	6 3/4	3 7/8	19,000	38,000	22,000	44,000	40 1/2	608
1	6	3 1/2	2	26	1 1/4	7 1/2	4 3/8	25,000	50,000	29,000	58,000	52	780
1 1/4	6 3/4	3 7/8	2 1/4	29 1/4	1 1/2	8 1/2	4 7/8	33,000	66,000	38,500	77,000	66	990
1 1/4	7 1/2	4 3/8	2 1/2	32 1/2	1 5/8	9	5 1/4	39,000	78,000	45,500	91,000	83	1,245
1 1/2	9	5 1/4	3	39	1 7/8	11 1/4	6 1/2	56,000	112,000	65,500	131,000	117 1/2	1,762
1 5/8	9 3/4	5 11/16	3 1/4	42 1/2	2 1/8	11 3/4	6 5/8	65,500	131,000	76,500	153,000	136	2,040
1 3/4	10 1/2	6 1/16	3 1/2	45 1/2	2 1/4	12	7 1/4	74,000	148,000	86,500	173,000	158	2,370
1 7/8	11 1/4	6 1/2	3 3/4	48 3/4	2 3/8	12 3/4	7 7/8	85,500	171,000	100,000	200,000	176	2,640

FIGURE 24-40.—Buoy chain.

24-9-10 Chain Bridles—

A. Bridles are used on lighted buoys and unlighted sound buoys. They are made of two short lengths

of common links of wrought iron or steel buoy chain connected by a large center ring. They have special end links similar to regular shots of buoy chain. See figure 24-41 for dimensions.

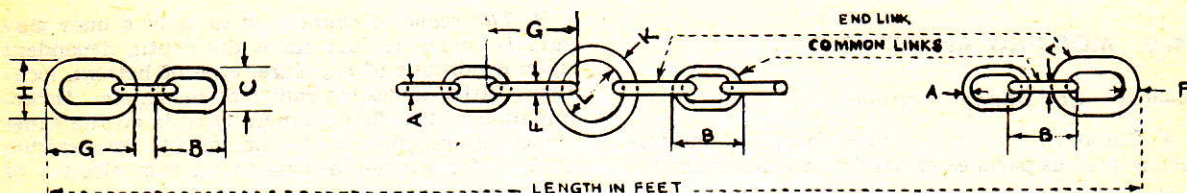

Type of buoy	Common links			End links			Center ring		Number of common links	Length in feet tolerance 5%	Approximate weight in pounds	
	A	B	C	F	G	H	K	L				
10 x 39 W	1 1/2	9	5 1/4	1 3/8	11 3/4	6 1/2	2 1/4	8	44	26	580	
9 x 39 W	1 1/2	9	5 1/4	1 3/8	11 3/4	6 1/2	2 1/4	8	44	26		
9 x 38 W	1 1/2	9	5 1/4	1 3/8	11 3/4	6 1/2	2 1/4	8	44	26		
9 x 32 B & G	1 1/2	9	5 1/4	1 3/8	11 3/4	6 1/2	2 1/4	8	28	18	417	
Bell buoy, ballast ball	1 1/4	7 1/2	4 3/8	1 1/2	9	5 1/4	1 3/4	6	52	23	362	
Type "C"	1 1/4	7 1/2	4 3/8	1 1/2	9	5 1/4	1 3/4	6	48	23	320	
Bell buoy, fixed cwt.	1 1/4	7 1/2	4 3/8	1 1/2	9	5 1/4	1 3/4	6	28	15	227	
8 x 26 (Group)	1 1/4	7 1/2	4 3/8	1 1/2	9	5 1/4	1 3/4	6	28	15		
8 x 23 W	1 1/4	7 1/2	4 3/8	1 1/2	9	5 1/4	1 3/4	6	28	15		
8 x 20	1 1/4	7 1/2	4 3/8	1 1/2	9	5 1/4	1 3/4	6	28	15		
9-B	1 1/4	7 1/2	4 3/8	1 1/2	9	5 1/4	1 3/4	6	28	15		
8-B	1 1/4	7 1/2	4 3/8	1 1/2	9	5 1/4	1 3/4	6	28	15		
7-W	1 1/4	7 1/2	4 3/8	1 1/2	9	5 1/4	1 3/4	6	28	15		
7-FE	1 1/4	7 1/2	4 3/8	1 1/2	9	5 1/4	1 3/4	6	28	15		
7 x 18	1	6	3 1/2	1 1/4	7 1/2	4 3/8	1 3/4	6	36	12		142
Converted B III	1	6	3 1/2	1 1/4	7 1/2	4 3/8	1 3/4	6	28	12		128
6 x 20	1	6	3 1/2	1 1/4	7 1/2	4 3/8	1 3/4	6	28	12	75	
5 x 15	1	6	3 1/2	1 1/4	7 1/2	4 3/8	1 3/4	6	28	12		
5FE	1	6	3 1/2	1 1/4	7 1/2	4 3/8	1 3/4	6	28	12		
3 1/2 x 10	1	6	3 1/2	1 1/4	7 1/2	4 3/8	1 3/4	6	28	12		
3 1/2 FE	1	6	3 1/2	1 1/4	7 1/2	4 3/8	1 3/4	6	28	12		

FIGURE 24-41.—Chain bridles.

24-9-15 Shackles—

A. Buoy shackles (fig. 24-42) are classified in two types, one having split keys to secure the shackle pin, and the other having a riveted pin.

B. *Riveted-pin shackles* are cupped for riveting and are fitted with a stop pin which is driven through the knuckle, heated, and headed over. Riveted-pin shackles are always used in repairing sections of chain worn by chafing. Riveted-pin shackles are available in the sizes described below for the split-key shackles.

C. *Split-key shackles* are used in making connections between the buoy and the bridle, the chain, and the sinker. They are easily unshackled *provided the split key is bent properly*. Using a key or blacksmith straight peen hammer, the split leaves of the key should be spread open. They should not be bent double back around the shackle pin but should be flared to about a 50° angle on each side, with each leaf of the key also twisting slightly back toward the eye of the shackle. This is accom-

plished by striking the spread keys slightly off center with the broad face of the hammer as soon as the key is spread 30° or so. Split keys spread in this manner should come together easily when struck between two key hammers or top mauls. Split keys are bent cold. They are available in four sizes formerly identified by class, i. e., first, second, etc., and now classified by wire diameter.

(1) The first-class shackle is 2-inch diameter. The second-class shackle is 1 3/4-inch diameter. The third-class shackle is 1 1/2-inch diameter. The fourth-class shackle is 1-inch diameter. A large 2 1/2-inch diameter shackle is also available as a split-key shackle only.

(2) The shackle pins are made from round stock, headed on one end and of sufficient length to be fitted with a split-key driven in a slot in the outer end to prevent the pin from pulling out.

(3) A special 2 1/2-inch mooring shackle is provided for attaching the bridle to the larger lighted buoys.

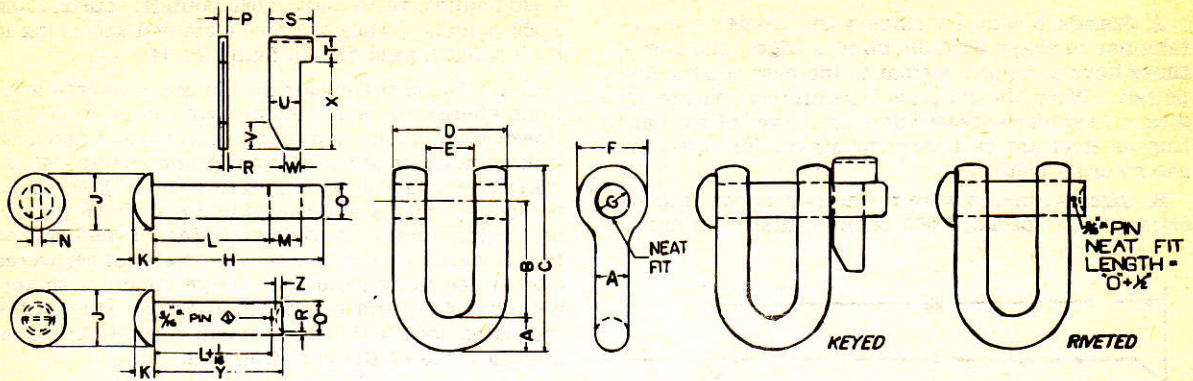

Type		Shackle dimensions in inches																				Strain-Pounds					
A	B	C	D	E	F	G	H	I	J	K	L	M	N	O	P	Q	R	S	T	U	V	W	X	Y	Z	Breaking	Proof
2	7 3/4	11 7/8	7	3	4 1/4	2 1/16	9 1/2	---	3	1 1/8	7 1/16	1 7/16	7/16	2	3/8	3/16	3/16	2	1 3/8	1 3/8	1 1/4	3/4	4	8	3/8	226,200	113,100
1 3/4	6 7/8	10 1/2	6 1/4	2 3/4	3 3/4	1 13/16	8 3/4	---	2 3/4	1	6 5/16	1 7/16	7/16	1 3/4	3/8	3/16	3/16	2	1 1/8	1 3/8	1 1/4	3/4	4	7 1/8	3/8	172,800	86,400
1 1/2	5 1/4	8 3/8	5 1/4	2 1/4	3 1/4	1 9/16	7 3/4	---	2 1/2	7/8	5 5/16	1 7/16	7/16	1 1/2	3/8	3/16	3/16	2	1 1/8	1 3/8	1 1/4	3/4	4	5 7/8	3/4	126,700	63,350
1	4 1/8	6 1/8	4 1/4	2	2 1/32	6	7 3/4	---	1 5/8	5/8	4 5/16	1 1/16	5/16	1	1/4	1/8	1/8	1 3/8	3/4	1	1 1/4	1 1/2	2 1/2	4 7/8	3/4	57,000	28,500
2 1/2	9	14 1/4	11	6	5 1/2	2 9/16	13 5/8	---	3 1/2	1 3/8	11 1/8	1 7/16	9/16	2 1/2	1/2	---	1/4	2	1 3/8	1 3/8	1 1/4	3/4	4 1/2	---	---	352,800	176,400

FIGURE 24-42.—Buoy shackles, split-key and rivet-pin types.

24-9-20 Swivels—

A. Swivels (fig. 24-43) are made of steel or wrought iron and identified by the thickness of the eye material, as 2-, 1 3/4-, 1 1/2-, or 1 1/4-inch swivels. Like shackles, they were formerly identified by class sizes. Though usually located between the bridle

and the mooring chain, they are sometimes placed about one shot below the bridle.

B. When difficulty is experienced with the buoy's rotation, two or three swivels may be used, equally spaced between various lengths of the mooring chain. The size swivel to use with a mooring should compare in strength with the rest of the mooring.

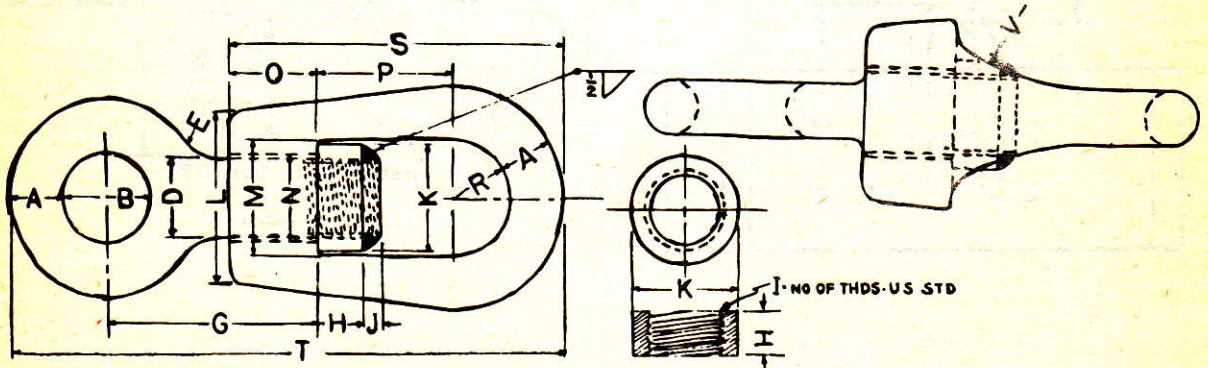

Type		Swivel dimensions in inches																			Strain-Pounds		
A	B	C	D	E	F	G	H	I	J	K	L	M	N	O	P	Q	R	S	T	U	V	Breaking	Proof
2	3	---	3	1 5/8	---	7 1/4	1 1/2	3 1/2	1/2	4	6	4 3/8	3 1/4	3	4 3/4	---	2 1/4	12	19 3/4	---	9	163,000	81,500
1 3/4	2 3/4	---	2 1/2	1 3/8	---	6 5/8	1 1/2	4	1/2	3 1/4	5	3 3/8	2 3/4	2 3/4	4 3/8	---	1 7/8	10 3/4	17 3/4	---	8	118,000	59,000
1 1/2	2 1/2	---	2 1/4	1 1/4	---	6	1 1/4	4 1/2	3/8	3	4 1/2	3 1/4	2 1/2	2 1/2	3 7/8	---	1 3/8	9 1/2	15 3/4	---	7	90,000	45,000
1 1/4	2 1/4	---	2	1 1/8	---	4 7/8	1 1/4	4 1/2	1/2	2 3/4	4	3	2 1/4	2	3	---	1 1/2	7 3/4	13	---	6 1/2	60,000	30,000

FIGURE 24-43.—Buoy swivels.

24-9-25 Sinkers—

A. Standard concrete sinkers (fig. 24-44) are rectangular in shape with chamfered edges, and sometimes have a cupped bottom to increase the holding power. Often the concrete is reinforced with metal scraps to achieve greater density. Eyes of wrought iron or steel are cast into the sinker for fastening the mooring chain.

B. Sizes.—Sinkers were formerly grouped into six classes, i. e.; special, 8,500 pounds; first class extra,

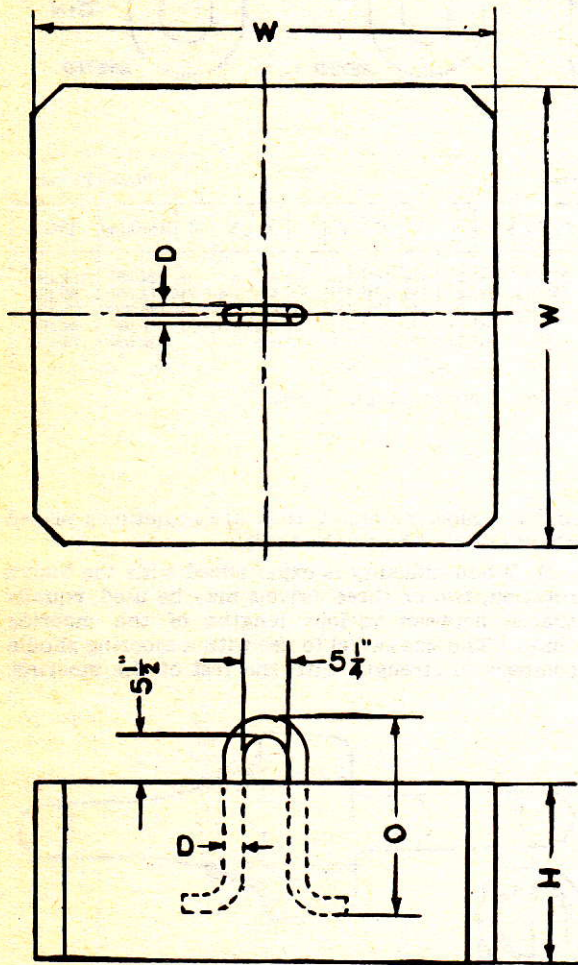

Weight	W	H	D	O
12,700	60	42	2	22 1/2
8,500	60	28	2	22 1/2
6,500	58	23	2	22 1/2
5,000	54	21	2	22 1/2
4,000	50	19	2	22 1/2
3,000	45	18	2	22 1/2
2,000	40	15	1 1/2	13
1,000	32	12	1 1/2	13
500	24	10	1 1/2	13
300	20	8	1 1/2	13

All dimensions in inches, weights in pounds.

FIGURE 24-44.—Standard concrete sinkers.

6,500 pounds; first class, 5,000 pounds; second class, 4,000 pounds; third class, 3,000 pounds; fourth class, 2,000 pounds. They are now classified according to their weight, as shown in figure 24-44.

C. Cast-iron sinkers are still in use in certain locations where a concentrated mass of weight is desired. However, authorization for the purchase of cast-iron sinkers must be secured from Headquarters. Cast-iron sinkers have a net weight in water of 336 pounds per cubic foot as against concrete with 96 pounds per cubic foot. To reduce losses of sinkers on Pacific bars where moorings are often not recovered due to becoming sanded in, large concrete sinkers weighing 4, 5, and 6 tons, built in the shape of a truncated cone with a suction cup bottom have been used in place of the cast-iron sinkers.

24-9-30 Ballast Balls—

A. Ballast balls are made of cast iron with forged steel eyes and are classified according to the weights shown in the table, figure 24-45. They are shackled to the mooring eyes of all classes of standard nuns and cans, bell buoys which do not have a fixed counterweight, and first class spars, when the weight of the mooring chain is insufficient to maintain the required freeboard or float the buoy in an upright position.

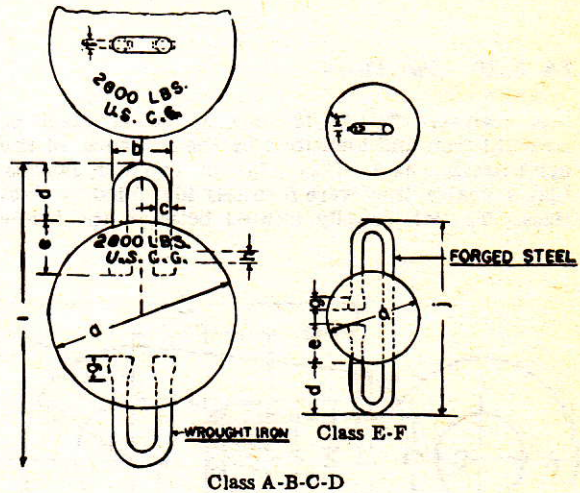

Class	Dimensions in inches										Weight in pounds
	a	b	c	d	e	f	g	h	i	j	
A...	26 1/4	8	2	8 1/2	7	1	3	2	43 1/4	-----	2,600
B...	24	8	2	8 1/2	7	1	3	2	41	-----	2,000
C...	20 1/2	8	2	8 1/2	7	1	3	2	37 1/2	-----	1,260
D...	14	5 1/2	1 3/8	7	5	1 1/2	2 1/2	1 3/8	28	-----	410
E...	11	5 1/2	1 3/8	7	4	1 1/2	2	1 3/8	-----	25	205
F...	9 1/4	5	1 1/4	7	3 1/2	5/8	1 1/4	1 1/4	-----	23 1/4	120

FIGURE 24-45.—Cast iron ballast balls.

B. *Size to use.*—Under normal conditions the following ballast balls are used.

(1) 2,600 pounds for bell buoys without fixed counterweights.

(2) 1,260 pounds for first-class standard nuns and cans.

(3) 410 pounds for second-class standard nuns and cans.

(4) 120 pounds for third-class standard nuns and cans.

C. *Exceptions.*—Consideration should be given to the depth of water and weight of chain to be used which may modify the above recommendations and permit using a smaller ballast ball.

24-9-35 Selecting Proper Appendages—

A. It is impossible to set up a standard practice of application of the various types or sizes of buoy appendages to suit all conditions. The size and scope of chain, size and type of sinker, etc., vary with conditions, and it rests largely on the commanding officer to make the determination, having regard for the individual circumstances of depth, exposure, condition of the bottom, and any restriction on scope that might be imposed in a narrow channel, etc. The sizes and weights of moorings shown in tables contained in this chapter are only approximate recommendations for average conditions. See Chapter 27, section 27-5-10 for a discussion on this subject.

24-10 REFLEX SIGNALS

24-10-1 General—

A. Several types of reflectors have been developed with varying degrees of success for use on unlighted buoys and minor structures, to render them more useful to night navigation.

B. *Glass button types.*—Commonly used reflectors consist of a flat rectangle, triangle, or square of glass or moulded plastic buttons in a metal frame, which may be bolted to the side of the buoy or structure, or a round metal band inset with glass or plastic buttons which is mounted on legs on top of the buoy. (Glass button reflectors are easily damaged however, by ice and collision.) These types of reflectors are available in red, green or white. Plastic (Stimsonite or equal) reflector buttons may be used as replacement for glass buttons.

C. *Sheet material type.*—Another type of reflecting material consists of a sheet of composition or plastic material inset with minute glass balls, so small as not to be perceptible to the naked eye. While not as efficient as glass or plastic button reflectors, this material is less susceptible to damage and is fairly easily cemented onto the buoy or structure. It is available in sheets or rolls of various widths in red, white, green, and black. (The black reflects white light.)

24-11 MINOR STRUCTURES

24-11-1 General—

A. Minor structures consist of single or multiple wood or iron pilings, wood or steel skeleton towers on concrete, rock, or wooden crib foundations or steel caissons, or concrete or rock towers. Minor structures which are unlighted are called daybeacons. When equipped with lighting apparatus of low candlepower, they are called minor lights.

B. Minor lights are rarely attended, and the structures lack such features as living space for the attendants, enclosed stair wells, etc. There is a certain similarity among such structures, although their heights may vary widely.

C. There are a great many particular types of minor structures in use which have been developed in the past by individual districts to meet specific problems of terrain and climate, and it cannot be said that standardization of minor structures has been achieved as yet. It is the intent of this chapter to present for informative purposes a few representative types of minor structures commonly in use in several districts.

24-11-5 Daybeacons—

A. The term "daybeacon" is used to designate an unlighted minor structure, whereas the term "daymark" designates the daytime characteristic of any aid to navigation such as its shape, color, or other marking.

B. *Purpose.*—Most daybeacons are intended to mark side limits of channels or isolated reefs which are of insufficient importance to navigation to be marked with a light. A high percentage of daybeacons are constructed on submarine sites. Where so built, their foundations are of the same types as those used for minor light structures of the same general size.

C. *Description.*—Daybeacons, being devoid of signaling equipment, depend upon height, coloring, and size to make them conspicuous. Some daybeacons marking isolated dangers or serving as daytime ranges are elaborate skeleton iron structures fitted with wooden slatted targets; others, particularly along the New England and Pacific Coasts, are heavy iron spindles inserted in holes drilled in the ledge rock. Hundreds of the daybeacons marking the Intracoastal Waterway, where the bottom is usually sand or mud, are simple single-pile structures with some kind of conspicuous lateral mark at the top.

D. *Standardization.*—Where daybeacons are used to mark isolated dangers, the tendency has been to add to their distinctiveness by rather wide variation in design, especially where a number of such structures are to be found within a somewhat limited area. In the Intracoastal Waterway and other places where large numbers of daybeacons are used to delineate channel margins, the tendency has been toward a greater uniformity of design, and the coordination of design and lateral significance.

E. *Cost.*—Unlighted daybeacons are usually relatively inexpensive structures, as they are utilized chiefly at points where the volume and importance of the traffic does not warrant the maintenance of costly aids. They are sometimes fitted with reflectors which enable them to serve to a limited degree at night.

F. *Intracoastal Waterway daybeacon.*—Figure 24-46 illustrates a typical single-pile daybeacon with reflector, as used on the Intracoastal Waterway. These single-pile structures are easily damaged by collision and are being replaced by buoys wherever possible.

following paragraphs. They are representative of similar structures in use throughout the Service.

B. *Single-pile structures.*—Figures 24-47 and 24-48 illustrate two types of wooden single-pile minor light structures. They are easily susceptible to damage by collision and their use is being discontinued in such areas as the Intracoastal Waterway where aids are often struck by tows.

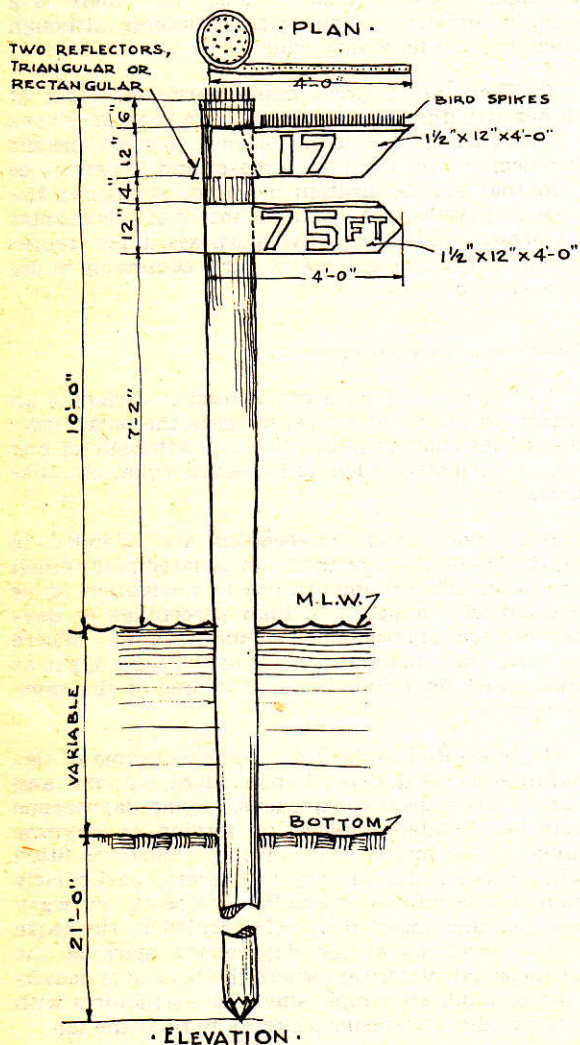

FIGURE 24-46.—Single-pile daybeacon (Eighth District).

24-11-10 Single and Multiple Wooden Piling Lighted Structures—

A. Sketches, photographs, and brief descriptions of single- and multiple-pile lighted structures developed for use in several districts are given in the

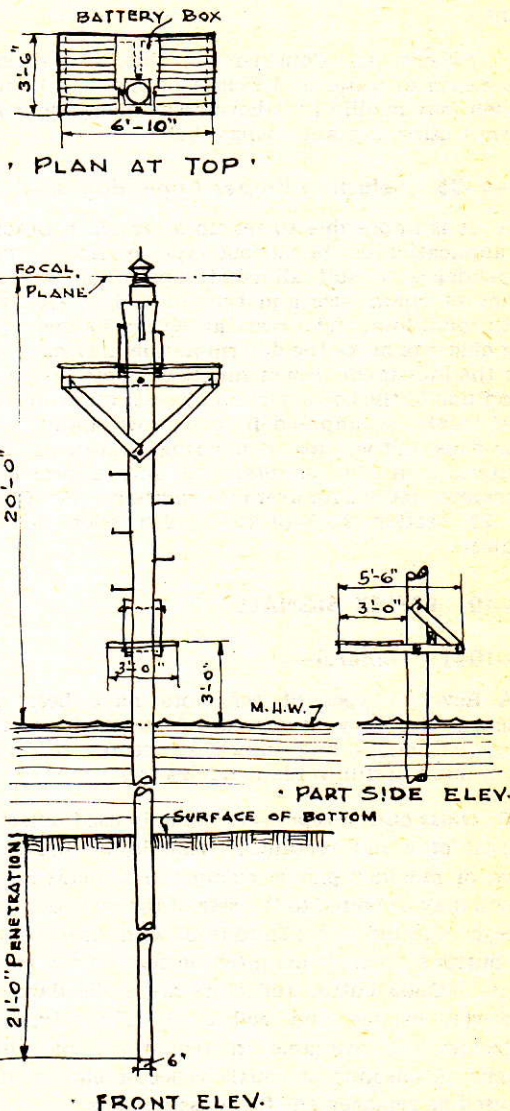

FIGURE 24-47.—Minor light, single wood pile structure (Eighth District).

C. *Three-pile structure.*—Figure 24-49 illustrates a three-pile triangular pyramidal structure formerly used on the Intracoastal Waterway, and for marking harbor channels. Figure 24-50 illustrates a similar structure. Figure 24-51 illustrates a three-pile structure used in the Fifth District. The three-pile structure should not be used under ice or severe exposure conditions.

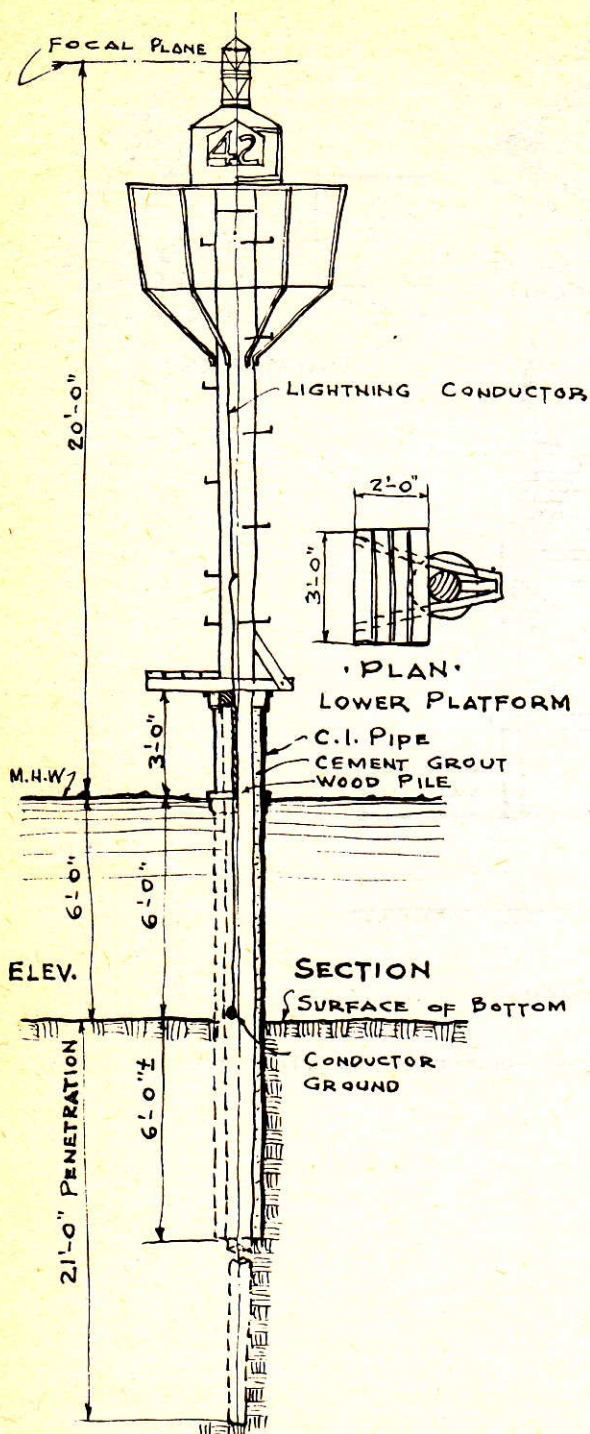

FIGURE 24-48.—Minor light, single wood pile (Eighth District).

D. *Three-pile dolphin*.—Due to increased costs of material and construction, a more simplified three-pile dolphin (fig. 24-52) was developed in the Eighth District. Where it is impractical to drive these piles on a batter, three piles may be driven vertically, spaced to form a triangle, and then pulled together at the top by a winch line, after which they are secured with several turns of galvanized wire secured with staples and clamps.

(1) After the pile tops have been squared up, stringer pieces are spiked to the piles at the cut-off and upon these stringers the battery house is placed and secured. Except for a lower girt, no bracing is used on the piles to avoid catching drift, but across two piles beneath the battery box, $1\frac{1}{2}$ -inch by 4-inch pieces are spiked horizontally about 21 inches apart to serve as a ladder. A steel strap at battery box floor level or extension of the battery box foundation stringers with a cross piece at their outer end, forms a guard or back rest.

(2) To service the batteries, the light attendant stands on one of the climbing rungs, having the guard and back rest for support. To service the lantern, the attendant stands upon the extended battery box stringers. A truncated top on the battery box gives a neater appearance than the flat top, and sheds water.

E. *Three-pile dolphin*.—Figure 24-53 illustrates a three-pile dolphin used in the Fifth District on the Intracoastal Waterway.

F. A *five-pile dolphin* has been designed for use at more exposed locations. In this structure, figure 24-54, 4 piles are driven around a center pile. The cut-off on the center pile is 12 inches higher than the four surrounding piles to serve as a support for foundation stringers which in turn support the battery box. The additional piles and improved battery box support construction will provide a stiffer dolphin structure than the 3-pile structure described above, for more exposed locations.

G. *Range structures*.—Figures 24-55, 24-56 and 24-57 show several types of range structures. The square structure with a four-post pyramid as shown in figure 24-56 is very satisfactory for tall structures. Only the range face need be slatted, with the other three sides cross-braced for stiffness. Figures 24-58, 24-59 and 24-60 show a four-pile structure with a two-slatted triangular pyramid which has been found satisfactory for moderate heights. Figure 24-61 shows a four-pile range structure also mounting a lateral or passing light.

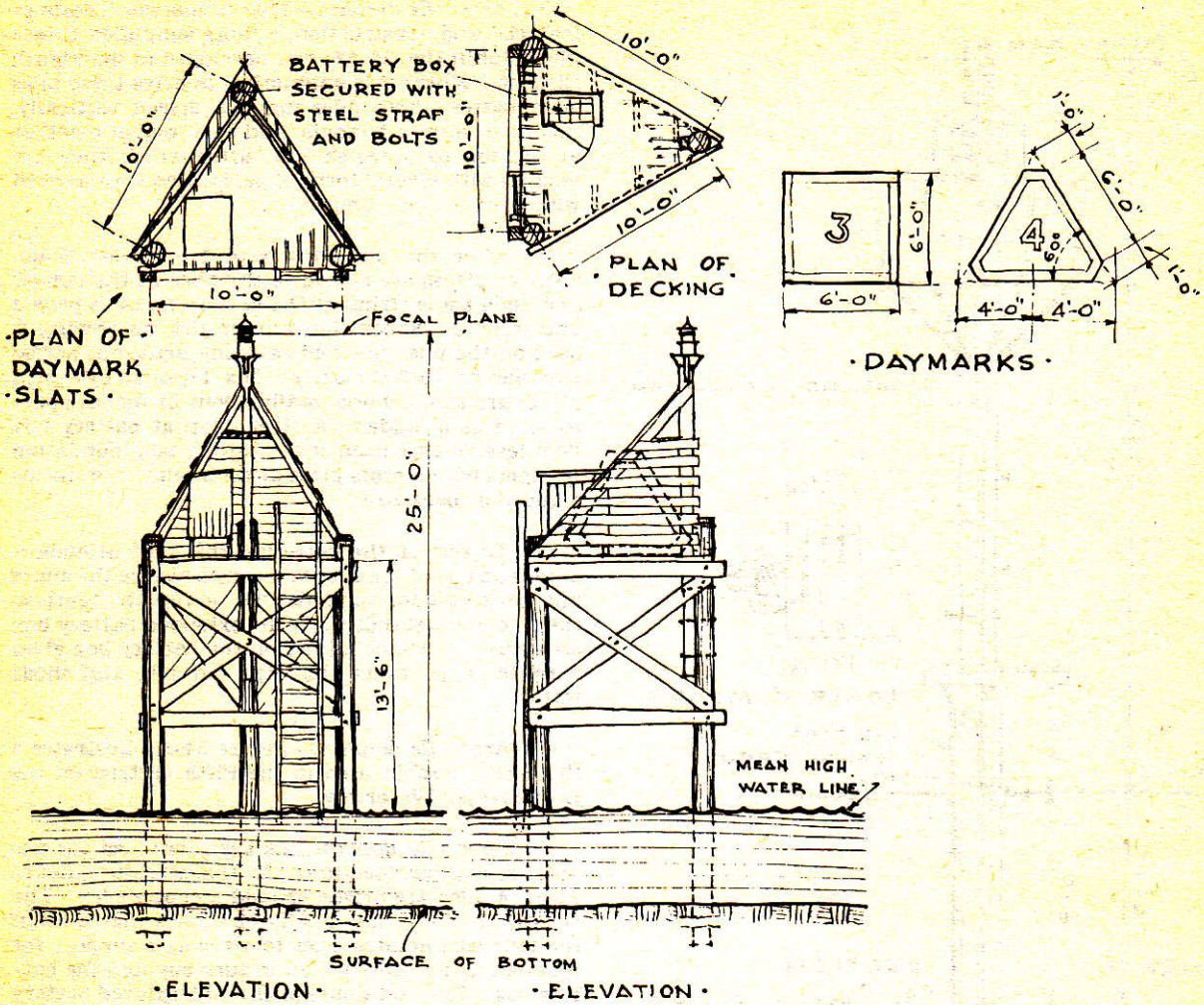

FIGURE 24-49.—Minor light, three-pile-and-brace type (Eighth District).

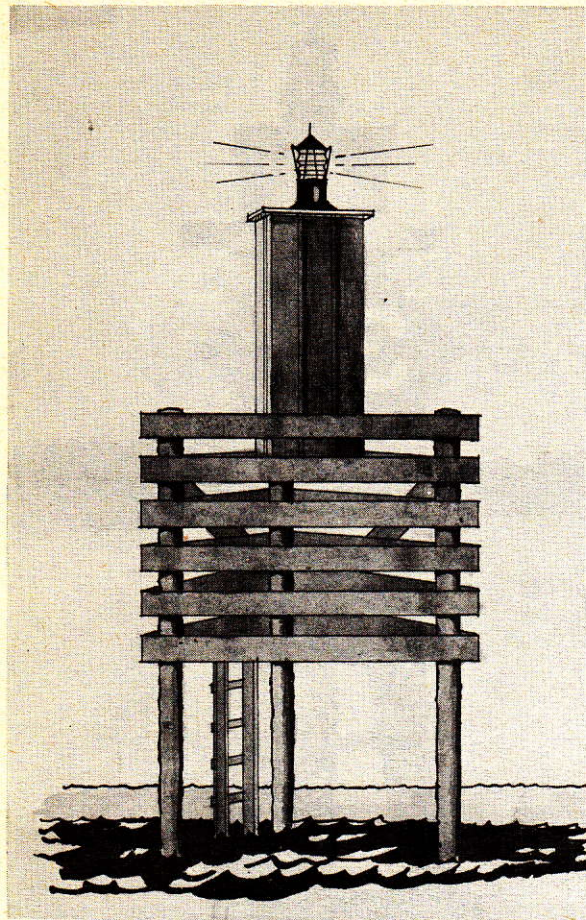

FIGURE 24-50.—Three-pile minor light (Intracoastal Waterway).

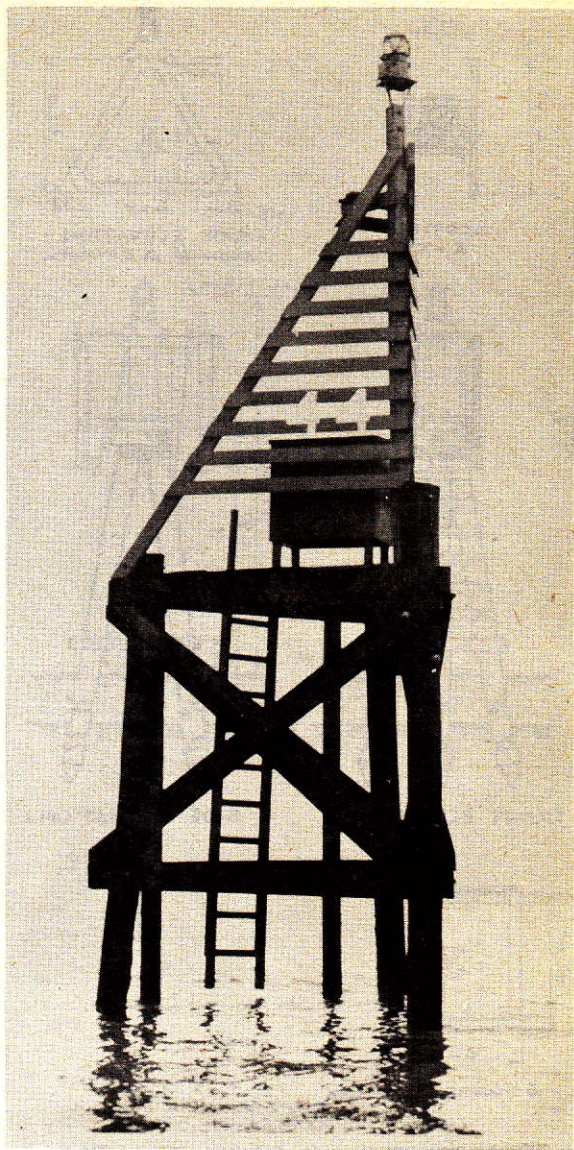

FIGURE 24-51.—Three-pile minor light (Fifth District).

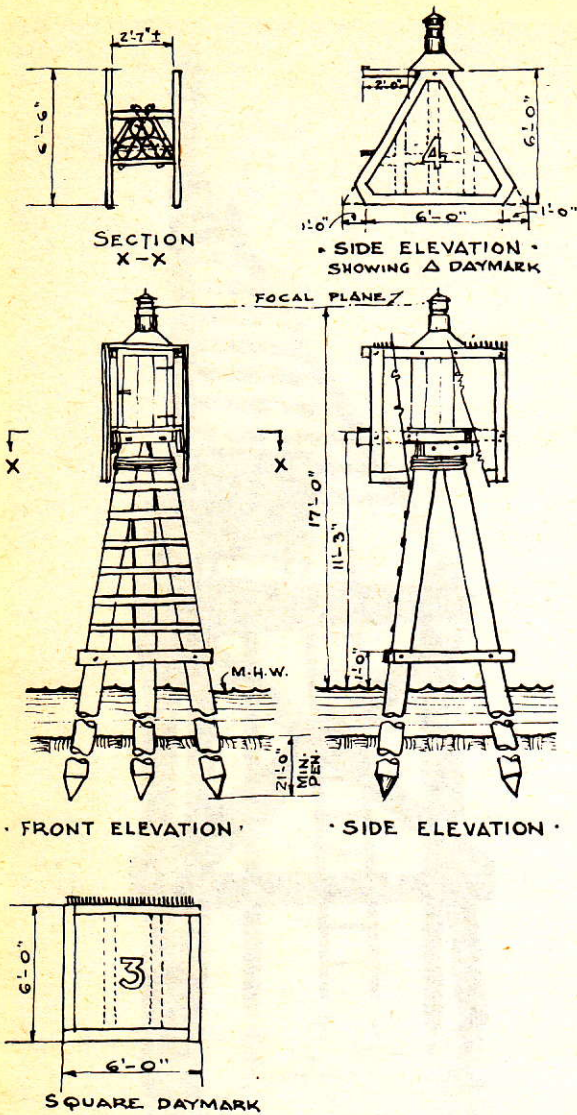

FIGURE 24-52.—Three-pile dolphin (Eighth District).



FIGURE 24-53.—Three-pile dolphin (Fifth District).

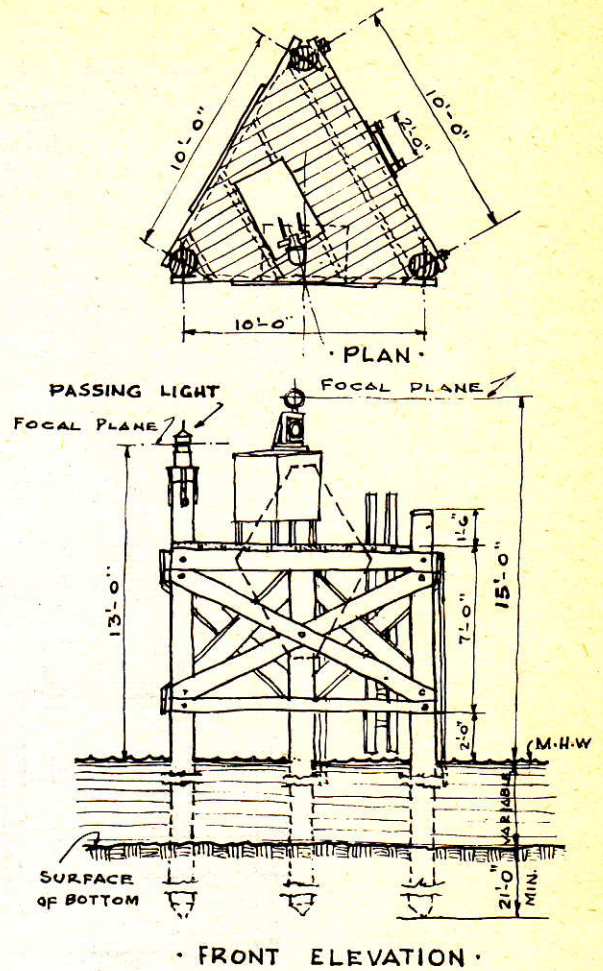
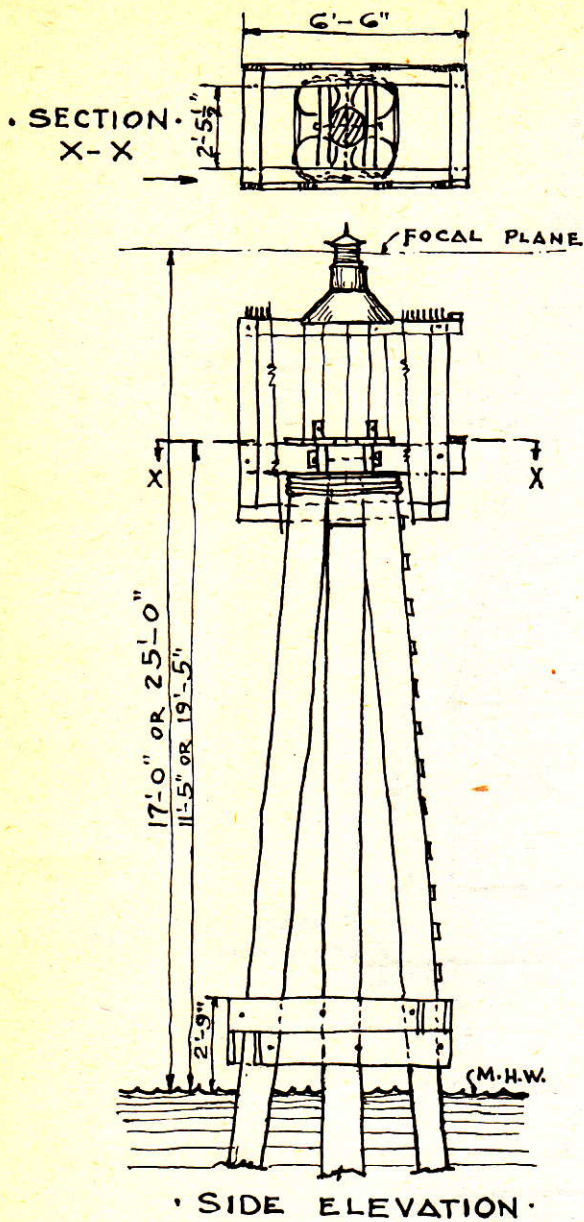

FIGURE 24-55.—Three-pile minor range light (Eighth District).

FIGURE 24-54.—Five-pile dolphin (Eighth District).

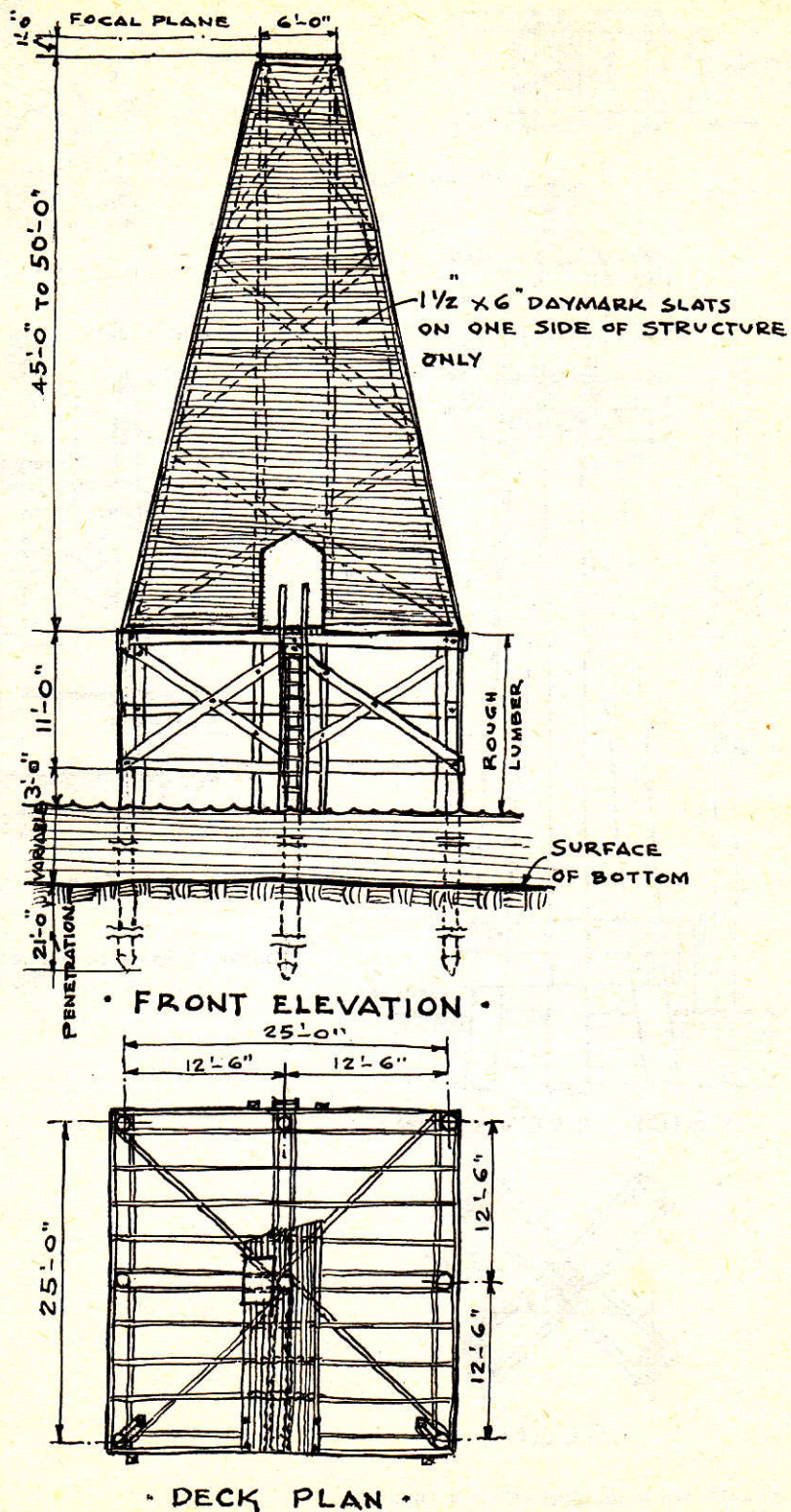

FIGURE 24-56.—Nine-pile minor range light (Eighth District).

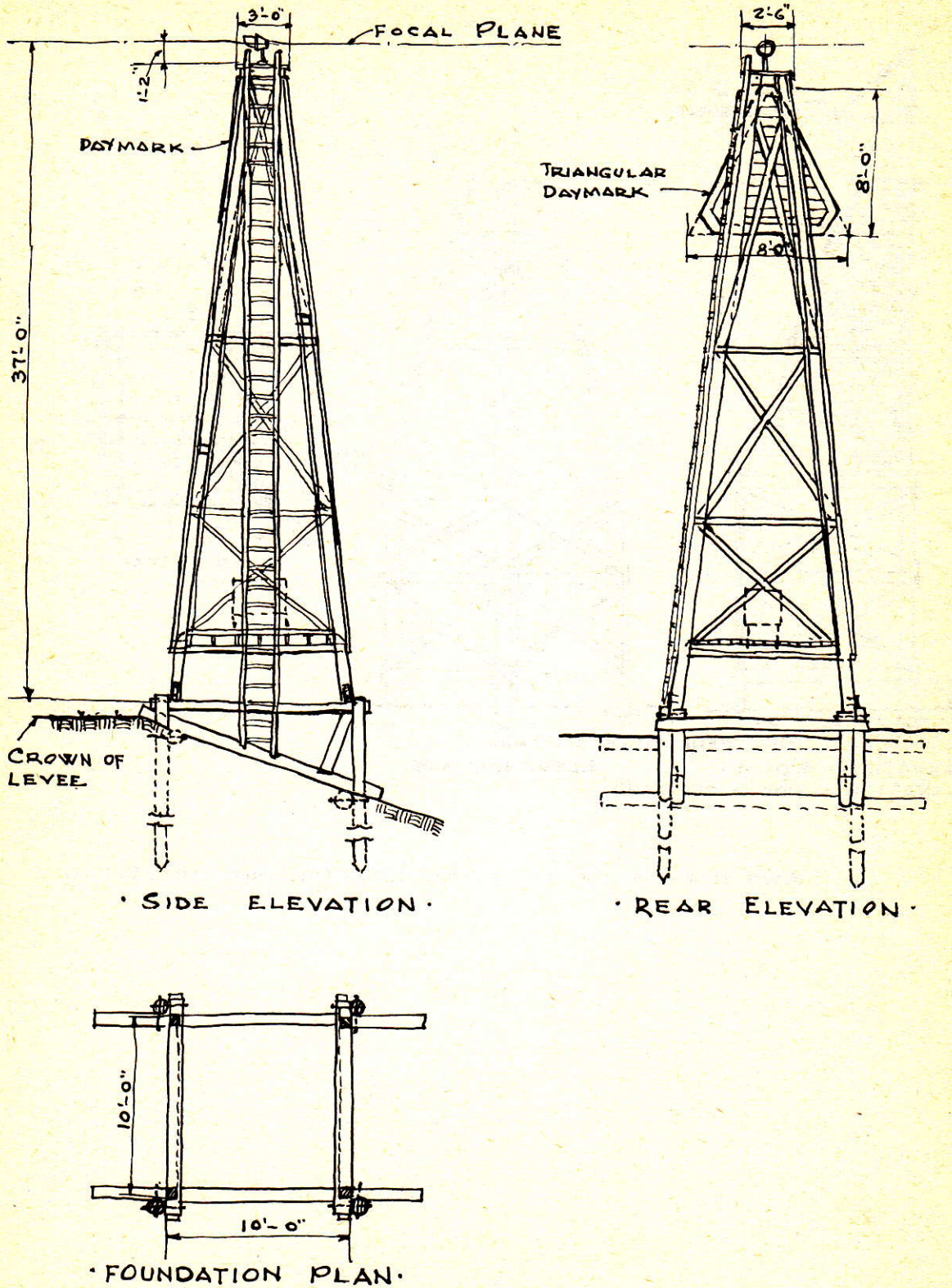

FIGURE 24-57.—Rear range light (Eighth District).

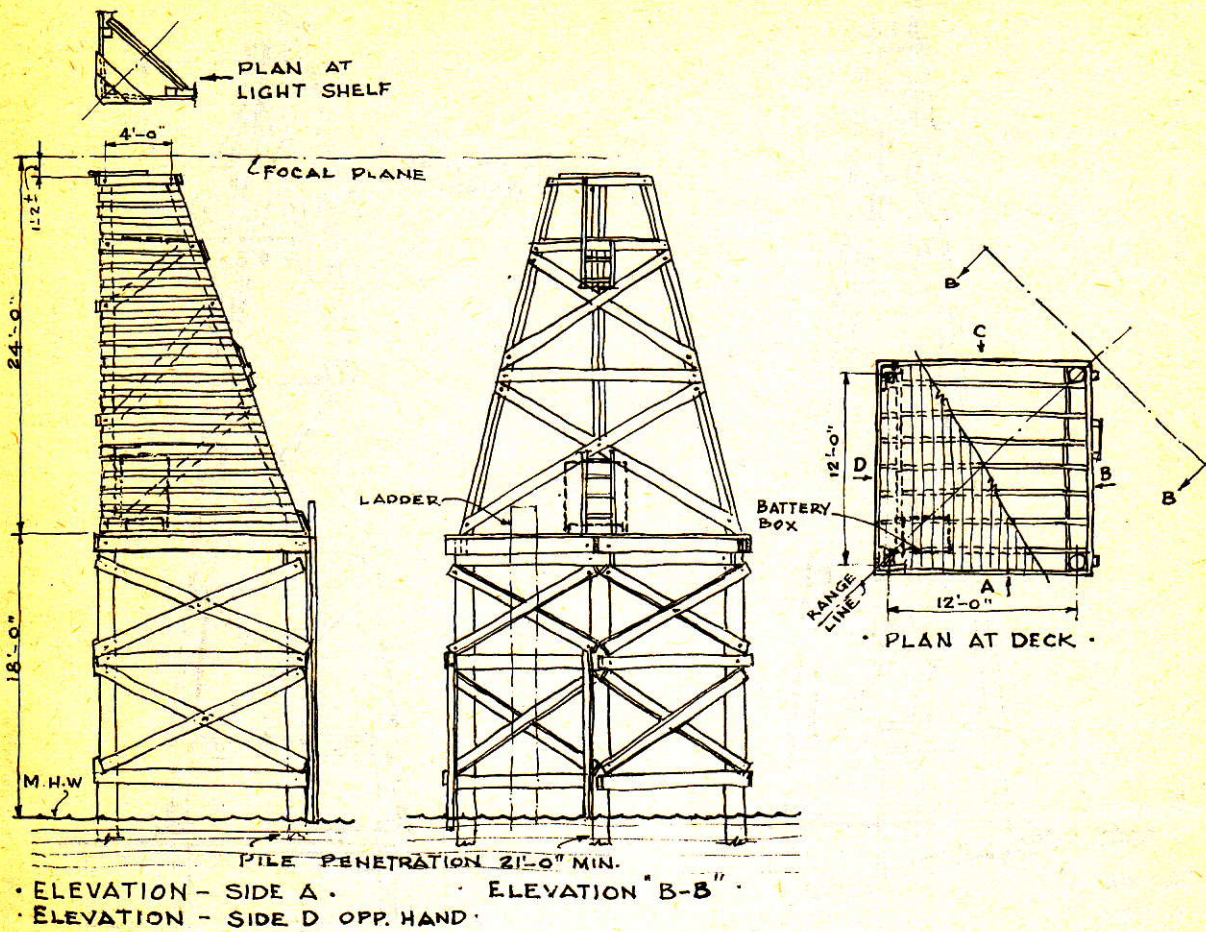

FIGURE 24-58.—Four-pile range structure, 42-foot focal plane (Eighth District).

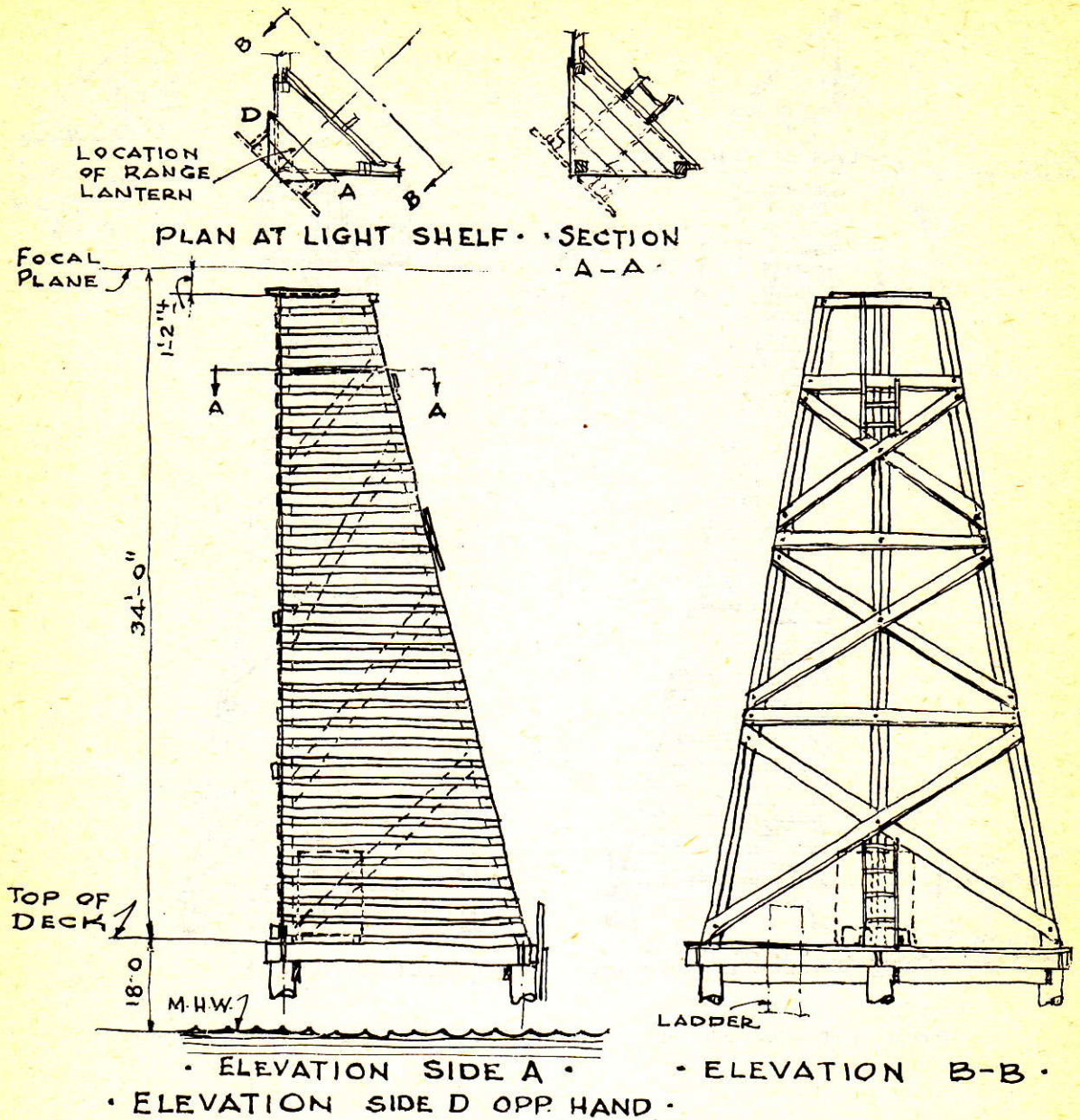

FIGURE 24-59.—Four-pile range structure, 52-foot focal plane (Eighth District).

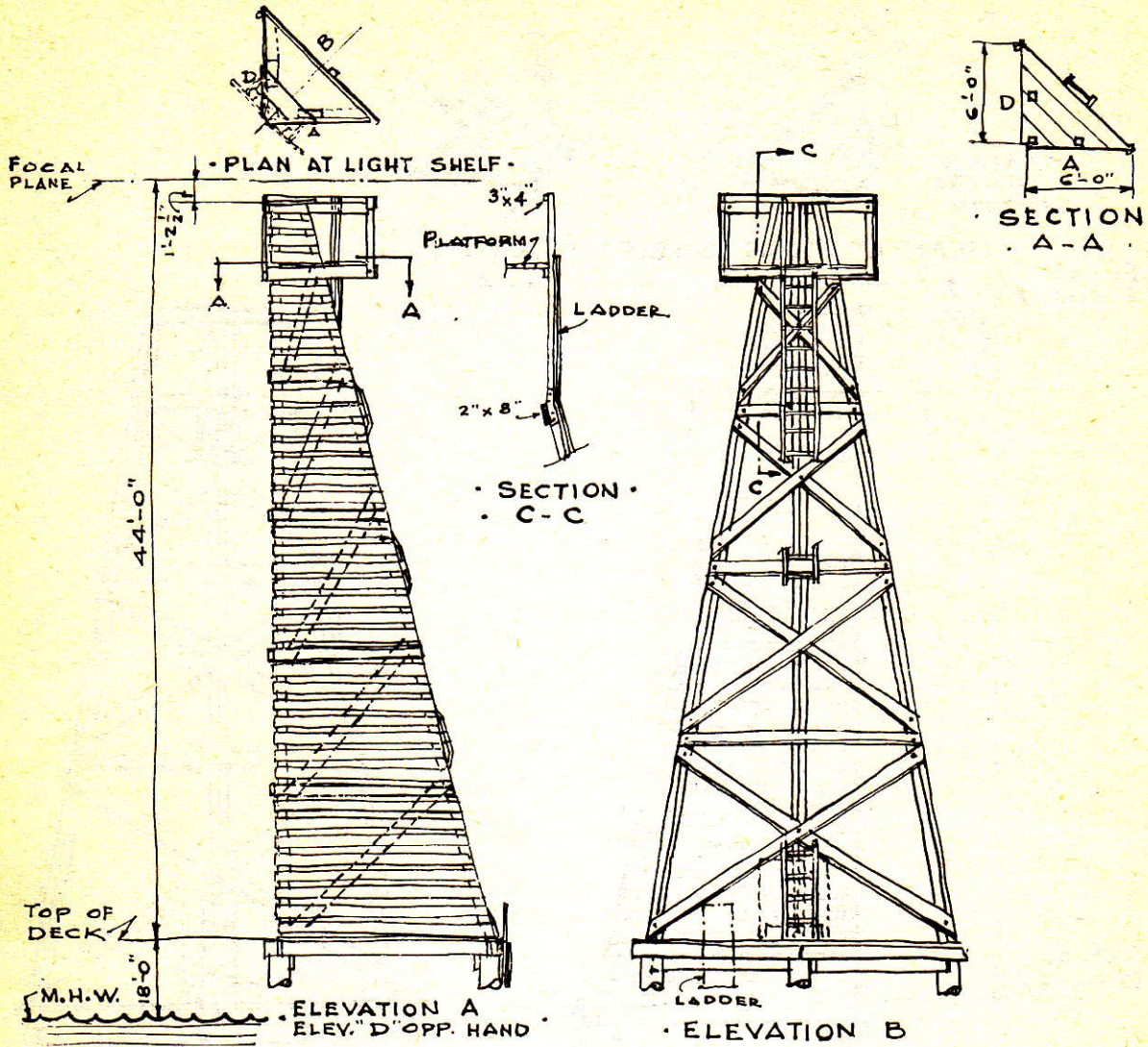

FIGURE 24-60.—Four-pile range structure, 62-foot focal plane (Eighth District).

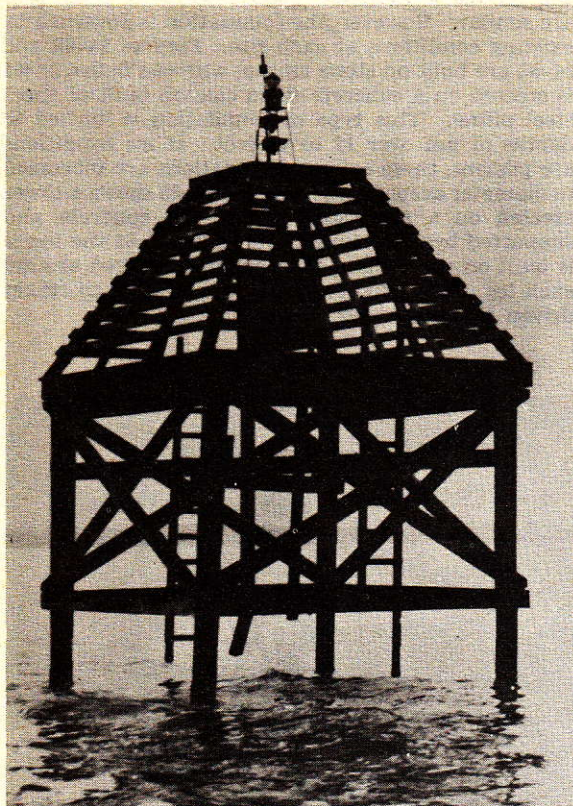

FIGURE 24-61.—Four-pile range structure with auxiliary passing light.

H. *Penetration of piles.*—By experience it has been found that a penetration of 21 feet is generally suitable in driving piles. The reason for this amount of penetration is to prevent uplift of the pilings, due to their inherent buoyancy, or from collision. If support of weight was the only consideration, a penetration of 5 to 10 feet would be adequate. The actual amount of penetration required may, of course, vary, depending upon the nature of the bottom. In very hard formation where the pile tends to split or broom with excessive hammering, the driving is stopped when apparent refusal is reached. Where the bottom is exceedingly soft, longer piles are used, or two piles may be spliced together to give increased penetration. In sand bottom, the penetration is secured by jetting with little use of the hammer other than setting it on the pile for weight. In clay and mud bottoms the hammer is used to drive, and sometimes both jet and hammer are used.

I. *Lumber.*—Long leaf southern yellow pine or Douglas fir has been found to be excellent lumber for structures. Present practice in the Eighth District is to specify common southern yellow pine. For substructure, braces, joists, etc., 12-pound creosote treatment is specified. Daymarkers, battery boxes, ladders, and superstructures on large structures are made of untreated material. Piles are

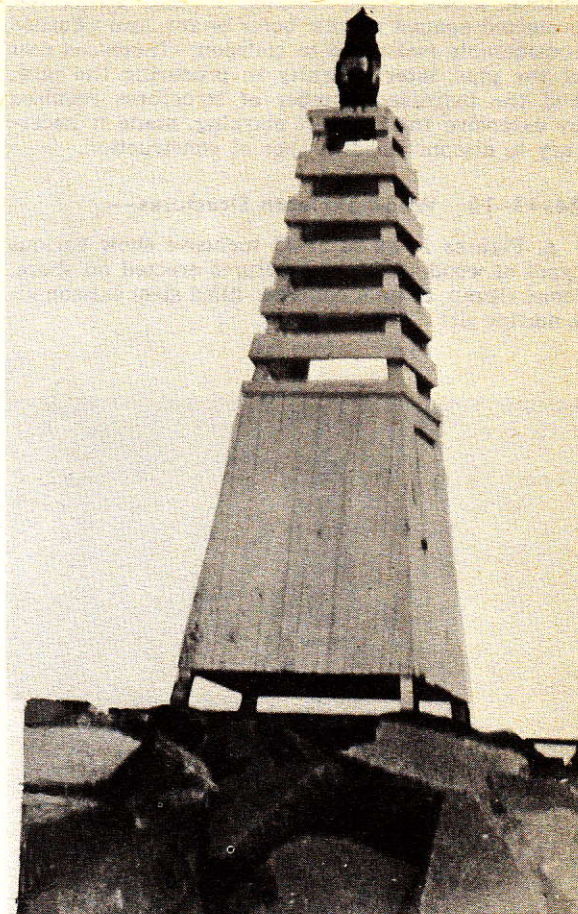

FIGURE 24-62.—Wooden minor light structure on stone riprap.

given 22-pound Full Cell Creosote treatment, which is practically refusal. Teredo and Lymnora attack is so persistent in the Gulf waters that use of less than this treatment is not wise, and untreated piles are quickly attacked. However, cause of destruction on the Intracoastal Waterway is frequently not the marine borers, but collision by tows, and sometimes structures are so short-lived that even untreated piling would have sufficed. Fortunately, a large enough percentage of structures survive collision damage to justify the precautionary creosote treatment.

J. *Wood piles encased in iron pipe.*—An interesting feature of construction used in the Eighth District in earlier structures, but now discontinued, was the use of 16-inch cast iron pipe piling. For piling, square hewn or sawn timbers were used with corners cut to form an octagonal cross section. After driving these piles, the pipe sections were slipped over the piling, bell up, to a penetration of 6 feet below bottom, terminating 3 feet above water, and

the space between pipe and piles was filled with cement grout. This resulted in stiff structures, protected against marine borer or rot, and afforded considerable resistance to collision. Increased cost of the pipe, later difficulty in procuring the pipe, and the increased number of structures required by extensive Intracoastal marking, made it necessary to discontinue this type of construction.

24-11-15 Wood Skeleton Structures—

A. Figures 24-62 to 24-67 inclusive show various types of wood skeleton structures erected on shore, stone riprap, or on a concrete-filled steel caisson on a marine site.

B. *Different foundations.*—It will be noted that the daymark skeleton wood towers in each case are similar. However, the foundation is governed by existing conditions at each site. Figures 24-62 and 24-63 are built on stone riprap, whereas figure 24-64 is erected on a concrete-filled caisson built of sheet steel piling. This type of foundation is limited to depths of not over 12 to 15 feet. If ice conditions are present, these caisson foundations are increased in diameter accordingly. Figure 24-65 shows a tower erected on a steel shell filled with concrete and supported by rock riprap. In figure 24-66 the tower is built on the ground with concrete poured around each leg, and in figure 24-67, it is secured to stakes driven in the ground.

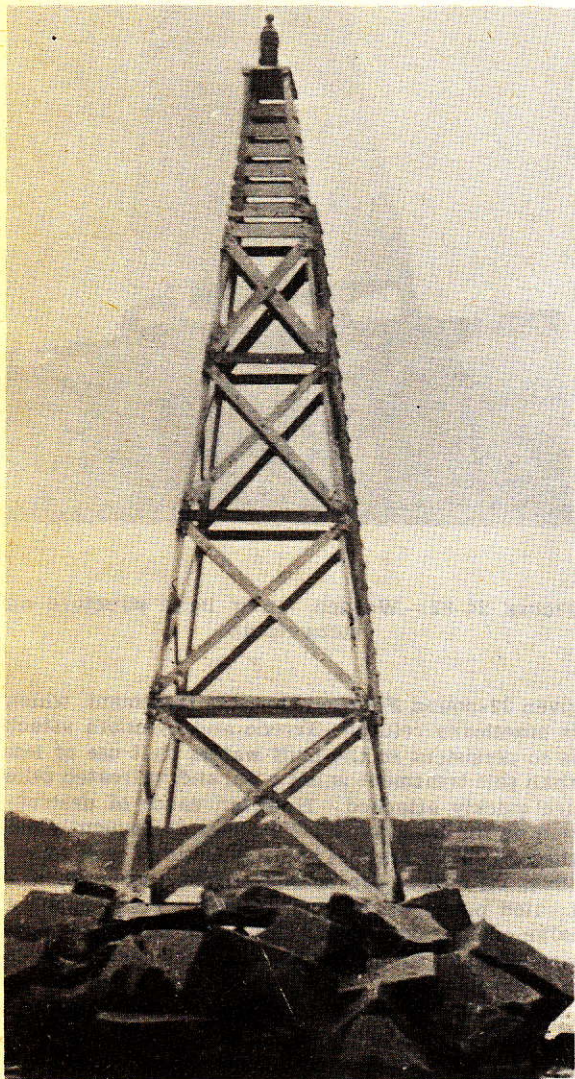

FIGURE 24-63.—Wood skeleton minor light structure on stone riprap.

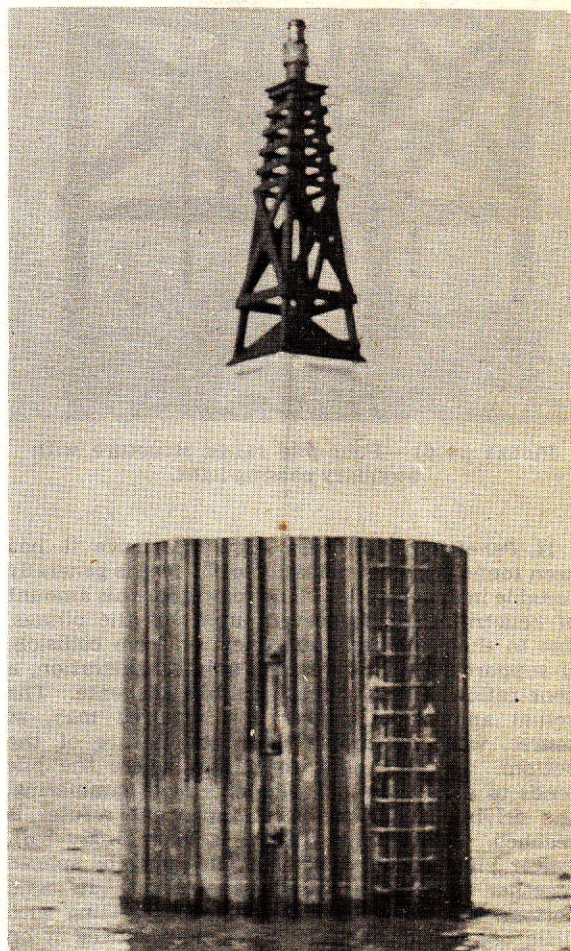

FIGURE 24-64.—Wood skeleton minor light structure on concrete-filled steel caisson.



FIGURE 24-65.—Wood skeleton minor light structure on concrete-filled steel shell.

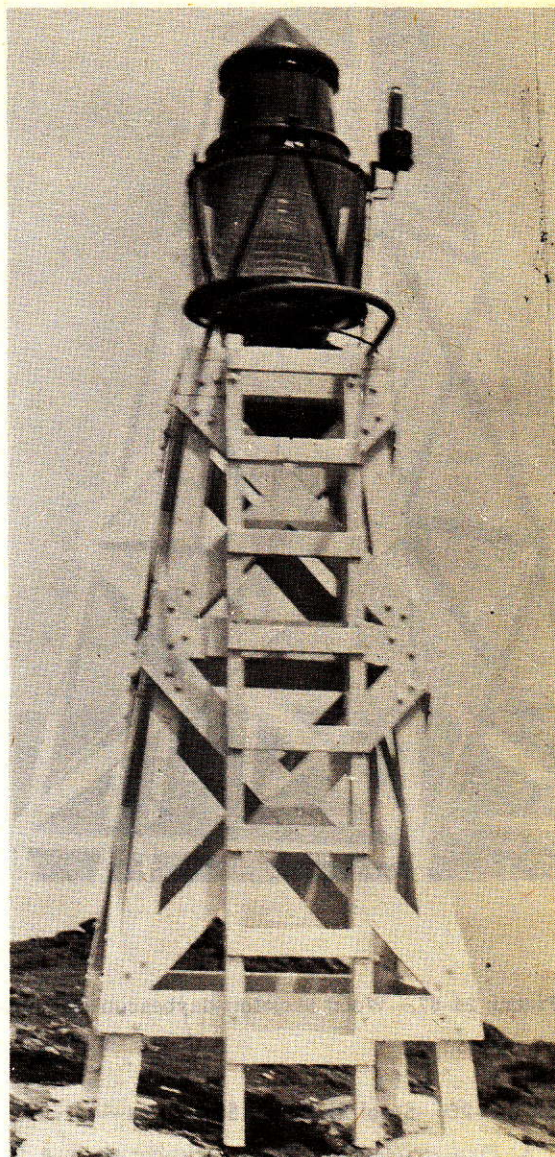

FIGURE 24-66.—Wood skeleton minor light structure on shore.

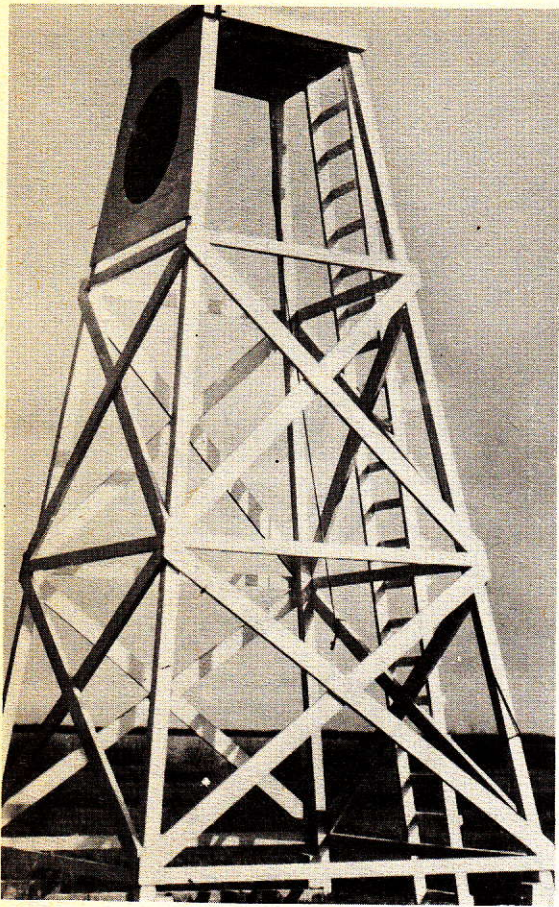

FIGURE 24-67.—Wood skeleton daybeacon on shore.

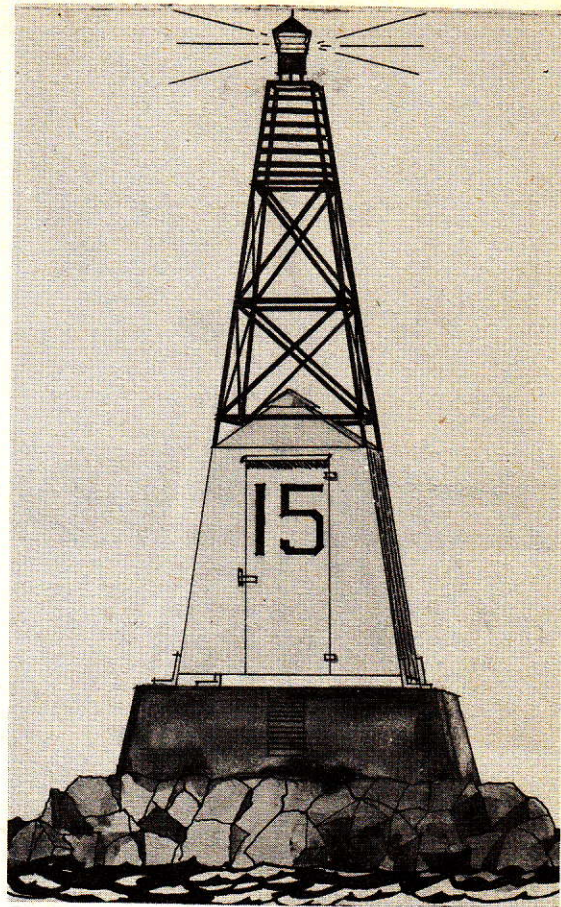

FIGURE 24-68.—Steel skeleton minor light structure on concrete foundation.

24-11-20 Steel Skeleton Structures—

A. Figures 24-68 to 24-70 inclusive show a few typical steel skeleton structures erected on concrete or steel piling foundations, or on rock riprap.

B. *Concrete foundation.*—Figure 24-68 is a tower developed for use in the Third District but also used elsewhere. This structure contains a watertight battery or tank house to which the skeleton tower is bolted. The entire structure is supported by a concrete foundation.

C. *Screw pile foundation.*—Figure 24-69 is a

wrought iron pile structure developed in the Seventh District to withstand severe hurricane exposure. The piling is of the screw pile type and is generally penetrated into coral rock to a depth of 10 to 15 feet. No new structures of this type are being erected since they were constructed entirely of wrought iron and the present cost of the necessary special fittings and labor is prohibitive.

D. *Steel shell foundation.*—Figure 24-70 is similar to figure 24-68 except that the structure is built on a steel shell filled with concrete which in turn is supported on a concrete foundation.

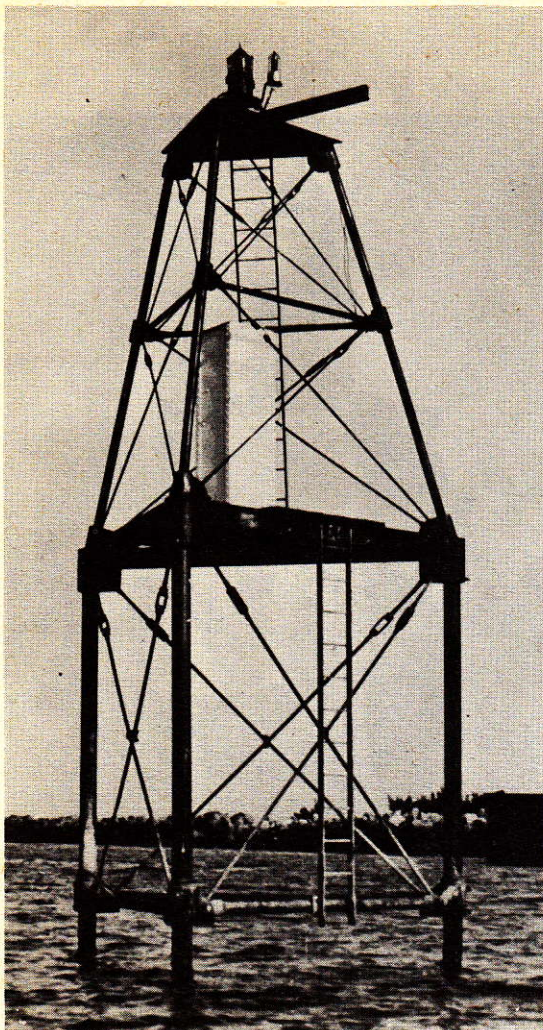

FIGURE 24-69.—Iron-pile minor light structure on marine site.

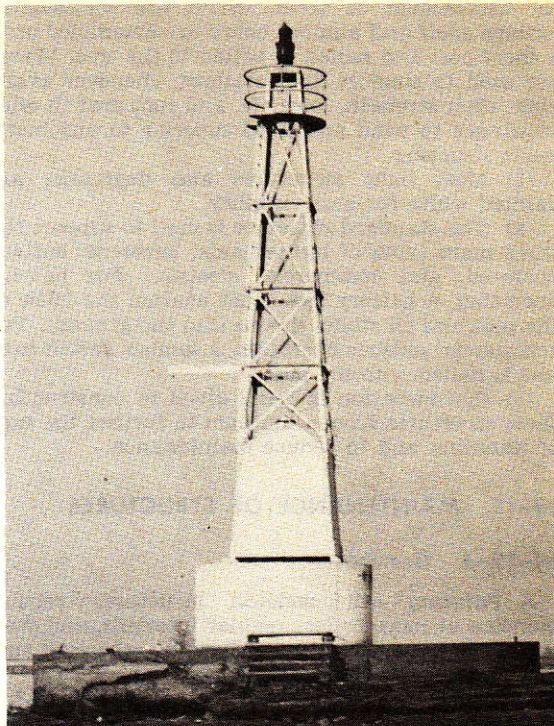

FIGURE 24-70.—Steel skeleton minor light structure on concrete-filled steel shell on concrete foundation.

24-11-25 Miscellaneous Types—

A. Figures 24-71 and 24-72 illustrate a structure used in the First District consisting of a wooden battery box erected on a concrete-filled steel caisson on a marine site.

B. Figure 24-73 shows details of a light and day-mark structure in use on the Mississippi River.

(1) On certain inland waterways, tenders anticipate structure needs and have ready at all times assembled units of (a) post, wings, and lantern shelf, and (b) the stepped ladder. All parts are given prime painting in advance of use. By this preassembly and prime painting, a station may be erected and finally painted, with all illuminating apparatus in place, in a very short while.

(2) Modifications of this standard light structure are principally (a) for concrete piers, where braces and ladder are omitted, a short post being stepped into a lumber footing bolted to the pier, and (b)

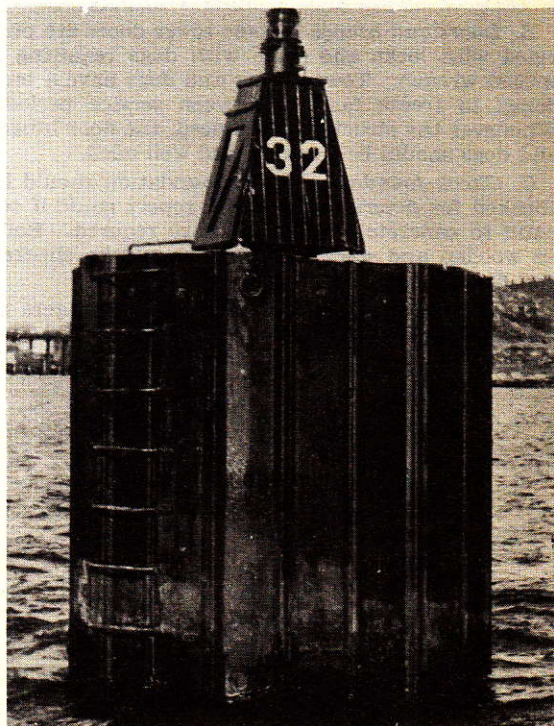

FIGURE 24-71.—Wooden battery box and lantern on concrete-filled steel caisson (First District).

for attachment to trees, where the wingboards, lantern shelf and number board are assembled onto a short post and nailed or bolted to the tree. Trees are used to support light stations whenever available; their strength, long life, and root growth offer resistance to wind and flood superior to any man-made structure.

(3) Most light structures and daymarks are painted white for best visibility.

(4) The standard structure is used to support the three main types of lighted aids; kerosene, battery operated, and commercial electric. For battery operation, a battery box is set against the back of the post and on stakes driven into the ground. For commercial electric operation, a lumber switch cabinet is nailed onto the post.

(5) Consideration is being given to constructing these structures from aluminum to further the ease of handling and to reduce maintenance.

24-12 MAINTENANCE OF STRUCTURES

24-12-1 General—

A. *Painting.*—All skeleton structures require painting at more or less regular intervals, and steel structures generally require chipping wherever rust and scale have accumulated.

(1) Areas which show rust should be thoroughly scaled and wire brushed, and primed with a coat of red lead or zinc chromate.

(2) Follow the priming coat with a water resistant enamel of the proper color. Apply the paint in a careful manner and avoid clogging tank or battery house door hinges and oil holes with paint.

B. *Doors and hinges.*—Some tower doors are provided with locks and some with dogs requiring a special wrench. Tower doors and dogs have a tendency to freeze fast in between service periods. Whenever the structure is serviced, the door hinges and dogs should be freed up and well oiled.

C. *Check foundation.*—The foundation should be checked for deterioration and a report made if repairs to concrete, riprap, etc., are required. Bolts on wooden and steel structures should be checked and drawn up if necessary.

D. Often rotted sections of wooden stringers or braces need to be cut out and replaced.



FIGURE 24-72.—Close-up view of battery box and lantern (similar to figure 24-71).

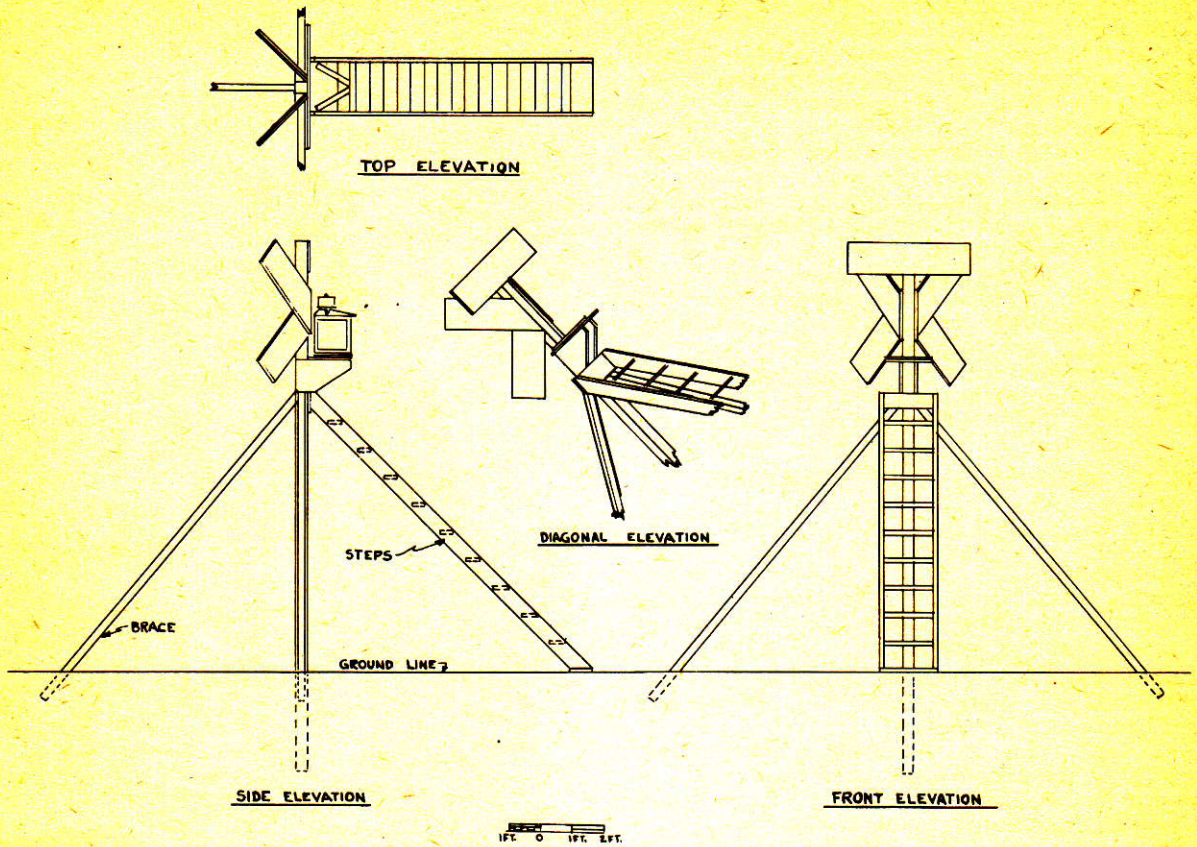

FIGURE 24-73.—Minor light and daymark structure used on Mississippi River.