

**THE SPECTRUM SHARING INNOVATION
TEST-BED PILOT PROGRAM
FISCAL YEAR 2009 PROGRESS REPORT**



**NATIONAL TELECOMMUNICATIONS AND
INFORMATION ADMINISTRATION**

**Lawrence E. Strickling, Assistant Secretary for
Communications and Information**

DECEMBER 2009

TABLE OF CONTENTS

I.	BACKGROUND.....	1
II.	PHASE I TEST PLAN.....	2
III.	OVERVIEW OF DYNAMIC SPECTRUM ACCESS.....	3
	TECHNOLOGIES	
IV.	STATUS OF PHASE I TESTING.....	4
V.	PLANNED FISCAL YEAR 2010 ACTIVITIES.....	4
	APPENDIX A: PHASE I TEST DIAGRAMS	
	APPENDIX B: DESCRIPTION OF LAND MOBILE RADIO ENVIRONMENT	

I. BACKGROUND

The National Telecommunications and Information Administration (NTIA), in coordination with the Federal Communications Commission (FCC) and the Federal agencies, has established a Spectrum Sharing Innovation Test-Bed (Test-Bed) pilot program to examine the feasibility of increased sharing between Federal and non-Federal users. This pilot program is an opportunity for the Federal agencies to work cooperatively with industry, researchers, and academia to examine objectively new technologies that can improve management of the nation's airwaves.

The Test-Bed pilot program will evaluate the ability of Dynamic Spectrum Access (DSA) devices employing spectrum sensing and/or geo-location techniques to share spectrum with land mobile radio (LMR) systems operating in the 410-420 MHz Federal band and in the 470-512 MHz non-Federal band.¹ To address potential interference to incumbent LMR spectrum users, the Test-Bed pilot program will include both laboratory and field measurements performed in three phases to characterize the interaction with DSA enabled devices:

Phase I – Equipment Characterization. Equipment employing DSA techniques will be sent to the NTIA Institute for Telecommunication Sciences (ITS) in Boulder, Colorado to undergo characterization measurements of the DSA capabilities in response to simulated environmental signals.

Phase II – Evaluation of Capabilities. After successful completion of Phase I, the DSA spectrum sensing and/or geo-location capabilities of the equipment will be examined in the geographic area of the Test-Bed.

Phase III – Field Operation Evaluation. After successful completion of Phase II, the DSA equipment will be permitted to transmit in an actual radio frequency signal environment. An automatic signal logging capability will be used during operation of the Test-Bed to help resolve interference events if they occur. A point-of-contact will also be established to stop Test-Bed operations if interference is reported.

NTIA selected the following parties to participate in the Test-Bed pilot program: Adapt4 LLC, Adaptrum Inc., BAE Systems, Motorola Inc., Shared Spectrum Company, and Virginia Polytechnic Institute and State University.

This progress report describes the activities related to the Test-Bed pilot program undertaken during Fiscal Year 2009.

1. Dynamic Spectrum Access technology allows a radio device to (i) evaluate its radio frequency environment using spectrum sensing, geo-location, or a combination of spectrum sensing and geo-location techniques, (ii) determine which frequencies are available for use on a non-interference basis, and (iii) reconfigure itself to operate on the identified frequencies.

II. PHASE I TEST PLAN

NTIA completed the coordination of the Phase I test plan with the Test-Bed participants in November 2008 and published the coordinated Phase I test plan in the Federal Register for public review and comment in December 2008.² NTIA addressed the public comments on the test plan and published a final version on the NTIA website in February 2009.³

The Phase I test plan breaks the test cases down into five categories for each Device Under Test (DUT): emission characterization, sensor characterization, spectrum access behavior, LMR emission characterization, and LMR receiver performance characterization. An overview of the proposed test cases to be performed under Phase I is shown in Figure 1. All Phase I testing will be performed at the ITS laboratory.

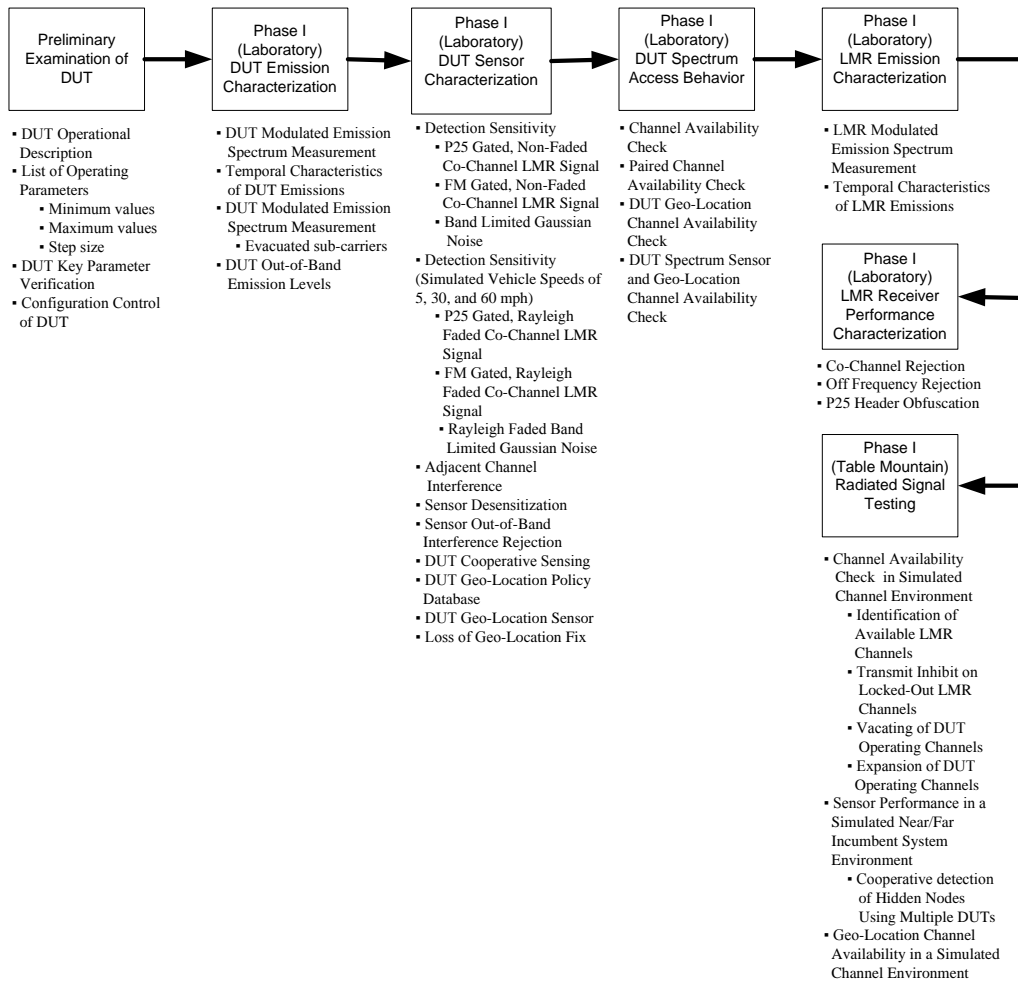

Figure 1.

2. Spectrum Sharing Innovation Test-Bed Pilot Program, 73 Fed. Reg. 76,002 (Dec. 15, 2008).

3. The final Phase I test plan and additional information on the Test-Bed pilot program is available at <http://www.ntia.doc.gov/ntiahome/frnotices/2006/spectrumshare/comments.htm>.

An overview of the general measurement configurations to be used in the Phase I testing is provided in Appendix A.

III. OVERVIEW OF DYNAMIC SPECTRUM ACCESS TECHNOLOGIES

In the process of preparing the final test plan for Phase I, NTIA staff members met with each of the Test-Bed participants to discuss their DSA devices. Based on the information provided by the participants, a high level overview of the different DSA implementations being considered in the Test-Bed pilot program is provided in Table 1.

Table 1.

Parameter	Test-Bed Participants					
	A	B	C	D	E	F
DSA Capabilities	Spectrum Sensing and Geo-Location	Spectrum Sensing	Spectrum Sensing	Spectrum Sensing	Spectrum Sensing and Geo-Location	Spectrum Sensing
Transmit Bandwidth	Fixed	Variable	Variable	Fixed	Fixed	Fixed
Channel Structure	Contiguous Channels	Non-Contiguous Channels	Non-Contiguous Channels	Single Channel	Single Channel	Single Channel
Monitoring Frequency Range	Variable	Fixed	Fixed	Fixed	Fixed	Fixed
Monitoring Time	Variable	Variable	Variable	Variable	Variable	Variable
Duplex Channel Monitoring Capability	Yes	No	No	No	No	No
Detection Method	Power Level Exceeding Threshold	Power Level Exceeding Threshold	Power Level Exceeding Threshold	Statistical Processing	Power Level Exceeding Threshold	Power Level Exceeding Threshold
Detection Threshold	Variable	Variable	Variable	Variable	Variable	Variable
Detection Time	Variable	Variable	Variable	Variable	Variable	Variable
Cooperative Sensing Capability	Yes	Yes	No	Yes	No	No
Feature Detection Capability	No	No	Yes	No	No	No
Control Channel	No	Yes	No	No	No	No
Channel Lock-Out Capability	Yes	Yes	Yes	Yes	Yes	Yes
Channel Clearance Time	Variable	Variable	Variable	Variable	Variable	Variable
Channel Re-Visit Time	Variable	Variable	Variable	Variable	Variable	Variable
Automatic Transmit Disable Capability	Yes	Yes	Yes	Yes	Yes	Yes

During the meetings with NTIA, the participants asked questions related to how the Test-Bed frequency bands are used. Appendix B provides a description of the types of LMR systems that are used in the 410-420 MHz band.⁴ Appendix B also discusses technical parameters from the Government Master File (GMF) and presents LMR channel occupancy measurements.⁵

IV. STATUS OF PHASE I TESTING

In order to facilitate the collection of the data specified in the test plan, NTIA requested that special output modes be added to the DSA devices. Additional time was needed to modify the initial DSA device, delaying the delivery of the device to ITS by several months.

The ITS laboratory received the first DSA device in March 2009. The Test-Bed participants provided training on the use of their device and pertinent documentation. Although NTIA initially estimated that it would take four months to complete the testing for each DSA device, the first DSA device has taken longer than anticipated. There were several instances in which because of the operational capabilities of the DSA device, NTIA had to significantly revise the test procedure. There were also instances where NTIA performed additional testing to examine unexpected behavior of the DSA device. Approximately 75 percent of the Phase I laboratory testing for the first device has been completed. The Phase I laboratory testing for the first DSA device should be completed in December 2009.

The ITS laboratory received a second DSA device in August 2009. The Test-Bed participants provided training and answered questions related to their DSA device. NTIA initiated the Phase I laboratory testing of the second DSA device in November 2009.

The current schedule for the Phase I testing is shown in Table 2.

Table 2.

Test-Bed Participant	Tentative Start Date
A	March 2009
B	November 2009
C	April 2010
D	October 2010
E	April 2011
F	October 2011

4. National Telecommunications and Information Administration, NTIA Report 06-440, *Federal Land Mobile Operations in the 162-174 MHz Band in the Washington, D.C. Area Phase 1: Study of Agency Operations* (Aug. 2006) Section 3, at http://www.ntia.doc.gov/osmhome/reports/2006/Land_Mobile_DC_06_440.pdf.

5. The GMF contains records of the frequencies assigned to all federal agencies in the United States and its possessions.

V. PLANNED FISCAL YEAR 2010 ACTIVITIES

The Phase I laboratory testing will continue based on the schedule shown in Table 2. After coordinating the test results with the Test-Bed participants, NTIA will draft and coordinate with the federal agencies on the Interdepartment Radio Advisory Committee, an interim report documenting the results.⁶ The interim report will be published in the Federal Register for public review and comment. The testing at the ITS Table Mountain facility will begin after the laboratory testing has been completed for each DSA device. NTIA will begin developing a test plan for Phase II and III that will be coordinated with the federal agencies, Test-Bed participants, and the public. NTIA will also develop analytical capabilities to assess the potential interference to LMR systems from DSA devices.

6. The IRAC, consisting of representatives of 20 federal agencies, serves in an advisory capacity to the Assistant Secretary of Commerce for Communications and Information.

APPENDIX A PHASE I TEST DIAGRAMS

This appendix presents general diagrams for the different test cases described in the Phase I test plan. The diagrams will be modified based on the operation of the individual Dynamic Spectrum Access Device Under Test (DUT). All of the sensor characterization and spectrum access behavior tests were performed in a radio frequency enclosure.

Figure A-1 is the general diagram for the DUT modulated emission spectrum measurement, temporal characteristics of DUT emissions, and DUT modulated emission spectrum measurement.

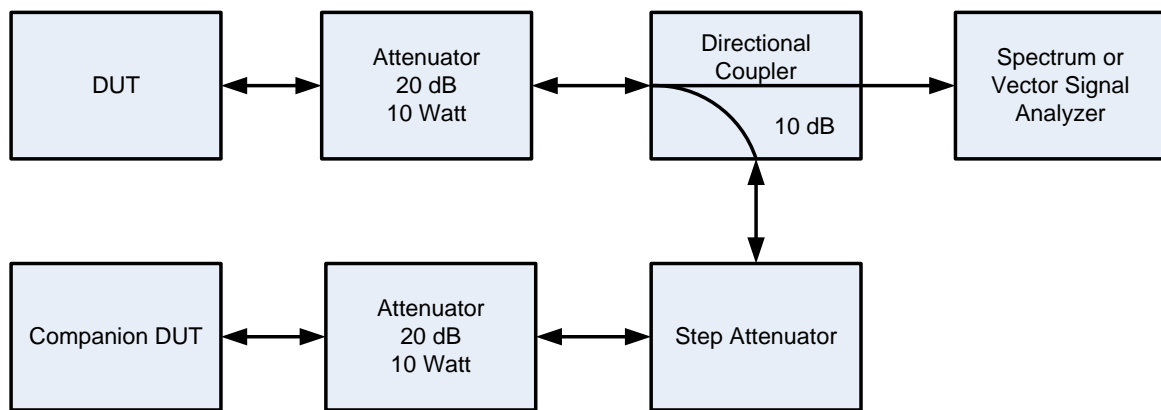

Figure A-1.

Figure A-2 is the general diagram for the DUT out-of-band emission level measurements.

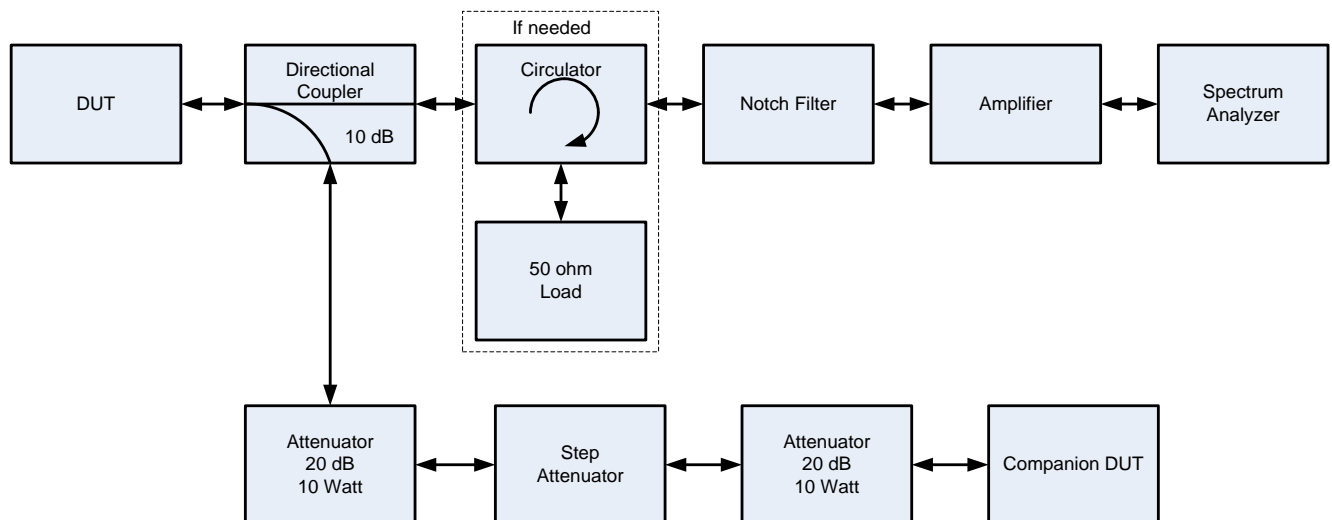

Figure A-2.

Figure A-3 is the general diagram for the detection sensitivity for non-faded, co-channel land mobile radio (LMR), and noise signal (channel availability check mode) measurements.

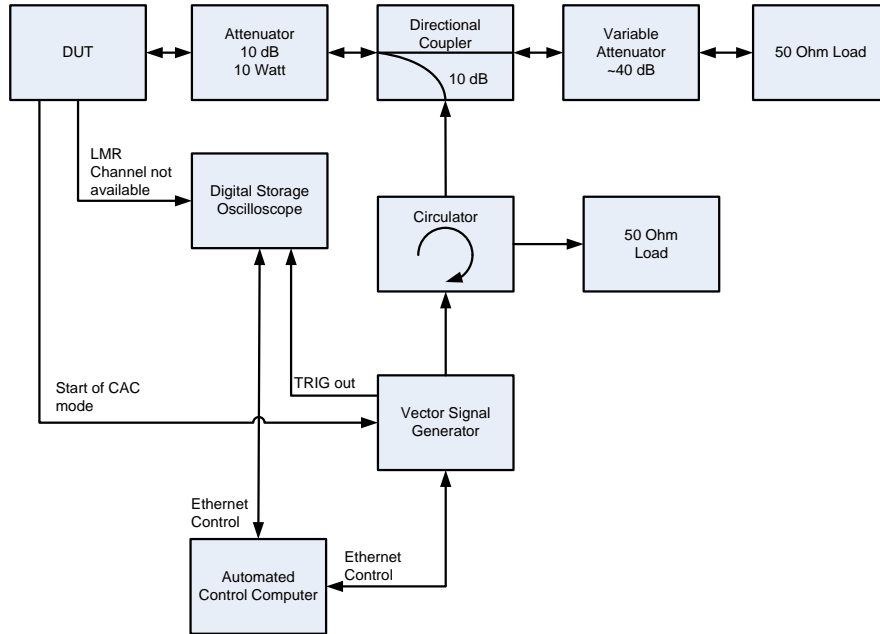

Figure A-3.

Figure A-4 is the general diagram for the detection sensitivity for non-faded, co-channel LMR, and noise signal (in-service monitoring mode) measurements.

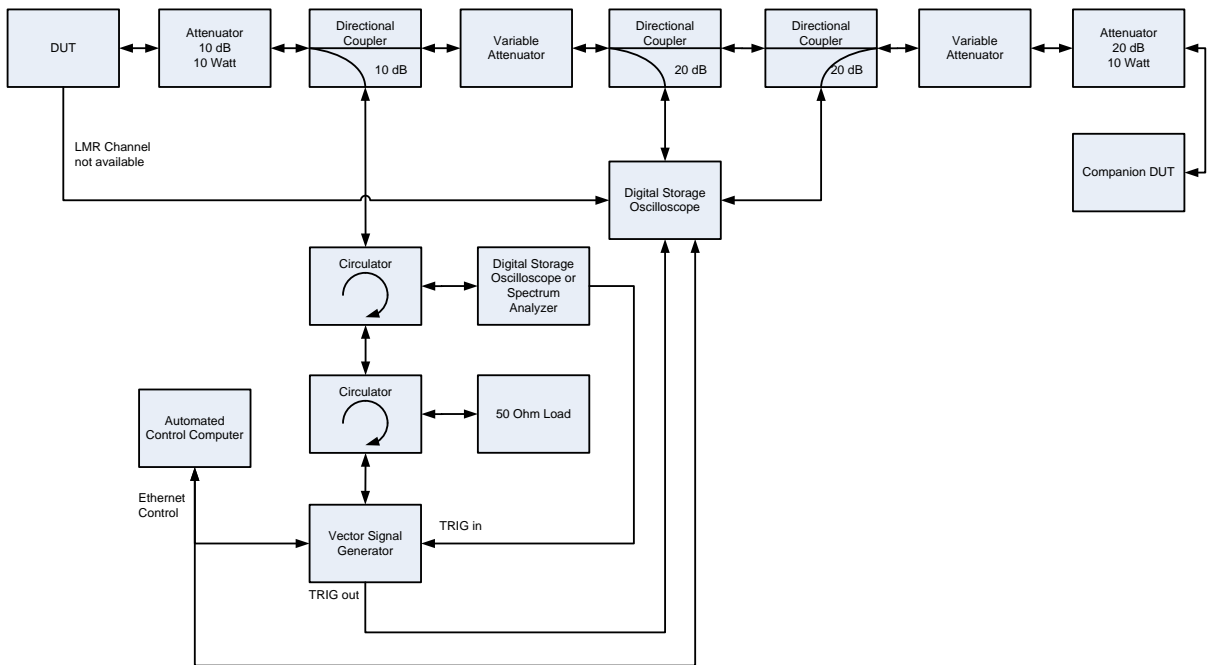

Figure A-4.

Figure A-5 is the general diagram for the detection sensitivity for faded, co-channel LMR, and noise signal (channel availability check mode) measurements.

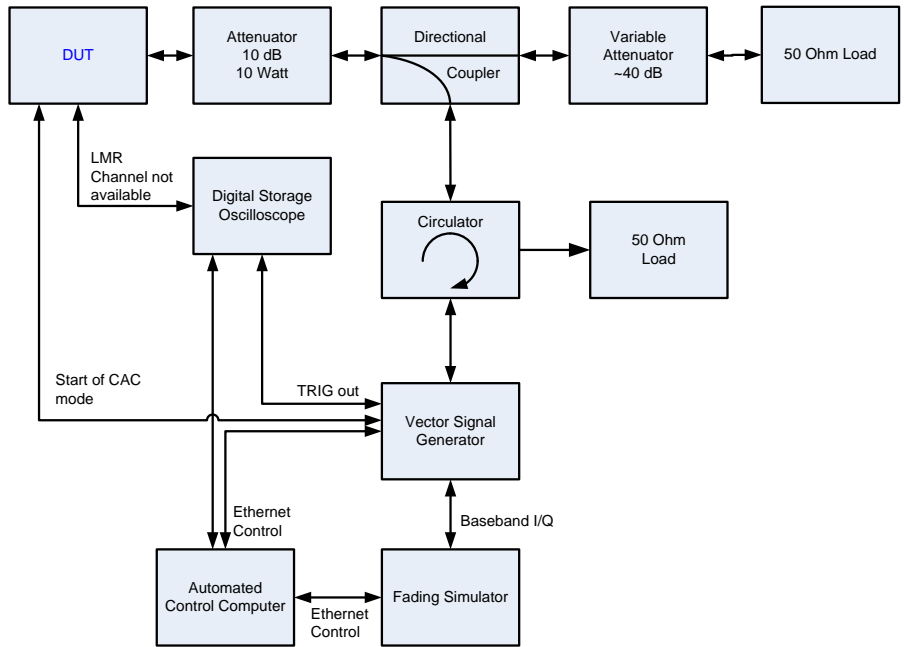

Figure A-5.

Figure A-6 is the general diagram for the detection sensitivity for faded, co-channel LMR, and noise signal (in-service monitoring mode) measurements.

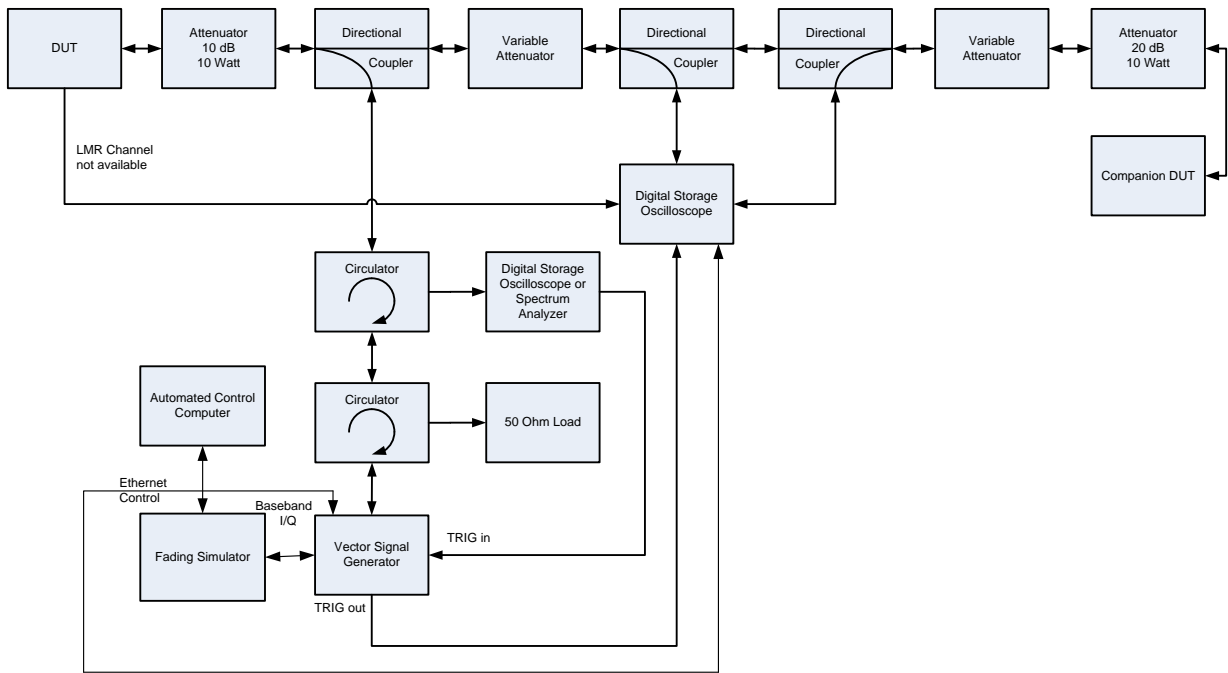

Figure A-6.

Figure A-7 is the general diagram for the adjacent channel interference (channel availability mode) measurements.

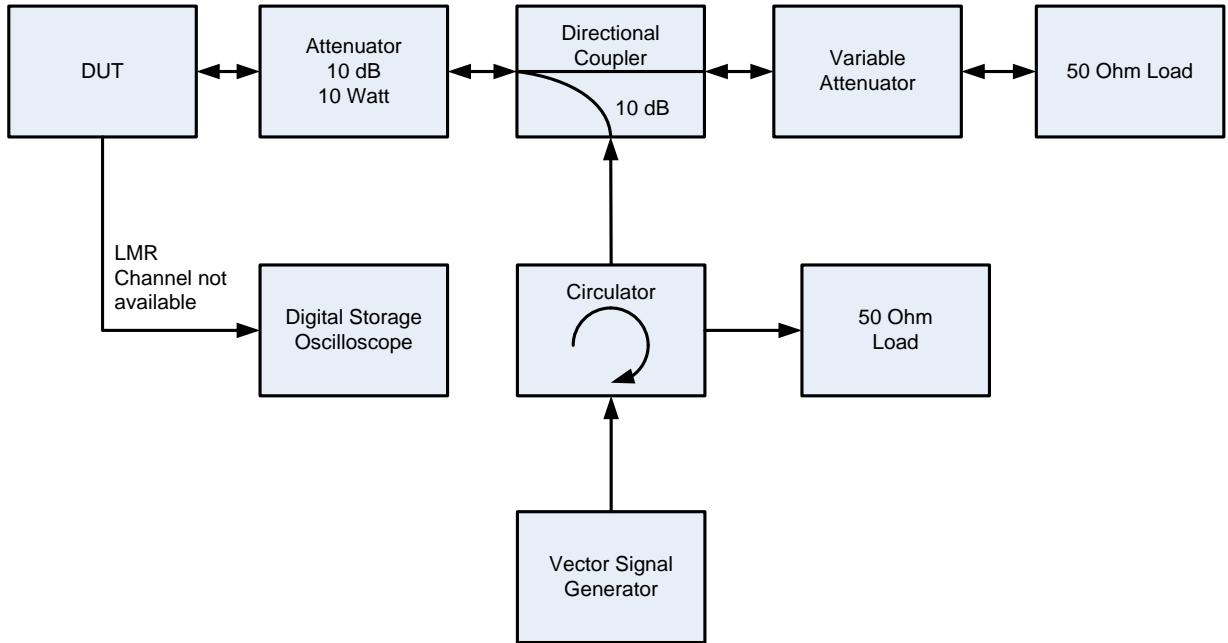

Figure A-7.

Figure A-8 is the general diagram for the adjacent channel interference (in-service monitoring mode) measurements.

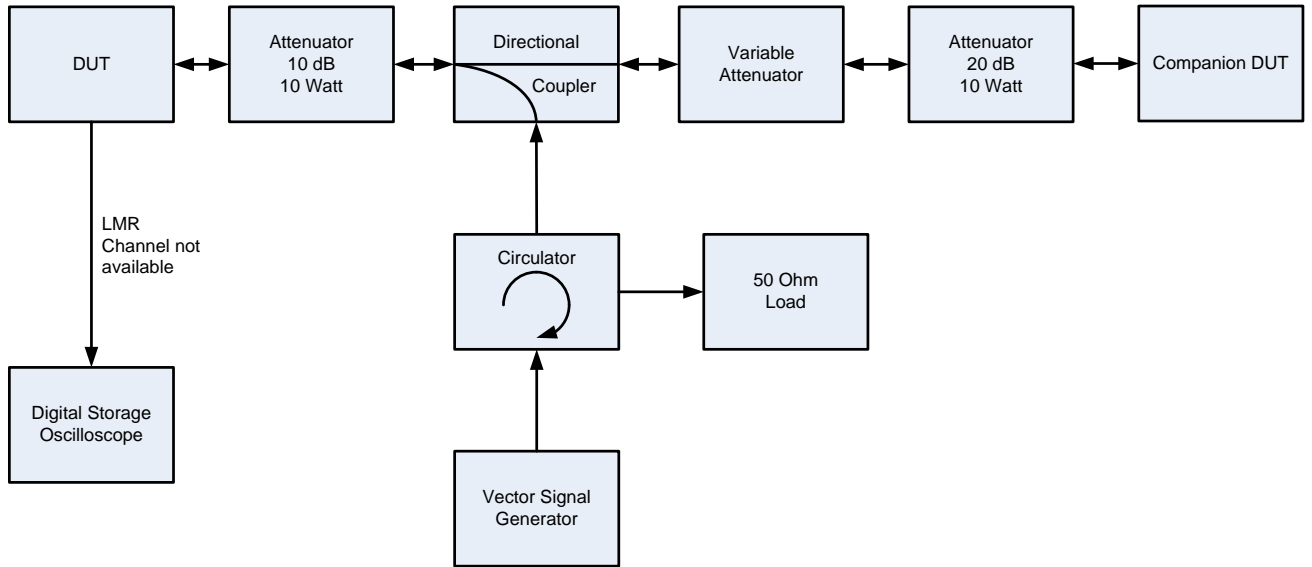

Figure A-8.

Figure A-9 is the general diagram for the sensor desensitization and sensor out-of-band interference rejection (channel availability check mode) measurements.

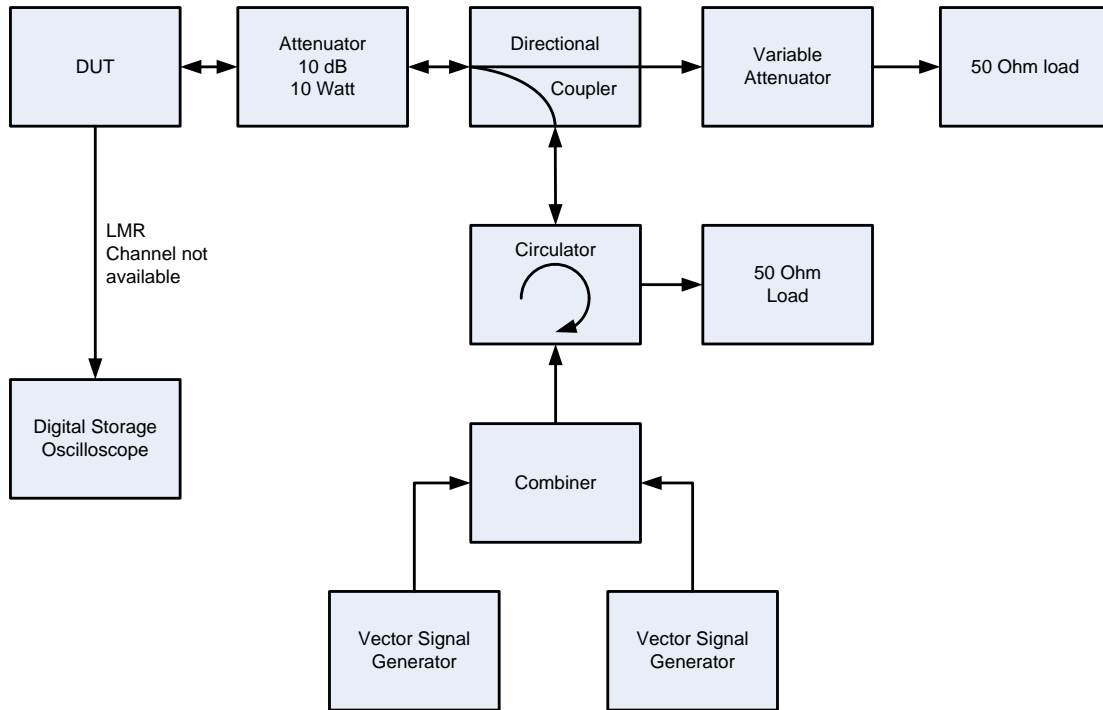

Figure A-9.

Figure A-10 is the general diagram for the sensor desensitization and sensor out-of-band interference rejection (in-service monitoring mode) measurements.

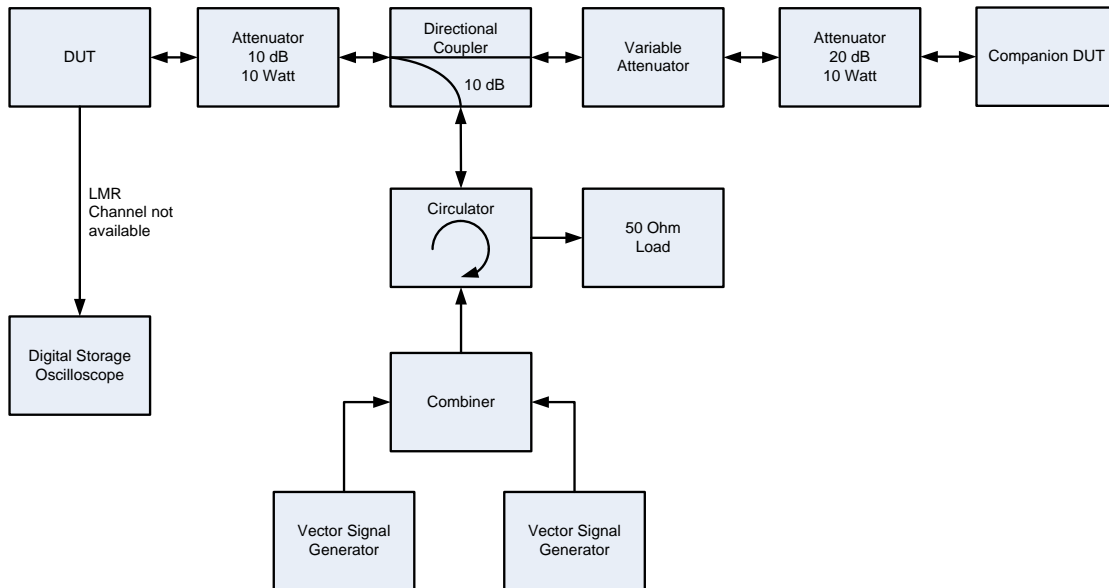

Figure A-10.

Figure A-11 is the general diagram for the cooperative sensing and paired-channel availability check measurements.

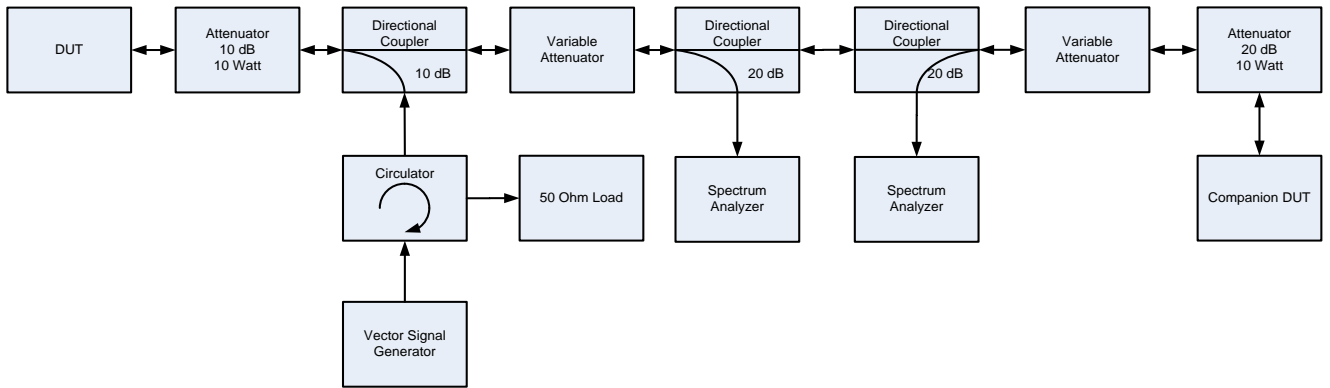

Figure A-11.

Figure A-12 is the general diagram for the geo-location policy database measurements.

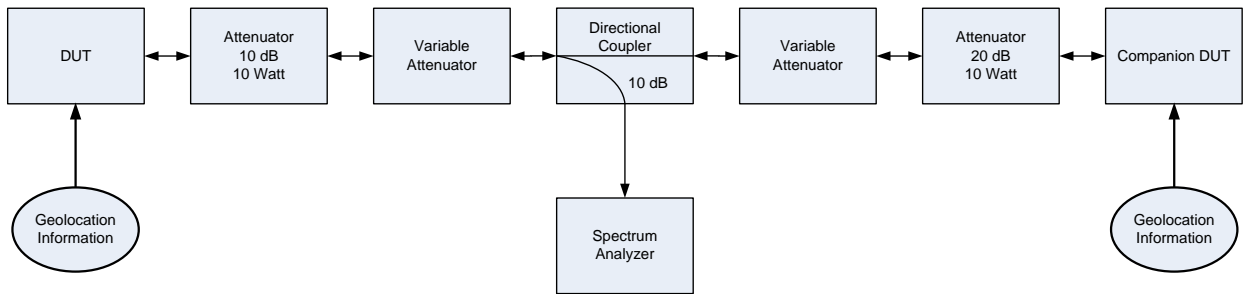

Figure A-12.

Figure A-13 is the general diagram for the geo-location sensor and loss of geo-location fix measurements.

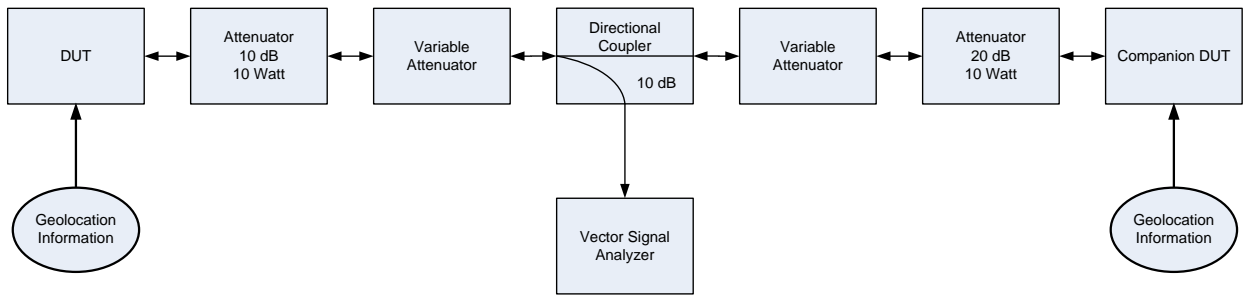

Figure A-13.

Figure A-14 is the general diagram for the channel availability check measurements.

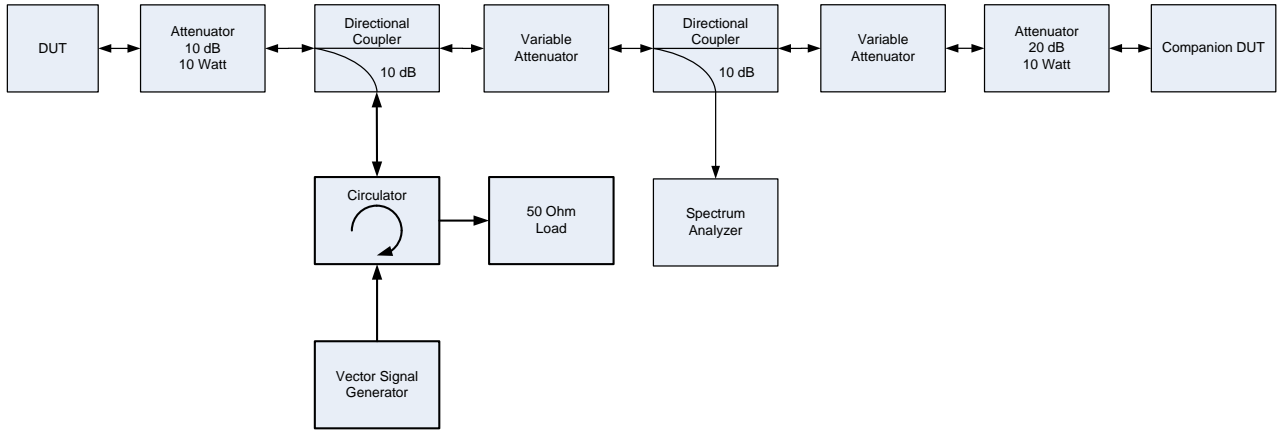

Figure A-14.

Figure A-15 is the general diagram for the geo-location channel availability check measurements.

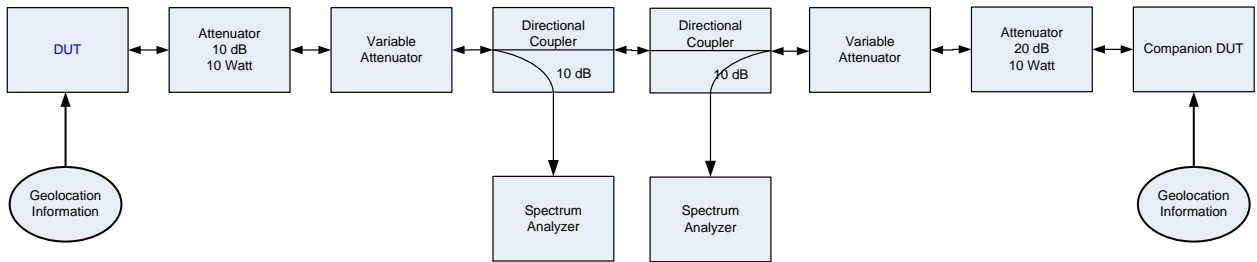

Figure A-15.

Figure A-16 is the general diagram for the spectrum sensor and geo-location channel availability check measurements.

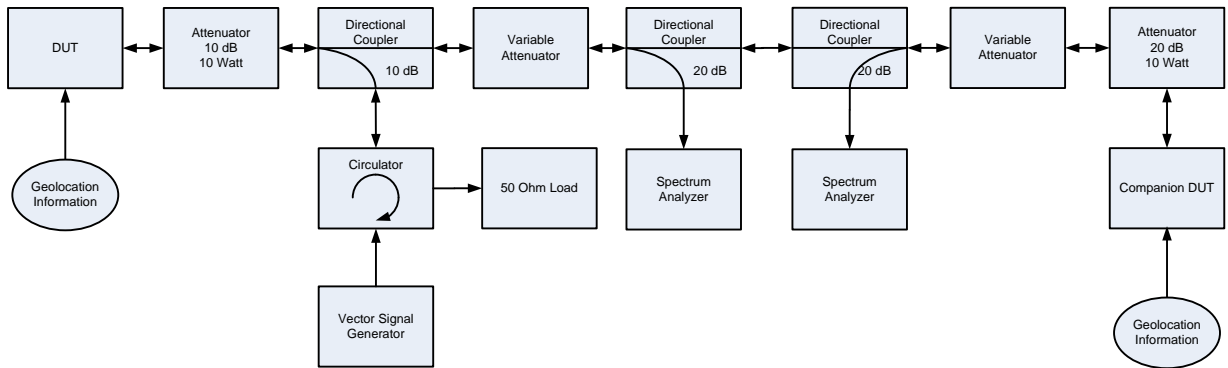

Figure A-16.

Figure A-17 is the general diagram for the LMR modulated emission spectrum measurements.

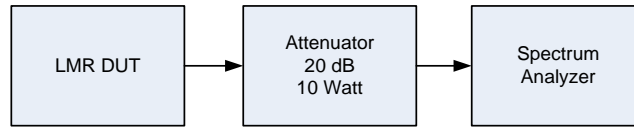

Figure A-17.

Figure A-18 is the general diagram for the temporal characteristics LMR modulated emission measurements.

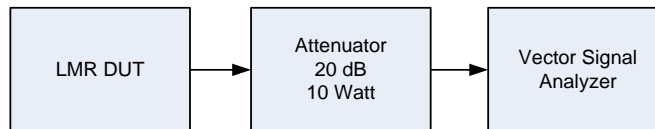

Figure A-18.

Figure A-19 is the general diagram for the LMR receiver co-channel rejection and LMR receiver off frequency rejection measurements.

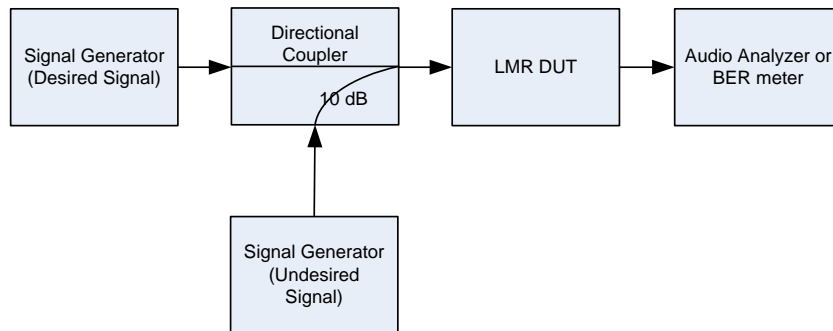

Figure A-19.

Figure A-20 is the general diagram for the Project 25 header obfuscation measurements.⁷

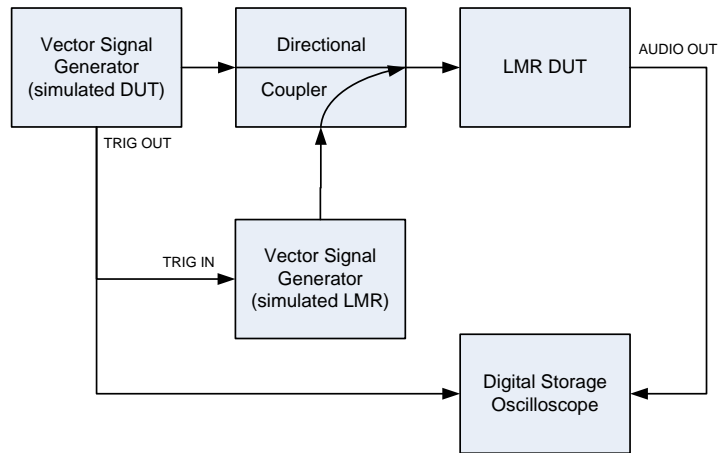

Figure A-20.

7. The Project 25 standards apply to conventional and trunked base, mobile, and portable systems. The standards are published in the Telecommunications Industry Association/Electronics Industries, Alliance, an American National Standards Institute accredited process. For example, see <http://www.ANSI.org>.

APPENDIX B DESCRIPTION OF LAND MOBILE RADIO ENVIRONMENT

This appendix provides a description of the types of LMR systems that are used in the 410-420 MHz band.¹ This appendix also discusses technical parameters from the Government Master File (GMF), the current channel plan and presents LMR channel occupancy measurements.²

DESCRIPTION OF LMR SYSTEMS

Simplex Radio Systems

A simplex radio system is most likely the simplest type of radio system, and is the first type of system that was widely used by radio users. In simplex systems, the user transmits and receives on the same frequency. Figure B-1 shows a typical simplex radio system, composed of various mobile radio users, M_1 - M_6 , and a base station, B. A typical user listens to the traffic, if any, transmitted by the other users, and the base station, as shown in Figure B-1(A). If a given mobile user wants to talk with any, or all, of the other users, the user waits until no other user is speaking, then presses the “push-to-talk” button on the microphone and talks. This causes the radio to shift from “receive” mode to “transmit” mode, and the other radios tuned to that frequency receive the transmitted signal (e.g., M_5 is shown transmitting in Figure B-1(B)).

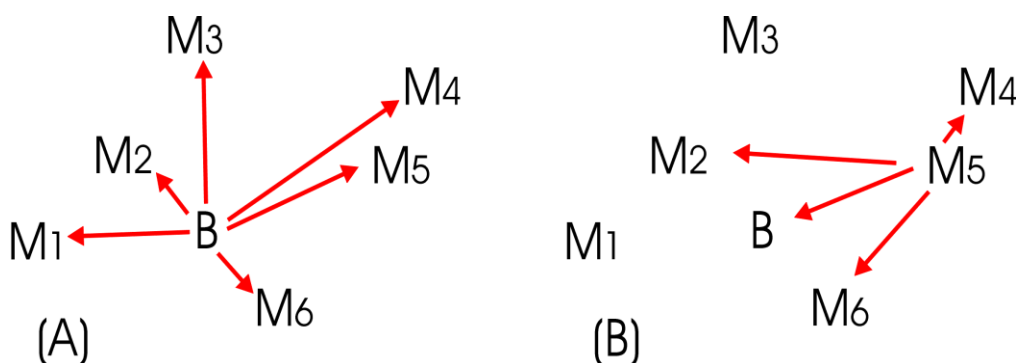

Figure B-1. Simplex Radio System

Within a simplex radio system, base stations are functionally equal to any of the mobile stations, except that base stations are in fixed locations and typically have more transmitter power and a more advantageously-placed antenna (e.g., at the top of a high tower near the communications center). This often gives a high-power, high-elevation

1. National Telecommunications and Information Administration, NTIA Report 06-440, *Federal Land Mobile Operations in the 162-174 MHz Band in the Washington, D.C. Area Phase 1: Study of Agency Operations* (Aug. 2006) Section 3, at http://www.ntia.doc.gov/osmhome/reports/2006/Land_Mobile_DC_06_440.pdf.

2. The GMF contains records of the frequencies assigned to all federal agencies in the United States and its possessions.

base station the ability to “talk” further than typical low-power, low elevation mobile stations.

The situation is generally worse for communications between mobile users, where both the receiving and transmitting locations are lower and the radio paths between them are much more likely to be blocked by terrain and other obstacles. In Figure B-1(B), the signal from M_5 , possibly because of terrain blockage between M_3 and M_5 , or by M_1 , possibly because of excessive distance. Thus, the number of users that can participate in a conversation may depend greatly on the location of the specific user that is transmitting. This situation can cause various problems. For example, in Figure B-1(B), M_3 and M_5 may be transmitting at the same time, each unaware that their messages are interfering with each other in the receivers of other listeners. A given mobile talker may not know whether the transmitted message has been received by another mobile listener. A critical mobile-to-mobile message may need to be relayed to a distant mobile user by the base station or by an intervening mobile user.

Radio Repeater Systems

Repeater architecture, shown in Figure B-2, is used especially to solve some of the problems associated with the limited and variable mobile-to-mobile communications range that is inherent in the simplex system. The high tower or mountaintop base station is called a “repeater” and is labeled with an “R” in Figure B-2. There are two major changes from the simplex architecture. First, the repeater, unlike the base station, does not originate or terminate any messages. Second, the repeater continuously listens on frequency F_2 (dashed arrow), and simultaneously transmits whatever it receives on a second frequency, F_1 (solid arrow). The mobile units use the same two frequencies reversed in function (i.e. mobile units continuously listen on F_1 and occasionally transmit on the frequency F_2).

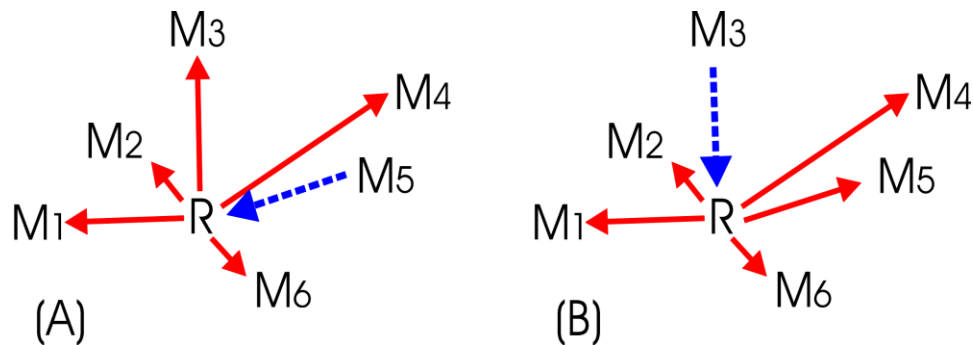

Figure B-2. Repeater Architecture

At a given instant (e.g., when mobile user M_5 is transmitting on F_2), the other users, shown in Figure B-2(A) are listening on frequency F_1 . These mobile users hear the signal on F_1 that was originally transmitted at F_2 from M_5 and re-transmitted by the repeater at F_1 . The important feature of the repeater architecture is that the ability of mobile users to communicate with each other depends entirely on how well the mobile

users communicate with the repeater, instead of the often problematic direct path between mobile users.

Since the repeater site is typically chosen to provide low-path-loss propagation to a large geographic area, the usable mobile-to-repeater coverage is much greater than typical mobile-to-mobile coverage. Therefore, even though an intervening hill might prevent M_3 from hearing M_5 directly, they can communicate via the hilltop repeater site.

A primary user (e.g., a dispatcher at M_3) does not need to connect directly to the repeater site, but only needs radio contact with the repeater site, like any of the mobile users. This encourages placement of the repeater site on the top of a distant high tower or mountaintop, rather than being constrained to being close to the physical location of the communications center (e.g., downtown).

The use of separate transmit and receive frequencies for mobile users also solves a major equipment design problem, since mobile radios can be built with the assumption that all possible receive frequencies will be in one frequency band segment, while all possible transmit frequencies will be in a separate band segment. This simplifies the design of the radios, while permitting greater flexibility in tuning among many possible frequency channels. Simplex radios cannot depend on those critical design simplifications and traditionally have only a few channels of operation.

Mobile Talk-Around Mode

One disadvantage of the repeater architecture is that all communications must pass through the repeater. If the repeater site malfunctions or if mobile units drive out of range of the repeater site, communications will cease, no matter how close together the mobile units may be to one another. There are various methods of solving these problems. For example, in some systems it may be practical to switch to a “talk around” mode where closely-spaced mobile users switch to a simplex mode and communicate directly with each other using frequency F_2 , independent of the base or repeater station. Although such talk-around operation has all of the range limitations associated with mobile-mobile simplex operations, it provides a very useful alternative mode that often extends the useful range of operations outside the normal repeater range.

Multi-Site Repeater Systems

The coverage area served by a single repeater site can be increased by using multiple repeater sites. A two site example is shown in Figure B-3. A signal will be repeated by repeater R_1 if the mobile unit is within range of repeater R_1 or by repeater R_2 if the mobile transmitter is within range of repeater R_2 . Unfortunately, if a mobile unit is within range of both R_1 and R_2 (e.g., M_5 in the Figure B-3), a signal will be transmitted by both R_1 and R_2 . Simultaneous R_1 and R_2 signals that are received at about the same signal strength and frequency by any mobile users (e.g., M_1 and M_6 in the Figure B-3) can cause interference, which prevents the signal from being properly received. A discussion of simulcast systems, which are specially designed to prevent this problem, is provided later in this section. However, some multiple repeater systems attempt to negate this

problem by locating/adjusting repeaters so they cause a minimum amount of such interference.

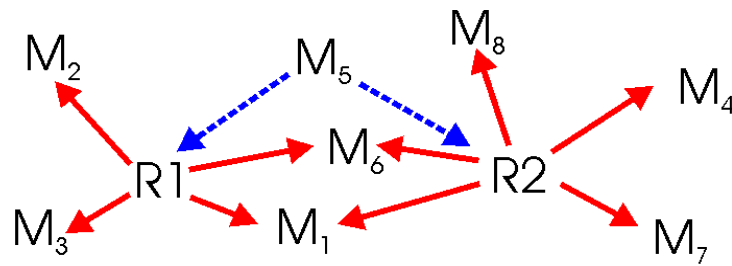

Figure B-3. Multi-Site Repeaters

One way to avoid the interference problem is to use different transmit frequencies at the repeater sites. Unfortunately, this solution also requires that the mobile users adjust their receiver frequencies to match the transmitted frequency of the local repeater site. This adds some inconvenience for a mobile user. Another way to avoid simulcast interference is to add a continuous tone-coded squelch system (CTCSS) signal to the mobile voice transmission. The various codes that can be transmitted by CTCSS can be used to “activate” individual repeater sites, so that only the selected site is caused to repeat the message. The user would have several selectable channels on the mobile radio, all of which used identical frequencies but transmitted different CTCSS codes. By selecting a particular channel, the user can select which repeater site to activate.

The use of different repeater transmitter frequencies, versus the use of activating different sites with CTCSS codes, has various operational advantages and disadvantages. The use of CTCSS codes allows mobile users to operate everywhere using the same pair of frequencies. This means that mobile users do not need to switch continually frequencies depending on their location relative to the various repeater sites. The use of CTCSS also requires many fewer frequencies. However, if the repeater sites are used individually (i.e., if an incoming mobile message received at one site is not simultaneously repeated from all sites), the use of individual repeater transmit frequencies may allow more independent messages to be repeated from a set of repeater sites.

Half-Duplex Radio Systems

The half-duplex architecture combines elements of the simplex and the repeater architectures, as shown in Figure B-4. As with the simplex system technology, half-duplex technology has a base station talking to multiple mobile users and receiving signals from these users. Like the repeater system, a half-duplex system transmits messages from the base station to the mobile users, Figure B-4(A), at one frequency F_1 (solid line) and receives messages, Figure B-4(B), from mobile users at another frequency F_2 (dashed line). The primary functional difference between half-duplex and repeater architectures is that half-duplex base stations are directly linked to fixed

communications networks, dispatchers, or a command center with wire-line or radio links.

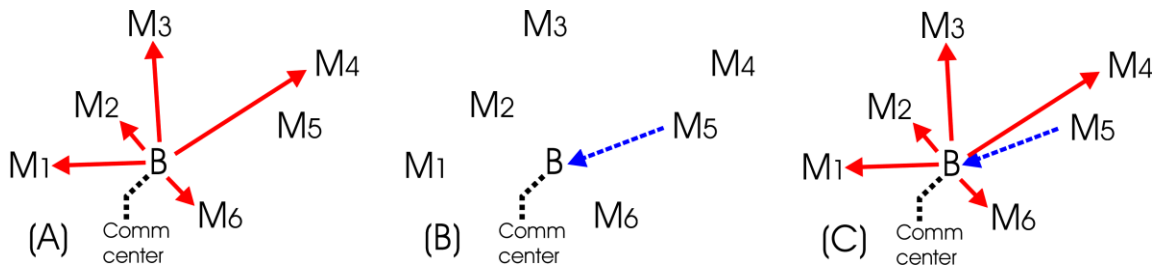

Figure B-4. Half-Duplex Radio System

From a functional point of view, most half-duplex system messages originate or terminate at the base station, whereas all repeater messages originate and terminate at a distant mobile user. Since half-duplex system messages usually originate at the base station, mobile-to-base frequency F_2 and base-to-mobile frequency F_1 do not necessarily have to simultaneously transmit the same information, which allows some additional useful modes of operation. Messages can be sent from the base station to mobile users, with no activity in the mobile-to-base channel, Figure B-4(A). Messages sent from the mobile users can be directed toward only the base station listeners (Figure B-4(B)) or they can also be re-transmitted simultaneously to all users on frequency F_1 (Figure B-4(C)) like a repeater system. So-called “full-duplex” capabilities simultaneously use F_1 and F_2 to provide full-time two-way voice communications, without the need for a push-to-transmit control (i.e., cell phone systems are full-duplex). A full-duplex capability also provides the ability for a mobile user to transmit a message to the dispatcher, without waiting for the end of an ongoing message from the dispatcher. However, many portable/mobile radios do not have the ability to simultaneously transmit and receive, so these radios could not provide full-duplex operation.

Multi-Site Duplex Systems

Multiple duplex base stations can be combined together into networks, providing a coverage area that represents the cumulative coverage area of the multiple individual base stations. Large multi-site duplex systems often have the ability for the user to enter the system at any base station site to gain access to a dispatcher at a communications center, to connect to the telephone system, or to connect to another base station coverage area at a distant location. Although multi-site systems can provide a wide range of services and coverage area, they often also require a high degree of user knowledge and attention. For example, each base station will use different frequencies, and the user must continually change transmit and receive frequencies when moving from the coverage area of one site to another site. Similarly, a user might contact a distant user by using a distant base station to provide the needed radio link; however, this could only be accomplished if the current location of the distant user was known so that the correct base station could be selected.

Although a simplex channel provides two-way voice service using only half as many frequencies needed by a duplex system, the duplex architectures have some substantial advantages over simplex radios. The main reason is that, although simplex radios operate well by themselves for many purposes, they do not operate well within groups of other similar radios. A simplex radio transceiver must be able to receive at the same frequency that it transmits. A group of simplex transceivers (e.g., at a base station shared with 20 other simplex channel users) would need to have the ability to receive a signal simultaneously with 20 other users transmitting on the same antenna tower at nearby frequencies. This turns out to be extremely difficult from a technological basis. Even one nearby (in frequency and location) transmitter will overload the receiver front-end circuits and prevent reception, and combinations of transmitters will generate interfering intermodulation products at many unintended frequencies. Thus, sharing base station facilities with large numbers of other transmitters is difficult using simplex technology.

Duplex technology uses different frequency band segments for mobile and base station transmitters (e.g., the lower half of an LMR band is used for mobile transmitters and the upper half of the band is used for base station transmitters, with a fixed frequency separation between the corresponding base and mobile paired frequencies). This greatly simplifies the construction of radio transceivers and allows much easier sharing of base station sites. Repeating the earlier scenario of sharing a base station with 20 other radio systems means the 20 other transmitters are now all in a different frequency band from that used by the receiver, and there are far fewer restrictions on how the base station can be shared. It is much easier to construct receivers and transmitters that can tune across a whole band with hundreds of different frequency pairs (channels). Moreover, this easy sharing and channel flexibility extends to ad hoc mixtures of radios, such as might occur when multiple agencies deploy their systems in the vicinity of any major emergency. When the overall usefulness of simplex and duplex systems is considered, the greater freedom to use arbitrary duplex channels for many operational situations is often more important than the implicit efficiency of the single duplex channel in isolated circumstances

Receive-Only Systems

Duplex systems may, like repeater systems, have substantial problems with unequal effective operational ranges for mobile and portable radios versus the base station site. In many systems where reception is required for portable radios, especially for portable radios operating inside buildings, the problem of unequal range is solved by adding “receive-only” (RO) base stations as shown in Figure B-5.

These additional RO base stations are located so that a base station receiver is always within the transmitting range of even lower power portable radios. Typically, the received audio from each of the receiver sites, RO and two-way, are transferred to a central point (e.g., the dispatcher or

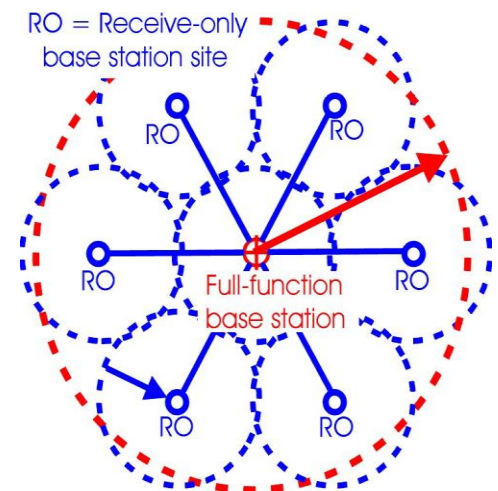

Figure B-5. Base Station Reception Augmented with Receive-only Sites

the associated full-function base station) and the “best quality” received signal is selected as the only received signal.

Simulcast Radio Systems

When it is necessary to provide coverage over a larger geographical area than can be covered from a single base station, simulcasting can be a more convenient way to combine the coverage area of multiple base stations, as shown in Figure B-6. Simulcast base stations use a duplex frequency plan at each site, but the same frequency pair, the same transmit frequency (solid lines), and the same receive frequency (dashed line), is used at all sites. Unlike multi-site duplex systems described earlier, simulcast systems allow a mobile user to operate with a uniform pair of transmit and receive frequencies over the entire coverage area. The three circles in Figure B-6 show nominal coverage areas for each of the three simulcast base stations.

As shown in Figure B-6, the set of simulcasting sites typically produce some overlapping coverage areas where a given receiver, e.g., M₃, could receive approximately equal usable levels of signal from more than one base station site. To prevent these multiple signals from interfering with each other, the relative frequencies and time delays of these signals must be precisely controlled. This is accomplished by synchronizing frequencies transmitted at all sites and uniformly delaying the transmission of signals at each site to compensate for the relative time delays incurred in transporting the signal to each transmitter site. In the past, it was quite difficult to synchronize the frequencies, but now it is relatively simple to use Global Positioning System signals from satellites to synchronize clocks and frequency sources at multiple sites.

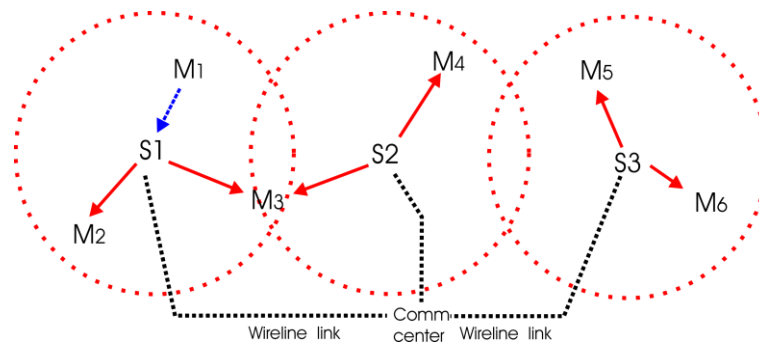

Figure B-6. Simulcast System

Simulcast systems also allow a single frequency, paired with the base transmitter frequency, to be used for mobile transmitters sending messages to the simulcast base stations. Typically, the signals received by each base station are all sent back to the simulcast communications center, where they are compared and the best signal is sent to the dispatcher, similar to multiple receive-only sites. As with other duplex radio systems, any messages received from mobile users may, or may not, be re-transmitted simultaneously to the rest of the mobile users.

Thus, simulcast systems can provide very convenient duplex radio services over a much larger multi-site coverage area, using a single pair of base station transmit and receive frequencies. The simulcast system allows a simple mobile radio to be used across the full geographical coverage area without needing to switch frequencies or make other adjustments.

Trunked Radio Systems

When there are a large number of users concentrated in a given area (i.e., urban), and frequency resources are limited, trunked radio systems are a particularly useful type of half-duplex radio system. The half-duplex system concepts demonstrated in Figure B-4 also apply to trunked radio systems. In trunked radio systems, multiple half-duplex radio channels are available, but none of them are permanently associated with a given user or function. Instead, the trunked system temporarily designates an arbitrary channel for a given user message at the instant that the user requests a radio channel. The only criterion for choosing a particular channel is that the channel is currently available (i.e., not being used by any other user) at the time when the user requests a channel.

The appeal of trunked radio systems is that each channel of a trunked radio system can carry considerably more traffic than a similar channel on a conventional radio system, with no apparent user awareness of the presence of the other users. If “User A” were sharing a channel with other users on a conventional radio system, User A would be blocked from service if any of the other users were currently talking on the shared channel. For example, if the other users kept the channel busy for 20 percent of the time, User A should expect to find the channel unavailable for use 20 percent of the time. If User A needed immediate access to a radio channel at all times, this could be accomplished only by sharing his channel with no other users (or perhaps only a very few users). However, if User A were sharing channels on a trunked radio system having ten channels, for example, where other users kept all of the channels in use for 20 percent of the time, the blocking situation is much different. Since User A can be given any one of the ten channels, User A will be blocked only if all ten channels are simultaneously in use. The probability of all ten channels being used is much smaller than the probability that a single “User A” channel is in use. Therefore, each trunked system channel can carry much more traffic on average before User A will typically have to wait until other users stop talking.

Another capability of trunked radio systems is the ability to divide users into various “talk groups.” These talk groups determine which users receive which messages. In general, each user belonging to a specific talk group hears the messages addressed to that talk group and transmits messages to the other members of that talk group. This feature allows the trunked radio system to divide its many users into various independent talk groups that match the functional groupings by which agency missions are accomplished. Additionally, existing talk groups can be rapidly modified to allow the talk group structures to adapt to new situations, such as major events or emergencies that require new cross-agency interoperability and command structures.

Trunked systems become particularly flexible and more powerful when multiple trunked sites are assembled into networks of trunked systems. Such networks are quite complex and expensive, but they can have considerable advantages over single-site trunked radio systems.

However, to provide these services, the capabilities of the individual trunked base stations must be combined into a system using inter-site connections, which are often broadband wireline or point-to-point microwave, and controlled with complex computer/controllers. For example, when a radio user within the coverage area of one site calls a talk group that is spread across the coverage areas of multiple sites, the required communications can be provided only by the unified network. Among various data that the network requires, for example, is the approximate current location of each talk group member, so that calls can be sent out via all of the required base stations. In addition, the network must know the current talk groups for each user, user radio capabilities, authorization, and encryption data. This information must be updated whenever a radio user moves from one base station coverage area to another, turns its radio off or if it moves temporarily out of range.

The ability of the intelligent network to connect the sites is important since the network intelligence is what converts individual base station capabilities to a system having statewide, nationwide, or possibly even worldwide, coverage with a wide range of techniques to adapt to highly variable communications needs. There are also issues about the reliability and robustness of the network connecting the sites as well as the ability of base stations to continue critical operations if the network connections are severed. Since all traffic has to move through the base station sites, a failure of the links connecting a site to the control network could render the system completely inoperable. In some systems, the base stations have independent local operation software that allows them to act as stand-alone trunked repeaters if the connections to the network fail. This allows a partial set of communications capabilities to continue functioning, though it could not provide capabilities that depend on interconnection to the other elements of the network.

CHANNEL PLAN

Section 4.3.9 of the NTIA Manual of Regulations and Procedures for Federal Frequency Management provides a channel plan used as a guide for identifying center frequencies for assignments in the 406.1-420 MHz band.³ The channel plan lists pairs of frequencies that are to be used for two-frequency simplex and single frequency operations.

3. National Telecommunications and Information Administration, Manual of Regulations and Procedures for Federal Radio Frequency Management, Washington, D.C., January 2008 edition, revised May 2008.

FREQUENCY ASSIGNMENT DATA

Figures B-7 through B-10 provide distributions of technical parameters for 410-420 MHz LMR frequency assignments contained in the GMF.⁴ The technical parameters include: transmitter bandwidth, transmitter power, antenna height, and antenna gain.

Figure B-7 shows the distribution of transmitter bandwidth in the 410-420 MHz band.

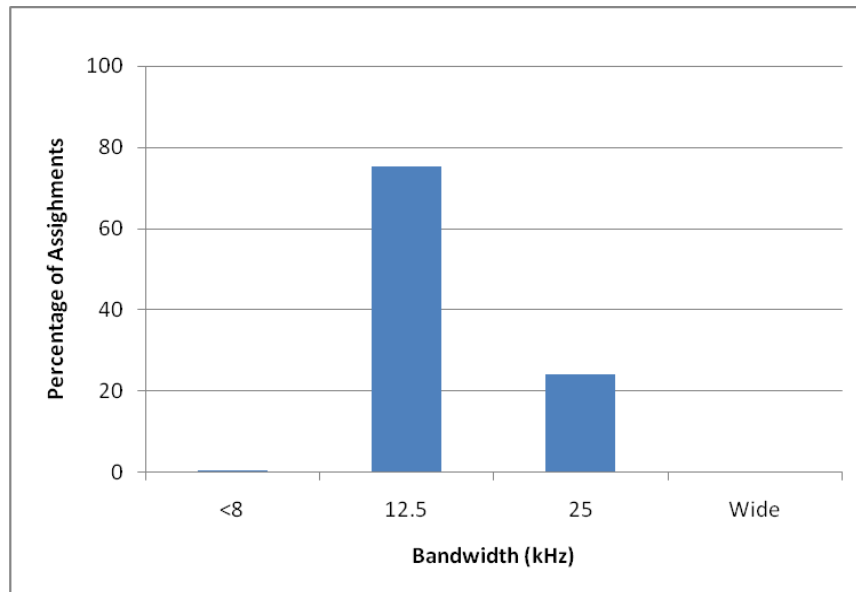

Figure B-7. Distribution of Transmitter Bandwidth in the 410-420 MHz Band

Figure B-8 shows the distribution of transmit power in the 410-420 MHz band.

4. A description of the data elements contained in the GMF is provided in Chapter 9 of the NTIA Manual of Regulations and Procedures for Federal Radio Frequency Management (January 2009 Revision of the January 2008 Edition) at <http://www.ntia.doc.gov/osmhome/redbook/redbook.html>.

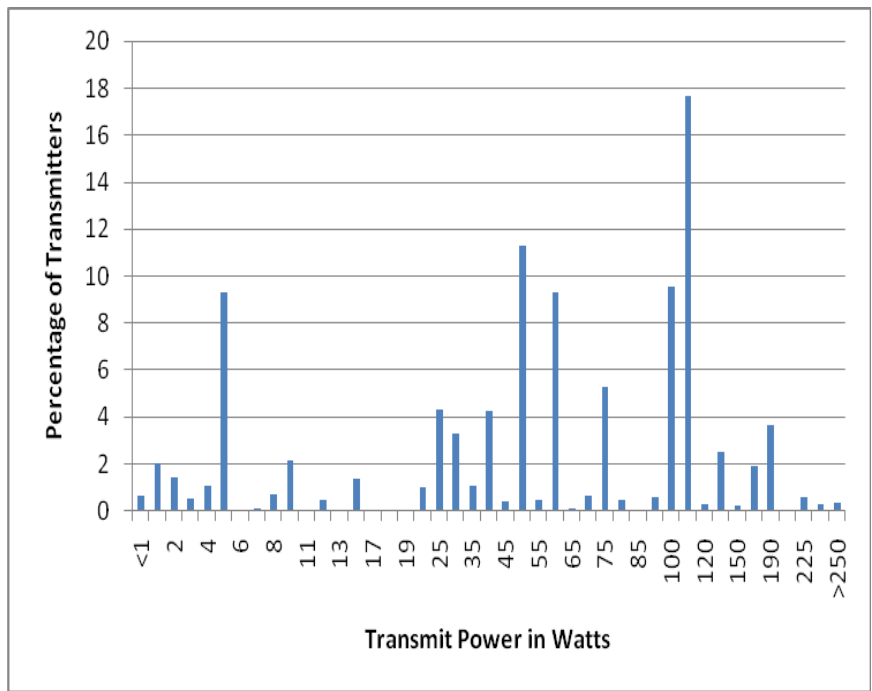

Figure B-8. Distribution of Transmit Power in the 410-420 MHz Band

Figure B-9 shows the distribution of antenna height in the 410-420 MHz band.

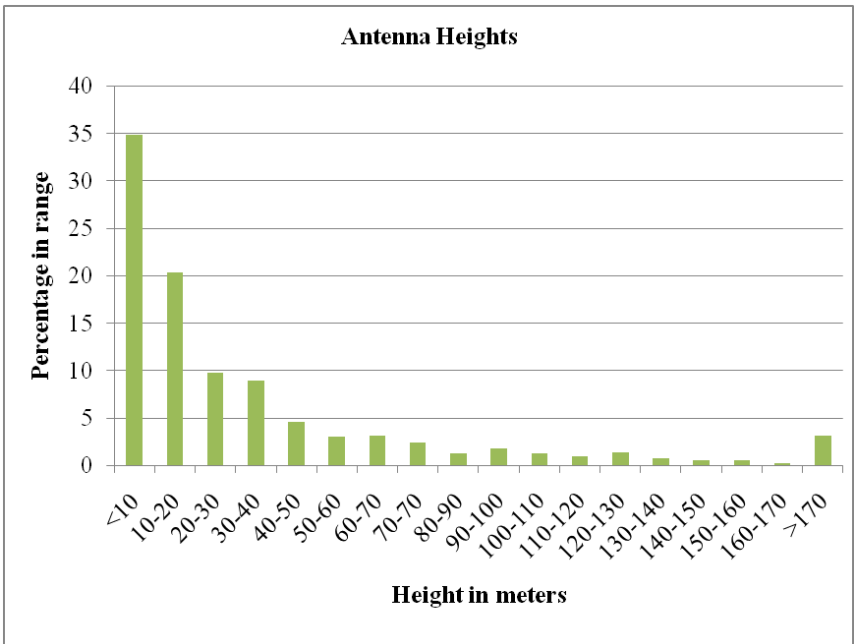

Figure B-9. Distribution of Antenna Heights in the 410 – 420 MHz Band

Figure B-10 shows the distribution of base station antenna gain in the 410-420 MHz band.

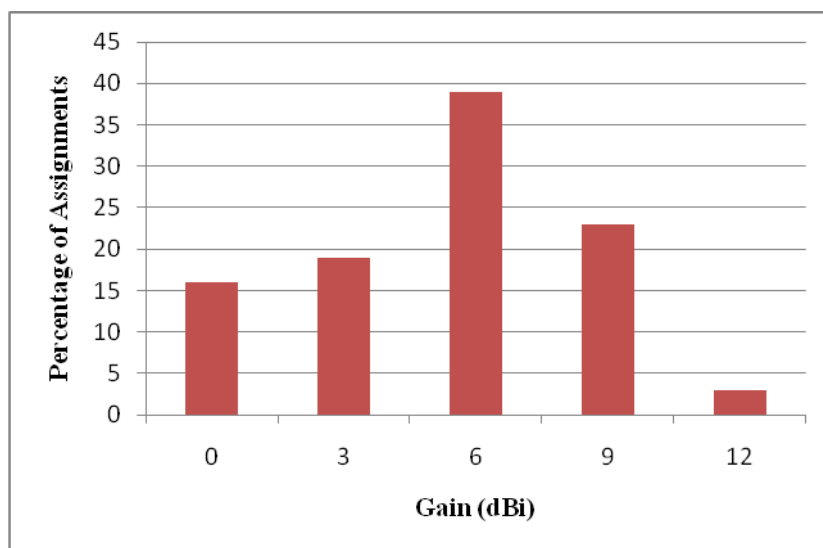

Figure B-10. Distribution of Antenna Gain in the 410-420 MHz Band

CHANNEL OCCUPANCY MEASUREMENTS

Figure B-11 provides an example of channel occupancy measurements made in the 406.1-420 MHz band by NTIA in the Washington DC area.⁵ These measurements should be considered typical of a heavily used LMR environment. The measurement results are shown for 25 kHz and 12.5 kHz channelization. The curve labeled All Channels should be considered most representative of the actual use of the band. The daily usage shown in Figure B-11 is expressed in terms of percentage of time and total Erlangs.⁶

5. National Telecommunications and Information Administration, NTIA Report TR-07-448, *Measurements to Characterize Land Mobile Channel Occupancy for Federal Bands 162-174 MHz and 406-420 MHz in the Washington, D.C., Area* (July 2007) at <http://www.its.bldrdoc.gov/pub/ntia-rpt/07-448/>.

6. An Erlang is a traffic equivalent to full time occupancy of a channel for an hour. For example, one channel used continuously for 60 minutes, or two channels with a combined usage of 60 minutes.

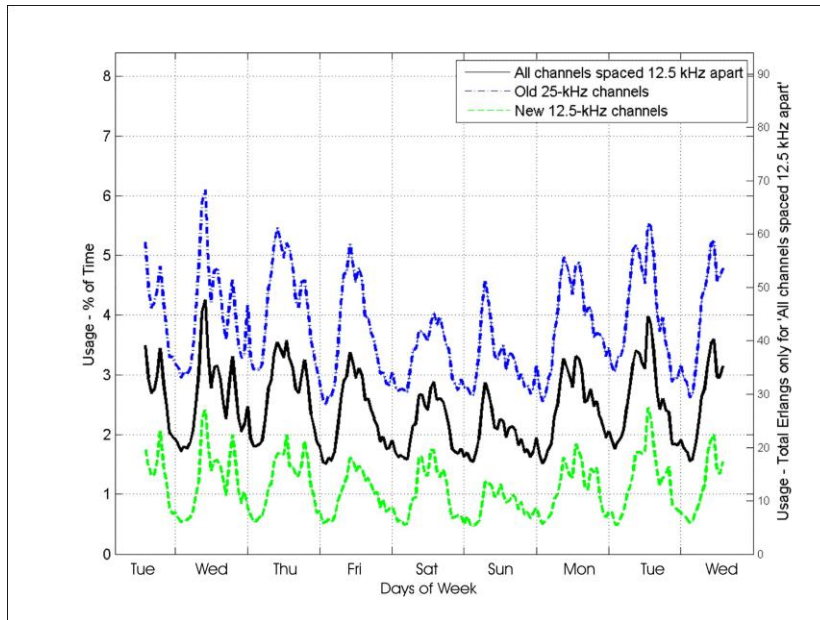

Figure B-11. Example of Daily Usage