

# CHAIRMAN OF THE JOINT CHIEFS OF STAFF INSTRUCTION

---

J-3  
DISTRIBUTION: A, B, C, JS-LAN, S

CJCSI 3401.01E  
13 April 2010

## JOINT COMBAT CAPABILITY ASSESSMENT

References: See Enclosure F.

1. Purpose. This instruction establishes the Joint Combat Capability Assessment (JCCA) as the policy and process for reporting and assessing the readiness of the Department of Defense (DOD) to execute the National Military Strategy (NMS). The JCCA is a major component of the Chairman's Readiness System.
2. Cancellation. CJCSI 3401.01D, 10 December 2004, "Chairman's Readiness System," is canceled.
3. Applicability. This instruction applies to the unified and specified combatant commands, Services, Joint Staff, and the following DOD combat support agencies (CSAs): Defense Intelligence Agency, Defense Information Systems Agency, Defense Logistics Agency (DLA), National Geospatial-Intelligence Agency, National Security Agency, Defense Threat Reduction Agency, and Defense Contract Management Agency.
4. Policy
  - a. Title 10, United States Code requires the Chairman to perform the following tasks:
    - (1) Establish, after consultation with the unified combatant commands (UCCs), a uniform system for evaluating the preparedness of each UCC to carry out assigned missions (Section 153(a)(3)(d)).

(2) Establish a uniform system for reporting on the readiness and responsiveness of the CSAs to perform with respect to a war or threat to national security (sections 193(a) and (c)).

(3) Conduct, on a quarterly basis, a joint review to measure the Department of Defense's readiness to execute the NMS (Section 117(d)(1)(a)).

(4) Submit to the Secretary of Defense the results of each review, including deficiencies in readiness identified during that review (Section 117(d)(2)).

(5) Provide for the preparation and review of contingency plans that conform to policy guidance from the President and Secretary of Defense (Section 153(a)(3)(a)).

(6) Advise the Secretary of Defense on critical deficiencies and strengths in force capabilities identified during the preparation and review of contingency plans (Section 153(a)(3)(c)).

b. The JCCA, as established in enclosures A through E, fulfills the Chairman's statutory requirements identified above.

5. Definitions. See the Glossary.

6. Responsibilities. See Enclosure B.

7. Summary of Changes. This instruction updates CJCSI 3401.01D. It further:

a. Cancels the Joint Quarterly Readiness Review (JQRR) process, which included the Feedback JQRR, the JQRR scenario, the Strategic Readiness Review, and the Semiannual Deficiency Review.

b. Replaces the JQRR with the JCCA process that arrives at an assessment of the Department of Defense's readiness to execute the NMS.

c. Replaces the JQRR scenario with periodic JCCA plans assessments led by J-7, reviewed by the Joint Combat Capabilities Assessment Group, and briefed to the Joint Chiefs of Staff.

8. Releasability. This instruction is approved for public release; distribution is unlimited. DOD components (to include the combatant commands), other federal agencies, and the public may obtain copies of this instruction through the Internet from the CJCS Directives Home Page--  
[http://www.dtic.mil/cjcs\\_directives](http://www.dtic.mil/cjcs_directives).

9. Effective Date. This instruction is effective upon receipt.

For the Chairman of the Joint Chiefs of Staff:

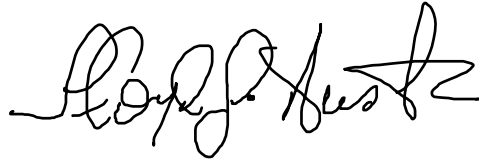
A handwritten signature in black ink, appearing to read "Lloyd J. Austin III". The signature is fluid and cursive, with a prominent loop at the end.

LLOYD J. AUSTIN III  
Lieutenant General, USA  
Director, Joint Staff

Enclosures:

- A -- Introduction
- B -- Responsibilities
- C -- JCCA Input
- D -- JCCA Output
- E -- JCCA Output Synchronization
- F -- References
- GL -- Glossary

(INTENTIONALLY BLANK)

DISTRIBUTION

Distribution A, B, C, and JS-LAN plus the following:

	Copies
Secretary of State.....	2
Director of Central Intelligence.....	2
Deputy Under Secretary of Defense for Readiness.....	3
Assistant Secretary of Defense (International Security Affairs).....	2
Director, Program Analysis and Evaluation, OSD.....	2
President, National Defense University.....	2
President, Naval War College.....	2
Commander, Air University.....	2
Commandant, U.S. Army War College.....	2
Commandant, Joint Forces Staff College.....	2
Commandant, Army Command and General Staff College.....	2
President, Marine Corps University.....	2
Director, Joint Interoperability Test Center.....	2

(INTENTIONALLY BLANK)

LIST OF EFFECTIVE PAGES

The following is a list of effective pages. Use this list to verify the currency and completeness of the document. An “O” indicates a page in the original document.

PAGE	CHANGE	PAGE	CHANGE
1 thru 4	O	F-1 thru F-2	O
i thru vi	O	GL-1 thru GL-2	O
A-1 thru A-4	O		
B-1 thru B-4	O		
C-1 thru C-6	O		
C-A-1 thru C-A-2	O		
C-B-1 thru C-B-2	O		
C-C-1 thru C-C-2	O		
D-1 thru D-4	O		
D-A-1 thru D-A-16	O		
E-1 thru E-6	O		

(INTENTIONALLY BLANK)



TABLE OF CONTENTS

ENCLOSURE	Page
A INTRODUCTION	
General .....	A-1
Changes to Policy .....	A-3
B RESPONSIBILITIES	
Unified and Specific Combatant Commands .....	B-1
Services.....	B-1
Combat Support Agencies.....	B-1
National Guard Bureau .....	B-1
Director, Joint Staff.....	B-2
Joint Combat Capabilities Assessment Group (JCCAG).....	B-2
Combatant Commands and CSAs .....	B-3
Services, USJFCOM, and JSPs .....	B-3
C JCCA INPUT	
General .....	C-1
Overall Readiness Assessment (RA).....	C-1
Top Concerns .....	C-2
JMET/AMET/JCA .....	C-2
Mission Assessments.....	C-3
Additional Mission/Plan Reporting Requirements .....	C-3
Readiness Deficiencies.....	C-5
Service and USSOCOM Reporting Requirements.....	C-6
Appendix A -- Top Concern Reporting Format.....	C-A-1
Appendix B -- MET/Mission/JCA Assessment Details Format .....	C-B-1
Appendix C -- Readiness Deficiency Format.....	C-C-1
D JCCA OUPUT	
General .....	D-1
Joint Force Readiness Review .....	D-1
Plans Assessment.....	D-2
Readiness Deficiency Assessment .....	D-2
Quarterly Readiness Report to Congress.....	D-3
Appendix -- Plans Assessments Process Details .....	D-A-1

E JCCA OUPUT SYNCHRONIZATION

General .....E-1  
Formal Linkage of JCCA Outputs .....E-2

F REFERENCES..... F-1

GLOSSARY OF ACRONYMS AND ABBREVIATIONS .....GL-1

FIGURES

A-1 Chairman’s Readiness System.....A-1  
A-2 Joint Combat Capability Assessment Model .....A-2  
D-1 Readiness Deficiency Process ..... D-3  
D-A-1 Contingency Sourcing Options ..... D-A-7  
D-A-2 Joint Staff J-5 Military Risk Matrix ..... D-A-9  
D-A-3 Joint Staff J-7 Process Outline ..... D-A-15  
D-A-4 Joint Staff J-7 Notional Process Time Line..... D-A-16  
E-1 JCCA Output Synchronization .....E-2  
E-2 Risk Framework.....E-3  
E-3 Capability Gap Assessment Process .....E-4  
E-4 JCCA Process Mitigation .....E-5

TABLES

C-1 Readiness Assessment Level Definitions .....C-1  
C-2 Three Tiered Readiness Metric.....C-2  
C-3 Deficiency Status .....C-6  
D-A-1 Plan Assessment Focus Areas ..... D-A-1

ENCLOSURE A

INTRODUCTION

1. General. The Chairman's Readiness System (CRS) establishes a common framework for assessing unit and joint readiness against approved strategic planning documents. The CRS has two main elements, unit reporting and strategic assessment (Figure A-1). Unit reporting is governed by policy set forth in the DODD 7730.65 series and amplified by the Defense Readiness Reporting System (DRRS) DODI and the Chairman's Unit Reporting Instruction. The set of unit reporting directives, instructions, and manuals provides the readiness reporting policy and procedures that support the assessments conducted under the JCCA process. The JCCA process is designed to support the Chairman in his execution of Title 10 responsibilities and to inform other Joint Staff processes that require readiness input.

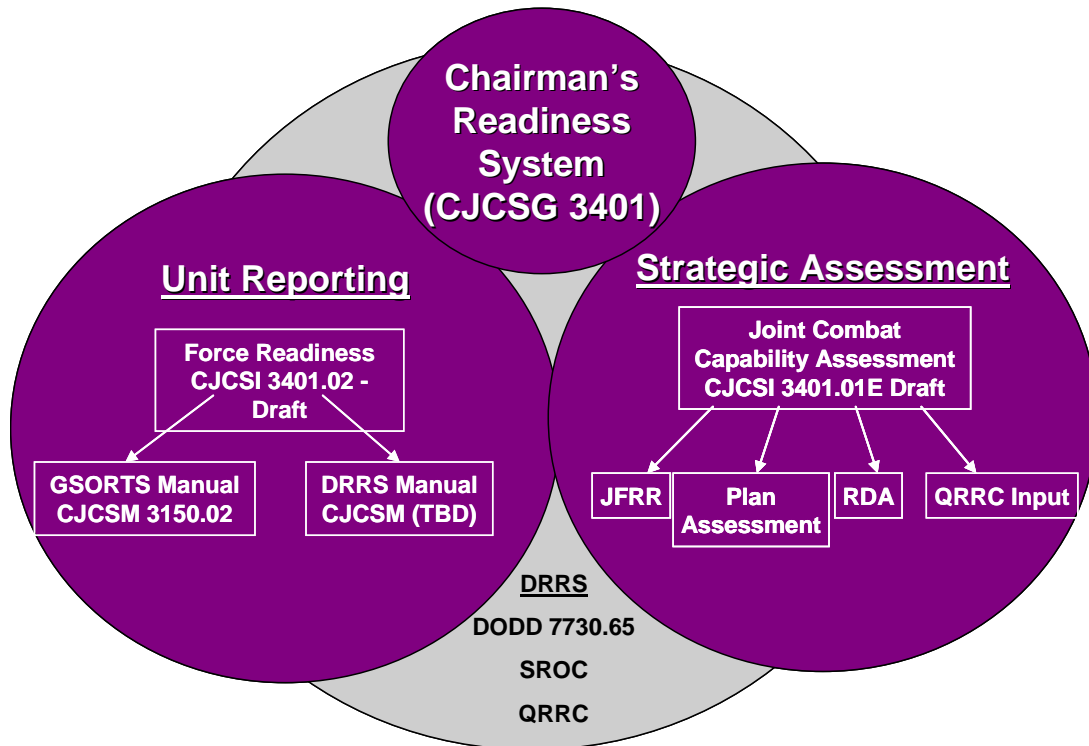

Figure A-1. Chairman's Readiness System

This instruction focuses on the framework for reporting Joint readiness -- the JCCA. As directed by the Department of Defense and Chairman:

a. Individual units report their readiness through their Services for core and directed missions. Reports are focused on status of resources such as personnel, supply, equipment, ordnance, and training. Their capabilities are focused on executing mission essential tasks (METs) in support of combatant commanders' missions. Guidance and procedures are found in the CJCSI 3401.02 series.

b. Services in their Title 10 roles report aggregated readiness against approved Joint Capability Areas (JCAs).

c. Combatant commands and CSAs report readiness to integrate and synchronize Joint forces to execute NMS missions, as derived from the Guidance for the Employment of the Force (GEF) and the Joint Strategic Capabilities Plan (JSCP).

d. The JCCA process, within the CRS, combines and analyzes these assessments to provide the Chairman with a snapshot of DOD's strategic readiness to execute the NMS (Figure A-2).



Figure A-2. Joint Combat Capability Assessment Model

e. The JCCA process delivers four products (Enclosure D) targeted to the Chairman's Title 10 responsibilities that inform leaders on the state of Joint readiness and inform other CJCS and Office of the Secretary of Defense (OSD) processes (see Enclosure E for JCCA Output Synchronization).

f. Operational shortfalls and deficiencies will be identified through the JCCA process and articulated through the products of JCCA. Resolution of these shortfalls and deficiencies will normally be addressed through and tracked by other existing management processes such as Global Force Management, Persistent Shortfalls, Joint Urgent Operational Needs Statements, or the Capability Gap Assessment (CGA) processes. JCCA products and their synchronization with these other processes are addressed in enclosures D and E.

2. Changes to Policy. All recommended changes to the JCCA or this instruction must be submitted to the Joint Staff/J-3 for coordination with the UCCs, Services, CSAs, and the Joint Staff. The Chairman must approve significant changes.

(INTENTIONALLY BLANK)

ENCLOSURE B  
RESPONSIBILITIES

1. Unified and Specific Combatant Commands

- a. Assess and report readiness against their joint mission-essential tasks (JMETs) in DRRS to the Joint Staff per Enclosure C.
- b. Provide a representative to participate in the Joint Combat Capabilities Assessment Group and in the annual Global Readiness Conference.

2. Services

- a. Assess and report readiness against JCAs (Services) and also report readiness against aggregated category-level (C-level) Services and USSOCOM data per Enclosure C.
- b. Provide a representative to participate in the Joint Combat Capabilities Assessment Group and in the annual Global Readiness Conference.

3. Combat Support Agencies

- a. Assess and report readiness against agency mission-essential tasks (AMETs) to the Joint Staff per Enclosure C.
- b. Provide a representative to participate in the Joint Combat Capabilities Assessment Group and in the annual Global Readiness Conference.

4. National Guard Bureau

- a. Assess and report readiness against its JMETs in DRRS to the Joint Staff per Enclosure C.
- b. Provide a representative to participate in the Joint Combat Capabilities Assessment Group and in the annual Global Readiness Conference.

5. Director, Joint Staff. The Director, Joint Staff (DJS) supervises the JCCA process.

6. Joint Combat Capabilities Assessment Group (JCCAG). The JCCAG will convene quarterly (at a minimum) to collaborate on JCCA assessments of the Department of Defense's ability to execute the NMS and will synchronize the delivery of those assessments to inform other Joint Staff and OSD processes.

a. J-1. Provide subject matter expertise on the impact of manpower-related issues identified in JCCA assessments on the Department of Defense's ability to execute the NMS. Maintain situational and functional awareness of all deficiencies in UCCs and CSAs. Liaison with the appropriate Functional Capability Board (FCB) owning the deficiency.

b. J-2. Provide subject matter expertise on the impact of intelligence-related issues identified in JCCA assessments on the Department of Defense's ability to execute the NMS. Maintain situational and functional awareness of all deficiencies in UCCs and CSAs. Liaison with the appropriate FCB owning the respective deficiency.

c. J-3. Serve as the JCCAG chair and secretariat. Has responsibility to:

(1) Coordinate JCCAG meetings.

(2) Conduct the Joint Force Readiness Review (JFFR) and brief the results to the JCCAG.

(3) Conduct the Readiness Deficiency Assessment and brief the results to the JCCAG.

(4) Staff JCCA outputs.

(5) Coordinate plans assessments schedule with J-7, J-33, and USJFCOM and USSOCOM staffs.

(6) Synchronize the delivery of JCCA outputs to inform other Joint Staff and OSD processes.

(7) Schedule and run the annual Readiness Conference.

d. J-4. Provide subject matter expertise on the impact of logistics-related issues identified in JCCA on the Department of Defense's ability to execute the NMS. Maintain situational and functional awareness of all deficiencies in UCCs and CSAs. Liaison with the appropriate FCB owning the deficiency.

e. J-5. Incorporate JCCA assessments in the Chairman's Risk Assessment (CRA) process, and brief the CRA to the JCCAG.



f. J-6. Provide subject matter expertise on the impact of command, control, communications, and computer-related issues (identified in JCCA assessments) on DOD's ability to execute the NMS. Maintain situational and functional awareness of all deficiencies in UCCs and CSAs. Liaison with the appropriate FCB owning the deficiency.

g. J-7. Lead plans assessments and brief results to the JCCAG. Formulate plan assessment schedule with UCCs and USJFCOM, and prepare schedule for briefing and approval at the Global Force Management Board (GFMB).

h. J-8. Incorporate JCCA assessments in the development of the Annual Report on Combat Command Requirements (ARCCR) and CGA and brief the results to the JCCAG.

i. Combatant Commands and CSAs

(1) Inform the JCCAG of issues affecting the combatant commands' ability to execute and the CSA's ability to support assigned missions from the GEF and JSCP.

(2) Participate in the plans assessments process (see Enclosure D).

j. Services, USJFCOM, and JFPs. Inform the JCCAG of issues impacting the Services'/USSOCOMs' ability to provide organized, trained, and equipped forces in support of current operations and plans.

(INTENTIONALLY BLANK)

ENCLOSURE C

JCCA INPUT

1. General. This enclosure establishes the Chairman's Readiness System reporting requirement for assessing combatant command, Service, and CSA unit (C/S/A) and joint readiness. The C/S/A readiness assessments constitute the inputs to the JCCA and will be reported as of 15 October, 15 January, 15 April, and 15 July of each year.

2. Overall Readiness Assessment (RA). Combatant commands, Services, and CSAs will assign an overall RA level to their Current and Projected Readiness Assessment. Refer to Table C-1 below for RA level definitions.

a. Projected readiness assessments predict change to readiness ratings in cases where enough information exists to do so with confidence. In cases where such a prediction is possible, the estimated time frame will be listed. In cases where there is insufficient information to make such a prediction, the reporting organization will report "No Projected Change."

b. Overall RA level is determined by commanders, Service Chiefs, and directors. When determining the overall RA level, reporting organizations should consider:

- (1) JMETL/AMETL/JCA assessment.
- (2) Results of recent plan assessments.
- (3) Readiness deficiencies.

<b>RA Level</b>	<b>Readiness Assessment Definition</b>
<b>RA-1</b>	Issues and/or shortfalls have negligible impact on readiness and ability to execute assigned mission(s) in support of the NMS as directed in the GEF and JSCP.
<b>RA-2</b>	Issues and/or shortfalls have limited impact on readiness and ability to execute assigned missions in support of the NMS as directed in the GEF and JSCP.

<b>RA-3</b>	Issues and/or shortfalls have significant impact on readiness and ability to execute assigned mission(s) in support of the NMS as directed in the GEF and JSCP.
<b>RA-4</b>	Issues and/or shortfalls preclude accomplishment of assigned mission(s) in support of the NMS as directed in the GEF and JSCP.

Table C-1. Readiness Assessment Level Definitions

3. Top Concerns. All commanders, Service Chiefs, and directors will identify their top two readiness concerns. The purpose is to inform the Chairman of their most important, near-term readiness issues. Refer to Appendix A for top two concerns information requirements and format.

4. Commanders, Service Chiefs, and Directors Narrative. The purpose of this narrative is to allow the commander, Service Chief, and CSA Director an opportunity to present any additional discussion, detail, or issues regarding their readiness reports. The format for the narrative is not prescriptive.

5. JMET/AMET/JCA

a. Commanders, Service Chiefs, and agency directors will assess the ability of their organization to accomplish a task to standard under conditions specified in their JMETL/AMETL. This assessment should be informed by observed performance, resource availability, and military judgment and will be measured against the three-tiered, Yes/Qualified Yes/No (Y/Q/N) readiness metric.

<b>Rating</b>	<b>Definition</b>
<b>Y</b>	Unit can accomplish task to established standards and conditions.
<b>Q</b>	Unit can accomplish all or most of the task to standard under most conditions. The specific standards and conditions, as well as the shortfalls or issues impacting the unit's task, must be clearly detailed in the MET assessment.
<b>N</b>	Unit unable to accomplish the task to prescribed standard and conditions at this time.

Table C-2. Three-Tiered Readiness Metric

b. Service Chiefs will assess the ability of their Service to provide organized, trained, and equipped forces capable of executing their designed tasks and

providing required capabilities to support assigned missions, reported against the JCAs at an appropriate level of aggregation (tier), and measured using the Y/Q/N metric.

c. In all cases where a JMET/AMET/JCA receives a “Q” or “N” assessment, reporting organizations must offer an explanation of the issue(s) driving the MET or JCA to a “Q” or an “N” in the text box associated with that assessment. Refer to Appendix B for J/AMET and JCA requirements and format.

6. Mission Assessments. Commanders and agency directors will assess the ability of their organization to execute assigned missions. This assessment will not only include assessments against individual J/AMETs but will also consider the mission as a whole. In addition to individual MET assessments, mission assessments will be influenced by military judgment, experience, and the political/military environment. The following guidelines will be used to ensure consistent mission assessments:

a. If the majority of the command-level METs are assessed as “Yes” and the remaining METs are assessed as “Qualified Yes,” then the overall assessment should be “Yes.”

b. If the majority of the command-level METs are assessed as “Qualified Yes” and the remaining METs are assessed as “Yes,” then the overall mission assessment should be “Qualified Yes.”

c. If any of the tasks are assessed as “No,” the commander must make a judgment as to whether the mission objectives can still be accomplished. If the commander makes a subjective upgrade for an overall mission assessment to anything other than “No,” the commander should clearly explain how the plan will be accomplished despite the inability to accomplish the MET and any mitigation actions that will be taken.

7. Additional Mission/Plan Reporting Requirements. The combatant commands and CSAs will be required, when the functionality is approved and developed in DRRS, to distinguish between types of missions/plans to help senior leaders and DRRS users easily distinguish between current operations, JSCP top priority plans, and all other plans. Within DRRS, UCCs and CSAs will also provide amplifying information for assigned missions/plans indicating the level of rigor behind the Y/Q/N mission assessments so that senior leaders can draw conclusions about the executability and acceptability of a given mission.

a. Binning. Combatant commands and CSAs will bin plans under the following three categories: Current Operations, Top Priority Plans, and Other Contingency Plans.

(1) Current Operations. Combatant commands and CSAs will bin CORE, Named Operations, Theater Campaign Plans, and Other Campaign Plans in the Current Operations tab on their readiness dashboards. The Current Operations tab will be the default page that appears when the readiness dashboard is accessed.

(2) Top Priority Plans. Combatant commands and CSAs will bin JSCP-directed Top Priority Plans in the Top Priority Plans tab on their readiness dashboards.

(3) Other Contingency Plans. Combatant commands and CSAs will bin all other contingency plans not identified as Top Priority Plans in the JSCP on the Other Contingency Plans tab on their readiness dashboards.

b. Reporting

(1) Current Operations. Combatant commands and CSAs will build METLs and provide Y/Q/N mission and J/AMET assessments against TCP/Core and Named Operations. Mission assessments against all other plans, i.e., Campaign Plans, are not required.

(2) Top Priority Plans. Combatant commands and CSAs will build J/AMETLs and provide Y/Q/N mission and J/AMET assessments against all JSCP directed Top Priority Plans.

(3) Other Contingency Plans. Combatant commands and CSAs may, but are not required to, build METLs and provide Y/Q/N mission and J/AMET assessments against JSCP plans other than Top Priority plans and non-JSCP directed contingency plans.

c. Mission/Plan Executability and Acceptability. In order to reflect the rigor underpinning assessment of a given plan, combatant commands will indicate the Level of Planning Detail, whether the plan has an IPR Status, and if the plan has been through a Plan Assessment (see Enclosure D).

(1) Level of Planning Detail (Executability). Combatant commands will indicate in the Level of Planning Detail text box underneath each plan on their readiness dashboards whether it is a Level I, II, III, or IV plan in accordance with JP 5-0. The Level of Planning detail identifies the type of sourcing and priority associated with the plan.

(2) JCCA Plans Assessment (Executability). Combatant commands will indicate in the JCCA Assessed text box underneath each plan on their readiness dashboards the date the plan was briefed to the JCS Tank as a Plan

Assessment. JCCA assessed plans are the most stressing, most likely, and highest consequence plans, which will focus on the sufficiency and/or executability of the plan. The Plan Assessment will be reviewed by the JCCAG and briefed to the JCS Tank. Depending upon the plan's level, the plan will be contingency sourced and have a TPFDD built.

(3) In Progress Review (IPR) Status (Acceptability). Combatant commands and CSAs will indicate in the IPR Status text box underneath each plan on their readiness dashboards the plan's IPR Status; i.e., A, C, F, or R. The Plans IPR process determines whether a plan is proportional and worth the cost in personnel, equipment, material, time involved, or position; is consistent with the law of war; and is militarily and politically supportable.

8. Readiness Deficiencies. A Readiness Deficiency is a shortfall of resources to meet the requirements of a reporting organization's assigned mission, plan, or other documented responsibility. Readiness Deficiencies may reflect a lack of capability or capacity. The reporting of Readiness Deficiencies is designed to highlight the operational impact of these shortfalls. As such, deficiency reporting should focus on the requirement not being met and the impact to execution of the assigned mission, plan, or other responsibility and the specific mitigation measures in place.

a. C/S/As report readiness deficiencies throughout the year as a part of the quarterly JFRRs. Deficiency reporting informs the Chairman, the Joint Chiefs of Staff, and other Joint Staff and DOD senior leaders of shortfalls impacting Department of Defense's readiness to execute the NMS. Refer to Appendix C for Readiness Deficiency requirements and format.

b. The J-3 will compile all readiness deficiencies reported over the calendar year and forward them as part of the Readiness Deficiency Assessment (see Enclosure D) to J-8 to inform the ARCCR requirements and the CGA (see Enclosure E). J-8 will provide annual feedback on the status of deficiencies in the CGA process to J-39, which will provide a summary of action taken in the CGA and ongoing actions throughout the Department of Defense to address each deficiency.

c. For ease of tracking, the status of each deficiency will be reflected according to the color code in Table C-3. Prescribed readiness deficiency information requirements and format are contained in Appendix C. Note that although it informs the CGA process, the JCCA process itself is not intended to arrive at force structure, modernization, or programmatic solutions. C/S/As should continue to leverage existing resource and force management processes identified in Enclosure A to resolve their warfighting deficiencies.

Color	Deficiency Status
Green	Fix identified; completion anticipated within 2 years.
Yellow	Fix identified; completion anticipated outside of 2 years.
Red	Fix not identified; decision made to continue mitigation or assume risk.
Blue	Modification of ends or means; DOTMLPF solution should be pursued.
Grey	Deficiency received by Joint Staff for validation against requirements.
White	Deficiency validated against requirements and passed to CGA process for consideration.

Table C-3. Deficiency Status.

9. Service and USSOCOM Reporting Requirements. Service and USSOCOM readiness assessments will include the requirements identified above, to the extent possible, and the additional requirements below reported in accordance with the CJCSI 3401.02 series.

a. Report current overall resource readiness for significant combat, combat support, and combat service support units. In addition to Service/USSOCOM overall readiness, report in categories of currently deployed, next to deploy (will deploy within the next 120 days), and non-deployed forces.

b. Report deployed and next-to-deploy forces' ability to perform core and assigned missions.

c. Report all remaining non-deployed forces' ability to perform core missions.



APPENDIX A TO ENCLOSURE C

TOP CONCERN REPORTING FORMAT

1. Purpose. To ensure consistent and quality commander/chief/director “Top Concern” input across all 20 C/S/As in order to improve joint readiness assessment. The submission should be similar to an information paper in quality and content.
2. Instructions. When providing Top Concerns information, attached files uploaded into DRRS and/or provided to the Joint Staff will adhere to the following format. Do not cut and paste an IPL or deficiency submission format as a commander’s, Service Chief’s, or director’s Top Concern.

**Top Concern #1**

1. **SUBJECT**: Title/category of reporting organization’s top concern.
2. **MAJOR POINTS**: Bulleted synopsis of the concern/problem.
3. **NARRATIVE/DISCUSSION**: Detailed discussion of the problem/concern. Include background information, causal factors, and any functional information to help better understand/provide clarity to the concern/problem.
4. **IMPACT**: Identify the critical effects the top concern has on the organization. Include affected METS/assigned Plans and Missions/JCAs. Provide any future implications.
5. **RECOMMENDATION**: Propose solution/mitigation options that would alleviate the concern/problem.
6. **CDR/CHIEF/DIRECTOR COMMENTS**: When possible, include succinct comments from the reporting organization’s commander, Service Chief, or director adding personal perspective and emphasis on the concern/problem.
7. **POC**: Name, rank, organization/OPR, telephone number, date prepared.

(INTENTIONALLY BLANK)

APPENDIX B TO ENCLOSURE C

MET/MISSION/JCA ASSESSMENT DETAILS FORMAT

1. Purpose. To ensure consistent and quality “MET/Mission Assessment Detail” input across all C/S/As in order to improve joint readiness assessment.

2. Instructions. When providing “MET/Mission Assessment Detail” for a yellow Q or red N MET/Mission assessment, the format below is prescribed within the MET/Mission Assessment Comments field.

**MET:** ST X Conduct periodic readiness assessment  
**Mission(s):** TCP, OPLAN XXXX, CONPLAN XXXX, OEF, OIF  
**Mission Assessment(s):**  
**Assessment Status:** Approved  
**Rating:** Q  
**Date Assessed:** 11-Dec-2008  
**Anticipated Assessment:** N  
**Anticipated Date:** 15-Apr-2009  
**OPR:** J2  
**POC:** Last name, first name  
**Class E-mail:** lastname@comcom.smil.mil  
**Unclass E-mail:** lastname@comcom.mil  
**Comm Phone:** xxx-xxx-xxxx  
**DSN Phone:** xxx-xxx-xxxx

MET code and title

Include all missions/plans affected by the degraded MET

Provide the overall mission/plan assessment containing the degraded MET

CCDR approval status of MET assessment

Current rating of the assessed MET

Date of current assessment

Project next change in current mission/plans assessment

Provide anticipated date of changed assessment

**MET Assessment Comments:** Only provide information for the Mission column the affected MET resides in; subsequent affected plans should have their information included in their respective Mission columns.

**Issue:** Subject/title labeling of the issue impacting the assessment of a specific MET/mission.

**Discussion:** Brief description of the issue.

**Impact:** Specific impact on MET/Mission/JCA Assessment.

**Options for mitigation/solution:** What near- and long-term efforts are being taken to mitigate the risk, and proposed solutions.

**Timeline for resolution:** Estimate of duration an issue will affect specified JMETs/JCAs/mission until resolved.

**Links:** Issue's relationship to C/S/A top concerns, deficiencies, GFM shortfalls (RFFs), and risk drivers.

APPENDIX C TO ENCLOSURE C

READINESS DEFICIENCY FORMAT

1. Purpose. To ensure consistent and quality UCC and CSA “Deficiency” input across all reporting organizations in order to improve joint readiness assessment.
2. Instructions. When providing deficiency information, attached files will adhere to the following format. Do not cut and paste a “Top Concern” format as a deficiency submission.

1. **TITLE AND REPORTING ORGANIZATION:** Subject title of the Deficiency and the Reporting UCC/CSA.
2. **CURRENT REQUIREMENT NOT BEING MET AND CORRESPONDING SOURCE DOCUMENT:** Brief description of the deficient requirement and a list of the source documents the requirement is derived from (e.g., GEF, JSCP, QDR, CONPLAN XXXX, OPLAN XXXX, TSC plan, etc.).
3. **QUANTIFIED SHORTFALL/OPERATIONAL IMPACT/JMETS IMPACTED:** Objective information quantifying the shortfall, the critical effects the deficiency has on the organization’s ability to conduct its missions, and the associated JMET/AMET affected (e.g., ST X - Conduct periodic readiness assessment).
4. **ACTIONS TAKEN/NEEDED TO FIX DEFICIENCY:** Actions taken to date and proposed actions needed to fix current deficiency.
5. **RISK AND PLANNED/POTENTIAL MITIGATION ACTION:** Assess current risk deficiency contributes to execution and the planned/potential mitigation steps necessary to manage this risk.
6. **POC INFORMATION:** Name, rank, and organization.

(INTENTIONALLY BLANK)

ENCLOSURE D

JCCA OUTPUT

1. General. The JCCA evaluates the Department of Defense's readiness to execute the NMS through four assessments. The four assessments, described below, constitute the JCCA outputs and help the Chairman fulfill his Title 10 statutory requirements and inform other Joint Staff and OSD processes.

a. Joint Force Readiness Review

(1) The Joint Force Readiness Review (JFRR) is the principal assessment of the CRS. It combines and analyzes unit and joint C/S/A readiness assessments, pulled from DRRS and GSORTS, to capture the Department of Defense's strategic readiness to execute the NMS. The JFRR assists the Chairman in providing the best military advice to the President and Secretary of Defense by informing the Chairman's Risk Assessment, ARCCR, CGA, and Quarterly Readiness Report to Congress. The JFRR addresses three primary topics, which may be supplemented by additional data and analysis as best supports the Chairman and senior leadership:

(a) Overall Department Readiness Assessment. The Department's overall ability to execute the NMS.

(b) C/S/A Readiness Data. Resource and capability readiness assessments against J/AMETs/JCAs and assigned missions.

(c) Readiness Metrics and Analysis. Service and USSOCOM oriented Health of the Force metrics, force availability for contingency operations (above the line forces), and estimates of force shortfalls against key contingency operations.

(2) The JFRR will be submitted to the DJS quarterly via Joint Staff Action Processing; provided to CRA, QRRC, ARCCR, and CGA process leaders; and posted in DRRS and on designated SIPRNET Web sites after approval.

(3) The JFRR will be briefed to the Senior Readiness Oversight Council (SROC). The SROC is the Department's senior readiness forum as described in DODD 5159.02.

13 April 2010

b. Plan Assessments. Plan Assessments gauge the combatant command's ability to successfully execute key contingency plans. Force sourcing for plans will be conducted and evaluated by the Joint Force Providers and their Service components. Specific combatant command plans will be chosen to highlight operations most stressing to ground, maritime, air, and special operations forces, as well as those plans that are highest visibility, most likely, or have the most severe consequences. These assessments are expected to be conducted with a level of fidelity and timeliness that allow flexibility to react to an emerging and changing security environment without significant negative impact on the sourcing throughput of the Joint Force Providers (JFPs). Therefore, the Plan Assessments schedule will be proposed by the JCCAG and approved by the GFMB. Output of Plans Assessments will be an assessment of the overall executability of the plan supported by an analysis of the impact of sourcing and logistics shortfalls and readiness deficiencies on military risk. Plan Assessment process details are included in Appendix A of Enclosure D.

c. Readiness Deficiency Assessment. The Readiness Deficiency Assessment assesses the cumulative impact of combatant command, Service, and CSA reported deficiencies on the Department of Defense's readiness to execute the NMS. Annually, the J-3 will collect readiness deficiencies reported over a fiscal year and identify readiness trends and highlight critical deficiencies, assessed against the priorities for resources and forces outlined in the GEF. The JCCAG will review the results of the Readiness Deficiency Assessment, and the DJS will approve the assessment for release to inform J-8's ARCCR and CGA (Figure D-1).



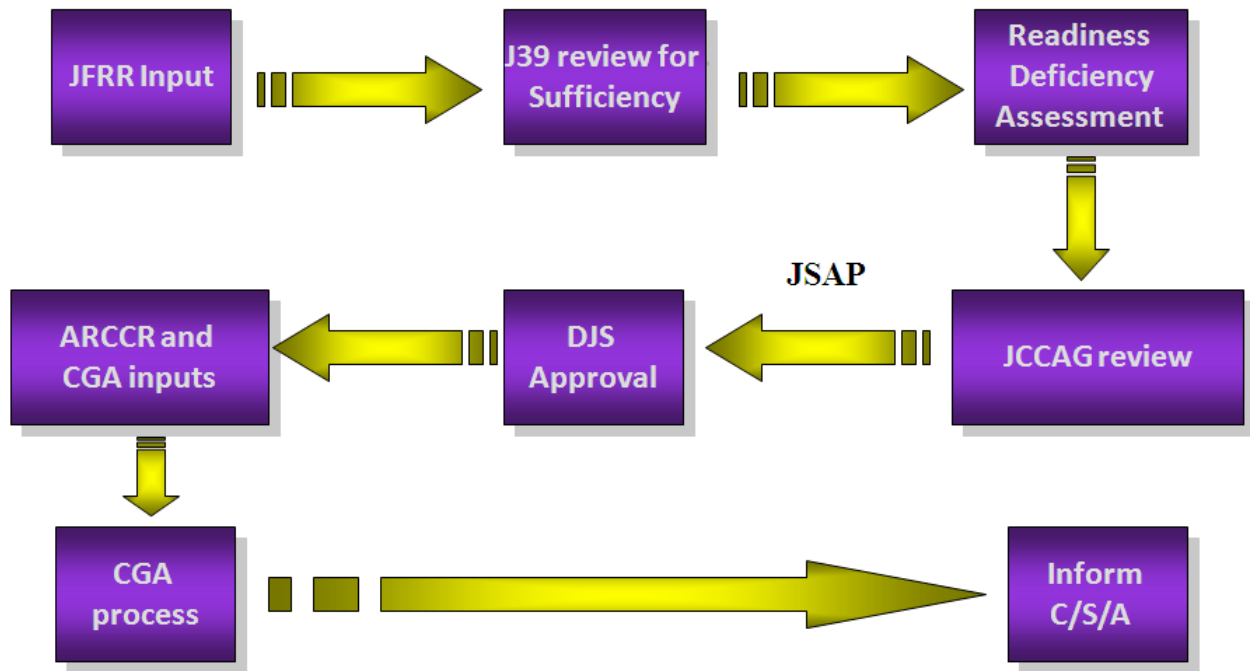

Figure D-1. Readiness Deficiency Process

d. Quarterly Readiness Report to Congress. In conjunction with the completion of the JFRR input in DRRS, J-39 Readiness will provide a text summary of the JFRR to OSD as required for inclusion in the Quarterly Readiness Report to Congress. The summary will include an overall readiness assessment (RA level) of the Department of Defense's ability to execute the NMS.

(INTENTIONALLY BLANK)

APPENDIX A TO ENCLOSURE D

PLANS ASSESSMENT PROCESS DETAILS

1. Purpose. The Joint Combat Capability Assessment (JCCA) Plan Assessment process provides an assessment of the Department’s ability to execute strategically important contingency plans. It fulfills statutory requirements for providing for the preparation and review of contingency plans that conform to policy guidance from the President and the Secretary of Defense. Assessments will be provided to the JCS Tank members and inform the Chairman’s Annual Risk Assessment.

2. Plan Assessment. The goal of the assessment is to provide timely situational awareness of the operational and strategic risks of operations plan execution to the Joint Chiefs of Staff in a common framework. The assessments will focus on the sufficiency and/or executability of JSCP tasked plans. The assessments may include, but are not limited to, the focus areas outlined in Table D-A-1. Force sourcing for the plan will be conducted and evaluated by the Joint Force Provider (JFP) and its Service components. Plan Assessments (three to five per year) should primarily focus Contingency Sourcing Option B with the supported combatant commander providing valid Time Phased Force Deployment Data TPFDD (plan assumptions and defined time line). When possible, the supported combatant commander should provide all force providers a detailed TPFDD list for contingency sourcing not later than 30 days prior to the Plan Assessment start date.

<ul style="list-style-type: none"> <li>• Roles / Responsibilities               <ul style="list-style-type: none"> <li>–Authorities</li> <li>–Supported vs. Supporting</li> <li>–DOD Lead</li> <li>–International Players</li> </ul> </li> <li>• Strategic Guidance               <ul style="list-style-type: none"> <li>–Assumptions</li> <li>–End States</li> <li>–Branches / Sequels</li> <li>–U.S.</li> <li>–International</li> </ul> </li> <li>• Intelligence and Communications</li> </ul>	<ul style="list-style-type: none"> <li>• Information Operations               <ul style="list-style-type: none"> <li>–Themes / Messages</li> </ul> </li> <li>• Whole of Government               <ul style="list-style-type: none"> <li>–Synched with supporting other USG efforts</li> <li>–Role of Dept / Agencies across plan phases</li> <li>–What “tools” do they offer</li> </ul> </li> <li>• Gaps/Seams               <ul style="list-style-type: none"> <li>–COCOMs</li> <li>–Federal Agencies</li> </ul> </li> <li>• Kinetic vs. Non-Kinetic</li> <li>• Battle Rhythm</li> </ul>	<ul style="list-style-type: none"> <li>• Contingency Sourcing</li> <li>• Force Flow</li> <li>•Transportation Assessment</li> <li>• Sustainment</li> <li>• IPL / Capability Gaps</li> <li>• Critical Enablers               <ul style="list-style-type: none"> <li>–Swing Forces</li> <li>–Strategic Lift</li> </ul> </li> <li>• Risk Mitigation</li> <li>• Timelines</li> <li>• Operational Contracting Support</li> </ul>
--	---	--

Table D-A-1. Plan Assessment Focus Areas

a. Enclosure C of the JSCP identifies three types of force and capability sourcing; only contingency sourcing is used within the JCCA Plans Assessment structure. The three types of force sourcing are contingency sourcing, execution sourcing, and preferred force sourcing. In some cases, combatant commands may use their execution sourcing data (EXORD forces) in TPFDD development. (USNORTHCOM frequently uses EXORD force data (execution sourced) in TPFDD development.) The JSCP describes each type of sourcing as follows:

(1) Contingency Sourced Forces. Specific forces identified by actual unit name and unit identification code (UIC) by the JFPs, assisted by their Service components and parent Services, meeting the planning requirement at a specified point in time. The Joint Staff provides specific guidance through a list of sourcing assumptions and planning factors contained in the contingency sourcing message or memorandum and other business rules agreed upon by the Joint Staff, the JFPs, supported combatant commanders, and the Services. The JFPs have final approval of the total sourcing solution and provide the approved solution back to the supported combatant commander in the combatant commander's requested format.

(2) Execution Sourced Forces. Specific forces recommended and identified by JFPs, assisted by their Service components (who are responsible to coordinate with their Services, as required). The recommended sourcing solution is reviewed through the GFM allocation process. The Joint Staff provides specific guidance for the selection of forces in the execution sourcing message, including unit reporting requirements that will be done in accordance with current JOPES procedures. Execution sourcing of forces may result in a Prepare to Deploy Order (PTDO), Deployment Order (DEPOD), or Execution Order (EXORD).

(3) Preferred Forces. Specific forces assigned/allocated that are identified by the supported combatant commander in order to continue employment, sustainment, and transportation planning and assess risk. These forces are planning assumptions only, are not considered "sourced" units, and do not indicate that these forces will be execution sourced.

b. Contingency Sourcing Options of Plan Assessments. There are two options for plan assessments conducted as part of the JCCA process. Option A and B assessments constitute a range of options that provide the supported commander various levels of fidelity. "Contingency sourcing" entails identifying forces for plans on a specific date and represents a snapshot depiction for senior leadership. The chart in figure D-A-1 displays additional levels of detail for A and B level contingency sourcing options.

(1) Contingency Sourcing Option A. This option for contingency sourcing includes above the line unit availability and readiness. Above the line units include major combat power units (AEW, BCT, BN, CSG, ESG, etc.) apportioned for planning in the Global Force Management Implementation Guidance. Option A sourcing will reflect substitutions of Above the Line Forces; Assessment of Critical Support Forces; Impact on high-demand, low-supply assets; a Transportation Assessment; and Reserve Component implications. If a new automated method or Adaptive Planning tool is not available to support the assessments, then a JOPES TPFDD is required.

(2) Contingency Sourcing Option B. This option for contingency sourcing results in a fully sourced level 4 Type TFPDD containing Type Unit Characteristics (TUCHA) data. It includes substitutions and mitigation factors and includes a full Transportation Assessment. Option B sourcing is a prelude to execution-level sourcing but does not typically result in notification of units or placement of units in a PTDO status. The sourcing solution from a level 2 sourcing effort usually provides a high enough level of fidelity to allow USTRANSCOM to conduct a Transportation Assessment.

c. Some JCCA events involve two or more specific scenarios or vignettes that may or may not be interlinked. Plan assessments involving multiple vignettes will be executed at the same level of detail and sourcing effort whenever possible.

3. Assessment Requirements. For a plan to be assessed, it must be strategically important and sufficiently detailed to make an assessment possible.

a. Strategic Importance. Plan selection criteria are set by the Chairman of the Joint Chiefs of Staff. The criteria that follow are generic rather than plan specific in order to allow current planning and strategic importance to dictate selection of individual plans for assessment. Plan selection is based on at least one of the following:

(1) Most stressing plans for each operational capability: ground, air, maritime, Special Operations.

(2) High visibility plans: Examples include homeland defense and consequence management.

(3) Plans with a high probability of execution.

(4) Plans that have the most severe consequences.

(5) Chairman's request for a specific top-priority plan.

b. Minimum Planning Detail

(1) In accordance with CJCSI 3141, a JSCP tasked plan must have completed an In Progress Review (IPR) 'C,' Concept Development.

(2) The JSCP tasked plan is at least Planning Detail Level I (Commander's Estimate). A standing EXORD is not sufficient to determine the executability of a plan. If there is a standing EXORD, and the required end state is to determine executability, the supported commander must develop a JOPES TPFDD for the JFPs to source. A plan without a standing JOPES TPFDD may be assessed using a scenario-developed JOPES TPFDD. Every effort will be made to align scenario-driven planning with exercises or other planning activity. (See 6.a. below.)

4. Plan Assessment Scheduling. The schedule is nominally limited by JFP contingency sourcing capability of three to five plan assessments annually. Assessment scheduling involves the following considerations.

a. A plan assessment is scheduled every quarter. The associated JCS Tank brief includes JFRR data and the plan assessment.

b. An individual plan is not normally scheduled more than annually.

c. Plan assessments are sequenced such that an individual supported commander is not completing consecutive assessments.

d. Where possible, plan assessments should follow the IPR in order to capture recent changes to the war plan.

e. Where possible, plan assessments are aligned with Chairman-level exercises (i.e., Positive Force or Positive Response), Adaptive Planning/Force Flow Conferences, or seasonal EXORD development in order to capitalize on existing work to produce a more robust assessment.

f. Contingency Sourcing Option B for assessments is limited to once a quarter unless the sourcing directly uses an active EXORD.

g. Where possible, assessments that are highly demanding of the single Service will be scheduled every other quarter. The goal is to distribute similar operational capability assessments (for example, ground intensive plans) within the annual assessment cycle to enable a balanced periodic refresh of the specific operational capability.

5. Plan Assessment Detail. Scope and detail is a balance between quantity and quality. The goal is to conduct a plan assessment in conjunction with a contingency sourced Adaptive Planning/Force Flow Conference. However, there are two significant plan assessment process variations:

a. Stand-Alone Plan Assessment. This is an operational and strategic level assessment for senior leadership.

(1) Assessment can be completed in 60 days with direct support from the combatant commands. The assessment may be completed more quickly if no forces are identified and only sufficiency issues are assessed (see Table 1).

(2) Supported combatant commander (i.e., plan owner) identifies in either a generic force list or Joint Operations Planning and Execution System (JOPES) Time Phased Force Deployment Data (TPFDD) the plan's force or capability requirements. Each force or capability requirement will be accompanied by the following: RLN; Description; UnitName; UTC; UIC; Origin; RLD; POEModeSource; POE; ALD; PODModeSource; POD; EAD; LAD; DestModeSource; Destination; and RDD.

(3) JFPs will contingency source the force and capability requirements identified by the supported combatant commander and complete a force sourcing risk assessment of the required forces and capabilities. Specifically, all "above the line" combat forces (ships, squadrons, BCTs, etc.) and critical combat support forces necessary for successful plan execution are sourced using all available forces. Although the sourcing of units with a readiness rating of C3/4 or worse is generally discouraged, it is allowed to support a combatant commander's efforts to refine a plan or assess its execution risk. The JFP can mitigate a force or capability shortfall by recommending to the supported combatant commander a unit with a readiness of C3/4 or worse if that unit is C2 or better for the specific mission, or can quickly be modified to be C2 or better prior to RLD (i.e., Navy ship C4 for ammunition that will onload prior to deployment). The supported commander has the option of either accepting or rejecting the unit. Regarding port operations capabilities sourced through USJFCOM, the supported commander, in consultation with USTRANSCOM, has the option of either accepting or rejecting the unit. It is understood that the rejection of a substitution unit will result in a force or capability shortfall. The goal is for readiness data to be less than 30 days old when briefed at the JCS Tank, but it is understood that data may be as great as 90 days old due to competing priorities. This is considered "B" level contingency sourcing (see Figure D-A-1).

(4) Transportation assessment may be conducted if the supported combatant commander has identified ports of embarkation (POEs) and ports of debarkation (PODs) within TPFDD. To the greatest extent possible, USTRANSCOM will coordinate with components and utilize actual transportation assets' availability to support the assessment.

(5) The accuracy of Contingency Sourcing Option A sourcing effort is approximately 70 percent. This is based on the complete assessment and JFP contingency sourcing of major combat units ("above the line forces") and key "below the line" elements of major combat forces. To the greatest extent possible, USTRANSCOM will coordinate with components and utilize actual transportation assets' availability to support the assessment. Note: The accuracy and analysis of sourcing and transportation data will degrade as the time line advances

b. Plan assessment occurs in conjunction with contingency sourced Adaptive Planning/Force Flow Conference. The conference and assessment provide combatant commander planners and senior leadership with valuable data at the tactical, operational, and strategic levels. Depending on the size and complexity of the contingency plan, a conference and assessment can require 3 to 4 months to complete. Significant effort by supported and supporting combatant commanders and CSAs is necessary to execute the adaptive planning conference and complete the assessment.

(1) In support of an assessment, the supported combatant commander is expected to create a TPFDD in JOPES ADP. The TPFDD should not identify all the forces required. Instead, it should identify the unit type and/or UTC capabilities that are required by the supported combatant commander to successfully execute the plan being assessed. Each UTC will be accompanied by either a CRD or LAD, as well as a POD or destination. The supported combatant commander must review and verify that the TPFDD in JOPES is ready for contingency sourcing prior to releasing it to JFPs for contingency sourcing. Once released to the JFPs, the supported combatant commander will not make any changes to the TPFDD without the JFP's and Joint Staff, J-7's approval.

(2) JFPs will contingency source the force or capability requirements identified in JOPES ADP. The goal is 100 percent sourcing. JFPs will identify each force or capability by Unit Identification Code (UIC) via UTC. Each UIC will be accompanied by level 4 TUCHA data. Typically, only C-3 and above units are sourced (C2 and above for USMC), unless both the JFP and the supported commander agree to utilize a C-4 unit. Although the sourcing of units with a readiness rating of C4 or worse is discouraged; to support a combatant commander's efforts to either refine a plan or assess its execution risk the JFP can mitigate a force or capability shortfall by recommending a unit



with a readiness of C4 to the supported combatant commander. The latter has the option of either accepting or rejecting the substitution or in lieu of unit. It is understood that the rejection of a substitution or in lieu of unit will result in a force or capability shortfall. Readiness data is typically 45-90 days old when briefed at the JCS Tank. This is a Contingency Sourcing Option “B” sourcing effort (see Figure D-A-1).

(3) Accuracy of Contingency Sourcing Option B sourcing effort is approximately 90 percent. This is based on the complete assessment and JFP contingency sourcing of completed Level 4 TPFDD (short tons, metric tons, PAX, valid assumptions, defined movement data, C/N-Days, geographical location codes, and mode/source codes) including substitutions and mitigation factors. To the greatest extent possible, USTRANSCOM will coordinate with components and utilize actual transportation assets’ availability to support the assessment. Note: The accuracy and analysis of sourcing and transportation data will degrade as the time line advances.



## Contingency Sourcing Options

	<b>A</b>	<b>B</b>
<b>Output Product</b>	<b>Above the Line Availability and Readiness</b> (BCT, EN, CSG, ESG, etc); Readiness assessment of Above the Line Units Impact on LD/HD assets; Reserve Component implications	<b>Option A with Substitutions +</b> Will reflect <u>substitutions</u> of Above the Line Forces; <u>Assessment of Critical Support Forces</u> ; Impact on LD/HD assets; Rough Trans Assessment; RC implications
<b>Min Required Input (from Supported COCOM)</b>	Level 2 plan w/ Force List Updated Assumptions Defined C-day (window)	Level 2 plan w/ Force List Updated Assumptions Defined C-day (window) Subs/Mitigation options. A valid JOFES TPFDD sourced to level 4 data detail (plan assumptions and defined timeline).*
<b>Participants</b>	JFPs & Service Components	Supported COCOM JFPs & Service Components

\* To the greatest extent possible, USTRANSCOM will coordinate with components and utilize real world transportation assets availability data (aircraft, sealift, and port operations enablers).

Figure D-A-1. Contingency Sourcing Options

6. JCCA Plan Assessment Brief Components. All descriptions are focused on producing the Plan Assessment brief. Products are generally PowerPoint slides and briefing materials necessary to field anticipated questions.

a. Assessment Scenario. Contingency plans written for a clearly defined adversary or goal may not require a specific scenario for effective plan assessment. However, some level 3/4 contingency plans with JSCP directed TPFDD must be effective against a range of threats, events, geographic locations, and conditions. An assessment of these plans requires development of a scenario or scenarios. The intent of the scenarios is not to provide a detailed sequence of events but to allow the commander to develop a tailored, specific, TPFDD or force list (to facilitate an accurate assessment dependent upon minimal ambiguous conditions and planning assumptions).

b. Intelligence/Probability Assessment. Joint Staff J-2 and the supported commander J-2 collaborate to produce a short assessment of the likelihood of plan execution in the next 12 months using the following risk scale. The scale is 0-100 percent with 10 percent increments converted to a low (0-30 percent), medium (40-60 percent), or high (70-100 percent) assessment. When possible, a trend (decreasing, no change, or increasing) will be indicated.

(1) Plan Written to Counter a Specific Threat or Adversary. Reasonable trigger events leading to plan execution should be evaluated. Each trigger event is given an execution probability assessment. When possible, recent events linked to specific trigger events are highlighted.

(2) Plan Written to Counter a Range of Threats/Events. In this case, probability assessment is challenging. For example, assessing the probability of executing a consequence management plan in response to a natural disaster is difficult at best. When possible, probability assessment should be based on historical averages.

c. Joint Targeting. Joint Staff J-2 and the supported commander, J-2, will collaborate to produce a review of combatant command targeting-related METLs associated with the CONPLAN/OPLAN. Any concerns with specific target line number status will be noted in the concerns.

d. Joint Force Provider (JFP) Information. JFP information consists of three parts: a JFP overall risk assessment, a JFP “services” risk assessment, and the JFP sourcing solution to execute the contingency plan. Each JFP assessment uses the Joint Staff J-5 Military Risk Assessment Matrix (Figure 2).



*Military Risk Matrix*

	<b>Low</b>	<b>Moderate</b>	<b>Significant</b>	<b>High</b>
<u>Strategic Objectives</u>	Strategic objective: Assured	Strategic objective: Very likely	Strategic objective: Likely	Strategic objective: Requires extraordinary measures
<u>Authorities</u>	Full authorities provided to achieve all strategic objectives	Authorities provided to achieve most strategic objectives	Authorities are insufficient to achieve key strategic objectives	Critical authorities are not provided; ability to achieve strategic objectives is compromised
<u>Plans</u>	GEF/JSCP direct advanced planning: OPLANS (Level IV) or CONPLANS (Level III)	GEF/JSCP direct preliminary planning: Base Plans (Level II) or CDR's Estimate (Level I)	GEF/JSCP do not direct planning but local plans exist or are being developed	GEF/JSCP do not direct plans and planning is not in progress
<u>Resources</u>	As planned	Additional resources from other plans and operations	Additional resources from other plans & operations; some significant capability shortfalls	Significant resources from other operations; some resources severely deficient or absent altogether
<u>Resources: Timelines</u>	As planned	Extended	Significant adjustments	Significant adjustments; may not achieve desired end-states
<u>Resources: Unanticipated Requirements</u>	Easily managed, minimal impact	May necessitate adjustments to plans	Will necessitate significant adjustments to plans	Unable to manage
<u>Resources: Force Provider</u>	Full capacity to source COCOM rqmts	Can source all rqmts. Worldwide force allocation solutions may result in limited duration capability gaps	Can source priority COCOM rqmts. Worldwide force allocation solutions may result in extended duration capability gaps	Require full mobilization to sustain sourcing solutions to achieve strategic objectives
<u>Resources: Services Functions, Force Management, Institutional Capacity</u>	Full capacity to source COCOM rqmts	Requires intra-Service adjustments to source COCOM rqmts	Requires joint source solutions and force substitutions to source COCOM rqmts	COCOM rqmts exceed Joint Force capacity to substitute capabilities

Figure D-A-2. Joint Staff J-5 Military Risk Matrix

(1) JFP Overall Risk Assessment. As applicable, USJFCOM, USSOCOM, and USTRANSCOM will each provide a risk assessment related to their ability as a JFP to support execution of the contingency plan. This assessment is independent of individual service sourcing challenges.

(2) JFP "Services" Risk Assessment. As applicable, USJFCOM, USSOCOM, and USTRANSCOM will each provide a Service-specific risk assessment prepared by each of the Service components relating to the latter's ability to support execution of the contingency plan being assessed. The JFPs will provide the Joint Staff with these Service-specific assessments as well as a single consolidated or joint assessment of the risk of sourcing the desired forces and capabilities.

(3) JFP Sourcing Solution. The primary brief includes a broad summary of forces provided and associated readiness. Availability and readiness of specific forces that could be assigned immediately if the contingency were to transition to execution is detailed in backup slides. Each JFP Service component provides detailed unit information including Commanders Required Date (CRD); Latest Arrival Date (LAD); overall readiness; the standard Personnel, Supply, Equipment Readiness, and Training (PSRT) readiness

breakdown; and any specific notes explaining additional issues. While the detailed readiness slides are not normally shown as part of the JCS Tank briefing, the information is available for Chairman and Service Chief review. More important, it is data the supported combatant commander uses as part of the basis for the execution risk assessment.

(a) Standalone Plan Assessment JFP Sourcing Solution. JFPs conduct a force availability assessment using Joint Staff sourcing assumptions of the supported commander above the line force list (with key below the line elements of combat power). All units are sourced, regardless of readiness.

(b) Plan Assessments Using Adaptive Planning Conference Data. JFPs completely contingency source the supported commander force list to develop a TPFDD. Typically, only C-3 and above units are sourced (C2 and above for USMC) unless both the JFP and the supported commander agree to utilize a C-4 unit. However, to mitigate the shortfall, the supporting command can propose sourcing a unit with a readiness of C-4, which will require acceptance approval by the supported command. Shortfall mitigation through “in lieu of” sourcing and contact with individual units to assess capability and readiness to complete specific plan requirements is not completed (completed during execution sourcing).

(4) Joint Staff J-3 will provide current JFFR data to support Service readiness data.

e. Transportation Assessment

(1) All standalone plans will undergo a logistics supportability analysis (LSA) of logistics JCAs. For plans lacking a detailed LSA, the combatant commander will identify specific logistics capability area limitations or constraints for review. USTRANSCOM completes a plan transportation assessment based on previous Adaptive Planning/Force Flow Conferences for the plan or similar sized plans and validation of available lift. Transportation assessment will consider the impact of logistics sustainment. If a plan lacks sufficient detail for a JFAST assessment, USTRANSCOM will identify potential deployment and distribution challenges (ramp space, gas, and other impediments to force flow time lines).

(2) Joint Staff J-4 will review all plans for LSA completeness.

f. Supported Commander Assessment

(1) Military Risk Drivers. Supported combatant commander identifies critical risks that drive the overall operations plan risk assessment. Issues should cover all aspects of plan execution; examples include policy, force

availability and readiness, enemy capability, and logistics. These critical risks are the foundation of the Chairman's best military advice to the President on plan executability.

(2) Overall Military Assessment. Supported combatant commander assessment of achievability of military plan objectives and an overall assessment of executability and associated risk.

(3) Mitigation Actions Underway, Proposed, and Recommended. Supported combatant commander's bulleted list of mitigation actions.

g. Trend From Previous Assessments. If applicable, a side-by-side comparison of the current and previous assessments.

h. Overall Military and Overall Strategic Risk. Joint Staff J-5 conducts a review of combatant commander assessment within the context of the overall military and overall strategic risk to the National Security Strategy, National Defense Strategy, National Military Strategies, and other governing strategic documents. Combatant commands will provide metrics for any "significant adjustments to CONPLAN time lines" in order to support noted military risks in the CRA.

i. Issues. Most issues are derived from the risk drivers or mitigation actions. Where possible, specific issues are addressed on an individual slide highlighting a solution that may include Joint Staff action, a briefing to the JCS Tank, or a specific strategic decision anticipated to be necessary during early execution of the contingency plan. Joint Staff J-8 will review all issues against current IPL submissions and the CGA.

7. JCCA Plan Assessment Production Process. The process described below is for a standalone plan assessment. Differences unique to adaptive planning conference-based plan assessments will be highlighted. Short time lines for each segment are necessary to produce a product quickly with limited degradation of force availability and readiness data. Additionally, the short time lines enable the process to respond effectively to a no-notice Chairman's request. As OPR and principal briefer of the plan assessment, Joint Staff J-7 coordinates all combatant commander, Service, and Joint Staff involvement in the assessment through frequent video teleconferences, e-mails, and telephone conversations.

a. JCCA Plan Assessment Execution Message. This message provides plan assessment tasking to all supported and supporting commanders. The message includes sourcing assumptions, planning guidance, and the time line for task completion. The message is normally drafted 2 months prior to the assessment. Sourcing assumptions and planning guidance for adaptive

planning conference-based plan assessments are provided in the contingency sourcing order and are referenced in the plan assessment execution message.

b. Plan Assessment Scenario. When required, Joint Staff, the supported commander, and USTRANSCOM collaborate to prepare a brief scenario to drive the commander to create or select a specific force list to facilitate assessment.

c. Supported Commander Force List. The supported commander provides a list of forces including all “above the line” combat forces and key “below the line” elements of combat power to the JFPs approximately 35 days in advance of the JCS Tank brief. The list of forces should not exceed 400 total individual unit requests. JCCAG will adjudicate any force list issues. The complete force list is contingency sourced for each adaptive planning conference-based plan assessment.

d. JFP Force Availability Assessment. JFPs have approximately 2 weeks to complete sourcing, gain risk assessment approval (releasable draft), and forward draft information to the JCCA OPR (Joint Staff J-7), USTRANSCOM, and the supported commander. An additional week is provided to format and adjudicate the final sourcing solutions. Similarly, JFPs have approximately 2 weeks following the Adaptive Planning/Force Flow Conferences to create “above the line” sourcing solution briefing slides.

e. Combat Support Agencies Assessment. CSAs have approximately 2 weeks from the completion of the Adaptive Planning/Force Flow Conference to complete a risk assessment approval (releasable draft) and forward draft information to the JCCA OPR (Joint Staff J-7), USTRANSCOM, and the supported commander. An additional week is provided to format and adjudicate the final sourcing solutions. Similarly, JFPs have approximately 2 weeks following the Adaptive Planning/Force Flow Conferences to create “above the line” sourcing solution briefing slides.

f. Logistics Supportability Analysis. All standalone plans will undergo a logistics supportability analysis (LSA) of JCAs in accordance with the JSCP and JSCP Logistics Supplement. The Services and DLA will complete LSAs and integrate the output into a joint LSA for the combatant command to review. The joint LSA will be provided to USTRANSCOM to include in the movement requirements. For plans lacking a detailed LSA, the combatant command will identify specific logistics capability area limitations or constraints for review.

g. USTRANSCOM Transportation Assessment. USTRANSCOM has approximately 3 weeks to review the JFP force availability assessment and produce a transportation assessment.

h. Supported Commander Risk Drivers, Risk Assessment, and Mitigation Action. The supported commander has approximately 10 days following receipt of the JFP force availability assessments to complete risk drivers, the overall risk assessment, and mitigation action. As force readiness and availability are part of the risk calculus, much of the supported commander assessment can be completed prior to receiving the JFP force availability assessment.

i. Plan Assessment Issues. Joint Staff J-7 reviews the plan assessment throughout the development process to identify specific issues that need additional explanation or can be resolved by Joint Staff action. As appropriate, Joint Staff J-7 will prepare additional issues slides for inclusion in the briefing. Issue slides are reviewed (coordinated) with appropriate commanders.

j. Plan Assessment Service Coordination. Joint Staff J-7 begins coordination with Service representatives 2 to 3 weeks in advance of the JCS Tank. Early integration of each Service headquarters facilitates more efficient brief development by incorporating recommendations during the approval process, thereby preventing a late-breaking contentious issue from dominating the assessment.

k. Plan Assessment JCCAG Pre-Brief. Plan assessment is pre-briefed by Joint Staff J-7 JOWPD to JCCAG to ensure:

(1) All reasonable issues are being addressed or deferred for additional action.

(2) Consistency is validated across the risk assessment process.

(3) Risk assessment lessons learned and direct process changes are captured for future assessments.

1. JCS Tank Plan Assessment Briefing

(1) Joint Staff J-7 coordinates the final brief with all participating combatant commanders, Services, CSAs, and Joint Staff directorates prior to the JCS Paper Tank Briefing. JCS Tank briefs will be provided as required/requested.

(2) Joint Staff J-7 will make recommendations to individual combatant commands during brief development; however, the Joint Staff J-7 briefer will strictly represent the critical points and concerns as provided by the combatant commander during the actual brief.

(3) JCCA flag-level JCCAG leaders normally observe JCS Tank or Table Top Exercise proceedings, and an additional Joint Staff J-7 officer attends as the subject matter expert.

(4) A supported commander representative may attend the JCS Tank briefing but is not required.

8. After Action. Brief is posted to the Joint Staff J-7 and J-39 Web sites. Questions posed during the brief are answered immediately, answered through Joint Staff action, or are readdressed during the next scheduled plan assessment JCS Tank. Issues, top concerns, risk drivers, and recommended mitigation actions are inserted into the JCCA process for appropriate action.

9. JCCA Contingency Sourcing Responsibilities. Contingency sourcing is a manpower-intensive requirement that competes for resources with JFP execution sourcing responsibilities. As automated planning and sourcing tools become more accurate, contingency sourcing requests should diminish. However, present contingency sourcing requests exceed JFP resources. Contingency sourcing requests fill three general categories: combatant command requests to support Adaptive Planning/Force Flow Conferences, Chairman-level exercises with contingency sourcing requirements, and JCCA plan assessments. Combatant command requests are the most time-intensive requirement, followed by plan assessments, and exercises are the least intensive requirement. The GFMB is the arbiter of all sourcing requests. The JCCAG (Joint Staff J-7) is responsible for collecting all contingency sourcing requests and presenting the requests and a recommended sourcing solution quarterly to the GFMB for approval.

a. Quarterly Contingency Sourcing Requirements Message. Joint Staff J-7 will draft the requirements reflecting GFMB approval of the next quarter's contingency sourcing requirements, three successive quarters of sourcing requests, instructions for submitting sourcing requests, and the time line for the next GFMB.

b. JCCA Contingency Sourcing Requirement Recommendation. The recommendation captures all exercise requirements and effectively balances JCCA plan assessments with combatant commander contingency sourcing requests. The plan assessment schedule is adjusted when reasonable to accommodate combatant commander sourcing requests and use the Adaptive Planning Conference data as the force readiness availability and readiness basis for a plan assessment.



10. JCCA Plans Assessment Process Outline

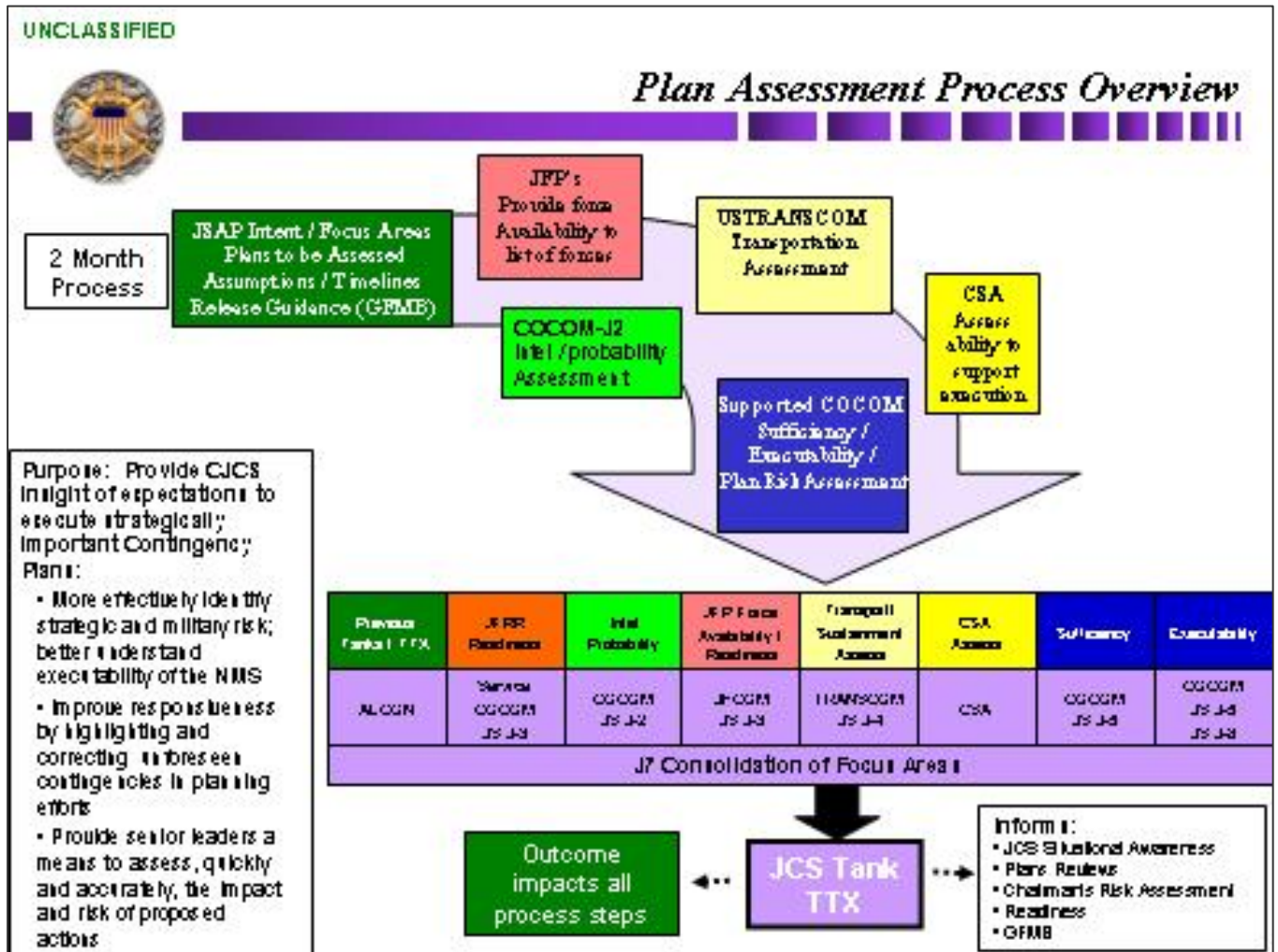

Figure D-A-3. Joint Staff J-7 Process Outline

11. JCCA Plans Assessment Notional Process Time Line

Event	OPR	Duration	Remarks
GFMB Approval	Joint Staff, J-7	2 Weeks	Time due to brief preparation
GFMB Approval Message	Joint Staff, J-7	2 Weeks	Time due to staffing for approval
JSAP Intent / Focus Areas	Joint Staff, J-7	2 Weeks	Coordination between primary participants
Contingency Sourcing Memorandum	Joint Staff, J-7	2 Weeks	Time due to staffing for approval
Plan Assessment Memorandum	Joint Staff, J-7	2 Weeks	Time due to staffing for approval
Intel Probability Assessment	Joint Staff, J-2	30 days	From notification of Plan Assessment Guidar
Supported COCOM Review	COCOM/NGB	45 days	From notification of Plan Assessment Guidar
CSA Assessment	CSA	30 days	From notification of Plan Assessment Guidar
Joint Force Provider - Availability of Forces	JFCOM, TRANSCOM, SOCOM, STRATCOM	30 days	In support of Contingency Sourcing - AP/FF
Contingency Sourcing Conference	COCOM / JFCOM/NGB	1 Week	
Adaptive Planning / Force Flow Conference	COCOM / TRANSCOM/NGB	2 Weeks	
Transportation / Sustainment Assessment	Joint Staff, J-4 / TRANSCOM	2 Weeks	
Joint Force Readiness Review	Joint Staff, J-3	Quarterly	
Sufficiency (Focus Areas)	Joint Staff, J-5	30 days	From notification of Plan Assessment Guidar
Executability (Focus Areas)	Joint Staff, J-5 / J-8	30 days	From notification of Plan Assessment Guidar
Socialization Briefs	Joint Staff, J-7	Weekly	Commence 30-45 days prior to intended com
JCS Tank / Table Top Exercise	Joint Staff, J-7	2 Weeks	Time due to brief preparation

\* Note many events occur in parallel

Figure D-A-4. Joint Staff J-7 Notional Process Time Line

ENCLOSURE E

JCCA OUTPUT SYNCHRONIZATION

1. General. The outputs of the JCCA are synchronized to inform other Joint Staff and OSD strategic documents and processes. These processes and documents include: Chairman's Risk Assessment through the Comprehensive Joint Assessment process (J-5), ARCCR and CGA process (J-8), and the Quarterly Readiness Report to Congress (OSD) (refer to Figure E-1 below). Through these informative relationships, the JCCA products are intended to:

- a. Ensure senior leaders and staffs are operating from a common readiness picture and facilitate senior leader decision making.
- b. Support the development of coordinated strategic documents.
- c. Contribute to alignment of the ends, ways, means, and risks to accomplishing the NMS.
- d. Contribute to fulfilling the statutory requirements of the Secretary of Defense and Chairman under Title 10, United States Code.

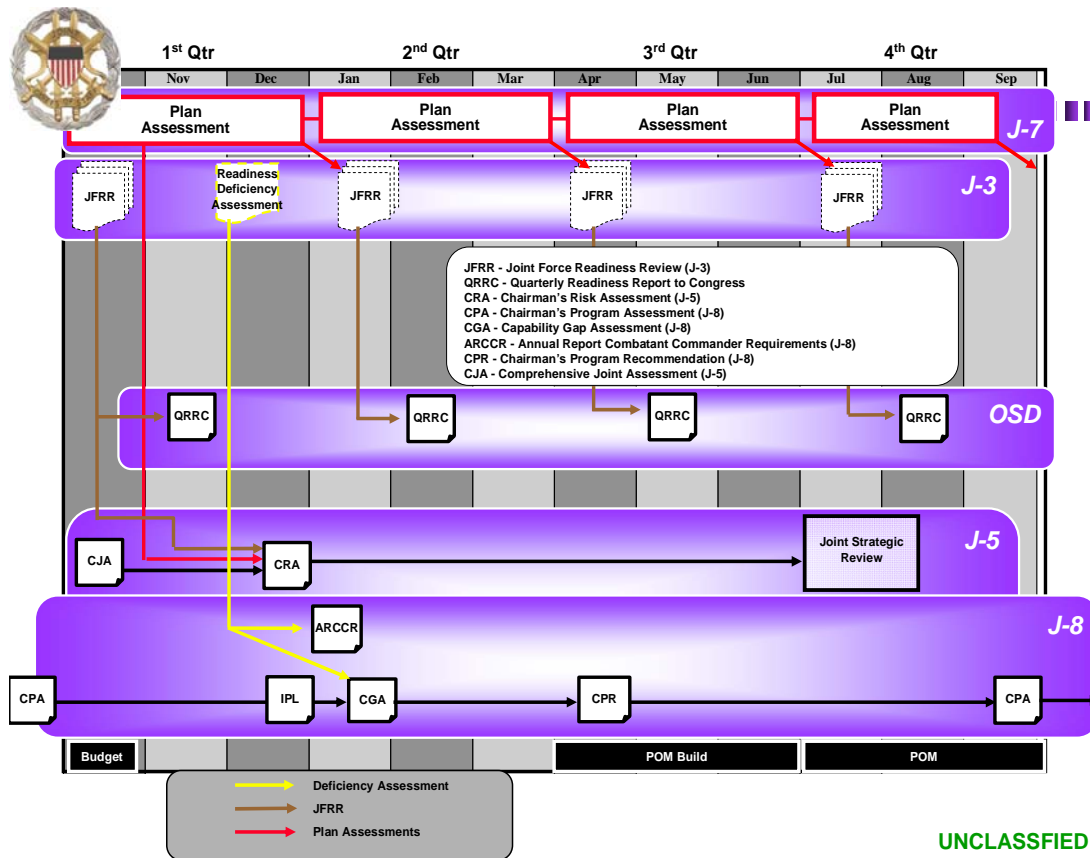

Figure E-1. JCCA Output Synchronization

2. Formal Linkage of JCCA Outputs. The formal linkage of JCCA products to strategic documents and processes is described below.

a. Chairman’s Risk Assessment. As required by 10 USC 153(b)(1), “the Chairman shall submit to the Secretary of Defense a report providing the Chairman’s assessment of the nature and magnitude of the strategic and military risks associated with executing the missions called for in the NMS.” To help fulfill this statutory requirement, the JCCAG will forward to the J-5 the JFRR quarterly and the results of plans assessments, as scheduled, to inform the Chairman’s Risk Assessment (Figure E-2).

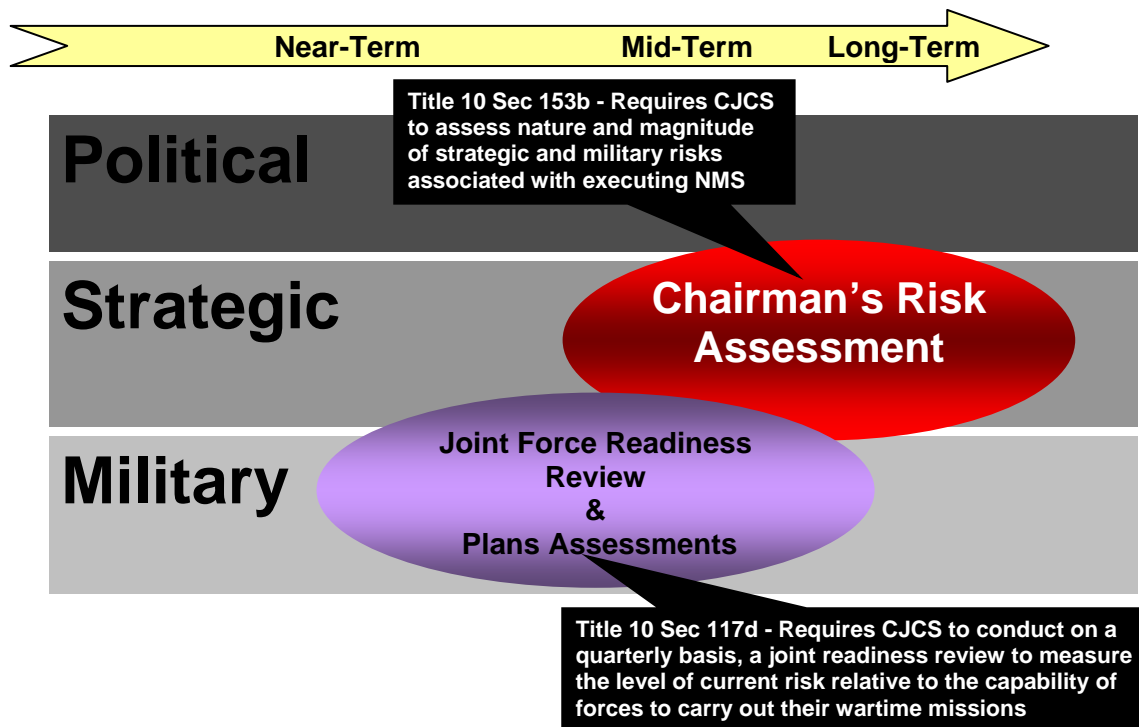

Figure E-2 Risk Framework

b. Annual Report on Combatant Command Requirements. As required by 10 USC 153(c)(1), “the Chairman shall submit to the congressional defense committees a report on the requirements of the combatant commands.” In addition to consolidating the combatant command IPLs, the report will “address each deficiency in readiness identified during the joint readiness review” (10 USC 117(d)(1)(a)). To assist in fulfilling this statutory requirement, the JCCAG will forward to the J-8, annually, the Readiness Deficiency Assessment identifying:

- (1) Combatant command readiness deficiencies reported over the fiscal year.
- (2) Combatant command readiness deficiencies closed over the fiscal year.
- (3) The status of combatant command readiness deficiencies not yet closed.

c. Capability Gap Assessment. The Readiness Deficiency Assessment will also be submitted to J-8 for inclusion in the Capability Gap Assessment. J-8 will bin C/S/A reported deficiencies in one of nine FCBs for analysis. FCB analysis results in the synthesis of deficiencies into larger capability gaps in

DOD's readiness to execute the NMS. The capability gaps and recommended actions are reviewed and endorsed by the DJ-8 at the Joint Capability Board and sent to the Joint Readiness Oversight Council (JROC) for approval (Figure E-3). The JROC's decision concerning disposition of each capability gap will be captured in a JROC memorandum that the DJ-8 will provide to the C/S/As. J-8 will also brief the JCCAG on the JROC's decisions. The CGA is an annual process; if a capability gap is not resolved, that gap is not automatically rolled over into the next CGA. If a C/S/A determines that an unresolved capability gap is still valid, the C/S/A will have to re-submit it in the next CGA. C/S/As will revalidate their deficiencies in DRRS annually not later than 15 October.

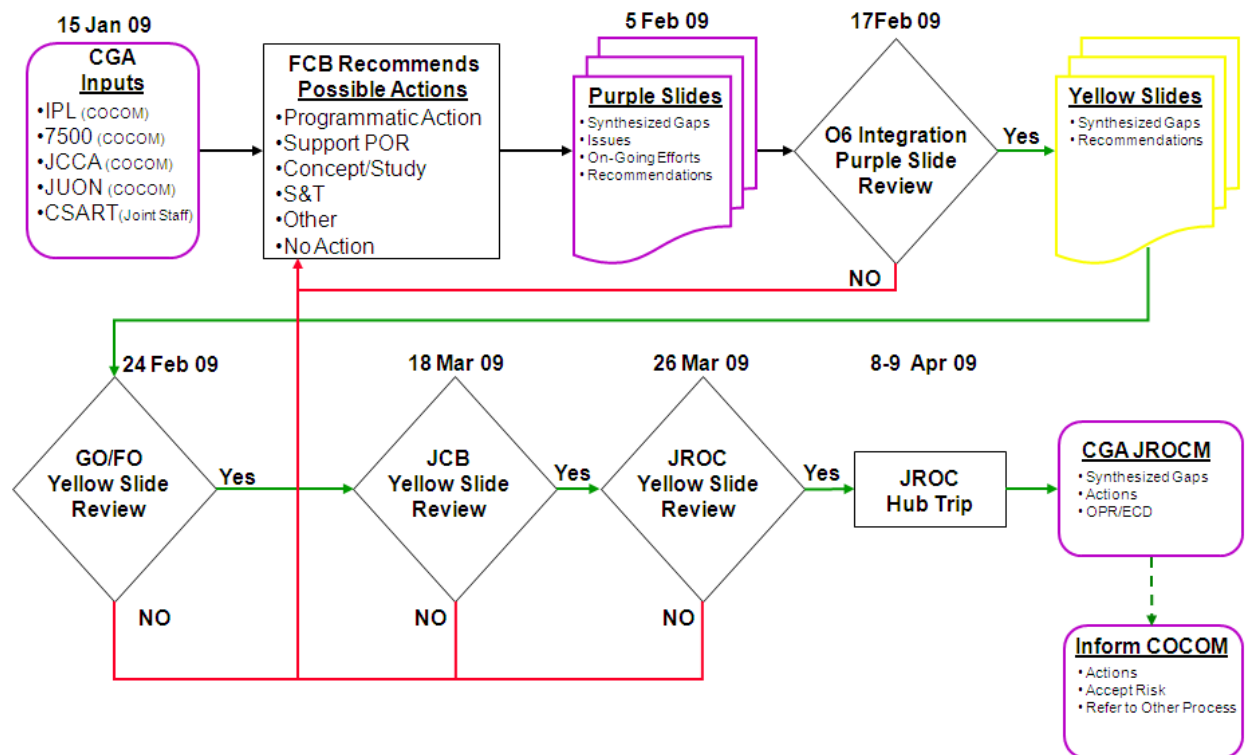

Figure E-3. Capability Gap Assessment Process

d. Quarterly Readiness Report to Congress. As required by 10 USC 482, “the Secretary of Defense shall submit to Congress a report regarding military readiness.” To assist in fulfilling this statutory requirement, the JCCAG will forward to DUSD(P&R), quarterly, a summation of the JFFR and cumulative listing of C/S/A submitted deficiencies.

3. The outputs of the JCCA are synchronized to inform other Joint Staff and OSD strategic documents and processes with the purpose of aligning readiness, force sourcing, risk, strategy, plans, and allocation and resourcing (Figure E-4).

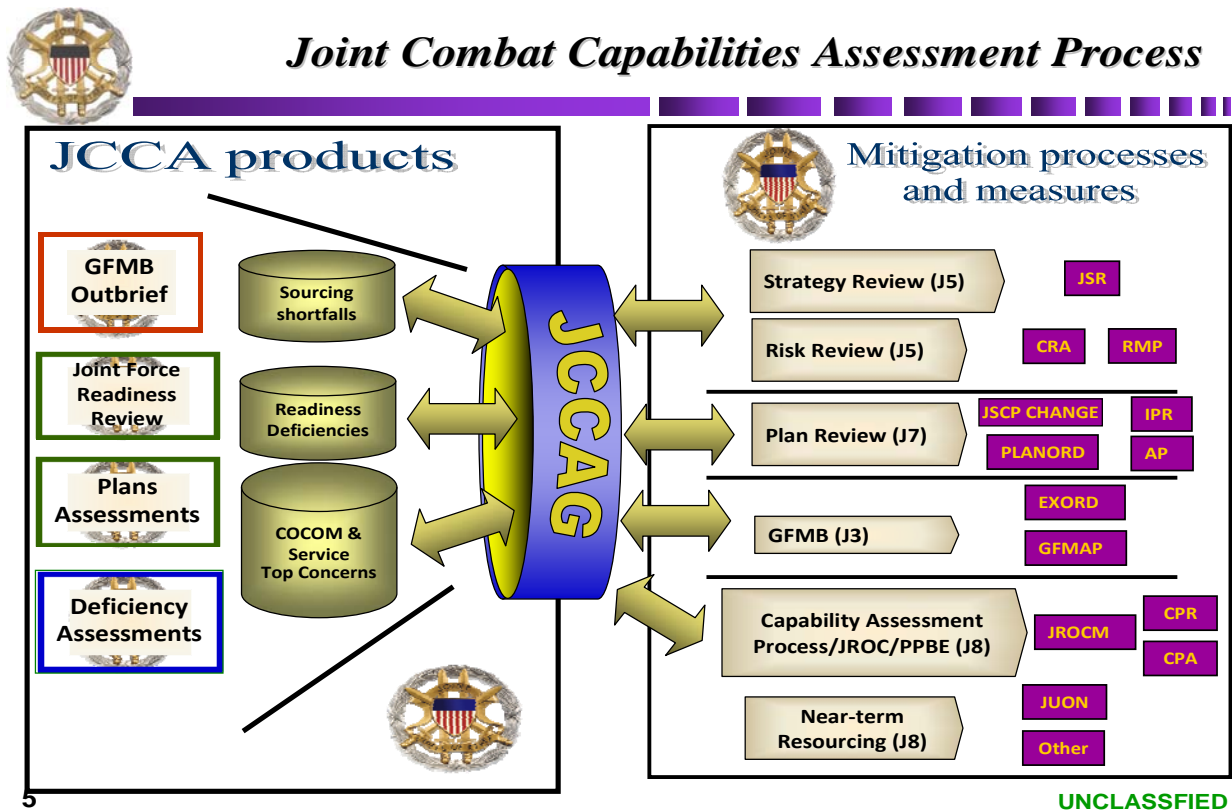

Figure E-4. JCCA Process Mitigation

(INTENTIONALLY BLANK)



ENCLOSURE F

REFERENCES

- a. Title 10, United States Code
- b. DOD Manual 8910.01, June 1998, "DOD Procedures for Management of Information Requirements"
- c. Joint Publication 1-02, 12 April 2001 as amended through 9 June 2004, "Department of Defense Dictionary of Military and Associated Terms"
- d. CJCSM 3150.02 series, "Global Status of Resources and Training System (GSORTS) Structure"
- e. CJCSI 3110.13 series, "Mobilization Guidance for the JSCP (U)"
- f. CJCSI 5714.01 series, "Release Procedures for Joint Staff and Joint Papers and Information"
- g. DODD 7045.14, Chapter 1, 28 July 1990, "The Planning, Programming, and Budgeting System (PPBS)"
- h. DODD 5149.2, 23 July 2002, "Senior Readiness Oversight Council (SROC)"
- i. JSM 5100.01 series, "Organization and Functions of the Joint Staff"
- j. CJCSI 3100.01 series, "Joint Strategic Planning System"
- k. CJCSI 3500.01 series, "Joint Training Policy for the Armed Forces of the United States"
- l. CJCSI 3500.02 series, "Joint Training Master Plan 2002 for the Armed Forces of the United States"
- m. CJCSM 3500.04 series, "Universal Joint Task List"
- n. DODD 7730.65, 3 June 2002, "Department of Defense Readiness Reporting System (DRRS)"
- o. DODI XXXX, "Department of Defense Readiness Reporting System (DRRS)"
- p. CJCSI 3137.01 series

(INTENTIONALLY BLANK)

## GLOSSARY

### ABBREVIATIONS AND ACRONYMS

ARCCR	Annual Report on Combatant Command Requirements
AMET	agency mission-essential task
AMETL	agency mission-essential task list
BCT	Brigade Combat Team
BN	Battalion
C2	command and control
C3	command, control, and communications
C4	command, control, communications, and computers
CCDR	combatant commander
CGA	Capability Gap Assessment
CJA	Comprehensive Joint Assessment
CJCS	Chairman of the Joint Chiefs of Staff
CJCSI	Chairman of the Joint Chiefs of Staff Instruction
CONPLAN	operation plan in concept format
CPA	Chairman's Program Assessment
CPG	Contingency Planning Guidance
CRA	Chairman's Risk Assessment
CRD	Commander's Required Date
CPR	Chairmen's Program Recommendation
CRS	Chairman's Readiness System
CSA	Combat Support Agency
CSG	Carrier Strike Group
DCMA	Defense Contract Management Agency (a CSA)
DDAT/HD	J-3 Deputy Director for Antiterrorism/Homeland Defense
DDGO	J-3 Deputy Director for Global Operations
DDRO	J-3 Deputy Director for Regional Operations
DDSO	J-3 Deputy Director for Strategic Operations
DDIO	J-3 Deputy Director for Information Operations
DEPOD	Deployment Order
DIA	Defense Intelligence Agency (a CSA)
DISA	Defense Information Systems Agency (a CSA)
DJ-3	Director, J-3, Operations Directorate
DJS	Director, Joint Staff
DLA	Defense Logistics Agency (a CSA)
DOD	Department of Defense
DPG	Defense Planning Guidance (replaced by SPG)
DRRS	Defense Readiness Reporting System
DTRA	Defense Threat Reduction Agency (a CSA)
DUSD	Deputy Under Secretary of Defense
DUSD(R)	Deputy Under Secretary of Defense for Readiness

ESORTS	Enhanced Status of Resources and Training System
EXORD	Execution Order
ESG	Expeditionary Strike Group
FCB	Functional Capabilities Board
GEF	Guidance for the Employment of the Force
GDF	Guidance for the Development of the Force
GFM	Global Force Management
GFMB	Global Force Management Board
GSORTS	Global Status of Resources and Training System
GTF	Gross Transportation Feasibility
HQ	headquarters
IAW	in accordance with
IPL	integrated priority list
IPR	In Progress Review
ISR	Intelligence, Surveillance, and Reconnaissance
JCA	Joint Capability Area
JCCA	Joint Combat Capability Assessment
JCCAG	Joint Combat Capability Assessment Group
JCIDS	Joint Capabilities Integration and Development System
JCS	Joint Chiefs of Staff
JFAST	Joint Flow and Analysis System for Transportation
JFP	Joint Force Provider
JFRR	Joint Force Readiness Review
JMET	joint mission-essential task
JMETL	joint mission-essential task list
JOPEs	Joint Operations Planning and Execution System
JROC	Joint Requirements Oversight Council
JSR	Joint Strategic Review
JSCP	Joint Strategic Capabilities Plan
JSPS	Joint Strategic Planning System
JUON	Joint Universal Operational Need
LAD	Latest Arrival Date
LSA	Logistics Supportability Analysis
MET	mission-essential task
METL	mission-essential task list
NDS	National Defense Strategy
NGA	National Geospatial-Intelligence Agency (a CSA)
NMS	National Military Strategy
NORAD	North American Air Defense
NSA	National Security Agency (a CSA)
NSS	National Security Strategy
OPLAN	operational plan
OPR	office of primary responsibility
OpsDepts	operations deputies
OPSEC	operations security

OPTEMPO	operations tempo
OSD	Office of the Secretary of Defense
PID	Plan Identification
POC	point of contact
POD	Port of Debarkation
POM	programmed objective memorandum
PPBE	planning, programming and budgeting execution
PRST	Personnel, Supply, Equipment Readiness, and Training
PTDO	Prepare to Deploy Order
QRRC	Quarterly Readiness Report to Congress
RA	readiness assessment
SORTS	Status of Resources and Training System
SPG	Strategic Planning Guidance
SROC	Senior Readiness Oversight Council
TSC	Theater Security Cooperation
TPFDD	Time-Phased Force and Deployment Data
TUCHA	Type Unit Characteristics File
UCC	unified combatant command
UCP	Unified Command Plan
UIC	Unit Identification Code
UJTL	Universal Joint Task List
UTC	Unit Type Code
USC	United States Code
USAFRICOM	U.S. Africa Command
USCENTCOM	U.S. Central Command
USEUCOM	U.S. European Command
USJFCOM	U.S. Joint Forces Command
USNORTHCOM	U.S. Northern Command
USPACOM	U.S. Pacific Command
USSOCOM	U.S. Special Operations Command
USSOUTHCOM	U.S. Southern Command
USSTRATCOM	U.S. Strategic Command
USTRANSCOM	U.S. Transportation Command
VCJCS	Vice Chairman of the Joint Chiefs of Staff

(INTENTIONALLY BLANK)