

BUREAU OF RECLAMATION  
FACILITIES INSTRUCTIONS, STANDARDS, & TECHNIQUES

**Volume 4 - 6**

# **WOOD POLE MAINTENANCE**

AUGUST 1992

# CONTENTS

<b>Section</b>	<b>Page</b>
I. Purpose .....	1
II. Introduction .....	1
2.1. General .....	1
2.2. Considerations .....	1
2.3. Inspection end Treatment Program for Wood Pole Structures .....	1
2.4. Reclamation Wood Pole Lines .....	2
2.5. Destructive Forces .....	2
III. Decay .....	2
3.1. Types of Decay .....	3
3.2. Detection of Decay .....	5
IV. Inspection of Structures .....	5
4.1. Preparation for Inspection .....	5
4.2. Identification of Substandard Structures .....	5
4.3. Groundline Inspection and Treatment .....	5
4.4. Serviceability of Poles .....	7
4.5. Pole-Top Inspections .....	8
4.6. Crossarm Inspection and Treatment .....	9
V. Determining the Serviceability of Decayed Poles .....	9
5.1. General .....	9
5.2. Decay Classification .....	9
5.3. Permissible Reduced Circumference Safety Factors .....	9
VI. Approved Treatments .....	12
6.1. Decay Maintenance .....	12
6.2. Other Maintenance .....	15
VII. Reporting .....	15
7.1. Forms .....	15
Appendix A-Protecting Wood Poles with Vapam (Pole Gas) .....	19
A-1. Introduction .....	19
A-2. Treatment .....	19
A-3. Equipment and Materials .....	19
A-4. Procedure .....	19
A-5. Safety .....	20

## CONTENTS - Continued

Section	Page
Appendix B - Manufacturers, Product Names, and Ingredients of Toxic Fungi-Killing Products for Groundline Treatment of Standing Wood Poles .....	21
Appendix C - Wood Pole Woodpecker Damage Repair .....	23

### LIST OF FIGURES

Figure	Page
1. Typical internal decay in a 20-year old western red cedar pole .....	3
2. Internal decay In a Douglas fir pole that was in service about 11 years .....	3
3. The Poi-Tek sonic tester .....	4
4. Cedar shavings .....	5
5. Douglas fir shavings .....	5
6. Longitudinal cut through pole with a decay pocket .....	7
7. Severely decayed pole .....	8
8. Pole with advanced decay pocket .....	8
9. Pole with minor decay .....	8
10. Stub reinforcing of wood poles .....	14
11. Wood pole inspection and maintenance report .....	16
12. Instructions for using BPA 1007 .....	17
13. Applying Vapam treatment .....	19

### LIST OF TABLES

Table	Page
1. Pole circumference SF (safety factors) .....	10
2. Reduction in measured circumference of pole to compensate for external pocket .....	11
3. Reduction in measured circumference of pole to compensate for hollow heart .....	11
4. Reduction in measured circumference of pole to compensate for enclosed pocket .....	11

## I. PURPOSE

The purpose of this volume is to identify destructive forces that affect wooden transmission structures and to present constructive methods for eliminating or successfully combating these forces. This volume also outlines a preventive maintenance program based on periodic tests and treatment of wood poles to discover and treat decay and thus prolong the service life of structures.

## II. INTRODUCTION

**2.1. GENERAL.** A systematic program of pole inspection and maintenance is essential for the following reasons:

*a. Safety to life and property.-Poles should be maintained above definite minimum strength requirements.*

*b. Efficient service within the system.-Outages or service interruptions due to pole failures should be kept to a minimum.*

*c. Economical operation.-The number of pole replacements should not be excessive and the maximum useful life should be obtained from every pole.*

**2.2. CONSIDERATIONS.** In this volume, methods of inspection and maintenance of standing poles have been considered. Information is included on the causes of pole failures; intelligent application of this information will aid in increasing average pole life. Much of the information contained in this volume has been compiled from Bonneville Power Administration Maintenance Standard No. 63020-1, "Wood Pole Structure Maintenance," and Rural Electrification Administration Bulletin 161-4, "Pole Maintenance." Adherence to the general rules will eliminate much guesswork; nevertheless, good judgment should be used in all cases, since the condition and remaining useful life of similar poles will vary widely.

**2.3. INSPECTION AND TREATMENT PROGRAM FOR WOOD POLE STRUCTURES.** Since most Reclamation organizations responsible for transmission line

maintenance are not adequately staffed to accomplish a full-scale inspection and treatment program for wood pole lines, the following two-stage program may be more appropriate for Reclamation use:

### 2.3.1. Stage 1- Spot check and evaluation.-

*a. Spot check.-Reclamation personnel should spot check approximately 10 percent of the structures (or one structure per mile) in a given line section in accordance with the inspection procedures outlined in [section IV](#) and the treatment methods discussed in [section VI](#) and [appendix A](#). All poles in each spot-checked structure should be checked and evaluated.*

*b. Evaluation.-Data from spot checks on a given line section should be carefully evaluated to obtain a statistical estimate of the condition of all poles in the line section. If more than 10 percent of the poles are estimated to have groundline decay, or more than 10 percent to have above-ground decay or other defects, consideration should be given for full-scale inspection and treatment by contract.*

### 2.3.2. Stage 2- Specifications and contract.-

*a. Specifications.-A copy of sample specifications for inspection and treatment of wood poles will be provided by the General Sciences Division, Operation and Maintenance Branch, Denver Office, upon request. These specifications should be modified as necessary to cover specific problems and local conditions.*

*b. Contract.-Full-time inspection of all contractor activities by knowledgeable Reclamation employee(s) is essential to obtaining full value from an inspection and treatment contract, as well as ensuring safety for personnel and reliability of the power system,*

## 2.4. RECLAMATION WOOD POLE UNES.

Many Reclamation wood pole lines were constructed in the late 1940's and early 1950's. During this period, most pole suppliers changed from the use of creosote to pentachlorophenol as a preservative, and adequate quality control measures had not been established to ensure optimum preservative treatment. Also, during that period, poles were in short supply, and many species of timber were used for poles. In some instances poles of western red cedar, Douglas fir, lodgepole or southern pine, and western larch were used in a given line section. Throughout this bulletin, two species, western red cedar and Douglas fir, are discussed. For our purposes, pine and larch poles should be considered in the same category as Douglas fir unless otherwise indicated.

**2.5 DESTRUCTIVE FORCES.** One of the most destructive forces affecting wooden transmission structures is decay. It will generally progress at a predictable rate and its advance can be readily diagnosed in the field at all but the very early stages.

Also, the damage caused by termites, beetles, ants, and woodpeckers can be significant and should receive attention in proportion to the influence of these pests upon the poles in a given area.

Early detection of decay or damage and treatment of it is by far the most important and successful step in extending pole life.

## III. DECAY

### 3.1. TYPES OF DECAY.-

**3.1.1. Internal decay.-**Internal deterioration of treated poles is due very largely to development of checks after treatment that expose the untreated center portion of the pole to fungi and insects. Although internal decay may occur above ground as a result of checks or holes drilled after treatment, the

critical groundline zone of poles is most subject to such deterioration because moisture conditions near and below groundline are most favorable to growth of wood-destroying organisms.

Most wood-destroying organisms are simple plants, called fungi. They obtain all their food from the wood they live in. Unlike other plants, fungi develop from spores (seeds) which germinate, establish extensive root-like systems within the wood, and eventually produce microscopic size spores by the millions. Sound wood may become infected by spores, or by direct contact with infected material, including contaminated test equipment.

During the progress of decay, wood first loses its luster (looks "dead"), then, as change in color becomes progressively more pronounced, the wood loses its characteristic structure and strength, until only a soft whitish or easily crumbled brown mass remains. Usually the decayed wood is wetter than adjacent sound wood. In cedar poles, internal decay usually appears as brown pockets of advanced decay with little surrounding areas of partially decayed wood (fig. 1). In Douglas fir, on the other hand, pockets of advanced decay may be surrounded by large areas of wood in various stages of decay (fig. 2). In some fir poles, most of the cross section may contain decay in the earlier stages but with advanced decay limited to a small area. Most frequently, insects such as termites and carpenter ants are also present in the decayed zone.

**3.1.2. External decay.-**In any species of timber, external decay results from using a poor preservative or from a low absorption of the preservative by the timber. In older poles, external decay is a consequence of gradual loss of most of the preservative in the sapwood through leaching, evaporation, and chemical change. In butt-treated cedar poles, a softening of the sapwood known as "shell rot" occurs in the upper untreated portion of the pole. Such decay starts in the inner sapwood where air and moisture conditions promote fungus growth, and eventually extends to the outer sapwood.

**3.1.3. Groundline decay.-**In most cases, the first occurrence of decay will be just below the groundline. This is where the conditions of

moisture, temperature, air, and the absence of direct sunlight are most favorable to the growth of fungi. Unfortunately, this is a portion of the pole usually hidden from view and it is close to the natural breaking point of a pole under strain. Thus, it is the most critical part of the pole and warrants special inspection and maintenance.

**3.2. DETECTION OF DECAY.** Two methods are generally used to determine the presence and the degree of decay in poles. Sounding a pole with a hammer, mechanical sounding tool, or electronic sonic pole tester will usually detect the presence of decay. Boring the suspect pole with a brace and bit or an increment borer will confirm the presence and determine the degree of the decay.

**3.2.1. Sounding.**-Experienced personnel can detect internal decay pockets by using a 1- or 2-pound hammer to make sound tests above ground or at groundline after excavation. A mechanical device, such as the "M-pact-O Pole Sounder" (marketed by the Engineers Tools Corp., Lake City, Iowa), can be used for grounding sounding without excavation.

The sonic pole tester (such as the "Pol-Tek," distributed by the Chapman Chemical Co., Memphis, Tenn.) is a device that is used on poles and crossarms scheduled for periodic testing. Basically, this instrument is a sonic generator which injects a sound impulse into a pole and then records the time required for this impulse to pass through the pole and impinge on a receiving unit (fig. 3). The composition and homogeneity of the wood in addition to its thickness will determine the time for propagation of the impulse through the poles.

Tests indicate that while the sonic pole tester will not always indicate the degree of decay and its extent, with a high degree of accuracy it will pick out poles which are decaying or have internal voids, cracks, or fractures which may or may not decrease the strength of the pole significantly. 'the instrument does not register any pole as good when it actually contains any signifi-

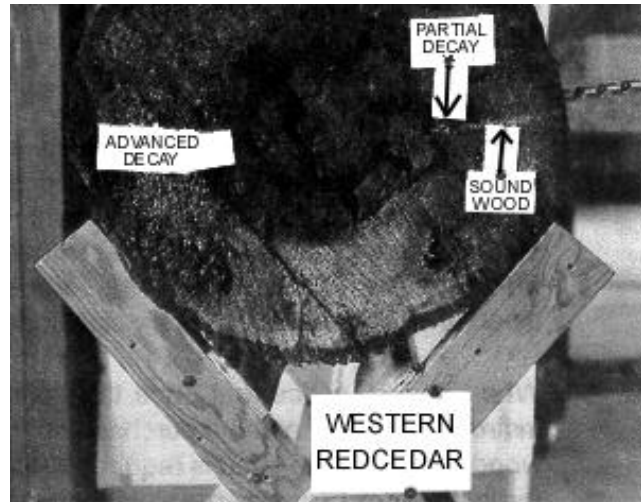

Figure 1. Typical internal decay in a 20-year-old western red cedar pole. Areas of advanced decay are surrounded by narrow zones of wood in early states of decay.

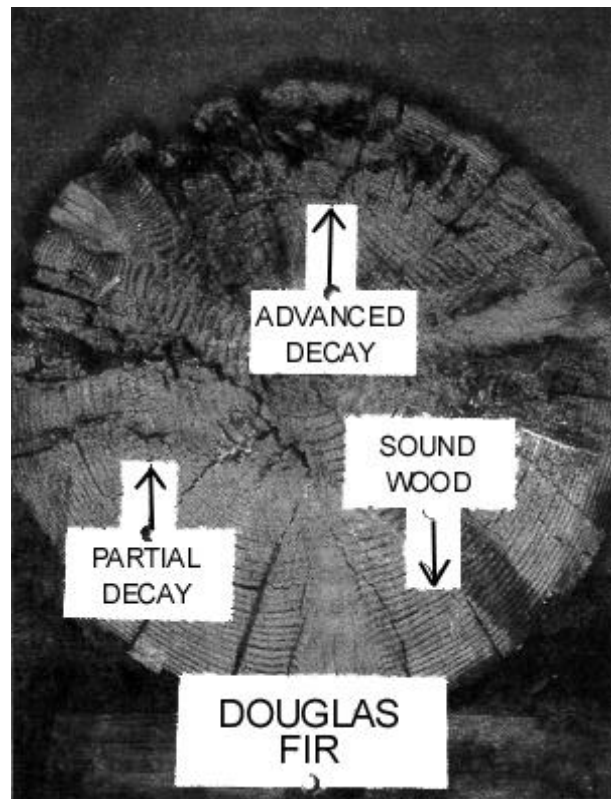

Figure 2. Internal decay in a Douglas fir pole that was in service about 11 years. Areas of advanced decay are surrounded by wide zones of wood in earlier stages of decay.

cant amount of internal decay. Thus, only poles which DO NOT TEST GOOD should be subsequently bored to conclusively establish the presence and extent of decay or identify the cause of the "bad reading."

**3.2.2. Boring.**-Boring a pole at the locations where "bad" soundings were obtained will clearly establish the type and extent of decay. Not only are the materials removed from the bore hole significant, the borer as it penetrates the wood is equally significant.

When boring, notice that once the boring instrument has obtained a purchase on the wood, considerable effort is required to turn the instrument; however, the bit will advance without external pressure. Less effort may be required as the bit penetrates because of the increasing moisture content of the wood; however, an abrupt reduction in force required to turn the instrument may indicate that the bit has entered wood in the early stages of decay.

Eventually, the bit may cease to penetrate on its own because of complete loss of purchase. Additional pressure on the bit may be necessary to maintain its advance into the decayed wood. Wood in the advanced stages of decay will allow the bit to penetrate it by pressure alone.

#### **3.2.2.1. Precautions when boring.-**

(1) Keep boring instruments sharp. As bits become dull, the more difficult it is to distinguish between sound and decayed wood.

(2) In certain cases where the sonic tester does not clearly indicate the outline of internal defects, several borings may be necessary to determine how far various stages of decay extend within the pole.

(3) Wood texture, color, and moisture content vary greatly in poles so that no single set of distinguishing characteristics can be applied to all poles.



Figure 3. The Pol-Tek sonic tester.

(4) Since collections of shavings during boring of poles in the field are difficult, stop boring as soon as a suspicious area is reached and remove all shavings to that point for examination. Continue boring by stages to facilitate the removal of unmixed shavings.

(5) Treat and plug all holes to prevent infection of sound poles.

#### **3.2.2.2. Interpreting the boring materials.-**

Shavings removed from sound wood usually are uniform in size, fibrous, and require considerable force to break. As decay becomes more advanced, a higher proportion of fines appear mixed with the shavings, which become progressively easier to crumble. Advanced decay usually results in particles of small size that lack cut surfaces and tend to pack in the flutes of the auger.

Cores removed with an increment borer usually remain intact until advanced stages of decay are reached. Earlier stages of decay may be determined by breaking off sections of the core and crumbling them between the fingers. Sound wood retains much of its fibrous nature, is difficult to tear apart, and does

not crumble into fine particles. Decayed wood breaks easily and crumbles.

Figure 4 shows shavings removed with an auger from a cedar pole; figure 5 shows the same from a Douglas fir pole. Sound fibrous wood in each case is on the left. Decayed wood, which easily crumbles to small particles, can be seen on the right.

#### IV. INSPECTION OF STRUCTURES

##### 4.1. PREPARATION FOR INSPECTION.

Prior to the regular inspection, determine which poles or structures (for obvious reasons) will be replaced in the near future and either eliminate them from the program altogether or identify them for reduced preventive maintenance.

##### 4.2. IDENTIFICATION OF SUBSTANDARD STRUCTURES.

Mark with a wide band of red paint, or similar identification, any pole or crossarm which inspection as follows identifies as being sufficiently decayed or deteriorated to require replacement. Refrain from climbing such a structure or working from a marked crossarm unless adequate measures have been taken to prevent an accident.

NOTE: When replacing a deteriorated pole with a new pole, DO NOT cut off the top of the new pole.

##### 4.3. GROUNDLINE INSPECTION AND TREATMENT.-

###### 4.3.1. Inspection frequency.-

	Frequency in years	
	Cedar	Fir and larch
Initial	15	12
Reinspect-Sound pole	12	12
Reinspect-Minor decay	6	6

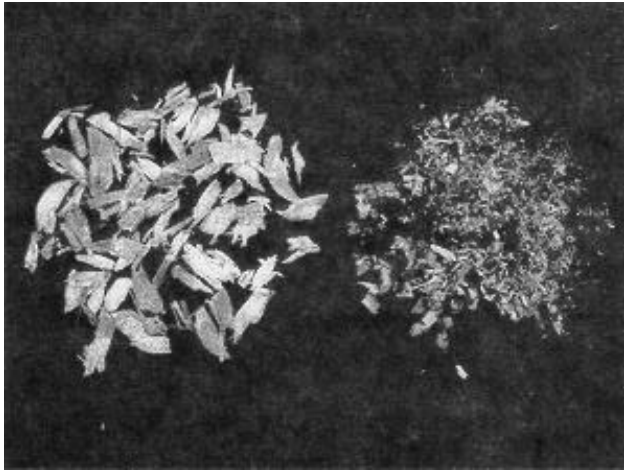

Figure 4. Cedar shavings.



Figure 5. Douglas fir shavings.



#### 4.3.2. Procedure.-

**4.3.2.1. Preliminary structure evaluation.-** Examine entire structure from ground for the following defects:

- (1) Excessive checking, cracking, or splitting; especially deep checks in full-length-treated poles showing white wood.
- (2) Woodpecker holes and evidence of insect colonies.
- (3) Excessive shell decay above ground-Note degree.
- (4) Lightning damage.
- (5) Damaged or corroded guying.
- (6) Damaged bracing.
- (7) If in through-drilled poles the back-fill extends above the drilled section-REMOVE!
- (8) Any other obvious defects.

**NOTE:** If pole top and crossarm defects cannot readily be assessed from the ground, climb the pole for a thorough analysis after determining that it is safe to do so.

**4.3.2.2. External decay.-**Where surface decay is found at the groundline, excavate around the deteriorated section of the pole. Measure and record the pole circumference at the groundline; remove the surface decay down to sound wood, and record the new circumference of the pole.

If the remaining pole section has sufficient circumference, as determined from the tables in section V, inspect for internal decay. If internal decay is found, treat the decayed section as outlined in [section 6.1.1.](#), "Groundline Treatment."

If the groundline circumference is below the permissible minimum, the pole should be promptly replaced or stubbed.

#### 4.3.2.3. Internal decay.-

*a. Testing methods.-*In addition to visual observation, inspection methods include sounding and boring when necessary. The sounding test is fast and completely nondestructive, but it will not reveal the extent and type of defect. It will not indicate whether the pole has a harmless void or a large and dangerous decay pocket. Boring will reveal details on the type and severity of decay, but it is rather slow, somewhat destructive, and may conceivably introduce decay-causing organisms into a sound pole.

By testing all poles first by sounding and then following up by boring only poles which failed the sounding test, all poles may be evaluated with a minimum amount of unavoidable damage and a reduced possibility of infecting healthy poles. If a sonic tester is available, use it first to eliminate good poles from the maintenance program, and resort to boring only when necessary to confirm decay.

*b. Procedure.-*Look for checks which extend into the ground or terminate just above groundline. Take a reading with the sonic tester between the widest check and the opposite side of the pole and another at right angle to the check. If the sonic tester indicates no serious internal decay above ground, the next step is to excavate deeper in dry or porous soils, and this can be determined as the work progresses. The hole should be wide enough to permit use of the borer below groundline if boring is necessary. Care must be taken not to cut or disturb the ground wire. Take two additional readings with the sonic tester. If both readings indicate sound wood, the test is complete.

All poles thus excavated and not condemned should be given a groundline treatment. Excavating aerates the soil and encourages the growth of fungi, and the cost of such maintenance is largely taken care of when crew and equipment are at the site and excavating has been performed. If either of the two readings indicates a defect, take additional readings to better localize the defect and its extent.

Once the defect is established and localized, bore into the pole quarters in which the irregularity was noted to determine its nature and extent. If decay is found, bore the other two quarters and also bore one hole 2 feet above the decay pocket. From these borings determine the serviceability of the pole (see sec. 4.4). Finally, inject Vapam (pole gas), as specified in [appendix A](#), into the bore holes and internal voids or pockets. Another approximately equal treatment, such as "Os-mose Hollow Heart," may be used. After internal treatment, drive tight-fit-ting preservative-impregnated plugs into the bore holes.

**NOTE:** It is suggested that Vapam or a penta solution be injected into the bored holes even if no sign of decay is detected. Decay may also be found between the groundline and the top of a pole. Spot checks should also be made at the bottom of cracks terminating above ground. If decay is found, a complete inspection should be programmed.

**4.4. SERVICEABILITY OF POLES.** From the boring results, determine the amount of sound wood left. Figure 6 shows a typical pocket of decay. [Figures 7, 8, and 9](#) show varying degrees of decay.

**NOTE:** When boring at a 45° angle, the thickness of good wood is approximately two-thirds of the bit length ([fig. 6](#)).

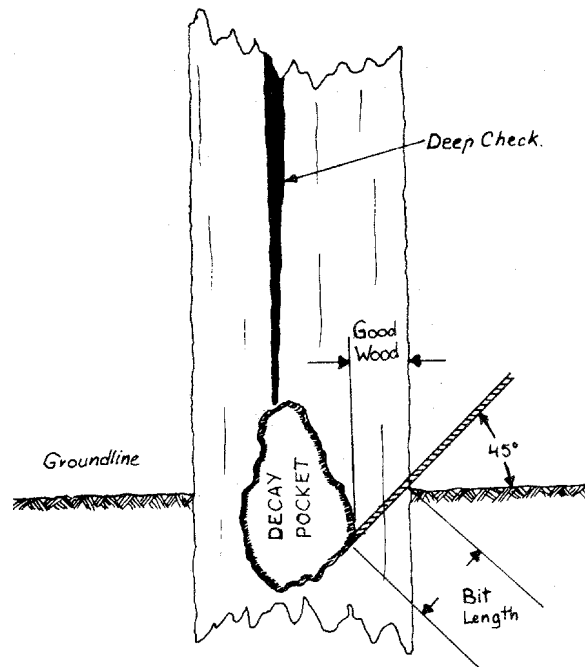

Figure 6. Longitudinal cut through pole with a decay pocket.

Poles are severely decayed and should be replaced immediately (a) if any quarter has 2 inches or less of good wood and the decay as shown in [figure 7](#) is more than 10 percent of the bored cross section or (b) if at least three quarters have 3 inches or less of good wood. Mark poles like the one in [figure 7](#) with a band of red paint or similar identification.

**NOTE:** To determine the decayed area in [figure 7](#), multiply the maximum distance across the decay pocket by the minimum distance across it.

Poles with advanced decay pockets ([fig. 8](#)) should be programmed for routine replacement, if all quarters have less than 5 inches but more than 3 inches of good wood. Mark poles like the one in [figure 8](#) with a band of red paint or similar identification and replace the poles within 3 years.

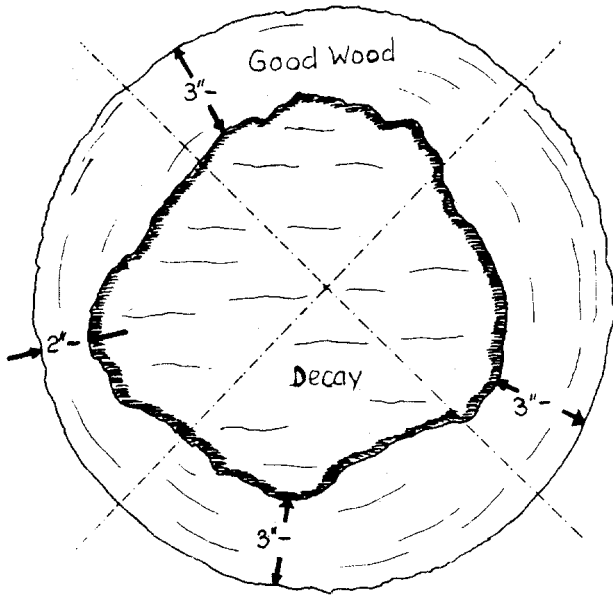

Figure 7. Severely decayed pole.

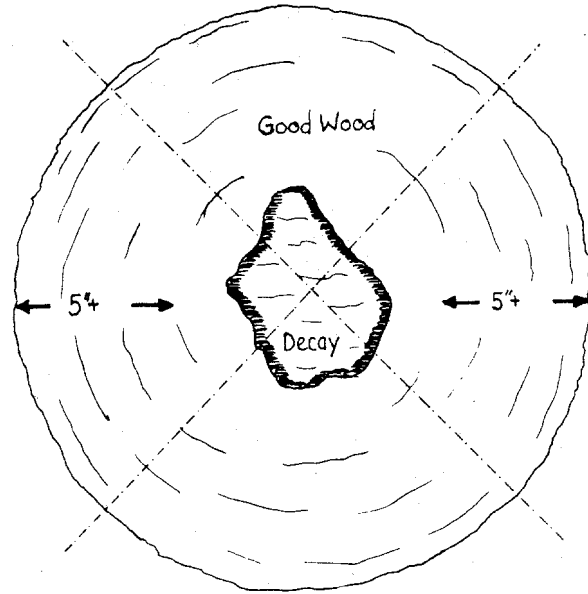

Figure 9. Pole with minor decay.

Section V gives criteria, instructions, and tables for determining the serviceability of wood poles with decay at the groundline.

#### 4.5. POLE-TOP INSPECTIONS.-

**4.5.1. Butt-treated cedar poles.** - Schedule inspections when performing above-ground structure inspections, when inspecting or performing maintenance at the top of the structure, or when patrols indicate a need for a more detailed inspection.

**4.5.2. Full-length treated fir poles.** - Spot check pole tops for decay at the time the groundline or routine structure inspection is made. When general pole-top deterioration appears extensive, program a pole-top treatment. Keep in mind that poles which have been cut off after b'eatment are especially susceptible to decay.

Check for possible hazardous cracks, especially in line with drilled bolt holes. Check all bolt holes for decayed wood; not any white or untreated wood in checks and look for shell rot, particularly on the weather side of the structure. Note any other damage

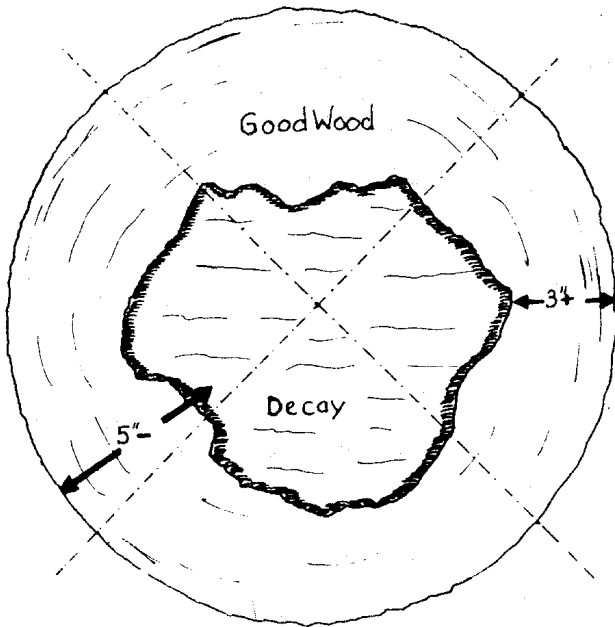

Figure 8. Pole with advanced decay pocket.

that would affect structure integrity. Take sonic readings in lines with the largest cracks and follow up with a bore test if decay is suspected.

**4.6. CROSSARM INSPECTION AND TREATMENT.** Inspect crossarms during structure inspections or when conditions warrant a special inspection. Make periodic inspections of spar arms and X-braces. Inspect the crossarm thoroughly from each pole in case of a multiple structure. Check crossarms for any damage caused by lightning, woodpeckers, etc. Inspect for checks, splits, or decay pockets, particularly at holes bored through the arm.

Note checks across the top of the crossarm which may hold moisture. Bore the crossarm from below to drain the moisture. Keep bore holes at least 1 foot apart. Use increment borer or brace and bit to inspect for decay.

**NOTE:** Because of the scarcity and high cost of quality wood spar arms, the Mid-Pacific region has been replacing deteriorated spar arms with I-beams of a high-strength, corrosive-resistant steel (Cor-Ten).

## V. DETERMINING THE SERVICEABILITY OF DECAYED POLES.

**5.1. GENERAL.** The decision to treat or replace a decayed pole shall depend upon the remaining strength or serviceability of the pole. The permissible reduced circumference of a pole is a good measure of serviceability; it may be determined by using the following discussion and tables.

**5.2. DECAY CLASSIFICATION.** Decay at the groundline shall be classified as:

- (1) General external decay,
- (2) External pocket,
- (3) Hollow heart, or
- (4) Enclosed pocket.

External decay may extend around the pole and cover a large area of the circumference or it may be limited to a small area representing only a portion of the circumfer-

ence. If the decay is limited to a portion of the pole not exceeding 6 inches in width and 5 inches in depth, it shall be classified as an "External Pocket," otherwise, external decay shall be classified as "General External Decay."

### 5.3. PERMISSIBLE REDUCED CIRCUMFERENCE SAFETY FACTORS.

Wood pole transmission lines are designed using a pole strength safety factor of 4 (SF 4), and the groundline circumference of a pole is used as a measure of pole strength. [Table 1](#) shows the relationship between reduced circumferences (caused by general external decay) and reduced safety factors. Circumference reductions to compensate for other categories of decay, [tables 2, 3, and 4](#), should be applied to the circumferences in [table 1](#) to determine the resultant reduced circumference and the corresponding pole safety factor.

If the reduced circumference indicates a pole safety factor less than that specified following [table 1](#), the pole should be replaced or stubbed immediately. Poles meeting or exceeding the specified safety factors should be treated as specified in [section 6.1.1](#) or [appendix A](#), and scheduled for reinspection as outlined in [section 4.3.1](#).

The tables should be used in accordance with the following instructions:

**5.3.1. General external decay.** - After cutting away all decayed wood, measure the circumference above or below the decayed section to determine the original (SF 4) circumference. Then measure around the pole where the decay was removed; this measurement is the reduced circumference. Check the original and reduced circumference. Check the original and reduced circumferences against [table 1](#).

**5.3.2. External pocket.** - Remove decayed wood and make measurements of the depth and width of the pocket. Measure the pole for the original (SF 4) circumference. Refer to [table 2](#) to determine the circumference reduction. After the circumference

Table 1 .-Pole circumference SF (safety factors)

Original circumference (inches)	Reduced circumference (inches)					
	SF4	SF3.5	SF 3	SF2.65	SF2.5	SF2
30.0	28.7	27.3	26.1	25.6	23.8	21.6
31.0	29.7	28.2	27.0	26.5	24.6	22.3
32.0	30.6	29.1	27.9	27.4	25.4	23.0
33.0	31.6	30.0	28.8	28.2	26.2	23.8
34.0	32.5	30.9	29.6	29.1	27.0	24.5
35.0	33.5	31.8	30.5	29.9	27.8	25.2
36.0	34.4	32.7	31.4	30.8	28.6	25.9
37.0	35.4	33.6	32.3	31.6	29.4	26.6
38.0	36.3	34.5	33.1	32.5	30.2	27.4
39.0	37.3	35.4	34.0	33.3	31.0	28.1
40.0	38.3	36.3	34.9	34.2	31.8	28.8
41.0	39.2	37.3	35.7	35.1	32.5	29.5
42.0	40.2	38.2	36.6	35.9	33.3	30.2
43.0	41.1	39.1	37.5	36.8	34.1	31.0
44.0	42.1	40.0	38.4	37.6	34.9	31.7
45.0	43.0	40.9	39.2	38.5	35.7	32.4
46.0	44.0	41.8	40.1	39.3	36.5	33.1
47.0	45.0	42.7	41.0	40.2	37.3	33.8
48.0	45.9	43.6	41.8	41.0	38.1	34.6
49.0	46.9	44.5	42.7	41.9	38.9	35.3
50.0	47.8	45.4	43.6	42.7	39.7	36.0
51.0	48.8	46.3	44.5	43.6	40.5	38.7
52.0	49.7	47.2	45.3	44.5	41.3	37.4
53.0	50.7	48.2	46.2	45.3	42.1	38.2
54.0	51.6	49.1	47.1	48.2	42.9	38.9
55.0	52.6	50.0	47.9	47.0	43.7	39.6
56.0	53.6	50.9	46.8	47.9	44.4	40.3
57.0	54.5	51.8	49.7	48.7	45.2	41.0
58.0	55.5	52.7	50.6	49.6	46.0	41.8
59.0	56.4	53.6	51.4	50.4	46.8	42.5
60.0	57.4	54.5	52.3	51.3	47.6	43.2

**PERMISSIBLE REDUCED CIRCUMFERENCE SAFETY FACTORS**

No single pole shall have SF less than 2.65

No H-structure shall have SF less than 2.65 and no pole shall have SF less than 2.

For H-structures, add the SF's for each pole and divide by 2 to obtain the structure SE For tension-type structures (dead ends), no pole shall have SF less than 2.65.

reduction is determined, subtract it from the original (SF 4) circumference to arrive at the reduced circumference against table 1.

pocketseparately and add them to get the total reduction.

For more than one external decay pocket, determine the reduction for each

**5.3.3. Hollow heart.** - When hollow heart is found, determine the shell thickness and

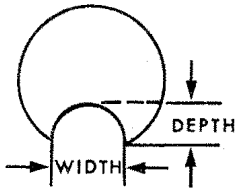

Table 2.—Reduction in measured circumference of pole to compensate for external pocket

Width of pocket (inches)	1					2					3					4					5					6				
Depth of pocket (inches)	1	2	3	4	5	1	2	3	4	5	1	2	3	4	5	1	2	3	4	5	1	2	3	4	5	1	2	3	4	5
Measured circumference of pole (inches)	Reduction in circumference (inches)																													
30 to 40	1	1	1	2	2	1	2	2	3	3	2	3	4	4	4	2	4	5	5	6	3	5	6	7	8	5	7	8	9	10
40 to 50	1	1	1	2	2	1	2	2	3	3	2	3	3	4	4	2	3	4	5	6	3	4	5	6	7	3	5	6	7	8
50 to 60	1	1	1	2	2	1	2	2	3	3	2	3	3	4	4	2	3	3	4	5	3	4	4	5	6	3	4	5	6	7

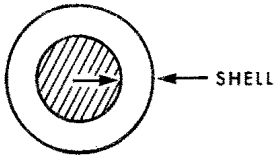

Table 3.—Reduction in measured circumference of pole to compensate for hollow heart

Measured thickness of shell (inches)	3	3-1/2	4	4-1/2
Measured circumference of pole (inches)	Reduction in circumference (inches)			
30 to 40	2	1	0	0
40 to 50	3	2	1	0
50 to 60	4	3	2	1

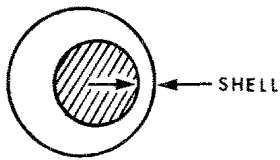

Table 4.—Reduction in measured circumference of pole to compensate for enclosed pocket

Diameter of pocket (inches)	3			4			5		
Minimum thickness of shell (inches)	1	2	3	1	2	3	1	2	3
Measured circumference of pole (inches)	Reduction in circumference (inches)								
30 to 40	2	1	1	3	1	1	4	2	1
40 to 50	2	1	1	3	2	1	4	3	1
50 to 60	2	2	1	3	3	1	4	3	1

measure the original (SF 4) circumference of the pole; then refer to [table 3](#) to obtain the circumference. Check the original end reduced circumferences against table 1.

To determine the shell thickness, bore four holes (preferably 5/16- or 3/8-inch diameter), 90° apart; measure the shell thickness at each hole, add, end divide by 4. No transmission pole shall remain in service with a shell thickness less than 3 inches.

**5.3.4. Enclosed pocket.** - An enclosed pocket is an off center void as shown in table 4, and its diameter should be measured by boring holes as described in [section 5.3.3](#). Using the minimum thickness of the shell, refer to table 4 for the reduction in circumference. After calculating the reduced circumference, check the original end reduced circumferences against [table 1](#).

For more than one enclosed pocket, determine the reduction for each pocket separately and add them to determine the total reduction.

## VI. APPROVED TREATMENTS

### 6.1 .DECAYMAINTENANCE.-

**6.1.1. Groundline treatment.** - Supplemental field treatments are not a substitute for thorough original treatment by the pole supplier. Nevertheless, all treated poles sooner or later lose resistance to decay, and groundline treatment provides an economical extension of their physical life. Experience has shown that groundline decay can be postponed almost indefinitely by periodic inspection and maintenance.

Groundline treatment is recommended under the following conditions:

(1) Whenever a pole is excavated during an inspection, and the pole is sound or decay is not so far advanced that the pole must be replaced.

(2) Whenever a pole over 5 years old is reset.

(3) Whenever a used pole is installed as a replacement.

Various products and methods are now promoted for the groundline treatment of standing poles. Some solutions are available for pouring on the outer surface of the pole for groundline treatment, but the use of a preservative paste or grease is recommended. Accepted pastes or greases containing toxic fungi-killing agents, including a high concentration of sodium fluoride or pentachlorophenol are:

a. Pento-creto paste (heavy-duty type), manufactured by Androc Chemical Co., Minneapolis, Minn.

b. Osmoplastic, manufactured by Osmose Wood Preserving Co. of American, Inc., Buffalo, N.Y.

c. Pole Preservative PasteT-X, manufactured by Wood-Treating Chemicals Co., ST. Louis, Mo.

d. POL-NU or TIMPREG, manufactured by Chapman Chemical Co., Memphis, Tenn.

After excavation and inspection below groundline have been completed, use a blunt tool to scrap away all external decay found on the pole. Take measurements to determine whether the pole meets the minimum permissible circumference in accordance with [tables 1, 2, 3, and 4](#). If the circumference of the pole meets the requirements, clean the pole surface with a wire brush. Remove all debris from the excavated area. Cover the surface of the pole from 3 inches below the decayed section up to at least 6 inches above the ground level with an acceptable grease or paste applied according to instructions furnished for the specific preservative used. Then wrap the treated section of the pole with two layers of Kraft laminated paper or a suitable substitute. Use

staples or masking tape to hold the wrapping in place. Backfill and tamp well.

Groundline treatments should be given during the summer months. Help is then more readily available; the preservative need not be heated; digging is easier, and the pole is drier.

This bulletin emphasizes the desirability of inspection and groundline treatment before decay is well advanced into the pole at groundline. When groundline decay is discovered too late, the pole must be stubbed or replaced. Stubbing can frequently be done at one-third to one-half the cost of replacement, particularly when replacement would require considerable transfer work. Of course, the upper portion of any pole to be stubbed must be sound and in generally good condition. When stubbing is decided upon, figure 10 should be used as a guide. The strength of a stub must equal the strength required for a new pole.

**6.1.2. Above-ground treatment.** - The above-ground portion of a pole is not subjected to the same conditions that promote decay at groundline. Nevertheless, decay above ground (often referred to as "shell rot") will, in time, develop in ail poles. In recent years there has been increased use of spray, flow-on, or brush treatments to the upper portion of poles, especially butt-treated cedar transmission poles.

The treatment should be applied before surface decay starts or while it is in the early stages. It is applied only once in the life of a pole. Such treatments may be considered in the following cases:

- (1) In butt-treated cedar transmission poles 15 to 20 years old.
- (2) In butt-treated or full-length-treated poles of other species, but mainly on transmission lines in which poles are expensive to replace and where such poles are protected from groundline decay by repeated groundline treatment.

There are companies with the required equipment who specialize in performing this type of treatment by contract. The work

should be closely supervised; because to be effective, the penetration and absorption of the preservative must be the maximum possible. The recommended preservative is a 10 percent solution of penta in a light petroleum carrier, or equivalent. The pole surface should be dry, with the pole moisture content below 30 percent as determined using a moisture meter.

A Reclamation employee should first spot check the poles from the ground and mark poles that are deemed suitable for the treatment, excluding those defective for any reason. The contractor should make a second inspection of the marked poles by climbing them and excluding any poles in which top decay is too far advanced.

In addition to determining that the right poles are treated, a Reclamation employee should verify the amounts of preservative used, see that critical points are carefully treated, obtain samples of the preservative for analysis, and generally observe that all details of the treatment are carried out as agreed. Detailed records should be made and retained in permanent files.

The treatment is usually applied through a flexible hose under 5 to 8 pounds per square inch (lbs/in<sup>2</sup>) of pressure from a tank truck. Treatment starts at the top of the pole with the preservative flowing thoroughly to ail surfaces. Immediately after the first treatment, a second application of preservative should be applied to the top 10 feet of the pole to assure maximum absorption in the upper section and at attachment points.

Safety precautions must be carefully observed, especially when applying this treatment to poles supporting energized electric lines. Caution should also be used to avoid damage to freshly treated poles by grass fires.



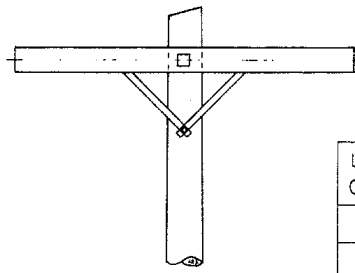

LENGTH OF POLE	A	MIN. TOTAL LENGTH OF STUB
30-0	5-0	10-6
35-0	5-0	11-0
40-0	5-6	11-6
45-0	6-0	12-6
50-0	6-0	13-0

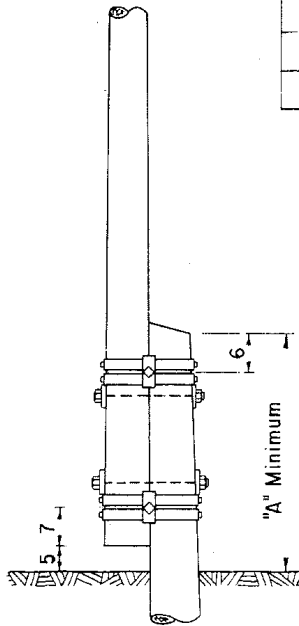

TYPE A

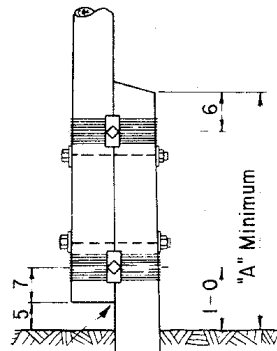

Do not bank  
TYPE B

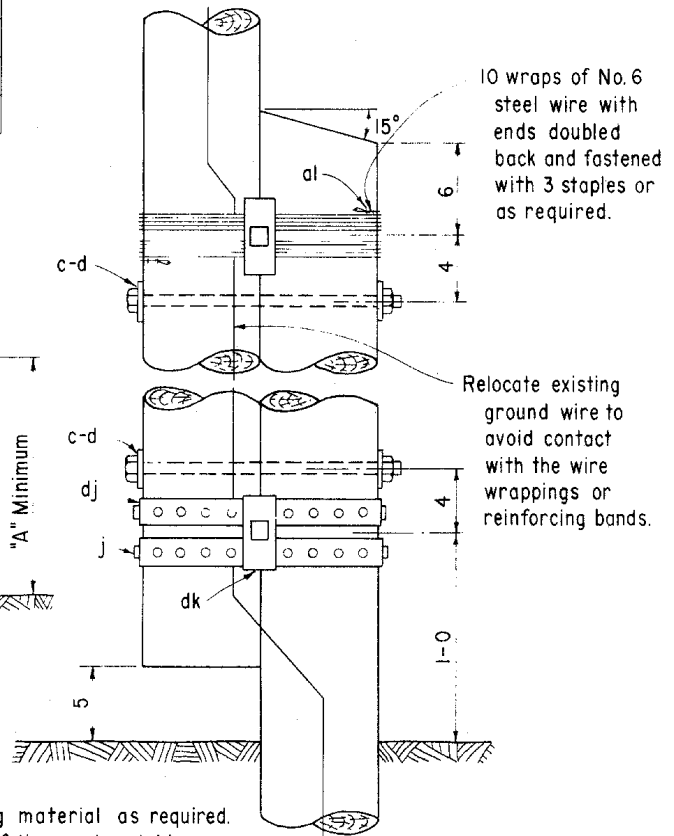
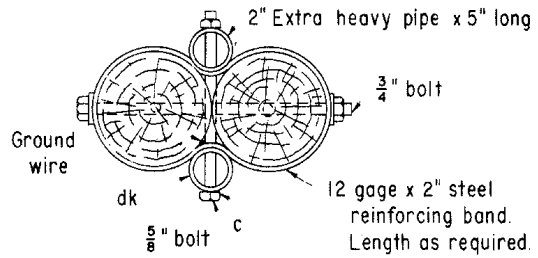

NOTES:

Use either wire wrapping or reinforcing band for stubbing material as required.  
Position stub at side of pole (At right angle to direction of line and outside of angle.)

ITEM	NO. REQ'D	MATERIAL	ITEM	NO. REQ'D	MATERIAL
c	2	Bolt, machine, $\frac{3}{4}$ " x required length			Wire, No. 6 galvanized steel, as required
c	2	Bolt, machine, $\frac{5}{8}$ " x required length	al		Staples, as required
d	4	Washer, $2\frac{1}{4}$ " x $2\frac{1}{4}$ " x $\frac{3}{16}$ ", $\frac{13}{16}$ " hole			
j	4	Screw, lag, $\frac{1}{2}$ " x 4"			
dj	4	Band, reinforcing, 12 gage x 2" x req'd. length			
dk	4	Pipe spacer, 2" extra heavy x 5" long			

## 6.2. OTHER MAINTENANCE.-

**6.2.1. Woodpecker damage.** - Woodpecker damage is another problem requiring attention in some localities. Many ideas have been tried to outwit these birds, but nothing has been entirely successful. Two points are worth keeping in mind:

(1) There has been a tendency to exaggerate the damage done by woodpeckers. The ordinary breaking point is near the ground. Above the midsection, where most woodpecker attacks occur, tests have shown that 25 percent of the wood can be removed without serious loss of strength. With consideration to wind loading, woodpecker holes are less damaging on either face than on the side of the pole.

(2) Woodpecker holes often expose untreated wood to moisture and the spores of fungi, with resulting decay that weakens the pole far more than the holes themselves.

It appears that a woodpecker selects a pole only by chance, and that the first hole invites further attack by other woodpeckers. Appendix C contains a method of repairing woodpecker damage to wood poles.

**6.2.2. Termite and ant damage.** - Termite and ant damage can be a problem in many areas. Ground-dwelling termites can be controlled by the same measures taken to prevent decay-good preservative treatment. Black and brown carpenter ants can be a serious problem, especially in cedar or injury and construct galleries that seriously weaken the pole near the groundline. Unlike termites, they do not feed upon the wood. They may be effectively destroyed by injecting about 1 pint of creosote into the inter-connected galleries. An ordinary grease gun, fitted with a suit-

able nozzle, can be used to inject the creosote into two or three holes bored to connect with the galleries. Occasionally, ground-dwelling termites are found in poles otherwise sound, and they may be destroyed in the same manner.

**6.2.3. Fire damage.** - Fire damage can make poles useless. Extreme care should be used in burning rubbish or brush along rights-of-way where treated poles are spotted. After poles are set in the ground, the immediate area should be cleared of weeds. Freshly treated poles can often be easily ignited; after a few months in service, treated poles become more fire resistant. Where hot grass fires occur annually, and particularly if butt-treated poles are used in such areas, the grass around poles should be eliminated in the spring with commercial weedkillers. Fire-retardant coatings are available for application to poles. Aluminum sheets tacked around pole bases have also proved effective, and are particularly suitable on farmed land. When a chemical weedkiller is to be used, a soil-sterilant, water-soluble type that will keep weeds down for a 3-year period is recommended. (See FIST Volume 4 - 8, Herbicides Available for Treating Soil for Total Vegetation Control.)

## VII. REPORTING

**7.1. FORMS.** Various forms have been developed for recordkeeping concerning pole inspection and maintenance. Some utilities maintain a record for each pole on a form that provides spaces for keeping track of inspections and their results. A sample ADP form developed by BPA (Bonneville Power Administration) is displayed in [figure 11](#) with instructions in [figure 12](#). This particular form could be acquired from BPA or a similar form could be developed if a computerized record of wood pole inspection and maintenance is desired.

U. S. Department of the Interior - Bonneville Power Administration  
**WOOD POLE INSPECTION and MAINTENANCE REPORT**

Instructions on reverse side.

LINE	DATE					INSPECTOR					REMARKS					
	ADNO	6	9	1	5	C	K	1	5	YEAR	CONDITION	YEAR	REPLACED	YEAR	INSPECTED	
10	12 13					15 16 17					DO NOT KEY PUNCH					
	15 16 17					21 79										
<b>FOR POLE REPLACEMENT ONLY</b>																
MILE	Z 0 1					MILE					A					
MILE	WORK ORDER					NO. IN REPLACED					POLE DATA					
10	12	13	15	16	18	20	21	22	24	25	26	27	28	29	30	31
COMMENTS																
10	12	13	15	16	18	20	21	22	24	25	26	27	28	29	30	31

Figure 11.

**INSTRUCTIONS FOR USING BPA 1007**

General - Use the top portion of this form to report wood pole inspection and maintenance activities. Use the bottom portion (FOR POLE REPLACEMENT ONLY) for reporting the replacement of wood poles. Report current activities only. Leave all other spaces blank. Write carefully and legibly. Keep figures within their proper space. Do not use ditto marks. Fill in the columns following the instructions listed below.

SUBJECT		COLUMN	INSTRUCTIONS	LOWER PORTION OF FORM FOR POLE REPLACEMENT ONLY	
SUBJECT		COLUMN	INSTRUCTIONS	SUBJECT	COLUMN
ADNO	6-9	Enter correct code from your current Area list.	Z01	1-5	Leave blank
Mile	10-12	Enter mile number. Justify right.	Mile	10-12	Enter mile number. Justify right.
Structure No.	13-14	Enter structure number. Justify right.	Structure No.	13-14	Enter structure number. Justify right.
Pole letter	15	Enter pole letter. Use "A" for single pole structures. Use "G," "H," "J," or "K" for guy stubs (up to four per structure).	Pole letter	15	Enter pole letter. Use "A" for single pole structures. Use "G," "H," "J," or "K" for guy stubs (up to four per structure).
B 01	1-5	Leave blank.	Work order	16-20	Enter work order number. Pole replacement is being charged to.
Sonic test	16	Enter "G" for a good sonic test. Enter "B" when sonic test indicates decay pockets. Leave blank when no sonic test is made.	P/E	21	Enter "P" if programmed. Enter "E" if emergency replacement.
Pole qts drilled	17-20	Enter results found in the col. indicating the pole qtr drilled. Leave undrilled qtrs blank. Enter "9" for all good wood. "8" for small heart rot with 8 inches or more of good wood. Enter actual inches (no fractions) for less than 8 inches of good wood.	Cause	22-24	Enter one of the following alphabetic letters corresponding to the cause. Make three entries in order of importance beginning with Column 22. Leave Column 23 and 24 blank when no secondary causes are apparent.
Insect damage	21	Enter insect damage as follows: G = Good, normal no problem. F = Fair, some deterioration but serviceable or repairable. B = Bad, schedule for replacement.			
Type	22	Enter "A" for Ants, "B" for Golden Buprestid, or "T" Termites.			
Yr inspected	79-80	Enter last two digits of year butt inspection was made. Justify right.			
B 02	1-5	Leave blank.			
POLE TOP HEART ROT					
Diameter	16	Enter "O" for sound top. Enter average diameter of hole in inches.	No. Ins replaced	25-26	Enter number of insulators replaced. Justify right.
Depth	17-18	Enter "O" in each col. for sound top. Enter average depth of hole in inches. Justify right.	X-arm Y or N	27	Enter "Y" when crossarm replaced. Justify right.
Shell rot	19	Enter shell rot condition as follows: G = Good, normal, no problem. F = Fair, some deterioration but not hazardous. B = Bad, schedule for replacement.	Month	28-29	Using numeric system enter month pole replaced. Justify right.
Shell crk.	20	Enter cracks, splits, or breaks in pole as follows: G = Good, normal no problem. F = Fair, still serviceable or repairable. B = Bad, schedule for replacement.	Day	Blank	Enter day of month. Justify right.
Bird or animal	21	Same as shell crk.	Year	30-31	Enter last two digits of year pole replaced.
Yr inspected	79-80	Enter last two digits of year climbing inspection was made.	A	1-5	Leave blank.
C	1-5	Leave blank.	Str design	16-19	Enter last two digits of year pole replaced.
Ground line	16-17				
Above Grnd Pres Trt	18-19		Str type	20-23	Enter new pole length. Justify right.
Pole top repair brackets	20-21		Length	24-26	Enter new pole length. Justify right.
Pole top preservative	22-23		Circumference	27-28	Enter circumference (inches). Justify right.
Vapom	24-25		Kind	29	Enter the new pole species using the following code: C = Cedar, butt treated E = Fir, celloan treated F = Fir, full length treated L = Larch or tamarack P = Fir, full length treated X = Special, few of a kind D = Fir, full length treated thru bored.
CROSSARM			Year	30-31	Enter last two digits of year pole replaced.
K	1-5	Leave blank.	X	1-5	Leave blank
Year replaced	16-17	Enter last two digits of year crossarm was replaced.	Comments	16-61	Enter any comment you desire to become a part of the wood pole history.
Condition	18	Enter crossarm condition for pole "A" only. Same as for insect damage.			
Year inspected	79-80	Enter last two digits of year crossarm was inspected			
Remarks	None	Enter special notes			

Figure 12.

## APPENDIX A

### PROTECTING WOOD POLES WITH VAPAM (POLE GAS)

**A-1. INTRODUCTION.**-This appendix covers a method of treating Douglas fir, western red cedar, ponderosa and southern pine, and larch utility poles to arrest and prevent internal wood decay and to destroy insects such as termites, carpenter ants, and golden buprestids. This method utilizes an agricultural fumigant, sodium N-methyldithiocarbamate, known under the trade name Vapam, also identified as pole gas, that effectively sterilizes the poles in the section treated. In addition to rapid sterilization of the wood, a fungi-toxic residual is deposited in the cells of the wood from the gas phase. This residual is effective for an indefinite period since chemical analysis shows the residue to be principally elemental sulfur.

**A-2. TREATMENT.**-Use Vapam fumigant in wood poles at the time of groundline bore test inspection and as a supplemental groundline treatment. Schedule poles known to have internal decay or that have white wood showing near groundline for treatment before they have decayed to the point where replacing them is necessary.

#### **A-3. EQUIPMENT AND MATERIALS.-**

- (1) A 9/16-inch wood auger.
- (2) Vapam in 1-pint bottles.
- (3) Treated wood filler plugs (5/8 by 6 inches).
- (4.) Safety goggles.

#### **A-4. PROCEDURE.-**

- (1) If the pole is inspected with a sonic pole tester and no low readings are recorded and no evidence of wood-destroying insects is noticed, do not bore that pole and, hence, do not use the Vapam.
- (2) In poles with either decay pockets or insects, bore a hole in each quarter at groundline and one hole 2 feet above groundline, preferably above the decay pocket.

(3) Inject equal amounts of Vapam into all the holes, a total of 1 pint per hole or the amount it will hold (fig. A-1).

(4) Plug holes with treated plugs. Wear safety goggles to prevent any of the liquid Vapam from splashing into the eyes.

(5) Dispose of empty Vapam containers. DO NOT transport the empty containers in a closed vehicle.

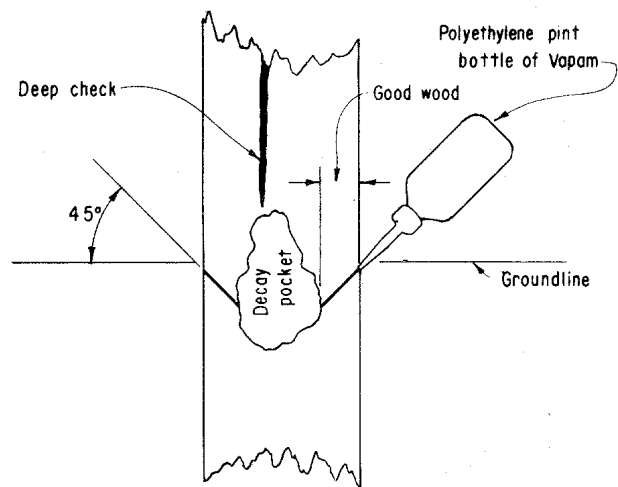

Figure A-1. Applying Vapam treatment.

(6) Carry the bottles of Vapam in sturdy cartons in pickup-type vehicles external to the passenger compartment.

**A-5. SAFETY.**-Vapam is a rather safe material since its external and internal toxicity can be considered low; and it would be nearly impossible to accidentally take in or expose oneself to a hazardous dosage. However, Vapam's irritating quality, which is similar to that of tear gas, makes the use of goggles mandatory and the use of rubber gloves highly desirable. On the other hand, however, the foul odor of this material will

readily manifest its presence so that necessary corrective actions can be taken readily and safely. To protect workmen who may be unusually sensitive to Vapam, each crew should have a chemical respirator at hand when using Vapam. As any other active chemical, Vapam should be used consciously and with respect.

Poles near residences or other locations where children or the public may come in contact with the treated pole shall not be treated with Vapam or any other toxic material.

## APPENDIX B

### MANUFACTURERS, PRODUCT NAMES, AND INGREDIENTS OF TOXIC FUNGI-KILLING PRODUCTS FOR GROUNDLINE TREATMENT OF STANDING WOOD POLES

Chapmen Chemical Company  
P.O. Box 9158  
416 E. Brooks Road  
Memphis, TN 38109  
(901)398-6261

"POL-NU"		
Active ingredients:	Pentachlorophenol	9.16% *
	Other chlorinated phenols	1.07 *
	Aromatic petroleum derivative solvents	81.34
Inert ingredients:		<u>8.43</u>
		100.00%

---

\* Equivalent to 10.66 percent pentachlorophenol, technical, as defined by Federal Specification TT-W-570a.

"TIMPREG"		
Active ingredients:	Pentachlorophenol	9.21% *
	Other chlorinated phenols	1.07 *
	Creosote	15.00
	Sodium Fluoride	15.00
	Aromatic petroleum derivative solvents	51.30
Inert ingredients:		<u>8.42</u>
		100.00%

---

\*Equivalent to 10.7 percent pentachlorophenol, technical, as defined by Federal Specification TT-W-570a.

Osrose Wood Preserving Company, Inc.  
980 Ellicott Street  
Buffalo, NY 14209  
(716)882-5905

"OSMOPLASTIC" (used with OsmoShield Polyethylene Moisture Barrier)		
Active Ingredients:	Sodium Fluoride	45.8%
	Dinitrophenol	3.5
	Potassium bichromate	2.5
	Pentachlorophenol	2.2
	Creosote (carrier plus thickeners)	41.0
Inert ingredients:		<u>5.0</u>
		100.0%

"OSMOPLASTIC B"		
Active ingredients:	Sodium borate	15.0%
	Pentachlorophenol	10.0
	Creosote	15.0
Inert ingredients:	(carrier plus thickener)	<u>60.0</u>
		100.0%

Osmose Wood Preserving Company, Inc. (Cont.)

"OSMOPLASTICF"		
Active ingredients:	Sodium fluoride	20.0%
	Pentachlorophenol	10.0
	Creosote	15.0
Inert ingredients:	(carrier plus thickener)	<u>55.0</u>
		100.0%

Wood Treating Chemicals  
 Division of Koppers Co., Inc.  
 5137 S.W. Avenue  
 St. Louis, MO 63110  
 (314)772-2200

"POLE-TOX" (made for asplundh) or "TRITOX"		40.0%
Active ingredients:	Sodium fluoride	3.0
	Potassium dicaromate	10.0
	Pentachlorophenol	35.0
	Creosote	<u>12.0</u>
Inert ingredients:		100.0%

"POLE-LIFE"		
Active ingredients:	Sodium fluoride	15.0%
	Pentachlorophenol	10.0
	Creosote	15.0
Inert ingredients:	(carrier plus thickener)	<u>60.0</u>
		100.0%

Adams Engineering, Inc.  
 4805 University Ave N.E.  
 Minneapolis, MN 55421

Intermountain Chemical and Supply Company (Western distributor)  
 P.O. Box 42  
 Fort Collins, CO 80522  
 (303) 482-6553

"PATOX" (impregnated glass fiber bandage)		
Active ingredients:	Sodium fluoride	37.9%
	Potassium dichromate	12.6
	Pentachlorophenol	10.0
	Creosote	11.0
Inert ingredients:		<u>28.5</u>
		100.0%



## APPENDIX C

### WOOD POLE WOODPECKER DAMAGE REPAIR

**C-1. INTRODUCTION.**-This appendix covers a method of repairing wood pole damage caused by woodpeckers thereby eliminating the climbing hazard, potential decay points, costly pole replacement, and regaining structural strength.

**C-2. MATERIAL.**-Excellent results have been obtained using the Semco epoxy compound to fill holes in wood poles. Adhesion to wood fiber was very good even where moisture was present, as the heat generated by the epoxy drives the moisture out and vaporizes it, as witnessed during trial application at the Bonneville Power Administration's Ross Laboratory. Texture of the material after curing was about the same as a knot and will support a lineman's climber to a better degree than a knot. The material can also be worked with standard tools such as drill bits, axe, chain saw, etc., with no damage to the tool. The material is also useful in blocking around cables to prevent rodent access into control buildings from cable trenches. In order to obtain the desired results, it is very important that the manufacturer's mixing instructions be followed closely. Failing to do so will give undesirable results.

**C-3. PROCEDURE.**-Have an adequate supply of material on hand to fill hole until excess starts to ooze out. Material warmed to room temperature is best for mixing, applying, and curing.

(1) Cover hole opening with cardboard and staple with stapling gun at upper end of hole to be filled.

(2) Mix epoxy according to instructions and squeeze contents into hole until excess oozes out. This assures a firm bond to wood and completely fills the

cavity when expansion from curing occurs.

(3) Most curing and expansion occurs within 10 minutes and cardboard can be removed and excess material readily chipped off.

Excess material that will not go into hole can be used to fill cracks or other voids.

#### **C-4. SAFETY PRECAUTIONS.-**

(1) Avoid direct skin contact by using disposable polyethylene protective gloves. Skin or barrier creams are not recommended.

(2) Avoid breathing vapors; especially when working in a confined area.

(3) Do not burn or heat to decomposition because toxic fumes (amines, isocyanates) may be emitted.

(4) Wear eye protection during all applications.

#### **C-5. FIRST AID PROCEDURES.-**

(1) Skin- Wash thoroughly with soap and water.

(2) Eyes - Flush immediately with plenty of water; see a physician.

(3) Inhalation - If used in a confined area, remove person to fresh air.

**C.6.DISTRIBUTORS.-PR-861WoodPatch/Semkits**

SEMCO  
5454 San Fernando Road  
Glendale CA 91209  
Phone (213) 247-7140

3623SixthAvenue, S.  
Seattle WA 98134  
Phone (206) 682-6570

SEATTLE OFFICE

Semco Midwest  
463 West Wrightwood  
Elmhurst IL 60126  
Phone (312) 530-2100

CHICAGO OFFICE

2353 Henderson Mill Road N.E. #1  
Atlanta GA 30345  
Phone (404) 938-9746

ATLANTA OFFICE

410 Jersey Avenue  
Gloucester City NJ  
Phone (609) 456-5700

GLOUCESTER OFFICE