

NATIONAL WEATHER SERVICE MANUAL 10-1401

June 2, 2010

Operations and Services

Upper Air Program NWSPD 10-14

Rawinsonde Observations

NOTICE: This publication is available at: <http://www.nws.noaa.gov/directives/>.

OPR: OS7 (S. Marsh)

Certified by: W/OS7 (K. Schrab)

Type of Issuance: Routine

SUMMARY OF REVISIONS: This manual supersedes NWSM 10-1401, “Rawinsonde Operations,” dated May 23, 2007. Changes include:

1. Updated references to RRS Workstation User Guide version of January, 2009.
2. Appendix A. Changed references to Chapter 13 of RRS User’s Guide, to Chapter 11.
3. Appendix B. Updated portions of Section 1 to reflect RRS deployments.
4. Appendix C. References to High Modulus Balloons were deleted.
5. Appendix D. Added sentence about reporting defective parachutes to WSH in Section 2.3.
6. Appendix E. Updated Surface Observation at release time; Surface Observation equipment failure; pre-release, in-flight, and after flight tables for RRS; GPS Radiosonde Launches.
7. Appendix F. Changed time on Table-1 from H+2 hours 30 minutes, to read H+2 hours. Corrected description and examples for dd and fff (page F-12).
8. Appendix H. Updated instructions for contacting SDM.
9. Appendix I. Corrected WS Forms 10-1304-1 to WS Forms 10-13-1. Added upper air website link for submitting forms. Updated instructions for second and third releases, and for missed and special observations.
10. Appendix J. Updated references to WS Form B-33, NWS Instructions, RRS User Guide, and WS Form 10-13-1. New instruction for required software at station; minimum supplies; handling of rejected radiosondes, balloons, and parachutes..
11. Appendix K. Page K-1, changed the reference to Section VII of WS Form B-48, to read Sections III and IV. In Section 4.1.2.h added sentence about not rolling, storing or dragging cylinders.
12. Appendix L. Web address for EHB#9 was updated.
13. Appendix M. Administrative responsibilities and timetables updated.
14. Appendix O. Deleted outdated Table O-1.

Signed 05/19/10
David B. Caldwell Date
Director, Office of Climate,
Water, and Weather Services

RAWINSONDE OBSERVATIONS

<u>Table of Contents:</u>	<u>Page</u>
1. Purpose and Scope	4
2. Documentation of Station Upper-Air Program and Facilities	4
3. Observational Procedures	4
3.1 Times of Observations	4
3.2 Transmission of Observation	5
3.3 Recording and Preserving Observations.....	5
4. Official National Weather Service (NWS) Stations	5
5. Unforeseen Requirements.....	5
6. Certification of Observers.....	5
7. Office Responsibilities.....	5
7.1 Upper-Air Station	5
7.2 Regional Headquarters.....	5
7.3 Weather Service Headquarters.....	6

Appendices

A. Radiosonde Familiarization	A-1
B. Tracking Systems Familiarization.....	B-1
C. Balloon Familiarization	C-1
D. Pre-Observation Preparations	D-1
E. Launching Procedures.....	E-1
F. Observation Procedures and Data Transmission	F-1
G. Terminating and Archiving the Observation	G-1
H. Quality Control of Data	H-1
I. Completion of Documentation (Forms).....	I-1
J. Station Management	J-1
K. Station Safety	K-1
L. Radiosonde Surface Observing Instrument System (RSOIS).....	L-1
M. Special Observations.....	M-1
N. Radiosonde Preparation	N-1
O. Rules for Disposal of Radiosonde Battery Activation in Water	O-1
P. Acronyms and Abbreviations	P-1

1. Purpose and Scope. Since the late 1930's the National Weather Service (NWS) has measured vertical profiles of pressure, temperature, relative humidity, and wind velocity through the use of balloon-borne radiosondes. This manual defines upper-air operational requirements and procedures applicable to all NWS stations. These instructions cover those sites engaged in taking and reporting atmospheric observations with Vaisala Automatic Radio-Theodolite (ART) Radiosondes and the MicroART computer system as well as those sites using Global Positioning System (GPS) radiosondes with the Radiosonde Replacement System (RRS) tracking system.

All aspects of the rawinsonde observation are covered from preparing the radiosonde and balloon train to processing and disseminating upper-air data. Also provided are procedures for completing upper-air data forms and maintaining station upper-air equipment. Since operations at each upper-air station can vary, appendices to this manual have been included that may or may not pertain to each office. Within the appendices, paragraphs and sections may address the ART and RRS systems together.

This manual does not provide detailed procedures for taking upper-air observations with other Navigational Aid (NAVAID) rawinsondes or with Radio-Direction Finding (RDF) equipment other than the Ground Meteorological Device (GMD) or Weather Bureau Radiotheodolite (WBRT). Observers using other equipment should follow the manufacturers operating instructions.

2. Documentation of Station Upper-Air Program and Facilities. Each upper-air station is responsible for maintaining accurate information files pertaining to its upper-air program. The procedures and responsibilities for documentation of equipment, instrumentation, and observing programs are found in NDS 10-13.

3. Observational Procedures. The procedures and operational requirements defined in this manual apply to all NWS upper-air stations. These procedures have been written to ensure NWS compliance with the observational standards defined in Federal Meteorological Handbook 3 and the World Meteorological Organization (WMO) Code Manual 306 Volume I and II.

3.1 Times of Observations. Standard observations from all network stations will be made twice daily, at 0000 and 1200 Universal Time Code (UTC), unless extenuating and justifiable circumstances prevent it. Actual release times for the 00 and 12 UTC standard scheduled upper air observations should be as close as possible to H-60 minutes, where H is one of the standard times. The release time for a synoptic observation should not fall outside the period known as the release windows for RRS and ART. These time ranges are:

- a. RRS window is from H-60 to H+29.
- b. MicroART window is H-60 to H+59.

For all non-standard observation times, the release window, in regard to the record time of the observation, is from 30 minutes before to 29 minutes after the hour of the assigned observation time. Any release beyond the window will have the next synoptic hour assigned to it.

3.2 Transmission of Observation. The coded message containing data from the observation will be provided to the telecommunication system for dissemination to government agencies and other data users in as timely a manner as possible. The deadlines for transmitting the coded messages are provided in Appendix F, Table F-1.

3.3 Recording and Preserving Observations. An archive record of all synoptic rawinsonde observations will be made for submission to the National Climatic Data Center (NCDC). An archive record will also be made of unscheduled observations that are transmitted over telecommunications for use by the government or other data users. The requirements for recording and disseminating these records to the NCDC are described in Appendix I.

4. Official National Weather Service (NWS) Stations. The NWS participates in the WMO's World Weather Watch Program by maintaining and operating a network of rawinsonde stations in the contiguous U.S. (69 sites), Alaska Region (13), Caribbean (1), and (9) Pacific Region. This network of stations comprises approximately ten percent of the global rawinsonde network.

5. Unforeseen Requirements. No set of procedures can cover all possibilities that can occur in an operational setting. The observer uses judgment in adhering as closely as possible to this manual, to handle situations not adequately covered by specific instructions. If procedures in this manual require changes or clarification, suggest them through the site supervisor, who in turn should forward the suggestion to your Regional Headquarters (RH). If RH determines the suggestion is appropriate, the Region should forward the suggestion to Weather Service Headquarters (WSH) for possible inclusion into future manual or handbook revisions.

6. Certification of Observers. In order to take official upper-air observations, an observer is certified in accordance with NWSI 10-1304. The observer will pass a written examination administered by station management or delegated staff, with a minimum score of 80 percent. Each observer will pass an eye examination or show proof of visual acuity of 20/30 or better in at least one eye.

7. Office Responsibilities.

7.1 Upper-Air Station. Rawinsonde observations are essential for producing accurate weather forecasts and warnings. The data also serves other purposes (e.g., aviation operations). Therefore, each observer will ensure observations of the highest quality possible for dissemination. When there is reason to believe that the accuracy or validity of the upper-air data are questionable or erroneous, follow the procedures outlined in this manual and software user guides for handling such situations. If ground equipment is believed to be the source of the problem, the observer should notify the electronics technicians for corrective actions.

7.2 Regional Headquarters. RH offices will be responsible for overseeing the operations at each upper-air station in their Region. Specifically, they are responsible for the following activities:

- a. Provides assistance in identifying and correcting station problems and

coordinating such problems with WSH.

- b. Maintains upper-air station forms, containing station performance and logistical data for a minimum of two years.
- c. Prepares and disseminates quarterly reports of station performance. These reports should include information on average burst heights, failed observations, and second releases.
- d. Develops NWS Supplements related to observing procedures and guidelines.
- e. Conducts periodic station inspections to ensure compliance with the standards and procedures of this manual.
- f. Evaluates the upper-air examination and provides test results to the field sites.
- g. Assists WSH with field tests of new equipment, software, and observational procedures.

7.3 Weather Service Headquarters. WSH manages the upper-air network through the following activities:

- a. Procures balloons and radiosondes for upper-air stations and maintains pertinent logistical data.
- b. Develops and maintains documentation related to operational upper-air observations. This includes, Policy Directives, handbooks, manuals, training materials and software installation instructions.
- c. Maintains, makes, and tests necessary changes to upper-air software.
- d. Prepares reports on overall station and network performance.
- e. Develops specifications for all equipment, from balloons and radiosondes to ground tracking and data processing systems.
- f. Laboratory and field tests the operational performance of all equipment.
- g. Assists with Regional Office station inspections.
- h. Prepares and maintains the upper-air observer certification exams.

APPENDIX A – RADIOSONDE FAMILIARIZATION

<u>Table of Contents:</u>	<u>Page</u>
1. Introduction.....	A-1
2. Radiosonde Inspection.....	A-2
3. Radiosonde Components	A-2
3.1 Pressure Sensor (Capabilities and Limitations).....	A-3
3.2 Temperature Sensor	A-3
3.2.1 Vaisala	A-3
3.2.2 Lockheed Martin Sippican	A-3
3.2.3 Sensor Capabilities and Limitations	A-4
3.3 Relative Humidity Sensor.....	A-4
3.3.1 Vaisala	A-4
3.3.2 Lockheed Martin Sippican	A-5
3.3.3 Sensor Capabilities and Limitations	A-5
3.4 Radio Transmitter and Battery.....	A-6
3.4.1 Radio Transmitter	A-6
3.4.2 Battery.....	A-6

1. Introduction. The purpose of this appendix is to familiarize observers on the operation and handling of radiosondes and the NWS ground systems used to collect, process, and disseminate the upper-air data. NWS currently uses two types of RDF radiosondes: the Vaisala RS-80-57H and the Lockheed Martin Sippican B2. These radiosondes are tracked with an (WBRT or GMD) system. The NWS also is transitioning to GPS radiosondes with the RRS tracking system. The initial GPS radiosonde is the Lockheed Martin Sippican MkIIA. Each radiosonde manufacturer has prepared step-by-step instructions for preparing their radiosondes for the observation. The observers should follow these instructions and those provided in either Appendix N for the GPS radiosonde or instructions supplied in the shipping box for other radiosondes.

The radiosonde is a small, expendable instrument package that is suspended below a large balloon filled with hydrogen or helium gas (see Appendix C - Balloon Familiarization for more information on balloons used and their handling). As the radiosonde ascends, sensors on the radiosonde measure the pressure, temperature, and relative humidity (RH). These sensors are linked to a battery powered radio transmitter that sends the sensor measurements to a sensitive ground receiver at 1 to 2 second intervals. During the observation, the ground system tracks the position (i.e., angular bearing) of the radiosonde. This information is used to derive wind speed and direction aloft for the RDF tracking systems while the RRS tracking system uses GPS to determine wind speed and direction. A computer is used to process, encode, and disseminate the data.

The observation can last in excess of two hours. During this time, the radiosonde can rise over 30 Kilometers (km) and drift more than 250 km from the release point. During the observation, the radiosonde is exposed to temperatures as cold as -95° Celsius (C), RH values ranging from 0 to 100%, and air pressures only a few thousandths of what is found at the Earth's surface.

When the balloon has expanded beyond its elastic limit and bursts (up to 10 meters in diameter), a small parachute slows the descent of the radiosonde, minimizing the danger to people and property. About twenty percent of the approximately 75,000 radiosondes released by the NWS each year are found and returned for reconditioning. These reconditioned radiosondes are reused, saving the NWS the cost of a new instrument.

2. Radioonde Inspection. The observer will physically inspect the instrument before proceeding with an observation. If broken, missing, discolored, or misshapen components are detected, the instrument will be rejected and another instrument used. **DO NOT ATTEMPT TO REPAIR THE INSTRUMENT**. Section 3 provides additional information on what to look for when inspecting radiosonde components for defects.

3. Radioonde Components. Radiosondes are delivered from the National Logistics Supply Center (NLSC) to the upper-air station assembled and ready for an observation. The following components make up the radiosonde instrument:

- a. Pressure, temperature and RH sensors measure the environment as a function of changes in sensor electrical parameters such as resistance or capacitance.
- b. A radio transmitter for telemetering sensor measurements to ground receivers.
- c. A battery for powering the electronic components.
- d. GPS electronics for RRS.

All the electronics and some of the sensors are housed within a waterproof casing made of lightweight, durable materials. A mailing bag is included with the instrument so that it can be returned for reconditioning. Total instrument weight ranges from less than 250 grams (Vaisala) up to 500 grams (Lockheed Martin Sippican).

Within each box of RDF radiosondes, a floppy diskette is enclosed that contains calibration data for each radiosonde. The Lockheed Martin Sippican MkIIA GPS radiosonde does not require a calibration diskette. It transmits the calibration data during baseline. The calibration data applies numerical constants and other calibration factors to the raw pressure, temperature, and RH data to ensure sensor accuracy. Appendix A of the MicroART Training Guide provides procedures for loading the calibration data into the MicroART computer.

3.1 Pressure Sensor (Capabilities and Limitations). Both Vaisala and Lockheed Martin Sippican radiosondes use a capacitance aneroid cell to measure atmospheric pressure. The cell is a metallic, wafer-shaped capsule with a partial vacuum. As the pressure changes, the cell expands (decreasing pressure) or contracts (increasing pressure), changing the separation between two plates contained inside the capsule. The pressure is determined by measuring the changing electrical capacitance between the plates. There are no springs, arms, or contacts which was common in older pressure sensor designs.

On both radiosonde types, the pressure sensor is located within the instrument packaging and is not readily visible. Do not attempt to open the radiosonde to view the pressure sensor.

The capacitive aneroid typically has an accuracy of about 0.5 Hecto Pascals (hPa) (with decreasing accuracy aloft), and a measuring range from 1060 to 3 hPa. It has excellent response time to rapidly changing pressures (less than a second). The capsule can occasionally leak during an observation (usually above 15 km) causing abrupt changes in pressure and consequently unrealistically high ascension rates and heights. Moreover, during radiosonde preparation, the pressure sensor may provide out of tolerance readings and should be rejected. Procedures for handling these situations are provided in Chapter 8 of the MicroART and RRS Training Guide.

3.2 Temperature Sensor. Vaisala and Lockheed Martin Sippican radiosondes employ temperature sensors with different characteristics and limitations. Information on each type of sensor is provided below:

3.2.1 Vaisala. A "Thermocap" mounted on a flexible boom outside the radiosonde package is used to measure temperature. The thermo cap is a small bead that contains a capacitor that changes its electrical capacitance as a function of temperature. The sensor is coated with an aluminum coating to minimize solar and infra-red radiation.

If a thermocap is chipped, discolored, or damaged, reject the instrument and use another.

3.2.2 Lockheed Martin Sippican. Temperature is measured on the Lockheed Martin Sippican B2 radiosonde by the thermistor which is a small, thin rod comprised of baked clay and iron fillings. The sensor or "thermistor" measures temperature by the change in electrical resistance across the rod caused by changing temperature. A thermistor is mounted on the end of a flexible boom outside the radiosonde package.

If a thermistor is chipped, discolored, or damaged, do not attempt to repair or replace the sensor. The observer will reject the instrument and use another.

The Lockheed Martin Sippican Mark IIA GPS radiosonde uses a chip sensor at the end of the sensor boom. The only adjustment allowed is if the wire leads are bent, the operator may gently re-position the leads to their original configuration in accordance with the Lockheed Martin Sippican Mark IIA Radiosonde Preparation Instructions, (Appendix N).

3.2.3 Sensor Capabilities and Limitations. Vaisala and Lockheed Martin Sippican temperature sensors have an accuracy of about $\pm 0.3^{\circ}\text{C}$ in the troposphere and a very good response time to changing temperatures (generally less than 4 seconds). They are designed to operate over a temperature range of -90 to $+50^{\circ}\text{C}$.

If the thermocap or thermistor is exposed to wet conditions during an observation, the "wet bulb" effect may occur causing excessive cooling in the temperature measurements. Chapter 14 in the MicroART Training Guide and Chapter 13 in the RRS User Guide provide procedures for handling temperature observations when the wet bulb effect occurs and for other temperature data anomalies.

Both temperature sensors are affected to some extent by long-wave infrared radiation (IR) and shortwave ultraviolet solar radiation. The effect on the data is to cause the sensor to report a different measurement than is truly representative of the atmosphere.

During the daytime (i.e. when the sensor is exposed to sunshine), solar radiation is absorbed by the sensor causing it to read higher than the ambient temperature. The solar error varies with the solar elevation angle, with a minimum at low angles. At night, the solar effect is zero.

During day and night, the sensor radiates and absorbs long wave energy to and from its surroundings (i.e. space, ground, clouds, atmosphere, etc.) proportional to sensor temperature and the temperature of the surroundings. The long-wave error usually results in temperature readings lower than ambient but may lead to a positive error under some conditions.

The Lockheed Martin Sippican thermistor is coated with white paint to reduce the effects of solar and infra-red radiation, but it does not adequately lessen these affects at high altitudes. At altitudes above 16 km the temperature error can exceed 1°C . Observers **will not** correct or edit these data to correct for solar or the effects of infra-red radiation before dissemination. The National Center for Environmental Prediction (NCEP) and other users will apply the necessary corrections to the B2 radiosonde. This does not however, preclude the observer from editing or deleting temperature data that is obviously bad due to a sensor error.

The Lockheed Martin Sippican Mark IIA GPS radiosonde has a solar radiation correction applied by the RRS software. Vaisala coats its sensor with an aluminum coating and the temperature measurements are partially adjusted for radiation effects while being pre-processed in the MicroART Signal Processing Unit (SPU)-11 computer card. This does not however, preclude the observer from editing or deleting temperature data that is obviously bad due to a sensor error.

3.3 Relative Humidity Sensor. As with their temperature sensors, Vaisala and Lockheed Martin Sippican employ different technology for measuring RH. Both techniques are described in the next 3 sections:

3.3.1 Vaisala. The "Humicap" is located on the radiosonde boom beneath the thermo cap. This sensor measures RH as a function of changing electrical capacitance. Between the capacitor plates is a thin polymer film that expands or contracts with changing RH and changes the

electrical capacitance between the plates. The sensor is covered with a small, aluminum-coated plastic cap to shield it from solar radiation and precipitation.

Never remove the cap covering the RH sensor. If the cap is discolored, misshapen, or missing, reject the instrument and use another. If the cap has fallen off the humidity sensor, it may be placed on the sensor using a paper towel or cloth to avoid oil from the skin contaminating the sensor.

3.3.2 Lockheed Martin Sippican. Sippican employs a "hygristor" to measure RH. The hygristor is a rectangular strip of plastic which has been dipped in a liquid mixture of carbon particles and celluloid resin and then dried. The celluloid is sensitive to RH and expands or contracts with the amount of water vapor in the air. This fluctuation causes the distance between the carbon particles to vary and thus the electrical resistance across the strip.

To protect the sensor from precipitation and solar radiation, the hygristor is housed within a curved, black laminated (to reduce reflected solar radiation) duct that is built into the styrofoam radiosonde case.

The hygristor comes packed in a metallic container. During pre-observation procedures, it is removed from the container and installed into the duct. If the sensor is damaged (e.g., scratched during installation), misshapen, or discolored, select another sensor and enter the calibration data into the Radiosonde Data screen.

The RRS Mark IIa humidity sensor is enclosed in a metal cap attached to the side of the radiosonde. Refer to Appendix N for the proper procedures for handling the sensor. If the sensor is damaged (e.g., scratched during installation), misshapen, or discolored, reject the radiosonde.

3.3.3 Sensor Capabilities and Limitations. Both sensor types provide RH measurements from 0 to 100%. The accuracy of the sensors is about $\pm 5\%$ and the response time is in seconds. However, at temperatures below -30°C the response time of these sensors can exceed 2 minutes and their accuracy is not fully established.

Both RH sensor types (especially Vaisala) can provide erroneous readings if the sensor becomes coated with water or ice as it ascends through a cloud or precipitation. The result is RH readings that are biased too high. Refer to MicroART Chapter 14 and Chapter 11 in the RRS User's Guide for procedures on how to handle such data and other RH data anomalies.

Both sensors are affected by hysteresis. Hysteresis is characterized by the sensor's inability to correctly react to changing RH profiles such as when the radiosonde exits a cloud (i.e, the RH drops rapidly from near 100% RH to a much drier value). The RH error caused by hysteresis can exceed 10%. Chapter 14 of the MicroART Training Guide and Chapter 11 of the RRS User's Guide provide procedures for handling RH data resulting from this effect.

3.4 Radio Transmitter and Battery.

3.4.1 Radio Transmitter. The radio transmitter electronics used on all types of NWS radiosondes transmits data pulses that represent one of the radiosonde sensor measurements or an internal electrical reference. The data are transmitted in a repetitive cycle of pressure, temperature, RH, and reference measurements. This produces a sampling rate of about 1-2 seconds for each of the radiosonde sensors.

The transmitter power is 250-350 milliwatts with amplitude modulated frequency that can be manually tuned from 1675 to 1700 Megahertz (MHz). Authorized frequency channels for Lockheed Martin Sippican Mark IIA Radiosondes are 1676, 1678, 1680 and 1682. This power is sufficient for the ground system to receive the signal at distances exceeding 250 km.

The transmitter is housed inside the radiosonde casing to protect it from the elements. Do not open the casing to view the transmitter components. Follow the radiosonde preparation instructions in Appendix N for handling the RRS instrument and tuning it to the proper operating frequency. Refer to manufacturer for RDF Radiosondes.

3.4.2 Battery. For all types of NWS radiosondes, a water-activated battery is used for generating power to operate the radiosonde. The battery is not factory installed and is wrapped in foil or plastic. To activate the battery, remove from the battery package and soak it in water for the prescribed time. After activation, the battery is placed inside the radiosonde casing and will provide adequate power for up to 135 minutes. Follow manufacturer instructions.

APPENDIX B - TRACKING SYSTEMS FAMILIARIZATION

<u>Table of Contents:</u>	<u>Page</u>
1. Introduction	B-2
2. RDF System Description	B-3
2.1 RDF Subsystems	B-3
2.2 RDF Operational Limitations	B-8
2.3 Azimuth Convention - The Home Bearing	B-9
2.4 RDF System Control Positions	B-9
2.4.1 Master Control Console	B-9
2.4.2 Power Control Panel	B-10
2.4.3 Angle/Time Display Panel	B-10
2.4.4 Master Control Unit Panel	B-10
2.5 Remote Control Unit	B-15
3. NAVAID Network Stations	B-18
4. Global Positioning System (GPS)	B-19
4.1 Telemetry Receiving System (TRS)	B-19
4.1.1 Physical Description	B-20
4.1.2 Major Components	B-23
4.1.2.1 The Dish	B-23
4.1.2.2 The Receiver	B-23
4.1.2.3 Motor Drive Assemblies	B-23
4.1.2.4 Launch Area Box	B-23
4.1.2.4.1 Launch Area Control Display Unit	B-25
4.1.2.4.2 Launch Area Intercom	B-26
4.1.2.4.3 Launch Area Ringer	B-26
4.2 Overall System Description	B-26
4.3 Overall System Operation	B-27
4.3.1 Automatic Operation	B-27
4.3.2 Manual Operation	B-27
4.4 Tracking	B-28
4.4.1 Control Display Unit	B-28
4.4.2 User Interface	B-29
4.5 Climate Control	B-42
4.5.1 Environment	B-43
4.5.2 Circulation Fans	B-43
4.6 Power Supply	B-43
4.7 Communications	B-44

Figures	Page
B-1 NWS High-Bay Upper Air Shelter	B-4
B-2 NWS Low-Bay Upper Air Shelter	B-5
B-3 GMD Antenna/Pedestal Assembly (ART-1)	B-6
B-4 WBRT Antenna/Pedestal Assembly (ART-2)	B-7
B-5 The Antenna/Receiver Control Unit	B-8
B-6 Master Control Console (Full Rack Assembly)	B-9
B-7 Master Control Unit	B-10
B-8 Master Control Unit Close-Up	B-11
B-9 Angle/Time Display	B-14
B-10 Closed Remote Control Panel with Rain Cover	B-15
B-11 Open Remote Control Panel	B-16
B-12 TRS Installation Size	B-20
B-13 Antenna Unit	B-21
B-14 Launch Area Unit	B-24
B-15 CDU	B-25
B-16 CDU Keyboard	B-29
B-17 Diagram of TRS Power Control	B-44

Tables

B-1 Master Control Unit	B-11
B-2 Angle/Time Display Rack	B-14
B-3 Remote Control Panel	B-17
B-4 Antenna Unit Assemblies	B-22
B-5 Launch Area Unit Assemblies	B-24
B-6 Direction Controls	B-31
B-7 CDU Error Messages	B-41
B-8 Configuration Data from the DCE IDD	B-45

1. Introduction. The meteorological community utilizes several modes for radiosonde tracking. The NWS used RDF primarily because it had the least expensive types of radiosondes to meet operational requirements. The RDF relies on a number of mechanical and electrical parts which are kept precisely calibrated.

Some locations were not suited for the placement of an RDF system for several reasons. The relatively large size of the RDF requires attention to property availability, zoning ordinances, and support structure suitability. In addition, some locations are prone to interference in the RDF's band of operation. For these reasons, and others, some sites operate a smaller receiving system that relies on specially designed radiosondes. These tracking systems use radio-navigational techniques to track the radiosondes and obtain winds aloft information. Two NWS stations in the Eastern Region use the ground based U. S. Coast Guard Long Range Navigation (LORAN) Omni-directional transmitters. LORAN requires virtually no moving parts. Tracking is dependent on a LORAN radiosonde that determines its position through triangulation with at

least three LORAN ground stations.

Most of the RDF stations have been replaced by a tracking system using the GPS. Because of the difficulty in finding replacement parts for the RDF tracking system and its less precise wind tracking accuracy, the NWS decided to change to GPS based tracking. This method is becoming a cost effective means to independently observe the atmosphere in remote locations anywhere across the globe.

2. RDF System Description.

2.1 RDF Subsystems. The RDF system is housed within a 4.5 meter white fiberglass protective radome atop a balloon inflation building (Figures B-1 and B-2). The system is comprised of the receiving antenna, the radio-frequency (RF) assembly, and the receiver antenna control unit.

The primary purpose of the receiving antenna is to receive the radiosondes transmitted carrier frequency and the embedded data signal. The system is comprised of either a 2.3 or 3.0 meter diameter parabolic antenna, connecting shaft, secondary reflector, and dipole antenna (Figures B-3 and B-4). The main dish reflects signal energy to the secondary reflector, a .3 meter diameter cup that rotates on an offset axis. The rapid rotary motion of the secondary reflector gives a scan pattern that is best described as a narrow cone. Conical scanning enables the system to reliably track a radiosonde with an automatic gain control process. Radiosonde position can be measured accurately to within hundredths of a degree.

The RF assembly is housed on the backside of the tracking dish. The purpose of the RF assembly is to screen extraneous RF energy, and to selectively pass, filter, mix, and amplify the radiosonde carrier signal to create an intermediate frequency (IF) of 60 MHz. Next, the IF signal is routed to a second mixer and is amplified with information from the automatic gain control circuit. After an additional sequence of events, an IF signal of 10.7 MHz is produced. The IF signal is then processed by the receiver circuits within the receiver/antenna control unit (R/ACU), (Figure B-5).



Figure B-1 - NWS High-Bay Upper Air Shelter



Figure B-2 - NWS Low-Bay Upper Air Shelter



Figure B-3 - GMD Antenna/Pedestal Assembly (ART-1)

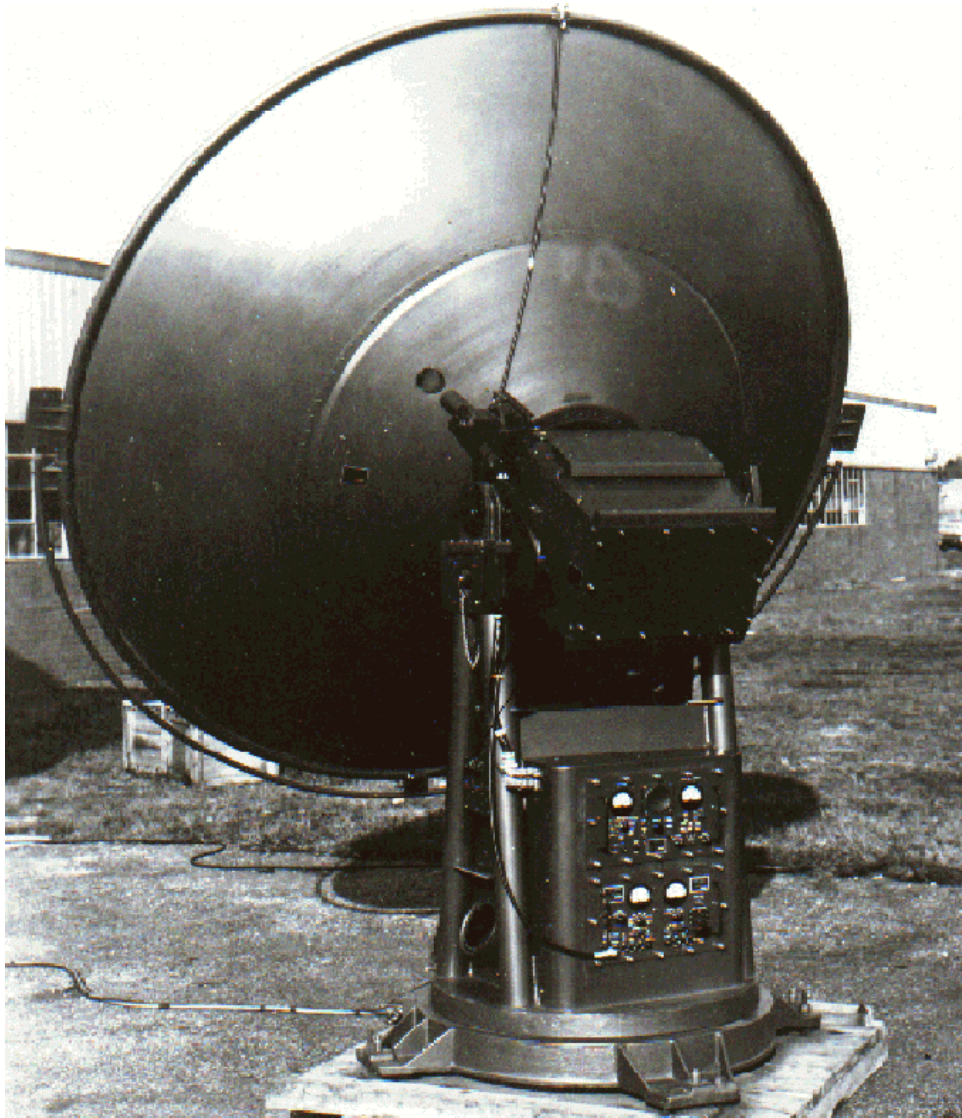

Figure B-4 - WBRT Antenna/Pedestal Assembly (ART-2)

The R/ACU is housed within a large box at the top of the antenna pedestal near the fulcrum of the parabolic tracking dish. In the R/ACU, two major signal processes occur. One is the extraction of the meteorological signal and the other is the creation of automatic gain control information for use in the RF assembly. The R/ACU also contains circuitry to digitize drive gear positional information, transmit commands to the drive gears, and to distribute status conditions (signal and position data) to the three control panels.

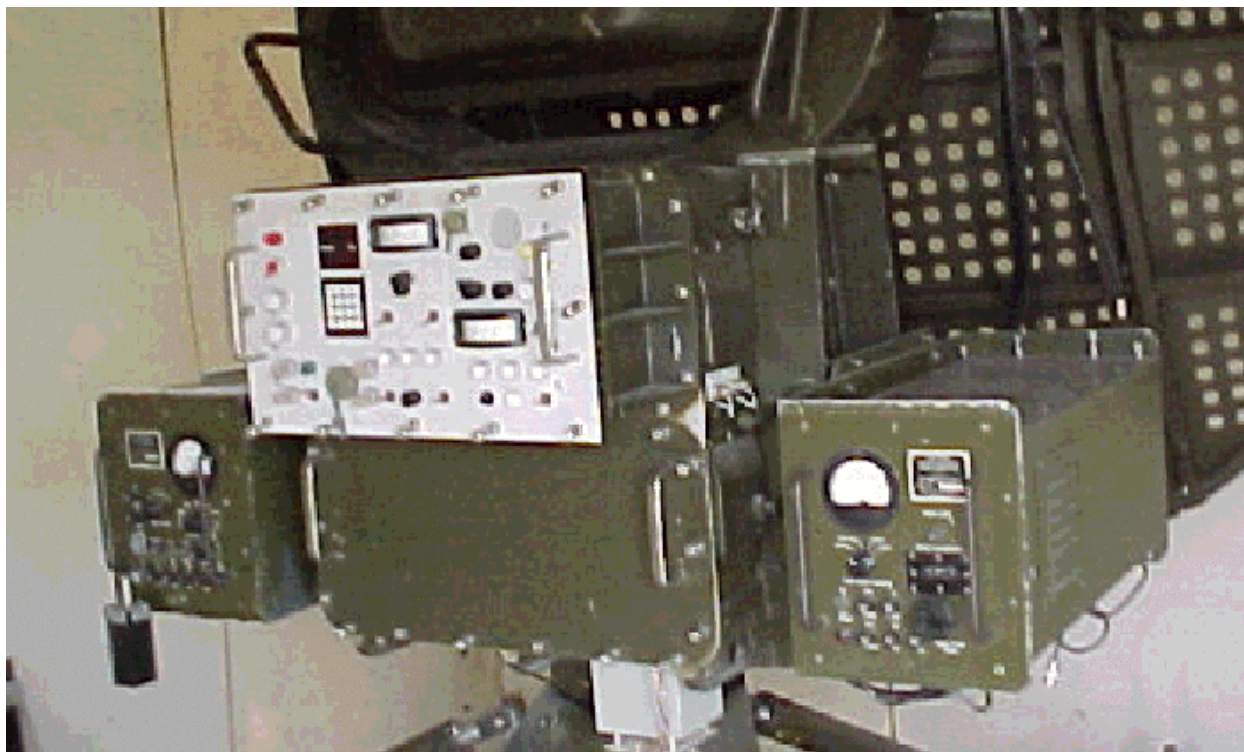

Figure B-5 - The Antenna/Receiver Control Unit

2.2 RDF Operational Limitations. The RDF system maintains proper signal lock automatically with the radiosonde until the radiosonde moves beyond the horizon or behind a zone of near-field objects. The RDF system might lose its lock on the signal if the received signal becomes seriously degraded from multipathing (splintering) about obstructions within the near or far ranges. Signal degradation can occur when the radiosonde moves within a six degree margin of the edge of obstructions. The RDF tracking lobe is six degrees.

Observers should recognize the RDF system's inability to distinguish between the transmitter's main lobe (true signal) from the radiosonde transmitter's ever present side-lobes. A side-lobe can give an azimuth discrepancy of as much as 30°. When the system gains a lock with a side-lobe, not only is the detected position in error, but the variable nature of the side-lobe's signal might lead to significant tracking disruptions, wind speed, direction errors and loss of data. To avoid tracking a side-lobe, check the remote control panel and master control unit for weak, jumpy, or intermittent signal strength. If detected, take immediate action to find a more stable and stronger signal indicating acquisition of the main signal lobe. Another indication would be an inexplicable change in azimuth bearing (e.g., 5° or more in 10 sec).

2.3 Azimuth Convention - The Home Bearing. Tracking systems identify radiosonde position with azimuth angles that are expressed as the compass bearing back toward the ground tracking station. For example, when winds are from due south throughout the atmosphere, the rawinsonde will fly northward, producing a 180° bearing. The Master Control Console displays 180° as the azimuth angle, or *home bearing*, of the radiosonde.

The RDF tracking hardware is maintained true with respect to its baseline orientation setting. For elevation angle accuracy, the pedestal (outrigger) equipment is leveled and set to 0.00 degrees. Similarly, the azimuth scale is set to 0.00 degrees based on true north. All components of the tracking system are maintained to give precision measured in the hundredths of a degree.



Figure B-6 - Master Control Console (Full Rack Assembly)

2.4 RDF System Control Positions.

2.4.1 Master Control Console. The RDF system operations are most often conducted in the office at the master control console. This master assembly (Figure B-6) is identified as the Servo Automatic Radio-Theodolite Data Control Assembly. It is comprised of the Power Control, Angle/Time Display, and the Master Control Unit Panels.

2.4.2 Power Control Panel. On the Data Control Assembly are two circuit breakers; the main breaker (red panel) is on left side and the service breaker (black panel) is on right side. The ON/OFF power button starts the RDF system.

2.4.3 Angle/Time Display Panel. An illuminated red digital Light Emitting Diode (LED) readout displays bearing angle, elevation angle, current time, and elapsed time information. With the power control panel on, the Angle/Time Display should always show the correct time and antenna position regardless of antenna or receiver operational status.

2.4.4 Master Control Unit Panel. The bottom panel of the master control console is the Master Control Unit (MCU). The leftmost side displays status information and gives control for powering the antenna/receiver unit. The MCU central section is a control point for the selection of tracking mode. From this section, MicroART data processing will be started with a push-button release switch (Item #13, Figure B-8). To the right side, are two meters that continually display received signal strength and frequency. Also in this section, is a control point for the selection of search mode and the adjustment of receiver's frequency.

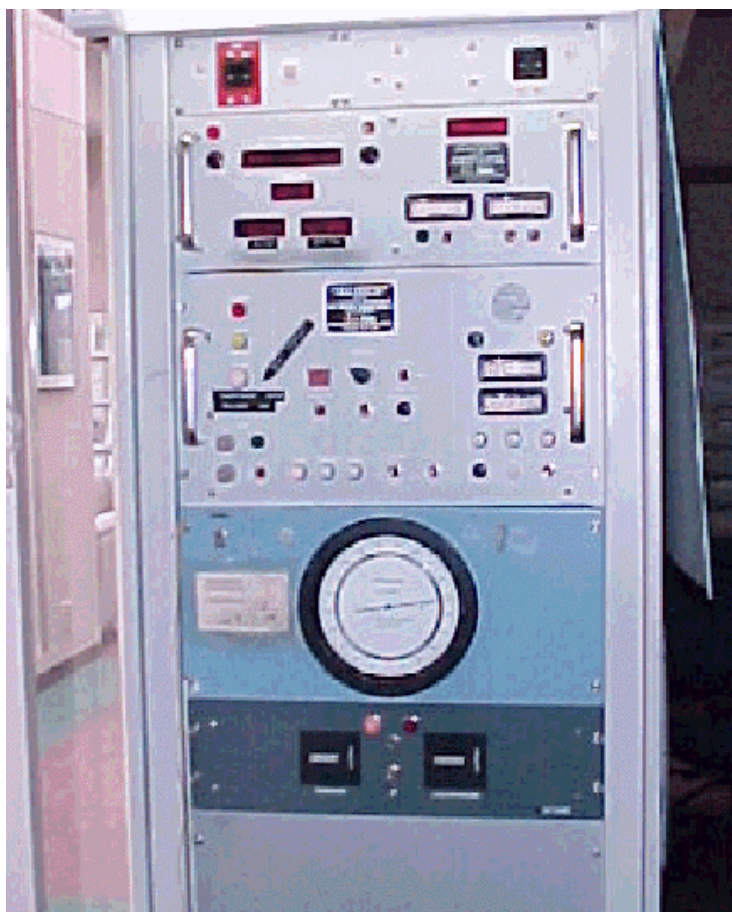

Figure B-7 - Master Control Unit

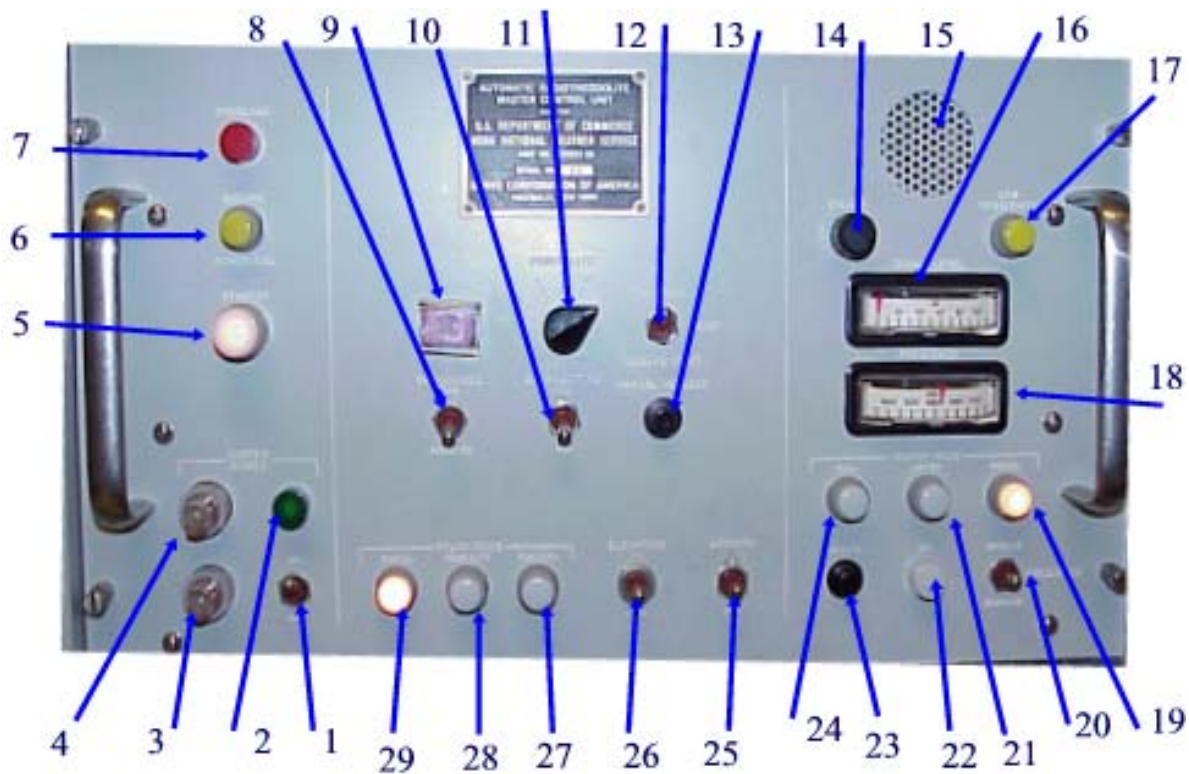

Figure B-8 - Master Control Unit Close-Up
 (Arrowed numerals correspond to functions listed in Table B-1)

Table B-1 - Master Control Unit - Numbers correspond to the respective controls in Figure B-8

No.	Master Control Unit (MCU)	Function
1	ON/OFF Switch	Entire RDF System
2	INDICATOR	Green lamp is lit if master ON/OFF is set ON and if In-Radome REC/ANT control panel is set To ON.
3	2 AMP Fuseholder	When Fuse F1 is blown, neon lamp glows amber.
4	2 AMP Fuseholder	When Fuse F2 is blown, neon lamp glows amber.
5	STANDBY (Indicator Switch)	White button switch. Azimuth and elevation drives and scan motor can be toggled on/off.
6	RADOME/POWER FAIL	Yellow button indicator/reset switch will alert you to the general state of radome power (on/off).
7	OVERLOAD	Red button lights when the azimuth or elevation drives get overloaded. (If overload occurs, the drives automatically de-energize.)

8	RADIOSONDE (Switch)	No longer used. The switch should be left in the Time position (Up) as the default.
9	STOP PRINT	Red button switch stops the elapsed time on the Ang/Time LED display.
10	ELAPSED TIME	Toggle switch. When in RUN position (down) it displays the elapsed time. The HOLD position (up) stops the running display, but keeps the clock incrementing (can restore running display with RUN command).
11	PRINT RATE	Used with the wind data printer-Allows the print rate to vary. Useful when doing optical comparisons.
12	PRINT	This function has no effect on the MicroART workstation. It will affect the wind data printer if used at the site.
13	MANUAL RELEASE	Black momentary push-button, when pressed sends release signal to start the ELAPSED TIME Display and starts data capture.
14	VOLUME	Black knob adjusts the audio level of the loudspeaker.
15	LOUDSPEAKER	Produces an audible sound of incoming MET data and release tones.
16	SIGNAL LEVEL	A meter that displays the incoming signal level from 0 to 100 db in 10 db increments.
17	LOW SENSITIVITY	Yellow push-button toggle switch puts the receiver into a low sensitivity mode. [When SYSTEM POWER switch is set ON (Yellow button is lit), the receiver is automatically set to low sensitivity.]
18	FREQUENCY METER	Displays frequency 1655-1705 MHZ in 5 MHZ increments. Intermediate values are interpolated.
19	SEARCH MODE – MANUAL	White push-button switch when pressed (illuminates) puts the receiver into MANUAL SEARCH MODE.
20	FREQUENCY	Toggle switch is usually off (neutral). Used in MANUAL SEARCH mode. When in INCREASE position (up) the receiver frequency (MHZ) is increased when in DECREASE position (down) the receiver frequency (MHZ) is decreased.
21	SEARCH MODE – LIMITED	White push-button switch when pressed (illuminates) puts receiver into LIMITED SEARCH mode.
22	AFC Indicator	White indicator lamp. Lamp illuminates when system is locked-on to a received signal.

23	INITIATE	Black push-button (momentary) switch when FULL SEARCH MODE switch is illuminated and switch is pressed the receiver is put into FULL SEARCH MODE.
23	INITIATE	Black push-button (momentary) switch when FULL SEARCH MODE switch is illuminated and switch is pressed the receiver is put into FULL SEARCH MODE.
24	SEARCH MODE - FULL	White push-button switch when pressed (illuminates) and system is capable of being put into FULL SEARCH MODE via the INITIATE switch.
25	AZIMUTH	Toggle switch is usually off (neutral). Can be used in all track modes. When in CW position (up) the tracking dish turns through the compass in a CW direction. When in CCW (down) dish turns in CCW direction.
26	ELEVATION	Toggle switch is usually off (neutral). Can be used in all track modes. When held in UP position (up), the dish increases its elevation angle. When in DOWN (down), the elevation angle of the dish is decreased.
27	TRACK MODE – FAR AUTO	White push-button switch when pressed (illuminates) makes system tracking automatic for tracking a balloon with slow angular changes.
28	TRACK MODE – NEAR AUTO	White push-button switch when pressed (illuminates) makes system tracking automatic for tracking a balloon with rapid angular changes.
29	TRACK MODE – MANUAL	White push-button when pressed (illuminates) disengages system from automatic tracking and places system into manual track mode. USE toggle switches to adjust the antenna position in elevation and azimuth for tracking the balloon.

NOTE for # 5: CAUTION should be exercised in use of the STANDBY switch. Repeated overloading indicates malfunctioning equipment. Repeated overloading and resetting could cause costly damage to the equipment.

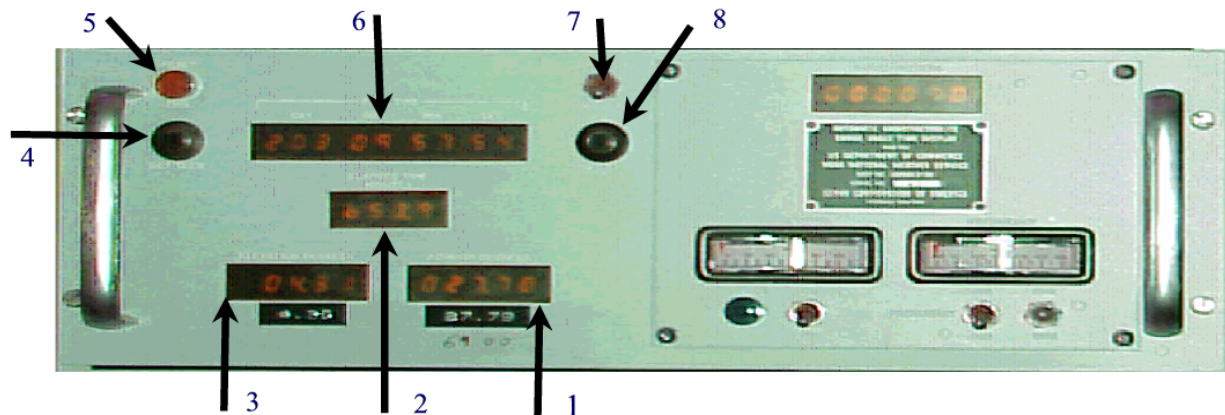

Figure B-9 - Angle/Time Display

Table B-2-Angle/Time Display Rack-Numbers correspond to respective controls in Figure B-9.

No.	ANGLE / TIME CONTROLS	FUNCTIONS TO DISPLAY ANGLE / TIME
1	ELEVATION DEGREES	Red LED display gives tracking dish angles from -5° to $+95^{\circ}$ in 0.01° increments.
2	ELAPSED TIME MINUTES	Red LED display gives time from the launch, when release button was pressed, in 0.1 minute (six second) increments.
3	AZIMUTH DEGREES	Red LED display gives the tracking dish azimuth angle from 0° - 360° in 0.01° increments.
4	DAY SLEW	REAL TIME DAY display - Two-step button, when partially depressed slowly slews. When fully depressed, slews rapidly.
5	RESET TIME	Red button indicator illuminates when power is interrupted and the REAL TIME might be incorrect.
6	REAL TIME	Red LED display gives REAL TIME in days, hours, minutes, and seconds {UTC}.
7	TIME-SET/INHIBIT	Toggle switch. When TIME-SET is selected, use the TIME SLEW and DAY SLEW switches to change the real time. When in INHIBIT the slew switches are inoperative.
8	TIME SLEW	Two-step button, when partially depressed slowly slews the REAL TIME display, when fully; it rapidly slews the displayed REAL TIME.

2.5 Remote Control Unit. The Remote Control Unit (RCU) is an all-weather control panel mounted outside the inflation shelter. The panel is used to synchronize RDF electronics and MicroART data processing with the exact launch time. This may be initiated by pressing the release button (#6, Figure B-11), or by using the timed release option that has a 60 second timed delay (#5, Figure B-11). The timer generates an audible series of preliminary tones and concludes with a tone for the observer to release the balloon. The remote control unit is fully integrated with the tracking system atop the inflation shelter. The remote panel is a control position for each of the receiver and antenna operational modes and includes a manual override for each.

Note: To avoid height errors the preferred launch technique is to use the Timed Release option with the remote switch.

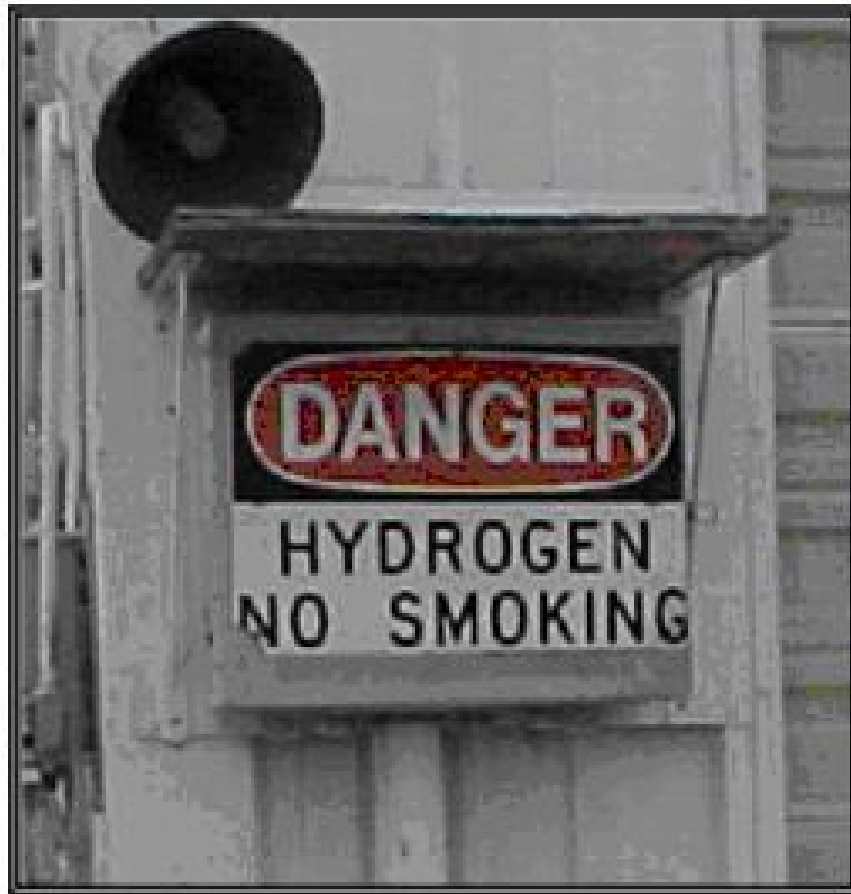

Figure B-10 - Closed Remote Control Panel with Rain Cover

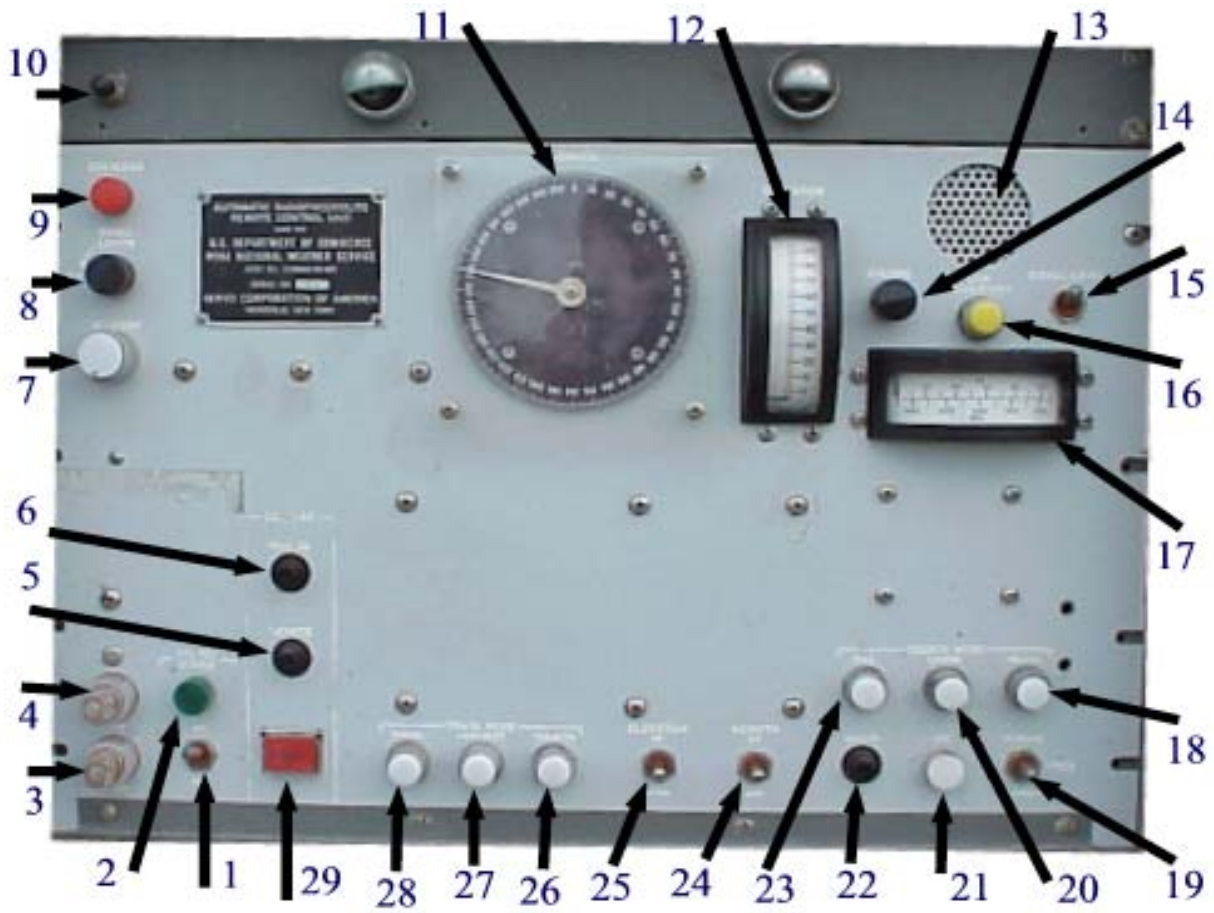

Figure B-11 - Open Remote Control Panel

Table B-3 - Remote Control Panel - Numbers corresponds to the respective controls in Figure B-11.

No.	Remote Panel Controls	Function
1	On/Off Switch	Set to On to activate the entire RDF system.
2	Indicator	Green lamp is lit if remote On/Off is set On and if In-Radome ANT/REC control panel is set to On.
3	0.5 AMP Fuseholder	If Fuse F1 is blown - Neon lamp is lit.
4	0.5 AMP Fuseholder	If Fuse F2 is blown - Neon lamp is lit.
5	Release/Remote Switch	Press & hold to send a release signal to start the Elapsed Time display, Met Data Recorder, 60 seconds after button is pressed.
6	Release/Manual Switch	Press & hold to send a release signal to start the Elapsed Time display, Met Data Recorder. In Simulator Mode, it also starts Simulator.
7	Standby Indicator Switch	When the MCU's Standby toggle button is pressed-in (white lamp), or either the ANT/REC, or RCU, Standby buttons are pressed, the Azimuth and Elevation drives and Scan Motor are de-energized.
8	Panel Lights Dim Control	Adjusts the illumination level of the front panel.
9	Overload Indicator	When there is an overload in the Azimuth or El Drives the red lamp illuminates. Drives are de-energized.
10	Door Open Switch	Permits Front Panel lamps and RCU Panel Supply to be powered, if needed, when door is open.
11	Azimuth Indicator	Shows the azimuth angle (0 to 360) of the tracking dish. Measured in 1 degree increments.
12	Elevation Meter	Shows the elevation angle (-5 to +95) of tracking dish. Measured in 1 degree increments.
13	Loudspeaker	Gives audible repetition rate of incoming MET Data and release tones.
14	Volume Control	Adjusts the audio level of the loudspeaker.
15	Signal Level/Freq Switch	Dual Indicator. When set to Signal level shows strength in dB. When set to Frequency, shows the frequency setting of the receiver in MHz.
16	Low Sensitivity Indicator Switch	This is a push switch for Low/High sensitivity. A lit yellow lamp indicates Low sensitivity. An unlit lamp indicates, high.
17	Signal Level/Freq Meter	Dual purpose meter. Gives a scale for signal strength (0 to 110 dB), in 10 dB increments; and for frequency (1655 to 1705 MHz) in 5 MHz increments.
18	Search Mode: Manual	Press-in (white lamp illuminates) to put into Manual Search Mode.
19	Frequency Increase/ Decrease	Usually is off. Hold in the Increase position to

	Switch	increase the receiver frequency, hold in the Decrease position to decrease it.
20	Search Mode: Limited	Press-in (white lamp illuminates) to put receiver into Limited Search Mode. {Seems to be toggle}
21	AFC Indicator	The white lamp is lit when system is locked-on to a received signal.
22	Initiate Switch	Press-in this switch to enter Full Search Mode when the Full Indicator Switch is lit.
23	Full Indicator Switch	Press-in (white lamp) to enable receiver to be placed into Full Search Mode (see Initiate switch).
24	Azimuth CW/CCW Switch	Usually is off. Hold in a CW position to move tracking dish in a clockwise direction. Hold in a CCW position to move dish in a counter-clockwise direction.
25	Elevation UP/DN Switch	Usually is off. Hold in the UP position to increase the dish's elevation angle. When held in a down position, will decrease the elevation angle. Can be used in all track modes.
26	Track Mode: Far Auto	Press-in (white lamp) to make system automatically and slowly track balloon.
27	Track Mode: Near Auto Indicator Switch	Press-in (white lamp) to make system automatically and rapidly track balloon.
28	Track Mode: Manual Indicator Switch	Press-in (white lamp) to place system into manual track. With separate controls you need to input elevation and azimuth values with proper rates.
29	Release / Abort Switch	Press-in to cancel the remote release sequence. It will cancel the process started by the Remote/Release switch.

3. NAVAID Network Stations. The LORAN system consists of a coordinated network of four or five stations called a chain. Each chain transmits on a 100 Kilohertz (KHz) {carrier} a series of pulses, in a specific sequence. When all stations have transmitted, there is a final predetermined delay after which the master station again begins the cycle. The period of this multi-station transmission cycle is about 0.1 second.

Radiosondes are designed with an onboard tracker to receive and lock-on to each station in the chain. The tracker will observe the master station and at least two secondary stations, and then report the time at which each station is received in relation to the master station. Analogously, time segments can be converted to distance segments respectively from each station. At this point, the onboard processor computes the equivalent of a circular locus about each station, and then calculates the point where all three intersect. This point of intersection is the precise fix of the radiosonde. (As with RDF, the altitude of the radiosonde cannot be determined with this tracking system).

Most NAVAID radiosondes transmit on a 403 MHz carrier and use the same modulation (e.g., Meteorological Data Oscillator) process as conventional radiosondes. When the radiosonde is within 7 miles, the signal is received with an Omni directional antenna, and at the farther ranges with a Yagi Ultra High Frequency (UHF) antenna. Operating instructions for NWS sites using LORAN tracking can be found in the VIZ WL9000 Operator's Manual.

It is important to note that observational data can be degraded and/or lost due to the following limitations associated with use of Navigational Aid (NAVAID) networks:

- a. Poor location of LORAN transmitters with respect to the release point (i.e., perspective of transmitter's forms a narrow angle or one transmitter located too close to release site).
- b. Inadequate, or absence of a, telemetry repeater/relay between the observation path and data processing station.
- c. High electric fields induced by thunderstorms or snowfall (LORAN only) in the vicinity of radiosonde.
- d. Radio interference, sometimes due to increased solar activity, especially for the 403 MHz band radiosondes.
- e. Temporary loss of LORAN signal lock immediately following balloon launch.
- f. Poor calibration of ground equipment.

4. Global Positioning System (GPS). The GPS consists of a global, integrated network of twenty-four global positioning satellites that operate on a frequency of 1575 MHz. Basic triangulation for wind determination requires reception from at least three GPS satellites. Positional data plus height calculation requires a minimum signal lock from four satellites. The high rate of microprocessor clock-speed applied to the triangulation equations makes possible the most precise location finding system available.

4.1. Telemetry Receiving System (TRS). The TRS was designed and built by International Meteorological (Met) Systems (Inter Met) for the National Weather Service. The TRS receives Meteorological Data transmitted over the 1680 MHz band from the radiosonde at a nominal 1 Hz rate and sends the received data to the Signal Processing System (SPS) via a 10.7 MHz signal. The SPS performs the required decoding of the received signal to generate the meteorological and GPS data measured by the sensors in the radiosonde. The SPS uses this data, together with GPS data from a local receiver, to compute atmospheric pressure, temperature, humidity and wind from the radiosonde each second. The SPS sends the computed results to the workstation which controls the operation of the RRS and produces the coded messages and archive. It operates with radiosondes and SPS and meets the TRS and SPS interface and data requirements.

The TRS works on the principle of an Automatic Radiotheodolite. A two-meter parabolic dish

antenna is mounted on a movable frame to allow for both azimuth and elevation movements. Movements are accomplished by servomotors under the control of the TRS Motion Control Unit (MCU). All electronic and mechanical elements required for acquiring the transmitted signal and maintaining the orientation of the antenna are contained in the antenna assembly.

Within the TRS pedestal, there is a 19" rack of electronic components that provide power to the antenna, manage communications within the TRS, process the telemetry received by the antenna and transmit data to the workstation. There are also components which provide control of the environment for those components within the 19" rack which cannot tolerate the extremes of the TRS environment.

Antenna functions can be controlled by the workstation or by the two Control Display Units (CDUs) included with the system.

4.1.1 Physical Description. The TRS consists of three units which are the antenna unit, workstation unit and launch area unit. Within the antenna unit, there are three major functional groups which are the RF group, yoke group and rack group.

Each of these groups consists of mechanical parts, electronic assemblies and cables. See figures B-12, B-13 and Table B-4 for more information.

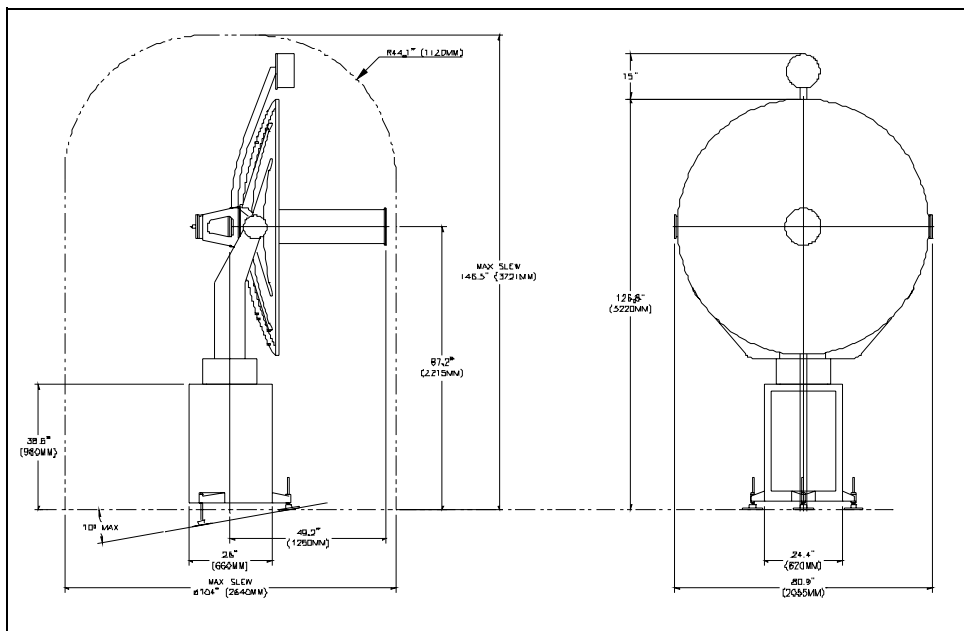

Figure B-12: TRS Installation Size

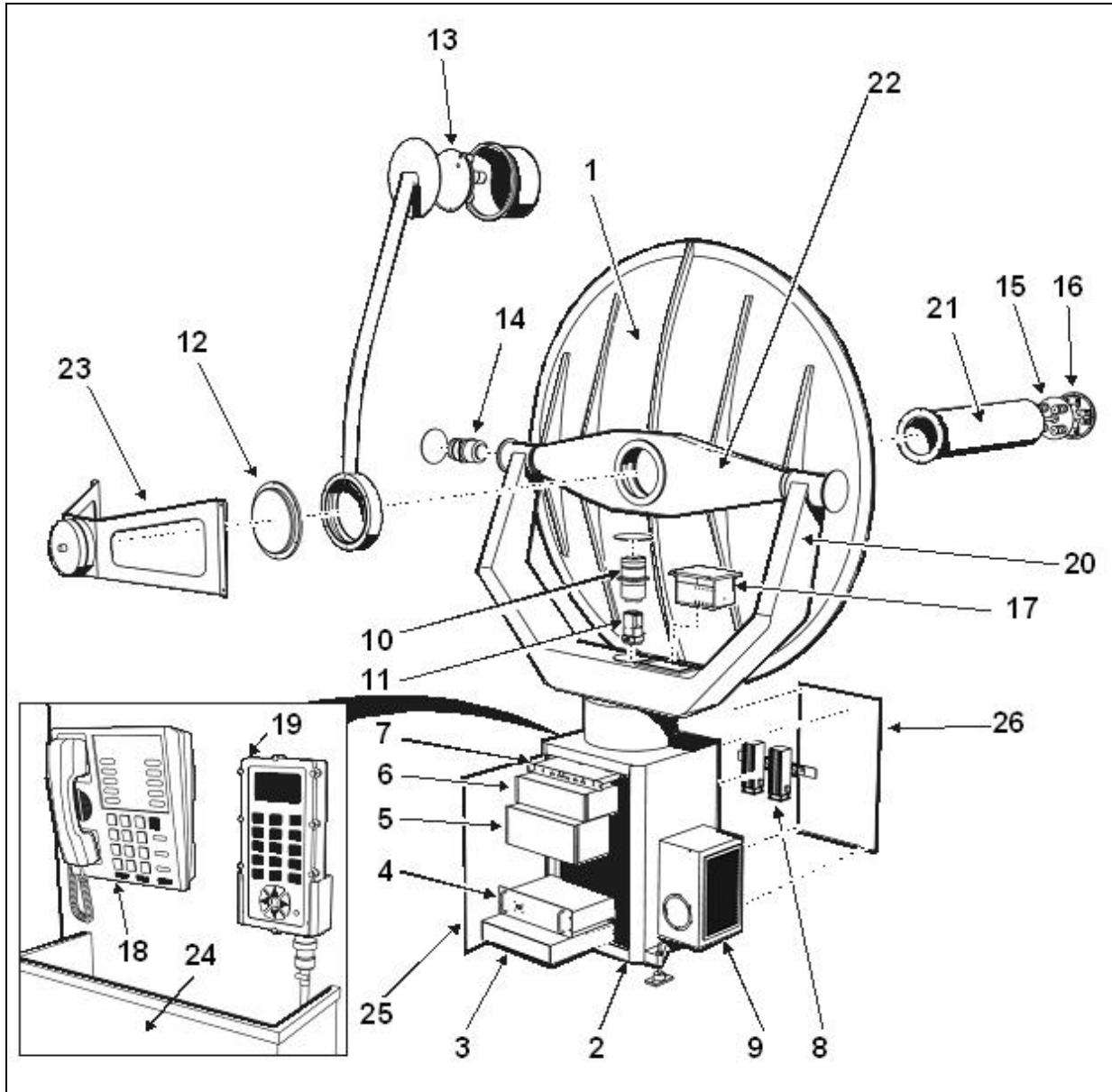

Figure B-13: Antenna Unit

Table B-4: Antenna Unit Assemblies

Figure B-13 IPB Item#	Description	ASN/Ref Des. (J700-)	Part Number
1	Main Dish		
	RF Group	1A1	
12	Receiver Assembly	1A1A1	J700-41068-10
15, 16, 21	Scanner Unit Assembly	1A1A2	J700-41067-10
16	Scanner Assembly	1A1A2A1	J700-41075-10
15	Helix Assembly	1A1A2A2	J700-41135-10
13	Wide Angle Gathering Sensor (WAGS)	1A1A3A1	J700-41160-10
20	Yoke Group	1A2	
14	Elevation Motor Drive Assembly	1A2A1	J700-41142-10
10	Azimuth Motor Drive Assembly	1A2A2	J700-41142-10
17	Motion Control Unit	1A2A3	J700-41137-10
11	Slip ring Assembly	1A2A4	J700-41062-10
22	Cross member	1A2A5	J700-YYYY
2	19" Rack Group	1A3	
7	Systems Communication Assembly	1A3A3	J700-41072-10
6	Antenna DCE	1A3A4	J700-90015-1
8	Heater Assembly	1A3A6	J700-41801-10
5	Signal Processing System	1A3A7	N/A
4	Power Supply Assembly	1A3A8	J700-41803-10
3	Uninterruptible Power Supply	1A3A9	J700-90003-1
18	Local Area Intercom	1A3A10	J700-90007-1
19	CDU Assembly	1A3A11	J700-41074-10
9	Air Conditioner	1A3A12	J700-90002-1

The Uninterruptible Power Supply (UPS) is a standard 19-inch rack mount unit mounted in the rack below the antenna. Refer to Table B-4 item 3. It provides the distribution backup air conditioner (AC) line power to operate the entire TRS local and launch area components (except the heaters and AC) for at least 10 minutes after loss of power.

The heaters thermostatically control the environment within the 19 inch rack area to be greater than 0 degrees Celsius and less than 95% relative humidity (RH).

The A/C thermostatically controls the environment within the 19 inch rack area to be less than 40 degrees Celsius and less than 95% relative humidity (RH). The condensate hose, if used, is connected from the A/C and allowed to run out an air vent at the base of the radome.

4.1.2 Major Components.

4.1.2.1 The Dish. The dish is a 2 meter diameter parabolic reflector with a 1 meter focal length and consists of two halves for ease of transportation to the sites. Each half is a sandwich construction containing an aluminum mesh grid sealed between two glass fiber layers. The concave surface of each half is protected with a gel coat. The two halves each have a vertical flange, which are bolted together at the time of installation. Each dish half has two vertical aluminum struts attached to it, which provide stiffening to the structure for mounting the dish to the cross-member. Refer to Figure B-13 item 1.

4.1.2.2 The Receiver. The 1680MHz TRS receiver is contained in an aluminum housing mounted onto the rear of the member directly behind the scanner tube. All electrical connections to the receiver are made within the cross-member to protect cabling and connectors from the environment. The synthesized receiver down-converts the received radiosondes signal from the 1680 MHz band to an Intermediate Frequency (IF) at 10.7 MHz. The receiver operates under microcontroller supervision and control.

The received radiosonde signal passes through several filters and down converted to the 10.7 MHz (Intermediate Frequency) IF output frequency. It is the IF output signal modulated with the radiosonde data and the AM component modulated by the scanner. It is controlled by Automatic Frequency Control (AFC) to 13 dBm at 50 ohms. The synthesized receiver implements various tuning modes as well as AFC to ensure signal stability. The data channel's output level is maintained by the AFC system. A demodulated, base-band AM signal containing the tracking amplitude information is also extracted from the radiosonde signal.

The receiver operates under the control of a programmable microcontroller. A communications bus is provided for control of the receiver and access to the Electrically Erasable Programmable Read Only Memory (EEPROM). The EEPROM is used to store calibration data that permits field swapping of the receiver without further calibration adjustments to the station. The calibration includes data relating to frequency selection, signal strength, AFC control, AFC sensitivity and defaults. This data is set up in the factory. All communications are over this serial interface. The microcontroller is able to implement AFC and search tuning on the receiver. The receiver provides demodulated, base-band AM and FM signals for use in the Systems Communication Assembly (SCA). The AM signal is used to control antenna tracking.

4.1.2.3 Motor Drive Assemblies. There are two motor drive assemblies in the TRS. One controls the azimuth movement while the other controls elevation. The two motor drives are identical and interchangeable. The motor assembly consists of a DC motor, gearbox, shaft interface, motor drive board and position encoder. The motor drive board mounts on the back part of the motor assembly and converts low-voltage control signals into power output to the motor.

4.1.2.4 Launch Area Box. The launch area box contains the launch area CDU with its cabling, and the launch area intercom and ringer. Refer to figure B-14 item 1.

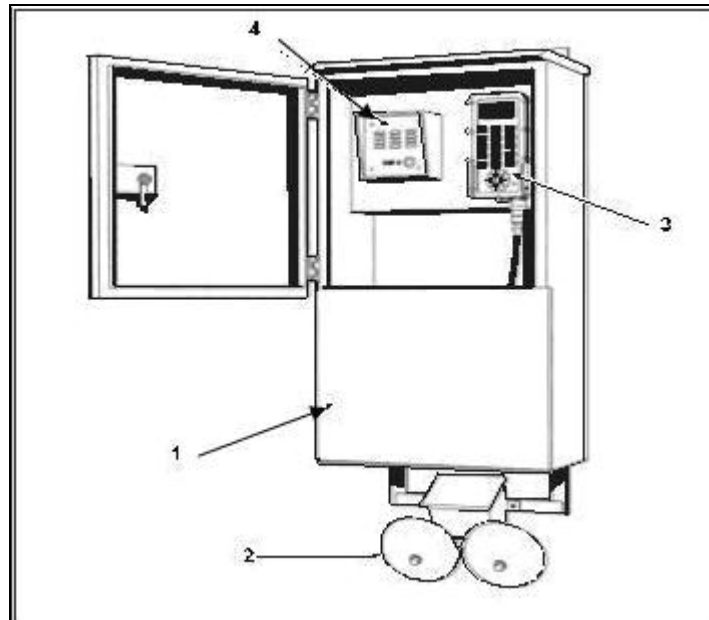

Figure B-14 – Launch Area Unit

Table B-5: Launch Area Unit Assemblies

Table B-5			
IPB Item #	Description	Ref Des.	Part Number
1	Launch Area Box	3A1	J700-41099-10
2	Launch Area Ringer	3A1A3	J700-90014-1
3	Launch Area CDU	3A1A1	J700-41074-10
4	Launch Area Intercom	3A1A2	J700-90008-1

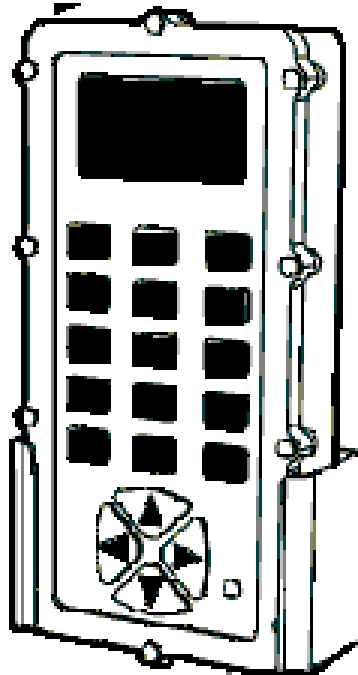

Figure B-15 - CDU

4.1.2.4.1 Launch Area Control Display Unit. The launch area control display unit (CDU) is mounted in the launch area box next to the launch area intercom. Refer to Figure B-14 item 3. There is also a CDU located in the radome. This CDU is referred as the Local CDU. The two hand-held CDUs are identical. They incorporate a back-lit keyboard, beeper, back-lit Liquid Crystal Display (LCD), Central Processing Unit (CPU), RS-422 interface and power supply. The CDUs are used to facilitate local, direct control and monitoring of the operation of the antenna assembly. They implement a sub-set of the standard command set of the station, allowing them to execute various operations including slewing, tracking, target acquisition, receiver control, reference set-ups, data and status polling and launching of built-in-tests. They provide the audio output of the sonde modulation or the receiver tuning aid. Information on how to use the CDUs is contained in Section 4.4.2.

The local CDU can be used to override ("lock-out") commands from the launch area CDU and the workstation. This gives a technician working at the antenna site the ability to control the antenna assembly and prevent unexpected movement caused from commands given by the other CDU or the workstation.

The CDU Processor Board is the standard TRS processor block including microcontroller, RAM, ROM and interfaces. It processes commands and data, requests receiver operations and antenna movements.

The CDU com port is a digital data channel carrying communications between the CDU and the

TRS antenna assembly. The CDU com port is a full-duplex RS-422 asynchronous serial channel at 19,200 baud with 8 data bits, 1 stop bit and no parity. The FM baseband signal contains the radiosonde modulation data. It is an audio frequency radiosonde modulation signal. The system power provides all power for the functions of the CDU (nominally +24 vdc.). The system power is converted to voltages suitable for use by the CDU.

There is one cable plugged into the CDU: The launch area CDU cable connects the launch area CDU Extension Cable to the CDU.

4.1.2.4.2 Launch Area Intercom. The launch area intercom is a rugged speakerphone which provides hands free operation. Refer to Figure B-14 item 4. There are two cables plugged into the launch area intercom:

- a. The launch area intercom cable connects the bulkhead to the launch area intercom.
- b. The launch area ringer cable connects the launch area ringer to the launch area intercom.

4.1.2.4.3 Launch Area Ringer: The launch area ringer provides a loud ring when there is an incoming call from the workstation. Refer to Figure B-14 item 2. There is one cable plugged into the launch area ringer. The launch area ringer cable connects the launch area intercom to the launch area ringer.

4.2 Overall System Description. The TRS works on the principle of an automatic radiotheodolite. A two-meter parabolic dish is mounted on a movable frame that allows for independent azimuth and elevation movements. A scanning antenna mounted at the end of the bore sight tube receives and samples the incoming Radio Frequency (RF) signal by electronically switching between four helical elements.

The antenna measures relative signal strength between the four elements to generate azimuth and elevation error values relative to bore sight. The Motion Control Unit commands the azimuth and elevation servomotors to move the antenna as necessary to minimize the error signals. This allows the antenna to track a radiosonde transmitting at low power on the 1680 MHz band.

Along with Precipitation, Temperature and Humidity (PTU), a TRS compatible radiosonde transmits GPS coordinates. These coordinates are received by the TRS and passed on to the SPS where differential correction is applied. This information is then passed via the Digital Communication Equipment (DCE) to the workstation where wind speed and direction are calculated.

The TRS radiotheodolite uses GPS technology for wind finding and RDF technology for tracking. The antenna uses the azimuth and elevation errors to maintain maximum contact with the radiosonde transmitter but not to derive wind speed and direction. By combining the two

methodologies, TRS seeks to achieve the highest possible range and accuracy of signal reception.

4.3 Overall System Operation.

4.3.1 Automatic Operation. As an automatic radiotheodolite, the TRS is intended to operate with minimal user intervention once the radiosonde signal is acquired and locked on. In situations where the signal is lost, the system includes two search patterns that can be activated by the operator to try to locate the radiosonde signal and return to automatic tracking mode.

The operator prepares a radiosonde and balloon in accordance with their published procedures. The TRS is powered on and automatically executes its initialization. Once complete, the TRS receiver is tuned to the radiosonde. Via the workstation, the operator executes the pre-observation procedures. Once complete, the radiosonde is carried to the balloon where it is attached via the balloon train. Walking the balloon and radiosonde from the inflation building to the launch area, the operator uses the Launch Area Control Display Unit (CDU) to put the TRS into the automatic tracking mode. Since the radiosonde is close to the TRS, the tracking is accomplished using the Wide Angle Gathering Sensor (WAGS). In this mode, the TRS will track the radiosonde through the early part of the launch. Shortly after launch the tracking transfers from the WAGS to the Narrow Angle Gathering Sensor (NAGS). This tracking mode is used for the remainder of the observation.

Do not follow this procedure when overhead conditions exist. Leave the TRS in manual track mode until you return to the Radiosonde Replacement System Workstation (RWS) workstation. Then use the latest azimuth and elevation information in the processed data display to manually point the antenna at the radiosonde and place the TRS in automatic track mode.

Note: The beam width of WAGS is 100 degrees and the beam width of NAGS is 15 degrees. These values are important to remember to ensure the receiver has not initially locked onto a side lobe.

4.3.2 Manual Operation. The TRS can be operated in manual mode by entering slew commands via the CDU or workstation, or by entering numeric azimuth and elevation coordinates. Basic user options include the following:

- a. Automatic frequency control on/off.
- b. Manual frequency set.
- c. Automatic frequency search.
- d. Automatic level control on/off.
- e. Automatic tracking on/off.
- f. Relative position set.
- g. Absolute position set.
- h. Limited search.

i. Full search.

All of the available operating modes and procedures are described in Section 4.4.2.

4.4 Tracking. Automatic tracking of the Line-Of-Sight (LOS) to a radiosonde is provided by the Scanner, Receiver, MCU and Motor Assemblies all working together.

The TRS continuously tracks a radiosonde from launch until termination of the observation as the radiosonde is carried up through the atmosphere by an aerological balloon. The TRS is designed to be operated by a CDU, or by commands from a workstation.

There are three sources of control for the TRS. They are the Local Area CDU, the launch area CDU and the government provided workstation. The two CDUs are mechanically and electrically identical. The functional differences are learned by the CDU from its connection to the TRS, i.e., the TRS tells the CDU how to behave. The launch area CDU is located in the launch area box but because of its long cable, can be operated by as much as 50 feet away from the launch area box. The local area CDU is located in the radome but because of its cable length, can be operated from anywhere within the radome or just outside of the radome door. Both locations provide a mounting bracket for the CDU and excess cable storage. This is especially important for the launch area CDU to protect it from weather and the damaging effect of radiation from the sun.

The operating procedures contained in this appendix cover commands initiated by either of the two CDUs. It also contains procedures for the climate control of the equipments within the 19" rack, and the power and communications control of the entire system. Operation of the TRS by the workstation is not part of this manual.

4.4.1 Control Display Unit. Each CDU is housed in a light-weight rectangular metal casing. The width of the casing is such that it is easily held in one hand. An LCD is mounted in the upper section of the face of the casing. Each CDU incorporates a keypad on the lower section of the face of the casing for numeric and functional operations plus a set of direction controls for slew/level control. Each CDU has an interface cable which is connected between the base of the CDU and the Systems Communication Assembly (SCA).

The display is a 120 x 64 pixel graphics LCD module. The LCD includes backlighting, and has an extended temperature operating range. The backlighting is permanently enabled. The keypad consists of 15 keys, arranged in a 3x5 matrix and 4 direction control keys, as shown in a graphic representation in Figure B-16. A short, fixed-volume beep accompanies each key press (or key repeat).

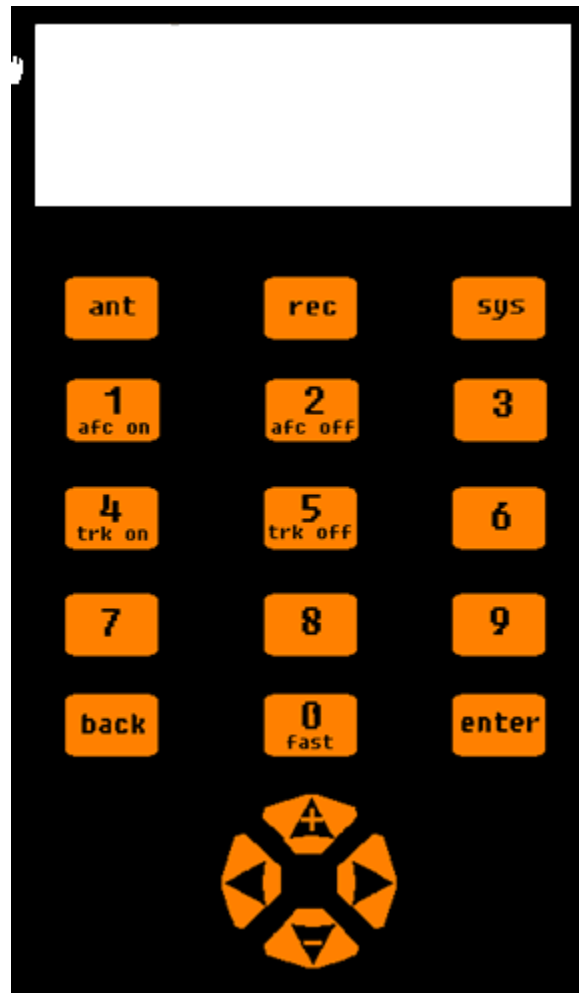

Figure B-16 – CDU Keyboard

4.4.2 User Interface. Control of the station and CDU is achieved via an interface that implements quick, logical steps to guide the user to the desired result. Often, used functions are available with a minimal of key strokes and screen changes. Feedback to user input is apparent, positive and effectively instantaneous.

Space constraints on the keyboard dictate that functions be accessible by a menu selection system. Often-used functions are implemented to require a minimum number of keystrokes before they are executed. There is a main or default display mode called the idle state and three functional menu driven modes relating to the Antenna or “Ant” functions, the Receiver or “Rec” functions and the System of “Sys” functions. Intermediate or error screens indicate time delays or response failures from the system.

Idle State Overview

The idle state is the most used mode and functions available from it require the fewest keystrokes.

Idle State

Under routine conditions, the CDU is in the idle state. In this state, the screen gives an upper level set of data on the station operation. It is displayed and updated at a suitable rate such that the observer has fresh, flicker-less data required for the situation. The data screen that is displayed in this state may also be selected via the SYS key and the data sub-menu.

After initialization, the CDU begins operation in the idle state. Some data entry requires selection of menus, perhaps submenus, and entry of numeric data to complete an operator instituted action. If the operator has stopped pressing keys before finishing the key-stroke action, and approximately 60 seconds elapses with no keys being selected, the non-completed key-strokes or operations are cancelled and the CDU reverts to the idle state.

Menus

Numeric-selection menus are used to guide the user in their choice at a particular state. Selection of an item is achieved by pressing the appropriate numeric key. The Back key is used to revert to the menu level or state prior to the one currently displayed.

Keyboard

Some of the numeric keys are used for quick access to often-used functions. These functions are available when the CDU is not expecting a numeric input. The functions are AFC On/Off and Tracking On/Off.

The numeric keys are used to select numbered menu items, or to enter numeric data. A fixed decimal place position is indicated in entry fields for floating-point numbers. The Back key is used to delete individual numbers entered in a numeric entry screen. If a menu is displayed, this key is used to revert to the menu level state above the one currently displayed.

The 3 menu keys across the top row, if pressed, cause the CDU and station to abort the current operation menu or state and display the applicable top-level menu for the particular menu key pressed.

Direction Controls

The direction control keys, in combination with the "0/fast" key, slew the antenna when the CDU is in the idle state. The speed of slewing is dependent on the length of time the key(s) are held down. Table B-6 details the operation of the direction control keys.

Table B-6: Direction Controls

INITIAL SLEWING SPEED	ACTION	FINAL SLEWING SPEED
Antenna stationary	Direction control pressed without "0/fast"	1° / second
Antenna stationary	Direction control pressed without "0/fast"	10° / second
1° / second	Direction control held for > 4 seconds	5° / second
1° / second	"0/ fast" key pressed	10° / second
5° / second	"0/ fast" key pressed	20° / second
5° / second	Direction control released and repressed	1° / second
10° / second	Direction control held for > 4 seconds	20° / second
10° / second	0/ fast" key released	1° / second
20° / second	Direction control released and repressed	10° / second
20° / second	0/ fast" key released	5° / second

Elevation and azimuth slewing movements may be obtained simultaneously by pressing both vertical and horizontal direction keys. Should the station be operating in auto-tracking mode when a direction control key is pressed, the station is taken out of the auto-tracking mode and set to manual mode if that key is pressed for at least ½ second. The observer presses the "Track on" key to resume auto-tracking after manually slewing the dish.

Antenna slewing via the direction keys is not active in non-idle state screens.

The Up (+) and Down (-) direction control keys are also used in the following situations:

- a. Manual tuning the four available tuning speeds, using the analogy of tuning speed versus angular rotation speeds, are 10 kHz, 100 kHz, 500 kHz and 1 MHz per second.
- b. Volume level - under the SYS menu.
- c. LCD contrast adjustment - under the SYS menu.
- d. To add a "+" or '-' to the front of signed numeric data entries.

Antenna Menu Key. Pressing the “ANT” key causes the CDU to display a menu of operations related to the control and positioning of the antenna. Options 2, 3 and 4 are not displayed when the station is operating in the Auto Tracking Mode.

ANTENNA CONTROL	
1. Position	4. Auto
2. To Zero	5. Manual
3. Search	6. Calib

Antenna Positioning. When option 1 is pressed, the CDU displays a level 2 menu screen. In this condition, the user is asked whether the desired movement is to be to an absolute position, or if a relative movement is desired.

ANTENNA POSITIONING
1. Absolute
2. Relative

Selection of option 1 causes the CDU to display the following screen:

ABSOLUTE POSITIONING
1. Azimuth
2. Elevation

Selection of option 1 or 2 causes the CDU to display a numerical data entry screen. The screen for option 1 is shown below:

ABSOLUTE POSITIONING
Azimuth +000.00°

Numerical entry is now permitted. Numbers are entered at the right hand position, and scroll towards the left. The sign of the entry can be altered using the direction control keys (Up = '+', Down = '-'). The Back key deletes the last number entered, and scrolls all other numbers one position to the right. Pressing back when the display shows 000.00, returns the CDU to the previous screen. The ENTER key terminates the operation. On pressing ENTER, the station implements the desired movement in the selected axis, and the CDU returns to the idle state. Range checking is initiated checking for Azimuth entries outside -360.00 to +360.00 and elevation entries outside -10.00 to +91.50. Entries outside of these ranges produce an audible and visual warning. The user may then modify the value.

<p>ABSOLUTE POSITIONING</p> <p>Elevation -012.49 °</p> <p>ERROR: Illegal Entry</p>
--

If option 2 (relative positioning) is selected in the level 2 menu screen above, the CDU displays the following level 2 menu screen:

<p>RELATIVE POSITIONING</p> <p>1. Azimuth 2. Elevation</p>

Selection of option 1 or 2 causes the CDU to display a numerical data entry screen. The operation proceeds as previously detailed.

The maximum relative movement in the Azimuth axis is $\pm 180.00^\circ$. The maximum relative movement in the Elevation axis is $\pm 101.50^\circ$.

Zero Position. When option 2 is pressed, the CDU displays the following level 2 menu screen:

<p>RELATIVE POSITIONING</p> <p>1. Azimuth 2. Elevation 3. Both Axis</p>

Selection of an option causes the station to slew the selected antenna axis or axes to the 0.00° position and the CDU returns to the idle state.

Antenna (Limited) Search. When option 3 is pressed, the CDU starts with requests for further data entry before a limited search is begun. Limited search moves the antenna in azimuth and elevation over a limited range of angles attempting to find the direction to point to maximize the signal received from the radiosonde. A numerical data entry screen is displayed for entry of the expected signal strength of the radiosonde when it is located. The value entered here is stored for recall as the initial value for this entry the next time that a search is requested.

<p>ANTENNA SEARCH</p> <p>Find a signal above -065 dbm</p>

The next screen is used to enter the cone angle of the search. This is the maximum angle that is to be described by the limited search. The value entered here is stored for recall as the initial value for this entry the next time that a search is requested.

<p>ANTENNA SEARCH</p> <p>Maximum cone angle 10°</p>

After entry of the maximum cone angle, the CDU instructs the station to commence a limited search, centered on the current elevation and azimuth angles with signal strength and cone search angle as selected. The CDU then reverts to the idle state, displaying the general data screen.

After entry of the maximum cone angle, the CDU instructs the station to commence a limited search, centered on the current elevation and azimuth angles with signal strength and cone search angle as selected. The CDU then reverts to the idle state, displaying the general data screen.

Auto Tracking. When option 4 is pressed, the station enters the auto tracking mode. In the auto tracking mode, the system controls the antenna movement and positioning to maintain it's alignment with the radiosonde. A tick is displayed alongside this menu option if the station is already in the auto tracking mode. The CDU reverts to the idle state after selecting this option.

Manual Tracking. When option 5 is pressed, the station enters the manual tracking mode. In this mode, the antenna remains stationary unless moved by a command received from a CDU or the workstation. A tick is displayed alongside this menu option if the station is already in the manual tracking mode. The CDU reverts to the idle state after selecting this option.

Calibration. When option 6 is pressed, the CDU progresses through a number of screens, sending instructions to the station and telling the user steps to take and being taken for tracking calibration of the station.

The first screen shown is as follows:

TRACKING CALIBRATION

**Please prepare the test
signal source**

ENTER to proceed

After the user presses ENTER, the CDU sends instructions to the station to perform the following operations:

- a. Move the antenna to point to the pre-configured location of the test signal.
- b. Tune to the test signal.
- c. Enable receiver AFC.
- d. Enable auto-tracking.
- e. Sample antenna angular data for approximately 25 seconds.
- f. Evaluate tracking performance by determining average antenna angles and standard deviations.
- g. Store electrical bore sight offsets if the results are judged to be acceptable.

The CDU displays a bar graph showing the progress of the calibration operation. The entire operation aborts with an appropriate message should problems be encountered.

The CDU reverts to the idle state after completion of the calibration.

Receiver Menu Key. Pressing the “REC” key causes the CDU to display a menu of operations related to the control of the receiver as follows:

RECEIVER CONTROL	
1: Auto	4: Tune
2: Manual	5: Go Freq
3: Search	

Automatic Frequency Control On. When option 1 is pressed, the station receiver enters the Automatic Frequency Control Mode. With AFC on, the receiver controls its frequency to track the frequency of the radiosonde. A tick is displayed alongside this menu option if the receiver is already exercising AFC. The CDU reverts to the idle state after selecting this option.

Manual Frequency Control Off. When option 2 is pressed, the station receiver enters the manual frequency control mode (no AFC). With AFC off, the receiver frequency is not varied, except following appropriate instructions from the CDU or workstation. A tick is displayed alongside this menu option if the receiver is in manual frequency control mode. The CDU reverts to the idle state after selecting this option.

Receiver Search (Automatic Signal Location). Selecting option 3 causes the CDU to display a series of numerical data entry screens, after which search for the frequency of the radiosonde is launched. The first screen permits entry of the starting (lower) frequency of the search. The value entered here is stored for recall as the initial value for this entry screen the next time that a frequency search is requested.

RECEIVER SEARCH
Lower Frequency
1680.40 MHZ

Numeric entry is detailed in Receiver Control above. Range checking is implemented when ENTER is pressed. (The CDU shows a brief error message and aborts the operation if an illegal value is entered). The second screen permits entry of the ending (upper) frequency of the frequency search. As stated, the value entered here is stored for recall as the initial value for this entry screen the next time that a search is requested.

<p style="text-align: center;">RECEIVER SEARCH</p> <p style="text-align: center;">Upper Frequency</p> <p style="text-align: center;">1700.00 MHZ</p>

After entry of the Upper Frequency, the CDU displays the search screen, the receiver AFC is turned off, and the receiver is instructed to begin the frequency search operation. The screen indicates the current frequency and signal strength numerically and graphically.

<p>Freq:1684.23MHz Srch</p> <p>F: ██████████</p> <p>SIG:-75dBm</p> <p>S: ██████████</p>

Pressing the ENTER or Back keys during a search ends the search and causes the receiver to hold the last frequency. If ENTER is pressed, the CDU reverts to the idle state. If Back is pressed, the CDU reverts to the previous screen.

ENTER should be pressed if/when a suitable signal has been located to restore the CDU to the idle state.

Tune (Manual Tuning). Pressing option 4 takes the CDU to the manual tuning screen. The user may now manually change the receiver frequency, using the Up and Down direction control keys. Tuning is carried out in steps of 10 kHz, 100 kHz, 500 kHz or 1MHz. The receiver AFC may be turned off or on using the “1/AFC Off” and “2/AFC On” keys.

<p>Freq:1684.23 MHz Man</p> <p>F: ██████████</p> <p>SIG:-98dBm AFC Off</p> <p>S: ██████████</p>

Pressing ENTER takes the CDU back to the idle state. Pressing Del/Back takes the CDU back to

the previous screen.

Go to Frequency. Selecting option 5 causes the CDU to display a numerical data entry screen, which permits entry of the frequency desired to tune the receiver.

<p>RECEIVER TUNING</p> <p>Go To Frequency</p> <p>1680.00 MHz</p>

Range checking is implemented over the range 1668.40MHz to 1700.00MHz. When ENTER is pressed, AFC is turned off (if it was on), the receiver frequency is changed and the CDU reverts to the idle state.

System Menu Key. Pressing of the “SYS” key causes the CDU to display a menu of options to specify the operation and configuration of the CDU.

<p>CDU CONTROL MENU</p>	
<p>1: Data</p>	<p>4: Volume</p>
<p>2: LCD</p>	<p>5: Master</p>
<p>3: Audio</p>	<p>6: Version</p>

Data. When option 1 is pressed, the CDU displays a level 2 menu screen as follows:

<p>DATA DISPLAY</p> <p>1: General</p> <p>2: STATUS</p> <p>3: Position</p>

General Display. When option 1 is pressed, the CDU reverts to the idle state, and displays the general data screen. The general data screen reports antenna angles, tracking errors, receiver frequency, signal strength, and antenna and receiver status indicators (e.g., Man, Track, Search, AFC, Scan, Squelch) as follows:

Az: 284.57°	Err:026>
EI: 007.29°	Err: 018^
F :1678.34	SIG: -102
Ant: Man	Rx: AFC

Status Display. When option 2 is pressed, the CDU reverts to the idle state and displays the status data screen whenever it is in this state. The status data screen reports LRU post status, SCA input voltage and current as follows:

SYSTEM STATUS
Faults: None
VOLTAGE: 23.6V
Current: 4.7A

Position Display. When option 3 is pressed, the CDU reverts to the idle state and displays the position data screen whenever it is in this state.

STATION LOCATION
Lat : 03218'37.8"S Long:
01844'07.2"E
ALT : 356M

LCD Contrast. When option 2 is pressed, the CDU displays a screen which the user uses to adjust the contrast of the LCD display as follows:

AUDIO OUTPUTS
1:Tuning Aid
2: FM

Note that the CDU either outputs a “Tuning Aid” or the received FM signal. The currently selected output will have a 'tick' next to it.

Volume Level. When option 4 is pressed, the CDU displays a screen which the user uses to adjust the volume of the audio output as follows:

VOLUME CONTROL
V: [REDACTED]
+ : Increase
- : DECREASE

A continuous sample tone is generated during this operation. Pressing ENTER takes the CDU back to the idle state.

Master Control. (This option will only be displayed and available for selection if the CDU being used is the Local CDU). When option 5 is pressed, the station toggles Local CDU Master Control on or off. The CDU reverts to the idle state after selecting this option. When the station is in Master Control mode, only the Local CDU may control antenna movements.

Version Information. When option 6 is pressed (option 5 if master control is not available), the CDU displays the manufacturer, the CDU location (type), the firmware version information and a copyright notice.

INTERMET SYSTEMS
LAUNCH AREA CDU
V3.21 ©2002

Pressing ENTER takes the CDU back to the idle state.

Intermediate and Error Screens. Should a requested operation require a command to be sent to the tracking station, the CDU displays the following screen:

Waiting for response
From system...

Should the system not respond as expected, error screens are displayed. If no response is obtained, the following screen is displayed:

<p>*** ERROR *** System does not Respond!</p>
--

If a requested operation resulted in an error response, it is displayed as follows:

<p>*** ERROR *** Error #xx Descriptive Message</p>

The error where the number will be one of those as defined in Table B-7.

TABLE B-7 – CDU Error Messages

Error Number	Descriptive Message	Reason
00	Bad Checksum	Unlikely to occur. May be a result of noise.
01	Bad Numerical Value	Unlikely to occur. May be a result of noise.
02	AFC On	Attempt to manually tune receiver while AFC is enabled.
03	Auto Tracking On	Attempt to move antenna while automatic tracking is enabled.
04	Destination Unknown	Unlikely to occur. May be a result of noise.
05	Invalid Operation	Attempt to change to an unobtainable antenna position or receiver frequency (e.g., in relative movements).
06	Operation Locked Out	Local CDU has locked out this operation.
07	Internal Comms Error	Unlikely to occur except if internal LRUs are faulty.

08	BIT In Progress	System busy with off-line tests. Operation is unavailable at this time.
09	Unknown command	Unlikely to occur. May be a result of noise.
10	Command Format	Unlikely to occur. May be a result of noise.
12	Busy Initializing	System is busy with initialization.
13	Busy Warming Up	System is busy with warm up operations.
14	Busy Calibrating	System is busy with tracking offset calibration.
60	Busy Moving	Antenna movement is currently in progress. Re-attempt the command once movement has ceased.
61	Motor Fault	Control of this motor is not available. Refer to POST results.
62	Motor over-current	Motor is experiencing an over-current. Investigate and rectify the situation.
63	Search in Progress	Antenna movement is not permitted while a search is in progress

4.5 Climate Control. The rack group contains commercial off-the-shelf (COTS) hardware which is not suited for the environment required for the entire antenna. These COTS systems are the Antenna DCE, +24 VDC power supply module within the power supply assembly, the UPS and the local area intercom. These units are placed in (or on, in the case of the local area intercom) the 19" rack to protect them from the temperature and humidity extremes. The climate control for the 19" rack consists of the heaters and the air conditioner.

4.5.1 Environment. The climate control equipment is designed to reduce the extremes of temperature and humidity from the required -5°C to $+5^{\circ}\text{C}$ and 0% to 100% relative humidity dome ambient to 0°C to $+4^{\circ}\text{C}$ and 0% to 95% relative humidity. The thermostats for the heaters and air conditioner are set at the factory to 40°F (4.4°C) for the heaters and 35°C (95°F) for the air conditioner.

4.5.2 Circulation Fans. There are two fans within the air conditioner. The circulation fan runs whenever power is applied. This is the main air circulation within the rack group. The compressor fan only runs when the thermostat demands cooling. There is a fan for each of the heaters. They run only when their thermostat demands heating.

4.6 Power Supply. Power is applied to the antenna at all times. Even while in the standby condition, power is applied to several functions at all times. These are the UPS for battery charge maintenance, the antenna DCE for communications and, of course, the environmental control of the air conditioner and heaters. Power to the antenna and receiver is applied by turn-on of the UPS.

If power cannot be applied to the climate control equipment, all systems are to be kept in their non-powered state until the ambient temperature and humidity within the rack group has returned to within the required values described in section 4.5.1.

The antenna can be switched from its standby condition to fully operational by two different methods depending on the location of the operator. Figure B-17 shows a block diagram of the power control for the TRS.

The operation is as follows:

- a. AC power is applied through the circuit breaker within the power supply assembly LRU.
- b. With the circuit breaker on, dome AC power is applied to the heaters, the air conditioner, the UPS and the antenna DCE.
- c. To power the entire antenna, push the on/off button on the face of the UPS if inside the dome or send the proper command to the UPS from the workstation if inside the workstation unit area.
- d. Conditioned/protected power is then applied to the antenna DCE, the SPS and the +24 VDC power supply module within the power supply assembly LRU. This then also applies the +24 VDC to the remainder of the antenna assembly.

- e. The UPS then provides for at least 10 minutes of power for an observation upon loss of the dome AC power.
- f. Shut down the antenna functions after an observation by pushing the on/off button on the face of the UPS if inside the dome or send the proper command to the UPS from the workstation if inside the workstation unit area.

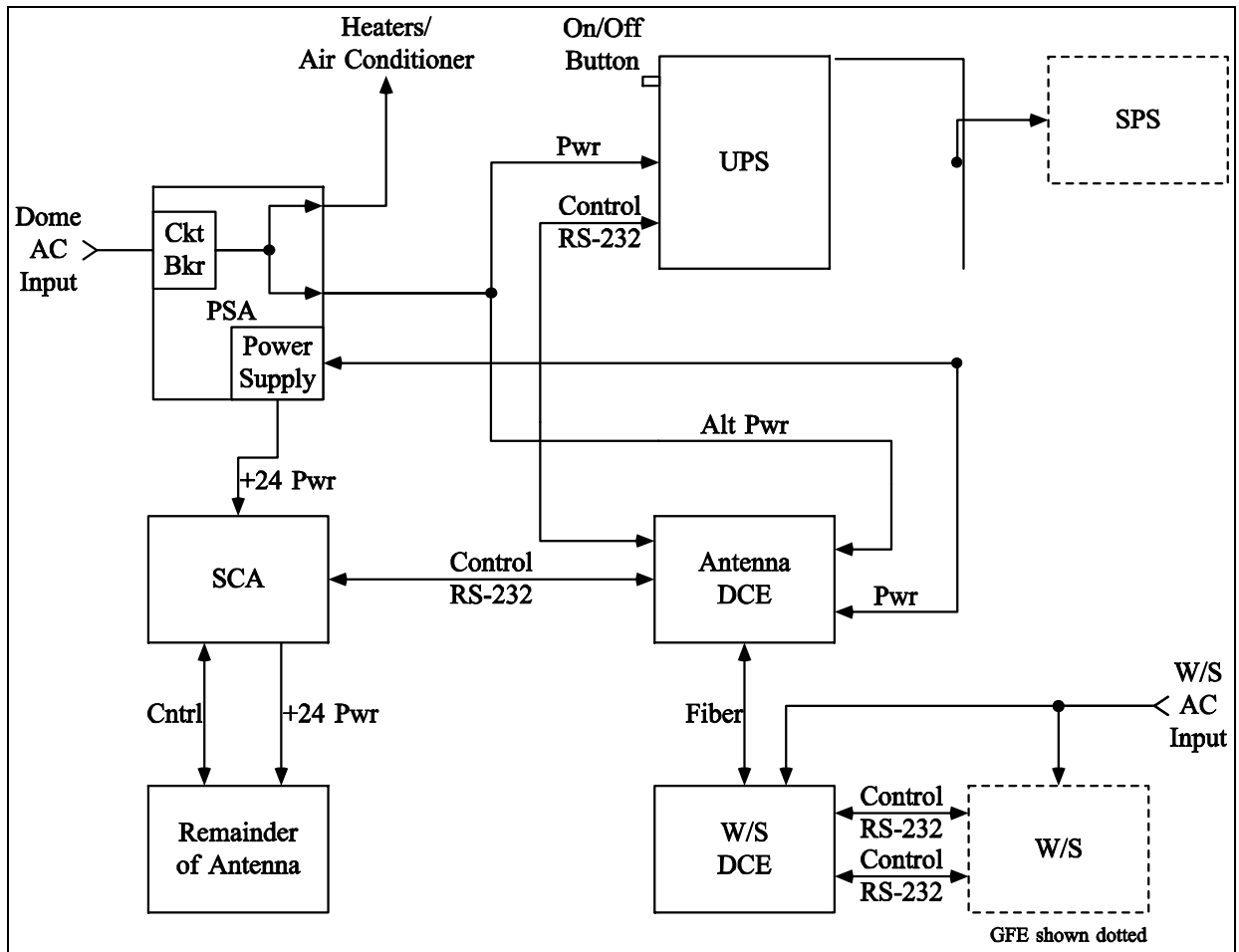

Figure B-17 – Diagram of TRS Power Control

4.7 Communications. All digital communications between the dome and the workstation; voice from the launch area CDU and/or the local area CDU to the workstation are provided by the antenna DCE and the workstation DCE working together. These communications are monitored and controlled by the workstation.

There are two digital communications ports required for the complete operation of the TRS. There is one digital port required for the operation of the SPS. This leaves three spare ports available for other systems. The spares are configured and controlled through the workstation for

other systems as required. The default configuration of the six ports are shown in Table B-8. Status monitoring and control are provided by the workstation.

CHANNEL:	1:1	1:2	2:1	2:2	3:1	3:2
PARAMATER	VALUE	VALUE	VALUE	VALUE	VALUE	VALUE
SPEED	19.2 KBPS ¹	19.2 KBPS ¹	2.4 KBPS ¹	9.6 KBPS ¹	9.6 KBPS ¹	9.6 KBPS ¹
PROTOCOL	ASYNC	ASYNC	ASYNC	ASYNC	ASYNC	ASYNC
ASYNC_ DATA	8BITS	8BITS	8BITS	8BITS	8BITS	8BITS
TIMING	DCE	DCE	DCE	DCE	DCE	DCE
CTRL_SIG	LOCAL	LOCAL	LOCAL	LOCAL	LOCAL	LOCAL
CTS	=RTS	=RTS	=RTS	=RTS	=RTS	=RTS
RTS_CTS_DEL	MIN	MIN	MIN	MIN	MIN	MIN
V.54_ EMUL	DCE-DCE	DCE-DCE	DCE-DCE	DCE-DCE	DCE-DCE	DCE-DCE
DSR_ MODE	ON	ON	ON	ON	ON	

Table B-8: Configuration Data from the DCE IDD

Note: Serial ports 1:1 and 1:2 are used by the antenna/receiver status monitoring and control and SPS channels respectively. They are required to operate at the listed 19.2 Kilobites Per Second (KBPS). Serial port 2:1 is used by the UPS to control the state of its output voltages to ON or OFF. Serial ports 2:2 through 3:2 are spares for future RS-232 asynchronous port usage expansion including surface observing instruments. They are set by default to 9.6 KBPS. The baud rate for a spare channel to be used is changed to that required by the specific expansion port interfaces. The ranges of standard baud rates available for the spare channels are from 300 to 38,400 baud.

APPENDIX C - BALLOON FAMILIARIZATION

<u>Table of Contents:</u>	<u>Page</u>
1. Introduction.....	C-1
2. NWS Balloon Types	C-1
2.1 Routine Upper-Air Observations.....	C-1
2.2 Severe Weather Upper-Air Observations	C-2
3. Observation Performance.....	C-2
4. Balloon Storage and Preparation	C-3
5. Balloon Conditioning.....	C-3
6. Inflation Gases	C-4

1. Introduction. The success of the radiosonde observation depends upon the performance of the lighter than air gas filled balloon. The balloon lifts the radiosonde at a predetermined rate of ascent through the troposphere and stratosphere for periods typically lasting from 90 to 150 minutes.

2. NWS Balloon Types. Radiosonde balloons are spherically shaped films of natural latex or synthetic rubber which, when inflated with helium or hydrogen gas are used to transport the radiosonde into the upper atmosphere. The skin of these balloons is extremely thin, except at the neck. When inflated, the wall of the balloon ranges in thickness from 0.051 to 0.102 mm at sea level to 0.0025 mm at typical bursting altitudes of 30 km or higher. Additionally, the balloon expands in size from an approximate release diameter of 1.85 m to an expanded diameter of up to 10 meters at burst altitude. Considering these dimensions, it is obvious that the smallest cut, bruise, abrasion, scratch, or undue strain the balloon may sustain during pre-observation preparations is likely to cause the balloon to burst prematurely at a lower altitude than it routinely attains.

2.1 Routine Upper-Air Observations. The NWS routinely uses general purpose (GP) balloons rated to achieve burst heights of 26 kilometers or higher. These balloons are used under all weather conditions. These balloons are thin skinned and are light weight to reduce the required volume of inflation gas needed to maintain proper ascension rates.

Ascent rates should average between 275 - 350 meters per minute throughout the observation. Observations with ascent rates of 250 meters per minute or less will likely result with under-inflation or possibly a leaking balloon. Observations with ascent rates of 500 meters per minute or higher should be checked closely for a possible leaking or failed pressure sensor. If a leaking or a failed pressure sensor is discovered, refer to MicroART Chapter 14 and Chapter 11 in the

RRS User's Guide for procedures on how to handle the data.

Note: The switch post for the hydrogen safety switch can become sticky, scratched or bent causing over inflation of the balloon. This may also cause high ascent rates.

2.2 Severe Weather Upper-Air Observations. When high surface winds or moderate or greater icing or heavy precipitation is expected, a higher volume of the lighter than air gas should be added to the all purpose balloons now in use. (See section 3 for more details.)

3. Balloon Performance. Balloon performance is measured by the burst altitude and ascent rate. Performance is affected by the free lift, the thickness of the balloon skin, the air mass overlying the observing site, the weather conditions to which it is exposed, and the size and shape of the balloon envelope. Since most of these factors are uncontrollable, the free lift to produce optimal performance for a given observation can best be determined by examining past balloon performance under various surface weather conditions.

INFLATION LIFT REQUIREMENTS: The amount of hydrogen, helium, or natural gas most favorable for producing optimum performance should be ascertained before actual inflation of the balloon. Lift is defined as follows:

- a. **FREE LIFT:** Free lift is the number of grams of lift that are available over and above that required by a balloon to support the weight of a complete radiosonde balloon train.
- b. **NOZZLE LIFT:** Nozzle lift is the FREE LIFT plus the grams of lift required by a balloon to support the weight of a complete radiosonde train, excluding the weight of the balloon, (Radiosonde, parachute, light stick, dereeler or train regulator, and twine).
- c. **GROSS LIFT:** Gross lift is NOZZLE LIFT plus the grams of lift required to support the weight of the balloon.

The amount of gas required for producing optimum performance is usually defined as the highest possible bursting altitude while maintaining an average ascension rate between 275 to 350 meters/minute. The balloon is to be sufficiently inflated to ensure successful launch in the surface conditions which may exist at the time. These conditions include, but are not limited to, the following:

- (1) During fair weather conditions, optimum performance will routinely be achieved with free lift ranging from 700 to 1000 grams for 26 kilometer general purpose balloons.
- (2) During periods of high winds, the balloon should be inflated with enough gas so that it will rise fast enough to clear near-by obstacles. If surface winds are greater than 25 knots, up to 300 grams of extra free lift may be needed.

- (3) Performance obtained by preceding observations may be considered in selecting a free lift value to be used.
- (4) When precipitation, icing, or terrain turbulence is occurring or expected at release time, an effort should be made to provide sufficient free lift to ensure that the balloon will not descend or float. An increased free lift of 100 grams is typically sufficient to compensate for an increase in the weight of the train resulting from light precipitation. Under light or moderate icing conditions, or moderate to heavy precipitation an increase in free lift of from 200-300 grams will usually be sufficient. Under severe icing conditions an increase of 500 grams or more may be required.

Note: It is important to remember that the lift capabilities of hydrogen and helium differ. Hydrogen, the lighter of the two gases, lifts 31.8 grams per cubic foot at sea level while helium lifts 28.2 grams per cubic foot at sea level.

4. Balloon Storage and Preparation. To ensure maximum burst height, balloons are stored and handled with care. Balloons should be stored in their original sealed containers inside the office isolated from large electric motors or generators. The ozone emitted from motors and generators causes synthetic rubber to deteriorate. Ideal temperatures for storage should be in the range of 10°C to 30°C. Temperatures below 0°C or above 40°C should be avoided during storage. Balloons will not be stored in the inflation shelter.

Balloons deteriorate with age. Therefore, they should be used in the order of their production dates to avoid excessive aging. Balloons are very delicate. No part of the balloon other than the neck will be touched with bare hands. Use soft rubber gloves, soft cotton gloves, or the plastic bag in which the balloon was wrapped when handling parts other than the neck.

As a result of exposure to relatively low temperatures and extended periods in storage, synthetic rubber balloons suffer a partial loss of elasticity through crystallization. Synthetic balloons used in this state will burst prematurely. To ensure the maximum elasticity, all neoprene balloons should be used within a year of the manufacture date of the outside of the balloon box. If an upper-air station has an electric conditioner, use the procedures in Section 5 to enhance the performance of balloons stored by accident in adverse weather conditions or one that is aged.

5. Balloon Conditioning. All balloons that are over 1 year old, or have been stored in sub-freezing temperatures, should be conditioned before they are inflated using an electric conditioner if available. Under all other conditions, the conditioning of the balloons is left to the stations.

ELECTRIC CONDITIONING METHOD: Balloons should be conditioned for no more than 72 hours. The balloon should be removed from the plastic bag, unfolded, and placed in its cardboard box to permit uniform conditioning. Do not open the neck until the inflation nozzle is to be inserted.

When the electric balloon conditioner is used, balloons will be conditioned for a minimum of 12 hours at temperatures ranging between 60°C and 65°C (140°F to 160°F) and at a relative humidity near 100%. Four balloons may be kept in the conditioner at one time.

6. Inflation Gases. Two types of gas are typically used to inflate weather balloons: hydrogen and helium gas.

HYDROGEN: Although hydrogen gas is more volatile than helium (which is non-flammable), most land-based locations use hydrogen because of less cost. The price of hydrogen is only a fraction the cost of helium. Safe practices are strictly adhered to when handling and using hydrogen. Hydrogen is either manufactured and bottled by a gas distributor or produced on site with a hydrogen generator.

HELIUM: Helium is safe and easy to use for inflating balloons. Unlike hydrogen, helium is an inert gas and does not pose a fire potential. However, helium costs are significantly higher than hydrogen.

APPENDIX D - PRE-OBSERVATION PREPARATIONS

<u>Table of Contents:</u>	<u>Page</u>
1. Introduction	D-2
2. Balloon Train Components	D-2
2.1 Balloon.....	D-2
2.2 Train Cord.....	D-3
2.3 Parachute.....	D-4
2.4 Train Regulator and Dereeler	D-5
2.5 Shock Unit	D-5
2.6 Light Stick.....	D-5
2.7 Radiosonde.....	D-6
3. Balloon Train Requirements.....	D-6
3.1 High Surface Wind	D-6
3.2 Heavy Precipitation.....	D-6
3.3 Moderate to Severe Icing.....	D-6
4. Balloon Inflation Launch Shelter (BILS) Requirements	D-6
5. Balloon Inflation.....	D-7
5.1 Safety Procedures	D-7
5.2 Proper Inflation Rates	D-8
5.3 Hydrogen Safety Switch	D-9
5.4 Inflation Procedures.....	D-11
5.4.1 First Stage of Inflation	D-11
5.4.2 Intermediate Inspection.....	D-11
5.4.3 Final Inflation	D-11
5.4.4 Securing the Balloon.....	D-11
5.5 Launch Delays	D-11
5.6 BILS System Inflation	D-12
6. Fastening the Balloon Train Together	D-12
6.1 The Initial Tying of Lines onto the Parachute and Balloon.....	D-12
6.2 Linking the Train Regulator or Dereeler to the Balloon Train.....	D-13
6.3 Tying the Balloon Train without a Parachute.....	D-13
 Figures	
D-1 Observer Tying off Balloon before Launch.....	D-3
D-2 Balloon Train during the Observation	D-4
D-3 High-Modulus Balloon Released from BILS	D-7

Figures	Page
D-4 Tying Off the Balloon.....	D-8
D-5 Gauge Measuring Hydrogen Line Pressure.....	D-9

1. Introduction. Pre-observation preparations are an integral part of ensuring a successful upper-air operation. Care taken during pre-observation decreases the chance of having unsuccessful or missed observations due to defective parts or from using improper procedures. The observer follows safety procedures that pertain to the site as indicated in Appendix K and should be observant of changing weather conditions that may affect the decision on train components used, amount of gas, and the type of release that should be attempted.

Observers should routinely look at surface weather and including the upper level wind charts and the wind profile from the Weather Service Radar (WSR)-88D display if available. Knowing this information and following proper pre-release procedures, should help increase the chances of a successful signal lock-on and observation.

2. Balloon Train Components.

2.1 Balloon. The upper-air balloons are properly inflated, tied, and secured before other train components are fastened onto the train cord. Before the balloon is removed from the inflation nozzle, close the cylinder valve to shut-off the gas from the cylinder. Release the remaining gas in the line by pulling the switching column down and then tie the balloon neck shut (See Figures D-1 and D-4). Remove the balloon from the nozzle. Secure the balloon inside the inflation shelter by tying it to a hook or the measuring weights. Next, carefully fold the balloon neck upward and tie with a square knot. See Appendix C for information on balloon type and proper procedures for balloon storage, handling, and conditioning.

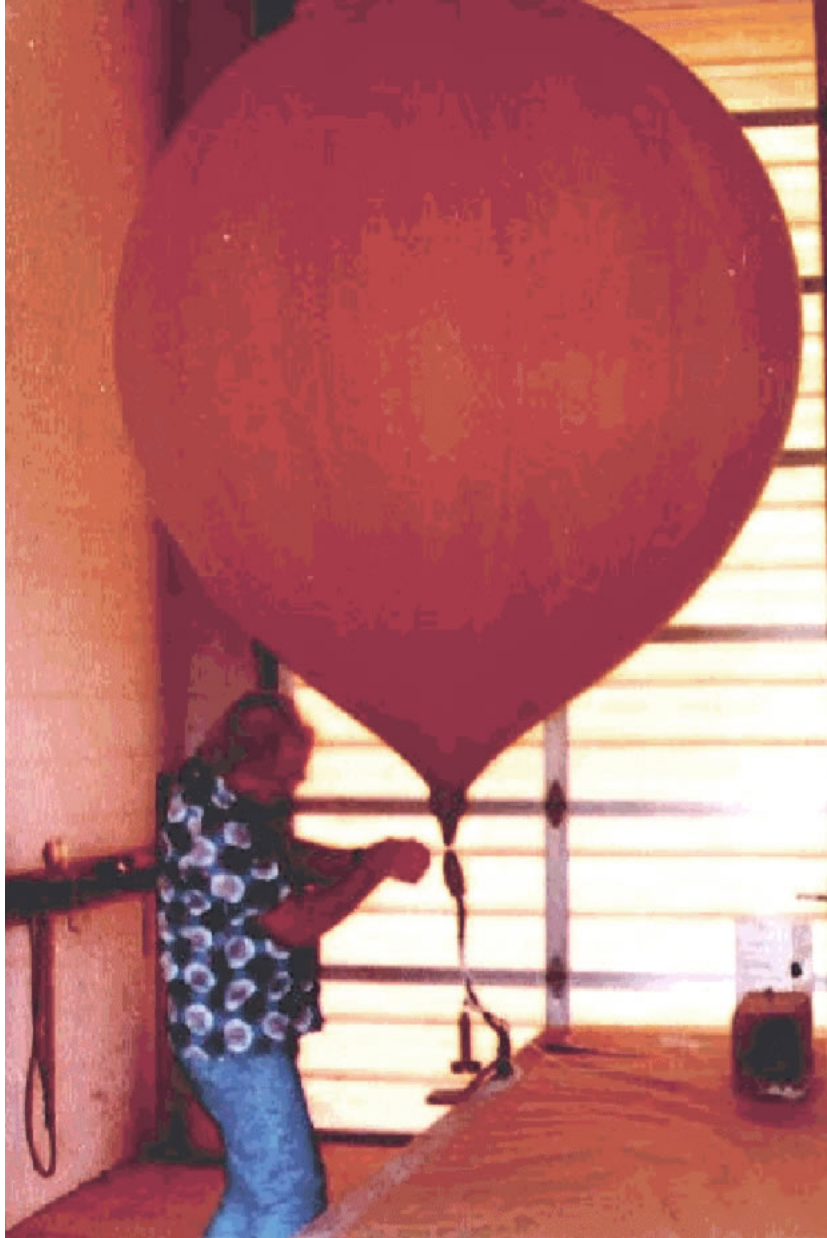

Figure D-1 - Observer Tying Off Balloon before Launch.

2.2 Train Cord. The train cord should at least be a 20-ply biodegradable string between 25 and 35 meters in length. A doubled 2 meter length of cord is needed between the neck of the balloon and the parachute. The remaining train length will be a single 20-ply string tied from the bottom of the parachute to the radiosonde.

Use a train length of 25 to 35 meters under routine conditions. Trains of less than 25 meters in length should never be used. Short trains increase the risk of the radiosonde being too close to the radiation environment of the balloon or of encountering the balloon's wake as it ascends

thereby placing the radiosonde in a disturbed and unnatural atmosphere. Erroneous temperatures and relative humidity may result.



Figure D-2 - Balloon Train during the Observation

2.3 Parachute. Parachutes will be used at all stations unless NWS Headquarters issues a station waiver. Parachutes are opened and carefully inspected before attaching it to the flight train. Reject the parachute if it is torn, has missing strings or shows failed glue joints. Report defects to NWS Headquarters. The color of the parachute is bright orange that can be distinguished from the sky background during daytime operations. The parachutes are designed so that the train falls at a rate 10 m/s (22 Miles Per Hour (mph)) or slower by the time it reaches the ground.

If a waiver has been approved by NWS Headquarters, parachutes may be optional at remote stations where:

- a. Risk of injury is virtually non-existent, and;
- b. Risk of property damage is very negligible.

Note: At stations that inflate balloons with helium gas, the warning card attached to the base of the parachute will be removed and discarded.

2.4 Train Regulator and Dereeler. During surface high winds, observers may be required to use a train regulator or dereeler. Train regulators and dereelers enable the observer to launch an instrument without having to contend with many yards of slack twine or having to chase the balloon to release the radiosonde. Use 2 meters of doubled cord between the neck of the balloon and the parachute. Next tie the ring or loop at the top of the radiosonde to the free end of the train regulator or dereeler.

When a train regulator is used, the balloon is held in one hand and the train regulator and radiosonde are held in the other. The train regulator is held in such a way that neither the weight of the radiosonde nor the lift of the balloon unwinds the cord until release. At launch, the balloon is released and almost simultaneously, the radiosonde is released. As the balloon rises, the weight of the radiosonde causes the cord to slowly unwind from the train regulator or dereeler.

Follow instructions attached to the particular train regulator or dereeler in use for various weather conditions.

2.5 Shock Unit. During high winds, a shock unit may be used in the radiosonde train between the regulator and the radiosonde if vibration caused by the inconsistent unwinding of the regulator is expected to produce an unstable signal. The shock unit may be formed by tying together in parallel four 0.125 inch wide rubber bands. The rubber bands are tied to the cord of the train in such a way that the cord is slack between the ends of the bands, thereby permitting them to flex and extend when the line goes under tension. In this way, the shock unit acts as a shock absorber.

2.6 Light Stick. RDF tracking systems require the observer to visually track the radiosonde and manually adjust the antenna position to ensure the receiving system is locked onto the radiosonde's signal. This can be a challenge at night, in poor visibility if the radiosonde trajectory is expected to experience large changes in direction just after release. (e.g fog, low clouds)

When visibility is restricted or at night, the observer should ensure a lighting unit is attached to the train to facilitate visual tracking of the balloon for the early part of the observation. The lighting unit will also help the observer relocate a balloon train higher in the ascent if the receiving system has lost the main signal.

The lighting unit intensity should be such that the radiosonde's position can be distinguished from the background for at least five minutes. The National Logistics Supply Center (NLSC) stocks various colored light sticks that will function for 30 minutes or longer. Care is taken to ensure that the lighting unit will not interfere with the train regulator or dereeler. This can be successfully accomplished by tying the light unit near the balloon neck with little slack to keep the light stick from swinging in the wind.

Light sticks will also be used around airports at night and during low light conditions to allow aircraft the opportunity to visually sight and possibly avoid the balloon train.

2.7 Radiosonde. The radiosonde is tied to the balloon train so that it holds the lowest position in the train. See Appendix A for information on NWS radiosonde types, performance, and operational requirements.

3. Balloon Train Requirements.

3.1 High Surface Wind. Under high wind, (more than 25 knots) a train regulator or dereeler may be required. See sections 2.4 and 2.5 for more information. The balloon should also be inflated to attain a nozzle lift that is 10% to 20% greater than fair weather launches.

Launches in very high wind conditions (more than 40 knots) pose special problems in protecting the balloon train equipment until it becomes airborne. The balloon should be inflated to attain a nozzle lift that is 20% to 30% greater than during fair weather launches (see Appendix C, sections 3 and 4), along with a train regulator or dereeler. The observer may fasten a shock unit (see Section 2.5) between the regulator and the parachute to dampen vibrations that could impair data telemetry from the radiosonde. Assistance from other personnel should be considered to avoid obstructions and to ensure a successful launch.

3.2 Heavy Precipitation. The observer should attach a light stick to visually improve locating the radiosonde after release to allow manual adjustment of the tracking antenna. The balloon should be inflated to attain a nozzle lift that is 10% to 30% greater than used during fair weather launches. See Appendix C section 3.

3.3 Moderate to Severe Icing. When moderate to severe icing is anticipated the observer should increase nozzle lift (See Appendix C Section 3). A standard rule of thumb should be to increase the nozzle lift by 300 grams when moderate icing may be anticipated and 500 grams or more when severe icing is expected.

4. Balloon Inflation Launch Shelter (BILS) Requirements. Because some BILS are located in areas having a restricted or confined release area plus the hatch opening of the BILS being of limited size, a train regulator or dereeler is required for nearly all launches. The train regulator or dereeler allows the balloon train to exit the launch shelter without becoming entangled or striking objects.



Figure D-3 - High-Modulus Balloon Released from BILS

5. Balloon Inflation. The balloon inflation will begin no more than 45 minutes prior to release. All safety procedures will be followed.

5.1 Safety Procedures. Place the balloon where it will not come into contact with sharp objects or rough surfaces. If the dimensions of the inflation shelter permit, the balloon should be placed on a table for inflation. The table top should be smooth, free from projections and have all edges rounded. The table top should be cleaned frequently. To reduce abrasion during inflation, the table should be large enough so the balloon can be fully extended before the inflation is started. If it is not practical to use a table, the balloon should be placed on a clean surface with all objects that have sharp points removed from the immediate vicinity of the balloon.

Place the inflation nozzle in the neck of the balloon and secure it with a clamp, soft cord, or other suitable device which won't damage the balloon (See Figure D-4).

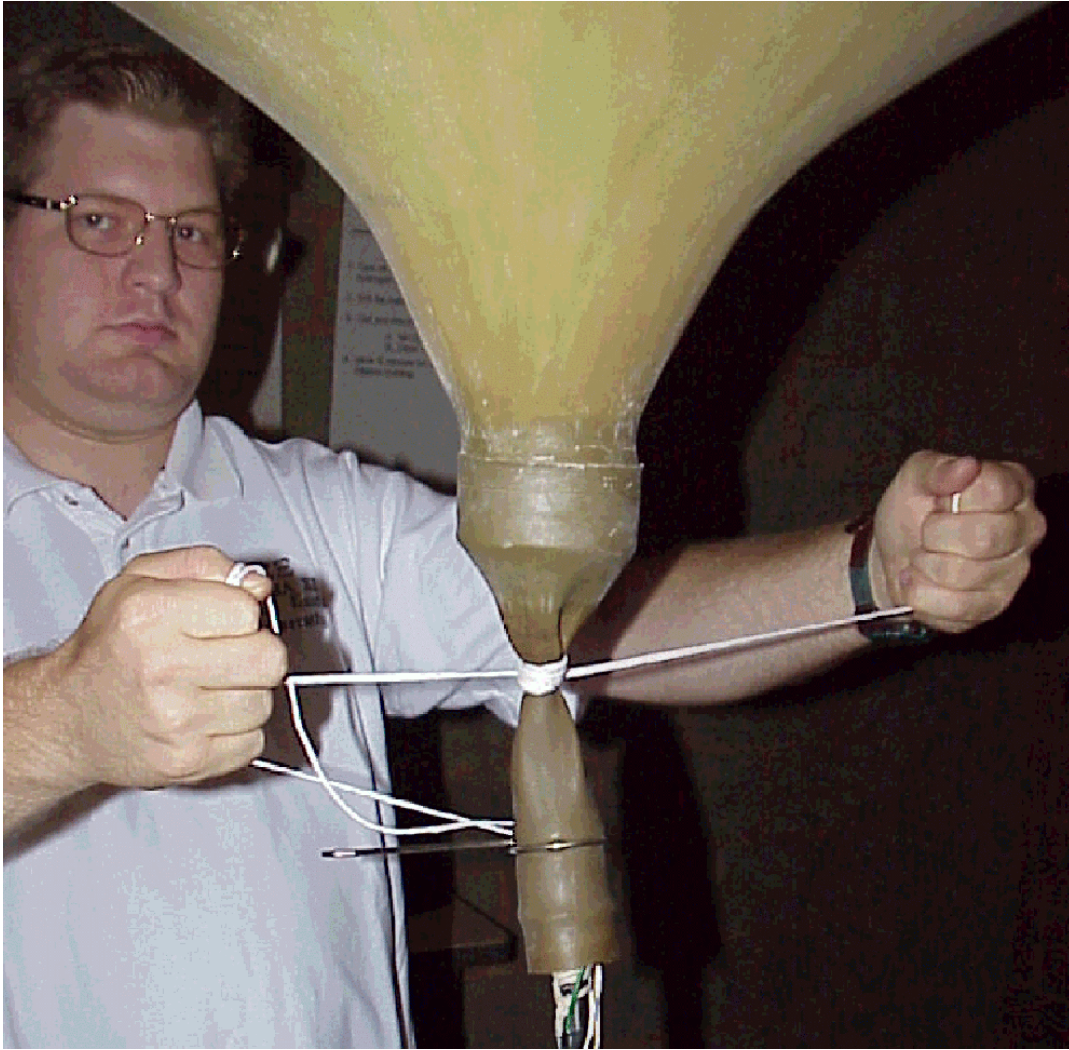

Figure D-4 - Tying Off the Balloon

5.2 Proper Inflation Rates. **HYDROGEN:** When hydrogen is used, open the valve to a pressure not exceeding 15 Pounds Per Square Inch (psi) (See Figure D-5). Inflation should take no less than 7 minutes. If the balloon is rapidly inflated with hydrogen gas the likelihood of generation of static electricity is greatly increased and with it, the hazard of a fire or an explosion.



Figure D-5 - Gauge Measuring Hydrogen Line Pressure

HELIUM: When using helium, inflate the balloon at a sufficiently slow rate to ensure uniform expansion. If the gas regulator or outlet valve is equipped with a low pressure outlet gauge, open the valve to a pressure not exceeding 20 psi. When a low pressure outlet gauge is not available adjust the flow of gas so a minimum of 7 minutes are required to inflate the balloon completely.

NATURAL GAS: The same precautions mentioned for the use of hydrogen apply to the use of natural gas.

5.3 Hydrogen Safety Switch. There are two methods for inflating balloons using the hydrogen safety switch. Method I allows the observer to stay outside the inflation building while the balloon is inflated. Method II allows the observer to stay inside the inflation building. Either method may be used at the discretion of the observer.

HYDROGEN INFLATION METHOD I

To implement method one, proceed as follows:

- a. Be sure the valve on the hydrogen tank is closed.
- b. Be sure the power switch on the control box is OFF.
- c. Connect the balloon neck to the inflation nozzle in accordance with established procedures.
- d. Be sure the rotating latch is in the lower rest position.
- e. Align the rotating latch with the oval-shaped hole so that it is free to rise to the upper limit of travel.

- f. Open the valve on the hydrogen tank.
- g. Throw the power switch on the control box to the ON position.
- h. Set the regulator to provide the prescribed pressure: 15 psi.
- i. Depress the start switch on the control box to initiate the flow of hydrogen. The opening of the solenoid valve is indicated by a lighted indicator lamp on the control box. Continue to hold the start switch in its actuated position until the balloon has attained sufficient buoyancy to raise the rotating latch to the upper limit of travel. When this occurs, be sure that the rotating latch is aligned with the oval-shaped hole in order to retain the safety feature of the hydrogen switch. This alignment will permit the rotating latch to drop to the lower rest position if a balloon bursts during inflation. This action automatically cuts off the flow of hydrogen.
- j. Release the start button. Inflation will continue until the balloon has reached its predetermined lift. At this time, the balloon will rise and lift the switching column from the rest position. In so doing, it will cause the lower reed switch in the switch post to open. This action deactivates the solenoid switch and cuts off the flow of hydrogen.
- k. Turn off the valve on the hydrogen tank.
- l. Pull the switching column down on the switch post momentarily to the rest position. This will open the solenoid valve and relieve the pressure in the inflation hose between the hydrogen tank and the solenoid valve.
- m. Turn the power switch on the control box to the OFF position.
- n. Tie off the neck of the inflated balloon in accordance with existing instructions (see Section 5.4.4).

HYDROGEN INFLATION METHOD II

Method II assumes the same procedures as Method I, except steps i and j are replaced with the following three steps.

Using this method, gas flow is initiated by raising the rotating latch from the lower rest position to the upper rest position. With the rotating latch locked in the raised position, it is not necessary to depress the start switch at any time in the inflation cycle. Inflation will continue as in method one until the balloon has attained sufficient buoyancy to lift the switching column on the switch post.

Proceed as follows:

- a. Raise the rotating latch to the limits of travel and lock it into the UP position. This action will initiate the flow of hydrogen into the balloon.
- b. After the balloon has attained sufficient buoyancy to hold the rotating latch at its upper limit of travel, realign the latch with the oval-shaped hole in order to retain the safety features of the hydrogen switch.
- c. Inflation will continue until the balloon has attained sufficient buoyancy to lift the switching column from the rest position on the cover of the junction box. In so doing, it will cause the lower reed switch to open. This action deactivates the solenoid switch and cuts off the flow of hydrogen.

5.4 Inflation Procedures.

5.4.1 First Stage of Inflation. When the balloon has been prepared and inflation equipment (cylinders, hoses, clamps, safety switches) are confirmed to be in good order, begin the inflation of the balloon in accordance with guidelines stated in section 5.3.

5.4.2 Intermediate Inspection. When the balloon is about one-half inflated, close the gas valve. Listen for gas leaks and examine the balloon for defects. Serious defects may result from foreign materials in the balloon, a break in the balloon skin, or a deformity in a small area of the balloon film. Discoloration should not be regarded as a defect unless experience indicates that certain types of discolorations result in premature bursting. If the balloon is defective, reject it and begin inflating a second balloon. Otherwise, proceed with inflation.

5.4.3 Final Inflation. Once the balloon is at least partially inflated check to ensure the balloon is not in contact with the ceiling of the inflation shelter or other surface. If the balloon is likely to touch the ceiling before the desired lift has been reached, proceed carefully with the inflation and secure the balloon in a manner to minimize or eliminate possible contact with the ceiling or other objects. Sites having low ceilings should use padding or netting to ensure the ceiling is smooth so damage to the balloon will not occur.

5.4.4 Securing the Balloon. Tie the neck of the balloon with a two meter length of doubled cord as soon as inflation is completed. Make one turn of the cord around the neck of the balloon near the center (close to the top of the inflation nozzle). Pull the cord as tightly as possible and tie with a knot. Make another turn around the neck and tie again (see figure D-4). Remove the balloon from the nozzle, fold the neck upward and again tie the neck just above the first knot. Be sure that all cord is below the area where the neck starts to flare out to join the envelope of the balloon. The balloon should be left in the inflation shelter until preparations for the release have been completed.

5.5 Launch Delays. Balloon inflation will not occur earlier than 45 minutes prior to release. Allowing the balloon to be inflated an extended period of time before the launch causes undue strain on the balloon and is likely to cause premature bursting. At sites using helium, the balloon

may be allowed to rest against the ceiling of the inflation room provided the ceiling is smooth and free from projections or rough spots. Balloons inflated with hydrogen or natural gas will not rest against surfaces other than an anti-static balloon cover or shroud once removed from the inflation nozzle.

5.6 BILS System Inflation. Inflation at sites using a BILS is slightly different. The BILS sites use a gas meter to fill the balloon with the appropriate amount of helium. The amount will range from 65 to 85 cubic feet. The observer is required to manually shut the valve off once the desired cubic feet of helium have been placed in the balloon.

6. Fastening the Balloon Train Together. Whenever possible, the station workload should be arranged so that release can be made within a few minutes following the testing and calibration of the radiosonde. The balloon train should be completely assembled and ready for launch within 20 minutes from the time the battery cell was activated. The train is usually assembled during the balloon inflation process which is performed 30 to 45 minutes prior to release. The train assembly at the time of launch should be avoided and should only be done if the observer is sure that launch will occur within 20 minutes of battery activation time.

Proper assembly of train (i.e., the balloon, parachute, radiosonde, and launching devices which may be used) is critical to the success of the observation and the accuracy of the data. Improper train assembly could result in:

- a. Undue strain on the balloon neck and premature termination of the observation.
- b. Unrepresentative measurement of the atmosphere.
- c. Entanglement of balloon train components.
- d. Higher risk of collision with ground based obstacles.
- e. An increased hazard when the train descends and the parachute doesn't deploy.

6.1 The Initial Tying of Lines onto the Parachute and Balloon.

- a. Tie a 2 meter length of double strand 20-ply cord to the top of the **parachute**. Leave free the other end of this cord. (If a parachute is not required, see Section 6.3 for instructions.)
- b. Follow procedures outlined in Section .5.4.4 on securing the balloon.
- c. If a shock unit is necessary, see Section 2.5 for a description.

6.2 Linking the Train Regulator or Dereeler to the Balloon Train. When a train regulator is to be used follow these procedures:

- a. Tie the train regulator or dereeler to the lower end of the parachute. Care is exercised when using a dereeler to ensure that the dereeler is secured properly.
- b. If a parachute is not required, ensure the doubled-cord is secured firmly around the **train regulator's** spindle (axle). If a dereeler is used, it should be secured to the balloon by placing the dereeler handle in the fold of the neck of the balloon and secured firmly with several knots to ensure the handle can not slip out.

6.3 Tying the Balloon Train without a Parachute. The final phase of the balloon train assembly is to link the train assembly to the balloon. The assembly is dependent on the train's configuration.

- a. For observations that require **neither a parachute nor a train regulator/dereeler**: Follow the instructions in Section 5.4.4. Fasten the free end of the 2 meter doubled cord to a 25-35 meter length of single 20-ply cord with the free end attached to the radiosonde.
- b. For observations that require a **dereeler** but no parachute: Follow the instruction in section 5.4.4, but place the handle of the **dereeler** at the point on the neck of the balloon where the original knot was tied and then fold the neck up and secure the dereeler by wrapping several turns of the doubled cord around the dereeler hook or arm and tying a tight knot. Release the suspension string from the slot of the dereeler and tie to the metal eyelet on the top of the instrument.
- c. For observations that require a **train regulator** but no parachute: Fasten a 2 meter -length of doubled-cord to the balloon's neck following procedures shown in section 5.4.4. Then secure the end of the remaining amount of doubled-cord to the **train regulator**. The line from the train regulator should then be tested by firmly pulling a small length of line from the regulator and attaching it to the radiosondes eyelet.

APPENDIX E - LAUNCHING PROCEDURES

<u>Table of Contents:</u>	<u>Page</u>
1 Introduction.....	E-3
2. Synoptic Schedule Requirement.....	E-3
3. Non-Synoptic Observations.....	E-4
4. Overall Pre-Launch Sequence.....	E-4
5. Equipment Warm-up.....	E-9
5.1 RDF Tracking Equipment Warm-up.....	E-9
5.2 RRS Tracking Equipment Warm-up.....	E-9
6. Preparing for Antenna Orientation.....	E-9
6.1 RDF Antenna Orientation.....	E-10
6.2 RRS Antenna Orientation.....	E-10
7. Obtaining Status Check and Orientation.....	E-10
7.1 RDF Equipment Checks.....	E-10
7.2 RRS Hardware Status Checks.....	E-10
8. Enter Pre-Release Data into MicroART.....	E-10
8.1 Administrative, Equipment, and Radiosonde Data.....	E-10
8.2 Surface Observation at Release Site.....	E-10
8.2.1 Pressure.....	E-11
8.2.2 Temperature.....	E-11
8.2.3 Dew Point.....	E-11
8.2.4 Wind Direction and Speed.....	E-11
8.2.5 Clouds and Weather.....	E-11
8.3 Check the Radiosonde Sensor Accuracy.....	E-12
9. Baselining the Radiosonde.....	E-13
9.1 Baselining the RDF Radiosonde.....	E-13
9.2 Baselining the GPS Radiosonde.....	E-14
10. Transportation of Instrument to Release Site.....	E-14
11. Final Inspection of Balloon Train.....	E-15
12. Final Safety Check.....	E-15
12.1 Notify the Local FAA Tower.....	E-16

<u>Table of Contents:</u>	<u>Page</u>
12.2 More than 5 Nautical Miles from a Controlled Airport or at a Non-Controlled Airport.....	E-16
13. Radiosonde Launch Procedures.....	E-16
13.1 RDF Radiosondes	E-16
13.1.1 Fair Weather Launches	E-18
13.1.2 Calm Wind Launches.....	E-18
13.2 GPS Radiosonde Launches.....	E-18
13.2.1 Launches Using the RRS Workstation	E-18
13.2.2 Launches Using the RCDU	E-19
13.3 Foul Weather Launches	E-20
13.3.1 Heavy Precipitation.....	E-20
13.3.2 Freezing Precipitation	E-21
13.3.3 High Winds	E-21
13.3.4 Two-Person Technique	E-21
13.3.5 Thunderstorms	E-21
13.4 Delayed Release.....	E-22
13.5 Operation of the RDF Remote Release Timer Switch.....	E-22
14. Maintaining Proper Signal Lock-On.....	E-22
15. Antenna Tracking Modes.....	E-24
15.1 RDF Antenna Tracking Modes.....	E-24
15.2 RRS Antenna Tracking Modes	E-25
15.3 Receiver Searching Modes	E-26
15.3.1 RDF Receiver Search Modes.....	E-26
15.3.1.1 Limited Search Mode.....	E-26
15.3.1.2 Full Search Mode.....	E-26
15.3.1.3 Manual Search Mode.....	E-26
15.3.2 RRS Receiver Search Modes.....	E-27
15.3.2.1 Manual Search Mode.....	E-27
15.3.2.2 Auto Search Mode	E-29
16. Successful Release Criteria.....	E-29
16.1 MicroART Observation	E-29
16.2 RRS Observation	E-30
17. Multiple Releases.....	E-30
17.1 The Second Release	E-30
17.2 The Third Release	E-31
18. Observation Success	E-31

<u>Table of Contents:</u>	<u>Page</u>
19. Reasons for Missing Data.....	E-32
19.1 Weak Signal.....	E-32
19.2 Interference.....	E-32
19.3 Sensor Failure.....	E-32
19.4 Other Causes.....	E-32
19.5 Successful Observation - Some Missing Data.....	E-32
19.6 Unsuccessful Observation - Sum of All Missing Data.....	E-32
20. Unscheduled Observations.....	E-33
21. Missed Observations.....	E-33

Figures

E-1 Open Remote Control Panel.....	E-24
E-2 Console Display Unit (CDU).....	E-28
E-3 Receiver Display.....	E-28

Tables

E-1 Sequence Actions Prior to Launch for RDF.....	E-5
E-2 Sequence Actions Prior to Launch for GPS.....	E-6
E-3 Observation Check List for RRS.....	E-8
E-4 Post Observation Check List for RRS.....	E-9
E-5 Termination Due to Missing Temperature Data.....	E-32

1. Introduction. This appendix pertains to the sequence of events for balloon launch. Some minor modifications to the procedures may occur, but the sequence of events should remain basically as outlined. These procedures and instructions provided in the MicroART or RRS Training Guide should provide the observer with enough guidance to successfully prepare and launch the radiosonde.

2. Synoptic Schedule Requirement. The standard times for scheduled synoptic observations are 0000 UTC and 1200 UTC. Release times should be scheduled as close as conditions permit to 2300 UTC and 1100 UTC, but never earlier.

Delayed synoptic releases are usually due to radiosonde or ground equipment problems or when a 2nd release is required. Releases may be made after the standard times of observation, but no later than 0029 UTC and 1229 UTC. This schedule ensures the upper air observational data are available to initialize the 0000 UTC and 1200 UTC numerical weather prediction models. The major actions required for a successful release are outlined in Tables E-1 and E-2.

The actual time of release is expressed in hours and minutes UTC and is automatically recorded to the nearest minute for use in the “TTBB” coded message in MicroART and in all coded

messages using RRS software.

3. Non-Synoptic Observations. For all non-standard observation times the release window, in regard to the recorded time of the observation, is from 30 minutes before to 29 minutes after the hour of assigned observation time. Ex: release at 0231 UTC would be for the 0300 UTC observation, a launch at 0510 UTC would be for the 05 UTC observation.

4. Overall Pre-Launch Sequence. The ability to determine when and how to vary the sequence steps will relate to the observer's experience level. Pre-launch is a key part to having consistent successful launches to form a pattern of performing these pre-observation operations with the ability to adjust for possible changes due to instrument problems, weather conditions and even ground equipment limitations. See Table E-1 that illustrates these steps and approximate times the steps should be performed for sites using RDF tracking equipment.

- a. Observer actions prior to GPS radiosonde launch. The pre-launch sequence has three main components:
 - (1) Equipment warm-up.
 - a. The UPS should be powered up prior to filling the balloon.
 - b. Powering up the UPS allows for proper warm-up times for SPS and motor warm-up operations.
 - (2) Inspect the radiosonde for any physical defects (broken, missing components). Reject it and use another if necessary.
 - (3) Balloon inflation and train assembly
 - (4) Weather station operations:
 - a. Hardware status check.
 - b. Entry of pre-observation information.
 - c. Instrument baseline.
 - d. Antenna positioning.
 - (5) Release Site Processes:
 - a. Final train preparations.
 - b. Launch approval.
 - c. Possible repositioning of antenna.

- d. Decision on method of launch (with or without CDU).
 - e. After release with the CDU, verify signal strength, frequency and tracking .
- b. Observer actions prior to RDF radiosonde launch - The pre-launch sequence has three main components:
- (1) Balloon inflation and train assembly.
 - (2) Weather station operations:
 - a. Equipment warm-up and hardware status check.
 - b. Entry of pre-observation information.
 - c. Instrument baseline.
 - d. Final antenna positioning.
 - (3) Release site processes:
 - a. Final train preparations.
 - b. Launch approval.
 - c. Possible repositioning of antenna.
 - d. Decision on method of launch (timed or manual).

Table E-1- Sequence Actions Prior to Launch for RDF. Launch time is marked as T-00 minutes.

TIME TO LAUNCH	OBSERVER ACTIONS FOR RDF RADIOSONDE
T- 45 minutes	Turn power on at MCU. Begin filling the upper-air balloon and prepare the balloon train. (Ground equipment needs at least 15 minutes to warm-up)
T-20 minutes	Thoroughly inspect radiosonde and components. If required, insert humidity sensor into the radiosonde. If using a Lockheed Martin Sippican radiosonde, place on the power supply for at least 5 minutes.
T-19 minutes	Start MicroART. Do a System Status Check. Open and update the

	administrative data file.
T-16 minutes	Update Equipment Data and Radiosonde Serial Number in the MicroART Prerelease Data.
T-15 minutes	Place radiosonde battery cell in water to begin its activation.
T-12 minutes	After battery has reached acceptable voltage, install battery in radiosonde. Place radiosonde on Styrofoam block or suspend to avoid erroneous frequency readings. (Position antenna to point at radiosonde)
T-11 minutes	Monitor RDF console's readouts to check for the proper radiosonde transmitter frequency and signal strength values.
T-10 minutes	Take and enter the surface observation to MicroART's Surface Data Screen.
T-09 minutes	Start the baseline procedure on the MicroART workstation. Compare the instruments pressure reading with the station pressure.
T-08 minutes	Place log disk in the MicroART A: drive.
T-07 minutes	Adjust antenna elevation and azimuth for release then, depart for the release site. (Motors are put in Standby)
T-04 minutes	Open remote release panel, turn on power, and turn up speaker volume. Check for clean signal.
T-03 minutes	Tie the radiosonde to the assembled balloon train.
T-02 minutes	Check the balloon-train's integrity and visually survey the release zone and the anticipated path of radiosonde. Minimize potential for obstacles.
T-01 minutes	Phone the local airport control tower and coordinate release if required. Monitor RDF remote panel for signal quality and ensure RDF antenna is positioned to best track the radiosonde through its expected path.
T-00 minutes	Observer should routinely do a timed release to eliminate missing data for the first few seconds of the observation. Not starting the equipment at release will cause height errors as well.

Table E-2 - Sequence Actions Prior to Launch for GPS. Launch time is marked as T-00 minutes.

TIME TO LAUNCH	OBSERVER ACTIONS FOR GPS RADIOSONDE
T- 45 minutes	Start RRS workstation. (Allow the TRS 30 minutes warm-up prior to baseline). The TRS Status Line on the Antenna Orientation/TRS Display will indicate "TRS IS READY".

T-44 minutes	Begin filling the upper-air balloon and prepare the train.
T-20 minutes	Inspect radiosonde sensors, case, and battery for damage.
T-17 minutes	Set frequency on the instrument and then set the frequency in the Antenna Orientation TRS display window. Manually move the TRS Antenna to the baseline point.
T-16 minutes	Lockheed Martin Sippican MKIIA – Place radiosonde battery in water (Label side up) to activate (2 minutes) and ensure GPS repeater is powered on. Complete the harmless instrumentation sticker and place on radiosonde.
T-14 minutes	Install battery in radiosonde. Connect the black (Ground) wires first, then the red power wire and place on baseline stand under the powered-on GPS repeater. Update Administrative and Equipment Displays. (Verify the signal strength values are acceptable and the AFC is on). Wait at least 5 minutes to warm up the battery before proceeding to next step.
T-09 minutes	Complete the Surface Observation Display and start the baseline procedure on the RRS workstation. Wait at least 5 minutes before proceeding to next step. Compare the instruments pressure reading with the station pressure. If within + 5hPa and the temperature and relative humidity values look reasonable click accept. NOTE: Ensure pressure sensor has stabilized prior to accepting baseline. The battery and pressure sensor have to warm-up. If the pressure sensor is not warmed-up, pressure discrepancy may create height errors.
T-04 minutes	Adjust antenna elevation and azimuth for release, and then depart for the release site. (Antenna is placed in the manual track mode)
T-03 minutes	Check the radiosonde signal to ensure frequency has not shifted off the radiosonde and the signal is strong. Double check to ensure the Antenna is positioned to the appropriate azimuth and elevation. Turn up the volume of the CDU. You should hear noise - That noise is the radiosonde.
T-02 minutes	Tie the radiosonde to the assembled train.
T-02 minutes	Check the balloon-train's integrity and visually survey the release zone and the anticipated path of the balloon. Minimize potential for obstacles.
T-02 minutes	If applicable, phone the local airport control tower and coordinate release if required.
T-01 minutes	Verify that the TRS Antenna is positioned correctly for launch.

T-00 minutes	<p>The observer should release the radiosonde and use the CDU to lock-on to radiosonde for all launches other than method b shown in Section 13.2.2.</p> <p>Note: Before leaving the Release Site validate the receiver is still locked on the radiosondes frequency and the signal is acceptable.</p>
--------------	--

Table E-3 – Observation Check List for RRS.

IN ORDER	OBSERVATION CHECKLIST FOR RRS
STEP 1	Ensure the release has been detected (Release time is displayed in the flashing blue screen and in the Status Messages), and click “Continue” Update Surface Observation after release as necessary.
STEP 2	Verify that the TRS signal strength is acceptable. Open up the Processed Tabular Display and scroll to the bottom of the display. (right-click on the scroll bar and select Bottom). Go to the Azimuth and Elevation columns and input these values into the desired Azimuth and Elevation cells on the Antenna Orientation Display. Click Move Antenna and then select Search in the track mode. Ensure there are good signal(s) in SPS/GPS window.
STEP 3	Verify that the Release has been detected correctly. Ensure the first pressure data point below the red line in the Received PTU Tabular Display has a pressure equal to or less than the Release Pressure shown in the Surface Observation at Release. Check the Geopotential Height and ensure it increases with time. Otherwise change the release time as appropriate.
STEP 4	Check RH Data immediately off the surface for dry bias. Mark data if necessary to make profile representative of existing weather conditions.
STEP 5	Monitor observation using Displays and Plots – Consider creating Workspace. Basic Screens: SPS/GPS Window...Antenna/TRS Display...Temp of Temp/RH Plot...Trajectory Plot...Processed Tabular Data Display or Processed Data Bar.
STEP 6	At message generation- Always look at Check and Status messages, Temp or Temp/RH plot and verify the Ascent Rates are realistic (averages approximately 5 m/sec) Look at the last few minutes of Processed Tabular Display GPH changes.
STEP 7	Verify RADAT or coded messages appear to be correct.
STEP 8	Call-up the Thanks message and verify message receipt.
STEP 9	Review selected plots and data at least every 15 minutes during the observation and always perform STEP 6 prior to transmission.
STEP 10	Add comments to Status message- If unusual meteorological situations are encountered or problem/issue with equipment or instrument is found. Print screens or plots as necessary to document problems.
STEP 11	At termination- Turn UPS off. Note: TRS antenna will not reset to startup position of 360 degrees and 0 degrees elevation if the UPS is not turned off.
STEP 12	Validate correct termination pressure and height has been selected. Look at the

	last Processed Data Point (shown in green line) and ensure that it shows the lowest pressure and that it has an ending ascent rate during the last minute or so of approximately 5 m/sec.
STEP 13	Prior to message transmission at termination, ensure all Check and Status messages look reasonable. Do the same for the data plots.
STEP 14	Verify all messages received in the Thanks message.
STEP 15	Print the summary, WMO Coded messages, Check and Status messages, and plots considered pertinent.
STEP 16	Close the observation. Do not exit RRS until going to Offline mode>Tools>Utilities and archiving the observation.
STEP 17	Exit RRS.

Table E-4- Post Observation Check List for RRS.

IN ORDER	POST – OBSERVATION CHECKLIST FOR RRS
Step 1	Create Archive files.
Step 2	Compress/Rename Archive files. FTP compressed files to NCDC.
Step 3	Capture the observation- 1 st 30 days (Every observation). After the 1 st 30 days (Observations with problems).
Step 4	Open MIRS and complete the Weather Service (WS) Form B-29 and WS Form B-85.
Step 5	Enter Engineering Management Reporting System (EMRS) if equipment problem encountered.

5. Equipment Warm-up.

5.1 RDF Tracking Equipment Warm-up. The RDF tracking equipment is warmed up a minimum of 15 minutes prior to doing a status check and checking the antenna orientation. Turn the power switch on at the MCU and make sure the motors are in standby.

5.2 RRS Tracking Equipment Warm-up. RRS tracking equipment warm-up will vary mainly due to change in temperature within the radome. You will see a status message, “TRS initialization in progress” in the Antenna Orientation/TRS display. When TRS warm-up is complete, the “TRS is ready” will replace “TRS initialization in progress” in the Antenna Orientation/TRS display. A minimum of 30 minutes warm-up time is required prior to launch.

Note: The SPS requires a minimum of 12 minutes warm-up prior to initiating the “Baseline Check”.

6. Preparing for Antenna Orientation.

6.1 RDF Antenna Orientation. After the tracking equipment has warmed up, take the motors out of standby on the MCU and position the antenna manually within a few degrees of the documented azimuth and elevation points for the target antenna. Turn the target antenna switch on and allow the antenna to lock on the target antenna by pressing the FAR AUTO button, (Low

sensitivity OFF).

6.2 RRS Antenna Orientation. Antenna orientation with the RRS tracking equipment is not critical as with RDF tracking equipment. Using the “RRS Antenna Display” window on the RRS workstation, the antenna should be positioned within a few degrees of the baseline point prior to beginning the baseline check.

7. Obtaining Status Check and Orientation.

7.1 RDF Equipment Checks. Turn on the MicroART computer. Select ART Options and select Check System Status. The check of the ART Interface Card (ARTIC) and SPU-11 board (For Vaisala radiosondes) if installed will be tested as will the printer and modem. When the Status Check is completed the orientation check section appears. When the angle readings stabilize and both of the new corrections are less than 0.05 degrees press [Enter] to save them. If unable to get the readings within 0.05 degrees repeat the orientation check following the procedures in Chapter 7 of the MicroART Training Guide.

7.2 RRS Hardware Status Checks. Turn on the RRS workstation and log in with your Username and Password. After the Security window appears and the Live Flight Option is selected the Hardware Status window appears. After the UPS has been powered on and the TRS has completed its initialization the various components except for the SPS and GPS should have a green check mark when operating properly. The SPS and GPS status can not be determined until a radiosonde has been prepared and connected to the battery during the baseline process. Chapter 7 of the RRS User Guide titled “Checking the Hardware Status” provides detailed information on the various hardware components checked and recommended actions.

8. Enter Pre-Release Data into MicroART. Follow instructions on entering administrative data, equipment data, radiosonde data, and surface data shown in Chapter 8 of the appropriate Training Guide.

8.1 Administrative, Equipment, and Radiosonde Data. This information is easy to follow for both systems, it is menu driven and requires little explanation.

8.2 Surface Observation at Release Site. Take a complete surface observation within ten minutes of the time of release and enter the data into Surface Observation Display. Whenever the surface observation is not taken within 10 minutes before release time, it should be retaken as soon as possible after the release.

Under no circumstances will estimated values for station pressure, temperature and dew point be used for the surface weather observation. In case of observation equipment failure see Section 8.3 for information.

Note: Data from the Radiosonde Surface Observing Instrument System (RSOIS) and Precision Digital Barometer (PDB) at RRS sites are ported into the RWS and appears with the surface observation display.

8.2.1 Pressure. Station pressure is obtained from a NWS approved PDB corrected to read the height at where the instrument is baselined in the office. Readings will be entered to the nearest tenth of a hectopascal. When the surface pressure is less than 1000 hPa, the temperature entry from twelve hours ago will be entered to allow the software to estimate the 1000 hPa height or other heights for standard pressure levels less than that being observed. In addition, the digital barometer's surface pressure will automatically be registered into the flight log and, under usual circumstances; an adjustment will be made to the radiosondes pressure reading to make it the same as the digital barometer's reading. Instructions on editing surface data are explained in the appropriate user Training Guide.

The MicroART software has a significant difference between the Vaisala software and VIZ software. VIZ sites may reenter the Surface Data screen anytime during the observation, but Vaisala sites are only allowed to reenter the Surface Data screen for just the first few minutes after release. The Vaisala SPU-11 card uses the value to generate future data points and once locked-in it can not be changed. Therefore, it is important that the surface data be verified as soon as possible after release. The RRS software allows the operator to change the Surface Observation anytime during or after the observation but the pressure data change does not result in a recalculation of pressure values aloft.

The PDB's are re-certified for accuracy annually per the NWS standard for barometers. Each year, the standards laboratory automatically replaces the PDB's with programmed value (elevations and R values) put into the instrument for all sites. The PDB's have special boxes to protect the instrument.

8.2.2 Temperature. Record the dry bulb temperature to the nearest tenth of a degree Celsius.

8.2.3 Dew Point. Record the dew point temperature to the nearest tenth of a degree Celsius. When entering the surface observation, check to confirm the dew point temperature is valid and does not exceed the surface temperature.

8.2.4 Wind Direction and Speed. Enter the wind direction to the nearest 5 degrees in MicroART. The RRS software allows winds to be entered to the nearest whole degree. For calm winds, estimate a direction or use 360 degrees. The wind speed is measured or estimated to the nearest knot. For calm winds, a single zero (0) can be entered for wind speed.

8.2.5 Clouds and Weather. Enter the nine digit code that contains the weather at the observation time. The clouds/weather part of the observation uses a modified WMO format in order to meet NCDC requirements for clouds and present weather. The RRS uses the cloud/weather group to apply a temperature correction for solar radiation. This has to be as accurate as possible. Appendix B of the MicroART Training Guide explains the following code for the upper air observation.

N_hC_LhC_MC_HWWWW

N_h - Amount of sky covered in oktas (eighths) by low clouds, or if no low clouds are present, coverage by middle clouds

C_L - Type of low cloud

h - Height of the lowest cloud base

C_M - Type of middle cloud

C_H - Type of high cloud

WWWW - Present weather coded in two groups of WW. Enter the two code groups from Appendix B of the MicroART Training Guide (with highest numerical priority) that best represent the site's weather. (Note that some code groups refer to weather during the previous hour but not at the time of observation.) The code with the highest priority should appear first. If only one WW group is applicable to the present weather, then use that code twice.

EXAMPLE: The following clouds/weather condition would be encoded 657082001.

- 6 - 6 oktas sky coverage by low clouds.
- 5 - Stratocumulus clouds (not formed by the spreading out of cumulus).
- 7 - Cloud bases between 5000 and 6500 feet.
- 0 - No middle clouds.
- 8 - Cirrostratus clouds (not covering the whole sky and not invading the celestial dome).
- 20 - Drizzle during the preceding hour, but not at the time of observation.
- 01 - Clouds generally dissolving or becoming less developed during the past hour.

To validate the cloud/weather code, ensure that: (a) nine digits were entered, and (b) the field was not all of one character (e.g., //) or does not contain letters or other characters (e.g., A, X, \$).

8.3 Surface Observation Equipment Failure.

If the PDB, RSOIS or ASOS equipment used for taking the surface weather observation has failed, the following equipment may be used as a temporary backup:

Station Pressure: If available use another PDB in the office set to the same height as failed primary PDB. If one is not available, a sounding can not be taken and the flight will be logged as missed.

Temperature and dewpoint: Use a WSH approved psychrometer with the measurements taken over natural terrain (no concrete or asphalt surfaces) and within 200 meters of the balloon release point.

Winds: Wind speed and direction entries can be estimated. Use nearby surface weather observations as a guide.

Cloud Height: This measurement can be estimated. Use nearby surface weather observations as a guide.

9. Baselining the Radiosonde.

9.1 Check the Radiosonde Sensor Accuracy. The observer checks the real-time surface pressure (P), temperature (T), and relative humidity (U) values as measured by the radiosonde sensors displayed during the baseline process. Care is taken to obtain the best possible signal and eliminate possible antenna loading. The RDF antenna motors should be in standby, and the instrument should be placed on a styrofoam block or hung by a string.

The RRS GPS tracking antenna should be placed in the “Manual” tracking mode, it should also be pointed at the radiosonde and set to the proper frequency with AFC turned on. This will eliminate antenna movement and noise during baseline.

Present baseline procedures only allow for a comparison of pressure values. If the pressure value is ± 5 hPa off from the approved station pressure measuring device, the baseline should be run again, if the error still exists, reject the instrument. It is important to remember that only the pressure sensor is actually being compared with the instrument inside the office. The temperature and RH readings the radiosonde is compared to are located outside the office. The temperature or relative humidity sensor may be considered out of tolerance if the readings themselves are considered by the observer to be unrealistic (i.e., 105% RH or 50⁰ C.) The observer may place the radiosonde outside near the surface observation equipment to verify the accuracy of the instrument's temperature and RH measurements.

Erroneous radiosonde RH data may be the result of air trapped within the sensor duct or water vapor from the wet battery. The radiosonde should be held at arms length and swung back and forth to force ambient air across the sensor surfaces. If inaccurate values persist, reject the instrument.

Continue to monitor the Surface Data Screen values and if P, T, U values are out of tolerance (e.g., $> \pm 5.0$ hPa) then select and prepare another radiosonde to replace the discrepant one.

9.2 Baselining the RDF Radiosonde. Ensure the battery is activated and properly positioned within the radiosonde. Next, set the radiosonde upon an insulated block or similar object (do not

set on a table or cabinet). Align the antenna so that it is pointing at the radiosonde. Allow the antenna to lock-on the strongest signal before placing the motors in standby. Verify the transmitter's signal strength and the receiver's ability to lock onto the proper frequency with the RDF console meter. Note the meter readings. Ensure the carrier frequency is within ± 5 MHz of 1680 MHz. Signal strength should be at least 60 dB. The signal check should be completed approximately 10-15 minutes before release.

Check the automatic frequency control (AFC) meter to ensure the transmitter signal is being received clearly. If the AFC indicates signal fade or drift, reposition the radiosonde and check again. If the signal is still unacceptable, check the battery strength and replace the battery if necessary. If AFC still fails to achieve lock-on, replace the radiosonde. Follow the baselining procedures described in Chapter 8 of the MicroART Training Guide.

9.3 Baselining the GPS Radiosonde. Set the frequency on the radiosonde and align the antenna so it is pointing at the radiosonde. Prior to starting the baseline, ensure the radiosonde has been on battery power and under the powered on GPS Repeater for a minimum of 5 minutes. Click the "AFC" button. Next ensure that the battery is activated and properly positioned within the radiosonde. Click "Set" button in "Antenna Orientation/TRS Display" window and enter the desired frequency. The signal strength should increase when the frequency is located. The signal may differ from the frequency that was set by .1 or .2 MHz, but this is within tolerance.

Place the antenna in the "Manual" tracking mode. When the maximum signal is received, click the "Next" button to move from the "Surface Observation Display" window to the "Radiosonde Baseline" display. Wait at least 5 minutes after baseline begins so the internal components can stabilize and the pressure sensor has time to ensure an accurate discrepancy is used for the observation and data are received that look consistent with the "Station" surface data before accepting. If you do not acquire GPS lock, first reset the radiosonde, (unplug for 30 seconds, red wire first and then reconnect with the black wire first). If that does not work, reset the SPS in the "Hardware" status window. Finally, as a last resort, reset the UPS in the "Hardware" status window.

If doing a second or third release be sure to set the frequency on the radiosonde and in the Antenna/Orientation display well prior to baseline. Do not use the "Scan" button.

10. Transportation of Instrument to Release Site. When a successful baseline is obtained, the antenna should be positioned to point in the approximate direction the balloon is expected to travel with the elevation adjusted for wind conditions. When this is completed the motors should be placed in Standby for the sites using the RDF equipment and for those using RRS the track mode should be placed in manual. This will eliminate the antenna from attempting to track the instrument during transport to the inflation building. Not doing so, may cause damage to the antenna tracking system and may also cause the antenna to lose the signal and go into the "Suspend" mode. If the TRS goes into "Suspend" the CDU will indicate "Suspend" on the display. The system will correct this issue without assistance.

Note: Sites using GPS radiosondes should be aware that GPS lock will take as much as 20 seconds to be re-established if the instrument is taken inside the inflation shelter and tied to the balloon train. Under most weather conditions, the instrument should be placed on an elevated platform or basket and left outside with the train attached to it. If this is not possible, the radiosonde should be taken outside and not released for at least 20 seconds to ensure the GPS signal is re-acquired.

11. Final Inspection of Balloon Train. After the balloon has been inflated and the train has been assembled, inspect the tie points along the train to ensure cord connections are fastened tight. Ensure that the balloon neck is not being overly strained. Ensure the train cord to the radiosonde is untangled and will flow freely through the hand or through the train regulator. Do not forget to check the cord at the bottom of the radiosonde to ensure it has been tightened properly.

Release procedures vary with the wind conditions at the release site. The observer should be familiar with all obstructions around the area before attempting a release. Before the balloon is removed from the inflation shelter, the observer rechecks the wind direction and speed.

Visually check to confirm that the temperature and humidity sensors are properly positioned and not damaged. Ensure the battery is firmly encased within the body of the radiosonde.

Observers are reminded that high winds and heavy precipitation increase the risk of balloon train entanglement in trees, high-tension power lines, and various antenna masts. To the extent possible, measures should be taken to reduce the possibility of entanglement (i.e., add extra free lift during inflation). If entanglement with a power line or antenna mast occurs, no attempt should be made to disentangle the rawinsonde. The circumstances will be reported at once to the appropriate owners of the power lines or tower.

During the release, be mindful that water from the battery may drip out. Observers should position themselves so as to avoid water dripping on them.

12. Final Safety Check. No matter where a NWS site may be located care is exercised prior to launching a rawinsonde observation.

The following procedures will be complied with by all NWS sites:

12.1 Notify the Local FAA Tower. An upper-air site located within 5 nautical miles of a controlled airfield will call the local Federal Aviation Administration (FAA) Tower immediately before a rawinsonde observation to coordinate the balloon release. A visual search of the observation area should be made. Observations taken at or near major air terminals, pose a greater risk to aircraft than do those which are taken in remote areas. This is especially true during the initial low level phases of the observation where there is generally a greater concentration of aircraft converging during takeoff and landing operations.

Controlled airports are illustrated in aeronautical charts with blue airport symbols. The FAA airport facilities directory, which is reissued every 56 days, gives the hours of operation for the controlled airports. During hours the airport is unmanned, the procedures listed in section 12.2 for non-controlled airports will be followed.

12.2 More than 5 Nautical Miles from a Controlled Airport or at a Non-Controlled Airport.

Upper-air sites at or near airports which are not controlled or at which the controlling authority is not in operation will visually check the whole sky to ensure there are no aircraft in the area that might be affected by releasing the radiosonde. A visual check of the whole sky will be made at all upper-air sites prior to launch of the balloon train.

Each office should work to limit risk from the potential hazards that surround the release site. Special procedures should be documented in the Station Duty Manual (SDM).

13. Radiosonde Launch Procedures. The observer will follow safety procedures for site-specific inflation equipment and will work to limit risk from the potential hazards that surround the release site. Special procedures will be documented in the SDM.

13.1 RDF Radiosondes. Ensure that the MCU and RCU consoles show the receiver system is in STANDBY. Then perform the following operations:

AT REMOTE CONTROL UNIT: (See Figure E-1)

- a. Press the following push-button switches as indicated and observe the listed indication.

<u>SWITCH</u>	<u>INDICATION</u>
NEAR AUTO (Ant Track)	NEAR AUTO (button lights on)
MANUAL	(button goes dark)
LIMITED (Freq Search)	LIMITED (button lights on)
MANUAL	(button goes dark)
STANDBY (Toggle off)	STANDBY (button goes dark)

- b. Operate ELEVATION and AZIMUTH switches to point antenna in the direction you expect the radiosonde to travel at release. Azimuth dial reading will be 180 degrees from the direction of travel.

NOTE: Do not place the radiosonde on the ground at anytime! This can cause antenna loading which will cause a frequency shift once the instrument becomes airborne. The frequency drop may be from 5 to 10 MHz. This drop in frequency may cause the receiver to go into a limited search and if the change is beyond 5 MHz a full search may be initiated that could cause the search sequence to last as long as 40 seconds.

- c. Set SIGNAL/FREQ Switch to SIGNAL LEVEL. Check for adequate signal strength.
- d. Observe AFC Indicator. This button should be lit.
- e. Set volume level of MET data signal.
- f. Press REMOTE RELEASE Switch. Release tones should be heard from the loudspeaker.
- g. Walk to balloon release site and release the balloon. If foul weather is occurring at release time, follow instructions in section 13.3.

Note: Immediately after release, an operator should stand-by to adjust antenna position if necessary, to aid the system in gaining lock-on to the radiosondes main lobe. The manual adjustment is simplified by placing the tracking mode in “Manual” rather than near or far auto. Then by adjusting the ELEVATION and AZIMUTH toggle switches and possibly using the wind rose and a clinometer as aids.

- h. If the LOW SENSITIVITY indicator button is illuminated, press the button to return to high sensitivity. Indicator button should be dark (not illuminated).
- i. When the radiosonde is a sufficient distance from the antenna for smooth tracking and is not expected to go directly overhead; press FAR AUTO (Antenna Tracking) switch. The FAR AUTO switch should illuminate and NEAR AUTO (Antenna Tracking) should go dark.

13.1.1 Fair Weather Launches. Follow the procedures described in Section 13.1, Items a-i.

13.1.2 Calm Wind Launches. Follow the procedures described in Section 13.1, Items a-i. On occasion, the RDF antenna will lock-up when the rawinsonde becomes positioned above the

RDF tracking unit. This may occur when winds are calm at the surface, or if winds bring the radiosonde over the station and into a layer of light and variable winds aloft.

When the tracking antenna is stuck in a high elevation angle position, override the AUTO tracking system and manually control the antenna to a slightly lower angle. Then search and reacquire the radiosondes signal through full and limited-scale frequency scanning and manual antenna repositioning with visual tracking if necessary.

In many cases, the software will detect a locked antenna. MicroART software will automatically delete the position data during the period of the lockup. However, if this period is short, the software may not detect the lockup. See MicroART Training Guide, Chapter 9.5.3 for procedures needed to edit data (e.g., angles and winds).

13.2 GPS Radiosonde Launches. Position the antenna in the direction that winds are expected to take the instrument. There are two techniques that may be used to acquire the signal.

13.2.1 Launches using the RRS Workstation. The primary launch method for locking onto the radiosonde is using the RRS Workstation. This method minimizes the time the observer is outside of the office.

- a. Before launch, in the RRS Antenna Orientation/TRS Display:
 - (1) Pre-position the antenna in the general direction the winds will take the balloons.
 - (2) Place the antenna into **Manual** track mode.

Note: Always check the upper level winds before going to the inflation building. If GPS is lost, a reasonable approximation can be made to locate the radiosonde upon returning to the office. This first step should be used for all releases.

- b. After launch return to the office.
 - (1) If GPS data is being received.
 - a. Click the **Search** mode button in the Antenna Orientation/TRS Display. The antenna will automatically attempt to find the radiosonde using the last GPS calculated location (azimuth and elevation). This can be found in the Azimuth and Elevation columns of the Process Tabular Display.

- b. Once the antenna has found the radiosonde it will transition into Auto track mode, and force the AFC on.
- (2) If GPS data is missing.
- a. In the Antenna Orientation/TRS Display, point the TRS to a reasonable approximation of the radiosonde position using upper level winds. If available, use the most recent Azimuth and Elevation data from the Processed Tabular Display.
 - b. Click the Search button to place the antenna into Search mode.
 - c. Once the antenna has found the radiosonde it will transition into Auto track mode, and force the AFC on.

Note: If the antenna does not find the radiosonde, the antenna will transition to Full Search mode. If this occurs, place the Antenna back into Manual track mode and reposition the antenna and reattempt the search.

13.2.2 Launches Using the RCDU. An alternate launch method is to lock-on to the radiosonde using the RCDU at the release point.

- a. Before launch, in the RWS Antenna Orientation/TRS Display.
 - (1) Pre-position the antenna in the general direction the winds will take the balloon.
 - (2) Place the antenna into **Manual** track mode.

Note: Always check the upper level winds before going to inflation building. If GPS is lost, a reasonable approximation can be made to locate the radiosonde upon returning to the office. This first step should be used for all releases.

- b. Before launch, using RCDU at the release point.
 - (1) Ensure the antenna is in Manual tracking mode by pressing the **5** key.
 - (2) Slew the antenna slightly to validate the antenna will move.
- c. After release, using the RCDU at the release point.

- (1) Slew the antenna toward the radiosonde, before selecting the 4 key to Auto track the radiosonde. Use the Tracking Errors (Err) and signal strength (SIG) as a guide.

Note: The Tracking Error (**Err**) value arrows (< , > , ^ and v) indicate the direction to slew the antenna toward the radiosonde. The **Err** values do not equate to degrees, but indicate the proximity to the radiosonde; the smaller the value, the closer the antenna is to the radiosonde. When slewing the antenna, if the arrows reverse direction for both azimuth and elevation, the antenna is pointing at the radiosonde.

- (2) If the antenna does not lock on the radiosonde.
 - a. Place the antenna in the Manual track mode by pressing the 5 key.
 - b. Point the antenna toward a reasonable approximation of the radiosonde position.
 - c. Select the 4 key to Auto track the radiosonde.

13.3 Foul Weather Launches. Sometimes the weather at release is poor and special procedures need to be followed to ensure a successful observation.

13.3.1 Heavy Precipitation. Heavy precipitation (rain, freezing rain, or ice pellets) is defined by Weather Service Observing Handbook (WSOH)-7 as 0.30 inches per hour or more than 0.03 inch in 6 minutes. Snow or drizzle can be estimated by visibility that is less than or equal to one quarter of a mile. This rate will place loading on the balloon and result in slower ascent rates during the observation.

General guidelines for heavy precipitation events:

- a. Use extra gas (free lift).
- b. Take the observation later if the precipitation is expected to move through the area or diminish in intensity.

13.3.2 Freezing Precipitation. Freezing precipitation can significantly slow the radiosonde flight. Freezing precipitation can accumulate on the balloon and radiosonde. The observer should use 300 grams extra gas when moderate icing is expected and 500 grams or more extra gas if severe icing is likely.

13.3.3 High Winds. The observer will be aware of the obstructions around the upper air shelter

before attempting a release. Before the balloon is removed from the inflation building, the wind direction and speed should be determined. Note the period of gusts and type of turbulence that could pose a risk to the rawinsonde flight release.

13.3.4 Two-Person Technique. If a train regulator or dereeler is unavailable or time does not permit the reconfiguration of a train and an assistant can lend a hand, the two person technique is recommended for high wind cases. This technique can be conducted from the NWS standard inflation shelters; however it does not apply to the confines of a balloon inflation launch shelter (BILS). The two observers should plan the radiosonde release in advance for the technique to be successful.

The first observer will hold the tie-ring or cord above the radiosonde in one hand, grasp the cord further up the train with the other hand and extend the train downwind until a slight tension is exerted to avoid having the train become tangled. The second observer will then remove the balloon from the shelter; the balloon will be taken as rapidly as is practicable to the pre-selected site, with the first observer ensuring that the cord does not become tangled.

Correct positioning is the responsibility of the observer with the radiosonde since under these conditions the observer with the balloon will find it more difficult to change position. When the release area is reached, the observer holding the balloon will release the balloon and the instant the train slackens, the first observer will run downwind until the balloon takes up the slack. As this happens, the first observer will raise the radiosonde with one hand and bring the cord forward in the other hand. If the movement of the hands is coordinated, the radiosonde will lift away with no noticeable jolt.

When obstructions prevent the observer with the radiosonde from running downwind, the observer holding the radiosonde will stand in a position to observe the movement of the balloon. At the instant the balloon takes up the slack, the observer will follow through with the radiosonde to reduce the jolt and possible damage to the radiosonde.

13.3.5 Thunderstorms. ***The radiosonde will not be launched into thunderstorms.*** If a thunderstorm is occurring at the time of balloon release, the observer will wait until the storm passes before releasing the balloon. Three important reasons not to release during a thunderstorm are:

- a. The observer increases the likelihood of being killed by a lightning strike as he/she proceeds to release the balloon. During a storm, the balloon train can become a lightning rod with the observer holding the lower end.
- b. The data collected inside or near thunderstorms are erroneous and not useful for weather forecasts. The observation does not represent the synoptic scale environment and NCEP does not use such observations for ingestion into numerical weather prediction models.

- c. Thunderstorms typically terminate an observation early owing to balloon icing or strong downdrafts.

A thunderstorm is defined as ending when at least 15 minutes have passed since the last clap of thunder was heard. If the storm persists during the entire release time window (see section 2), then the observation will be logged as missed.

13.4 Delayed Release. The radiosonde should be released within the officially prescribed time limits. If a release is delayed beyond 45 minutes, consideration should be given to replacing the battery. If replacement is necessary, procedures shown in Chapter 8 of the MicroART and RRS Training Guide should be followed. These procedures will vary depending on when during the pre-release sequence; the determination was made to replace the battery.

13.5 Operation of RDF Remote Release Timer Switch. The remote release switch is a timed device that emits tones for 1-minute prior to release. Ten seconds before the release, the switch activates a prolonged tone. Intermittent signals are heard until another prolonged tone indicates the automatic release has been initiated. The observer should have released the balloon train with the last tone.

Follow the procedures described in Section 13.1, Items a-i. The purpose of doing a timed release is to allow one observer to launch a RDF radiosonde under routine conditions. Releasing the balloon and having the tracking equipment begin tracking at the proper time is essential in determining accurate heights. Observers not using the remote release timer may take several seconds to manually push the start switch. This time between balloon release and the time it takes to push the switch is lost data. The data recognized after the start switch is pressed may actually be several hundred feet above surface, but the tracking record will consider it as the first data received just above the surface.

14. Maintaining Proper Signal Lock-On. The tracking antenna receives radiosonde radio signals in two distinct patterns, one associated with the main lobe and the other, the side lobes. If the Radiotheodolite system locks onto a side lobe instead of the main lobe, the position data are incorrect and tend to be very erratic with time. Wind data determined to be derived from side lobe tracing are in error and will be deleted. The RRS antenna may also lock-on a side lobe as well, but winds are derived from the GPS data transmitted from the radiosonde. Wind calculation has nothing to do with the position of the RRS antenna. The only requirement is to have the TRS antenna receiving a strong signal.

At times owing to signal interference (i.e., noise), weak or fading signals, or faulty ground equipment, erratic angular data may result. This situation for the RDF tracking equipment is most prevalent when elevation angles are below 12 degrees, but can occur at other angles. This situation can cause a spike to appear in the data. Sudden, abrupt changes in the 6-second elevation or azimuth angles of the antenna are not realistic and are caused by signals too weak to

supply the ground receiver with an adequate reference or by the lack of tracking sensitivity in the ground equipment.

Another type of erratic elevation angle with RDF tracking occurs, when angles are greater than 12 degrees and at least 15 minutes of the observation have elapsed. In this case, erratic angles may be caused by equipment not operating properly, tracking a secondary lobe, or due to a signal loss. The result will be tracking errors in excess of predetermined tolerances in azimuth or elevation angles.

Erratic RDF angles or spikes in the data are deleted as such data results in erroneous winds. Follow the data editing procedures described in chapters 9 and 14 of the MicroART Training Guide.

MULTI-PATH PROPAGATION AND LIMITING ANGLES: Multi-path propagation causes the RDF antenna to stay in one position for a short time and recover when it gets an adequate signal. This will cause the antenna to bounce creating plots of the elevation angles with steps, or waves. This situation is most prevalent when elevation angles below 12 degrees are encountered and becomes increasingly pronounced as the elevation angles near 6 degrees. If multi-path propagation is determined to be occurring, the anomalous data will be deleted as described in chapter 14 of the MicroART Training Guide.

The limiting angle is the elevation and azimuth angle of the RDF antenna at which the antenna cannot successfully track the radiosonde owing to multi-path propagation. Limiting angles are no less than 6 degrees off the horizon or obstructions (e.g., mountains or buildings) along the horizon. The MicroART software contains a station data file with the limiting angles for the site. Site personnel are responsible for ensuring the information is accurate. Whenever the elevation and azimuth angles are equal to or less than the limiting angles, the angular data is not used to calculate winds. Appendix J Section 4.2 provides information on how limiting angles are determined at each upper-air station.

The RDF tracking system is fully locked-on to the radiosonde transmitter's principal signal (e.g., not a side-lobe). This ideal state of signal reception is indicated by a lit AFC lamp on the MCU (position #22 Figure B-8) and the RCU (position #21, in Figure E-1).

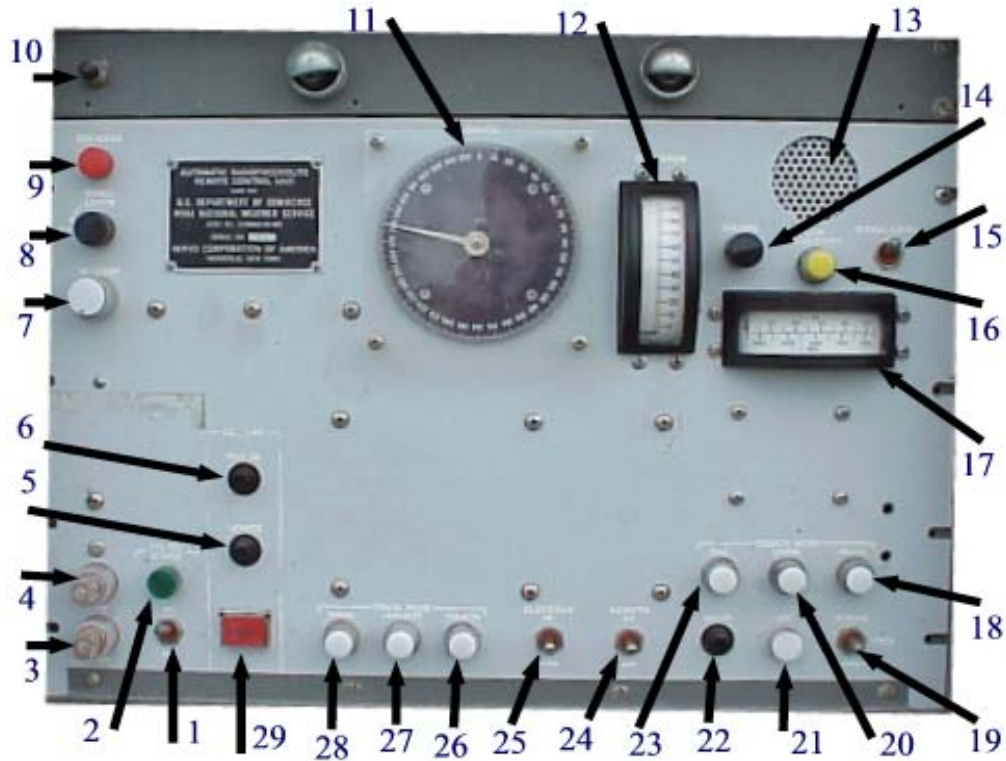

Figure E-1 - Open Remote Control Panel

15. Antenna Tracking Modes.

15.1 RDF Antenna Tracking Modes. This section discusses the three tracking modes which may be used to steer the antenna to acquire the radiosondes transmitted signal.

NEAR AUTO: The RDF system automatically and rapidly tracks the flight of the radiosonde.

FAR AUTO: The RDF system automatically and slowly tracks the flight of the radiosonde.

MANUAL: The RDF system permits the operator to override the automatic antenna tracking modes. This mode is typically used to lock on the radiosonde at release. It is especially helpful during strong low-level wind shear or when the radiosonde has tracked overhead. Separate controls allow the observer to manually steer the RDF tracking antenna and control the antenna's rate of slew to the desired elevation and azimuth angles. To reacquire signal lock-on, the observer should be familiar with five control points on the RCU panel:

- a. **AZIMUTH INDICATOR:** This 4 inch circular dial and needle indicator displays the azimuth angle of the tracking antenna from 0 to 360 degrees in 1 degree increments (Indicator #11 in Figure E-1).

- b. **ELEVATION INDICATOR:** This 4 inch vertical bar and needle indicator displays the elevation angle of the tracking antenna from -5 to +95 degrees in 1 degree increments (Indicator #12 in Figure E-1).
- c. **AZIMUTH CONTROL SWITCH:** The observer can use this control in any track mode. This is a momentary switch that is routinely in the off position. When toggled up the azimuth moves in a clockwise (CW) direction. When toggled down the azimuth moves in a counter clockwise (CCW) position (Indicator #24, in Figure E-1).
- d. **ELEVATION CONTROL SWITCH:** The observer can use this control in any track mode. This is a momentary switch that is routinely in the off position. Push up the switch to increase antenna's elevation angle (Figure E-1 Indicator #25).
- e. **SIGNAL STRENGTH AND FREQUENCY DISPLAY:** This 4 inch horizontal bar and needle indicator displays either one of two parameters. One parameter is the radiosonde frequency shown from 1655 MHz to 1705 MHz in 5 MHz increments. When the SIGNAL LEVEL/FREQ toggle switch (Indicator #15 on Figure E-1) is set to SIGNAL LEVEL, this display reports the strength of the radiosondes transmitted signal in 10 decibels (dB) increments, from 0 to 110 dB.

15.2 RRS Antenna Tracking Modes. There are three tracking modes that may be used with RRS. They are:

- a. **MANUAL:** Only moves the antenna through commands provided by the operator. These commands may be made by using the CDU or the Antenna Orientation/TRS Display and clicking on the "Slewing Arrows" when entering azimuth and elevation values in the azimuth and elevation windows and clicking the "Move Antenna" button.
- b. **AUTO:** Moves the antenna automatically either from the CDU or the Antenna Orientation/TRS Display. The operator, when using the CDU, should move the antenna close to where the instrument or balloon is sighted and first select "Search". The antenna will lock-on to the strongest signal if the instrument is within the search "Cone Angle" and then transition to "Auto Track" mode.

If the workstation is being used, the operator should move the antenna to the last GPS calculated azimuth and elevation value shown in the "Processed Data" and then move the cursor on the "Search" option and the antenna should find the strongest signal and then switch to the "Auto" track mode. The antenna should also go into "AFC" once it moves to "Auto" track.

- c. **SEARCH:** This mode is used by the operator when using the CDU or workstation once the antenna is pointed to the approximate balloon position. The

“Search” mode will only work if GPS is being received. If the instrument is not found, it will go to a “Full Search” routine that does a 360 degree search beginning at 90 degrees elevation and works gradually down at 5 degree increments until the instrument is found.

Note: The “Full Search” routine should be avoided unless the balloon is directly overhead.

15.3 Receiver Searching Modes.

15.3.1 RDF Receiver Search Modes.

15.3.1.1 Limited Search Mode. When the Limited Search button is pressed or the signal is lost, the RDF receiver is placed into a limited search. Typically in the range of +/-5 MHz about 1680 MHz or about the last viable frequency that was being tracked. When the signal is found and the signal is strong enough, automatic lock is acquired and the AFC lamp should light.

15.3.1.2 Full Search Mode. When the “INITIATE” button is pressed or the signal is lost, (See position #23 on Figure E-1) a full search will not be initiated until after a limited search has been completed. In full search, the RDF receiver goes into a full sweep of the 1655 to 1705 MHz band. The indicator lamp lights up. The time required to locate an instrument using “Full Search” may take as long as 40 seconds.

Note: Usually the need to go into full search should not occur unless a large frequency jump has occurred due to jarring of the instrument at release. Another cause is antenna-loading. This occurs when the observer places the instrument on the ground prior to release. Placing the instrument on the ground causes the frequency to jump or increase. The frequency will drop suddenly when the instrument is lifted off the ground. This sudden frequency change creates a signal loss and causes the antenna to go into the search mode. The period of time it takes the signal to be reacquired is dependent on the amount of frequency change.

15.3.1.3 Manual Search Mode. When the button is depressed (position #18, on Figure E-1), the RDF system’s receiver is disengaged from an automatic search mode (e.g., limited or full search).

If a radiosonde side-lobe signal has been tracked, intermittent signal drop-out may occur and at Lockheed Martin Sippican sites. MicroART will assign low quality values (Q values) for the received signal. If this occurs, then the tracking antenna and/or the receiver’s automatic modes may need to be manually disengaged and manually repositioned using the clinometer and the wind rose if the instrument is visible or use the information provided from upper wind charts and Velocity Azimuth Display (VAD) wind profile off the Weather Service Radar (WSR-88D) console.

The following indicators and controls need to be monitored and/or operated to affect a sweep or search of radio frequencies in the 1655-1705 MHz band:

- a. **FREQUENCY INCREASE/DECREASE Switch:** This toggle switch is usually off. When pushed and held in the INCREASE position, receiver frequency is increased. When it's pushed and held in the DECREASE position, receiver frequency is decreased (This is position #19 in Figure E-1).
- b. **SIGNAL/FREQUENCY Meter:** The operator needs to closely monitor this meter in order to determine the occurrence of strongest signal strength as a function of the manually input receiver frequency.
- c. **LOW SENSITIVITY Indicator Switch:** When either the Remote Control Unit or the Master Control Unit is first powered on, the system is designed to automatically lower the receiver's sensitivity. This low sensitivity state is indicated by the yellow lamp (position #16 in Figure E-1) being lit. Press this button to toggle the switch to high sensitivity (the lamp goes dark).

15.3.2 RRS Receiver Search Modes. Searching/ scanning to find the radiosondes frequency may be accomplished from the CDU or at the RRS workstation using the "Antenna Orientation/TRS Display".

15.3.2.1 Manual Search Mode. Using the CDU to manually find the radiosondes frequency or set the frequencies may be accomplished using a couple of different techniques.

Steps to manually move the frequency using the CDU:

Method 1:

- a. Press the "REC" key, a menu will appear and select "4: Trk on" key (See Figures E-2 and E-3).
- b. Use the Up and Down arrows on the CDU to move the frequency in the desired direction. Using the "O/fast" key will allow the frequency to change more rapidly if a large frequency change is required. Monitoring the value to the right of "SIG" on the display window will provide a direct display when the radiosonde signal is found.

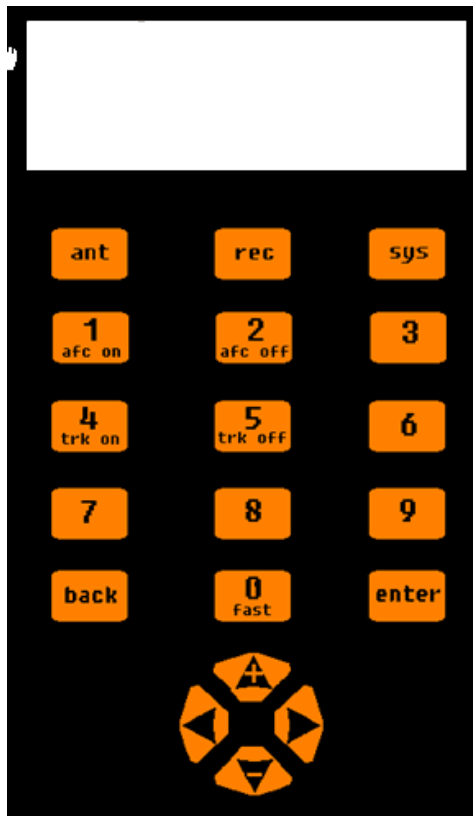

Figure E-2 – Console Display Unit (CDU)

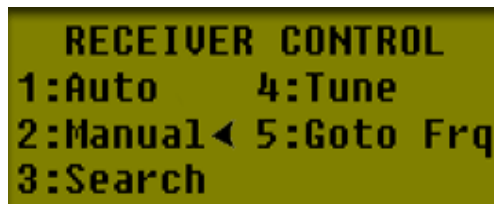

Figure E-3 – Receiver Display

Method 2:

- a. Press the “REC” key, a menu will appear and select “5: Goto Frq” key (See Figures E-2 and E-3).
- b. Use the Up and Down arrows on the CDU to move the frequency in the desired direction. Using the “O/fast” key will allow the frequency to change more rapidly if a large frequency change is required. Monitoring the value to the right of “SIG” on the display window will provide a direct display when the radiosonde signal is found.

Using the RRS workstation, with the “Antenna Orientation/TRS Display” the frequency may be manually set or moved manually to locate the radiosondes frequency. The receiver has an operating band from 1668.4 MHz to 1700.0 MHz. The NWS is authorized only to operate from 1675 MHz to 1690 MHz.

15.3.2.2 Auto Search Mode. The best method for acquiring the signal automatically with the receiver is to press the “TRK ON” key. This will initiate searching features within the TRS. If prescribed conditions are met, (Wide Angle Gathering Sensor) WAGS tracking starts. This is generally used when the radiosonde is closer to the TRS and the signal strength is higher. When the radiosonde moves farther away from the TRS and the signal strength is lower, the system transitions into (Narrow Angle Gathering Sensor) NAGS tracking.

- a. Press the “REC” key, a menu will appear and press the “3: Search” key (See Figures E-2 and E-3).
- b. Two screens will appear. The first screen shows the (lower) frequency of the search. The value entered here is stored for recall as the initial value for this entry screen the next time that a frequency search is requested. Press the “Enter” key to proceed.
- c. The second screen that appears is the (upper) frequency of the search. These are defaults that are set to the limits of the receiver. (1668.4 MHz and 1700 MHz) Sites may change the limits to those the NWS is authorized to operate within 1675 MHz to 1690 MHz. If the upper limit looks fine, go ahead and press the “Enter” key.
- d. A search will initiate. When the search begins, the AFC is turned off, a screen shows the current frequency and signal strength numerically and graphically. Press the “Enter” key when the radiosondes signal is located. The receiver holds the last frequency and the CDU will revert back to the idle State. If the receiver is not in AFC, go ahead and press the “1: AFC On” key.

16. Successful Release Criteria.

16.1 MicroART Observation. A successful radiosonde release will be verified by the MicroART software when examining the first few minutes of data of the observation. A successful radiosonde release is based on the following criteria:

- a. The pressure decreases for 2.8 of the first 3.0 minutes.
- b. Temperature is present for at least 1.0 minutes of the first 5.0 minutes of the observation.

A and b are satisfied. If these requirements are met, the launch is considered successful and the observation continues. If they are not met the observation will be considered unsuccessful, the observation will be terminated. Once authorization for a second release is obtained, preparations

for another release should get underway immediately.

16.2 RRS Observation. A successful radiosonde release will be verified by the RRS software when examining the first few minutes of data of the observation. A successful radiosonde release is based on the following criteria:

- a. The pressure decreases for 2.8 of the first 3.0 minutes.
- b. Temperature is present for at least 1 minute of the first 5.0 minutes of the observation.
- c. Temperature or pressure can not be missing for 3.0 or more consecutive minutes.

A, b and c are satisfied. If these requirements are met, the launch is considered successful and the observation continues. If they are not met, the observation will be terminated. When authorization for a second release is obtained, preparations for another release should get underway immediately.

17. Multiple Releases. Observers that have a failed release decide if they have a local requirement for another release. This decision should be made by the senior meteorologist on-duty. If a site does not have a meteorological need for the data, they then call the Senior Duty Meteorologist (SDM) at NCEP and inquire if NCEP needs another release. Under no circumstances, will a station attempt more than 3 releases to obtain a successful observation.

17.1 The Second Release. Each upper air station should track the radiosonde to the highest altitude possible. Care is taken to ensure the observer checks and verifies the data is realistic and reasonable. Software data check messages should be investigated and unrealistic data edited or eliminated prior to message transmission. If a radiosonde terminates before reaching 400 hPa, a second release may be required. When necessary, the second radiosonde should be released as promptly as possible in order to stay within the time limits of the scheduled observation (see “Delayed Release” Section 13.4, for procedures). However, if because of unfavorable atmospheric conditions or other reasons, it is apparent that a pressure equal to or less than 400 hPa cannot be attained in subsequent attempts, an additional release should not be made.

If a second release is not made and the record from the first one has usable data, even though it did not extend to a pressure equal to or less than 400 hPa, the record from the first release should be assigned an ascension number and transmitted to NCEP and NCDC.

When a second release is required but not made, the reasons for the omission should be stated fully in the “Remarks” section of the WS Form B-29, Rawinsonde Report. If a second and succeeding release does not reach the required minimum altitude, the ascension providing the greatest amount of good quality data should be the official observation. If neither observation provides useful data and a third release is not authorized, the observation will be logged as missing.

17.2 The Third Release. If observation equipment or ground equipment fails on the second

release and results in the premature termination of the observation, a third release may be initiated if authorization is granted. The third release however, marks the limit for the number of attempts to complete a scheduled synoptic observation. No further attempts will be made if the third release fails to meet the successful observation criteria. If this release attempt fails, data from the single most complete observation should be disseminated unless missing temperature data exceeded the tolerances specified in Table E-5 for all release attempts. In this case, a missing observation should be reported. See section 21 for more information.

18. Observation Success. In order for an observation to be successful, all criteria for a successful release (see Section 16,) is first met to satisfy the MicroART and RRS software. The observation is finally deemed successful when the upper air observation contains at least the required amount of data per three strata and has not had more than 6 minutes of missing data from surface through 400 hPa. If the observation was not terminated for the reasons specified in Table E-5 and has not failed, the observation is deemed successful.

If a radiosonde observation has to be terminated early (see reason for early termination in Appendix G) initiate procedures described in Appendix D (Pre-Observation Preparations) to prepare a second observation if authorized. This ‘second release’ will acquire data for the same synoptic reporting hour as the first observation.

To distinguish among multiple observations launched to obtain a given site’s synoptic observation, MicroART requires a release number (e.g., 1, 2, or 3) to be entered. NOTE: A release number of 0 may be entered for test observations. A range error (release number greater than 3) warning will be displayed, but may be overridden by the observer. The RRS software automatically assigns a release number 1 to observations having an unused ascent number. If the observation should terminate prior to being successful or terminated by the observer, the software will prompt if another release is desired and mark the next release with the appropriate release number in the data file.

An observation is deemed successful when reliable data from the surface to at least the 400 hPa level has been recorded. Sites using Lockheed Martin Sippican instruments receive meteorological data with quality values (Q-values) which can be seen in the MicroART software. Sites using the Lockheed Martin Sippican radiosondes, the Q-values of 30 or more are valid. Data with Q-values less than 30 are invalid or unreliable and the software will mark them missing. Sites using the Lockheed Martin Sippican GPS radiosondes the Q-values are 100 if received and 0 if missing. The maximum permissible quantity of missing temperature data is provided in Table E-5.

An observation should be terminated when the number of minutes of missing, or observer deleted, temperature data as given in Table E-5, are exceeded. Observer edits are not considered by the software. Table E-5 represents the maximum tolerable amount of missing data, expressed in both strata thickness and time interval.

Pressure Range	Strata Thickness	Minutes of Missing Data
----------------	------------------	-------------------------

(hPa)	(km)	(minutes)
Surface to 700	1	4
Surface to 400	2	6, with above criteria satisfied
Surface to 100	3	12, with above criteria satisfied
Surface to termination	5 (Upper < 100 hPa)	16, with above criteria satisfied

Table E-5 Termination Due to Missing Temperature Data

Note: Table assumes a balloon ascent rate of 300 meters per minute.

19. Reasons for Missing Data.

19.1 Weak Signal. Weak or fading signals can result from defective radiosonde components, i.e battery, a radiosonde moving too far away, or a ground tracking antenna that is not correctly locking onto the radiosonde signal.

19.2 Interference. Signal interference has become a problem especially at sites located near large metropolitan areas. Abrupt change in the audio or frequency is a good indicator of possible interference. Signal interference with the GPS radiosonde is less of a problem due to a signal that usually does not drift more than $\pm .1$ MHz during an observation and the signal is less than 350 KHz in width.

19.3 Sensor Failure. Radiosonde sensors may fail. If the relative humidity sensor fails the observation can be continued if the relative humidity is not considered critical for forecast operations. If the temperature or pressure sensor fails, the observation will be automatically terminated at the last reliable data point.

19.4 Other Causes: In the event that the quality of the telemetered data becomes questionable, the ascent may be terminated.

19.5 Successful Observation - Some Missing Data. Whenever a stratum of missing temperature data is followed by satisfactory data, the observation is continued provided the stratum or strata of missing data does not exceed the limits in Table E-5 (for “Surface to 700 hPa” and “Surface to 400 hPa”). When the limits are exceeded in one stratum of missing temperature data, the observation is terminated at the base of the stratum.

19.6 Unsuccessful Observation - Sum of All Missing Data. Whenever the limits for “Surface to 700 hPa” or “Surface to 400 hPa” in Table E-5 are exceeded (not considering observer edits), the observation should be terminated at the base of the stratum in which the limits are exceeded.

NOTE: Observers should be aware that MicroART and RRS software will only terminate the observation for data the software deems missing or was rejected. Additional data that the

observer deletes will not be taken into consideration by the software program. The observer is responsible to ensure that the criteria in Table E-5 are not exceeded.

20. Unscheduled Observations. Unscheduled or special observations are those performed outside the standard times of scheduled synoptic observations (see Section 2, Synoptic Schedule Requirements). Special observations may be requested by either NCEP (e.g., Storm Prediction Center), or in support of special projects authorized by WSH or Regional Headquarters. Each NWS upper-air site will adhere to all the basic requirements for synoptic observations except for cases of severe weather, equipment limitation, or other factors that warrant early termination. Special observations will be transmitted and archived in the same manner as scheduled synoptic observations.

21. Missed Observations. A missed observation is defined as a 00Z or 12Z observation where no upper-air data are available for transmission to NCEP and NCDC. This would occur when:

- a. The ground equipment is broken and no radiosonde can be released during the required observation time.
- b. A radiosonde was released, but no data was received or the data was unreliable. A second (or third) release was not authorized or those releases provided no useful data.

Note: If a small amount of good quality upper air data is available (e.g. 650 millibars (mb)) and this was the only observation authorized, then the observation will be given an ascension number and transmitted to NCEP and NCDC. The observation will not be logged as missed. If the observation is missed, the observer will transmit coded messages notifying data users that no observation is available.

APPENDIX F – OBSERVATION PROCEDURES AND DATA TRANSMISSION

<u>Table of Contents:</u>	<u>Page</u>
1. Introduction.....	F-1
2. Checking Signal Strength and Lock-on.....	F-2
2.1 MicroART and MCU Checks.....	F-2
2.2 RRS CDU and Workstation Checks.....	F-2
2.3 Tracking Problems.....	F-2
2.3.1 RRS Signal Problems.....	F-2
2.3.2 Frequency Problems.....	F-3
2.4 Routine Checks.....	F-3
2.4.1 MicroART Check.....	F-3
2.4.2 RRS Check.....	F-4
2.5 Observation Check Parameters.....	F-4
2.5.1 MCU Check for the RDF System.....	F-4
2.5.2 RRS Workstation Checks.....	F-5
3. Corrective Actions.....	F-5
4. Balloon Overhead.....	F-6
5. Unsuccessful Observation.....	F-6
5.1 Missed Synoptic Observation.....	F-7
5.2 No Data above Surface Available.....	F-8
5.3 Data above Surface Available.....	F-8
6. Second Releases.....	F-9
7. Data Checks.....	F-9
8. Transmission of Observations.....	F-10
9. Coded Messages.....	F-10

Tables

F-1 Deadlines for Transmitting Upper-Air Data.....	F-10
--	------

1. Introduction. After a successful balloon train release the observer will follow procedures to ensure a successful observation and timely dissemination of the upper-air data. This appendix

and either the MicroART Training Guide or the RRS User's Guide provides observers with the correct procedures.

2. Checking Signal Strength and Lock-on.

2.1 MicroART and MCU checks. After return from the balloon release point, the observer should check the MCU readings and MicroART computer displays. If the signal strength is strong and the observer is confident the antenna is locked on the main signal, the position data should be checked to determine when lock-on occurred and delete all position data up to that point. The observer should keep the audio turned up loud enough to monitor the instruments tones and check for interference or signal loss.

2.2 RRS CDU and Workstation Checks. The observer, prior to release and after release, verifies the frequency and signal strength by using the Console Display Unit (CDU). The check prior to and after release with the CDU allows the operator the opportunity to reacquire the frequency or signal if lost. If the CDU is inoperative or the weather is inclement, the observer may have to wait until returning to the office to use the workstation to ensure the system is tracking effectively. The observer should utilize the RWS status bar and Antenna Orientation/TRS Display on the workstation to verify equipment tracking and the signal strength after returning to the office.

2.3 Tracking Problems. Rapid loss of signal strength or quality, major fluctuation in angular readings, or shift in frequency should be looked at closely.

- a. Turning up the audio with the RDF tracking system will allow the observer to monitor the signal quality and tones essential for the early portion of the observation where the chance of getting on a side lobe or another signal is most likely.
- b. The RWS has an audible alarm if data goes missing for 1 minute and will alarm again at 2 minutes.

If it is apparent that a significant change has occurred and the antenna is not tracking on the signal, the observer should take immediate action by checking the antenna position and signal strength. Depending on the observer's analysis, either the antenna or the frequency will have to be adjusted.

2.3.1 RRS Signal Problems. If the signal strength drops with the tracking system, verify that "AFC" is on and that the TRS is tracking or pointed in the correct direction. If the signal can not be found, press the "Manual Tracking" button and move the antenna to the probable direction by noting the previous tracking prior to signal loss. This may be accomplished by going to the Processed Data and looking at the last good GPS calculated azimuth and elevation data points. Also keep in mind the wind flow in the atmosphere. This may be accomplished by looking at the current WSR-88D wind profile or looking at upper-level wind charts. RRS allows the operator to click the "Search" button to relocate the radiosonde. If GPS is being received, the "Search" button should point the antenna to the last known GPS location. If no GPS is received, the

observer should move the antenna to the last known position or use the upper level charts to move the antenna then, click on the “Search” button in the TRS/Antenna Display. This will initiate a limited conical search.

2.3.2 Frequency Problems. If the frequency has made an abrupt shift or significant change since the release, determine if the signal being received is the radiosondes. RDF sites should turn up the speaker volume and listen for the instrument tones. If the signal is not from the instrument, the observer should immediately press the “Manual Search” button and toggle the frequency down in the direction where the signal was originally, stopping once the signal is acquired and pressing the “AFC” button to have the equipment automatically begin tracking the signal. If the signal should again track off the instrument’s frequency, it may become necessary to leave the tracking in a “Manual Search” until the other signal no longer interferes with signal acquisition.

Also the observer should determine that the signal being tracked is from the main lobe and not from a side lobe. This can be determined by looking at the signal strength and listening to the signal’s audio output if tracking with the RDF tracking system. If the signal is weak or scratchy, the observer may want to go into “Manual Tracking” and adjust the elevation and azimuth manually to ensure the signal is the main signal.

Sites using GPS radiosondes and the RRS tracking system should have fewer problems with frequency shifts and interference. Drift for the transmitter is less than .2 MHz during the observation and interference is limited due to the narrow bandwidth. If the signal is lost, the operator may locate the frequency by using the “Scan” button on the Antenna Orientation/TRS Display window or change the frequency manually by clicking on the up or down arrows or clicking on the “Set” button and typing in the frequency desired.

If there has been an unexplained shift, the observer should write down the time that it occurred and continue to monitor the observation by keeping the RDF audio turned up. This information should be communicated to the Regional Upper-Air Program Manager for help in determining possible problems with radiosonde production lots. The observer should also include the radiosonde serial number and the shipment number.

2.4 Routine Checks.

2.4.1 MicroART Check. MicroART will prompt the observer to enter the time the RDF equipment locked on the radiosonde after release. Chapter 9 of the MicroART Training Guide provides instructions on how to properly determine the correct time. The standard procedure would be to enter 0.0 minutes and then look at the positional data to determine when lock-on occurred. If the data are edited accordingly, follow the procedures in the MicroART Training guide for processing and handling of the data. During the observation, periodically (at least every 15 minutes) check the MicroART computer displays for problems.

If there are data problems, MicroART will typically provide alerts along with status messages and/or a red flashing Loss of Signal (LOS) display. Chapters 9 and 14 of the MicroART training guide show the types of data problems that may be encountered and the procedures for checking

and editing the upper-air data. If the LOS alert persists, check the MCU readings to help determine the cause.

2.4.2 RRS Check. The RRS software determines the release by a pressure change algorithm. Positional data is determined by GPS lock and not from where the TRS is pointing.

2.5 Observation Check Parameters.

2.5.1 MCU Check for the RDF System.

At the MCU panel, check the following:

- a. Signal strength - Within 5 minutes after release, the signal strength should typically be above 60 db. If not, refer to Section 2.3.1.
- b. Received frequency - The AFC should be set to Auto and the received frequency should be within 5 MHz of what it was during baseline. If the frequency has shifted, refer to Section 2.3.2.
- c. Audio signal - Should sound clear without noise. If it's weak or noisy, refer to Section 2.3.1.
- d. RDF tracking motors - Tracking motors are off Stand-By mode and the angular data display is showing changing angular values.
- e. Elevation angles - If angles exceed 80 degrees, follow the procedures in Section 4 for handling overhead balloon conditions.
- f. Tracking mode - Should be set to the Near Auto mode. After about 15 minutes into the observation, set the tracking mode to Far Auto. However, if the balloon train is overhead leave the tracking in Near Auto until the elevation angle drops below 60 degrees.
- g. Low Sensitivity switch - Should be turned off, unless the balloon train is overhead. See Section 4 for handling overhead balloon cases.

If there are no problems, continue to the procedures in the MicroART Training guide for processing and handling of the data. During the observation, periodically (at least every 15 minutes) check the MCU readings for problems and data check messages on the MicroART computer.

2.5.2 RRS Workstation Checks. At the RRS workstation check the following:

- a. Signal strength – Within 5 minutes after release, the signal strength should typically be above 50 db. If not, refer to Section 2.3.1.
- b. Received frequency - The AFC should be ON and the received frequency should be within .2 MHz of what it was during baseline. If the frequency has shifted, refer to Section 2.3.2.
- c. RRS tracking motors - Tracking motors are in Auto mode and the angular data display in the Processed Data is showing changing angular values. The angles shown in the processed data are GPS calculated and may not show changing angular values if GPS is not received. Verify GPS azimuth/elevation compare with TRS azimuth/elevation.
- d. Azimuth and Elevation angles - If not locked-on and if GPS is received, click on the “Search button. If no GPS, move the antenna to approximate direction and azimuth and Click the ‘Search’” button. This will initiate a limited conical search. AFC will be turned off, but will come on by itself once the Telemetry Receiving Antenna (TRS) is locked-on to the radiosonde and back in “Auto” track mode.
- e. Tracking mode - Should be set to the Auto mode.

If there are no problems, follow the procedures in the RRS Users Guide for processing and handling of the data. During the observation, periodically (at least every 15 minutes), check the workstation status and data messages.

3. Corrective Actions. If the signal strength is weak or noisy, or there is a major shift in the radiosondes frequency, there is either a problem with the radiosonde or ground equipment. Sometimes these problems will go away as the observation progresses or the problems will get worse possibly resulting in the termination of the observation due to missing or bad data. If the observer notices these or similar problems check the following:

- a. Make sure the RDF equipment is not tracking a "side lobe" Chapter 14 of the MicroART Training Guide provides procedures for identifying side lobe tracking. If it is determined side lobe tracking is occurring, set the tracking mode to manual. Gradually adjust the elevation and azimuth angles until a significant increase in signal strength occurs. Reset the tracking mode to Near or Far Auto and follow the procedures in Chapter 14 of the MicroART Training Guide for editing the angular data.
- b. Check the elevation angle. If it is over 80 degrees follow the procedures in Section 4.
- c. Check the radiosonde frequency. If the frequency shift becomes so severe that the RDF Automatic Frequency Control (AFC) can not find or track the radiosonde

signal, try setting the AFC to manual and sweep the frequency until it locks onto the radiosonde. Reset the AFC to Auto.

- d. Closely monitor the observation data until the balloon train reaches at least 400 hPa. If the problems cause the observation to terminate before this level, follow the procedures for making a second release (Section 6).
- e. If problems persist from one observation to the next, there may be problems with the ground equipment or the way the radiosonde is prepared and/or how the balloon train is released (e.g., rapid shift in frequency may be a result of a poorly prepared/handled radiosonde).

If it is determined that the observer's actions are not a cause for the problems, the station Electronics Technician should check the equipment.

4. Balloon Overhead. Depending on the system, different methods can be used:
 - a. RDF - In a situation where the balloon will likely go overhead with the RDF tracking equipment, the observer should press the "Near Auto" switch. This will allow the equipment to track the balloon as it makes angular changes more rapidly. The observer should closely monitor the elevation and azimuth angles. If the balloon is going overhead, the operator should press the "Manual Search" indicator and manually position the antenna using the past observed movements to determine the trend and which direction the instrument is tracking. This condition may require some delicate adjustment, but once the signal strength is regained go back into "Near Auto" tracking. Continue using "Near Auto" tracking until the elevation angles decrease to less than 60 degrees.
 - b. RRS- When using the RRS tracking equipment, overhead conditions or rapidly changing elevation or azimuth angles may cause the antenna motor current to increase and generate a TRS Status message if the conditions exists for more than four seconds. The movement of the TRS will be suspended for eight seconds. The Status Message that comes up for the TRS is the 'MCU: 0x0800' error. When a MCU error message is received, the operator should verify the antenna position and movement. If the antenna is moving rapidly or at high elevation angles, place the antenna in manual tracking until GPS calculated the azimuth and elevation angles shown in the Processed Data decrease in elevation or show less movement.

5. Unsuccessful Observation. On occasion, an observation will terminate before reaching 400 hPa. This is deemed an unsuccessful observation because insufficient data was collected. MicroART and RRS may automatically terminate the observation early or the observer may terminate the observation manually for a number of reasons. Appendix G of this manual and Chapter 11 of the MicroART and RRS Training Guide provide reasons for observation termination.

Observations are deemed a failure if one or more of the following occurs:

- a. The balloon fails before reaching 400 hPa.
- b. The amount of missing temperature data exceeds 4 minutes between surface and 700 hPa and 6 minutes from surface and 400 hPa.
- c. The quality and accuracy of the pressure and/or temperature data are deemed poor either automatically by the software or by the observer.

Before proceeding with a second or third release do the following:

- a. Do not attempt a release if the problem (e.g., ground equipment failure, inclement weather) that caused the observation failure cannot be corrected or mitigated before the next release is made.
- b. Ask the lead forecaster if another release is required. If the site does not have a requirement, the Lead Forecaster (LF) contacts the SDM at NCEP and let him/her know. If the SDM believes another release is required for national purposes, the LF should authorize the release. If a second release is not required, follow the procedures for terminating an observation in Appendix G of this manual, Chapter 15 of the MicroART Training Guide, and Chapter 9 of the RRS User Guide.
- c. Review procedures in Appendix E, sections 17-19.

5.1 Missed Synoptic Observation. If an observation fails with no usable data and the 2nd and 3rd releases provide no usable data either, the observation will be logged as missed. The observer will manually code the TTAA, TTBB and TTDD messages (RRS will code it for you) with appropriate 101xx groups. Coding PPBB, TTCC, and PPDD messages are not required. See 101 codes page F-14. Some good examples of proper coding are:

- a. Ground equipment failure and no observation is required- use 51515 10142 10148. 10142 represents the code for **ground equipment failure** and 10148 represents the code for **ascent not authorized for this period**.
- b. Due to a late launch and the sounding is nearing the Model run time (0100Z/1300Z)* the station should send the data that is available. Use 51515 10141, 10141 represents the code for **incomplete report, full report to follow**.

*Note: 0115Z and 1315Z are model run times. Allow sufficient time for the observation to cycle through the communication system.

5.2 No Data above Surface Available. If an observation fails at release and no data above surface is available, the observer should manually code the TTAA, TTBB, TTDD messages. The TTCC message does not need to be sent. Allowing MicroART to automatically code the data will cause improper messages to be sent out with // for all met and wind data.

The RRS software will code a “No Data Message”.

(See examples of manually coded messages below)

AWIPS Message: USUS41 KLWX 250000
MANIAD
72403 TTAA 7500/ 72403 51515 10142=

Alaska Message: UMAK48 PAFC 250000
SGLAFC
70273 TTBB 7500/ 70273 51515 10145=

Pacific Message: /C UJHW2 PHTO 250000
91285 TTDD 7500/ 91285 51515 10144=

- * Pacific and Alaska Region may be using a slightly different header format or change the header format at a later date. Sites should check with the Region Upper-Air Program Manager or the Regional Communication Manager for format questions.

NOTE: There are two different procedures to follow when an observation is missed.

- a. When an observation is not possible for any reason (MicroART) - The observer should manually code the messages using the proper 101 group which signifies the reason for no data. RRS has a “No Data” Option under the “Messages” dropdown.
- b. When an observation is missed and another was possible, but not authorized - The observer should add a 10148 group after the 51515 message to the TTAA, TTBB and TTDD messages. The 10148 group signifies that an ascent was not authorized. The 10148 group should only be used when a second release is possible, but not allowed by NCEP or other approving authorities.

5.3 Data above Surface Available. If a release or multiple releases were made and some data above surface was acquired and considered accurate, the observer will transmit the data from the observation containing the greatest amount of reliable data. If the observer attempts another release, but it fails, and the initial observation data will be transmitted, the observer should go to the ‘ART Options’ Menu in MicroART and select ‘Resume’ using the log diskette from the initial observation. When the data has been transmitted the observation will be given an ascent number and the data will be archived.

RRS allows the operator to select another release if an observation does not reach 400 hPa. It

will save the initial observation data and can be used if the subsequent releases are not allowed, fail or have less data.

A successful observation requires an ascent to 400 hPa or higher, however if upper-air good quality data above the surface is obtained and a second release is not possible or authorized the data acquired will be used. The observation is assigned an ascent number transmitted to NCEP and archived if the data is transmitted.

6. Second Releases. If a second release is authorized, observers will do the following:
 - a. **MicroART:**
 - (1) Terminate the observation by pressing the red Stop Print button on the MCU.
 - (2) Follow the procedures in Chapters 15 of the MicroART Training Guide.
 - (3) Follow the procedures in Appendices I and N of this manual.
 - (4) While preparing the next radiosonde release, tune the frequency at least 5 MHz away from the frequency of the previous radiosonde. This applies if the previous radiosonde is still airborne and transmitting a signal.
 - (5) If the second release fails, follow the instructions in sections 5 through 5.3 if no additional release is authorized.
 - b. **RRS:**
 - (1) Terminate the observation using the “Flight” option if the software has not terminated the observation. When the software asks if you want to turn off the UPS select “NO”.
 - (2) When asked “Do You Wish to Do Another Release” click the “Yes” button.
 - (3) Follow the procedures in Chapter 8 of the RRS User Guide.

7. Data Checks. High quality upper-air observations are critical for NWS forecasts and warnings. None of the NWS upper-air ground Systems now and into the foreseeable future is expected to eliminate the observer’s requirement to edit and correct data. **All observers will be proficient in determining data accuracy.** The software provides status messages, checks and alerts to the observer of flagged errors or potential problems. The observer will monitor these notices and check the data that has been flagged or identified as having possible problems or inconsistencies. **Checking the quality and plausibility and editing the upper-air data as necessary, are an essential part of the duties of an upper-air observer.** The observer makes every effort to identify and edit erroneous data before it is disseminated. NCEP and NCDC data

quality control systems will not detect all data errors.

Chapters 9 and 14 of the MicroART Training Guide and Chapters 9 and 13 of the RRS User Guide provide procedures for identifying and editing data errors. The software does not automatically edit or delete erroneous data. It only alerts the observer to questionable or erroneous data. The observer reviews and edits data before it is disseminated. Remember, the observer is responsible for the accuracy and timeliness of the observation.

8. Transmission of Observations. Once the observer has checked the quality of the data, follow Chapter 10 of the MicroART and RRS User Guide for transmitting the coded messages. These data will be transmitted through the telecommunication system in as timely a manner as possible. Failure to transmit the observation on time will result in the data not being ingested into one or all of the numerical weather prediction models. The deadlines for transmitting the coded messages are shown in Table F-1.

H is the time at either 00:00 or 12:00 UTC

Part A:	H + 1 hour
Part B:	H + 1 hour
Part C:	H + 2 hours

Table F-1 Deadlines for Transmitting Upper-Air Data

On a typical observation lasting 100 minutes, the Part A and B messages are ready for transmission at about H + 15 minutes and the Part C and D messages are ready at about H + 40 minutes. If the observer has other office duties to perform away from the upper air computer, the data should be checked and transmitted at the above times. If time is short owing to a delayed release or second/third release, at a minimum check and transmit Part A and Part B messages as soon as possible.

9. Coded Messages. The observer understands how to properly code and decode upper-air messages. The messages for the sites in the continental United States, Alaska, the Bahamas, and the Caribbean are in WMO Region IV. The sites in the Pacific Region are in WMO Region V. The coding practices differ slightly in Region IV and V, the difference being the stability index and mean low level winds are not computed for sites in Region V. Coding at RDF sites will show this difference. It has been determined to code using Region IV practices for all RRS sites.

CODED MESSAGE BREAKDOWN

91285 TTAA 56001 91285 99011 28060 01009 00107 24856 01007
 92787 20456 33502 85514 18265 22504 70145 07413 27011 50586
 04170 33025 40758 17367 32025 30966 32764 30537 25092 40762
 30545 20241 52560 30541 15421 67158 30024 10657 79756 32024
 88999 77999 51515 10164 00011 10194 32003 23507=

IIiii TTAA YYGGI_d IIiii 99PPP TTTDD dffff 00hhh TTTDD dffff
 92hhh TTTDD dffff 85hhh TTTDD dffff 70hhh TTTDD dffff 50hhh
 TTTDD dffff 40hhh TTTDD dffff 30hhh TTTDD dffff 25hhh TTTDD
 dffff 20hhh TTTDD dffff 15hhh TTTDD dffff 10hhh TTTDD dffff
 88PPP 77PPP 51515 10164 000I_sI_s 10194 dffff dffff=

IIiii - Block number and station number.

TTAA - Indicator of mandatory levels up to 100 hPa.

YYGGI_d – YY, day of the month indicator, if winds are in knots 50 is added.

GG, actual time of the observation to the nearest hour UTC.

I_d, indicator of the level for winds in parts A and C in hectopascals.

YY - Day of the month, (When winds are given in knots 50 will be added to YY).

GG - Actual time of observation, to the nearest whole hour UTC.

I_d - Indicator used to specify the pressure relative to the last standard isobaric surface for which a wind is reported. Reported to the nearest hundreds of hectopascals, (Used in TTAA and TTCC).

PPhhh - Mandatory pressure levels.

PP - Starts with 99 - indicating surface 00 -1000 hPa 92- 925 hPa 85 - 850 hPa on until 10-100 hPa.

hhh - Height in geopotential meters (gpm).

Sfc to 500 hPa - Reported in whole gpm (thousands not reported) 3204 gpm reported 204

500 hPa to Term - Reported in tens of gpm 6053 gpm reported 605.

TTTDD - Temperature and Dewpoint Depression Values.

TTT - Dry bulb temperature in degrees Celsius. Last digit indicates if the temperature is negative or positive. Negative temperatures will have an odd number for the 3rd digit. Positive temperatures will have an even number for the last digit.

DD - Dewpoint depression - This number is subtracted from the dry bulb temperature. Numbers

of less than 55 are degrees and tenths. (i.e) 49 is 4.9 degree dewpoint depression. Numbers of 56 or greater are dewpoint depressions in whole degrees. To obtain the proper dewpoint depression value subtract 50 from values 56 or greater. (i.e) 72 would be a dewpoint depression of 22 degrees.

ddfff - Wind Direction and Speed.

dd - True wind direction to the nearest 5 degrees. Wind direction is rounded off to the nearest 5 degrees. (i.e., 293° is rounded to 295°, 292° is rounded to 290°)

fff - Observed wind speed in knots. When the rounded wind direction is 5°, 500 is added to the wind speed; when the rounded direction unit is 0°, the wind speed is coded directly. (i.e., 27020 is the wind from 270° at 20 knots; 27120 is the wind from 270° at 120 knots; 27520 is the wind from 275° at 20 knots; 27620 is the wind from 275° at 120 knots.)

88hhh - TTTDD 88 - indicates tropopause.

77hhh - ddfff 77 - indicates max wind group.

51515 - Regional Code Groups Follow.

10164 - Indicator for the stability index that follows.

10194 - Indicator that the mean low level wind groups follow.

ddfff ddfff - First group mean winds sfc - 5000 feet.
 Second group mean winds 5000 - 10000 feet.

= (End of message symbol) It is a telecommunications character and is not part of the code.

91285 TTBB 56000 91285 00011 28060 11008 26057 22000 24856
 33905 19057 44850 18265 55795 13257 66768 12260 77764 12039
 88700 07413 99679 05817 11675 06259 22670 06661 33652 06061
 44644 05666 55627 03462 66606 02068 77567 01163 88548 01271
 99478 05769 11339 28364 22281 34763 33137 71358 44100 79756
 31313 01102 82307 41414 59571=

IIiii TTBB YYGGa4 IIiii 00PPP TTTDD 11PPP TTTDD 22PPP TTTDD
 33PPP TTTDD 44PPP TTTDD 55PPP TTTDD 66PPP TTTDD 77PPP TTTDD
 88PPP TTTDD 99PPP TTTDD 11PPP TTTDD 22PPP TTTDD 33PPP TTTDD
 44PPP TTTDD 55PPP TTTDD 66PPP TTTDD 77PPP TTTDD 88PPP TTTDD
 99PPP TTTDD 11PPP TTTDD 22PPP TTTDD 33PPP TTTDD 44PPP TTTDD
 31313 s_r r_ar_a s_as_a 8GGgg 41414 N_hC_LhC_MC_H=

a₄ - Type of measuring equipment used.

0 - Pressure instrument associated with wind-measuring equipment.

1 - Optical Theodolite

- 2 - Radiotheodolite
- 3 - Radar
- 4 - Pressure instrument associated with wind-measuring equipment but pressure element failed during ascent.
- 5 - VLF-Omega
- 6 - Loran-C
- 7 - Wind profiler
- 8 - Satellite navigation
- 9 - Reserved

Note: a_4 is not fully implemented into the MicroART software - MicroART codes "0" in TTBB & TTDD.

PPP - Pressure of Significant Levels Selected.

SFC to 100 hPa - Levels selected to nearest whole hPa.

Above 100 hPa - Levels selected to nearest 0.1 hPa.

31313 - Data on Sea Surface Temp & Observation System Used.

s_r - Solar and infrared radiation correction.

- 0 - No correction
- 1 - Correction Made

$r_a r_a$ - Radiosonde Used

- 87 - Lockheed Martin Sippican GPS Mark IIA (USA)
- 51 - Lockheed Martin Sippican type B-2 time commutated (USA)
- 52 - Vaisala RS80-57 (Finland)

$s_a s_a$ - Tracking Technique/Status Used

- 00 - No wind finding
- 01 - Automatic with auxiliary optical direction finding
- 02 - Automatic with auxiliary radio direction finding
- 03 - Automatic with auxiliary ranging
- 05 - Automatic with multiple VLF-Omega frequencies
- 06 - Automatic cross chain Loran-C
- 07 - Automatic with auxiliary wind profiler
- 08 - Automatic satellite navigation

- 8 - Indicator
- GG - Hour UTC of release

gg - Minute of release

41414 - Cloud Data $N_h C_L h C_M C_H$

N_h - Amount in eighths of all the C_L present or, if no C_L is present, the amount of all the C_M present.

C_L - Type of low cloud present

h - Height above surface of lowest cloud seen

C_M - Type of middle cloud present

C_H - Type of high cloud present

PPBB 56000 91285 90012 01009 01003 00502 90346 32002 26003
 20502 90789 21005 23508 27013 91245 26512 27016 26514 9169/
 31013 33026 9205/ 32523 32025 93013 31034 31538 29542 935//
 30547 949// 30024 9504/ 30025 32037=

PPBB YYGGa₄ Iiiii 9t_nuuu dffff dffff dffff 9tnuuu dffff dffff dffff=

YYGGa₄ Iiiii dffff - Previously described

9 - Indicator to show winds in units or 300 meters or 1,000 foot increments

t_n - Indicates tens digit of altitude - 0 = less than 10,000 feet 1 - 10,000 - 19,000 feet

u - Indicates the unit value of altitude of winds

91285 TTCC 56002 91285 70858 76757 05508 50059 63959 11005
 30378 54160 06009 20638 51161 07512 88922 82356 33014 77999=

TTDD 5600/ 91285 11922 82356 22700 76757 33517 64359 44472
 64959 55364 57560 66130 47162=

PPDD 56000 91285 9556/ 32522 33015 970// 13004 98047 08012
 09512 07012 99015 08012 08011 05005=

Breakdown for 101A_{df}A_{df} - Miscellaneous Regional Data

<u>Code Figure</u>	<u>Definition</u>
40 - 59	Reason for no report or an incomplete report
40	Report not filed
41	Incomplete report; full report to follow
42	Ground equipment failure
43	Observation delayed
44	Power failure
45	Unfavorable weather conditions
46	Low maximum altitude (less than 1500 feet above ground)
47	Leaking balloon

48	Ascent not authorized for this period
49	Alert
50	Ascent did not extend above 400 hPa level
51	Balloon forced down by icing conditions
53	Atmospheric interference
54	Local interference
55	Fading signal*
56	Weak signal*
57	Preventive maintenance
58	Observation equipment failure (transmitter, balloon, attachments, etc.)
59	Any reason not listed above

* Fading signals differ from weak signals in that "fading signals" are first received satisfactorily, then become increasingly weaker, and finally become too weak for reception, while "weak signals" are weak from the beginning of the ascent.

60 - 64:	Miscellaneous
62	Radiosonde report precedes
64	Stability index follows: 000I _s I _s
65 - 69:	Doubtful Data
65	Geopotential and temperature data are doubtful between following levels: 0P _n P _n P' _n P' _n
66	Geopotential data are doubtful between the following levels: 0P _n P _n P' _n P' _n
67	Temperature data are doubtful between the following levels: 0P _n P _n P' _n P' _n
68	Dew point depression is missing between the following levels: 0P _n P _n P' _n P' _n (not used when T _n T _n is also missing)
70 - 74	Not allocated

Breakdown for 101A_{df}A_{df} - Miscellaneous Regional Data (Continued)

75 - 89	Corrected Data
78	Corrected tropopause data section follows
79	Corrected maximum wind section follows
80	Corrected report for the entire report (<i>first*</i> and <i>second*</i> transmissions) follows
81	Corrected report of the entire PART A and/or PART B precedes

- 82 Corrected report of the entire PART C and/or PART D precedes
 - 83 Corrected data for *mandatory levels*** follow
 - 84 Corrected data for *significant levels*** follow
 - 85 Minor error(s) in this report; correction follows
 - 86 *Significant level(s)* not included in original report follow:
//P_nP_nP_n T_nT_nT_{an}D_nD_n or P_nP_nP_nT_nT_n
 - 87 Corrected data for *surface* follow
 - 88 Corrected *additional data* groups follow: 101A_{df}A_{df} etc.
- 90 - 99
- 90 Extrapolated geopotential data follow: P_nP_nh_nh_nh_n (d_nd_nd_nf_nf_n)
 - 94 Averaged wind for the surface to 5000 foot Mean Sea Level (MSL) layer and the 5000 to 10000 foot MSL layer follows: dfff dfff (can be used in the PART A message)

Note: Numbers not shown have no assigned meaning or do not pertain to NWS upper-air sites.

Unless both the stability index and the mean winds are missing, the Part A message always contains two special 101 groups as follows:

10164 Group that identifies stability index.

10194 Group that identifies the mean winds.

A 5-character group 000I_sI_s follows the 10164 which contains the encoded stability index. The I_sI_s value that appears in the coded message for the stability index is interpreted as follows:

<u>Code Value</u>	Stability Index Table <u>Meaning</u>
00 to 40	Stability index is 0 to 40
51 to 90	Stability index is -1 to -40
91	RH < 20% at either base or 500 mb level or calculation failed.
92	RH is missing at the base level.

The 10194 group for mean winds from the surface to 5000 feet MSL and from 5000 to 10000 feet MSL are encoded in two code groups using the format d_md_mf_mf_mf_m, where d_md_m is the mean direction and f_mf_mf_m is the mean wind speed. If the mean wind is missing, it is reported as /////. If winds for both layers (i.e. Sfc. - 5K and 5K to 10K feet MSL) are missing, the 10194 is not sent.

Additional 101 groups as shown in the Table can be entered after the 51515 as long as the last two digits are in ascending order with the other groups. For example, if the report has been corrected, this section would appear as follows:

51515 10164 00092 10181 10194 ///// 26516=

APPENDIX G - TERMINATING and ARCHIVING the OBSERVATION

<u>Table of Contents:</u>	<u>Page</u>
1. Introduction.....	G-1
2. Termination.....	G-1
2.1 Automatic Termination.....	G-2
2.2 Manual Termination	G-2
2.3 Termination of RRS Observations.....	G-3
3. Point of Observation Termination	G-4
4. Reason for Observation Termination.....	G-4
5. Termination at Predetermined Level	G-5
6. Data Archival	G-5
7. RRS Termination	G-5
8. RDF Shutdown Procedures.....	G-5
8.1 Standby - RDF System Components	G-5
8.2 Power-Down - RDF System Components	G-6
8.3 Procedures for Archival Using RRS.....	G-6

1. Introduction. This appendix explains observation termination procedures and data archiving. It is important to remember that these tasks should be completed after reviewing the data. The observer should review the point of termination, termination reason, and that all data is accurate and should be archived. The software can not select the correct reason for termination for every occasion. The observer should verify the accuracy of the observation data throughout the observation, prior to transmission and again prior to data archiving.

Note: RRS observers should follow instructions in Chapter13 of the RRS User Guide.

2. Termination. The most common reasons an observation is terminated are:
- a. **Balloon burst:** Nearly all observations terminate due to balloon burst. A plot of pressure versus time will show a change to increasing atmospheric pressure values. The system detects this and initiates an automatic termination.
 - b. **Floating balloon:** The system can detect the signal trend characteristics of a floating balloon (i.e., nearly constant altitude). The software will usually

terminate the observation.

- c. **Excessive Missing Data:** Missing data results when radiosonde signals become weak or fade in and out. If this continues beyond set limits the system will terminate the observation.

2.1 Automatic Termination. When the observation is automatically terminated, the observer looks at the data to decide if the reason for termination and point of termination selected are correct.

The observer should always go into the “MET” and “POSITION” data and look to see that the observation was terminated at the right point. One should look for:

- a. Realistic ascension rates – Ascent rates faster than 500 meters/minute typically indicate a problem with the pressure sensor. Check the heights in the “MET” data and compare the heights at different times and divide the height difference by the minutes between the heights selected.
- b. Realistic “Pressure vs. Time” plot - There should be no abrupt changes in the pressure profile prior to termination. If a failed or leaking pressure cell is detected by a flattening out of the plot or if there is an abrupt jump in the plot terminate the observation at the point where the profile shows erroneous data.
- c. No duplicate levels at or near the termination point - The observer should type “LE” and check the last level and the level preceding it to ensure there is at least 0.1 hPa difference in the values. If there is a duplicate level, the last level will be deleted by hitting the “F8” key.

Note: MicroART does have a status check message for “Duplicate Pressure Levels” and if displayed, the observer will go into the Levels table and delete the last level selected.

The observer can then edit and transmit the coded messages, as discussed in Chapter 9 and 10 of the MicroART Training Guide.

After transmitting the coded messages, exit the “ART Observation” option following procedures described in Chapter 11 of the MicroART Training Guide.

2.2 Manual Termination. An observation may reach a point where it should be terminated because of erroneous data, but MicroART has not terminated the observation. In such cases, the observation will be terminated manually. The following step should be performed to manually terminate an observation:

At the> prompt, TERM should be typed and strike the (enter) key.

2.3 Termination of RRS Observations.

- a. Automatic termination by system - RRS terminates an observation automatically when the data indicates the observation should be ended. When the observation is terminated the Check, Status, and coded messages appear on the screen. The coded messages may be edited and transmitted. It is important to check the data for correctness before transmitting any coded messages.

Automatic termination can occur for a number of reasons, but the three most common are balloon burst, floating balloon, weak or fading signal. The observation will also automatically terminate if 3 consecutive minutes of missing temperature data occurs. The UPS Status Window will appear indicating the software has terminated the observation. The observer should click the “OK” button to turn OFF the UPS and power to TRS.

The types of automatic termination are:

- (1) Balloon Burst- Most observations terminate due to balloon burst. The pressure profile is the best indication that the observation has terminated for this reason.
- (2) Floating Balloon- Occasionally an observation terminates because the balloon stops rising and begins floating at a nearly constant altitude, or rises so slowly that there is no point in continuing the observation.
- (3) Weak or Fading Signal- If the radiosonde signal becomes weak the data quality will usually drop off, resulting in missing data. If this continues for too long, the observation is terminated automatically.

- b. Manual termination by observer- An observation may reach a point where it should be terminated, but RRS has not terminated the observation. In such cases the observation should be terminated manually. The following steps should be performed to manually terminate an observation:

- (1) Click on the Flight Option. Select “Terminate”. The validation window will appear. Click “Yes”.
- (2) After clicking “Yes” in the “Validation” window, the Check, Status, and WMO Coded Message windows are generated. On top of these windows, the “UPS Power” window appears. If you click “Yes” the power to the TRS and SPS is shut down.

NOTE: Turning off the UPS enables the proper shutdown of the TRS and tracking equipment.

- (3) After clicking “Yes” in the UPS Power window. A “Validation” window

appears. Click “Yes” to confirm that you wish to shutdown the UPS.

- (4) The window appears to be alerting you that the UPS status has been turned off. Click “OK” to proceed.
- (5) The window will appear. Click “OK”.
- (6) Ensure prior to transmission that the Termination Point is correct by looking at the Processed Data Set and marking or deleting data if necessary. Transmit the coded messages that have not been transmitted.
- (7) After transmitting the messages, open the Flight Summary display and copy or print the data required in WS Form B-29. If a problem or abnormal condition occurred, save and print the messages or plots that apply. Go to the top of the RWS main window and under the Flight option select “Close”.

c. Predetermined termination at a certain pressure level- A special (a-synoptic) observation can be determined when it reaches a predetermined pressure level. This pressure level is entered on the Administrative Data screen. The observation has to reach a minimum of 400 hPa prior to automatic termination.

d. Sudden unexpected failure such as hardware or power failure.

3. Point of Observation Termination. Validation that the proper point of termination has been selected is made. This involves following the procedures as indicated in section 2.1.

4. Reason for Observation Termination. MicroART and RRS provide the following reasons for observation termination:

a. MicroART

- (1) Balloon burst
- (2) Balloon forced down by icing
- (3) Leaking or floating balloon
- (4) Weak or fading signal
- (5) Battery failure
- (6) Ground equipment failure
- (7) Interference
- (8) Radiosonde failure
- (9) Excessive missing data
- (10) Other

b. RRS

- (1) Balloon burst

- (2) Balloon forced down by icing
- (3) Leaking or floating balloon
- (4) Weak or fading signal
- (5) Battery failure
- (6) SPS failure
- (7) Signal interference
- (8) Radiosonde failure
- (9) Excessive missing data
- (10) Excessive missing temperature data
- (11) Excessive missing pressure data
- (12) User selected to terminate
- (13) RWS software failure
- (14) TRS failure
- (15) MUX failure
- (16) RWS unknown failure – Recovery
- (17) Unknown/Other

When an upper-air observation is terminated, one reason from the list is selected and entered into MicroART.

5. Termination at Predetermined Level. If required, a special observation can be terminated when it reaches a predetermined pressure level. This pressure level is entered on MicroART's Administrative Data screen. Termination procedures for this type of observation are identical to those for the automatic termination method in Section 2.1.

6. Data Archival. Data should be archived at the end of each observation. Observations with problems should have the "Log" and "Store" diskettes saved and set aside for further evaluation. If the data is to be sent to the Regional Upper-Air Program Manager or the NWS Upper-Air Program Office for further evaluation, emailing a copy of the calibration data file and a statement of what happened with pertinent plots to help illustrate the problem will be helpful.

To archive the data: Follow the instructions in Chapter 12 of the MicroART Training Guide. Send the Archive and Store Files to NCDC using File Transfer Protocol (FTP). Do not send the data to NCDC on diskettes, CD's, etc.

7. RRS Termination. For complete termination procedures see RRS User Manual Chapter 9.

8. RDF Shutdown Procedures. When the observation has terminated, the "STOP PRINT" switch on the Master Control Unit is pressed for at least one minute. This will stop the timer that records the observation duration since the release switch was pressed to begin the observation.

8.1 Standby - RDF System Components. Placing the equipment in standby, in anticipation of another observation, eliminates the necessity of equipment warm-up and performing all operational checks. To place the equipment in standby the observer does the following at the Master Control Unit:

- a. Turn the target antenna on.
- b. Aim the reflector at the target antenna and with the motors in “Near Auto” to allow the antenna to lock on the target antenna.
- c. The antenna should read within ± 0.05 degrees in both elevation and azimuth of the surveyed points for the target antenna. If it is not within tolerance, another attempt to lock-on the target antenna should be performed. If this fails, an EMRS report will be completed and the electronics technician notified.
- d. Press the STANDBY button.
- e. Leave the MicroART computer on.

8.2 Power Down - RDF System Components. To power down equipment: The following should be accomplished at the Master Control Unit (MCU):

- a. Instructions in section 8.1 should be followed ignoring item e. “POWER” switch on MCU should be set to OFF.
- b. After the observation has been archived, the operator should at the MicroART Main Menu select “Shut Down System”. Turn off the printer and the IBM XT at the power source.

8.3 Procedures for Archival Using RRS.

- a. After selecting “Close” a “Validation” window appears. Click “Yes”.
- b. A final window appears stating that the observation was saved to the database. Click “OK”.
- c. Under the “Tools” at the top of the RWS Main window select the Utilities option.
- d. Under the “RWS Software Utilities” select the “NCDC Archive Utility”. Notice the first line of the Ascension Table is grayed out. This is an observation from another site. It can not be archived.
- e. In the NCDC Archive Utility Display a list of ascension numbers shows which observations have and have not been archived. Observers archive the data after each observation to ensure data is not lost due to system or equipment outages.
- f. After selecting the observation you wish to archive, by clicking on the far left column, and then clicking on the “Archive” button, a window appears allowing you to designate a subdirectory to store the file. The default subdirectory is C:\RWS\RWS\NCDC. You may also insert a CD into the “D” drive and then

select the “D” drive to copy the Archive data by pressing “OK”.

NOTE: Placing the data on a CD provides additional security of the observation data should a hardware failure occur. The Archive data will be Zipped and sent by FTP to NCDC from the RRS workstation using instructions in Chapter 10 of the RRS Users Guide.

- g. Verify the observation was archived by going back and viewing the Archive Table. The block in the “Archive” column should have a “Yes” entered.
- h. After archiving the observation, go back to the Flight option window and select “Exit”. This will shut the RWS software down.

Note: Maintain at least a 3 month archive of data on CDs or back-up hard drive.

APPENDIX H - QUALITY CONTROL of DATA

<u>Table of Contents:</u>	<u>Page</u>
1. Introduction.....	H-1
2. Upper-Air Station Observer.....	H-1
2.1 Contacting the SDM	H-2
3. National Centers for Environmental Prediction (NCEP).....	H-2
4. National Climatic Data Center (NCDC).....	H-3
5. Regional Headquarters.....	H-3
6. Weather Service Headquarters.....	H-3

1. Introduction. Although upper-air observers are required to quality control their observations prior to dissemination, not all data errors or problems can be identified, corrected, or deleted. Effective data quality control is a multi tiered process involving the upper-air observer, NCEP, NCDC, and administrative offices at the regional and national level. This Appendix provides an overview of how upper-air observations are quality controlled.

2. Upper-Air Station Observer. Each observer quality controls their observations prior to dissemination. Do not assume someone else will detect and correct the errors. Chapters 9 and 14 of the MicroART Training Guide and Chapter 5 and 11 of the RRS Training Guide provide instructions and procedures for handling questionable and erroneous data. There will be situations (e.g., severe weather outbreak) where the workload will preclude the checking the validity of the observation data prior to transmission. If such a situation occurs, transmit the data and archive it accordingly. However, at a later date check the validity of the archive data, edit as appropriate, and resend to NCDC as a correction. Chapter 5 of the MicroART Training Guide and Chapter 4 of the RRS Training Guide provide instructions on reworking an observation.

The observer and the station manager should review all quality control reports received from NCEP, NCDC, Regional Headquarters, and WSH. These reports, as well as the station’s WS Form B-29 information helps identify data errors and equipment problems.

Providing the highest quality upper air observations is essential for NWS forecasts and warnings. Sites will follow prescribed operating procedures shown in this manual and the appropriate Training Guide. All observers should be familiar with the Training Guides and understand that Regional and WSH personnel monitor observation data from sites as does NCEP and NCDC. Disregard of proper procedures and policies will result in a degradation of the site’s performance and will be reflected in statistics compiled for evaluating the network and site performance.

2.1 Contacting the SDM. Observers will quality control the sounding data as best as possible and then transmit it. There may be cases where the observer is not sure about the data quality even after edits are made and the raob is transmitted. In such cases, the observer should contact the NCEP Senior Duty Meteorologist (SDM), and note that edits were made to the transmitted sounding data, but there may still be some data problems. **Never transmit clearly erroneous soundings and expect the SDM to quality control the data. NWS soundings are used worldwide and the SDM only handles soundings used for NWS models.**

3. National Centers for Environmental Prediction (NCEP). Before inputting radiosonde data into numerical weather prediction models, NCEP corrects Lockheed Martin Sippican B2 temperature data for solar and infra-red radiation and checks the quality of the data using objective and subjective techniques.

Solar and infra-red radiation typically affects the Lockheed Martin Sippican temperature data at pressures less than 100 hPa (see appendix A section 3.2.3). The temperature errors caused by this radiation can exceed 1°C. Since the observers do not have the tools to determine the extent of the temperature errors caused by radiation, they are not to correct the data.

The RRS software uses the cloud group and other factors to adjust a solar radiation temperature correction or algorithm to more accurately reflect the temperature. Thus, entering accurate cloud and weather data is necessary to ensure the method applied is accurate.

NCEP data quality checking utilizes a computerized comparison of the actual upper-air data received from an upper-air station with that generated from a “first guess” numerical weather prediction model. If the temperature, geopotential height, RH and/or wind data compare poorly, the upper-air data are either deleted, corrected, or remain as is. Typically, most data deletions are for temperature and height data at pressures less than 100 hPa.

Upper-air charts are also examined to help find bad data. New tools have been developed and RH data are as vigorously checked as wind and temperature data. Lastly, NCEP’s quality control methods are not perfect and errors do pass through undetected. Thus it is very important that the observer checks the validity of the observation data before it is disseminated.

Observers can review a summary of the NCEP upper-air data quality control by reading the “Special NCEP Discussion” obtainable on Advance Weather Interactive Processing System (AWIPS). These messages include a log prepared by the SDM on observations they detected had data problems, were late or missing, and other information related to NCEP operations. Information on NCEP upper-air data quality control is issued daily at about 02:00 and 04:00 UTC and 1400 and 1600 UTC. The first message at 02/14Z is to inform the field of the NAM start and what stations were in for the NAM ingest, (1315Z and 0115Z). The second message, (at or about 04Z/16Z) is the status of the current cycle, including any new stations (in the NAM domain) that were available for the GFS data ingest (1546Z/0346Z).

Note: The SDM log does not always include observation data rejected by the computerized automated Quality Control (QC) system. The SDM may over-rule the autoqc recommendations to inform the field that although the data may look erratic the meteorology agrees that the

observation is a true representation of the atmosphere. Observers need to review other NCEP reports to obtain a complete picture of their observation data quality.

Observers should not be alarmed if, on occasion, all or a portion of their observation is flagged as having bad data. Although the observation data may pass all the MicroART data checks, NCEP has different tools for assessing data quality not available at the upper-air site. However, if it is noticed that station observations are often flagged with bad data, there may be a problem with the ground equipment, radiosondes, or incorrect observational procedures. NCEP also issues monthly summaries of observation data quality.

4. National Climatic Data Center (NCDC). Similar to NCEP, NCDC relies on a mix of objective and subjective procedures to quality control the upper-air data before it is archived. NCDC checks RH data quality (primarily for rapid, unrealistic fluctuations in RH). Each observation undergoes a series of checks to determine the plausibility of all available data. If data is determined to be suspect or clearly erroneous, it is flagged as such, but is not deleted from the archive.

Each month NCDC prepares “Upper Air Quality Assurance Reports” for each upper-air station as well as Regional and National summaries. The report lists all the data flagged during the month.

Don’t be too concerned if NCDC finds errors the observers did not detect. NCDC applies quality control techniques not available to the field sites. However, NCDC’s data quality assurance program does not detect all errors. This is why special care is taken to ensure that the observations are checked for errors prior to being sent to NCDC. If NCDC finds frequent problems with observations from a site, the station staff and Regional Headquarters should work together to determine if station equipment or operational procedures are the cause.

5. Regional Headquarters. The Regional Upper-air Program Manager at a minimum prepares and issues a quarterly report summarizing upper-air station performance for the stations in their region. Data for this report comes from the various upper-air forms (e.g., the WS Form B-29) the stations fill out each month, as well as data quality reports prepared by WSH. This report provides useful performance information (e.g., average burst altitudes) not found in the NCEP or NCDC reports. This report should be available for site review. If a site is performing poorly compared to other stations, the site and the Regional Office need to discuss the problems and determine possible solutions.

6. Weather Service Headquarters. WSH analyzes daily observations, as well as data quality reports and correspondence from NCEP, NCDC, and the Regional Offices. Stations with serious or ongoing data problems are identified. WSH coordinates its findings with Regional Offices and provides possible causes for the problems and recommended solutions.

**APPENDIX I - COMPLETION OF DOCUMENTATION
(FORMS)**

<u>Table of Contents:</u>	<u>Page</u>
1. Introduction.....	I-1
2. Forms Required to be on Station	I-1
3. Completion and Submission of Forms.....	I-2
3.1 WS Form B-29 Rawinsonde Report	I-2
3.2 WS Form B-48 Upper Air Program Review Guide.....	I-5
3.3 WS Form B-85 Rawinsonde Inventory.....	I-6
3.4 WS Form H-6 Report of Defective Radiosondes and Batteries	I-8
3.5 WS Form A-22 Special Upper-Air Observation Report.....	I-9
3.6 WS Form H-14 Equipment Return Tag	I-10
3.7 WS Form B-17 Rawin-Theodolite Comparison	I-12

1. Introduction. Keeping records of upper-air observation performance, equipment, and logistics is a key component of the upper-air program. This information is used to determine if the station is operated and maintained in accordance with established procedures and to help manage upper air supplies. A number of forms are used to collect this information and this appendix provides information on their completion and submission.

It is essential that all upper-air forms are completed with accurate information and submitted in a timely manner. Updates to a form submitted months ago has little value for NWS operations. All forms should be completed accurately within 3 days after the end of the month.

2. Forms Required to be on Station. The following forms are required at each site either in an electronic format or as a hard copy.

WS Form A-22	Special Upper-Air Observation Report
WS Form B-17	Rawin-Theodolite Comparison (Not Required for RRS sites)
WS Form B-29	Rawinsonde Report
WS Form B-33	Station Inspection Report
WS Form B-48	Upper-Air Program Review Guide
WS Form 10-13-1	Certificate of Authority to take Weather Observations
WS Form B-79	Data Sheet for Balloon Tests (Balloon test sites only)
WS Form B-85	Rawinsonde Inventory
WS Form H-6	Report of Defective Radiosondes
WS Form H-14	Equipment Return Tag

3. Completion and Submission of Forms. Currently there are three upper air forms, WS Form B-29, WS Form B-85, and WS Form H-6 that are submitted directly to the MIRS website. (<http://www.weather.gov/mirs/>) Station staff should consult their Regional Office Upper-Air Program Manager for the latest URL to this website and to request user accounts for new observers so that they can get access to the forms.

WS Forms A-22, H-14 and B-17 are completed using Word or other approved software and sent via email or regular mail to appropriate NWS staff as directed.

Note: All upper air forms will be retained on station until the Weather Forecast Office (WFO) is closed, or when networks are replaced by newer equipment or facilities. Transfer to facility that assumes responsibility.

3.1 WS Form B-29, Rawinsonde Report. WS Form B-29 is accessed via the MIRS website and is submitted each month. Begin this form with the scheduled 0000 UTC observation on the first day of the month. Observation information should be logged into the form after each observation. **The completed monthly form is submitted within 3 days after the end of the month.**

Caribbean upper-air stations funded by WSH should also submit the form using the NWS website. If they can not access the website they should prepare three copies of WS Form B-29. One copy should be sent to the WSH Upper-Air Program Office, and WSH Maintenance Logistics and Facilities Branch.

Entries on WS Form B-29 should be made as follows:

- a. Station Information- The station name and the four letter Station Identification Number (SID), the name of the person preparing the form, the form date, number of observations, and the observation ascension numbers are automatically filled in. This information should be checked for accuracy and WSH notified if errors are found.
- b. Observation Equipment-
 - (1) Rawin - Rabal Comparison - Latest Route Mean Square (RMS) - Enter the RMS and date of the last comparative.
 - (2) Date of Last Alignment - Select the date of the last receiver and tracking alignment check by the site electronic technician.
 - (3) Orientation Check - Entry should be "Daily". If this check is not completed before each observation, indicate the reason why in the "Remarks" block.
 - (4) Total Number of Observations with Limiting Angles - Enter the total number of observations where the limiting angle condition (i.e., no winds

were calculated for a period of time) occurred.

- (5) Theodolite General Test - This test is performed quarterly. Enter the elevation (EL) difference, azimuth (AZ) difference, and data of latest test. Maximum allowable tolerance is $\pm .2$ degrees.
- (6) Rejected Balloons - Enter the balloon manufacturer, lot number or date of manufacture, and select the reason for rejection. Include in the remarks section balloon type, size, and type of defect for each balloon rejected during the period of the report.

Note: Upper-air stations using the Radiosonde Replacement System (RRS) or Loran tracking systems do not need to make entries for items 1 through 5.

- c. Unsuccessful Releases- Make entries for **all radiosondes** released that did not reach 400 hPa. This includes observations not assigned an ascension number. Whenever entries are made for an unsuccessful release and the cause of the early termination is known, document the problems encountered during the observation. As an example, if battery problems were suspected, be sure that all information on the battery is listed.
- d. Second and Third Releases - Enter the observation date, flight time, and if the release is a second or third. Include in the remarks the reason for taking the extra release.
- e. Missed and Special Observations:
 - (1) Missed Observations - Enter the date, time, and reason when a scheduled observation is not taken. In the remarks section provide additional information on the missed observation and corrective actions made.

A missed observation is defined as a 00z or 12z observation where no upper-air data aloft was available for transmission to NCEP and NCDC. This would occur when the ground equipment is broken and no radiosonde can be released, or, when a release occurred but no data was received or all data was considered erroneous and no second release was authorized.

If good data is obtained from a radiosonde that failed to reach 400 mb, and no other sounding was authorized, then this sounding is given an ascension number and the data transmitted to NCEP and NCDC.

- (2) Special Observations - Enter the date, time of release, and the reason for taking a special. In the remarks section, note who requested the special observation, (e.g., Project Cosmos, National Hurricane Center, Lead Forecaster).

Note: Enter only special observations that have been assigned an ascension number and sent to NCDC for archival. Also, enter all specials taken in the Flight Summary Information Section.

- f. Station Operation and Equipment Remarks: All other pertinent remarks not included in other sections of the form should be included in this block. Mandatory remarks include:
- (1) Effective date and time of changes in the upper-air program. This includes instructional changes, change in the type of radiosondes used or the number of routine observations per day, installation of new upper-air equipment, and equipment modifications.
 - (2) Ground equipment problems encountered and corrective actions taken. When a system or a component of a system has been inoperative during the period covered by the report, enter the name of the system or component and dates out of service and back in service.
 - (3) Corrections to entries on preceding WS Form B-29's. A brief, but complete explanation should be included.
 - (4) Continuation of remarks from the remarks section in the Observation Summary section of the form.
 - (5) If wind data were lost due to limiting angles, include the height boundaries of the limiting angles for each observation. This may also be logged in the remarks section of the Flight Summary.
- g. Flight Summary Information: Make entries in the Flight Summary for each observation that is assigned an ascension number. Observations taken for test purposes or comparatives would be logged in the Special releases and a note made in the "Remarks" column. Make entries as follows:
- (1) Ascension Number (ASCNO) - List each observation that has been assigned an ascension number.
 - (2) Date (UTC) - Select the month and day of the observation.
 - (3) Observation (OBS) Time (UTC) - Enter the observation time to the nearest whole hour, UTC; (e.g., "12" would be entered for the 1200 UTC observation.
 - (4) Radiosonde Serial Number - Enter the complete radiosonde serial number. This includes letter designations that are a part of the radiosonde serial number.
 - (5) Sonde Type - Select the radiosonde type.

RDF = Radio Direction Finding (MicroART)

LRN = LORAN

GPS = Global Positioning System

- (6) Balloon Manufacturer - Select the appropriate balloon manufacturer.
- (7) Lot Number or Date of Manufacture - Enter the balloon lot number. If not available, enter the date of balloon manufacture printed on the balloon bag or shipping box.
- (8) Nozzle Lift - Enter the value to the nearest 100 grams or cubic foot.
- (9) Balloon Ascent Rate - Enter the ascent rate of the balloon from the surface to the 400 hPa level and from the 400 hPa level to observation termination. Enter the values to the nearest meter.
- (10) RAOB Termination - Select the reason for termination.
- (11) Height - Enter the termination height of the observation to the nearest meter.
- (12) Remarks - Enter remarks concerning anything unusual about the observation. If additional space is needed, the remarks should be continued in the Station Operation and Equipment Remarks section.
- (13) Observer - Enter the initials of the observer who took the observation.

3.2 WS Form B-48, Upper Air Program Review Guide. This checklist is an excellent tool to evaluate a site's upper-air program. The WS Form B-48 serves a dual purpose. It allows the site to do a self-inspection of their upper-air operations and correct deficiencies. The inspection checklist is also used by national and regional personnel when visiting an upper-air site to ensure the site is following established procedures and guidelines. The form has been designed to promote uniformity in the site inspection procedures to ensure each site knows what is expected and what areas should and will be checked routinely. After completion, a copy should be emailed to WSH.

Completion of WS Form B-48:

- a. Each site should use the checklist to perform a self-inspection once every 12 months. Deficiencies should be corrected immediately.
- b. Regional personnel should visit each upper-air site at least once every 2 years and use the form in conjunction with the WS Form B-33 to assess the station's overall performance.

3.3 WS Form B-85, Rawinsonde Inventory. WS Form B-85 is accessed via the MIRS

website and should be completed promptly at the end of each month. Check all entries for accuracy and **submit the form within 3 days after the end of the month.**

Caribbean upper-air stations funded by WSH should also submit WS Form B-85 using the NWS website. If the web site can not be accessed, then prepare three copies of the form. One copy should be sent to the WSH Upper-Air Program Office, and WSH Maintenance Logistics and Facilities Branch. The final copy should be kept on station until closed or when networks are replaced by newer equipment or facilities. Transfer to new facility that assumes responsibility.

Entries on WS Form B-85 will be completed as follows:

- a. Station Information: The station name and the four letter station identification (SID), the name of the person preparing the form, and the date are automatically filled in. This information should be checked for accuracy and WSH notified if errors are found.
- b. Monthly Inventory - Part I: Columns identified as "Radiosondes and Balloons" are divided into sub-columns. This is for the sites having more than one type of radiosonde or balloon type on station. In such instances, separate inventories for each type of radiosonde or balloon are required.

Make the following entries:

- | | |
|---------|---|
| Line 1. | Beginning Balance - Enter the total number of radiosondes and balloons at the start of the month. |
| Line 2. | Quantity Received During Month - Enter the number of radiosondes and balloons received during the month. |
| Line 3. | Total Available During Month - The total of line 1 and line 2. |
| Line 4. | Released During Month - Total number of radiosondes and balloons released in the month. This includes the number used for additional releases and comparisons. |
| Line 5. | Quantity of Serviceable Items Shipped - Indicate the number of serviceable radiosondes or balloons shipped during the month. Indicate in "Remarks" the site to which they were shipped. |
| Line 6. | Rejected Number of Items - Number of radiosondes and balloons rejected for whatever reason. |
| Line 7. | Total Used - Total number of radiosondes and balloons used during the month. This is the sum of line 4, line 5, and line 6. |
| Line 8. | Ending Balance - Number of serviceable radiosondes and balloons |

on hand at the end of the month. This is the difference from line 3 and line 7. Do not include rejected items.

- Line 9. Ending Balance - Number of serviceable radiosondes and balloons on hand at the end of the month by actual count. **Do not leave this entry blank.**
 - Line 10. Defective Items on Hand - The number of defective radiosondes and balloons on hand at the end of the month.
 - Line 11. Quantity of Defective Items Shipped - Total number of defective radiosondes and balloons shipped during the month to the National Reconditioning Center (NRC). Contact WSH for instructions on where to ship defective balloons.
 - Line 12. Surplus Hygristors on Hand - Quantity of usable spare hygristors on hand at the end of the month.
 - Line 13. Surplus Batteries on Hand - Quantity of usable spare batteries on hand at the end of the month.
 - Line 14. Shipment Number - Enter the shipment number taken from the outside of the radiosonde or balloon box.
- c. Supplemental Inventory and Remarks - Part II - Take an end of the month inventory of all upper-air expendables and fill in the appropriate form entries. This includes the count of individual cylinders of lifting gas, lighting units, train regulators or dereelers, parachutes, and rolls of twine. **Do not enter the quantity of boxes or cases in stock.**
- d. Flight Summary:
- (1) Number of 2nd Releases - Enter the total number of second balloon releases during the month.
 - (2) Number of 3rd Releases - Enter the total number of third releases during the month.
 - (3) Number of Special Releases - Enter the number of special releases for whatever reason.
 - (4) Number of Unsuccessful releases and observations - Enter the total number of releases that did not reach 400 hPa. **Note:** This number has to be equal to or greater than the total number of 2nd and 3rd releases.
- e. Remarks - include information about supplies. This includes items missing from a

shipment, excessive number of batteries rejected, damage to shipments, and the balloon and radiosonde type if listed as “other”. Use this space as a continuation sheet for Part I whenever necessary.

3.4 WS Form H-6, Report of Defective Radiosondes and Batteries. WS Form H-6 is accessed via the MIRS website and should be filled in and submitted as radiosondes and batteries are rejected. At a minimum, the form is completed and submitted within 3 days after the end of each quarter. When shipping a box of rejected Radiosondes to NRC, a hard copy of the H-6 form should be enclosed within each box of the shipment.

Caribbean upper-air stations funded by WSH should also submit WS Form H-6 using approved procedures. Prepare three copies of the form. One copy should be sent to the WSH Upper-Air Program Office, and WSH Maintenance Logistics and Facilities Branch. The final copy should be kept on station until the station is closed or when networks replaced by newer equipment or facilities. Transfer to new facility that assumes responsibility.

Note: Rejected Batteries will not be shipped to NRC. Contact WSH for information on where they should be shipped.

Entries on WS Form H-6 will be completed as follows:

- a. Station Information - The station name and the four letter station identification (SID), the name of the person preparing the form, and the form period are automatically filled in. This information should be checked for accuracy and WSH notified if errors are found.
- b. Radiosonde Serial Number - Enter the complete radiosonde serial number for each instrument or battery rejected. This includes letter designations that are a part of the radiosonde serial number.
- c. Date on Sonde - Select the date the radiosonde was manufactured. This is typically stamped on the outside of the radiosonde. If there is no stamped date, check the shipping information sheet or calibration diskette for the date.

Note: Vaisala radiosondes have the month and year printed on the radiosonde calibration diskette as “Manufacturing Date: yy-mm”.

Where "yy" is the year and "mm" is the month. Example: 04-05 means May, 2004.

If the day of the month is missing on the cal diskette, use "15" in the H-6 form entry. Example: 05/15/04.

- d. Date Rejected - Select the date the radiosonde or battery was rejected.
- e. Reason for Rejection - Select the reason for rejecting the radiosonde or battery.

- f. Specific Information on why the radiosonde (or battery) was rejected. Provide a description of the defect, if known. If unknown, describe the performance which resulted in the rejection.
- (1) If you open the sonde and the battery is broken (e.g., crushed, missing wire) it would be best to simply reject the entire instrument for warranty return to NRC. Include the damaged battery with the shipment.
 - (2) If you open the sonde and the instrument is damaged (crushed packaging, broken temperature sensor, missing parts, etc) reject the instrument and save the battery as a spare. Please do not send unopened batteries back to NRC unless authorized by WSH.
 - (3) If the sonde fails baseline, but the battery works okay, use the battery in a new sonde and baseline again. Save the unopened battery you removed from the new sonde and keep it as a spare. Yes, the battery is operating longer than expected, but it will function quite well for more than 130 minutes.
 - (4) If your office has more than 12 spare batteries, please contact your Regional Office Upper air Program Manager who will find a site where you can send your surplus.

Note: A radiosonde being returned that was not defective, but is being sent back for reconditioning should be identified as such, (i.e., Instrument returned to office by the public).

- g. 1st Obs Inits and 2nd OBS Inits. Enter the initials of the two persons who determined the radiosonde or battery was defective. All rejected radiosondes and batteries should be rechecked by someone other than the person who initially rejected the radiosonde initially.

Note: Ship defective radiosondes by parcel post to NRC. Ship defective radiosondes every 90 days, at a minimum, to ensure the one year warranty does not lapse. Rejected batteries will not be sent to NRC. Contact WSH for information on where to ship.

3.5 WS Form A-22, Special Upper-Air Observation Report. WS Form A-22 is used to report special upper-air observations taken for agencies outside the NWS. This form is not required for special observations requested for “Operational Purposes”. However, observations requested for “Research Purposes” or for outside agencies should be entered on the form.

Submit the form at the end of each month when non-NWS special upper-air observations are taken. This form should be sent no later than 2 days after the end of the month. Submit a separate set of forms for each reimbursable special project. Prepare the form in triplicate and submit the original to the Regional Upper-Air Program Manager, a copy to the WSH Upper-Air Program Office, and keep a copy on file at the station until the station is closed or when networks are replaced by newer equipment or facilities. Transfer to new facility that assumes responsibility.

All reimbursable special observations are approved at both the regional and national headquarters. Personnel time, including overtime, used while taking special upper-air observations is submitted on the Time and Attendance reports. The maximum overtime allowed for an upper-air observation is 3 hours. Entries on the A-22 will show the date and time of the special observation, the project name, and the number of hours overtime worked for each special observation taken.

Entries on WS Form A-22 will be completed as follows:

- a. Station - Enter the station name and the four letter SID.
- b. Date – Date the form was prepared, usually near the end of the month or when the set of specials for the project are known to be completed.
- c. Total Number of Observations - Number of special project observations taken that month.
- d. To - Copies should be sent to the Regional Upper-Air Program Manager and to the NWS Upper-Air Program Office.
- e. Project Name - Code name of the special project as supplied by the NWS Upper-Air Program Office or the Region.
- f. Number of Radiosondes Used - Number of each type of radiosonde used during the month for the special project.
- g. Release Date and Time - Release date and time (UTC) for each special observation taken for the project. Include the number of hours overtime worked for each observation. Maximum allowed per observation is 3 hours.
- h. Prepared by Signature - The form is usually prepared and signed by the station manager or the Upper-Air Focal Point on site.

3.6 WS Form H-14 Equipment Return Tag. WS Form H-14, Equipment Return Tag, should be used to return defective balloons to the National Reconditioning Center. Each balloon found to be defective should have a tag tied to it and returned to NRC prior to its 1 year warranty expiration.

Stations will mail the original to the National Reconditioning Center in Kansas City and keep a copy of the WS Form H-14 on station until the station is closed or when networks are replaced by newer equipment or facilities. Transfer to new facility that assumes responsibility.

Send to: National Reconditioning Center
1520 E. Bannister Road
Kansas City, MO 64131-3009
Attn: W/OSO322KC

Entries on the WS Form H-14- Entries will adhere to the following format:

- Line 1. Station Call Letter Identifier - Enter the station's 4 letter SID.
- Line 2. Organization Code - Enter the station's organization code. Obtain the code from the station manager or the administrative assistant if unknown.
- Line 3. Task Number - Enter 8M1J10.
- Line 4. Failure Date - Enter the date the balloon failed or was found to be defective.
- Line 5. Item Name - Enter balloon type (e.g., Balloon HM30). This designator should be on the outside of the balloon box. It is also the designator used by NLSC.
- Line 6. NWS Stock Number - Enter the Agency Stock Number (ASN) used at NLSC.
- Line 7. Item Serial Number - Enter N/A (There is no serial number for individual balloons).
- Line 8. Chassis S/N - Enter N/A.
- Line 9. Primary Reason for Return - Enter an "X" as the appropriate reason or enter "Other" and explain in item #11.
- Line 10. EMRS Failure Report No. - Leave Blank (Does not apply).
- Line 11. Defective Component, Description of Malfunction or Reason for Return - Elaborate on the reason for return (i.e, "Balloon had pinholes").
- Line 12. Completed by and Telephone No. - Enter observer name and the office telephone number.

Note: Items 13 - 18 - Leave blank, (Items are for National Reconditioning Center).

3.7 WS Form B-17, Rawin-Theodolite Comparison. Unless there is a Regional Supplement stating otherwise, all sites using MicroART equipment should perform a quarterly optical comparison and enter the information on WS Form B-17, Rawin-Theodolite Comparison. This requirement is essential in determining if the equipment is operating to standards. Overtime is authorized to ensure this requirement is met.

The comparison will be used to calibrate the rawin equipment. It is of utmost importance that the rawin and theodolite readings be made accurately and double checked to ensure errors are

avoided. Copies of the WS Form B-17 or its equivalent should be mailed to the Regional Upper-Air Program Manager and kept on station until the stations is closed or when networks are replaced by newer equipment or facilities. Transfer to new facility that assumes responsibility.

Entries of the WS Form B-17- Entries will adhere to the following format:

- a. Station and Equipment Information:
 - (1) Station - Enter the station name and the four letter SID.
 - (2) Type of Rawin Equipment - Enter GMD (ART-1), WBRT (ART-2) as appropriate.
 - (3) Receiver - Enter receiver serial number. (Check with site el tech or look at earlier forms).
 - (4) Antenna Control - Enter antenna control's serial number. (Check with the site el tech or look at earlier forms).
 - (5) Pylon - Enter pylon's serial number. (Check with site el tech or look at earlier forms)
 - (6) Date and Time of Release (UTC) - Enter the release time in UTC.

- b. Angular Data Entries - Angular data entries will adhere to the following methods:
 - Column 2. Theodolite Azimuth Angles - Enter the azimuth angles to the nearest 0.1 degrees.
 - Column 3. Theodolite Minus Rawin - For each fifth minute of the observation, subtract algebraically the rawin azimuth angle from the corresponding theodolite angle and enter this difference, with the proper sign, in column 3 of the WS Form B-17. This difference should not exceed 0.5 degrees.
 - Column 4. Theodolite Elevation Angles - Read the elevation angles to the nearest 0.01 degrees.
 - Column 5. Theodolite Minus Rawin - Beginning with minute 11, subtract algebraically the rawin elevation angle from the corresponding theodolite angle and enter this difference, with the proper sign. Omit the subtraction whenever the rawin elevation angle is greater than 60 degrees or is within the limiting-angle zone. The difference between the rawin and theodolite elevation angles should not exceed 0.5 degrees.

Column 6. Min. By Min. Change in Col. 5 - Compute the minute-by-minute changes in the differences between the rawin and theodolite elevation angles (column 5) and enter the changes, with the proper sign. For example, the first entry between minutes 11 and 12 would be the remainder of minute 11 minus minute 12.

Column 7. Square of Column 6 Entries - Square the column 6 entries and enter.

c. Summary Information. Use the following examples:

- (1) Sum of Col. 7 - Obtain the sum of all entries in column 7 and enter the value on line a.
- (2) Line "a" Divided by No. Of Entries in Col. 7 - Divide the sum (line "a" by the number of entries in column 7). Enter the mean on line b.
- (3) Square Root of Line "b" (Root Mean Square Difference) - Obtain from the Table of Average Root Mean Squares what the value from line "b" should equate to and enter into item "c". (For example: If the value of line b is 0.0020, the entry for line c would be 0.045.)

d. Observer and El Tech's Information - Adhere to the following format:

- (1) Theodolite Observer - Enter the theodolite observer's name.
- (2) Computer - Enter the name of the person doing the computations.
- (3) El Tech's Initials - The electronics technician initials the WS Form B-17 and take appropriate action.
- (4) Date - Date the WS Form B-17 was reviewed by the electronics technician.
- (5) Action Required - Yes or No.

Note: Use the following procedures:

- a. RMS value is 0.050 or less: The electronics technician will examine the form to determine the need for maintenance, and initial the forms after which they will be forwarded to the Regional Upper-Air Program Manager with the current WS Form B-29. If the electronics technician is expected to be absent from the station for more than 7 days, the forms will be forwarded without his/her initials to the Regional Upper-Air Program Manager with the current WS Form B-29.
- b. RMS value is greater than 0.050: Hold the forms at the station until corrective

action is taken. After the action is completed, send the forms to the Regional Upper-Air Program Manager with the current WS Form B-29. Another comparative observation should be taken as soon as corrective action has eliminated the problems causing the excessive RMS values. This should be completed within 3 days of the corrective action. Also, a comparison will be taken following major component repair or replacement. The WS Form B-17 or its equivalent should be forwarded to the Regional Upper-Air Program Manager.

APPENDIX J - STATION MANAGEMENT

<u>Table of Contents:</u>	<u>Page</u>
1. Introduction.....	J-3
2. Required Documents to be on Station	J-3
3. Required Software to be on Station	J-3
4. Retention of WS Form B-48 and WS Form B-33.....	J-4
5. Equipment Operation	J-4
5.1 Using the Theodolite.....	J-4
5.2 Limiting Angle Zone.....	J-4
5.2.1 Accuracy of Data	J-4
5.2.2 Obtaining Limiting-Angle Data.....	J-4
5.2.3 Updating Site Limiting-Angle Information	J-5
5.2.4 Disposition of Limiting-Angle Information	J-5
5.3 General Theodolite Test.....	J-5
5.4 Optical Theodolite Comparisons	J-6
5.4.1 Purpose of Taking Optical Comparisons	J-6
5.4.2 Procedures for Taking an Optical Comparison.....	J-6
5.4.3 Reporting RMS Values and Corrective Action	J-7
5.4.4 Disposition of the WS Form B-17	J-8
6. Initial Certification of New Personnel.....	J-8
6.1 Request for Observer Examination.....	J-8
6.2 Examination Requirements.....	J-8
6.3 Recency of Experience	J-9
6.4 Lapsed Certificate	J-9
6.5 Canceled Certificate.....	J-9
6.6 Validation upon Transfer	J-9
6.7 Vision Requirements.....	J-10
6.8 Changes in Radiosonde Types.....	J-10
7. Ordering Upper-Air Supplies and Expendables	J-11
7.1 Handling of Surplus Flight Train Equipment	J-11
7.2 Rejected Radiosondes, Balloons, and Parachutes	J-12
8. Accurate Station Data Information.....	J-12

Tables

J-1 Pressure Correction for Difference in Baseline and Release Point Heights.....	J-12
---	------

1. Introduction. It is the site supervisor's overall responsibility to ensure all aspects of the station's operations run smoothly. This includes the upper-air program. Persons assigned to a site without an upper-air program, but required to inspect an upper-air site should have a good understanding of current upper-air practices and procedures. Station management of the upper-air program includes the following:

- a. Adhering to current upper air policy and procedures.
- b. Training and certification of personnel.
- c. Data quality and timely dissemination of products and information.
- d. Safety of personnel and care of equipment.
- e. Ordering supplies and expendables.
- f. Ensuring accurate station data information.

2. Required Documents to be on Station. The following documents and reference manuals will be at each upper-air site.

- a. FMH-3 dated May 1997.
- b. MicroART Training Guide dated February 1999 or latest version of RRS User Guide.
- c. NWSM 10-1401, Rawinsonde Observations.
- d. Station Duty Manual.

WSH will be responsible for providing updated instructions as warranted. If the instructions are in error or require updating, notify your Regional Upper-Air Program Manager. If the regional office determines that your suggested change is valid, it will be forwarded to WSH for review and possible inclusion in future updates.

Note: A station that is nominated for the National Cline Award should have had a Regional visit within the period the nomination covers.

3. Required software to be on Station. The upper air office will keep a copy of the latest version of software on station at all times. The current software version of MicroART is 2.97 and 1.2 for RRS.

Only WSH authorized software is allowed to be loaded into the upper air PC. Unauthorized programs can overload the PC and stop it from working correctly.

4. Retention of WS Form B-48 and WS Form B-33. Sites performing a self-inspection

should retain a copy of the WS Form B-48 3 years after the inspection has been superseded by another inspection. Station assistance visits performed by NWS Headquarters or station inspections performed by regional personnel should provide a copy of the WS Form B-48 to station management prior to leaving the station. A meeting and discussion of the issues should be completed to ensure the site personnel have a clear understanding of the issues and areas that require attention. The WS Form B-33 will be retained on site until the station closes or when networks are replaced by newer equipment or facilities. Transfer to new facility that assumes responsibility. Instructions for WS Form B-33 are in NWSI 10-1303.

5. Equipment Operation. It is the responsibility of the site supervisor to ensure that the equipment is operating properly. This involves keeping the electronics staff notified of equipment problems and properly documenting deficiencies or outages into EMRS. Each observer should check the equipment prior to and during each upper-air observation. If an equipment problem affects the performance of the observation or causes a loss of data an EMRS report will be completed.

Besides the notification of equipment problems, an inspection of the inflation building is important to maintain safety at the site. This, and checking the accuracy of the equipment, is required to run a successful upper air operation.

5.1 Using the Theodolite. The optical theodolite is required for all sites using RDF tracking equipment. The theodolite serves several purposes. Initially, the theodolite is used to determine limiting angles at the sites. The limiting-angle diagram that is gained from using the theodolite to sight on obstructions along the horizon provides an accurate idea of when winds at a given azimuth and elevation will become inaccurate and should be considered missing. The theodolite also serves to ensure the tracking equipment is operating properly. This is accomplished by optically sighting a balloon and tracking it at the same time the tracking equipment follows the signal. The readings are synchronized and taken each minute of the observation. The readings are compared to verify if the tracking equipment is aligned properly or needs adjustment.

5.2 Limiting Angle Zone. The limiting-angle zone for NWS sites will be regarded as 6 degrees in elevation above the horizon or above objects, except trees, on the horizon. In azimuth, the zone extends 6 degrees from each side of the object. In the case of trees that extend more than 6 degrees in elevation above the horizon, the limiting- angle zone will extend in elevation to an angle that just clears the top of the tree or trees, and in azimuth to the edge of the tree or trees.

5.2.1 Accuracy of Data. The accuracy of the Ground Meteorological Device (GMD) and WBRT tracking is seriously affected whenever the elevation-angle readings fall within the limiting-angle zone, the boundaries of which vary with the individual site installation. Wind data computed from elevation-angle readings outside the limiting-angle zone will usually be regarded as accurate. No wind data will be computed from elevation-angles that fall within the limiting-angle zone.

5.2.2 Obtaining Limiting-Angle Data. Set up the theodolite as near as possible to the rawin set at approximately the same height as the center of the antenna. Carefully level and orient the theodolite to true North.

- a. The observer should at a minimum, note and record on a plain sheet of paper the elevation angle of the horizon or objects in the line of sight for each 10 degrees azimuth. For obstructions, such as trees, power lines, guy wires, and antennas, note a sufficient number of additional azimuth and elevation angle readings so that the shape of the obstruction, as seen by the antenna, can be approximated. Include the distance in feet to the obstruction.
- b. Sites may then use a WS Form B-38 or a sheet of cross-section paper to plot the horizon. All elevation heights read should have 6 degrees added to the reading and the azimuth readings should have 6 degrees placed on each side of the readings.

The only exception is trees, which should not have 6 degrees added to either the elevation or to either side of the azimuth.

Note: No reading should have a value less than 6 degrees.

- c. After the limiting angle diagram is completed, the data should be entered into the MicroART computer by going into the "Station Data" screen and entering the elevation angles to the nearest 0.1 of a degree at the appropriate azimuth angle. When the data is entered the observer may then request a plot of the limiting-angle information and save it to the station.dat file on both the hard drive and a floppy diskette.

5.2.3 Updating Site Limiting-Angle Information. Stations should update their limiting-angle diagrams every 5 years or sooner if necessary. New building construction or cutting trees are common reasons to update the limiting-angle diagram on a more frequent basis.

5.2.4 Disposition of Limiting-Angle Information. At least two copies of the current MicroART station.dat diskette will be kept on station. One copy will be safeguarded and another will be accessible to the staff in case the file on the hard drive becomes corrupted. Additional copies of the station.dat file will be sent to the Regional Upper-Air Program Manager and the Upper-Air Program Office at NWS Headquarters. NCDC maintains a Master Station Information (MSI) file that contains all station information. If there are any changes to the station information NCDC will be notified. The copies at the region and at NWS Headquarters will be used to either rework or resume observations to investigate field problems. Inform NCDC of any changes to the station information.

5.3 General Theodolite Test. General theodolite tests will be performed upon receipt of a new or reconditioned theodolite and quarterly thereafter. When the theodolite is set-up, leveled and oriented, sight on a target object and record the indicated elevation and azimuth angles. Adjust the theodolite by 180 degrees in both the elevation and azimuth angles then move the theodolite back on the original target object and record the angles. If the resulting differences are more than 0.2 degrees in either azimuth or elevation, the observer should repeat the test. If the differences in either angle are again out of tolerance, another observer should attempt the test,

and if the results are outside the allowable 0.2 degree range, the theodolite should be returned to NRC and another theodolite ordered from NLSC.

Readings should be placed on the WS Form B-29 in the blocks labeled “Theodolite General Test”. The currency of this test and optical comparisons will be used in the final evaluation of upper-air site performance or awards.

5.4 Optical Theodolite Comparisons.

5.4.1 Purpose of Taking Optical Comparisons. Optical comparison should be performed at least once a quarter unless a Regional Operational Letter has been approved allowing a change to this policy. Optical comparisons are taken to ensure the radiosonde tracking equipment is operating properly and tracking smoothly.

NOTE: Optical comparisons are not required for GPS tracking systems.

5.4.2 Procedures for Taking an Optical Comparison. Optical theodolite readings are usually taken from a location within 125 feet from where the RDF tracking equipment is located. The theodolite is orientated using a minimum of two surveyed points within 400 feet of the theodolite. The theodolite is leveled and properly oriented. Procedures for leveling and orienting the theodolite should be followed using the instructions in FMH-3, chapter 6, page 6-6.

It is best to do the comparison on a clear day with some wind. Days with strong winds which may cause limiting angles and days with light winds that may cause elevation angles above 60 degrees should be avoided.

The pibal timer should be started when the release is initiated. It is extremely important that it is synchronized with the time of release. The optical readings will be compared to the readings automatically recorded each minute as entered by the MicroART software when tracking the balloon. The timer buzzer will sound 10 seconds prior to each minute. This 10 second warning is provided to alert the observer to get the balloon in the theodolite cross hairs and be prepared to take an accurate reading at the next observation of the buzzer.

The observer should attempt to lock-on to the radiosonde as early as possible using the sights mounted on top of the telescope and enter the angular readings on the WS Form B-17. Readings will not be used for the first 10 minutes of the observation due to rapid changes in the angular readings. Conditions for reliable readings have elevation angles above the limiting angles and less than 60 degrees.

Readings used in the computation will not begin until the eleventh minute after release. Readings should be taken for at least 30 minutes from that time. Azimuth angles should be read every minute, but compared only every 5 minutes. The emphasis of the comparison is on elevation angles. The elevation angles should be read and compared every minute. The WS Form B-17 should have the optical theodolite readings entered and have the differences noted with the radiosonde tracking equipment’s readings.

- a. Differences in azimuth readings will be entered every 5 minutes in column 3 subtracting the rawinsonde tracking equipment readings from the theodolite readings.
- b. Differences in the elevation readings will be entered each minute in column 5. Ground tracking equipment readings will be subtracted from the theodolite readings.
- c. Minute to minute changes will be entered in column 6. These readings will begin with subtracting the elevation difference recorded in column 5 starting at minute 11 from the minute 12 elevation difference. This process of subtracting the previous minute's angular readings from the next indicates the smoothness of the tracking.
- d. Column 7 is the square of the entries in column 6. These entries are tabulated for all minutes that have elevation readings between the limiting angles and 60 degrees. These readings when added together and divided by the number of entries in column 7 provide an average change. The observer should then go to the "Table of Average Root Mean Squares" and locate the appropriate column that contains the average change. The average RMS value is shown to the right and should be placed in column c.

5.4.3 Reporting RMS Values and Corrective Action. The RMS values should be reported on the next WS Form B-29 in the blocks labeled Rawin-Rabal Comparison. The latest RMS value along with the date of completion should be entered. The following actions will be taken if RMS values fall within a given value.

- a. Whenever the RMS value is 0.050 or less:
 - (1) The electronics technician should examine the forms to determine the need for maintenance, and initial the forms after which they will be forwarded to the regional headquarters with the current WS Form B-29.
 - (2) If the electronics technician is expected to be absent from the station for more than 7 days, the forms will be forwarded without initials to the regional headquarters with the current WS Form B-29.
- b. Whenever the RMS value is greater than 0.050, hold the forms at the station until corrective action has been taken. After the action is completed, send the forms to the regional headquarters with the current WS Form B-29. If the RMS is between 0.050 and 0.080 and the station electronics technician is unable to complete corrective action within ten days, that fact, together with the reason for the delay, will be reported by email to the regional headquarters with a copy of the email placed in the station's maintenance records.

- c. Whenever the RMS value exceeds 0.080, emergency maintenance is required. If the station electronics technician is unable to take immediate corrective action to reduce the RMS to less than 0.050, the regional headquarters should be notified.

5.4.4 Disposition of the WS Form B-17. Copies of the WS Form B-17 should be sent to the regional headquarters. If corrective action is required, the form should not be sent until the correction has been completed. A copy of the WS Form B-17 should remain on station until the station closes or when networks are replaced by newer equipment or facilities. Transfer to new facility that assumes responsibility. This form, with other upper-air documentation, will be reviewed during upper-air site inspections from regional and national headquarters personnel.

6. Initial Certification of New Personnel. Certification involves three requirements. First, the person demonstrates proficiency to the satisfaction of the site supervisor. Second, the person passes a closed book examination with a minimum passing score of 80%. Third, the person passes a vision test or bring proof of corrected vision of 20/30 or better. The Snellen vision test should be used on site unless proof of visual acuity is provided from a certified optician or ophthalmologist. The Snellen Vision Chart may be obtained from (NLSC). Its ASN number is YTA-B-028A. These requirements are for persons without a current upper-air certification.

It is emphasized that all NWS upper-air operating systems require operator intervention. The observer knows how to perform routine and non-routine functions. This includes performing pre-release and in-flight actions to maintain a high success rate. The observer is expected to know how to edit and quality control data. This includes routinely checking and correcting software call-ups.

The regions may grant observers temporary authority to take upper-air observations under unusual situations not to exceed 60 days. Immediate steps should then be taken to formally certify observers in this category before the 60-day expiration period. This certification waiver should only be used in extreme circumstances. Requests granted by the regions is forwarded to the NWS Upper-Air Program Office for record keeping purposes.

6.1 Request for Observer Examination. Request for the upper air examination may be made using WS Form B-25, the Request for Observer's Examination or Certification. This form may also be used to validate or invalidate a certificate. This is typically sent to the Regional Upper-Air Program Manager by the site supervisor. The submission of the WS Form B-25 is optional, and is at the region's discretion. Email notification or other means by the field site to the Regional Upper-Air Program Manager is the region's discretion.

6.2 Examination Requirements. Precautions will be taken to ensure the security of the certification examination. No portion of the examination will be copied without approval of WSH. All initial examinations are to be taken closed book and field supervisors should designate responsible proctors. All examinations will have a 2 hour time limit, with completion in one session. Currently certified observers becoming re-certified with RRS take a proctored open book certification exam. The exam is to be completed within a 2 hour limit. The observer has to also demonstrate proficiency in required tasks and take a minimum of three live observations

with a RRS certified observer prior to being certified for RRS observations. If an observer fails to make a passing grade, another certification examination may be given to the observer after two weeks of additional training and instruction. Requests for grade changes due to ambiguous test questions will be forwarded through the Regional Upper-Air Program Manager to the NWS Upper-Air Program Office.

The NWS Regional Directors and the NWS International Activities Office including persons they may designate will certify all observers who meet the qualifications. WS Form 10-13-1, "Certificate of Authority to take Weather Observations," will be used to document certification.

6.3 Recency of Experience. An observer will take and record at least one complete upper air observation every 120 days. Persons involved in the daily use of upper air observations, training of upper-air personnel, or supervision of the upper-air program are exempt from the 120 day requirement. However, these personnel should have passed the upper-air certification at some point in their weather service career.

6.4 Lapsed Certificate. A temporary suspension of the certificate's validity may be caused by failure to revalidate within 90 days of transfer, degradation of an observer's eyesight, recency of experience, or poor observer performance. A lapsed certificate may be reinstated by the issuing authority upon the recommendation of the field supervisor when conditions causing the temporary suspension have been corrected.

6.5 Canceled Certificate. This action revokes the certificates validity. Certificates are canceled when:

- a. Observer terminates employment.
- b. A certificate has lapsed for 90 consecutive days.
- c. An observer fails to maintain the certification qualification as stated in this appendix.

A record of canceled certificates will be maintained by the regions. Each canceled certificate will be maintained until no longer needed for reference, and then destroyed. In the event of litigation, the certificate or record will be retained for an additional 2 years after the completion of the litigation, then destroyed.

6.6 Validation upon Transfer. Personnel certified to take upper air observations receive a new certificate from the gaining region if transferring outside the region. The field supervisor has 46 days from the time of arrival at the new station for personnel to demonstrate proficiency and have their certificate recertified with the gaining region. Certificates not validated and/or reissued by issuing authority within this time frame become lapsed. An observer with a lapsed certificate may not take official upper-air observations.

6.7 Vision Requirements. Persons certified to take upper-air observations have to be able to visually find the balloon and adjust the tracking antenna after release. This task plus visually

checking prior to making a release for aircraft or obstructions, requires the observer to have good visual acuity.

A Snellen Test Chart measuring 24 x 11 inches should be used. There should be adequate illumination. The chart should be 20 feet from the person being tested. Each eye should be examined separately with the other covered by an opaque shield. The row of smallest letters read by the person determines the denominator of the fraction used to grade visual acuity. The numerator is always 20: e.g. 20/20, 20/30, 20/40. If no more than two letters are missed in a line, the visual acuity will be graded as of that line.

- a. Distant vision of not less than 20/30 (Snellen) in the better eye, corrected if necessary.
- b. Near vision, corrected if necessary, that meets the Jaeger #2 standard.

6.8 Changes in Radiosonde Types. An observer with a current upper-air certificate transferring to a site using a different instrument will be required to take an open-book exam. This examination will deal with specific questions relating to the new type instrument. This will also be the case for certified observers switching from RDF to GPS radiosondes.

It is the site supervisor's responsibility to ensure all observers certified to take upper-air observations are proficient in handling routine situations and know the availability of resources and reference material to resolve unexpected difficulties. All observers will take a minimum of three live observations with a certified observer prior to being certified or certified with another instrument.

7. Ordering Upper-Air Supplies and Expendables. Usually the site supervisor will assign a focal point to handle ordering supplies and expendables for the upper-air program. The only exception is that radiosondes are ordered, shipped, and paid by WSH. Other expendables will be ordered through NLSC. Sites ordering expendables from sources other than NLSC will need to have permission from the regional or national headquarters upper-air staff.

Sites should maintain at a minimum, a 1 month inventory for all supplies. Supplies should never exceed 3 months. Stations in remote locations (Alaska, Pacific) may keep up to a 4 month supply. This should allow enough time for shipments to arrive without the operations being effected. NLSC has a maximum shipping authorization on certain stock; sites will not attempt to circumvent this by stockpiling unrealistic quantities.

Upper-air stations cannot allow supplies of radiosondes, balloons, train regulators, or parachutes (at those sites requiring parachutes) to drop below 30. Twine supplies cannot drop below a two week supply. Balloon gas supplies cannot reach low levels (less than a week supply) as well.

If, for any reason, radiosonde, balloon, or parachute supplies drop just below 30, the office contacts their Regional Office upper air Program Manger and WSH as soon as possible. Failure to do this policy may result in supplies running out and missed soundings.

7.1 Handling of Surplus Flight Train Equipment.

a. Batteries

All Upper air offices will follow the guidance below on handling spare radiosonde batteries until further notice.

- (1) The shelf life of a radiosonde battery is 3 to 5 years. If the battery is more than 5 years old it needs to be discarded following local disposal/recycling guidelines.
- (2) If the spare battery has a broken seal or is "puffy" to the touch, the battery is probably no good and it needs to be discarded following local disposal/recycling guidelines..
- (3) Sites that have more than 15 spare batteries need to contact their Regional Office Upper air manager to find another office or two to take some. If no office in their region will take any then the Regional Office Upper air Manager will contact WSH, to help find sites elsewhere in the network that will take some.
- (4) ***Sites using Sippican radiosondes:*** If there are no takers of the spare Sippican batteries then each time a sonde is rejected, a ***usable*** spare battery (1 year or less old) will be placed inside the sonde before shipment to NRC.
- (5) ***Sites using Vaisala radiosondes:*** If there are no takers of the spare Vaisala batteries then each time a sonde is rejected, the ***oldest*** spare battery in in the office will be placed inside the sonde before shipment to NRC.
- (6) As offices transition over to RRS, they send their surplus batteries and other MicroART supplies to another office.

b. Hygristors.

Supplies of surplus hygristors at offices using the B2 radiosonde cannot exceed 15 at any time. Sites that have more than 15 spare hygristors contact their Regional Office Upper air manager to find another office or two to take some. If no office in their region will take any then the Regional Office Upper air Manager will contact WSH, to help find sites elsewhere in the network that will take some. If there are no takers of the spare hygristors then each time a sonde is rejected, a ***usable*** hygristor (1 year or less old) will be placed inside the sonde before shipment to NRC.

7.2 Rejected Radiosondes, Balloons, and Parachutes. The upper air offices ships to NRC rejected radiosondes at least every quarter and never allows rejects to pile up in the office. Failure to do this may result in rejects being returned beyond the warranty expiration date. If this occurs NWS will receive no compensation for the rejected instruments. Rejected radiosondes are to be sent to NRC and to no other location unless authorized by WSH.

If the observer rejects a balloon or parachute they should contact NLSC to obtain a new one. If more than 3 balloons or parachutes are rejected during the month, the office contacts WSH and their Regional office Upper air Program Manager as soon as possible.

8. Accurate Station Data Information. It is essential that station data information be accurate and up to date. This information includes the following:

- a. Latitude and longitude to the nearest second for the baseline and balloon release points. Obtain from site surveys, blueprints and station information and description pages.
- b. Determine elevation to the nearest 0.1 meter for the baseline and release point. Baseline elevation is where the instrument is baselined. This height is also where the Precision Digital Barometer (PDB) should be kept. Release point height is considered 4 feet or 1.2 meters above the height of the inflation building floor. The station pressure is corrected for difference in elevation of the baseline point and the release point. See Table J-1.
- c. There are no baseline and release point height differences of 16 to 25 meters in the table. This is because there are no NWS sites with height differences within this range.
- d. If the release point height is higher than the PDB height, the correction is negative. If the release point height is less than the PDB height the correction is positive.

Pressure Correction in hPa Applied to Radiosonde Baseline Station Pressure							
Barometer Height Minus Release Point Height (m)	Barometer Elevation in Meters Mean Sea Level						
	-5 to 299.4	299.5-599.4	599.5-899.4	899.5-1199.4	1199.5-1499.4	1499.5-1799.4	1799.5-2199.4
0	0.0	0.0	0.0	0.0	0.0	0.0	0.0
1	0.1	0.1	0.1	0.1	0.1	0.1	0.1
2	0.2	0.2	0.2	0.2	0.2	0.2	0.2
3	0.4	0.3	0.3	0.3	0.3	0.3	0.3
4	0.5	0.5	0.4	0.4	0.4	0.4	0.4
5	0.6	0.6	0.6	0.6	0.5	0.5	0.5
6	0.7	0.7	0.7	0.7	0.6	0.6	0.6
7	0.8	0.8	0.8	0.8	0.7	0.7	0.7
8	0.9	0.9	0.9	0.9	0.8	0.8	0.8
9	1.1	1.1	1.0	1.0	1.0	0.9	0.9
10	1.2	1.2	1.1	1.1	1.1	1.0	1.0
11	1.3	1.3	1.2	1.2	1.2	1.1	1.1
12	1.4	1.4	1.3	1.3	1.3	1.2	1.2

13	1.6	1.5	1.5	1.4	1.4	1.3	1.3
14	1.7	1.6	1.6	1.5	1.5	1.4	1.4
15	1.8	1.7	1.7	1.7	1.6	1.5	1.5
26	3.1	3.0	2.9	2.8	2.7	2.7	2.6
27	3.2	3.1	3.0	2.9	2.8	2.8	2.7
28	3.3	3.2	3.1	3.0	3.0	2.9	2.8
29	3.4	3.3	3.2	3.2	3.1	3.0	2.9
30	3.6	3.5	3.4	3.3	3.2	3.1	3.0

Table J-1 - Pressure Correction for Difference in Baseline and Release Point Heights

- Notes:**
- (1) Add 4 feet or 1.2 meters to the inflation buildings floor to get the release point height.
 - (2) Converting to meters, multiply the height in feet by 3.28.
 - (3) **Elevation height in “Station Data Entry” screen of MicroART is at the release point.**
 - (4) MicroART limits entry of latitude and longitude to the nearest minute and elevation to the nearest meter. However, the RRS workstation will allow entries of latitude and longitude to the nearest tenth of a second and heights to 0.1 meters or more.
 - (5) WMO, Weather Bureau Army Navy (WBAN), and SID are kept current and up to date.
 - (6) Primary and backup communication lines change and are tested for functionality at regular intervals.

APPENDIX K - STATION SAFETY

<u>Table of Contents:</u>	<u>Page</u>
1. Introduction.....	K-1
2. WS Form B-48, Upper Air Program Review Guide.....	K-1
3. Upper-Air Safety Issues Inside the Office.....	K-2
4. The Upper-Air Inflation Building.....	K-2
4.1 Generic Safety Issues for All Inflation Sites	K-2
4.1.1 Outside the Inflation Building	K-2
4.1.2 Inside the Inflation Building.....	K-3
4.2 Hydrogen or Natural Gas Sites	K-4
5. Safety Issues Prior to Release.....	K-6
6. Safety Photos	K-7

Figures

K-1 Cylinders Secured Improperly.....	K-7
K-2 Properly Secured Cylinders	K-8
K-3 Ungrounded Overhead Door Railing.....	K-9
K-4 Cylinder Cart - Not allowed.....	K-9
K-5 Unauthorized Hose	K-10
K-6 Unauthorized Manifolding of Cylinders.....	K-10
K-7 Authorized Personnel Only Sign & Hydrogen No Smoking.....	K-11
K-8 Safety Posters.....	K-11
K-9 Foot Plate at Top of Stairs	K-12
K-10 Brass Non-Sparking Wrenches.....	K-12
K-11 Ceramic Scissors.....	K-12

1. Introduction. Safety is a vital part of the upper-air program. Each site will have the required safety equipment and documentation on station. The site supervisor is responsible to ensure that proper safety procedures and practices are being followed. This emphasis on maintaining a safe work environment is especially important at sites using hydrogen or natural gas for inflation.

2. WS Form B-48, Upper Air Program Review Guide. The WS Form B-48, the Upper-Air Program Review Guide is an excellent starting place for the site supervisor to ensure safety guidelines are being met. Sections III and IV, of the checklist provides a list of items typically checked during an upper-air site inspection.

3. Upper-Air Safety Issues Inside the Office. These tasks inside the office need to be performed to ensure the upper-air program's safety:

- a. A posting of the location of wires, antennas, and other obstructions throughout a 360 degree circle within a 1/4 mile of the launch site. This chart will be prominently posted by the upper-air workstation inside the office. The station manager should advise all the staff of the inherent dangers of trying to disentangle a balloon train from wires of any kind that carry an electrical current.
- b. Preparation of the water-activated batteries will follow the manufacturer's instructions. Care will be exercised not to allow battery solution to drip or spill on personnel or equipment. If solution should spill on the skin of the observer, the area should be flushed immediately with clean running water.

4. The Upper-Air Inflation Building. The upper-air inflation building is where most of the items dealing with safety are based. Responsibility for safety lies with all on-site personnel. A qualified technician will, at a minimum of every 6 months, check and document a safety check of the equipment to see that it is in safe operating condition and grounded properly. The observers will do a visual inspection of the inflation building and inflation room prior to and during the inflation process. The site supervisor should stay alert to issues that need attention and act promptly to ensure problems are resolved.

4.1 Generic Safety Issues for All Inflation Sites. There are generic aspects with the inspection of the inflation building that are common to both hydrogen and helium sites. There are also items that pertain strictly to hydrogen sites.

4.1.1 Outside the Inflation Building. The following items will be routinely checked outside the inflation building:

- a. The area surrounding the inflation building should be clear of obstacles, including snow and ice, and be level to allow the observer an environment that is safe to launch the balloon.
- b. The areas around the overhead doors and side doors should be free of ice and snow. Salt or ice melting particles will be available in case of icy conditions.
- c. The building, when not in use, should have all doors locked to ensure unauthorized persons do not have access to the area.
- d. The foot and hand railings will be secure and sturdy. A foot rail or kick plate should be installed at the top of the stairs leading up to the radome to eliminate the potential of personnel possibly slipping off or falling from the stairs during icy or slippery conditions (See Figure K-9).
- e. All outside lights should work and the area should be well lit.

- f. A communication system is required and should be turned on prior to an individual going out to the inflation building. This is to ensure an open line of communication is kept with the office. This requirement is especially needed for launches during inclement weather and to ensure that if an observer is injured there is a means of calling for help.
- g. Overhead doors and louvers should be in good operational condition.
- h. Entrance to the stairwell leading to the top of the roof or radome will be either secured or have an “Authorized Personnel Only” sign chained across the stairs (See Figure K-7).

4.1.2 Inside the Inflation Building. The following items are required inside the inflation building at all sites:

- a. The floor will be kept clean and free of debris.
- b. Approved fire extinguishers will be placed inside the inflation building and also inside the radome and inspected annually by a certified expert and visually inspected and initialed off monthly by station personnel.
- c. The inflation table will be clean and free of dirt.
- d. Expendable items stored in the inflation building will be stored within electrically grounded metal cabinets.
- e. The interior of the building will be well lit.
- f. The gas cylinders will be properly marked and secured individually or possibly in pairs to ensure they can not topple over (See Figures K-1 and K-2).
- g. Caps will be on all cylinders full and empty not connected to the supply line.
- h. Cylinders will be pre-positioned to keep personnel from moving cylinders themselves. Compressed gas cylinders are not rolled or stored on their sides, dragged or slid. Never use a cart to move cylinders as indicated in Figure K-4.
- i. Cylinders will not be manifolded. (Supply hose feed off only a single cylinder). (See Figure K-6 for unauthorized cylinder manifolding).
- j. First-aid kits will be available in the inflation building, the radome, and the hydrogen generator building.
- k. Spare UL approved regulator available.

- l. Fill rate follows NWS instructions.
- m. The poster for the “General Safety Rules for Cylinders” will be displayed in the cylinder storage area. The poster for “Non-Hydrogen Fire” will be displayed on the wall inside the inflation room (See Figure K-8).

4.2 Hydrogen or Natural Gas Sites. The following rules apply to sites using hydrogen or natural gas:

- a. Only spark-proof tools will be used in and around a hydrogen environment. Brass tools are available through NLSC (See Figures K-10 and K-11).
- b. Smoking or lighting of flammable materials will not be allowed within 25 feet of buildings where hydrogen gas is stored or generated. Each site will have signs prominently displayed on the exterior of each side of the inflation building saying “Danger Hydrogen - No Smoking Within 25 Feet”. These metal signs can be obtained through NLSC using ASN P810-3.
- c. All overhead door runners will be electrically grounded. Grounding can be accomplished by using a grounding wire and connecting it to a nearby grounding rod. The rollers will have a conductive lubricant applied at frequent intervals (See Figure K-3).
- d. The hydrogen fill system including the inflation hose, nozzle, and inflation table will be grounded with the frame of the building and have a resistance of less than 25 ohms. (Resistance will be checked at least every 6 months by a qualified technician).
- e. An anti-static mat will be placed at the end of the inflation table where the observer stands during the process of attaching the balloon to the nozzle and tying of the balloon after inflation.
- f. Safety posters will be prominently displayed in the inflation room and cylinder storage area. These posters or signs are available through NLSC. The ASN range P810-4A through P810-4E. The entire set of 5 posters can be ordered using ASN P810-4 (See Figure K-8).
 - (1). P810-4A - General rules for hydrogen fire prevention.
 - (2). P810-4B - Safety rules for hydrogen cylinders.
 - (3). P810-4C - Balloon rupture procedures.
 - (4). P810-4D - Hydrogen-fed fires.
 - (5). P810-4E - Non-hydrogen Fire.

- g. New personnel will not be allowed to work in and around hydrogen generators unless accompanied by a qualified operator. Each operator is certified prior to working alone.
- h. All electrical switches, lights and wiring have to meet the code or standards required by the National Fire Protection Association (NFPA) for hydrogen safety. This requires the installation of non-explosive designed wiring, lighting, and switches.
- i. Only a minimal amount of expendables will be stored inside the inflation building. Combustible expendables will be placed within a metal storage cabinet.
- j. At least 2 fire extinguishers will be placed in the inflation room. One of the extinguishers will be at least 20 lbs and be placed near the exit. Additional 10 lb or larger extinguishers will be placed in the cylinder storage area and in the radome. The extinguishers will be inspected monthly and annually.
- k. Vents in the inflation building will be placed near the top of the inflation building and will be at a minimum of at least 1 square foot for each 1,000 cubic feet of space within the inflation building. The vents will not be obstructed in any way.
- l. Trash cans should be kept outside the inflation building. They should be metal and have a lid securely in place.
- m. Cylinders will be stored and transported in an upright condition. The cylinders will be secured individually or in pairs. Either a non-metallic chain or cable or a metal chain or cable with a plastic covering will be used to eliminate the potential for a spark (See Figure K-2).
- n. A limited number of hydrogen cylinders will be stored on site. This should usually be limited to 15 cylinders. Exceptions to this will be approved by the Regional or National Safety Officer.
- o. Only approved dual stage hydrogen regulators, hoses, and equipment will be used. Engineering Handbook 1 lists authorized equipment stocked at NLSC (See Figure K-5).
- p. Hydrogen cylinders will not be manifolded (See Figure K-6).
- q. In the event of a balloon rupture, the observer will carefully open the side door and the overhead door at least 18 inches to allow the area to ventilate properly. The observer will then walk outside the building and wait 15 minutes prior to beginning to fill another balloon.

- r. Devices used to heat the inflation building or the radome above the inflation building will meet Class I, division 2, Group B specifications in the National Electrical Code (NEC).
- s. Interior wiring, light switches, and light fixtures inside the inflation building will be explosion proof.

5. Safety Issues Prior to Release. The following should be followed prior to launching a balloon:

- a. Sites located within 5 nautical miles of an active runway for a controlled airport will contact the controlling authority to coordinate the balloon release.
- b. At all sites, the observer will check the horizon to ensure there are no aircraft or other activity that the balloon might interfere or endanger. If aircraft or other activities are present, the observer will postpone the launch until it is safe to launch.

Note: The requirement for filing a Notice to Airmen (Notam) is no longer necessary. The radiosondes used by the NWS do not meet the size and weight requirements that demand a Notam be filed. This does not however, eliminate the coordination call if a site is located within 5 Nautical Miles (nm) of an active runway at a controlled airfield.

Part 101 and/or any NOAA WX Balloon operations are authorized everywhere. NOAA and other groups are to follow their normal coordination process and procedures for releasing these balloons.

(U.S., Canadian and Mexican registry) Part 135 operations are authorized everywhere IFR and VFR, including the TFR's, as long as the operation within the TFR's is strictly conducive to that required for landings and departures.

6. Safety Photos.



Figure K-1 - Cylinders Secured Improperly



Figure K-2 - Properly Secured Cylinders



Figure K-3 - Ungrounded Overhead Door Railing



Figure K-4 - Cylinder Cart, Not Allowed



K-5 - Unauthorized Hose



Figure K-6 - Unauthorized Manifolding of Cylinders



Figure K-7 - Authorized Personnel Only Sign & Hydrogen No Smoking



Figure K-8 - Safety Posters



Figure K-9 - Foot Plate at Top of Stairs



Figure K-10 - Brass Non-Sparking Wrenches



Figure K-11 - Ceramic Scissors

**APPENDIX L - RADIOSONDE SURFACE OBSERVING
INSTRUMENT SYSTEM (RSOIS)**

1. Introduction.....	L-1
2. RSOIS Sensors.....	L-2
2.1 Vaisala/Handar Wind Sensor.....	L-2
2.2 R.M. Young Wind Sensor.....	L-3
2.3 Temperature/Humidity Sensor.....	L-4
2.4 Sensor Accuracy	L-4
3. RSOIS Base Station	L-4
4. Remote Processing Unit (RPU)	L-5
4.1 RPU Components.....	L-6
4.2 Cabling and Power.....	L-7
4.3 Lightning Protection	L-8
5. Antenna.....	L-8
6. RSOIS Siting.....	L-9
7. Maintenance.....	L-9

Figures

L-1 RSOIS Tower.....	L-2
L-2 VAISALA/Handar 425AHW Wind Sensor.....	L-3
L-3 R.M. Young 05103 Wind Monitor	L-3
L-4 Temperature/Humidity Sensor.....	L-4
L-5 Expanded View of Components	L-4
L-6 RSOIS Base Station.....	L-5
L-7 Remote Processing Unit (RPU).....	L-6
L-8 RPU Components.....	L-7
L-9 Power and Cabling.....	L-8
L-10 Yagi Antenna	L-8

1. Introduction. This appendix describes the Radiosonde Surface Observation System (RSOIS). The instructions should provide the user with additional information that may help to better understand how each component and the overall system operates.

The RSOIS gathers and reports data on weather parameters at the surface to be used in the analysis of the upper air data obtained during an observation. In routine operations, the sensors mounted on a tower at the launch site, provide data to a processor in a metal enclosure. Also

mounted on the tower is the Remote Processing Unit (RPU). The processor in turn feeds data to an rf modem (or fiber optic modem) housed in the same enclosure. **The data are transmitted to a unit called the Base Station where the weather observer can monitor the information.** The Base Station is a radio processor and LCD display housed in a single breadbox-sized unit.

2. RSOIS Sensors. The RSOIS provides temperature, dew point, relative humidity, wind speed, and wind direction readings. Pressure readings are gathered from the Paroscientific Digital Barometer (PDB) located inside the office at the baseline location. Figure L-1 shows a typical RSOIS tower with the sensors identified.

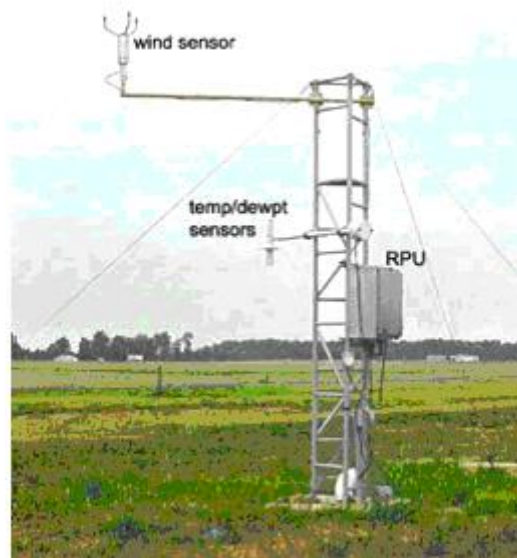

Figure L-1 – RSOIS Tower

2.1 Vaisala/Handar Wind Sensor. The wind sensor provides wind speed and direction. The wind sensor does not depend on mechanical movements as do the traditional rotating-cup anemometers and wind vane direction indicators. Measurements of both averaged wind speed and direction are reported based on the transit times for ultrasound between the spikes of the wind sensor that are fixed in position. The wind sensor is a Vaisala/Handar 425AHW Ultrasonic Wind Sensor and is considered a 'smart' sensor.

It contains a microprocessor that computes the averages and every 5 seconds supplies:

- a 5-second average wind speed.
- a 5-second average wind direction.
- heater circuit quality and other data.

The heater is thermostatically controlled and prevents freezing rain or snow buildup. It is positioned 10 meters above the ground.



Figure L-2 – Vaisala/Handar 425AHW Wind Sensor

2.2 R.M. Young Wind Sensor. The R. M. Young Wind Monitor (WM), model 05103, is a temporary replacement to the Vaisala/Handar wind sensor at specified Weather Forecast Office locations. The WM is a propeller/vane wind sensor, with a long history of reliable use at many Met sites around this country. This sensor is not polled, it produces two analog outputs: a sine wave with the frequency indicating wind speed, and a resistance proportional to azimuth. These analog signals are computed to produce the same 5-second vector average wind speed, vector average wind direction, and other data as the Vaisala/Handar 425AHW wind sensor. The WM has no heaters therefore it is only used at low ice risk sites. The WM is positioned at the same location as the Vaisala/Handar 425AHW.



Model 05103 © 2003 Campbell Scientific (Canada) Corp.

Figure L-3 – R.M. Young 05103 Wind Monitor

2.3 Temperature/Humidity Sensor. The contained sensors are housed within a Gill Aspirated Radiation Shield which reduces radiation errors to less than 0.1°C. The sensors are located approximately 2 meters above the ground.

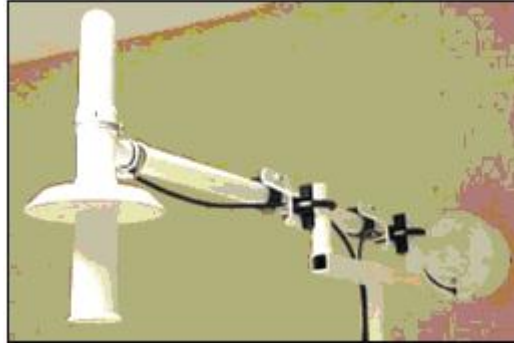

Figure L-4 – Temperature/Humidity Sensor

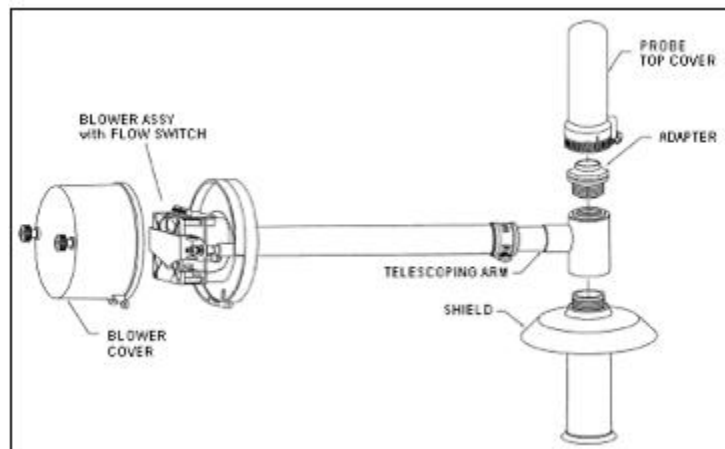

Figure L-5 – Expanded View of Components

2.4 Sensor Accuracy.

Temperature - $\pm .2$ degree C Dew point - ± 2.0 degree C (5 Minute Average)

Relative Humidity - $\pm 3\%$ (5 Minute Average)

Wind Direction - ± 2 degree Wind Speed - $\pm 3\%$ (2 Minute Average)

3. RSOIS Base Station. Readings are displayed on the RSOIS Base station on a Liquid Crystal Display (LCD). (See Figure L-6). If the base station is receiving data, the data light illuminates every 5 to 7 seconds.



Figure L-6 – RSOIS Base Station

Wind Speed and Direction Readings:

- SP:** The current 2-minute average wind speed.
- GU:** Gust speed and refers to the max wind speed in the past 10 minutes.
- PK:** Indicates the peak 5 second wind speed in the past 2 minutes.
- WD:** Is the current 2-minute average wind direction.
- WC:** Is 0 for steady winds and set to 1 if the current wind speed is > 6 knots, and the total wind direction range in the current 2-minute average is 60 or more.

Temperature, Dew point and Relative Humidity Readings:

- AT:** Is the current 5-minute average temperature in °C.
- DP:** Is the current 5-minute average dew point temperature in °C.
- RH:** Is the current 5-minute average relative humidity by %.

4. Remote Processing Unit (RPU). The RPU, mounted on the tower, is housed in a stainless steel enclosure. When powered within a minute, the RPU should be collecting and transmitting data.



Figure L-7 – Remote Processing Unit (RPU)

4.1 RPU Components. The RPU contains:

- a. The System Data Logger (SDL).
- b. Power supply.
- c. 12-volt backup battery.
- d. Spread spectrum radio.
- e. fiber optic modem.
- f. Sensor ports.
- g. Zeno-3200 SDL controls the sensors, logs data, performs averaging, formatting and other calculations, and controls communications. It does multi-tasking which allows simultaneous sensor sampling and communication.
- h. The backup power is provided by a 12 VDC, 38 amp-hour YUASA battery that independently powers the RSOIS for approximately 30 hours operation depending on temperature.

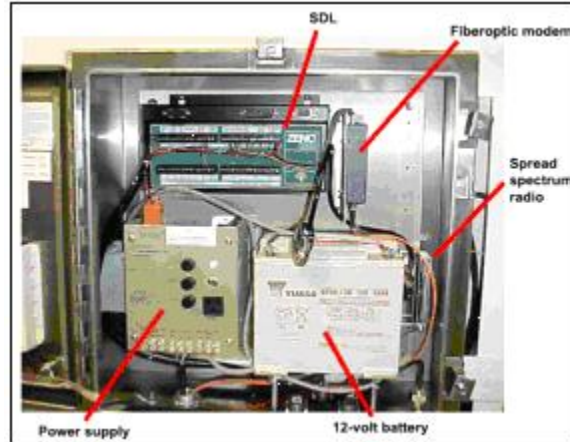

Figure L-8 – RPU Components

- i. Watchdog Timers- In remote electronic systems, it is possible that large electrical surges from sources such as excessive Strong Radio Transmissions (RFI) or lightning will scramble the software in the RAM or operating memory. In order to verify correct operation of the equipment, watchdog timers are built into the ZENO-3200.
- j. The system also contains software that examines data from the sensors to detect *common faults* and to ensure that the sensor is operating within range. If the sensor readings should fail any of their tests, an alarm message is logged and transmitted with the next data transmission.

A 32-bit Built-In-Test (BIT) field is used to convey information on a large number of warnings.

Other ZENO-3200 self-tests include:

Analog input zero-offset reading.

EEPROM Read/Write status.

Logging-memory status.

System power.

Internal temperature.

Real-time clock.

Note: The SDL's clock uses a 10-year lithium battery which is independent of the system backup battery. The clock is calibrated to give an accuracy of 5 seconds per month.

4.2 Cabling and Power. In routine operations the RPU is powered by AC entering through the base of the enclosure. This particular picture shows fiber optic cable that is used for communication with the base station. The RPU can support either radio communication or use of

a fiber optic cable driver, but not both simultaneously, (See Figure L-8).

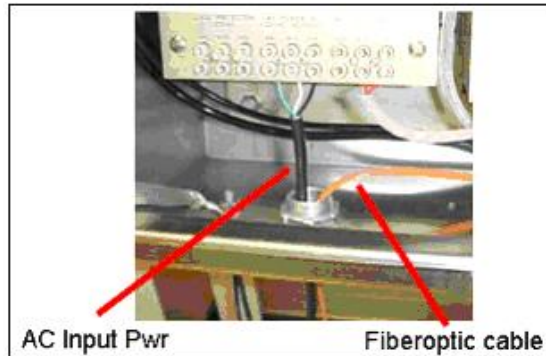

Figure L-9 – Power and Cabling

4.3 Lightning Protection. The lightning protection and diversion of the RPU is in addition to protection provided by the tower-mounted lightning rod.

The system employs these levels:

- a. The tower is connected as directly as possible to an earth grounding system.
- b. Induced currents are diverted to earth ground via the metallic electronics enclosure.
- c. Resistor-capacitor decoupling networks acting in concert with resistor-diode networks are built into each line entering sensitive semiconductor devices.

5. Antenna. The tower-mounted antenna at the RPU is a Yagi meant for the 2400-2483.5 MHz frequency band. It has a length of 7 1/4 inches. With a 60° horizontal beam width it can be aligned visually. Orientation accuracy should be within $\pm 15^\circ$ to achieve maximum gain. The radio and antenna system provides up to 3 miles line-of-sight communications.



Figure L-10 - Yagi Antenna

6. RSOIS Siting. The RSOIS tower should be located within 200 meters of the radiosonde release point. It should be sited to provide readings that are free from effects of blocking from buildings or obstructions. It should be positioned away from blacktop or asphalt surfaces and over a grassy area.

Contact WSH for more detailed information on RSOIS siting and installation requirements. If the RSOIS is to be moved, contact WSH for consultation and final approval.

The RSOIS equipment is not to be used as an official backup to other observing systems. This observation system is strictly to be used with upper air observations.

7. Maintenance. Routine and preventative maintenance is required. This system is an official National Weather Service (NWS) observing system. It is explained in Engineering Handbook 9-904.

Go to https://www.ops1.nws.noaa.gov/Secure/ua_new.htm In Engineering Handbook (EHB) 9-201 look in Chapter 3 at Table 3-1 in EHB 9-201.

APPENDIX M - SPECIAL OBSERVATIONS

<u>Table of Contents:</u>	<u>Page</u>
1. Introduction.....	M-1
2. Administrative Responsibilities.....	M-1
2.1 Weather Service Headquarters.....	M-1
2.2 Regional Headquarters.....	M-2
2.3 Local Office.....	M-2
3. Types of Projects.....	M-2
4. Special Project Costs.....	M-3
4.1 Overtime Authorization.....	M-3
4.2 Expendables.....	M-3
5. Disposition of Data and Archive Files.....	M-3
6. Information Reported.....	M-3
7. When and Where to Submit WS Form A-22.....	M-4
8. Timeline for Upper-Air Special Projects.....	M-4

1. Introduction. Special observations may be requested by private enterprise and government agencies, on occasion. This appendix explains the approval, coordination and special project process to ensure proper documentation.

2. Administrative Responsibilities.

2.1 Weather Service Headquarters. Each prospective sponsor states in writing to the Director, Office of Climate, Water, and Weather Services, the sponsor’s request for special observations. The Special Projects Coordinator reviews the request and may recommend NWS support. The Special Projects Coordinator then coordinates and prepares the request in the form of a Memorandum of Understanding (MOU) and Reimbursable Agreement (RA). The documents will be submitted for the review and clearance of the Office of General Counsel (OGC) at the Department of Commerce. The responsibilities of Weather Service Headquarters (WSH) are to:

- a. Calculate total projected costs and coordinate with Region.
- b. Provide MOU and RA templates to the Sponsor and Weather Forecast Office (WFO). Refer to Appendix C, of chapter 10, NOAA Finance Handbook.
- c. Coordinate MOU and RA with parties and CFO2 submits signed agreement to

OGC for clearance.

- d. Coordinate with National Climatic Data Center (NCDC) to ensure Sponsor has access to high density upper-air data via File Transfer Protocol (FTP).
- e. Coordinate with CFO2 and NOAA divisions to reimburse the Sponsor and Regions, as needed,. Follow guidance in Chapter 10, of the NOAA Finance Handbook. <http://www.corporateservices.noaa.gov>.

2.2 Regional Headquarters. Upon receiving a letter of request, the Region will inform WSH of the request. If Region and WSH agree, the Region should administer the special project. The Region coordinates with field offices and prepare the MOU and RA, for the approval of the OGC (Department of Commerce). The Region then assumes the responsibilities listed in Section 2.1. For either WSH or Region prepared special projects, the Regional Upper-Air Manager will:

- a. Coordinate with the Field Office managers for their close review of the specific upper-air MOU and determine if the office can schedule overtime.
- b. Upon completion of Region-to-WSH coordination, the Region should send the WSH/Region Coordination Form, signed and dated, to the Special Projects Coordinator.
- c. Forward a copy of the RA to the Regional Budget Officer (e.g., W/ER5).
- d. Email one copy of the site's Form A-22 to the Special Projects Coordinator, WSH. The Field submits A-22's monthly, as needed.
- e. Ensure the Regional Budget Office prepares an amended RA to account for the actual field labor and material expenses (remember to exclude the cost of radiosondes).

2.3 Local Office. The local office examines staff schedules to assess office's ability to accommodate the overtime work. The local office will handle all special observations as routine operational observations concerning the naming, logging, transmitting, and archiving of upper-air observations and reporting rawinsonde performance. In addition, Form A-22, Report of Supplemental Observations, should be completed as described in Section 6.

3. Types of Projects. The primary requesters are NOAA, NASA, state and local government agencies who conduct research studies. Other requesters include university and private corporations who conduct research and develop technology. About 40% of projects directly support research in atmospheric and hydrological sciences, about 30% support air chemistry analyses, and 30% support various industries' activities. A research special project resembles this example.

Project Name: Formation and Dissipation of Surface Temperature Inversions.

Sponsoring Agency: University of Alaska at Fairbanks (UAF).

Schedule Period: September 1, 2009, thru September 30, 2010.

Times of Specials: Dependent on sunrise and sunset for each case study.

Maximum Number of Specials: 18 observations (3 IOPs of 6 flights each).

Ascension Numbers Assigned: Specials are assigned sequential ascension numbers.

Coded Message Transmission: All message parts (e.g., TTAA, TTBB, PPBB).

Upper-Air Files to Send: Each Special Flight's data file(s) is transmitted and archived as if each was an operational synoptic hour (i.e., 00utc and 12utc) observation.

NCDC Archive Required: Sponsor requests NCDC (828-271-4437) send all RRS BUFR files and Decoder to UAF contact person. Files will contain the .mdb files along with the thermal, header, and BUFR files.

4. Special Project Costs. The total project cost can be calculated from two figures, the per-observation-cost (at overtime rate) and the administrative fee.

4.1 Overtime Authorization. Unless precluded by local station management, overtime is typically authorized to conduct special observations.

4.2 Expendables. In nearly all cases, the site's common stock of radiosondes is used. On occasion, there might be a request to use special radiosondes, batteries, and associated equipment.

5. Disposition of Data and Archive Files. The NWS makes the data collected from the observation available in the standard coded message format as soon as the message is generated. The observation data is treated as another routine observation. The file is saved for archive and ultimately sent to NCDC.

6. Information Reported. Each WS Form A-22 should clearly document the special project. This form is useful for several reasons:

- a. It identifies the title and nature of the project.
- b. Shows the total number of special observations taken.
- c. Shows the total number of radiosondes used.
- d. Shows the release dates and times, with space provided for remarks on each observation.

- e. Shows the amount of overtime used per observation. This helps ensure Region is reimbursed for proper labor charges. (Maximum 3 hours overtime per observation is allowed).
7. When and Where to Submit WS Form A-22. The station is responsible for completing the WS Form A-22 each month that special observations are taken.
- a. The original WS Form A-22 is submitted to the Regional Upper-Air Program Manager with all pertinent information completed.
 - b. Email a copy to OPS22, upper-air stock inventory manager.

Retain a copy on station for 12 months.

8. Timeline for Upper-Air Special Projects.

T-9 Months – Sponsor writes letter of request to Director, OCWWS.

National Weather Service Headquarters
Director, Office of Climate, Water, and Weather Services
1325 East-West Highway
Silver Spring, Maryland 20910

T-8 Months – Director, Office of Services, responds with approval/disapproval.

T-7 Months - WSH provides the Sponsor and field office(s) templates for MOU and RA and initiates coordination.

T-6 Months - Regional Manager works with WSH to obtain final costs for each observation, administration costs, and informs Sponsor.

T-4 Months - NWS and Sponsor ratify the MOU and RA with signatures on hard copy.

T-3 Months – Office of General Counsel (OGC) clears the MOU.

T-2 Months - Sponsor internally coordinates and arranges the advance payment to NWS.

T-1 Month - CFO2 takes delivery of Sponsor's payment to NWS.

T-0 Month - Project Starts.

E+1 Month - Special Projects Coordinator calculates actual cost and informs Sponsor.

E+2 Months - Region receives the Amended RA to execute labor and expendables budget.

E+3 Months - NOAA/NWS sends reimbursement check to Sponsor.

End of FY - In the case of a multi-year MOU, the Special Projects Coordinator contacts the sponsor to learn if there are any amendments to MOU and RA.

T = Denotes start of Period of Performance. E = Denotes end of Period of Performance.

APPENDIX N - RADIOSONDE PREPARATION

<u>Table of Contents:</u>	<u>Page</u>
1. Introduction.....	N-1
2. MkIIA GPS Radiosonde Preparation.....	N-2

Figures

N-1 Unpacked Radiosonde	N-2
N-2 Unfolding Sensor Boom	N-3
N-3 Orienting Boom	N-3
N-4 Temperature Sensor	N-4
N-5 Lead Adjustment.....	N-4
N-6 Humidity Cap Removal	N-5
N-7 Hygristor	N-6
N-8 Set Frequency	N-7
N-9 Cut Wires	N-7
N-10 Battery.....	N-8
N-11 Activation Water Container	N-9
N-12 Twist Battery Wires	N-10
N-13 Connect the Ground Wires First.....	N-10
N-14 Connect the Wires First (Inside the Radiosonde)	N-11
N-15 Battery in Compartment.....	N-11
N-16 Station Information Label.....	N-12
N-17 Label on Radiosonde	N-12
N-18 Baseline Stand.....	N-13
N-19 Styrofoam Block	N-13

Tables

N-1 Frequency Selection Chart.....	N-6
------------------------------------	-----

1. Introduction. This appendix describes the observation preparation procedures for the MkIIA GPS radiosonde. In brief, follow these radiosonde preparation tasks:

- a. Unpacking a radiosonde.
- b. Unpacking and positioning the radiosonde sensors.
- c. Selection of the appropriate frequency (1676 to 1682 MHz).
- d. Preparing the radiosonde battery for operation.

- e. Attaching a radiosonde to the dereeler and balloon.
- f. Release of the radiosondes.

2. MkIIA GPS Radiosonde Preparation. Use the following methods to prepare the GPS radiosondes:

- a. Carefully remove the MkIIA radiosonde from its packing material (See Figure N-1). Inspect for damage in shipping, missing components or tears in the cardboard sleeve.



Figure N-1 – Unpacked Radiosonde

- b. Remove the plastic cover from thermistor arm, unfold and orient the thermistor arm (See Figures N-2 and N-3).

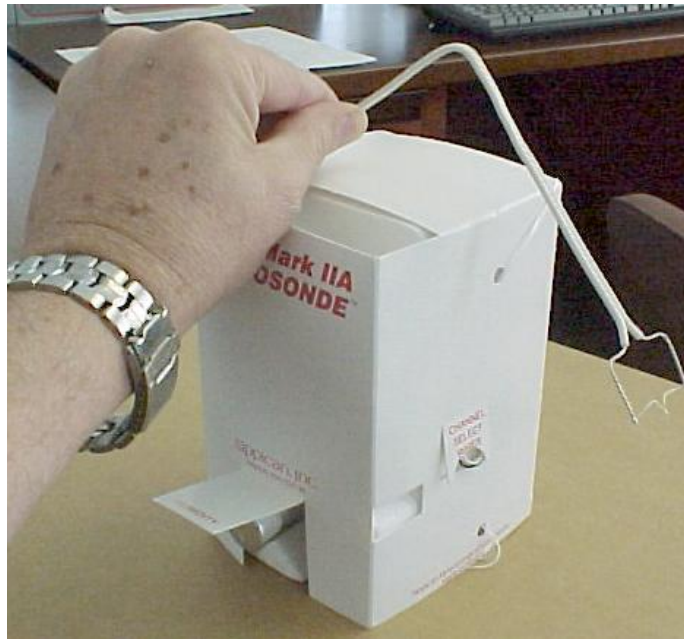

Figure N-2 – Unfolding Sensor Boom



Figure N-3 – Orienting Boom

CAUTION: *It is vital the sensor's boom be positioned as shown in Figure N-3. If the temperature boom is not set correctly, erroneous temperatures will result.*

- c. Inspect the temperature sensor for broken leads or a chip bead. If leads are bent gently bend the leads back into place using a pen or pencil (See Figures N-4 and N-5).



Figure N-4 – Temperature Sensor

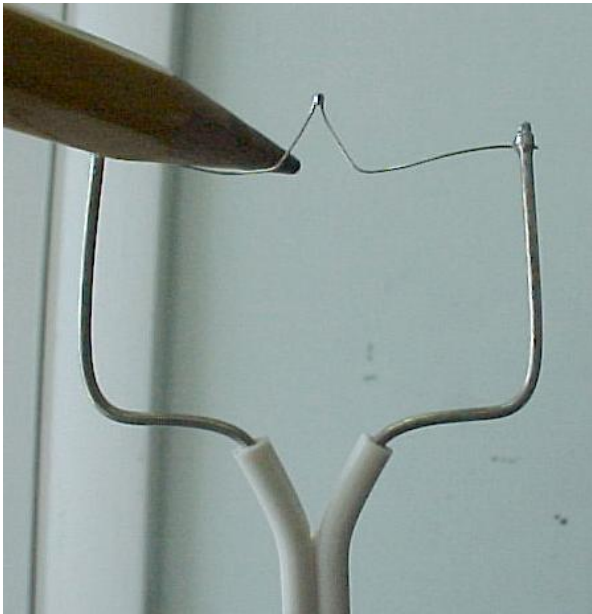

Figure N-5 – Lead Adjustment

- d. Remove the humidity sensor's protective cover. Twist the cover back and forth while evenly pulling on the cover (See Figure N-6). If necessary, use a pair of pliers to remove the cover. Inspect the hygristor, the black tape edges should be secure in the duct, and check for damage or defects. Orientation of the hygristor should be at an angle as shown in Figure N-7. If the hygristor is perpendicular to the duct, the instrument should be rejected. Do not touch the hygristor surface; doing so will alter the sensor calibration or resistance values. Close the humidity flap and secure it using masking tape provided with the radiosonde to keep light and precipitation out.

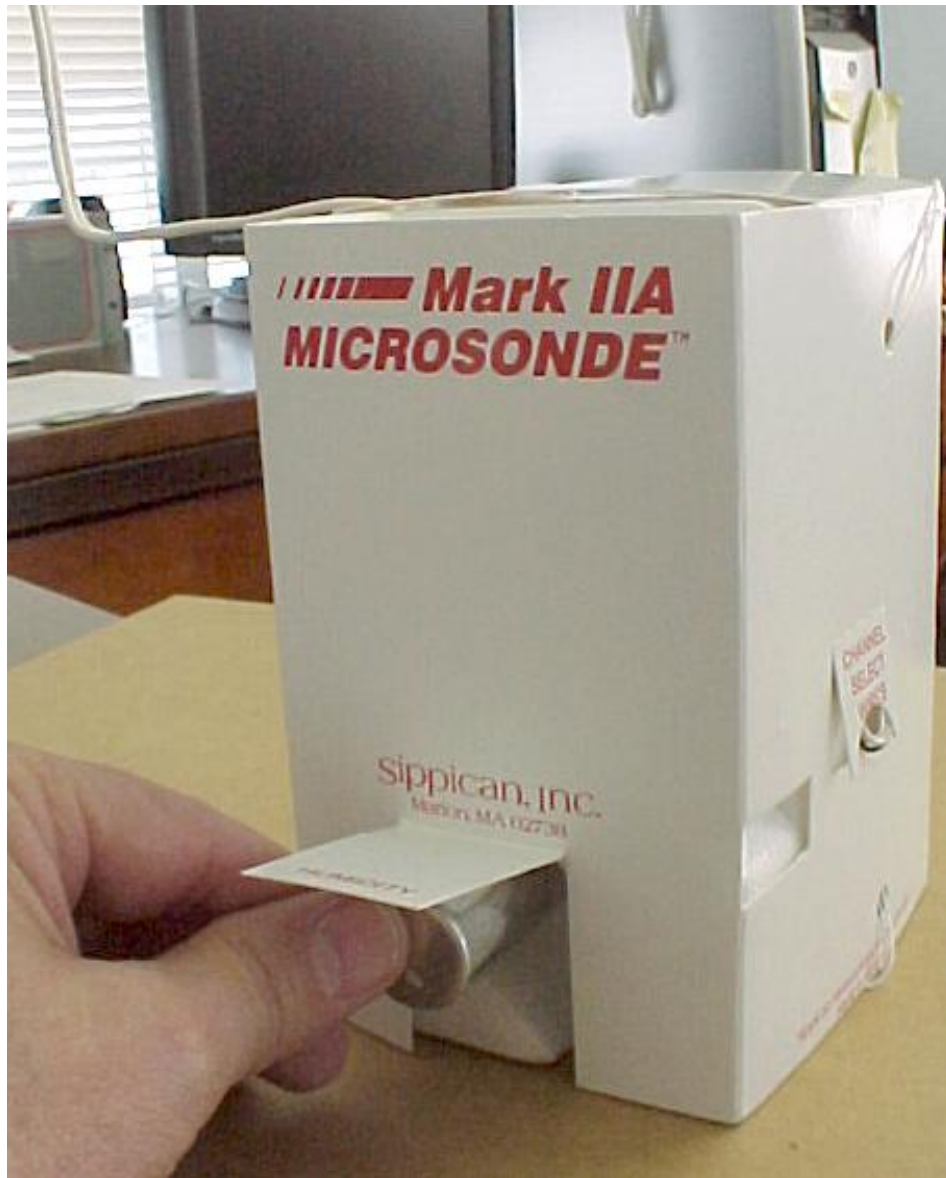

Figure N-6 – Humidity Cap Removal



Figure N-7 – Hygristor

- e. Setting the Frequency- The default transmitter frequency is 1676 MHz. Sites should use 1676 MHz unless there is an interference problem or an additional release is required. Table N-1 outlines the frequency channels available.

White	Black	1676	1678	1680	1682
Uncut	Uncut	X			
Uncut	Cut		X		
Cut	Uncut			X	
Cut	Cut				X

Table N-1 – Frequency Selection Chart

- f. Change the frequency by cutting the black and/or white wires located on the side opposite the deployed temperature sensor boom (See Figures N-8 and N-9).



Figure N-8 – Set Frequency



Figure N-9 – Cut Wires

- g. Lift the flap in the back of the radiosonde sleeve cover to expose the battery (See Figure N-10).



Figure N-10 – Battery

- h. Remove the battery from the battery compartment.
- i. Remove the battery from the vacuum sealed foil bag. Inspect the battery for damage to the connectors or wires.
- j. Place the battery with the label facing upward (Top-Up position) in a container of tap water at 10-25 degree Celsius. The top of the battery should be covered by a minimum of 1 inch of water (See Figure N-11).

NOTE: *In the label-up orientation, the battery will be positioned such that the wax layer on the opposite side will not trap air inside the cells while immersed in water.*

CAUTION: *Avoid getting the battery connector wet. Water in the connector may cause a short and significantly reduce the battery life and may result in the battery over-heating.*



Figure N-11 – Activation Water Container

- k. Leave the battery in the water for two minutes.

NOTE: *To avoid overheating or premature observation termination – The radiosonde should be released within 30 minutes of activation.*

- l. Use the following directions to remove the excess water from the battery:
- (1) Hold the battery in your hand wearing protective gloves and goggles with the label facing down (Top-Down position).
 - (2) Extend your arm and then swing the battery in an arc starting over your head and stopping abruptly at your knees.

NOTE: *Orient the battery so that the label is facing away from your palm. This way the excess water will be thrown away from the battery and not be trapped by the wax layer on the opposite side of the battery.*

- (3) Repeat the swinging motion approximately 10 times.
- (4) Examine the partially waxed sides of the battery for remaining excess water in the unwaxed areas. Repeat steps 2 and 3 if you find excess water on the battery.

CAUTION: *Excess water greatly increases inter-cell leakage, causing overheating of the battery and shorter battery life.*

- m. Place the battery in the plastic bag provided with the carton of radiosondes.
- n. Twist the radiosonde battery connection wires counterclockwise four turns. Also, twist the connection wires on the battery four turns the opposite (clockwise) direction (See Figure N-12).



Figure N-12 – Twist Battery Wires

- o. Place the battery in the radiosonde battery compartment such that the TOP label faces OUT of the compartment. By pushing the battery all the way into the bag and tucking the bag ends inside, the battery fits easier in the compartment.
- p. Connect the battery to the radiosonde battery connector. Connect the black or ground wire of the radiosonde to the black or ground lead of the battery (See Figures N-13 and N-14). Then connect the red or positive lead of the battery to the red or positive lead of the radiosonde.

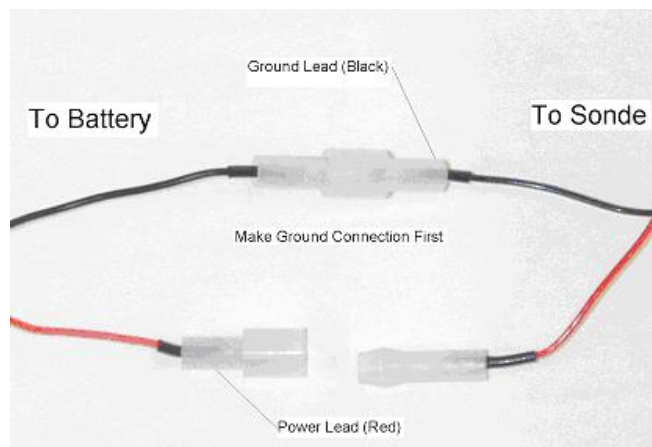

Figure N-13 – Connect the Ground Wires First

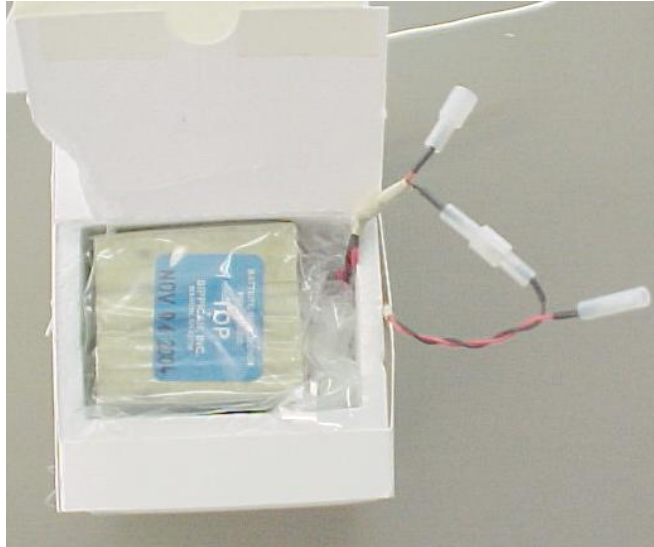

Figure N-14-Connect the Wires First (Inside the Radiosonde).

NOTE: *In step p. (and Figure N-14), it is important to connect the ground on the radiosonde to the ground on the battery first. This is necessary for proper microprocessor start-up.*

- q. Tuck excess wire and the connector on the top or side of the battery inside the battery compartment (See Figure N-15).



Figure N-15 – Battery in Compartment

NOTE: *Failure to put all the battery wire inside the battery compartment may cause radio energy to feed back into the circuits of the radiosonde.*

- r. Close the flap over the battery compartment and tape it shut with the provided tape strips and masking tape used to pack the radiosonde inside its plastic bag.

- s. Apply the Station Information Label to the side of the radiosonde above the Channel Select Wires flap. This label is intended to eliminate the need for the observer to open the Return Mail Bag flap. The mail bag is extremely difficult to remove and replace (See Figures N-16 and N-17).

HARMLESS WEATHER INSTRUMENT

RELEASED BY THE NOAA NATIONAL WEATHER SERVICE FROM:

_____ on _____ and _____

Station Location (City, State) Date Time (UTC)

Please return this radiosonde instrument to the National Weather Service using the self-addressed prepaid mailbag provided under the perforated, removable side tab.

Figure N-16 – Station Information Label



Figure N-17 – Label on Radiosonde

- t. Place the radiosonde on the baseline stand, a styrofoam box or suspend and turn on the GPS repeater. Leave the battery connected to the radiosonde for a minimum of 5 minutes prior to beginning baseline (See Figures N-18 and N-19).

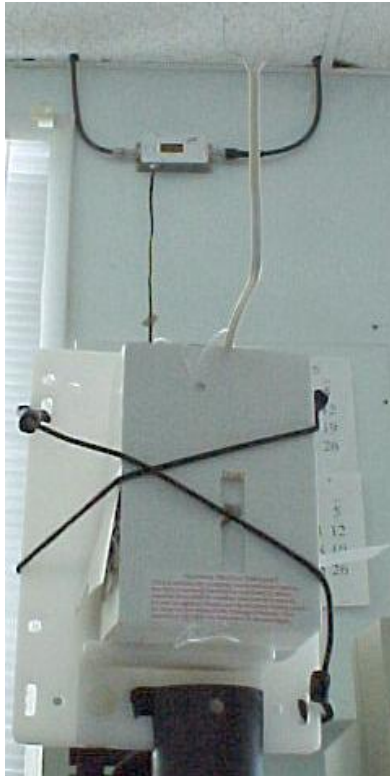

Figure N-18 – Baseline Stand

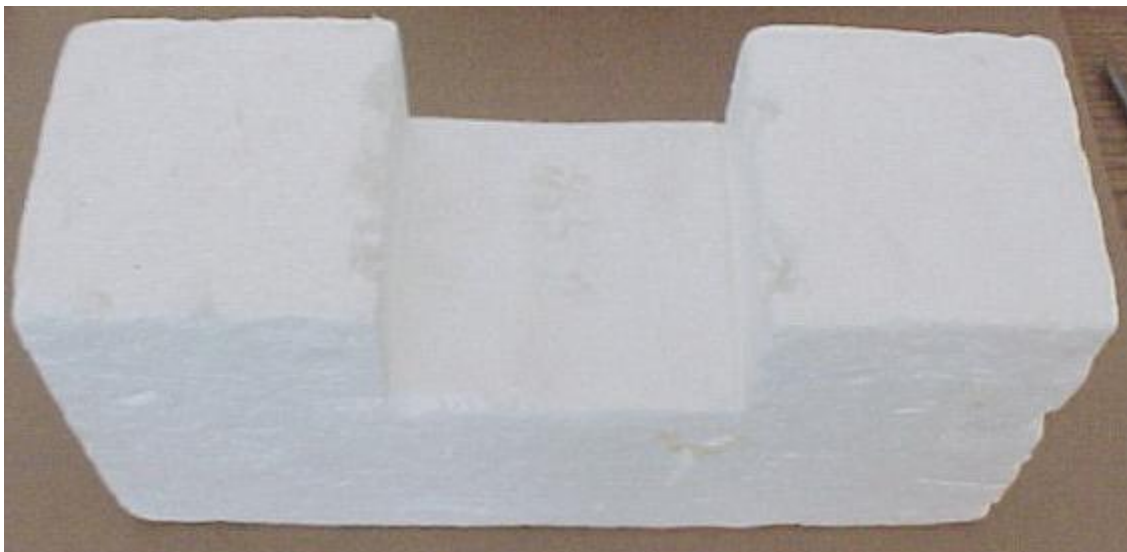

Figure N-19 – Styrofoam Block

NOTE: *The MkIIA requires a minimum of 5.6 volts to activate properly. Waiting 5 minutes in Step t. is necessary to bring the battery up to the proper voltage and ensure the radiosondes circuitry is also warmed up.*

- u. After waiting a minimum of 5 minutes, ensure the tracking equipment is set to the same frequency as the radiosonde and check signal strength.

CAUTION: *For a 2nd or 3rd release - Select another frequency - Do not use the "Scan" function to ensure calibration data from the other radiosonde is not used at baseline.*

- v. After ensuring a good strong signal, at least 60 on the Antenna/TRS Display, begin Baseline. If the PTU data or GPS is not received, disconnect the battery from the radiosonde (Disconnect the Positive or Red wire first). Wait 30 seconds then reconnect and restart baseline. This should always be attempted prior to rejecting the radiosonde.

NOTE: *The radiosonde starts acquiring satellites once the battery is connected. Nominal GPS acquisition and lock-on times are approximately 2 minutes.*

- w. After the baseline has been completed, the workstation will indicate the radiosonde is ready to be launched. The GPS Status Window should indicate that the radiosonde has achieved lock-on with at least four satellites and the SPS is able to compute position and velocity data for the radiosonde. The workstation will also display pressure, temperature, and humidity data at the bottom of the screen. Verify the status bar is receiving the pressure, temperature, and relative humidity (PTU) data. Point the antenna in the direction the balloon is expected to travel and place the antenna in manual before leaving the office.
- x. At the inflation shelter, attach the radiosonde to the balloon train assembly.
- y. Ensure the CDU has a good signal and the antenna can be moved. If the antenna has gone into overload, hold a slew key for "4" seconds to reactivate the motors. The motors will come back in the manual mode.
- z. Prior to release, ensure the radiosonde has had a minimum of 20 seconds to reacquire the satellites if it was taken inside the inflation building.

NOTE: *The observer will not place the radiosonde on the ground or in contact with solid objects. Doing so will cause GPS lock to be lost and could cause electrical noise or feedback that could adversely affect the signal being received.*

- aa. Carefully release the balloon train, taking care not to damage the thermistor during the release. The instrument should be held at the tie point above the top of the radiosonde.

NOTE: *Do not hold the radiosonde at the top or bottom; doing so may adversely affect*

the performance of the GPS antenna (top) and transmitter (bottom).

- bb. When returning to the office, use the Antenna/TRS Display to place the antenna in the “Search” mode. If GPS is being received, the antenna will move to the last known GPS location. If GPS is not received move the antenna manually to the direction the balloon is traveling and select “Search”. The antenna will start with a “Limited Search” pattern. If the Search pattern goes into “Full Search”, with the antenna elevation going to 90 degrees, stop the “Search” and manually reposition the antenna and begin the “Limited Search” again.

NOTE: *If a radiosonde is rejected, immediately replace the hygristor cap on the instrument, replace the sleeve over the temperature sensor, and place it back into the radiosonde package. Fill in the WS Form H-6 for Defective Radiosonde and Batteries. It should be re-inspected by the next observer to re-verify the problem still exists.*

**APPENDIX O - RULES for DISPOSAL of RADIOSONDE
BATTERY ACTIVATION in WATER**

<u>Table of Contents:</u>	<u>Page</u>
1. Introduction.....	O-1
2. Disposal of Activation Water	O-1
2.1 Sanitary Sewer Options	O-2
2.2 Septic System Options	O-2
2.3 Ground Options.....	O-2
2.4 Store Safely.....	O-2
3. Disposal of Unused Batteries.....	O-3
4. Applicable Constraints.....	O-3

Figures

O-1 Label for Activation Water Container	O-3
O-2 Label for Battery Container	O-3

1. Introduction. The following instructions will be followed for all NWS upper-air sites using radiosondes powered by water-activated batteries. WSH environmental/safety personnel arranged for analytical testing of Vaisala and Lockheed Martin Sippican batteries and activation water by the ARTECH Laboratory in Chantilly, VA. Three batteries of each manufacturer (Lockheed Martin Sippican and Vaisala) were exhausted prior to delivery to the laboratory. Approximately half a gallon of tap water was used for activation of each battery.

The Toxic Characteristic Leaching Procedure (TCLP) was performed to determine the appropriate classification of waste. The activation water was tested for pH and copper. Additionally, to replicate some field operational conditions, extended soaks of Lockheed Martin Sippican and Vaisala were analyzed.

The disposal recommendations apply to all soak types. The TCLP demonstrated that batteries can be characterized as a non-hazardous waste as defined by the Resource Conservation and Recovery Act. The analytical results for chemical tests have been placed on a spreadsheet and compared to applicable regulatory standards. The spread sheet is located on the EASC Environmental Web under Radiosondes. Copies of certified lab results may be obtained from the Regional Environmental Compliance Officers (RECO's).

2. Disposal of Activation Water. These are the rules on how to dispose of battery activation water:

2.1 Sanitary Sewer Options. **Consult the POTW** (Publicly Owned Treatment Works) - If the facility wastewater is being discharged to the local POTW, the Department of Public Works-POTW is consulted to verify that draining of activation water to the local sewer system is acceptable. The water should be discharged after each battery soak with POTW permission. The lab results for pH and Copper for one soak are available on the web:

<http://www.easc.noaa.gov/enviro/Radiosonde/RADIOSONDEINFO.htm><http://www.easc.noaa.gov/enviro/Radiosonde/RADIOSONDEINFO.htm>

If discharge to POTW is not permitted, proceed with soaking water collection as described in paragraph 2.2.b.

- a. Obtain a written record - The consultation and permission is obtained in writing and the documentation kept with the environmental files at the Facility. The laboratory results on the web can be used to assist in this consultation.
- b. Pour down the drain.
- c. When using a toilet- lift the toilet seat lid and pour close to the water level. Flush two times.
- d. When pouring down the sink, pour into the sink drain hole and run the tap water for one minute. Wipe the sink with a paper towel.

2.2 Septic System Options. Disposal into a septic system is not permissible.

- a. Collection - If a septic system is used on site, then the water is collected in a jug for off site disposal.
- b. Offsite disposal - Coordinate with the closest municipal POTW for delivery and pouring into their system at an alternate location; or disposal through a local contractor. Collection frequency should be established by coordinating with the local POTW or disposal company. Lab results for pH and Copper for 14, 28 and 42 soaks are available on the web site:

<http://www.easc.noaa.gov/enviro/Radiosonde/RADIOSONDEINFO.htm>

- c. Minimize waste water - In the future, the NWS may scientifically validate the switch to alkaline or other types of batteries, which are not water activated.

2.3 Ground Options. Ground dumping of waste is not permitted by NOAA.

2.4 Store Safely. Until disposal, maintain the activation water in a labeled container, with a screw-on lid, placed in a secure spot away from personnel activities and computers.

Radiosonde Battery _____ (name of Battery Type)	
Activation Soak Water: contains copper	
Disposal to approved facility	
POC _____	Date _____

Figure O-1 – Label for Activation Water Container

3. Disposal of Unused Batteries. Batteries which are no longer needed are managed as Hazardous or Universal Waste. The batteries cannot accumulate or be tossed into the Station dumpster. Collect batteries in a bucket or plastic pail. Mark the Container as indicated in Figure O-2. Store the container in a safe, secure place. Document your accumulation, storage and disposal in a log or in your red Environmental Compliance notebook. File copies of disposal receipts and shipment documents. Required training of the staff can be accomplished by notice or e-mail on the existence of your battery collection program and process.

Batteries for Recycling	
Must be disposed of in One Year	
POC _____	
Date _____	

Figure O-2 – Label for Battery Container

4. Applicable Constraints. The consistency of procedures used to activate radiosonde batteries is very important. Activation of batteries will be performed in accordance with manufacturers’ instructions. The test results are based on a single battery soaked in approximately ½ a gallon or multiple batteries soaked in approximately one quart of tap water.

Using less than ½ gallon of water for a single soak (when discharge to local POTW) and one quart for multiple soaks (when collected for disposal off site) would alter copper and pH values listed in the Excel spreadsheet.

Further assistance with selection of an appropriate activation water disposal procedure can be requested from NOAA Regional Environmental Compliance Officers (RECO’s), NWS Regional Environmental Safety Coordinator, or WSH environmental/safety compliance staff.

APPENDIX P - ACRONYMS and ABBREVIATIONS

AC	Alternating Current
AFC	Automatic Frequency Control
AM	Amplitude Modulation
ART	Automatic Radio Theodolite
ART-1	GMD
ART-2	WBRT
ARCTIC	Automatic Radio Theodolite Interface Card
ASN	Agency Stock Number
AWIPS	Advanced Weather Interactive Processing System
BILS	Balloon Inflation Launch Shelter
CCW	Counter Clockwise
CDU	Control Display Unit
COTS	Commercial-Off-The-Shelf
CPU	Central Processing Unit
CW	Clockwise
Db	Decibels
DC	Dry Charge
DCE	Digital Communication Equipment
EEPROM	Electrically Erasable Programmable Read-Only Memory
EHB	Engineering Handbook
EMRS	Engineering Management Reporting System
FAA	Federal Aviation Administration
FM	Frequency Modulation
FMH	Federal Meteorological Handbook
GMD	Ground Meteorological Device
GPH	Geopotential Height
GPS	Global Positioning Satellite
hPa	Hecto Pascals
IDD	Interface Design Description
IF	Intermediate Frequency
IR	Infrared Radiation
KBPS	Kilobites Per Second
KHz	Kilohertz
LCD	Liquid Crystal Display
LED	Light Emitting Diode
LORAN	Long Range Navigation
LOS	Loss of Signal
LOS	Line-of-Sight
LRU	Line/Lowest Replaceable Unit
Mb	Millibar
MCU	Master Control Unit -RDF
MCU	Motion Control Unit-RRS
MET	Meteorological

MHz	Megahertz
MOA	Memorandum of Agreement
Mph	Miles Per Hour
MSL	Mean Sea Level
NAVAID	Navigational Aid
NCDC	National Climatic Data Center
NCEP	National Centers for Environmental Prediction
NEC	National Electrical Code
NFPA	National Fire Protection Association
NLSC	National Logistics Support Center
Nm	Nautical Mile
NOAA	National Oceanic Atmospheric Administration
NOTAM	Notice to Airman
NRC	National Reconditioning Center
NWS	National Weather Service
PDB	Precision Digital Barometer
PSI	Pounds Per Square Inch
PTU	Pressure, Temperature, Humidity
QC	Quality Control
R/ACU	Receiver/Antenna Control Unit
RADAT	Radiosonde Observation Data
RAM	Random Access Memory
RCU	Remote Control Unit
RDF	Radio Direction Finding
RF	Radio Frequency
RH	Relative Humidity
RH	Regional Headquarters
ROM	Read Only Memory
RMS	Route Mean Square
RPU	Remote Processing Unit
RRS	Radiosonde Replacement System
RSOIS	Radiosonde Surface Observing Instrument System
RTP	Reimbursable Task Plan
RWS	RRS Work Station
SCA	System Communication Assemblies
SDL	System Data Logger
SDM	Senior Duty Meteorologist
SDM	Station Duty Manual
SID	Station Identifier
SPS	Signal Processing System
SPU-11	Signal Processing Unit -11
TLCP	Toxic Characteristic Leaching Procedure
TRS	Telemetry Receiving System
UHF	Ultra High Frequency
UPS	Uninterruptible Power Source
UTC	Universal Time Code

