

Optimira Energy, Inc.

formerly

Cinergy Solutions

...providing total energy solutions



Utilizing a partnership approach with customers



- ★ Projects under contract
- X Projects under LOI/MOU
- ZAPCO Projects

Projects:

- | | |
|---------------------------------|---------------------------|
| Celanese Rock Hill, | Celanese Narrows |
| BP Texas City, | Equistar Tuscola, |
| P&G Cincinnati, | Kodak Rochester, |
| GM Shreveport, | Millennium Ashtabula, |
| Blue Lake, | GM Oklahoma City, |
| Lafarge, | St. Paul District Energy, |
| Cincinnati Cooling, | GM Lansing, |
| Orlando Cooling, | GM Delta Township, |
| Philadelphia Naval Base, | |
| US Energy Biogas (28 projects) | |



First steps in Energy Studies

- Organizational commitment to the initiative.
(Senior Management to plant operators)
- Pre-determined payback period / rate of return.
- Internal Funding or 3rd party funding.
- Understanding of utility costs and tariff structure.
- Internal or external implementation.

Determination of Resources

Option 1

Implement energy improvement internally

Advantages

- Utilization of internal resources
- Complete Control of Process

Disadvantages

- Distracts Focus from core business
- May lack total energy expertise
- Speed of implementation
- Assume full financial risk

Option 2

Hire an Engineer to design and a Contractor to implement

Advantages

- Control of Process
- Competitive bid situation
- Expertise at installation

Disadvantages

- Lack of ingenuity in solution development
- Still need to provide project management
- Assume full cost & savings risk

Option 3

Team with a 3rd party to develop and implement energy improvements

Advantages

- Allow focus on core business
- Access to all areas of energy expertise
- Greatest cost reduction
- Reduced implementation time
- Process consistency and standardization
- Outsource cost and savings risk

Disadvantages

- Some resource allocation is required to develop joint plan
- Small price premium
- Risk in selecting the right partner

Feasibility Study Process

- 2 - 3 day analysis to review energy consumption.
- Areas of Focus:
 - Compressed Air
 - Steam
 - Waste Heat Sources
 - HVAC
 - Lighting
 - Alternate Fuel Capabilities
- Develop Site Energy Balance

Study Results

- Project list with calculated energy savings and IRR.
- Understanding of:
 - Overall Project
 - Cost & Savings Risk
 - Impact on Overall Utility System
 - Capital Requirement
 - Installation Cost
- Determination of implementation team.
- Breakdown of utility consumption of the primary and secondary utilities.

ANNUALIZED ENERGY UTILIZATION

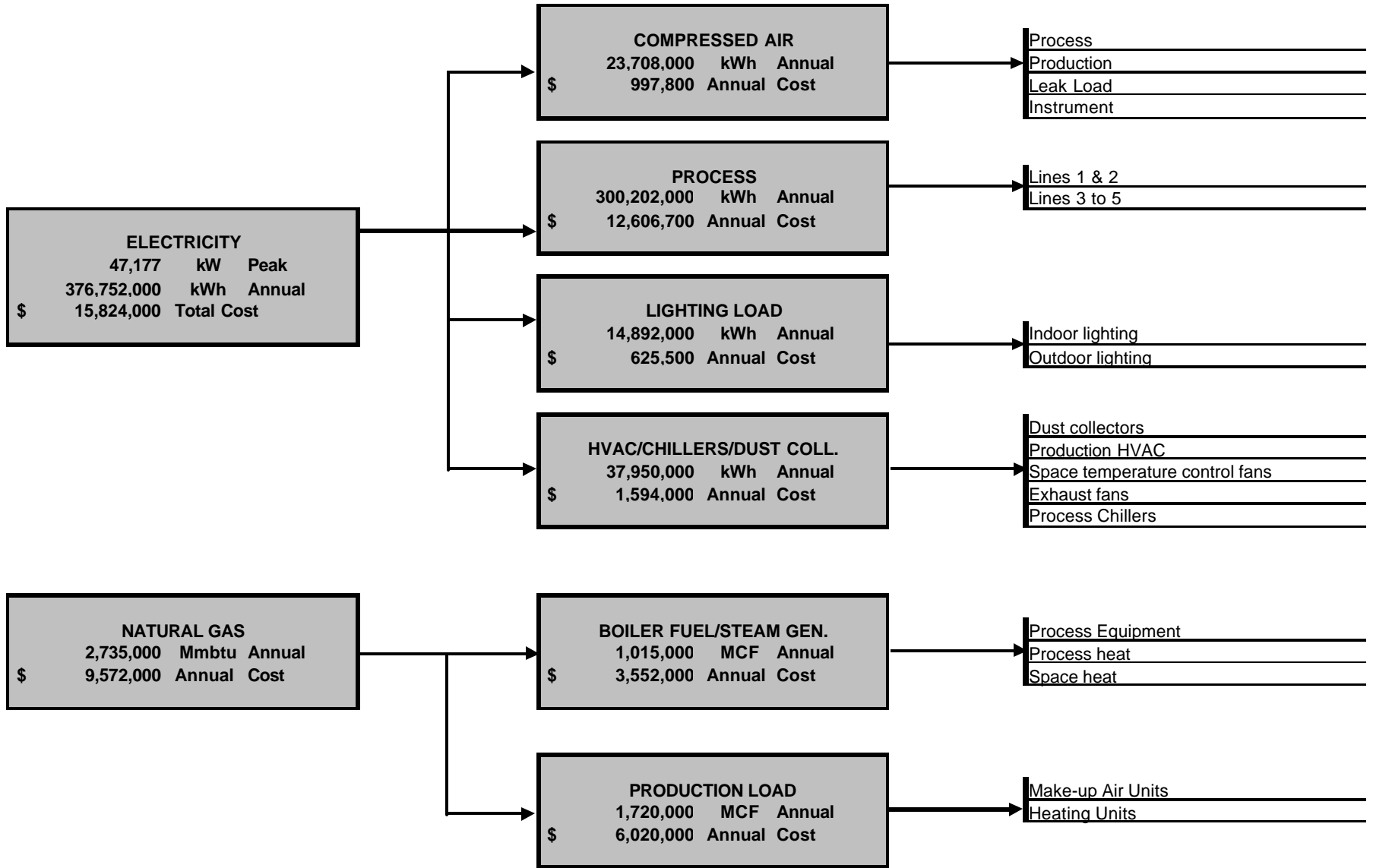

PROJECT LIST

ECM No.	Project Description	Savings Type	Potential Energy Savings	Estimated Project Cost	Potential Payback (Years)	Devel'mt Cost	Comments
Projects with 2.7 or Better Payback							
1.1	Install a new inlet filtration system on gas turbine.	Electricity	\$426,100	\$802,676	1.88	\$20,000	Utility Rate = .045/kwh
1.3	Turbine Inlet Fuel Preheating	Natural Gas	\$276,080	\$662,818	2.40	\$20,000	
2.4	Supervisory chilled water plant controls	Electricity	\$134,054	\$354,767	2.65	\$10,000	
3.1	Preheat boiler plant mill water with white water downstream of flotation unit	Fuel	\$92,944	\$225,575	2.43	\$11,500	
3.4	Compressed Air Retrofit	Electricity	\$320,150	\$890,000	2.78	\$27,500	Utility Rate = .045/kwh
5.6	Install a boiler blow down heat recovery makeup water heat exchanger.	Natural Gas	\$27,266	\$71,404	2.62	\$8,000	
5.8	Improvement in Wastewater System	Waste Removal	\$450,000	\$913,750	2.03	\$15,000	
5.10	Install a feed water economizer on boiler #4	Electricity	\$143,475	\$225,484	1.57	\$9,500	
7.1	Lighting Retrofit	Electricity	\$750,734	\$2,006,000	2.67	\$27,500	Utility Rate = .045/kwh
TOTALS:			\$2,620,803	\$6,152,474	2.35	\$149,000	

Project Implementation

Specific Project Opportunity

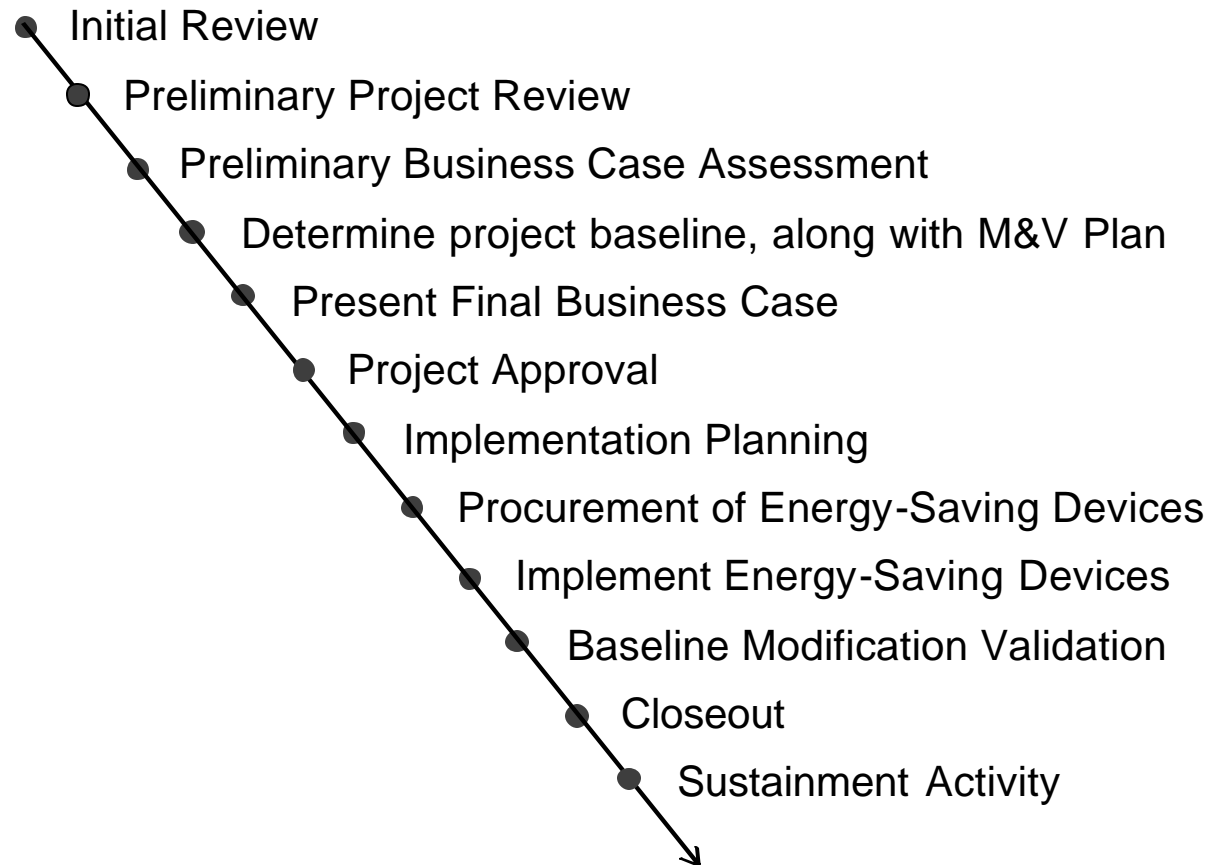



Compressed Air Project Objective

Objective

Reduce on-line compressed air horsepower by stabilizing the plant air at a lower pressure, configuring efficient compressed air arrangement and reducing demand-side usage via process retrofits to point of use.

Rational

Current operating profile indicated that excess compressor horsepower was on-line to accommodate varying production requirements. The supply system had limited configuration capabilities preventing optimum economic arrangement. The plant consisted of demand side users that would be more efficient by utilizing other energy sources than compressed air. Modifications allowed reduced base demand offering increased reserve capacity and energy savings.



System prior to Retro-fit

Subaru Compressed Air Supply Equipment Architecture

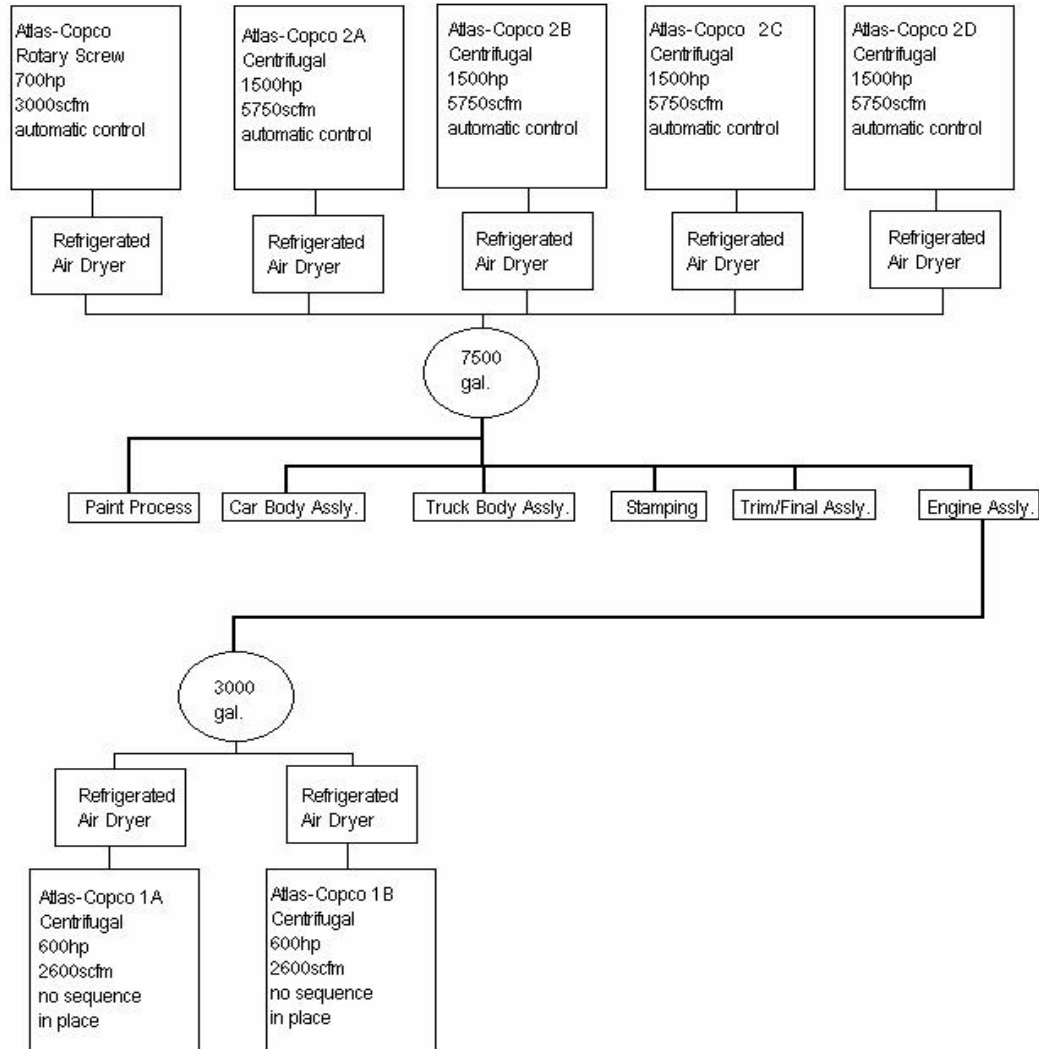



System after Retro-fit

Subaru Compressed Air Supply Layout With
Flow Control-Valve. no scale, flow only.

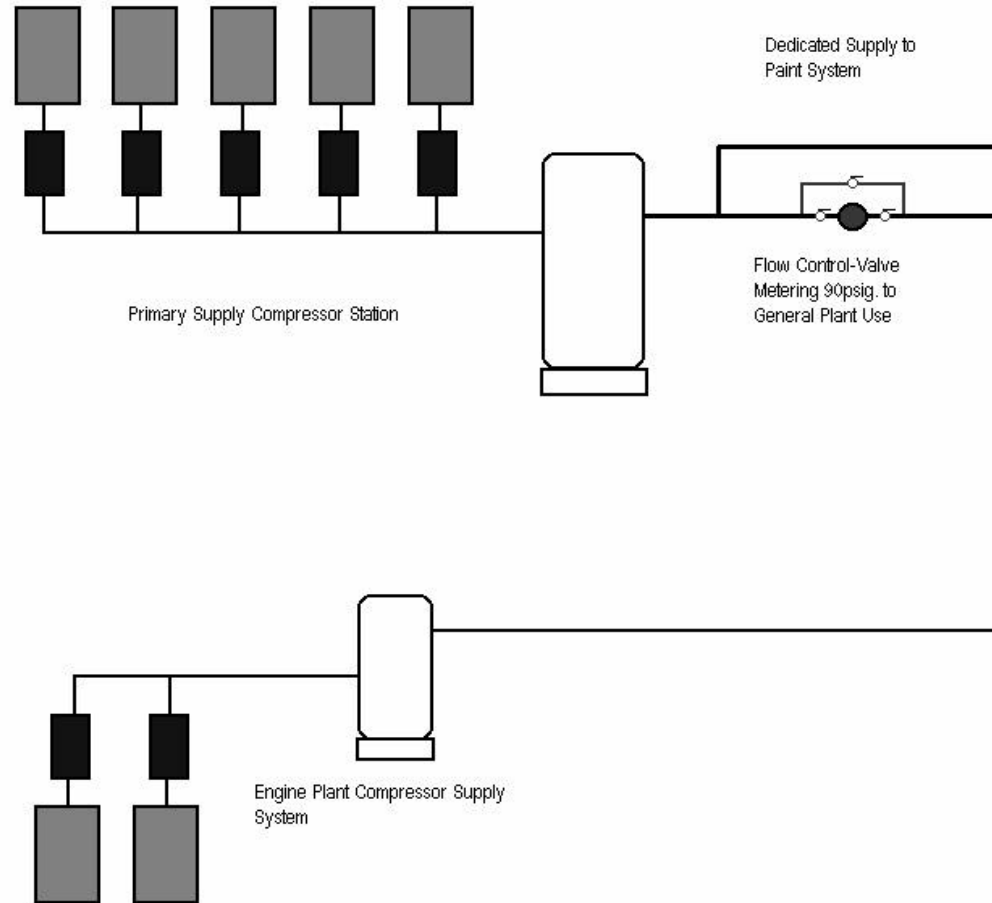



Project Financials

Energy Savings

\$88,965 or 2,120,625 kWh / year

11.6% reduction in the compressed air system

Investment

\$237,194

Financial Return

2.7-year simple payback

Other Benefits

Reduced maintenance due to reduced run time, increased compressor life, and improved reliability

Sample list of Clients

GOVERNMENT

- Cincinnati Water Works – Cincinnati, OH
- Cincinnati Metropolitan HA – Cincinnati, OH
- Crane Naval Base – Crane, IN
- Dayton Metropolitan HA – Dayton, OH
- Butler Metropolitan HA – Middletown, OH
- LaSalle Metropolitan HA – Ottawa, IL
- City of Niagara Falls – Niagara Falls, NY
- Terra Haute HA – Terra Haute, IN
- City of Terra Haute – Terra Haute, IN

HEALTHCARE

- Meadville Medical Center – Meadville, PA
- Greene County Memorial Hospital – Waynesburg, PA
- Clay County Hospital – Brazil, IN

EDUCATION

- Allegheny College – Meadville, PA
- Great Oaks Vocational Schools – Cincinnati, OH
- Ohio University – Athens, OH
- Glasgow Schools, Glasgow, KY
- New Albany Schools, New Albany, IN
- Rose Hulman Institute for Technology – Terre Haute, IN
- Hanover College - IN

INDUSTRIAL

- Coca Cola – Cincinnati, OH
- Duramed Pharmaceuticals – Pleasant Ridge, OH
- Eastman Kodak
- Equistar Chemicals
- Essex Group, Inc. – Sikeston, MO
- Fleetguard, Inc. (Cummins) – Cookeville, TN
- Formica – Cincinnati, OH
- General Motors – Bedford, IN
- General Motors Worldwide Facilities Group
- Heartland Steel – Terre Haute, IN
- Hopple Plastics – Cincinnati, OH
- Instat Precision – Rushville, IN
- Kobelco
- Lafarge – Silver Grove, KY
- Millennium Inorganic Chemicals – Ashtabula, OH
- Millennium Inorganic Chemicals – Hawkins Point, OH
- Miller Brewing Company – Trenton, OH
- Procter & Gamble – Cincinnati, OH
- Procter & Gamble – Cape Girardeau, MO
- Rae Magnet – Lafayette, IN
- Schwans Foods (SSE Manufacturing) – Florence, KY
- Subaru Automotive – Lafayette, IN
- Worthington Steel – Monroe, OH

CONTACT INFORMATION

Doug Woodward

Cinergy Solutions

6512 Westwood Drive

Charlestown, IN 47111

(812) 246-9766 – Phone

Doug.woodward@cinergy.com