

# **Bureau of Indian Affairs**

**Office of Facilities Management and Construction**



## **JUSTICE / DETENTION FACILITIES DESIGN HANDBOOK**

**June 30, 2011**

**TABLE OF CONTENTS**

**1. GENERAL INFORMATION**

**GENERAL ..... 1000-1**

**USING THE BIA HANDBOOK AND SPACE TEMPLATES ..... 1010-1**

**JUSTICE / DETENTION FACILITY DESIGN PHILOSOPHY ..... 1020-1**

**CULTURAL DESIGN PHILOSOPHY ..... 1030-1**

**CODES, STANDARDS, AND LAWS ..... 1040-1**

**ABBREVIATIONS ..... 1050-1**

**2. PRESENTATION OF DATA**

**GENERAL ..... 2000-1**

**CONSULTANT SUBMITTAL REQUIREMENTS ..... 2010-1**

**DOCUMENT REVIEW AND COORDINATION ..... 2020-1**

**DESIGN ANALYSIS ..... 2030-1**

**DRAWINGS ..... 2040-1**

**SPECIFICATIONS ..... 2050-1**

**COST ESTIMATING ..... 2060-1**

**3. LEED GOALS AND GUIDELINES**

**GENERAL ..... 3000-1**

**BIA OBJECTIVES AND REQUIREMENTS ..... 3010-1**

**LEED-NC GREEN BUILDING RATING SYSTEM ..... 3020-1**

**4. SITE DESIGN**

**GENERAL ..... 4000-1**

**CODES, STANDARDS, AND LAWS ..... 4010-1**

**SITE DESIGN PRINCIPLES AND CONCEPTS ..... 4020-1**

**VEHICULAR CIRCULATION ..... 4030-1**

**EMERGENCY ACCESS AND CIRCULATION ..... 4040-1**

**SERVICE AREAS ..... 4050-1**

**HARDSCAPE AREAS ..... 4060-1**

**FENCING ..... 4070-1**

**GEOTECHNICAL EVALUATION ..... 4080-1**

|           |   |        |
|-----------|---|--------|
| <b>5.</b> | <b>CIVIL</b>  |        |
|           | GENERAL .....                                       | 5000-1 |
|           | CIVIL SELECTION CRITERIA .....                      | 5010-1 |
|           | CODES, STANDARDS, AND LAWS .....                    | 5020-1 |
|           | SITE DESIGN AND EARTHWORK.....                      | 5030-1 |
|           | EROSION CONTROL .....                               | 5040-1 |
|           | UTILITY INFRASTRUCTURE .....                        | 5050-1 |
|           | WATER SYSTEMS.....                                  | 5060-1 |
|           | WASTEWATER SYSTEMS .....                            | 5070-1 |
|           | STORM DRAINAGE .....                                | 5080-1 |
|           | ROADS.....  | 5090-1 |
|           | PAVING.....   | 5100-1 |
| <b>6.</b> | <b>LANDSCAPE DESIGN</b>                             |        |
|           | GENERAL .....                                       | 6000-1 |
|           | LANDSCAPE MATERIALS SELECTION CRITERIA.....         | 6010-1 |
|           | CODES, STANDARDS, AND LAWS .....                    | 6020-1 |
|           | LANDSCAPE AREAS .....                               | 6030-1 |
|           | WATER CONSERVATION AND IRRIGATION.....              | 6040-1 |
|           | SOIL, SOIL AMENDMENTS, AND MULCH.....               | 6050-1 |
|           | INTEGRATED WEED, DISEASE, AND PEST MANAGEMENT ..... | 6060-1 |
| <b>7.</b> | <b>ARCHITECTURAL</b>                                |        |
|           | GENERAL .....                                       | 7000-1 |
|           | ARCHITECTURAL SYSTEMS SELECTION CRITERIA.....       | 7010-1 |
|           | CODES, STANDARDS, AND LAWS .....                    | 7020-1 |
|           | MOVEABLE AND FIXED FURNITURE/EQUIPMENT .....        | 7030-1 |
|           | ACOUSTICS .....                                     | 7040-1 |
|           | EXTERIOR WALL SYSTEMS.....                          | 7050-1 |
|           | ROOFING SYSTEMS.....                                | 7060-1 |
|           | INTERIOR PARTITIONS .....                           | 7070-1 |
|           | ROOF DRAINAGE .....                                 | 7080-1 |
|           | THERMAL AND MOISTURE PROTECTION.....                | 7090-1 |
|           | GLAZING SYSTEMS.....                                | 7100-1 |
|           | DAYLIGHTING STRATEGIES .....                        | 7110-1 |
|           | DOOR SYSTEMS .....                                  | 7120-1 |
|           | SIGNAGE SYSTEMS .....                               | 7130-1 |
| <b>8.</b> | <b>INTERIORS</b>                                    |        |
|           | GENERAL .....                                       | 8000-1 |
|           | INTERIOR FINISH SYSTEMS SELECTION CRITERIA .....    | 8010-1 |
|           | CODES, STANDARDS, AND LAWS .....                    | 8020-1 |
|           | FINISHES .....                                      | 8030-1 |
|           | PUBLIC CORRIDORS .....                              | 8040-1 |

|            |   |         |
|------------|---|---------|
| <b>9.</b>  | <b>STRUCTURAL</b>                                       |         |
|            | GENERAL .....   | 9000-1  |
|            | STRUCTURAL SYSTEMS SELECTION CRITERIA .....             | 9010-1  |
|            | CODES, STANDARDS, AND LAWS .....                        | 9020-1  |
|            | STRUCTURAL SYSTEMS CONSIDERATIONS .....                 | 9030-1  |
|            | FLOOR SYSTEMS.....                                      | 9040-1  |
|            | ROOF FRAMING SYSTEMS .....                              | 9050-1  |
|            | LATERAL LOAD RESISTING SYSTEMS .....                    | 9060-1  |
|            | VERTICAL ELEMENTS .....                                 | 9070-1  |
|            | STRUCTURAL WALLS .....                                  | 9080-1  |
|            | APPURTENANCES .....                                     | 9090-1  |
| <b>10.</b> | <b>MECHANICAL</b>                                       |         |
|            | GENERAL .....   | 10000-1 |
|            | MECHANICAL SYSTEMS SELECTION CRITERIA .....             | 10010-1 |
|            | CODES, STANDARDS, AND LAWS .....                        | 10020-1 |
|            | HEATING, VENTILATION, AND AIR-CONDITIONING SYSTEMS..... | 10030-1 |
|            | TEMPERATURE CONTROL AND ENERGY MANAGEMENT SYSTEM.....   | 10040-1 |
|            | PLUMBING.....   | 10050-1 |
|            | TRAINING.....   | 10060-1 |
| <b>11.</b> | <b>ELECTRICAL</b>                                       |         |
|            | GENERAL .....   | 11000-1 |
|            | ELECTRICAL SYSTEMS SELECTION CRITERIA .....             | 11010-1 |
|            | CODES, STANDARDS, AND LAWS .....                        | 11020-1 |
|            | EXTERIOR UTILITIES .....                                | 11030-1 |
|            | ELECTRICAL SYSTEM DESIGN .....                          | 11040-1 |
|            | GROUNDING SYSTEM.....                                   | 11050-1 |
|            | INTERIOR LIGHTING SYSTEMS .....                         | 11060-1 |
|            | EXTERIOR LIGHTING SYSTEMS .....                         | 11070-1 |
|            | LIGHTING CONTROLS .....                                 | 11080-1 |
|            | SPECIAL ELECTRICAL SYSTEMS .....                        | 11090-1 |
|            | FIRE ALARM SYSTEM.....                                  | 11100-1 |
|            | EMERGENCY AND STANDBY POWER SYSTEMS.....                | 11110-1 |
|            | LIGHTNING PROTECTION.....                               | 11120-1 |
|            | COMMISSIONING .....                                     | 11130-1 |
|            | TRAINING.....   | 11140-1 |
|            | OPERATING AND MAINTENANCE MANUALS.....                  | 11150-1 |
|            | ELECTRICAL STANDARD DETAILS.....                        | 11160-1 |
| <b>12.</b> | <b>FIRE PROTECTION</b>                                  |         |
|            | GENERAL .....   | 12000-1 |
|            | FIRE PROTECTION SYSTEMS SELECTION CRITERIA.....         | 12010-1 |
|            | CODES, STANDARDS, AND LAWS .....                        | 12020-1 |
|            | SYSTEM REQUIREMENTS.....                                | 12030-1 |

|            |   |         |
|------------|---|---------|
| <b>13.</b> | <b>INFORMATION TECHNOLOGY</b>               |         |
|            | GENERAL .....                               | 13000-1 |
|            | TECHNOLOGY SYSTEMS SELECTION CRITERIA ..... | 13010-1 |
|            | CODES, STANDARDS, AND LAWS .....            | 13020-1 |
|            | COMMUNICATIONS ROOMS AND SPACES.....        | 13030-1 |
|            | COMMUNICATIONS CABLING.....                 | 13040-1 |
|            | COMMUNICATIONS PATHWAYS .....               | 13050-1 |
|            | COMMUNICATIONS GROUNDING AND BONDING .....  | 13060-1 |
|            | OUTSIDE CONNECTIVITY .....                  | 13070-1 |
|            | NETWORK/PHONE EQUIPMENT .....               | 13080-1 |
|            | LOW VOLTAGE .....                           | 13090-1 |
|            | SECURITY.....                               | 13100-1 |
|            | ROOM TECHNOLOGY SYSTEMS .....               | 13110-1 |
|            | RADIO SYSTEM .....                          | 13120-1 |
|            | 911 CALL CENTER / DISPATCH .....            | 13130-1 |
|            | TRAINING AND O&M MANUALS.....               | 13140-1 |
| <br>       |   |         |
| <b>14.</b> | <b>KITCHEN DESIGN</b>                       |         |
|            | GENERAL .....                               | 14000-1 |
|            | DESIGN CONSIDERATIONS.....                  | 14010-1 |
|            | CODES, STANDARDS, AND LAWS .....            | 14020-1 |
|            | WORK FLOW .....                             | 14030-1 |
|            | SPACE REQUIREMENTS .....                    | 14040-1 |
|            | METALWORK FABRICATION .....                 | 14050-1 |

**1000-1. Introduction**

- 1.1. To ensure that the Tribes have judicial and detention facilities that are culturally adaptive and can adequately serve their needs, the Bureau of Indian Affairs (BIA) Office of Facilities Management and Construction (OFMC) has developed the *BIA Justice/Detention Facilities Design Handbook*. This handbook provides standardized procedures for design, drawings, specifications, design analysis, cost estimates, and related support tasks for new, expanded, and renovated BIA Justice / Detention facilities.
- 1.2. As a companion to the Handbook, OFMC has also created the *BIA Justice/Detention Facilities Space Criteria* and *BIA Justice/Detention Facilities Space Templates* in two separate volumes. The Space Criteria provides the basis to quantify size of facilities and individual spaces; and define the overall needs for each tribal community. These templates provide specific functional relationships, acceptable components, and specific programmatic criteria for each space. They include diagrammatic information to illustrate spatial layout and programmatic needs for architectural, interior design, structural, HVAC, electrical, communications, fire protection, and signage requirements spaces for all BIA justice and detention facilities

**1000-2. Program Goals**

- 2.1. The BIA's primary goals for the handbook and space templates include the following:
  - Design of facilities that reflect the importance of cultural expression
  - Program facilities to serve the individual needs of tribal communities for justice and detention services throughout the United States.
  - Sustainable design, through incorporation of the U.S. Green Building Council's LEED program, with the requirement of LEED Silver certification for all projects
  - Standardization of individual spaces and programmatic requirements without dictating building aesthetics

**1000-3. Program Overview**

- 3.1. The BIA is responsible for providing facilities to support judicial and detention programs and services for tribal communities.
- 3.2. In order to meet this goal in a cost-efficient manner, and to ensure equality for all new judicial and detention facilities, the BIA seeks to standardize the design and construction of its justice and detention facilities while still allowing for individual needs and cultural expression. Following are the specific standardization goals of the BIA, and the ways they have been addressed in this handbook and the space criteria/templates:

- 3.2.1. *The Design Process.*** To ensure a consistent design process from project to project, procedures are carefully spelled out in the Guidelines for use during design phases. These guidelines include requirements for project submittals, drawings, and specifications including content and format.
- 3.2.2. *Programmatic Areas.*** Standardized space templates of individual programmatic areas are provided to control design costs. The templates also ensure consistency without unduly limiting the design team's creativity for overall layout and design of justice and detention facilities. Relationship diagrams are provided to indicate the overall organization of justice/detention facilities and areas within it.
- 3.2.3. *Construction Methods and Building Systems.*** The design team can choose from a variety of construction methods and building systems, appropriate to different regions of the country, that have received prior BIA approval. Standardization of building systems and construction options controls costs and enables the BIA to optimize maintenance procedures and requirements and the training of facilities maintenance personnel.

**1010-1. General**

- 1.1. To make best use of the handbook, space criteria and space templates, all team members should first review the three volumes and clearly understand how the documents interrelate, as well as understand general information and related sections that are specific to their design discipline. Designers of Record must coordinate their efforts and develop strategies as a team to ensure a successful project, and to achieve LEED goals required by BIA as specified in Chapter 3 of the Handbook.

**1010-2. Scope and Applicability of the Design Handbook and Space Templates**

- 2.1. Use the *Justice/Detention Facilities Design Handbook*; *Justice/Detention Facilities Space Criteria*; *Justice/Detention Space Templates* for new justice and detention facilities funded by the BIA, to include projects with tribes and tribal organizations. The scope of this handbook is limited to Tier I detention facilities. A detailed description of Tier I detention facilities are included in Chapter 1 of the *Space Criteria Handbook*.

**1010-3. Codes, Standards, and Laws**

- 3.1. Follow codes, standards, and laws identified in this handbook as they apply to individual projects. Do not substitute alternative codes and standards without special approval from the OFMC. Submit all substitution requests in writing. All approved substitutions must be in writing.

**1010-4. Conflicts, Questions, and Appeals**

- 4.1. Where conflicts or questions arise pertaining to information presented in this handbook or in the space templates, the Designer of Record is to notify the BIA Contracting Officer in writing. The BIA Contracting Officer will review questions and forward decisions to the Designer of Record.

**1010-5. Design Process**

- 5.1. This handbook provides a general process for building and site design. The companion volume provides templates for building organization based on various justice and detention facility models. Spatial relationship diagrams illustrate ways to organize justice and detention facilities but are not all-inclusive.
- 5.2. In general, design teams are required to adhere to the layouts shown in the space templates. Use alternative room arrangements where appropriate due to building geometry; however, such deviations should be limited.



**1010-6. Building and Site Systems Selection Process**

- 6.1. Optional building systems are included in guidelines to provide design team choices to so they may address unique conditions at facility location. In choosing building systems, design teams must analyze the systems relative to the specific parameters of the project, including location, material availability, costs, etc. Use systems described if guidelines do not provide options. Coordinate recommendations and selections with BIA if building systems are required that are not included in this handbook.

**1020-1. Justice / Detention Facility Design Philosophy**

- 1.1. Because the needs of each population served by the justice center and detention facility are unique, these guidelines allow for flexibility within a framework. This handbook establishes layouts and systems that can be used as needed to ensure high quality work and living environments.
- 1.2. The arrangement of the spaces, based on both functional needs and cultural expression, is left up to the design team.
- 1.3. To meet the stated goal of the BIA to create healthy and high quality environments for their justice center and detention facilities, the design handbook and space templates specify quality building materials, building systems, and physical environments. The focus on LEED goals and sustainable design supports the overall goal for high-performance buildings with lower maintenance and operating costs.

**1030-1. Cultural Design Philosophy**

1.1. The BIA considers it vital to integrate cultural expression into their justice and detention facilities. The following are examples of ways that may be done:

**1.1.1. Architectural Design**

- Develop a cultural focal point for the community. In the justice center this may include a gathering area in one of the common spaces.
- Arrange the facility on the site in a way that is respectful of tribal values. This may include arranging buildings with regard to existing site features and surrounding landscapes.
- Select exterior and interior building materials with awareness of the colors and patterns that reflect tribal values, traditions, storytelling, or traditional arts and crafts.
- Use natural daylighting strategies to ensure a strong connection between earth and sky.
- Include areas for the display of artwork.
- Incorporate sustainable design strategies that acknowledge the value indigenous peoples place on their environment.

**1.1.2. Landscape Design**

- Incorporate sustainable landscape design strategies that are in harmony with the existing natural environment.

**1.1.3. Civil Design**

- Integrate the site and building design with existing topography and landforms.
- Leave existing land undisturbed as much as possible and place construction on previously disturbed land.

**1.1.4. Structural Design**

- Follow sustainable design principles.

**1.1.5. Mechanical Design**

- Follow sustainable design principles.

**1.1.6. Electrical Design**

- Reduce dependence on artificial illumination by incorporating natural daylighting throughout.
- Follow sustainable design principles.

**1040-1. General**

- 1.1. The codes, standards, and laws listed in this section are those used nationwide by the BIA for its justice/detention facilities. All BIA justice/detention facilities and related structures shall conform to versions of the codes and standards currently adopted by BIA that appear in this section.
- 1.2. Where two codes, standards, or laws are applicable to the topic under review, use the more stringent. Consult with the BIA Office of Facilities Management and Construction (OFMC) to resolve any questions or conflicts regarding application of codes and standards.
- 1.3. The BIA's Division of Safety and Risk Management (DSRM) shall have document review authority for compliance with all applicable codes, standards, and laws.
- 1.4. The DSRM or its authorized representative is to inspect the facility after construction to verify that it meets applicable codes and standards.

**1040-2. Applicable Codes and Standards**

- 2.1. Comply with the latest "Applicable Federal Health and Safety Codes" adopted by the Bureau of Indian Affairs, Office of Facilities Management & Construction for the design and construction of all BIA Justice and Detention facilities. Comply with the latest revision of referenced codes and standards. Design and construction may be impacted at any time when revisions are made to the "Applicable Federal Health and Safety Codes" by BIA/OFMC or when referenced codes and standards are revised.
- 2.2. Electronic file of the BIA/OFMC "Applicable Federal Health and Safety Codes" is available at their website:  
[OFMC\DPPI-Share\Codes & Standards\091008 Applicable Codes and Standards.](#)
- 2.3. American Correctional Association (ACA) Standards were used as a reference in the development of this handbook. When using this handbook for the development of a BIA Justice / Detention project refer to the most current ACA Standards publication for updates in requirements that may apply to BIA facilities.

**1050-1.Abbreviations**

1.1. The following abbreviations for names and terms are used in this handbook.

|        |  |
|--------|--|
| AAMA   | American Architectural Manufacturers Association   |
| AASHTO | American Association of State Highway and Transportation Officials                               |
| ABA    | Architectural Barriers Act   |
| ABAAG  | Architectural Barriers Act Accessibility Guidelines  |
| ACA    | American Correctional Association  |
| ACI    | American Concrete Institute  |
| ADA    | Americans with Disabilities Act  |
| ADAAG  | Americans with Disabilities Act Accessibility Guidelines for Buildings and Facilities            |
| AFF    | above finished floor   |
| AGA    | American Gas Association   |
| AHU    | air handling unit  |
| AIC    | amps interrupting capacity   |
| AISC   | American Institute of Steel Construction   |
| AISI   | American Iron and Steel Institute  |
| ANLA   | American Nursery & Landscape Association (formerly the American Association of Nurserymen [AAN]) |
| ANLA   | American Standard for Nursery Stock (by the American Nursery & Landscape Association)            |
| ANSI   | American National Standards Institute  |
| ARI    | Air-Conditioning and Refrigeration Institute   |
| ASCE   | American Society of Civil Engineers  |
| ASHRAE | American Society of Heating, Refrigerating and Air-Conditioning Engineers                        |
| ASME   | American Society of Mechanical Engineers   |
| ASSE   | American Society of Sanitary Engineering   |
| ASTM   | American Society for Testing and Materials   |

|                  |   |
|------------------|---|
| ATC              | Applied Technology Council                  |
| ATS              | automatic transfer switch                   |
| A/V              | audiovisual                                 |
| AWI              | Architectural Woodwork Institute            |
| AWS              | American Welding Society                    |
| AWWA             | American Water Works Association            |
| BHMA             | Builders Hardware Manufacturers Association |
| BIA              | Bureau of Indian Affairs                    |
| BMP              | best management practice                    |
| BOD <sub>5</sub> | biochemical oxygen demand (5-day)           |
| BMS              | building management system                  |
| CADD             | Computer-Aided Design and Drafting          |
| CFI              | Contractor to Furnish and Install           |
| CFC              | chlorofluorocarbon                          |
| CFR              | Code of Federal Regulations                 |
| CGA              | Compressed Gas Association                  |
| CMU              | concrete masonry unit                       |
| CPSC             | U.S. Consumer Product Safety Commission     |
| CRI              | color rendering index                       |
| CSI              | Construction Specifications Institute       |
| CT               | current transformer                         |
| DCV              | demand-controlled ventilation               |
| DDC              | direct digital control                      |
| DHW              | domestic hot water                          |
| DIP              | ductile iron pipe                           |
| DSRM             | Division of Safety and Risk Management      |
| DL               | distance learning                           |
| DOE              | U.S. Department of Energy                   |
| DX               | direct expansion                            |

---

|        |  |
|--------|--|
| EEPROM | electrically erasable programmable read-only memory            |
| EMS    | Environmental Management Systems                               |
| EPA    | U.S. Environmental Protection Agency                           |
| EPROM  | erasable programmable read-only memory                         |
| ESC    | erosion and sedimentation control                              |
| ETS    | environmental tobacco smoke                                    |
| FACP   | fire alarm control panel                                       |
| FCC    | Federal Communications Commission                              |
| FDC    | fire department connection                                     |
| FEMA   | Federal Emergency Management Agency                            |
| FHWA   | Federal Highway Administration                                 |
| FIRM   | Flood Insurance Rate Map                                       |
| FM     | Factory Mutual   |
| FPE    | fire protection engineer                                       |
| FSC    | Forest Stewardship Council                                     |
| FSTC   | field sound transmission class                                 |
| GFCI   | ground fault circuit interrupter                               |
| HCFC   | hydrochlorofluorocarbon  |
| H-O-A  | hand-off-auto  |
| HVAC   | heating, ventilation, and air-conditioning                     |
| IAM    | <i>Indian Affairs Manual</i>                                   |
| IAMPO  | International Association of Plumbing and Mechanical Officials |
| IAQ    | indoor air quality   |
| IBC    | International Building Code                                    |
| ICEA   | Insulated Cable Engineers Association                          |
| IDF    | intensity-duration-frequency                                   |
| IEEE   | Institute of Electrical and Electronics Engineers              |
| IESNA  | Illuminating Engineering Society of North America              |
| IGSHPA | International Ground Source Heat Pump Association              |

|         |   |
|---------|---|
| IIC     | impact insulation class   |
| IMC     | International Mechanical Code   |
| IP      | Internet Protocol   |
| IPC     | International Plumbing Code   |
| IPM     | integrated pest management  |
| IPMVP   | International Performance Measurement & Verification Protocol             |
| IT      | information technology  |
| KEE     | ketone ethylene ester   |
| LCCA    | Life-Cycle Cost Analysis  |
| LEED    | Leadership in Energy and Environmental Design                             |
| LEED AP | LEED Accredited Professional  |
| LEED-NC | Leadership in Energy and Environmental Design<br>New Construction program |
| LPG     | liquefied petroleum gas   |
| LPI     | Lightning Protection Institute  |
| LTAR    | long-term acceptance rate   |
| M&V     | measurement and verification  |
| MBMA    | Metal Building Manufacturers Association                                  |
| MCC     | motor control center  |
| MDP     | main distribution panel   |
| MERV    | Minimum Efficiency Reporting Value  |
| MIC     | microbiologically influenced corrosion                                    |
| MSE     | mechanically stabilized earth   |
| NC      | noise criterion   |
| NEBB    | National Environmental Balancing Bureau                                   |
| NEC     | National Electrical Code  |
| NECA    | National Electrical Contractors Association                               |
| NEMA    | National Electrical Manufacturers Association                             |
| NETA    | InterNational Electrical Testing Association                              |



---

|       |  |
|-------|--|
| NFC   | National Fire Code                               |
| NFPA  | National Fire Protection Association             |
| NGRS  | National Geodetic Reference System               |
| NIST  | National Institute of Standards and Technology   |
| NOAA  | National Oceanic & Atmospheric Administration    |
| NPDES | National Pollutant Discharge Elimination System  |
| NPSH  | net positive suction head                        |
| NPT   | National Pipe Thread                             |
| NRC   | noise reduction coefficient                      |
| NSF   | National Sanitation Foundation                   |
| NSFPE | National Society of Fire Protection Engineers    |
| O&M   | operations and maintenance                       |
| OFI   | Owner to Furnish and Install                     |
| OFCI  | Owner to Furnish, Contractor to Install          |
| OFMC  | Office of Facilities Management and Construction |
| OSB   | oriented-strand board                            |
| OSHA  | Occupational Safety & Health Administration      |
| OSP   | outside plant                                    |
| PA    | public address                                   |
| PCB   | polychlorinated biphenyl                         |
| PE    | professional engineer                            |
| PHS   | U.S. Public Health Service                       |
| PoE   | Power over Ethernet                              |
| POR   | Program of Requirements                          |
| PTZ   | pan-tilt-zoom                                    |
| PVC   | polyvinyl chloride                               |
| QRAS  | quick-response automatic sprinkler               |
| RAM   | random-access memory                             |
| RCDD  | registered communications distribution designer  |

|        |  |
|--------|--|
| RCP    | reinforced concrete pipe   |
| RSES   | Refrigeration Service Engineers Society                            |
| SDI    | Steel Door Institute   |
| SMACNA | Sheet Metal and Air Conditioning Contractors' National Association |
| SRI    | solar reflectance index  |
| SSPC   | Society for Protective Coatings                                    |
| STC    | sound transmission class   |
| SWMP   | storm water management plan  |
| SWPPP  | storm water pollution prevention plan                              |
| TERO   | Tribal Employment Rights Office                                    |
| TGB    | telecommunications grounding busbar                                |
| TLCP   | Toxicity Characteristic Leaching Procedure                         |
| TMGB   | telecommunications main grounding busbar                           |
| TPO    | thermoplastic polyolefin   |
| TR     | telecommunications room  |
| TVSS   | transient voltage surge suppressor                                 |
| UFC    | <del>Unified Facilities Criteria</del>                             |
| UL     | Underwriters Laboratories  |
| UPS    | uninterruptible power supply                                       |
| USDA   | United States Department of Agriculture                            |
| USDOT  | United States Department of Transportation (USDOT)                 |
| USGBC  | U.S. Green Building Council  |
| VAV    | variable air volume  |
| VFD    | variable frequency drive   |
| VOC    | volatile organic compound  |
| WDMA   | Window & Door Manufacturers Association                            |
| WPCF   | Water Pollution Control Federation                                 |
| WWPA   | Western Wood Products Association                                  |

**2000-1. Introduction**

- 1.1. The BIA *Justice / Detention Facilities Design Handbook* establishes guidelines for design services and product deliverables. Following these guidelines will result in nationally uniform and predictable drawings sets, specifications, design materials, and services. Such consistency will greatly aid the review, approval, and coordination processes.
- 1.2. Unless specifically noted in the Statement of Work, all Designers of Record and consultants are to use these guidelines in the preparation of all project documents—drawings, specifications, or any other submittal data.
- 1.3. Any document prepared for submittal to the BIA must be clear, concise, and legible. All information must be clearly titled and dated. Packages must be properly numbered or indexed to allow for easy content navigation.

**NOTICE TO CONTRACTORS**

**CONTRACTOR**  
**PRE-QUALIFICATION STATEMENT, Page 1 of 10**

\_\_\_\_\_ is pre-qualifying general contractors for the  
construction \_\_\_\_\_ located on the  
within the \_\_\_\_\_ Indian Reservation at \_\_\_\_\_

The \_\_\_\_\_ project is to be bid in  
\_\_\_\_\_ as part of the \_\_\_\_\_ capital improvement program.

To pre-qualify:

1. Firms are NOT to contact or visit the \_\_\_\_\_ site.
2. Pre-qualification questionnaire forms will be faxed or mailed to prospective contractors who request them.
3. Contractor responses shall be Fed-Xed, Express Mailed, Mailed or Hand-deliver with one signed original and five (5) hard copies of the completed pre-qualification form to ensure it is received no later than \_\_\_\_\_ P.M., \_\_\_\_\_  
\_\_\_\_\_ Time, \_\_\_\_\_ at \_\_\_\_\_  
\_\_\_\_\_ Office located at \_\_\_\_\_
4. In the upper left hand area of the envelop, provide a label identifying the Pre-qualification Form and the Firm's name and address.
5. Address the information to the attention of:

\_\_\_\_\_  
\_\_\_\_\_  
\_\_\_\_\_  
\_\_\_\_\_  
\_\_\_\_\_

The number of pre-qualified contractors shall be determined by the \_\_\_\_\_ at the time the responses are reviewed and evaluated by the \_\_\_\_\_ in a fair and unbiased manner and in the best interest of the \_\_\_\_\_. The \_\_\_\_\_ reserves the right to qualify the firm(s) that best meet the \_\_\_\_\_ project needs and the evaluation criteria as set forth by the \_\_\_\_\_, i.e. past performance, client references, quality of work, safety record, financial capability, etc.

**CONTRACTOR**  
**PRE-QUALIFICATION STATEMENT, Page 2 of 10**

1.0 Construction project to be pre-qualified for: \_\_\_\_\_  
\_\_\_\_\_ **Project.**

2.0 Provide Firm Information, local office and principle office if other than local office designated:

|                           |                           |
|---------------------------|---------------------------|
| <b>Local Office:</b>      | <b>Principle Office:</b>  |
| Current Legal Name: _____ | Current Legal Name: _____ |
| Street Address: _____     | Street Address: _____     |
| City/State/Zip: _____     | City/State/Zip: _____     |
| Tele. Number: _____       | Tele. Number: _____       |
| Fax Number: _____         | Fax Number: _____         |
| E-Mail Address: _____     | E-Mail Address: _____     |

2.1 How many years has your firm been in business as ?

2.2 How many years has your firm been in business as a firm in the State of \_\_\_\_\_?

2.3 List the names in order of succession under which your firm has previously operated as a General Contractor Firm.

2.4 How many years has your firm been in operation at the current address?

3.0 Please check the appropriate category to identify the nature of your Firm?

|                                      |  |
|--------------------------------------|--|
| <input type="checkbox"/> Corporation | <input type="checkbox"/> Joint Venture |
| <input type="checkbox"/> Partnership | <input type="checkbox"/> Other         |
| <input type="checkbox"/> Individual  |  |

3.1 Corporations provide the following information:

Date Firm Incorporated \_\_\_\_\_

**CONTRACTOR**  
**PRE-QUALIFICATION STATEMENT, Page 3 of 10**

State where Firm is incorporated \_\_\_\_\_  
County where Firm is incorporated \_\_\_\_\_  
Name of President \_\_\_\_\_  
Name of Vice President (s) \_\_\_\_\_  
Name of Secretary \_\_\_\_\_  
Name of Chief Financial Officer \_\_\_\_\_

**3.2 Partnership or individual provide the following information:**

Date Firm established?: \_\_\_\_\_  
Name and address of individual/partners (Indicate partners and whether  
general or limited partners)

\_\_\_\_\_  
\_\_\_\_\_  
\_\_\_\_\_  
\_\_\_\_\_

**3.3 Joint Venture provides the following information:**

Name and address of each firm participating in the joint venture.

\_\_\_\_\_  
\_\_\_\_\_  
\_\_\_\_\_  
\_\_\_\_\_

Identify name(s) of other projects, project location, owner, architect and  
contract amount which are under construction or have been completed as  
a joint venture.

\_\_\_\_\_  
\_\_\_\_\_  
\_\_\_\_\_  
\_\_\_\_\_

Name and addresses of principals.

\_\_\_\_\_

**CONTRACTOR**  
**PRE-QUALIFICATION STATEMENT, Page 4 of 10**

\_\_\_\_\_  
\_\_\_\_\_  
\_\_\_\_\_

Describe Organization.

\_\_\_\_\_

3.4 Other types of firms: describe the organization and list the names and addresses of principals. (Use additional sheet if necessary).

\_\_\_\_\_  
\_\_\_\_\_

3.5 In what states is your firm legally qualified to do business? \_\_\_\_\_

3.6 In what state is your trade name or partnership filed?

3.7 Provide an **organizational chart** of your firm.

4.0 What type of work and approximately what percentage of work would be performed by your own forces on this project?

|          | Approximate % |
|----------|---------------|
| General: | _____         |
| Other:   | _____         |
| _____    | _____         |
| _____    | _____         |
| _____    | _____         |
| _____    | _____         |

5.0 Has your firm failed to accept a contract award or to complete a contract awarded to you? If "yes":

5.1 If your response was "yes" to the previous question please state the project(s), date, owner and reason.

6.0 Has your firm, under another or previous name, failed to accept a contract award or to complete a contract awarded to you? If "yes", please state name and address:

**CONTRACTOR**  
**PRE-QUALIFICATION STATEMENT, Page 5 of 10**

- 6.1 If your response was "yes" to the previous question please state the project(s), date, owner and reason.
- 7.0 Within the last five years, has any owner, officer or partner of your organization ever been an owner, officer or partner of another organization when it failed to complete a contract. If "yes":
- 7.1 If your response was "yes" to the previous question, please attach a separate sheet with explanation.
- 8.0 Has your firm ever had a contract terminated? If "yes":
- 8.1 If "yes", state the project(s), date, owner and reason.  
\_\_\_\_\_
- 9.0 Bonding information:
- Name of Bonding Company: \_\_\_\_\_  
Bests Rating: \_\_\_\_\_  
Bests Financial Rating: \_\_\_\_\_  
Name and address of Bonding Company agent: \_\_\_\_\_
- Bonding Capacity: \_\_\_\_\_ Maximum Bonding Value: \_\_\_\_\_  
Current Value of bonded Projects: \_\_\_\_\_
- 10.0 Has your bonding Company ever been required to perform under a bid bond, labor and material payment bond, or performance bond issued on your firm's behalf? If "yes":
- 10.1 If "yes", state the project(s), date, owner and reason.
- 11.0 Within the last five years has your current firm or any predecessor organization been involved as a party in any bankruptcy, litigation or arbitration proceedings? If "yes":
- 11.1 If your response was "yes" to the previous question, please attach a separate sheet with explanation.
- 12.0 **Current Work**: On a separate page list the projects your firm currently has in



**CONTRACTOR**  
**PRE-QUALIFICATION STATEMENT, Page 6 of 10**

progress stating the name of the owner and telephone number, the name of the architect and telephone number, location of the project, name of project, original contract amount, current contract amount, percentage of completion, and scheduled completion date.

13.0 **Relevant General Experience:** Complete the Example of Relevant Projects Form (Attachment A) for projects that your firm has completed during the past five years stating the name of the owner and telephone number, name of the architect/engineer of record and telephone number, location of project, original contract amount, final contract amount, original contract completion date, actual contract completion date, and percentage of work completed with your own forces. Identify whether your firm has completed those projects as a prime or sub-contractor.

14.0 **Resumes and Specific Experience:** Provide on separate sheets of paper, the following: resumes/experience for key staff in your firm including Project Manager, Project Superintendent, estimators, or others that will work on the Project. Include reference contact information for the past five years, projects for Project Manager and Superintendent.

14.1 List the Project Manager and Project Superintendent that you anticipate assigning to a project. The Project Superintendent must be assigned to the project full time and for the duration of the project.

Project Manager: \_\_\_\_\_  
Project Superintendent: \_\_\_\_\_

14.2 List other projects already assigned to the project manager and superintendent listed in the pre-qualification statement, including the completion date of each project.

14.3 List the projects which your firm has had **Native American Project Experience**, i.e., past performance on contracts with Native American organizations, tribal governments, tribal schools, TERO (Tribal Employment Rights Ordinance) requirements and federal agencies, i.e., Indian Health Service and Bureau of Indian Affairs.

\_\_\_\_\_  
\_\_\_\_\_

**CONTRACTOR**  
**PRE-QUALIFICATION STATEMENT, Page 7 of 10**

- 14.4 Has your firm had any experience where **Commissioning Agents** were required to Commission the project's Mechanical, Electrical and Plumbing systems? If "yes", please describe and list. Note: particular attention will be paid to the qualifications, during the bidding review process, of the above building trades and **Commissioning Agents** will be employed by the School for this renovation project.
- 15.0 Does your firm have a company wide safety program? If "yes":
- 15.1 Is a copy of the safety program available to the Standing Rock Community School for examination?
- 15.2 Attach a standard site safety plan.
- 15.3 Does your firm have a safety officer? If yes, attach a resume.
- 16.0 What is your current Experience Modification Rate (EMR) for Workman's Compensation for the past three years?
- 17.0 Does your firm have a pre-hire drug testing program  
If "yes":
- 17.1 Does your firm require that subcontractors working on your project have a pre-hire drug-testing program?
- 17.2 Does your firm have a policy to insure a drug free work place?
- 17.3 Is a copy of the procedure to enforce this policy available to the  
for examination?
- 18.0 Is your firm familiar with the requirements of the Tribal Employment Rights Ordinance (TERO)
- 19.0 Attach an **Audited Financial Statement** including your firm's latest balance sheet and income statement showing the following items. Note: This ***is*** a requirement.:

Current Assets, Net Fixed Assets, Other Assets, Current Liabilities, Other

**CONTRACTOR**  
**PRE-QUALIFICATION STATEMENT, Page 8 of 10**

**Liabilities.**

Name of Firm preparing financial statement and date prepared.

Explain any difference between Firm for which financial statement was prepared and Firm listed in section 2.0 of this statement (e.g., parent, subsidiary, joint venture, etc.).

**19.1 Bank References, List:**

\_\_\_\_\_  
\_\_\_\_\_  
\_\_\_\_\_

**19.2 Trade and/ or Vendor References:**

\_\_\_\_\_                      \_\_\_\_\_  
\_\_\_\_\_                      \_\_\_\_\_  
\_\_\_\_\_                      \_\_\_\_\_

**AFFIDAVIT**  
**(Notarized)**

STATE OF: \_\_\_\_\_

Sworn Statement

COUNTY OF: \_\_\_\_\_

The undersigned, being duly sworn, hereby declares: That all statements and answers to interrogatories in this Contractors's Pre-qualification Statement are true; that the financial statement accurately reflects the financial condition of the individual firm, partnership, corporation or joint venture named as the date given.

It is understood that this statement is for the express purpose of obtaining pre-qualification to bid on work let by contract by the \_\_\_\_\_ and that any depository, vendor, or other agency herein named is hereby authorized to supply the \_\_\_\_\_ with any information necessary to verify \_\_\_\_\_

**CONTRACTOR**  
**PRE-QUALIFICATION STATEMENT, Page 9 of 10**

this statement.

**ACKNOWLEDGMENT\***

On this \_\_\_\_\_ day of \_\_\_\_\_, 20\_\_\_\_, personally appeared before me \_\_\_\_\_ known to me to be the person named in and who executed the foregoing instrument and acknowledged that they executed the same.

(Notary Seal)

\_\_\_\_\_  
NOTARY PUBLIC (Type or Print name)

\_\_\_\_\_  
NOTARY PUBLIC (Signature)

My Commission Expires: \_\_\_\_\_

**CONTRACTOR:**

\_\_\_\_\_  
Name of Firm

\_\_\_\_\_  
Officer's Name (Type or Print)

\_\_\_\_\_  
Signature

\_\_\_\_\_  
Title

\_\_\_\_\_  
Date

\* For individual business, affidavit to be signed by owner and notarized.  
For partnership, affidavit to be signed by all partners and notarized.  
For corporation, LLC, PLLC, LLP, PLLP, or Limited Partnership affidavit to be signed by an authorized official and notarized.  
For a Joint Venture, affidavit to be signed by an authorized official of each Joint Venture participant.

**ATTACHMENT "A"**

**CONTRACTOR  
PRE-QUALIFICATION STATEMENT, Page 10 of 10**

*EXAMPLES OF RELEVANT PROJECTS FORM*  
(Completed during the past five years)

**General Project Information:**

Project Name: \_\_\_\_\_

Owner/Client,  
Contract name and  
Telephone #: \_\_\_\_\_  
\_\_\_\_\_

Architect/Engineer of  
Record, contact name  
and Telephone #: \_\_\_\_\_  
\_\_\_\_\_

**Facility Information:**

Type of Facility: \_\_\_\_\_

Project Description: \_\_\_\_\_  
\_\_\_\_\_

Renovation \_\_\_\_\_ Addition \_\_\_\_\_ New Building \_\_\_\_\_

Square Ft., Add'n/New: \_\_\_\_\_

Square Ft. of Renovation: \_\_\_\_\_

**Schedule Information:**

Planned Construction Completion Date: \_\_\_\_\_

Actual Construction Completion Date: \_\_\_\_\_

**Cost Information:**

Low Bid or Award Amount: \_\_\_\_\_

Final Construction Cost: \_\_\_\_\_

**2010-1. General**

- 1.1. This section outlines the submittal requirements at each design stage and the responsibilities of the Designer of Record during each phase. Submittals are required at 20 percent completion (schematic design), 40 percent completion (design development), 70 percent completion (preliminary construction documents), 99 percent completion (completed construction documents), and 100 percent completion (final construction documents). Drawings required in each submittal shall be as discussed in Section 2040, with the exception of design presentation boards. Specifications format is discussed in further detail in Section 2050.
- 1.2. **Written Comments.** After each review, the Designer of Record will be furnished written comments to be annotated and returned to the BIA. Comments shall be annotated as A=Concur, D=Do Not Concur, or E=Exception.
  - 1.2.1. Comments annotated with D or E shall be explained to justify noncompliance with the comment. Comments annotated with A may also be annotated with additional comments. These annotations will, in addition to explanations previously required, include a brief annotation for all comments concurred with as to what action was taken and where.
  - 1.2.2. The Designer of Record may request a meeting or phone conference to discuss D or E comments with the BIA. Schedule meetings no later than 7 calendar days after receipt of all comments for each submittal Phase..
  - 1.2.3. The Designer of Record shall furnish all annotated comments to the BIA no later than 14 calendar days after receipt of all comments for each submittal Phase.
  - 1.2.4. After each submittal, the Designer of Record shall make any corrections necessary. The Designer of Record shall not proceed or initiate any work on any successive design level prior to receipt of approval of the preceding design level.

**2010-2. 20 Percent Completion – Schematic Design Submittal**

- 2.1. **General.** The 20 percent completion schematic design submittal will comprise the documents necessary to illustrate the general scope, scale, arrangement, and relationships of project components. At this stage, the design will be conceptual. The content of the schematic design package shall include, but not be limited to, the following information:

| <b>20% Submittal Requirements – Schematic Design Phase</b> |   |            |           |            |
|--|---|------------|-----------|------------|
| <b>General</b>   |   |            |           |            |
| <b>Item No.</b>  | <b>Submittal Requirement</b>  | <b>Yes</b> | <b>No</b> | <b>N/A</b> |
| 1  | Update any previous schedule for milestones, submittals, contracting, and construction.   |            |           |            |
| 2  | Develop probable costs based on the schematic design information. In the event the project cost estimate exceeds the established budget, the Designer of Record shall make recommendations and notify, in writing, the Contracting Officer for further direction. |            |           |            |
| 3  | Coordinate LEED documentation for 20% schematic design, illustrating proposed strategies for compliance with LEED requirements and ways to achieve certification goals.   |            |           |            |

| <b>20% Submittal Requirements – Schematic Design Phase</b> |   |            |           |            |
|--|---|------------|-----------|------------|
| <b>Civil</b>   |   |            |           |            |
| <b>Item No.</b>  | <b>Submittal Requirement</b>  | <b>Yes</b> | <b>No</b> | <b>N/A</b> |
| 1  | Communicate conceptual design solutions and alternatives in the civil narrative and drawings.   |            |           |            |
| 2  | Include graphic design of schematic land use.   |            |           |            |
| 3  | Show physical influences.   |            |           |            |
| 4  | Show property lines, north arrow, and scale.  |            |           |            |
| 5  | Show site access points.  |            |           |            |
| 6  | Show existing natural features.   |            |           |            |
| 7  | Show proposed roads and parking.  |            |           |            |
| 8  | Provide recommendations for controlling runoff.   |            |           |            |
| 9  | Show existing water and sanitation facilities with respective appurtenances indicated.  |            |           |            |
| 10   | Provide a detailed outline of proposed water and sanitation facilities, indicating point of connection to existing systems.           |            |           |            |
| 11   | Indicate all necessary valves, fire hydrants, ground storage tanks, pump stations, etc.   |            |           |            |
| 12   | Submit a chemical analysis of the water supply.   |            |           |            |
| 13   | Indicate all necessary treatment plants, manholes, lift stations, force mains, septic tanks, grease traps, oil/water separators, etc. |            |           |            |
| 14   | Provide preliminary opinion of estimated cost.  |            |           |            |
| 15   | Provide a site survey.  |            |           |            |
| 16   | Provide a geotechnical report (if not provided with preliminary plan).  |            |           |            |

| <b>20% Submittal Requirements – Schematic Design Phase</b> |   |            |           |            |
|--|---|------------|-----------|------------|
| <b>Landscape</b>   |   |            |           |            |
| <b>Item No.</b>  | <b>Submittal Requirement</b>  | <b>Yes</b> | <b>No</b> | <b>N/A</b> |
| 1  | Communicate conceptual design solutions and alternatives in the landscape narrative and drawings.   |            |           |            |
| 2  | Develop conceptual design solutions for land forms, lawns, and plantings based on program requirements, physical site characteristics, design objectives, and environmental determinates. |            |           |            |
| 3  | Provide a conceptual layout of outdoor areas.   |            |           |            |

| <b>20% Submittal Requirements – Schematic Design Phase</b> |   |            |           |            |
|--|---|------------|-----------|------------|
| <b>Architectural</b>                                       |   |            |           |            |
| <b>Item No.</b>  | <b>Submittal Requirement</b>  | <b>Yes</b> | <b>No</b> | <b>N/A</b> |
| 1  | Communicate conceptual design solutions and alternatives in the architectural narrative and drawings.             |            |           |            |
| 2  | Provide conceptual site plan and building plans, including room numbers and areas.                                |            |           |            |
| 3  | Include an approximate footprint, areas, and volumes that meet the POR and adjacency requirements.                |            |           |            |
| 4  | Provide building shading and solar control analysis.  |            |           |            |
| 5  | Provide preliminary building sections and elevations.   |            |           |            |
| 6  | Provide a preliminary selection of building systems and materials.  |            |           |            |
| 7  | Provide perspective sketches and/or study models (electronic and/or physical) as required to describe the design. |            |           |            |
| 8  | Coordinate architectural work with that of engineering and other design disciplines involved in the project.      |            |           |            |
| 9  | Review and check documents prepared for the project.  |            |           |            |

| <b>20% Submittal Requirements – Schematic Design Phase</b> |  |            |           |            |
|--|--|------------|-----------|------------|
| <b>Structural</b>  |  |            |           |            |
| <b>Item No.</b>  | <b>Submittal Requirement</b>   | <b>Yes</b> | <b>No</b> | <b>N/A</b> |
| 1  | Communicate conceptual design solutions and alternatives in the structural narrative and drawings. |            |           |            |
| 2  | Provide structural design criteria including seismic design category.                              |            |           |            |



| 20% Submittal Requirements – Schematic Design Phase |  |     |    |     |
|---|--|-----|----|-----|
| Mechanical/Fire Protection                          |  |     |    |     |
| Item No.  | Submittal Requirement  | Yes | No | N/A |
| 1   | Communicate conceptual design solutions and alternatives in the mechanical narrative and drawings, including: <ul style="list-style-type: none"> <li>• Scope of project</li> <li>• Preliminary systems selections               <ul style="list-style-type: none"> <li>- HVAC, controls/EMS, plumbing, and fire protection</li> </ul> </li> <li>• Energy sources</li> <li>• Utility availability/capacities</li> <li>• Test bore for geo-exchange</li> <li>• Established building energy budget</li> </ul> |     |    |     |
| 2   | Provide design analysis, including: <ul style="list-style-type: none"> <li>• Building preliminary energy modeling</li> <li>• Matrix of LCCA options               <ul style="list-style-type: none"> <li>- including solar hot water</li> <li>- geo-exchange</li> </ul> </li> <li>• Supporting data/calculations</li> <li>• Fire protection design analysis</li> <li>• Seismic design requirements analysis</li> </ul>   |     |    |     |
| 3   | <ul style="list-style-type: none"> <li>• Review LEED requirements and provide strategies for compliance</li> </ul>   |     |    |     |

| 20% Submittal Requirements – Schematic Design Phase |   |     |    |     |
|---|---|-----|----|-----|
| Electrical  |   |     |    |     |
| Item No.  | Submittal Requirement   | Yes | No | N/A |
| 1   | Communicate conceptual design solutions and alternatives in the electrical narrative and drawings.  |     |    |     |
| 2   | Coordinate with utility company and provide available power characteristics.  |     |    |     |
| 3   | Provide generator recommendation.   |     |    |     |
| 4   | Provide lightning protection recommendation.  |     |    |     |
| 5   | Provide renewable energy source recommendation.   |     |    |     |
| 6   | Indicate lighting power density goal.   |     |    |     |
| 7   | Include a legend.   |     |    |     |
| 8   | Provide power plans, including: <ul style="list-style-type: none"> <li>• Typical room layouts</li> <li>• Major equipment locations</li> </ul> |     |    |     |

|    |  |  |  |  |
|----|--|--|--|--|
| 9  | Provide lighting plans, including: <ul style="list-style-type: none"> <li>• Typical room layouts</li> <li>• Typical room point-by-point foot-candle calculations</li> </ul>  |  |  |  |
| 10 | Provide a one-line diagram, including: <ul style="list-style-type: none"> <li>• System voltage and phase</li> <li>• Preliminary equipment sizes</li> <li>• Conduit and wire sizing is not required</li> </ul>  |  |  |  |
| 11 | Provide sample schedules, including: <ul style="list-style-type: none"> <li>• Panel schedule</li> <li>• Switchboard</li> <li>• Motor control center</li> <li>• Feeder schedule</li> <li>• Mechanical schedule</li> <li>• Luminaire schedule</li> <li>• Transformer schedule</li> <li>• Kitchen equipment schedule</li> </ul> |  |  |  |

**20% Submittal Requirements – Schematic Design Phase**

**Information Technology**

| <b>Item No.</b> | <b>Submittal Requirement</b>   | <b>Yes</b> | <b>No</b> | <b>N/A</b> |
|-----------------|--|------------|-----------|------------|
| 1               | Communicate conceptual design solutions and alternatives for the IT systems in IT narrative and drawings. The narrative should also include the application of the IT Systems Selection Matrix used to determine the systems to be included. |            |           |            |
| 2               | Provide generalized plan views of a typical telecommunications room, entrance facility, and office, along with any other appropriate major spaces. These may either be inserted within the narrative or included as separate drawings.       |            |           |            |
| 3               | Indicate general space requirements and locations for major IT components.   |            |           |            |

**2010-3. 40 Percent Completion – Design Development Submittal**

**3.1. General.** Based upon the approved schematic design, design development documents are refinements of the project design. In the design development phase, the Designer of Record will establish the scope, relationships, forms, size, and appearance of the project. The design development package shall constitute a 40 percent construction documents level of detail. Plans, sections, elevations, typical construction details, and system and equipment layouts are included in this phase. Major materials and systems will be identified in the specifications, and minimum quality standards will be established. The content of the design development package shall include, but not be limited to, the following information:

| 40% Submittal Requirements – Design Development Phase |   |     |    |     |
|---|---|-----|----|-----|
| General   |   |     |    |     |
| Item No.  | Submittal Requirement   | Yes | No | N/A |
| 1   | Update the previous schedule for milestones, submittals, contracting, and construction.   |     |    |     |
| 2   | Develop probable costs based upon the design development information. Cost estimates are to be presented by division and section according to CSI <i>MasterFormat</i> . In the event the project cost estimate exceeds the established budget, the Designer of Record shall make recommendations and, during the preliminary construction documents phase, make any changes necessary to bring the project within budget. |     |    |     |
| 3   | For projects over \$1 million, a value engineering study is required. The Designer of Record shall assist the BIA with the value engineering effort. This effort will include the evaluation of value engineering recommendations for review by the BIA. The Designer of Record shall incorporate approved value engineering changes during the 70% preliminary construction documents phase.                             |     |    |     |
| 4   | Coordinate LEED documentation for 40% design development, indicating proposed strategies for compliance with LEED requirements and ways to achieve certification goals.   |     |    |     |
| 5   | The Designer of Record shall annotate the review comments in the development of data for the next design level. If any review comment requires clarification and/or amplification to assure understanding, the Designer of Record shall notify the Contracting Officer in writing.  |     |    |     |
| 6   | Incorporate all approved comments from the BIA review of the 20% schematic design submittal.  |     |    |     |

| 40% Submittal Requirements – Design Development Phase |  |     |    |     |
|---|--|-----|----|-----|
| Civil   |  |     |    |     |
| Item No.  | Submittal Requirement  | Yes | No | N/A |
| 1   | Include design development level completion of all previous 20% submittal requirements, including an updated design narrative.   |     |    |     |
| 2   | Provide basic site design.   |     |    |     |
| 3   | Describe project location, as well as factors and objectives influencing the site plan.  |     |    |     |
| 4   | Show existing site features, including topography, acreage, boundaries, benchmark (B.M.) datum, etc.   |     |    |     |
| 5   | Indicate requirements for flood protection.  |     |    |     |
| 6   | Indicate items requiring removal/relocation.   |     |    |     |
| 7   | Indicate site geometry, including setback or clearance requirements.   |     |    |     |
| 8   | Indicate erosion control measures implemented.   |     |    |     |
| 9   | Provide storm management plan with USGBC designs implemented to the fullest extent possible.   |     |    |     |
| 10  | Indicate easement requirements.  |     |    |     |
| 11  | Indicate existing site features such as buildings, streets, curbs, walks, fences, planted areas, site screens, plazas, courtyards, fountains, watercourses, ponds, elevation of high water, rock outcrops, etc.                        |     |    |     |
| 12  | Indicate planned finished floor elevations and critical spot elevations.   |     |    |     |
| 13  | Indicate preliminary design analysis and calculations for site earthwork (cut or fill requirements and rough estimate of quantities) and drainage control.   |     |    |     |
| 14  | Indicate complete drainage concept using either finished contours or slope arrows, and estimate storm drain pipe sizes.  |     |    |     |
| 15  | Indicate existing utilities within the topography; show removals, relocations, and new work for utilities on separate plans; indicate critical depths and overhead clearances. (Utilities include gas, electric, drainage lines, etc.) |     |    |     |
| 16  | Show schematic layout of wastewater and water collection and treatment systems, indicating invert elevations of all new and existing sanitary sewer and waterlines and top and invert elevations of all new and existing manholes.     |     |    |     |
| 17  | Indicate existing soil conditions affecting design.  |     |    |     |
| 18  | Indicate design values for flexible and rigid pavements.   |     |    |     |

|    |   |  |  |  |
|----|---|--|--|--|
| 19 | Indicate road design including all dimensions, slopes, and paralleling structures (curbs, sidewalks, guardrails, traffic signs, markings, fencing, etc.). |  |  |  |
| 20 | Indicate parking and open storage areas, number, sizes, locations, access, etc.   |  |  |  |
| 21 | Indicate new work and connections to existing distribution system on water and sanitary site plans.   |  |  |  |
| 22 | Include details to obtain adequate cost estimates for items such as lift stations, septic tanks, oil separators, etc.                                     |  |  |  |
| 23 | Update to 40% design development phase cost estimate.   |  |  |  |
| 24 | Provide outline or draft specifications.  |  |  |  |
| 25 | Provide detailed calculations and criteria for the items listed above.  |  |  |  |
| 26 | Review comments and provide responses.  |  |  |  |

**40% Submittal Requirements – Design Development Phase**

**Landscape**

| <b>Item No.</b> | <b>Submittal Requirement</b>  | <b>Yes</b> | <b>No</b> | <b>N/A</b> |
|-----------------|---|------------|-----------|------------|
| 1               | Include design development level completion of all previous 20% submittal requirements, including an updated design narrative. Additional submittal requirements include the following: |            |           |            |
| 2               | Preliminary landscape plan  |            |           |            |
| 3               | Preliminary irrigation plan   |            |           |            |
| 4               | Typical landscape details   |            |           |            |
| 5               | Outline or draft specifications   |            |           |            |

| <b>40% Submittal Requirements – Design Development Phase</b> |   |            |           |            |
|--|---|------------|-----------|------------|
| <b>Architectural</b>   |   |            |           |            |
| <b>Item No.</b>  | <b>Submittal Requirement</b>  | <b>Yes</b> | <b>No</b> | <b>N/A</b> |
| 1  | Include design development level completion of all previous 20% submittal requirements, including an updated design narrative. Additional submittal requirements include the following: |            |           |            |
| 2  | Plans, including code plans, floor plans, roof plans, and reflected ceiling plans. Code plans shall include areas for each space. Plans shall include major dimensions.                 |            |           |            |
| 3  | Building sections and elevations  |            |           |            |
| 4  | Critical interior elevations  |            |           |            |
| 5  | Typical details and wall sections   |            |           |            |
| 6  | Typical casework elevations   |            |           |            |
| 7  | Final materials selections  |            |           |            |
| 8  | Equipment layouts   |            |           |            |
| 10   | Typical interior details of construction  |            |           |            |
| 11   | Perspective sketches and/or study models (electronic or physical) as required to describe the design  |            |           |            |
| 12   | Outline or draft specifications   |            |           |            |

| <b>40% Submittal Requirements – Design Development Phase</b> |   |            |           |            |
|--|---|------------|-----------|------------|
| <b>Structural</b>  |   |            |           |            |
| <b>Item No.</b>  | <b>Submittal Requirement</b>  | <b>Yes</b> | <b>No</b> | <b>N/A</b> |
| 1  | Include design development level completion of all previous 20% submittal requirements, including an updated design narrative. Additional submittal requirements include the following: |            |           |            |
| 2  | Final structural design criteria  |            |           |            |
| 3  | Structural foundation plan identifying the foundation system and defining representative sizes and depths   |            |           |            |
| 4  | Structural floor framing plan identifying the floor framing system and lateral system with representative member sizes  |            |           |            |
| 5  | Structural roof framing plan identifying the roof framing system and lateral system with representative member sizes  |            |           |            |
| 6  | Representative details defining critical dimensions of the structure  |            |           |            |
| 7  | Outline or draft specifications   |            |           |            |

| 40% Submittal Requirements – Design Development Phase |   |     |    |     |
|---|---|-----|----|-----|
| Mechanical/Fire Protection                            |   |     |    |     |
| Item No.  | Submittal Requirement   | Yes | No | N/A |
| 1   | Include design development level completion of all previous 20% submittal requirements, including an updated design narrative. Additional submittal requirements include the following:   |     |    |     |
| 2   | Finalized design analysis, including: <ul style="list-style-type: none"> <li>• Recommended LCCA items</li> </ul>  |     |    |     |
| 3   | Mechanical and plumbing legends   |     |    |     |
| 4   | Preliminary mechanical schedules  |     |    |     |
| 5   | Outline or draft specifications   |     |    |     |
| 6   | Full-building HVAC plans illustrating: <ul style="list-style-type: none"> <li>• Equipment locations</li> <li>• Initial mechanical room layouts</li> <li>• One-line of ductwork layout</li> <li>• One-line of main piping layout</li> <li>• Piping/HVAC flow diagrams</li> </ul> |     |    |     |
| 7   | Full-building plumbing plans illustrating: <ul style="list-style-type: none"> <li>• Water and sewer entrances</li> <li>• One-line of roof drainage</li> <li>• One-line of main plumbing lines</li> <li>• Initial riser diagrams</li> </ul>                                      |     |    |     |
| 8   | Temperature controls/EMS design, including: <ul style="list-style-type: none"> <li>• Control diagrams</li> <li>• I/O list in outline specification</li> <li>• Sequence of operation in outline specification</li> <li>• Temperature control zone plan</li> </ul>                |     |    |     |
| 9   | Fire protection design, including: <ul style="list-style-type: none"> <li>• Draft performance specification</li> <li>• Plan for location of utility interface, fire protection header, etc.</li> <li>• Flow test results</li> <li>• Zone area plans</li> </ul>                  |     |    |     |

|    |   |  |  |  |
|----|---|--|--|--|
| 10 | Preliminary calculations, including: <ul style="list-style-type: none"> <li>• Heating and cooling load</li> <li>• Utility pipe sizing</li> <li>• Plumbing fixture count</li> <li>• Pipe stress (preliminary)</li> <li>• Acoustical evaluation (preliminary)</li> <li>• Friction calculations – air/liquid (preliminary)</li> <li>• Other</li> </ul> |  |  |  |
| 11 | Makeup water test analysis results, including: <ul style="list-style-type: none"> <li>• Water treatment recommendations</li> </ul>  |  |  |  |
| 12 | Review of design for compliance with LEED requirements: <ul style="list-style-type: none"> <li>• Energy budget met</li> <li>• No CFCS or HCFCs</li> <li>• Early involvement of Commissioning Agent</li> <li>• Zone control strategies achieved</li> <li>• Other</li> </ul>  |  |  |  |



| 40% Submittal Requirements – Design Development Phase |   |     |    |     |
|---|---|-----|----|-----|
| Electrical  |   |     |    |     |
| Item No.  | Submittal Requirement   | Yes | No | N/A |
| 1   | Include design development level completion of all previous 20% submittal requirements, including an updated design narrative. Sample schedules are <u>not</u> required. Additional submittal requirements include the following:   |     |    |     |
| 2   | Site plans illustrating: <ul style="list-style-type: none"> <li>• Utility company coordination</li> <li>• Utility transformer location</li> <li>• Feeder routing, overhead vs. underground</li> <li>• All exterior light fixture locations</li> <li>• Exterior point-by-point foot-candle calculations</li> </ul> |     |    |     |
| 3   | Renewable energy source location  |     |    |     |
| 4   | Full-building power plans illustrating: <ul style="list-style-type: none"> <li>• Panel, switchgear, and transformer locations</li> <li>• Receptacle locations</li> </ul>  |     |    |     |
| 5   | Full-building lighting plans illustrating: <ul style="list-style-type: none"> <li>• All interior fixture locations</li> <li>• Fixture designations</li> <li>• Specialty area point-by-point foot-candle calculations</li> <li>•</li> </ul>  |     |    |     |
| 6   | Fire alarm plans illustrating: <ul style="list-style-type: none"> <li>• Device locations</li> </ul>   |     |    |     |
| 7   | One-line diagram illustrating: <ul style="list-style-type: none"> <li>• Preliminary load calculations</li> </ul>  |     |    |     |
| 8   | Luminaire schedule  |     |    |     |
| 9   | Outline or draft specifications   |     |    |     |

| <b>40% Submittal Requirements – Design Development Phase</b> |   |            |           |            |
|--|---|------------|-----------|------------|
| <b>Information Technology</b>                                |   |            |           |            |
| <b>Item No.</b>  | <b>Submittal Requirement</b>  | <b>Yes</b> | <b>No</b> | <b>N/A</b> |
| 1  | Include design development level completion of all previous 20% submittal requirements, including an updated design narrative. Additional submittal requirements include the following:   |            |           |            |
| 2  | Outline or draft specifications   |            |           |            |
| 3  | Preliminary drawings, including but not limited to: <ul style="list-style-type: none"> <li>• Title sheet with IT-specific symbols</li> <li>• Site plan</li> <li>• Riser diagram for communications cabling systems</li> <li>• Riser diagram for pathway/raceway/sleeves</li> <li>• One-line diagrams for all applicable systems</li> <li>• Scaled floor plans showing device locations</li> <li>• Enlarged communication rooms (and other IT spaces as required)</li> </ul> |            |           |            |
| 4  | Drawings complete with notes developed to a preliminary level   |            |           |            |

**2010-4. 70 Percent Completion – Preliminary Construction Documents Submittal**

- 4.1. General.** In the 70 percent preliminary construction documents phase, the Designer of Record refines the approved design development information to establish the requirements for the construction of the work. The 70 percent construction documents will include near-complete drawings and specifications to establish in detail the quality levels and construction of building materials, components, and systems. The content of the 70 percent construction documents package shall include, but not be limited to, the following information:

| <b>70% Submittal Requirements – Preliminary Construction Documents Phase</b> |   |            |           |            |
|--|---|------------|-----------|------------|
| <b>General</b>   |   |            |           |            |
| <b>Item No.</b>  | <b>Submittal Requirement</b>  | <b>Yes</b> | <b>No</b> | <b>N/A</b> |
| 1  | Update the previous schedule for milestones, submittals, contracting, and construction.   |            |           |            |
| 2  | Develop probable costs based upon the preliminary construction documents information. Cost estimates are to be presented by division and section according to <i>CSI MasterFormat</i> . In the event the estimated project cost exceeds the established budget, the Designer of Record shall make recommendations necessary to bring the project within budget and notify the Contracting Officer, in writing, before proceeding. |            |           |            |
| 3  | Coordinate LEED documentation for 70% preliminary construction documents, indicating proposed strategies for compliance with LEED requirements and ways to achieve certification goals.   |            |           |            |
| 4  | Incorporate all approved comments from the BIA review of the 40% design development submittal.  |            |           |            |

| <b>70% Submittal Requirements – Preliminary Construction Documents Phase</b> |  |            |           |            |
|--|--|------------|-----------|------------|
| <b>Civil</b>   |  |            |           |            |
| <b>Item No.</b>  | <b>Submittal Requirement</b>   | <b>Yes</b> | <b>No</b> | <b>N/A</b> |
| 1  | Include preliminary construction document level completion of all previous 40% submittal requirements with the exception of an updated design narrative. |            |           |            |
| 2  | Integrate the approved site development and data into working drawings.  |            |           |            |
| 3  | Provide location and vicinity maps.  |            |           |            |
| 4  | Develop detail sheets with proper references.  |            |           |            |
| 5  | Complete geometric layout of all items of new work using offset dimensions from existing structures, or use coordinates for locating new work.           |            |           |            |

|    |   |  |  |  |
|----|---|--|--|--|
| 6  | Develop new site grading, street plan, and profile with proper drainage, and include information of specific items of work, soil boring locations, and designations, coordinated with test hole locations and logs. |  |  |  |
| 7  | Complete the legend using all items and symbols shown on the plan, maintaining consistency between drawings.  |  |  |  |
| 8  | Indicate limits of construction disturbance, and provide narrative delineating areas to be restored.  |  |  |  |
| 9  | Provide an erosion control plan, including control objectives comparing post- and pre-development conditions.   |  |  |  |
| 10 | Describe temporary and permanent erosion and storm water control measures.  |  |  |  |
| 11 | Describe type and frequency of required maintenance activities for erosion control facilities.  |  |  |  |
| 12 | Provide complete storm drainage design calculations consistent with previous design submittals.   |  |  |  |
| 13 | Provide a map outlining drainage areas.   |  |  |  |
| 14 | Provide calculations for sizing retention and/or detention ponds.   |  |  |  |
| 15 | Provide watertight joints for drainage pipe under all pavements when the pipe is in non-cohesive soil.  |  |  |  |
| 16 | Complete and present flexible and rigid pavement design calculations.   |  |  |  |
| 17 | Describe nature of paving materials and provide typical pavement sections, as well as minimum compaction requirements.  |  |  |  |
| 18 | Include all items of work superimposed on the existing topography, and establish a base control system for locations (buildings, streets, walks, etc.).   |  |  |  |
| 19 | Indicate proposed contours for new grading and provide spot elevations as required to facilitate site layout.   |  |  |  |
| 20 | Lay out storm drainage using symbols per legend; identify drainage structures; provide profiles for all storm drains and culverts.  |  |  |  |
| 21 | Indicate top and flowline elevations of all drainage structures, size and invert elevations for storm pipe, ground profile, and new or existing utility crossings.  |  |  |  |
| 22 | Locate monuments and benchmarks for horizontal and vertical control.  |  |  |  |
| 23 | Indicate finished floor elevations of the new buildings.  |  |  |  |
| 24 | Show on the plan the construction centerline, right-of-way limits, and all important topographical features such as fences, buildings, streams, railroads, etc.   |  |  |  |

|    |   |  |  |  |
|----|---|--|--|--|
| 25 | Provide complete survey information necessary for establishment of the survey centerline, including pertinent bearings.   |  |  |  |
| 26 | Profiles shall provide elevations at points where changes of grade occur, as well as stationing elevations.   |  |  |  |
| 27 | Include typical sections through the site as required for clarity, as well as a legend.   |  |  |  |
| 28 | Include concrete joint details, layout, and sidewalk joints.  |  |  |  |
| 29 | Include storm drainage pipe and structure schedule.   |  |  |  |
| 30 | Include parking layout.   |  |  |  |
| 31 | Include roadway widening details and super-elevation information.   |  |  |  |
| 32 | Provide detailed floor plans and sections of treatment plants and pumping stations, with equipment layout, piping, and sufficient dimensions and elevations to physically locate all items of equipment, piping, etc. |  |  |  |
| 33 | Provide instrumentation and control schematics for pertinent machine systems, as well as equipment size, horsepower rating, and sequences of operation.   |  |  |  |
| 34 | Provide a site plan showing all existing and new valves, fire hydrants, manholes, pumping stations, laterals, meters, etc.  |  |  |  |
| 35 | Indicate all sizes of waterlines, sanitary sewers, and force mains.   |  |  |  |
| 36 | Provide invert and rim elevations for all manholes.   |  |  |  |
| 37 | Provide profiles of gravity sewers, and existing sewer line crossings; double lines are required for profile piping.  |  |  |  |
| 38 | Provide details for connecting new lines to existing systems.   |  |  |  |
| 39 | Provide profiles for water distribution and supply lines where crossings of other new or existing utilities occur.  |  |  |  |
| 40 | Provide layout of solid waste disposal system equipment and mode of operation.  |  |  |  |
| 41 | Provide plan of irrigation and/or sprinkler system, with flow requirements for each area.   |  |  |  |
| 42 | Provide complete specifications.  |  |  |  |
| 43 | Provide detailed calculations/criteria for items listed above.  |  |  |  |

| <b>70% Submittal Requirements – Preliminary Construction Documents Phase</b> |   |            |           |            |
|--|---|------------|-----------|------------|
| <b>Landscape</b>   |   |            |           |            |
| <b>Item No.</b>  | <b>Submittal Requirement</b>  | <b>Yes</b> | <b>No</b> | <b>N/A</b> |
| 1  | Include preliminary construction document level completion of all previous 40% submittal requirements with the exception of an updated design narrative. Additional submittal requirements include the following: |            |           |            |
| 2  | Planting legend and details   |            |           |            |
| 3  | Landscape plan illustrating all plant types, quantities, locations, size and condition  |            |           |            |
| 4  | Site amenities plan   |            |           |            |
| 5  | Site layout plan  |            |           |            |
| 6  | Landscape details   |            |           |            |
| 7  | Irrigation plan   |            |           |            |
| 8  | Irrigation details  |            |           |            |
| 9  | Site details  |            |           |            |
| 10   | Complete specifications for landscape and irrigation systems  |            |           |            |

| <b>70% Submittal Requirements – Preliminary Construction Documents Phase</b> |   |            |           |            |
|--|---|------------|-----------|------------|
| <b>Architectural</b>   |   |            |           |            |
| <b>Item No.</b>  | <b>Submittal Requirement</b>  | <b>Yes</b> | <b>No</b> | <b>N/A</b> |
| 1  | Include preliminary construction document level completion of all previous 40% submittal requirements with the exception of an updated design narrative. Additional submittal requirements include the following: |            |           |            |
| 2  | Floor plans indicating door swings, room names, general dimensions, location and identification of equipment, etc., coordinated with engineering disciplines  |            |           |            |
| 3  | Enlarged plans for detailed areas, including toilet rooms, mechanical rooms, etc.   |            |           |            |
| 4  | Stair and elevator core plans and sections  |            |           |            |
| 5  | Reflected ceiling plans indicating ceiling heights, finishes, and coordination with engineering disciplines   |            |           |            |
| 6  | Building sections as necessary indicating vertical dimensions, construction systems, and coordination with engineering disciplines  |            |           |            |
| 7  | Exterior building elevations indicating building dimensions, materials, and coordination with engineering disciplines   |            |           |            |

|    |  |  |  |  |
|----|--|--|--|--|
| 8  | Typical details and wall sections indicating materials, major features including beams, joists, foundations, etc., and illustrating bearing heights, finished floor elevations, etc. |  |  |  |
| 9  | Finish plan and schedule   |  |  |  |
| 10 | Door and window elevations and schedule  |  |  |  |
| 11 | Casework elevations  |  |  |  |
| 12 | Equipment layouts  |  |  |  |
| 13 | Kitchen equipment plans and details  |  |  |  |
| 14 | Furniture, furnishings, and equipment selections   |  |  |  |
| 15 | Interior construction details  |  |  |  |
| 16 | Complete specifications of all materials and systems   |  |  |  |

| 70% Submittal Requirements – Preliminary Construction Documents Phase |   |     |    |     |
|---|---|-----|----|-----|
| Structural  |   |     |    |     |
| Item No.  | Submittal Requirement   | Yes | No | N/A |
| 1   | Include preliminary construction document level completion of all previous 40% submittal requirements with the exception of an updated design narrative. Additional submittal requirements include the following: |     |    |     |
| 2   | Design criteria and general notes on the drawings   |     |    |     |
| 3   | Structural foundation plan showing all foundation elements  |     |    |     |
| 4   | Structural floor framing plan showing all floor framing members and sizes   |     |    |     |
| 5   | Structural roof framing plan showing all roof framing members.  |     |    |     |
| 6   | Complete structural specifications  |     |    |     |

| 70% Submittal Requirements – Preliminary Construction Documents Phase |  |     |    |     |
|---|--|-----|----|-----|
| Mechanical/Fire Protection  |  |     |    |     |
| Item No.  | Submittal Requirement  | Yes | No | N/A |
| 1   | Include preliminary construction document level completion of all previous 40% submittal requirements. An updated design narrative is not required. Additional submittal requirements include the following: |     |    |     |
| 2   | Updated mechanical/plumbing legends  |     |    |     |
| 3   | Updated mechanical schedules   |     |    |     |
| 4   | Complete mechanical specifications   |     |    |     |

|    |  |  |  |  |
|----|--|--|--|--|
| 5  | HVAC plans, sections, and details, including: <ul style="list-style-type: none"> <li>• Enlarged mechanical plans</li> <li>• Details of pumps, coils, chiller, boiler, AHU, etc.</li> <li>• Location and sizes of all equipment/systems</li> <li>• Two-lined ductwork</li> <li>• Sections of kitchen, multi-purpose, shops, and mechanical rooms</li> </ul> |  |  |  |
| 6  | Plumbing plans, including: <ul style="list-style-type: none"> <li>• Roof drainage</li> <li>• Waste/vent/water plumbing</li> <li>• Restroom and kitchen riser diagrams</li> <li>• Enlarge bathrooms and kitchens</li> </ul>   |  |  |  |
| 7  | Temperature controls/EMS design, including: <ul style="list-style-type: none"> <li>• Updated control drawings</li> <li>• Location plans for sensors/control devices and controllers</li> <li>• Updated I/O list and sequence of control in specification</li> </ul>  |  |  |  |
| 8  | Fire protection design, including: <ul style="list-style-type: none"> <li>• Updated performance specifications and equipment location drawings</li> </ul>  |  |  |  |
| 9  | Updated calculations, including: <ul style="list-style-type: none"> <li>• All systems</li> <li>• Seismic, acoustics, and piping stress calculations (as required)</li> <li>• Final building energy modeling</li> </ul>   |  |  |  |
| 10 | Review of design for compliance with LEED requirements: <ul style="list-style-type: none"> <li>• Review final LEED score card with team</li> </ul>   |  |  |  |

### 70% Submittal Requirements – Preliminary Construction Documents Phase

#### Electrical

| Item No. | Submittal Requirement   | Yes | No | N/A |
|----------|---|-----|----|-----|
| 1        | Include preliminary construction document level completion of all previous 40% submittal requirements. An updated design narrative is <u>not</u> required. Additional submittal requirements include the following: |     |    |     |
| 2        | Site plan: <ul style="list-style-type: none"> <li>• Utility meter and CT locations</li> <li>• Duct bank locations and details</li> <li>• Cathodic protection</li> <li>• Lighting circuiting</li> </ul>              |     |    |     |



|    |  |  |  |  |
|----|--|--|--|--|
| 3  | Renewable energy source: <ul style="list-style-type: none"> <li>• Size and characteristics</li> <li>• Utility company coordination</li> </ul>  |  |  |  |
| 4  | Power plans: <ul style="list-style-type: none"> <li>• Device circuiting</li> <li>• Mechanical equipment locations</li> <li>• Special system equipment locations</li> <li>• Correct physical sizing of panelboards, switchgear, transformers, etc., shown on the plans</li> </ul> |  |  |  |
| 5  | Lighting plans: <ul style="list-style-type: none"> <li>• Fixture circuiting</li> <li>• Lighting controls</li> </ul>  |  |  |  |
| 6  | Fire alarm plans: <ul style="list-style-type: none"> <li>• Fire protection requirements</li> </ul>   |  |  |  |
| 7  | One-line diagram: <ul style="list-style-type: none"> <li>• Wire and conduit sizes</li> </ul>   |  |  |  |
| 8  | Electrical details   |  |  |  |
| 9  | Schedules: <ul style="list-style-type: none"> <li>• Panel</li> <li>• Mechanical</li> <li>• Kitchen</li> </ul>  |  |  |  |
| 10 | Specifications <ul style="list-style-type: none"> <li>• Updated edit</li> </ul>  |  |  |  |
| 11 | Review of design for compliance with LEED requirements   |  |  |  |

### 70% Submittal Requirements – Preliminary Construction Documents Phase

#### Information Technology

| Item No. | Submittal Requirement   | Yes | No | N/A |
|----------|---|-----|----|-----|
| 1        | Include preliminary construction document level completion of all previous 40% submittal requirements with the exception of an updated design narrative. Additional submittal requirements include the following: |     |    |     |
| 2        | Preliminary specifications  |     |    |     |
| 3        | Drawings developed to a near-final level, setting forth in detail the IT construction requirements, including equipment layout and routing.   |     |    |     |
| 4        | Wall and equipment rack elevations added to the enlarged communications room(s) drawings  |     |    |     |
| 5        | Detail drawings developed to a preliminary level  |     |    |     |
| 6        | Drawings complete with notes developed to a near-final level  |     |    |     |

**2010-5. 99 Percent Completion – Completed Construction Documents Submittal**

- 5.1. General.** In the 99% completed construction documents phase, the Designer of Record refines the approved preliminary construction documents information to establish the completed requirements for the construction of the work. The completed construction documents will include all drawings and specifications to establish in detail the quality levels and construction of building materials, components, and systems. The content of the 99% completed construction documents package shall include, but not be limited to, the following information:

| <b>99% Submittal Requirements – Completed Construction Documents Phase</b> |  |            |           |            |
|--|--|------------|-----------|------------|
| <b>General</b>   |  |            |           |            |
| <b>Item No.</b>  | <b>Submittal Requirement</b>   | <b>Yes</b> | <b>No</b> | <b>N/A</b> |
| 1  | Update the previous schedule for milestones, submittals, contracting, and construction.  |            |           |            |
| 2  | Develop probable costs based on the completed construction documents. Cost estimates are to be presented in CSI format.  |            |           |            |
| 3  | Coordinate LEED documentation for 99% completed construction documents, including fully documented strategies for compliance with LEED requirements and ways to achieve certification goals. |            |           |            |
| 4  | Incorporate all approved comments from the BIA review of the 70% preliminary construction documents submittal.   |            |           |            |

| <b>99% Submittal Requirements – Completed Construction Documents Phase</b> |  |            |           |            |
|--|--|------------|-----------|------------|
| <b>Civil</b>   |  |            |           |            |
| <b>Item No.</b>  | <b>Submittal Requirement</b>   | <b>Yes</b> | <b>No</b> | <b>N/A</b> |
| 1  | Include completed construction document level development of all previous 70% submittal requirements.                  |            |           |            |
| 2  | Provide complete civil and site drawings.  |            |           |            |
| 3  | Show refined grades, dimensions, complete legends, specific and general notes, north arrows, etc.                      |            |           |            |
| 4  | Ensure correct cross-referencing among site drawings for appropriate details, sections, match lines, etc.              |            |           |            |
| 5  | Eliminate all conflicts (horizontal and vertical) among site plans and architectural, structural, and utilities plans. |            |           |            |
| 6  | Verify that terminology is consistent between plans and specifications for notations on specific items of work.        |            |           |            |
| 7  | Perform check for adequate referencing of construction details.  |            |           |            |
| 8  | Complete storm, water, and sanitary sewer drawings.  |            |           |            |
| 9  | Provide final erosion control plan (complete).   |            |           |            |

|    |  |  |  |  |
|----|--|--|--|--|
| 10 | Provide final drainage report and plan.                                  |  |  |  |
| 12 | Provide final civil construction specifications.                         |  |  |  |
| 12 | Provide final detailed calculations/criteria for the items listed above. |  |  |  |

**99% Submittal Requirements – Completed Construction Documents Phase**
**Landscape**

| Item No. | Submittal Requirement  | Yes | No | N/A |
|----------|--|-----|----|-----|
| 1        | Include completed construction document level development of all previous 70% submittal requirements. Additional submittal requirements include the following: |     |    |     |
| 2        | Completed planting legend and details  |     |    |     |
| 3        | Completed landscape plan illustrating all plant types, quantities, locations, size, and condition  |     |    |     |
| 4        | Completed site amenities plan  |     |    |     |
| 5        | Completed site layout plan   |     |    |     |
| 6        | Completed landscape details  |     |    |     |
| 7        | Completed irrigation plan  |     |    |     |
| 8        | Completed irrigation details   |     |    |     |
| 9        | Completed site details   |     |    |     |
| 10       | Complete specifications for landscape and irrigation systems   |     |    |     |

**99% Submittal Requirements – Completed Construction Documents Phase**
**Architectural**

| Item No. | Submittal Requirement  | Yes | No | N/A |
|----------|--|-----|----|-----|
| 1        | Include completed construction document level development of all previous 70% submittal requirements. Additional submittal requirements include the following:         |     |    |     |
| 2        | Completed floor plans indicating door swings, room names, general dimensions, location and identification of equipment, etc., coordinated with engineering disciplines |     |    |     |
| 3        | Completed enlarged plans for detailed areas, including toilet rooms, mechanical rooms, etc.  |     |    |     |
| 4        | Completed stair and elevator core plans and sections   |     |    |     |
| 5        | Completed reflected ceiling plans indicating ceiling heights, finishes, and coordination with engineering disciplines  |     |    |     |
| 6        | Completed building sections as necessary indicating vertical dimensions, construction systems, and coordination with engineering disciplines                           |     |    |     |

|    |   |  |  |  |
|----|---|--|--|--|
| 7  | Completed exterior building elevations indicating building dimensions, materials, and coordination with engineering disciplines |  |  |  |
| 8  | Completed details and wall sections as required to clearly delineate the construction requirements                              |  |  |  |
| 9  | Completed finish plan and schedule  |  |  |  |
| 10 | Completed door and window elevations and schedule   |  |  |  |
| 11 | Completed casework elevations   |  |  |  |
| 12 | Completed equipment layouts   |  |  |  |
| 13 | Completed kitchen equipment plan and details  |  |  |  |
| 15 | Interior details of construction  |  |  |  |
| 16 | Final construction specifications of all materials and systems  |  |  |  |

**99% Submittal Requirements – Completed Construction Documents Phase**

**Structural**

| <b>Item No.</b> | <b>Submittal Requirement</b>   | <b>Yes</b> | <b>No</b> | <b>N/A</b> |
|-----------------|--|------------|-----------|------------|
| 1               | Include completed construction document level development of all previous 70% submittal requirements. Additional submittal requirements include the following: |            |           |            |
| 2               | Geotechnical certification letter  |            |           |            |
| 3               | Final structural construction specifications   |            |           |            |

**99% Submittal Requirements – Completed Construction Documents Phase**

**Mechanical/Fire Protection**

| <b>Item No.</b> | <b>Submittal Requirement</b>   | <b>Yes</b> | <b>No</b> | <b>N/A</b> |
|-----------------|--|------------|-----------|------------|
| 1               | Include completed construction document level development of all previous 70% submittal requirements. Additional submittal requirements include the following: |            |           |            |
| 2               | Final mechanical/plumbing legends  |            |           |            |
| 3               | Final mechanical schedules   |            |           |            |
| 4               | Final mechanical specifications  |            |           |            |
| 5               | Final HVAC plans, sections, and details  |            |           |            |
| 6               | Final plumbing plans   |            |           |            |
| 7               | Final temperature control/EMS drawing  |            |           |            |
| 8               | Final mechanical construction specifications   |            |           |            |
| 9               | Final fire protection performance specification and drawings   |            |           |            |
| 10              | Final calculations   |            |           |            |

| <b>99% Submittal Requirements – Completed Construction Documents Phase</b> |   |            |           |            |
|--|---|------------|-----------|------------|
| <b>Electrical</b>  |   |            |           |            |
| <b>Item No.</b>  | <b>Submittal Requirement</b>  | <b>Yes</b> | <b>No</b> | <b>N/A</b> |
| 1  | Include completed construction document level development of all previous 70% submittal requirements. Additional submittal requirements include the following:  |            |           |            |
| 2  | Site plan: <ul style="list-style-type: none"> <li>Final plan</li> </ul>   |            |           |            |
| 3  | Renewable energy source: <ul style="list-style-type: none"> <li>Final design</li> <li>Disconnect location for connection <del>Tie</del> to power distribution</li> </ul>  |            |           |            |
| 4  | Power plans: <ul style="list-style-type: none"> <li>Final plans</li> </ul>  |            |           |            |
| 5  | Lighting plans: <ul style="list-style-type: none"> <li>Final plans</li> </ul>   |            |           |            |
| 6  | Fire alarm plans: <ul style="list-style-type: none"> <li>Final plans</li> <li>Coordination with mechanical equipment</li> </ul>   |            |           |            |
| 7  | One-line diagram: <ul style="list-style-type: none"> <li>Final plans</li> <li>Final load calculations</li> <li>Short-circuit ratings</li> <li>Arc flash calculations</li> <li>Coordination of breaker settings</li> </ul> |            |           |            |
| 8  | Final electrical construction specifications  |            |           |            |

| <b>99% Submittal Requirements – Completed Construction Documents Phase</b> |  |            |           |            |
|--|--|------------|-----------|------------|
| <b>Information Technology</b>  |  |            |           |            |
| <b>Item No.</b>  | <b>Submittal Requirement</b>   | <b>Yes</b> | <b>No</b> | <b>N/A</b> |
| 1  | Include completed construction document level development of all previous 70% submittal requirements. Additional submittal requirements include the following: |            |           |            |
| 2  | Final IT construction specifications   |            |           |            |
| 3  | Final drawings setting forth in detail the IT construction requirements  |            |           |            |

**2010-6. 100 Percent Completion – Final Construction Documents Submittal**

- 6.1. General.** In the 100 percent final construction documents phase, the Designer of Record finalizes the construction documents information to establish the completed requirements for the construction of the work, including incorporation of all accepted review comments. The final construction documents shall include all drawings and specifications to establish in detail the quality levels and construction of building materials, components, and systems. The content of the 100 percent final construction documents package shall include, but not be limited to, the following information:

| <b>100% Submittal Requirements – Final Construction Documents Phase</b> |   |            |           |            |
|---|---|------------|-----------|------------|
| <b>General</b>  |   |            |           |            |
| <b>Item No.</b>   | <b>Submittal Requirement</b>  | <b>Yes</b> | <b>No</b> | <b>N/A</b> |
| 1   | Update the previous schedule for milestones, submittals, contracting, and construction.   |            |           |            |
| 2   | Incorporate all approved comments from the BIA review of the 99% completed construction documents submittal.  |            |           |            |
| 3   | Coordinate LEED documentation for 100% final construction documents, including fully documented strategies for compliance with LEED requirements and ways to achieve certification goals. |            |           |            |

| <b>100% Submittal Requirements – Final Construction Documents Phase</b> |   |            |           |            |
|---|---|------------|-----------|------------|
| <b>Civil</b>  |   |            |           |            |
| <b>Item No.</b>   | <b>Submittal Requirement</b>                                      | <b>Yes</b> | <b>No</b> | <b>N/A</b> |
| 1   | Include all requirements of the 99% submittal plus the following: |            |           |            |
| 2   | Final specifications revised to reflect final review comments     |            |           |            |
| 3   | Drawings revised to reflect final review comments                 |            |           |            |

| <b>100% Submittal Requirements – Final Construction Documents Phase</b> |   |            |           |            |
|---|---|------------|-----------|------------|
| <b>Landscape</b>  |   |            |           |            |
| <b>Item No.</b>   | <b>Submittal Requirement</b>                                      | <b>Yes</b> | <b>No</b> | <b>N/A</b> |
| 1   | Include all requirements of the 99% submittal plus the following: |            |           |            |
| 2   | Final specifications revised to reflect final review comments     |            |           |            |
| 3   | Drawings revised to reflect final review comments                 |            |           |            |

| <b>100% Submittal Requirements – Final Construction Documents Phase</b> |   |            |           |            |
|---|---|------------|-----------|------------|
| <b>Architectural</b>  |   |            |           |            |
| <b>Item No.</b>   | <b>Submittal Requirement</b>                                      | <b>Yes</b> | <b>No</b> | <b>N/A</b> |
| 1   | Include all requirements of the 99% submittal plus the following: |            |           |            |
| 2   | Final specifications revised to reflect final review comments     |            |           |            |
| 3   | Drawings revised to reflect final review comments                 |            |           |            |

| <b>100% Submittal Requirements – Final Construction Documents Phase</b> |   |            |           |            |
|---|---|------------|-----------|------------|
| <b>Structural</b>   |   |            |           |            |
| <b>Item No.</b>   | <b>Submittal Requirement</b>                                      | <b>Yes</b> | <b>No</b> | <b>N/A</b> |
| 1   | Include all requirements of the 99% submittal plus the following: |            |           |            |
| 2   | Final specifications revised to reflect final review comments     |            |           |            |
| 3   | Drawings revised to reflect final review comments                 |            |           |            |
| 4   | Final structural calculations                                     |            |           |            |

| <b>100% Submittal Requirements – Final Construction Documents Phase</b> |   |            |           |            |
|---|---|------------|-----------|------------|
| <b>Mechanical/Fire Protection</b>                                       |   |            |           |            |
| <b>Item No.</b>   | <b>Submittal Requirement</b>                                      | <b>Yes</b> | <b>No</b> | <b>N/A</b> |
| 1   | Include all requirements of the 99% submittal plus the following: |            |           |            |
| 2   | Final specifications revised to reflect final review comments     |            |           |            |
| 3   | Drawings revised to reflect final review comments                 |            |           |            |

| <b>100% Submittal Requirements – Final Construction Documents Phase</b> |   |            |           |            |
|---|---|------------|-----------|------------|
| <b>Electrical</b>   |   |            |           |            |
| <b>Item No.</b>   | <b>Submittal Requirement</b>                                      | <b>Yes</b> | <b>No</b> | <b>N/A</b> |
| 1   | Include all requirements of the 99% submittal plus the following: |            |           |            |
| 2   | Final specifications revised to reflect final review comments     |            |           |            |
| 3   | Drawings revised to reflect final review comments                 |            |           |            |

| <b>100% Submittal Requirements – Final Construction Documents Phase</b> |   |            |           |            |
|---|---|------------|-----------|------------|
| <b>Information Technology</b>   |   |            |           |            |
| <b>Item No.</b>   | <b>Submittal Requirement</b>                                      | <b>Yes</b> | <b>No</b> | <b>N/A</b> |
| 1   | Include all requirements of the 99% submittal plus the following: |            |           |            |
| 2   | Final specifications revised to reflect final review comments     |            |           |            |
| 3   | Drawings revised to reflect final review comments                 |            |           |            |

**2010-7. Construction Procurement Services**

- 7.1.** If requested or approved by the BIA, the Designer of Record shall, following approval of the final construction documents, assist the BIA in obtaining bids or negotiated proposals and in awarding construction contracts. The responsibilities of the Designer of Record for construction procurement services shall include, but not be limited to, the following:
- Assist the BIA in the evaluation and validation of bids.
  - If requested by the BIA, arrange for reproduction and distribution of bidding documents to prospective bidders.
  - Maintain logs of bidding documents distributions, retrievals, and deposits.
  - Assist the BIA in considering substitution requests.
  - Provide clarifications and interpretations to questions from prospective bidders and prepare and distribute addenda.
  - Participate in a pre-bid conference for prospective bidders.
  - If requested by the BIA, participate in selection interviews with prospective contractors.
  - If requested by the BIA, participate in negotiations with prospective contractors.
- 7.2.** It is beneficial to BIA and the Designer of Record to invite qualified Contractors to bid projects. An example of a Pre-qualification Statement is included at the end of this Section for reference.



**2020-1. General**

- 1.1. It is expected that design work produced under these guidelines will be substantially free of deficiencies so that significant modifications or corrections do not need to be issued. Contractors should be able to complete the project satisfactorily working from the final construction documents. To this end, it is the Designer of Record's responsibility to coordinate their own work and the work of their consultants in preparing all drawings and specifications. All documents must be fully reviewed prior to their final release. Ensure that these documents are adequately detailed, properly cross-referenced, and complete; free of substantial omissions and repetition that contain significant conflicts. Any unresolved issues or unresolved conflicts that need response other Project Team members are to be brought to the attention of BIA in writing before documents are issued for final release.

**2020-2. Owner-Provided Data**

- 2.1. Owner-provided information and data must be well coordinated and incorporated into the appropriate documents. Data or recommendations from consultants working directly for the BIA are to be integrated into the design to the extent directed by the BIA.

**2020-3. Commissioning Agent**

- 3.1. The Designer of Record is required to coordinate and communicate with a third-party Commissioning Agent. The Commissioning Agent will be contracted directly to the Owner. The Designer of Record must provide one set of documents at each required submittal to the Commissioning Agent for their concurrent review. Their services are essential for achieving LEED accreditation. With the Owner's approval, the Designer of Record shall incorporate the Commissioning Agent's comments into the project.

**2020-4. Value Engineering (VE) Workshop**

- 4.1. The Designer of Record is required to participate in a VE workshop that will be completed no later than the Design Development (40%) design phase. BIA will obtain the services of a third party, VE consultant to provide Value Engineering analysis and report. The Design Team will be responsible for preparing a report summarizing the workshop from an architectural and engineering perspective. Final Design Developments (40%) documents will need to incorporate BIA accepted VE recommendations.

**2030-1. Introduction**

1.1. This section presents the requirements for submitting design calculations.

**2030-2. Format**

2.1. Design analysis information shall be organized into bound volumes of 8½ inches by 11 inches or 11-inch-by-17-inch-format sheets. All 11-inch-by-17-inch sheets are to be folded to 8½-inch-by-11-inch size.

**2030-3. Organization**

3.1. Volumes for design analysis are to be bound in a clear sequential order. Each volume shall have a cover indicating project name, project number, discipline, and the date of issuance. Each page shall include the design analysis performed, discipline, and page number. Provide a table of contents for all design analysis volumes that organizes the material into the various disciplines.

**2030-4. Design Calculations****4.1. Structural**

- 4.1.1. Calculations shall be performed for all structural systems, components, connections, and details.
- 4.1.2. When computer software is used to perform structural design calculations, include all input and output data, not just representative data.
- 4.1.3. Structural calculations shall be organized into categories. Possible categories include:
- Design parameters
  - Foundations
  - Floor systems
  - Roof systems
  - Columns
  - Wall systems
  - Lateral analysis
  - Miscellaneous structures

**4.2. Mechanical**

- 4.2.1. Mechanical analyses shall include:
- Heating/cooling loads
  - Building utilities pipe sizing
  - Plumbing fixture counts
  - Piping stress calculations for hot water systems (operating temperatures over 150°F)

- Seismic calculation as required
- Water treatment tests and evaluations
- Acoustical evaluations and recommendations for rotating equipment and distribution systems
- Other calculations required in this handbook

#### **4.3. Electrical**

##### **4.3.1. Electrical analyses shall include:**

- Lighting levels as noted in the lighting sections (text height on submitted lighting level plans shall be 8-point or 1/16-inch, minimum)
- Voltage drop
- Demand loads; include diversification per the National Electrical Code (NEC)
- Available short-circuit ampacity
- Coordination study

#### **4.4. Fire Protection**

##### **4.4.1. Fire protection analysis shall include:**

- Fire entry size and flow

**2040-1. Computer-Aided Design and Drafting (CADD) Standards**

- 1.1. Drawings for all new BIA Justice/Detention facilities must be produced to consistent CADD standards using the software and version acceptable by BIA when the Statement of Work is approved. The drawing formats, fonts, layouts, line weights, layer conventions, file naming, sheet naming, and all other symbology are to follow the procedures outlined in the A/E/C CADD Standard manual unless specifically stated otherwise. It is the responsibility of all parties producing drawing information to abide by the approved standards. Electronic files shall be clean, clearly organized, and free of all extraneous drawing information. Multiple tabs for sheets within a single CADD file are not acceptable; each drawing sheet must be a separate file.

**2040-2. Drawing Organization**

- 2.1. Drawing volumes will be limited to 99 sheets. If a project requires more than 99 sheets, the set shall be broken into additional volumes at logical delineation points; however, drawings for any single discipline shall not be divided between two volumes. Sequencing, sheet names, and arrangement shall follow the guidelines in the A/E/C CADD Standard manual. Unnecessary white space is to be avoided and the information shown must be applicable to the project and organized in a logical and clear manner.

**2040-3. Drawing Format**

- 3.1. All production drawing sets are to be placed on a size acceptable by BIA when the Statement of Work is approved. Designers are to use the standard BIA Justice / Detention Center Design border on all sheets, which will be provided by the BIA Contracting Officer along with associated project numbers and project names. Sheet titles shall clearly define the contents of each sheet, and title block information at each submittal must be as complete as possible. Dimensions on all drawings are to be in imperial units.

**2040-4. Drawing Scales**

- 4.1. Provide drawings at scales consistent with industry standards and large enough to clearly convey drawing information. Scaling conventions are to follow those presented in the A/E/C CADD Standard manual, and all drawing scales must be clearly stated (not simply shown graphically). The scale for plans must be 1/8 inch equals 1 foot 0 inches or greater. If the plan is too large to fit on the required sheet size in one piece at the required scale, the Designer of Record is to break the plan at a logical point and provide a key plan for ease of navigation. When floor plans are segmented onto separate sheets, an overall plan at a smaller scale must be provided showing the entire plan with clearly readable match lines.

**2040-5. Drawing Referencing**

- 5.1. All cross-references within a drawing set are to be based upon the sheet reference number. Enlarged drawing information must have back-references

indicating the drawing from which the detail originates. Proper back-referencing should refer the reviewer to the original location of the detail in the drawing set.

**2040-6. Location of Project Elements**

- 6.1. All floor plans and enlarged plans shall include room numbers and must be present for each relevant discipline. Designs that require structural grids must show the grid on all plans as well as on details and sections where the grid is applicable. Sheets that include plan information of any kind shall include a north arrow.

**2040-7. Seals and Signatures**

- 7.1. For documents produced by the Designer of Record and by all engineering disciplines, drawings issued at the 100 percent construction documents phase shall include a current professional seal and signature.

**2040-8. Drawing Amendments and Revisions**

- 8.1. Revisions made to existing drawings shall be shown in clouds and flagged with a revision delta. Layers for revisions should be created that correspond to the revision delta number so that changes can easily be associated with the correct drawing revision package. Earlier revision layers can be turned off, leaving only the current changes highlighted. Revision clouds should encircle only the relevant information, and the revision delta should be placed in a logical and easily read location.
- 8.2. In the event an entire sheet is added, the index drawings shall be modified with clouds and revision deltas identifying the new sheet. The new sheet itself shall have a revision cloud and delta around the sheet number and title.
- 8.3. When reissuing or replacing an entire sheet, the Designer of Record shall show the sheet number and title in a cloud and provide a revision delta.

**2040-9. Supplemental Drawings**

- 9.1. Occasionally the Designer of Record will need to issue a supplemental drawing to execute a change or provide clarification to the contractor. Supplemental drawings shall be numbered sequentially and a log shall be kept by the Designer of Record that tracks the supplemental drawing number, date, content, and reason for issuance. Provide cross-referencing on the supplemental drawing showing the original sheet and detail location of the information being modified. If the detail is new, provide a cross-reference to the location where the new information will be located in the drawing set. All supplemental drawings must be drawn to an industry standard size and must be clear and legible. The Designer of Record shall assign a prefix for each discipline to the drawing number so the contractor will know who issued the drawing. As an example, architectural supplemental drawings would be designated ASD-#, and structural supplemental drawings would be designated SSD-#.

**2040-10. Record Drawings**

- 10.1.** Record drawings are to be prepared by the Designer of Record and all of their consultants matching the contractor's as-built conditions of the facility. The record drawings are to be provided in the same CADD software and version used for construction documents. Each sheet file shall be provided with all references bound such that when the drawing is open, no additional reference pathing is required. The Designer of Record shall include all model and background files. The drawings shall be clear of all revision clouds and deltas. All previous information in the issue record index shall be removed, and the new title "RECORD DRAWINGS" shall be added with the date of record drawing issuance. The Designer of Record shall provide one full-size set of record drawings to the BIA, as well as a CD, labeled in a professional manner, containing the electronic drawings.

**2050-1. General**

- 1.1. The Designer of Record shall produce as part of each submittal package a set of specifications addressing minimum quality and performance standards, execution, product information, and technical or construction requirements. Produce specifications tailored to requirements of the project.
- 1.2. Project specifications for all design disciplines are to be written using a commercially published master specification product or system that will result in a substantially coordinated and internally consistent project specification. Address particular requirements of the project. “Boiler-plate” or “generic” specifications will not be accepted.

**2050-2. Format**

- 2.1. Specifications shall be bound in an 8½-inch-by-11-inch book with the project name, project number, table of contents with page numbers for each section, and date clearly identified. Follow format guidelines; Construction Specifications Institute’s Section and Page Format, and Masterformat; most recent editions. Each section in the specifications shall have a heading that shows the section number and the section title. Provide footer on every page that includes the date of issue, project number, project name, and page number. Format numbering to include section number before page number.

**2050-3. Coordination**

- 3.1. Specifications must complement information presented on drawings. The Designer of Record must review and coordinate documents and the efforts of their consultants to ensure that information is not missing, conflicting, or ambiguous. Information provided by the BIA shall be incorporated into the specifications as directed. Any cross-referencing between specifications sections and between specifications and drawings must be checked and coordinated prior to any submittal.

**2050-4. Proprietary Specifications**

- 4.1. “Brand” or “sole source” products and materials may not be specified. Specifications shall be written that outline a performance level or salient product characteristics that can be met or exceeded by multiple manufacturers. The Designer of Record shall not specify materials and products whose qualities are sufficiently unique that only one product will satisfy the requirements.

**2050-5. Record Specifications**

- 5.1. Record specifications are to be prepared by the Designer of Record and all of their consultants matching the contractor’s as-built information. The record specifications are to be provided in the latest version of Microsoft Word. The specifications shall be clear of all comments and revision marks. The Designer of Record shall provide one set of record specifications to the BIA, as well as a CD, labeled in a professional manner, containing the electronic information.

**2060-1. General**

- 1.1. Cost estimates shall be prepared and submitted as set forth in the Designer of Record's contract and in Section 2010 of this handbook.

**2060-2. Basic Estimates and Their Use**

- 2.1. Base estimates on the best cost data available, adjusted for the project location, and include an escalation factor for the projected midpoint of construction.
  - 2.1.1. The cost estimate will be used as a guide by the BIA in determining if the bids received are fair and reasonable.

**2060-3. Special Cost Considerations for Indian Reservations**

- 3.1. Research local conditions for each project to determine what factors (if any) should be used to customize the cost estimate to reflect local bidding conditions at the time of the bid. Construction costs on Indian reservations are impacted by numerous factors that do not normally apply in other areas. Examples of special impact factors include:
  - 3.1.1. **TERO Tax.** Obtain current Tribal Employment Rights Office TERO requirements for each project and add them to the overall project cost.
  - 3.1.2. **Davis-Bacon Wage Rates.** Current published rates should be compared to the Designer of Record's estimate database. Any increase due to higher prevailing wage rates should be added to the estimate.
  - 3.1.3. **State Tax.** Evaluate state tax requirements and include them in the estimate as appropriate.

**2060-4. Format**

- 4.1. The format of the cost estimates shall be as described below and as set forth in the Designer of Record's contract and in Section 2010 of this handbook.
  - 4.1.1. Costs for all site- and building-related costs shall be organized using the Construction Specifications Institute (CSI) *MasterFormat* numbering system.
  - 4.1.2. Provide a separate cost estimate for each building involved in the project as if it were to be bid individually.
  - 4.1.3. Provide a separate cost estimate for each alternative involved in the project.
- 4.2. **Predesign Submittal Format**
  - 4.2.1. **Building Construction Cost.** Use historical data such as that published in *Means Square Foot Costs* or similar sources. Provide the source of cost information.
  - 4.2.2. **Site and Civil Costs.** Provide a unit cost breakdown for each specific area of work. Include measured units, cost per unit, and total cost.



**4.2.3. *Cost Summary.*** Provide a cover sheet that summarizes all costs, special cost impacts, and escalation to the midpoint of construction.

**4.3. 20 Percent Schematic Design, 40 Percent Design Development, 70 Percent Preliminary Construction Documents, and 99 Percent Completed Construction Documents Submittal Format**

**4.3.1. *Building Construction Cost.*** Provide a detailed materials take-off estimate for all building components. Provide both a material and labor cost for each item. Use equipment costs where appropriate. Use of lump sum or square foot costs is not acceptable.

**4.3.2. *Site and Civil Costs.*** Provide the same information as required for building costs.

**4.3.3. *Cost Summary.*** Provide a cover sheet that summarizes all costs, special cost impacts, and escalation to the midpoint of construction.

**SAMPLE CONSTRUCTION COST ESTIMATE SUMMARY FORMAT**

**Project Name:**  
**Project Location:**  
**BIA Project Number:**

**Prepared by:**  
**Date Prepared:**  
**Bid Date:**

**Project Description: (including building area, number of stories, type of construction, and type of use)**

| CSI  | Summary Description                     | Mat'l | Labor | Total | Cost/S.F. | % of Total |
|------|---|-------|-------|-------|-----------|------------|
| 1.0  | Special and General Conditions          |       |       |       |           |            |
| 2.0  | Site Work and Demolition                |       |       |       |           |            |
| 3.0  | Concrete                                |       |       |       |           |            |
| 4.0  | Masonry                                 |       |       |       |           |            |
| 5.0  | Metal                                   |       |       |       |           |            |
| 6.0  | Carpentry                               |       |       |       |           |            |
| 7.0  | Thermal & Moisture Protection           |       |       |       |           |            |
| 8.0  | Doors & Windows                         |       |       |       |           |            |
| 9.0  | Finishes                                |       |       |       |           |            |
| 10.0 | Specialties                             |       |       |       |           |            |
| 11.0 | Equipment                               |       |       |       |           |            |
| 12.0 | Furnishings                             |       |       |       |           |            |
| 13.0 | Special Construction                    |       |       |       |           |            |
| 14.0 | Conveying Systems                       |       |       |       |           |            |
| 15.1 | Plumbing                                |       |       |       |           |            |
| 15.2 | Heating, Ventilating & Air Conditioning |       |       |       |           |            |
| 16.0 | Electrical                              |       |       |       |           |            |
|      | SUBTOTAL                                |       |       |       |           |            |
|      | Special Conditions *                    |       |       |       |           |            |
|      | SUBTOTAL                                |       |       |       |           |            |
|      | General Contractor's Overhead<br>___%   |       |       |       |           |            |
|      | General Contractor's Profit<br>___%     |       |       |       |           |            |
|      | SUBTOTAL                                |       |       |       |           |            |
|      | Escalation                              |       |       |       |           |            |
|      | TOTAL                                   |       |       |       |           |            |

**3000-1. Introduction**

- 1.1. This section presents guidelines and recommendations for incorporating sustainable design into BIA Justice / Detention projects. These guidelines and recommendations support the overall goal of designing, building, and operating high-performance buildings. Sustainable design building practices can substantially reduce or eliminate negative environmental impacts in new buildings; they also reduce operating costs, enhance building longevity, and reduce potential health problems resulting from poor indoor air quality.
- 1.2. These recommendations are based on the U.S. Green Building Council's (USGBC) Leadership in Energy and Environmental Design LEED Reference Guide for Green Building Design and Construction for the Design, Construction, and Major Renovation of Commercial and Institutional Buildings, 2009 Edition, otherwise referred to in this handbook as LEED-NC.

**3010-1. General**

- 1.1. It is the explicit goal of the Bureau of Indian Affairs to apply LEED-NC guidelines to the design of all justice/detention facilities governed by the standards in this handbook. It is required that these facilities be formally certified under LEED-NC to a rating of Silver.
- 1.2. The Designer of Record is required to obtain the most recent applicable version of LEED-NC from the U.S. Green Building Council ([www.usgbc.org](http://www.usgbc.org)). The Designer of Record is required to compile sufficient documentation to support the design of the project to the specified level of certification, according to the LEED-NC submission requirements.
- 1.3. The design team members, under the direction of the team's designated LEED manager, are required to coordinate with the contractor and the BIA to produce all documentation required by the certification program to support the LEED points being pursued on a particular project. This documentation is considered a project deliverable to the BIA as part of the requirements for project deliverables under the terms and conditions of the design contract.

**3020-1. Working with the LEED-NC Rating System**

- 1.1. The specific credits in the LEED-NC rating system provide guidelines for the sustainable design and construction of buildings of all sizes. Confirm credits with most recent version. LEED-NC includes the following general categories:
  1. Sustainable Sites (SS)
  2. Water Efficiency (WE)
  3. Energy and Atmosphere (EA)
  4. Materials and Resources (MR)
  5. Indoor Environmental Quality (EQ)
  6. Innovation in Design (ID)
  7. Regional Priority (RP)
- 1.2. While it is recognized that specific site and regional climatic conditions will influence the design of each facility in differing ways, the available credits in the rating system may be applied in any combination that will result in the specified rating. However, it is strongly recommended that priority consideration be given to those credits that address energy efficiency/performance and conservation of natural/sustainable resources. These credits are generally included in credit categories 2, 3, and 4 above.
- 1.3. It is also important to recognize that there may be more than a single credit or category that supports the whole-building approach to achieving a particular LEED-NC credit point. For example, in order to achieve maximum energy performance and efficiency of the HVAC system (and, thus, the entire building), it may be necessary to specify certain materials, building envelope systems, and lighting systems, etc., to further enhance and improve an otherwise “efficient” HVAC system. Every consideration should be given to viewing the entire facility design as an integrated whole when developing strategies to achieve maximum energy efficiency/performance and conservation of natural/sustainable resources.
- 1.4. Finally, it is required that each BIA justice/detention facility project complies with minimum program requirements and prerequisites specified in the various credit categories of LEED-NC rating system, most recent version. These minimum program requirements and prerequisites represent fundamental requirements of sustainable design, and must be given the highest level of priority and consideration.

**4000-1. Introduction**

- 1.1. This chapter shall be used as a guideline in the development and design of all new BIA Justice/Detention facility sites. This shall encompass all outdoor areas, including vehicular and pedestrian areas. The design shall be in conformance with these guidelines unless exceptions to them are granted by the BIA.
- 1.2. Refer to Chapter 1, “General Information,” and Chapter 2, “Presentation of Data,” for required documents, drawing and specifications formats, and other design and submittal requirements not discussed in this chapter.
- 1.3. Additional design and submittal requirements may be required for projects with unusual or highly technical criteria.
- 1.4. As applicable, the Designer of Record shall incorporate the sustainability strategies identified in Chapter 3, “LEED Goals and Guidelines.”
- 1.5. The guidelines in this chapter should be used in conjunction with those in the other chapters in this handbook, and the Designer of Record should coordinate with the other project consultants to be sure all aspects of the justice/detention facility are effective and compatible. Coordination between the architect, the civil engineer, and the landscape architect is required.
- 1.6. All design features must be weighed carefully for their initial cost, long-term maintenance cost and needs, durability, and their impact on the environment.

**4010-1. General**

- 1.1. For site design, follow all current applicable codes, standards, and laws. For a more general list of codes and standards that apply to BIA Justice/Detention facilities, refer to Chapter 1, “General Information.” During design, report any required deviations from codes and standards to the Contracting Officer.
- 1.2. Where two codes, standards, or laws are applicable to the topic under review, use the more conservative or more stringent. Consult with the BIA Office of Facilities Management and Construction (OFMC) to resolve any questions or conflicts regarding application of codes and standards.

**4010-2. Applicable Codes and Standards**

- 2.1. The design criteria shall comply with the guidelines published by or contained in the following:
  - *National Best Practices Manual*
  - State, local, tribal, regulatory, health, and environmental agencies with jurisdictional authority for the use and development of site.

**4020-1. Introduction**

- 1.1. This section shall be used as a guideline for the site evaluation and design process for BIA Justice/Detention facility projects. During this process, the Designer of Record should coordinate with other project consultants, specifically with the civil engineer, the architect, and the landscape architect.
- 1.2. This design process will promote a clear understanding of the site design's feasibility, safety, appearance, constructability, and structural integrity.

**4020-2. Site Considerations****2.1. Land Status**

- 2.1.1. Describe the type and status of the land on which the project is to be located. Proper acquisition of the land must precede any design or construction activity.
- 2.1.2. Archaeological clearance must be obtained prior to any construction that may affect existing archaeological sites.
- 2.1.3. Determine the extent of historic preservation requirements for the project via consultation with the Contracting Officer and area office facility manager.

**2.2. Efficiency/Economy**

- 2.2.1. Select and design materials, systems, and components appropriate to the project requirements.
- 2.2.2. Recognize and respect the existing site features and preserve and/or enhance them to the greatest extent possible.
- 2.2.3. Design systems so as to minimize short- and long-term maintenance.
- 2.2.4. Select environmentally sensible products and practices.

**2.3. Accessibility**

- 2.3.1. Design the site to meet all applicable requirements under the ADA and the ABA.

**2.4. Safety**

- 2.4.1. Materials selection should include consideration for potential tripping hazards; and toxic ingredients and materials.
- 2.4.2. Chemicals, materials, and equipment used for maintenance and cleaning activities should be stored in secure locations per all applicable codes and laws.
- 2.4.3. Consider security and safety in site design and layout. In the preliminary stages of design, discussions should occur between the design team and the BIA representatives to determine the level of security desired and needed based on the level of threat. Site designs should consider



controlled access, maintaining appropriate clear zones, minimizing blind spots, visibility of approaches, nonlinear vehicular approaches to main entry points, and separation between pedestrian and vehicular zones.

- 2.4.4. Incorporate safety and security features as part of the site design to minimize their appearance as much as possible. Topography, vegetation, water, walls, and decorative bollards can all be used as security features.

## 2.5. Durability

- 2.5.1. In choosing landscape products and plant materials for the site, consider their resilience and durability.
- 2.5.2. Choose site features that will be durable in the site's climate. Factors to consider include precipitation, wind, sun, and temperatures (as well as temperature fluctuations). Exposure to particular climatic conditions may cause certain materials to deteriorate faster than others.
- 2.5.3. When choosing a product, consider its ease of repair, restoration, replacement, or resistance to vandalism.

## 4020-3. Site Design Process

- 3.1. Site Inventory and Analysis. All sites should be assessed for all existing site conditions.
  - 3.1.1. Existing site conditions will include existing landforms, slopes, drainage channels and patterns, and other land features, as well as existing structures, existing vegetation, and existing site features such as walks, fences, above- and below-ground utilities, and parking areas (paved or unpaved).
  - 3.1.2. Conduct site inventory that documents existing weather patterns such as prevailing wind direction, amount of precipitation, and sun exposure for all seasons.
  - 3.1.3. Note and map all activities and uses that have occurred on the site, including farming, mining, drilling, storage, waste disposal, and residential / commercial uses.
  - 3.1.4. As part of site analysis, consider off-site influences, such as site access, views, and negative impacts created by off-site activities and features.
  - 3.1.5. Note other considerations that may be less apparent, such as soil types, underground water sources, and subsidence areas.
  - 3.1.6. Map and summarize all existing conditions for reference prior to preliminary site design.
- 3.2. Base information should include a site survey with elevation datum and elevation benchmarks and contour map.

- 3.3. Preliminary Site Design.** Preliminary site design typically occurs in conjunction with preliminary site programming. The program will determine, generally, the activities that will occur on-site. The development of an accurate preliminary program is key to a functional and efficient design process, especially in the preliminary phases. It provides preliminary sizing and estimates of spaces for public spaces, parking, services areas, activity areas, etc.
- 3.3.1.** Layouts should emphasize orienting buildings to minimize the effects of summer solar heat load and optimize winter solar gain. Summer prevailing breeze should also be taken advantage of, where feasible, without excessive costs for grading, roads, drainage, landscaping, or other features.
- 3.3.2.** It is imperative that the architect, landscape architect, and civil engineer coordinate the building location and orientation to optimize interior uses, exterior uses, site features and pedestrian/vehicular circulation. Buildings are the site's primary features, and their layout, location, orientation, and entry points will influence or dictate the location of public spaces, sidewalks, parking lots, driveways, and planting beds.
- 3.3.3.** Coordination between the civil engineer and the landscape architect will include addressing overall site layout, site grading, utility infrastructure (existing and proposed), storm drainage, water supply and waste water systems, access, and circulation. Refer to the other sections in this chapter and to Chapter 5, "Civil," for additional requirements for site design.
- 3.3.4.** Consider the impact of new construction on existing facilities.
- 3.3.5.** Consider areas for future building or site amenities expansion.
- 3.3.6.** Meet the requirements for flood protection.
- 3.4. Final Site Design.** The final portion of the site design process includes everything from a final concept plan through final construction documents. These documents should include final building locations, utilities, and access and circulation routes. The program for these documents should also be finalized, including all numbers and uses for the site.
- 3.4.1.** Site and landscape plans should include accurate representations of all products and site features as noted in all sections of this chapter.
- 3.4.2.** Coordination among the civil engineer, architect, and landscape architect should occur at every step of this stage of the process. Changes in grades, access points, circulation patterns, entry points, and uses will affect the site and landscape designs.
- 3.4.3.** Coordination between the civil engineer and landscape architect should occur for all grading. There should be close coordination in the final fine grading of bed, landscape, and hardscape areas.
- 3.4.4.** The final grading design should create landforms that appear natural, with smooth transitions to existing grades.

- 3.4.5. A plant palette, including trees, shrubs, ornamental grasses, perennials, annuals, vines, and seed mixes should be nearly finalized at the final concept plan, but should be complete and all plants labeled for the final construction documents.
- 3.4.6. Site furniture, hard surface materials, wall materials, and all other site materials should be a consideration at the time of the final concept plan; however, all materials should be finalized during the Construction Documents process and included in the final construction documents.
- 3.4.7. Where emergency access routes around the buildings are required, minimize their visual and physical impact by incorporating them into the walkways, hard surface play areas, and site features where possible.

**4030-1. General**

- 1.1. The site design should carefully consider access and circulation routes for pedestrians and vehicles. The design should incorporate separate routes for visitors, staff, and offender transport vehicles, minimizing conflicts between users whenever possible.

**4030-2. Vehicular Circulation**

- 2.1. Vehicular circulation routes should be clear and simple in order to prevent driver confusion when accessing the site. Maintain separation between visitors, staff, and offender transport vehicles on the site.
- 2.2. Entry areas for various types of vehicular traffic should be clearly marked. If conditions and safety concerns allow, there should be a minimum of two driveways for vehicular access into the site (one for visitor, staff and service, one for transportation of offenders). If a single access is preferred or required, separation should occur as soon as possible within the site.

**2.3. Offender Drop-Off/Pickup Driveway**

- 2.3.1. Design the offender drop-off/pickup area to be separated and secured from visitor and staff vehicle circulation.
- 2.3.2. Maintain one-way traffic circulation to and from sally port.
- 2.3.3. Locate the sally port near detention arrest processing intake/release and courts, while providing a secured separation between the public, staff, and service entry and circulation. Provide 8 feet high fence or wall for secured separation.
- 2.3.4. Locate vehicle circulation to avoid overhead obstructions of building. If vehicle fence gates require overhead obstructions, coordinate minimum clearances required for largest vehicles that will serve the facility.
- 2.3.5. Vehicles should not be required to back up while on the site.
- 2.3.6. Access drives are to be a minimum of 24 feet in width.
- 2.3.7. Design access drives for bus turning; minimum of 35 feet for interior radii and minimum of 50 feet for outer curve radii.
- 2.3.8. Design heavy-duty pavement for drives, loading areas, and parking areas used by buses, trucks, and other heavy vehicles.

**2.4. Visitor Parking**

- 2.4.1. Locate visitor parking near the main building entrance, close to the administration offices and courts, while still providing a visibility barrier between the vehicular and pedestrian uses. Typical visual barrier treatments may include distance, topography, vegetation, seat walls, planting beds, decorative bollards, or boulders. Visibility from the

building through and to the visitor parking area should not be greatly reduced by the use of visual barriers.

- 2.4.2. Parking space dimensions are a minimum of 9 feet by 18 feet, with 24-foot-wide aisles.
- 2.4.3. Accessible parking spaces should be provided as required per ABAAG requirements.
- 2.4.4. Coordinate with the BIA for the number of parking spaces needed based on student population, expected visitor use, and potential community uses.

## 2.5. Staff Parking

- 2.5.1. Provide one parking space for each staff member, including spaces for part-time staff and student teachers.
- 2.5.2. Provide a minimum of four parking spaces near the delivery/receiving area for food service and custodial staff.
- 2.5.3. Locate staff parking near visitor parking for economy of pavement design where possible. Staff parking can also be located to one side of the bus parking lot in the area not required for bus traffic.
- 2.5.4. Secure Law Enforcement parking areas with fencing. Ready line vehicles may be parked outside of secured area if approved by BIA.
- 2.5.5. Parking space dimensions are a minimum of 9 feet by 18 feet, with 24-foot-wide aisles.

## 2.6. Impound Vehicle Storage Lot

- 2.6.1. Provide parking spaces based on program requirements.
- 2.6.2. Secure evidence storage areas with fencing. Locate away from public building entrances. Visually separate evidence storage areas from public circulations routes with building, topography, or vegetation.
- 2.6.3. Parking space dimensions are a minimum of 9 feet by 18 feet, with 24-foot-wide aisles.

## 2.7. Accessible Parking Spaces

- 2.7.1. Comply with BIA requirements and with the ABAAG accessibility requirements; all three supersede any standards listed in this document if different.
- 2.7.2. Provide a minimum of one accessible parking space or 2 percent of the total number of parking spaces in each parking lot (whichever is greater).
- 2.7.3. Locate these parking spaces on the shortest accessible route of travel to an accessible building entrance.
- 2.7.4. Where possible, accessible pedestrian routes should not cross drives or vehicular parking areas. If necessary, provide crosswalks painted on the

pavement and signs to designate pedestrian rights-of-way. Raised pavement for crosswalks may also be considered.

### **2.8. Perimeter Curbs**

- 2.8.1.** Provide 6-inch-high curb to separate car and pedestrian circulation routes.
- 2.8.2.** Locate curbs as required to direct the flow of storm water toward storm sewer inlets.
- 2.8.3.** Provide curbs at planted islands in parking lots.
- 2.8.4.** Provide curbs along drives and adjacent to storm detention ponds or other abrupt slopes adjacent to the drive.
- 2.8.5.** If there are no curbs, provide wheel stops where parking is perpendicular to the edge of the pavement. Do not locate wheel stops along curbs, unless they are used restrict vehicle overhang along walks. Provide wheel stops made from recycled material whenever possible.
- 2.8.6.** Where a curb separates perpendicular parking and pedestrian circulation walkways, increase the walk width to accommodate bumper overhang at walk or provide wheel stops to restrict vehicle overhang along walks. No walk should have less than 5 feet clear width when cars are parked perpendicular to walk when wheels are against curb or wheel stop.
- 2.8.7.** Straight curb or curb and gutter may be used to separate car and pedestrian circulation routes.

**4040-1. Emergency Vehicle Access and Circulation**

- 1.1. Review emergency vehicle access and circulation construction with jurisdictional authorities.
- 1.2. When possible, walks or paths should accommodate emergency vehicles around the perimeter of buildings where vehicular drives are not present.
- 1.3. Where emergency access routes around the buildings are required, minimize their visual and physical impact.
- 1.4. Provide removable or hinged bollards or a breakthrough gate at the end of the emergency access path where it meets vehicular drives to prevent use of the path by nonemergency vehicles. Space bollards a minimum of 5 feet on center.

**4050-1. General**

- 1.1. Service areas may occur in various locations on the site, including adjacent to main buildings as well as at independent locations. No service areas should be located at primary entry points or at the front of buildings. Typically, service areas provide access for kitchen and building maintenance staff, trash and recycling facilities, delivery drop-off, and other functions that provide valuable services to the faculty and staff but which are typically unseen or minimally visible.
- 1.2. Additional screening, such as walls or landscape, can be used to reduce the visual impact of the service areas on other areas of the site and adjacent properties.

**4050-2. Service Drives**

- 2.1. Service drives should, where possible, have a separate access drive into the site. Where an access point is restricted, include it with the driveway serving staff parking or evidence storage parking.
- 2.2. Service areas should be minimally apparent and not easily accessible to the public. If additional security is required or desired, a gate could be used. Other operational solutions may include defining delivery and service hours or restricting access to qualified companies or individuals with pass cards.
- 2.3. Provide a T-turn with a minimum 5-foot radius for maneuvering large trucks in all delivery/receiving areas.

**4050-3. Service Dock**

- 3.1. Provide service dock for food and supply deliveries to kitchen. The service dock may provide shared access to maintenance facilities if plan allows.
- 3.2. A raised service dock may be provided, depending on site conditions. Design raised dock area sloped away from dock to properly drain projected water flow away from lowest grade, without drains. Exterior raised docks cannot have any area that can accumulate water or rely on piped drainage.
- 3.3. If there is a raised service dock, provide appropriate bumpers and leveling devices to accommodate all vehicle types using the service dock. Provide a continuous angle along the concrete dock to protect the edge from chipping

**4050-4. Parking**

- 4.1. Provide a minimum of four parking spaces near the delivery/receiving area for food service and custodial staff.
  - 4.1.1. Parking space dimensions are a minimum of 9 feet by 18 feet and there should be clearance to allow vehicles to back up.



**4050-5. Trash and Recycling Facilities and Pickup**

- 5.1.** Design heavy-duty reinforced concrete pavement at trash dumpster and vehicle loading area for weight of vehicle and fully loaded dumpster. Provide steel plates or channels embedded into the concrete slab to protect the concrete from wearing due to the heavy steel rollers on the large dumpsters, if large dumpster will be used. Coordinate size and location with equipment.
- 5.2.** There should be a minimum of two Dumpsters and one recycling bin enclosure in each building's service area, even if recycling services will not be initially provided.

**4050-6. Site Maintenance Facilities**

- 6.1.** If a separate facility is required for truck and/or supply storage or a maintenance yard, this facility and the yard area should be fenced with a minimum of 8-foot-high metal or chain-link fencing.
- 6.2.** Chemical, gasoline, and oil storage areas should meet all federal, state, and local regulations for safety and security.

**4060-1. General Concepts**

- 1.1. The site design will need to integrate roads, walks, Outdoor exercise areas, turf, and landscape areas into a cohesive site plan..
- 1.2. If feasible provide surfacing to achieve a solar reflectance index (SRI) value of at least 29 to reduce the on-site heat gain on all hardscape surfaces.
- 1.3. General site security and safety features should be considered. Early coordination with the BIA representative will allow the design team to determine the level of threat and design appropriately. These preliminary discussions will assist in determining the number of access points, fencing options and requirements, separation of uses needed, and barrier requirements.

**4060-2. Walks and Paths**

- 2.1. Walks shall provide accessible routes between building exits and destination points on the site.
- 2.2. Pedestrian areas should be separated from vehicular areas by a physical barrier. This physical barrier should be integrated into the site design and not appear as a threatening separation. Typical treatments may include distance, topography, vegetation, seat walls, planting beds, decorative bollards, or boulders. Visibility from the building through and to pedestrian areas should not be greatly reduced by the use of barriers.

**2.3. Pedestrian Walks**

- 2.3.1. Provide major connecting walks, a minimum of 8 feet wide, from major drop-off drives to major entrances.
- 2.3.2. Major connecting walks at major building entrances to be a minimum of 8 feet wide.
- 2.3.3. Provide walks from the building to public walks if public walks serve the site; these are considered minor connecting walks.
- 2.3.4. Walks should be designed to a minimum of 1 percent and a maximum of 5 percent slope in the direction of traffic, and 2 percent or less for all cross-slopes. If a walk exceeds or is equal to 5 percent slope, it shall be designed as a ramp.
- 2.3.5. Walks are to be reinforced (with fiber mesh) concrete and a minimum of 4 inches thick, with a light broom finish. Asphalt or other materials shall not be used for walks.
  - 2.3.5.1. Concrete is required for all major access walks.
  - 2.3.5.2. If a walk is to be used for fire access, local jurisdictional requirements will need to be met for thickness of the concrete and width of the surface.

**4080-1. General**

- 1.1. Fencing should be used to limit or contain access to areas. Provide similar fencing throughout site.
- 1.2. Provide steel or coated wire chain link fencing.
- 1.3. Locate fencing on the curb in high-maintenance areas.
- 1.4. The top and bottom of chain-link fencing selvage shall be knuckled to prevent injury.

**4080-2. Site Perimeter Fencing**

- 2.1. In some cases, the entire perimeter can and should be fenced. This decision should be discussed with the BIA representative and based on the level of security. Consider the providing:
  - An exterior perimeter defense system consisting of site fencing, surveillance camera, and an exterior door access control system
  - Eight-foot-high chain-link fence around all or selected portions of the site with gates to control main vehicular and pedestrian access.

**4080-3. Fences Interior to the Site**

- 3.1. Provide fencing to enclose mechanical yards, equipment, trash/service areas, and where other safety hazards occur.
- 3.2. Provide eight-foot-high chain-link fencing, including law enforcement parking.
- 3.3. Provide ten-foot-high chain-link fencing around vehicle impound lot.
- 3.4. Anchor bottom of chain-link fabric to discourage access under fencing.

**4080-1. General**

- 1.1. This section provides guidelines for the Designer of Record relative to the geotechnical evaluation of the site.

**4080-2. Geotechnical Report Review**

- 2.1. The BIA will provide the Designer of Record with a project geotechnical report. The Designer of Record shall review the report and notify the BIA of any apparent deficiencies. Specifically review the report for conformance with NFPA 5000, Chapter 36, and items on the checklist below.
- 2.2. Where multiple foundation options are provided in the geotechnical report, the Designer of Record shall provide foundation recommendations to the BIA. See Section 9030-4.

**4080-3. Geotechnical Report Checklist**

- 3.1. In addition to the above, the Designer of Record shall confirm that the following have been addressed in the report where applicable. If the report is deficient, the BIA shall be notified.
  - The site topography is described and all the topographic features and surface water noted that may affect the project.
  - Existing structures or pavements on the site are described, if applicable.
  - Subsurface obstructions, mine shafts, or tunnels are identified and described, if applicable.
  - The results of the subsurface investigation and all laboratory testing and their impacts on the proposed construction are described.
  - Logs of all borings and test pits and results of all laboratory tests as applicable, including soil classification, liquid limit, plastic limit, plasticity index, pH, resistivity, shrink/swell tests, radon, and salinity are included.
  - A contour map of the bedrock surface is included, if applicable.
  - The geotechnical engineer's understanding of the proposed structure(s), including type of construction contemplated, size and height, finished floor elevation, and elevation relative to existing ground elevation is presented and described.
  - Foundation recommendations and design parameters are provided, and the movement potential of each system is quantified.
  - Design criteria are provided for resisting building lateral loads, including laterally loaded piers, soil frictional characteristics, or battered piles, as applicable.
  - Solutions are provided for constructing on expansive soils, as applicable.

- Site seismic information is provided, including soil site class, liquefaction potential, and surface rupture, if applicable.
- Design recommendations regarding slope stability are provided, as applicable.
- Information is presented on water tables as they affect construction and the completed building.
- Lateral design pressures are provided for foundation-wall design and retaining-wall design.
- Footing design parameters for retaining walls are provided.
- Existing fill, if any, is described and information provided on whether the fill must be removed or reworked.
- Recommendations for slab-on-grade or structural floors on grade are provided.
- Voiding requirements, if any, under foundation elements are provided.
- Soil compaction requirements are provided.
- Recommendations for type of cement, minimum air content, maximum water/cement ratio, and minimum strength for concrete elements in contact with soils are provided.
- Information is provided relative to radon and mitigation measures recommended to ensure radon levels in the completed building will not exceed code limits.
- Recommendations for frost heave prevention are provided.
- Excavation and earthwork requirements are provided.
- Vehicular pavement requirements and recommendations are included.
- Perimeter drain and underdrain requirements and details are included as applicable.
- Earth liner recommendations are provided, if applicable.

**5000-1. Introduction**

- 1.1. This chapter shall be used as a guideline in the development of the site grading, earthwork, utility infrastructure, drainage, water and wastewater systems, paving, and roads for all new BIA Justice / Detention facility projects. Design for all new construction for the BIA shall conform to the guidelines outlined herein, unless exceptions to them are granted by the BIA.
- 1.2. Refer to Chapter 1, “General Information,” and Chapter 2, “Presentation of Data,” for required documents, drawing and specifications formats, and other design and submittal requirements not discussed in this chapter. All documents must meet professional engineering standards and be stamped by the appropriate professional engineer.
- 1.3. Additional design and submittal requirements may apply for projects with unusual or highly technical criteria.
- 1.4. As applicable, the Designer of Record shall incorporate the sustainability strategies identified in Chapter 3, “LEED Goals and Guidelines.”
- 1.5. The guidelines in this chapter should be used in conjunction with those in the other chapters in this handbook, and the Designer of Record should coordinate with the other project consultants to be sure all aspects of the Justice / Detention facility are effective and compatible.
- 1.6. All design features must be weighed carefully for their initial cost, long-term maintenance cost and needs, durability, and their impact on the environment.

**5000-2. Quality Control**

- 2.1. Quality control shall include, but not be limited to, completing the checklist that appears on the following pages. The criteria in the checklist include all parts of the design outline and should be considered prior to submittal. Verify that the design complies with the design guideline requirements.

**Figure 5000-1: General Quality Control Civil Engineering Checklist**

|   |                            |
|---|----------------------------|
| <b>Project Name:</b>                    | <b>Sheet No.:</b>          |
| <b>Job No.:</b>                         | <b>Page _____ of _____</b> |
| (EPR) Engineering plan reviewed by:     | Date:                      |
| (CPR) CAD plan reviewed by:             | Date:                      |
| (CEFR) CAD electronic file reviewed by: | Date:                      |
| (PIC) Principal in charge review:       | Date:                      |
| (NR) Not required, (REQ) Required       |                            |

|  | REQ | NR | EPR | CPR | CEFR |
|--|-----|----|-----|-----|------|
| Sheet elements (e.g., north arrow, dates, scales, etc.)  |     |    |     |     |      |
| Jurisdictional general notes (verify current version)  |     |    |     |     |      |
| Designer of Record's general notes   |     |    |     |     |      |
| Note abbreviations used  |     |    |     |     |      |
| Note stating contractor to verify existing site conditions and to notify owner and engineer of any discrepancies |     |    |     |     |      |
| Key map matches plan   |     |    |     |     |      |
| Match lines match referenced sheets  |     |    |     |     |      |
| References to other sheets accurate  |     |    |     |     |      |
| Basis of bearings  |     |    |     |     |      |
| Benchmark  |     |    |     |     |      |
| Boundary lines on and labeled  |     |    |     |     |      |
| Street names labeled correctly   |     |    |     |     |      |
| Existing and proposed surface features (buildings, walls, walks, curbs, etc.) shown and labeled                  |     |    |     |     |      |
| Demolition plans labeled   |     |    |     |     |      |
| Existing and proposed contours shown and labeled   |     |    |     |     |      |
| Existing rights-of-way and easements labeled per title work  |     |    |     |     |      |
| Existing utilities shown and labeled   |     |    |     |     |      |
| Proposed storm sewer system shown and labeled  |     |    |     |     |      |
| Storm profiles verified  |     |    |     |     |      |
| Proposed sanitary sewer system shown and labeled   |     |    |     |     |      |

CHAPTER 5: CIVIL

|  | REQ | NR | EPR | CPR | CEFR |
|--|-----|----|-----|-----|------|
| Proposed sanitary profile verified   |     |    |     |     |      |
| Proposed water system shown and labeled  |     |    |     |     |      |
| Proposed water profile verified  |     |    |     |     |      |
| Adjacent sites labeled   |     |    |     |     |      |
| Blowup of area around building provided (minimum scale of 1"=20')  |     |    |     |     |      |
| Earthwork cut/fill analysis if requested by client<br>Total site cut_____yds.;<br>Fill % compaction_____ yds.<br>Total site _____import/export with a ___% shrink/swell factor |     |    |     |     |      |
| Check cross sections or use other means to verify earthwork quantities (e.g., +/- on grid)   |     |    |     |     |      |
| If placed on plan, reference geotechnical information  |     |    |     |     |      |
| If grades are above finished floor of building, discuss with architect and structural engineer   |     |    |     |     |      |
| Snow removal/storage areas provided  |     |    |     |     |      |
| Erosion control and SWMP   |     |    |     |     |      |
| Horizontal layout  |     |    |     |     |      |
| Construction details   |     |    |     |     |      |
| Construction documents specifications  |     |    |     |     |      |
| Utilities: gas and electric shown  |     |    |     |     |      |



**5000-3. Site Type**

- 3.1. Each location presents various factors that must be incorporated into the design process. Verify that the following have been considered:
- Historical features that must be preserved
  - Local ordinances pertaining to site design
  - Local tribe mandates varying from BIA regulations
  - Land availability
  - Layout/site features
  - Weather
  - Geotechnical studies
  - Traffic evaluations
  - Existing landscape versus proposed landscape constraints

**5000-4. Local Availability**

- 4.1. Verify local availability of spare parts, replacement parts, and service technicians for future maintenance of the equipment and materials specified.
- 4.2. If equipment is not locally available, determine how long it will take to acquire and verify with the BIA that this time is acceptable.

**5000-5. Warranty**

- 5.1. All systems shall have a minimum 1-year warranty from date of substantial completion.
- 5.2. Labor warranty shall be performed by factory-trained service technicians located within 50 miles of the project site, or a distance as appropriate to the site.

**5010-1. General**

- 1.1. System integration will influence the criteria needed for each design depending on the constraints specific to each project. All systems are subject to BIA approval, and other systems may be available that are not delineated within this chapter.

**5010-2. Civil Systems**

- 2.1. General civil systems include the following: streets and roadways, parking and drives, site grading, erosion and sediment control, water systems, sanitary systems, and drainage systems.
- 2.2. The following factors should be considered when evaluating a civil system:
  - Overall initial cost, including materials costs, transportation costs, and labor costs. Maintenance costs should also be considered.
  - Constructability, including the construction schedule, phasing, simplicity, and the number of trades needed to complete the project.
  - Performance of the system and overall integration with all other systems being used.
  - Local as well as outside availability of materials needed.
  - Local expertise, including experience and understanding of the project scope as well as knowledge of construction materials.
  - The need for post-construction maintenance of the system, as well as local expertise in that maintenance.
  - Life cycle of the construction project. The construction season will vary from site to site; shorter seasons may either limit the project scope or encourage efficient construction techniques. These may include prefabricated or premanufactured systems that may be implemented during colder months.
  - Future modifications, including geotechnical settling and compaction, water supply variances, and overall system flexibility and expandability.
  - LEED compliance in all pertinent areas, in order to maximize LEED points. See Chapter 3 for LEED certification requirements.
  - Site layout, including both existing and proposed site configurations and features.
- 2.3. All engineering disciplines involved in the design and construction of BIA Justice / Detention facilities should coordinate their approaches and systems to ensure alignment of design. Preapproved systems should be given priority, and efficiency as well as cost-effectiveness should influence system choices.

**5020-1. General**

- 1.1. Follow all current codes, standards, and laws as they apply to each civil engineering discipline within the design. For a more general list of codes and standards that apply to BIA Justice / Detention facilities, refer to Chapter 1, "General Information." During design, report any required deviations from codes and standards to the Contracting Officer.
- 1.2. Where two codes, standards, or laws are applicable to the civil topic under review, use the more conservative or more stringent. Consult with the BIA Office of Facilities Management and Construction (OFMC) to resolve any questions or conflicts regarding codes and standards.

**5020-2. Applicable Codes and Standards**

- 2.1. The design criteria shall comply with the guidelines published by or contained in the following:

**2.1.1. National Fire Code**

- National Fire Protection Association (NFPA) National Fire Code (NFC)

**2.1.2. Civil Engineering**

- American Association of State Highway and Transportation Officials (AASHTO)
- American Concrete Institute (ACI)
- American Society of Civil Engineers (ASCE)
- Americans with Disabilities Act Accessibility Guidelines for Buildings and Facilities (ADAAG)
- Architectural Barriers Act (ABA)
- Executive Order 11988 Floodplain Management; follow guidelines relevant to civil engineering
- *Manual on Uniform Traffic Control Devices* (MUTCD)
- *Standard Specifications for Construction of Roads and Bridges on Federal Highway Projects*, United States Department of Transportation (USDOT, FHWA)
- *Urban Drainage Design Manual*, Federal Highway Administration (FHWA)

- 2.1.3. **Environmental Engineering.** As related to wastewater, solid waste, and potable water:

- American Society of Civil Engineers (ASCE)
- Clean Air Act (P.L. 88-206), as amended

- Clean Water Act (P.L. 92-500), as amended
- National Environmental Policy Act of 1969 (P.L. 91-190), as amended
- National Sanitation Foundation (NSF) standards
- Resource Conservation and Recovery Act (P.L. 94-580), as amended
- Ten-State Standards for Sewage Works
- Ten-State Standards for Water Works
- U.S. Environmental Protection Agency (EPA)
- U.S. Public Health Service, and state and local public health agencies
- Water Pollution Control Federation (WPCF)

**2.1.4. *State and Local.*** Follow applicable state and local building codes only when they exceed the requirements of the following agencies:

- American Society for Testing and Materials (ASTM)
- National Fire Protection Association (NFPA): Fire and Life Safety
- Occupational Safety & Health Administration (OSHA): 29 CFR 1910 and 1926

**5030-1. General**

1.1. This section provides criteria, requirements, and guidance for civil design and construction plans for BIA Justice / Detention facilities. Civil design shall incorporate accepted engineering practices regarding feasibility, safety, appearance, constructability, and structural integrity.

1.1.1. A complete site boundary and topographic survey depicting major site features planned, such as building orientation, drainage patterns, parking provisions, traffic circulation, provisions for the handicapped, security requirements, etc., shall be developed for the project.

1.1.2. Designs and construction may vary based upon local criteria and/or submittal processes.

1.2. **Applicable Publications**. Sustainable design concepts as presented in the following publications should be incorporated to the fullest possible extent:

- *BIA Site Selection Handbook*
- U.S. Green Building Council's *LEED-NC Reference Guide for New Construction & Major Renovations*.

**Note:** Of the potential strategies listed in Credit 6.2 – Stormwater Design: Quality Control, constructed wetlands are disallowed, unless specifically approved by the BIA, due to increased maintenance requirements associated with such installations and the need for continual preservation.

**5030-2. Site Criteria****2.1. Geotechnical Investigation**

2.1.1. Conduct a complete site geotechnical investigation for all new buildings of more than 2,000 square feet. For smaller buildings, the need for a geotechnical investigation shall be determined by the Contracting Officer on a case-by-case basis.

2.1.2. Site grading is to follow the geotechnical investigation report. The Designer of Record shall have grading drawings reviewed by the geotechnical engineer for general adherence to the soils report unless such review is not required by the BIA.

2.1.3. Avoid developing sites that are classified as prime farm land, that provide habitat for endangered or threatened species, or that are within 100 feet of any wetland.

2.1.4. No Justice / Detention facility should be located in a 100-year or a 500-year floodplain. Obtain elevations from the U.S. Army Corps of Engineers or the Federal Emergency Management Agency (FEMA).

### 5030-3. Site Grading

#### 3.1. General

- 3.1.1. Grade the site to provide positive drainage away from buildings and provide storm drains as needed. Keep waste and borrow of material to a minimum.
- 3.1.2. Consider existing site features affecting grading, such as buildings, streets, curves, walks, fences, watercourses, ponds, elevation of high water, rock outcrops, etc.
- 3.1.3. Provide flood protection for all structures, taking into account flood frequencies as defined in Section 5080, "Storm Drainage."
  - 3.1.3.1. Avoid drainage ponds within the campus area.
- 3.1.4. Consider these principle grading objectives in the early stages of design:
  - Development of attractive, suitable, and economical building sites
  - Provision of safe, convenient, and functional access to all areas for use and maintenance
  - Disposal of surface runoff from the site area without erosion or sedimentation, or its collection as needed for water features, debris basins, or irrigation storage
  - Diversion of surface and subsurface flow away from buildings and pavements to prevent undue saturation of the subgrade, which could damage structures and weaken pavements
  - Preservation of the natural character of the site by minimizing disturbance of existing ground forms and meeting satisfactory ground levels at existing trees to be saved
  - Optimum on-site balance of cut and fill; stockpiling existing topsoil suitable for reuse in landscaping
  - Avoidance of filled areas that will add to the depth or instability of building foundations and pavement subgrades
  - Avoidance of wavy profiles in streets and walks and of steps in walks
  - Avoidance of earth banks requiring costly erosion control measures, except where earth banks are needed in place of costly retaining walls
  - Keeping finished grades as high as practicable where rock will be encountered close to the surface, thus reducing the cost of utility trenching and other excavation and improving growing conditions for vegetation
  - Avoidance of runoff water over roadways to mitigate ice formation

### **3.2. Finished Floor Elevations**

- 3.2.1. Maintain the finished floor elevation of buildings above the finished street grade. Consult with the BIA before specifying any finished floor elevation below the finished street grade.
- 3.2.2. Finished grade elevation adjacent to the building should be a minimum of 12 inches below top of foundation except in areas of access to the building. Buildings should not be in the 100-year or 500-year floodplain. Finished floor elevation of all habitable structures must be built outside of and a minimum of 2 feet above the 500-year floodplain.

### **3.3. Grade Spot Elevations**

- 3.3.1. Establish and show grade spot elevations at key locations on the drawings. Indicate curb or fill requirements and rough estimates of quantities.

### **3.4. Sidewalks**

- 3.4.1. Lay out sidewalks to provide a minimum transverse slope of 1 percent across walks toward the natural drainage. Use a maximum longitudinal slope of 4.9 percent for accessible walks to avoid their classification as ramps.
- 3.4.2. Indicate sidewalk width and locations.

## **5030-4. Retaining Walls**

- 4.1. The following types of retaining walls are permitted:

### **4.1.1. *Mechanically Stabilized Earth***

- 4.1.1.1. Mechanically stabilized earth (MSE) retaining walls shall consist of a concrete modular block unit, geosynthetic soil reinforcement, backfill, and subsurface drainage.
- 4.1.1.2. The concrete modular block shall be manufactured specifically for use in an MSE wall system.
- 4.1.1.3. Geosynthetic soil reinforcement shall be a geogrid of high-density polyethylene expanded sheet or polyester woven fiber materials, specifically fabricated for use as soil reinforcement.
- 4.1.1.4. MSE retaining walls shall be specified as a performance-specified product. The contractor shall submit construction drawings and design calculations signed and sealed by a registered engineer.

### **4.1.2. *Reinforced Concrete Retaining Walls***

- 4.1.2.1. Reinforced concrete retaining walls shall consist of a reinforced concrete footing and a reinforced concrete wall designed to resist soil pressures as specified in the geotechnical report.

- 4.1.2.2. Free-draining soil shall be provided on the back surface of retaining walls and water shall be removed from behind the wall by weep holes and a subdrain system.
- 4.1.2.3. Vertical control joints are required at a maximum spacing of 25 feet. Fifty percent of the horizontal reinforcement shall extend through control joints.
- 4.1.2.4. Vertical expansion joints are required at a maximum spacing of 75 feet. Horizontal reinforcement shall not extend through expansion joints.
- 4.1.2.5. Reinforced concrete retaining walls shall be designed by a registered engineer.

**4.1.3. Reinforced Masonry Retaining Walls**

- 4.1.3.1. Reinforced masonry retaining walls shall consist of a reinforced concrete footing and a reinforced masonry wall designed to resist soil pressures as specified in the geotechnical report.
- 4.1.3.2. Free-draining soil shall be provided on the back surface of retaining walls, and water shall be removed from behind the wall by weep holes and a subdrain system.
- 4.1.3.3. Vertical control joints are required at a maximum spacing of 24 feet. Fifty percent of the horizontal reinforcement shall extend through control joints.
- 4.1.3.4. Vertical expansion joints are required at a maximum spacing of 72 feet. Horizontal reinforcement shall not extend through expansion joints.
- 4.1.3.5. Reinforced masonry retaining walls shall be designed by a registered engineer.

**4.1.4. *Other types of retaining wall systems are not permitted without prior written approval from the BIA.***

**5030-5. Areas Adjacent to Buildings**

- 5.1. Areas adjacent to buildings that are to be unpaved should be sloped to direct surface water and roof drainage, including snow melt, away from buildings at a minimum of 12 inches in the first 10 feet of horizontal distance. Water should not drain across sidewalks unless approved by the BIA.
- 5.2. Areas to be paved with concrete should have a minimum slope of 0.5 percent and a preferred slope of 1.0 percent.
- 5.3. Areas to receive bituminous pavement should have a minimum slope of 2.0 percent to assure draining without ponding or “birdbaths.”



**5030-6. Unoccupied Site Areas**

- 6.1. Areas of the site that are to remain unoccupied should have adequate continuous slopes to drain toward watercourses, drainage swales, roadways, and the minimum necessary storm drainage inlets.
- 6.2. Drainage swales or channels should be sized and sloped to accommodate design runoff.
  - 6.2.1. Runoff should be carried under walkways in pipes with diameters of not less than 8 inches or of larger sizes if clogging by debris or grass cuttings is anticipated.
  - 6.2.2. Use swales to intercept water at the top and bottom of banks where large areas are drained. To provide positive drainage, a slope of not less than 2 percent for turfed areas is usually desirable, but more permeable soils may have adequate drainage with a lesser slope.
  - 6.2.3. Turf banks, where required, should be graded to permit the use of gang mowers, providing a maximum slope of 1 vertical in 3 horizontal, but if feasible, a preferred slope of 1 in 4.
- 6.3. The tops and bottoms of all slopes should be gently rounded in a transition curve for optimum appearance and ease of maintenance.

**5030-7. Subgrading Procedure**

- 7.1. The site area subgrade should be established parallel to the proposed finished grade and at elevations to allow for the thickness of topsoil or other surface.
- 7.2. In fill areas, all topsoil, debris, and other noncompatible materials should be removed; all tree stumps shall be removed or cut out 24 inches below grade.
- 7.3. On sloping areas to be filled, where the original ground is clay, the original ground should be scarified to a depth of 12 inches to provide bond for fill material.
- 7.4. Fill material should be free from debris and have a moisture content and compaction density sufficient to prevent settlement damage to drainage structures, walks, or other planned improvements.

**5040-1. General**

- 1.1. This chapter presents guidelines for preparing an erosion and sedimentation control (ESC) plan. An ESC plan is a drawing that should be prepared and issued with the project civil construction documents. The ESC plan should show the proposed grading and storm water drainage system along with the appropriate best management practices (BMPs) necessary to prevent sediment from leaving the project site, due either to storm water or winds.
- 1.2. In addition to the ESC plan, a storm water management plan (SWMP) must be prepared for each project. This report, which must be prepared by the Designer of Record or the contractor, describes appropriate controls and measures (BMPs) to improve water quality by reducing pollutants in storm water discharges. In 1972, Congress passed the Clean Water Act, a comprehensive set of programs that includes the National Pollutant Discharge Elimination System (NPDES). The NPDES regulates the discharge of pollutants into the waters of the United States. Most states implement the NPDES program and locally provide guidance and permitting for compliance with the program. A General Permit for Storm Water Discharges associated with construction activities must be obtained either through the state of the proposed construction project or directly through the U.S. Environmental Protection Agency (EPA). A SWMP is required as part the General Permit for Storm Water Discharges associated with construction activities. The Designer of Record must obtain and follow local guidance, if available, when preparing the SWMP, or use the latest version of the EPA's *Storm Water Management for Construction Activities*, EPA 833-R-92-001.

**5040-2. Erosion and Sedimentation Control Plan**

- 2.1. The ESC plan should represent the Designer of Record's best estimate of the BMPs that will be required during construction. The SWMP should emphasize the contractor's obligation to regularly inspect and maintain specified BMPs, as well as to routinely implement new BMPs as warranted by various phases of the construction project.
- 2.2. Temporary and permanent erosion control and storm water control measures (BMPs) implemented on the site should be shown on the drawing.
- 2.3. Pre-development and post-development storm water runoff conditions should be considered when preparing the plan.
- 2.4. Type and frequency of maintenance activities should be noted on the plan.
- 2.5. Potential pollution sources anticipated from the site should be identified and addressed by BMPs shown on the plan.

### 5040-3. Best Management Practices

- 3.1. At a minimum, general practices for preventing storm water pollution are as follows:
  - 3.1.1. Prior to construction, the limits of construction disturbance should be identified. Restoration of previously developed sites should also be noted at this time.
  - 3.1.2. Before clearing and grubbing, sediment barriers shall be installed to intercept sheet flows that might potentially deposit sediment onto public rights-of-way; this includes a barrier at the construction entrance/exit, such as a temporary gravel construction pad.
  - 3.1.3. Wind erosion control methods, such as silt fence, mulching, and soil roughening, should be added if necessary during overlot grading.
  - 3.1.4. Following utility installation, a temporary or perennial grass seed mixture should be applied; if additional anchoring is required, use straw/hay mulch.
  - 3.1.5. In areas to be paved, an early application of gravel shall be completed.
  - 3.1.6. All control measures shall be inspected and repaired as necessary—biweekly in dry periods, and within 24 hours after a rainfall event of 0.5 inches within a 24-hour time period.
    - 3.1.6.1. During prolonged rainfall, daily inspections should take place, and repairs should be implemented as necessary.
  - 3.1.7. Temporary erosion control shall be exercised by minimizing exposed areas and slopes until permanent measures are effective.
  - 3.1.8. If a fueling area is to be designated on-site, it must not pollute storm water; fueling areas shall be a minimum of 100 feet from drainage channels and/or storm sewer systems and be enclosed by a minimum 12-inch-high compacted berm capable of retaining potential spills.
  - 3.1.9. Sediment control measures shall be removed upon final stabilization of lands that contribute runoff waters to the structures.
- 3.2. **Surface Stabilization Techniques**
  - 3.2.1. After construction begins, the soil surface needs to be stabilized to the extent feasible within a 7-day period in areas where disturbance occurred and that may remain unfinished for more than 14 calendar days.
  - 3.2.2. Raindrop impact, flowing water, and wind are forces that cause erosion. Measures that can be taken to reduce this effect are listed in Figure 5040-1.

**Figure 5040-1: Time Limits of Land Exposure for Erosion Control Selection**

| <b>Erosion Control Method</b>  | <b>Maximum Allowable Period of Exposure (Months)</b> |
|--------------------------------|--|
| Surface roughening             | 1  |
| Mulching                       | 12   |
| Temporary revegetation         | 12–24  |
| Permanent revegetation         | 24 or more   |
| Soil stockpile revegetation    | 2  |
| Early application of road base | 1  |

- 3.2.3.** Surface roughening, also known as scarification, is done using a chisel or ripping implement to create depressions 2 to 4 inches deep, spaced approximately 4 to 6 inches apart. This method is used to provide temporary stabilization from wind and water erosion where revegetation is not an option due to seasonal conditions.
- 3.2.4.** Mulching is the application of plant residues or other suitable materials to the soil surface, usually clean, weed- and seed-free, long-stemmed grass hay or cereal grain straw, which is anchored; another option is hydraulic mulching, which is applied to steeper slopes, sometimes mixed with wood cellulose and a tackifying agent.
- 3.2.4.1.** Anchoring into the soil should be no more than 2 inches, and the mulch should not be covered with excessive amounts of soil.
- 3.2.4.2.** Cut or fill slopes greater than 6 feet high or steeper than a 3 in 1 slope require the use of erosion control blankets.
- 3.2.5.** Revegetation should be established within one year on all disturbed areas and on soil stockpiles not permanently stabilized by other means. Revegetation is not considered established until it can control soil erosion and survive severe weather conditions.
- 3.2.5.1.** Botanical species to be planted should be compatible with the region to be seeded; seeding rates should also be determined according to the native vegetation in the area.
- 3.2.5.2.** Seedbed preparation is sometimes necessary in areas where exposed soil lacks the necessary nutrients to support vegetation.
- 3.2.5.3.** Soil should be loosened by disking or other means to prepare the site for seeding.
- 3.2.5.4.** Seeds should be planted about 1/4-inch deep, with a maximum depth of 1/2 inch. Distances between furrows should be less than 8 inches.

- 3.2.5.5.** Vegetative stabilization is considered complete when at least 70 percent of the historic cover exists.
- 3.2.6.** Temporary revegetative seeding should be protected with mulch, and the seed should be an annual grass native to the area. This method is required on all disturbed areas that will have been exposed for at least 12 months.
- 3.2.7.** Permanent revegetation requires a perennial grass or grass mix for areas that have been disturbed but where construction will not begin for two or more years; these areas shall be protected by mulch as well.

**5050-1. General**

- 1.1. This section provides general information on the design and planning of the utility infrastructure for BIA Justice / Detention facilities. Refer to individual utility sections for specific criteria.
- 1.2. All utilities should be kept to minimum interference with one another; provide horizontal and vertical separations, as well as maintenance access that does not violate easement boundaries.
- 1.3. No planting, including trees, or placement of structures shall be allowed within 10 feet of either side of any utility line.
- 1.4. Marker posts shall be provided for any utility structures, including valve boxes, manholes, inflection points, or dead end.
- 1.5. Submitted plans should include profiles showing intersection spacing of all utility infrastructures.

**5050-2. Water, Sanitary (Wastewater), and Storm Drainage Systems**

- 2.1. Refer to individual relevant sections of this chapter for specific criteria.

**5050-3. Fuel Lines**

- 3.1. Show the location of gas mains, service lines, liquefied petroleum gas (LPG) tanks, fuel tanks, and other facilities serving and on the property and indicate their capacities.
- 3.2. Refer to Chapter 10, "Mechanical," for fuel line criteria.

**5050-4. Electrical, Telephone, and Television Cable**

- 4.1. Indicate the location of all such services available to the property, and the size of the main serving each.
- 4.2. Refer to Chapter 11, "Electrical," for full criteria.

**5050-5. Minimum Data**

- 5.1. Provide information about operating authority, contact persons, size and capacities, and locations of utilities.

**5050-6. Distant Utilities**

- 6.1. Identify utilities not available to the site, and indicate if the service is available nearby.

**5050-7. Surface Water**

- 7.1. Indicate bodies of water located near the site and record their elevations. Also note stream and flood levels, as well as recent flood occurrences.
- 7.2. Identify effective 100-year and 500-year flood lines.
- 7.3. Indicate the extent of watershed tributary to the property.

**5060-1. General**

1.1. This section provides guidelines for water systems to be used in BIA Justice / Detention facilities, including supply sources, pumping, treatment, storage, and distribution for domestic, industrial, irrigation, and fire protection purposes.

**1.2. Applicable Publications**

1.2.1. For water system design, distribution, storage, treatment, disinfection, and pumping requirements, refer to:

- American Water Works Association (AWWA) standards
- Ten-State Standards for Water Works
- U.S. Environmental Protection Agency (EPA) regulations and recommended technologies
- The minimum BIA design standards for water use noted in this section

1.3. Wherever available, Justice / Detention facilities should be connected to municipal water sources (tribal or state-approved city or community water supply) for reliability, quality, and quantity. Other supply sources should be designed by a geohydrologist and/or a professional engineer after completion of field investigations and preparation of a comprehensive report of the source. Water sources include the following:

- Surface (creeks, rivers, and lakes)
- Subsurface (wells)
- Springs

1.4. Consider additional water supply demands associated with tribal housing, future development, and other possible usages.

**1.5. Water Consumption**

1.5.1. *Average Day Use:* If water consumption data is available from an existing facility of similar use and size, those values may be used. At a minimum, the values indicated in Figure 5060-1 shall be used for average day demand.

**Figure 5060-1: Average Day Water Consumption\***

| Type of Facility                                      | Units            | Flow<br>(Gallons/Units/Day) | Flow<br>(Gallons/Capita/Day) |
|---|------------------|-----------------------------|------------------------------|
|   |                  | Minimum Water Available     | Adequate Water Available     |
| Jail  | Inmates          | 80                          | 120                          |
| Courthouse /<br>Law<br>Enforcement/<br>Administration | Employee / shift | 10                          | 16                           |

\*If potable water is to be used for irrigation, additional flow demand must be considered.

**1.5.2. Peaking Factors:** Adequate flow capacity and pressure is to be provided based on peak hour demand or peak day plus fire flow demand, whichever is greater. Use the peaking factors (PFs) shown in Figure 5060-2 to calculate minimum flow demands under the specified conditions.

**Figure 5060-2: Peaking Factors – Minimum (Average Day x PF)**

| Average Day | Peak Day | Peak Hour |
|-------------|----------|-----------|
| 1.0         | 3.0      | 5.0       |

**5060-2. Water Source Criteria (Non-Municipal)**

- 2.1. Water sources must be examined for expected safe yields; the watershed or source location, noting existing or potential sources of contamination; relevant geologic conditions; expected water quality; required water storage capacities and elevations; and pumping system requirements. Water quality is to be analyzed and treatment needs identified for each water source.
- 2.2. When municipal water is not available, wells are the preferred water supply source; they may be deep aquifer (greater than 100 feet), or alluvial (less than 100 feet). Alluvial wells must be free of microscopic particulates.
  - 2.2.1. All waters post-treatment must comply with all Federal Safe Drinking Water Act requirements.
  - 2.2.2. Wells shall not be constructed within the 100-year floodplain.
  - 2.2.3. Wells shall be constructed with a sanitary seal.
  - 2.2.4. Wells must be vented and covered with a 24-mesh corrosion-resistant screen.
  - 2.2.5. Wells shall have a 4-foot diameter concrete pad poured around the well casing.



- 2.2.6. If accommodations must be made in colder environments, wells shall have a pitless adapter. This allows for flow into the building despite the depth of frozen soil.
- 2.2.7. Well vaults are not permitted.
- 2.2.8. Well pumps and depth settings shall be specified by a groundwater hydrogeologist. Well borings shall be sampled. Sediment samples from anticipated production zones are to be analyzed for parameters to assist with well design. Well design shall identify casing size and lengths, grouted intervals, well screen slot size(s), screen length, filter pack requirements, centralizers, and testing requirements for well construction.

### 5060-3. Well-Pumping Units

- 3.1. Design well-pumping equipment to meet the required well capacity based on test pump data or on the specific requirements of the project, whichever is less.
- 3.2. Provide lightning arrestors as part of well controls. Pump controls should be electrode actuators in the water storage tank, where feasible; otherwise, use manual or pressure controls.
- 3.3. Install electrode shutoffs in all wells to prevent over-pumping of the well and damage to the pumping unit. Refer to Chapter 11 for electrical standards.
- 3.4. Well pump houses should be sized adequately for easy equipment operation and maintenance. Use space heaters or other approved methods to prevent pump house piping from freezing.
- 3.5. Pressure gauges, check valves, gate valves, meters, valved test pipes, and other appurtenances necessary on the well discharge line should be provided.
- 3.6. Motors should drive the pumps under the service required without exceeding 85 percent of the specified rating, in accordance with the National Electrical Manufacturer's Association Motors and Generators (NEMA MG1) standard. Refer to Hydraulic Institute standards for motor type discussions.

### 3.7. Flow Meters

- 3.7.1. Pumped water is metered for the following reasons: to calculate distribution system losses, the difference between meter reading total and supply total; to monitor pump efficiency; and to determine gross billings for water supplied. Provide 10 pipe diameters upstream and 5 pipe diameters downstream in straight piping to assess meter accuracy.
- 3.7.2. The flow meters most common in water pumping installations are, in order of preference, magnetic meters, propeller meters, turbine meters, and differential pressure meters.
  - 3.7.2.1. Magnetic meters are preferred based on accuracy and range of flow, including typical ranges of 10 to 1 and plus or minus 0.5 to 1.0 percent accuracy.

- 3.7.2.2. Propeller meters, with an accuracy of plus or minus 2 percent over a 10 to 1 range, are next in order of preference. Such meters should meet AWWA C704 standards. Propeller meters have a lower initial cost because of their small size and simple design, and have historically proven effective.
- 3.7.2.3. Turbine meters are typically used for systems with a small range of flow. These meters must meet the standards of AWWA C701.
- 3.7.2.4. Other meters can be considered based on specific site conditions. Differential pressure meters may be considered in circumstances that can be justified in writing by the Designer of Record; however, differential pressure meters are not as accurate as magnetic meters.

### 3.8. Springs

- 3.8.1. Springs shall not be developed within the 100-year floodplain.
- 3.8.2. Springs, if not fed by surface water, will normally need only disinfection for treatment prior to use, whereas surface waters require complete treatment prior to use.
- 3.8.3. Evaluate the reliability of future flow capacities of springs prior to excluding other water source options.

### 3.9. Surface Water

- 3.9.1. All surface water used for potable water shall receive complete treatment before use.
- 3.9.2. The watersheds of surface water sources shall be protected from uses that could cause them harm.
- 3.9.3. Surface water intakes, direct diversion infiltration galleries, or subsurface diversion shall be designed to prevent possible vandalism.
- 3.9.4. Surface water sources intake structures shall be designed to shut down due to upstream conditions such as high turbidity, hazardous spills, etc.

## 5060-4. Water Distribution

- 4.1. The water distribution system comprises the network of piping throughout building areas and other areas of water use or fire demand, including hydrants, valves, and other appurtenances used to supply water for domestic and fire fighting purposes.
- 4.2. Pipe Layout
  - 4.2.1. The sanitary sewer pipe should be below the water main lines with an 18-inch difference between the invert of the water main and the crown of the sewer pipe. Under unusual conditions, should the sewer pass over the water main, the spacing shall remain 18 inches; if vertical separation is less than 18 inches, provide structural support for the sewer pipe.

- 4.2.2. The sanitary sewer shall be one continuous length of watertight pipe 20 feet long centered on a water main. Joints are to be encased in concrete a minimum of 6 inches thick and should extend 6 inches on either side of the joint. As an alternative, sewer pipe may be fully encased in 6 inches of concrete around the pipe and extend 10 feet horizontally on either side of the water main.
- 4.2.3. Thrust restraint calculations must be performed. The Designer of Record shall include thrust blocks for all bends and dead ends, as well as pipe joint restraint.
- 4.2.4. The preferred location of water mains is parallel to roadway right-of-way or curb line 10 feet outside of pavement edges. Prior to locating water mains within the roadway, a benefit versus long-term maintenance cost analysis must be submitted to and approved by the BIA. See further discussion in Paragraph 4.3.
- 4.2.5. The BIA will consider topography in relation to layout and long-term maintenance when water mains are connected to existing systems.
- 4.3. The alignment, depth, flow direction, and size of all waterlines, sanitary sewer, storm drain, and steam lines should be located and plotted. Also indicate location, elevation, and depth of manholes, catch basins, and water valves (horizontal and vertical).
- 4.4. If the BIA approves the location of water mains within the roadway, water mains should be a minimum of 4 feet from the outside of the pipe to the lip of the curb in the middle of the roadway section. If possible, water shall be 10 feet north or east of the centerline.
  - 4.4.1. Elevations should be indicated to the nearest 0.01 foot.
- 4.5. **Tracer Wire.** Tracer wires for water mains shall be installed with all plastic pipes.
  - 4.5.1. The wire shall be plastic-covered #12 AWG (4-square-millimeter) type THWN taped to the top of the waterline with 10-millimeter tape. Plastic cover for waterline tracer wire shall be blue, and for reclaimed wastewater (graywater), it shall be purple.
  - 4.5.2. A 5-pound magnesium anode shall be installed for each 1,000 linear feet of tracer wire, or at each end of the project, near the curb next to a water service. It shall be placed in a separate cast-iron box a minimum of 1 foot from the water service.
  - 4.5.3. The tracer wire connection station shall be installed at each fire hydrant and street intersection, for each 500 linear feet, and at each end of the project.
  - 4.5.4. Tracer wire shall be tested prior to paving and owner acceptance to show that all water/reclaimed wastewater mains can be located in this manner; the owner's representative shall witness the tests.

- 4.5.5. All information necessary for the wire, anode, and connection station locations shall be provided to the owner.
  - 4.5.6. All tracer wire splices shall be Bundy KS17, 12 AWG copper split connectors.
  - 4.5.7. The construction plans should show all tracer wire, anodes, and connection stations.
  - 4.5.8. Six-inch-wide, 4-mil-thick plastic warning tape shall be placed 12 to 24 inches below finished grade above mains; blue for water mains, purple for reclaimed wastewater mains, and green for sewer mains. The tape shall be printed at least every 36 inches with “BURIED WATERLINE BELOW,” “BURIED RECLAIMED WASTEWATER LINE BELOW,” and “BURIED SEWER BELOW” for each respective pipe.
- 4.6. Pipe.** Main waterline pipe diameter shall be a minimum of 8 inches. Design a looped water system where practical to maintain water quality and provide appropriate fire suppression. Polyvinyl chloride (PVC) piping is the preferred material unless the Designer of Record can write a supporting document of explanation for use of an alternate material. Possible supporting conditions may include thermal or other pertinent soil conditions.
- 4.6.1. PVC pipe must conform to the AWWA C900 standard and is used in situations requiring a 4-inch minimum diameter.
  - 4.6.2. Ductile iron pipe (DIP) must conform to AWWA C151 standards, Class 52, and is used for 3-inch and larger diameters.
  - 4.6.3. Service lines shall be copper piping and must conform to ASTM B88 and AWWA C800. Copper pipe should be used for 2-inch or smaller diameter pipe, and should be Type K, water tube, seamless, annealed temper, with flared connections. Water service lines should extend to all new buildings from existing and/or new water distribution mains. The pressure loss through the service line should not exceed 10 pounds per square inch (psi) at the peak building demand, including head losses through the water meter.
  - 4.6.4. Fire hydrant laterals shall be DIP fully restrained between the fire hydrant and main.
  - 4.6.5. The minimum waterline cover shall be 3 feet, or to a depth equivalent to the maximum frost penetration plus 12 inches, whichever is greater. Maximum water main depth should not exceed 4 feet deeper than minimum required depths.
  - 4.6.6. All water distribution systems should be designed according to the pressures noted in Figure 5060-3.

Figure 5060-3: Operating Pressures

| Operating System Pressure | Under All Flow Conditions (Including Fire Flows) | At Highest Building Floor Level |
|---------------------------|--|---------------------------------|
| Maximum                   | 80 psi   | –                               |
| Normal                    | 60 psi   | –                               |
| Minimum                   | 20 psi – during a fire                           | 40 psi                          |

#### 4.7. Valves

- 4.7.1. Distribution system valve types include: gate valves (12 inches and smaller), butterfly valves (14 inches and larger), and ball valves for isolation. Specialty valves may also include pressure-reducing valves, check valves, blow-off valves, and relief valves.
- 4.7.2. The system should have valves that allow the sections to be isolated without total system shutdown. Isolation valves for fire lines shall include a post indicator.
- 4.7.3. Locate isolation valves no more than 500 feet apart in areas with BIA occupied facilities, and no more than one block or 800 feet apart in other facility installations. Valves 3 inches to 12 inches shall be resilient-seated nonrising stem gate valves conforming to AWWA C509. Valves larger than 12 inches shall be rubber-seated leaktight butterfly valves conforming to AWWA C504.

#### 5060-5. Water Storage

##### 5.1. Types (for Justice / Detention facilities Not Connected to Municipal Systems)

- 5.1.1. **Concrete on Grade.** Concrete foundations, concrete walls, and concrete lids shall be designed and detailed in accordance with American Concrete Institute (ACI) 350 *Code Requirements for Environmental Engineering Concrete Structures* and ASCE 7 *Minimum Design Loads for Buildings and Other Structures*.
- 5.1.1.1. Concrete shall have a minimum compressive strength of 4,000 pounds per square inch, a maximum water-cement ratio of 0.45, and a maximum chloride ion limit of 0.10 percent of the weight of the cement.
- 5.1.1.2. Concrete tanks shall be tested in accordance with ACI 350.1 *Tightness Testing of Environmental Engineering Concrete Structures*.
- 5.1.1.3. The inside surface of concrete tanks shall have a smooth formed finish, as defined by ACI 301 *Specifications for Structural Concrete*.
- 5.1.2. **Concrete Below Grade.** Same as for concrete on grade (see above).

**5.1.3. *Steel on Grade.*** Foundations for steel tanks on grade shall be designed in accordance with the guidelines in Chapter 9, “Structural,” for the anticipated design loads, as provided by the tank manufacturer. Where a concrete slab serves as the bottom of the tank, the slab shall conform to requirements for concrete tanks.

**5.1.4. *Steel Elevated (Four-Legged/Pedestal).*** Foundations for elevated steel tanks shall be designed in accordance with the guidelines in Chapter 9, “Structural,” for the anticipated design loads as provided by the elevated tank manufacturer.

## **5.2. Sizing and Design Requirements**

**5.2.1.** Tanks shall have a minimum capacity of 60,000 gallons for fire fighting at 500 gallons per minute for a 2-hour duration, plus three days average water usage.

**5.2.2.** For ease of maintenance, multiple tanks are preferred. For smaller systems, a single tank is acceptable.

**5.2.3.** Provide additional fire water storage for fire flows that exceed 500 gallons per minute based on a 2-hour duration.

**5.2.4.** Tanks shall be located above the 500-year floodplain.

**5.2.5.** All tank structures shall have visible overflow discharge piping.

**5.2.6.** All tank structures shall be vented, with vents having a 24-mesh copper screen.

**5.2.7.** Finished water tanks shall be disinfected in accordance with AWWA C652 and tested to demonstrate bacterial safety prior to use.

**5.2.8.** Cathodic protection devices must be provided on all steel-structured water tanks. Provide cathodic protection calculations indicating the requirements necessary.

## **5.3. Small Capacity Water Storage**

**5.3.1. *Hydropneumatic Pressure Systems.*** In Justice / Detention facilities with small populations where demand does not justify major storage, hydropneumatic systems may be used.

**5.3.2.** The system must operate at a range of 50 to 70 psi.

**5060-6. Water Treatment**

- 6.1. All water from non-municipal sources shall receive treatment prior to use. The type of treatment required is determined by the complete chemical and bacteriological raw water analysis. The suggested treatment capacity is the peak day demand for the system.
- 6.2. All required treatment must comply with state and federal Clean Water Act criteria and regulations.
- 6.3. Water from groundwater sources (nonalluvial) normally requires only disinfection treatment prior to potable use.
- 6.4. Alluvial wells require a microscopic particulate analysis prior to determining the type of treatment required. Well water with no particulate count will normally require only disinfection. Well water with particulates will also require filtration (pressure).

**6.5. Filtration****6.5.1.** Filtration types to be considered are:

- Cartridge/bag filtration. This system minimizes maintenance and is preferred.
- Rapid sand, gravity, or pressure.
- Slow sand filtration.

**6.5.2.** All filtration systems shall have two units, and final design of water treatment facilities shall consider the following criteria for filtration:

- Hydraulic loading rates
- Filter media
- Surface and subsurface wash
- Backwash
- Sampling taps
- Continuous turbidity recording devices

**6.6. Disinfection**

- 6.6.1. All non-municipal water furnished to the public shall be disinfected unless a proven well has a waiver of disinfection from the state regulatory authority based solely upon historical records.
- 6.6.2. Where surface waters are used, raw water, applied water, and finished water should be disinfected with chlorine.
- 6.6.3. Chlorination may be accomplished with:
  - Sodium hypochlorite solution feed. This is the preferred method unless a written report identifies specific reasons why the system is

not applicable. The report must be provided by the BIA. Characteristics such as flow volume will be considered.

- Gas chlorine.
- 6.6.4. Gas chlorine should not be used in systems using less than 0.10 million gallons per day (mgd).
  - 6.6.5. Special design criteria apply when disinfecting with chlorine gas. For the criteria to be followed, contact the state environmental office that has jurisdiction. All safety provisions shall be applied, including but not limited to storage chlorination rooms (leaktight, exhaust, wash stations, gas masks, etc.).
  - 6.6.6. After chlorination, detention time shall be at least 30 minutes prior to reaching the first tap.
  - 6.6.7. The design shall include a standby chlorination unit.
  - 6.6.8. Tablet type chlorine feeders are not acceptable.
  - 6.6.9. The minimum residual chlorine concentration reaching the distribution system shall not be less than 0.2 of a milligram per liter.
  - 6.6.10. Ultraviolet light disinfection is not acceptable.

#### 5060-7. Pumps

- 7.1. Type of station, intake, design capacities, and operating heads (maximum, minimum, submergence—to produce a net positive suction head) are the main factors in selecting pump types. There are two main types of pumps used for domestic water: vertical turbine pumps and centrifugal pumps.
- 7.2. Pump station design shall meet the requirements of the Hydraulic Institute and standard requirements of the NFPA.
- 7.3. **Criteria for Pump Type Selection**

##### 7.3.1. *Pump Capacity*

- 7.3.1.1. Attempt to meet peak demands with two or three duty pumps. Accommodate normal flow demand with one pump. An effort should be made to limit the number of pump sizes. Consider low-flow issues related to the need for a jockey pump or recirculation pump.

##### 7.3.2. *Pump Operating Conditions*

- 7.3.2.1. Consider either constant speed or variable speed pumps to provide for anticipated demands. Long-term maintenance of the system is paramount to this decision; therefore, constant speed pumps are the preferred system.
- 7.3.2.2. Because it will eliminate many operational problems, a net positive suction head (NPSH) is required for all pumps.



- 7.3.2.3. To mitigate cavitation issues, select a pump with a pump curve that is as steep as possible.
- 7.3.2.4. Select a pump with as low a horsepower as possible that still maintains a non-overloading motor.
- 7.3.2.5. To conserve energy and extend the life of the system, select a pump with as low an rpm as possible.
- 7.3.2.6. Verify proper pump selection by comparing the pump curve(s) to the system head curve(s).
- 7.3.2.7. Other pump selection considerations should include client preference, locality, budget, maintenance, and schedule (pump delivery).
- 7.3.2.8. Determine the extent of automation, control, and telemetry needed for the pump system.
- 7.3.2.9. All pump systems must have a standby power source unless the Designer of Record provides documentation with compelling reasons why backup power is not possible. The BIA must approve any non-use of backup power.

### 7.3.3. *Pump Station Site Selection*

- 7.3.3.1. A pump site must not be subject to flooding conditions or be located within a 500-year floodplain.
- 7.3.3.2. Identify the locations of the water supply and the pump station. Consider topography in relation to layout and long-term maintenance. Above-ground pump stations are preferred. If an above-ground location is not possible, design for a nonconfined-space, below-grade configuration.
- 7.3.3.3. Site selection must consider noise abatement for all aspects of the water system. Decibel levels exceeding existing conditions without the written consent of the BIA will not be allowed.

## 7.4. Pump Applications

- 7.4.1. *Booster Pumps.* These increase the pressure in the pipeline to desired levels, where necessary, and may be located above ground or below ground. Due to varied topography, they are usually located remotely from the main pump station.
- 7.4.2. *High Lift Pumps.* These pump directly into transmission lines and distribution systems.

## 7.5. Pump Station Piping

- 7.5.1. Piping within a pump station may consist of properly restrained ductile iron, PVC (nonsolvent welded), and steel pipe meeting ASTM A312 for 3/4-inch through 30-inch.

- 7.5.2. Fittings for 2-inch and smaller pipe should be threaded and should conform to ASTM A403 and ANSI B16.3. Larger fittings should be butt welded, grooved end, or flanged and should conform to ASTM A403 or A774 and ANSI B16.9.
- 7.5.3. Thrust restraint, including pipe supports, hangers, concrete base elbow support, steel pipe support, or similar thrust restraint, must be properly sized, spaced, and located to resist pipe movement.
- 7.5.4. Valving should be flanged and have operating mechanisms to allow for easy indoor opening and closing (hand wheel, chain wheel).

#### 5060-8. Fire Protection

- 8.1. Distribution lines and fire hydrants should be addressed upon completion of the hydraulic analysis, and should meet the requirements of the BIA installations.

#### 8.2. Applicable Criteria

- NFPA 20 Standard for the Installation of Stationary Fire Pumps for Fire Protection
- NFPA 24 Installation of Private Fire Service Mains and Their Appurtenances
- NFPA 5000: 55 Standpipe and Hose Systems
- Applicable state criteria

- 8.2.1. Comply with NFPA 13 Ordinary Hazard classification occupancy requirements when the installation is located outside a municipal/city service area, and specify bypass valves and flow metering devices to prevent the restriction of fire flows. All sprinkler service lines 3 inches and larger should be equipped with post indicators on the service line shutoff valves.

- 8.2.2. Meet state fire marshal or Insurance Services Office requirements when the facility is located in a municipal/city service area and such requirements exceed BIA requirements.

#### 8.3. Fire Hydrants

- 8.3.1. Hydrants shall have 5.25-inch diameter barrels, minimum, with two 2.5-inch hose connections and one 4.5-inch pumper connection.
- 8.3.2. Hydrants shall be designed for 150 psi working pressure or 300 psi hydrostatic pressure, and not less than 20 psi residual pressure.
- 8.3.3. Working parts shall be bronze and hose threads shall conform to the National Pipe Thread (NPT) standards. Exceptions are only in municipalities/cities where hydrants are designed for their own firefighting equipment.

- 8.3.4.** Dry barrel, traffic breakable model fire hydrants shall be used, and shall conform to AWWA C502 requirements.
- 8.3.5.** Maximum spacing between fire hydrants shall be 400 feet; however, this spacing applies to systems with large line sizes and high pressures. Normally, hydrants will be spaced at 325 to 350 feet. The minimum distance between any fire hydrant and a building shall be 50 feet. The maximum distance to a fire hydrant from any point on the building perimeter shall not exceed 250 feet.
- 8.3.6.** All hydrant leads shall be a minimum of 6 inches in diameter. A 6-inch gate valve box shall be installed on each hydrant lead upstream of each fire hydrant.
- 8.3.7.** Color code fire hydrants by flow capacities as shown in Figure 5060-4:

**Figure 5060-4: Fire Hydrant Color Coding**

| <b>Hydrant Flow (Gallons/Minute)</b> | <b>Color</b>  |
|--------------------------------------|---------------|
| 750 or greater                       | Chrome yellow |
| 50 to 750                            | Green         |
| Less than 50                         | Red           |

**5070-1. General**

- 1.1. This section shall be used as a guideline for the design and construction of all wastewater systems in BIA Justice / Detention facilities, whether they are connected to a central (municipal) collected system or not. The preferred sanitary sewer system is one connected to a central/municipal system. If a municipal system is not available within a reasonable distance, alternative treatments are to be evaluated.
- 1.2. Wastewater systems include collection, pumping, treatment, and disposal of domestic and industrial wastes.
- 1.3. Designs and construction of wastewater systems may vary based upon local criteria and/or submittal processes.
- 1.4. **Applicable Publications**
  - 1.4.1. All design and construction shall meet EPA regulations and more stringent state water quality discharge standards.
  - 1.4.2. All design and construction shall conform to the American Society of Civil Engineers (ASCE) Manuals and Reports on Engineering Practice No. 37, Design and Construction of Sanitary and Storm Sewers.

**5070-2. Wastewater Flow and Waste Loads****2.1. Determination of Loads**

- 2.1.1. Flows to wastewater treatment facilities shall be calculated as 90 percent of domestic potable water usage flows meeting the criteria listed in Section 5060, Figure 5060-1.
- 2.1.2. For purposes of the design of the treatment facility, peak daily flows shall be four times the average daily flow.
- 2.1.3. Sewer systems, trunk lines, and outfall lines should be designed to service the ultimate density of the tributary area.

**5070-3. Treatment System Selection and Analysis****3.1. Selection**

- 3.1.1. Wastewater treatment shall conform to applicable state criteria. Designs shall be based on meeting the requirements of a National Pollutant Discharge Elimination System (NPDES) discharge permit, as provided by the state or the EPA.
- 3.1.2. Where two or more alternatives are available and feasible for providing public wastewater facilities, base all new designs on the most economical plan consistent with the applicable criteria. The BIA prefers that all treatment systems be lagoons, unless specifically stated or approved otherwise.

**3.2. Aerated and Facultative Lagoons**

- 3.2.1. Wastewater lagoons shall be as far as practicable from the nearest residence or building, a minimum of 1,000 feet, with a preferable minimum distance of 1,500 feet.
- 3.2.2. Nonaerated lagoon systems shall have a minimum of two cells and shall be designed to operate in both series and in parallel formation.
- 3.2.3. Valving shall be provided so that flow can be discharged directly to or from either cell.
- 3.2.4. Cells should be shaped to minimize short-circuiting. Rectangular ponds with a length not exceeding three times the width are recommended. Site geometry should be considered in configuration design.
- 3.2.5. Interior sides shall be sloped no greater than 3 to 1 and all interior corners shall be rounded.
- 3.2.6. Nonaerated lagoons shall have a minimum freeboard above the high-water line of 3 feet; aerated lagoons shall have a minimum freeboard of 2 feet.
- 3.2.7. Lagoon embankments shall be constructed of impervious material and compacted to greater than 95 percent Proctor.
- 3.2.8. Lagoons shall be constructed so allowable seepage out of the bottom will not exceed 1/32 of an inch per day ( $10^{-6}$  cm/s).
- 3.2.9. Where seepage from lagoons will exceed 1/32 of an inch per day, lagoons shall be lined with bentonite, native clay material, asphalt, or synthetic liners. Failure to seal lagoons will require obtaining a water discharge permit.

Figure 5070-1: Facultative Lagoon Criteria, Disposal Method

|   | Continuous Discharge | Controlled Discharge | Land Application      | Total Retention              |
|---|----------------------|----------------------|-----------------------|------------------------------|
| <b>Primary Cells</b>                            |                      |                      |                       |                              |
| Minimum number <sup>1</sup>                     | 2                    | 2                    | 1                     | 1                            |
| BOD <sub>5</sub> loading (pounds/acre/day)      | 15–35                | 15–35                | 15–35                 | 15–35                        |
| Normal operating range (feet)                   | 4–5                  | 4–5                  | 4–5                   | 4–5                          |
| Max. depth w/o aeration (feet)                  | 6                    | 6                    | 6                     | 6                            |
| Detention time <sup>2</sup> (days)              | 40–80                | 40–80                | 40–80                 | 40–80                        |
| Max. seepage rate <sup>3</sup> (inches/year)    | 6                    | 6                    | 6                     | 6                            |
| <b>Secondary or Storage Cells</b>               |                      |                      |                       |                              |
| Minimum number                                  | 1                    | 1                    | 1                     | 1                            |
| Normal operating range (feet)                   | 4–5                  | 4–5                  | 4–5                   | 4–5                          |
| Max. depth w/o aeration (feet)                  | 6                    | 6                    | 6                     | 6                            |
| Minimum depth <sup>4</sup> (feet)               | 2                    | 2                    | 2                     | 2                            |
| Max. seepage rate <sup>3</sup> (inches/year)    | 15                   | 15                   | 15                    | 15                           |
| <b>Overall System</b>                           |                      |                      |                       |                              |
| Max. BOD <sub>5</sub> loading (pounds/acre/day) | 30                   | 30                   | 30                    | 30                           |
| Minimum detention time (days)                   | 180                  | 180                  | 90–120                | Total retention <sup>6</sup> |
| Emergency or winter storage (days)              | N/A                  | N/A                  | 60–150 <sup>5,6</sup> | Total retention <sup>6</sup> |

- Notes:**
1. All primary cells shall be approximately equal in size.
  2. All detention times are based on volume between the 2-foot level and the maximum design depth.
  3. Unless groundwater conditions dictate a lower seepage rate; for example, because of contamination of a drinking water supply.
  4. Minimum depth represents the lowest operating level for temporary operation or maintenance purposes only. This level is not to be considered or utilized as a normal operating depth.
  5. Shorter time periods for infiltration/percolation disposal and longer time periods for irrigation.
  6. A month-by-month water balance must be submitted with each land application or total retention disposal plan.

Figure 5070-2: Aerated Lagoon Criteria, Disposal Method

|  | Continuous Discharge | Controlled Discharge | Land Application | Total Retention  |
|--|----------------------|----------------------|------------------|------------------|
| Minimum number of aerated cells <sup>1</sup>   | 2                    | 2                    | 1-2 <sup>2</sup> | 1                |
| Recommended mode of aeration <sup>3</sup>  | Tapered              | Tapered              | Equal            | N/A              |
| Minimum design oxygen requirements (pounds O <sub>2</sub> /pound BOD <sub>5</sub> removed <sup>4</sup> )<br>depth (feet) | 2.0                  | 2.0                  | 2.0              | N/A              |
| Minimum dissolved oxygen level (mg/L) <sup>5</sup>   | 2.0                  | 2.0                  | 2.0              | 2.0              |
| Depth (feet)   | 6-15                 | 6-15                 | 6-15             | 6-15             |
| BOD <sub>5</sub> loading on aerated cells (pound/acre/day)   | 30-100               | 30-100               | 30-100           | 30-100           |
| Minimum detention time under aeration (days) <sup>6</sup>  | 20                   | 20                   | 15               | 15               |
| Emergency storage for infiltration/percolation (days)  | N/A                  | N/A                  | 30-90            | N/A              |
| Winter storage for irrigation or complete retention  | N/A                  | N/A                  | See <sup>7</sup> | See <sup>7</sup> |

- Notes:**
1. Outlet area of all final cells must have a quiescent zone to settle solids.
  2. One aeration cell if large storage cell is proposed. Two aeration cells if infiltration/percolation is proposed.
  3. If first cell is out of service, sufficient oxygen must be dispersed in remaining cells to keep cells aerobic.
  4. Oxygen supplied must be sufficient to meet the organic, nitrogenous, benthic, and algal demands in the pond.
  5. Measured 2 feet below the surface of the pond.
  6. Detention time must be sufficient to provide adequate BOD reduction to meet waste discharge requirements. Volume is calculated from 2 feet from the bottom to maximum depth. Time not inclusive of quiescent zone; waste load and climatic conditions may require more stringent criteria.
  7. A month-by-month water balance must be submitted with each land application or total retention disposal plan to determine winter storage.

**5070-4. Wastewater Systems Appurtenances**

- 4.1. All lagoons shall have an influent manhole so that influent flow measuring devices can be installed.
- 4.2. It is recommended that there be a hand-cleaned or mechanically cleaned bar screen on the upstream side of the influent manhole.
- 4.3. The waste stabilization pond (for nonaerated lagoons) shall have a maximum water depth of 5 feet.
- 4.4. The area of the lagoons will be governed by both organic and hydraulic loading limits. The total lagoon system shall be capable of holding the design flow for 180 days, including water losses and evaporation.
  - 4.4.1. Design for no more than 0.5 pounds of biochemical oxygen demand (BOD) per 1,000 square feet of water surface area per day.
  - 4.4.2. Fencing is required around all lagoons and must consist of chain-link fencing with a 3-strand barbed wire on top for an overall height of 6 feet. A 12-foot access gate and a 3-foot man gate are required.
- 4.5. No wastewater effluent shall be sprayed from a wastewater system upon a public street. A minimum setback of 25 feet shall be maintained from any surface application area to an adjoining public street, public property, or another person's property.
- 4.6. Lagoons (aerated or nonaerated) that discharge to state water shall be designed to a minimum of 80 percent BOD removal. Nondischarge lagoons are recommended wherever possible.
- 4.7. Use of wetlands for discharge is a possible disposal for a treatment process. However, due to maintenance considerations, this is not a preferred discharge method unless approved by the BIA.

**5070-5. Alternative Treatment Facilities**

- 5.1. Design of individual on-site treatment/disposal facilities should conform to the applicable criteria as set forth by the governing state Public Health Department and to local board of health requirements. Use of individual on-site treatment/disposal facilities is not a preferred alternative and should be considered only for small system design with approval of the BIA.
- 5.2. Packaged sanitary treatment systems may be an option, but are not recommended unless specifically approved by the BIA.
- 5.3. **Septic Tank/Leach Field Systems Design Criteria (First Stage Treatment Unit)**
  - 5.3.1. The inlet invert shall be at least 3 inches higher than the outlet invert.



- 5.3.2. The outlet tee or baffle shall extend above the surface of the liquid to within 1 inch of the underside of the tank top and shall extend at least 14 inches below the outlet invert.
- 5.3.3. The distance from the outlet invert to the underside of the tank top shall be at least 10 inches.
- 5.3.4. A 1,250-gallon, two-compartment tank is the minimum size allowable.
- 5.3.4.1. The transfer of liquid from the first compartment to the second shall be made at a liquid depth of at least 14 inches below the outlet invert, but not in the sludge zone.
- 5.3.4.2. At least one access no less than 24 inches across shall be provided in each tank compartment.
- 5.3.5. Septic tank leach fields shall be located no closer than 200 feet from any potable water source.
- 5.3.6. A septic tank manhole opening cover shall be no deeper than 8 inches below the finished grade, and made of materials resistant to degradation from moisture or sewer grades.
- 5.3.7. The replaced leach field area shall be located on-site in the original design unless an alternative site was originally anticipated and sufficient area is available.
- 5.3.8. *Aerobic Sewage Treatment System Within Septic Systems*
- 5.3.8.1. This shall prevent excessive short-circuiting flow, and deposition and buildup of solids in the aeration compartment, as well as allow for intimate mixing of applied sewage, return solids, and applied air.
- 5.3.8.2. Aeration methods are either mechanical aeration or diffused air, or a combination of both.

#### 5.4. Second Stage or Later Treatment Unit

##### 5.4.1. *Soil Absorption System (General)*

- 5.4.1.1. Calculate the minimum absorption area based upon the amount of suitable soil and the capacity of the soil to absorb liquids (determined by a percolation test), design criteria, and construction standards for this type of absorption system.
- 5.4.1.2. Soil absorption systems are not permitted in areas exhibiting any of the following conditions, unless designed by a registered professional engineer and approved by the local board of health (if regulations of the local board of health for such systems treat exclusively domestic wastes):
- Where the soil percolation rate is slower than 1 inch in 60 minutes or faster than 1 inch in 5 minutes; if the percolation

rate is faster than 1 inch in 5 minutes in soils of sandy texture, soil treatment may slow the percolation.

- Where the maximum seasonal level of the groundwater table is less than 4 feet below the bottom of the proposed absorption system.
- Where bedrock exists less than 4 feet below the bottom of the proposed absorption system.

**5.4.1.3.** Suitable soil requirements may be met by soil building or replacement.

#### **5.4.2. Absorption Area Formulas**

**5.4.2.1.** The minimum absorption area for an individual sewage disposal system can be calculated using the following formula. The minimum “t” value is 5.

$$A = \frac{Q}{5} \sqrt{t}$$

where:  $A$  = minimum absorption area (square feet)  
 $Q$  = design flow of sewage (gallons per day)  
 $t$  = percolation rate (minutes per inch)

**5.4.2.2.** Long-term acceptance rates (LTARs): The minimum absorption area may also be computed as a function of the design flow and the LTAR according to the formula below. (LTAR values are listed in Figure 5070-3):

$$A = \frac{Q}{L * T * A * R}$$

Figure 5070-3: LTARs for Wastewater Soil Absorption Systems

| Percolation Rate (Minutes/Inch) | Typical Soil Textures      | Maximum Loading Rate (Gallons/Square Feet/Day) |
|---------------------------------|----------------------------|--|
| <5**                            | Gravel**                   | Not suitable                                   |
| 1–5                             | Coarse to medium sand      | 1.30   |
| 6–10                            | Fine sand to loamy sand    | 1.20   |
| 11–20                           | Sandy loam to loam         | 0.72   |
| 21–30                           | Loam                       | 0.50   |
| 31–40                           | Loam to silty loam*        | 0.40   |
| 41–60                           | Clay loam to clay*         | 0.30   |
| Over 60**                       | Silty clay loam/silty clay | 0.20   |

\*Soils without highly expansive clays

\*\*Design by registered professional engineer required

**Note:** Percolation rates faster than 5 minutes per inch require a professional engineer design.

#### 5.4.3. Allowable Absorption Area Reductions and Increases

- 5.4.3.1. Adjustments must meet local health department criteria.
  - 5.4.3.2. Maximum daily flow reduction for design purposes is 20 percent; lower values may be determined by the local health officer or his/her agent.
  - 5.4.3.3. Reduction in the soil absorption area may be allowed for gravelless soil absorption systems with approval of the health department and at the discretion of the local health officer or his/her agent.
  - 5.4.3.4. The absorption area should be increased by an additional 20 percent if wastes from a garbage grinder are discharged into the system; add an additional 40 percent if wastes from an automatic clothes washing machine are discharged into the system.
  - 5.4.3.5. The maximum reduction in size of absorption area from all combined alternatives is 50 percent of the standard required soil absorption area.
- 5.4.4. **Alternating Systems.** The use of alternating systems is preferred. In alternating systems, the diversion mechanism shall be readily accessible from the finished grade and shall be switched annually. Reductions in absorption field area are not applicable to alternating systems; flow reductions may be taken where applicable.
- 5.4.5. Dosing may be used in conjunction with soil absorption systems, and the frequency can be calculated using the values in Figure 5070-4.

**Figure 5070-4: Suggested Dosing Frequencies for Soil Textures**

| Soil Texture    | Dosing Frequency        |
|-----------------|-------------------------|
| Sand            | 4 doses/day             |
| Sandy loam      | 1 dose/day              |
| Loam            | Frequency not critical* |
| Silty loam      | 1 dose/day              |
| Silty clay loam | 1 dose/day              |
| Clay            | Frequency not critical* |

\* Long-term resting provided by alternating fields is desirable and recommended in these soils.

#### 5.4.6. Absorption Area Construction

- 5.4.6.1. An absorption trench or seepage bed shall provide the required absorption area. The bottom of the trench or bed and distribution lines shall be level.
- 5.4.6.2. The separating distance between soil absorption systems shall be a minimum of 6 feet sidewall to sidewall. The separating distance between parallel distribution lines in a seepage bed shall not exceed 6 feet, and a distribution line shall be located within 3 feet of each sidewall of the seepage bed.
- 5.4.6.3. Perforated distribution pipe shall be placed the entire length of the trench or bed, surrounded by clean graded gravel, rock, or material of equal efficiency, which may range in size from 1/2 inch to 2½ inches and shall be placed from at least 2 inches above the top of the distribution pipe to at least 6 inches below the bottom of the distribution pipe. Tile or open joint pipe shall not be used.
- 5.4.6.4. Pipe for gravity distribution shall be no less than 3 inches in diameter and preferably less than 100 feet in length. The terminal ends of lines shall be capped unless looped or air vented.
- 5.4.6.5. The top of the placed gravel or other material used shall be covered with a layer of hay, straw, or similar pervious material. An impervious covering shall not be used.
- 5.4.6.6. A final cover of soil at least 10 inches deep, suitable for vegetation, shall be placed from the top of the hay, straw, or similar pervious material to the finished surface grade of an absorption trench or seepage bed. The final cover shall be graded to deflect runoff water away from the disposal area.
- 5.4.6.7. Machine tamping, rolling, or hydraulic compaction of final cover shall not be permitted; however, hand tamping may be allowed where necessary to stabilize the soil to prevent erosion or the intrusion of extraneous water.

**5.4.6.8.** If dosing is used in conjunction with an absorption trench or seepage bed system, the dosing chamber shall be sized to account for the volume of the distribution system and the dosing frequency.

**5.4.7. *Serial Distribution System.*** A serial distribution system may be used in all situations where a soil absorption system is permitted and shall be used where the ground slope exceeds 30 percent and does not allow for suitable installation of a single-level absorption field, unless a distribution box or dosing chamber is used. The horizontal distance from the side of the absorption system to the surface of the ground shall be adequate to prevent lateral flow and surfacing of effluent above ground. When a serial distribution system is used, the following design and construction procedures shall be followed:

- The bottom of each absorption field and its distribution line shall be level.
- There shall be a minimum of 10 inches of soil cover over the gravel fill.
- An absorption field shall parallel as closely as possible the ground surface contours to minimize variation in absorption field depth.
- There shall be a minimum of 6 feet (horizontal measurement) of undisturbed earth between adjacent absorption field trenches and between the septic tank or other treatment unit and the nearest absorption field.
- Adjacent absorption fields shall be connected with a relief line or a drop box arrangement such that each trench fills with effluent to the top of the gravel before flowing to succeeding trenches.

**5.4.8. *Evapotranspiration Disposal of Effluent.*** An evapotranspiration system may be used exclusively or in combination with a soil absorption system.

**5.4.8.1.** An evapotranspiration system shall be designed by a registered professional engineer who shall furnish design data for a complete review of the design.

**5.4.8.2.** Data to be furnished shall include, but shall not be limited to, liner material and bedding, properties of the soil in the evapotranspiration bed, evaporation and moisture data, and provision for vegetation cover.

**5.4.8.3.** When a high groundwater table, bedrock, fractured rock, or highly pervious material (percolation faster than 5 minutes per 1 inch) endanger the underground water, a durable and impermeable liner shall be installed to prevent the sewage effluent from entering the underlying formation or groundwater table.

**5.4.8.4.** An evapotranspiration system shall be located in an area where there is exposure to sunshine.

- 5.4.8.5. The system bed shall be crowned and covered with a minimum of 4 inches of selected backfill material and with a vegetation cover.
- 5.4.8.6. The bed area shall be protected to prevent damage from vehicular or pedestrian travel. The ground surface shall be graded to deflect precipitation and other outside water away from the disposal area.
- 5.4.8.7. The following formula may be used as a guide for determining the area necessary for total evapotranspiration of septic tank effluent:

$$\text{Area (in square feet)} = \frac{\text{Design Flow (in gallons per day)} \times 586}{\text{Lake Evaporation Rate at the Site (in inches per year)}}$$

- 5.4.8.8. As an alternative, a system may be designed on the basis of a monthly water balance for the system. Such a design provides for total storage of average daily flows for all periods in which evapotranspiration is not shown to occur. The design shall also provide wicks (sand structures that penetrate through the rock media to the bottom of the bed) equal to 10 to 15 percent of the bed surface area. The wicks shall be uniformly spaced throughout the bed. Adequate surface area shall be provided to evaporate/transpire total annual average daily flows at a rate equivalent to local net lake evaporation over the remainder of the year. (If the system is designed as a percolation/evapotranspiration system, the storage and evapotranspiration capacities may be reduced by the volume of effluent percolating into the soil.)
- 5.4.8.9. Sand utilized in evapotranspiration or evapotranspiration/absorption beds for cover shall meet the gradation requirements provided in Figure 5070-5 and be approved by the Designer of Record:

**Figure 5070-5: Gradation Requirements**

| Sieve Size | Percent Passing |
|------------|-----------------|
| 4          | 100             |
| 40         | 50–55           |
| 200        | <15             |

- 5.4.9. **Mound Systems.** A mound soil absorption system shall be designed by a registered professional engineer. The design shall be site specific and include specifications for fill material, base area size calculations, absorption area calculations, distribution networks, cap, topsoil, final grading, and other information pertinent to the construction of the system as may be requested by the health officer or his/her designated representative.

- 5.4.9.1. The distribution system shall be designed for uniform effluent application throughout the mound.
  - 5.4.9.2. The effluent distribution system shall be graded to drain back to the dosing chamber or to be buried below the frost line.
  - 5.4.9.3. The final slope of the mound backfill shall be no greater than 3 in 1 (3 feet horizontally in one 1 foot vertically).
  - 5.4.9.4. The mound shall be planted with suitable vegetative cover.
- 5.4.10. **Gravelless Soil Absorption System.** All gravelless soil absorption systems shall be approved by the local department of health. Where permitted by the local board of health, these systems shall be limited to only those absorption area reductions given through the health department's certification. The absorption area of a chamber-type absorption system shall be equivalent to the footprint of the interior of the chamber (interior base area).
- 5.4.11. **Constructed Wetland Treatment.** Due to higher maintenance needs, constructed wetland treatment is not a preferred method. Use of this method of treatment must be approved by BIA. A constructed wetland treatment system shall be designed by a registered professional engineer. The design shall be site specific and include specifications for loading, capacity, liner material, filter media, density and species of plant material, effluent level, final discharge type, and other pertinent information as requested by the health officer or his/her designated representative. The design shall include estimates of effluent quality at the inlet and outlet. Sampling ports, or some other means of effluent sampling, are needed to demonstrate compliance with discharge guidelines.
- 5.5. **Additional Design Criteria (Other Facilities)**
- 5.5.1. **Graywater System.** A graywater system shall meet at least all minimum design and construction standards for a septic tank system based on the amount and character of wastes for the fixtures and the number of persons to be served.
  - 5.5.2. Any graywater reuse should be appropriately signed and safety measures used to mitigate potential cross-connection.

## 5070-6. Wastewater Collection

- 6.1. Prior to acceptance of any sewer line, the contractor shall be required to clean all lines under hydrostatic pressure to remove any stoppage or dirt from the lines.
- 6.2. **Plan-Profile Drawing Stipulations**
  - 6.2.1. Existing waterlines and sanitary sewers and new waterlines should be shown from the point of connection. In addition, necessary valves, fire

hydrants, ground storage tanks, pump stations, etc., as well as all pipe sizes should be indicated.

- 6.2.2.** Alignment, depth, flow direction, and size of all sanitary sewer lines should be determined and plotted. Also indicate location, elevation, and depth of manholes, catch basins, and water valves (horizontal and vertical).
- 6.2.3.** The preferred location of sewer mains is parallel to roadway right-of-way or curb line 10 feet outside of pavement edges. Prior to locating sewer mains within the roadway, a benefit versus long-term maintenance cost analysis must be submitted to and approved by the BIA. See further discussion in Paragraph 6.2.4.
  - 6.2.3.1.** Elevations should be indicated to the nearest 0.01 foot.
  - 6.2.3.2.** No planting of trees or placement of structures shall be allowed within 10 feet of either side of the sanitary sewer main.
  - 6.2.3.3.** Provision for marking sanitary structures and special fittings must be made.
- 6.2.4.** If the BIA approves the location of sewer mains within the roadway, the sewer mains should be a minimum of 4 feet from the outside of the pipe to the lip of the curb in the middle of the roadway section. If possible, sewer pipes should be located on the centerline.
- 6.2.5.** The BIA will consider topography in relation to layout and long-term maintenance when sewer mains are connected to existing systems.
- 6.2.6.** Show the existing ground profile and the inverts of sewer lines between manholes. Horizontal angular deflections should not be less than 90 degrees. The horizontal scale on profiles should not exceed 1 inch equals 100 feet, and the vertical scale should not exceed 1 inch equals 10 feet. Drawings should show location, size, material, type of pipe, service lines, cleanouts, lift stations, outfall sewer line, and treatment facility.
- 6.2.7.** Service lines connect the building piping to sanitary collection mains. No design analysis of gravity building connections is required unless the sewage flow exceeds the capacity of a 6-inch pipe on a 0.6 percent slope.
- 6.2.8.** Sewer lines shall be buried at a minimum of 2 feet of cover not subjected to vehicle loads; if exposed to traffic, a minimum of 3 feet of cover shall be maintained.
- 6.2.9.** Lift stations and treatment systems should be detailed, including a schematic flow diagram, all system mechanical equipment and interconnecting piping (all dimensions to the nearest inch), and an electrical schematic showing wiring and associated electrical equipment.



### 6.3. Design Flow Calculations

- 6.3.1. Where more than one building is involved, use gravity sewers. No more than one building will be allowed on a service line.
- 6.3.2. Pipe sizing is determined by Manning's formula. For gravity flow computations, use  $n = 0.014$  for 12-inch or smaller pipe, and  $n = 0.013$  for pipe larger than 10 inches.
- 6.3.3. To minimize excavation, locations of sewer piping should be determined by the topography of the site.
- 6.3.4. Sewer pipes should be a minimum of 8 inches in diameter and designed to run not more than 80 percent full.
- 6.3.5. The slope should provide a velocity of at least 2.5 feet per second at full flow and 2.0 feet per second at the average flow rate.
- 6.3.6. Pipe materials should be chosen based on structural loads, soil conditions, and characteristics of transported wastes. Pipe, bonding agent, and fittings should all be compatible. Polyvinyl chloride (PVC) plastic pipe is typically the most desirable for sewer systems and is preferred by the BIA. PVC shall conform to ASTM D3034, SDR 35 or 26 as the standard construction material. Use ductile iron pipe (DIP) or PVC pressure-rated pipe for force mains and other specialized piping. All pipe should be installed according to the manufacturers' recommendations.
  - 6.3.6.1. PVC pipe should be placed in 20-foot lengths (plus or minus 1 inch) for all sizes.
  - 6.3.6.2. Perforated distribution pipe surrounded by rock within a soil absorption system should conform to ASTM D2729.
  - 6.3.6.3. Open-joint pipe, cast iron, and tile pipe will not be utilized in individual sewage disposal systems.
- 6.3.7. Gravity sewer mains conveying raw sewage should have a minimum diameter of 8 inches; building service connections should have a minimum diameter of 4 inches.
- 6.3.8. Sewer services shall be installed perpendicular, not parallel, to the right-of-way.
- 6.3.9. Minimum grades are shown in Figure 5070-6.

**Figure 5070-6: Minimum Gravity Sewer Main Grades**

| Pipe Diameter   | Minimum Grade |
|-----------------|---------------|
| 101 mm (4 in.)  | 1.0%          |
| 152 mm (6 in.)  | 0.6%          |
| 203 mm (8 in.)  | 0.45%         |
| 254 mm (10 in.) | 0.28%         |
| 305 mm (12 in.) | 0.22%         |

**6.3.10.** All sewer mains should be installed at a uniform slope and with a straight alignment between manholes, which are to be installed at the end of each line.

**6.3.11. Manholes**

**6.3.11.1.** Use eccentric cones with a minimum internal diameter of 48 inches. For frames and covers, minimum access diameter is 22 inches, and minimum weight is 350 pounds. Use of different manhole sizes and types shall be allowed only upon written approval from the BIA.

**6.3.11.2.** Use a drop structure if the drop of the mainline sewer through the manhole exceeds 12 inches in diameter or if the sewer enters a manhole 2.0 feet or more above the manhole invert.

**6.3.11.3.** Space manholes at no more than 400 feet apart.

**6.3.11.4.** Provide 0.2-foot fall from the flowline inlet to the flowline outlet within the manhole.

**6.3.11.5.** Manhole steps shall be noncorrosive, 12 inches in width, manufactured of either aluminum or 0.5-inch steel rod encased with polypropylene. Steps shall be staggered 16 inches on center, withstand vertical loads of 400 pounds, and have a pull-out resistance of 1,000 pounds.

**6.3.12.** Service connections should use a wye branch to connect building services to the main sewer lines.

**6.3.13.** Cleanouts should be installed in the building service sewer every 100 feet, and at other appropriate locations.

**6.4. Sewage Lift Stations and Force Mains**

**6.4.1.** If gravity sewers cannot be provided, sewage pumps shall be installed in a sewage lift station constructed on the lowest terrain in the vicinity. The required pumping capacity, wastewater characteristics, lift station/force main hydraulic profile, pump and equipment characteristics, and design preferences should be submitted to the BIA prior to lift station design.

**6.4.2.** Lift stations may be pre-manufactured if approved by the BIA prior to design. Otherwise, lift stations will require a pump house design meeting architectural requirements acceptable to the BIA.

**6.4.3. *Design Criteria***

- 6.4.3.1.** Either the wet well/dry well type or submersible lift stations are acceptable. Wet well/dry well may be either above ground or below ground. However, above-ground systems are preferred.
- 6.4.3.2.** Design to allow removal of pumps and motors without entry into the wet well.
- 6.4.3.3.** Components should be easily maintained, sampled, drained, pumped, inspected, and cleaned.
- 6.4.3.4.** Use the following equation to calculate the volume ( $V$ ) of the wet well between start and stop elevations:

$$V = \frac{T * Q}{4}$$

where:  $V$  = volume in gallons  
 $T$  = the minimum recommended cycle time (minutes) between pumping cycles  
 $Q$  = the maximum pumping capacity (gallons per minute) of one pump

- 6.4.3.5.** Specify a minimum of duplex pumping units (equipped for automatic alteration). Use a design cycle time of 10 minutes (6 starts per hour per pump).
- 6.4.3.6.** Design a drawdown distance between start and stop points of between 12 inches and 39 inches.
- 6.4.3.7.** Shutoff and ball check valves should be provided on the discharge line of each pump, both located outside the wet well in an appropriately sized vault with adequate access. The check valves shall be suitable to handle raw sewage and are to be placed between the pump and shutoff valve.
- 6.4.3.8.** Ventilate all lift stations and equip them with audible and visual alarms that activate in the event of power failures, pump failures, unauthorized entry, and the use of the lag pump when the lead pump is running.
- 6.4.3.9.** Backup power is required for all sanitary lift stations. With a backup power supply, provide a minimum of 30 minutes of additional storage. Noise abatement is required to maintain decibel levels at existing background levels unless otherwise allowed by the BIA. If

backup power is not required by the state or local jurisdiction and if the BIA grants a waiver of the backup power requirement, provide a minimum of two hours of additional storage or as required by the state health department.

- 6.4.3.10. The electrical control panel should be a 14-gauge minimum thickness prewired NEMA 4 weatherproof/dustproof steel enclosure with a swing dead front cover and lock hasp. For each pump, supply a circuit breaker, magnetic starter with a 3-leg overload protection for 3-phase operation, hand-off-auto (H-O-A) switches, running time meters measuring hours and tenths, a red “pump failure” lamp, a green “pump running” lamp, and elapsed time meters.
- 6.4.3.11. Design of all pumps and electrical equipment in wet wells is to comply with the National Electrical Code for Class I, Group D, Division 1 locations.

#### 6.4.4. *Force Mains*

- 6.4.4.1. Force mains should be a minimum of 4 inches in diameter to mitigate plugging.
- 6.4.4.2. Use a velocity of 3.5 to 5.0 feet per second in designing the force main. Velocities outside this range are not allowed without approval and should never go below 2 feet per second.
- 6.4.4.3. Force mains should enter a gravity sewer manhole at a point no more than 2 feet above the flowline of the receiving manhole and shall have a baffle device.
- 6.4.4.4. Force mains shall be PVC pipe conforming to ASTM D2241, adequate for the pressure developed by the pump system.
- 6.4.4.5. Consideration should be given to the maximum time sewage will remain in the system and every effort made to avoid a septic condition.

#### 6.4.5. *Lift Station Pumps*

- 6.4.5.1. End suction pumps: Verify positive suction and priming capability.
- 6.4.5.2. Submersible: These pumps should pass 2-inch solids, minimum.
- 6.4.5.3. Lift station pumps shall be sized to accommodate the minimum velocities in force main piping while minimizing horsepower, minimizing rpm, and providing the best efficiency possible. The motor shall be non-overloading.

**5080-1. General**

- 1.1. This section includes general minimum requirements, criteria, and guidance for the planning and design of storm drainage for BIA Justice / Detention facilities. All planning and design must provide control of storm drainage to protect the health, safety, and welfare of the facility and its occupants. Proper planning and design shall ensure that the facility is sufficiently above floodplains, does not interfere with existing drainage patterns, and does not contribute to or cause downstream flooding conditions. Design of all new construction shall be in conformance with this guideline, except as noted in paragraph 1.3.
- 1.2. Additional design and submittal requirements may be required for projects with unusual or more demanding site conditions.
- 1.3. The Designer of Record of the storm drainage facilities should be an active registered professional engineer in the state of the proposed Justice / Detention project and should be knowledgeable in local and federal drainage practices. Due to the variety of design situations, these guidelines are adjustable under the correct circumstances. In the event these guidelines do not apply to particular site conditions, provide a written explanation to the BIA and an appropriate substitute design narrative and/or calculations.

**5080-2. Drainage Report****2.1. Submittal Requirements**

- 2.1.1. A drainage report must be developed by the Designer of Record that includes a narrative and the calculations necessary for the proposed drainage system. At a minimum, two submittals will be required, a preliminary drainage report and a final drainage report. These drainage reports shall be submitted with accompanying drainage plan(s) (map). Drainage reports shall be prepared on 8½ -inch-by-11-inch paper and suitably bound. The drainage plan may be either folded and bound with the report or folded and placed in a pocket that has been bound within the report. Two copies of these documents shall be submitted for review and approval by the BIA.

**2.2. Preliminary Report**

- 2.2.1. Prior to the approval of preliminary site plans, a preliminary drainage report for the project must be submitted and approved. The preliminary drainage report shall include preliminary drawings of all proposed drainage facilities, applicable drainage studies and reports, design computations, and such information as may be required to ensure that storm water originating from both the proposed facility and the lands lying upgradient from the facility will be adequately drained and controlled. The purpose of the preliminary report is to identify and define drainage problems associated with the proposed development and to define conceptual solutions.

### **2.3. Final Report**

- 2.3.1.** Prior to the final approval of the project construction plans, the Designer of Record shall, at their expense, prepare and submit for review and approval by the BIA a final drainage report, which shall include detailed construction drawings, plans, profiles, and specifications for the construction and installation of all drainage facilities necessary for the drainage and control of all storm water within the facility property and the conveyance of such water to a safe discharge or outflow point. The purpose of the final report is to translate the preliminary plan from a conceptual plan to a constructible plan. Such plan shall conform to the approved preliminary plans and reports and include all updates and changes requested by the BIA. Prior to the construction of any on-site improvements, the Designer of Record must obtain all necessary local, state, tribal, and/or federal permits.
- 2.3.2.** The BIA will review and make any comments deemed necessary on the submitted drainage report and drainage plan and return those copies to the Designer of Record. When the drainage report is deemed acceptable by the BIA, two additional copies of the drainage report and drainage plan must be submitted for the BIA's record copy.

### **2.4. Report Narrative**

- 2.4.1.** The drainage report should include a narrative followed by an appendix with relevant calculations necessary for the proposed drainage system. At a minimum, the narrative should:
- 2.4.1.1.** State the proposed land use.
  - 2.4.1.2.** Give the general location and a description of the site. At a minimum, the name of the state, county, reservation, and where possible, township, range, and section. Define the area (in acres) of the site, in particular the area that will be disturbed by construction. Describe the relative locations of all state highways and/or local streets that provide access to the site.
  - 2.4.1.3.** Show the above street and highway information on an 8½ -inch-by-11-inch vicinity map within the report's appendix. The scale of the vicinity map should be appropriate to show the location of the project within the reservation with roads/highways leading up to the reservation.
  - 2.4.1.4.** Describe existing drainage facilities and major streams or rivers in the project vicinity that may have impact on or be impacted by the Justice / Detention center or its proposed drainage facilities. This information should also be shown on the vicinity map.
- 2.4.2.** Describe existing ground cover, vegetation, and soil types, along with estimated runoff coefficients and infiltration opportunities.

- 2.4.2.1.** Describe historic drainage patterns in the area of the proposed development.
- 2.4.2.2.** Describe all irrigation facilities, both proposed and existing, that are located in or that may be affected by the project.
- 2.4.2.3.** Include all hydrologic and hydraulic design computations necessary to substantiate adequate sizing of all proposed drainage facilities. Describe and reference drainage analysis methodologies used in the report, including but not limited to the following:
- Design rainfall event(s), including the source of rainfall data used. The 10-year storm (initial event) and 100-year storm (major event) should be analyzed.
  - The runoff calculation method used (the Rational Method is suggested below).
  - Retention or detention and the storage calculation method used.
  - The methodology for determining proposed release rates from retention and detention ponds; describe any storm water that cannot practicably be detained.
- 2.4.3.** Description of the proposed drainage design should address the following:
- Major basins, including the effects of off-site tributary watersheds.
  - The boundaries of all sub-basin drainage areas on-site.
  - All conveyance elements, pipes, gutters, swales, culverts, overland flow, etc. Include their corresponding calculations, such as hydraulic grade line showing losses from friction, transitions, bends, junctions, and other losses, in the appendix.
  - Storm water collection inlets and other necessary storm water appurtenances.
  - Detention or retention, including available freeboard and proposed release structures.
  - Other proposed drainage facility design issues not described above.
- 2.4.4.** Present floodplain information for major drainage channels near or in the vicinity of the proposed facility, including:
- A FEMA Flood Insurance Rate Map (FIRM) in the appendix, if available.
  - A description of the site in relation to both the 500-year flood and 100-year flood. If a floodplain study has not been prepared for the channel, the designer should evaluate both the 100-year and 500-year floodplain elevations.

- Any other flooding issues not already discussed, such as (but not limited to) shallow flooding zones.

**2.4.5.** Conclusions: Describe in the conclusion section how the proposed drainage design complies with or varies from the storm drainage criteria found in this handbook.

## **2.5. Drainage Plan**

**2.5.1.** The drainage plan is a map or set of maps that graphically depict all elements of the drainage system described in the drainage report narrative. All elements shown on the drainage plan should coordinate with that narrative. Specifically, the drainage plan should include, at a minimum, the following:

**2.5.1.1. *Historic Drainage Plan.*** This is a scaled 24-inch-by-36-inch map that shows the following:

- Major basins, sub-basins, and drainage patterns on-site before the implementation and construction of the proposed development and their relation to the buildings and appurtenances on-site.
- Pertinent off-site drainage basins and drainage patterns that are tributary to the site.
- Existing drainage facilities and structures, including irrigation ditches, roadside ditches, crosspans, drainageways, gutter flow directions, and culverts. All relevant information such as material, size, shape, slope, and elevations should be shown.

**2.5.1.2. *Proposed Drainage Plan.*** This is a scaled 24-inch-by-36-inch map that shows the following:

- Major basins, sub-basins, and drainage patterns on-site after the implementation and construction of the proposed development and their relation to the buildings and appurtenances to be developed.
- Existing and proposed contours, shown at 2-foot-maximum intervals. In areas of little relief, 1-foot contours should be shown, and the existing contours should extend a minimum of 100 feet beyond the project limits.
- Property lines and easements, with purposes noted.
- Streets, indicating right-of-way width, flowline width, curb type, sidewalk, and approximate slopes.
- Proposed drainage facilities and structures and existing drainage facilities and structures not to be demolished, including irrigation ditches, roadside ditches, crosspans,



drainageways, gutter flow directions, and culverts. Include all pertinent information, such as material, size, shape, slope, and elevations.

- Proposed streets, ditches, gutters, and their slopes and flow directions.
- Proposed storm sewers and open drainageways, including inlets, manholes, culverts, and other appurtenances, including riprap scour protection.
- The proposed outfall point for runoff from the developed area and facilities to convey flows to the final outfall point without damage to downstream properties.
- Routing and accumulated flows at various critical points for the initial and major storm runoff (typically 10- and 100-year storms).
- Volumes and release rates for detention storage facilities and design information on their outlet works.
- Location and elevation of floodplains affecting the property.
- Pertinent off-site drainage basins and drainage patterns that are tributary to the site, along with the routing of these flows through or around the development.
- A legend to define map symbols, line types, etc.

### **5080-3. Drainage System Inspection**

**3.1.** A professional engineer of the Designer of Record shall inspect the constructed drainage system to confirm its conformance with the approved drainage plan design. The following elements should be verified:

- Proposed finished floor elevations
- Sizes, grades, locations, and elevations of drainage structures, channels, pipes, etc.
- Basin boundaries and high points with the design drawings
- Detention/retention pond volumes and outlet works
- Facilities appear to be constructed in a workmanlike manner and functional

### **5080-4. As-Built Plan**

**4.1.** Deviations from the approved drainage plan shall be annotated on the as-built plan.

**4.2.** The engineer shall include the following statement on the as-built plan:

I hereby declare that: I have performed a field review of the constructed drainage facilities on this plan, the facilities substantially conform to the approved drainage plan, appear to have been constructed in a workmanlike manner, and appear to be adequate for the intended purpose.

\_\_\_\_\_  
Registered P.E.      State of \_\_\_\_\_  
No. \_\_\_\_\_

### 5080-5. Drainage System Design

5.1. The drainage system Designer of Record should adhere to the following general guidelines:

5.1.1. Off-site flows are storm water flows entering the project area and shall be quantified and included in the drainage system design.

5.1.2. Drainage reports for off-site developed areas affecting the property shall be reviewed and considered in the drainage system planning and design.

5.1.3. Off-site flows should be received and discharged at locations existing prior to construction and in the manner that existed prior to construction.

5.1.4. Irrigation ditches should be considered full and should not be used to intercept or convey storm drainage. Wherever possible, storm waters are to be diverted around or away from irrigation ditches.

#### 5.1.5. *Floodplains*

- Floodplain limits shall be delineated by scaling distances from FEMA maps and by plotting the base flood elevation on existing topography.
- Areas projected for inundation by the 100-year flood shall remain free of all structures and shall be preserved in as natural a condition as possible.
- If the project alters or improves a major drainageway, the Designer of Record must revise the floodplain as part of the project.
- All plans, details, calculations, and other requirements must be reviewed by the BIA before the developer submits plans to FEMA.
- Proposals to channelize and encroach on major drainageways will be reviewed on a case-by-case basis.
- Where drainageways have been designed to remain in their natural state, encroachments or alterations will not be allowed.
- Setback requirements will be determined based on the potential erosion and stream bank failure hazards. A minimum setback of 15 feet for any structure is required, with greater setbacks required as conditions warrant.

**5.2. Hydrologic Calculations.** Calculations supporting the drainage system design should use the following methodology, where applicable. Alternative methodologies should be used by the Designer of Record where applicable and should be technically justified and fully documented within the appendix of the drainage report.

**5.2.1. The Rational Method.** Use this computation method, as shown below, to calculate peak flows at critical design points of the project drainage system. The Rational Method should be applicable for small basins of 130 acres or less. All drainage system components should be sized to convey peak minor storm flows computed using this method. The Soil Conservation Service (SCS) method should be used for basins of 130 acres or more. Consideration will be given to other methodologies on a case-by-case basis.

**5.2.1.1.** The time of concentration,  $t_c$ , consists of an initial or overland time ( $t_i$ ) plus the time of travel ( $t_t$ ).  $t_c$  represents the time necessary for the most remote raindrop in the basin to reach the design point.  $t_t$  consists of travel time in a storm sewer, paved gutter, roadside drainage ditch, drainage channel, swale, or other concentrated conveyance element.

$$t_c = t_i + t_t$$

The initial or overland flow time ( $t_i$ ) is calculated using the following equation:

$$t_i = \frac{1.8 * (1.1 - C_5) * L^{1/2}}{S^{1/3}}$$

where:  $t_i$  = initial or overland time (minutes)  
 $C_5$  = runoff coefficient for 5-year frequency storm  
 $S$  = average basin slope (percent)  
 $L$  = length of overland flow (feet, maximum)

**5.2.1.2.** When it is determined that overland flow is longer than 300 feet, the first 300 feet should use the equation above. Beyond this initial 300 feet, the flow should be analyzed using the travel time ( $t_t$ ) methods described below.

The velocity of flow can be computed using the hydraulic properties of the ditch, channel, curb and gutter, or storm sewer.  $t_t$  can then be computed in the following formula:

$$t_t = \frac{L}{60 * v}$$

where:  $t_t$  = travel time (minutes)  
 $v$  = velocity of flow (feet per second)  
 $L$  = distance of flow in hydraulic structure (feet)

$t_c$  shall be at least 5 minutes.

$t_c$  shall be the minimum of the following:

$$t_c = \frac{L}{180} + 10$$

where:  $t_c$  = time of concentration (minutes)

$L$  = length of flow to design point from the most remote point (feet)

or

$$t_c = t_i + t_t$$

- 5.2.1.3. Locally accepted runoff coefficients (Cs) should be used when available. If local runoff coefficients are not available, use the Cs shown in Figure 5080-1.

**Figure 5080-1: Alternative Runoff Coefficients**

| Location                  | Runoff Coefficient (C) |
|---------------------------|------------------------|
| <b>Business:</b>          |                        |
| Downtown areas            | 0.70–0.95              |
| Neighborhood areas        | 0.50–0.70              |
| <b>Residential:</b>       |                        |
| Single-family areas       | 0.30–0.50              |
| Multi-units, detached     | 0.40–0.60              |
| Multi-units, attached     | 0.60–0.75              |
| Suburban                  | 0.25–0.40              |
| Apartment dwelling areas  | 0.50–0.70              |
| <b>Industrial:</b>        |                        |
| Light areas               | 0.50–0.80              |
| Heavy areas               | 0.60–0.90              |
| Parks, cemeteries         | 0.10–0.25              |
| Playgrounds               | 0.20–0.40              |
| Railroad yard areas       | 0.20–0.40              |
| Unimproved areas          | 0.10–0.30              |
| <b>Lawns:</b>             |                        |
| Sandy soil, flat, 2%      | 0.05–0.10              |
| Sandy soil, average 2–7%  | 0.10–0.15              |
| Sandy soil, steep, 7%     | 0.15–0.20              |
| Heavy soil, flat 2%       | 0.13–0.17              |
| Heavy soil, average, 2–7% | 0.18–0.22              |
| Heavy soil, steep 7%      | 0.25–0.35              |
| <b>Streets:</b>           |                        |
| Asphaltic                 | 0.70–0.95              |
| Concrete                  | 0.80–0.95              |
| Brick                     | 0.70–0.85              |
| Drives and walks          | 0.75–0.85              |
| Roofs                     | 0.75–0.95              |

**5.2.1.4.** Local, state, or tribal regulatory agencies may have 1-hour intensity-duration-frequency (IDF) curves specific to the site, which should be used if available. If not, IDF curves may be extrapolated from the National Oceanic & Atmospheric Administration (NOAA) atlas using the processes described within the atlas.

**5.2.1.5.** The design runoff shall be calculated using the following equation:

$$Q = CIA$$

where:  $C$  = the runoff coefficient

$I$  = rainfall intensity derived from IDF curve (inches per hour)

$A$  = drainage area (acres)

$Q$  = design runoff (cubic feet per second)

**5.3. Site Grading.** Site grading shall be performed according to Section 5030.

Grading shall protect the project from all forms of flooding and should promote capture of as much runoff as practicable in the detention facilities. Specifically, grading shall closely adhere to the following constraints:

**5.3.1.** If the project is within a floodplain, the lowest floor, including the basement, must be elevated a minimum of 2 feet above the 500-year floodplain elevation. Habitable buildings shall not be located within the 100-year or 500-year floodplain.

**5.3.2.** Storm water from the Justice / Detention center and other associated facilities should flow to roadway ditches, swales, channels, or storm piping that conveys the flow to the detention facilities.

**5.4. Hydraulic Calculations.** Hydraulic calculations supporting the drainage system should be documented in the appendix of the drainage report and should address the following at minimum:

**5.4.1.** Streets should primarily be used for traffic. However, streets can be an integral part of the drainage system, provided:

- The initial storm does not produce runoff that will overtop the curb. Water may spread to the back of walks where mountable curb and attached walk are used. For mountable curb with detached walk, water may spread to the crown of the street, but no crown overtopping is allowed for the minor event.
- The maximum water depth at the crown of the road is not greater than 6 inches in a major event. Flows exceeding these criteria may warrant oversizing storm sewers or beginning an off-street open channel system.
- Parking lots, whether or not used as detention, have a maximum depth of 1 foot for a driving lane and 1 foot for a parking space.

- 5.4.2. Open Channels.** Open channels should be designed to integrate recreation and aesthetic needs, protect wildlife, support plant populations, and allow for bicycle and pedestrian trails. Open channels shall be designed for the 100-year storm, and effects of the 10-year storm should also be analyzed. Grass-lined channels and swales are preferred and shall be used unless physical restraints make their use unfeasible.
- 5.4.2.1.** Channels should be designed to avoid supercritical flows and flows near critical depth. The Froude number shall be less than 0.8.
  - 5.4.2.2.** Side slopes shall be as flat as practical. Side slopes of 4 in 1 or flatter shall be normally considered for all areas to be vegetated.
  - 5.4.2.3.** Trees and shrubbery shall not be permitted to grow in swales or major channels.
  - 5.4.2.4.** Whenever feasible, the design of wetland bottomed channels is encouraged to slow down runoff and allow time for settling and biological uptake.
  - 5.4.2.5.** Grass-lined channels should normally have a minimum slope of 2 percent. Where the natural topography is steeper than desirable, drops may be needed.
  - 5.4.2.6.** Avoid using concrete-lined channels.
  - 5.4.2.7.** Riprap-lined channels are permitted only in areas where space constraints prohibit the use of grass-lined channels. Riprap-lined channels shall be designed to have a Froude number of less than 0.8.
  - 5.4.2.8.** Except where localized overflow in certain areas is desirable for additional ponding benefits or other reasons, the minimum allowable freeboard shall be equal to the velocity head plus 0.5 feet.
  - 5.4.2.9.** For trapezoidal channels, the bottom width should normally be at least twice the depth of flow.
  - 5.4.2.10.** Trickle channels or underdrain pipes to carry low flows are suggested in grass-lined channels.
  - 5.4.2.11.** On larger swales located on sandy soils, a low-flow channel may be appropriate.
  - 5.4.2.12.** Trickle channels should be lined with riprap or other scour-resistant materials.
  - 5.4.2.13.** The maximum storm water velocity for the grass-lined swales should not exceed 5.0 feet per second in sandy soils, and should not be more than 7.0 feet per second for erosion-resistant soils. More stringent criteria may apply where soil conditions warrant. Channels shall be designed with proper and adequate erosion control features. Outlets from storm sewers, culverts, and tributary channels shall have

adequate riprap, cutoff walls, or other features to protect the outlet and the receiving channel from scour.

**5.4.2.14.** Proof of compliance with all applicable regulations, including Section 404 permits, are considered to be part of the design.

**5.4.3. Storm Sewers.** Storm sewers should adhere to the following:

**5.4.3.1.** Storm sewers shall be normally designed to convey minor storm flows without surcharging the sewer.

**5.4.3.2.** To promote self-cleansing, the minimum flow velocity in storm sewers shall be 2 feet per second.

**5.4.3.3.** The maximum velocity allowed in storm sewers shall be 20.0 feet per second.

**5.4.3.4.** Final design of storm sewers includes calculating the hydraulic and energy grade lines.

**5.4.3.5.** The energy grade line of all storm flows through pipes must be below proposed grade and manhole covers.

**5.4.3.6.** Storm sewer pipe shall not be less than 15 inches in diameter. Smaller pipe will be reviewed on a case-by-case basis.

**5.4.3.7.** Reinforced concrete pipe (RCP) should be used for all storm sewer pipes 18 inches or more in diameter.

**5.4.3.8.** Storm sewer pipe shall withstand HS-20 design loading in accordance with American Association of State Highway and Transportation Officials (AASHTO) *Standard Specifications for Highway Bridges* and with the pipe manufacturer's recommendation when the pipe is under roads or parking areas.

**5.4.3.9.** RCP shall be Class III or greater in all streets and tracts, regardless of whether or not heavy loads are expected.

**5.4.3.10.** Watertight rubber gaskets are required for all pipe joints.

**5.4.3.11.** Precast manhole sizes are based on the largest pipe size into or out of the manhole, assuming only one pipe in and one pipe out of the manhole. Increase precast manhole diameter to the next available size for each additional pipe entering the manhole. Figure 5080-2 shows manhole spacing and size.

**Figure 5080-2: Manhole Spacing and Size**

| Pipe Diameter or Vertical Rise  | Manhole Size | Maximum Manhole Spacing |
|---|--------------|-------------------------|
| 15"–18"   | 48"          | 400'                    |
| 24"   | 60"          | 400'                    |
| 36"   | 72"          | 400'                    |
| 48"   | 84"          | 500'                    |
| 60"   | 96"          | 500'                    |
| Larger pipes require special manhole design and will be reviewed on a case-by-case basis. |              | 500'                    |

- 5.4.3.12.** Horizontal alignment of pipe between manholes shall be straight.
- 5.4.3.13.** Manholes are required wherever there is a change in size, direction, elevation, grade, or at lateral storm sewer junctions. Manholes may be waived for a short lateral that has a diameter of less than half of the storm sewer trunkline.
- 5.4.3.14.** The minimum vertical separation to a water or sanitary sewer line is 18 inches. Lesser clearance requires concrete encasement or approved support for the affected utility.
- 5.4.3.15.** Approved erosion control shall be designed and installed at all storm sewer outlets.
- 5.4.4. Culverts.** A culvert is considered to be any structure that connects two open channels at a road crossing and should adhere to the following:
  - 5.4.4.1.** The culvert must convey 100-year flows.
  - 5.4.4.2.** The culvert, including inlet and outlet structures, shall convey water, sediment, and debris at all stages of flow.
  - 5.4.4.3.** The required headwater depth will be limited by upstream conditions, but should not exceed 1.5 times the culvert diameter or 1.5 times the culvert rise dimension for shapes other than round.
  - 5.4.4.4.** Excessive ponding above culvert entrances will not be acceptable if damage appears likely to surrounding property or to the roadway.
  - 5.4.4.5.** Culverts should be designed with an emergency overflow path above.
  - 5.4.4.6.** Culvert capacity should be analyzed using Bureau of Public Roads Hydraulic Engineering Circular No. 5. Both inlet and outlet control conditions should be analyzed.



- 5.4.4.7. Flared end sections or headwalls with wing walls are required on all culverts. Inlets are to be designed to minimize head losses. Scour protection is to be provided at all culvert outlets.
- 5.4.4.8. Culvert slopes shall prevent silting, yet avoid excessive velocities. Generally, the minimum culvert slope is 0.5 percent. Minimum barrel velocity is 3 feet per second and maximum is 21 feet per second.
- 5.4.4.9. Outlet velocities of all culverts must be checked. When outlet velocity exceeds maximum permissible channel velocity, energy dissipaters shall be provided to minimize potential erosion at the outlet.
- 5.4.4.10. Culverts shall be concrete unless otherwise approved by the BIA.
- 5.4.4.11. Culverts shall be designed to withstand H-20 loading in accordance with AASHTO *Standard Specifications for Highway Bridges* and with the pipe manufacturer's recommendation.
- 5.4.5. **Inlets.** Inlet design should adhere to the following:
  - 5.4.5.1. All inlets shall be designed to accept the minor storm after compensating for the effects of debris plugging. Inlets should generally be designed for 60 percent efficiency.
  - 5.4.5.2. The size of outlet pipes from storm water inlets shall be based upon the design flow rate at the inlet, but shall not be less than 15 inches in diameter.
  - 5.4.5.3. An emergency overflow must be provided for all inlets in a sump condition. All emergency overflows shall be designed for a 100-year storm, assuming that storm sewer pipes are plugged.
  - 5.4.5.4. Inlets shall be normally located in a low point, or at a point on a continuous grade where the initial storm runoff exceeds the curb capacity of the street.
- 5.4.6. **Storm Water Quality Control.** Storm water quality control measures must be developed and implemented by the Designer of Record in conjunction with the overall drainage plan for the site. Water quality ponds reduce the amount of sediment released into downstream drainage channels.
  - 5.4.6.1. Infiltration-type structural best management practices (BMPs) shall be designed to capture and treat the first 1/2 inch of rainfall from the development. The following formula calculates water quality control volume:

$$WQCV = (A * I * \frac{1}{24})$$

where:  $A$  = developed watershed area (acres)  
 $I$  = percent impervious of the developed area (expressed as a decimal)  
 $WQCV$  = water quality control volume (acre-feet)

- 5.4.6.2. Designers are required to add half of the minimum water quality control volume to the detention volume when detention and water quality ponds are combined. The full water quality control volume must be captured for water-quality-only ponds.
- 5.4.6.3. Improved water quality should be attained by allowing sediment to settle to the bottom of the water quality pond before storm water is released from the pond. It is recommended that this be done through an outlet structure inside the water quality pond. For outlet structure design considerations, see below.
- 5.4.6.4. Trickle channels should not be used for ponds whose sole purpose is to provide water quality.
- 5.4.7. **Detention/Retention.** On-site detention or retention is required for all Justice / Detention Center projects. In some cases, full retention of storm drainage may be necessary. Exemption from the detention requirement may be allowed by the BIA if storm runoff is discharged directly into a regional detention pond sized to accommodate developed flows from the project area.
  - 5.4.7.1. Detention should be provided by means of open-space or parking lot detention.
  - 5.4.7.2. Underground detention may be used as a last resort, when all other alternatives are exhausted.
  - 5.4.7.3. Rooftop detention is not allowed.
  - 5.4.7.4. Parking lot detention may be used provided the maximum water depth does not exceed 12 inches.
  - 5.4.7.5. Where possible, utilize multi-purpose sports fields or landscaped areas to supplement the volume of a detention pond, provided maximum standing water depths are limited to 12 inches, the sports field is graded to rapidly shed water as the detention pond recedes, and the lowest part of the pond is substantially separated from the field to minimize periods of standing water on the field.
  - 5.4.7.6. Open ponds should be planted with resilient native grasses that can sustain frequent soggy and dry periods.
  - 5.4.7.7. To minimize standing water, detention ponds should be able to completely drain within 40 hours.

- 5.4.7.8.** Detention pond storage shall be designed for both the 10-year and 100-year events. Required detention volumes may be determined using  $V = KA$ , where  $V$  equals the detention volume for the design storms in acre-feet and  $A$  is the tributary area in acres.

$$\text{For the 100-year storm } K_{100} = \frac{1.78I - 0.002I^2 - 3.56}{1000}$$

$$\text{For the 10-year storm } K_{10} = \frac{0.95I - 1.90}{1000}$$

where:  $I$  = tributary basin's composite imperviousness percent

- 5.4.7.9.** Alternate methods for computing detention volumes can be found in the Federal Highway Administration's Hydraulic Engineering Circular No. 22.
- 5.4.7.10.** Allowable release rates in cubic feet per second (cfs) from the ponds for the 10- and 100-year storms can be computed from the ratios shown in Figure 5080-3. The predominant National Resources Conservation Service (NRCS) or SCS soil group for the total basin area tributary to the detention pond shall be used for determining the allowable release rate.

**Figure 5080-3: Allowable Release Rates (CFS/Acre)**

| Storm Frequency | SCS Hydrologic Soil Group |      |         |
|-----------------|---------------------------|------|---------|
|                 | A                         | B    | C and D |
| 10-year         | 0.13                      | 0.23 | 0.30    |
| 100-year        | 0.50                      | 0.85 | 1.00    |

- 5.4.7.11.** The allowable release rates for all other methods shall be the historic undeveloped flow rates from the tributary basin area.
- 5.4.7.12.** Available pond volume shall be calculated using the following formula:

$$V = \sum \frac{(A1 + A2 + (A1 * A2)^{1/2}) * Depth}{3}$$

where:  $A1$  = contour area at Elevation 1  
 $A2$  = equals contour area at Elevation 2  
 $Depth$  is equal to Elevation 2 – Elevation 1

- 5.4.7.13.** The pond bottom shall include a trickle channel having a capacity at least 3 percent of the inflow discharge. The longitudinal slope for trickle channels shall be at least 0.5 percent. The pond bottom

cross-slope shall be at least 2 percent.

- 5.4.7.14. Access ramps to the pond bottom shall be provided for maintenance.
  - 5.4.7.15. Access ramps must be at least 8 feet wide with a 10 percent or flatter longitudinal slope.
  - 5.4.7.16. The ramp need not be paved, but must be of all-weather construction and capable of sustaining loads caused by maintenance equipment.
  - 5.4.7.17. Retention pond volumes should be calculated based on methods from local jurisdictional criteria or from Hydraulic Engineering Circular No. 22.
  - 5.4.7.18. The minimum freeboard for open-space detention or retention facilities is 1 foot above the computed 100-year water surface elevation.
  - 5.4.7.19. Emergency overflow shall be explicitly addressed in the design, and the 100-year peak inflow shall be used as a minimum basis for designing pond emergency overflow structures.
  - 5.4.7.20. All drainageways outfalling into a detention/retention pond shall have adequate erosion protection and energy dissipation at the outlets.
  - 5.4.7.21. All pond slopes shall be 4 in 1 or flatter.
  - 5.4.7.22. Inflow facilities to wetland bottom ponds shall have their inverts at least 1 foot above the pond bottom to allow for deposition of sediment.
- 5.4.8. **Outlet/Release Structures.** Outlet/release structures shall be designed as simply as possible and shall require little attention for proper operation.
- 5.4.8.1. Typically, an orifice plate is installed on the outlet structure to regulate released flows from the detention and water quality pond. The water quality orifice(s) should be sized to allow the WQCV to drain over a 40-hour period.
  - 5.4.8.2. Outlet structures inside ponds used for both water quality and detention should be staged through the use of orifices or weirs so that the WQCV drains first, then the minor event, and finally the major event. The orifices and/or weirs should be sized to precisely regulate the release of minor and major storms.

**5.4.8.3.** A trash rack should be placed over each detention pond or water quality outlet structure and should be designed as follows:

- Trash racks must have a net opening area of at least four times the area of the outlet orifice, but in no event less than 3 square feet.
- Trash rack bar spacing shall not exceed 6 inches and shall be no larger than half the diameter of the smallest dimension of the outlet orifice.

#### **5080-6. Drainage System Construction**

- 6.1.** Contractors responsible for such construction or installation shall comply with the licensing and permitting requirements set forth by the BIA and all applicable federal, state, local, and/or tribal laws.
- 6.1.1.** The contractor cannot construct, install, place, or attempt to construct, install, or place any storm drainage system extension or related subsurface structure or facility without first having procured BIA approval.
- 6.1.2.** It shall be the responsibility of the Designer of Record to obtain any permits required for construction, placement, or installation of the proposed drainage facilities under Section 404 of the Clean Water Act. Refer to Section 5040 of this handbook for guidance on preparing a storm water management plan (SWMP).
- 6.1.3.** Unless otherwise agreed to by the BIA, it shall be the responsibility of the Designer of Record to obtain any floodplain map amendments or revisions required as the result of the project construction.

**5090-1. General**

- 1.1. This section provides roadway layout guidelines for BIA Justice / Detention facility projects. Road systems should provide convenient, safe access for automobiles, buses, emergency vehicles, service vehicles, waste collection vehicles, and large trucks delivering supplies to the site.
- 1.2. Site disturbance should be held to a minimum beyond building perimeters, roadways, curbs, walkways, utility trenches, etc., as delineated by the U.S. Green Building Council's LEED-NC rating system.

**5090-2. Street Layout**

- 2.1. Housing and institutional areas shall be separated, but serviced, from the main access road. Wherever possible, curvilinear and looped streets shall be used within the housing areas.
- 2.2. Streets should run parallel with the natural ground contours.
- 2.3. Street layout should eliminate potential traffic control problems and consider large trucks and/or bus activity, emergency vehicles, and fire protection access.
- 2.4. At dead ends, provide turnaround circles at least 100 feet in diameter between curbs.

**5090-3. Horizontal Alignment**

- 3.1. Design speed shall be as shown in Figure 5090-1.

**Figure 5090-1: Alignment Controls**

|                   | Design Speed (mph) | Maximum Grade (Percent) | K Factor |     | VCL Min. Length (Feet) Crest | VCL Min. Length (Feet) Sag | SSD (Feet) | Min. Radius (Feet) |
|-------------------|--------------------|-------------------------|----------|-----|------------------------------|----------------------------|------------|--------------------|
|                   |                    |                         | Crest    | Sag |                              |                            |            |                    |
| Arterials         | 50                 | 6                       | 160      | 75  | 120                          | 80                         | 450        | 955                |
| Low density/rural | 45                 | *6                      | 120      | 65  | 90                           | 70                         | 375        | 745                |
| Collector 4-lane  | 45                 | *5                      | 120      | 65  | 90                           | 70                         | 375        | 745                |
| Collector 2-lane  | 35                 | *5                      | 50       | 50  | 50                           | 50                         | 250        | 425                |
| Local             | 25                 | *5                      | 20       | 30  | 50                           | 50                         | 150        | 150                |
| Private drive     | 15                 | *5                      | 20       | 30  | 50                           | 50                         | 100        | 100                |

\* Eight percent may be allowed by the BIA where an alternate access route, at 6 percent or less, exists. In severe weather climates, flatter grades than those shown should be used.

**3.2. Street Grades**

- 3.2.1. Provide spot elevations to the nearest 0.01 foot at street intersections and at all grade breaks and alignment breaks, and at 50-foot intervals on the back of sidewalk, back of curb, flowline, and centerline to provide a full cross section.
- 3.2.2. Specific project requirements will define whether surfaced streets shall be constructed with or without curb and gutter. Street widths shall be measured from flowline of curb to flowline of curb. Where curb and gutter are not used, street widths shall be from inside of shoulder to inside of shoulder.

**3.3. Horizontal Curves.** The minimum centerline radius for horizontal curves shall be as shown in Figure 5090-1. Variances from these requirements for local streets only will be considered on a case-by-case basis, if justified in writing by the Designer of Record.

**3.4. Intersections**

- 3.4.1. ***Turning Radius.*** All roadways shall intersect at right angles. See Figure 5090-2 for curb return radius requirements.

**Figure 5090-2: Curb Return Flowline Radius at Intersections**

|                               | Local | Collector | Arterial |
|-------------------------------|-------|-----------|----------|
| Driveway<br>21 or more spaces | 35    | 35        | 35       |
| Local or private street       | 35    | 35        | 35       |
| Collector                     | --    | 35        | 35       |
| Low-density rural             | 35    | 35        | 35       |
| Arterials                     | --    | --        | 35       |

**3.5. Superelevation.** Superelevation may be required for arterial roadways and selected collector roadways. Horizontal curve radius and superelevation shall be in accordance with the recommendations of AASHTO.

**3.6. Barricades.** Whenever roadways terminate due to project phasing, subdivision boundaries, etc., barricades are required. A note shall be placed on the plans directing the contractor to construct permanent Type III barricades (as specified in MUTCD) across the roadway terminus.

**5090-4. Vertical Alignment**

- 4.1. Design controls for vertical alignment are shown in Figure 5090-1.
  - 4.1.1. ***Permissible Roadway Grades.*** Designers are encouraged to avoid grades that are less than 0.75 percent to prevent maintenance and icing problems. The minimum allowable grade for any roadway is 0.5 percent. The maximum allowable grade for any roadway is shown in Figure 5090-1.

**4.1.2. Permissible Grades Approaching Intersections**

- 4.1.2.1. The maximum grade at intersections shall be 3 percent for the distances shown in Figure 5090-3.
- 4.1.2.2. At intersecting arterials, the maximum permissible grade shall be 2 percent for 200 feet on either side of the flowline of the intersecting street.
- 4.1.2.3. Private driveway, parking lot drive, and fire lane grades may be 4 percent maximum when sloping toward the public street and up to 6 percent maximum when sloping away.
- 4.1.2.4. The maximum slope for single-family driveways is 12 percent. In all cases where driveways are steeper than 10 percent, there shall be an accompanying pedestrian walk to the main entry with steps as needed to allow a maximum slope of 10 percent on the walk, in areas not requiring ADA access.
- 4.1.2.5. To accommodate ADA access, the maximum cross-slope of a crosswalk shall be 2.0 percent.

**Figure 5090-3: Permissible Intersection Grade**

|                               | Local (Feet) | Collector (Feet) | Arterial (Feet)   |
|-------------------------------|--------------|------------------|-------------------|
| Private driveways and streets | 65           | 65               | 75                |
| Local                         | 95           | 100              | 125               |
| Collector                     | --           | 120              | 200               |
| Low-density rural             | --           | 120              | 200               |
| Arterial                      | --           | --               | 200 (2.0 percent) |

**4.1.3. Grades Changes**

- 4.1.3.1. Continuous grade changes, or “roller-coastering,” shall not be permitted. The use of grade breaks, in lieu of vertical curves, is not encouraged.
- 4.1.3.2. If a grade break is necessary and the algebraic difference in grade does not exceed 0.50 percent every 25 feet, the grade break will be permitted, except at intersections where an algebraic difference in grade of 0.80 percent will be permitted to facilitate the warping of the side street to meet the through street.

**4.1.4. Cross-Slopes**

- 4.1.4.1. Except at intersections or where superelevation is required, new roadways shall be level from top of curb to top of curb with a 2 percent crown as measured from centerline to lip of curb, or lip of



median curb to lip of outside curve on roadways with raised center islands.

- 4.1.4.2. Parabolic or curve crowns are not allowed.
- 4.1.4.3. The cross-slope of a street intersecting a street of higher classification shall be warped to match the grade on the higher-classification street.
- 4.1.4.4. Maximum pavement cross-slope is 4 percent at intersections, as measured above. The rate of change in pavement cross-slope to match the through street shall not exceed 1 percent every 25 feet horizontally on a local roadway, 1 percent every 40 feet horizontally on a collector roadway, or 1 percent every 50 feet horizontally on an arterial roadway.
- 4.1.4.5. Separate flowlines shall be shown until a standard cross section is obtained.

#### 4.1.5. *Vertical Curves*

- 4.1.5.1. All vertical curves shall be symmetrical and shall meet the design criteria in Figure 5090-1. The minimum grade within a sag (sump) vertical curve is 0.50 percent.
- 4.1.5.2. All vertical curves shall be labeled, in the profile, with length of curve (L) and K ( $K = L/A$ , where K = the horizontal distance needed to produce a 1 percent change in gradient, and A = the algebraic difference between the two tangent grades, as a percent), high/low points, point of intersection (PI), point of curve (PC), point of tangency (PT), and stations and elevations.
- 4.1.5.3. Refer to AASHTO's *A Policy on Geometric Design of Highways and Streets*.

#### 4.1.6. *Intersections*

- 4.1.6.1. In addition to the other requirements set forth herein, the following criteria shall apply at intersections: The grade of the "through" street shall take precedence at intersections. At intersections of roadways with the same classification, the more important roadway, as determined by the BIA, shall have this precedence.
- 4.1.6.2. The elevation at the point of curb return (PCR) on the through street is set by the grade of the through street in conjunction with pavement cross-slope. In retrofit situations, pavement cross-slopes between 1 percent and 4 percent may be approved.
- 4.1.6.3. Carrying the crown of the side street into the through street is not permitted.
- 4.1.6.4. At an arterial-arterial intersection, a more detailed drawing of the entire intersection's drivability shall be provided.

- 4.1.6.5. Separate flowline profiles and pavement cross-slopes in the plan view shall be shown until a normal cross section is obtained on each side of the intersection, in addition to standard requirements of a roadway plan.
- 4.1.6.6. Show spot elevations in the intersection, on the plan view, on an approximate 15-foot grid. Show this information on separate plan and profile sheets at minimum scales of 1 inch equals 20 feet horizontally, and 1 inch equals 2 feet vertically.

#### 4.1.7. *Curb Returns*

- 4.1.7.1. Minimum grade around curb returns, when turning water, shall be 1.27 percent. Label high-point elevation and distance from PCR. Label the station and elevation of the upstream flowline intersection when a crossspan is required.
- 4.1.7.2. Maximum fall around a curb return equals the steepest grade (greater than or equal to 2 percent) coming into or out of a return multiplied by the length of the return, plus 0.2 feet.

- 4.1.8. *Connection with Existing Roadways.* Connections with existing roadways shall be smooth transitions. If the algebraic difference in grade (A) exceeds 0.50 percent, a vertical curve shall be used to transition the grade following criteria herein.

### 5090-5. **Specification for Fire Lanes, Private Streets or Drives, and Parking Lots**

- 5.1. **General.** This section provides design requirements in addition to those listed elsewhere in this chapter that specifically address private streets, driveways, parking lots, and fire lanes. For more information, refer to Section 5030.
- 5.2. **Curbs.** Vertical or combination curbs shall border all private streets, unless their omission is approved by the BIA.
- 5.3. **Parking Area and Parking Lots.** Island noses for landscaping, utility access, or pedestrian access may be located within areas of perpendicular parking stalls, but no island may project within 18 feet of the centerline of the street. Curb radii shall be a minimum of 3 feet except in locations allowing drive-through access.
- 5.4. **ADA Ramps.** Wheelchair access shall be provided along designated pedestrian paths from each area of parking to adjacent buildings and connecting sidewalks.
  - 5.4.1. Ramps shall have a minimum width of 48 inches, a maximum slope of 1 vertical in 12 horizontal, approach areas, and turning areas as provided for in the ADAAG and ABA.
- 5.5. **Permissible Grades.** The maximum permissible grade for fire lanes is 7 percent. The maximum permissible grade for single-family residential driveways is 12 percent. Where grades are in excess of 10 percent, there shall be

an accompanying pedestrian walk to the main entry with steps to keep the slope of the walk to a maximum of 10 percent.

**5.6. Parking Spaces.** Minimum parking space sizes are 9 feet in width by 18 feet in length. Provide handicapped-accessible parking in accordance with the ADAAG and ABA.

**5.6.1.** Use of recycled material to assist with LEED credit is an option for wheel stops.

**5090-6. Roadway Specifications**

**6.1.** Following in Figure 5090-4 is a summary of the minimum roadway requirements.

**Figure 5090-4: Roadway Specifications**

| Roadway Type                    | Minimum Roadway Width, Flowline to Flowline (Feet)             | Type of Sidewalk, Curb, and Gutter       |
|---------------------------------|--|--|
| Parking drive aisle             | 24 feet + curb (if applicable)                                 | 6-inch vertical curb and gutter (2 feet) |
| Private drive                   | 26 feet  | 6-inch vertical curb and gutter (2 feet) |
| Local street                    | 26 feet  | 6-inch vertical curb and gutter (2 feet) |
| Four-lane collector             | 52 feet  | 6-inch vertical curb and gutter (2 feet) |
| Two-lane collector              | 42 feet  | 6-inch vertical curb and gutter (2 feet) |
| Low-density rural               | 28 feet  | 4-foot gravel shoulder on each side      |
| Six-lane arterial               | 76 feet (3-lane: 38-foot roadways; 12-foot min. raised median) | 6-inch vertical curb and gutter (2 feet) |
| Four-lane arterial              | 64 feet (2-lane: 32-foot roadways; 14-foot min. center island) | 6-inch vertical curb and gutter (2 feet) |
| Local commercial and industrial | 24 feet  | N/A                                      |
| Fire lane                       | 24 feet  | N/A                                      |

**5090-7. Traffic Control Devices**

**7.1.** All devices such as traffic control, signage, and markings should be designed in accordance with MUTCD.

**7.1.1.** Signs should be explicit in function, providing regulations, warnings, and guidance information for road users, displaying both symbol and word messages.

7.2. Signs should be illuminated or reflective to convey the same information during the day and night, unless specifically stated otherwise.

7.2.1. Figure 5090-5 provides guidance in choosing sign coloring.

**Figure 5090-5: General Sign Color Code Meaning**

| Color                    | Associated Meaning                                |
|--------------------------|---|
| Black                    | Regulation  |
| Blue                     | Evacuation route                                  |
| Brown                    | Recreational and cultural interest area guidance  |
| Fluorescent pink         | Incident management                               |
| Fluorescent yellow-green | Pedestrian, bicycle, playground                   |
| Green                    | Indicated movements permitted, direction guidance |
| Orange                   | Temporary traffic control                         |
| Red                      | Stop or prohibition                               |
| White                    | Regulation  |
| Yellow                   | Warning   |

7.2.2. Markings, including pavement, curb, object markers, delineators, colored pavements, barricades, channelizing devices, and islands are used to supplement other traffic control devices. Consider possible limits to visibility caused by weather and debris when establishing marking frequency.

### 7.3. Signage and Striping

7.3.1. In the overall street system layout and design, include traffic control and safety devices, signage and pavement marking, and striping to guide vehicular and pedestrian traffic.

7.3.1.1. Speed limit, fire lane, and caution signs should be posted consistently throughout the campus.

### 7.4. Bridges

7.4.1. For purposes of these criteria, a bridge is defined as a structure, including requisite supports, erected over a depression or an obstruction (water, highway, or railroad) and having a passageway for carrying traffic or other moving loads.

7.4.2. A bridge is further defined as having a minimum length of more than 20 feet between undercopings of abutments.

7.4.3. Bridge roadway widths shall meet typical widths for standard roadway lane widths.

- 7.4.4.** Where feasible, a culvert or box(es) shall be used in lieu of a span bridge. Where a bridge is recommended by the Designer of Record, a registered professional engineer shall provide design documentation meeting road and bridge standards for the State Department of Transportation.

**5100-1. General**

1.1. This section provides paving design guidelines for road, street, and parking lot areas for BIA Justice / Detention facilities. Soil conditions should be examined by a geotechnical engineer for recommendations related to paving and subgrade preparation prior to the start of paving.

**1.2. Applicable Publications**

1.2.1. Road and paving materials and methods shall be in accordance with the State Department of Transportation construction and materials specifications.

1.2.2. Pavement markings within public rights-of-way shall be in accordance with the *Manual on Uniform Traffic Control Devices (MUTCD)*.

**5100-2. Soil Compaction**

2.1. Based on the documented soil type over which the pavement will lie, minimum compaction requirements should be met. Refer to geotechnical recommendations.

2.2. **Subgrade Conditions.** All soil groups, excluding A-1 through A-4, shall be tested to determine swell or settlement potential as part of the geotechnical evaluation. The swell tests shall be plotted and the percent swell/settlement and swell pressure shall be determined and reported. Test results that are suspected of being too high or too low for the soil type shall not be considered in the design of the pavement, but shall be reported. Any deletion of data shall be justified in the report. The swell/settlement potential for a given soil shall be the calculated average of each of the classification groups.

2.2.1. As a minimum, the report shall specify the required depth of moisture treatment of the subgrade. That depth shall be determined by the highest average percentage of swell, recorded as a whole number as indicated in Figure 5100-1.

**Figure 5100-1: Moisture Treatment Requirements\***

| Swell Potential              | Depth of Moisture Treatment | Depth of Chemical Stabilization Treatment |
|------------------------------|-----------------------------|---|
| < 3 percent swell            | 1 foot                      | ----                                      |
| >3 percent < 5 percent swell | 3 feet or                   | ----                                      |
|                              | 1.5 feet                    | 1 foot                                    |
| > 5 percent swell            | 1.5 feet                    | 1 foot                                    |

\* Indicated average percentage of swell as recorded to the nearest whole number. Moisture treatment shall achieve a moisture content and compaction as specified by the geotechnical engineer.

2.2.2. Soils with a greater than 5 percent swell shall also require swell mitigation in addition to moisture treatment.

2.2.2.1. Stabilizing agents: The preapproved stabilizing agents are listed in Figure 5100-2. Various combinations of these materials may also be used, subject to a suitable mix design by the geotechnical engineer. In the event that stabilized subgrade is used for the purpose of swell mitigation, either lime or a combination of lime and fly ash should be used as a stabilizing agent.

**Figure 5100-2: Preapproved Stabilizing Agents**

| Agents            | Must Conform to the Requirements of: |            |
|-------------------|--------------------------------------|------------|
| Lime              | ASTM                                 | C977, C110 |
| Fly ash (C and F) | ASTM                                 | C618       |
| Cement kiln dust  | ASTM                                 | D5050      |
| Portland cement   | ASTM                                 | C114       |

2.2.2.2. High-calcium quicklime shall conform to the requirements of ASTM C977. Fly ash may consist of Class C or Class F; Class F fly ash shall be allowed only in conjunction with lime or other stabilizing agents.

2.2.2.3. All soil stabilizing methods and materials shall be defined by the geotechnical engineer.

**5100-3. Materials**

- 3.1. Base gravels, asphalt, and asphaltic concrete pavements for streets and parking lots should be consistent with State Department of Transportation standard specifications for the state in which the project is located.
- 3.2. Concrete paving is the preferred paving material. In selecting pavement material, the Designer of Record is to consider geotechnical recommendations, weather, and budget parameters.

**5100-4. Vehicular Considerations**

- 4.1. In designing pavement thickness, consider the street or roadway category (arterial, collector, local) along with vehicle type and maximum weight, and traffic volume (number of trips).

**5100-5. Pavement Systems**

**5.1. Flexible Pavements**

- 5.1.1. Compacted aggregate base shall consist of stone, gravel, or slags with appropriate composition and gradation in accordance with the geotechnical report and the State Department of Transportation.

- 5.1.2. Use locally available materials and gradations that exhibit a satisfactory record of previous installations.

## 5.2. Rigid Pavements

- 5.2.1. Rigid cement concrete pavements above base course include conventional and modified pavements for walks, roads, parking lots, and service areas.

### 5.2.2. *Materials*

- 5.2.2.1. Concrete: ASTM C150, Type II; Portland cement; ASTM C33, normal-weight aggregates; potable water unless the geotechnical engineer designates otherwise.

5.2.2.2. Design mix:

- ASTM C94, 4,000 psi, 28-day minimum compressive strength.
- The water/cement ratio should be 0.45.
- Slump limit at point of placement: 3 inches. Slump limit for concrete containing high-range water reducing admixture (superplasticizer): not more than 8 inches after adding admixture to site-verified 2- to 3-inch slump concrete.
- Air content: 5 to 8 percent; broom finish.

- 5.3. Reinforcing. Reinforcing shall be provided in areas of heavy loading, such as trash pads, bus pads, service drives, fire truck access road areas, etc. Acceptable reinforcing includes the following for concrete paving in areas with standard loading:

- Wire mesh: Welded plain steel wire fabric, ASTM A185.
- Reinforcing bars: Deformed steel bars, ASTM A615, Grade 60.
- Fabricated bar mats: Steel bar or rod mats, ASTM A184, using ASTM A615, Grade 60 steel bars.
- Joint dowel bars: Plain steel bars, ASTM A615, Grade 60. Epoxy coated joint dowel bars, ASTM A775 with ASTM A615, Grade 60 plain steel bars.
- Liquid membrane forming and sealing curing compound: ASTM C309, Type I, Class A.
- Epoxy adhesive: ASTM C881.

- 5.3.1. Acceptable shrinkage control shall be provided, such as fiber mesh or welded wire fabric; proper chairing must be required for welded wire fabric.



**5.3.2.** The required thickness of nonreinforced concrete pavement is 6 inches, minimum, based on a 28-day flexural strength concrete of 650 psi and the established modules of subgrade reaction.

**5.4. Minimum Pavement Sections.** If the geotechnical engineer’s calculated pavement sections indicate thinner sections than the minimum pavement sections listed in Figure 5100-3, the minimums shown in Figure 5100-3 shall govern. The BIA may increase the minimum pavement section at any location if, in their opinion, conditions warrant. If the geotechnical engineer recommends thicker sections, then those recommendations are to be followed. All asphalt roadways will be paved with a minimum of two lifts, regardless of minimal thickness.

**Figure 5100-3: Minimum Pavement Sections\***

| Section Usage Type                            | Full Depth Asphalt | Portland Cement Concrete (PCC) | Asphaltic Concrete (AC) and Aggregate Base |
|---|--------------------|--------------------------------|--|
| Arterials/4-lane collector                    | 7”                 | 7”                             | 5” AC + 9” aggregate base                  |
| 2-lane collector                              | 6.5”               | 6”                             | 4” AC + 8” aggregate base                  |
| Low-density rural/ local street/private drive | 6”                 | 6”                             | 3” AC + 9” aggregate base                  |
| Parking, all other                            | 6”                 | 6”                             | 3” AC + 9” aggregate base                  |
| Parking areas, cars only                      | 5”                 | 6”                             | 3” AC + 8” aggregate base                  |
| Bus/service drives/ fire lanes                | 7”                 | 7”                             | 4” AC + 9” aggregate base                  |

\* For pavement section thicknesses that the geotechnical engineer certifies as being acceptable for the on-site soil characteristics, the BIA, at their discretion, may allow variance to the identified minimum sections.

**5.5. Gravel/Base Course/Local Acceptable Surface Material.** For areas of vehicular travel limited to service vehicles remote from the immediate vicinity of the Justice / Detention and areas used for overflow parking, a readily available gravel/base course or acceptable local material may be used. Adequate structural integrity for potential vehicle and fire truck loading must be provided. Additionally, adequate width and spacing from other structures such as fencing must be provided. A minimum of 5 feet separation is suggested.

**5.6. Pavement Labeling**

**5.6.1. Striping Paint.** Specify white, yellow, and blue fast-drying chlorinated rubber-alkyd type traffic lane marking paint, factory mixed, quick drying and nonbleeding AASHTO M248 (FS TT-P-115), Type III.

**5.6.1.1.** Thermoplastic resins for pavement markings may be an option if specified by the Designer of Record, but they are not needed for

Justice / Detention parking lots. Public roads can use this type of marking, as specified by the local Department of Transportation.

- 5.6.1.2.** All pedestrian crosswalks, parking spaces, and no-parking zones should be striped according to specifications. Striping should be 4 inches wide and white, except handicapped-accessible spaces, which will be blue.
- 5.6.2. *Wheel Stops.*** Used in areas where curb and gutter is not used and vehicles may track on landscape or natural turf areas, wheel stops shall be reinforced precast 3,500 psi air-entrained concrete, approximately 6 inches high, 9 inches wide, and 7 feet long, with chamfered corners and drainage slots on the underside.
- 5.6.3.** Provide two 3/8-inch diameter, 2-foot-long steel rods for anchoring each block to the pavement.

**6000-1. Introduction**

- 1.1. This chapter shall be used as a guideline for landscape architects and landscape designers, as well as other disciplines, in the development and design of the landscape for new BIA Justice /Detention facilities. This shall encompass all outdoor areas associated with landscape, as well as technical aspects of irrigation, soil considerations, mulch treatment, and weed and pest management. The design shall be in conformance with these guidelines unless exceptions to them are granted by the BIA.
- 1.2. Refer to Chapter 1, “General Information,” and Chapter 2, “Presentation of Data,” for required documents, drawing and specifications formats, and other design and submittal requirements not discussed in this chapter.
- 1.3. Additional design and submittal requirements may apply for projects with unusual or highly technical criteria.
- 1.4. As applicable, the Designer of Record shall incorporate the sustainability strategies identified in Chapter 3, “LEED Goals and Guidelines.”
- 1.5. The guidelines in this chapter should be used in conjunction with those in the other chapters in this handbook, particularly Chapter 4, “Site Design.” The Designer of Record should also coordinate with other project consultants to be sure all site features are effective and compatible. Coordination with the architect and the civil engineer are required.
- 1.6. All landscape features must be weighed carefully for their initial cost, long-term maintenance cost and needs, durability, and their impact on the environment.

**6010-1. General**

- 1.1. The site and landscape should be designed for consistency with the overall project scope and functional requirements as defined by the BIA. Use landscape materials to blend architectural elements with the site and surrounding area and to assist in achieving Leadership in Energy and Environmental Design (LEED) certification goals.

**6010-2. Efficiency/Economy**

- 2.1. Select and design materials, systems, and components appropriate to the project requirements.
- 2.2. Recognize and respect the existing site features and preserve and/or enhance them to the greatest extent possible.
- 2.3. Design systems and plantings so as to minimize short- and long-term maintenance.
- 2.4. Select environmentally sensible products and practices.

**6010-3. Safety/Security**

- 3.1. All products specified for the site should be considered for their safety.
  - 3.1.1. Consider landscaping in overall design of security for detention and justice facilities. All shrubs and trees should be placed to ensure that sight lines to the perimeter are not obscured. Positioned landscaping away from perimeter walls and fences to make it more difficult to breach security barriers.
  - 3.1.2. Landscaping may be useful to control circulation or to block access to windows with the use of tough, thorny type planting in strategic locations.
  - 3.1.3. Landscape materials are limited to non-secured outdoor areas of detention facility. Locate away from fencing or wall separating secured and non-secured outdoor spaces.
  - 3.1.4. When choosing any plant species, consider carefully its toxicity to humans. Do not choose highly toxic plants (including but not limited to rosary pea, monkshood, daphne, English ivy, foxglove, lantana, castor bean, potato vine, belladonna, mescalbean, and oleander).
  - 3.1.5. Special care should be taken for the use and storage of cleaning or plant care chemicals.
- 3.2. See Section 6020 for all applicable codes, standards, and laws associated with safe materials for justice and detention facility sites.
- 3.3. Consider the use and location of plant material with respect to general safety and security, including such issues as open or restricted sight lines and limiting access to the site.

**6010-4. Durability**

- 4.1. All products and plant materials chosen for the site should be sufficiently resilient and durable.
- 4.2. Choose products that will be durable in the site's climate.
- 4.3. When choosing a product, consider its ease of repair, restoration, or resistance to vandalism.
- 4.4. Plant material placement, as well as plant selection, is an important durability consideration and is discussed further in Section 6030.

**6010-5. Existing Natural Systems**

- 5.1. When choosing products and plant material, consider the product or plant's adaptability to the following (whether the material is native/local or imported):
  - 5.1.1. **Water and Drainage.** The water source and water availability are the most important components of landscape design. Landscape material, percentage of landscape to hardscape area, nonirrigated landscape, and other design solutions will be determined based on the availability of irrigation water for the site. Existing drainage patterns should also be considered when selecting plant material and landscape products. Along steeply sloped terrain use 6- to 12-inch rock that may be found locally for erosion control; do not plant larger caliber trees along steeply sloped areas.
  - 5.1.2. **Soil Conditions.** These may vary across the site. Existing conditions may require the addition of soil amendments or limit the plant material choices. Soils should be evaluated prior to plant selection for alkalinity, density, and water saturation and absorption properties. Soil tests such as these may be performed as part of the geotechnical testing; however, if any of the above-listed tests are not included in the geotechnical reports, they should be conducted separately.
  - 5.1.3. **Climate Conditions.** Precipitation, wind, sun, and temperatures (as well as temperature fluctuations) should be considered when choosing plant material, paving materials, and site furniture. Exposure to particular climatic conditions may cause certain materials to deteriorate faster than others.

**6020-1. General**

- 1.1. For landscape design, follow all applicable current codes, standards, and laws. For a more general list of codes and standards that apply to BIA Justice/Detention facilities, refer to Chapter 1, "General Information." During design, report any required deviations from codes and standards to the Contracting Officer.
- 1.2. Where two codes, standards, or laws are applicable to the topic under review, use the more conservative or more stringent. Consult with the BIA Office of Facilities Management and Construction (OFMC) to resolve any questions or conflicts regarding application of codes and standards.

**6020-2. Applicable Codes and Standards**

- 2.1. The design criteria shall comply with the guidelines published by or contained in the following:
  - American Joint Committee on Horticultural Nomenclature *Standardized Plant Names*, Second Edition, 1942
  - American National Standards Institute (ANSI), specifically ANSI Z60.1 *American Standard for Nursery Stock*, developed by the American Nursery & Landscape Association (ANLA; formerly the American Association of Nurserymen)
  - *National Best Practices Manual*
  - United States Department of Agriculture (USDA)
    - Rules and regulations under the Federal Seed Act
    - Hardiness zones per USDA publications
  - U.S. Consumer Product Safety Commission (CPSC)

**6020-3. Personnel Qualifications**

- 3.1. Persons qualified to provide landscape design services as described in this document must either:
  - 3.1.1. Hold a degree in landscape architecture or landscape design, or
  - 3.1.2. For each year short of graduation, have at least one year of experience under professional leadership and guidance to substitute satisfactorily for formal education.
- 3.2. The landscape Designer of Record must meet all requirements of registration and/or licensure in the state of the project.
- 3.3. The landscape contractor who will be installing the landscape must be appropriately registered as required by all state and local jurisdictions.

- 3.4. The irrigation designer and/or installer must be appropriately registered as required by all state and local jurisdictions. Work involving substantial plumbing for installation of copper piping, backflow prevention devices, and related work shall be executed by a plumber who is appropriately licensed by state and local jurisdictions.

**6030-1. General**

- 1.1. Landscape should be an integral part of the BIA Justice/Detention facility site. Landscape materials will provide protection from sun and wind, and provide a sensory experience. .
  - 1.1.1. Do not locate landscaping materials inside secured portions of detention facility.
  - 1.1.2. Do not locate trees and shrubs near fencing or walls that separate secured and non-secured areas of detention facility.
- 1.2. Vegetation will also define use areas and circulation routes, provide open-space buffers to adjacent land uses, supplement erosion control, and provide visual continuity between the buildings, the site, and the surrounding environment.

**6030-2. Existing Vegetation**

- 2.1. High-quality specimens of existing vegetation should be considered for preservation whenever possible. Preservation reduces landscaping costs, provides mature landscape from the start of the project, and is an indication of existing site conditions. It is the easiest and most cost-effective way to provide landscape on a site. Existing plant material may include individual specimens or groups of trees, cacti, shrubs, forbs, vines, grasses, or perennials.
- 2.2. Existing plant material that is considered invasive or a weed species by local or state jurisdictions should be removed using the most effective yet environmentally sensitive practices possible.
- 2.3. If existing landscape includes plants with thorns or spines, consider its proximity to activity areas and the hazards it may pose to users of the site.
- 2.4. Existing vegetation that will remain should be protected during construction, using construction fencing and other means to clearly delineate areas of preservation.

**6030-3. Plant Species Selection**

- 3.1. Choose plants for their compatibility with and adaptability to the site's climate, soils, and use, and whenever possible, use vegetation that is drought tolerant and/or native to the justice/detention facility's climate.
- 3.2. Plants should be chosen for their durability and resilience.
- 3.3. Group plant species with similar water requirements together.
- 3.4. No plants with spines or thorns should be placed in active-use areas. Use these plants only to screen or limit access to maintenance or service areas.
- 3.5. Monocultures are not allowed. Plant variety promotes healthy plant communities and visual interest.
- 3.6. Conceptual plant locations, sizes, and types should be included as part of the preliminary landscape design.



- 3.7. A plant palette, including trees, shrubs, cacti, ornamental grasses, forbs, perennials, annuals, vines, and seed mixes should be nearly finalized at the final concept plan, but should be complete, and all plants labeled, for the final construction documents.

**6030-4. Turf Areas**

- 4.1. Consider the amount of anticipated foot traffic and water required when specifying turf areas.
- 4.2. When possible, use a turf blend with the lowest water requirements that will still achieve the desired affect.
- 4.3. If an area is not located in a high-traffic area it is recommended that native or xeric seed mixes or gravel be used to reduce water use and the cost of installation and maintenance.

**6030-5. Seeded Areas**

- 5.1. Seeding is an excellent way to minimize cost and cover larger areas. Seeded areas will need to be monitored closely, specifically within the first year, for weeds.
- 5.2. Seeded areas can be irrigated or nonirrigated, but the seed type should be specified accordingly. All seed should meet United States Department of Agriculture rules and regulations under the Federal Seed Act.
- 5.3. The preferred method for seeding should be specified as drilling. If broadcast seeding is necessary, the chosen seed rate should be doubled, and if hydroseeding is necessary, the chosen seed rate should be multiplied by four. All seeded areas should be covered with a minimum of 1/4 inch of soil and rolled smooth.
- 5.4. Mowing is the best method to prevent the spread of weeds; areas should be mowed before weeds flower or go to seed and should be cut as high as possible while removing the seed or flower head. The frequency of mowing will be determined by whether the area is irrigated or nonirrigated and how rapidly weeds and the grasses are growing.

**6030-6. Bed Areas**

- 6.1. Whenever possible, planting beds should be elevated or located around the edges and in corners of use areas. Do not create islands for bed areas unless they are elevated to a height that will not be walked over.
  - 6.1.1. Beds are restricted to outdoor areas of justice facility and non-secured outdoor areas of detention facility.
- 6.2. Carefully consider all plants' mature height and spread, and specify their placement appropriately.

- 6.3. Bed areas should not be tripping hazards; beds should be easily identifiable and delineated with edging. Edging can vary from rolled-edge metal to stone or masonry edging.
  - 6.3.1. Wood and plastic edging should not be used; they will require higher levels of maintenance and will weather and deteriorate more quickly than other materials.
  - 6.3.2. No metal edging without safe or rolled edges is allowed.
- 6.4. The edges of beds should be designed with smooth lines and not contain kinks or other shapes that are difficult to lay out in the field.
- 6.5. Weed fabric should be specified for all planting beds, except in areas of perennial or annual flowers. Fabric should be cut around plants, not tucked and folded.

#### **6030-7. Foundation Plantings**

- 7.1. Do not place shrubs, ornamental grasses, forbs, perennials, or annuals closer to a building than 5 feet from the center of the plant to the foundation of the building.
- 7.2. Do not place trees closer to a building than 15 feet from the center of the plant to the foundation of the building. Consider the mature spread of a tree, and place it appropriately. Do not place trees along steeply sloped terrain.
- 7.3. Minimize turf and seeded areas directly adjacent to building foundations. If these areas do contain turf or are seeded, provide a minimum 1-foot separation of concrete or rock mulch to allow for mowing and to prevent irrigation water from damaging the foundation and building walls.
- 7.4. Carefully consider the location of evergreen trees and shrubs, specifically in front of windows. Select species so that at maturity they will not be higher than the bottom of the window openings or wider than a wall face between windows.
- 7.5. Also carefully consider all plants' mature height and spread, and specify their placement appropriately.
- 7.6. If raised beds are included adjacent to the building, they should be designed with positive drainage away from the foundation, and waterproofing should be placed adjacent to the building. For these areas, coordinate with the architect and civil engineer.
- 7.7. Changes in the field may need to be coordinated with other Designers of Record to prevent conflicts between plant material and the building windows, utilities, and other design features.

**6040-1. Water Conservation Concepts**

- 1.1. Design landscapes that promote conservation and efficient use of water through plant selection and placement, irrigation product selection, and water management. All of these should be consistent with the specific site conditions. The use of native plant material is encouraged. Adapted plant material is also acceptable.
- 1.2. In areas where the annual natural average precipitation exceeds 30 inches a year, an automatic irrigation system is optional. However, a system for hand watering must be provided.
  - 1.2.1. For hand watering, specify hose spigots or quick-coupling valves. Place the spigots or quick-coupling valves at least 20 feet from building foundations.
- 1.3. In some regions, water conservation concepts may also be referred to as xeriscape (the term xeriscape is derived from the Greek word xeros, meaning dry, combined with landscaping. The xeriscape concept provides seven principles for water conservation:
  - 1.3.1. **Planning and Design.** Site and landscape design should consider the future use of the space, existing sun and water availability, and other external influences such as views.
  - 1.3.2. **Soil Improvements.** The addition of soil amendments to improve the soil's water absorption properties is important for successful plant growth and efficient water use.
  - 1.3.3. **Efficient Irrigation.** Irrigation system methods that promote water conservation may include the appropriate use of the following water-efficient systems and components (also see "Irrigation System Design," below):
    - Drip irrigation systems
    - Pressure regulation systems
    - Low-head drainage controls
    - Reclaimed water systems
    - Rain override devices
  - 1.3.4. **Zoning of Plants.** Consider hydrozones as part of the landscape design. The hydrozone concept is to group species with similar light and water requirements together and within the same irrigation zones.
  - 1.3.5. **Mulches.** Mulching keeps plant roots cool and minimizes water evaporation. Mulches come in two types, organic (such as shredded cedar) and inorganic (such as rock or gravel). Organic mulches will need to be replaced over time, unless the plant material has covered the area and replacement is not needed. Inorganic mulches should not be used on south

or west sides adjacent to building walls, because these mulches tend to retain and radiate heat. However, they are an excellent choice for windy areas.

- 1.3.6. **Turf Alternatives.** Choosing a turf with low water needs may help reduce water consumption while still providing the appearance and benefit of conventional turf.
- 1.3.7. **Appropriate Maintenance.** Regular maintenance, proper irrigation, and weed, pest, and disease management are all important components in a successful landscape.

#### 6040-2. Water Source

- 2.1. The water source and water availability are the most important components of the landscape design. They will determine the amount of water available for all on-site design features.
  - 2.1.1. If using a limited water source, the quantity of irrigation water will be determined based on the remaining available water after the uses and needs of the buildings are finalized.
  - 2.1.2. Often the water for irrigation can be a different system from the one used for the buildings, and is not necessarily required to meet the highest standards of drinking water. This increases the options for irrigation water when potable water is limited.
- 2.2. If it is both cost effective and available, use reclaimed water for irrigation. Reclaimed water can be classified as nonpotable or graywater (conforming to applicable health codes).

#### 6040-3. Irrigation System Design

- 3.1. For irrigation system design, consider soil types and infiltration rates. In order to avoid runoff, do not overspray onto nonirrigated or nonpermeable areas. Design for water application rates less than the infiltration rate of the soil.
- 3.2. The irrigation system design should consider site conditions, water pressure, potential fluctuations in pressure, water source, and other elements affecting the success of the system.
- 3.3. All irrigation equipment shall be institutional or commercial grade.
- 3.4. All products need to be compatible with other irrigation system components, and should function within the manufacturer's safe operating range.
- 3.5. The design of the irrigation system should include the use of drip irrigation for all trees and shrubs placed in nonturf areas.
- 3.6. Drip irrigation or misting spray heads (with adjustable heights) should be used in bed areas.
- 3.7. Spray irrigation should be used in turf areas.

- 3.8. Temporary irrigation methods can be considered for the establishment of native or other seed mixes. If permanent irrigation in seeded areas is desired, those areas can be irrigated using spray heads.
- 3.9. Conform to the requirements of the reference information listed below except where more stringent measures are required by local codes or specified in the contract documents:
  - American Society for Testing and Materials (ASTM) – Specifications and Test Methods
  - Underwriters Laboratories (UL) – UL Wires and Cables

### **3.10. Water Distribution Equipment**

- 3.10.1. For efficiency and effectiveness, the design may incorporate spray, drip, or subsurface water distribution components.
- 3.10.2. Select sprinkler heads, drip irrigation, and subsurface equipment based on durability, ease of maintenance, and manufacturer's performance data, as well as on-site conditions.
- 3.10.3. Specify only sprinkler heads and drip irrigation equipment that has matched precipitation rates within each irrigation zone.
- 3.10.4. Design drip irrigation systems to meet the water requirements of plants from initial planting through maturity.
- 3.10.5. Where reclaimed water is used for irrigation, use the industry standard of equipment with purple markings or components—spray heads, valve boxes, and control valves (purple piping is not required)—to indicate that the water is nonpotable.

### **3.11. Control Systems/Control Valves**

- 3.11.1. Include automatic electric control systems for efficient system operation on all irrigation systems.
- 3.11.2. Include automatic electric control valves to control flow to the various hydrozones.
- 3.11.3. Select the valves for reliable operation and to provide appropriate water quality.
- 3.11.4. Select pressure-regulating valves as needed.
- 3.11.5. Select isolation valves as appropriate to facilitate maintenance and repairs.
- 3.11.6. Use one valve box for each type of valve specified.
- 3.11.7. Use quick-coupling valves at the end of all main irrigation lines and elsewhere as needed to meet supplemental manual watering and maintenance requirements.
- 3.11.8. Specify air relief valves at the high points of all main lines as needed.

**3.12. Filters**

- 3.12.1. Incorporate filters that are recommended by the manufacturer of the primary irrigation system components.
- 3.12.2. Choose filters based on the characteristics of the water source.
- 3.12.3. Size filters based on system flow. Incorporate automatic purging of filters where warranted by water conditions.

**3.13. Backflow Prevention Devices**

- 3.13.1. Design systems to keep the pressure loss through the backflow prevention devices within the manufacturer's optimum operating specifications.
- 3.13.2. Install the devices according to local codes and Uniform Plumbing Code (UPC) guidelines.

**3.14. Weather-Sensing Override Devices**

- 3.14.1. To minimize automatic watering, specify rain-sensing override devices for all irrigation systems.
- 3.14.2. Optional weather-sensing devices include wind and/or freeze sensors. Freeze sensors may be beneficial in climates with common occurrences of early season freezing.

**3.15. Piping****Figure 6040-1: Pipe Sizing**

| Pipe Classifications | Burying Depth     |
|----------------------|-------------------|
| Main lines           | 18 inches minimum |
| Laterals             | 12 inches minimum |
| Drip tubing          | 4 inches minimum  |

- 3.15.1. Piping under paving should be designed and installed with a minimum cover of 18 inches between the top of the pipe and the bottom of the aggregate base under asphalt or concrete paving.
- 3.15.2. Careful consideration should be given to any irrigation piping that may need to be placed under existing pavement areas. The least intrusive and most efficient method shall be used. Any damage to existing pavement shall be repaired.
- 3.15.3. Coordinate pipe bury depths with frost line depth and local installation practices in cold weather climates to ensure proper installation.

**3.16. Pressure and Velocity**

- 3.16.1.** Size water meters to keep anticipated flows within the middle third of the operating range recommended by the system manufacturer so that pressure loss does not exceed 10 percent of the available static pressure.
- 3.16.2.** Do not allow the total system pressure loss to exceed the dynamic pressure minus the recommended operating pressure at the water distribution equipment.

**3.17. Winterization**

- 3.17.1.** Design irrigation system components for positive system drainage.
- 3.17.2.** The system shall be designed to be voided of water using compressed air or a similar method.

**6040-4. As-Built Information**

- 4.1.** In order to provide clear direction for maintenance personnel and the BIA, the following items should be provided at the time the irrigation system construction is completed.
- 4.2.** All as-built conditions should be documented, including:
- The installed configuration of connections to existing water lines
  - Sprinkler line routing
  - Sprinkler control valves
  - Quick-coupling valves
  - Manual drains and stop and waste valves
  - Drip-line blowout stubs
  - Control wire routing if not with the main line
  - Gate valves
  - Control wire and communication cable splices
  - Water meters
  - Flow sensors
  - Locations of all sleeving, including size, quantity, and depth
- 4.3.** Submit a set of three operating instructions, including winterization procedures and start-up procedures, with cut sheets of products and controller/watering operation instruction, to the owner's maintenance personnel.
- 4.4.** Provide one controller chart for each automatic controller installed. The chart may be a reproduction of a record drawing and, if scale permits, fit the controller door. The chart shall reflect the as-built conditions and show the area covered by that controller. All charts shall retain full legibility, even when reduced.

- 4.5. Provide the following items to use for maintenance at the time of construction completion:
- Two sets of special tools required for removing, disassembling, and adjusting each type of sprinkler head and valve installed on the project
  - Two 6-foot valve keys for operation of gate valves
  - Two keys for each automatic controller
  - Two quick-coupler keys and two matching hose swivels for each type of quick-coupling valve installed
  - Two aluminum drain valve keys of sufficient length for operation of drain valves



**6050-1. Soil**

- 1.1. As part of preliminary site analysis, soil testing should be initiated by the Designer of Record to determine the pH level, infiltration rate, salts, and the soil type. Preliminary testing is very beneficial, especially to determine any limitations that the soil type and pH may impose on plant species selections. Some of these tests may need to be repeated prior to installation to reassess disturbed areas. This will be in addition to any geotechnical or other soils testing.
- 1.2. Soils may vary in composition and saturation levels throughout the site; multiple areas should be checked, specifically areas with noticeably different elevations, microclimates, or vegetation.
- 1.3. Strip and save suitable existing soil for reuse in landscaped areas where possible.

**6050-2. Soil Amendments**

- 2.1. The addition of amendments to improve the soil's water absorption properties is important for successful plant growth and efficient water use.
- 2.2. Construction activity will disturb and/or compact soils; prior to landscape installation, an organic soil amendment should be added to disturbed and compacted soil areas.
- 2.3. The type and amount of soil amendment will be determined by soil testing as described above.
- 2.4. All soil amendments shall be evenly distributed and then appropriately tilled into the soil to provide an even mixture between existing soil and amendment material.

**6050-3. Mulch**

- 3.1. The use of mulches in planting beds and around newly planted trees will help keep plant roots cool and minimize water evaporation. Two types of mulch are acceptable, organic (such as shredded cedar) or inorganic (such as rock or gravel).
  - 3.1.1. Organic mulches will need to be replaced over time, unless the plant material has covered the area and replacement is not needed.
  - 3.1.2. The use of inorganic mulch should be minimized on south or west sides adjacent to building walls, because these mulches tend to retain and radiate heat. However, they are an excellent choice for windy areas.
- 3.2. Fine grade all planting beds to be mulched, allowing for a full depth of mulch.
- 3.3. Mulch in beds adjacent to walks and paved areas should not protrude above the paved surface.

**6060-1. General**

- 1.1. Integrated pest management (IPM) is a practice that encourages the use of biological and cultural pest control and the minimized use of chemicals, herbicides, and pesticides to achieve acceptable pest levels with the smallest impact on human health, safety, and flora and fauna within the environment. IPM is the preferred method of weed, disease, and pest management for BIA justice/detention facility landscapes.

**6060-2. Design Concepts**

- 2.1. Select plant species for their adaptability to the site and the local climate.
- 2.2. Create and install an integrated and functional site design that minimizes the need for chemical applications.
- 2.3. Provide appropriate quantities of moisture through the correct design and installation of the irrigation system.
- 2.4. Use fencing and mesh during installation, as appropriate, to help control damage to young plants by deer, rodents, waterfowl, and other animals. As plants mature, these measures can be reevaluated on a case-by-case basis.

**6060-3. Installation and Maintenance Considerations**

- 3.1. Plants and seeded areas should be properly installed to minimize plant stress and help ensure that plant materials are successfully established.
- 3.2. Following through with good maintenance practices and appropriate fertilization applications will promote healthy plant material.
- 3.3. Not all weeds and pests will be eradicated using IPM, but reducing chemical applications will benefit the plants and humans on-site in the long run. Consequently, an acceptable level of pests and weeds on the site will need to be determined as part of reducing the need for chemicals. An integrated weed, disease, and pest management plan and maintenance plan should be developed between the BIA and on-site maintenance staff.
- 3.4. Weeding should be done frequently by hand or by mowing, so that weeds do not go to seed.
- 3.5. Mechanical and biological measures should be used first, with the careful addition of less-toxic sprays and a final consideration of the least-toxic chemicals.

**7000-1. Introduction**

- 1.1. This chapter shall be used as a guideline in the design of all new BIA justice centers and detention facilities. These procedures and systems will help the Designer of Record create attractive, durable, cost-effective buildings that will be economical to maintain. Building design should be based upon recognized and sound commercial building practices. The design shall be in conformance with these guidelines unless exceptions to them are granted by the BIA.
- 1.2. Refer to Chapter 1, “General Information,” and Chapter 2, “Presentation of Data,” for required documents, drawing and specifications formats, and other design and submittal requirements not discussed in this chapter.
- 1.3. Additional design and submittal requirements may apply for projects with unusual or highly technical criteria.
- 1.4. As applicable, the Designer of Record shall incorporate the sustainability strategies identified in Chapter 3, “LEED Goals and Guidelines.”
- 1.5. The guidelines in this chapter should be used in conjunction with those in the other chapters in this handbook, and the Designer of Record should coordinate with the other project consultants to be sure all aspects of justice centers and detention facilities are effective and compatible.
- 1.6. All design features must be weighed carefully for their initial cost, long-term maintenance cost and needs, durability, and their impact on the environment.

**7000-2. Content**

- 2.1. To aid in the design process, a detailed collection of requirements and acceptable building systems has been compiled and is presented in the following sections. These standardized systems are not meant to unduly limit the design. Rather they are intended to help reduce costs and ensure a consistent level of quality for all BIA Justice/Detention facilities, nationwide.

**7000-3. Design Considerations**

- 3.1. The Designer of Record shall ensure that building massing, forms, and layouts offer efficiency of initial and operating costs. Modular dimensions and standard sizes shall be used to the greatest extent possible.
- 3.2. Facility design shall consider building expansion. The Designer of Record shall coordinate the extent of this effort with the BIA.
- 3.3. Below-grade tunnels and crawl spaces are prohibited.
- 3.4. Combustible construction is prohibited without prior written approval of the BIA. All wood used, such as for blocking or substrates, shall be fire treated.
- 3.5. Where humidity levels remain at 60 percent or higher or walls are exposed to direct moisture for extended periods of time, provide water resistant products, including gypsum board at walls and ceilings. If such areas are concealed or have limited air movement, provide materials resistant to microbial growth.

- 3.6.** The Designer of Record shall develop the architectural design to minimize energy usage. Building systems and components must be coordinated from the project inception to produce an energy-efficient design. The envelope design must be incorporated into the energy model discussed in Chapter 10, “Mechanical.”

**7000-4. Compliance Requirements**

- 4.1.** It is recognized that not all design professionals will agree with the choice of the systems shown in this chapter. However, the systems included have been identified through comprehensive performance evaluations and meet the goals of the BIA for their justice/detention facilities. Consequently, the Designer of Record is required to use the specified building systems unless permission to do otherwise is stated in the following sections.

**7010-1. Role of the Designer of Record in Systems Selection**

- 1.1. While these guidelines present a selection of pre-approved systems, it is ultimately the responsibility of the Designer of Record to determine which of the systems is most appropriate for any given project. The Designer of Record must analyze the various considerations included within the individual systems sections to make final recommendations to the BIA. It is not the role of the Designer of Record to analyze components outside of the pre-approved systems unless specifically allowed elsewhere in this chapter to do so.
- 1.2. The Designer of Record is to make all efforts reasonable to avoid custom fabrications. Standard sizes and installation techniques are to be used whenever possible.

**7010-2. Considerations**

- 2.1. This chapter provides the Designer of Record with a menu of approved systems that meet the BIA performance standards. In most cases, the Designer of Record will have more than one option.
- 2.2. These guidelines recognize that many variables exist, depending on market conditions, regional considerations, and design concepts. Considerations for the designer to analyze include, but are not limited to:
  - First costs
  - Life Cycle costs
  - Expected system life
  - Maintenance
  - Durability
  - Local availability
  - Local expertise
  - Local tribal customs and heritage
  - LEED compliance
  - Energy and resource conservation
  - Climate
  - Schedule
  - Acoustics
  - Aesthetics
  - Fire ratings
  - Safety and Security

**7020-1. General**

- 1.1. For architectural design, follow all applicable current codes, standards, and laws. For a more general list of codes and standards that apply to BIA Justice / Detention facilities, refer to Chapter 1, “General Information.” During design, report any required deviations from codes and standards to the Contracting Officer.

**7020-2. Applicable Codes and Standards**

- 2.1. The design criteria shall also comply with the guidelines published by or contained in the following:
  - American Society for Testing and Materials ASTM E 90: *Methods for Measuring Sound Transmission Loss*.
  - American Society for Testing and Materials ASTM E 413: *Determination of Sound Transmission Class*.
  - Americans with Disabilities Act (ADA) *Accessibility Guidelines for Buildings and Facilities (ADAAG)*.
  - California Trial Court Facility Standards: *Design and Security requirements* as applicable for site and justice center design.
  - U.S. Department Of Justice National Institute Of Corrections: *Jail Design, A Resource for Small and Medium-Sized Jails* as applicable for Tier 1 detention facility (48 hour holding) design.

**7030-1. General**

- 1.1. Indicate fixed furniture and equipment if it is included in the design scope of work.

**7030-2. Furniture, Furnishings, and Equipment (FF&E)**

- 2.1. Furniture and equipment provided under FF&E Contract is not included in this Design Handbook. Examples of FF&E equipment provided under a separate contract include:

- Movable furniture and systems furniture including partitions.
- Movable cabinets.
- Appliances (except commercial kitchen equipment).
- Vending machines.
- Window coverings.
- Artwork.
- Small equipment not part of building systems.
- Fitness room equipment.
- Data and communications equipment.
- Cable television equipment.
- Audio/Visual equipment.
- Recording equipment
- Metal detection equipment.
- Detention furniture and furnishings that are connected to the building are to be included in the construction contract. This includes beds and benches located in holding areas and cells.

**7030-3. Representation on Floor Plans**

- 3.1. Identify or schedule size and description. Identify who is responsible for furnishing and installing item.
- 3.2. For new construction, provide location of fixed equipment on plans. Show graphically whether the equipment item is CFI, OFI, or OFCI. Show CFI equipment with solid lines, and OFI /OFCI equipment with dashed lines. Provide and install all built-in utilities or services necessary for the proper use of Contractor-furnished or Owner-furnished equipment.
- 3.3. Where fixed seating, built-in seating, tables, or work surfaces are provided in accessible spaces, make at least one of the seating spaces, tables, or work surfaces (and not less than 5 percent of the total) handicapped compliant.

**7030-4. Detention Furniture and Furnishings**

- 4.1.** Beds: Extra heavy gauge, steel fabricated bunks intended for use in cells and sleeping areas in correctional environments. Fully welded with baked on, factory applied polyester powder coat finish. Wall mounted type welded or bolted to steel plates embedded in CMU wall. Floor mounted type with legs bolted to floor where approved by BIA.
- 4.2.** Benches: Extra heavy gauge benches with cuff rings intended for use in cells and sleeping areas in correctional environments. Fully welded with baked on, factory applied polyester powder coat finish. Wall mounted type welded or bolted to steel plates embedded in CMU wall. Floor mounted type with legs bolted to floor where approved by BIA.



**7040-1. General**

- 1.1. In justice/detention facilities, proper room acoustics are essential to ensure proper room acoustics and sound isolation. Justice and detention facility designs must meet the criteria outlined in this section.
- 1.2. Refer to Space Templates for STC ratings.

**7040-2. Acoustical Design Approach**

- 2.1. Acoustical design for BIA Justice/Detention facilities should follow a structured approach at each stage of the planning and design process. The following is an outline of the process for acoustical design.

**2.1.1. Conceptual/Schematic Design**

- Selection of the site.
- Noise survey to establish external noise levels if applicable.
- Orientation of buildings in relation to noise sources.
- Massing and form of the buildings.
- Consideration of the need for external noise barriers, using buildings, fences and screens, and landscape features.
- Preliminary calculation of sound insulation provided by the building envelope, including the effect of ventilation openings.

**2.1.2. Design Development/Construction Documents**

- Determine appropriate noise levels and reverberation times for the various activities and room types.
- Consider the special needs of the courtrooms, interview rooms, and dayrooms for officer's role in hearing and recording detainees communications.
- Consider the special needs of the detention living areas.
- Architectural/acoustic zoning: Plan the disposition of "quiet" and "noisy" spaces, separating them wherever possible by distance, external areas, or neutral "buffer" spaces such as storerooms or corridors.
- Consider sound isolation separately from other aspects of room acoustics, using walls, floors, and partitions to provide adequate sound isolation.
- Consider the volume and shape of rooms and the acoustic properties of their surfaces when designing room acoustics.
- Specify the acoustic performance of doors, windows, and ventilation openings.
- Specify any sound reinforcement systems.

**7040-3. Acoustical Certification**

- 3.1. The Designer of Record shall submit a letter to the BIA certifying that the design meets the acoustical performance requirements outlined in this section.

**7040-4. Room Acoustics Criteria**

- 4.1. In Figure 7040-1, below, design goals for reverberation times ( $T_{60}$ ) are provided for each space. To meet the criteria (and approach the goal), the Designer of Record shall select finish materials to provide the required space-averaged noise reduction coefficients (NRCs) shown in Figure 7040-1. The NRC values of some common construction materials are given in Figure 7040-2 and should be used for calculations unless another value can be supported by laboratory test data of the selected material. The NRC values for ceiling tile and other materials that are not listed should be acquired from the product manufacturer (and based on laboratory tests).

**Figure 7040-1: Room Acoustics Criteria**

| <b>Room Description</b> | <b>Minimum Space Averaged NRC</b> | <b>Design Goal <math>T_{60}</math> (seconds)</b> |
|-------------------------|-----------------------------------|--|
| Lobby                   | 0.22                              | 1.5  |
| Conference room         | 0.22                              | 0.5  |
| Private office          | 0.16                              | 0.5  |
| Computer lab            | 0.20                              | 0.6  |
| Library                 | 0.23                              | 1.0  |
| Court room              | 0.22                              | 0.6  |
| Jury deliberation       | 0.22                              | 0.6  |
| Judicial chambers       | 0.22                              | 0.6  |
| Interview room          | 0.22                              | 0.5  |
| Dayroom                 | 0.22                              | 0.5  |
| Dining room             | 0.18                              | 1.4  |
| Fitness room            | 0.18                              | 0.8  |
| Activity room           | 0.23                              | 0.5  |

**Note:** To provide proper acoustical characteristics for this room, the acoustical design goals should be established on a case-by-case basis by qualified personnel or acoustical consultants. The room features, including its shape, volume, and diffusive and absorptive treatments, should be selected to achieve the established design goals.

**Figure 7040-2: NRC Values of Some Common Materials**

| Material   | NRC |
|--|-----|
| Brick, unglazed and unpainted                                      | .05 |
| Brick, unglazed, painted   | .00 |
| Carpet, 1/4-inch pile height                                       | .25 |
| Carpet, 1/8-inch pile height                                       | .15 |
| Carpet, 3/16-inch combined pile and foam                           | .25 |
| Classroom marker or chalk board, wall mounted                      | .05 |
| CMU, coarse, unpainted and unsealed                                | .35 |
| CMU, painted or sealed   | .05 |
| Concrete, sealed or painted  | .00 |
| Door   | .05 |
| Floor, vinyl composite tile  | .05 |
| Floor, wood  | .10 |
| Gypsum board, painted  | .05 |
| Metal roof deck, acoustical deck (perforated with insulation fill) | .35 |
| Metal roof deck, exposed   | .05 |
| Window   | .10 |

**7040-5. Sound Isolation Criteria**

- 5.1.** Most rooms in a justice/detention facility can be grouped into the following categories:

Type A: Library; study rooms.

Type B: Conference rooms; computer lab; interview room; dayroom.

Type C: Fitness room; holding cells

Type D: Restrooms; courtrooms; jury deliberation; judicial chambers.

Type E: Corridors.

Type F: Mechanical and electrical rooms.

The airborne sound insulation requirements between each type of space are given in the matrix shown in Figure 7040-3 (with the exceptions shown in the numbered notes). The requirements are listed as sound transmission class (STC) values. The selected walls or floor-ceiling assemblies should meet these requirements, based on their laboratory STC ratings or ratings estimated by qualified professionals.

To ensure compliance, the partitions may be field tested per ASTM E336 Standard Test Method for Measurement of Airborne Sound Insulation in Buildings. Sound insulation test results will be reported as a field sound

transmission class (FSTC) value in accordance with ASTM E413 Classification for Rating Sound Insulation. The measured FSTC should be no more than five points below the required STC rating (according to Figure 7040-3). For example, a wall separating two courtrooms should have a laboratory STC rating of 55.

**Figure 7040-3: Sound Transmission Class (STC) Ratings Between Spaces**

|        | Type A | Type B | Type C | Type D       | Type E       | Type F |
|--------|--------|--------|--------|--------------|--------------|--------|
| Type A | 40     | 45     | 45     | 55           | 40           | Note 4 |
| Type B |        | 40     | 45     | 55           | 40           | Note 4 |
| Type C |        |        | 55     | 55<br>Note 1 | 45           | Note 4 |
| Type D |        |        |        | 55<br>Note 2 | 45<br>Note 3 | Note 4 |
| Type E |        |        |        |              |              | Note 4 |
| Type F |        |        |        |              |              | Note 4 |

**Notes:** Wherever practical, the following guidelines should be followed:

1. Sound isolation between courtroom and holding cell should be STC-65 or greater.
2. Sound isolation between restrooms should be STC-40 or greater.
3. Sound isolation between a restroom and a corridor should be STC-40 or greater.
4. Separation of Type F rooms from other occupied spaces should be analyzed on a case-by-case basis. Where practical, Type F rooms should be separated from occupied space with a buffer space (i.e., storage rooms or other unoccupied space). In any case, the partition(s) separating the Type F room from the occupied room should be designed to reduce the intrusive noise into the occupied room to 5 decibels below the required mechanical noise criterion (NC) level at each octave-band frequency.

## 5.2. General Sound-Isolation Requirements

- 5.2.1. Sound-isolating gypsum board partitions should be installed and sealed per ASTM E497 Standard Practice for Installing Sound-Isolating Lightweight Partitions and ASTM C919 Standard Practice for Use of Sealants in Acoustical Applications.
- 5.2.2. Doors in sound-isolating walls shall be solid-core wood or insulated metal doors. Where the wall must be rated for STC-40, the doors should be equipped with a perimeter smoke seal. Where the wall is rated for STC-45, the doors should be equipped with a perimeter smoke seal, an automatic door bottom, and threshold (if the floor is carpeted). For walls rated STC-55 or higher, the doors shall be an acoustically rated door assembly having an STC rating no less than five points below the wall rating.
- 5.2.3. Floor-ceiling assemblies over conference rooms, offices, courtrooms, jury deliberation rooms, and judicial chambers should provide impact

noise isolation equal to or greater than an impact insulation class (IIC) of 50.

#### 7040-6. Mechanical System Noise Criteria

- 6.1. The mechanical system design shall include means and methods to reduce the mechanical noise levels in occupied spaces to the levels shown in Figure 7040-4. The criteria are given as noise criterion (NC) ratings. These ratings must be maintained at any location within the room that may be occupied by a person as part of the normal use of the room.

**Figure 7040-4: Mechanical Noise Criteria**

| <b>Room Description</b> | <b>Maximum NC Rating</b> |
|-------------------------|--------------------------|
| Lobby                   | 40                       |
| Conference room         | 35                       |
| Private office          | 35                       |
| Computer lab            | 35                       |
| Library                 | 40                       |
| Court room              | 30                       |
| Jury deliberation       | 35                       |
| Judicial chambers       | 35                       |
| Interview room          | 35                       |
| Dayroom                 | 35                       |
| Fitness room            | 40                       |
| Activity room           | 35                       |

**Notes:**

1. NC-35 is the maximum allowable noise level. A noise level of NC-30 is preferred.
2. This noise level may be exceeded when a dedicated exhaust fan is on.

**7050-1. General**

- 1.1. The exterior wall systems in this section have been analyzed with a combination of specific evaluation criteria and identified as building systems that will meet the minimum performance criteria for BIA Justice/Detention facilities. These approved wall systems from which the Designer of Record may choose vary between justice and detention facility building types.

**7050-2. Exterior Wall Selection Criteria**

- 2.1. When making selections for exterior wall systems, the Designer of Record must consider the criteria discussed in Section 7010.

**7050-3. Finishes**

- 3.1. Finishes for exterior wall surfaces must be selected to minimize routine maintenance. Provide integrally colored cementitious materials such as concrete, stucco, and concrete masonry units (CMUs). Provide factory finish for manufactured products such as metal panel assemblies.

**7050-4. Sectional Diagrams**

- 4.1. The cross-sectional diagrams presented in this section are included as diagrammatic images only. Proper placement of air/moisture retarder and thermal performance of insulation must be determined by the Designer of Record based on local climatic conditions.
- 4.2. Sizes and structural properties of masonry units and metal framing must be determined by the Designer of Record to comply with project requirements. Materials may be limited by local/regional availability.
- 4.3. Coordinate thermal performance with Chapter 3. Metal stud wall assemblies will require continuous exterior insulation to minimize thermal conduction through metal framing.

**7050-5. Design Flexibility**

- 5.1. While a limited number of exterior wall systems that meet minimum performance requirements have been preselected by the BIA, it is intended that there be sufficient variation between those systems to allow for some design freedom and flexibility. Design concepts as well as local and cultural considerations will greatly affect the systems selection process.

**7050-6. Justice Center Structures**

**6.1.** Justice center structures include Law Enforcement, Criminal Investigation, Patrol, Administration, Tribal Courts, and Staff Support. These areas include administrative, kitchen, cafeteria, fitness, and courtroom spaces. The approved systems listed below provide a thorough representation of durable, low-maintenance, high-performance exterior walls for justice center. Following this list are descriptions and cross sections of each of the approved exterior wall systems for justice center structures.

**6.2. Approved Exterior Wall Systems for Justice Center Structures**

Provide any of the following material except walls exposed to interior of Interview Rooms and Safety Cells are limited to CMU:

- CMU wall with masonry veneer
- Metal stud wall with masonry veneer
- Insulated concrete panels
- Metal stud wall with metal panel system
- CMU wall with stucco finish system
- Metal stud wall with stucco finish system

**Figure 7050-6(1):  
CMU Wall with Masonry Veneer**

This is a cavity wall system consisting of a CMU wall and brick masonry veneer.

The insulation in this system is placed within the cavity, allowing the inner CMU mass to aid in regulating changes in temperature. An air/moisture retarder is provided to prevent moisture and air migration. Determine location of air/moisture retarder according to local climatic conditions.

Provide interior furring over CMU to a sufficient depth to conceal electrical and IT system components (devices, conduit, raceways, etc.).

With prior approval of the BIA, the interior furring may be eliminated in part or in all locations.

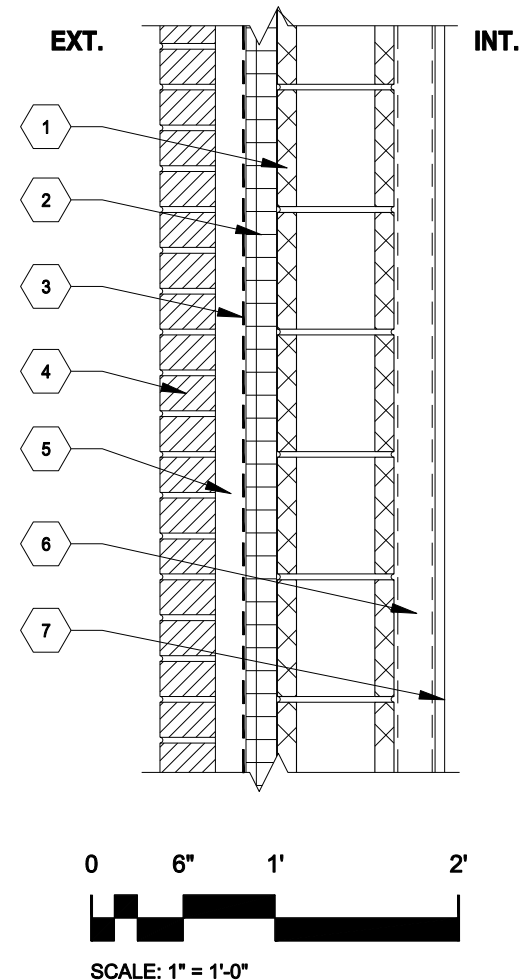
**KEYNOTES:**

1. CMU wall
2. Rigid insulation
3. Air/moisture retarder
4. Masonry veneer
5. Air space
6. Metal stud furring
7. Gypsum board

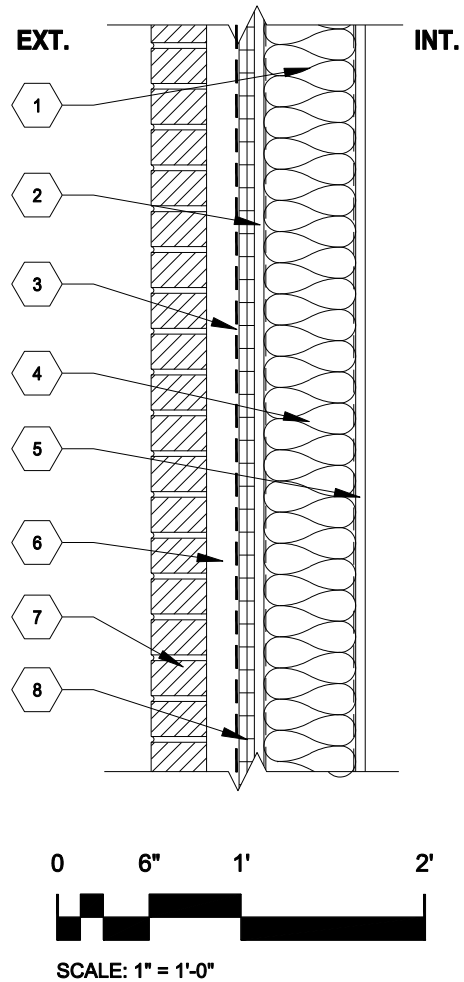

**Figure 7050-6(2):  
Metal Stud Wall with Masonry  
Veneer**

This is a cavity wall system consisting of masonry veneer over stud infill or structural metal studs.

Locate air/moisture retarder to minimize moisture and air migration according to local climatic conditions.

Provide exterior wall sheathing over rigid insulation for continuous insulation. If required for thermal performance, install batt insulation between metal studs.



**KEYNOTES:**

1. Metal stud wall
2. Exterior sheathing
3. Air/moisture retarder
4. Batt insulation
5. Gypsum board
6. Air space
7. Masonry veneer
8. Rigid insulation

**Figure 7050-6(3):  
Insulated Concrete Panels**

This wall system is a tilt-up or precast concrete insulated panel. A layer of rigid insulation and ties are sandwiched between a structural concrete panel and a veneer face panel.

Locate air/moisture retarder to minimize moisture and air migration according to local climatic conditions.

Panel sizes and thicknesses will vary depending on structural loading and workable size. The interior face of the panel shall be furred to a depth sufficient to conceal electrical and IT system components (devices, conduit, cable raceway, etc.).

With prior approval of the BIA, the interior furring may be eliminated in part or in all locations.

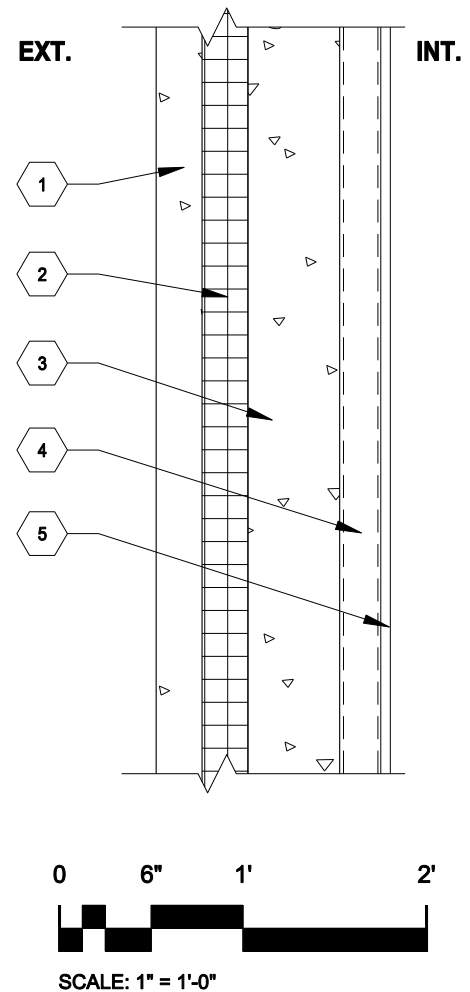
**KEYNOTES:**

1. Concrete face panel
2. Rigid insulation and tie system
3. Structural concrete panel
4. Metal stud furring
5. Gypsum board

**Figure 7050-6(4):  
Metal Stud Wall with Metal Panel  
System**

This system is an insulated metal panel system installed over exterior sheathing and metal stud infill framing or structural stud framing.

Insulated metal panels provide continuous insulation over metal stud framing. Determine location of air/moisture retarder according to local climatic conditions. Provide batt insulation between metal stud framing.

The type of metal panel shall be determined by the Designer of Record according to budget, aesthetic concerns, and constructability. Provide factory finish for all metal panel systems. Locate panels 10 feet minimum distance above adjacent exterior grade.

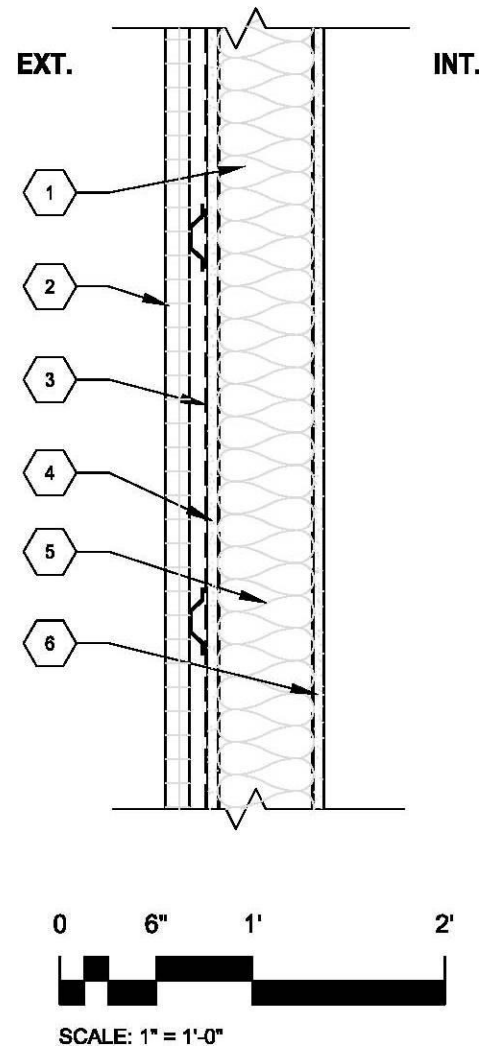

**KEYNOTES:**

1. Metal stud wall
2. Insulated metal panel system
3. Air/moisture retarder
4. Exterior sheathing
5. Batt insulation
6. Gypsum board

**Figure 7050-6(5):  
CMU Wall with Stucco Finish System**

This wall system is a 3-coat stucco system applied over single-wythe CMU wall. The exterior rigid insulation allows the mass of the CMU to aid in regulating temperature changes.

Provide integrally colored or cement coated stucco. The use of acrylic finishes on the stucco is prohibited. Determine location of air/moisture retarder according to local climatic conditions.

Fur interior face of the CMU to a depth sufficient to conceal electrical and IT system components (devices, conduit, cable raceway, etc.). With prior approval of the BIA, the interior furring may be eliminated in part or in all locations.

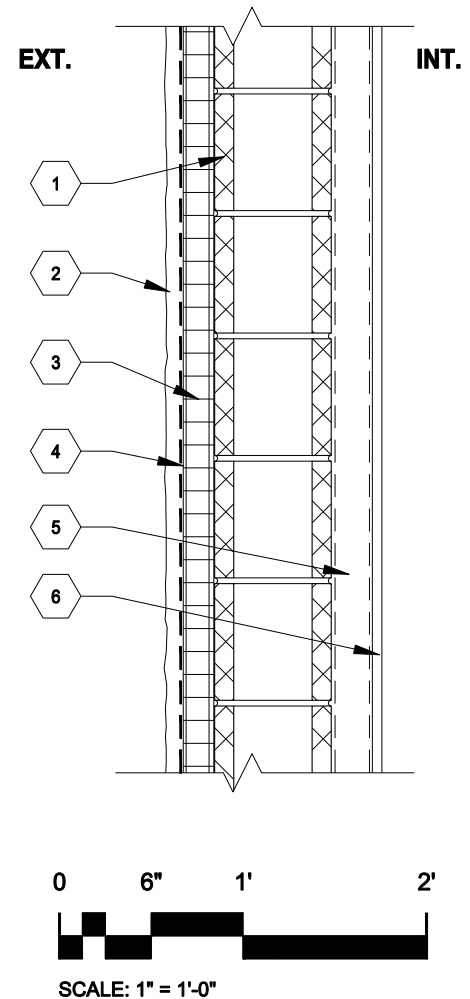
**KEYNOTES:**

1. CMU wall
2. 3-coat stucco system
3. Rigid insulation
4. Air/moisture retarder
5. Metal stud furring
6. Gypsum board

**Figure 7050-6(6):  
Metal Stud Wall with Stucco Finish  
System**

This wall system is a 3-coat stucco system applied over exterior composite sheathing/rigid insulation over metal stud infill framing or structural metal stud framing.

Determine location of air/moisture retarder and thermal properties of batt insulation on local climatic conditions.

Apply stucco system over stucco lath on two layers of weather resistive barrier. Provide integrally colored or cement coated stucco. The use of acrylic finishes on the stucco is prohibited.

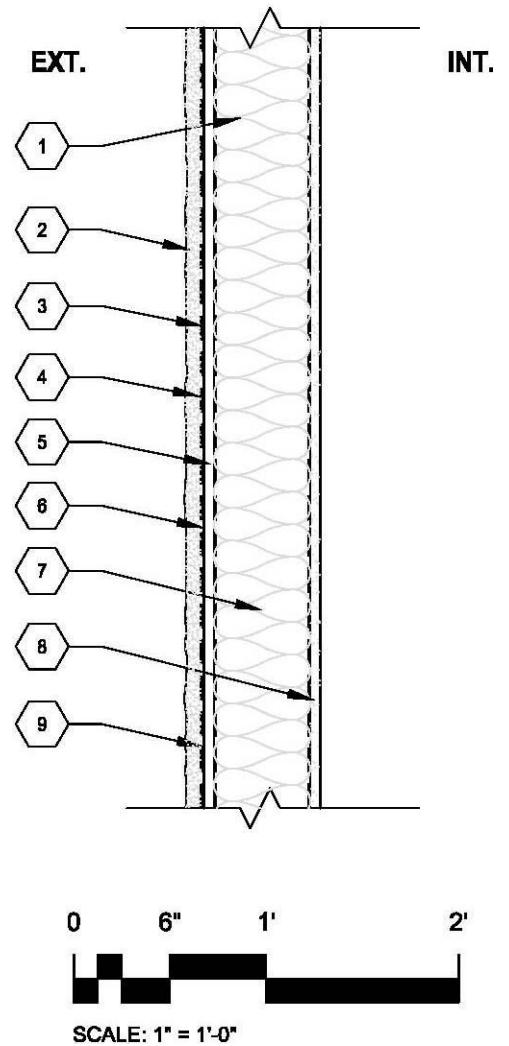

**KEYNOTES:**

1. Metal stud wall
2. 3-coat stucco system
3. Metal lath
4. 2 layer weather resistive barrier
5. Exterior sheathing
6. Rigid insulation
7. Batt insulation
8. Gypsum board
9. Air/moisture retarder

**7050-7. Detention Facility Structures**

- 7.1. Detention Facility is used for short term holding of adults and juveniles. The approved systems listed below are systems that provide a durable interior and exterior wall system. Following this list are descriptions and cross sections of each of the approved systems for detention facility structures.
- 7.2. Security Wall Reinforcing: Provide fully grouted reinforced CMU at all walls with reinforcing steel anchored to walls to floor and roof structure. Maintain continuity of building enclosures to separate all secured interior spaces from unsecured spaces.
- 7.3. Provide high-build paint finishes in wall surfaces in holding cells to provide smooth, non-absorptive surface that durable, easy to clean, and resistant to regular cleanings.

**7.4. Approved Exterior Wall Systems for Detention Facility Structures**

- CMU wall with masonry veneer
- Insulated concrete panels
- CMU wall with insulated metal panel system
- CMU wall with stucco finish system

**Figure 7050-7(1):  
CMU Wall with Masonry Veneer**

This is a cavity wall system consisting of a CMU wall and brick masonry veneer. The insulation in this system is placed within the cavity, allowing the inner CMU mass to aid in regulating changes in temperature.

An air/moisture retarder is provided to prevent moisture and air migration. Determine location of air/moisture retarder according to local climatic conditions.

The interior surface of the CMU is exposed for durability. Conceal electrical and IT system components (devices, conduit, raceways, etc.) in CMU wall. Surface mounting of these items is not permitted without BIA approval due to potential for damage and vandalism.

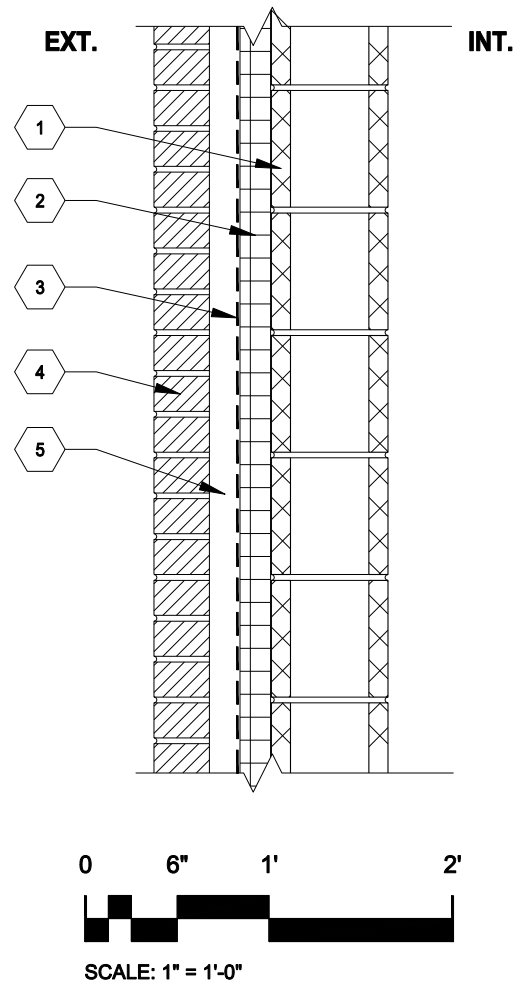

**KEYNOTES:**

1. CMU wall
2. Rigid insulation
3. Air/moisture retarder
4. Masonry veneer
5. Air space

**Figure 7050-7(2):  
Insulated Concrete Panels**

This wall system is a tilt-up or precast concrete insulated panel. A layer of rigid insulation and ties are sandwiched between a structural concrete panel and a veneer face panel.

Locate air/moisture retarder to minimize moisture and air migration according to local climatic conditions.

Panel sizes and thicknesses will vary depending on structural loading and workable size. The interior surface of the concrete panel is exposed for durability.

Cast or block out raceway in concrete panels for electrical and IT system components (devices, conduit, raceways, etc.) if locations at exterior walls cannot be avoided. Surface mounting of these items is not permitted without BIA approval due to potential for damage and vandalism.

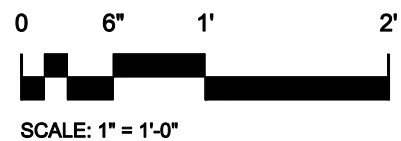
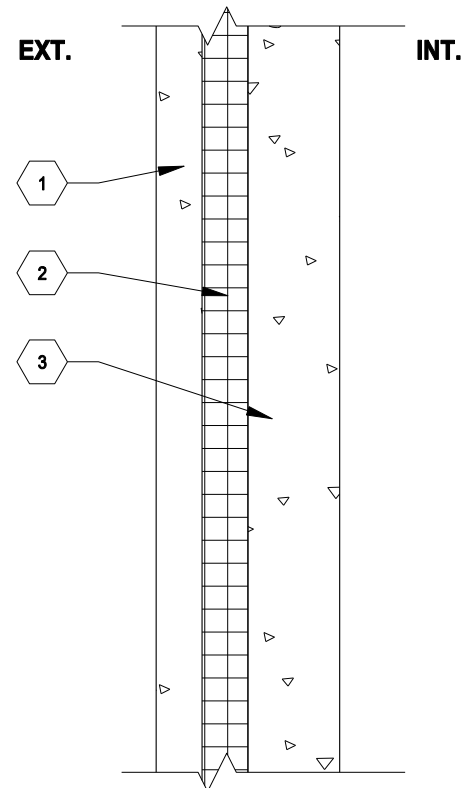

**KEYNOTES:**

1. Concrete face panel
2. Rigid insulation and tie system
3. Structural concrete panel



**Figure 7050-7(3):  
CMU Wall with Insulated Metal Panel  
System**

This system is an insulated metal panel system installed over single-wythe CMU wall. Insulated metal panels help wall achieve thermal performance.

An air/moisture retarder is installed to minimize moisture and air migration. Determine location of air/moisture retarder according to local climatic conditions.

The type of metal panel shall be determined by the Designer of Record according to budget, aesthetic concerns, and constructability. Provide factory finish for all metal panel systems. Locate panels 10 feet minimum distance above adjacent exterior grade.

The interior surface of the CMU is exposed for durability. Conceal electrical and IT system components (devices, conduit, raceways, etc.) in CMU wall. Surface mounting of these items is not permitted without BIA approval due to potential for damage and vandalism.

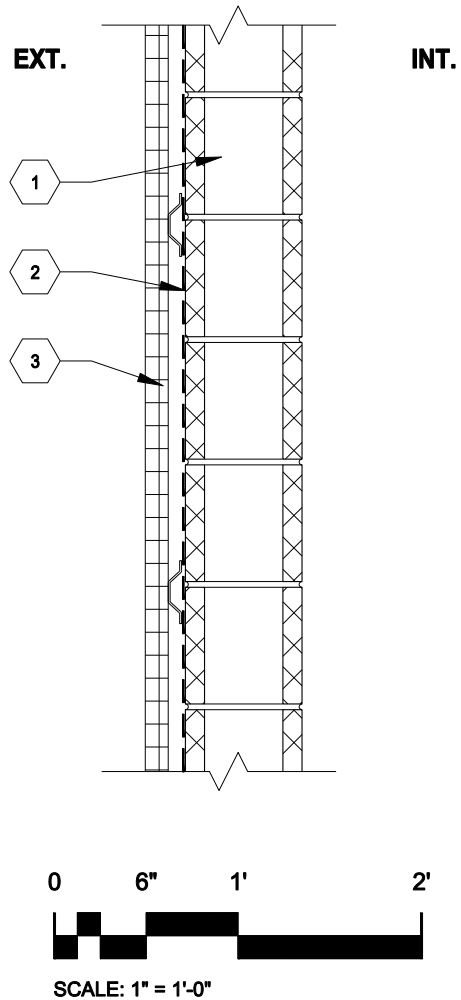

**KEYNOTES:**

1. CMU wall
2. Air/moisture retarder
3. Insulated metal panel system

**Figure 7050-7(4):  
CMU Wall with Stucco Finish System**

This wall system is a 3-coat stucco system applied over single-wythe CMU wall. The exterior rigid insulation allows the mass of the CMU to aid in regulating temperature changes.

An air/moisture retarder is installed to minimize moisture and air migration. Determine location of air/moisture retarder according to local climatic conditions.

Provide integrally colored or cement coated stucco. The use of acrylic finishes on the stucco is prohibited.

The interior surface of the CMU is exposed for durability. Conceal electrical and IT system components (devices, conduit, raceways, etc.) in CMU wall. Surface mounting of these items is not permitted without BIA approval due to potential for damage and vandalism.

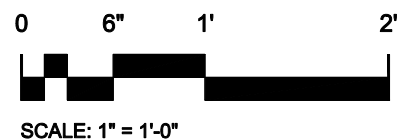
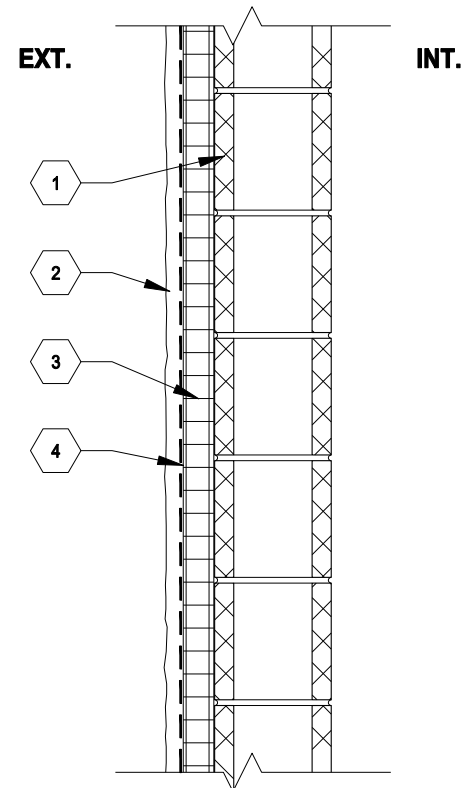

**KEYNOTES:**

1. CMU wall
2. 3-coat stucco system
3. Rigid insulation
4. Air/moisture retarder

**7060-1. General**

- 1.1. Roof configurations and systems for BIA justice/detention facilities will vary in response to building size, design aesthetic and local conditions. To offer the Designer of Record an appropriate selection of preselected options, roofing systems have been analyzed with a combination of specific evaluation criteria and identified as those that will meet the minimum performance criteria for BIA justice / detention facilities.
- 1.2. For the purpose of analysis, roof systems are divided into two main categories: low-slope and steep-slope roofs. Low-slope roofs are roof systems that range from a minimum slope of 1/4 inch per foot to roofs that have 3 in 12 pitch (a 3-inch rise in a 12-inch run). Steep-slope roofs are any roofs with a pitch greater than 3 in 12.

**7060-2. Roof Systems Selection Criteria**

- 2.1. When making selections for roofing systems, the Designer of Record must consider the criteria discussed in Section 7010.

**7060-3. Sectional Diagrams**

- 3.1. The cross-sectional diagrams presented in this section are included as diagrammatic images only. Proper placement of vapor retarders, thicknesses of insulation, roof substrates, and flashing details must be determined by the Designer of Record based on project-specific requirements.

**7060-4. Design Flexibility**

- 4.1. While a limited number of roofing systems that meet minimum performance requirements have been preselected by the BIA, it is intended that there be sufficient variations between those systems to allow some design freedom and flexibility. Design concepts as well as local and cultural considerations will greatly affect the systems selection process.

**7060-5. Low-Slope Roof Systems**

- 5.1. Low-slope roofs approved by the BIA for justice/detention facilities consist of membrane roofs and shall meet the following conditions:
  - 5.1.1. The slope for low-slope roofs must be a minimum of 1/4 inch per foot.
  - 5.1.2. For energy performance, all low-slope roofs must be cool roofs.
  - 5.1.3. Cover boards are to be provided above the insulation for all low-slope roofs.
  - 5.1.4. All membrane roofs are to be fully adhered and should ideally slope toward the perimeter of the building.
  - 5.1.5. Where interior drains are used, consideration shall be given to eliminating potential water ponding, debris collection at the drain, etc.

5.2. The approved systems listed below are for low-slope roofing conditions. Following this list are descriptions and cross sections of each approved system for low-slope roofing conditions.

5.2.1. *Approved Systems for Low-Slope Roofs*

- Thermoplastic polyolefin (TPO) membrane roof – fully adhered
- Ketone ethylene ester (KEE) membrane roof – fully adhered

**Figure 7060-5(1):  
Thermoplastic Polyolefin (TPO) –  
Fully Adhered**

This system is a single-ply, fully adhered TPO membrane roof. TPO membranes are economical membranes that can be obtained in light colors to keep roofs cool.

Welding of seams for TPO roofs requires more skill than do other single-ply membranes. TPO membranes have a high coefficient of expansion, so flashing details must be carefully designed and constructed. Fully adhered systems perform better in high winds than mechanically fastened or ballasted systems.

Installation in cold climates can be problematic, because some adhesion can be lost when the temperature falls below recommended levels. Walkway pads to mechanical penthouses and equipment must be provided.

Minimum warranty period – 10 years

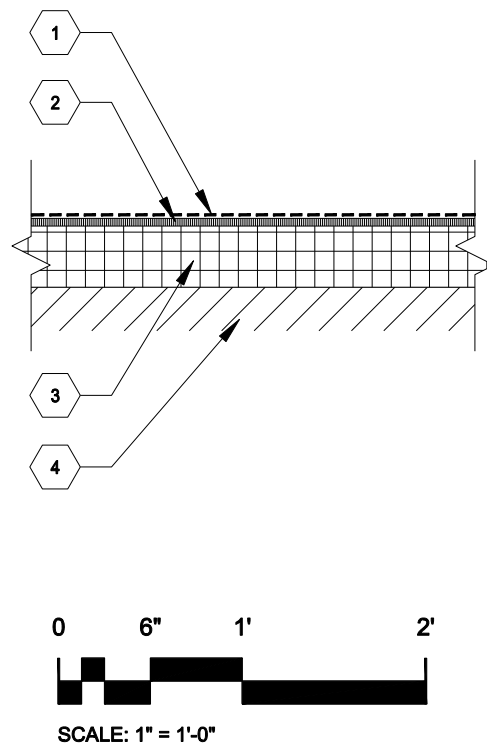

**KEYNOTES:**

1. Fully adhered TPO membrane
2. Cover board
3. Rigid insulation
4. Roofing substrate

**Figure 7060-5(2):  
Ketone Ethylene Ester (KEE) – Fully Adhered**

This system is a single-ply fully adhered KEE membrane roof. KEE membranes are available in light colors to keep roofs cool. Seams of KEE roofs are welded and repair is simple, requiring little special knowledge or skill.

KEE roofing membranes are not as susceptible to chemical and solvent deterioration as other single-ply roofing membranes. KEE performs well in high winds because it has a durable woven layer that prevents the membrane from tearing easily.

Fully adhered systems perform better in high winds than mechanically fastened and ballasted systems. Installation in cold climates can be problematic, because some adhesion can be lost when the temperature falls below recommended levels.

Walkway pads to mechanical penthouses and equipment must be provided.

Minimum warranty period – 10 years

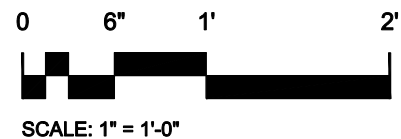
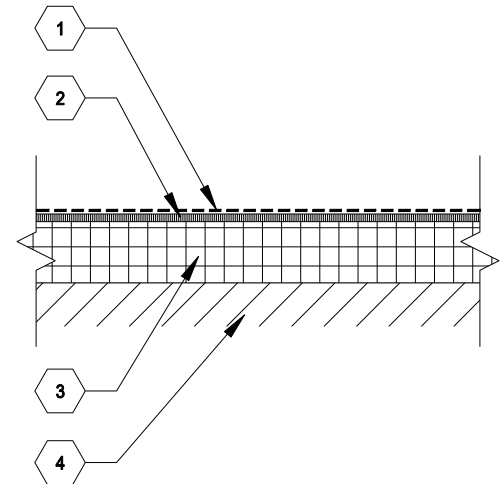

**KEYNOTES:**

1. Fully adhered KEE membrane
2. Cover board
3. Rigid insulation
4. Roofing substrate

**7060-6. Steep-Slope Roof Systems**

**6.1.** Steep-slope roofs approved by the BIA for justice/detention facilities consist of shingle and metal roofs and shall meet the following conditions:

- Slopes shall be a minimum of 3 units vertical in 12 units horizontal.
- Ice and water shield shall be installed on steep-slope roofs in cold climates.

**6.2.** The approved systems listed below shall be utilized for steep-slope roofing conditions. Following this list are descriptions and cross sections of each approved system for steep-slope roofing conditions.

**6.2.1. Approved Systems for Steep-Slope Roofs**

- Asphalt shingles
- Concrete roof tiles
- Metal roofing system

**Figure 7060-6(1):  
Asphalt Shingles**

This roofing system is a steep-slope system of asphalt shingles. Asphalt shingles are available in a variety of colors, profiles, and quality levels, allowing flexibility of design and expense.

Typical asphalt shingle systems are quick to install and economical solutions for steep-slope roofs. A roofing underlayment must be installed under the shingles, and an ice and water shield is required for locations that are exposed to cold and snow.

Asphalt shingles are durable and have a long life expectancy. They are easily maintained and do not require a great deal of special knowledge to repair.

Minimum warranty period – 25 years

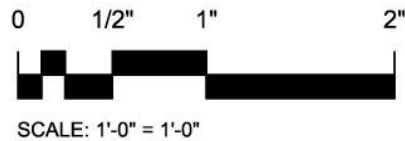
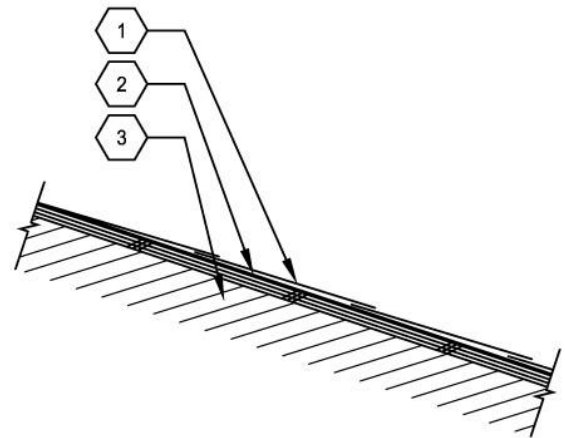

**KEYNOTES:**

1. Asphalt shingles
2. Roofing underlayment
3. Roofing substrate

**Figure 7060-6(2):  
Concrete Roof Tiles**

This roofing system is a steep-slope system of concrete roofing tiles.

Concrete roofing tiles are available in a variety of colors and profiles, allowing flexibility of design.

Concrete roof tiles can be used to mimic stone and clay roofing tiles and thus convey a greater sense of permanence than is possible with asphalt shingles. Concrete tiles are more expensive than asphalt tiles but are highly durable.

Concrete tiles require wood substrates for nailing. A roofing underlayment must be installed under the tiles, and an ice and water shield is recommended for locations that are exposed to cold and snow.

Concrete tiles are easily maintained and do not require a great deal of special knowledge to repair.

Minimum warranty period – 25 years

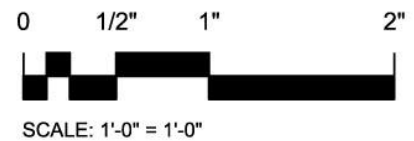
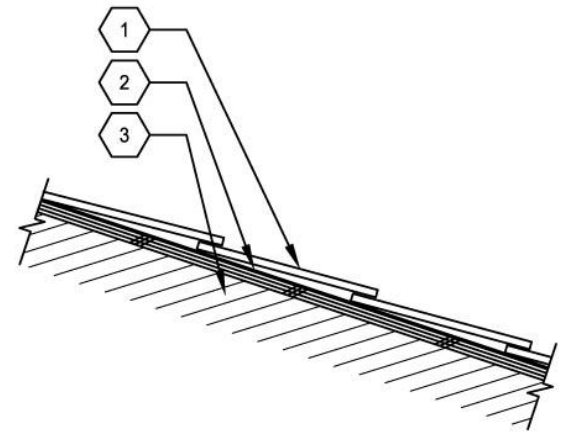

**KEYNOTES:**

1. Concrete roofing tiles
2. Roofing underlayment
3. Roofing substrate

**Figure 7060-6(3):  
Metal Roofing System**

This is a metal roofing system. There are many different varieties of metal roofing systems, and it is up to the Designer of Record to determine which one is the most appropriate for a specific project.

Metal roofing systems must be provided with a high-performance factory finish. A roofing underlayment must be installed under all metal roofing systems.

Metal roofs are durable and have long life expectancies.

Minimum warranty period – 20 years

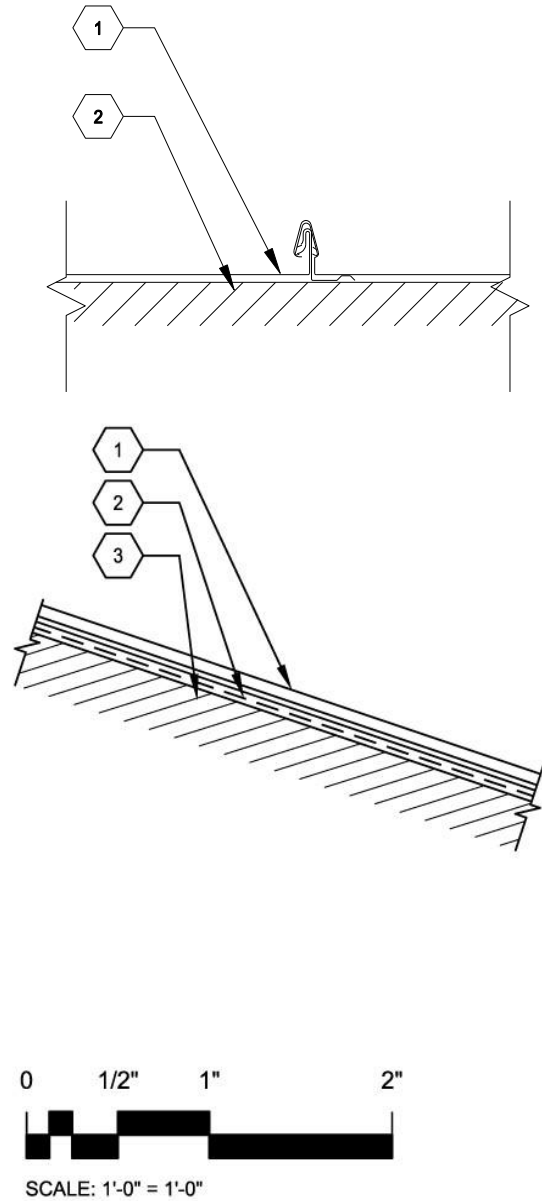

- KEYNOTES:**
- 1. Metal roofing system
  - 2. Roofing underlayment
  - 3. Roofing substrate



**7060-7. Roof Flashing**

7.1. Roof flashings and associated components are vital to the success of the roofing system and must be carefully detailed and specified by the Designer of Record.

**7.2. Standards**

7.2.1. Use the *Architectural Sheet Metal Manual* produced by the Sheet Metal and Air Conditioning Contractors' National Association (SMACNA) as the standard for all roof flashing.

7.2.2. In order to qualify for roofing warranties, it is often necessary to follow manufacturers' published flashing and roofing details. The Designer of Record shall note any conflicts between typical manufacturer's details and those illustrated in the SMACNA standards and make recommendations to the BIA.

**7.3. Finishes**

7.3.1. Flashings for roofs shall be constructed of one of the following materials:

- Galvanized steel
- Copper
- Stainless steel
- Prefinished aluminum/steel

7.3.2. Galvanized steel flashings are not allowed when exposed to public view.

**7.4. Repair**

7.4.1. Flashings shall be detailed such that replacement and repair of roofs require minimum disruption to the building envelope. For example, the use of two-piece flashings and removable cap flashings makes roof replacement much easier.

**7070-1. General**

- 1.1. The approved interior partition systems from which the Designer of Record may choose for BIA Justice/Detention facilities vary according to different building types. This collection of preapproved partition systems for these building types have been carefully chosen to assure that they meet minimum performance requirements while still allowing a measure of design freedom.

**7070-2. Interior Partition Selection Criteria**

- 2.1. When making selections for interior wall systems, the Designer of Record must consider the criteria discussed in Section 7010.
- 2.2. Screen lavatory facilities in detention holding cells for privacy.

**7070-3. Finishes**

- 3.1. Interior finishes shall be highly durable, attractive, and easily maintained. Finishes for interior spaces are detailed in the space criteria sheets included in the *BIA Justice/Detention Facilities Space Templates* and in Chapter 8, "Interiors."

**7070-4. Sectional Diagrams**

- 4.1. The cross-sectional diagrams presented in this section are included as diagrammatic images only. Fire and acoustical rating information is not shown in the diagrams; it is the responsibility of the Designer of Record to meet the levels required for specific projects.

**7070-5. Design Flexibility**

- 5.1. While a limited number of interior partition systems that meet minimum performance requirements have been preselected by the BIA, it is intended that there be sufficient variation between the systems to allow the designer to be creative and meet project budgets. Design concepts as well as local and cultural considerations will greatly affect the systems selection process.

**7070-6. Justice Facility Structures**

- 6.1.** Interior partitions within justice structures include the walls of non-circulation spaces, such as administrative areas; and walls of circulation spaces such as corridors, hallways, and entry areas. In general, noncirculation spaces are the spaces used by personnel when engaged in daily work. Circulation space walls must withstand a higher level of abuse than non-circulation space walls.
- 6.2.** Security Wall Reinforcing: Provide reinforcing steel to anchor walls to floor and roof structure. Maintain continuity of building enclosures to separate all secured interior spaces from unsecured spaces.
- 6.3.** The approved interior partition systems listed below are grouped according to the use of each space. Following this list are descriptions and cross sections of each of the approved systems for justice facility structures:
  - 6.3.1. *Approved Interior Partition Systems for Non-circulation Administrative Areas***
    - Metal stud framing with standard gypsum board
  - 6.3.2. *Approved Interior Partition Systems for Non-circulation in Public Spaces***
    - Metal stud framing with abuse-resistant gypsum board
    - Concrete masonry unit (CMU) partition (Required in Interview Rooms and Safety Cells.)
  - 6.3.3. *Approved Interior Partition Systems for Circulation Spaces***
    - Concrete masonry unit (CMU) partition
    - Metal stud framing with standard gypsum board and masonry veneer to 7 feet 4 inches
    - Metal stud framing with abuse-resistant gypsum board

**Figure 7070-6(1):  
Metal Stud Framing with Standard  
Gypsum Board**

This interior partition system consists of metal stud framing with standard gypsum board on both sides. This is an economical system that provides good performance in areas not subject to high traffic and abuse.

Modification flexibility is good with this system, as it allows electrical, data, etc., to be installed within the stud wall. To obtain acoustical and fire ratings it may be necessary to add layers of gypsum board, acoustical batt insulation, or resilient channels, or to increase stud size, among other modifications.

The Designer of Record must determine any appropriate modifications needed to meet the acoustical and fire-resistance requirements of these guidelines and the applicable codes.

The Designer of Record must also consider building movement to avoid cracking or damage to partitions. Stud sizes and spacing will likely vary depending upon spans, acoustical requirements, and fire ratings.

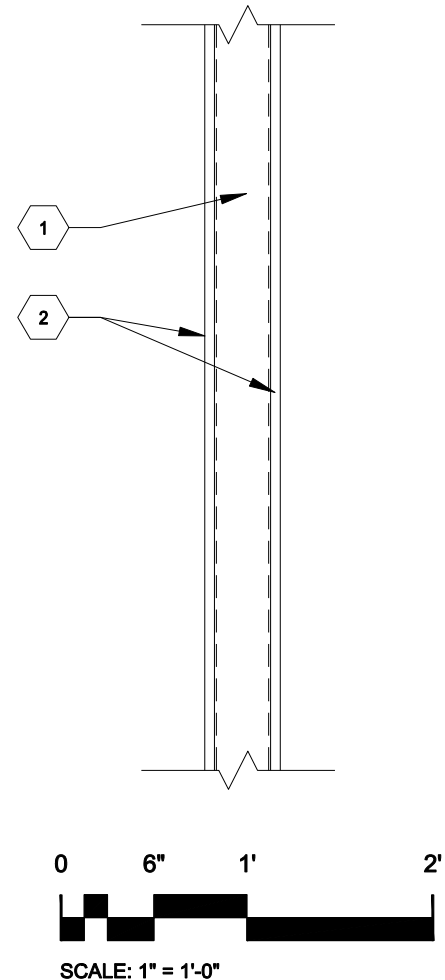

**KEYNOTES:**

1. Metal stud framing
2. Gypsum board

**Figure 7070-8(2):  
Metal Stud Framing with Abuse-  
Resistant Gypsum Board**

This interior partition system consists of metal stud framing with abuse-resistant gypsum board. This is an economical system that provides a more durable performance than standard gypsum board partitions.

Abuse-resistant gypsum board has greater resistance to penetration and surface damage, and offers a higher security rating. Modification flexibility is good with this system, as it allows electrical, data, etc., to be installed within the stud wall.

As with standard gypsum board partitions, these partitions must meet the acoustical and fire-resistance requirements of these guidelines and the applicable codes.

The Designer of Record must also consider building movement to avoid cracking or damage to partitions. Stud sizes and spacing will likely vary depending upon spans, acoustical requirements, and fire ratings.

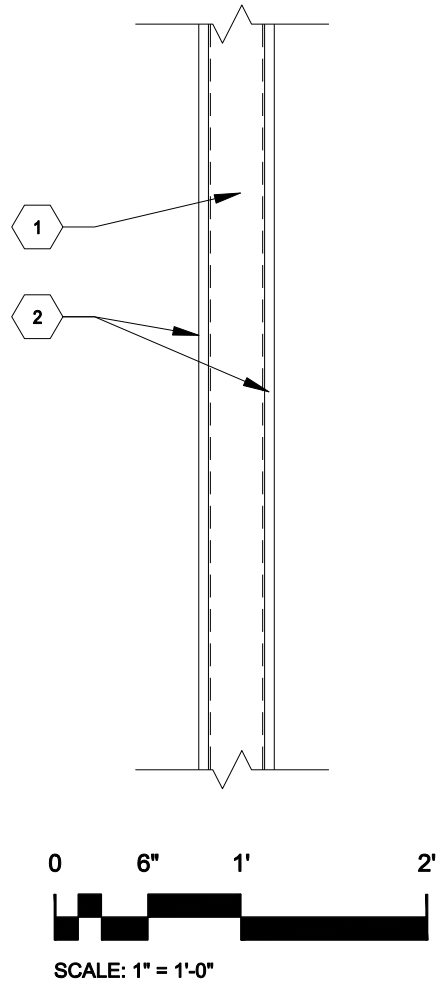

**KEYNOTES:**

- 1. Metal stud framing
- 2. Abuse-resistant gypsum board

**Figure 7070-6(3):  
CMU Partition**

This interior partition system consists of a single-wythe CMU wall. This partition provides a high level of durability and requires little maintenance. Grout solid hollow metal door and window frames installed in masonry walls.

Integral colored and ground face CMU provides a good finish and alleviates the need for maintenance of painted or coated surfaces, although durable paint finishes are also acceptable.

Electrical, IT, and plumbing systems shall be recessed into the partitions. Surface mounting of these items is not permitted without BIA approval due to potential for damage and vandalism.

In some instances, furring of one or both sides of CMU partitions may be considered. This is especially true when the CMU is serving as part of the structural system and the typical partitions are made of metal studs and gypsum board.

As with gypsum board partitions, CMU partitions must meet the acoustical and fire-resistance requirements of these guidelines and the applicable codes.

The Designer of Record must also consider building movement to avoid cracking or damage to partitions. CMU sizes and reinforcing will likely vary depending upon building loads and fire ratings.

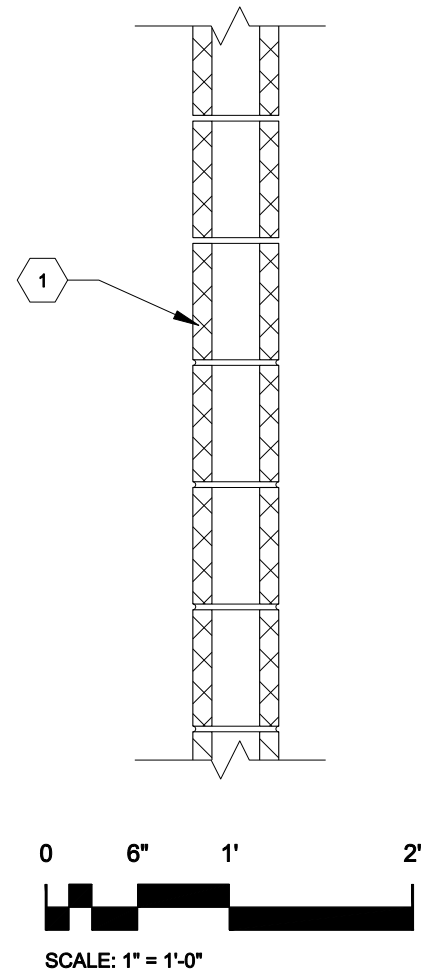

**KEYNOTES:**

1. CMU partition

**Figure 7070-6(4)**  
**Metal Stud Framing with Standard Gypsum Board and Masonry Veneer**

This interior partition system consists of metal stud framing with standard gypsum board and masonry veneer. This combination provides a highly durable masonry base at locations where abuse is more common.

Masonry can be either clay units or CMUs. Integrally colored CMUs are preferred, although highly durable paint finishes are also acceptable. Flexibility for modification is fairly good with this system, as it allows electrical, data, etc., to be installed within the stud wall.

Modification is more difficult to do so at masonry veneer. Surface mounting of electrical, plumbing, and IT system components (devices, conduit, cable raceway, etc.) is not allowed unless prior approval from the BIA is obtained.

As with gypsum board and CMU partitions, the Designer of Record must determine any appropriate modifications needed to meet the acoustical and fire-resistance requirements of these guidelines and the applicable codes.

The Designer of Record must also consider building movement to avoid cracking or damage to partitions. Masonry sizes should conform to industry standard sizes and minimal width requirements to maximize use of the building space. Stud size and spacing will likely vary depending upon building loads and fire ratings.

The height of the masonry is based on typical masonry door frame height with 4 inch head. The masonry height may vary if approved by the BIA.

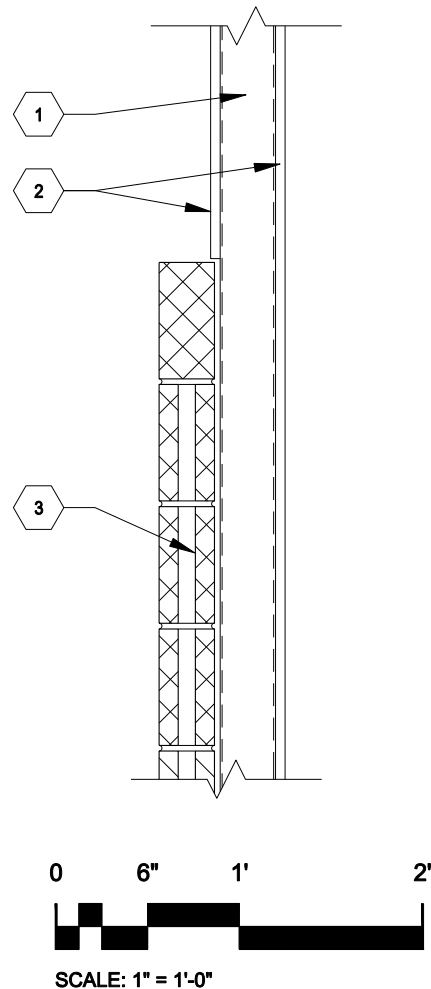

**KEYNOTES:**

1. Metal stud framing
2. Gypsum board
3. Masonry veneer 7 feet 4inch high

**7070-7. Detention Facility Structures**

- 7.1. Interior partitions within detention structures must withstand a higher level of abuse. Following this list are descriptions and cross sections of each of the approved systems for detention structures.
- 7.2. Security Wall Reinforcing: Provide fully grouted reinforced CMU at all walls with reinforcing steel anchored to walls to floor and roof structure. Maintain continuity of building enclosures to separate all secured interior spaces from unsecured spaces.
- 7.3. Provide high-build paint finishes in wall surfaces in holding cells to provide smooth, non-absorptive surface that durable, easy to clean, and resistant to regular cleanings.

**7.3.1. *Approved Interior Partition Systems***

- Concrete masonry unit (CMU) partition



**Figure 7070-6(3):  
CMU Partition**

This interior partition system consists of a single-wythe CMU wall. Wall is fully grouted with steel reinforcing. Grout solid hollow metal door and window frames installed in masonry walls.

This partition provides a high level of durability and requires little maintenance. Integral colored and ground face CMU provides a good finish and alleviates the need for maintenance of painted or coated surfaces.

Electrical, IT, and plumbing systems shall be recessed into the partitions. Surface mounting of these items is not permitted without BIA approval due to potential damage and vandalism.

In some instances, furring of one or both sides of CMU partitions may be considered. This is especially true when the CMU is serving as part of the structural system and the typical partitions are made of metal studs and gypsum board.

As with gypsum board partitions, CMU partitions must meet the acoustical and fire-resistance requirements of these guidelines and the applicable codes.

The Designer of Record must also consider building movement to avoid cracking or damage to partitions. CMU sizes and reinforcing will likely vary depending upon building loads and fire ratings.

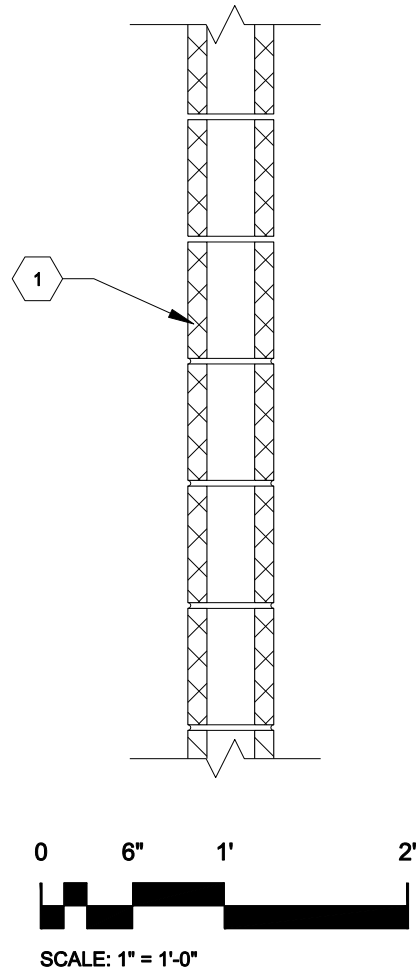

- KEYNOTES:**
1. Fully grouted CMU partition with steel reinforcing

**7080-1. General**

- 1.1. This section provides roof drainage guidelines for new BIA justice/detention facilities. Roof drainage is critical in designing low-maintenance buildings and shall be closely coordinated with the civil design to ensure proper drainage away from the building structure. Water cannot drain or pond on sidewalks where freezing occurs.

**7080-2. Low-Slope Roof Drainage**

- 2.1. Roofs shall be designed to provide positive drainage for all parts of the roof area. As discussed in Section 7060, the minimum acceptable roof slope is 1/4 inch per foot.
- 2.2. In designing low-slope roofs, the Designer of Record shall locate roof drains toward the perimeter of the roof whenever possible.
- 2.3. Each roof drain shall be accompanied by an overflow drain or overflow scupper to allow the roof to drain if the primary drain is not operable.
- 2.4. If storm sewer facilities exist on the site, it is preferable that the primary roof drains empty directly into the storm sewer. If the primary drain is discharged to the surface, the drain shall discharge a minimum of 10 feet from the building onto impervious material. Surface grading shall be such that no water can flow back to the structure. Overflow drains and scuppers must daylight so that it is readily apparent when a primary drain is not operable.

**7080-3. Steep-Slope Roof Drainage**

- 3.1. Steep-slope roofs are to be drained using a gutter and downspout system. Gutters and downspouts shall conform to the *Architectural Sheet Metal Manual* published by the Sheet Metal and Air Conditioning Contractors' National Association (SMACNA). Gutters shall be designed with an open face if icing is expected to occur.
- 3.2. If storm sewer facilities exist on the site, it is preferable that the downspouts drain directly into the storm sewer. If the downspout is discharged to the surface, the drain shall discharge a minimum of 10 feet from the building onto impervious material. Surface grading shall be such that no water can flow back to the structure.
- 3.3. Internal gutters are not allowed under any condition.

**7090-1. General**

- 1.1. Thermal and moisture protection systems are integral to the performance, health, and safety of buildings. The variables that affect the design and selection of these systems for BIA Justice/Detention facilities must be analyzed by the Designer of Record to meet code requirements and energy and LEED goals.

**7090-2. Fire Protection Systems**

- 2.1. Structural building component protection, fire separation, and building penetrations must be designed to conform to the applicable codes described in these guidelines. Fire protection items are paramount in providing general life safety.
- 2.2. All fire-rated components must conform to testing and be certified by Underwriters Laboratories (UL), Warnock Hershey, or be as prescribed in NFPA 5000.
- 2.3. Penetrations through fire-rated assemblies shall be minimized to the greatest extent possible.

**7090-3. Thermal Insulation**

- 3.1. Thermal insulation will depend greatly upon environmental considerations for each specific project.
- 3.2. Building insulation must support the energy consumption goals of the BIA for heating and cooling.
- 3.3. Breaks in the thermal barrier should be avoided whenever possible. The Designer of Record shall provide design and details that allow for continuous insulation for all building components.
- 3.4. All fiberglass insulation shall be formaldehyde free and conform to ASTM C665 Standard Specification for Mineral-Fiber Blanket Thermal Insulation for Light Frame Construction and Manufactured Housing.
- 3.5. Rigid insulation must conform to ASTM C578 Standard Specification for Rigid, Cellular Polystyrene Thermal Insulation.

**7090-4. Air Barriers**

- 4.1. Air barriers are designed to prevent or reduce the flow of air through a building system. In some instances, air barriers may also serve as moisture barriers. An air barrier material must have an air permeance level of 0.004 cubic feet per minute per square foot at 1.57 pounds per square foot or less when tested in accordance with ASTM E2178 Standard Test Method for Air Permeance of Building Materials.
- 4.2. Air barriers must be continuous in order to properly work. The Designer of Record shall detail the building components such that the sealing of seams, penetrations, and openings is indicated.

- 4.3. The design of air barriers shall be closely coordinated with vapor and moisture barriers to ensure that moisture is not trapped in the building envelope.

#### 7090-5. Vapor Retarder

- 5.1. Vapor retarders are designed to restrict the flow of water vapor through a material. Generally, these are placed on the warm side of the insulation. The Designer of Record shall coordinate the location of the vapor barrier with the mechanical designer, because in some climates, a vapor retarder may not be necessary. Vapor barriers shall be 1.0 perm or less when tested with ASTM E96 Standard Test Methods for Water Vapor Transmission of Materials.
- 5.2. Vapor retarders must be continuous. Penetrations, perimeters, and openings through vapor retarders must be sealed to maintain the vapor retarder envelope.

#### 7090-6. Moisture Barrier

- 6.1. Moisture barriers, also known as drainage planes, are designed to prevent the bulk flow of water from such sources as rain and condensation into the building.
- 6.2. Moisture barriers shall be continuous with sealed joints, seams, penetrations, and openings. Flashing shall be incorporated into moisture barrier systems to allow any moisture to escape the wall system.
- 6.3. The design of moisture barriers shall be closely coordinated with vapor retarders and air barriers to ensure that moisture is not trapped in wall assemblies. In some cases, moisture barriers may also be used as air barriers.

#### 7090-7. Flashing

- 7.1. Flashing systems are vital to the integrity of the moisture protection system; the Designer of Record shall take great care when specifying and detailing flashing systems.

##### 7.2. Standards

- 7.2.1. Use the *Architectural Sheet Metal Manual* produced by the Sheet Metal and Air Conditioning Contractors' National Association (SMACNA) as the standard for all roof flashing.
- 7.2.2. The Designer of Record shall note any conflicts between typical manufacturer's details and those illustrated in the SMACNA standards and make recommendations to the BIA.

##### 7.3. Finishes

- 7.3.1. Flashings shall be constructed of one of the following materials:

- Galvanized steel
- Copper
- Stainless steel
- Prefinished aluminum/steel

- 7.3.2. Galvanized steel flashings are not allowed when exposed to public view.
- 7.3.3. Flashing in contact with earth shall be stainless steel.
- 7.3.4. Flashing shall be designed with a slope so that water cannot pond. Slopes must be away from the building except for cap flashings, which should slope toward the roof.

**7100-1. General**

- 1.1. Glazing systems consist of interior and exterior windows and entrance and storefront systems. The information in this section represents a standard of acceptable quality for glazing system components for BIA Justice/Detention facilities.
- 1.2. In general, location and size of glazed openings in detention facility are to be limited. Windows in holding areas should not exceed 5 inches in one dimension unless the opening can be confined to an area of 8 x 8 inches or less. Openings exceeding these dimensional limits should be protected by steel bars or other security elements that effectively reduce the size of the opening.

**7100-2. Exterior Windows**

- 2.1. To the extent possible, windows should be standard manufactured sizes. Custom-size windows should be used sparingly.
- 2.2. Provide detention grade, non-operable windows at detention facility. Locate windows high above floor in strategic location to avoid visual contact to people outside the facility.
- 2.3. Natural lighting is required for detention facility transport and safety cells. Provide a glazed window not less than 3 SF with a view to the exterior.
- 2.4. Window frames in detention facility are to be steel hollow metal. The frames shall have anchors compatible with the partition system in which they are installed. Grout solid frames installed in masonry walls.
- 2.5. Provide insect screening on all operable windows.
- 2.6. Operable sashes shall not project into pedestrian paths.
- 2.7. Windows in food prep areas shall not be operable.
- 2.8. Window construction is to be aluminum and shall meet the following standards and criteria:
  - ANSI/American Architectural Manufacturers Association (AAMA) Heavy Commercial (HC) Class.
  - 6063 aluminum, T5 or better, with a minimum .125-inch extrusion wall.
  - Standard anodized finish.
  - ANSI/AAMA AW-50 rating or better.
  - Cut edges shall be deburred. Sharp edges and protruding screws are prohibited.
  - Window extrusions shall be of thermal break design.
  - Corner joints are to be flush, mitered, rigid, and weatherproof. Joints are to be hairline joints.

- Windows shall drain internally and externally to the building exterior. Provide weeps in the frame so all water can escape the frame.
  - Window frames must be reinforced at hardware locations.
  - Fasteners throughout are to be stainless steel.
  - Hardware shall be institutional grade and vandal resistant.
- 2.9. Window manufacturers must have a minimum of 10 years experience manufacturing the specified window type.
- 2.10. Weather stripping shall not be exposed when windows are shut. All windows must be provided with appropriate weather stripping:
- For compression type weather stripping, nonferrous spring metal or vinyl gasket
  - For sliding type weather stripping, woven pile wool, polypropylene, or nylon

**7100-3. Interior Windows**

- 3.1. When detailing and specifying interior windows, the Designer of Record must consider fire rating.
- 3.2. Provide detention grade, non-operable windows at detention facility. Locate windows high above floor in strategic location to avoid visual contact to people in other areas of the facility.
- 3.3. Interior window frames are to be steel hollow metal. The frames shall have anchors compatible with the partition system in which they are installed. Grout solid frames installed in masonry walls.
- 3.4. If interior windows are to be fire rated, the preferred method is to use fire-rated glass and frames. The use of wire glass is discouraged. Interior windows must conform to the following standards:
- NFPA 80 Standard for Fire Doors and Other Opening Protectives
  - Underwriters Laboratories (UL) certification
- 3.5. Provide either tempered or laminated safety glass where required by code.

**7100-4. Entry and Storefront Systems**

- 4.1. The Designer of Record shall use standard manufactured systems when detailing and specifying storefront and entry systems.
- 4.2. It is preferable that major building entries be constructed of heavy-duty aluminum with ample vision glass for proper supervision.
- 4.3. Curtain-wall glazing systems are not allowed.
- 4.4. Storefront and entry systems shall be aluminum and shall meet the following requirements:

- 4.4.1. Systems shall meet AAMA standards where information is not specifically called out in this section.
- 4.4.2. Extrusions shall be a minimum of .188-inch-thick 6063-T5 or -T6 aluminum.
- 4.4.3. Reinforcing must be provided at hardware locations.
- 4.4.4. Stiles shall be a minimum of 2 inches thick; narrow stiles are not allowed.
- 4.4.5. Corners shall be constructed with concealed welded reinforcement brackets.
- 4.4.6. Aluminum shall have a standard anodized finish.
- 4.4.7. There shall be center mullions at all double doors.

#### **7100-5. Glass**

- 5.1. Glazing properties are an integral part of the design of low-energy-use buildings and are highly dependent on climate zone and the design of the building and its systems. While building design variables cannot be quantified in a design standards document, climate zones can be. Therefore, the recommended glazing properties are specific to each of the seven climate zones described in the *National Best Practices Manual*, published by the U.S. Department of Energy.
- 5.2. Although these values should be considered minimum standards, they may be adjusted for individual projects if the Designer of Record can demonstrate that, due to the design of the building and/or building systems, additional energy savings can be achieved by doing so.
- 5.3. Figure 7100-1 outlines the recommended glazing properties for the BIA design standards. These values are based upon exceeding ASHRAE 90.1 requirements by approximately 30 percent.

#### **7100-6. Detention Glazing Systems**

- 6.1. Security windows should comply with ASTM A 627 Standard for Test Methods for Tool Resisting Steel Bars, Flats and Shapes for Detention and Correctional Facilities. Glazing for the windows if the opening is larger than 5 inches wide should comply with ASTM 1915 Standard Test Methods for Glazing Detention Facilities or ASTM F 1233 Standard Test Methods for Security Glazing Materials and Systems. If the opening in the window is 5 inches or less, then tempered glass could be used either single pane or in an insulated glass unit, whichever is required to meet the environmental conditions.



Figure 7100-1: Recommended Glazing Properties

| Climate Zone <sup>1</sup> | Description       | Representative City | ASHRAE Climate Zone <sup>2</sup> | Property | Maximum Value <sup>3,4</sup> |
|---------------------------|-------------------|---------------------|----------------------------------|----------|------------------------------|
| 1                         | Hot & humid       | Orlando             | 2A                               | U-Value  | fixed 0.94<br>operable 0.98  |
|                           |                   |                     |                                  | SHGC     | all 0.17<br>north 0.44       |
|                           |                   |                     |                                  |          |                              |
| 2                         | Temperate & humid | Atlanta             | 3A                               | U-Value  | fixed 0.42<br>operable 0.47  |
|                           |                   |                     |                                  | SHGC     | all 0.19<br>north 0.26       |
|                           |                   |                     |                                  |          |                              |
| 3                         | Cool & humid      | Boston              | 5                                | U-Value  | fixed 0.42<br>operable 0.47  |
|                           |                   |                     |                                  | SHGC     | all 0.26<br>north 0.36       |
|                           |                   |                     |                                  |          |                              |
| 4                         | Cold & humid      | Minneapolis         | 6A                               | U-Value  | fixed 0.42<br>operable 0.47  |
|                           |                   |                     |                                  | SHGC     | all 0.26<br>north 0.38       |
|                           |                   |                     |                                  |          |                              |
| 5                         | Hot & dry         | Phoenix             | 2B                               | U-Value  | fixed 0.94<br>operable 0.98  |
|                           |                   |                     |                                  | SHGC     | all 0.17<br>north 0.44       |
|                           |                   |                     |                                  |          |                              |
| 6                         | Cool & dry        | Denver              | 5B                               | U-Value  | fixed 0.42<br>operable 0.47  |
|                           |                   |                     |                                  | SHGC     | all 0.26<br>north 0.36       |
|                           |                   |                     |                                  |          |                              |
| 7                         | Temperate & mixed | Seattle             | 4C                               | U-Value  | fixed 0.42<br>operable 0.47  |
|                           |                   |                     |                                  | SHGC     | all 0.25<br>north 0.36       |
|                           |                   |                     |                                  |          |                              |

**Notes:**

1. Climate zones are as established by the U.S. Department of Energy.
2. Corresponding ASHRAE climate zone for representative city from ASHRAE 90.1 Energy Standard for Buildings Except Low-Rise Residential Buildings.
3. *U-Value* = thermal conductance (Btu/hr-sf-F), *SHGC* = Solar Heat Gain Coefficient (unitless), *fixed* = fixed window, *operable* = operable window, *all* = all orientations except north, *north* = north orientation.

- 6.2. In addition to energy-use goals, each project will also have certain aesthetic and design objectives. Consequently, it is the responsibility of the Designer of Record to make the final determination of glass type within the framework of these guidelines. In order to achieve these goals, the following considerations apply:
- 6.2.1. Exterior glass shall meet the minimum performance criteria shown in Figure 7100-1. Glass criteria shall be analyzed in conjunction with the building envelope for overall energy performance of the building. Exterior glazing shall be, at minimum, 1-inch insulated units.
  - 6.2.2. Special performance-enhancing coatings shall be considered. Glazing types for each building will be limited to two types for ease of maintenance.
  - 6.2.3. Provide detention grade security glazing at detention facility.
  - 6.2.4. Spandrel glass will be insulated units with the coating on the #3 surface.
  - 6.2.5. All glass in and around doors as well as locations specified in the code shall be tempered or laminated safety glass.

#### 7100-7. Flashing

- 7.1. Flashing systems are vital to the integrity of the moisture protection system; the Designer of Record shall take great care when specifying and detailing flashing systems.
- 7.2. Flashing at windows shall be provided with an upturned leg on the interior of the window. Such flashings will also incorporate end dams.
- 7.3. Where flashing over masonry without precast or cast stone sills, continuous sheet metal flashing shall extend the full depth of the masonry and turn down. Unflashed masonry sills are not allowed.

#### 7.4. Standards

- 7.4.1. Use the *Architectural Sheet Metal Manual* produced by the Sheet Metal and Air Conditioning Contractors' National Association (SMACNA) as the standard for all roof flashing.
- 7.4.2. The Designer of Record shall note any conflicts between typical manufacturer's details and those illustrated in the SMACNA standards and make recommendations to the BIA.

#### 7.5. Finishes

- 7.5.1. Flashings shall be constructed of one of the following materials:
  - Galvanized steel
  - Copper
  - Stainless steel

- Prefinished aluminum/steel
- 7.5.2.** Galvanized steel flashings are not allowed when exposed to public view.
- 7.5.3.** Flashing in contact with earth shall be stainless steel.
- 7.5.4.** Flashing shall be designed with a slope so that water cannot pond. Slopes must be away from the building except for cap flashing, which should slope toward the roof.

**7110-1. Introduction**

- 1.1. This section provides an overview of daylighting strategies that can be incorporated into the design of BIA Justice / Detention facilities. Daylight can be provided via windows and glazed doors, as well as via clerestories and other forms of toplighting. These glazed openings are collectively referred to as “fenestration.” The placement, design, and selection of materials for fenestration are extremely important and can make the difference between a high-performance and low-performance building. Fenestration impacts building energy efficiency by affecting cooling loads, heating loads, and lighting loads. Visual comfort is strongly affected by window location, shading, and glazing materials. Well-designed windows can be a visual delight. But poorly designed windows can create a major source of glare. Thermal comfort can also be compromised by poor fenestration design.

**7110-2. Daylighting in Detention Facility**

- 2.1. Location and size of glazed openings in detention facility intake and holding areas are limited.
- 2.2. Penetrations in the walls and roofs, ceilings should not exceed 5 inches in one dimension unless the opening can be confined to an area of 8 x 8 inches or less. Openings exceeding these dimensional limits should be protected by steel bars or other security elements that effectively reduce the size of the opening.
- 2.3. Locate windows high above floor in strategic location to avoid visual contact to people outside the facility.
- 2.4. Locate shading devices 10 feet above grade in strategic location to discourage unauthorized access to roofs.

**7110-3. Benefits of Daylighting**

- 3.1. There are several advantages to the use of daylight in justice/detention facilities. Daylight contributes to:
  - Energy savings
  - Better light
  - Connection to nature
  - Improved health
  - Environmental education to the public

**7110-4. Basic Daylighting Principles**

- 4.1. These six principles should be followed when designing daylit justice/detention facilities:
  - Prevent direct sunlight penetration into glare-sensitive spaces.
  - Provide gentle, uniform light throughout each space.

- Avoid creating sources of glare.
- Allow staff to control the daylight with operable louvers or blinds.
- Design the electric lighting system to complement the daylighting design, and encourage maximum energy savings through the use of lighting controls.
- Plan the layout of interior spaces to take advantage of daylight conditions.

#### 7110-5. Daylighting Strategies

5.1. The following are acceptable daylighting strategies that may be incorporated in the design of justice / detention facilities:

##### 5.1.1. *Sidelighting*

- 5.1.1.1. Sidelighting allows daylight to enter through windows in vertical walls. With windows, uniform illuminance is more difficult to provide, because there is always more light next to the window. Glare is also more difficult to control. But there are design techniques that can substantially reduce problems associated with sidelighting.
- 5.1.1.2. The depth of daylighting penetration from vertical windows is largely dependent on the height of the window head. For a simple sidelighting scheme, a rough rule of thumb is that usable daylight will be available about 1½ times the window head height. So for good daylight delivery, sidelighting windows should be located as high as possible in the wall. However, to provide exterior views, windows need to be at eye level. Since these requirements clearly conflict, advanced daylighting designs differentiate between the functions of view and task daylighting, frequently providing separate windows for each.
- 5.1.1.3. The orientation of a sidelighting aperture strongly affects the quantity, quality, and distribution of daylight. For sidelighting and no shading, north-facing windows provide the most even illuminance. The quantity of light is diminished, but a larger aperture will compensate, providing adequate and more even illumination.
- 5.1.1.4. Whenever possible, orient view windows toward the north or south to avoid low-angle east/west sun. Up to 15 degrees variance from true north or south is acceptable, but will reduce performance.
- 5.1.1.5. Angled ceilings in combination with high sidelighting will bring daylight farther back into the room. Careful integration of the structural system, HVAC ducts, and lighting in the plenum space is required.

### 5.1.2. *Exterior Shading Devices*

- 5.1.2.1.** Shading devices for sidelighting strategies minimize solar gains and glare, and can also be designed to increase illumination levels. Shading devices—both overhangs and fins—can be either opaque or translucent, and solid or louvered. It is best to place shading devices outside the glazing to stop solar gains before they hit the window and to reduce potential glare from bright window views.
- 5.1.2.2.** Exterior overhangs should be deep enough to minimize direct sun on the window for the hottest hours of the day during the cooling season. For south-facing windows in sunny (clear sky) climates with very high air-conditioning loads, a good rule of thumb is to design the overhang with a shading cutoff angle about equal to 90 degrees minus the site latitude. This provides full shading between March 21 and September 21. Overhangs for climates with lower air-conditioning loads and/or more summer overcast can increase this angle by 5 to 15 degrees. Overhangs or fins for windows facing east or west do not lend themselves to simple rules of thumb and should be carefully designed for the specific site, climate, and space. North-facing windows usually do not need exterior overhangs or finish, but may occasionally require interior blinds or louvers to control glare.

### 5.1.3. *Interior Shading Devices*

- 5.1.3.1.** Interior shading devices for windows reduce solar heat gain somewhat but are most effective at controlling glare. The most common interior glare control devices are horizontal mini-blinds, vertical blinds, shade screens, and curtains.

### 5.1.4. *Toplighting*

- 5.1.4.1.** Providing daylight from above generically referred to as “toplighting” can generally create the most uniform illumination throughout a space. Examples of toplighting strategies include roof monitors and tubular skylights. Roof monitors must utilize vertical or high-slope glazing. South facing vertical glazing tends to be the most efficient in terms of optimizing yearly heating and cooling balance.
- 5.1.4.2.** Unit skylights utilizing multiple pieces of glazing are *not permitted* under these guidelines. Due to long-term maintenance concerns and the potential for leakage, these systems are not allowed.
- 5.1.4.3.** Small, single-opening skylights are permitted. These can be installed in patterns to create even, low-glare illumination across a large area.
- 5.1.4.4.** Tubular skylights for use in areas with relatively deep roof cavities are permitted.

- 5.1.4.5. All toplighting schemes represent penetrations through the roof diaphragm, which is often a critical part of the building's structural system. Similarly, toplighting apertures may intersect with HVAC ducting, electrical lighting layouts, and fire sprinkler systems. Careful coordination of the structural, mechanical, and electrical designs will ensure compatibility among these systems.

**7120-1. General**

1.1. Because doors in Justice/Detention facilities are subject to a great amount of use and possible abuse, they must be durable and low maintenance. This section will discuss the types of doors suitable for BIA Justice / Detention facilities and establish the door criteria to be considered and met by the Designer of Record.

1.2.

**7120-2. Fire Ratings**

2.1. All rated doors and frames must meet the requirements of the following:

- NFPA 80 Standard for Fire Doors and Other Opening Protectives
- Underwriters Laboratories (UL)

2.2. All rated doors and frames must be provided with fire labels.

**7120-3. Interior Doors**

3.1. Two main interior door types will be used in BIA Justice/Detention facilities; general use doors and high abuse doors.

3.1.1. General use doors include those leading into offices, restroom facilities, and other locations used for non-service and equipment use. The following considerations apply to general use doors:

- General use doors shall be solid core wood. Wood doors should be finished with a light-color stain so as not to show scratches and abrasions.
- Vision panels are required on doors leading into public spaces. These allow for safe entry and exit as well as observation. Vision panels in dorm rooms are not required. The glass in the vision panel must be tempered or laminated safety glass.
- Steel frames are to be used for all general use doors.

3.1.2. High abuse doors are those located in detention facility; and those leading into service and equipment areas such as mechanical rooms, kitchens, custodial rooms, etc. Provide hollow metal doors with hollow metal steel frames at high abuse doors. Provide detention grade doors and frames at detention facility.

**7120-4. Exterior Doors**

4.1. Exterior doors typically comprise public entrances and service entry doors.

4.1.1. Preferably, public entry doors should be heavy-duty storefront entry systems. The requirements for storefront entry systems are covered in Section 7100.

4.1.2. High abuse doors are those located in detention facility; and those leading into service and equipment areas such as mechanical rooms, kitchens,



custodial rooms, etc. Provide hollow metal doors with hollow metal steel frames at high abuse doors. Provide detention grade doors and frames at detention facility.

**7120-5. Steel Doors**

- 5.1. Typical steel doors shall be ANSI A250.8/SDI-100 Recommended Specifications for Standard Steel Doors and Frames Level 3 Heavy Duty with 16-gauge faces.
- 5.2. Doors subject to heavy use shall be ANSI A250.8/SDI-100 Level 4 Extra Heavy Duty with 14-gauge faces.
- 5.3. For light-duty doors such as in-room closets, ANSI A250.8/SDI-100 Level 1 Standard Duty doors with 18-gauge faces are permitted.
- 5.4. Doors shall be 1¾ inches thick and flush type.
- 5.5. Doors shall be of fully welded construction.
- 5.6. Doors shall be factory reinforced and prepared for hardware attachment.
- 5.7. Standard size doors are preferable.
- 5.8. Exterior doors must be galvanized.
- 5.9. Steel doors are to be factory primed with rust inhibitive primer.
- 5.10. Doors in detention facility are to comply with ASTM F 1450 Standard Test for Hollow Metal Swinging Door Assemblies for Detention Facilities. All doors to be steel, minimum 2 inches thick. Provide internal stiffeners and additional inverted channels to provide edge closures all around. Security grade to be based on the Impact Test of ASTM F 1450. Vision panels in door are to comply with ASTM F 1592 Standard Testing Methods for Detention Hollow Metal Vision Systems.

**7120-6. Wood Doors**

- 6.1. Doors must meet ANSI/Window & Door Manufacturers Association (WDMA) I.S. 1A Industry Standard for Architectural Wood Flush Doors.
- 6.2. Doors shall be Architectural Woodwork Institute (AWI) Quality Standards Extra Heavy Duty grade.
- 6.3. Doors shall be provided with a clear factory finish.
- 6.4. Doors shall be 1¾ inches thick and flush type.
- 6.5. Provide matching edge banding.
- 6.6. Face veneer must be:
  - Premium grade
  - Plain cut
  - Vertical grain

- Slip matched
- 1/50 inch minimum thickness

6.7. Wood doors are not allowed for exterior uses under any circumstance.

**7120-7. Frames**

- 7.1. Exterior frames shall be ANSI A250.8/SDI-100 Level 4 (14 gauge).
- 7.2. Interior frames shall be ANSI A250.8/SDI-100 Level 3 (16 gauge).
- 7.3. Frames shall have continuous welded mitered corners.
- 7.4. Frames shall be factory reinforced and prepared for door hardware.
- 7.5. Frames shall be factory primed with rust inhibiting primer.
- 7.6. Knockdown frames are not permitted.
- 7.7. Provide frame anchors to tie into adjacent construction per Steel Door Institute (SDI) standards.
- 7.8. Frames against masonry or concrete are to be slush filled.
- 7.9. Frames in detention facility are to comply with ASTM F 1450 Standard Test for Hollow Metal Swinging Door Assemblies for Detention Facilities.

**7120-8. Hardware**

- 8.1. Door hardware shall conform to Builders Hardware Manufacturers Association (BHMA) standards.
- 8.2. Door hardware shall be Grade 1, heavy duty, and vandal resistant.
- 8.3. Provide detention grade hardware throughout detention facility that meets the minimum requirements of ASTM F 1577 Standard Test Methods for Detention Locks for Swinging Doors.
- 8.4. Finishes shall be BHMA standard finish.
- 8.5. Door hardware design and mounting heights will conform to the accessibility standards.
- 8.6. Coordinate keying with the BIA.

**7130-1. General**

- 1.1. Signage systems provide a safe and clear way to navigate through a building structure. Many types of signage are dictated by the accessibility guidelines and codes specified in this handbook. Exiting signs are discussed in Chapter 11, “Electrical.”

**7130-2. Coordination**

- 2.1. The Designer of Record shall include a signage schedule meeting the requirements of this section. It is important for the Designer of Record to coordinate signage locations, materials, colors, and numbering system with the BIA to ensure desirable results. The Designer of Record shall number the rooms on the plans to correspond to the eventual actual room numbers, and try to ensure that existing room signage would not require modification if the building were expanded.

**7130-3. Locations**

- 3.1. Signage shall be located where required by NFPA 5000 and the adopted accessibility codes discussed in Section 1040. Signage locations include but are not limited to restrooms, accessible entries, and locations of vertical circulation.
- 3.2. Exterior building identification signage shall be provided. These signs can be either stand-alone or building-mounted systems. If the signage is building mounted, it shall conform to the following:
  - Finished aluminum
  - 10-inch-high letters
  - Helvetica medium font
- 3.3. Signage shall be provided at each room entry. This room identification sign shall be coordinated with the fire alarm system and building plans and shall have the following information:
  - Room name
  - Room number
- 3.4. Site signage, other than signs required by code, shall be installed to aid in site circulation. Such signage shall be located in all locations where a clear and concise message is needed for wayfinding. Locations for signage not required by code shall include, but not be limited to, the following:
  - Separated or restricted parking areas
  - Directional signage for special building components

**7130-4. Sign Construction**

- 4.1. Signage systems should be durable and vandal resistant.

- 4.2. Room identification signs shall have flexible/removable inserts in permanent fixed frames. The signs shall be provided with a slot for the insertion of occupant or program identification.
- 4.3. Signs shall be 1/4-inch thick, integrally colored solid acrylic plastic.
- 4.4. For raised characters (tactile), letter height shall be not less than 1/32-inch thick. These characters can be etched, routed, or pin-mounted.
- 4.5. Die-cut characters shall be cut from vinyl film and applied to the face of acrylic plastic.
- 4.6. Provide Grade II Braille lettering.
- 4.7. Provide lettering in contrasting levels to meet accessibility standards.

**7130-5. Installation**

- 5.1. Install signage at heights and locations required to meet accessibility standards.
- 5.2. Install signage per manufacturer's recommended methods.

**8000-1. Introduction**

- 1.1. This chapter, in conjunction with the *BIA Justice/Detention Facilities Space Templates*, provides guidelines for developing attractive and effective building interiors for all new BIA Justice/Detention Facilities. The design of BIA Justice/Detention Facility interiors shall be in conformance with these guidelines unless exceptions to them are granted by the BIA.
- 1.2. Justice and detention facilities must be durable, perform well acoustically, provide a healthy environment, and be easy and economical to maintain. To that end, their design should be based upon recognized and sound commercial building practices.
- 1.3. Refer to Chapter 1, “General Information,” and Chapter 2, “Presentation of Data,” for required documents, drawing and specifications formats, and other design and submittal requirements not discussed in this chapter.
- 1.4. Additional design and submittal requirements may apply for projects with unusual or highly technical criteria.
- 1.5. As applicable, the Designer of Record shall incorporate the sustainability strategies identified in Chapter 3, “LEED Goals and Guidelines.”
- 1.6. The guidelines in this chapter should be used in conjunction with those in the other chapters in this handbook, and the Designer of Record should coordinate with the other project consultants to be sure all aspects of the justice/detention facility are effective and compatible.
- 1.7. All design features must be weighed carefully for their initial cost, long-term maintenance cost and needs, durability, and their impact on the environment.

**8000-2. Content**

- 2.1. The following sections present the considerations to analyze before final selection of interior elements. These guidelines are not meant to unduly limit the design process; rather, they are intended to ensure a consistent level of quality for all facilities.

**8000-3. Compliance Requirements**

- 3.1. It is recognized that not all design professionals will agree with the choice of the interior systems and materials discussed and presented in this chapter and in the space templates. However, the items included have been identified through comprehensive performance evaluations and meet the goals of the BIA for their Justice/Detention facilities. Consequently, the Designer of Record is required to use the specified systems and materials unless permission to do otherwise is stated in the following sections or in the *BIA Justice/Detention Facilities Space Templates*.

**8010-1. Role of the Designer of Record in Systems Selection**

- 1.1. While the guidelines in this chapter and in the *BIA Justice/Detention Facilities Space Templates* present a selection of preapproved interior finish systems, it is ultimately the responsibility of the Designer of Record to determine which of the pre-approved systems is most appropriate for any given project. The Designer of Record must analyze the various considerations included within the individual systems sections to make final recommendations to the BIA. It is not the role of the Designer of Record to analyze components outside of the preapproved systems unless allowed elsewhere in this chapter or in the space templates to do so.

**8010-2. Considerations**

- 2.1. This chapter and the space criteria sheets in the space templates volume provide the Designer of Record with a menu of approved interior finish systems that meet the BIA performance standards. In most cases, the Designer of Record will have more than one option to select from.
- 2.2. These guidelines recognize that many variables exist, depending upon market conditions, regional considerations, and design concepts. In selecting interior finish systems, considerations for the Designer of Record to analyze include, but are not limited to:
  - First costs
  - Lifetime costs
  - Expected system life
  - Maintenance
  - Durability
  - Local availability
  - Local expertise
  - Local tribal customs and heritage
  - LEED compliance
  - Energy and resource conservation
  - Climate
  - Schedule
  - Acoustics
  - Aesthetics
  - Fire ratings

**8020-1. General**

- 1.1. For the design of interiors, follow all applicable current codes, standards, and laws. For a more general list of codes and standards that apply to BIA Justice/Detention facilities, refer to Chapter 1, “General Information.” During design, report any required deviations from codes and standards to the Contracting Officer.
- 1.2. Where two codes, standards, or laws are applicable to the topic under review, use the more conservative or more stringent. Consult with the BIA Office of Facilities Management and Construction (OFMC) to resolve any questions or conflicts regarding application of codes and standards.

**8020-2. Applicable Codes and Standards**

- 2.1. The design criteria shall also comply with the guidelines published by or contained in the following:
  - NFPA 5000 Building Construction and Safety Code – Requirements for finish ratings for interior materials.

**8030-1. General**

- 1.1. Wall finishes in BIA Justice/Detention facilities are required to be durable and cost effective and create a pleasing and healthy justice/detention facility environment. Considerations for the selection of finish materials are listed in Section 8010.

**8030-2. Working with the Space Criteria Sheets**

- 2.1. The BIA *Justice/Detention Facilities Space Templates* volume contains space criteria sheets for all major spaces that may be required in BIA Justice / Detention facilities. The space criteria sheets show a group of acceptable finish materials for each space. Each of the materials listed has been deemed acceptable by the BIA and determined to meet necessary quality, durability, and functional requirements. It is the role of the Designer of Record to analyze and select a finish material from the given list that is most appropriate for the project at hand. The range of materials listed is intended to provide the designer with a limited freedom to express a design aesthetic as well as local and regional influences.

**8030-3. LEED Coordination**

- 3.1. Finish materials and methods shall be investigated and chosen by the Designer of Record to help achieve the BIA's Leadership in Energy and Environmental Design (LEED) objectives as outlined in Chapter 3.

**8030-4. Acoustics**

- 4.1. Acoustics play a major role in healthy and effective justice/detention facility environments. The Designer of Record shall ensure that the acoustical performance requirements described in Section 7040 are met. In many cases this will impact the choice of finish materials.
- 4.2. In spaces with no ceilings and that are consequently exposed to structure, the Designer of Record shall perform an acoustical analysis to confirm acoustical performance as required by this handbook. In some cases, acoustical design strategies such as acoustical structural decking, batts, or baffles may be required. The Designer of Record will have final responsibility to meet acoustical requirements.

**8030-5. Special finish requirements in detention facility, safety cells, interview rooms and dayrooms.**

- 5.1. Finishes shall be durable and require little maintenance. Approved finishes for floors, walls, and ceilings are listed below.

**5.1.1. Floors**

- Sealed concrete



**5.1.2. Walls**

- Painted concrete masonry units (CMUs)

**5.1.3. Ceilings**

- Painted abuse-resistant gypsum board.
- Detention grade perforated metal panel ceiling.
- Secured, plywood backed suspended ceiling with vinyl faced panels.

**5.2.** Applied wall base is prohibited.

**5.3.** Sealants: Shore A or Shore D hardness.

**5.4.** Security Fasteners: Provide one type of security fastener, such as torx head, to simplify maintenance and the number of tools necessary for removal

**8040-1. General**

- 1.1. Corridor design is critical to efficient and safe circulation throughout Justice/Detention facilities. The design of corridors will vary depending upon the grade levels housed in the building.

**8040-2. Corridor Width**

- 2.1. The minimum width for primary corridors is 8 feet clear.
- 2.2. The width of primary corridors should not restrict to below the required clearance at any point.
- 2.3. The Designer of Record shall analyze code requirements and traffic loads to determine minimum corridor widths in nonprimary corridors.
- 2.4. In all cases, corridor widths shall conform to code-related exiting requirements.

**8040-3. Corridor Finishes**

- 3.1. Finishes for justice facility corridors shall be durable and require little maintenance. Approved finishes for floors, walls, and ceilings for justice facilities are listed below.

**3.1.1. Floors**

- Carpet
- Sheet vinyl/linoleum
- Vinyl composition tile (VCT)
- Sealed concrete

**3.1.2. Walls**

- Painted concrete masonry units (CMUs)
- Ground face/integrally colored CMUs
- Painted abuse-resistant gypsum board

**3.1.3. Ceilings**

- Painted gypsum board
- Acoustical lay-in tile system

- 3.2. Finishes for detention facility corridors shall be durable and require little maintenance. Approved finishes for floors, walls, and ceilings for detention facilities are listed below.

**3.2.1. Floors**

- Sealed concrete

**3.2.2. Walls**

- Painted concrete masonry units (CMUs)
- Ground face/integrally colored CMUs

**3.2.3. Ceilings**

- Painted abuse-resistant gypsum board.
- Detention grade perforated metal panel ceiling.
- Secured, plywood backed suspended ceiling with vinyl faced panels.

**9000-1. Introduction**

- 1.1. This chapter provides structural design criteria, requirements, and guidance for all new BIA Justice/Detention projects. The design shall be in conformance with these guidelines unless exceptions to them are granted by the BIA.
- 1.2. Refer to Chapter 1, “General Information,” and Chapter 2, “Presentation of Data,” for required documents, drawing and specifications formats, and other design and submittal requirements not discussed in this chapter.
- 1.3. Additional design and submittal requirements may apply for projects with unusual or highly technical criteria.
- 1.4. As applicable, the Designer of Record shall incorporate the sustainability strategies identified in Chapter 3, “LEED Goals and Guidelines.”
- 1.5. The guidelines in this chapter should be used in conjunction with those in the other chapters in this handbook, and the Designer of Record should coordinate with the other project consultants to be sure all aspects of the justice / detention facility are effective and compatible.
- 1.6. All design features must be weighed carefully for their initial cost, long-term maintenance cost and needs, durability, and their impact on the environment.

**9000-2. Personnel Qualifications**

- 2.1. Structural engineers designing or performing structural evaluations for BIA projects must be licensed and qualified by education and relevant experience. All documents must meet professional engineering standards and be stamped by a professional engineer registered in the state of the project.

**9010-1. All Structures**

- 1.1. Consider the following factors in the selection of structural and building enclosure systems for BIA Justice/Detention facilities:
  - 1.1.1. Life-cycle costs, safety, durability, constructability, availability of materials, and aesthetic considerations.
  - 1.1.2. Total initial cost, including materials costs, transportation costs, and labor costs.
  - 1.1.3. Constructability, including speed of construction and impact on project construction schedule, simplicity of construction, the number of trades required to build the structure, and the required interaction among trades. Fewer structural trades are preferred.
  - 1.1.4. Structural performance including load capacity, span range, deflection, vibration, and acoustics.
  - 1.1.5. Local availability of construction materials.
  - 1.1.6. Local expertise, including knowledge, experience, and expertise with construction materials and methods.
  - 1.1.7. Local construction season. Where local conditions exist that limit the length of the construction season, consider using construction practices that will allow for rapid completion of the building (road restrictions, for example, may prevent truck hauling during the spring thaw). These practices include prefabricated construction and structural systems that can be erected over the winter.
  - 1.1.8. Building systems accommodation, including mechanical, electrical, and plumbing systems; capability of supporting mechanical equipment; and accommodation of conduit and ductwork routing, lighting, ceilings, moving partitions, and other hung loads.
  - 1.1.9. Structural durability, including corrosion, decay, and abuse. Consider maintenance and expected system life.
  - 1.1.10. Flexibility for future modifications, including mechanical equipment; floor, roof, and wall openings; future hung partitions; future increased loading; and future adjacent additions.
  - 1.1.11. Fire resistance, including combustibility of the structural system, fire rating of the structural system, and other materials that may be required to achieve the required fire rating. Use structural systems that achieve the required construction type and fire resistance required by the building code.
  - 1.1.12. Self-weight, with respect to foundations and seismic loads.
  - 1.1.13. Structural depth, with respect to floor-to-floor height and building envelope thickness.

1.1.14. Leadership in Energy and Environmental Design (LEED) compliance, to maximize LEED points.

**9010-2. Justice Facilities**

2.1. Consider the following factors in the selection of systems for justice facilities:

- Large, open, column-free spaces for the cafeteria and court rooms.
- Acoustics
- Vibration from footfall.
- Flexibility for future renovations and modifications.
- External criminal threats such as explosives, small arms, and ramming vehicles.

**9010-3. Detention Facilities**

3.1. Consider the following factors in the selection of systems for detention facilities:

- Durability relative to abuse by the detainees, to reduce maintenance.
- Hardness to prevent detainees from escaping.
- Acoustic transmission through floors and walls.
- External criminal threats such as explosives, small arms, and ramming vehicles.

**9020-1. General**

- 1.1. Design all structural elements in accordance with all applicable current codes, standards, and laws. For a more general list of codes and standards that apply to BIA Justice/Detention facilities, refer to Chapter 1, “General Information.” During design, report any required deviations from codes and standards to the Contracting Officer.
- 1.2. Where two codes, standards, or laws are applicable to the topic under review, use the more conservative or more stringent. Consult with the BIA Office of Facilities Management and Construction (OFMC) to resolve any questions or conflicts regarding application of codes and standards.
- 1.3. NFPA 5000 Building Construction and Safety Code is the primary code to be followed.
- 1.4. The Designer of Record shall be responsible for the adequacy, economy, and serviceability of all structures for which they are assigned design responsibility. Good engineering judgment shall be used in addition to compliance with all applicable codes.

**9020-2. Applicable Codes and Standards**

- 2.1. The design criteria shall comply with the guidelines contained in the following:
  - American Concrete Institute (ACI) 302.1R *Guide for Concrete Floor and Slab Construction*, ACI 318 *Building Code Requirements for Structural Concrete and Commentary*, and ACI 360R *Design of Slabs on Ground*
  - American Institute of Steel Construction (AISC) Design Guide 3 *Serviceability Design Considerations for Steel Buildings* and Design Guide 11 *Floor Vibrations Due to Human Activity*
  - American Iron and Steel Institute (AISI) Standard for Cold-Formed Steel Framing – Lateral Design
  - American National Standards Institute (ANSI)/American Society of Mechanical Engineers (ASME) A17.1 Safety Code for Elevators and Escalators
  - American Society of Civil Engineers (ASCE) 7 *Minimum Design Loads for Buildings and Other Structures* (use the edition referenced by NFPA 5000)
  - Applied Technology Council (ATC) Design Guide 1 *Minimizing Floor Vibration*
  - Federal Emergency Management Agency (FEMA) 361 *Design and Construction Guidance for Community Shelters*
  - Metal Building Manufacturers Association (MBMA) *Metal Building Systems Manual*

- National Fire Protection Association (NFPA) 5000 Building Construction and Safety Code
- Occupational Safety & Health Administration (OSHA) Part 1926 Safety and Health Regulations for Construction
- NFPA1221, “Standard for the Installation, Maintenance, and Use of Emergency Services Communications Systems”

### 9020-3. Local Practices

- 3.1. The codes and requirements herein take precedence over local and tribal codes or laws. The exception to this is local jurisdiction requirements for snow loads and wind speed, which shall be used if larger than those required by NFPA 5000. Other local design practices that are of special interest include local foundation systems, commonly used structural systems and materials, and accommodations for temperature range.

### 9020-4. Design Loads

- 4.1. All loads shall be determined according to NPFA 5000 and ASCE 7. All dead, live, snow, wind, seismic, soil, temperature, rain, and ice loads shall be shown on the design drawings.

#### 4.2. Dead Loads

- 4.2.1. Design the structure using at least 10 pounds per square foot hung load for ceilings, lights, and mechanical loads.
- 4.2.2. In mechanical rooms and mechanical penthouses, design the structure above using 25 pounds per square foot hung load for piping and equipment, in addition to specific mechanical equipment loads.
- 4.2.3. Moveable walls must be supported from the structure above. Use the weight provided by the manufacturer. Consider the concentrated effects of the wall in its stacked position. The stiffness of the supporting structure shall be compatible with the clearance at the base of the wall.
- 4.2.4. For structures supporting mechanical equipment, design for 125 percent of the operating weight of the equipment to account for possible equipment substitutions during construction and future equipment replacement or modifications. Mechanical penthouses require a concrete floor for acoustics and a concrete housekeeping pad under the equipment for maintenance. Include the weight of the concrete pad in the dead load.

#### 4.3. Live Loads

- 4.3.1. Minimum live loads shall be determined according to ASCE 7.
- 4.3.2. For interstitial spaces and penthouses, use a minimum live load of 40 pounds per square foot (and a 1,000-pound point load) in the spaces around the equipment.



**4.4. Snow Loads**

- 4.4.1. Determine snow loads in accordance with ASCE 7.
- 4.4.2. In regions of high variability as shown on the ASCE 7 map, obtain snow load information from local building officials.
- 4.4.3. Consider unbalanced snow load, snow drifts at lower roofs and projections, roof valley snow drifting, ice dams, and sliding snow as appropriate, in accordance with ASCE 7. New roofs shall not be built adjacent to existing lower roofs without structural modifications to the existing lower roof to avoid overloading the existing roof with drifted snow.

**4.5. Wind Loads**

- 4.5.1. Determine wind loads in accordance with ASCE 7.
- 4.5.2. In special wind regions as shown in ASCE 7, obtain wind load information from local building officials.
- 4.5.3. In hurricane-susceptible regions, Justice / Detention facilities need *not* be designed as designated hurricane shelters. The appropriate Importance Factor based on the Structural Occupancy Category shall be used.
- 4.5.4. In tornado-prone regions, tornado shelters are not required in Justice / Detention facilities, subject to written direction by the BIA. The BIA will evaluate this on a case-by-case basis. Tornado-prone regions include those in Zones III and IV, and hurricane-susceptible regions are as shown in Figure 2-2 in FEMA 361. Design of tornado shelters, if so directed, shall be in accordance with FEMA 361. See Figure 9020-1.

**4.6. Seismic Loads**

- 4.6.1. Determine seismic loads in accordance with ASCE 7.

**4.7. Soil Loads**

- 4.7.1. Soil loads acting on the structure shall be obtained from the recommendations provided by the geotechnical engineer. Each project shall be provided with a geotechnical report from the BIA.

**4.8. Temperature Loads**

- 4.8.1. Structures shall be designed for thermal effects, including expansion and contraction of structural and nonstructural components.

**4.9. Rain Loads**

- 4.9.1. Determine rain load in accordance with ASCE 7.
- 4.9.2. Ponding instability shall be prevented.
- 4.9.3. Intentional ponding on the roof for detention purposes is not allowed.

#### 4.10. Ice Loads

4.10.1. Ice-sensitive structures, such as guy wires, shall be designed for ice loads in accordance with ASCE 7.

#### 9020-5. Material-Specific Requirements

- 5.1. All material-specific structural requirements are described in NFPA 5000, Chapters 41 through 45, and the appropriate material-specific codes and standards referenced by NFPA 5000.
- 5.2. The following exceptions, modifications, and exclusions are made to NFPA 5000:
- 5.2.1. *Section 41.6.2* – The slab-on-ground minimum thickness shall be 4 inches.
  - 5.2.2. *Section 41.8* – Gypsum concrete shall not be permitted for structural use in BIA facilities.
  - 5.2.3. *Chapter 43* – Unreinforced masonry shall not be permitted for use.
  - 5.2.4. *Chapter 43* – The use of masonry below grade is permitted only if the underground space is unoccupied. All masonry below grade shall be solid grouted with open-end units. See Figure 9020-2.
  - 5.2.5. *Chapter 43* – Reinforced masonry shall be specified with the following minimum reinforcement requirements:

Vertical reinforcement of at least 0.2 square inches in cross-sectional area shall be provided at corners, within 16 inches of each side of openings, within 8 inches of each side of movement joints, within 8 inches of the ends of walls, and at a maximum spacing of 10 feet.

Reinforcement adjacent to openings need not be provided for openings smaller than 16 inches in either the horizontal or vertical direction, unless the spacing of distributed reinforcement is interrupted by such openings.

Horizontal joint reinforcement shall consist of at least two wires of W1.7 spaced not more than 16 inches, or bond beam reinforcement shall be provided of at least 0.2 square inches in cross-sectional area spaced not more than 10 feet.

Horizontal reinforcement shall also be provided at the bottom and top of wall openings and shall extend not less than 24 inches nor less than 40 bar diameters past the opening; continuously at structurally connected roof and floor levels; and within 16 inches of the top of walls. This reinforcing is the minimum to control cracking.

Masonry walls used in detention cells have additional reinforcing and grout requirements.
  - 5.2.6. *Chapter 45* – Light frame wood construction is not permitted. Glue-laminated timber construction, laminated timber decking, and structural wood sheathing are permitted in Justice Facilities.

**9020-6. Quality Assurance**

- 6.1. A quality assurance program is required for all structures. The Designer of Record shall define the observations, special inspections, tests, and other procedures that provide an independent record to the BIA and the Designer of Record that the construction is in general conformance with the approved construction documents.
- 6.2. Quality assurance procedures, inspections, and testing shall be as stated in NPFA 5000, Chapter 40, with the following clarifications:
  - 6.2.1. The “owner” shall be the Bureau of Indian Affairs (BIA).
  - 6.2.2. The “authority having jurisdiction” shall be the Bureau of Indian Affairs Division of Safety and Risk Management.
  - 6.2.3. Inspection and testing agencies shall be hired by and paid for by the BIA.

**6.3. Geotechnical Certification Letter**

- 6.3.1. Provide to the BIA a letter of certification stamped and signed by the project Designer of Record, stating that the foundation design meets the stated requirements herein and complies with the recommendations of the project geotechnical report.

Figure 9020-1: Tornado-Prone Regions (from FEMA 361)

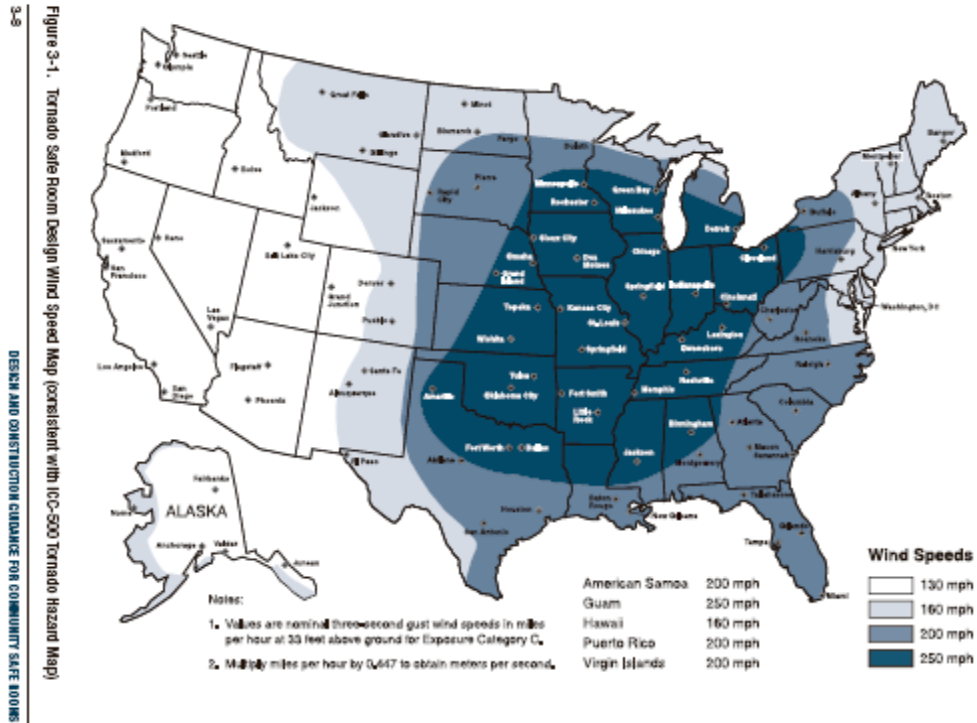
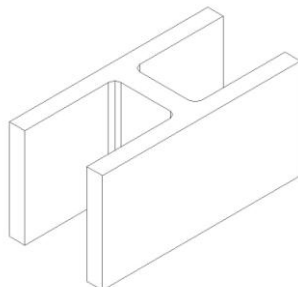

Figure 9020-2: Open-End Concrete Masonry Unit (CMU)



**9030-1. General**

- 1.1. Structural systems shall be selected on the basis of performance, life cycle costs, safety, maintenance, durability, constructability, availability of materials, coordination and accommodation of other building systems, and aesthetic considerations.
- 1.2. Expansion joints shall be provided in building elements as required to reduce the effects of thermal loads and isolate for seismic movement.
- 1.3. For structures that are anticipated to be renovated or expanded in the future, provide structural elements capable of resisting future loads. The drawings shall identify the location and loading assumptions of future expansions.

**9030-2. Remote Site Considerations**

- 2.1. Many BIA Justice / Detention sites are located far from facilities that provide construction materials or populations that provide certain labor skills. Consider the effects of lengthy transportation of products, such as delaying the set of ready-mixed concrete, and selecting precast concrete components that are optimized for transportation size and weight. Use simple, interchangeable rebar, formwork, and other products to reduce special trips from the material supplier. Specialized labor skills that may not be available include concrete post-tensioning, steel welding, and structural systems that require specialized extensive inspection for quality control.

**9030-3. Corrosion**

- 3.1. Consider the durability of structural elements subject to corrosion.
- 3.2. Refer to ACI 318 for concrete subject to corrosive salt and sulfate requirements. Do not place black rebar in exterior stair nosings.
- 3.3. Exterior carbon steel exposed to weather shall be protected with one of the following systems, as a minimum:
  - 3.3.1. Hot-dip galvanized per ASTM A123.
  - 3.3.2. Protected with an appropriate Society for Protective Coatings (SSPC) paint system and steel surfaces prepared using SSPC surface preparation SP-6 Commercial Blast Cleaning, or an equivalent or superior system.
- 3.4. If metal deck is used in exterior applications, the deck shall be specified with G90, minimum, coating and shall be 20 gauge or thicker.
- 3.5. Metal decking in interior applications in humid parts of the country shall be galvanized G60, minimum. Humid areas are defined as those that receive an average of 30 inches or more of precipitation annually, or those that are within 10 miles of an ocean. For average annual precipitation data, see <http://nationalatlas.gov/>
- 3.6. Steel lintels in exterior walls shall be hot-dip galvanized.

**9030-4. Foundation Systems**

**4.1. General Structural Considerations**

- 4.1.1.** The Designer of Record shall review foundation systems recommendations as provided by the geotechnical engineer, in accordance with Section 4120, “Geotechnical Evaluation,” and shall recommend a foundation type, based upon an economical and performance-based comparison of the recommended systems. Consider and discuss local construction practices, risk, and cost in written recommendations to the BIA for their review and approval.
- 4.1.2.** Many BIA sites have expansive soils or poor soil-bearing pressure. The Designer of Record shall be sensitive to this issue and recognize that soil movement can often cause substantial building damage. The Designer of Record shall provide a foundation system to prevent damage. Past solutions to this problem include providing a deep foundation that will not move with soil movement, a mat foundation that can reduce the damaging effects of soil movement, or providing a flexible superstructure and finishes that can accommodate foundation movement. Brittle structures and finishes should be used only if they are compatible with the expected soil and foundation movement.
- 4.1.3.** At sites where the geotechnical report indicates that expansive soils or settlement potential are present, consider whether the movement of a concrete slab on grade is within acceptable limits. If not, provide alternate solutions. Past solutions for this problem include modifying the soil properties below the slab, providing a structural floor capable of spanning to nonmoving supports, or a mat foundation that also serves as the floor. Also consider the effect of expansive soil or settlement potential on below-grade utility connections.
- 4.1.4.** Where the geotechnical report indicates that slabs on grade are a recommended floor system, design and detail slabs on grade in accordance with ACI 302.1R and 360R. The use of underslab vapor barriers shall be considered and installed in accordance with ACI recommendations.
- 4.1.5.** Design and detail slabs on grade and mat foundations for radon mitigation, where required, in conformance with NFPA 5000, Chapter 49.
- 4.1.6.** The effect of groundwater on foundation systems shall be considered, both during construction and during the design life. Construction below the highest potential groundwater elevation shall be protected by a redundant dewatering system, or shall be made watertight and designed for the effects of hydrostatic loads and buoyancy.

- 4.1.7. In areas of deep fill, or at sites where the geotechnical report indicates collapsible soils, consider whether structures, including slabs on grade and site structures and sidewalks, will be damaged by settlement. If damaging settlement is likely to occur, provide alternate solutions that prevent damaging movements. Also consider the effect of settlement on below-grade utility connections. Deep fill includes a depth of fill that exceeds 6 feet.
- 4.1.8. Foundation walls shall be constructed of reinforced masonry or reinforced concrete and designed in accordance with NFPA 5000. See Section 9020 for limitations on below-grade masonry construction.
- 4.1.9. Thresholds at exterior doors shall be detailed to provide support for site slabs such that the outward door swing is not impeded by frost heave or heave of expansive soils, and such that a tripping hazard due to a vertical offset between the interior and exterior slabs is prevented. A structured stoop slab is often required.
- 4.1.10. See Section 5030, "Site Design and Earthwork," for site retaining walls.
- 4.2. **Types of Foundation Systems.** The following systems have been successfully used on past projects. Other foundation systems may also be acceptable and shall be considered by the Designer of Record.
- 4.2.1. *Footings and Mats*
- 4.2.1.1. Concrete footings and mats shall be designed and installed in accordance with NFPA 5000, Chapter 36, Section 4, and in accordance with the geotechnical report.
- 4.2.2. *Drilled Piers, Caissons, and Auger Cast Piles*
- 4.2.2.1. Drilled piers and caissons shall not be longer than 30 times their diameter.
- 4.2.2.2. Drilled piers, caissons, and auger cast piles shall be designed and installed in accordance with NFPA 5000, Chapter 36, Section 5, and in accordance with the recommendations of the geotechnical report.
- 4.2.3. *Driven Piles*
- 4.2.3.1. Driven piles, constructed of steel, concrete-filled steel, precast concrete, or wood, shall be designed and installed in accordance with NFPA 5000, Chapter 36, Section 5, and in accordance with the geotechnical report.

**9040-1. General**

- 1.1. Floor systems shall be coordinated with architectural, mechanical, plumbing, electrical, and other trades to provide sufficient space between floors for routing of utilities. Consider the structural depth of the floor system and routing of utilities through structural elements as necessary.
- 1.2. Floor systems shall achieve the fire rating as required by code.
- 1.3. Concrete slabs on metal deck shall have a minimum thickness of 3 inches. Concrete topping on precast floor members shall have a minimum thickness of 2 inches. Concrete may be normal weight or lightweight. Lightweight concrete density shall range from 90 pounds per cubic foot to 115 pounds per cubic foot.
- 1.4. Conduit may be run inside concrete slabs, in accordance with diameter and spacing limits as specified in ACI 318, Chapter 6, and as limited by Steel Deck Institute requirements.
- 1.5. Floor flatness shall be specified in accordance with ACI 302.1R.

**9040-2. Performance Criteria****2.1. Vertical Deflection**

- 2.1.1. The maximum deflection for interior floor framing elements shall be in accordance with NFPA 5000.
- 2.1.2. The maximum deflection for spandrel beams and girders shall be in accordance with AISC Design Guide 3.

**2.2. Vibration**

- 2.2.1. Floor systems shall be designed to minimize vibration. For steel beam and/or steel joist framed floors, design for vibration shall be in accordance with AISC Design Guide 11. Design for walking excitation, according to AISC Design Guide 11 Chapter 4, with a maximum acceleration of 0.5 percent of gravity. For concrete floors, design for vibration shall be in accordance with ATC Design Guide 1.

**2.3. Acoustics**

- 2.3.1. Acoustical transmissions through floors due to occupants or equipment shall be minimized. Floors of mechanical penthouses shall be constructed with a minimum of 4 inches of normal-weight concrete.

**9040-3. Preapproved Structural Systems**

- 3.1. Preapproved structural systems are ranked into two categories. All other factors being equal, Tier 1 systems are preferred over Tier 2 systems, but both are acceptable.



**3.2. Justice Facilities.** The following are preapproved structural systems for above-grade floor construction in Justice Facilities:

- 3.2.1.** Concrete slab on composite metal deck on composite steel beams with headed shear studs welded through the floor deck to the beam flange. (Tier 1)
- 3.2.2.** Concrete slab on metal floor deck on metal joists, supported by steel beams or masonry bearing walls or precast concrete bearing walls. Metal floor deck shall be form deck or composite deck. Metal joists may be composite or noncomposite. (Tier 1)
- 3.2.3.** Concrete topping slab on precast double-tees or precast slabs on precast beams or precast bearing walls or masonry bearing walls. Concrete topping shall have a minimum thickness of 2 inches and shall be normal-weight concrete. Topping thickness may vary to level the floors. (Tier 2)
- 3.2.4.** Cast-in-place concrete slab on cast-in-place columns or masonry or precast bearing walls. The cast-in-place slab may be flat slab, flat plate, or one-way joists, and shall be reinforced with mild steel. Post-tensioned concrete floor systems shall not be used. (Tier 2)

**3.3. Detention Facilities.** The following are preapproved structural systems for above-grade floor construction in detention facilities:

- 3.3.1.** Concrete slab on composite metal deck on composite steel beams with headed shear studs welded through the floor deck to the beam flange. (Tier 1)
- 3.3.2.** Concrete slab on metal floor deck on metal joists supported by steel beams or masonry bearing walls or precast concrete bearing walls. Metal floor deck shall be form deck or composite deck. Metal joists may be composite or noncomposite. (Tier 1)
- 3.3.3.** Concrete topping slab on precast slabs (solid or hollow core) on precast beams or precast bearing walls or masonry bearing walls. Concrete topping shall have a minimum thickness of 2 inches and shall be normal-weight concrete. Topping thickness may vary to level the floors. Precast cells blocks are also preapproved. (Tier 1)
- 3.3.4.** Cast-in-place concrete slab on cast-in-place columns or masonry bearing walls. The cast-in-place slab may be flat slab, flat plate, or one-way joists, and shall be reinforced with mild steel. Post-tensioned concrete floor systems shall not be used. (Tier 2)

**3.4.** Other structural systems for floor construction are not permitted without prior written approval from the BIA.

**9050-1. General Structural Considerations**

- 1.1. Roof framing systems shall be coordinated with architectural, mechanical, plumbing, electrical, and other trades to provide sufficient space for routing of utilities and building services. Consider the structural depth of the roof system and routing of utilities through structural elements as necessary.
- 1.2. Roof systems shall achieve the fire rating as required by the building code.
- 1.3. Steep-slope and low-slope roofs are permitted. The use of steep-slope roofs in areas of substantial snow loading can help to reduce the snow retained on roof surfaces.
- 1.4. Roof overhangs shall be designed for wind uplift. Roof eaves shall be designed for ice dams and icicles along eaves. See ASCE 7.
- 1.5. Both internally drained roofs and externally drained roofs are permitted.
- 1.6. For large areas of metal roof deck that are exposed during construction, consider and accommodate length changes caused by temperature changes.

**9050-2. Performance Criteria****2.1. Vertical Deflection**

- 2.1.1. The maximum deflection for interior roof framing elements shall be in accordance with NFPA 5000.
- 2.1.2. The maximum deflection for spandrel beams and girders shall be in accordance with AISC Design Guide 3.

**2.2. Acoustics**

- 2.2.1. Acoustical transmissions through roofs due to equipment shall be minimized.

**9050-3. Preapproved Structural Systems**

- 3.1. Preapproved structural systems are ranked into two categories. All other factors being equal, Tier 1 systems are preferred over Tier 2 systems, but both are acceptable.
- 3.2. **Justice Facilities.** The following roof framing systems are preapproved for roof construction in justice facilities:
  - 3.2.1. Metal roof deck on metal joists supported by steel beams or masonry or precast concrete bearing walls. Roof deck shall be acoustic where required. (Tier 1)
  - 3.2.2. Pre-cast double-tees or slabs on precast beams or precast or masonry bearing walls. (Tier 2)
- 3.3. **Detention Facilities**
  - 3.3.1. Metal roof deck on metal joists supported by steel beams or masonry or precast concrete bearing walls. Roof deck shall be acoustic where

required. (Tier 1). Metal roof deck shall be heavier gage for security and welded at each flute to supporting members and at 12" oc. maximum at the sheet perimeter.

- 3.3.2.** Pre-cast double-tees or slabs on precast beams or precast or masonry bearing walls. (Tier 1). Precast cell blocks are also approved. (Tier 1)
- 3.4.** Other structural systems for roof construction are not permitted without prior written approval from the BIA.

**9060-1. General**

- 1.1. Lateral load resisting systems shall be coordinated with architectural, mechanical, plumbing, electrical, and other trades to provide sufficient space for routing of utilities and building services.

**9060-2. Performance Criteria****2.1. Strength**

- 2.1.1. Lateral load resisting systems shall be designed and detailed to resist wind loads, seismic effects, and unbalanced soil loads applied to the building structure.

**2.2. Drift**

- 2.2.1. The maximum allowable story drift resulting from wind loads shall be in accordance with AISC Design Guide 3.
- 2.2.2. The maximum allowable story drift resulting from seismic loads shall be as stated in ASCE 7.

**9060-3. Preapproved Structural Systems**

- 3.1. Preapproved structural systems are ranked into two categories. All other factors being equal, Tier 1 systems are preferred over Tier 2 systems, but both are acceptable.
- 3.2. **Justice Facilities.** The following are preapproved lateral load resisting systems in justice facilities:
  - 3.2.1. Reinforced masonry shear walls. (Tier 1)
  - 3.2.2. Precast concrete shear walls. (Tier 1)
  - 3.2.3. Structural steel braced frames or moment frames. (Tier 1)
  - 3.2.4. Reinforced concrete shear walls. (Tier 1)
- 3.3. **Detention Facilities.** The following are preapproved lateral load resisting systems in detention facilities:
  - 3.3.1. Reinforced masonry shear walls. (Tier 1)
  - 3.3.2. Precast concrete shear walls. (Tier 1)
  - 3.3.3. Structural steel braced frames or moment frames. (Tier 1)
  - 3.3.4. Reinforced concrete shear walls. (Tier 1)
- 3.4. Other types of lateral load resisting systems are not permitted without prior written approval from the BIA.

**9070-1. General****1.1. Columns**

- 1.1.1. Interior and exterior column locations and sizes shall be coordinated among all design disciplines.
- 1.1.2. Steel columns, cast-in-place concrete columns, precast concrete columns, or masonry columns are permitted for use.
- 1.1.3. Minimum forces for steel column anchorage to foundations shall be in accordance with OSHA 1926 – Subpart R.

**1.2. Walls**

- 1.2.1. Either bearing or nonbearing walls may be used. Bearing walls can be a more efficient use of material because they serve multiple purposes, carrying gravity loads and lateral loads as well as serving as walls for architectural purposes. The use of bearing walls, however, may diminish flexibility for future modifications, because modifications affect gravity and lateral load carry capacities.

**1.3. Stairs and Elevators**

- 1.3.1. Structural framing around stair and elevator shafts may be used to carry gravity and lateral loads, either with bearing/shear walls or steel-braced frames.
- 1.3.2. Provide framing to support elevator guide rails.
- 1.3.3. If stairs are specified with a performance specification, clearly define how and where the stair can be supported from the building structure.

**9080-1. General**

- 1.1. Structural wall systems shall be coordinated with architectural, mechanical, plumbing, electrical, and other disciplines.

**9080-2. Performance Criteria****2.1. Deflection Out-of-Plane Due to Wind Loads**

- 2.1.1. The maximum deflection of metal stud walls shall conform to NFPA 5000; Table 35.1.2.8.1.1, except the deflection under the code-specified wind load for gypsum board walls shall be 1/360th of the length of the element.
- 2.1.2. The maximum deflection of metal stud walls supporting masonry, Portland cement stucco, or other brittle materials shall be 1/600th of the length of the element.

**2.2. Acoustics**

- 2.2.1. Acoustical transmissions through walls due to occupants or equipment shall be minimized. Refer to architectural sections for specific requirements.

**2.3. Security**

- 2.3.1. Structural wall systems shall satisfy the security requirements for inmate retention and external criminal acts such as blast loading, small arms, and vehicle ramming.

**9080-3. Pre-approved Exterior Wall Systems**

- 3.1. Pre-approved structural exterior wall systems are ranked into two categories. All other factors being equal, Tier 1 systems are preferred over Tier 2 systems, but both are acceptable.
- 3.2. **Justice Facilities.** The following are pre-approved exterior wall systems in justice facilities:
  - 3.2.1. Non-load-bearing metal stud walls composed of galvanized metal “C” studs with pre-punched webs. Studs are attached to the frame with proprietary slip clips. Studs shall be spaced at 16 inches on center, maximum. Metal stud galvanizing shall be G60, minimum, in arid climates and G90, minimum, in humid climates. Slip clips shall not allow more than 1/8 inch out-of-plane deflection under lateral wind loads. (Tier 1)
  - 3.2.2. Load-bearing masonry walls composed of lightweight or normal-weight concrete masonry or clay masonry, partially or fully grouted and reinforced with steel rebar. Thickness may range from 6 inches up to 12 inches. Walls may have pilasters as required to support heavy point loads. (Tier 1)

- 3.2.3. Load-bearing pre-cast concrete wall panels composed of insulated sandwich panels or non-insulated panels made from normal-weight or lightweight concrete. Thickness ranges from 6 inches to greater than 12 inches. Sandwich panels have a face of concrete, rigid insulation, and a backing of concrete. Panels may be site cast or plant cast. (Tier 1)
- 3.3. Detention Facilities. The following are pre-approved exterior wall systems in detention facilities:
  - 3.3.1. Load-bearing masonry walls composed of normal-weight concrete masonry or clay masonry, partially or fully grouted and reinforced with steel rebar. Normal weight concrete masonry units shall be used. Masonry cells shall be reinforced with a #4 bar or larger at 8" o.c. maximum. Masonry walls shall be solid grouted. Thickness may range from 6 inches up to 12 inches. Walls may have pilasters as required to support heavy point loads. (Tier 1)
  - 3.3.2. Load-bearing pre-cast wall panels composed of insulated sandwich panels or non-insulated panels with normal-weight or lightweight concrete. Thickness ranges from 6 inches to greater than 12 inches. Sandwich panels have a face of concrete, rigid insulation, and a backing of concrete. Panels may be site cast or plant cast. (Tier 1)
- 3.4. Other types of exterior wall systems are not permitted without prior approval from the BIA.

#### 9080-4. Pre-approved Interior Structural Wall Systems

- 4.1. Pre-approved interior wall structural systems are ranked into two categories. All other factors being equal, Tier 1 systems are preferred over Tier 2 systems, but both are acceptable.
- 4.2. **Justice Facilities.** The following are pre-approved interior structural wall systems in justice facilities:
  - 4.2.1. Load-bearing masonry walls composed of lightweight or normal-weight concrete masonry or clay masonry, partially or fully grouted and reinforced with steel rebar. Thickness may range from 6 inches to 12 inches. Walls may have pilasters as required to support heavy point loads. (Tier 1)
  - 4.2.2. Load-bearing pre-cast wall panels composed of reinforced normal-weight or lightweight concrete. Thickness may range from 6 inches to 12 inches. Wall panels may be site cast or plant cast. (Tier 1)
- 4.3. Detention Facilities. The following are pre-approved interior structural wall systems in detention facilities:
  - 4.3.1. Load-bearing masonry walls composed of concrete masonry or clay masonry, partially or fully grouted and reinforced with steel rebar. Normal weight concrete masonry units shall be used. Masonry cells shall be reinforced with a #4 bar or larger at 8" o.c. maximum. Masonry walls

shall be solid grouted. Thickness may range from 6 inches to 12 inches.  
Walls may have pilasters as required to support heavy point loads. (Tier 1)

- 4.3.2.** Load-bearing pre-cast wall panels composed of reinforced normal-weight or lightweight concrete. Thickness may range from 6 inches to 12 inches. Wall panels may be site cast or plant cast. (Tier 1)
- 4.4.** Other types of interior structural wall systems are not permitted without prior approval from the BIA.



**9090-1. General**

1.1. Appurtenances to building structures include, but are not limited to:

- Canopies
- Sunscreens
- Covered walkways
- Ground-supported screen walls

1.2. Consider the following:

- 1.2.1. Snow loads may be significantly increased due to drifting from higher roofs onto lower surfaces.
- 1.2.2. Appurtenances are often open and are subjected to special wind load effects.
- 1.2.3. Appurtenances are often exposed to weather. Provide protection from corrosion. See Section 9030 for more information.
- 1.2.4. Appurtenances are often composed of multiple materials, including steel, stainless steel, galvanized steel, and aluminum. Consider the effects of galvanic corrosion due to dissimilar metals.

**10000-1. Introduction**

- 1.1. This chapter shall be used as a guideline in the development of the HVAC, plumbing, and temperature controls/energy management design documents for all new BIA justice/detention facilities. The design shall be in conformance with these guidelines unless exceptions to them are granted by the BIA.
- 1.2. Refer to Chapter 1, “General Information,” and Chapter 2, “Presentation of Data,” for required documents, drawing and specifications formats, and other design and submittal requirements not discussed in this chapter.
- 1.3. Additional design and submittal requirements may apply for projects with unusual or highly technical criteria.
- 1.4. As applicable, the Designer of Record shall incorporate the sustainability strategies identified in Chapter 3, “LEED Goals and Guidelines.”
- 1.5. The guidelines in this chapter should be used in conjunction with those in the other chapters in this handbook, and the Designer of Record should coordinate with the other project consultants to be sure all aspects of the justice/detention facilities are effective and compatible.
- 1.6. All design features must be weighed carefully for their initial cost, long-term maintenance cost and needs, durability, and their impact on the environment.

**10000-2. Design Team Goals**

- 2.1. The design team shall accomplish the following:
  - Design all justice/detention facilities to meet LEED Silver certification requirements. (Refer to Chapter 3.)
  - Meet energy and environmental performance criteria.
  - Optimize design choices through simulations, models, and other design tools.
  - Employ life-cycle cost analysis (LCCA) in all decision making.
  - Design all systems for ease of maintenance and operation.
  - Provide clear complete specifications for the demonstration and training of the operation and maintenance staff.

**10000-3. Documents**

- 3.1. Specific design submittal requirements in this chapter supplement the requirements in Chapter 2. All documents, including drawings, specifications, calculations, and analyses shall be submitted in phases in accordance with Chapter 2.

**3.2. Specifications**

- 3.2.1.** Describe each system and all equipment to the greatest extent possible. Equipment shall be selected from a minimum of three manufacturers who meet specified requirements.

**3.3. Drawings**

- 3.3.1.** Provide complete plans, elevations, and sections at a minimum scale of 1/8 inch equals 1 foot for all HVAC and plumbing systems. HVAC and plumbing shall not be combined on the same drawings.
- 3.3.2.** Do not superimpose mechanical equipment, ductwork, and piping on architectural plans.
- 3.3.3.** Provide plan(s) and elevations(s) of all mechanical equipment rooms that are used for primary equipment such as boilers, chillers, and air handlers. A scale of not less than 1/4 inch equals 1 foot shall be used.
- 3.3.4.** Provide details as needed to illustrate or to clarify equipment installation. Details shall include piping diagrams for pumps, coils, chillers, and boilers.
- 3.3.5.** Provide complete legends for plumbing and for HVAC systems.
- 3.3.6.** Control drawings shall be consolidated on one or more sheets. The drawings shall include control diagrams and the location of all sensors, controlled devices, and direct digital controllers.
- 3.3.7.** Equipment schedules shall, as a minimum, include all equipment listed in this mechanical guide. All capacities, power requirements (horsepower, phase, voltage, frequency, speeds), sizes, and special requirements shall be shown. Schedules shall be consolidated on one or more sheets.
- 3.3.8.** Schematic flow diagrams shall be provided for each HVAC and piping system. Flow diagrams shall indicate flows, temperatures, and pressures, as appropriate. The diagrams shall indicate all devices, including valves (balancing and shutoff), strainers, check valves, temperature/flow indicators, control valves, drain valves, expansion tanks, etc. These diagrams may be combined with control drawings.
- 3.3.9.** Plumbing plans shall include roof drainage systems and waste, vent, and water piping, including fixtures, cleanouts, wall hydrants, isolation valves, and service entrance location.
- 3.3.10.** Kitchens, toilet areas, and shower areas, plans and sections shall use a minimum scale of 1/4 inch equals 1 foot.
- 3.3.11.** Provide isometric diagrams for waste/vent and water piping systems as required by the Uniform Plumbing Code (UPC) and local authorities.

**3.4. Energy Budget Analysis**

- 3.4.1.** The energy budget (kBtu/SF/yr) shall be established early in the design process. It shall be determined through preliminary building energy modeling, which begins in the schematic design process.
- 3.4.2.** Refer to Section 10010 for minimum requirements.

**3.5. Design Analysis**

- 3.5.1.** Refer to Section 10010, “Mechanical Systems Selection Criteria,” for energy simulation evaluations, evaluation tools, and energy goals/concepts.
- 3.5.2.** Justification for system and equipment selections shall be based on energy consumption reduction from an established baseline, in accordance with ASHRAE 90.1; from an LCCA on selected items; and from an evaluation of critical issues such as system flexibility, simplicity, and ease of maintenance/operation. To evaluate such items, a matrix comparing life-cycle costs with other selected criteria shall be developed. A narrative that discusses evaluated options, conclusions, and recommendations along with supportive calculations shall also be submitted.
- 3.5.3.** Systems/equipment requiring a design analysis shall include:
- Building envelope and orientation optimization
  - Daylighting and lighting system optimization
  - HVAC system selection optimization
  - Optimization of system design parameters that affect operating efficiencies, such as part load efficiencies
  - Selection of optimum fuels
  - Dedicated outside air systems with heat recovery
  - Cooling towers compared to air-cooled condensers
  - Variable speed pumping
  - Solar domestic hot water systems
  - Geo-exchange systems
  - Other systems identified in this chapter requiring a design analysis

**3.6. Required Design Calculations**

- 3.6.1.** Heating/cooling loads.
- 3.6.2.** Design pressure drop and velocities for ductwork, hydronic piping, and gas piping.
- 3.6.3.** Building utilities pipe sizing.

- 3.6.4. Plumbing fixture counts.
- 3.6.5. Piping stress calculations for hot water systems (operating temperatures over 210°F).
- 3.6.6. Seismic calculations demonstrating design category for building and mechanical components.
- 3.6.7. Water treatment tests and evaluations.
- 3.6.8. Acoustical evaluations and recommendations for rotating equipment and distribution systems.
- 3.6.9. Other calculations required in this guide and by identified codes.

#### 10000-4. Quality Control

- 4.1. Quality control review shall include, but not be limited to, the following:
  - 4.1.1. Perform a complete, independent review for errors, omissions, and coordination within and between disciplines.
  - 4.1.2. Verify that equipment locations are indicated.
  - 4.1.3. Verify that all equipment that is indicated on schedules, one-line diagrams, and specifications is indicated on the plans.
  - 4.1.4. Verify that all equipment is properly identified.
  - 4.1.5. Verify that ducts or piping are not routed over electrical equipment.
  - 4.1.6. Verify that power is supplied to all equipment.
  - 4.1.7. Coordinate data and requirements with the electrical design.
  - 4.1.8. Verify that all motors and power-consuming equipment are shown on the plans and schedules.
  - 4.1.9. Verify that the legend matches the symbols used on the plans.
  - 4.1.10. Verify that the design meets the scope of work and complies with the design guideline requirements.
  - 4.1.11. Verify that building utilities are coordinated with outside utilities.

#### 10000-5. Building Types

- 5.1. Designs shall be modified as appropriate for code compliance and best practices for the building type. Possible building types and special areas include:
  - Tribal courts
  - Law enforcement
  - Tier 1 Holding
  - Kitchens

**10000-6. Local Parts Availability**

- 6.1.** Verify that local availability of spare parts, replacement parts, and service technicians for equipment is specified.
- 6.2.** If equipment is not locally available, determine the response time for obtaining it and verify with the BIA that the time is acceptable.

**10000-7. Warranty**

- 7.1.** Standard warranty shall be 1 year from successful startup.
- 7.2.** Additional or extended warranties are noted in other sections of this chapter.
- 7.3.** As a minimum, warranties for refrigerant compressors and domestic hot water heaters shall be 5 years and shall include parts, labor, and refrigerant.

**10010-1. Systems Evaluation**

- 1.1. This section presents guidelines for mechanical ventilation, heating, and cooling systems, along with the goals the BIA has established for their justice and detention facilities.
- 1.2. **Energy Simulation Evaluation.** The following standards and programs are acceptable for use in generating a detailed evaluation of proposed heating, ventilating, and air-conditioning systems. Unless noted otherwise the latest version of the following shall be used.
  - 1.2.1. ***ASHRAE 90.1.*** This standard sets criteria for building envelopes, mechanical and electrical systems.
  - 1.2.2. ***Building Loads Analysis and System Thermodynamics (BLAST).*** This program has been developed by the United States Department of Defense and is available through the University of Illinois, [www.bso.uiuc.edu](http://www.bso.uiuc.edu).
  - 1.2.3. ***Carrier's Hourly Analysis Program (HAP).*** This is a software system network. Use of this program to generate the building load data will be considered, but must be submitted for approval prior to use.
  - 1.2.4. ***DOE-2.*** This program analyzes the energy efficiency of buildings using an hourly weather file and simulating energy performance during a typical year. Contact Lawrence Berkeley National Laboratory, [www.lbl.gov](http://www.lbl.gov). Visual DOE, Power DOE, and eQuest are available user graphic interfaces for DOE-2.
  - 1.2.5. ***Energy Plus.*** This program is being developed by the U.S. Department of Energy and is a successor to both DOE-2 and BLAST. Contact Lawrence Berkeley National Laboratory, [www.lbl.gov](http://www.lbl.gov).
  - 1.2.6. ***Trane Trace 700.*** This program has been developed by the Trane Company and is available through their Customer Direct Service (CDS).
- 1.3. **Energy Goals and Concepts**
  - 1.3.1. All justice and detention facilities shall be designed to obtain a LEED Silver certification.
  - 1.3.2. The ASHRAE 90.1(2004) energy standards and requirements **shall be exceeded by at least 30 percent or shall be less than 75,000 Btu's per square foot per year**, whichever is less.
  - 1.3.3. Items identified for life-cycle cost analysis (LCCA) shall be evaluated in accordance with the Code of Federal Regulations Title 10: Energy.
  - 1.3.4. The following are high-performance building concepts that shall be included in each design:
    - Individual temperature controls for significant spaces.
    - Continuous measurement of all energy sources.

- Direct digital control (DDC) and energy management systems. Use local area networks and the Internet for remote control and monitoring.
- Occupancy sensors to control HVAC and lighting systems.
- Carbon dioxide sensors to control ventilation air quantities.
- NEMA Premium-efficiency motors.

**1.3.5.** The following shall be considered in each design through an LCCA evaluation:

- Dedicated outside air systems with heat recovery.
- Domestic hot water (DHW) solar preheaters.
- Variable-frequency drives on pumps and fans that are 5 horsepower and larger when systems need variable quantities.
- Renewable energy sources such as photovoltaic, wind, and geothermal exchange.



### General

The mechanical design for justice and detention facilities shall comply with all applicable current codes, standards, and laws. For a more general list of codes and standards that apply to BIA justice and detention facilities, refer to Chapter 1, “General Information.” During design, report any required deviations from codes and standards to the Contracting Officer.

Where two codes, standards, or laws are applicable to the topic under review, use the more conservative or more stringent. Consult with the BIA Office of Facilities Management and Construction (OFMC) to resolve any questions or conflicts regarding application of codes and standards.

### Applicable Codes and Standards

The design criteria shall comply with the guidelines published by or contained in the latest edition(unless noted otherwise) of the following:

#### 2.0.1. *Air-Conditioning and Refrigeration Institute (ARI)*

- Standard 210-240 – Performance Rating of Unitary Air-Conditioning & Air-Source Heat Pump Equipment
- Standard 310/380 – Standard for Packaged Terminal Air-Conditioners and Heat Pumps (CSA-C744-04)
- Standard 320 – Water-Source Heat Pumps
- Standard 410 – Forced-Circulation Air-Cooling and Air-Heating Coils

#### 2.0.2. *American National Standards Institute (ANSI)*

- B31.1 Power Piping
- B31.9 Building Services Piping

#### 2.0.3. *American Society of Heating, Refrigerating, and Air-Conditioning Engineers (ASHRAE)*

- Latest edition of the following handbooks: *Fundamentals, HVAC Applications, HVAC Systems and Equipment, and Refrigeration*
- Standard 15 Safety Standard for Refrigeration Systems
- Standard 55 Thermal Environmental Conditions for Human Occupancy
- Standard 62.1 Ventilation for Acceptable Indoor Air Quality
- Standard 90.1 Energy Standard for Buildings Except Low-Rise Residential Buildings
- Standard 100 Energy Conservation in Existing Buildings

- Standard 135 BACnet – A Data Communication Protocol for Building Automation and Control Networks

#### 2.0.4. *American Society of Mechanical Engineers (ASME)*

- CSD-1 – Controls and Safety Devices for Automatically Fired Boilers
- Section IV – Rules for Construction of Heating Boilers
- Section VIII – Rules for Construction of Pressure Vessels Division 1

#### 2.0.5. *American Water Works Association (AWWA)*

|                                      |  |
|--------------------------------------|--|
| AWWA-01                              | Standard Methods for the Examination of Water and Wastewater                                 |
| AWWA B300                            | Hypochlorites  |
| AWWA B301                            | Liquid Chlorine  |
| AWWA ANSI /<br>AWWA C104 /<br>A21.4  | Cement-Mortar Lining for Ductile-Iron Pipe and Fittings for Water                            |
| AWWA ANSI /<br>AWWA C110 /<br>A21.10 | Ductile-Iron and Gray-Iron Fittings for Water  |
| AWWA ANSI /<br>AWWA C111 /<br>A21.11 | Rubber-Gasket Joints for Ductile-Iron Pressure Pipe and Fittings                             |
| AWWA ANSI /<br>AWWA C151 /<br>A21.51 | Ductile-Iron Pipe, Centrifugally Cast, for Water or Other Liquids                            |
| AWWA C203                            | Coal-Tar Protective Coatings & Linings for Steel Water Pipelines, Enamel & Tape, Hot-Applied |
| AWWA M20                             | Water Chlorination/Chloramination Practices and Principles                                   |

**2.0.6. Code of Federal Regulations (CFR)**

- Title 10, Chapter II, Part 433 Energy Efficiency Standards for the Design and Construction of New Federal Commercial and Multi-Family High-Rise Residential Buildings
- Title 10, Chapter II, Part 434 Energy Code for New Federal Commercial and Multi-Family High Rise Residential Buildings
- Title 10, Chapter II, Part 436 Federal Energy Management and Planning Programs

**2.0.7. International Association of Plumbing and Mechanical Officials (IAPMO)**

- Uniform Mechanical Code (UMC)
- Uniform Plumbing Code (UPC)

**2.0.8. National Fire Protection Association (NFPA)**

- NFPA 5000 Building Construction and Safety Code
- NFPA 90A Standard for the Installation of Air-Conditioning and Ventilating Systems
- NFPA 92A Standard for Smoke Control Systems Utilizing Barriers and Pressure Differences
- NFPA 101 Life Safety Code

**2.0.9. National Institute of Standards and Technology (NIST)**

- Handbook 135 *Life-Cycle Costing Manual for the Federal Energy Management Program.*
- Public Law 109-58 Energy Policy Act of 2005

**2.0.10. Sheet Metal and Air Conditioning Contractors' National Association (SMACNA)**

- Latest edition *HVAC Duct Construction Standards – Metal and Flexible*
- Latest edition *HVAC Systems – Testing, Adjusting & Balancing*

**2.0.11. *U.S. Green Building Council – Leadership in Energy Performance and Environment Design (LEED)***

- *LEED Reference Guide for Green Building Design and Construction 2009 Edition.*
- LEED 2009 rating system for New Construction.

**2.0.12. *National Institute of Corrections Guidelines for Suicide Prevention (latest version).***

**2.0.13. *American Correctional Association (ACA). Refer to appropriate standards manual***



**10030-1. General**

- 1.1. Use the ASHRAE heating, ventilation, and air-conditioning (HVAC) handbooks to develop the HVAC design.

**10030-2. Outdoor Air Design Values**

- 2.1. Summer and winter outside air design values shall be derived from standard ASHRAE-compiled weather data located in the latest edition of the *ASHRAE Handbook – Fundamentals*. Use the 99.6% design values for heating design dry-bulb, the 1% design values for cooling design dry-bulb, and the mean coincidental wet-bulb temperatures.

**10030-3. Indoor Air Design Values**

- 3.1. The occupied temperatures used for building load calculations shall be within the range denoted for summer and winter values. Summer design values shall range from 75°F to 78°F. Winter design values shall range from 70°F to 72°F. The relative humidity of the building spaces shall be targeted at 50 percent or less. Humidification shall not be added to spaces unless specifically required by specialized equipment.
- 3.2. Night setback temperatures shall be used for all systems serving spaces which are unoccupied. Winter setback temperatures shall be 60°F unless calculations show a systems recovery time warrants less set back.

**10030-4. Outdoor Air Ventilation Requirements**

- 4.1. Outdoor ventilation rates shall be calculated for each occupied space and shall conform to the requirements of ASHRAE 62.1.
- 4.2. Each system shall be evaluated for the use of a 100 percent air economizer cycle to cool the building when outside air conditions are conducive to cooling. ASHRAE 62.1 shall be used to determine whether enthalpy or sensible controlled economizers shall be used.
- 4.3. Energy recovery systems shall be considered in the ventilation design for reducing energy consumption.
- 4.4. Demand-controlled ventilation (DCV) systems shall be considered to control the quantity of outside air. Carbon dioxide sensors shall be located in the most densely occupied spaces where an air handling system is supplying air. Levels shall be monitored through the direct digital control (DDC) system to verify that the system is maintaining a carbon dioxide level in the occupied rooms relative to the outdoors of no more than 400 plus or minus 50 parts per million (ppm).

**10030-5. Designing Systems at Elevations Above Sea Level**

- 5.1. Equipment and distribution systems are typically rated at sea level conditions. At elevations above sea level, equipment and systems shall be sized to compensate for changes in air density.

### 10030-6. Selection of HVAC Systems

6.1. In selecting the HVAC systems, evaluate the environmental criteria of the facility. Combinations of systems and central equipment shall be considered. A computerized energy analysis of at least three systems will be required for each facility at the schematic design stage, unless this requirement is specifically excluded by the BIA.

#### 6.2. Equipment Selection

6.2.1. To ensure that the design performs well, it is important to integrate the HVAC systems with the building envelope/orientation and daylighting/lighting systems. The design strategies shall be appropriate for the different climatic zones of the project.

6.2.2. When selecting systems and equipment, take into account part-load operation and part-load efficiency. The choice of the optimal system type for a specific facility shall be based on the following factors:

- Life-cycle cost (includes first cost, maintenance cost, and operations cost)
- Maintainability
- Simplicity of operation
- Durability
- Reliability
- Acceptable sound levels
- Space requirements
- Water conservation
- Environmental control
- Indoor air quality
- Cooling/heating effectiveness

6.2.3. HVAC systems to be considered for life-cycle cost analysis (LCCA) justification are:

- Packaged air handling units with chilled water cooling and with variable air volume (VAV) terminal hot water heating
- Same system as above, except with integral direct expansion (DX) refrigeration/air condensate system
- Ground source heat pump systems
- Ground source hybrid heat pump systems
- Water source heat pump systems with condensing boilers and fluid coolers

- 6.2.4. Alternative HVAC systems that are not listed above shall be permitted, provided they prove beneficial relative to energy analysis, life-cycle cost analysis, and maintainability. Alternative systems shall be evaluated against the preapproved systems described in this handbook.
- 6.2.5. Evaporative cooling systems for kitchen makeup air are the preferred systems. Verify that the climatic area is conducive to evaporative cooling.
- 6.2.6. Large assembly spaces(>25 people/1000sf) shall be designed with dedicated air handling units or zoning to accommodate high ventilation loads. A carbon dioxide monitor/control system shall be used.

### **6.3. Year-Round Cooling Requirements**

- 6.3.1. If an air-conditioning system serves areas that have high internal heat gains, such as electronic equipment areas (e.g., telecommunications rooms), consider possible year-round cooling requirements and design the system accordingly. This will include provisions for low ambient operation of air-cooled condensers. Provide for reheating of supply air where justified. For environmental considerations pertaining to telecommunications rooms, refer to Section 13030.

## **10030-7. Air Systems**

### **7.1. Air Handling Units**

- 7.1.1. Locate air handling units (AHUs) strategically throughout the building for good air distribution and to facilitate partial building operation. Desirable locations are inside the building near the building's center and at an outside, accessible wall location. AHUs shall be located in mechanical rooms, mezzanines, or in rooftop penthouses. Vibration isolators shall be provided on each unit and care taken to not locate AHUs close to noise sensitive areas such as court rooms, etc. Non-enclosed rooftop units are not permitted.
- 7.1.2. As a minimum, each AHU shall include the following components: a supply/return air fan(s), cooling coil, preheating coil, minimum efficiency reporting value (MERV) 8 filters, a mixing box, DDC stand-alone controls, an access section, an economizer, and variable frequency drive(s) (VFD). The maximum capacity for each system shall be limited to 30,000 cubic feet per minute.
- 7.1.3. The AHU shall be designed to deliver a minimum of 55°F supply air to the terminal units. For areas with morning warm-up, heating coils shall be sized to deliver a maximum of 90°F supply air to the terminal units.
- 7.1.4. To vary the air volume available to the system, each variable air volume AHU shall use a VFD on both supply and return/relief fans. Smaller capacity units under 5 HP will not need relief fan VFDs.
- 7.1.5. Energy recovery methods shall be evaluated to temper the outside air.



- 7.1.6.** Air handler system zoning shall conform to LEED-NC Indoor Environmental Quality credit requirements for controllability of systems and thermal comfort. Zoning plans shall be developed and shall be submitted with the Design Development package. General administrative areas (up to 500 square feet), individual offices/support rooms (more than 300 square feet), each conference room shall be single zones.
- 7.1.7.** Packaged AHUs with integral DX refrigeration systems shall use scroll compressors. Multiple compressors shall be used to allow operation down to 25 percent of design without using hot gas bypass. There shall be a minimum of two separate DX circuits for each AHU which has two or more compressors.

**7.2. Ductwork Distribution Systems**

- 7.2.1.** Ductwork shall be designed in accordance with applicable SMACNA standards and ASHRAE recommendations. All supply and return air (in unconditioned space) shall be insulated in accordance with ARCOM MASTERSPEC 23 07 00 HVAC Insulation.

**7.2.2. *Variable Air Volume Heating Terminal Units***

- 7.2.2.1.** Terminal units shall be located above the ceiling and shall control the flow of air to the space based on a space temperature sensor. Terminal units should be located in an accessible location above the ceiling (where ceilings exist) to allow for maintenance.
- 7.2.2.2.** On a rise in space temperature, the damper in the terminal unit will open and allow air from the duct system into the space. As the space temperature falls, the damper will close to a minimum predetermined position before heating (ASHRAE 90.1). The minimum position shall be set to maintain the required ventilation rate in the space. On a continued fall in space temperature, the heating coil control valve at the terminal unit shall be opened to maintain the space set point.
- 7.2.2.3.** If the terminal unit described above when in compliance with ASHRAE 90.1 fails to achieve the necessary space heating, a parallel fan-powered box system shall be used in conjunction with the variable air volume terminal. The fan-powered box shall return ceiling plenum air through a hydronic heating coil to the space.

**7.2.3. *Supply Air Ductwork***

- 7.2.3.1.** Air will be distributed to terminal air devices located throughout the space via a ductwork system. The maximum air velocity in this part of the ductwork system shall be less than 1,200 feet per minute.
- 7.2.3.2.** Supply-air ductwork connections to ceiling-mounted air devices may be completed with flexible ductwork. Duct lengths shall not exceed 10 feet.

**7.2.3.3.** Air devices shall be ceiling mounted wherever possible. If spaces do not include ceilings, the air devices should be wall or duct mounted and shall be out of the reach of detained personnel.

**7.2.3.4.** Each duct leading to an air device shall include a manual volume damper to balance the system. Dampers on air devices shall not be used for balancing.

#### **7.2.4. *Return/Relief Air Systems***

**7.2.4.1.** Return air may be ducted to the AHUs or transferred by return air plenums as allowed by codes.

**7.2.4.2.** All AHUs shall have a return/relief air fan for maintaining positive building pressurization.

**7.2.4.3.** The return/relief air fan shall be variable volume and sized to maintain under all operating conditions a slight positive pressure in the general spaces. Building pressure shall be maintained by controlling the relief/exhaust damper to maintain a set building pressure with respect to the outdoors.

#### **7.2.5. *Electric Resistance Heating***

**7.2.5.1.** Electric resistance heating for comfort applications is not allowed, except for unusual situations and where approval is obtained from the BIA. Supplemental resistance electric heaters can be used with water source heat pump systems.

**7.2.6.** Ductwork shall not pass through a telecommunications room or an electrical room.

### **7.3. Exhaust Air Systems**

**7.3.1.** General exhaust systems shall be provided to exhaust restrooms, electrical rooms, mechanical rooms, custodial closets, and storage rooms. Exhaust discharge shall be located downwind of air handler intakes and operable windows.

**7.3.2.** Where LCCA justified exhaust systems shall be part of the dedicated outside air system with heat exchange. Heat recovery with a minimum effectiveness of 50% shall be utilized unless a LCCA shows a more effective exchange is more favorable. The engineer shall verify if any non-lethal gas agents may be utilized before selecting the use of heat wheel type energy recovery units.

**7.3.3.** Roof-mounted fans are not recommended but may be used on low-profile roofs.

**7.3.4.** Interior fans shall be used for general building exhaust. Fans shall not be located over sound-sensitive areas such as court rooms and conference rooms. Fans shall be installed within 2 feet of an accessible ceiling (where ceilings exist) to allow for maintenance.

### **7.3.5. *Special Exhaust Systems***

- 7.3.5.1. Kitchen canopy systems shall be provided over kitchen cooking equipment where required by applicable codes. Kitchen canopies shall include exhaust and makeup air as required by applicable codes. The kitchen ventilation and exhaust system shall be designed in accordance with the latest edition of the *ASHRAE Handbook – HVAC Applications* and shall comply with NFPA 96 Standard for Ventilation Control and Fire Protection of Commercial Cooking Operations.
- 7.3.5.2. Dishwasher exhaust shall be designed to meet the requirements set forth by the dishwasher manufacturer. Direct-connected system or overhead exhaust hood arrangements shall be used as appropriate.
- 7.3.5.3. Smoke control systems where required shall be installed in accordance with NFPA 92A utilizing barriers and pressurization differences.

### **7.3.6. *Locker Room Exhaust Systems and Equipment Rooms Ventilation***

- 7.3.6.1. Locker room spaces shall be exhausted independently from the building general exhaust systems. The quantity of exhaust shall be designed to meet the minimum code requirements, but shall not be less than 0.5 cubic feet per minute per square foot of floor area.
- 7.3.6.2. The exhaust shall be grouped from specific spaces, such as men's locker rooms or women's locker rooms. Energy recovery systems shall be evaluated for use in preconditioning the supply air.
- 7.3.6.3. In equipment rooms, mechanical ventilation shall be provided to limit air temperature rise to roughly 10°F when the room is unoccupied. When appropriate, provide a wall-mounted supply fan and exhaust fan with motorized dampers. Size ventilation equipment for the greater of a 10°F rise for summer or an air change rate of 10 per hour for winter operations.

## **7.4. Heat Pump Systems**

- 7.4.1. If the facility requires simultaneous heating and cooling and has a minimum cooling capacity of 35 tons then the use of a heat pump system shall be evaluated.
- 7.4.2. There are three types of heat pumps systems to be evaluated. They are:
  - 7.4.2.1. Ground source heat pump systems - the ground source heat pump system uses the earth for heat rejection and absorption.
  - 7.4.2.2. Ground source hybrid heat pump systems - the ground source hybrid heat pump system optimizes the geothermal field for the smaller of the heating or cooling seasonal demand. Either supplementary

heating or cooling is provided by way of a high efficiency condensing boiler or a closed circuit fluid cooler.

- 7.4.2.3.** Water source heat pump systems - the water source heat pump systems use boilers and/or fluid coolers as the energy source and does not use a geothermal field.
- 7.4.3.** For ground source heat pump systems or ground source hybrid heat pump systems the following is necessary:
  - 7.4.3.1.** The evaluation shall be based on the results of a test bore. The test bore shall provide the formation thermal conductivity and diffusivity as well as the deep earth temperature.
  - 7.4.3.2.** High-efficiency heat pumps that use non-CFC and non-HCFC refrigerants shall be selected.
  - 7.4.3.3.** Heat pumps shall be of the extended range type, designed to operate with entering water temperatures in the 32°F to 100°F temperature range.
  - 7.4.3.4.** The geothermal bore field design shall be completed by a professionally registered engineer who is accredited by the International Ground Source Heat Pump Association (IGSHPA). The installation of the bore field piping shall be done by a contractor who is installer accredited by the IGSHPA and who has at least two years of successful installation experience with closed-loop ground heat exchanger systems.
- 7.4.4.** For water source heat pump systems the following is necessary:
  - 7.4.4.1.** High-efficiency heat pumps that use non-CFC and non-HCFC refrigerants shall be selected.
  - 7.4.4.2.** Heat pumps shall be of the normal range type, designed to operate with water temperatures in the 60°F to 90°F temperature range.
  - 7.4.4.3.** The auxiliary heat source shall be 90% efficient condensing boilers. Consideration of the cooling source shall be base on the local climate and selected appropriately. Fluid coolers can work in any climate but other systems may be considered to be more effective.
- 7.4.5.** All heat pump systems shall use nontoxic, biodegradable circulating fluids such as propylene glycol/water.
- 7.4.6.** All heat pumps shall be located strategically throughout the building for good zoning, good air distribution, ease of maintenance, and for good acoustical control. It is preferable vertical heat pumps be used and located in common rooms together. Heat pump systems shall be single zone systems.

**10030-8. Supplemental Heating Systems**

- 8.1. Cabinet unit heaters shall be mounted in the ceiling, where practical, instead of in the walls.
- 8.2. Unit heaters shall be used for supplementary heat in such areas as mechanical rooms, shop areas, and receiving areas.
- 8.3. Fin tube/radiant ceiling panel heating may be used to provide heat for large exterior exposures. Radiant ceiling panels shall not be used where ceiling heights exceed 12 feet.
- 8.4. Spot heating sources throughout a building may be required and should be evaluated on a case-by-case basis.

**10030-9. Heating Fuel Selection and System Design**

- 9.1. Fuel selection shall be based on availability at the site. Most remote locations will have either natural gas or liquefied petroleum gas (LPG) available. Fuel oil heating shall not be used.
- 9.2. Natural gas distribution systems shall be located away from loading docks, driveways, sidewall air intake louvers, and other locations where physical damage could occur or where venting could enter the building. Construction documents shall show the location of the gas pressure-reducing valve, the gas meter, and the location where the piping enters the building.
- 9.3. LPG storage tanks, vaporizers (when required), and distribution systems shall be designed and installed in accordance with NFPA 58 Liquefied Petroleum Gas Code. The site utility plan shall indicate the tank and distribution system location. Detailed drawings shall show the tank, tank support, piping, relief valves, pressure/volume/temperature gauges, vaporizer (if required), emergency shutoff valves, pressure regulator, and security fencing. The Designer of Record shall determine the storage capacity needed for the site location and shall determine if a vaporizer is required based on load requirements and site temperatures.

**10030-10. Heating and Cooling Plant Criteria**

**10.1. General**

- 10.1.1. Identify a centrally located mechanical room on the building's ground floor and at an outside accessible wall location for the heating and cooling mechanical equipment room.

**10.2. Heating Plant**

- 10.2.1. A minimum of two hot-water boilers with the following characteristics shall be provided:
  - 10.2.1.1. Gas-fired, atmosphere/forced draft, water tube boilers (80 percent minimum efficiency).

- 10.2.1.2.** Condensing boilers where they are LCCA justified (90 percent minimum efficiency).
- 10.2.1.3.** Boilers shall not have aluminum heat exchangers. Propylene glycol systems with inhibitors react with aluminum.
- 10.2.2.** Total heating capacity of the boiler plant shall be approximately 120 percent of the building design load.
- 10.2.3.** Design water supply temperature shall range between 160°F and 200°F. Condensing boilers design supply temperature shall not be greater than 130°F.
- 10.2.4.** Design water temperature drop in the system shall be maintained between 30°F and 40°F.
- 10.2.5.** Heating water distribution loops shall be a reverse return, when feasible.
- 10.2.6.** Steam heating systems in new facilities shall not be used. Specify steam heating only when expanding an existing system and there is no other viable option.
- 10.2.7.** A minimum of two pumps shall be used for water circulation to the building system. It is recommended that the pumps each be sized at 100 percent of the total system flow and pressure. The system shall be designed to maintain the boiler manufacturer's minimum flow requirements.
- 10.2.8.** Antifreeze shall be used in hot water systems in climates with temperatures of +32°F and colder. The design of the heating system shall include a 30 percent solution by volume of inhibited propylene glycol formulated specifically for heating systems. Provide a glycol feed tank and related electric feed pump.
- 10.2.9.** Variable speed pumping above 7-1/2 horsepower shall be evaluated for energy-saving potential on the main heating water pumping systems.
- 10.2.10.** Air shall be removed with automatic separators and vents. Manual vents shall be used at high points within the pipe system. To maintain a constant system pressure, each system shall have a bladder-type expansion tank. System static pressure shall be set at 5 pounds per square inch over building height static pressure.
- 10.2.11.** Each system shall be provided with a manual chemical water treatment system to prevent corrosion and scaling in the heating water system.
- 10.2.12.** A combustion air system for each boiler shall be installed to meet the code. Provide a means for preheating the incoming air or maintaining a minimum temperature of 55°F within the boiler room area.
- 10.2.13.** Gas-firing equipment shall be in accordance with NFPA 54 National Fuel Gas Code.

- 10.2.14. At every point where balancing is required, a flow-measuring device and balancing valve (or a combination thereof) shall be specified and/or shown on the plans. The required length of straight pipe before and after the flow sensor shall be clearly indicated.
- 10.2.15. Water velocity in water piping shall not exceed 6 feet per second and shall be sized for friction loss not greater than 4.5 feet per 100 feet.
- 10.2.16. Multi-duty valves and fittings, such as combination shutoff/check/balancing valves at pump discharges and combination suction diffuser/strainers at pump inlets, shall be used where they can simplify piping and reduce costs. The required length of straight pipe before and after the multi-duty valve shall be shown on the plans.
- 10.2.17. For maintenance purposes, isolation valves shall be provided for isolating each piece of equipment in the system.
- 10.2.18. Thermal expansion must be considered and accounted for in piping. All piping above ambient temperature must be considered, and calculations for lines above 210°F must be included in the design analysis. Allowable stress ranges are given in ANSI B31.9.
- 10.2.19. Anchors and guides shall be provided where required by stress analysis.
- 10.2.20. Valves for shut off service and throttling shall be ball type for piping diameters 2" and less and butterfly type for 2-1/2" and larger. Use of gate and globe valves shall be prohibited.

### 10.3. Cooling Plant

- 10.3.1. Chillers shall be packaged units with either water- or air-cooled condensers. Refrigerated split systems shall not be used.
  - 10.3.1.1. Air-cooled condensers shall be used when facility total tonnage is approximately 200 or less.
  - 10.3.1.2. For tonnages greater than 200, an LCCA comparison between water- and air-cooled condensers shall be completed.
  - 10.3.1.3. Packaged air-cooled units shall be located outdoors and weatherized in climates colder than 32°F.
  - 10.3.1.4. Packaged water-cooled units shall be located indoors with a cooling tower located outdoors and weatherized for locations colder than 32°F.
- 10.3.2. Chiller compressors shall be one of the following types and shall include the following characteristics:
  - 10.3.2.1. Chillers of 130 tons or less shall be scroll or screw (in that order of preference).
  - 10.3.2.2. Chillers of greater than 130 tons shall be screw or centrifugal (in that order of preference).

- 10.3.2.3.** Chillers of more than 30 tons shall operate at less than 25 percent design capacity at the lowest step of loading, without using hot-gas bypass.
- 10.3.2.4.** CFC and HCFC refrigerants shall not be used.
- 10.3.2.5.** Chillers shall meet the noise criteria levels indicated in Section 7040 of this handbook.
- 10.3.3.** Chillers shall be sized at 100 percent of the building coincident peak design load, design water supply temperatures shall range from 42°F to 48°F, and the system design temperature rise shall be maintained between 12°F and 16°F.
- 10.3.4.** Chilled water distribution loops shall be reverse return, where feasible.
- 10.3.5.** With a single chiller, a single pump shall generally be used for water circulation to the building system.
- 10.3.5.1.** The system pump shall be sized at 100 percent of total flow.
- 10.3.5.2.** The chilled water system shall be capable of a minimum 50 percent flow reduction. The system shall maintain the chiller manufacturer's minimum flow requirements at all times.
- 10.3.5.3.** Variable speed pumping for 7-1/2 horsepower and larger shall be evaluated for energy-saving potential using the LCCA process.
- 10.3.5.4.** When multiple chillers are used, primary and secondary pumping systems with variable speed pumping shall be used.
- 10.3.6.** Each closed-loop system shall be provided with a manual chemical water treatment system to prevent corrosion and scaling in the chilled water system.
- 10.3.7.** If any part of the chilled water system is exposed to freezing conditions, the chilled water shall be protected with an antifreeze solution similar to the one described for the heating system in 10.2.8, above.
- 10.3.8.** Cooling towers shall be either induced draft (cross-flow) units or forced draft (counter-flow) units.
- 10.3.8.1.** Cooling towers shall be located in areas that optimize their operation and are out of sight of building occupants.
- 10.3.8.2.** Condenser water temperatures shall be selected for efficiency.
- 10.3.8.3.** Cooling towers shall be sized to maintain condenser water temperature to the chillers during a design day with ambient wet-bulb temperatures equal to the 2½ percent design wet-bulb temperature.
- 10.3.8.4.** Capacity reduction methods for cooling towers, such as multiple fans, two-speed fans, variable frequency drives, condenser water



mixing valves, or dump valves, shall be used to maintain condenser water temperature during partial load conditions.

- 10.3.8.5.** A single condenser water-circulating pump shall be used for each water-cooled chiller. Pump components shall be suitable for cooling tower systems.
- 10.3.8.6.** In climates with temperatures below 32°F, a remote sump capable of holding the water for the cooling tower system shall be provided below the cooling tower level within a tempered space, where feasible. If a remote sump is not possible, heat tracing must be provided for exposed piping and for cooling tower sumps exposed to freezing weather.
- 10.3.8.7.** The cooling tower system shall include a makeup water connection that operates automatically through a reduced-pressure backflow preventer.
- 10.3.8.8.** The cooling tower water shall be chemically treated by either manual additions or by an automatic injector water treatment system.
- 10.3.9.** Valves for shut off service and throttling shall be ball type for piping diameters 2" and less and butterfly type for 2-1/2" and larger. Use of gate and globe valves shall be prohibited.

#### **10030-11. Water Quality and Treatment**

- 11.1.** A filter/feeder-type manual "shot feeder" water treatment system shall be used for boiler and chiller closed-loop systems. Manual or automatic basin injection water treatment shall be used for cooling towers.
- 11.2.** The contractor shall have the makeup water system tested for the following: pH, hardness, calcium, magnesium, alkalinity, chloride, and other materials.
- 11.3.** Chemical treatment shall bring the makeup water to the boiler/chiller manufacturer's specifications.

#### **10030-12. Mechanical Requirements for Specific Spaces**

- 12.1.** Chambers suites shall be independently controlled and zoned to enable off-hours temperature control.
- 12.2.** For security equipment closet requirements, see Chapter 13 (Courthouse Security). For telecommunication equipment rooms, see Chapter 13 (Telecommunications and Audiovisual Criteria).
- 12.3.** Building entrance vestibules and lobbies shall have sufficient heating and cooling to offset the base load plus the infiltration to the space.
- 12.4.** Systems dedicated to spaces with intermittent occupancy, such as elevator machine rooms, telephone equipment rooms, and similar spaces, shall be exempt from the requirement of an economizer cycle. A waterside economizer

system shall be employed where an airside economizer is not practical or feasible.

- 12.5. The HVAC system serving detention areas shall be designed for continuous operation and shall be independently controlled and zoned. All ductwork and air circulation openings penetrating the secure area envelope, including prisoner circulation areas, shall be designed for maximum security, with security bars and tamper-resistant diffusers with openings no greater than 3/16" in diameter. Holding areas shall be negatively pressurized with regard to adjacent spaces and exhausted directly outdoors.
- 12.6. Mailrooms shall have segregated exhaust under negative pressure and be maintained under a negative pressure condition relative to surrounding spaces if required by the threat assessment.
- 12.7. Water lines shall not be located directly above motor control centers or disconnect switches. The mechanical rooms shall have sloped floors with floor drains in proximity to the equipment served.
- 12.8. Electrical and communication equipment rooms: No water lines are permitted in or overhead in electrical and communication rooms, except for fire sprinkler piping or chilled water and condenser water piping serving the dedicated cooling equipment in the room.
- 12.9. Elevator machine rooms: A cooling or ventilating system must be provided to maintain elevator machine room temperature and humidity as required by geographical location. Only equipment specifically required to provide cooling or heating shall be allowed in the elevator machinery room. Any systems or components which are not required for the cooling or ventilation system shall be located outside of the machinery room. If hoist way venting is required by code and if the building is a high-rise, provide an automatic damper that is controlled by the smoke detector in the hoist way.
- 12.10. Emergency generator rooms: The environmental systems shall meet the requirements of NFPA Standard 110 (Emergency and Standby Power Systems) and meet the combustion air requirements of the equipment. Rooms must be ventilated sufficiently to remove heat gain from equipment operation. The air supply and exhaust shall be located so air does not short circuit. Generator exhaust shall be carried up to roof level. Horizontal exhaust through the building wall shall be avoided.
- 12.11. UPS designated battery rooms: Design space to accommodate battery and exhaust requirements.
- 12.12. Loading docks and sallyports: The entrances and exits at loading docks and service entrances shall be designed to reduce infiltration and collection of outside debris. Loading docks must be maintained at negative pressure relative to the rest of the building. Enclosed vehicle sallyports shall be ventilated to prevent buildup of engine exhaust fumes and transferring of fumes into the building. Sallyports shall be equipped with ventilation fans controlled by

carbon monoxide detection and control system to automatically purge the sallyport when unsafe levels of carbon monoxide are detected. The carbon monoxide sensors shall be uniformly located throughout the enclosed space and near each stairwell or exit.

- 12.13.** Copy areas: All copy areas shall have a localized exhaust adjacent to high-volume reproduction machinery and shall be negative in pressure to the surrounding areas.
- 12.14.** Housing/ Holding Cells: All housing or holding with plumbing fixtures shall be provided with 100% exhaust at a rate of 1.0 cfm/sf. At least 5 cfm/sf of outside air shall be provided as part of the supply air to each cell. Excess return air from other zones within the facility may be utilized as part of the supply air. Unused outside air from other zones may be counted as part of the outside air requirement to each cell. Where feasible economizer return air from other zones may be utilized for part or all of the supply air stream to each cell.
- 12.15.** Isolation/Observation Rooms: Where required tuberculosis (TB) isolation rooms shall be provided with 12 air changes per hour at 100% exhaust. All exhaust from isolation or observation rooms shall be provided from an exhaust fan which is independent of all other systems. Upblast discharge shall be utilized and shall be located no less than 20 feet horizontally and 3 feet above all other building intakes or openings (excluding plumbing vents).

**10030-13. Mechanical Requirements for Areas with Detainees**

- 13.1.** Install mechanical equipment outside secured areas where detainees are potentially located in an unsupervised manner.
- 13.2.** Equipment shall be accessible for maintenance without accessing the secured areas.
- 13.3.** Use security grade fasteners in locations where detainees are potentially located.
- 13.4.** Install security bars in all mechanical openings or penetrations through secure rated wall or barriers that are larger than 8" by 8". This includes all exterior building louvers. The penetrated wall or barrier shall be sleeved with a 3/16" continuously welded steel plate. It shall be poured in place or set with concrete block or welded or bolted to the wall on one side only. End frames shall be 1x1x3/16 inch angles welded to the sleeve. Horizontal and vertical bars shall be 1" dramatic steel, spaced at 6" and welded together and to the sleeve. Provide drawings details for installation requirements in contract documents.
- 13.5.** Diffusers and supply/exhaust grilles installed in wall or ceilings shall conform with the National Institute of Corrections Guidelines (latest version) for Suicide Prevention. In general, the grille or diffuser face plate shall be a perforated 3/16" steel plate with a welded steel flanged border. A steel sleeve similar to that in 13.4 shall be used in all penetrations. The grille shall be tested in accordance with ANSI/ASHRAE 70. Each air device shall be

securely anchored to the surrounding wall or ceiling by an approved method. Provide drawing details for installation requirements in contract documents.

**10030-14. Vibration and Noise Isolation**

- 14.1. All air handling equipment, ductwork, and piping systems shall be properly isolated to prevent vibration transmission to spaces. Vibration of equipment shall be within manufacturer's acceptable limits.

**10030-15. Seismic Design Requirements**

- 15.1. Equipment and distribution systems shall be restrained in accordance with ARCOM MASTERSPEC 23 05 48 Vibration and Seismic Controls for HVAC Piping and Equipment.
- 15.2. Seismic zones shall be determined in accordance with the Chapter 9, "Structural," in this handbook.

**10030-16. Testing, Adjusting, and Balancing**

- 16.1. All hydronic and air systems shall be tested, adjusted, and balanced in accordance with the National Environmental Balancing Bureau's (NEBB's) Procedural Standards for Testing Adjusting Balancing of Environmental Systems. Additional requirements shall be in accordance with ARCOM MASTERSPEC 23 05 93 Testing, Adjusting, and Balancing for HVAC.

**10030-17. System Commissioning**

- 17.1. All mechanical systems, including HVAC, plumbing, controls, energy management, and fuel shall be commissioned in accordance with ARCOM MASTERSPEC 23 08 00 Commissioning of HVAC.
- 17.2. Both fundamental and enhanced commissioning, as identified by LEED, are requirements. Enhanced commissioning requires early project involvement by the Commissioning Agent.
- 17.3. An independent third party will be hired by the BIA for each project. The BIA will be responsible for the contracts and direction for the Commissioning Agent.

**10040-1. General**

- 1.1. All new BIA justice/detention facilities shall have a building management system (BMS) that shall control and monitor space temperatures and lighting, and building energy consumption. These systems shall allow facilities operators to monitor and optimize energy performance, to set space temperatures and lighting levels to help remotely troubleshoot problems, and to gather and store operational data for trending.
- 1.2. The building management system shall be direct digital control (DDC), shall operate over the building fiber optic/cabling IT backbone, and shall report to a remote monitoring station. Switching, connection, programming, coordination, and commissioning of the BMS shall be the responsibility of the DDC contractor. Where applicable, monitoring/control points shall be provided on all major equipment. The system shall have a web server and shall be accessible to a minimum of eight users at the same time using a standard browser for monitoring/logging and remote control of systems.
- 1.3. The BMS Designer of Record shall:
  - 1.3.1. Determine the extent of the BMS required by the local BIA site/buildings.
  - 1.3.2. Set goals for the equipment that the BMS should manage based on needs, LEED requirements, and staff capabilities. The system shall be interoperable with site's scheduled and preventive maintenance system.
  - 1.3.3. Design the BMS to maximize environmental comfort and minimize energy use.
  - 1.3.4. Use land-based Internet communication where available; otherwise, satellite communication shall be used.
  - 1.3.5. Provide DDC points, hardware, software, and interface for all equipment to achieve required control, monitoring, and data logging.
  - 1.3.6. Provide a system that logs all readings for water, gas, and electric usage for the building, including renewable energy systems (if provided).
  - 1.3.7. Provide a system with battery backup power (UPS).
  - 1.3.8. Design a system that allows local manual control if the BMS malfunctions.
  - 1.3.9. Provide generic software, diagnostic tools, wiring diagrams, and manuals that are available on the open market. This includes, but is not limited to, a web browser graphic-based operation, archiving alarms, trends and totals, upload and download programs, diagnostics, change-of-state monitoring, scheduling, reporting, alarming, and backup. All software, diagnostic tools, wiring diagrams, and manuals shall become the property of the BIA.
  - 1.3.10. Design the BMS to include alarms that identify equipment malfunction, security breaches (input from the security system), fire and life safety

conditions (inputs from the fire alarm system), and imminent freeze conditions, e.g., pump failure alarm, duct smoke detector, and freestat alarm.

**10040-2. Design Documents**

- 2.1.** A detailed input/output (I/O) list, flow and control diagrams, and a sequence of operation shall be provided for all major equipment and systems at the Design Development submission. This shall include the items listed below and any additional items requested by the BIA.
- 2.2.** Provide location drawing(s) indicating the location of all control sensors, controlled devices (valves, variable air volume [VAV] boxes, etc.), and control panels.

**10040-3. System Requirements**

- 3.1.** The control system and documents (I/O list, control diagrams, and sequence of operation) shall include all major equipment and system components, including:
  - Heating plant; including pumps, valves, boilers, etc.
  - Cooling plant; including pumps, valves, chillers, etc.
  - Air handling units and air distribution systems; including VAV boxes, dampers, etc.
  - Ventilation and exhaust systems; including fans, dampers, etc.
  - Terminal heating; including unit heaters, convectors, etc.
- 3.2.** Additional monitoring points shall be as follows:
  - Differential pressure across each filter bank
  - Btuh of the solar radiation available
  - Carbon dioxide sensors in the space to control ventilation
  - Main service electric consumption and demand, and electric consumption at lighting panels
  - Metered gas consumption
  - Temperatures of kitchen coolers and freezers
  - LEED-required monitor points
- 3.3.** Lighting: Refer to Chapter 11, “Electrical,” for additional lighting and lighting control requirements.
- 3.4.** Security (define with project team): Refer to Chapter 13, “Information Technology,” for monitoring requirements.
- 3.5.** Fire alarm system: Refer to Chapter 11.

**3.5.1.** Monitor inputs from the fire alarm system. While the BMS is not the primary fire alarm reporting system, it should monitor:

- Smoke/fire detectors
- Fire suppression systems
- Fire pump (if needed)
- Emergency generator
- Gas detection alarms

**3.6.** BMS controls and the equipment within the justice/detention building:

**3.6.1.** Require native standard open protocol communication between controllers and systems, including monitoring. This will be provided over the justice/detention facility network and shall be accessible from any computer via a web browser with access to the network. The system will continue to operate in the event of a network failure.

**3.6.2.** Should include multiple levels of log-on security.

**3.6.3.** Shall be run over building fiber optic, network wiring, and/or applicable industry standard cabling on the building network with connection to the Internet. All software and hardware interfaces and building controllers shall use a common open standard protocol such as LonWorks, BACnet, or over Ethernet TCP/IP.

#### **10040-4. Testing, Training, Operations, Maintenance, and Warranties**

**4.1.** Provide for complete testing of the entire BMS and submission of results to the Designer of Record and the BIA for review and approval.

**4.2.** Provide for on-the-job training, where appropriate, for all personnel and staff who will be operating the systems. Training shall be provided at multiple levels appropriate for the staff that will be supporting the systems. Refer to Section 10060, "Training," for further information.

**4.3.** Operations and maintenance (O&M) for these management systems shall be coordinated with the O&M manuals provided by the equipment manufacturers. The BMS contractor or vendor shall provide the O&M manuals for the specific control systems designed as part of the justice/detention facility project.

**4.4.** Maintenance contracts shall be provided for one, two, or five years for the complete BMS, all software, etc. (Refer to Chapter 13, "Information Technology," for requirements for routers, servers, fiber optics, cabling, and termination devices.) Computers and other peripheral devices are not required.

**4.5.** Extended warranties (one, two, or five years) on all hardware and software related to the control system shall be provided. Telephone help and support shall be provided at no cost to the justice / detention facility for a period of one, two, or five years after formal acceptance of the management system.

**10040-5. System Description**

- 5.1.** The system architecture shall eliminate dependence on any single device for alarm reporting and control execution. Each DDC controller shall operate independently by performing its own specified control, alarm management, operator I/O, and data collection. The failure of any single component or network connection shall not disrupt the execution of control sequences at other operational devices.
- 5.2.** A stand-alone DDC controller shall perform all required local control functions without the need for communication with a remote supervisor or host computer, shall have a battery-backed clock, and shall contain the necessary resident firmware to provide peer-to-peer communications with other DDC panels. Stand-alone DDC controllers shall be fully custom programmable, with all software functions and modules resident within the controller.
- 5.3.** The design shall be stand-alone and modular to ensure future expansion capability, whether it is additional control/monitoring points or supervisory functions. The system shall be expandable to 1,500 I/O points without additional front-end components and/or software.
- 5.4.** The system shall be fully user programmable.
  - 5.4.1.** The system shall incorporate a software editor that allows online viewing of the DDC programs as they are being executed.
  - 5.4.2.** It shall be possible for the user to copy all parameters and custom software from each DDC panel to tape, CD, or flash memory device for backup without the use of special compilers or engineering software.
  - 5.4.3.** It shall be possible for the user to copy all parameters and custom software to each DDC panel from a local port at each panel, and/or from the operator's terminal, without the need for special engineering software and/or erasable programmable read-only memory (EPROM) chip reconfiguration.
  - 5.4.4.** The database parameters and custom software for each primary DDC panel shall be totally resident within the panel in the form of nonvolatile read/write electrically erasable programmable read-only memory (EEPROM), flash memory, or battery-backed random-access memory (RAM). The use of EPROM for storage of database parameters and/or custom software is not acceptable.
- 5.5.** Provide a separate, stand-alone DDC controller for each air handling unit (AHU) or other HVAC system. It is intended that each unique system be provided with its own resident stand-alone DDC controller. A DDC controller may control more than one air handler, provided that all points associated with any one air handler are assigned to the same DDC controller. Application-specific controllers shall not be utilized except for VAV box controllers, unless specifically approved for use on a given system.



**CHAPTER 10: MECHANICAL**

- 5.6. The operator interface system shall be menu driven and shall provide all system, point, and function identifications and status/alarm messages in the English language without the use of cryptic codes.
- 5.6.1. The operator interface system shall be transparent, permitting the user to access any point for status display and/or to change any parameter (set point, etc.) without knowing the physical location of the local panel and/or terminal block connections for the point.
- 5.6.2. All points of the system shall be accessible from the central DDC panel or from the operators' terminals using menus and/or system/point description techniques.
- 5.7. The system shall be tolerant of power failures. Memories shall be nonvolatile, or the unit shall hold a memory up to 48 hours, minimum, on backup batteries. At least one UPS battery-backed (48-hour minimum) real-time clock shall be furnished for each building stand-alone controller. Upon system or power failure, the system shall maintain all DDC control functions in their present position or a fail-safe condition. On power restoration, automatically and without operator intervention, the following restart procedures should be executed:
- Come online
  - Update all monitored functions
  - Resume operation based on current time and status
  - Implement special building start-up strategies as required
- 5.8. The software required to provide the initial operation routines shall not consume more than 70 percent of the programmable capability of the building controllers.
- 5.9. The response time for the controllers to sense an event, make the appropriate calculations, transmit data through the network, and have a remote controller issue the required commands shall be less than the timing requirements to the systems controlled.

**10040-6. Energy Management**

- 6.1. Demand-limiting programs and optimum start/stop programs shall be considered for each project. Refer to Section 10030 for additional energy management opportunities.
- 6.2. The system shall continuously monitor all supplied energy sources which includes water, electrical and gas consumption. Sub-metering shall be required for each controlled lighting zone. The system shall be programmed to capture energy consumption data on an hourly basis and trend it annually.

**10050-1. General****1.1. Water Conservation**

- 1.1.1. Maximize water efficiency within the buildings as outlined in the U.S. Green Building Council's LEED-NC rating system. Employ strategies that in total use less than the baseline calculated for the building after meeting the Energy Policy Act of 1992 fixture performance requirements.
- 1.1.2. Utilize a combination of water-conserving fixtures and equipment, such as low-flow toilets and urinals, low-flow showerheads, and high-efficiency dishwashers and laundry appliances.

**1.2. Solar Energy Domestic Hot Water**

- 1.2.1. Evaluate the use of solar energy to generate domestic hot water (DHW). Provide a life-cycle cost analysis (LCCA) for system evaluation.
- 1.2.2. Solar hot water generation maybe the primary source of hot water or it may be used to preheat water for a fuel-fired system.

**1.3. Potable Water Systems**

- 1.3.1. *Piping System.* Piping materials and sizes shall comply with the recommendations in the Uniform Plumbing Code (used by NFPA 5000). Flow velocities in water pipes shall not exceed 6 feet per second. All piping shall be sloped to permit complete drainage and must be properly supported with allowances for expansion and contraction. Expansion loops or expansion joints and anchor points shall be shown on the plumbing drawings. Piping that is subject to freezing shall be suitably protected.
- 1.3.2. All buildings shall include a potable domestic water system serving all sinks, toilets, showers, food service, custodial needs, hose bibbs, heating and chilled water plant fill systems, and drinking water coolers/fountains. All municipal domestic water entering the building, makeup water for boilers/chilled water systems, and water connections to outside the building shall pass through reduced-pressure backflow preventers to prevent the contamination of indoor potable water.
- 1.3.3. Water distribution throughout the facility shall be through piping systems located above ceilings. Piping shall not be installed under slabs unless accessible for maintenance.
- 1.3.4. Domestic water systems within the building shall be of copper tubing. Use of polyvinyl chloride, chlorinated polyvinyl chloride, or polybutylene material shall not be permitted.
- 1.3.5. Water piping to island sinks shall be in an accessible trench in the floor with a removable cover, or in the ceiling space of the floor below.
- 1.3.6. The required pressure for operation of the furthest fixture from the incoming service will determine if a pressure booster system will be

required. The booster system should be a packaged unit that includes all controls. Provide a constant-speed duplex pump package with bladder-type compression tank to meet the flow requirements.

- 1.3.7. Insulate piping to the minimum requirements of ASHRAE 90.1.
- 1.3.8. Locate the water meter inside the mechanical room unless otherwise directed by the local utility.

#### 1.4. **Determining Plumbing Fixture Count**

- 1.4.1. The Uniform Plumbing Code shall be used to identify the minimum number of fixtures required for water closets, urinals, drinking fountains and lavatories. The number of required fixtures shall be determined by using the occupant load of the building based upon the minimum exiting requirements indicated in NFPA 101, Life Safety Code. The Uniform Plumbing Code is a derivative of the Uniform Building Code.
- 1.4.2. In the Uniform Building Code, ancillary spaces can be deducted when calculating certain requirements. Because one person cannot occupy two spaces simultaneously, the square footage of ancillary spaces shall not be counted when applying the provisions of the Uniform Plumbing Code.
- 1.4.3. Ancillary spaces shall consist of the following, or similar, types of spaces:
  - Support spaces
  - Housing Day rooms

- 1.5. Plumbing shall not pass through or over a telecommunication room or an electrical room.

#### 10050-2. **Domestic Water Heater Systems**

- 2.1. Domestic hot water may be generated from the following systems according to application:
  - A fuel-fired water heater with a separate storage tank
  - A fuel-fired water heater with an integral tank
  - A packaged solar domestic hot water system
  - A packaged domestic hot water preheat system coupled with a fuel-fired water heater
  - An instantaneous point-of-use electric water heater for remote locations in a building only
- 2.2. Fuel-fired, condensing water heaters with separate insulated storage tanks should be used for systems with a large hot water demand kitchens, and gyms. DHW heaters serving kitchens shall have redundant heating units for each storage tank.
- 2.3. Fuel-fired units with an integral tank shall be considered for use in applications that do not have dishwashers or locker rooms.

- 2.4. Domestic hot water temperatures shall be 140°F for water storage tanks, 110°F tempered water for lavatories and showers, and 140°F for kitchen equipment.
- 2.5. Thermostatic mixing valves shall be used to maintain a maximum temperature of 110°F to all lavatories and showers.
- 2.6. A hot water recirculating system shall be required if the length of the hot water piping is greater than 50 feet from the heater to the distribution points. A DHW recirculation system shall operate only during periods of building occupancy. This operation shall be controlled by the direct digital control (DDC) system.

#### **10050-3. Waste, Vent, and Stormwater Piping Systems**

- 3.1. Below-grade piping materials shall include Schedule 40 polyvinyl chloride with solvent joints or cast iron with hub and spigot fittings.
- 3.2. Plenum and above-grade piping shall be either cast iron with no-hub fittings, with approved hanger spacing, or Schedule 40 polyvinyl chloride. Schedule 40 polyvinyl chloride is not approved for use in a plenum space unless it is wrapped with a fire protective material acceptable to code.
- 3.3. Fill material around piping that is below slab shall be compacted granular type to 95 percent modified Proctor. Piping shall not be installed directly under walls. A minimum parallel distance from a wall to the pipe shall be 3 feet. This space is necessary for repair access.
- 3.4. Sewer cleanouts shall be installed at 50 feet on center, and at changes in direction of 90 degrees or more, at the bottom of vertical risers, and as the sewer exits the building.

#### **10050-4. Plumbing Fixtures and Specialties**

- 4.1. Water closets shall be white china, standard flush valve, wall hung, and low-water-consumption type (dual flush or 1.28 gallon per flush, gpf).
- 4.2. Urinals shall be white china, standard flush valve, wall hung, and low-water-consumption type (1/8 gpf). Waterless urinals are not acceptable without prior approval.
- 4.3. Lavatories shall have electronic sensor control for hot and cold water and shall be low-water-consumption type (0.5 gpm or less).
- 4.4. Showers shall be low-water-consumption, pressure-balanced type.
- 4.5. Drinking water coolers/fountains shall be wall hung and handicapped accessible.
- 4.6. Sinks shall be 18-gauge, 302 or 304 stainless steel.
- 4.7. All plumbing fixtures and trim designed or designated for use by the handicapped shall meet Americans with Disabilities Act and Architectural Barriers Act guidelines.

- 4.8. Water supply (hot and/or cold) to the lavatories, sinks, and drinking fountains shall have angle stops with loose key handles.
- 4.9. All wall-hung lavatories, water closets, and urinals shall have chair carriers.
- 4.10. Floor drains shall be installed in each large group restroom, locker room, mechanical room, and kitchen area. Provide a sediment bucket in floor drains where conditions are such that solids may enter the drain.
- 4.11. Showers shall have a hot and cold, single-lever pressure balancing valve with a vandal-resistant head.
- 4.12. Service sinks shall be floor-mounted, molded stone, 10 inches high, with a wall-mounted faucet.
- 4.13. A cold water hose bibb shall be installed in each large group restroom, locker room, and mechanical room. The hose bibb shall be behind a lockable door in restrooms and locker rooms.
- 4.14. If outside potable water pressure exceeds 80 pounds per square inch, a water-pressure-reducing station with two pressure-reducing valves sized for 1/3 and 2/3 flow shall maintain the water pressure in the building to a maximum of 80 pounds per square inch.
- 4.15. Trap primers shall be required on all floor drains. Trap primers shall be accessible for repair.
- 4.16. The use of waterless urinals shall be prohibited unless means for flushing sanitary lines is approved by the BIA.

**10050-5. Plumbing Fixtures and Specialties - Detention and Secure Areas**

- 5.1. Water closets and lavatories shall be detention grade stainless steel combination fixtures.
- 5.2. Security grade fasteners shall be used in all areas subject to access by detainees.
- 5.3. Access for fixtures in detention cells shall be via a mechanical chase located such that maintenance can be performed without accessing the secured area.
- 5.4. The use of pin cleanouts shall be considered and evaluated in the plumbing chases at each cell and holding cell to trap large items that may be thrown into the water closets. This could prevent major facilities plumbing disruptions.
- 5.5. Combination lavatory and toilet fixtures shall be used in individual cells and holding cells. This unit shall be continuously welded, 14 gage stainless steel and arranged to be installed on a finished wall and services from an accessible pipe chase. There shall be no accessible voids or crevices where items can be concealed. The unit shall be ADA compliant when required for handicapped cells. The maximum flush rate shall be 1.6 gpf and the maximum lavatory flow shall be 0.5 gpm.

**10050-6. Plumbing Systems for Food Service Areas**

- 6.1. The ware washing system shall have a booster heater to provide 180°F water.
- 6.2. Provide a three-compartment sink.
- 6.3. An interceptor shall be required (per the Uniform Plumbing Code) to receive the drainage from fixtures and equipment with grease-laden waste located in food preparation areas. Fixtures not requiring an interceptor shall discharge separately and downstream of the interceptor. Where food waste grinders connect to grease traps, a solids interceptor shall separate the discharge before connecting to the grease interceptor. The grease interceptor shall be located on the exterior of the building and will be sized for a 500-gallon minimum capacity, constructed of concrete, with access to grade. The minimum distance from the building to the interceptor shall be 10 feet.
- 6.4. Provide 140°F water to all kitchen equipment and 110°F water for hand-washing lavatories.

**10050-7. Gas Piping Systems**

- 7.1. Low-pressure gas piping (14 inches of water column and less) shall be Schedule 40 carbon steel with screw fittings for piping 1½ inches or less and welded fittings for piping 2 inches or larger.
- 7.2. Gas piping in plenums shall not contain valves or unions and shall have welded joints.
- 7.3. A gas regulator shall be provided to maintain the correct inlet pressure to each gas appliance. The inlet piping at each regulator shall be valved with American Gas Association approved valves.
- 7.4. The maximum gas pressure into the building shall be as established by the local gas company. Provide the gas company with the gas load for each appliance, as well as the minimum and maximum operation pressures for each appliance as early in the design process as possible.
- 7.5. Provide a valve and a dirt leg at each appliance connection.
- 7.6. A solenoid-type automatic shutoff valve with a manual reset shall be provided for all equipment located under kitchen hoods for safety in the event there is a fire under the hood. Such valves are designed to be normally closed unless they are held open by an electric solenoid valve. A mushroom-type wall switch shall be located in the room for solenoid activation as well as interlocked with the hood fire suppression system.
- 7.7. Gas meters shall have pulse output for monitoring energy use via the building energy management system. Meters are required for both natural gas and liquefied propane gas systems.
- 7.8. Anodeless service risers shall be utilized to transition from below grade to service meters.

**10050-8. Valving**

- 8.1.** Valves shall be installed to isolate individual plumbing fixtures and groups of plumbing fixtures to permit shutdown of the fixture or equipment item without affecting the remainder of the building.
- 8.2.** The domestic water system valves shall be bronze construction with ball-type conventional ports up to and including 3-inch piping. Piping 4 inches or larger shall have a butterfly valve.
- 8.3.** Evaluate the need for electrically contracted isolation valves in the cell pipe chases for controlling tempered water flow to cell blocks or to individual cells. Another control approach could be timer activated cell flush valves.

**10050-9. Hangers**

- 9.1.** Provide hangers for all horizontal, suspended, domestic water, gas, sanitary, and storm piping with distances as noted in the state and local codes.

**10050-10. Identification**

- 10.1.** Piping shall be identified for the type of service and direction of flow. Equipment shall be identified with nameplates.

**10060-1. General**

- 1.1. Training requirements for mechanical systems shall be coordinated with the BIA. The extent of training should be based on the needs of the installation personnel. The following shall be used as a guideline for each project. Adjust the quantities to suit the project needs.

**1.1.1. *Training Course Requirements***

- 1.1.1.1. A training course shall be conducted for operating staff members designated by the Contracting Officer in the maintenance and operation of the system, including specified hardware and software.
- 1.1.1.2. The training period, for a total of 40 hours of normal working time, shall be conducted. The first training shall be coincidental with the commissioning period followed by an initial period starting 30 days after successful completion of the commissioning. Additional training shall commence at the 6 month and 1 year periods.
- 1.1.1.3. The training course shall be conducted at the project site.
- 1.1.1.4. Audiovisual equipment and 10 sets of all other training materials and supplies shall be provided.
- 1.1.1.5. A training day is defined as 8 hours of classroom instruction, during the work week.

**1.1.2. *Training Course Content***

- 1.1.2.1. For guidance in planning the required instruction, the contractor shall assume that attendees will have a high school education or equivalent, and are familiar with HVAC systems.
- 1.1.2.2. The training course shall cover all the material contained in the operations and maintenance instructions, the layout and location of each HVAC control panel, the layout of one of each type of unitary equipment and the locations of each, the location of each control device external to the panels, preventive maintenance, troubleshooting, diagnostics, calibration, adjustment, commissioning, tuning, and repair procedures. Typical systems and similar systems may be treated as a group, with instruction on the commissioning report to be presented as benchmarks of HVAC control system performance by which to measure operation and maintenance effectiveness.



**11000-1. Introduction**

- 1.1. This chapter shall be used as a guideline in the development of power, lighting, grounding, fire alarm, lightning protection, and other electrical systems for all new BIA justice/detention facility projects. The design shall be in conformance with these guidelines unless exceptions to them are granted by the BIA.
- 1.2. Refer to Chapter 1, “General Information,” and Chapter 2, “Presentation of Data,” for required documents, drawing and specifications formats, and other design and submittal requirements not discussed in this chapter.
- 1.3. Additional design and submittal requirements may apply for projects with unusual or highly technical criteria.
- 1.4. As applicable, the Designer of Record shall incorporate the sustainability strategies identified in Chapter 3, “LEED Goals and Guidelines.”
- 1.5. The guidelines in this chapter should be used in conjunction with those in the other chapters in this handbook, and the Designer of Record should coordinate with the other project consultants to be sure all aspects of the justice/detention facility are effective and compatible.
- 1.6. All design features must be weighed carefully for their initial cost, long-term maintenance cost and needs, durability, and their impact on the environment.

**11000-2. Documents****2.1. Specifications**

- 2.1.1. Performance specifications shall be provided for fire alarm, photovoltaics, lightning protection, and cathodic protection systems only.
- 2.1.2. Avoid specifying a system or type of equipment manufactured by a single manufacturer.
- 2.1.3. If a particular product is required due to design constraints, notify the BIA and provide recommendations for how to accommodate the situation.
- 2.1.4. Do not specify foreign products or components manufactured to foreign standards.

**2.2. Design Calculations****2.2.1. Required calculations include:**

- Illumination levels as noted in the lighting sections. (The text height on submitted lighting level plans shall be 8 point or 1/16 inch, minimum.)
- Voltage drop.
- Demand loads on panelboards, main service, etc. Include diversification per the National Electrical Code (NEC).
- Phase balancing on panelboards.

- Available short-circuit currents.
- Arc flash study.
- Coordination study.

### 2.3. Submittals

- 2.3.1. Submit the calculations noted above with the construction documents for review at each of the various stages of project submittal and review.
- 2.3.2. Provide catalog data sheets for equipment specified in the construction documents along with the construction documents for review at each of the various stages of project submittal and review.

### 11000-3. Quality Control

- 3.1. Quality control review shall include, but not be limited to, the following:
  - 3.1.1. Verify that the design meets the scope of work.
  - 3.1.2. Verify that the design complies with the design guideline requirements.
  - 3.1.3. Perform a complete, independent review for errors, omissions, or conflicts within and between disciplines.
  - 3.1.4. Verify that equipment locations are accurately indicated.
  - 3.1.5. Verify that all equipment indicated on schedules, one-line diagrams, etc., is indicated on the plans.
  - 3.1.6. Verify that callouts are provided for each piece of equipment.
  - 3.1.7. Verify that equipment clearances and headroom meet NEC and NFPA 5000 requirements.
  - 3.1.8. Verify that no ducts or piping are routed over electrical equipment.
  - 3.1.9. Coordinate ceiling-mounted lights, grilles, fire alarm equipment, etc., so that they are not in conflicting locations.
  - 3.1.10. Motor requirements:
    - Match the callouts and requirements indicated in other disciplines.
    - Verify that all motors are shown on the plans and schedules.
    - Verify that phase and voltage requirements are correct.
    - Verify that starters are appropriate for the motors and motor circuit parameters.
    - Verify that variable frequency drive (VFD) feeders are sized per the NEC and manufacturer's recommendations.
    - Verify that a local disconnect is provided for all motors.
    - Verify that power has been provided to all control panels.

- Verify that power has been provided to all motorized dampers requiring line voltage.
  - Verify that a ground-fault interrupter type receptacle has been provided within 25 feet of roof- and exterior-mounted mechanical equipment.
- 3.1.11.** Verify that the National Electrical Manufacturers Association (NEMA) enclosures called out match the environment they are to be installed in.
- 3.1.12.** Verify that motorized doors and their associated controls are indicated on the plans and match the architectural requirements.
- 3.1.13.** Verify that the legend matches the symbols used on the plans.
- 3.1.14.** Light fixture requirements:
- Verify that fixture symbols indicated on the plans match the schedule callout.
  - Verify that all fixture types indicated on the plans are called out on the schedule.
  - Verify that lighting controls are provided for all areas and rooms.
  - Verify that egress lighting meets code requirements.
  - Verify that exit signs are provided per code for all paths of egress.
- 3.1.15.** Verify that special systems power requirements are indicated and coordinated.
- 3.1.16.** Verify that power has been provided to fuel storage leak detection equipment.
- 3.1.17.** Verify that no sole-source equipment has been specified without BIA authorization.

#### **11000-4. Building Types**

- 4.1.** Designs shall be modified as appropriate for code compliance and best practices for the building type. Possible building types include:
- Justice Center
  - Detention Facility
  - 911 Call Center
  - Maintenance building
  - Kitchens

#### **11000-5. Local Availability**

- 5.1.** Verify local availability of spare parts, replacement parts, and service technicians for the equipment specified.

- 5.2. If equipment is not locally available, determine the response time for obtaining it and verify with the BIA that the amount of time is acceptable.

**11000-6. Warranty**

- 6.1. A minimum of a 1-year warranty from successful start-up shall be provided for all systems.
- 6.2. Additional or extended warranties are noted in other sections of this chapter.
- 6.3. Labor warranty work shall be performed by factory-trained service technicians located within 250 miles of the project site or a distance as appropriate to the site.

**11010-1. Systems Evaluation**

- 1.1. Electrical systems for BIA justice/detention facilities shall be evaluated based on the following criteria. The list is in order of priority, and each criterion is followed by additional information applicable to it.

**1.1.1. *Essential Building Systems***

- Where building systems are essential to the function of the building or facility, the system design shall be more durable than standard design practice.
- If a system is determined to be essential to the operation of the building, consideration shall be given to providing redundancy to the system.

**1.1.2. *Standardization***

- The design shall follow BIA standards.

**1.1.3. *Training Standardization***

- Systems requiring less training are preferred.

**1.1.4. *Operations and Maintenance Concerns***

- Systems requiring less maintenance are preferred.

**1.1.5. *Limitation of Flexibility/Creativity***

- System designs shall be well established within the industry and commonly used for the application.
- The systems designed shall be similar to systems in comparable buildings at other BIA facilities that were also designed according to the guidelines in this handbook.

**1.1.6. *Available Infrastructure***

- The available utilities shall be coordinated with the specific project site at the beginning of the project to ensure that the systems specified can be supported by the local utilities.

- 1.1.7. *Cost.* The life cycle cost analysis of the systems shall include the following:

- Construction costs
- Operating costs
- Maintenance costs

**1.1.8. *Constructability***

- Ease of construction of the proposed system shall be considered.

- The availability of workers skilled in the installation of a proposed system shall be considered.

**1.1.9. LEED**

- Where system selection affects compliance with a LEED credit point, the system shall be designed to meet the LEED requirements.

**1.1.10. Commissioning**

- Systems requiring less commissioning are preferred.

**1.1.11. Site Constraints and Criteria**

- The system proposed shall be compatible with site constraints and requirements, including remote locations, exposure to hazards such as lightning, earthquakes, and flooding, as well as geography, elevation, and other local conditions.

**1.1.12. Climate Influences**

- The system proposed shall be compatible with the climate of the project site.

**1.1.13. Infrastructure Flexibility/Expandability**

- The system design shall be able to accommodate future expansion as required by the BIA.

- 1.2.** Where a clear system selection is *not* readily determined by examining the above criteria, present the information available, relative to those criteria, to the BIA for review and selection.

**11020-1. General**

- 1.1. The electrical design for BIA justice/detention facilities shall comply with all applicable current codes, standards, and laws. For a more general list of codes and standards that apply to BIA justice/detention facilities, refer to Chapter 1, "General Information." During design, report any required deviations from codes and standards to the Contracting Officer.
- 1.2. Where two codes, standards, or laws are applicable to the topic under review, use the more conservative or more stringent. Consult with the BIA Office of Facilities Management and Construction (OFMC) to resolve any questions or conflicts regarding application of codes and standards.
- 1.3. The National Fire Code (NFPA 5000) is the primary code to be followed.
- 1.4. Per Chapter 48 of NFPA 5000, the National Electrical Code (NEC) shall be followed for the design and installation of all electrical equipment unless the requirements of the codes noted below are more stringent.
  - 1.4.1. All requirements noted in the NEC shall be followed, including mandatory, recommended, and advisory rules.

**11020-2. Applicable Codes and Standards**

- 2.1. The design criteria shall comply with the latest edition of the guidelines published by or contained in the following:
  - American National Standards Institute (ANSI)
  - American Society of Heating, Refrigerating and Air-Conditioning Engineers (ASHRAE) 90.1 Energy Standard for Buildings Except Low-Rise Residential Buildings
  - American Society for Testing and Materials (ASTM)
  - Americans with Disabilities Act (ADA) Accessibility Guidelines for Buildings and Facilities (ADAAG)
  - ANSI/American Society of Mechanical Engineers (ASME) A17.1 Safety Code for Elevators and Escalators
  - Architectural Barriers Act (ABA)
  - Illuminating Engineering Society of North America (IESNA)
  - Institute of Electrical and Electronics Engineers (IEEE)
  - Insulated Cable Engineers Association (ICEA)
  - Leadership in Energy and Environmental Design (LEED)
  - Lightning Protection Institute (LPI)
  - NACE International
  - National Electrical Manufacturers Association (NEMA)

- National Fire Protection Association (NFPA), in general and specifically:
  - NFPA 70 National Electrical Code
  - NFPA 70E Standard for Electrical Safety Requirements for Employee Workplaces
  - NFPA 72 National Fire Alarm Code
  - NFPA 75 Standard for the Protection of Information Technology Equipment
  - NFPA 101 Life Safety Code
  - NFPA 110 Standard for Emergency and Standby Power Systems
  - NFPA 111 Standard on Stored Electrical Energy Emergency and Standby Power Systems
  - NFPA 170 Standard for Fire Safety and Emergency Symbols
  - NFPA 780 Standard for the Installation of Lightning Protection Systems
  - NFPA 5000 Building Construction and Safety Code

- Occupational Safety & Health Administration (OSHA)
- Rehabilitation Act of 1973 as amended in 1978, Section 504

**2.2.** Design of the electrical system shall be such that ADA and ABA accessibility requirements are met for device mounting heights, protrusions, lighting, audibility, etc.

**2.3.** Seismic restraint requirements shall be coordinated with the individual site. Local seismic codes shall be considered the minimum requirements.

**2.3.1.** When required for site conditions, fabrication details including anchorages and attachments to structure for large electrical equipment and supported cable trays shall be signed and sealed by a qualified, licensed professional engineer.

### **11020-3. Equipment Requirements**

- 3.1.** All electrical components, devices, and accessories shall be Underwriters Laboratories (UL) listed and labeled as defined in NFPA 70, Article 100, and marked for the intended use.
- 3.2.** All equipment and materials shall be new and unused and shall be in conformance with the current applicable industry standards unless reuse of the equipment is permitted by the BIA.



**11030-1. Utility Coordination**

- 1.1. Verify that there is sufficient load capacity on the utility distribution line to the project site to accommodate the full design demand load and future projected loads. If sufficient capacity is not available:
  - Notify the BIA immediately.
  - Determine potential options for obtaining the required power from the utility company for review by the BIA.
  - Provide to the BIA cost estimates for potential options.
- 1.2. Coordinate the routing of the utility feed to the site and on the site.
  - 1.2.1. Route feeders underground wherever permitted by the utility.
  - 1.2.2. Coordinate with the local utility company for overhead or underground feeder routing.
  - 1.2.3. Do not route feeders under streets or sidewalks except where required to cross the streets or sidewalks.
- 1.3. Coordinate the exact location of the utility transformer on the site. Verify with the utility company the required separation distances and other requirements for transition boxes, exterior current transformer (CT) cabinets, manholes, duct sizes, conductors, etc.
- 1.4. All medium-voltage service equipment and feeders shall be provided and maintained by the utility company wherever possible.
- 1.5. The one-line diagram shall clearly indicate what equipment is to be provided by the utility company and what equipment shall be provided by the contractor.
- 1.6. Obtain an estimate from the utility company for the utility connection, including the transformer and pad, utility poles, service drop, CTs, meter, etc., for inclusion in the construction cost estimate.
- 1.7. Include the following in the project specifications *and* on the drawings:
  - 1.7.1. The contractor shall coordinate with the utility company for exact installation requirements.
  - 1.7.2. The contractor shall be responsible for submitting drawings to the utility company for approval and coordination.
  - 1.7.3. The contractor shall pay all material and labor costs required for the installation of the utility connection. This shall include all costs incurred by the contractor *and* by the utility company. The BIA shall *not* be separately billed for utility connection costs.

**11030-2. Reliability**

- 2.1. Investigate with the utility company the history, reliability, voltage regulation, and quality of power at the proposed site.

- 2.1.1. Obtain the five-year history of outages at the site. Include the number, duration, time, date, and cause of each for review by the BIA.
  - 2.1.2. Develop a probability analysis for the likelihood of future outages of 1, 5, 10, 30, and 60 minutes or longer.
  - 2.1.3. Establish the nominal voltages anticipated at the site.
  - 2.1.4. Determine if there are any impacts on the reliability of the system based on weather conditions.
  - 2.1.5. If the required information is not available from the utility company, coordinate with the BIA to obtain power outage information from other BIA facilities located near the new building site.
- 2.2. Based on the reliability information and remoteness of the new building site, make a recommendation to the BIA about the requirements for emergency and standby power. Refer to Section 11110, "Emergency and Standby Power Systems," for additional information.

### 11030-3. Renewable Energy

- 3.1. Per the U.S. Department of Energy (DOE) EPACT 2005 Federal Renewable Energy Requirement Guidance, a minimum of 5 percent of the building power consumption shall be provided by renewable energy through 2012, and 7.5 percent in 2013 and each year thereafter.
  - 3.1.1. Refer to the DOE state energy alternative website for site-specific information regarding wind and solar resources.
  - 3.1.2. Refer to other web-based design tools for assistance in estimating potential renewable power at specific locations.
  - 3.1.3. Green (wind or other renewable energy source) power may be purchased from the utility company, or a third party, to meet the renewable energy requirement.
- 3.2. The amount of renewable power provided shall be metered and monitored via the direct digital control (DDC) system for Internet monitoring.
- 3.3. Coordinate with the local utility company for available incentives for renewable power installations or energy-saving designs.
- 3.4. Coordinate with the local utility company for required disconnecting means and/or protective relaying requirements to prevent backfeeding the utility lines when maintenance is required.
- 3.5. Integration of renewable energy systems shall be included early in the design process to facilitate the integration of the system into the building design.
- 3.6. Battery backup of renewable energy systems is not recommended due to cost and maintenance, unless the system is required in a remote location or no other power source is provided to the building or device.

**3.7.** Obtain a copy of the utility interconnection agreement for review by the BIA legal department prior to proceeding with including renewable energy on the project.

**3.8. Photovoltaics**

**3.8.1.** Photovoltaics are particularly recommended for cool, dry climates and areas of high solar gain. Each site shall be evaluated for the appropriateness of photovoltaics, and a recommendation shall be provided to the BIA on whether or not to include them in the design.

**3.8.2.** Provide anti-theft provisions for photovoltaic systems.

**3.8.3.** Building-integrated solar modules shall be provided to conserve land whenever possible. Some options for incorporating photovoltaics into the building include:

- An array used as a covered walkway or shading device.
- A solar carport where photovoltaic cells are used as shading for parking areas.

**3.8.4.** Photovoltaic systems shall be located and oriented to maximize the average amount of insolation on the system.

**3.8.4.1.** The location for the photovoltaic system shall be selected so as to maximize the southern exposure of the system and guard against shading the solar panels.

**3.8.4.2.** Verify that no obstructions interfere with the summer and winter sun paths to the photovoltaic system. Relocate panels if required to avoid obstructions.

**3.8.4.3.** Coordinate with the landscape architect to ensure that tall trees are not located where they will throw shade on the system in the future after the trees reach their anticipated height.

**3.8.4.4.** Coordinate the location of the system with the site master plan to prevent shading from future building installations.

**3.8.5.** Consideration shall be given to stand-alone photovoltaic systems for small, remote loads where a stand-alone system may be more cost effective than wiring back to the distribution system.

**3.8.5.1.** Parking, walkway lighting, caution lights at street crossings, security lights, emergency (EM) telephone call boxes, remote signage, etc., are examples of potential stand-alone systems.

**3.8.5.2.** Battery storage is required for stand-alone systems where permitted in paragraph 3.6, above.

**3.8.6.** Additional maintenance is required for photovoltaic systems. This should be discussed with the BIA prior to including photovoltaics in the design.



- 3.12. Where on-site power generation is provided, an educational display shall be provided in a public area to describe the system.

**11030-4. Daylighting**

- 4.1. Daylighting shall be incorporated into each building design, wherever possible without infringing upon security issues, due to the quick payback period and energy efficiency of the systems. Note that daylight is not considered as a renewable energy source.
- 4.2. Refer to Section 11060, “Interior Lighting Systems,” for additional information and requirements.

**11030-5. Cable Television, Telephone, Data**

- 5.1. Refer to Chapter 13, “Information Technology,” for additional information and infrastructure requirements.

**11040-1. Service Entrance**

- 1.1. Locate the service entrance to the building close to the utility service approach for easy connection and coordination.
  - 1.1.1. Coordinate with the local utility company for exact requirements.
  - 1.1.2. Coordinate the location of the utility service, transformer, current transformer (CT) cabinet, and meter with the utility company.
  - 1.1.3. Minimize the aesthetic impact of the utility equipment on the building.
- 1.2. Determine if trenching and backfilling, additional transition boxes or other equipment are required by the utility company.
- 1.3. Provide conduit in a trench from the utility transformer to the building service unless noted otherwise.
  - 1.3.1. Provide non-reinforced concrete encased duct bank with minimum 4-inch, Schedule 80 PVC conduits for underground primary and secondary feeders located under roadbeds or where subject to damage or mechanical injury.
  - 1.3.2. Provide a minimum of one spare 4-inch conduit in the duct bank and one additional spare conduit for every four conduits required.
  - 1.3.3. All elbows and risers shall be PVC-coated rigid galvanized steel conduit.
  - 1.3.4. Underground splices are not permitted except in manholes, vaults, etc.
- 1.4. Provide a 480-volt, 3-phase, 4-wire distribution system, unless 3-phase power is not available at the site or the service size is small.
  - 1.4.1. All buildings with service of greater than 200 amps, including outbuildings, shall be 3-phase where available.
  - 1.4.2. A minimum of a 3-wire, 120/208-volt panelboard shall be provided for any building with more than one circuit required.
  - 1.4.3. Provide a single-point disconnecting means for an *entire* campus when required by the BIA.
- 1.5. The electrical service shall be sized to accommodate future expansion and phasing in addition to spare capacity as prescribed in this and other sections of this handbook.
  - 1.5.1. If the project includes future growth or phasing that will require additional utility and service equipment, the construction documents shall address only the current construction with minimal expense for future or phased work.
    - 1.5.1.1. Exception: If the future construction will follow very closely the end of the current construction or if expressly authorized by the BIA.

**11040-2. Space Coordination**

- 2.1. Coordinate with the design architect to ensure adequate space is provided for all electrical equipment, including switchboards, panelboards, transformers, lighting contactors, transient voltage surge suppressor (TVSS) equipment, disconnects, etc.
- 2.2. Coordinate with the design architect for any chase or riser requirements for all conduit systems, including power, telecom, fire alarm, security, etc.
- 2.3. Obtain a plan from the architect differentiating the areas for inmates, the public, and staff to establish design criteria for the different areas of the building.

**11040-3. Metering**

- 3.1. Provide metering to meet LEED requirements.
- 3.2. Coordinate with local utilities for utility metering requirements.
  - 3.2.1. It is recommended that the utility company meter be located outside the building for access by the utility company.
  - 3.2.2. Determine whether CT cabinets are to be located inside or outside the building.
- 3.3. The main distribution panel (MDP) for each building shall be provided with owner-provided digital metering for amperage, watts, voltage, power factor, peak demand, kilowatts, volt-amperes, total harmonic distortion, and shall be tied to the direct digital control (DDC) system for monitoring.
- 3.4. Provide metering for motor control centers (MCCs) for potential load shedding via DDC controls.
- 3.5. Provide 3/4-inch conduit from the gas meter(s) to the main telecom room.
- 3.6. Provide 3/4-inch conduit from the water meter(s) to the main telecom room.
- 3.7. Provide 3/4-inch conduit from the electric meter(s) to the main telecom room.

**11040-4. Service Distribution**

- 4.1. Distribution shall be via switchboards.
- 4.2. Bus bars shall be copper.
- 4.3. Provide a lightning arrester at the MDP.
- 4.4. Provide a surge protection device (SPD) at the MDP.
- 4.5. Provide a surge protection device (SPD) at all distribution boards.
- 4.6. Provide 30 percent spare capacity and 30 percent spare space for the MDP. Ask the BIA about anticipated future expansion that could be accommodated in the original design.
- 4.7. Provide 30 percent spare capacity and 30 percent spare space for distribution panels.

- 4.8. Provide ground fault circuit interrupting (GFCI) protection for equipment rated 1,000 amps or larger.
  - 4.8.1. Where ground fault protection is provided, provide ground fault protection on the next level of distribution equipment to provide better coordination.
- 4.9. Specify an MCC where six or more 3-horsepower or larger motors are grouped. Provide 20 percent space capacity of size one spaces.
- 4.10. Verify that sufficient space is available for equipment supplied by any of three separate manufacturers. The design shall be based upon the footprint, height, depth, etc., of the largest representation of the equipment type.
- 4.11. Feeders to panelboards shall be sized to match the panelboard bus rating and shall have 200 percent neutrals where feeding nonlinear loads.
- 4.12. Verify the future connection requirements to portable buildings, if required.
- 4.13. Elevator(s) shall be fed from the MDP.
- 4.14. Do not locate the MDP in a mechanical heating or cooling room or generator room. Provide a dedicated electrical room for distribution electrical equipment.
- 4.15. Provide equipment fully rated for the available fault current.
- 4.16. Increase conductor sizes to limit voltage drop to 2 percent or less for feeders.
- 4.17. All exterior equipment shall be NEMA 3R or 4X rated.

#### **11040-5. Grounding**

- 5.1. Refer to Section 11050, "Grounding System," for additional information.
- 5.2. Refer to Section 11120, "Lightning Protection," for additional information.

#### **11040-6. Panelboards**

- 6.1. Provide a minimum of 25 percent spare space and load capacity for future growth.
- 6.2. The loading of each phase of the panelboards shall be balanced to within 10 percent.
- 6.3. Provide bolt-on molded-case circuit breakers of minimum 20-amp size, unless 15-amp size is required for feeding a motor.
- 6.4. Provide a maximum of 42 breakers per panel. Discuss any unusual circumstances requiring more breakers with the BIA for approval.
- 6.5. Provide door-in hinged-front cover construction.
- 6.6. Provide an insulated neutral and ground bus bar in each panelboard.
- 6.7. The minimum amps interrupting capacity (AIC) rating shall be 10,000 for 208-volt panelboards and 14,000 for 480-volt panelboards.
- 6.8. Panels shall be lockable. All panels shall be keyed alike. Furnish a minimum of two keys per each lock installed.



- 6.9. Recess-mount panelboards except in an electrical or utility space and unless prohibited by special circumstances (e.g., a fire-rated wall). Discuss unusual circumstances with the BIA for approval.
- 6.10. Provide sufficient access and working space per the NEC and to maintain safe working conditions.
- 6.11. Provide a separate panelboard for communication closets.
- 6.12. Providing a separate panelboard for computer rooms and labs with 12 or more computers.
- 6.13. Provide a separate panelboard for each courtroom and associated jury suite, circulation spaces, and miscellaneous spaces.
- 6.14. Provide NEC-required load calculations on panel schedules for all panelboards.
  - 6.14.1. Indicate the panel name, voltage, phase, amperage, AIC, and from where the panel is fed.
  - 6.14.2. Indicate all branch loads on each circuit. Note the type of load served and the associated room numbers.
  - 6.14.3. Note spare circuits.
  - 6.14.4. Note available breaker space.
  - 6.14.5. Indicate as “Non-usable” any spaces that are not usable due to obstructions, bus configuration, panel capacity, etc.
- 6.15. Provide surge suppression device for panels feeding communication rooms, computer rooms, a fire alarm control panel (FACP), sensitive electronic equipment, or computers.
- 6.16. Provide equipment fully rated for available fault current.

#### 11040-7. Transformers

- 7.1. Insulation class shall be 220°C with all insulation materials flame-retardant and unable to support combustion as defined in ASTM Standard Test Method D635. The maximum rated temperature rise shall be 115°C above 40°C.
- 7.2. Provide high-efficiency, Energy Star-rated transformers. Transformers shall be K-rated or harmonic cancelling where serving nonlinear loads in excess of 30% of their capacity.
- 7.3. Provide six 2.5 percent taps, two above and four below normal full capacity.
- 7.4. The sound level rating shall not exceed those listed in NEMA TR 1 Transformers, Regulators, and Reactors.
- 7.5. Provide vibration isolations pads for all transformers, along with rubber washers for all mounting bolts.
- 7.6. Avoid locating transformers where the magnetic fields generated could interfere with TVs, monitors, radios, voice, data, or other equipment.

- 7.7. Where transformers are wall-mounted, provide factory mounting brackets.
- 7.8. Do not locate transformers of more than 5kVA above ceilings.

**11040-8. Raceway Systems**

- 8.1. Provide separate, complete raceway systems for 120-volt, 277-volt, lighting, power, emergency power, standby power, fire alarm, communications, security, audio/visual, public address, and mechanical control cabling. Mingling of conductors shall not be permitted unless noted otherwise.
- 8.2. All wiring shall be installed in metallic raceways unless noted otherwise.
- 8.3. Minimum conduit size shall be 3/4-inch.
- 8.4. Metallic rigid conduit options include:
  - Intermediate
  - Rigid metal
  - Rigid galvanized metal
  - Electrical metallic conduit
- 8.5. Flexible conduit must be:
  - Liquid-tight
  - Steel
  - No more than 6 feet long
  - Provided to all vibrating equipment, motors, and transformers
- 8.6. Surface raceway shall be metallic Wiremold or equal. The conduit feed to the Wiremold shall be recessed, but the Wiremold shall be surface mounted.
- 8.7. Conceal conduit except in unfinished spaces, warehouses, machine shops, and service areas unless noted otherwise. Surface mounted raceway or exposed conduit is not permitted in the holding areas or detention areas under any circumstances.
- 8.8. Conduits for power and special systems shall be kept separated.
  - 8.8.1. For 480/277 volt systems, provide the following separation:
    - 8.8.1.1. Provide 24 inches of separation where power and special system conduits run parallel.
    - 8.8.1.2. Provide 12 inches of separation where power and special system conduits cross.
  - 8.8.2. For 208/120 volt systems, provide the following separation:
    - 8.8.2.1. Provide 12 inches of separation where power and special system conduits run parallel.

- 8.8.2.2.** Provide 6 inches of separation where power and special system conduits cross.
- 8.9.** Buried conduit, other than service entrance feeder conduits, shall be a minimum of Schedule 40 PVC conduits with PVC-coated rigid galvanized steel elbows and risers.
- 8.10.** Buried conduit shall be a minimum of 36 inches below grade and shall be provided with metallic warning tape 6 to 12 inches below grade routed above the conduit.
- 8.11.** Provide junction boxes for all pull box locations, splices, and taps.
- 8.12.** All conduit penetrations through fire-rated walls shall be sealed to maintain the fire rating.
- 8.13.** Mount conduit above accessible ceilings a minimum of 2 feet above the ceiling grid or tight to the structure, whichever is lower.
- 8.14.** Electrical nonmetallic tubing, armored cable, and metal-clad cable are not acceptable without written permission from the BIA.
- 8.15.** Power poles may be used on a case by case basis if approved by the BIA.

**11040-9. Conductors**

- 9.1.** Conductors shall be copper.
- 9.2.** Conductors shall have a 75°C rating, minimum.
- 9.3.** Conductors shall be #12 minimum size for power, #14 for control.
  - 9.3.1.** Control wiring within detention areas shall be installed in conduit.
- 9.4.** Conductors shall have a maximum cable size of 500 MCM.
  - 9.4.1.** Provide parallel runs where increased amperage is required.
- 9.5.** Wires: #10 and #12 wires may be stranded or solid wires. All other sizes shall be stranded wires.
- 9.6.** Circuits 75 feet long or longer shall be provided with #10 or larger wiring for 120-volt circuits for voltage drop. Increase conductor size for longer runs to limit the voltage drop to 3 percent or less.
- 9.7.** Circuits 150 feet long or longer shall be provided with #10 or larger wiring for 277-volt circuits for voltage drop. Increase conductor size for longer runs to limit the voltage drop to 3 percent or less.
- 9.8.** Wire insulation shall be THWN or THHN unless otherwise required by code.
- 9.9.** Provide a dedicated neutral conductor for each circuit. Providing a common neutral for multiple branch circuits is *not* permitted.

**11040-10. Branch Circuits**

- 10.1.** Lighting circuits shall be loaded to only 75 percent for future addition.

**10.2.** Do not combine lighting and receptacle power on the same circuit, except in elevator pits.

**10.3.** Do not combine computer and general purpose power on the same circuit.

**10.4. Motors**

**10.4.1.** Motors of 1/2 horsepower or less shall be 120-volt.

**10.4.2.** Motors of 3/4 horsepower or larger shall be 3-phase, 480-volt or 208-volt.

**10.4.2.1.** Provide phase loss protection for motors of 5 horsepower and larger.

**10.4.3.** The minimum breaker trip setting for motors shall be 15 amps.

**10.4.4.** Provide solid state overload protection for all motors.

**10.4.5.** Match the electrical callouts to the mechanical plan designations.

**10.4.6.** Where delayed start of motors is required to reduce generator peak loading, the start delay shall be provided via DDC controls sequencing the restarting of large motors.

**10.4.7.** Use NEC tables for minimum conductor current ratings, overcurrent protection sizing, etc.

**10.4.7.1.** Larger equipment sizes shall be permitted, but shall not exceed NEC limitations.

**10.4.7.2.** Manufacturer's recommendations shall govern if equipment requirements are more stringent than the NEC requirements.

**10.4.7.3.** For packaged mechanical equipment, the manufacturer's recommendations for connection requirements shall govern.

**10.4.8.** Air-cooled chillers shall be provided with a fused disconnect unless otherwise required by the manufacturer.

**10.4.9. *Variable Frequency Drives (VFDs)***

**10.4.9.1.** Locate VFDs within 50 feet of the motor to be served.

**10.4.9.2.** VFDs shall not be located within an MCC due to potential heat damage.

**10.4.9.3.** Follow NEC requirements for minimum conductor current ratings, overcurrent protection sizing, etc.

**10.4.9.4.** Where VFDs are installed in a location remote from the local disconnecting means, an interlock shall be provided between the disconnect and the VFD so that the VFD will not attempt to power the equipment if the disconnect is in the off position.

**10.4.9.5.** VFDs shall be provided with bypass to maintain equipment function in the event of the VFD failure.

- 10.5. Show all equipment locations (transformers, panels, motors, etc.) on the drawings including required access and working clearances.
- 10.6. Provide power to all equipment requiring power to provide a complete, fully operational system.
- 10.7. Provide power to all mechanical control panels.
- 10.8. Verify the division of work between the mechanical and electrical contractor is clearly defined, with particular attention paid to definitively indicating who provides the disconnect switches, starters, VFDs, and control wiring.

#### 11040-11. Receptacles

##### 11.1. Location

- 11.1.1. Locate receptacles where required by code.
- 11.1.2. Locate receptacles where required for specific equipment.
- 11.1.3. Locate receptacles where required by facility operating requirements.
- 11.1.4. Receptacles on opposite sides of the same wall shall be horizontally offset a minimum of 6 inches. Maintain the fire rating of the wall.
- 11.1.5. Maximum spacing for interior locations shall be 25 feet on center, except in detention areas.
- 11.1.6. Maximum spacing in detention areas shall be 50 feet.
  - 11.1.6.1. Where possible, avoid locating receptacles so that cords pass in front of doors to cells.
- 11.1.7. Locate one exterior receptacle at each exit and at 100 feet on center around the exterior of the building, except in inmate accessible areas.
- 11.1.8. Locate one exterior receptacle at each standby/emergency generator.
- 11.1.9. Locate a receptacle within 25 feet of all exterior and roof mounted mechanical equipment, including air handling units (AHUs), chillers, condensing units, etc.
- 11.1.10. Each public restroom shall be provided with one GFCI receptacle per each two sinks.
- 11.1.11. Provide separate receptacles for a microwave and refrigerator for feeding inmates returning late from court. Coordinate location with the architect.
- 11.1.12. Provide dedicated receptacles for the break room coffee machine, microwave, refrigerator, vending machines, etc.
- 11.1.13. Recessed, floor-mounted receptacles are not permitted unless noted otherwise or deemed necessary and appropriate for the application and approved by the BIA.

- 11.1.14. In kitchen areas, pedestal-type floor-mounted receptacles are required for free-standing equipment.
- 11.1.15. Receptacles in electrical rooms, mechanical rooms, maintenance areas, or workshops shall be mounted at +48 inches, minimum, and shall be GFCI protected.
- 11.1.16. Telecom closet receptacles shall be per Chapter 13, “Information Technology,” requirements.
- 11.1.17. Provide receptacles for clocks if required by the telecommunications system.

**11.2. Location Specific Requirements**

| Building Area         | Receptacle Type   | Notes  |
|-----------------------|---|--|
| <b>Courtrooms</b>     |   |  |
| Judge's bench         | Quadriplex outlet for general purpose, duplex outlet for computer, duplex outlet for video monitor, minimum of two duplex outlet on front of bench                | Provide UPS power for computer.  |
| Courtroom             | Duplex outlets at 20' spacing around the courtroom, dedicated duplex outlet at the entry for security equipment   |  |
| Court clerk desk      | Quadriplex outlet for general purpose, duplex outlet for computer   | Printers shall be separate for the group. Provide UPS power for computer.                      |
| Court reporter's desk | Quadriplex outlet for general purpose, duplex outlet for computer   | Provide noted devices at primary and alternate desk locations. Provide UPS power for computer. |
| Witness box           | Duplex outlet   |  |
| Jury box              | Quadriplex outlet for general purpose   | Mount on inside of jury box near the entrance  |
| Attorney tables       | Quadriplex outlet for general purpose   | Recess device in floor if necessary to accommodate layout                                      |
| Bailiff station       | Duplex outlet   |  |
| Spectator seating     | Duplex outlet at front rail on each side of the aisle   | Mount on spectator side of rail  |
| Equipment room        | Minimum of two dedicated duplex outlets for video recording and presentation equipment  |  |
| Miscellaneous         | Duplex outlets for ceiling mounted screen, fixed or movable slide projector, video monitor, video recorder, interactive white board, x-ray viewer equipment, etc. | Coordinate locations with room layout  |

| Building Area                     | Receptacle Type  | Notes  |
|-----------------------------------|--|--|
| Video arraignment                 | Minimum of two dedicated duplex outlets for video recording and presentation equipment   | Provide UPS power with standby generator backup.                       |
| <b>Court support</b>              |  |  |
| Witness waiting rooms             | Minimum of two duplex outlets  |  |
| Attorney/ Client conference       | Minimum of two duplex outlets  |  |
| Public waiting areas              | Distributed duplex outlets for general purposes and cleaning, receptacles for monitors /notification screens   |  |
| Law/jury clerk office             | Quadriplex outlet for general purpose, duplex outlet for computer, dedicated duplex outlet for printer, fax  | Provide UPS power for computer.  |
| Court reporter office             | Quadriplex outlet for general purpose, duplex outlet for computer, dedicated duplex outlet for printer, fax  | Provide UPS power for computer.  |
| Judicial conference rooms         | Distributed duplex outlets for general purposes and cleaning, projector, video monitor, video recorder, interactive white board, x-ray viewer equipment, etc.  |  |
| Jury deliberation/ assembly rooms | Distributed duplex outlets for general purposes and cleaning, projector, video monitor, video recorder, interactive white board, x-ray viewer equipment, etc.<br>Dedicated outlets for coffee machine, microwave |  |
| <b>Judicial Chambers</b>          |  |  |
| Judge's chambers                  | Two quadriplex outlets for general purpose, duplex outlet for computer, dedicated duplex outlet for printer, fax at desk area, general purpose duplex outlets at 15' on center around office                     | Allow for two possible desk locations. Provide UPS power for computer. |
| Judicial assistant                | Quadriplex outlet for general purpose, duplex outlet for computer, dedicated duplex outlet   | Provide UPS power for computer.  |



| Building Area                       | Receptacle Type   | Notes  |
|-------------------------------------|---|--|
|                                     | for printer, fax  |  |
| Work area/kitchenette               | Dedicated outlets for coffee machine, microwave, refrigerator, copier, etc.   |  |
| Reference/<br>conference area       | Distributed duplex outlets for general purposes and cleaning, projector, video monitor, video recorder, interactive white board, x-ray viewer equipment, etc. |  |
| <b>Law Library</b>                  |   |  |
| Circulation Desk                    | Quadriplex outlet for general purpose, duplex outlet for computer   |  |
| Public waiting area                 | Distributed duplex outlets for general purposes and cleaning  |  |
| Entry control                       | Distributed duplex outlets for general purposes and cleaning, dedicated duplex outlet for security equipment  | Recess device in floor if necessary to accommodate layout. Provide UPS power for security equipment. |
| Staff offices                       | Quadriplex outlet for general purpose, duplex outlet for computer, dedicated duplex outlet for printer, fax   |  |
| Staff work areas                    | Distributed duplex outlets for general purposes and cleaning, dedicated duplex outlet for copier  |  |
| Carrel/casual seating areas         | Distributed duplex outlets for general purposes and cleaning  |  |
| Conference/ group study/ work rooms | Distributed duplex outlets for general purposes and cleaning, projector, video monitor, video recorder, interactive white board, x-ray viewer equipment, etc. |  |
| <b>Clerk of Courts Areas</b>        |   |  |
| Counter workstation                 | For each workstation, provide a quadriplex outlet for general purpose, duplex outlet for computer, dedicated duplex outlet for printer, fax. Provide          | Provide UPS power for computer.  |

| Building Area                   | Receptacle Type  | Notes   |
|---------------------------------|--|---|
|                                 | additional duplex outlets for cash registers, additional printers, copier.   |   |
| Public waiting/document viewing | Dedicated duplex outlets for public access computer, printers, and copiers.  |   |
| Staff offices                   | Quadriplex outlet for general purpose, duplex outlet for computer, dedicated duplex outlet for printer, fax  |   |
| Break room/kitchenette          | Dedicated outlets for coffee machine, microwave, refrigerator, copier, etc.  |   |
| <b>Law Enforcement</b>          |  |   |
| Booking station                 | Quadriplex outlet for general purpose, duplex outlet for computer, dedicated duplex outlet for printer   | Provide UPS power for computer.   |
| Central control work station    | Quadriplex outlet for general purpose, duplex outlet for computer, dedicated duplex outlet for security system, intercom station, interlocked hardware, etc. | Provide UPS and emergency generator power for all equipment other than general purpose outlet. Floor outlets are permitted. |
| Command center                  | Quadriplex outlet for general purpose, duplex outlet for computer, dedicated duplex outlet for printer   | Provide UPS and emergency generator power for all equipment other than general purpose outlet.                              |
| Copy/Work room                  | Dedicated duplex outlet for each copier, printer, fax  |   |
| Inmate property storage area    | Quadriplex outlet for general purpose, duplex outlet for computer  | Provide UPS power for computer.   |
| Reception area                  | Quadriplex outlet for general purpose, duplex outlet for computer, dedicated duplex outlet for printer   | Provide UPS power for computer.   |
| Release station                 | Quadriplex outlet for general purpose, duplex outlet for computer, dedicated duplex outlet   | Provide UPS power for computer.   |

| Building Area          | Receptacle Type   | Notes   |
|------------------------|---|---|
|                        | for printer   |   |
| Staff offices          | Quadriplex outlet for general purpose, duplex outlet for computer, dedicated duplex outlet for printer, fax | Provide UPS power for computer.                         |
| Transportation station | Quadriplex outlet for general purpose, duplex outlet for computer, dedicated duplex outlet for printer      | Provide UPS power for computer.                         |
| <b>911 Call Center</b> |   |   |
| Telephone station      | Quadriplex outlet for general purpose, duplex outlet for computer, dedicated duplex outlet for printer      | Provide UPS and emergency generator power for computer. |

**11.3. Additional Requirements**

- 11.3.1. All circuits serving sleeping areas shall be provided with arc-fault circuit interrupter protection.
- 11.3.2. Receptacles within 6 feet of a sink, water source, exterior door, or other water source shall be GFCI protected. Feed-through protection is not acceptable.
- 11.3.3. Exterior receptacles shall be GFCI rated with metallic weatherproof-while-in-use covers.
- 11.3.4. Receptacles for washing machines, vending machines, electric water coolers, and refrigerators shall be fed by GFCI rated receptacles or breakers. In locations where receptacle access may be difficult, GFCI breakers are preferred.
- 11.3.5. Receptacles within the medical areas, such as first aid, an emergency room, etc., shall be hospital grade and fed by the generator.
- 11.3.6. Receptacles on emergency generator power shall be red.
- 11.3.7. Receptacles on standby generator power shall be green.
- 11.3.8. Receptacles on UPS power shall be blue.

**11.4. Specifications**

- 11.4.1. Specify a 20-amp receptacle rating, minimum.
- 11.4.2. Use heavy-duty type.
- 11.4.3. Inmate area receptacles shall be 20-amp, hospital grade with tamperproof screws.

11.4.4. Cover plates shall be 0.040-inch smooth metal, except in the kitchens and restrooms, where cover plates shall be 0.302-inch stainless steel.

11.4.5. Receptacles located in common areas, such as corridors, dayrooms, cafeterias, etc., shall be high-abuse type.

### 11.5. Quantity

11.5.1. Provide for a maximum of four computers per 20-amp circuit.

11.5.2. Provide a maximum of six general-purpose receptacles per circuit.

11.5.3. Dedicated circuits shall be provided for the following:

- Equipment with a large load
- Specialty equipment (freezer, refrigerator, public address system, fire alarm, security, elevator equipment, etc.)

11.5.4. Systems furniture requirements shall be coordinated with the equipment to be provided. Allow for a minimum of one computer and two general purpose receptacles per work station.

### 11040-12. Light Switches

12.1. Specify heavy-duty type switches with nylon fronts and backs.

12.2. Switches located in common areas, such as corridors, cafeteria, etc., shall be keyed switches.

### 11040-13. Calculations

#### 13.1. Voltage Drop

13.1.1. Provide calculations with enough information to review the method of calculation.

13.1.2. Calculate voltage drop including the potential full load of panelboards and transformers and 80% of the breaker ratings for individual circuits.

13.1.3. Provide voltage-drop calculations for the following:

- Panelboards more than 100 feet from the point of distribution
- 120-volt receptacle, lighting, motor, etc., circuits more than 100 feet long
- 277-volt lighting, motor, etc., circuits more than 200 feet long
- Maximum drop:
  - 2 percent to distribution equipment
  - 3 percent from distribution equipment to device

#### 13.2. Short-Circuit Study

13.2.1. During design, the electrical Designer of Record shall provide a short-circuit study based on the available fault current from the utility company,

the service transformer impedance, and the selected electrical equipment. The study shall include all portions of the electrical distribution system, from the normal and alternate sources of power throughout the low-voltage (120/208-volt, 3-phase, 4-wire) distribution system. Normal system operating method, alternate operation, and operations that could result in maximum fault conditions shall be thoroughly covered in the study.

**13.2.2.** After award of the contract, the contractor shall provide a short-circuit study based on the actual equipment to be provided and shall meet the requirements stated above. The short-circuit study shall be completed within four months after the award of the electrical contract.

**13.2.3.** Provide equipment bracing per short-circuit study.

### **13.3. Coordination Study**

**13.3.1.** During design, the electrical Designer of Record shall provide a coordination study based on the selected electrical equipment. The study shall be provided to check the selections of breaker-trip characteristics and settings in relation to upstream and downstream circuit breaker characteristics and settings. The study shall include all voltage classes of equipment, from the utility primary over current protection to the MDP and down to and including each MCC and/or panelboard and the phase and ground overcurrent protection.

**13.3.2.** After award of contract, the contractor shall provide a coordination study based on the actual equipment to be provided and shall meet the requirements stated above. The coordination study shall be completed within four months after the award of the electrical contract.

**13.3.3.** The contractor, commissioning agent, or testing firm shall set all circuit breakers in accordance with the coordination study after the settings have been reviewed by the engineer. The contractor shall test the accuracy of these settings and the functionality of the circuit breakers.

### **13.4. Arc-flash Study**

**13.4.1.** During design, the electrical Designer of Record shall provide an arc-flash study based on the selected electrical equipment. The study shall be provided to check the hazard category of the equipment. The study shall include all voltage classes of equipment, from the MDP down to and including each MCC and/or panelboard.

**13.4.2.** After award of contract, the contractor shall provide an arc-flash study based on the actual equipment to be provided and shall meet the requirements stated above. The arc-flash study shall be completed within four months after the award of the electrical contract.

**13.4.3.** At the completion of the project, the contractor shall install UV stabilized arc-flash stickers on all equipment included in the study.

**11040-14. Kitchen Requirements**

- 14.1.** Coordinate equipment power shutdown requirements for the fire protection system as needed to meet code requirements. Ensure the shutdown circuit properly resets after a power outage.

**11040-15. Hazardous Locations**

- 15.1.** Receptacles located in workrooms and vehicle maintenance areas shall be mounted 4 feet above finished floor (AFF).

**11040-16. Cathodic Protection**

- 16.1.** Design of cathodic protection shall be performed by an engineer licensed in corrosion engineering or a specialist certified by NACE International. The designer shall have a minimum of five years' experience in similar installations and shall provide a single, coordinated design for all components requiring protection.

- 16.1.1.** In addition to providing the design, the specialist shall be required to supervise the installation and testing of the cathodic protection system for compliance with the developed requirements.

- 16.2.** Where the soil resistivity is 10,000 ohm-cm or less, a magnesium sacrificial anode or impressed current cathodic protection system shall be provided for the following:

- Metal water tanks, interior and exterior
- Underground metal piping, including water, gas, fuel, and fire suppression
- Metal lift stations
- Treatment plant components in contact with earth or water
- Structural components such as rebar, etc.
- Any metals located in soil or water

- 16.3.** Resistivity data shall be obtained from the soils or foundation report and provided to the cathodic system designer.

- 16.4.** Conduct current requirements test.

- 16.5.** Construction drawings and specifications shall show the extent of the facilities to be protected, the type of equipment required, location of installation for the equipment, location of test points, and details to provide a complete system. These documents shall include the complete design for the purchase and installation of a fully operational system.

- 16.6.** Provide sufficient corrosion control test stations to provide proper monitoring of the system.

- 16.7.** The cathodic protection system shall be designed to provide a minimum of 25 years of continuous protection.

**11040-17. Equipment Labeling**

**17.1.** Switchboards, panelboards, disconnect switches, transformers, starters, and other special distribution equipment shall be provided with the following:

**17.1.1.** Engraved plastic labels:

- White letters on black background.
- Minimum text height of 1/4 inch.
- Attach the label with screws or rivets. Pressure adhesives are not acceptable.

**17.1.2.** Identification to be provided on engraved labels:

- Indicate equipment name as shown on the electrical drawings.
- Indicate voltage.
- Indicate single or 3-phase.
- Indicate amperage.
- Indicate AIC rating.
- Indicate where the equipment is fed from.

**17.1.3.** Provide labeling for arc flash warning requirements.

**17.1.4.** Mount the label on the front of equipment. Labels shall *not* be located behind doors or covers.

**17.2.** Typed panel schedules shall be provided for record within each panelboard and shall indicate all of the equipment called out on the panelboard label as well as the individual circuiting information.

**17.2.1.** Provide room numbers with panel schedule circuiting information based upon the final facility numbering system.

**17.3.** Provide a laminated and framed as-built copy of the one-line diagram mounted on the wall of the main electrical room.

**17.4.** Junction boxes shall be labeled with the contents of the box on the front cover in concealed spaces or utility spaces, and on the inside cover in finished areas with exposed conduit. The labeling shall be made with permanent ink and shall include the panelboard name and circuit numbers.

**17.5.** All cover plates, junction boxes, load centers, panelboards, safety switches, etc., associated with *emergency* power shall be painted red in concealed and exposed locations. Standby power shall be labeled similar to normal power.

**17.6.** All fire alarm system junction boxes, raceways, switches, etc., shall be red.

**17.7.** Cover plates: All receptacles and toggle switches shall indicate the panelboard and circuit number of the device on the front of the cover plate.

- 17.7.1. Clearly label all devices and assemblies with adhesive identification tape, giving panel identification and branch circuit number.
- 17.7.2. Exterior device and assembly locations shall utilize nonadhesive aluminum tape labels fastened to the device.
- 17.7.3. Text shall be black on clear tape, where possible, with a minimum text height of 3/32 inch. Provide white letters on clear tape for black, brown, or other dark colored cover plates.
- 17.7.4. Provide a label indicating computer, printer, copier, or UPS power on the cover plate of devices intended for such use.

**11040-18. Housekeeping Pads**

- 18.1. Housekeeping pads shall be provided for all major floor-mounted equipment such as MDPs, switchgear, transformers, generators, etc.
- 18.2. Pads shall be of 3½- to 4-inch-thick reinforced concrete and shall extend a minimum of 4 inches in each direction beyond the equipment to be supported.
- 18.3. Provide conduit windows in the housekeeping pad as appropriate to the equipment to be supported.

**11040-19. Fuse Cabinet**

- 19.1. Provide a fuse cabinet within the main electrical room to store spare fuses.
- 19.2. Provide three spare fuses for each fuse size installed and store them in the fuse cabinet. Size the fuse cabinet to hold all required fuses noted.



**11050-1. General**

- 1.1. Provide a complete grounding system for all distribution and branch systems.

**11050-2. Main Distribution Panel Grounding**

- 2.1. Connect the main distribution panel (MDP) to a ground bar located in the main electrical room or MDP.
- 2.2. The system bonding jumper shall be provided at the MDP or service entrance panel and *not* at the utility transformer.
- 2.3. Bond the main electrical room ground bar (MEGB) to the following, at a minimum:
  - 2.3.1. Structural steel.
  - 2.3.2. Cold water piping.
  - 2.3.3. Concrete foundation reinforcing (where available).
  - 2.3.4. Ground rod(s).
    - 2.3.4.1. Ground rods shall consist of a 3/4-inch by 10-foot-0-inch copper-clad steel rod.
    - 2.3.4.2. Drive ground rods until tops are 2 inches below finished floor or final grade, unless otherwise indicated.
    - 2.3.4.3. Inspection wells for ground rods shall be nonmetallic with a nonmetallic cover, minimum thickness 1/2 inch, with a bolt to hold the cover in place.
    - 2.3.4.4. Connections to ground rods shall be made with exothermic welds where not in inspection wells.
  - 2.3.5. Ground Ring
    - 2.3.5.1. Ground the steel framework of the building with a driven ground rod at the base of every corner column and at intermediate exterior columns at distances of not more than 60 feet. Provide a ground ring conductor, electrically connected to each ground rod and to each steel column, extending around the perimeter of the building. Use tinned-copper conductor not less than number 4/0 AWG for the counterpoise and for the tap to building steel. Bury the counterpoise not less than 36 inches below grade and ten feet from the building foundation.
    - 2.3.5.2. Bond the ground ring to the main electrical room ground bar with two number 4/0 cables in conduit.
  - 2.3.6. Ground each above-ground portion of the gas piping system upstream from the equipment shutoff valve.
  - 2.3.7. Lightning protection system:

- 2.3.7.1. Bond the MDP ground to the lightning protection system grounding conductor at the closest point to the electrical service grounding electrode. Bond the lightning protection system to the distribution system at only one location. Use a bonding conductor sized the same as the system grounding electrode conductor and install in conduit.
- 2.3.7.2. Refer to Section 11120, "Lightning Protection," for additional information.
- 2.3.8. Telecommunications room ground bar(s) (TGB) with number 4 wire, minimum. Bond each TGB to the MEGB with a dedicated ground conductor.
- 2.4. Maximum interconnected ground resistance shall be 5 ohms.
  - 2.4.1. Reports indicating actual ground resistance shall be provided to the BIA for review during construction.
  - 2.4.2. In areas of high ground resistance, provide recommendations to the BIA on methods to achieve the recommended ground resistance.
- 2.5. Building-steel and underground connections shall be made with exothermic welds.
- 2.6. Chemical electrodes shall be permitted only when approved by the BIA *in writing*.

### 11050-3. Grounded Equipment

- 3.1. Provide an equipment ground conductor in all raceways.
  - 3.1.1. Bond to all ground lugs, busses, switches, receptacles, equipment frames, etc.
  - 3.1.2. Provide a bonding jumper from the grounding screw of all receptacles to a metallic box that is mounted with a separate grounding screw or clip device.

### 11050-4. Exterior Metal Poles

- 4.1. Exterior metal poles, such as light poles, flagpoles, banners, etc., shall be provided with an equipment ground conductor *and* ground rod at each pole location.

### 11050-5. Mechanical Equipment

- 5.1. Bond interior metal piping systems and metal air ducts to equipment grounding conductors of associated pumps, fans, blowers, electric heaters, and air cleaners. Where metallic piping and duct systems are rendered metallically noncontinuous by nonconductive couplings, provide bonding jumpers to restore grounding continuity.

**11050-6. Isolated Ground**

- 6.1.** Isolated grounds shall only be provided where approved by the BIA in writing.

**11060-1. General**

- 1.1. The interior lighting system shall be designed to provide light levels suitable for the intended use of the individual spaces.
- 1.2. In no interior location shall light levels be below 15 footcandles measured at 30 inches above the floor in inmate accessible areas other than during sleeping hours.

**11060-2. Energy Performance**

- 2.1. All lighting systems shall be designed to meet or exceed the current ASHRAE 90.1 energy code requirements.
- 2.2. The lighting systems shall be designed in coordination with the daylighting design for maximum energy savings.
- 2.3. The lighting Designer of Record shall report the preliminary lighting power densities in the design analysis report and the final lighting densities to the energy modeler during the design process to determine energy code compliance and make adjustments as necessary.

**11060-3. Emergency Lighting**

- 3.1. Emergency egress lighting shall be provided by batteries. The acceptable methods for supplying emergency power to the lighting fixtures shall be considered in the following order:
  - Integral battery ballast in select fixtures
  - Stand-alone battery fixtures (wall packs)
  - Central inverter system
- 3.2. The following areas shall be provided with emergency battery backup lighting *and* emergency generator power for all lighting in the space unless noted otherwise:
  - Command and control center
  - 911 Call Center
  - Administration areas with building control panels
  - All inmate areas (egress light levels only as noted below)
  - Courtrooms (egress light levels only as noted below)
  - Judge's chambers
  - Law enforcement interview rooms
  - Attorney interview rooms
  - On the exterior of all exit doors (only one fixture required at each door)
  - Sallyports

- Areas requiring additional lighting for security purposes. Consult the BIA representative for potential areas.
- 3.3. The following areas shall be provided with emergency battery backup lighting *and standby* generator power:
- Medical rooms
  - Public reception areas
  - Squad rooms
- 3.4. Battery backup egress lighting shall be provided in the following areas:
- Locker rooms
  - Kitchens
  - Multi-stall restrooms
  - Assembly areas and rooms with an occupant load over 50
  - Conference rooms
  - Main electrical room
  - Mechanical rooms
  - Emergency power equipment location
- 3.5. Verify battery ballast lumen output specified provides an average of 1 footcandle, 0.1 footcandle minimum, in the path of egress for the public and staff areas.
- 3.6. Provide a minimum of 5 footcandles in the path of egress in inmate areas.
- 3.7. Provide a specific callout on the drawings or luminaire schedule indicating the minimum level of battery ballast lumen output.

**11060-4. Exit Signs**

- 4.1. LED exit signs shall be used with battery backup and self-testing diagnostics.
- 4.2. Exit signage shall meet the requirements of ADA and ABA.
- 4.3. Exit signage shall be provided in the following areas unless otherwise exempt by code:
- Emergency egress paths and exits
  - Interior of all exit doors
  - Assembly areas and rooms with an occupant load over 50
  - All spaces with two or more doors (even if the doors are not in the path of egress)
- 4.4. Exit signage is not required in sleeping areas per NFPA 5000 21.2.10.2.

**11060-5. Lamps**

- 5.1. The lighting for each facility should be designed to minimize the number of lamp types on the project. There should be no more than six interior lamp types for a given project.
- 5.2. Fluorescent, 4-foot T8 lamps shall be used in as many luminaires as possible.
- 5.3. Fluorescent, 4-foot T5 and T5HO lamps may be used in high-ceiling applications such as dayrooms and common areas.
- 5.4. Due to the shorter lamp life and higher lamp cost, compact fluorescent lamps shall only be used in areas where a linear 4-foot luminaire will not fit or where there are unique design considerations unless noted otherwise.
- 5.5. All fluorescent lamps shall be 4100K color temperature with a color rendering index (CRI) of 85 or higher.
- 5.6. Provide low-dose mercury lamps for all lamp types that are available in a low-dose mercury version. Low-dose mercury shall be defined as any lamp that passes the Environmental Protection Agency's Toxicity Characteristic Leaching Procedure (TCLP) test for lamps.
- 5.7. Incandescent lamps may be used where approved by the BIA in writing.
- 5.8. The minimum lamp life allowed for all incandescent lamps shall be 2,000 hours. All incandescent fixtures shall be on dimmed circuits to extend lamp life.
- 5.9. High-intensity discharge lamps shall not be used for interior lighting where ceiling heights are below 30 feet.
- 5.10. Light emitting diodes (LEDs): To reduce maintenance and energy costs, the use of LED light sources is strongly encouraged. Examples of LED light source applications could include steplights at exterior spaces, downlights, and cove lighting. As LED light output improves, other applications may be acceptable.
  - 5.10.1. Locations for LED fixtures shall be reviewed for appropriate temperature parameters affecting LED function and lamp life.

**11060-6. Ballasts**

- 6.1. Linear fluorescent lamp ballasts shall have the following characteristics:
  - 6.1.1. Ballasts shall be electronic with a minimum 5-year warranty.
  - 6.1.2. The manufacturer shall have a minimum 10-year history of making ballasts for the North American market.
  - 6.1.3. Ballasts shall not contain polychlorinated biphenyls (PCBs).
  - 6.1.4. Instant-start ballasts shall be used unless the fluorescent lighting systems are anticipated to have more than five starts per day. If the lighting systems will have more than five starts per day, programmed-start ballasts shall be used (reference NEMA LSD 18 Compatibility of Fluorescent Lamps and Electronic Ballasts in Frequent Switching Applications). Only

one type of linear fluorescent ballast (instant start or programmed start) shall be used for the entire project.

- 6.1.5. Total harmonic current distortion shall be less than 10 percent.
- 6.1.6. The power factor shall be greater than 0.98.
- 6.1.7. The ballast factor shall be greater than 0.88.
- 6.1.8. The audible noise rating shall be Class A or better.
- 6.1.9. The ballast shall support a sustained short-to-ground or open circuit of any of the output leads without damage to the ballast.
- 6.1.10. The ballast shall have a lamp current crest factor of less than 1.7.

**11060-7. Specialty Lighting**

- 7.1. Provide additional specialty lighting in the medical office consistent with the level of care to be provided.

**11060-8. Fixture Rating in Inmate Areas**

- 8.1. All light fixtures in detention areas shall be maximum security rated fixtures with tamper-proof hardware.
- 8.2. All light fixtures in waiting rooms, attorney/client rooms, and other areas where inmates may be without an escort shall be maximum security rated fixtures with tamper-proof hardware.
- 8.3. Light fixture housing steel shall be a minimum of 12 gauge.
- 8.4. Lens shall be a minimum of 0.3" thickness.

**11060-9. Ceiling Fire Rating**

- 9.1. Where a fire-rated ceiling is provided, the lighting system shall be designed as required to maintain the rating.

**11060-10. Luminaire Mounting**

- 10.1. All light fixtures shall be mounted in a secure and stable manner.
- 10.2. Where light fixtures are mounted to walkways above, coordinate the conduit routing and fixture mounting with the architect.
- 10.3. Seismic restraint requirements shall be coordinated with the individual site. Local seismic codes shall be considered the minimum requirements.

## 11060-11. Lighting Level Requirements

Figure 11060-1: Lighting Level and System Type Requirements by Room Type

| Building Area   | Luminaire Type  | Lighting Level<br>Average Maintained<br>Horizontal Footcandles<br>30 Inches Above Floor |
|---|---|---|
| Administration areas,<br>workrooms, conference<br>rooms | Fluorescent with multi-level<br>switching   | 30-45   |
| Cafeteria   | Fluorescent   | 15-20   |
| 911 Call center   | Fluorescent with multi-level<br>switching   | 30-45   |
| Classrooms/training<br>rooms                            | Suspended linear direct/indirect<br>fluorescent with multi-level<br>switching   | 30-35   |
| Command Center  | Fluorescent with multi-level<br>switching, separately switched<br>perimeter downlights  | 15-20   |
| Corridors   | Fluorescent   | 15-20   |
| Courtroom- Judge's area<br>Jury box<br>Seating area     | Suspended linear direct/indirect<br>fluorescent with multi-level<br>switching and separately<br>switched downlights at the<br>bench | 50-55   |
| Court space - Jury box                                  | Suspended linear direct/indirect<br>fluorescent with multi-level<br>switching   | 30-40   |
| Court space - Seating<br>area                           | Suspended linear direct/indirect<br>fluorescent with multi-level<br>switching   | 15-20   |
| Dayroom   | Surface mounted fluorescent   | 30-35   |
| Detention space -<br>daytime<br>Nighttime               | Surface mounted fluorescent<br>with nightlight  | 30-35<br>2-4  |
| Fitness/ activity space                                 | Fluorescent   | 20-25   |
| Interview room  | Fluorescent   | 30-35   |



| <b>Building Area</b>             | <b>Luminaire Type</b>   | <b>Lighting Level<br/>Average Maintained<br/>Horizontal Footcandles<br/>30 Inches Above Floor</b> |
|----------------------------------|---|---|
| Kitchen                          | Fluorescent with enclosed and gasketed lenses                     | 50-55   |
| Laundry                          | Fluorescent with wraparound acrylic lenses                        | 30-35   |
| Lobbies                          | Fluorescent   | 15-20   |
| Locker rooms                     | Fluorescent   | 15-20   |
| Medical -Ambient<br>Medical task | Fluorescent with multi-level switching and under-cabinet lighting | 50-55<br>300-1000   |
| Property and evidence storage    | Fluorescent with enclosed and gasketed lenses                     | 30-35   |
| Restrooms (public)               | Fluorescent   | 20 at vanity, 10 other areas  |
| Storage                          | Fluorescent with wraparound acrylic lenses                        | 10-15   |
| Sallyport                        | Fluorescent with wraparound acrylic lenses                        | 15-20   |
| Utility rooms                    | Fluorescent with wireguard  | 10-15   |
| Visitation                       | Fluorescent   | 20-25   |

**11070-1. General**

- 1.1. Exterior lighting shall be designed to minimize light pollution and light trespass while maintaining security.
- 1.2. Refer to the current LEED guidelines for specific information about requirements to qualify for the Light Pollution Reduction credit.

**11070-2. Emergency Power**

- 2.1. Perimeter lighting of the site shall be provided with emergency generator backup power.

**11070-3. Lamps**

- 3.1. Exterior wall- or canopy-mounted lights shall be triple-tube compact fluorescent or LED for emergency egress lighting.
- 3.2. Metal halide lamps shall be used for all other exterior lighting.

**11070-4. Ballasts**

- 4.1. Compact fluorescent light fixtures shall utilize electronic ballasts with a 5-year warranty and 0°F starting temperature.
- 4.2. Metal halide ballasts shall be constant-wattage type, with a minimum starting temperature of minus 40°C and with a noise rating of B or better.

**11070-5. Poles**

- 5.1. Refer to Section 11050 for grounding requirements.
- 5.2. Light poles shall be galvanized steel or steel with a corrosion-resistant powder coat painted finish.
- 5.3. For most projects, all light poles and other support structures (brackets, arms, appurtenances, bases, and anchorage and foundations) shall comply with the American Association of State Highway and Transportation Officials (AASHTO) 1994 *Specifications for Structural Supports for Highway Signs, Luminaires, and Traffic Signals*, with current interims. For project sites where unusually high winds or persistent wind conditions exist, use the AASHTO 2001 standards with current interims.
- 5.4. Light poles shall have a wind-load strength adequate at indicated heights above grade without failure, permanent deflection, or whipping in steady winds of the speed for the project site with a gust factor of 1.3.
- 5.5. Pole supports shall be reinforced concrete.
- 5.6. Locate poles to minimize potential damage from vehicles and snow removal. Poles shall be located on a landscaped island or at perimeters of parking areas wherever possible. Provide an elevated concrete foundation 36 inches above grade where poles are located in paved parking areas.

**11070-6. Pole Locations**

- 6.1.** Locate poles to avoid direct illumination upon security cameras.
- 6.2.** Locate poles to avoid direct illumination upon walls that could produce hot spots exceeding the lighting level maximum to minimum ratio.

**11070-7. Lighting Level Requirements****Figure 11070-1: Lighting Level and System Type Requirements by Exterior Area**

| <b>Exterior Building Area</b>               | <b>Luminaire Type</b>  | <b>Lighting Level<br/>Average Maintained<br/>Horizontal Footcandles<br/>at Ground, Max:Min<br/>Ratio</b> |
|---|--|--|
| Access roads                                | Pole-mounted metal halide with full cutoff optics                          | 0.6<br>10:1  |
| Building entries                            | Wall-mounted or canopy-mounted compact fluorescent with full cutoff optics | 5.0–8.0<br>10:1  |
| General grounds                             | Pole- or wall-mounted metal halide with full cutoff optics                 | 0.5<br>10:1  |
| Parking areas                               | Pole-mounted metal halide with full cutoff optics                          | 0.5 minimum<br>10:1  |
| Pedestrian path from parking to building(s) | Pole-mounted metal halide with full cutoff optics                          | 1 minimum<br>10:1  |
| Perimeter fence/ video camera view area     | Pole-mounted metal halide  | 1-3<br>4:1   |
| Vehicular sallyport                         | Pole- or wall-mounted metal halide   | 3-5, 4:1   |

**11070-8. Calculation Requirements**

- 8.1.** Provide point-by-point computer calculations for all exterior lighting, including lighting at building entrances. Point-by-point analysis shall consist of maintained horizontal illuminance at the ground with a maximum grid spacing of 10 feet by 10 feet for parking areas and 5 feet by 5 feet for entry areas.

**11070-9. Exterior Lighting Control – ASHRAE 90.1 Requirements**

- 9.1.** Exterior lighting shall be controlled via a photocell and time switch combination. Non-security lighting shall be turned off after normal operating hours via a building automation system time switch or via an electromechanical time clock in cases where a building automation system is unavailable.

**11080-1. General**

- 1.1. Projects that have a direct digital control (DDC) system shall use the building automation time clock for after-hours automatic control of the lighting systems. Photocell controls shall be used for site lighting and daylight harvesting of interior lighting.

**11080-2. ASHRAE 90.1 Requirements**

- 2.1. All lighting control systems shall conform to ASHRAE 90.1 requirements. These requirements include automatic means for turning off lighting after normal operating hours. Building automation system time switch and wall switch–type occupancy sensors may be used.

**11080-3. Switches**

- 3.1. Specify heavy-duty type switches with nylon fronts and backs.
- 3.2. Switches located in common areas, such as corridors, cafeteria, etc., shall be keyed switches.

**11080-4. Occupancy Sensors**

- 4.1. Occupancy sensors shall not be installed in inmate accessible areas.
- 4.2. Occupancy sensors shall be used in the following types of spaces with the technology type and mounting indicated:

**Figure 11080-1: Occupancy Sensor Requirements**

| Room Type   | Sensor Type | Mounting   |
|---|-------------|--|
| Small storage rooms                                   | Infrared    | Wall switch type   |
| Conference rooms<br>Work rooms<br>Large storage rooms | Infrared    | Wall mounted if pendant lighting is used<br>Ceiling mounted if recessed lighting is used |
| Restrooms   | Ultrasonic  | Ceiling mounted  |

- 4.3. Specify sensors with appropriate coverage patterns for each space. Locate sensors to avoid false “on” tripping due to open doorways or vibrations created by other building systems. Set all sensor time delays to 30 minutes.

**11080-5. Time Switches**

- 5.1. Individual time switches may be used if the building does not have a building automation system. These time switches shall have the following functions:
  - Electromechanical-dial type complying with UL 917

- Astronomic dial
- 20-amp contact rating
- Manual hand-off-auto switch
- Timing motor – heavy-duty synchronous, 16-hour reserve power

**11080-6. Lighting Contactors**

- 6.1.** Lighting contactors shall be used if they are controlled via electromechanical time switch.

**11080-7. Relay Panels**

- 7.1.** Relay panels shall be utilized for lighting control for all inmate accessible areas.
- 7.2.** Relay panels shall be configured to provide sweep off function for the following zones:
- 7.2.1.** Sleeping areas, ambient lighting.
  - 7.2.2.** Sleeping areas, night lighting.
  - 7.2.3.** Dayroom.
  - 7.2.4.** Ancillary spaces with inmate access.

**11090-1. General**

- 1.1. In the course of any building project, additional requirements for power and conduits arise based on the needs of other disciplines and specialty equipment. In assessing power requirements, be sure that coordination between all other disciplines has occurred, all equipment is taken into consideration, and that all necessary power and conduit connections are provided.
- 1.2. Some commonly missed coordination items are listed below. This list is not intended to be complete nor is it intended to be in lieu of project-specific coordination.

**11090-2. Conduit**

- 2.1.1. Refer to Section 11040 for additional information.

**11090-3. Communications**

- 3.1. Provide dedicated power to sound systems, such as:
  - 3.1.1. Public address system.
  - 3.1.2. Dayroom sound systems. The dayroom sound systems shall be interlocked with the fire alarm system to shut down the local sound system upon fire alarm activation.
  - 3.1.3. Telephone/intercom system.
    - 3.1.3.1. Provide junction boxes for connection to rack mounted receptacles in telecom rooms.
  - 3.1.4. Clock system and clocks.

**11090-4. Security**

- 4.1. Provide power to the following items where applicable:
  - Burglar alarm panel via a dedicated circuit
  - Electric door strike and associated power packs
  - Magnetic door locks and associated power packs
  - Security cameras requiring power
  - Security monitoring equipment, i.e., video monitors, recording equipment, etc., via a dedicated circuit
  - Repeater range extender
- 4.2. Coordinate interface between security requirements and door release functions for the fire alarm system.

**11090-5. Architectural Equipment**

- 5.1. Coordinate power and/or lighting requirements to site signage.
- 5.2. Coordinate motorized door locations and requirements.

- 5.3. Coordinate ADA/ABA door opener locations.
- 5.4. Coordinate electric water cooler locations and requirements.
- 5.5. Coordinate ceiling-mounted projector locations and requirements.
- 5.6. Verify special power requirements for video conferencing.
- 5.7. Coordinate motorized screen and blackout shade requirements.

**11090-6. Irrigation**

- 6.1. Provide a power connection to the irrigation controller.
- 6.2. Provide power to the irrigation fertilizer pump system.
- 6.3. Provide a convenience receptacle at the grounds maintenance shed.

**11090-7. Miscellaneous**

- 7.1. Coordinate power requirements for any miscellaneous facility equipment such as radio towers, guard shacks, etc.



**11100-1. General**

- 1.1. Fire alarm systems and installation shall comply with NFPA 5000, NFPA 72, ADA, and ABA requirements for the number and placement of devices.
- 1.2. Refer to Section 11020, “Codes, Standards, and Laws,” for additional code compliance requirements for fire alarm systems.
- 1.3. The fire alarm system shall be provided with Class A wiring, 14 gauge, minimum.
- 1.4. The specifications for the fire alarm system shall be performance based. It shall be the responsibility of the engineer who develops the shop drawings to provide a fully code-compliant design and installation.
- 1.5. Device locations shall be indicated on the construction plans *and* shop drawings.
- 1.6. Submittals shall include the following:
  - 1.6.1. Shop drawings shall be signed and stamped by a registered professional engineer or fire protection engineer for the state in which the project is to be constructed.
  - 1.6.2. Battery calculations.
  - 1.6.3. Voltage drop calculations.
  - 1.6.4. Catalog data sheets.
  - 1.6.5. Floor plans with actual device locations, device addresses, and routings of raceway connections.
  - 1.6.6. A detailed description for the project, including method of operation and supervision for each type of circuit and sequence of operations for manually and automatically initiated system inputs and outputs. Manufacturers’ standard descriptions for generic systems are not acceptable.
  - 1.6.7. A complete list of device addresses and corresponding messages.
  - 1.6.8. A detailed wiring diagram differentiating between manufacturer-installed and field-installed wiring. Include diagrams for equipment and for systems that are supervised or controlled by the fire alarm control panel (FACP), with all terminals and interconnections identified. Diagrams shall show all connections from field devices to the FACP and remote fire alarm control units, initiating circuits, switches, relays, and terminals. Provide point-to-point wiring diagrams showing all internal panel wiring connections and jumper positions.
  - 1.6.9. A full-size drawing of the graphic map at the size to be provided.
- 1.7. Provide at least 25 percent spare capacity for notification appliances and 25 percent spare capacity for initiating devices.

- 1.8. The fire alarm system shall be a separate, stand-alone system and shall *not* be based on the telecommunication system or servers.
- 1.9. Verify if smoke control is required. When required, provide uninterruptible power supply (UPS) and emergency generator power for smoke control equipment.

**11100-2. Where Required**

- 2.1. Provide a fire alarm system for all institutional buildings.
  - 2.1.1. This includes justice and detention facilities, kitchen/dining areas, etc.
  - 2.1.2. Excluded buildings shall include dwellings, storage buildings (not including hazardous storage), and well water buildings unless a fire alarm system is specifically required by code or requested by the Contracting Officer.
  - 2.1.3. Each building shall have a separate, stand-alone fire alarm system where required.

**11100-3. Fire Alarm Control Panel**

- 3.1. The FACP shall be a noncoded, addressable-analog system with manual and automatic alarm initiation and multiplexed signal transmission dedicated to fire alarm service only. All automatic and manual initiating devices shall be the addressable type.
  - 3.1.1. Zoned systems are not acceptable.
  - 3.1.2. The FACP shall display a minimum of 80 characters; alarm, supervisory, and component status messages; and shall indicate control commands to be entered into the system for control of smoke detector sensitivity and other parameters. A backlit display shall be provided upon failure of the normal power source.
  - 3.1.3. A keypad shall be provided to permit entry and execution of programming, display, and control commands.
  - 3.1.4. The FACP shall control elevator recall/shunting, door hold-opens, dampers, fan shutdown, smoke control, etc., as necessary to accommodate the requirements for the specific site.
  - 3.1.5. A “trouble reminder” feature shall be included with an adjustable time setting.
- 3.2. Power to the FACP shall be provided via a dedicated circuit with a key-lockable breaker.
- 3.3. The FACP shall be provided with battery backup power per NEC 72 requirements.
  - 3.3.1. The battery shall be a nickel-cadmium type with charger and an automatic transfer switch.

- 3.3.2.** Battery nominal life expectancy shall be 10 years, minimum.
- 3.4.** When available, the FACP shall be backed up by the emergency or standby generator *and* the battery system.
- 3.5.** The FACP shall be provided with an automatic telephone dialer, radio transmitter, digital communicator, or other approved means as specified by the BIA, to notify a remote monitoring station, the local fire station, or an independent monitoring facility.
- 3.5.1.** The remote monitoring entity shall be determined during the Schematic Design phase of the project.
- 3.6.** The FACP shall be located in the control room or as designated by the BIA.
- 3.7.** The FACP shall be capable of accommodating on-site minor additions or deletions to the system with no additional hardware or software required.
- 3.8.** Software in the FACP shall be stored in a nonvolatile memory configuration such that programming information is *not* lost upon loss of power.
- 3.9.** The FACP shall incorporate flexible input/output control functions based on AND, OR, NOT, timing, and special code operations.
- 3.10.** The FACP shall be able to recall alarms and trouble conditions in chronological order to recreate an event history. A minimum of 50 event recordings shall be required.
- 3.11.** A separate designation shall be provided for each HVAC unit associated with the fire alarm system.
- 3.12.** An annunciator shall be provided at each main entry and where otherwise required by code. The annunciator shall duplicate functions of the FACP for alarm, supervisory, and trouble indications, and shall provide manual switching functions of the FACP, including acknowledging, silencing, reset, and test.
- 3.13.** A nonilluminated graphic map shall be provided at the FACP and each annunciator location.
- 3.14.** Where required, provide voice annunciation, fire phones, radio booster, smoke control, emergency messaging, fire pump monitoring, pre-action systems, agent release systems, alarm verification, or other special fire alarm requirements as coordinated with the project-specific requirements and code compliance.

#### **11100-4. Manual Pull Stations**

- 4.1.** Provide double-action equipment with an indoor protective shield hinged at the top to permit lifting for access to initiate an alarm.
- 4.2.** Lifting the shield shall actuate an integral battery-powered 85-decibel horn intended to discourage false alarm operation.
- 4.3.** Locate pull stations per code requirements, but not less than at every exit, every 200 feet, and on every level, except as specifically noted otherwise.

- 4.3.1.1. Do not locate pull stations in inmate areas unless the pull station is locked, the staff is present within the subject area when occupied, and staff has keys readily available to unlock the boxes.
- 4.3.1.2. Pull stations shall be permitted to be located in a staff location rather than an inmate accessible path of egress, provided that the staff location is attended when the building is occupied and that the staff attendant has direct supervision of the sleeping area.
- 4.4. Provide an additional pull station at each exit from a kitchen or break room.

#### 11100-5. Detection

- 5.1. Provide detection for select areas only as required to meet code requirements.
  - 5.1.1. Provide detection at the FACP, in elevator lobbies, in elevator shafts, in elevator machine rooms, at doors between areas of separation, for smoke-activated fire alarm functions, etc., as necessary to meet code requirements.
  - 5.1.2. Provide detection below raised floors. Detectors shall be rated for the air velocities present.
  - 5.1.3. Coordinate detector locations for inmate sleeping areas with the parameters of the building.
    - 5.1.3.1. If possible, provide detection in the corridor outside of sleeping areas. Verify the ceiling configuration will provide appropriate detection and does not have obstructions or ceiling height changes that prohibit smoke transfer to the corridor.
    - 5.1.3.2. If detectors are located in the cells, a wireguard suitable for maximum security shall be provided around the detector.
    - 5.1.3.3. If detectors cannot be located in the corridors or cells, provide return air path duct detectors. Coordinate the exact location of the duct detector with the mechanical design to ensure that there is sufficient accessible duct space or length to support the duct detector installation.

#### 5.2. Duct Detectors

- 5.2.1. Provide duct detectors in supply *and* return ducts for air handling units (AHUs) with air velocities of 2,000 cubic feet per minute or greater.
- 5.2.2. Ensure that duct detectors are located prior to any duct splits, or provide a duct detector on each branch of duct work where required for complete coverage.
- 5.2.3. Remote indicating lights and keyed test switches shall be provided for each duct detector.
  - 5.2.3.1. Locate the test switch in the nearest corridor or other common space, wall mounted at 7 feet 0 inches above finished floor (AFF). Provide

a permanent label indicating which unit the duct detector is protecting.

- 5.2.3.2. When a duct detector is concealed above a ceiling, provide a permanent label on the access door or the ceiling tile used for service access to the duct detector, indicating which duct detector is at that location.
- 5.2.4. Provide a detector within 5 feet of each smoke damper.
- 5.2.5. Activation of a duct detector shall shut down the associated AHU.
- 5.2.6. Manual override shall be provided for testing of AHU shutdown upon duct detector activation.

### 5.3. Smoke and Heat Detectors

#### 5.3.1. Required detector locations:

- 5.3.1.1. Locate detectors at least 5 feet from supply air grilles.
- 5.3.1.2. Locate detectors at least 12 inches from lights.
- 5.3.1.3. Consider stratification effects when selecting detector locations.
- 5.3.1.4. Where required by paragraph 5.1 above, heat detectors shall be provided for any kitchen, boiler room, main electrical room, or other location where dirt or debris are likely to cause false alarms.
- 5.3.1.5. Heat detectors shall be intermediate fixed temperature rated.

### 11100-6. Notification

#### 6.1. Horns/Speakers

- 6.1.1. Provide a sufficient number of horns/speakers spaced per NFPA 72 requirements.
- 6.1.2. Provide horns/speakers as required by code and in each corridor, cafeteria, mechanical room, break room, and soundproof room.
- 6.1.3. Where required by code, provide either live or pre-recorded voice announcements for mass notification via speakers.
- 6.1.4. Where mass notification is required for one room of a building, provided speakers for mass notification throughout the building if necessary to avoid audible horn sounders within mass notification areas.
- 6.1.5. Where a cafeteria, etc., has a local sound system, provide the means to disengage the sound system upon activation of the fire alarm system and initiate a pre-recorded voice announcement. Provide a local override to allow for live announcements. The override shall time out and resume the pre-recorded message within 10 seconds after the end of the live message.

**6.2. Strobes**

**6.2.1.** The candela level provided by the strobes shall be coordinated with the application and location as required to meet NFPA 72 requirements.

**6.2.2.** Provide strobes as required by code and in each corridor, cafeteria, mechanical room, break room, soundproof room, conference room, training room, restroom, etc.

**6.3.** Provide separate circuits to the horns and strobes to enable separate horn/speaker silence features.

**6.4.** Provide audible/visual notification within 15 feet of all exits.

**6.5.** Provide an exterior weatherproof horn/strobe at the fire department Siamese connection or at the point of entry of the fire department where a Siamese connection is not installed.

**6.6.** Provide two-way communication between areas of refuge and the FACP.

**6.7.** Provide illuminated signage indicating areas of refuge.

**11100-7. Remote Annunciator**

**7.1.** Provide a remote annunciator indicating fire alarm status located in the administration area or other location requested by the BIA.

**11100-8. Monitored Equipment**

**8.1.** As a minimum, the following additional equipment shall be monitored by the FACP. Activation of the monitored equipment shall create an alarm or trouble condition as required by code.

- The kitchen hood fire protection system
- Main building and elevator dedicated flow and tamper switches

**11100-9. Elevator Recall/Shunt**

**9.1.** Provide an integral relay capable of sending a direct signal to initiate a control device, for instance to an elevator controller to initiate elevator recall, or to a circuit-breaker shunt trip for power shutdown.

**11100-10. Magnetic Door Hold-Opens**

**10.1.** Configure door hold-opens to close upon any fire alarm.

**10.2.** Coordinate voltage requirements for magnetic door hold-opens.

**10.3.** Coordinate door hold-opens with security requirements.

**11100-11. Riser Diagram**

**11.1.** Riser diagrams for the fire alarm system shall indicate the following as a minimum:

- FACP

- Annunciator(s)
- Separate circuits to horns and strobes
- The automatic dialer, digital communicator, or radio transmitter
- HVAC equipment requiring shutdown
- Smoke and heat detectors
- Manual pull stations
- Duct detectors and the associated remote indicating lights and test switches
- Flow and tamper switches
- Kitchen hood fire suppression equipment
- Risers and loops
- Voice communication (where necessary)
- Power source
- Door hold-opens
- Other equipment necessary for a complete installation

**11.2.** Riser diagrams shall indicate the room numbers associated with the panels and devices on the diagram.

#### **11100-12. Protection**

**12.1.** Provide wireguards with 0.125-inch wire, minimum, for fire alarm equipment located in gymnasiums, locker rooms, and other areas where damage to the equipment is likely.

**12.2.** All devices to be installed shall be tamper-resistant, where possible.

**12.3.** Provide maximum security rated protection for all fire alarm components in inmate contact areas.

#### **11100-13. Special Requirements**

**13.1.** Where directed by the BIA, provide special equipment as required by the NFPA for the visually and hearing impaired.

**11110-1. General**

- 1.1. To meet life safety requirements, emergency power is required for all BIA justice/detention facilities.
- 1.2. Coordinate emergency power requirements for each location with the BIA.
- 1.3. Provide a single generator with multiple transfer switches to support emergency and standby power.
- 1.4. Emergency and normal power distribution equipment and panelboards shall be installed as far apart as is feasible with a minimum of 50' of separation.

**11110-2. Required Generator Power**

- 2.1. Standby generator power shall be provided to support the entire facility where utility reliability is low or loss of power for extended periods would cause hardship to the facility.
- 2.2. Justice/detention facilities that are to be used as recovery facilities after natural disasters shall be provided with standby generators to cover the entire facility. Coordinate with the BIA to determine if the new building is to serve this purpose, and if so, what area(s) of the building will be used.
- 2.3. The electrical Designer of Record shall perform an analysis of the utility service as noted in this section and in Section 11030, "Exterior Utilities," and shall provide a recommendation to the BIA as to whether or not the generator shall support the entire facility.
- 2.4. The BIA will review the analysis and recommendations and approve or disapprove the inclusion of a generator for the entire facility.

**11110-3. Generator Sizing**

- 3.1. At a minimum, the generator shall be sized to support the following loads:
  - Lighting as described in sections 11060 and 11070.
  - Equipment as noted in section 11040.
  - Elevator(s), one public and one secure.
  - Security alarm system(s).
  - Electric power–operated sliding doors and electric power–operated locks for detention cells.
  - CCTV system(s).
  - Fire alarm system.
  - Public address system.
  - Intercom system.
  - Telephone system.
  - Computer server system.
  - UPS systems for computers.



- Air conditioning (primary and backup) for the communications and computer rooms.
- Ventilation system.
- Mechanical controls.
- Kitchen freezers and refrigerators. (Does not include kitchenettes.)
- Food preparation power.
- Boiler(s).
- Water circulating pump(s).
- Fire pump. Verify that the starting voltage drop is within the fire pump parameters.
- Sewage pump(s).
- 10% space capacity.

**11110-4. Generator Installation**

- 4.1. Generators shall be installed outdoors wherever possible. The location shall not be accessible to inmates.
- 4.2. Indoor installations require special provisions, such as combustion air, exhaust, ventilation, and a 2-hour fire-rated room with a minimum of 3 feet clearance around the generator. Coordinate requirements with the BIA prior to selecting an indoor installation.

**11110-5. Generator Connection Point**

- 5.1. Where budget and other factors prohibit the installation of a generator to support the entire facility, consideration shall be given to providing a “plug-in” location for a portable generator, such as a manual transfer switch located in an easily accessible location, for standby power. Separation of standby and emergency loads would be necessary under this scenario to prevent paralleling the generators.

**11110-6. Generator Requirements****6.1. Fuel Source**

- 6.1.1. Natural gas is the preferred fuel source for generators below 100kW in size. Verify with the gas utility that the gas supply is classified as an “uninterruptible” service. If not, a second fuel source is required for emergency natural gas generators.
- 6.1.2. The first choice for an alternate fuel source is diesel, followed by propane.
- 6.1.3. Coordinate the fuel source with the BIA prior to final selection.
- 6.2. The minimum run time for the generator shall be 90 minutes. Increase the run time as appropriate to accommodate the utility power reliability.
- 6.3. The required regular generator testing shall be performed under actual load conditions. A load bank shall not be provided.

6.4. Parallel generators shall not be permitted.

6.5. The muffler shall be critical grade.

**6.6. Alarms**

6.6.1. Generator alarms and monitoring equipment shall notify to the Building Automation System.

**6.6.2.**

**11110-7. Automatic Transfer Switches**

7.1. Provide separate automatic transfer switches (ATS) to the emergency power, the fire pump, the emergency ventilation system, and the standby power distribution.

7.2. The ATS shall have an adjustable exercise clock adjustable from 7 to 30 days, with running periods adjustable from 10 to 60 minutes.

7.2.1. The initial generator test interval shall be set to run for 60 minutes every two weeks.

7.3. The time delay for retransfer to normal power shall be adjustable from 0 to 30 minutes and factory set for 10 minutes. Provide automatic defeat of delay on loss of voltage or sustained undervoltage of emergency power, provided the normal power supply has been restored.

**11110-8. Remote Annunciator**

8.1. Provide a remote annunciator indicating generator status located in the administration area or other location requested by the BIA.

8.2. The annunciator shall be provided with an emergency generator shutdown button.

**11110-9. Fire Pump Generator Connection**

9.1. To avoid issues associated with overcurrent protection, it is recommended that the fire pump connection to the generator be made via a double lug at the generator.

**11110-10. Warranty**

10.1. The generator shall be provided with a 5-year warranty, minimum.

**11110-11. Uninterruptible Power Supply (UPS)**

11.1. Telecommunications room UPS requirements shall be per Chapter 13, "Information Technology."

11.2. A central UL 924 UPS system may be provided to support telecom, security, and computer equipment. Separate systems are also acceptable.

11.3. The UPS equipment shall be backed up by the generator standby power.

- 11.4.** Provide UPS power to computer receptacles as noted in Section 11040 via panelboards distribution.

**11120-1. General**

- 1.1. Perform an NFPA 780 risk assessment for the building site to evaluate the need for a lightning protection system.
  - 1.1.1. The risk assessment shall include the frequency of lightning in the area, the height of the building(s), surrounding buildings and terrain, the sensitivity of the equipment within the building, etc.
- 1.2. Provide a recommendation to the BIA as to whether or not a lightning protection system is required.
- 1.3. The BIA will review the analysis and recommendations and approve or disapprove the inclusion of a lightning protection system.
- 1.4. Refer to Section 11000 for additional information.

**11120-2. Installation**

- 2.1. The lightning protection system shall be installed in a manner as visually unobtrusive as possible.
- 2.2. Build in or hide conductors within the building structure wherever possible.
- 2.3. Provide proper flashing for a watertight seal for all roof penetrations.
- 2.4. Conceal the following conductors:
  - System conductors
  - Down-lead conductors
  - Interior conductors
  - Conductors within normal view from exterior locations at grade within 200 feet (60 meters) of the building
- 2.5. All down-lead conductors shall be fully concealed in plenum rated non-metallic raceway within the building walls. Down-lead conductors shall be protected from physical damage or displacement for a distance of not less than 8 feet above grade.

**11120-3. Components**

- 3.1. Provide a Franklin-rod type lightning protection system when required.
- 3.2. All materials and conductors shall be galvanically compatible.
- 3.3. Air terminal bases shall be cast bronze with bolted pressure cable connectors, suitable for fastening to the supporting structure.
- 3.4. Above-grade cable connections, bonding devices, cable splices, and miscellaneous connectors shall be cast bronze with bolted pressure connections to cable and shall be electrolytically compatible with the conductor type. Cast or stamped, crimp-style fittings are not acceptable for above-grade use.

- 3.5. Down-lead conductors shall be the same size and type as the main conductors if the structural steel of the building is not used.

**11120-4. UL Lightning Protection Inspection Certificate**

- 4.1. All lightning protection equipment shall be installed per master label requirements.
- 4.2. A LPI System Certification shall be obtained after construction is completed.

**11130-1. General**

- 1.1. The electrical system shall be commissioned to assure proper operation of the equipment and systems per the intent of the construction documents.
  - 1.1.1. Coordinate with the manufacturers' recommendations for means and methods of commissioning.
  - 1.1.2. Coordinate with the third-party Commissioning Agent as necessary to meet LEED requirements.
- 1.2. The commissioning requirements for systems noted below shall be included as a minimum.
- 1.3. Refer to the LEED guidelines for any additional requirements necessary to earn LEED credit.
- 1.4. Prior to commissioning, the contractor shall complete all phases of work, including normal contractor start-up, so that the systems can be started, tested, and otherwise commissioned.
- 1.5. Provide InterNational Electrical Testing Association (NETA) testing of electrical equipment where applicable.

**11130-2. Distribution System**

- 2.1. The overcurrent protection breaker settings shall be verified to meet the calculation requirements.
- 2.2. The UPS system shall be verified to be installed and operating correctly.

**11130-3. Renewable Energy Systems**

- 3.1. Any renewable energy systems installed shall be commissioned to ensure that the rated power of the system is achieved.

**11130-4. Cathodic Protection**

- 4.1. Commissioning of the cathodic protection system shall ensure that the expected results are obtained.
  - 4.1.1. Coordinate anticipated results with the type of system provided.
  - 4.1.2. Coordinate anticipated results with corrosion protection design.

**11130-5. Fire Alarm System**

- 5.1. Commissioning of the fire alarm system shall include the following:
  - 5.1.1. Verify the proper functioning of *every* device associated with the system.
  - 5.1.2. Verify that the device callouts within the programming of the fire alarm control panel match those of the shop drawings.
  - 5.1.3. Verify that the automatic notification system is connected to and received by the remote monitoring station.

- 5.1.4.** Perform all testing recommended and required by the NFPA and provide a completed Inspection and Testing form.

**11130-6. Meters****6.1. Commissioning of meters shall:**

- 6.1.1.** Verify that all metered information is accurate.
- 6.1.2.** Verify that all metered information is received and recorded by the direct digital control (DDC) system or other monitoring system designated by the BIA.

**11130-7. Lighting Controls****7.1. Commissioning of lighting controls shall:**

- 7.1.1.** Verify that the lighting control system(s) function as designed.
- 7.1.2.** Verify that automatic control set points are per design.

**11130-8. Generator****8.1. Commissioning of the generator shall:**

- 8.1.1.** Verify that the rated power of the generator system is achieved via the use of a portable load bank.
- 8.1.2.** Verify proper operation of the automatic transfer switch(es) (ATS(s)), including:
  - Load is properly transferred upon loss of normal power.
  - Load is properly transferred upon restoration of normal power.
  - Exercise clock properly exercises the generator.
  - Exercise clock is set for the correct interval for testing.
- 8.1.3.** Battery is charging correctly.
- 8.1.4.** Block heaters are functioning correctly.
- 8.1.5.** Remote annunciators are functioning correctly.
- 8.1.6.** The fuel system is full.



**11140-1. General**

- 1.1. Electrical systems training will be conducted in a classroom setting, with field demonstrations as appropriate, using system and component documentation and suitable classroom training aids.
- 1.2. The location of the training shall be determined by the Contracting Officer.
- 1.3. For all systems requiring training, a factory-authorized service representative shall be engaged to train the BIA's maintenance personnel as specified below:
  - 1.3.1. Provide training on starting up and shutting down, operating, troubleshooting, servicing, adjusting, and maintaining equipment and maintenance schedules. A minimum of three hours' training, or as noted below, shall be provided for *each* system.
  - 1.3.2. Use the approved final version of the operations and maintenance (O&M) manuals as training aids. Training shall not commence until approved O&M manuals are available.
  - 1.3.3. Training shall be scheduled with the owner with at least two weeks' advance notice.
- 1.4. All information provided in the training sessions shall be video taped and a minimum of two copies provided on DVD. Provide copies of written information and include the information in the O&M manuals. The training information shall be separated per subject for inclusion adjacent to the associated drawings, data sheets, etc., in the O&M manual.

**11140-2. Switchboards**

- 2.1. Provide a minimum of four hours' training.
- 2.2. The training session shall include instruction on the assembly, switches, changing fuses, checking torque on bus and cable connections, programming, viewing meter parameters, and other major components.

**11140-3. Surge Protection Device (SPD)**

- 3.1. The manufacturer's representative shall also provide training on the theory of the surge protection device (SPD) system.

**11140-4. Generator**

- 4.1. Provide a minimum of four hours' training on the generator, automatic transfer switch(es) (ATS(s)), fuel systems, cooling systems, battery charger, jacket heater, and normal maintenance such as oil changes, filter changes, air filters, etc.

**11140-5. Fire Alarm**

- 5.1. Provide a minimum of eight hours' training.

**11140-6. Other Systems to Be Included in the Training Sessions**

- 6.1.** Lighting controls.
- 6.2.** Uninterruptible power supply (UPS).
- 6.3.** Cathodic protection.
- 6.4.** Lightning protection.
- 6.5.** Renewable energy system.
- 6.6.** Other systems requiring maintenance or troubleshooting.

**11150-1. General**

- 1.1. Operating and maintenance (O&M) manuals shall include information on all equipment requiring support or maintenance for proper operation.
- 1.2. O&M manuals shall be provided prior to the training sessions called out in Section 11140, "Training."
- 1.3. The O&M manuals shall contain all shop drawings and data sheets; installation, testing, and operating instructions; and maintenance requirements and procedures.
- 1.4. The O&M manuals shall contain parts lists with ordering information.
- 1.5. A written copy and DVDs of the information provided at the training session(s) shall be included in the O&M manuals. The training information shall be separated by subject for inclusion adjacent to the associated drawings, data sheets, etc.

**11150-2. Minimum Requirements**

- 2.1. Provide O&M manuals on all equipment requiring submittal review and the following systems and equipment as a minimum:
  - Switchboards
  - Panelboards
  - Transformers
  - Generator
  - Light fixtures
  - Lighting control devices
  - Cathodic protection
  - Fire alarm
  - Lightning protection
  - UPS equipment
  - TVSS equipment
  - Metering equipment

11160-1. General

1.1. The following details represent the information that must be presented in the construction documents.

1.1.1. Variations in the format of the presented information will be acceptable, but will require approval by the BIA.

Figure 11160-1: Sample Panel Schedule

|   |  |                     |  |                                   |  |
|---|--|---------------------|--|-----------------------------------|--|
| PANEL: NAME                               |  | VOLTAGE: 277/480 V. |  | TYPE: LIGHTING & APPLIANCE        |  |
| FED FROM: xxxx                            |  | 3 PH                |  | MOUNTING: FLUSH                   |  |
| 100 AMP MAIN RATED @ 80%                  |  | 4 W.                |  | PANEL COVER: DOOR IN HINGED COVER |  |
| N/A AMP MAIN LUGS                         |  | 60 HZ               |  | NEUTRAL BUS: YES                  |  |
| 100 AMP BUS                               |  |                     |  | GROUND BUS: YES ISOLATED GND: NO  |  |
| COPPER BUSING                             |  |                     |  | NOTE: 1. [ ]                      |  |
| (SEE FAULT SCHEDULE) SYMMETRICAL RMS AMPS |  |                     |  | 2. [ ]                            |  |
| COMBINED PANEL SHORT CIRCUIT RATING       |  |                     |  | 3. [ ]                            |  |
|   |  |                     |  | 4. [ ]                            |  |

| NOTE | DESCRIPTION | CCT VA | BREAKER AMP / P | CCT PH CCT | BREAKER AMP / P | CCT VA | DESCRIPTION | NOTE |
|------|-------------|--------|-----------------|------------|-----------------|--------|-------------|------|
|      |             | 0      | 20 / 1          | 1 A 2      | 20 / 1          | 0      |             |      |
|      |             | 0      | 20 / 1          | 3 B 4      | 20 / 1          | 0      |             |      |
|      |             | 0      | 20 / 1          | 5 C 6      | 20 / 1          | 0      |             |      |
|      |             | 0      | 20 / 1          | 7 A 8      | 20 / 1          | 0      |             |      |
|      |             | 0      | 20 / 1          | 9 B 10     | 20 / 1          | 0      |             |      |
|      |             | 0      | 20 / 1          | 11 C 12    | 20 / 1          | 0      |             |      |
|      |             | 0      | 20 / 1          | 13 A 14    | 20 / 1          | 0      |             |      |
|      |             | 0      | 20 / 1          | 15 B 16    | 20 / 1          | 0      |             |      |
|      |             | 0      | 20 / 1          | 17 C 18    | 20 / 1          | 0      |             |      |
|      |             | 0      | 20 / 1          | 19 A 20    | 20 / 1          | 0      |             |      |
|      |             | 0      | 20 / 1          | 21 B 22    | 20 / 1          | 0      |             |      |
|      |             | 0      | 20 / 1          | 23 C 24    | 20 / 1          | 0      |             |      |
|      |             | 0      | 20 / 1          | 25 A 26    | 20 / 1          | 0      |             |      |
|      |             | 0      | 20 / 1          | 27 B 28    | 20 / 1          | 0      |             |      |
|      |             | 0      | 20 / 1          | 29 C 30    | 20 / 1          | 0      |             |      |
|      | SPARE       | 0      | 20 / 1          | 31 A 32    | 20 / 1          | 0      | SPARE       |      |
|      | SPARE       | 0      | 20 / 1          | 33 B 34    | 20 / 1          | 0      | SPARE       |      |
|      | SPARE       | 0      | 20 / 1          | 35 C 36    | 20 / 1          | 0      | SPARE       |      |
|      | SPARE       | 0      | 20 / 1          | 37 A 38    | 20 / 1          | 0      | SPARE       |      |
|      | SPARE       | 0      | 20 / 1          | 39 B 40    | 20 / 1          | 0      | SPARE       |      |
|      | SPARE       | 0      | 20 / 1          | 41 C 42    | 20 / 1          | 0      | SPARE       |      |
|      |             | 0      |                 | A          |                 | 0      |             |      |
|      |             | 0      |                 | B          |                 | 0      |             |      |
|      |             | 0      |                 | C          |                 | 0      |             |      |

| PANEL LOADING SUMMARY |          |          |          |              |
|-----------------------|----------|----------|----------|--------------|
| LOAD TYPE             | PH A     | PH B     | PH C     | TOTAL        |
| INCANDESCENT          | 0        | 0        | 0        | 0 kVA        |
| FLUORESCENT           | 0        | 0        | 0        | 0 kVA        |
| RECEPTACLES           | 0        | 0        | 0        | 0 kVA        |
| MOTORS                | 0        | 0        | 0        | 0 kVA        |
| APPLIANCE             | 0        | 0        | 0        | 0 kVA        |
| HEAT                  | 0        | 0        | 0        | 0 kVA        |
| COMPUTER              | 0        | 0        | 0        | 0 kVA        |
| MISC.                 | 0        | 0        | 0        | 0 kVA        |
| --                    | 0        | 0        | 0        | 0 kVA        |
| <b>TOTAL</b>          | <b>0</b> | <b>0</b> | <b>0</b> | <b>0 kVA</b> |

| NEC DEMAND LOAD SUMMARY |          |            |          |               |                 |            |
|-------------------------|----------|------------|----------|---------------|-----------------|------------|
| LOAD TYPE               | kW       | POWER FACT | kVA      | DEMAND FACTOR | CALCULATED LOAD |            |
| INCANDESCENT            | 0        | @ 100%     | = 0      | @ 125%        | = 0             | kVA        |
| FLUORESCENT             | 0        | @ 95%      | = 0      | @ 125%        | = 0             | kVA        |
| RECEPTACLES             |          |            |          |               |                 |            |
| FIRST 10 kVA            | 0        | @ 95%      | = 0      | @ 100%        | = 0             | kVA        |
| REMAINDER               | 0        | @ 95%      | = 0      | @ 50%         | = 0             | kVA        |
| MOTORS                  |          |            |          |               |                 |            |
| LARGEST                 | 0        | @ 80%      | = 0      | @ 125%        | = 0             | kVA        |
| REMAINDER               | 0        | @ 80%      | = 0      | @ 100%        | = 0             | kVA        |
| APPLIANCES              | 0        | @ 80%      | = 0      | @ 100%        | = 0             | kVA        |
| HEAT                    | 0        | @ 100%     | = 0      | @ 125%        | = 0             | kVA        |
| COMPUTER                | 0        | @ 75%      | = 0      | @ 100%        | = 0             | kVA        |
| MISC.                   | 0        | @ 85%      | = 0      | @ 100%        | = 0             | kVA        |
| --                      | 0        | @ 95%      | = 0      | @ 100%        | = 0             | kVA        |
| 25 % SPARE              | 0        | @ 90%      | = 0      | @ 100%        | = 0             | kVA        |
| <b>TOTAL</b>            | <b>0</b> | <b>kW</b>  | <b>0</b> | <b>kVA</b>    | <b>0</b>        | <b>kVA</b> |

|                   |     |     |     |    |
|-------------------|-----|-----|-----|----|
| PHASE BALANCE (%) | A-B | B-C | C-A | PF |
|                   | ##  | ##  | ##  | ## |

|                    |   |         |
|--------------------|---|---------|
| MIN PANEL AMPACITY | 0 | AMPERES |
|--------------------|---|---------|

Version 0106



Figure 11160-3: Sample Feeder Schedule

| <b>F E E D E R   S C H E D U L E</b> |  |                |
|--------------------------------------|--|----------------|
| <b>KEY</b>                           | <b>CONDUIT &amp; CONDUCTORS<br/>[SEE NOTE 1]</b> | <b>REMARKS</b> |
| 15A3GM                               | 1/2" C - 3#12, 1#12G                             | NOTE 5         |
| 20A2                                 | 3/4" C - 2#12                                    |                |
| 20A3                                 | 3/4" C - 3#12                                    |                |
| P20A2G                               | 3/4" C - 2#12, 1#12G                             | NOTE 4         |
| 125A3GM                              | 1-1/4" C - 3#3, 1#6G                             | NOTE 5         |
| 30A2GM                               | 1/2" C - 2#10, 1#10G                             | NOTE 5         |
| 30A5                                 | 3/4" C - 5#10                                    | NOTE 6         |
| 50A4BJN                              | 1-1/4" C - 3#6, 1#3N, 1#8G                       | NOTE 7         |
| 60A2GM                               | 3/4" C - 2#8, 1#10G                              | NOTE 5         |
| 70A3G                                | 1-1/4" C - 3#4, 1#8G                             |                |
| 80A4GN                               | 1-1/2" C - 3#3, 1#1/0N, 1#8G                     |                |
| 100A2                                | 1-1/4" C - 2#1                                   |                |
| 100A2G                               | 1-1/4" C - 2#1, 1#8G                             |                |
| 100A2GM                              | 1" C - 2#4, 1#8G                                 | NOTE 5         |
| P100A3GM                             | 1-1/4" C - 3#4, 1#8G                             | NOTES 4, 5     |
| 175A4BJN                             | 2-1/2" C - 5#4/0, 1#2G                           | NOTES 2, 7     |
| 400A4BJ                              | 2 [ 2-1/2" C - 4#250, 1#2G ]                     | NOTE 7         |
| 400A4GH                              | 2 [ 2-1/2" C - 4#250, 1#3G ]                     | NOTE 3         |
| P800A4GN                             | 3 [ 3-1/2" C - 5#400, 1#1/0G ]                   | NOTES 2, 4     |
|                                      |  |                |
|                                      |  |                |
|                                      |  |                |
|                                      |  |                |
|                                      |  |                |
|                                      |  |                |

Figure 11160-4: Sample Kitchen Equipment Schedule

| KITCHEN EQUIPMENT SCHEDULE |                               |           |    |           |         |          |                    |        |                 |                       |                 |         |   |   |   |     |     |
|----------------------------|-------------------------------|-----------|----|-----------|---------|----------|--------------------|--------|-----------------|-----------------------|-----------------|---------|---|---|---|-----|-----|
| KEY                        | ITEM DESCRIPTION (SEE NOTE 1) | A/C VOLTS | PH | UNIT AMPS | UNIT KW | UNIT KVA | PANEL (SEE NOTE 2) | FEEDER | LOCAL DISC. SW. | ELECTRICAL CONNECTION | MOUNTING HEIGHT | REMARKS |   |   |   |     |     |
| K-0                        |                               | 0         | 0  | 0.0       | 0.0     | 0.0      | 0                  | #N/A   | 0.0             | 0.0                   | 0.0             | 0       |   |   |   |     |     |
| K-0                        |                               | 0         | 0  | 0.0       | 0.0     | 0.0      | 0                  | #N/A   | 0.0             | 0.0                   | 0.0             | 0       |   |   |   |     |     |
| K-0                        |                               | 0         | 0  | 0.0       | 0.0     | 0.0      | 0                  | #N/A   | 0.0             | 0.0                   | 0.0             | 0       |   |   |   |     |     |
| K-0                        |                               | 0         | 0  | 0.0       | 0.0     | 0.0      | 0                  | #N/A   | 0.0             | 0.0                   | 0.0             | 0       |   |   |   |     |     |
| TOTALS                     |                               |           |    |           |         |          |                    |        |                 |                       |                 | 0       | 0 | 0 | 0 | 0.0 | KVA |

Version 0106

NOTES:  
 1. COORDINATE ELECTRICAL EQUIPMENT REQUIREMENTS WITH THE ACTUAL EQUIPMENT SUPPLIED.  
 2. REFER TO PANEL SCHEDULES FOR EXACT CIRCUIT NUMBER.



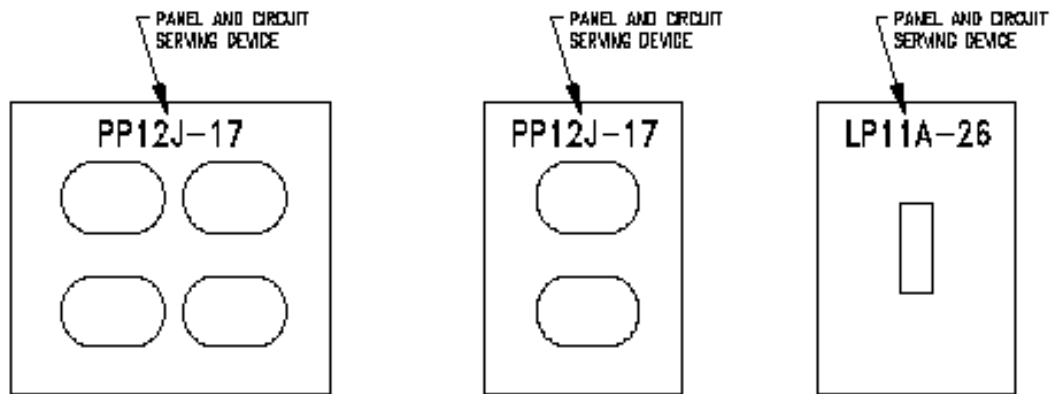

Figure 11160-6: Sample Motor Control Center Schedule

| MOTOR CONTROL CENTER SCHEDULE |                  |                  |          |          |        |             |                        |            |     |              |                  |         |
|-------------------------------|------------------|------------------|----------|----------|--------|-------------|------------------------|------------|-----|--------------|------------------|---------|
| NOG No.                       |                  | GP-MGD2          | VOLTAGE  | 480V-3PH | NEMA 1 | ENCLOSURE   | LOCATION CENTRAL PLANT |            |     |              | 800 AMP MAIN BUS |         |
| NO.                           | MECH. EQUIP. NO. | LOAD DESCRIPTION | LOAD HP. | STARTER  |        | SWITCH SIZE | FUSE SIZE              | CONDUCTORS |     | CONDUIT SIZE | FLA              | REMARKS |
|                               |                  |                  |          | SIZE     | TYPE   |             |                        | PHASE      | EGC |              |                  |         |
| 1                             |                  |                  |          |          |        |             |                        |            |     |              |                  |         |
| 2                             |                  |                  |          |          |        |             |                        |            |     |              |                  |         |
| 3                             |                  |                  |          |          |        |             |                        |            |     |              |                  |         |
| 4                             |                  |                  |          |          |        |             |                        |            |     |              |                  |         |
| 5                             |                  |                  |          |          |        |             |                        |            |     |              |                  |         |
| 6                             |                  |                  |          |          |        |             |                        |            |     |              |                  |         |
| 7                             |                  |                  |          |          |        |             |                        |            |     |              |                  |         |
| 8                             |                  |                  |          |          |        |             |                        |            |     |              |                  |         |
| 9                             |                  |                  |          |          |        |             |                        |            |     |              |                  |         |
| 10                            |                  |                  |          |          |        |             |                        |            |     |              |                  |         |
| 11                            |                  |                  |          |          |        |             |                        |            |     |              |                  |         |
| 12                            |                  |                  |          |          |        |             |                        |            |     |              |                  |         |
| 13                            |                  |                  |          |          |        |             |                        |            |     |              |                  |         |

TOTAL: 132A

Figure 11160-7: Sample Device Labeling Detail



**DEVICE LABELING DETAIL**

SCALE: NONE

NOTE: LABEL WITH BROTHER "P-TOUCH" SYSTEM. PROVIDE CLEAR OR WHITE TAPE WITH BLACK LETTERING.

Figure 11160-8: Sample Mounting Height Detail

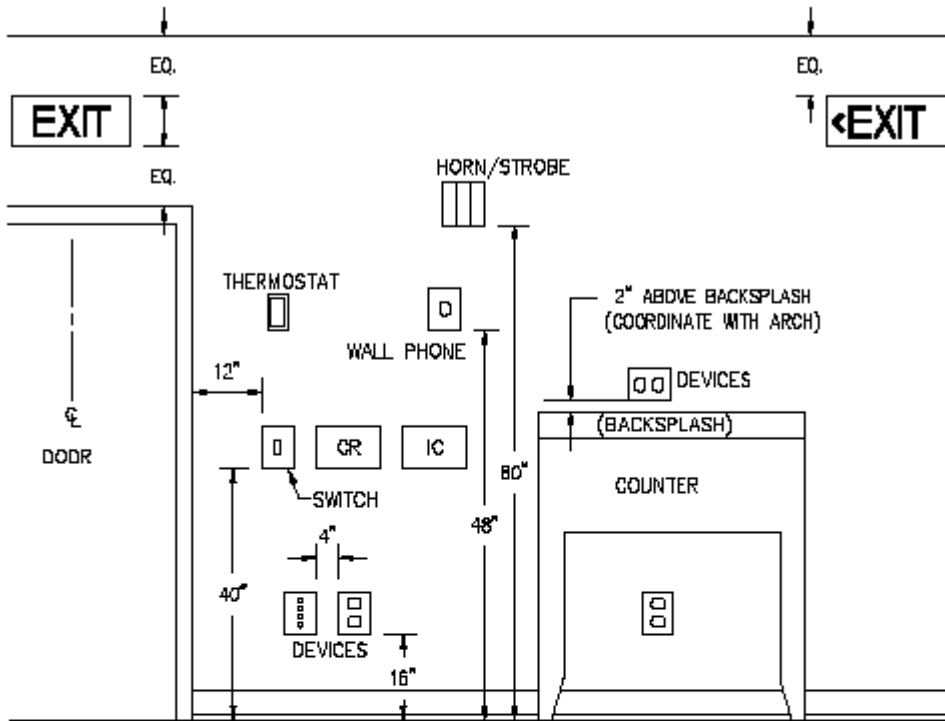

OFFICES

**ELECTRICAL COMPONENT MOUNTING HEIGHTS**

SCALE: NONE

NOTES:

1. HEIGHTS SHOWN ARE TYPICAL TO BOTTOM OF DEVICE UNLESS NOTED OTHERWISE.
2. DEVICES ABOVE DOORS SHALL BE CENTERED BETWEEN TOP OF DOOR TRIM AND CEILING LINE.
3. MOUNTING HEIGHTS SHOWN ON ARCHITECTURAL ELEVATIONS SHALL GOVERN OVER THOSE SHOWN ABOVE.
4. INSTALL FIRE ALARM NOTIFICATION APPLIANCES AT 80" A.F.F., OTHERWISE INSTALL AT 6" BELOW CEILING.

Figure 11160-9: Sample Transformer Schedule

| 480 Volt - 120/208 Volt Transformer Sizes and Feeders |                       |     |         |        |           |        |                        |         |
|---|-----------------------|-----|---------|--------|-----------|--------|------------------------|---------|
| Load Type (Name)                                      | NEC DMND.<br>LOAD KVA | kVA | Primary |        | Secondary |        | Grounding<br>Electrode | Remarks |
|   |                       |     | OCP     | Feeder | OCP       | Feeder |                        |         |
| Basement  |                       |     |         |        |           |        |                        |         |
| First   |                       |     |         |        |           |        |                        |         |
| Second  |                       |     |         |        |           |        |                        |         |
| Third   |                       |     |         |        |           |        |                        |         |
| Fourth  |                       |     |         |        |           |        |                        |         |
| Fifth   |                       |     |         |        |           |        |                        |         |
| Penthouse   |                       |     |         |        |           |        |                        |         |

**12000-1. Introduction**

- 1.1. This chapter shall be used as a guideline in the development of a fire protection systems performance specification for all new BIA justice/detention facilities. A qualified fire protection engineer shall work in conjunction with the architectural Designer of Record to develop the specification, which will be used by the fire protection contractor. The design shall be in conformance with these guidelines unless exceptions to them are granted by the BIA.
- 1.2. Refer to Chapter 1, “General Information,” and Chapter 2, “Presentation of Data,” for required documents, drawing and specifications formats, and other design and submittal requirements not discussed in this chapter.
- 1.3. Additional design and submittal requirements may apply for projects with unusual or highly technical criteria.
- 1.4. As applicable, the Designer of Record shall incorporate the sustainability strategies identified in Chapter 3, “LEED Goals and Guidelines.”
- 1.5. The guidelines in this chapter should be used in conjunction with those in the other chapters in this handbook, and the Designer of Record should coordinate with the other project consultants to be sure all aspects of the justice/detention facility are effective and compatible.
- 1.6. All design features must be weighed carefully for their initial cost, long-term maintenance cost and needs, durability, and their impact on the environment.
- 1.7. Fire sprinkler systems and fire suppression systems shall be provided for all new BIA justice/detention facility buildings and associated facilities, including maintenance facilities and kitchens in accordance with NFPA 5000 Building Construction and Safety Code, other applicable NFPA standards, and the requirements listed herein.
- 1.8. Refer to Section 11100, “Fire Alarm System,” for fire alarm system requirements.

**12000-2. Fire Protection Engineer**

- 2.1. The design of the fire protection systems shall be under the responsible charge of a qualified fire protection engineer (FPE), an individual meeting one of the following requirements:
  - 2.1.1. An engineer having a bachelor of science or master of science degree in fire protection engineering from an accredited university engineering program, plus a minimum of two years’ work experience in fire protection engineering.
  - 2.1.2. A registered professional engineer (PE) in fire protection engineering.
  - 2.1.3. A registered architect (RA) with member grade status in the National Society of Fire Protection Engineers (NSFPE). Services of the RA shall be limited to building code applications and life safety code analysis.

**12000-3. Fire Protection Design Analysis**

3.1. A fire protection design analysis is required for all designs and must address the fire protection requirements of the project. The FPE, in conjunction with the architectural Designer of Record, shall be responsible for the fire protection design analysis. Where applicable, the design analysis, as a minimum, shall discuss the following:

- Building construction type, height and area limitations, and building separation and exposure protection
- Classification of occupancy
- Specific compliance with applicable section(s) of the NFPA's National Fire Code
- Requirements for fire-rated walls, fire-rated doors, fire dampers with their fire-resistive ratings, smoke compartmentalization, smoke barriers, and smoke dampers
- NFPA 5000 Building Construction and Safety Code
- Analysis of automatic suppression systems and protected areas
- Water supplies, including location and connection compatibility with the local fire department
- Smoke control systems
- Fire alarm system (the type of alarm system and location of the fire alarm equipment and fire zones)
- Standpipe systems and fire extinguishers
- Interior finish ratings
- Connection to and description of the fire alarm reporting system
- The various occupancies and hazardous areas associated with the facility
- Coordination with security and fire protection requirements
- Fire department access

**12000-4. Design Submission**

4.1. At the 100 percent design submission of plans and specifications, the FPE shall certify in writing that the design is in compliance with the requirements and all applicable criteria.

**12000-5. Design**

5.1. The fire protection performance specifications shall require the fire protection contractor, in conjunction with a qualified FPE, to provide detailed design (calculations and drawings) of the fire protection systems in accordance with items listed below.

- 5.1.1. Prepare drawings and calculations showing the layout and design of the fire protection system. Coordination drawings, including all building components, shall show routing of piping, sprinkler head locations, etc. Drawings shall conform to the requirements of NFPA 13 and shall be accurately dimensioned to show the proposed location of all fire protection system components. Drawings shall be prepared on AutoCAD, and the drawing sizes shall be the same as those of the architectural drawings.
- 5.1.2. All materials and equipment used in the installation of the fire protection system shall be as approved in the Underwriters Laboratories (UL) list of inspected fire protection equipment and materials, or the Factory Mutual (FM) list of approved equipment and fire protection devices, and shall be the latest product of the manufacturer. Fire sprinkler shop drawings and calculations shall be sealed and signed by a registered fire professional engineer, who shall certify that the sprinkler installation meets both the requirements herein and applicable sections of NFPA standards.

#### **12000-6. Coordination**

- 6.1. Coordinating with other disciplines, the architectural Designer of Record and the FPE shall ensure the design includes the following:
  - 6.1.1. Flow and tamper switches are provided at all floor control valves and monitored valves.
  - 6.1.2. Smoke detectors are provided at fire/smoke dampers.
  - 6.1.3. The main test drain location is suitable for the volume of flow anticipated.
  - 6.1.4. Duct-mounted smoke detectors close the associated smoke dampers when the associated air distribution system is shut down.
  - 6.1.5. System zoning and subzoning is identified and indicated in the contract documents.
  - 6.1.6. Fire protection equipment is located to facilitate maintenance and repair or replacement of equipment components. Equipment connections are provided for ease of disconnecting and to allow minimum interference with other installations.

**12010-1. Systems Evaluation**

- 1.1. Fire protection systems for BIA justice/detention facilities shall be evaluated based on the following criteria. The criteria are listed in order of priority and are followed by additional information applicable to them.

**1.1.1. Critical Building Systems**

- The more critical the system, the more reliable it shall be.
- If a system is determined to be essential to the operation of the building, consideration shall be given to providing system redundancy.

**1.1.2. Standardization**

- The design shall follow BIA standards and local fire department requirements (if any).
- The design shall follow industry standards. Should conflicts occur between BIA and industry standards, BIA standards shall be used.

**1.1.3. Training Standardization**

- Systems requiring less training are preferred.

**1.1.4. Operations and Maintenance Concerns**

- Systems requiring less maintenance are preferred.

**1.1.5. Limitation of Flexibility/Creativity**

- System designs shall be well established within the industry.
- BIA facilities designed per this handbook shall have fire protection systems similar to comparable buildings at other BIA facilities that were also designed according to the guidelines in this handbook.

**1.1.6. Available Infrastructure**

- The available utilities shall be coordinated with the specific project site at the beginning of the project to ensure that the systems specified can be supported by the local utilities.

**1.1.7. Constructability**

- The ease of construction of the proposed system shall be considered.
- The availability of workers skilled in the installation of a proposed system shall also be considered.

**1.1.8. Commissioning**

- Systems requiring less commissioning are preferred.

**1.1.9. Site Constraints and Criteria**



- The system proposed shall be compatible with site constraints and requirements.

#### **1.1.10. *Climate Influences***

- The system proposed shall be compatible with the climate of the project site.

#### **1.1.11. *Infrastructure Flexibility/Expandability***

- The system design shall be able to accommodate future expansion as required by the BIA.

- 1.2.** Where a clear system selection is *not* readily determined by examining the above criteria, present the information available, relative to those criteria, to the BIA for review and selection.

**12020-1. General**

- 1.1. For the design of fire protection systems for BIA justice/detention facilities, follow all applicable current codes, standards, and laws. For general list of codes and standards that apply to BIA justice/detention facilities, refer to Chapter 1, “General Information.” During design, report any required deviations from codes and standards to the Contracting Officer.
- 1.2. Where two codes, standards, or laws are applicable to the topic under review, use the more conservative or more stringent. In the case of conflict, follow the requirement that provides the highest level of safety (as determined by the fire protection engineer) unless contrary instruction is given in writing by the BIA. Consult with the BIA Office of Facilities Management and Construction (OFMC) to resolve any questions or conflicts regarding application of codes and standards.
- 1.3. The ARCOM MASTERSPEC, Division 21, along with the standards and guidelines in the publications listed below, shall be used as references for specification development.
- 1.4. All appendices of referenced NFPA standards shall be considered part of the applicable standards for design and interpretation purposes.
- 1.5. Nothing in this handbook shall be construed to relieve the fire protection engineer (FPE) or the contractor of their responsibility with respect to applicable codes, laws, or ordinances.

**12020-2. Applicable Codes and Standards**

- 2.1. The design criteria shall comply with the guidelines contained in the following unless noted otherwise:

**2.1.1. *American National Standards Institute (ANSI)***

|            |  |
|------------|--|
| ANSI/      | Safety Code for Elevators and Escalators |
| ASME A17.1 |  |

**2.1.2. *American Society of Mechanical Engineers (ASME)***

|              |  |
|--------------|--|
| ASME B16.1   | Cast Iron Pipe Flanges and Flanged Fittings                    |
| ASME B16.3   | Malleable Iron Threaded Fittings                               |
| ASME B16.4   | Gray Iron Threaded Fittings                                    |
| ASME B16.9   | Factory-Made Wrought Butt welding Fittings                     |
| ASME B16.11  | Forged Fittings, Socket-Welding and Threaded                   |
| ASME B16.18  | Cast Copper Alloy Solder Joint Pressure Fittings               |
| ASME B16.21  | Nonmetallic Flat Gaskets for Pipe Flanges                      |
| ASME B16.22  | Wrought Copper and Copper Alloy Solder Joint Pressure Fittings |
| ASME B18.2.1 | Square and Hex Bolts and Screws, Inch Series                   |

ASME B18.2.2 Square and Hex Nuts

**2.1.3. *American Society of Sanitary Engineering (ASSE)***

ASSE 1015 Performance Requirements for Double Check Backflow Prevention Assemblies and Double Check Fire Protection Backflow Prevention Assemblies

**2.1.4. *American Society for Testing and Materials (ASTM)***

ASTM A47 Standard Specification for Ferritic Malleable Iron Castings

ASTM A53 Standard Specification for Pipe, Steel, Black and Hot-Dipped, Zinc-Coated, Welded and Seamless

ASTM A135 Standard Specification for Electric-Resistance-Welded Steel Pipe

ASTM A183 Standard Specification for Carbon Steel Track Bolts and Nuts

ASTM A536 Standard Specification for Ductile Iron Castings

ASTM A795 Standard Specification for Black and Hot-Dipped Zinc-Coated (Galvanized) Welded and Seamless Steel Pipe for Fire Protection Use

ASTM B88 Standard Specification for Seamless Copper Water Tube

**2.1.5. *Factory Mutual Engineering and Research (FM)***

FM P7825a Approval Guide Fire Protection

FM P7825b Approval Guide Electrical Equipment

**2.1.6. *Manufacturers Standardization Society of the Valve and Fittings Industry (MSS)***

MSS SP-71 Gray Iron Swing Check Valves, Flanges and Threaded Ends

**2.1.7. *National Fire Protection Association (NFPA)***

NFPA 13 Standard for the Installation of Sprinkler Systems

NFPA 14 Standard for the Installation of Standpipes and Hose Systems

NFPA 20 Standard for the Installation of Stationary Pumps for Fire Protection

NFPA 24 Standard for the Installation of Private Fire Service Mains and Their Appurtenances

NFPA 25 Standard for the Inspection, Testing, and Maintenance of Water-Based Fire Protection Systems

NFPA 1963 Standard for Fire Hose Connections

NFPA 5000 Building Construction and Safety Code

**2.1.8. *National Institute for Certification in Engineering Technologies (NICET)***

NICET 1014 Automatic Sprinkler System Layout [Program Detail Manual for Certification in the Field of Fire Protection Engineering Technology]

**2.1.9. *Underwriters Laboratories (UL)***

UL Building Materials

UL Fire Protection Equipment

**12030-1. General**

- 1.1. **Automatic Fire Suppression Systems.** The engineered and installed automatic fire suppression systems in BIA justice/detention facilities shall be designed to distribute water or a suppression agent in sufficient quantity to either control or extinguish the fire.
- 1.2. **Connections to Fire Reporting Systems.** Fire suppression systems must be connected to the fire reporting system for transmission of fire alarms, trouble signals, and supervisory signals.
- 1.3. **Plans and Calculations.** Fire suppression specifications must include provisions regarding fire suppression contractor qualifications. Sprinkler shop drawings shall be sealed and signed by a registered fire professional engineer (PE), who shall certify that the sprinkler installation meets the requirements herein and applicable sections of NFPA codes and standards. Submit the fire suppression system calculations and construction (shop) drawings to the designated fire protection engineer (FPE) for approval.
- 1.4. **Water Flow Testing.** Water flow tests shall be conducted to determine available water quantities and pressures for the fire protection systems. The FPE shall witness the required flow testing and verify that the test results are accurate. Accepting historical water supply information or similar data without verification is *not* permitted. Conduct water flow tests prior to the concept design submission.

**12030-2. Automatic Suppression Systems**

- 2.1. Automatic sprinkler systems shall be designed in accordance with NFPA 5000, NFPA 13, and the requirements herein.
- 2.2. **Application Requirements.** Complete automatic sprinkler protection must be provided in all new BIA justice/detention and associated buildings. Kitchen hoods shall be protected utilizing wet chemical, dry chemical, or wet sprinkler systems. A clean agent (FM-200) system may be used for computer/server rooms. Carbon dioxide systems shall *not* be used for BIA justice/detention and associated buildings.
  - 2.2.1. Coverage shall include 100 percent of the building, including electrical rooms, boiler rooms, telephone rooms, and mechanical rooms.
  - 2.2.2. The BIA requires that all Bureau-owned buildings exceeding 2,000 square feet in gross floor area, regardless of occupancy, be fully sprinkled with automatic sprinkler protection in accordance with NFPA 13, using Ordinary Hazard occupancy classification as the minimum design risk factor.
  - 2.2.3. Sprinkler systems shall be designed using hydraulic calculations. A pipe schedule design is not allowed.

- 2.2.4.** For dry pipe systems, the design area of the sprinkler operation must be increased by 30 percent per NFPA 13.
- 2.2.5.** The design areas must be increased by 30 percent for sloped ceilings that exceed a pitch of 1 in 6.
- 2.2.6.** The use of quick-response automatic sprinklers (QRASs) is limited to wet systems.
- 2.2.7.** Provide a separate, independent branch line system with a shutoff valve for the elevator equipment room and hoistway to meet the requirements of ANSI/ASME A17.1 and local codes. The hoistway and machine room shall be classified Ordinary Hazard. Install a shutoff valve outside of the shaft and equipment room.
- 2.2.8.** Standpipe systems shall have a 2½-inch outlet with a valve connection. Coordinate the location of the fire department's connection and standpipe connection with the fire department.
- 2.2.9.** Fire pumps are not to be used without prior approval. Calculations shall be submitted to show that a pump is necessary to meet the sprinkler and standpipe requirements.
- 2.2.10.** The inspector's test valve locations are to be located at the highest and most remote location on the piping system (not on the riser near the drain).
- 2.2.11.** When outside post indicating valves are required, they must be supervised.
- 2.2.12.** Double-check backflow preventers are required on all fire sprinkler systems.
- 2.2.13.** Sprinkler systems shall be zoned with floor/area control valves.
- 2.2.13.1.** System Zoning: Zoning and subzoning shall be identified and indicated in the contract documents.
- 2.2.14.** Install supervisory/tamper switches on all control valves.
- 2.2.15.** Sprinklers subject to damage and/or located within 7 feet 0 inches of the floor and sprinklers protecting electrical or mechanical rooms shall be provided with approved guards.
- 2.2.16.** Tamper/supervisory switch signals shall initiate a unique supervisory alarm signal at the building fire alarm control panel (FACP).
- 2.2.17.** Other system supervisory signals shall provide unique indications of system supervisory status.
- 2.2.18.** Dry pendant heads may be used in areas that are subject to freezing if adequate coverage can be achieved; otherwise, dry pipe sprinkler systems or antifreeze additive to wet systems shall be used.
- 2.2.19.** Required pressure gauges shall be equipped with a shutoff valve and with provision for draining.

- 2.2.20.** In areas within reach of unsupervised detainee's, institution type tamper resistant pendant and sidewall sprinkler heads shall be utilized. Concealed type pendant heads shall be utilized in all other areas of supervised detainee access or unsupervised areas where the ceiling mounted heads are not readily accessible.
- 2.2.21.** Window sprinklers may be used where required to protect rated assemblies.
- 2.2.22.** Unless directed otherwise by the BIA, provide a double-interlock preaction fire suppression system to service all detention areas. Where smoke control is provided each preaction system shall be interlocked with each smoke zone so that the initiation of the preaction system shall activate the smoke control system for that zone.

### 12030-3. Water Supply

- 3.1. Civil.** Refer to Chapter 5, "Civil," for information on hydrant requirements, storage tanks, and other fire-related equipment located outside the building.
- 3.2.** Flow velocity in underground water mains shall not exceed 16 feet per second. Velocity in above-ground sprinkler system piping shall not exceed 20 feet per second.
- 3.3. Distribution Mains.** The distribution system must be sized to accommodate fire flows (sprinkler plus hose stream) plus domestic or industrial demands that cannot be restricted during fires. Distribution must be looped to provide at least 50 percent of the required fire flow in case of a single break. Dead-end mains must be avoided. Distribution systems must be designed in accordance with NFPA 24 and the American Water Works Association Manual M31 Distribution System Requirements for Fire Protection. Coordinate with the civil engineer.
- 3.4.** Provide a pressure gauge on the street side of the check valves.
- 3.5. Flow Test Pressure Data.** Hydraulic calculations shall be based on 90 percent of the flow test pressure data to accommodate for seasonal and future reductions in available flow/pressure.
- 3.6.** The possibility of microbiologically influenced corrosion (MIC) shall be considered by the FPE. If MIC is determined to be a potential problem, action such as testing and evaluation of the sprinkler water shall be taken to prevent/minimize the risk. Refer to the NFPA for additional information regarding evaluation and test methods for MIC.

### 12030-4. Fire Pumps

- 4.1. Requirements.** Pumps for fire protection must have adequate capacity with reliable power and water supply. This equipment must conform to the requirements of NFPA 20. Fire pumps, drivers, and other equipment, including automatic accessories, must be UL listed, Factory Mutual (FM) approved, or listed or classified by a nationally recognized testing laboratory.

- 4.2. Fire pumps must be located in a detached, noncombustible pump house, or located in a two-hour fire-rated room (a one-hour rated room where the pump room is sprinkled) with direct access from the exterior.
- 4.3. A secondary fire pump must be provided when the water supply cannot support 25 percent of the sprinklers in the hydraulically most remote design area with the primary fire pump out of service.
- 4.4. **Pump Type.** A fire pump may be either a horizontal or vertical shaft centrifugal pump or a vertical shaft turbine pump, whichever is most economical and appropriate for the intended use.
- 4.5. **Pump Starting Arrangement.** Fire pumps must be arranged to start automatically.
- 4.6. **Pump Shutdown.** Once started, fire pumps must be arranged to run until they are shut down manually.

*Exception 1: Operation by automatic periodic exercise timers used for the required preventive maintenance run times.*

*Exception 2: Automatic shutdown upon total exhaustion of suction reservoir water may be permitted.*

- 4.7. **Jockey Pump.** Provide a pressure maintenance pump to make up the allowable leakage rate in the system. The pump shall be of the size and capacity required by the system and the NFPA. The jockey pump shall be controlled by a combination magnetic starter operating in conjunction with a pressure switch. The combination starter shall be equipped with three coil overloads and shall have a hand-off-auto (H-O-A) switch in the cover.
- 4.8. **Pump Drive.** When electric power is economically available, from a reliable single power source or from two independent sources in accordance with NFPA 20, pumps must be electrically driven only. A reliable single power source is defined as a power source having an average forced downtime, excluding scheduled repairs, that does not exceed 8 consecutive hours for any one incident or more than 24 hours cumulatively over the last three years. When such electrical power supplies are not available, fire pumps must be diesel driven. Spark-ignited internal combustion engines must not be used to drive fire pumps.

*Exception: A diesel-driven fire pump does not have to be provided when the fire pump is equipped with an automatic transfer switch and connected to an emergency generator.*

#### **12030-5. Fire Pump Controller**

- 5.1. The fire pump controller shall be UL listed and FM approved for fire pump service. The controller shall meet the requirements of NFPA 20. It shall be completely factory wired, assembled, and tested prior to shipment. The controller shall be of the combined manual/automatic type sized to operate the fire pump motor and designed for reduced-voltage, auto-transformer type



starting. All controller components shall be UL listed or UL recognized and shall be front mounted and wired, allowing the controller to mount flush against a wall.

- 5.2. The circuit breaker shall have an integral, nonadjustable instantaneous trip mechanism. The controller shall include a full National Electrical Manufacturers Association (NEMA)–rated contactor capable of operation by an external emergency operating handle. (An International Engineering Consortium (IEC)–only rated contactor will not be acceptable.)
- 5.3. A bourdon tube–type pressure switch with adjustable independent high and low set points and an appropriate range shall also be furnished. The pressure switch shall be sealable to prevent unauthorized adjustment. The pressure switch shall be mounted inside the controller cabinet.
- 5.4. An externally mounted pilot light shall be furnished to indicate that controller primary power is available.
- 5.5. Dry alarm contacts for remote alarm of "Pump Running," "Controller Power Available," and "Phase Reversal" shall be supplied. One normally open and one normally closed contact for each alarm shall be supplied. Controller power shall be monitored by the associated automatic transfer switch.

#### 12030-6. Automatic Transfer Switch

- 6.1. **General.** The automatic transfer switches shall provide manual or automatic operation of electric fire pump controllers from an alternate source of power when the normal source fails. The transfer switch is a part of the fire pump controller, and although mounted in a separate compartment, shall be factory assembled, shipped, and installed as a part of the controller. The transfer switch shall be rated for the intended duty and coordinated with the electrical contractor.
- 6.2. **Alarm Contacts.** An auxiliary, normally open contact shall be provided for the remote annunciation of the transfer switch position.
- 6.3. **Additional Features.** Supply a test switch that simulates the loss of normal power in order to test the operation of the transfer switch without interrupting normal service to the fire pump controller. Two pilot lights shall be provided on the outside of the transfer switch enclosure: one for normal position and one for emergency position, to give visual indication of the switch position. The pilot lights shall be controlled by auxiliary contacts off the transfer mechanism to ensure positive indication of switch position.

#### 12030-7. Standpipes

- 7.1. When required, standpipe systems must be installed in accordance with NFPA 5000, NFPA 14, and the requirements herein.

*Exception: Residual pressure requirements specified in NFPA 14 may be omitted for buildings less than 150 feet in height where fire department apparatus are expected to boost pressure in standpipe systems.*

**12030-8. Elevator Machine Rooms and Hoistways**

- 8.1. Provide 286°F sprinklers, with head guards, in elevator machine rooms and hoistways (where required). Sprinklers are required at the top of hoistways per NFPA 13 (except where the hoistway for a passenger elevator is noncombustible and the car enclosure materials meet the requirements of ANSI/ASME A17.1). Sprinklers are not required at the bottom of noncombustible hoistways for elevators that do not use hydraulic fluid.
- 8.2. Provide a control valve with a tamper/supervisory switch outside elevator machine rooms and shafts.
- 8.3. Provide smoke detectors for elevator recall.
- 8.4. Provide one 190°F fixed-temperature non-resetting heat detector adjacent to each sprinkler. After the elevator is recalled and prior to the application of water, heat detectors shall automatically disconnect power to the elevator machinery and the elevator controller. Provision of detectors and power disconnects is normally under the Electrical division of the project specifications. Coordinate between mechanical and electrical disciplines for proper detector and sprinkler locations.
- 8.5. Supervision of detectors shall be included under the Electrical division of the project specifications.
- 8.6. Each bank of elevators and associated equipment rooms shall be protected by an independent system unless determined otherwise by the FPE and approved by the BIA.

**12030-9. Dry Pipe Systems**

- 9.1. The system shall be monitored for low gas pressure.
- 9.2. A slope shall be provided as required for dry systems per NFPA 13. All trapped sections of piping shall be provided with auxiliary drains as required by NFPA 13. All drains shall have minimum 1-inch valves with a plug at all low points.

*Note: This requirement exceeds the provisions of NFPA 13.*

- 9.3. A valve shall be located within an artificially lighted and heated enclosure.
- 9.4. A valve shall be installed in the vertical position at 24 inches to 48 inches above the finished floor (AFF).

**12030-10. Piping**

- 10.1. All piping shall be USA-manufactured Schedule 10 or 40 piping for 2½-inch and larger, and Schedule 40 steel for all piping 2-inch and smaller as required by NFPA 13. Threaded thin-wall piping less than schedule 10 may not be used.
- 10.2. Copper tubing may be used if identified as desirable by the FPE. Full compliance with NFPA 13 requirements and recommendations is required.

- 10.3. Pipe joining: Fittings shall comply with NFPA 13 requirements. Grooved couplings, fittings, and gaskets used throughout a system shall be supplied from the same manufacturer and designed for the specific installation.
- 10.4. Threaded fittings are preferred in architecturally exposed or sensitive areas.
- 10.5. Design, hydraulic data, and fabrication documentation shall be submitted on the use of segmentally welded fittings.
- 10.6. Threaded and cut-grooved pipes are subject to the limitations of NFPA 13.
- 10.7. Face bushings and hexagonal bushings shall not be permitted.
- 10.8. Roll groove joints are not allowed on dry pipe or preaction systems.
- 10.9. Galvanized pipe may be necessary for drain lines as determined by the FPE. Dry pipe and preaction systems may use galvanized pipe as deemed necessary by the FPE.

#### **12030-11. Drain and Test Valves**

- 11.1. All main drains shall discharge to the building exterior through a properly sized drain riser. The FPE shall determine the routing of the drain and discharge locations and shall indicate these on the drawings.
  - 11.1.1. Sight glasses shall be provided on all inspectors' test connections where discharge cannot be seen while valves are operated.
  - 11.1.2. All drains shall be piped to the outside of the building at a point that won't cause water damage, and shall terminate with a 45-degree elbow. This includes the drain for the fire department connection piping (exception: auxiliary drains). The contractor shall supply and install a concrete splash block with a minimum length of 4 feet to direct the drain or test discharge water so as not to disturb adjacent landscape.
  - 11.1.3. Drain valves shall be made accessible and operable from the floor unless otherwise proposed by the FPE and accepted in writing by the BIA.
  - 11.1.4. Galvanized pipe may be necessary for drain lines as determined by the FPE.

#### **12030-12. System Zoning**

- 12.1. Zoning and subzoning shall be identified and indicated in the contract documents.

#### **12030-13. Identification Signs**

- 13.1. Provide identification signs at all control, drain, test, and alarm valves. Signs shall be of the type and size and at the location required by the NFPA.

#### **12030-14. Seismic Considerations**

- 14.1. In areas where seismic site classification warrants the design of seismic restraints for fire suppression systems, a seismic design shall be provided to comply with performance requirements and design criteria, including analysis

data signed and sealed by the qualified licensed professional engineer responsible for their preparation in accordance with NFPA requirements.

**13000-1. Introduction**

- 1.1. This chapter shall be used as a guideline for the design of technology systems for all new BIA Justice and Detention facilities. The design shall be in conformance with these guidelines unless exceptions to them are granted by the BIA.
- 1.2. Refer to Chapter 1, “General Information,” and Chapter 2, “Presentation of Data,” for required documents, drawing and specifications formats, and other design and submittal requirements not discussed in this chapter.
- 1.3. Additional design and submittal requirements may apply for projects with unusual or highly technical criteria.
- 1.4. As applicable, the designer of record shall incorporate the sustainability strategies identified in Chapter 3, “LEED Goals and Guidelines.”
- 1.5. The guidelines in this chapter shall be used in conjunction with those in the other chapters in this handbook, and the designer of record shall coordinate with the other project consultants to be sure that all aspects of the facility are effective and compatible. Architectural, electrical, and mechanical design considerations, as they relate to technology, are detailed herein; it is the technology designer of record’s responsibility to coordinate these considerations with the architect, electrical engineer, and mechanical engineer.
- 1.6. All design features must be weighed carefully for their initial cost, long-term maintenance cost and needs, durability, and their impact on the environment.
- 1.7. The information and “best practice” approaches described in this chapter are based on the belief that technology systems are similar to electrical power – a fundamental resource that should be readily available and easy to use, ubiquitous yet unobtrusive. Technology is a utility, a tool, and not an end in itself. With this in mind, technology systems for BIA justice and detention centers shall be easy to use and maintain, standards based, and consistent across all facilities.
- 1.8. Communication systems must be designed by a consulting and/or engineering firm with one or more registered communications distribution designers (RCDD) on staff, who are in turn responsible for the technology design. An RCDD is a technical designation given to individuals who demonstrate design proficiency with technology systems. Most technology consulting firms have staff members with an RCDD designation, as do some electrical engineering firms.
- 1.9. Audiovisual and security systems shall be designed by a consulting and/or engineering firm that can demonstrate that they have past experience in the design of projects that are similar in complexity. These demonstrated projects must have been designed within the last five years. Most technology consulting firms have staff members with such experience, as do some electrical

engineering firms. It is strongly recommended that work be performed under the supervision of a licensed professional engineer (PE).

**13000-2. Documents**

- 2.1. Technology systems shall be specified under their own division within the project specifications and shall be shown on T-series drawings. Some materials and equipment traditionally considered more electrical in nature, such as communications pathway infrastructure and telecommunications grounding/bonding, shall be specified in the electrical technology series of specifications (a sub-section of the technology specifications), and shall be shown on an ET-series of drawings.

**13000-3. Technology Systems Selection**

- 3.1. The type and complexity of technology systems, and/or whether a particular system is necessary, will depend largely on the function(s) and operation of the facility. A justice/detention center may include one, a select few, or all of the following functions:
  - 3.1.1. **Administration.** Administrative functions are typically found within the law enforcement area; however, they may be associated with the courts or detention areas. Administration includes general office and facility functions such as staff support, facility support, property building, and the perimeter of the facility. More specifically, administration can include offices, public building entrances, employee only entrances from public areas, parking lots, impound lots, fence lines, fitness rooms, training rooms, women's lockers and restrooms, men's lockers and restrooms, sleep rooms, secured records, evidence and property storage, telecommunication rooms, server rooms, data center rooms, communications/911 call center (dispatch), radio rooms, radio towers, and computer training rooms.
  - 3.1.2. **Law Enforcement.** Law Enforcement, when used within Chapter 13, includes criminal investigation and patrol activities. The law enforcement space can include offices and conference rooms for law enforcement activities, firearm and ammunition storage, booking, interview rooms, sallyports, communications (dispatch) center, Security Management System (SMS), and telecommunications and server rooms.
  - 3.1.3. **Courts.** Courts includes the offices and conference rooms for judges, prosecutors, and defense attorneys, jury briefing and deliberation spaces, law library, clerk spaces, courtrooms, and telecommunications and server rooms.
  - 3.1.4. **Detention.** The detention function is comprised of holding cells, day rooms, interview rooms, video arraignment, control room, detainee showers, safety cells, sallyports, inmate property storage, visitation rooms, medical exam rooms, telecommunications and detention control equipment rooms.

- 3.2. When more than one function is included within a facility, some of the spaces may be shared or located within the other functional area.

**13000-4. Technology Systems Construction**

- 4.1. It is recommended that the technology systems be constructed by a contractor directly subcontracted to the general contractor, not the electrical contractor. This avoids a layer of cost markup that is typically not necessary and also facilitates coordination among the various trades on the job site.

### 13010-1. Technology Systems Selection Matrix

1.1. The matrix in this section is intended to provide an overview of technology systems to be included in Justice/Detention facilities, and to aid in selecting the systems based upon specified criteria. The matrix is not intended to be all-inclusive, nor is it intended to be used to exclude a system should conditions clearly indicate a need for it. After applying the matrix to determine the applicable technology systems, the technology designer of record shall review the selected and excluded systems with the design team and BIA.

#### 1.2. How to Use the Matrix

- 1.2.1. Technology systems are listed in the left-hand column of the matrix, and the type of space is listed across the top of the matrix. A "•" in the intersecting cell indicates that the system is likely to be required and evaluation by the technology designer of record is required. Systems and features that require special justification for use are noted in the Special Case Justification column.
- 1.2.2. Coordination with other design disciplines is necessary to integrate technology systems into the facility. Inter-disciplinary coordination is across the top of the matrix and a "•" in a cell that intersects with the technology system indicates the need for design coordination.
- 1.2.3. The Technology Systems Selection Matrix is designed to be used in conjunction with, not exclusive of, this narrative. Together, these documents provide the guidelines by which technology systems shall be evaluated and selected.

### 13010-2. Selection Criteria

- 2.1. When specifying appropriate technology systems, the designer of record shall consider the following factors/criteria and the impact on each facility.
- 2.1.1. *Special Case Justification.* Some systems should be provided only on a case-by-case basis, based upon anticipated, historical, and/or local needs.
- 2.1.2. *Type.* The following types of facilities, functions and associated spaces are categorized in the Technology Systems Selection Matrix as follows:
- Administration
  - Law Enforcement
  - Courts
  - Detention. This handbook addresses detention standards for short-term holding (Tier I) facilities only defined in Section 1010.

The typical spaces found within these functional areas are described in Section 13000.



**2.1.3. Inter-disciplinary Coordination.** The disciplines indicted for coordination for each system are not intended to be all inclusive. Review system requirements with the design team.

**2.1.4. Ease of Use and Maintenance.** In addition to the above criteria, ease of use and maintenance of technology systems is also critical. Systems that require extensive training to use and/or highly skilled personnel to maintain shall be avoided to the extent possible. The technology systems ultimately selected for a justice/detention facilities shall be those that provide for optimal ease of use and maintenance while satisfying the stated performance criteria. In some cases, this may mean providing systems that are initially more costly, but that will have markedly lower maintenance costs or are substantially easier to use.

**Figure 13010-1: Technology Systems Selection Matrix**

| Technology System Selection Matrix                       |                            |                |                 |        |                  |               |                               |            |            |          |       |       |
|--|----------------------------|----------------|-----------------|--------|------------------|---------------|-------------------------------|------------|------------|----------|-------|-------|
| Technology System  | Special Case Justification | Type of Space  |                 |        |                  |               | Inter-discipline Coordination |            |            |          |       |       |
|  |                            | Administration | Law Enforcement | Courts | Detention-Tier I | Architectural | Structural                    | Mechanical | Electrical | Plumbing | Civil | Other |
| <b>13030 Communications Rooms</b>                        |                            |                |                 |        |                  |               |                               |            |            |          |       |       |
| Telecom Room(s) (TR)                                     |                            | •              | •               | •      | •                | •             | •                             | •          | •          | •        |       |       |
| Entrance Facility (EF)                                   |                            | •              | •               | •      | •                | •             | •                             | •          | •          | •        |       |       |
| Server Room (SR)   |                            | •              | •               | •      | •                | •             | •                             | •          | •          | •        |       |       |
| Data Center (DC)   | •                          |                |                 |        |                  | •             | •                             | •          | •          | •        |       |       |
| Detention Controls Equipment Room                        |                            |                |                 |        | •                | •             |                               |            | •          |          |       |       |
| Interview Control (Monitoring) Room                      |                            |                | •               |        |                  | •             |                               |            | •          |          |       |       |
| <b>13040 Communications Cabling System</b>               |                            |                |                 |        |                  |               |                               |            |            |          |       |       |
| <i>Backbone Cabling</i>                                  |                            |                |                 |        |                  |               |                               |            |            |          |       |       |
| Inside Plant   |                            |                |                 |        |                  |               |                               |            |            |          |       |       |
| Fiber, Copper, CATV Coax                                 |                            | •              | •               | •      | •                |               |                               |            |            | •        |       |       |
| Outside Plant (see Section 13070)                        |                            | •              | •               | •      | •                |               |                               |            |            |          |       |       |
| <i>Horizontal Cabling</i>                                |                            |                |                 |        |                  |               |                               |            |            |          |       |       |
| Category 6   |                            | •              | •               | •      | •                |               |                               |            | •          |          |       |       |
| CATV Coax  |                            | •              | •               | •      | •                |               |                               |            |            |          |       |       |
| <b>13050 Communications Pathway System</b>               |                            |                |                 |        |                  |               |                               |            |            |          |       |       |
| Device Box/Conduit to accessible space                   |                            | •              | •               | •      |                  | •             |                               |            | •          |          |       |       |
| Floor Box/Poke-thru                                      |                            | •              | •               | •      |                  | •             | •                             |            | •          |          |       |       |
| <i>Main Pathway</i>                                      |                            |                |                 |        |                  |               |                               |            |            |          |       |       |
| Cable Tray   |                            | •              | •               | •      |                  | •             |                               | •          | •          | •        |       |       |
| Conduit  |                            | •              | •               | •      | •                | •             |                               | •          | •          |          |       |       |
| J-Hooks/Straps   |                            | •              | •               | •      |                  | •             |                               | •          |            |          |       |       |
| Sleeves  |                            | •              | •               | •      |                  | •             | •                             |            | •          |          |       |       |
| Firestopping Pathway Devices                             |                            | •              | •               | •      |                  | •             | •                             |            | •          |          |       |       |
| Outside Plant Pathway                                    |                            | •              | •               | •      | •                | •             | •                             |            | •          |          | •     |       |
| <b>13060 Communications Grounding and Bonding System</b> |                            |                |                 |        |                  |               |                               |            |            |          |       |       |
|  |                            | •              | •               | •      | •                |               |                               |            | •          |          |       |       |
| <b>13070 Outside (Service Provider) Connectivity</b>     |                            |                |                 |        |                  |               |                               |            |            |          |       |       |
| CATV   |                            | •              | •               | •      | •                |               |                               |            | •          |          | •     | •     |
| Satellite  |                            | •              | •               | •      | •                | •             |                               |            | •          |          |       |       |
| PCS (Cell Phone)   | •                          |                |                 |        |                  | •             |                               |            | •          |          |       |       |
| Data (Internet)  |                            | •              | •               | •      | •                |               |                               |            |            |          | •     | •     |
| Voice (Dial Tone)  |                            | •              | •               | •      | •                |               |                               |            |            |          | •     | •     |
| <b>13080 Network/Phone Equipment</b>                     |                            |                |                 |        |                  |               |                               |            |            |          |       |       |
| Data Networking Equipment (PoE Capable)                  |                            | •              | •               | •      | •                |               |                               |            |            |          |       |       |
| Telephone system (VoIP)                                  |                            | •              | •               | •      | •                |               |                               |            |            |          |       |       |
| Wireless Networking Equipment                            | •                          |                |                 |        |                  |               |                               |            |            |          |       |       |

| Technology System Selection Matrix      |                            |                |                 |        |                  |                               |            |            |            |          |       |       |
|---|----------------------------|----------------|-----------------|--------|------------------|-------------------------------|------------|------------|------------|----------|-------|-------|
| Technology System                       | Special Case Justification | Type of Space  |                 |        |                  | Inter-discipline Coordination |            |            |            |          |       |       |
|   |                            | Administration | Law Enforcement | Courts | Detention-Tier I | Architectural                 | Structural | Mechanical | Electrical | Plumbing | Civil | Other |
| <b>13090 Low Voltage</b>                |                            |                |                 |        |                  |                               |            |            |            |          |       |       |
| In-building Wireless                    | •                          |                |                 |        |                  |                               |            |            |            |          |       |       |
| <i>Intercom</i>                         |                            |                |                 |        |                  |                               |            |            |            |          |       |       |
| Facility (part of telephone system)     |                            | •              | •               | •      | •                |                               |            |            |            |          |       |       |
| Visitation                              |                            |                |                 |        | •                |                               |            |            |            |          |       |       |
| Public Address                          |                            | •              | •               | •      | •                | •                             |            | •          | •          |          |       |       |
| Clocks                                  |                            | •              | •               | •      | •                | •                             |            |            |            |          |       |       |
| <b>13100 Security Systems</b>           |                            |                |                 |        |                  |                               |            |            |            |          |       |       |
| <i>Access Control</i>                   |                            |                |                 |        |                  |                               |            |            |            |          |       |       |
| Entryways - Exterior                    |                            | •              | •               | •      | •                | •                             |            |            |            |          |       |       |
| Exterior                                |                            | •              | •               | •      | •                | •                             |            |            |            |          |       |       |
| Impound Lot                             |                            |                | •               |        |                  | •                             |            |            |            |          |       |       |
| Parking Lots                            |                            | •              | •               | •      | •                | •                             |            | •          |            |          | •     |       |
| Passageways-Interior                    |                            | •              | •               | •      | •                | •                             |            |            |            |          |       |       |
| Perimeter                               |                            | •              | •               | •      | •                | •                             |            |            |            |          |       |       |
| Protected Spaces                        |                            | •              | •               | •      | •                | •                             |            |            |            |          |       |       |
| Restricted Areas                        |                            | •              | •               | •      | •                | •                             |            |            |            |          |       |       |
| <i>Video Surveillance System</i>        |                            |                |                 |        |                  |                               |            |            |            |          |       |       |
| Entryways - Exterior                    |                            | •              | •               | •      | •                | •                             |            |            |            |          |       |       |
| Exterior                                |                            |                | •               | •      | •                | •                             |            |            |            |          |       |       |
| Impound Lot                             |                            |                | •               |        |                  | •                             |            |            |            |          | •     |       |
| Parking Lots                            |                            | •              | •               | •      | •                | •                             |            | •          |            |          | •     |       |
| Passageways-Interior                    |                            |                | •               | •      | •                | •                             |            |            |            |          |       |       |
| Perimeter                               |                            | •              | •               | •      | •                | •                             |            | •          |            |          | •     |       |
| Protected Spaces                        |                            | •              | •               | •      | •                | •                             |            |            |            |          |       |       |
| Public Areas                            |                            | •              | •               | •      | •                | •                             |            |            |            |          |       |       |
| Restricted Areas                        |                            | •              | •               | •      | •                | •                             |            |            |            |          |       |       |
| <i>Intrusion Detection</i>              |                            |                |                 |        |                  |                               |            |            |            |          |       |       |
| Impound Lot                             |                            |                | •               |        |                  | •                             |            | •          |            |          | •     |       |
| Perimeter                               |                            | •              | •               | •      | •                | •                             |            | •          |            |          | •     |       |
| Protected Spaces                        |                            | •              | •               | •      | •                | •                             |            |            |            |          |       |       |
| Restricted Areas                        |                            | •              | •               | •      | •                | •                             |            |            |            |          |       |       |
| <i>Duress</i>                           |                            |                |                 |        |                  |                               |            |            |            |          |       |       |
| Fixed                                   |                            | •              | •               | •      | •                | •                             |            |            |            |          |       |       |
| Mobile                                  |                            |                | •               |        | •                | •                             |            |            |            |          |       |       |
| <i>Detention</i>                        |                            |                |                 |        |                  |                               |            |            |            |          |       |       |
| Detention Door Controls                 |                            |                |                 |        | •                | •                             |            | •          |            |          |       |       |
| Detention Door Monitoring               | •                          |                |                 |        | •                | •                             |            |            |            |          |       |       |
| <i>Detention Intercom</i>               |                            |                |                 |        |                  |                               |            |            |            |          |       |       |
| General Detention                       |                            |                |                 |        | •                | •                             |            | •          |            |          |       |       |
| Movement Control                        |                            |                |                 |        | •                | •                             |            | •          |            |          |       |       |
| Detention Paging                        |                            |                |                 |        | •                | •                             |            |            |            |          |       |       |
| Detainee Duress                         |                            |                |                 |        | •                | •                             |            | •          |            |          |       |       |
| Detention Video Surveillance            |                            |                |                 |        | •                | •                             |            | •          |            |          |       |       |
| Detention Perimeter Detection           |                            |                |                 |        | •                | •                             |            |            |            | •        |       |       |
| <i>Security Management System (SMS)</i> | •                          |                |                 |        | •                | •                             |            | •          |            |          |       |       |
| <i>Metal Detector</i>                   |                            |                |                 |        |                  |                               |            |            |            |          |       |       |
| Fixed                                   |                            |                | •               | •      | •                | •                             |            | •          |            |          |       | •     |
| Mobile                                  |                            |                |                 |        |                  |                               |            |            |            |          |       |       |
| Portable                                |                            |                | •               | •      | •                | •                             |            |            |            |          |       |       |
| <i>X-Ray Scanner</i>                    |                            |                |                 | •      | •                | •                             |            | •          |            |          |       | •     |

| Technology System Selection Matrix    |                            |                |                 |        |                  |                               |            |            |            |          |       |       |
|---------------------------------------|----------------------------|----------------|-----------------|--------|------------------|-------------------------------|------------|------------|------------|----------|-------|-------|
| Technology System                     | Special Case Justification | Type of Space  |                 |        |                  | Inter-discipline Coordination |            |            |            |          |       |       |
|                                       |                            | Administration | Law Enforcement | Courts | Detention-Tier I | Architectural                 | Structural | Mechanical | Electrical | Plumbing | Civil | Other |
| <b>13110 Room Technology Systems</b>  |                            |                |                 |        |                  |                               |            |            |            |          |       |       |
| <i>Audio</i>                          |                            |                |                 |        |                  |                               |            |            |            |          |       |       |
| Sound Reinforcement                   |                            |                |                 | •      |                  | •                             |            |            | •          |          |       |       |
| Signal Sources                        |                            | •              | •               | •      |                  |                               |            |            |            |          |       |       |
| Sidebar Noise-masking                 |                            |                |                 | •      |                  |                               |            |            |            |          |       |       |
| Recording                             |                            |                | •               | •      | •                |                               |            |            |            |          |       |       |
| Assisted Listening                    |                            |                |                 | •      |                  | •                             |            |            | •          |          |       |       |
| Language Translation                  |                            |                |                 | •      |                  |                               |            |            |            |          |       |       |
| <i>Video</i>                          |                            |                |                 |        |                  |                               |            |            |            |          |       |       |
| Distribution                          |                            |                | •               | •      | •                |                               |            |            |            |          |       |       |
| Signal Sources                        |                            | •              | •               | •      |                  |                               |            |            |            |          |       |       |
| Display                               |                            |                |                 |        |                  |                               |            |            |            |          |       |       |
| Projection                            |                            |                | •               | •      |                  | •                             |            |            | •          |          |       |       |
| Projection Screens                    |                            |                | •               | •      |                  | •                             |            |            | •          |          |       |       |
| Flat Panel Displays                   |                            |                | •               | •      | •                | •                             |            |            | •          |          |       |       |
| Recording                             |                            |                | •               | •      | •                | •                             |            |            | •          |          |       |       |
| Remote Arraignment                    |                            |                | •               | •      | •                | •                             |            |            | •          |          |       |       |
| Tele/videoconferencing                |                            | •              | •               | •      |                  | •                             |            |            | •          |          |       |       |
| Control                               |                            |                |                 | •      |                  |                               |            |            | •          |          |       |       |
| Interview Rooms                       |                            |                | •               |        |                  | •                             |            |            | •          |          |       |       |
| Interview Controls (Monitoring) Rooms |                            |                | •               |        |                  | •                             |            |            | •          |          |       |       |
| Fitness                               |                            | •              | •               |        | •                | •                             |            |            | •          |          |       | •     |
| <b>13120 Radio System</b>             |                            |                | •               |        | •                |                               |            |            |            |          |       | •     |
| <b>13130 911 Call Center/Dispatch</b> |                            |                | •               |        |                  | •                             |            |            | •          |          |       | •     |

**13020-1. General**

- 1.1. For technology design, follow all applicable current codes, standards, and laws. For a more general list of codes and standards that apply to BIA Justice and Detention facilities, refer to Chapter 1, “General Information.” During design, report any required deviations from codes and standards to the Contracting Officer.
- 1.2. Where two codes, standards, or laws are applicable to the topic under review, use the more conservative or more stringent. Consult with the BIA Office of Facilities Management and Construction (OFMC) to resolve any questions or conflicts regarding application of codes and standards.
- 1.3. Standards for technology systems shall primarily consist of the Telecommunications Industry Association/Electronics Industries Alliance (TIA/EIA) telecommunications standards and the applicable standards published by the Institute of Electrical and Electronics Engineers (IEEE). Guidelines based upon these standards shall also be used, the most notable of which are the materials published by Building Industry Consulting Service International (BICSI).
- 1.4. Standards-based systems will enable the BIA to make use of consistent training and operations and maintenance (O&M) information across all facilities, and in turn enable personnel moving between justice and detention facilities to immediately use and/or maintain the technology systems with little or no additional training. Technical knowledge will be consistent and thus more readily available, allowing staff to share knowledge between facilities and to provide each other with assistance when necessary.
- 1.5. In addition to the standards guidelines noted above and listed below, all technology installations shall comply with any pertinent national, state, local, or tribal regulations.

**13020-2. Applicable Codes and Standards**

- 2.1. The design criteria shall comply with federal, state, county, city, tribal and other local codes, requirements and guidelines contained in the following:
  - ANSI J-STD-607A Commercial Building Grounding and Bonding Requirements for Telecommunications
  - ANSI S12.60 Acoustical Performance Criteria, Design Requirements, and Guidelines for Schools
  - BICSI *Customer-Owned Outside Plant Design Manual*
  - BICSI *Information Transport Systems Installation Manual*
  - BICSI *Telecommunications Distribution Methods Manual*
  - EIA Standard SE-101-A Amplifiers for Sound Equipment

- EIA Standard SE-103 Speakers for Sound Equipment
- EIA Standard SE-104 Engineering Specifications for Amplifiers for Sound Equipment
- FCC Part 68 Connection of Terminal Equipment to Telephone Network
- IEC 60268-5 2003-5 Speakers
- IEEE 802.3 (series) Local Area Network Ethernet Standards
- IEEE C62.41 Recommended Practice for Surge Voltages in Low-Voltage AC Power Circuits
- NFPA 75 Protection of Electronic Computer and Data Processing Equipment
- NFPA 78 Lightning Protection Code
- NFPA 90A Standard for the Installation of Air-Conditioning and Ventilating Systems
- TIA/EIA 568-B – Commercial Building Telecommunications Cabling Standard (Parts 1,2, & 3)
- TIA/EIA 569-B – Commercial Building Standard for Telecommunications Pathways and Spaces
- TIA/EIA-606 Administration Standard for Commercial Telecommunications Infrastructure
- TIA/EIA-758 Customer-Owner Outside Plant Telecommunications Cabling Standard
- TIA/EIA 862 – Building Automation Systems Cabling Standard for Commercial Buildings
- NFPA 101 Life Safety Code, Requirements for Emergency Power Sources for Remote Power-Unlocking Capability
- NFPA 731 Standard for the Installation of Electronic Premises Security Systems
- UL 294 Access Control System Units
- UL 467 Grounding and Bonding Equipment
- UL 1449 Transient Voltage Surge Suppressors
- UL 1480 Standard for Speakers for Fire Alarm, Emergency, and Commercial and Professional Use based on the fire testing criteria found in ANSI/UL263
- UL 2043: Standard for Fire Test for Heat and Visible Smoke Release for Discrete Products and Their Accessories Installed in Air-Handling Spaces

**13020-3. Organizations**

**3.1.** The technology designer of record shall also be familiar with and apply the relevant standards of practice observed by the following organizations:

- AES-Audio Engineering Society
- ATSC-Advanced Television Systems Committee
- NENA-National Emergency Number Association
- NRTL-Nationally Recognized Testing Laboratories
- InfoComm International
- ISO-International Standards Organization
- NAB-National Association of Broadcasters
- SMPTE-Society of Motion Picture and Television Engineers

**13030-1. General**

- 1.1. Communications rooms primarily consist of telecommunications rooms (TRs) and entrance facilities (EFs); some justice and detention facilities will also have server rooms (SR) or a data center (DC).
- 1.2. Properly sized, located, and provisioned communications rooms are critical to the ability of the facility to grow with and accommodate technology systems as those systems change over time.
- 1.3. Refer to the *BIA Justice/Detention Facilities Space Templates* for typical layouts of these spaces.

**13030-2. Telecommunications Rooms**

- 2.1. Telecommunications rooms provide a connection point between backbone and horizontal (outlet) cabling, and house equipment for the data network, voice, and other communications systems, such as current or future cable television (CATV), alarms, security, access control, and building automation systems. TRs were formerly known as intermediate distribution frame (IDF) and main distribution frame (MDF) rooms.
- 2.2. Every facility shall include a primary TR. Facilities requiring additional TRs (based upon size) shall include 1 or more secondary TRs. The type and quantity of equipment racks shall vary depending upon whether the TR is primary or secondary.
- 2.3. The 2 long walls of each TR shall be covered with 8 feet high, ¾ inch thick, fire treated backboards, installed 1 foot above the floor. Ladder rack shall be installed around the perimeter of the room, offset 6 inches from each wall. An additional ladder rack shall be centered above the equipment racks. The ladder rack shall be installed between 4 and 6 inches above the equipment rack/frame height. Ladder rack placement shall be coordinated with the room door and lighting.

**2.3.1. Equipment Racks**

- 2.3.1.1. Primary TR. Typically, 2 2-post, free-standing equipment racks and 2 4-post free-standing equipment frames shall reside within a primary TR (1 rack for station cabling, 1 rack for backbone cabling, and 2 equipment frames for equipment) centered longitudinally within the room. The first rack in the row shall abut one of the short walls, offset by six inches. General orientation of the racks and frames are shown in Figure 13030-1. The primary TR shall have space for 1 future equipment rack or frame to be installed at the end of the row. However, this configuration may change depending upon the size of the primary TR, whether the primary TR is also serving as an EF or SR, and the size and amount of equipment to be installed within the room. The technology designer of record shall determine

the type and amount of equipment to be installed in the primary TR before finalizing the size.

- 2.3.1.2. Secondary TR. Typically, 3 2-post, free-standing equipment racks shall reside within a secondary TR (1 for station cabling, 1 for backbone cabling, and 1 for equipment) centered longitudinally within the room. The first rack in the row shall abut one of the short walls, offset by six inches. General orientation of the racks is shown in Figure 13030-1. This configuration may change depending upon the size of the TR and the size and amount of equipment to be installed within it.

#### 2.4. Architectural Considerations

- 2.4.1. It is preferable to locate TRs in building core areas, and in areas more central to the space to be served. Ceiling space within TRs shall be left open as false/suspended ceilings are neither required nor desirable. TRs shall not be co-located within or otherwise share space with mechanical, electrical, or janitorial spaces. Ideally, and to the extent possible, the long wall of the TR shall not be the same wall as that of an electrical room. Doors shall swing out of the room (rather than into the room) in order to maximize the use of the space within the room, and access to the TR should be directly from a hallway (i.e. not through another room – such as an Electrical Room) Fire protection, where required, shall be either a wet pipe system or a dry pipe system. If it is a wet pipe system, wire cages shall be installed around sprinkler heads to prevent accidental operation. TRs shall be located so as to eliminate any threat of flooding.
- 2.4.2. In general, a minimum of 1 TR shall be required on each floor, with each TR serving a radius of approximately 150 feet. A good rule of thumb is to provide 1 TR per 25,000 square feet, assuming that each TR is generally centered in the area it is to serve. Given this restriction, as well as program restrictions that may limit the locations available to place a TR, it is possible that secondary TRs may be required. For multi-floor facilities, TRs shall be stacked to eliminate the costly and difficult-to-coordinate horizontal raceway that would be necessary between nonstacked TRs.
- 2.4.3. A primary TR shall not be located on an exterior wall or adjacent to an elevator or mechanical shaft, if avoidable.
- 2.4.4. *Sizing*
  - 2.4.4.1. TR shall be sized based on the guideline shown in Figure 13030-1.
  - 2.4.4.2. Primary TR. The minimum size for a primary TR (without co-located EF) is 10 feet by 15 feet, with walls to structure. Refer to the *BIA Justice / Detention Facilities Space Templates* for a typical layout of this space.



- 2.4.4.3.** Primary TR with Co-Located EF. The minimum size for a primary TR with EF is 10 feet by 15 feet, with walls to structure, and subject to specific service provider requirements. A larger space may be required for primary TRs that are also serving as SRs.
- 2.4.4.4.** Secondary TR. The minimum size for a standard secondary TR is 10 feet by 12 feet, with walls to structure. Refer to the *BIA Justice / Detention Facilities Space Templates* for a typical layout of this space.

**Figure 13030-1: Telecommunications/Server Room Sizing Guideline**

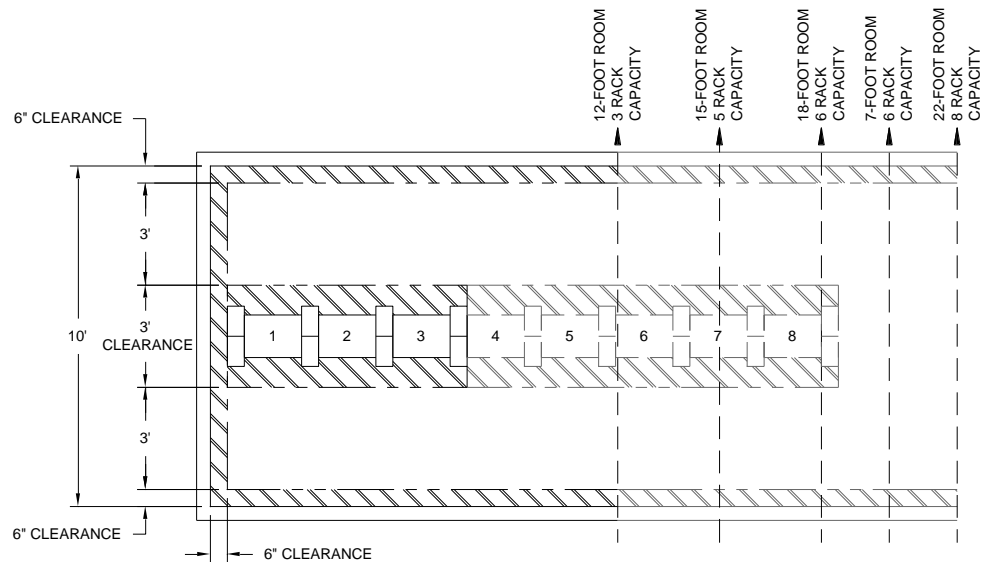

## 2.5. Electrical Considerations

- 2.5.1.** The technology designer of record shall work with the owner to determine the projected and future expansion loads for each TR, and provide that information to the electrical engineer for load sizing. The electrical sizing for the TR shall be based upon that anticipated load. Preference shall be given to supply 208 VAC where possible to improve power supply efficiencies.
- 2.5.2.** At a minimum, a TR shall be provided with 120 VAC convenience electrical receptacles on each wall, and 2 20-amp dedicated receptacles for each equipment rack mounted on unistrut above the racks (e.g., a TR with 3 equipment racks would have 6 20-amp dedicated receptacles for the racks). In addition, the primary TR shall have 4 dedicated 30-amp receptacles, evenly spaced above the rack locations and mounted on unistrut (30-amp receptacle types shall vary depending upon equipment requirements and shall be coordinated with the owner prior to specification). A dedicated electrical panel shall be located within and serve each TR.

- 2.5.3. Provision shall be made for additional circuits and receptacles as necessary for equipment to be mounted on the walls and/or for other equipment to be located within the room. Such equipment could consist of fire alarm panels, door control power supplies, audiovisual equipment, etc. Provision shall also be made for future electrical capacity within the room.
- 2.5.4. If a building generator and/or building UPS will be provided for the facility, half of the circuits in the TR shall be fed from the generator and/or building UPS.
- 2.5.5. Wall electrical receptacles shall be flush mounted with the backboard. Surface-mounted electrical receptacles interfere with the mounting of horizontal ladder racking within the room and restrict the surface area available for wall-mounting communications equipment.
- 2.5.6. One or more rack-mountable UPS units shall be provided in every TR, and shall be sized based upon maximum anticipated load. The technology designer of record shall work with the BIA and electrical engineer to determine the sizing of the UPS unit(s).

## 2.6. Environmental Considerations

- 2.6.1. The technology designer of record shall work with the BIA to determine the projected and future heat loads for a given TR, and provide that information to the mechanical engineer for heat load sizing. The cooling requirements for the TR shall be based upon that load and shall be provided at all times, without interruption.
- 2.6.2. Positive air pressure shall be required. Temperature shall be maintainable at a maximum of 75°F and humidity shall range between 30 percent and 55 percent, if possible.

## 13030-3. Entrance Facility

### 3.1. General

- 3.1.1. The entrance facility provides a connection point between the backbone cabling system within the building and cabling exiting the building. Communications conduits from outside the building shall be terminated in the EF. The EF may also house service provider and/or other electronic equipment connected to cabling from outside the building. Generally only 1 EF exists per building.
- 3.1.2. If the EF is co-located within a primary TR, an additional free-standing equipment rack beyond those specified above for the primary TR may be required. If the EF is separate from the primary TR, only 1 or 2 free-standing equipment racks shall be required. Remaining space within the room shall be reserved for service provider and/or other equipment connected to cabling from outside the building.

**3.2. Architectural Considerations**

- 3.2.1.** If the EF is not co-located within a TR, the EF typically does not need to be larger than a standard TR, and can sometimes be smaller (but no smaller than 8 feet wide). If co-located within a TR, the EF may need to be larger than a normal TR, while other architectural requirements are the same as those specified above for TRs.

**3.3. Electrical and Environmental Considerations**

- 3.3.1.** Electrical and environmental requirements are the same as those specified for TRs above, although service providers may have nonstandard requirements that the technology designer of record shall coordinate with and accommodate as necessary.

**13030-4. Server Room****4.1. General**

- 4.1.1.** The SR provides a location for housing communications equipment such as servers, storage devices, PBX equipment, and headend equipment for other communications systems. In addition to the criteria shown in the “Technology Systems Selection Matrix” in Section 13010, a SR shall be required where the projected number of server cabinets and equipment racks is 8 or more in a single row, or where a facility will be serving multiple functions. If more than 1 row of racks is necessary, than the standards for a DC apply.
- 4.1.2.** If the SR is co-located within a TR or EF, additional free-standing equipment cabinets beyond those specified above for the TR or EF may be required.

**4.2. Architectural Considerations**

- 4.2.1.** The architectural considerations for a TR shall also apply to a SR.
- 4.2.2. *Sizing.*** The size of the SR shall be based on the guideline shown in Figure 13030-1 and shall depend upon the size and quantity of the equipment to be located within the SR, plus future expansion. The SR design shall assume that all servers shall be rack-mountable. The minimum size for an SR is 10 feet by 22 feet, with walls to structure. Refer to the *BIA Justice / Detention Facilities Space Templates* for a typical layout of this space.

- 4.3. Electrical and Environmental Considerations.** Electrical and environmental requirements are the same as those specified for TRs above.

**13030-5. Data Center****5.1. General**

- 5.1.1. There may be a need to consolidate SRs from either multiple functions or buildings into a single location. This could be due to insufficient space in the different functional areas or locations, or the need to more efficiently administer equipment from a central location. A DC can provide a controlled and secure space for a large quantity of equipment such as servers, storage devices, PBX equipment, and head-end equipment.
- 5.1.2. The need for a DC shall be determined by the design team during the design process.

**5.2. Architectural Considerations**

- 5.2.1. The architectural considerations for a TR shall also apply to a DC.
- 5.2.2. Placement of the ladder rack along the DC walls shall be evaluated by the technology designer of record to determine the most effective and efficient application.
- 5.2.3. *Sizing*. The size of the DC shall depend upon the size and quantity of the equipment to be located within the SR, plus future expansion.
- 5.2.4. The cabling infrastructure in the DC shall be served from overhead.
- 5.2.5. A raised floor system is not desirable and shall not be used unless there is a compelling reason to do so.

**5.3. Electrical Considerations**

- 5.3.1. A DC shall have redundant power in order to provide reliable and continuous operation. If the building is equipped with a generator, power from the generator shall be provided to the DC to support environmental controls as well as equipment needed to support critical services provided by the DC. The UPS for the DC shall be a centralized system located in an adjacent room or integrated as part of the cabinet infrastructure.
- 5.3.2. The technology designer of record shall work with the owner to determine the electrical loads associated with projected future expansion within a given DC, and provide that information to the electrical engineer for load sizing. The electrical sizing for the DC shall be based upon that load. Preference shall be given to supply 208VAC where possible to improve power supply efficiencies.

**5.4. Environmental Considerations**

- 5.4.1. The environment considerations for a TR shall also apply to a DC. The environmental requirements shall depend upon the size and quantity of the equipment to be located within the DC, plus future expansion. Cooling shall be provided by computer room air conditioning (CRAC) units and be redundant. The designer of record shall work with the BIA to determine

the projected and future heat loads for the DC, and provide that information to the mechanical engineers for heat load sizing.

#### **5.5. Special Considerations for Communications Cabling**

- 5.5.1.** A communications cabling system within the DC shall be required. This system is similar in concept to the communications cabling serving the building at large (see Section 13040, “Communications Cabling”), albeit on a much smaller scale. The communications cabling within the DC is used for connecting equipment in that room to other equipment in the room.

#### **13030-6. Detention Controls Equipment Room**

- 6.1.** Refer to Section 13100 for design criteria and architectural, electrical, and environment considerations.

#### **13030-7. Interview Control (Monitoring) Room**

- 7.1.** Refer to Section 13110 for design criteria and architectural, electrical, and environmental considerations.

**13040-1. General**

- 1.1. The communications cabling system shall be the cabling system upon which most (if not all) common communications signals shall be transmitted. The system shall be manufactured by an end-to-end manufacturer – i.e., the same manufacturer shall produce all cabling (copper and fiber) and connectors, terminations, and terminating equipment. The contractor installing the system must be a manufacturer-backed and approved installer, able to provide the manufacturer's extended (20-year or 25-year) application, installation, and product assurance warranties. The cabling system shall be tested by the contractor and certified by the manufacturer.

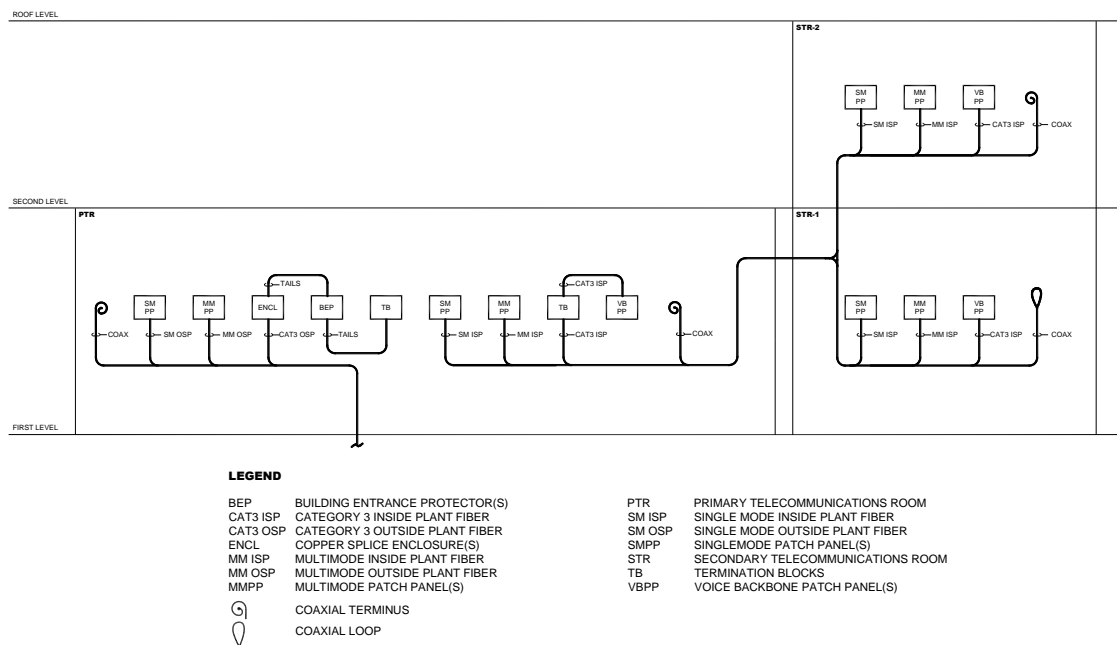
**Figure 13040-1: Sample Riser Diagram****13040-2. Backbone Cabling****2.1. Inside the Building (Inside Plant)****2.1.1. General**

- 2.1.1.1. Backbone cabling connects communications rooms to one another in a star topology. The backbone cabling system shall consist of single-mode fiber, multimode fiber, multi-pair copper, and coaxial cable (for CATV) backbone.

**Figure 13040-2: Typical Primary TR Rack Elevations**

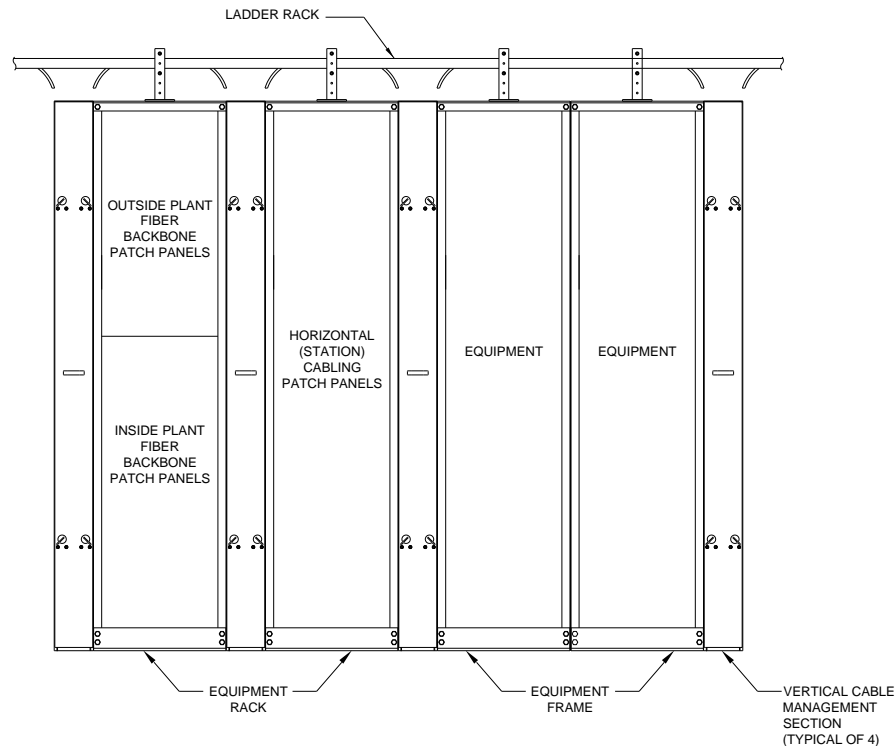

### 2.1.2. *Fiber Backbone Cabling*

**2.1.2.1.** Fiber backbone cable shall be used to distribute digital services between telecommunications rooms (TR), the entrance facility (EF), and the server room (SR) or data center (DC). Fiber backbone cable shall terminate on patch panels in the equipment racks within the TRs, EF, and SR or DC.

**2.1.2.2.** The minimum fiber backbone size shall be 12-strand 50/125 micron laser optimized multimode and 6-strand single-mode fiber. The technology designer of record shall meet with the owner to coordinate the final quantity of optical fibers based upon site-specific requirements.

### 2.1.3. *Multipair Copper Backbone Cabling*

**2.1.3.1.** Multipair copper backbone cables shall be provided for voice/analog-grade communications. These backbone cables shall be terminated on 110-style termination (wiring) blocks in the primary TR and on patch panels in the secondary TRs and SR or DC. The technology designer of record shall coordinate with the BIA to determine the numbers of pairs per port required for the multipair copper backbone cable termination on patch panels. The minimum copper backbone size shall be 25-pair, but shall be sized according to the number of voice-grade signals to be served.

**Figure 13040-3: Typical Secondary TR Rack Elevations**

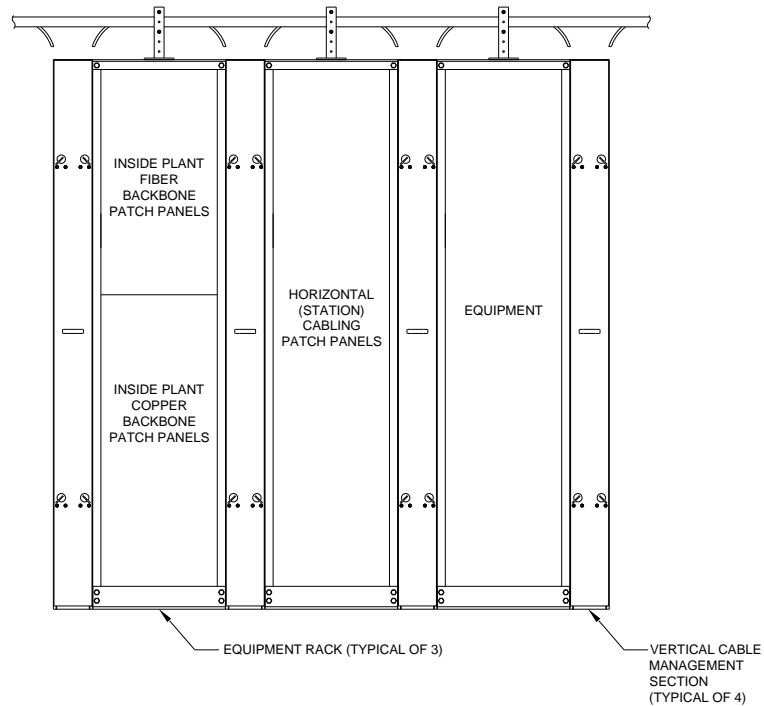

**2.1.4. Coaxial Backbone Cabling**

|                 |  |
|-----------------|--|
| Question/Issue: | What is the CATV bandwidth requirement?  |
| Recommendation: | 1GHz   |
| Justification:  | Typical designations are 550 MHz, 860 MHz, 1 GHz and 2 GHz. Generally, 1 GHz adequately supports CATV analog and digital channels. |

**2.1.4.1.** Coaxial cable shall be used to distribute CATV signals. The technology designer of record shall coordinate with the CATV service provider to determine coaxial termination and hardware requirements. Minimum CATV distribution bandwidth requirement shall be 1 GHz. Typical coaxial backbone cable shall be Series 11 for short distances and 0.500 semi-flex or hardline for greater distances.

**2.2. Outside the Building (Outside Plant)**

**2.2.1.** Outside plant (OSP) backbone cabling shall connect multiple facilities together, or to service providers if the service providers are not providing their own cabling into the facility (see Section 13070, “Outside Connectivity”). OSP cables shall typically consist of fiber, copper, and



coaxial cabling. Where building-to-building feeds are required, each new facility shall be connected with a minimum of 100-pair copper feeder cable, 12-strand 50/125 micron laser optimized multimode fiber, and 24-strand single-mode fiber feeder cables. If coaxial CATV is available, CATV cabling for the new facility shall be consistent with the existing cabling (typically a minimum of 0.875 hardline). The technology designer of record shall coordinate with the local service provider.

### 13040-3. Horizontal (Station/Outlet) Cabling

#### 3.1. General

- 3.1.1. Station/outlet cabling for data and voice shall consist of Category 6 cable from each outlet to the outlet's assigned TR. There shall be no differentiation between data and voice cabling and ports (i.e., a "universal" cabling system shall be designed); port utilization shall be visually defined at the patch panel by color-coded patch cords (white for voice, blue for data, yellow or green for special circuits), and if desired, at the outlet by the use of faceplate/port icons. All horizontal cabling shall be terminated sequentially on patch panels in equipment racks in the TRs.
- 3.1.2. Cabling for CATV shall consist of RG6 coax cabling, unless otherwise specified, from each outlet to the outlet's assigned TR. CATV cabling shall terminate on a wall field area reserved for CATV in each outlet's assigned TR. The connectors used to terminate the cable shall be a standard "F" type connector.
- 3.1.3. Station cabling shall utilize the raceway/pathway system described in Section 13050, "Communications Pathways."
- 3.1.4. Station outlets shall also be provided for specialized equipment requiring voice/data support (e.g., fire alarm, elevator, HVAC, wireless access points, etc.).
- 3.1.5. A typical outlet shall consist of 2 ports, and a typical wall phone shall be served with 1 port.
- 3.1.6. A wireless network (see Section 13080, "Network/Phone Equipment") may be required to provide coverage throughout some or all of the facility. Station cabling shall be provided for the wireless access points required for this network.
- 3.1.7. CATV outlets shall be provided in lunch rooms, private offices, conference rooms, copy rooms, executive offices, fitness rooms, and other areas where access to news and other information may be necessary.

#### 3.2. Specific Requirements

- 3.2.1. *Offices*. Single-occupant offices shall be served with a minimum of 2 2-port outlets. Cubicle areas, if present, shall each be served with 2 2-port outlet.

- 3.2.2. Conference Rooms.** Conference rooms shall be served with convenience outlets on the walls as well as outlets located in the conference room tables as required. In addition, each conference room shall be served with 1 CATV outlet.
- 3.2.3. Training Room.** Training rooms shall be served with convenience outlets on the walls as well as outlets located for training equipment as required. The training room may be designated to serve as a regional emergency operations center. If the training room is designated, data outlets shall be added to the training room to accommodate any additional requirements of the emergency operations center. The designer of record shall coordinate with the BIA to determine additional requirements of the emergency operations center.
- 3.2.4. Courtroom.** Courtrooms shall be served with convenience outlets on the walls, as well as outlets for the judge(s), court reporter, and attorneys. Outlets for other supporting systems may also be required (e.g., video conferencing, video cameras, etc.).

#### **13040-4. Labeling Scheme**

- 4.1.** An identification and administration system shall be employed to identify and label communications infrastructure, including passive equipment (copper, fiber, and coaxial cables, termination hardware, equipment rack/frames/cabinets, etc.). Labels shall be unique, machine-generated, and permanent. The labeling/identification system shall conform to the TIA/EIA-606 standard and comply with the BIA's requirements. The technology designer of record shall coordinate the final labeling scheme with the owner.

**13050-1. General**

- 1.1. Like communications rooms, a properly designed and sized communications pathway system is critical to a facility's ability to accommodate future technological change, particularly with regard to its support of the communications cabling system.

**13050-2. Conduit to Accessible Ceiling Space**

- 2.1. The cable pathway serving the outlets within the facility shall consist of 1-inch (minimum) conduit raceway (with bushing) from the outlet device box to accessible ceiling space. Each device box shall have a dedicated conduit to the ceiling (i.e., "daisy chaining" of device boxes is not acceptable).

**13050-3. Device Boxes**

- 3.1. Outlet device boxes shall be 4-11/16-inch by 4-11/16-inch, deep style, with mud ring. Surface raceway (such as Wiremold) shall be avoided to the extent possible in new facilities, but may be provided where no other option is available.

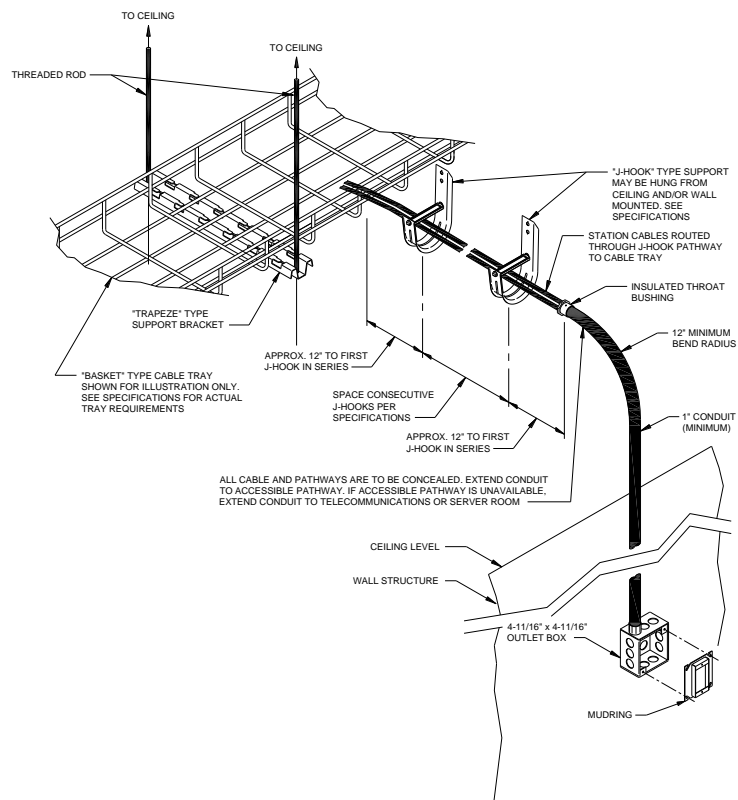
**Figure 13050-1: Typical Communications Pathway (Device Box to Cable Tray)**

#### 13050-4. Floor Boxes and Poke-Through Devices

- 4.1. The use of floor box and/or poke-through devices shall be avoided to the extent possible, but may be provided where no other option is available. These devices will typically share space with power and shall be flush-mounted. Conduits feeding these devices shall be fed either in or under the slab (depending on the conduit size and slab thickness for slab-on-grade installations) or fed from the ceiling space of the floor below.

#### 13050-5. Main Pathway

- 5.1. The cable tray system shall be the primary raceway serving the communications cabling. In general, each floor shall be equipped with cable tray, and the cable tray shall generally be routed in common areas (such as hallways) to facilitate access and maintenance. Cable trays shall be wire-basket type to minimize cost. Where cable tray is required to pass through smoke- and fire-rated barriers, the cable tray shall transition to fire-stopping pathway devices through the barrier and back to cable tray on the other side. Cable tray may penetrate nonrated barriers.
- 5.2. Fire alarm and other low-voltage systems running on proprietary cabling shall not be placed within this cable tray. Such systems shall have their own raceway/pathway, although in some cases it may be permissible to hang the cabling for these systems beneath the cable tray.
- 5.3. Conduit shall be used as a primary pathway in areas where ceiling is inaccessible.
- 5.4. Pathway in detention areas shall consist of conduit and be continuous from the device box to the detention controls equipment room. Pull boxes may be necessary in the pathway due to the length of the conduit run and/or number of bends in the conduit pathway.

#### 13050-6. J-Hook/Straps Pathway

- 6.1. J-hooks shall be used to provide non-primary pathway support for cables.

#### 13050-7. Sleeves

- 7.1. For multi-floor facilities, a minimum of 4 4-inch conduit sleeves shall connect the TR to the TR(s) above and/or below. For TRs with a higher concentration of cable, additional sleeves shall be required. The entrance facility (EF) shall be connected to the TRs either through sleeves or through raceway (if the EF is separate from the TR). For the EF, the quantity of sleeves and/or raceway is dependent upon the amount of backbone cabling leaving the EF.
- 7.2. A minimum of 1 2-inch conduit shall be provided for a cable path from a TR to the roof for services/equipment (e.g., antenna, etc.).

#### 13050-8. Fire-Stopping Pathway Devices

- 8.1. Fire-stopping pathway devices (e.g., EZ-Path, FlameStopper, etc.) are the preferred method for penetrating smoke or fire-rated structures. Penetrations

shall provide a code-compliant pathway for communications cabling through smoke- or fire-rated barriers. Cable pathway firestopping devices shall be provided in sufficient quantity so that the combined usable cross sectional area matches or exceeds the cross sectional area of the cable tray to be served.

**Figure 13050-2: Fire-Stopping Pathway Device**

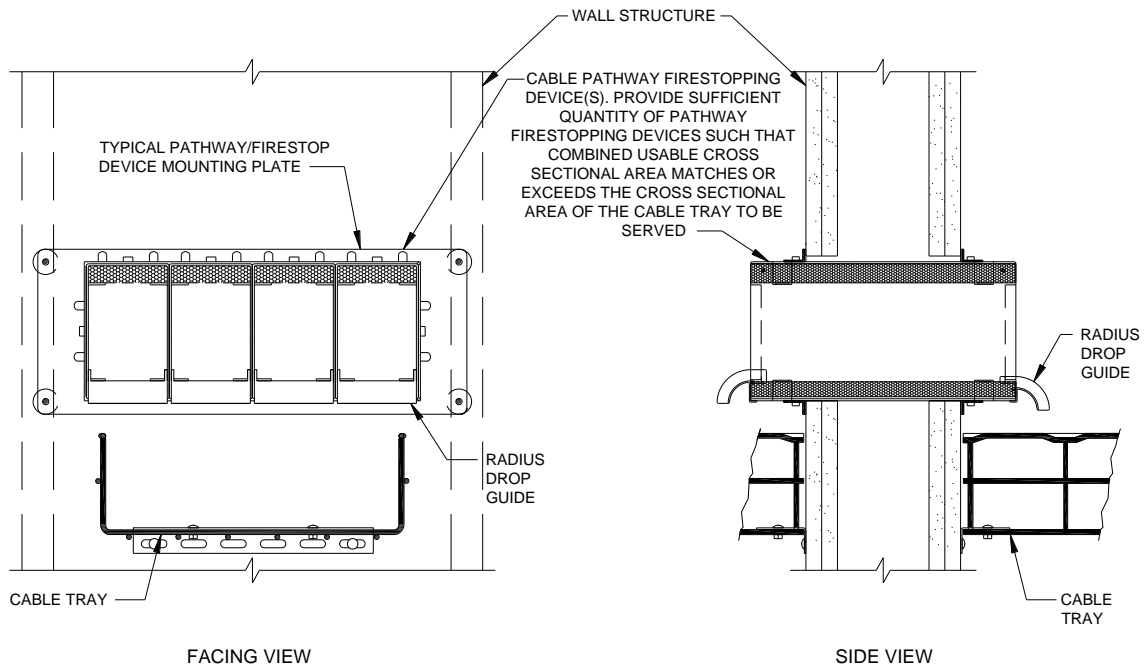

### 13050-9. Outside Plant Pathways

- 9.1. Outside plant (OSP) pathways are pathways that exist outside of a facility and are typically located underground. These pathways may consist of conduits and/or tunnels and typically enter a facility in the entrance facility (EF). There may also be telecommunications vaults required where conduit lengths exceed the maximum length allowed for a conduit run. Vaults also provide access to the duct bank for future additions. OSP conduit requirements will vary depending on the number of facilities and service provider requirements. Minimum requirements shall be 4 4-inch conduits from a given facility to the communications vault and 2 4-inch conduits from the communications vault to the location of the utilities (telephone, data, etc.) on the site. In areas where conduits may be subject to damage (due to dig-ups, shallow depth, placement below roads, etc.) the conduits shall be encased in concrete.

**13060-1. Telecommunications Grounding and Bonding System**

1.1. An industry-standard telecommunications grounding system shall connect all telecommunications spaces and the racks and raceway equipment within them to the building ground. The primary telecommunications room (TR) shall be equipped with a telecommunications main grounding busbar (TMGB), and the other TRs shall be equipped with telecommunications grounding busbars (TGBs). The busbars shall be interconnected with grounding wire, sized per BICSI's *Telecommunications Distribution Methods Manual*, and connected to the building ground.

**Figure 13060-1: Typical Grounding/Bonding Riser Diagram**

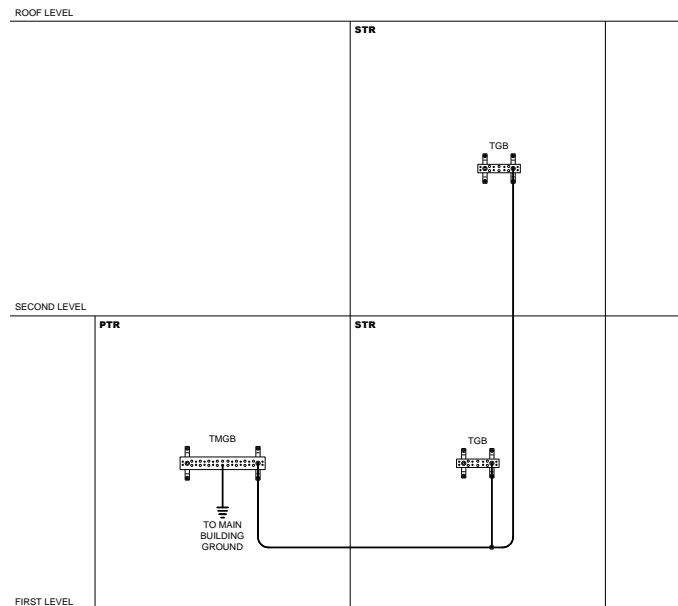

**Figure 13060-2: Typical Grounding Busbar**

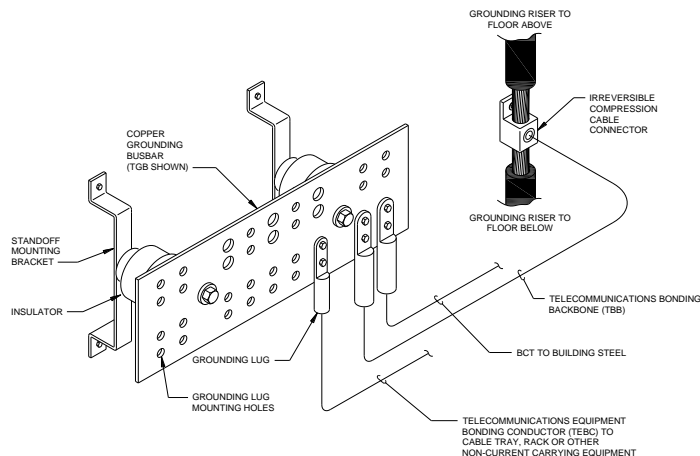

**13070-1. General**

- 1.1. The technology designer of record shall work with the owner to determine the best option(s) for voice, data, and cable television (CATV) connectivity for a given facility. Initial cost, ongoing cost, reliability, and speed shall all be considered. It is possible that multiple services may be provided by a single service provider.
- 1.2. The technology designer of record shall coordinate with the local service provider to ensure that any service provider requirements for power, ducts, spaces, etc., are addressed in the technology design.
- 1.3. The technology designer of record shall prepare and provide a report on the availability of communications at the project site, and an analysis of what will be required to provide communications to the site.
- 1.4. Refer to Chapter 5, "Civil," and Chapter 11, "Electrical," for additional information and requirements.

**13070-2. Cable Television (CATV)**

- 2.1. CATV, where available, shall be provided by a local service provider. The local service provider shall also be tasked with providing head-end equipment for modulating/demodulating and/or amplifying their signals as necessary within the facility.

**13070-3. Satellite Television**

- 3.1. Satellite television can be used in place of a local CATV service provider in the event that there is no local provider available or that there is some other requirement that can only be met through the use of satellite. The designer of record shall coordinate with the satellite company to ensure that the proper cable and equipment for distributing the satellite signal throughout the facility is provided to the owner.

**13070-4. Personal Communications Service (PCS)**

- 4.1. The technology designer of record shall coordinate with the BIA to determine if PCS, for cellular and pager coverage, shall be required within the facility. The PCS must be supported by an in-building wireless (IBW) system as discussed in section 13090. If PCS is requested, then the technology designer of record shall coordinate with the desired service providers to determine system specifications.

**13070-5. Data (Internet)**

- 5.1. The primary data requirement for outside connectivity is internet access, which is a mandatory requirement for all new facilities. Internet access can be provided by various means:

- 5.1.1. **Copper.** Copper service provides T1 type data service and is widely available. Multiple T1 circuits can be bonded together to provide greater bandwidth requirements as necessary.
- 5.1.2. **Fiber.** Fiber based data services provide bandwidth greater than copper services can provide (e.g. 10 Mbps or greater Ethernet). Fiber availability is not as common as fiber and is typically more costly.
- 5.1.3. **Satellite.** This is the least desirable option, but in some cases may be the only option available.

|                 |   |
|-----------------|---|
| Question/Issue: | Should an alternate network provider be provided?   |
| Recommendation: | We recommend an alternate network provider to support a secondary (redundant) connection for the E911 Call Center |
| Justification:  | To provide a backup connection in the event the primary service provider is disabled                              |

**13070-6. Voice (Dial Tone)**

- 6.1. Voice connectivity (dial tone) may be provided by a local service provider using copper or fiber services described above, but in some cases voice connectivity could be provided over the incoming data (Internet) service if VoIP is utilized.

**13070-7. Design**

- 7.1. The technology designer of record shall work with the owner to determine the requirements for these systems and then forward the information to the owner and the BIA for action, as required.



**13080-1. General****1.1. Data Network**

- 1.1.1. The data network shall be a complete, operable and scalable Internet Protocol (IP)-based wired network delivering seamless Ethernet connectivity throughout the building. Data network switches shall be Power over Ethernet (PoE) capable where necessary, in order to support wireless access points and Voice over Internet Protocol (VoIP) telephones, wireless networking equipment, and other equipment that utilizes PoE. The designer of record shall coordinate with the BIA to determine if IPv6 is required.
- 1.1.2. Hardware components shall be of the same manufacturer throughout the entire building. The data network shall fully integrate with the VoIP telephone system.

**1.2. Telephone System**

- 1.2.1. The telephone system shall be a VoIP digital system (it will make use of the communications cable system and the data network for communications). The technology designer of record shall work with the owner to determine the quantity of incoming lines for a specific site, based upon projected staff requirements. The capacity of stations/phones supported shall be sized to support the initial requirement plus future expansion. This system shall provide one main number for general incoming calls, with individual direct-dial numbers for each designated user.
- 1.2.2. Hardware components shall be of the same manufacturer throughout the entire building(s). The telephone/intercom system shall fully integrate with the data network system.

**1.3. Wireless Networking**

- 1.3.1. A wireless data network shall be installed in areas where this type of service is desirable, as determined by the BIA. In these areas of wireless service users shall be able to connect wirelessly to the network, authenticate, and establish encrypted sessions seamlessly. Wherever possible, wireless access points shall be placed in locations that are easy to access at all times.

The wireless network system shall be a system that fully integrates with the data network system and user authentication scheme. Wireless access points shall be capable of being configured and controlled through a single software administration interface.

**13090-1. General**

- 1.1. Low voltage systems include in-building wireless, intercom, public address and clock systems that are integral to the operation of these facilities. These systems are integrated with other systems found in Sections 13100 and 13110.

**13090-2. In-Building Wireless**

- 2.1. An in-building wireless system (IBW), also known as a distributed antenna system, uses cables, amplifiers, and antennas to distribute wireless signals throughout a facility. An IBW also ensures that specific signals from outside the facility are redistributed inside the facility in order to provide coverage throughout, and vice versa.
- 2.2. The IBW can be used for public safety / first responder, facility 2-way radio, personal communications service (PCS), for cellular phone services from multiple operators, and wireless pager systems. Such systems are also being used in very large facilities to facilitate wireless data networking, location tracking and radio frequency identification (RFID). Industry specific frequencies can also be transmitted on an IBW.
- 2.3. Depending upon the AHJ, this system may be required to assure that public safety / first response radio systems will work throughout the building (including the basement if applicable). Secondly, these systems may also be used to enhance the reliability/use of cell phones throughout the facility, regardless of building construction and glazing materials.
- 2.4. The technology designer of record shall coordinate with BIA and AHJ to determine if IBW is required and which functions the system shall provide. Additional service provider coordination may be required by the technology designer of record if PCS is requested.

**13090-3. Intercom****3.1. Facility**

|                 |   |
|-----------------|---|
| Question/Issue: | Shall the VoIP telephone system fulfill general facility intercom requirements?   |
| Recommendation: | We recommend provisioning intercom functions as an extension of the VoIP telephone system rather than point-to-point intercom stations (e.g. after hour use at front door, loading dock during and after business hours). |
| Justification:  | The VoIP telephone system is programmable which will enable more control, and is adaptable to changes. Dedicated intercom stations appear as telephone sets to the telephone system.                                      |

- 3.1.1. **General Requirements.** Inter-communication, or intercom, is a separate system that shall use the VoIP telephone system as the backbone. Input to the intercom system shall be through the telephone or an integrated ancillary device.
- 3.1.2. **Specific Requirements.** In addition to the intercom functions provided by telephone units, tamper-resistant intercom stations should be located at loading docks and public accessible, after-hours doorways. These units shall call to a 24-hour staffed location. Should the intercom call go unanswered, the telephone system dial plan will forward the call to alternate locations. The technology designer of record shall identify the location of these ancillary devices and specify equipment and installation requirements.

3.2. **Visitation**

|                 |  |
|-----------------|--|
| Question/Issue: | What provisions, if any, should be made to facilitate recording of Visitation Intercom systems to support authorized recording?<br><br>Are there real-time, live, monitoring requirements?                       |
| Recommendation: | We recommend wiring the phones back to a secured central location (detention control equipment room or telecommunications room) where the lines can be recorded by the proper authorities should the need arise. |
| Justification:  | Capability is available and ready, avoidance of additional construction later.   |

- 3.2.1. **General Requirements.** Provide communication between detainees and the public through the use of either a handset to handset or handset to speaker device.
- 3.2.2. **Specific Requirements.** Vandal resistant, detention grade handsets and hands-free speaker device. Hearing-aid compatible.

**13090-4. Public Address**

|                 |   |
|-----------------|---|
| Question/Issue: | Shall the telephone system be used to initiate Public Address / overhead paging announcements or fixed location microphone  |
| Recommendation: | We recommend using the telephone system to restrict authorized telephone sets to conduct public address announcements.  |
| Justification:  | The telephone system is easily configurable to permit and restrict paging capabilities for each telephone set - and is more flexible than fixed location microphones. |

**4.1. General Requirements.** The public address (PA) system is a separate system that shall use the VoIP telephone system as the backbone. The primary function of the PA is to broadcast verbal messages originating from an authorized standard phone handset. Messages shall be broadcasted to any specific loudspeaker zone or to all loudspeaker zones. PA appurtenance requirements include a system processor, a zone selection module, a tone generator and self-amplified speakers as required. Head-end equipment for the PA system shall reside within the TR and shall require an equipment rack, a 3 feet by 3 feet section of wall space, a 120-volt AC circuit, and cable pathway from the TR or SR to each device within the facility.

**4.2. Specific Requirements**

**4.2.1.** The technology designer of record shall identify the location of the PA appurtenances and specify equipment and installation requirements. Following are the performance requirements for a PA system within the administration and law enforcement areas:

- Zoned audio distribution
- Intelligibility Index (STI) of .80 or better
- Sound Pressure Level (SPL) of 10.0 dB above ambient noise floor, +/- 2.00 dB.
- UPS power available during power outages

**4.2.2.** The PA system performance requirements within the detention area are as follows:

- Zoned audio distribution
- Intelligibility Index (STI) of .80 or better
- Sound Pressure Level (SPL) of 15.0 dB above ambient noise floor, +/- 2.00 dB.
- UPS power available during power outages.

- 4.3. **Integration with other Systems.** This system shall interface with the fire alarm/life safety system and shall mute during an event.

**13090-5. Clocks**

- 5.1. Synchronized Clocks are used to sequence events within a facility. These systems use a synchronization pulse from federal government national atomic clock research facilities via the internet or RF broadcasts.
- 5.2. **General Requirements.** The clock system shall be capable of receiving global positioning system (GPS) time signals for synchronization. The system shall be wireless and continually synchronizing clocks throughout the facility.
- 5.3. **Specific Requirements**
- 1.1.1. Clocks shall automatically adjust for Daylight Saving Time (even after power outages), eliminating maintenance.
- 1.1.2. Clocks in the detention area must be robust against damage or removal. In spaces of medium to high security clocks should be located outside of reach from the incarcerated population. In these spaces the clocks should be located in areas where they are visible through a clear polycarbonate material (glass) such as in a secure guard station.

**13100-1. General**

- 1.1. Security systems are comprised of technologies designed to control, monitor, record, alarm and/or notify authorities when a particular event(s) has taken place. These technologies include various hardware devices, computers, software, and the environments within which the devices work. Security systems shall typically be provided in administration, law enforcement, courts, and detention areas, along with the perimeter of each site.
- 1.2. Typical facility security systems include access control, video surveillance, and intrusion detection.
- 1.3. Staff duress systems are located where interaction with the public may escalate into an emergency or crisis situation. A push-button can be activated which notifies and dispatches additional personnel to intervene.
- 1.4. Detention systems include door controls (cell, movement control, interlocks), door monitoring, intercoms (cell, room, movement control), paging (cell, room), detainee duress (audio detection, pushbutton), video surveillance (cell, room, movement control) and perimeter detection.
- 1.5. Security systems shall be monitored by a security management system (SMS) that resides in a 24-hour staffed location. Security systems may interface with other building systems.
- 1.6. Metal detection and X-ray scanner systems are typically purchased by the BIA as part of facility equipment and operate as stand-alone devices. They are often sizable and shall be considered when planning space in rooms or circulation where they will be located.
- 1.7. Refer to Section 13110 for information about interview room requirements and controls.

**13100-2. Access Control System**

**QUESTION:** Should a badge station (workstation, badge printer, camera, lighting and photo backdrop) be incorporated into access control scope?

**RECOMMENDATION:** We recommend including photo ID badges as part of Personal Identification Verification (i.e., smart card, proximity, or magnetic stripe reader) as opposed to issuing card access badges without photographic identification. The photographic requirements do not apply to access control fobs, the same badging station can still be used to assign fobs.

**JUSTIFICATION:** Provides identification on the access cards to prevent the misuse of access privileges.

- 2.1. An access control system (ACS) (also known as a door control system) controls and monitors select doors throughout a facility. It provides real-time monitoring of entryways, stores entry activity for future retrieval (such as who entered a particular doorway at a given time), and secures or opens doors based upon different variables (such as the time of day, departmental access verification, or individual access verification).
  - 2.1.1. The ACS is comprised of personal identification verification (PIV) devices connected to ACS control panels.
  - 2.1.2. ACS control panels shall communicate with an application server where the centralized database, ACS control application, credentials, authorization privileges, and event logging are administered and stored.
    - 2.1.2.1. The ACS application server shall include a historical log of portal activity (e.g., who entered which door and when).
    - 2.1.2.2. The ACS application server shall provide real-time monitoring of portals.
    - 2.1.2.3. Administration of the ACS application and credential / authorization database shall be restricted to authorized personnel.
  - 2.1.3. PIV devices shall be card readers, card readers with keypads, or biometric devices. PIV devices shall be connected to the ACS to verify credential(s) and authorize operation of controlled device(s) (e.g., locksets, etc.). Keypad operation shall only be used in conjunction with card reader operation (two factor authentication).
  - 2.1.4. ACS control panels shall be located in secured telecommunications rooms (TR), server rooms (SR), data centers (DC), or detention control equipment rooms.
  - 2.1.5. The ACS application server shall be located in a secured TR, SR or DC.
- 2.2. **General Requirements.** The ACS shall require a minimum of 4 feet wide by 8 feet high of wall space within the TR, a dedicated 120 VAC 20A generator circuit, and cable pathway from the TRs to device locations.
  - 2.2.1. Doors which are controlled or monitored shall be equipped with the following:
    - Controlled entryways shall have electronic locking systems, PIV devices, and door position switches, and shall provide free egress from the facility or room at all times. The ACS shall maintain a secure door at all times outside of scheduled building operation or authorized entry of personnel.
    - Monitored entryways shall have door position switches that indicate when a door has been opened or has been held open for too long.
    - Raceway for controlled or monitored doors shall be necessary. See Figure 13100-1 for an example of raceway requirements for a double door with crash bars. Single doors, and/or doors with different types of

door hardware and PIVs (readers), may require different raceway and ancillary devices. Furthermore, different ACS manufacturers may require different raceway.

**Figure 13100-1: Typical Raceway for a Controlled Door**

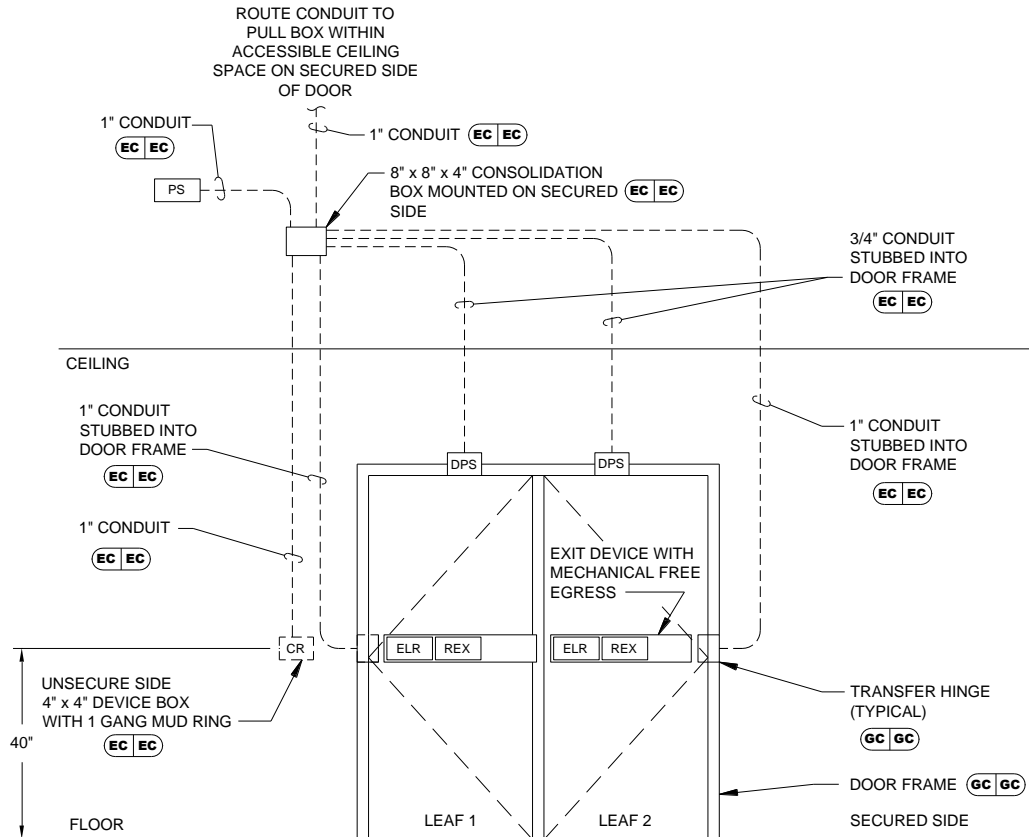

ABBREVIATIONS:

|     |                           |
|-----|---------------------------|
| CR  | CARD READER               |
| DPS | DOOR POSITION SWITCH      |
| EC  | ELECTRICAL CONTRACTOR     |
| ELR | ELECTRIC LATCH RETRACTION |
| GC  | GENERAL CONTRACTOR        |
| PS  | POWER SUPPLY              |
| REX | REQUEST TO EXIT SWITCH    |

**2.3. Specific Requirements.** The technology designer of record shall work with the BIA to determine locations where access control, either controlled or monitored, shall be provided. The following are some locations that shall be considered:

- **Administration.** Consider and evaluate requirements for building entrances, employee only entrances from public areas, parking lot controls, impound lots, fence lines, fitness rooms, training rooms, women's lockers, men's lockers, sleep rooms, secured records, evidence and property storage areas, TRs, SRs, DCs, communications rooms (dispatch), radio rooms, radio towers, and computer training rooms.



- **Courts.** Consider and evaluate requirements for building entrances, employee-only entrances from public areas, conference rooms, courtrooms, chambers, secured records, TRs, SRs, and DCs.
- **Law Enforcement.** Consider and evaluate requirements for building entrances, employee-only entrances from public areas, secured records, evidence and property storage areas, firearm and equipment rooms, ammunition storage rooms, TRs, SRs, DCs, and computer training rooms.
- **Detention.** Consider and evaluate requirements for building entrances, employee-only entrances from public areas, TRs, and detention control and detention controls equipment rooms. Note that door hardware where ACS devices are placed may have detention-grade hardware (high voltage relay may be required for ACS device); however, detention doors are to be controlled by the detention control system, not by the ACS.

**2.4. Integration with other Systems.** The ACS shall be an integral part of, or shall interface with the video surveillance system, intrusion detection system, duress system, and/or building automation system.

Monitoring of doors, event logs, and card holder activity, as well as control of doors and gates shall be a part of a SMS located in a 24-hour staffed location.

### 13100-3. Video Surveillance System

QUESTION: How many days of storage of are required for recorded video?

RECOMMENDATION: We recommend a network recorder with capacity for 30-45 days video retention

JUSTIFICATION: This provides an activity history to record the typical coming and going of people at all camera locations. The duration allows authorities adequate investigation time after an incident.

- 3.1.** The primary function of a video surveillance system (VSS) is to monitor and/or record events at specified locations throughout the facility. Cameras shall be vandal proof, and be either fixed or equipped with pan-tilt-zoom (PTZ) capability, depending upon the application.
- 3.2. General Requirements.** The VSS shall be Internet protocol (IP) based, and shall use the cabling system and data network specified in Sections 13040 and 13080 for the transmission of all data and video signals. Power over Ethernet (PoE) shall be used to eliminate the need for separate power for fixed cameras (additional power may be required for PTZ cameras, as well as for environmental housings for cameras in exterior locations and sallyports).

The VSS shall be capable of providing secured viewing of both live output and recorded footage from all cameras using a standard web browser and digital viewing software, from locations within the local facility and from remote locations over the internet (subject to user verification/security). The VSS shall

be monitored for system failures, and shall be capable of providing monitoring and playback from the SMS located in a 24-hour staffed location. The designer of record shall coordinate with the BIA to ascertain whether recording and remote viewing will be enabled upon initial installation.

The VSS shall require rack and /or wall spaces within a TR, a 120-volt AC circuit, and cable pathway from the TRs to device locations. Video storage shall be located in the secured TR, SR or DC. Minimum camera resolution shall be VGA / 4CIF / D1 at 24 images per second.

- 3.3. Specific Requirements.** The technology designer of record shall work with the BIA to determine locations where video surveillance and monitoring shall be provided. The following are some locations that shall be considered:
- ***Administration.*** Consider and evaluate requirements for building entrances, employee-only entrances from public areas, parking lot controls, impound lots, fence lines, secured records, evidence and property storage areas, TRs, SRs, DCs, radio rooms, and radio towers.
  - ***Courts.*** Consider and evaluate requirements for building entrances, employee-only entrances from public areas, secured records, TRs, SRs, and DCs.
  - ***Law Enforcement.*** Consider and evaluate requirements for building entrances, employee-only entrances from public areas, secured records, evidence and property storage areas, firearms and equipment rooms, ammunition storage rooms, TRs, SRs, and DCs.
  - ***Detention.*** Consider and evaluate requirements for building entrances, employee-only entrances from public areas, detention controls equipment rooms, movement control doors, booking areas, visitation waiting rooms, video arraignment rooms, dayrooms, dorm rooms, safety cells, and holding areas. Consider and evaluate requirements for monitors in detention control rooms.
- 3.4. Integration with other Systems.** The VSS shall be an integral part of, or shall interface with the ACS, IDS, and duress system.

#### **13100-4. Intrusion Detection System**

- 4.1.** An intrusion detection system (IDS) is used to detect unauthorized entry into protected spaces.
- 4.2. General Requirements.** An IDS typically incorporates contact, motion, and/or glass-break sensing devices. Perimeter fence detection can be provided by fence, underground, and/or above-ground sensors.

The IDS shall require a minimum of 4 feet by 8 feet of wall space within a TR, a dedicated 120 VAC 20A generator circuit, and cable pathway from the TRs to device locations.

- 4.3. **Specific Requirements.** The technology designer of record shall work with the BIA to determine locations where intrusion detection sensors and monitoring shall be provided. The following are some locations that may be considered:
- **Administration.** Consider and evaluate requirements for building entrances, employee-only entrances from public areas, parking lot controls, impound lots, fence lines, secured records, evidence and property storage areas, TRs, SRs, DCs, radio rooms, and radio towers; consider and evaluate requirements for monitoring of the IDS as part of SMS in a 24-hour staffed location.
  - **Courts.** Consider and evaluate requirements for building entrances, employee-only entrances from public areas, secured records, TRs, SRs, and DCs.
  - **Law Enforcement.** Consider and evaluate requirements for building entrances, employee-only entrances from public areas, secured records, evidence and property storage areas, firearms and equipment rooms, ammunition storage rooms, TRs, SRs, and DCs; consider and evaluate requirements for monitoring of the IDS as part of SMS in a 24-hour staffed location.
  - **Detention.** Consider and evaluate requirements for intrusion detection in/at building entrances, employee only entrances from public areas, detention control room, and the perimeter; consider and evaluate requirements for monitoring of the IDS in the detention control room.
- 4.4. **Integration with other Systems.** The IDS shall be an integral part of, or shall interface with the ACS and VSS.

13100-5. Staff Duress System

|  |
|--|
| QUESTION: Should portable (hand held or belt clip) staff duress devices be anticipated?  |
| RECOMMENDATION: Portable duress devices, that are compatible with the staff duress system, should be contemplated during the design process. |
| JUSTIFICATION: Allows for a portable extension of the duress system and provides redundancy for the fixed system.                            |

- 5.1. The staff duress system shall be used in locations where interaction with the public may escalate into an emergency or crisis situation. Hardwired duress buttons may be used in fixed locations; portable personnel duress devices may be used to augment or replace fixed location duress buttons.
- 5.2. **General Requirements.** The duress system shall require a minimum of 4 feet wide by 8 feet high of wall space within a TR, a dedicated 120 VAC 20A generator circuit, and cable pathway from the TRs to device locations (fixed duress buttons and portable duress sensors).

- 5.3. **Specific Requirements.** The technology designer of record shall work with the BIA to determine locations where duress system device and monitoring shall be provided. The following are some locations that may be considered:
- ***Administration.*** Consider and evaluate requirements for fixed duress buttons at reception desks, clerk desks, and interview rooms. Duress systems shall be incorporated into the SMS as well as reported and monitored in a 24-hour staffed location for directing the response to a duress call.
  - ***Courts.*** Consider and evaluate requirements for fixed duress buttons at clerk, recorder and bailiff desks, the judicial bench, and probation locations. Consider and evaluate requirements for portable duress devices for bailiff staff.
  - ***Law Enforcement.*** Consider and evaluate requirements for fixed duress buttons at the reception desk and interview rooms. Consider and evaluate requirements for monitors in a 24-hour staffed location as part of the SMS.
  - ***Detention.*** Refer to Section 13100-6 for specifications for the detainee duress system.
- 5.4. **Integration with other Systems.** The duress system shall be an integral part of, or shall interface with the ACS and VSS.

Monitoring of duress alarms shall be provided within a 24-hour staffed location.

#### **13100-6. Detention Systems**

- 6.1. Detention systems may include door controls, door monitoring, intercoms, paging (cell, room), detainee duress (audio detection, pushbutton), video surveillance (cell, room, movement control) and perimeter detection.
- 6.2. **General Requirements**
- 6.2.1. A secured room shall be required for the detention control room. An additional secured room, the detention controls equipment room, shall be required to house the detention systems equipment. Both rooms shall be located in the detention facility, in close proximity to each other. Access to the detention controls equipment room shall be controlled from the detention control room.
- 6.2.2. Unless noted otherwise, detention systems and controls shall be separate from facility security systems. The technology designer of record shall work with the BIA to determine the applicability of the systems, and the extent to which they can be integrated with facility security systems, without compromising the safety and security of the facility.
- 6.2.2.1. TR functions shall not be combined with the detention controls equipment room unless the same staff is responsible for maintaining both the telecommunications and detention control systems.

- 6.2.2.2. The detention controls equipment room shall utilize multiple, dedicated 120 VAC 20A UPS and generator powered circuits, and cable pathway (conduit) to device locations.
- 6.2.3. **Operator Stations.** A minimum of 2 detention control operator stations shall be provided in the detention control room. Operator stations shall be touch screens. Displays and controls shall graphically represent the detention facility. The technology designer of record shall confirm whether additional or alternate monitoring locations are required.
- 6.2.4. **Detention Door Controls.** The detention door control system shall control doors in detention areas, including but not limited to, cell doors, movement control doors, and sallyport interlocks.

QUESTION: What type of door control system is required?

RECOMMENDATION: We recommend using a solid state programmable door control system with a minimum of 2 touch screens rather than a hard-wired relay and switch-based control panel system.

JUSTIFICATION: This enables quick replacement of operator controls (touch screen monitor) and the control system is software based rather than hardware permitting rapid adaptation to changing requirements.

The detention door control system shall be software configurable and solid-state. Door status and controls shall be displayed graphically at the detention operator stations.

The detention door control system shall be designed to fail in such a manner as to leave the doors secured as approved by the BIA (fail secure).

Door status (secured, unsecured) shall be determined by the combination of door position switch and latch bolt switch. Partial system failures of monitored doors shall be reported as unsecure.

- 6.2.5. **Detention Door Monitoring.** The door monitoring system shall monitor for unauthorized operation and/or unsecured status due to malfunction, manual operation (use of keys), and security breaches.
- 6.2.6. **Detention Intercom.** The detention intercom system shall provide bi-directional, audible communications between the detention control room and specific locations throughout the detention facility.
  - 6.2.6.1. The intercom system shall be controlled from the detention control room operator stations. The detention control room shall have a separate microphone and speaker(s) with level controls for each operator station. Each detention control operator station shall have simultaneous and independent intercom capabilities.

- 6.2.6.2. The intercom system shall incorporate passive and active noise cancelling technology to improve intelligibility. The intercom system shall be microprocessor controlled, software configurable, and shall consist of vandal resistant, detention-grade equipment.
- 6.2.6.3. Audio levels (transmit and receive) for remote intercom stations shall be individually configurable and configurations stored.
- 6.2.6.4. General Detention Intercom. The general detention intercom system shall be implemented in locations where detainees may be located or transiting (e.g., holding rooms, safety rooms, dormitories), and specifically excludes movement control intercom and non-detention areas served by facility telephones with intercom functionality.
- 6.2.6.5. Movement Control. The movement control intercom system shall be used to coordinate the movement of staff and detainees. These intercom stations shall be associated with remote controlled detention doors (e.g., sallyports and booking, holding, and detention rooms) within the detention area.
- 6.2.7. *Detention Paging*. The detention paging system shall allow announcements to be made from the detention control room to detention controlled spaces. The paging system shall consist of vandal resistant, detention-grade equipment.
- 6.2.8. *Detainee Duress*. The detainee duress system shall provide a means for detainees to request assistance from the detention control room officer. The technology designer of record shall work with the BIA to determine if the general detention intercom is adequate or if audio detection shall be required in addition to the detention intercom system. Components located in detainee occupied areas shall be vandal resistant and detention-grade.
- 6.2.9. *Detention Video Surveillance*. The technology designer of record shall work with the BIA to determine surveillance, monitoring and recording requirements.
  - 6.2.9.1. Consideration shall be given to monitoring movement control doors and all areas that are not directly visible from the detention control room. Video surveillance associated with movement control shall have cameras located on each side of the controlled door with views that can identify the staff and/or detainee, as well as ascertain the situation (security risk) prior to operating the detention door.
  - 6.2.9.2. Consideration shall be given to quantity, size, and multiple camera capability of monitors located in the detention control room. Camera housings shall be vandal resistant and detention-grade, and exterior camera housings shall have suitable environmental controls.
  - 6.2.9.3. Refer to Section 13100-3 for additional VSS standards.

**6.2.10. Detention Perimeter Detection.** The detention perimeter detection system shall be designed such that the detention control room officer is notified of unscheduled perimeter intrusions or exits. In addition to perimeter doors, fence detection sensors and intrusion detection detectors shall monitor the detention facility's perimeter as determined by the technology designer of record working with the BIA.

**6.3. Integration with other Systems.** The detention control room operator stations shall integrate the operation of the following systems: detention door control, detention intercom, detention paging, detainee duress, detention staff duress, detention video surveillance, and perimeter detection systems.

The detention system shall interface with the facility ACS, VSS, IDS, duress system, PA system, intercom system, fire alarm system, and/or the building automation systems as required by the BIA.

**6.3.1.** Monitoring of doors, door activity, cameras, duress devices, event logs and perimeter detection shall be provided within the SMS.

**6.3.2. Detention Door Controls.** The detention door control system shall be coordinated with the movement control, detention intercom, and detention video surveillance systems to enforce the detention facility's door control policies.

**6.3.3. Detention Door Monitoring.** Detention door monitoring is a function of the detention door control system, utilizing the same monitor inputs as the detention door control system. Detention door monitoring alarms shall be reported at the detention door control operator stations and the SMS.

**6.3.4. Detention Intercom**

**6.3.4.1.** General Detention Intercom. The general detention intercom system shall be integrated with the detention control operator stations.

Each operator station shall operate independently of others, but only 1 operator station at time can control a particular intercom.

The technology designer of record shall work with the BIA to determine if the detention intercom system shall be either an extension of the facility intercom system or a separate system.

Detention detainee duress utilizing audio detection may be integrated with the intercom system. Intercom stations in holding and safety rooms may be used as audio sensors.

**6.3.4.2.** Movement Control. The movement control intercom system shall be integrated with the detention control operator stations. When use of the movement control intercom is initiated, the detention door control panel and detention video surveillance system associated with the intercom location shall be activated.

Each operator station shall operate independently of each other and only 1 operator station at time can control a particular door.

**6.3.5. Detention Paging.** The detention paging system shall be integrated with the detention operator stations and detention intercom systems. The technology designer of record shall work with the BIA to determine whether the detention paging system shall be a discrete system, or an extension of the facility PA (or paging) system.

**6.3.6. Detainee Duress.** Refer to intercom requirements in this section for detainee duress integration considerations.

**6.3.7. Detention Video Surveillance.** The detention video surveillance system shall be viewable at the detention control room as well as at the SMS. Cameras and monitors shall switch as required to monitor all areas. Cameras and monitors shall switch, as required, for manual selection and intercom selection at the detention operator stations.

The technology designer of record shall work with the BIA to determine if the detention surveillance, monitoring and recording requirements should be an extension of the facility VSS.

**6.3.8. Detention Perimeter Detection.** The perimeter detection system shall report system status and alarms to the detention control operator stations and be integrated and monitored by the SMS.

#### **13100-7. Security Management System (SMS)**

**7.1.** The SMS integrates the monitoring of the various security systems. The SMS operator interface (displays and consoles) shall reside in a 24-hour staffed location. The monitoring location may be the watch commander's office depending on the facility requirements. The designer of record shall work with BIA to determine if alternate or additional monitoring locations are desired.

**7.2. General Requirements.** The SMS system shall require display and console space in the designated 24-hour staffed location. The head-end equipment shall require space in a server cabinet and/or network rack, or a minimum of 4 feet wide by 8 feet high of wall space within the TR, SR or DC. The SMS shall have a UPS power source from a dedicated 120 VAC 20A generator circuit. Cable pathways shall be provided between the monitored systems and the device locations.

**7.3. Specific Requirements.** The technology designer of record shall work with the BIA to determine locations for SMS monitoring and verify which systems shall be integrated and monitored.

**7.4. Integration with other Systems.** Systems and functions to be monitored shall include the ACS, VSS, IDS, duress system(s) and the detention systems.

#### **13100-8. Metal Detection Systems**

**8.1.** Metal detectors for screening the public and detainees may be fixed, portable portal based, or portable battery operated hand wands.

**8.2. General Requirements.** Fixed portal based metal detectors shall require dedicated 120 VAC 20A circuit.



**8.3. Specific Requirements.** The technology designer of record shall work with the BIA to carefully determine the requirements for metal detectors to match anticipated threat levels. The following are some locations that may be considered:

- ***Courts.*** Consider and evaluate requirements for metal detectors to screen the public prior to entering courts and/or offices.
- ***Law Enforcement.*** Consider and evaluate requirements for metal detectors to screen individuals entering the interview rooms and detainees in the booking area.
- ***Detention.*** Consider and evaluate requirements for metal detectors to screen the public prior to entering the detention facility.

#### **13100-9. X-ray Scanner Systems**

**9.1.** X-ray scanners are used to screen for weapons and contraband to prevent the entry of these objects into the facility. Scanners shall be located at public entrances, especially prior to entering courtrooms or detention facilities, and at shipping facilities to scan received mail and packages.

**9.2. General Requirements.** Fixed locations shall require dedicated circuits. Small units shall require 120 VAC 20A circuit and larger units may require 208 VAC single or 3 phase circuits. Consideration shall be given to providing UPS power to protect the x-ray scanner(s).

#### **9.3. Specific Requirements**

The technology designer of record shall work with the BIA to determine locations where x-ray scanners shall be provided. Scanners shall be capable of color and reverse black and white display of organic and inorganic materials, with high/low density striping. Consideration shall be given to the anticipated threats and the size of the objects to be scanned – mail, small parcel, checkpoint, large parcel, and small cargo. The following are some locations that may be considered.

- ***Administration.*** Consider and evaluate requirements for scanners at building entrances, the mail room, and at the loading dock (shipping and receiving areas).
- ***Courts.*** Consider and evaluate requirements for scanners at public building entrances.
- ***Law Enforcement.*** Consider and evaluate requirements for scanners at public building entrances.
- ***Detention.*** Consider and evaluate requirements for scanners at public building entrances.

**13110-1. Room Technology Systems**

- 1.1. Room technologies can include such systems as audio and video recording, playback, and distribution, sound reinforcement, low voltage control, remote video arraignment (and expert testimony), and interview rooms and controls.

**13110-2. Audio**

- 2.1. Audio systems can distribute and record audio from various signal sources such as microphones, computers, compact discs (CD), digital versatile disc (DVD), Blu-ray high-definition (HD) discs, video home system (VHS) cassette, MP3/iPod and other signal sources.

**2.2. Sound Reinforcement****2.2.1. *General Requirements***

- 2.2.1.1. The sound reinforcement system requires an equipment mounting location and 120-volt AC circuit, both located within the room served, as well as cable pathway to device locations within the room.
- 2.2.1.2. Unless otherwise specified by the BIA, all rooms with a permanently installed video projection system shall also be equipped with sound reinforcement.
- 2.2.1.3. Volume control for sound reinforcement systems shall be accomplished via the low voltage control system defined in Section 13110-4. The control and sound reinforcement systems shall be configured so that the fire alarm/ life safety system mutes audio during an event.

**2.2.2. *Specific Requirements***

- 2.2.2.1. Courtroom. A sound reinforcement system is used to distribute a presenter's spoken words to an audience area, and/or to provide sound distribution for a presentation or video. Performance requirements for courtroom sound reinforcement systems are as follows:

- Intelligibility index (STI) of 0.85 or better
- Loudspeaker frequency response range of 100 Hz – 20.0 kHz, +/- 2.00 dB
- Sound pressure level of 85.0 dB +/- 2.00 dB
- Courtroom sound reinforcement systems shall be capable of providing signals to the assisted listening system (ALS).

**2.2.2.2.** Conference Room. A sound reinforcement system is used to distribute audio for tele/videoconferencing, CD/DVD media content playback, as well as to convey spoken words during presentations via wired and wireless microphone systems. Performance requirements for conference room sound reinforcement systems are as follows:

- Loudspeaker frequency response range of 75.0 Hz – 20.0 kHz, +/- 2.00 dB
- Sound pressure level of 90.0 dB +/- 2.00 dB
- Wireless microphone frequency spectrum of 554 – 698 MHz
- Conference room sound reinforcement systems may provide signals to the assisted listening system (ALS).

**2.2.2.3.** Training Room. A sound reinforcement system is used to distribute an instructor's spoken words via wired and wireless microphone systems, as well as CD/DVD media content playback. Performance requirements for training room sound reinforcement systems are as follows:

- Loudspeaker frequency response range of 75.0 Hz – 20.0 kHz, +/- 2.00 dBC
- Sound Pressure Level: 90.0 dB +/- 2.00 dBC
- Wireless microphone frequency spectrum of 554 – 698 MHz
- Training room sound reinforcement systems may provide signals to the assisted listening system (ALS).

If the training room is anticipated to serve as an emergency operations center, the following additional requirements shall apply:

- In a multiple video image scenario, provide the capability of selecting audio content other than the standard "audio follow video" switching.
- Tele/videoconferencing audio signal shall be encrypted.

### **2.3. Signal Sources**

**2.3.1. *General Requirements.*** Various signals sources may provide input into the audio system. The systems shall be able to utilize both stereo and monophonic types. Dolby Surround signals (i.e., 5.1, 7.1, 7.2, and 7.4) shall not be considered as viable signal types in this environment.

**2.3.2. *Specific Requirements.*** Audio signal source voltage levels shall adhere to professional output levels (line level), and “balanced” signal topology shall be used wherever possible. System performance requirements are as follows:

- Line level of 1.737 volts peak to peak (Vpp), +/- 10.0%, or +4.00 dBu
- Consumer Levels of 0.447 Vpp, +/- 10.0%, or -10.0 dBV
- Input impedance of 10.0 kΩ or greater
- Output Impedance of 100 Ω or less
- Total harmonic distortion (THD) of 1.00 %, +/- 10.0%

**2.3.3. *Integration with other Systems.*** The local low voltage control system shall be able to functionally operate any rack mounted signal source via two-way RS-232 serial data stream, infrared, relay contact closure, or musical instrument digital interface (MIDI) control protocol.

#### **2.4. Side Bar Conversation Noise-Masking**

**2.4.1. *General Requirements.*** Noise-masking systems shall provide audible privacy during side-bar conversations, such that the jury and audience are unable to comprehend discussions between the judge and the attorneys.

**2.4.2. *Specific Requirements.*** The system shall be zoned, “pink” noise audio and distributed through the ceiling loudspeakers of the sound reinforcement system.

**2.4.3. *Integration with other Systems.*** Noise-masking shall be activated by the low voltage control system, which shall engage a preset function within the sound reinforcement system’s digital signal processor (DSP).

#### **2.5. Recording**

**2.5.1. *General Requirements.*** The audio system shall have the ability to record and play back all verbal testimony, orders, and directions for the judge, clerk and law enforcement officers.

##### **2.5.2. *Specific Requirements***

**2.5.2.1.** The recording medium may be a computer server, CD-ROM or cassette, based upon the current technological preference of the BIA. Foot pedal activation of playback functions shall allow secretarial transcription. Signals shall be recorded to the storage medium in real time and include a time stamp indicating the date and time (hour and minute) that the event is recorded.

**2.5.2.2.** Microphones shall be professional quality dynamic or condenser type, providing “balanced” signal output.

**2.5.3. Integration with other Systems.** The recording system shall be fully integrated into the sound reinforcement system so that it can record side-bar conversations while the pink noise sound source is activated. The recording system shall also play back through the existing ceiling loudspeakers. All operational functions shall be accomplished via the low voltage control system.

**2.6. Assisted Listening System (ALS)**

**2.6.1. General Requirements.** The ALS shall provide enhancement of all voice and program audio for the hard of hearing, in accordance with the American Disabilities Act. The ALS shall also provide a secondary translation channel of audio when required.

**2.6.2. Specific Requirements.** The ALS shall include infrared transmission and personal belt pack reception units, with an ear-bud and rechargeable batteries.

**2.6.3. Integration with other Systems.** Audio signals shall be provided by the sound reinforcement system’s DSP unit. Power up/down shall be accomplished via the low voltage control system.

**2.7. Language Translation**

|                 |   |
|-----------------|---|
| Question/Issue: | Does the BIA want to integrate the language translation system with the assisted listening system?                |
| Recommendation: | Include language translation as part of ALS   |
| Justification:  | Court proceeding participants and observers may be non-English speaking, thus necessitating translation services. |

**2.7.1. General Requirements.** The language translation system shall provide personal voice language translation during court proceedings.

**2.7.2. Specific Requirements.** The language translation system shall be a sub-system of the ALS, and shall use infrared transmission and reception, along with personal receivers that use rechargeable batteries.

**2.7.3. Integration with other Systems.** Audio signals shall be provided by the sound reinforcement system’s DSP unit. Power up/down shall be accomplished via the low voltage control system.

**13110-3. Video**

**3.1.** Video systems shall distribute, display, and record video signals from such sources as computers, video annotation devices, media players (e.g., DVD, Blu-ray, and VHS), and cameras (e.g., fixed, pan/tilt/zoom (PTZ), and document cameras).

### 3.2. Distribution

- 3.2.1. *General Requirements.*** The video system shall have the ability to distribute signals from a single video source to 1 or more display units. The system shall also be able to scale lower resolution signal types to the resolution of the display.

|                 |  |
|-----------------|--|
| Question/Issue: | Does the BIA want the training room conversion to an emergency operation and command center functionality to include the ability to display multiple (scalable) video sources simultaneously on a single video display?<br><br>What would be the video signal sources and their resolution requirements? |
| Recommendation: | Utilize a four (4) input/four (4) window processing unit that is scalable.   |
| Justification:  | Using a multi-image video processor with less than four (4) windows in capability would require constant switching of input sources thus being inefficient with a higher likelihood of not seeing an event.  |

- 3.2.2. *Specific Requirements.*** Video devices shall manipulate and route composite, component, wide extended graphic array (WXGA), high-definition multimedia interface (HDMI), and display port signal types.
- 3.2.3. *Integration with other Systems.*** Video systems shall be functionally operated by the local low voltage control system via a touch-panel unit.

### 3.3. Signal Sources

- 3.3.1. *General Requirements.*** Various signals sources may provide input into the video system. Facility signal types shall adhere to advanced television systems committee (ATSC) standards.
- 3.3.2. *Specific Requirements.*** Native HD signals shall be able to provide high-bandwidth digital content protection (HDCP) encryption keys where necessary to allow a full distribution of media. Analog signals from various sources shall be scaled up to HD formats.

### 3.4. Displays

- 3.4.1. *General Requirements.*** Display units shall provide viewable imaging and text. Sizing of the unit shall be based on the room dimensions.
- 3.4.2. *Specific Requirements***
- 3.4.2.1.** Projection. Video projection units shall provide adequate brightness to be viewable under normal lighting conditions. Aspect ratio shall be 16:10. Projectors placed in rooms that may service as an

emergency operation center, or other regional response facility, shall use a minimum of 2 lamps simultaneously for redundancy should a lamp fail under use.

**3.4.2.2. Projection Screens.** Projection screens shall utilize a motorized, recessed, tab-tensioned screen, and shall match the aspect ratio of the projector used within the space. Screen gain shall be unity to provide maximum viewing sightlines.

**3.4.2.3. Projector Mounts.** Figure 13110-1 shows typical projector mounting scenarios. Actual hardware and installation requirements will vary by location, and shall be coordinated with the design team.

**Figure 13110-1: Typical Projection Unit Mounting**

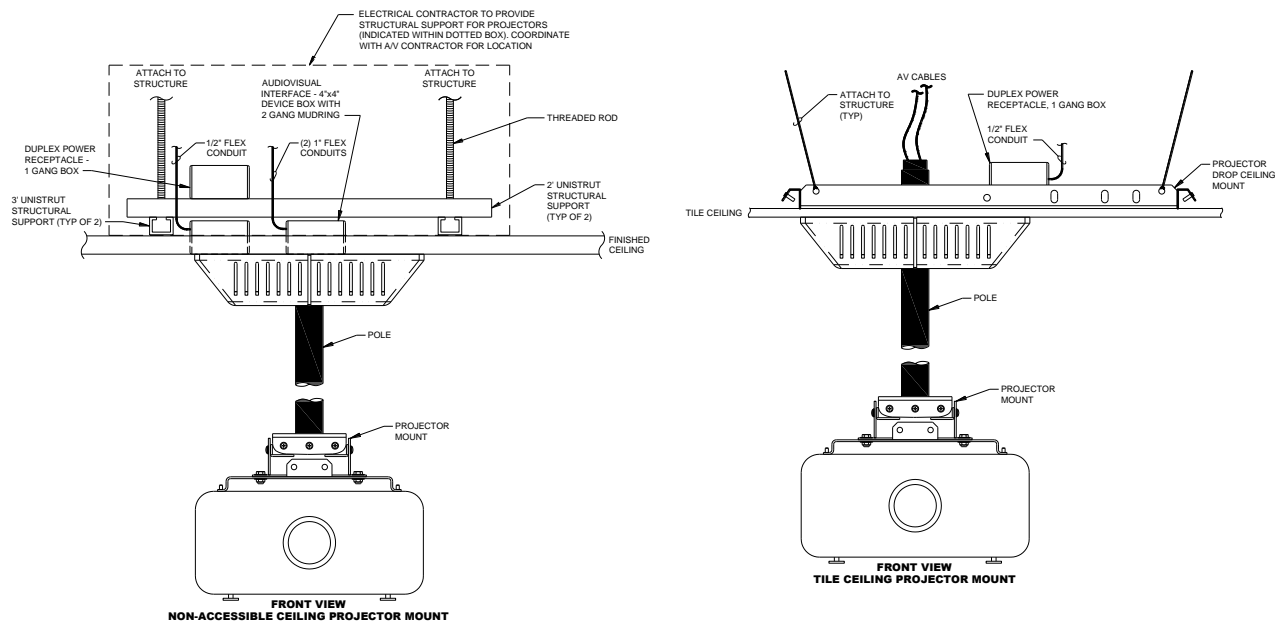

**3.4.2.4. Flat Panel.** Flat panel displays shall be professional quality models, and shall provide adequate brightness to be viewable under normal lighting conditions. Aspect ratio shall be HD (16:9). Flat panel units shall be remotely controllable via TIA -232-F (RS-232-F) serial data control or Ethernet connection. The use of infra-red emitters is not acceptable.

**3.4.3. Integration with other Systems.** Video displays shall receive signaling from video sources routed through the video distribution system. Control functionality shall be provided by the local low voltage control system.

The control system shall also operate the projection screen (where required) via dry relay contact closures.

### 3.5. Recording

- 3.5.1. *General Requirements.*** Video recording, typically used in the interview rooms, shall capture facial characteristics and expressions using both fixed and PTZ cameras.
- 3.5.2. *Specific Requirements.*** Recording shall be at a minimum rate of 24 frames per second.
- 3.5.3. *Integration with other Systems.*** The low voltage control system shall control all aspects of the functionality of recording units, including recording and playback. Playback of recorded images shall be through the video distribution system to the video display units.

### 3.6. Remote Arraignment

|                 |  |
|-----------------|--|
| Question/Issue: | Does the BIA want to define a particular connection requirement as a standard to ensure compatibility between all future locations? Is there an existing video/audio protocol suite or manufacturer currently specified as a standard? |
| Recommendation: | IP (Internet Protocol) in lieu of ISDN (Integrates Services Digital Network)   |
| Justification:  | All videoconferencing equipment manufacturers have shifted away from ISDN due to reliability issues with these data lines. IP is the industry standard.  |

- 3.6.1. *General Requirements.*** Remote arraignment systems shall provide a means of duplex audio and visual communications between BIA facilities and remote locations for the purpose of arraignment or testimony, in order to avoid the need for transporting detainees or witnesses.
- 3.6.2. *Specific Requirements.*** The technology designer of record shall work with the BIA to determine features and requirements. Real time, high quality and resolution imagery shall be transmitted through the IP infrastructure. Security grade, vandal resistant equipment shall be used in spaces other than courtrooms. Room finishes, environmental systems (security and acoustical), and lighting shall be coordinated to provide optimal performance of this system.
- 3.6.3. *Integration with other Systems.*** Remote arraignment systems shall be integrated with the facility's audio and video systems, and shall be controlled by the judge or clerk via the low voltage control system.



### 3.7. Tele/videoconferencing

- 3.7.1. **General Requirements.** Tele/videoconferencing shall provide a means of communications that is flexible and lends itself to large group participation coordination. The use of a high resolution video (HD) transceiver is required. This system can also be used for educational distance learning applications.
- 3.7.2. **Specific Requirements.** The technology designer of record shall work with the BIA to determine features and requirements. Real time, high quality and resolution (1080p) imagery shall be transmitted through the IP infrastructure to a high definition video transceiver.
- 3.7.3. **Integration with other Systems.** Tele/videoconferencing systems shall be integrated with the facility's audio and video systems, and shall be controlled by the low voltage control system. Conferencing systems require high speed data connections from the telecommunications switching and infrastructure systems.

### 13110-4. Control

- 4.1. **General Requirements.** The low voltage control system shall provide a robust mechanism for operating equipment from a central location. This system shall be designed with "ease of use" being the cornerstone of equipment selection and installation.
- 4.2. **Specific Requirements.** This system shall have the ability to utilize a myriad of signal topographies to operate dissimilar equipment types. Signal output types include: RS-232, 422 and 488 serial data streams, infrared (line of sight), dry relay contact closure, MIDI and radio frequency (RF) as necessary. The system shall be equipped with a custom touch or button panel, and shall also be remotely operable via IP connectivity, and control panels located at the judicial bench or court clerk. The system shall support software and firmware upgrades from both local and remote locations.
- 4.3. **Integration with other Systems.** The low voltage control system shall control operation of all audio and video systems, as well as lighting and temperature control, as needed. This system shall engage muting of all audio systems during a fire alarm/life safety event.

### 13110-5. Interview Rooms

- 5.1. **General Requirements.** Interview rooms shall have an overt camera in a vandal resistant safety housing with an overhead view of the entire interview room, including the entry door. Interview rooms shall also have a covert camera with a lower perspective, above the interview room table, viewing the upper torso and the interviewee's face. The covert camera shall capture facial expressions with high quality images. A microphone shall be located so that it captures clear recordings of the audible communication of the interviewee and the interviewer. Great care shall be exercised by every trade and specialty in the construction, material selection, sound isolation, and arrangement of all

components in the interview room, in order to maximize the quality and integrity of video and audio recordings.

- 5.2. **Specific Requirements.** The technology designer of record shall work with the BIA to determine where interview rooms shall be located and what components and characteristics shall be included in each location. The following are some locations that shall be considered:
  - 5.2.1. ***Law Enforcement.*** Consider and evaluate requirements for cameras and microphones for interview rooms in the criminal investigation and patrol areas.
  - 5.2.2. ***Detention.*** Consider and evaluate requirements for cameras and microphones for interview rooms in the detention area.
- 5.3. **Integration with other Systems.** Video and audio equipment shall be secured and operated within an adjacent interview control (monitoring) room.

#### 13110-6. Interview Control (Monitoring) Rooms

- 6.1. **General Requirements.** Interview control (monitoring) rooms shall contain and operate the video and audio recording equipment connected to cameras and microphones located in the interview rooms. The technology designer of record shall work with the BIA to determine where interview control (monitoring) rooms shall be located. Detention interview control rooms and law enforcement interview control rooms shall be combined where possible.
- 6.2. **Specific Requirements**
  - 6.2.1. Interview control rooms shall be secured and monitored, and shall provide enough room for 2 operators and consoles to monitor interviews and/or retrieve recordings for evidentiary and investigatory purposes.
  - 6.2.2. Video and audio shall be recorded by a centralized network video recorder or network digital video recorder. The recording and audio and video processing equipment shall be located within the TR, SR or DC. The recorder shall record feeds from each interview room with 2 video signals synchronized with an audio track.
  - 6.2.3. Equipment shall be powered by a UPS via generator circuit and have cable pathways to device locations.
- 6.3. **Integration with other Systems.** The interview control system shall be accessible by authorized personnel via the data network for retrieval of recordings.

#### 13110-7. Fitness

- 7.1. Flat panel televisions shall be placed in the fitness areas with the audio muted. Audio shall be routed through the exercise equipment or through a localized frequency modulation (FM) system.

- 7.2. Many fitness equipment manufacturers provide integrated video monitors for local viewing. Coordinate technology requirements for the selected fitness equipment.

**13120-1. Radio System Parameters**

- 1.1. A radio system is likely to be required to provide communication for mobile users based within a justice and detention facility. The technology designer of record shall work with the BIA to determine if such a system is required, and provide a technology design to support the owner selected radio system as necessary.

**10130-1. General**

- 1.1. 911 is the common telephone number that has been established to report an emergency, request emergency assistance, or both. When dialed it connects the caller to a Public Safety Answering Point (PSAP). The PSAP receives and responds to emergency calls requiring police, fire, emergency medical service, or all three. The 911 call center / dispatch system, also referred to as communications center / dispatch, is composed of various subsystems with equipment located in the radio/phone room and communications center / dispatch area.
- 1.2. 911 call center / dispatch systems are highly specialized. The technology designer of record shall work with a 911 systems consultant to properly identify all of the equipment requirements and systems interfaces required. The following is a list of typical systems. A diagram follows, showing typical system interfaces.

**10130-2. 911 Technology Systems****2.1. Equipment**

2.1.1. The following equipment is typically found within a radio/phone room:

- 911 telephone system Customer Premise Equipment (CPE).
- Telephone equipment – a switch or PBX for administrative non-emergency lines.
- Radio equipment.
- Recording equipment.
- Time synchronization.
- Computer Aided Dispatch (CAD) server.
- Geographic Information System (GIS) or map synchronization server
- Telecommunications grounding system.

2.1.2. The following equipment is typically found within the in the communications center / dispatch:

- 911 telephone system consoles, each consisting of one Central Processing Unit (CPU) and one or two monitors.
- Radio console consisting of one CPU and one monitor.
- CAD console consisting of one CPU and three monitors.
- Administration console consisting of one CPU and one monitor.
- Telecommunications grounding system.

2.1.3. The technology designer of record and 911 systems consultant shall confirm with the BIA whether the following equipment and supporting software shall be included:

- Voice recorder
- Automatic Call Distributer (ACD)
- Automatic Location Identification (ALI)
- Teleprinter

### 10130-3. System Interface Diagram

3.1. The following diagram has been adapted from a typical customer premises interface diagram developed by the National Emergency Number Association (NANA) in their recommended generic standards for E9-1-1 PSAP equipment.

**Figure 13130-1: Typical System Interface Diagram**

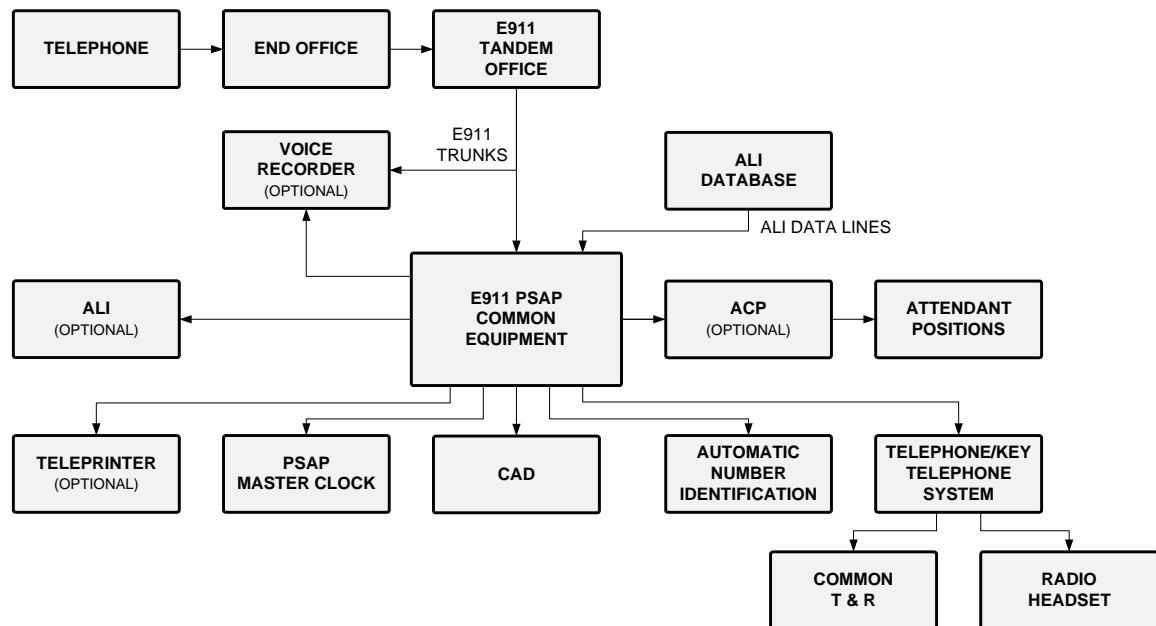

### 10130-4. Additional Resources

4.1. The technology designer of record shall refer to all of the technical standards developed by the National Emergency Number Association (NANA), 4350 North Fairfax Drive, Suite 750, Arlington, VA 22203-1695. (703)812-4600. [www.nena.org](http://www.nena.org).

**13140-1. Training and O&M Manuals**

- 1.1. The specifications shall require the contractor to provide training and operation and maintenance (O&M) manuals.

**13140-2. Training Parameters**

- 2.1. **General Requirements.** The technology designer of record shall specify that the installation contractor(s) shall provide training on the proper operation and routine maintenance of the various technology systems. Training shall be on-site and include hands-on demonstrations. The instructor shall be a qualified and experienced trainer. Training shall not commence until the system(s) are complete, tested, and fully operational.

**2.2. Trainer/Instructor**

- 2.2.1. The instructor leading the training session(s) shall be a qualified and experienced trainer. Where the contractor does not have a qualified and experienced trainer on staff, the contractor shall arrange to have qualified and experienced manufacturer representative(s) lead the training session(s).
- 2.2.2. The contractor shall have the project manager and/or foreman present during the training session(s) in order to assist the instructor by providing “hands-on” operational knowledge of the installation and operations of the systems.
- 2.2.3. For complex/sophisticated equipment, the contractor shall arrange to have the appropriate manufacturer representatives present during the training session(s).

**2.3. Schedule and Location**

- 2.3.1. The date and time of the training sessions(s) shall be coordinated with and approved by the BIA and designer of record.
- 2.3.2. The training sessions(s) shall occur within one month of substantial completion, unless otherwise approved by the BIA.
- 2.3.3. Training session(s) shall occur at the site, in order to provide the participants with “hands-on” experience.
- 2.3.4. Training may not necessarily occur in contiguous periods, depending upon the needs of the BIA (e.g. if a total of 8 hours of training is required, depending upon the needs of the BIA, it may be that 2 2-hour periods and 1 4-hour period spread across several weeks may be necessary).

- 2.4. **Follow-up Training.** Unless otherwise noted, provide one follow-up training session during the warranty period, scheduled at the request of the BIA, approximately 30 days after the initial training. This period shall allow the BIA and end-users enough time between dates to become familiar with the system. The contract shall not be considered complete until training has been completed.

## 2.5. Materials

- 2.5.1.** The final version of the O&M manual(s) shall be used as the primary training aid.
- 2.5.2.** Training materials and presentations shall be professional in appearance, organized, bound, and suitable for reuse by the BIA in the future. Provide training materials to each participant, plus an additional 2 copies to the BIA for future use. Training materials shall be provided on CD-ROM in addition to hardcopy.
- 2.5.3. *Recording.*** Unless otherwise noted, the contractor shall schedule and arrange the training session(s), shall provide qualified professional personnel and equipment to record the session(s), and shall provide the subsequent professionally produced recording to the BIA on DVD media.

## 2.6. Specific Requirements

### 2.6.1. *Time*

**2.6.1.1.** Confirm desired training time(s) with the BIA.

**2.6.1.2.** Specify the total hour(s) of required training using the approximations by system below.

**2.6.2. *Warranty Process.*** General overview: Provide 1 hour of training.

**2.6.3. *Telecommunications Systems.*** Provide the following training modules for telecommunications infrastructure, both inside and outside the facility, as appropriate:

- Overview of the communications cabling system – provide 1 hour of training.
- Backbone cabling – provide 1 hour of training.
- Horizontal cabling – provide 1 hour of training.
- Communications rooms and spaces – provide 2 hours of training.
- Data center – provide 4 hours of training.
- Outside plant – provide 1 hour of training.

**2.6.4. *Network/Phone Systems.*** Provide the following training modules for the network and phone systems, as appropriate:

- General overview – provide 4 hours of training.
- Each network system – provide 2 hours of training.
- VoIP – provide 4 hours of training.
- Copper – provide 1 hour of training.



- 2.6.5. *Low Voltage Systems.*** Provide the following training modules for the low voltage systems, as appropriate:
- Intercom – provide 4 hours of training.
  - Public address – provide 4 hours of training.
  - Synchronized clocks – provide 2 hours of training.
- 2.6.6. *Security Systems.*** Provide the following training modules for the security systems, as appropriate:
- Access control – provide 6 hours of training.
  - Intrusion detection – provide 6 hours of training.
  - Video surveillance – provide 6 hours of training.
  - Duress – provide 1 hours of training.
  - Detention control – provide 6 hours of training.
- 2.6.7. *Room Technology Systems.*** Provide the following training modules for the room technology systems, as appropriate:
- Sound reinforcement – provide 2 hours of training.
  - Video systems – provide 2 hours of training.
  - Low voltage control – provide 1 hour of training.
  - Interview rooms – provide 2 hours of training.
- 2.6.8. *Radio Systems.*** It is recommended that the vendor for the radio system provide training on the selected equipment. Provide the following training for the radio systems, as appropriate:
- Basic equipment familiarization – provide 2 hours of training.
  - Interoperability – provide 4 to 6 hours of training.
- 2.6.9. *911 Call Center / Dispatch.*** It is recommended that the 911 call center consultant provide training on the equipment and systems installed in the facility. Provide the following training for the 911 call center, as appropriate:
- Basic end-user operations – provide 8 hours of training.
  - System administrators – provide 8 to 16 hours of training.
  - Specialized system training (such as, maps, radios, CAD and security systems) – provided up to 8 hours of training for each new system integrated with the 911 call center.

**2.6.10. Follow Up Training Time.** Provide 2 hours of follow up training for each of the following:

- Telecommunications systems.
- Data network systems.
- Telephone systems.
- Low voltage systems.
- Security systems.
- Room technology systems.

### **13140-3. Operations and Maintenance (O&M) Manuals**

- 3.1. General Requirements.** The technology designer of record shall require that the operations, maintenance, and emergency manuals be provided by the contractor(s) to be used as the primary training aid. Direct the contractor to submit each manual in final form at least 15 days before commencing demonstration and training.
- 3.2. Manual Content:** Operations, maintenance, and emergency manuals content shall be specified in individual specification sections to be reviewed at the time of submittals. Reviewed manual content shall be formatted and organized as required by this section. Where applicable, clarify and update reviewed manual content to correspond to modifications and field conditions.
- 3.3. Format.** Manuals shall be submitted in the following format:
- 3.3.1.** Manual submittal shall be in paper and PDF electronic file format.
- 3.3.2.** Paper manuals shall be submitted in 3 copies. Include a complete operation and maintenance directory. Enclose title pages and directories in clear plastic sleeves.
- 3.3.3.** Assemble the PDF electronic file into a composite electronically-indexed file. Submit the PDF file on digital media that is acceptable to BIA. Name each indexed document file in the composite electronic index with its applicable item name. Include a complete electronically-linked operation and maintenance directory.
- 3.4. Directory Organization.** Include a section in the directory for each of the following:
- 3.4.1. Table of contents.** Include a table of contents for each emergency, operation, and maintenance manual.
- 3.4.2. List of systems.** List systems and subsystems alphabetically. Include references to the manuals that contain information about each system.
- 3.4.3. List of equipment.** List equipment for each system, organized alphabetically by system. List pieces of equipment that are not part of a system alphabetically in separate list.

### 3.5. Operations Manual

**3.5.1. *Content.*** In addition to the other requirements in this section, include required operational data in individual specification sections, along with the following information:

- System, subsystem, and equipment descriptions.
- Performance and design criteria.
- Operating standards.
- Operating procedures.
- Operating logs.
- Wiring diagrams.
- Control diagrams.
- Precautions against improper use.
- License requirements including inspection and renewal dates.

**3.5.2. *Descriptions.*** Include the following information for each systems:

- Product name and model number. Use designations for products indicated on the contract documents.
- Manufacturer's name.
- Equipment identification with serial number of each component.
- Equipment function.
- Operating characteristics.
- Limiting conditions.
- Performance curves.
- Engineering data and tests.
- Complete nomenclature and number of replacement parts.

**3.5.3. *Operating Procedures.*** Include the following information for each system, as applicable:

- Startup procedures.
- Equipment or system break-in procedures.
- Routine and normal operating instructions.
- Regulation and control procedures.
- Instructions on stopping.
- Normal shutdown instructions.
- Seasonal and weekend operating instructions.
- Required sequences for technology systems and related electric or electronic systems.
- Special operating instructions and procedures.

**3.5.4. *Systems and Equipment Controls.*** Describe the sequence of operation and diagram controls as installed.

### **3.6. Systems and Equipment Maintenance Manual**

**3.6.1. *Content.*** For each system, subsystem, and piece of equipment that is not part of a system, include source information, manufacturers' maintenance documentation, maintenance procedures, maintenance and service schedules, spare parts list and source information, maintenance service contracts, and warranty and bond information, as described below.

**3.6.2. *Source Information.*** List each system, subsystem, and piece of equipment that is included in the manual, identified by product name and arranged to match the manual's table of contents. For each product, list the name, address, and telephone number of the installer or supplier and maintenance service agent; cross-reference specification section number, title in project manual, and drawing or schedule designation or identifier where applicable.

**3.6.3. *Manufacturers' Maintenance Documentation.*** Manufacturers' maintenance documentation shall include the following information for each component part or piece of equipment:

- Standard maintenance instructions and bulletins.
- Drawings, diagrams, and instructions required for maintenance, including disassembly and component removal, replacement, and assembly.
- Identification and nomenclature of parts and components.
- List of items recommended to be stocked as spare parts.

**3.6.4. *Maintenance Procedures.*** Include the following information and items that detail essential maintenance procedures:

- Test and inspection instructions.
- Troubleshooting guide.
- Precautions against improper maintenance.
- Disassembly; component removal, repair, and replacement; and reassembly instructions.
- Aligning, adjusting, and checking instructions.
- Demonstration and training video recordings.

**3.6.5. *Maintenance and Service Schedules.*** Include service and lubrication requirements, list of required lubricants for equipment, and separate schedules for preventive and routine maintenance and service with standard time allotment.

**3.6.5.1.** Scheduled Maintenance and Service. Tabulate actions for daily, weekly, monthly, quarterly, semiannual, and annual frequencies.

**3.6.5.2.** Maintenance and Service Record. Include manufacturers' forms for recording maintenance.

**3.6.6. *Spare Parts List and Source Information.*** Include lists of replacement and repair parts, with parts identified and cross-referenced to manufacturers' maintenance documentation and local sources of maintenance materials and related services.

**3.6.7. *Warranties and Bonds.*** Include copies of warranties and bonds and lists of circumstances and conditions that would affect validity of warranties or bonds. Include procedures to follow and required notifications for warranty claims.

### **3.7. Emergency Manual**

**3.7.1. *Content.*** Organize manual into a separate section for each of the following:

**3.7.1.1.** Type of Emergency. Where applicable for each type of emergency indicated below, include instructions and procedures for each system, subsystem, piece of equipment, and component:

- Power failure.
- The designer of record shall identify any other emergencies with the BIA which shall be included in the emergency manual.

- 3.7.1.2.** Emergency Instructions. Describe and explain warnings, trouble indications, error messages, and similar codes and signals. Include responsibilities of BIA's operating personnel for notification of the installer, supplier, and manufacturer to maintain warranties.
- 3.7.2. *Emergency Procedures.*** Include the following information for each system, as applicable:
- Instructions on stopping.
  - Shutdown instructions for each type of emergency.
  - Operating instructions for conditions outside normal operating limits.
  - Required sequences for technology systems and related electric or electronic systems.
  - Special operating instructions and procedures.

**14000-1. Introduction**

- 1.1. This chapter shall be used as a guideline in the development of the food service kitchens within all new BIA Justice / Detention facilities. The specific layout of food service kitchens is the responsibility of the Designer of Record. This chapter provides general planning relationship information as well as functional requirements for kitchens. Kitchen design shall be in conformance with these guidelines unless exceptions to them are granted by the BIA.
- 1.2. Refer to Chapter 1, “General Information,” and Chapter 2, “Presentation of Data,” for required documents, drawing and specifications formats, and other design and submittal requirements not discussed in this chapter.
- 1.3. Additional design and submittal requirements may apply for projects with unusual or highly technical criteria.
- 1.4. As applicable, the Designer of Record shall incorporate the sustainability strategies identified in Chapter 3, “LEED Goals and Guidelines.”
- 1.5. The guidelines in this chapter should be used in conjunction with those in the other chapters in this handbook, and the Designer of Record should coordinate with the other project consultants to be sure all aspects of the justice / detention facility are effective and compatible.
- 1.6. All design features must be weighed carefully for their initial cost, long-term maintenance cost and needs, durability, and their impact on the environment.

**14010-1. General**

- 1.1. Specific program requirements of the food service kitchen shall be determined on a project-by-project basis but shall include the following considerations:
  - Number of meals served per day, including staff
  - Types of meal choices to be provided, including special dietary requirements
  - Type(s) of serving styles to be used, serving lines or tray delivery service
  - Storage capacity of kitchen in relationship to delivery schedule
- 1.2. Design site access and loading areas for food delivery vehicles used by local or regional suppliers. Coordinate dimensions, turning radius, pavement design, and other requirement with food delivery vehicles. Loading docks are not be required but may be considered if loading dock can be constructed with out significant structures or result in depressed grades that can trap storm water.
- 1.3. Design kitchen spaces to provide clear sight lines to occupied spaces. Layout should not result hidden spaces that are concealed from view.



**14020-1. General**

- 1.1. For kitchen design, follow all applicable current codes, standards, and laws. For a more general list of codes and standards that apply to BIA justice/detention facilities, refer to Chapter 1, “General Information.” During design, report any required deviations from codes and standards to the Contracting Officer.
- 1.2. Where two codes, standards, or laws are applicable to the topic under review, use the more conservative or more stringent. Consult with the BIA Office of Facilities Management and Construction (OFMC) to resolve any questions or conflicts regarding application of codes and standards.
- 1.3. Ensure that all commercial kitchens conform to the guidelines set forth in the latest edition of the U.S. Public Health Service’s (PHS) *Food Service Sanitation Manual*. The BIA is to provide additional input from the Indian Health Service on kitchen design requirements and water systems.

**14020-2. Applicable Codes and Standards**

- 2.1. The design criteria shall comply with the guidelines published by or contained in the following:
  - **Air-Conditioning and Refrigeration Institute (ARI):** Applicable regulations and standards for remote refrigeration systems, components, and installation.
  - **American Corrections Association (ACA) Standards:** Requirements as applicable to design of kitchens serving detention facility.
  - **American Gas Association (AGA):** Standards for gas-heated equipment. Automatic safety pilots to be provided on all equipment, where available. (Canadian Gas Association or alternate testing lab’s seals will be accepted if allowed by local code jurisdictions.)
  - **American National Standards Institute (ANSI):**
    - Standards A40.4 Air Gaps in Plumbing Systems and A40.6 Backflow Preventers in Plumbing Systems for water connection air gaps and vacuum breakers.
    - Standard B57.1 Compressed Gas Cylinder Valve Outlet and Inlet Connections for compressed-gas cylinder connections, and with applicable standards of the Compressed Gas Association (CGA) for compressed-gas piping.
    - Z21 series standards for gas-burning equipment. Provide labels indicating the name of the testing agency.
  - **American Society of Heating, Refrigerating and Air-Conditioning Engineers (ASHRAE):** Applicable regulations and standards for remote refrigeration systems, components, and installation.

- **American Society for Testing and Materials (ASTM):** C1036 Standard Specification for Flat Glass and C1048 Standard Specification for Heat-Treated Flat Glass—Kind HS, Kind FT Coated and Uncoated Glass.
- **American Welding Society (AWS):** D1.1 Design of Welded Connections.
- **Americans with Disabilities Act (ADA):** Requirements as applicable to the project.
- **The Montreal Protocol:** All refrigerants used for any purpose are to comply with the 1995 requirements of the Montreal Protocol, including subsequent revisions and amendments. No CFC refrigerants will be permitted on any BIA project.
- **National Electrical Code (NEC):** NFPA requirements for electrical wiring and devices included with food service equipment, ANSI C2 and C73, and applicable National Electrical Manufacturers Association (NEMA) and National Electrical Contractors Association (NECA) standards. All the commercial kitchen equipment should have UL (for electrical/ventilators), AGA (for gas), and NSF (for sanitation) labels. There are a number of items on the market missing one or more of these labels that can cause serious problems for the owner or architect if they are specified or approved as alternates.
- **National Electrical Manufacturers Association (NEMA):** Standard LD3 High-Pressure Decorative Laminates, Annex A: Application, Fabrication, and Installation.
- **National Fire Protection Association (NFPA):** Applicable sections for exhaust hoods, ventilators, duct and fan materials, hood fire suppression systems, and construction and installation.
- **National Sanitation Foundation (NSF):** Latest standards and revisions. Provide NSF seal of approval on each applicable item. (UL sanitation approval and seal accepted if allowed by local code jurisdictions.)
- **Refrigeration Service Engineers Society (RSES):** Applicable regulations and standards for remote refrigeration systems, components, and installation.
- **Sheet Metal and Air Conditioning Contractors' National Association (SMACNA):** Latest edition of guidelines for seismic restraint of kitchen equipment, as applicable to project location.

- **Underwriters Laboratories (UL):** Standards as applicable for electrical components and assemblies. Also, UL 300 Fire Testing of Fire Extinguishing Systems for Protection of Commercial Cooking Equipment, for wet chemical fire suppression systems for exhaust hoods/ventilators.

**14020-3. Personnel Qualifications**

- 3.1. All refrigeration components installation, repairs, and/or associated work on any refrigeration system are to be performed by a certified refrigeration mechanic.

14030-1. Kitchen Work Flow

1.1. The following diagram displays the work flow in a typical commercial kitchen.

Figure 14030-1: Work Flow Diagram

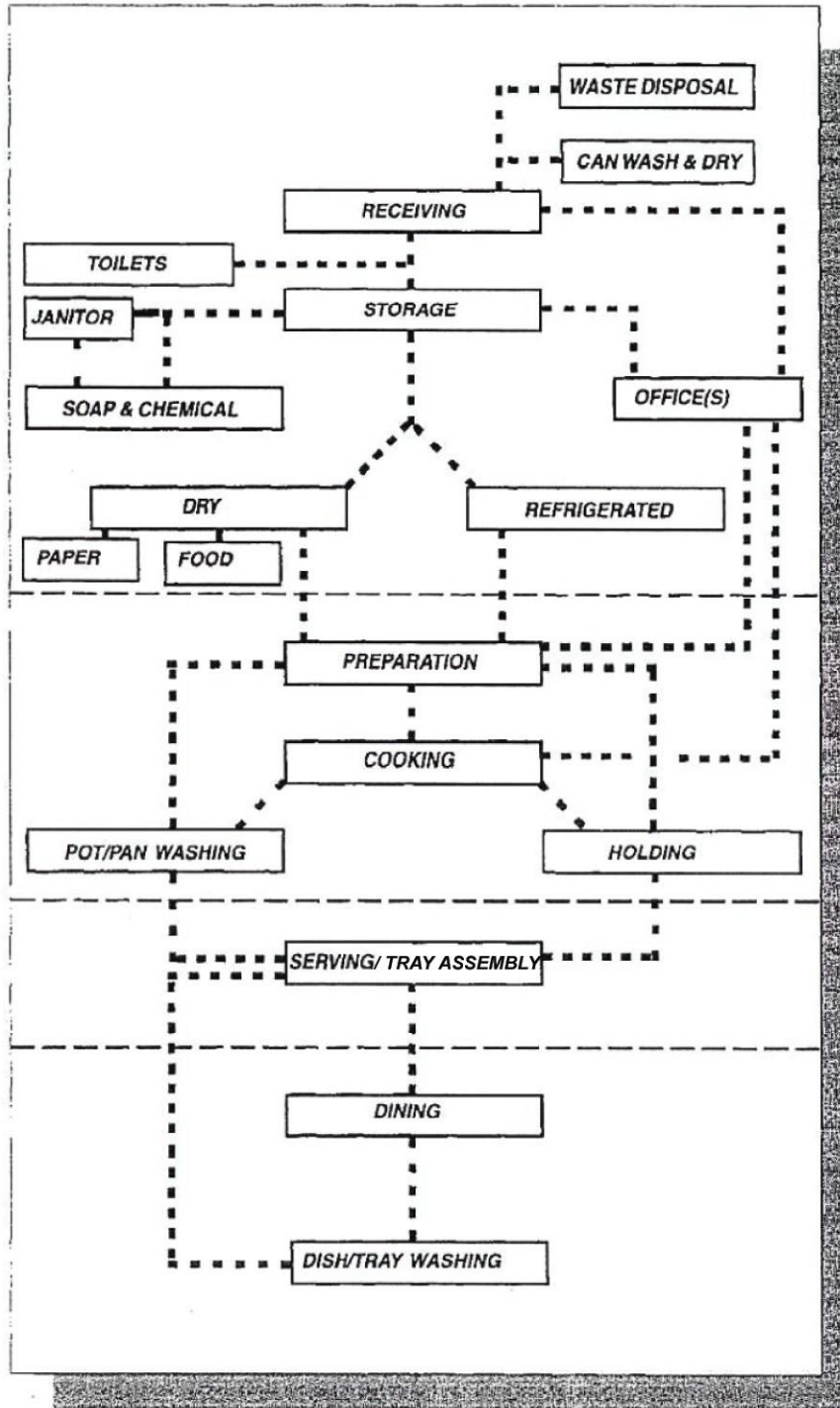

**14060-1. Food Service Work Areas**

- 1.1. **Receiving.** All deliveries will need to come in through the rear of the kitchen. Provide rear entrance to kitchen, minimum of 42 inches wide and 8 feet high, for equipment and large deliveries. Locate the receiving area near the manager's office, dry storage area, walk-in refrigerator, and walk-in freezer. Design receiving area wide enough for checking delivered packages and produce; without encroaching into circulation space between spaces and along exit routes. Where exterior kitchen entrance(s) open to the outdoors, provide fan that produces an air curtain to prevent flies and debris from entering the kitchen through door opening(s).
- 1.2. **Office.** The manager's office should be big enough for a desk, a chair, and filing cabinets. It should also include a data port and power outlet for a computer system. The office should contain a window that allows the manager to see into the kitchen work area and to monitor the rear entrance.
- 1.3. **Walk-In Refrigeration.** Every kitchen should have an adequate amount of walk-in cooler and walk-in freezer storage. The amount of such cold-storage space should be planned based on usable shelving square footage—approximately 1 square foot of shelf space for each meal divided equally between the cooler and the freezer. Walk-in boxes are very expensive to expand, so be generous with the initial amount of cold-storage space. If the justice / detention facility is in a rural area, double the size of refrigerated storage (i.e., 2 square feet of shelf space per meal) to accommodate less frequent but larger deliveries made to such areas. The storage shelving used within cold storage areas should be rust resistant and antimicrobial. The longest recommended shelving span is 48 inches; shelves longer than that may bend or buckle. There should be dunnage racks incorporated into the shelving layout. Shelving shall be rust-resistant epoxy coated wire or molded plastic type.
  - 1.3.1. Walk-in cooler panels will typically be 4 inches thick. The only exception is in the state of California, where 5-inch panels are required. In most cases, the walk-in boxes should sit in a 4-inch or 6-inch recessed pit. For a 6-inch recess, the architect should specify approximately 2-inch-thick finished floor materials, to be provided and installed by the general contractor.
  - 1.3.2. All compressors should be remote and semihermetic. If the compressor is to be located outdoors, provide outdoor housing for it and ensure that the unit can withstand extreme weather conditions, including hail damage. If the unit is to be housed within the building, ensure that it's specified as a water-cooled unit. Ensure that the refrigeration line is never more than 250 feet long. Use environmentally friendly refrigerants wherever possible.
- 1.4. **Restrooms.** Provide handicapped accessible restroom for kitchen staff. Provide one (1) 48 square foot unisex restroom. Verify requirements for restrooms space with the local building and health departments.

- 1.5. Dry-Storage Room.** Dry-storage space is calculated similarly to cold-storage space. Allow approximately 1 square foot of dry storage shelf space for each meal. For justice / detention facilities located in rural areas, allow extra dry-storage space to accommodate larger but less frequent deliveries to these facilities. The room should be lockable to prevent food loss. To prevent rodents from damaging stored goods, the walls should be sealed and have no cracks. Stainless steel wire shelving is adequate for this area; to prevent bending and buckling, shelving spans should be no longer than 48 inches. Wire-type shelving shall be provided in dry storage areas.
- 1.6. Janitorial Room/Area.** Design janitorial space for mop sink, chemical storage, and cleaning equipment that is directly accessible from the Kitchen. Provide mop sink, mop/broom rack, and service faucet installed 54 inches above finished floor. The mop sink should be constructed of stainless steel and be a minimum of 24 inches wide by 24 inches long.
- 1.7. Food Preparation.** To streamline the work process, both the wet and dry food prep areas should be located close to the walk-in cooler and freezer. Provide a minimum of one 24-inch-long by 24-inch-wide by 19-inch-deep sink for each prep area. There should be drawers and undershelf storage provided wherever possible. Undercounter space should also be allotted for trash receptacles. Provide wall shelving wherever possible, mounted 24 inches above the counter height.
- 1.7.1.** Provide the following basic food prep appliances, as required for each specific facility:
- Food slicer
  - Large floor-mounted mixer
  - Small countertop mixer
  - Food processor
  - Ingredient bins
- 1.8. Cooking Line.** The cooking line should be located out of sight of the serving line where possible. All cooking equipment should be on front-lockable casters to allow for the equipment to be moved around. While the cooking equipment selected should accommodate the style of menu proposed by the kitchen manager, a typical cooking line consists of the following:
- Six-burner range with oven
  - Tilt skillet
  - Jacketed steam kettle
  - Griddle
  - Steamer or combi-oven
  - Double-stacked convection oven

- 1.8.1. Exhaust Hood.** The cooking line should have an exhaust hood that overhangs the equipment per local fire codes. The bottom of the exhaust hood should be a minimum of 6 feet 6 inches above the finished floor and a maximum of 7 feet 6 inches. Makeup air can be introduced through the front of the exhaust hood. Makeup air should be tempered to maintain appropriate indoor air temperature. The exhaust hood should be fabricated as follows:
- 1.8.1.1.** The hood should be 18 gauge (1.3 mm) type 304 stainless steel external welded construction, in accordance with NFPA 96 Standard for Ventilation Control and Fire Protection of Commercial Cooking Operations, and the International Mechanical Code, including all applicable appendices. Exposed welds are to be ground and polished. Exhaust hoods are to be Underwriters Laboratories (UL) listed as available for length specified.
  - 1.8.1.2.** Furnish fluorescent-type light fixtures meeting or exceeding minimum lumen per local codes. Fixtures are to be UL listed for cooking equipment exhaust hoods, National Sanitation Foundation approved, with sealed safety lenses, and with stainless steel exposed conduit for wiring.
  - 1.8.1.3.** Furnish welded stainless steel formed duct collars at ceiling- or wall-duct connections. Before fabrication, verify the size and location of required duct connections.
  - 1.8.1.4.** Provide a pre-piped liquid chemical or water fire suppressant system, complying with applicable local regulations and NFPA standards. Wet chemical fire suppression systems are to comply with UL 300 standards. Water fire suppression systems are to comply with UL 199E Standard for Safety for Fire Testing of Sprinklers and Water Spray Nozzles for Protection of Deep Fat Fryers.
  - 1.8.1.5.** The water wash or ultraviolet control panel, where applicable, is to be made by the same manufacturer as the ventilator, with time clock control for automatic operation. Provide stainless steel trim strips for recessed control cabinet applications. Provide a stainless steel chase for a surface-mounted control panel, from the top of the panel to the ceiling, the full width and depth of the panel.
- 1.8.2.** The cooking line should have an adjacent assembly counter or work space to place cooked food or perform tasks that don't require cooking equipment.
- 1.9. Holding Area.** Provide holding area to store prepared food for tray assembly or service. Prepped and cooked food on the cooking line will go directly into a series of refrigerated, nonrefrigerated, or heated cabinets. It will remain there until it is moved to the serving line or tray assembly area. This cabinet area

should be close to the serving line or tray assembly area and within sight of the cooking line. Provide holding area cabinets with lockable casters.

**1.10. Serving Line (where applicable).** The serving line countertop should be at 34 inches above the finished floor and approximately 36 inches deep. It should also allow for a tray slide. The tray slide can be a 12-inch-deep rail running along the server's side of the counter, or it can be the countertop itself with a 12-inch extension to accommodate a tray. Equipment dropped into the counter or locations from where food will be served.

**1.10.1.** Provide sneeze guards at any serving area containing food visible to inmates. The sneeze guard should be either full-service style. Design sneeze guards to comply with local health code requirements.

**1.10.2.** Serving lines may also include a service window or "slot" where inmates may pick-up prepared trays without visibility to the serving line.

**1.10.3.** Typical serving line equipment is as follows:

- Drop-in cold pan
- Drop-in hot well
- Drop-in soup well

**1.11. Tray Assembly Area.** In facilities with tray delivery service, provide an assembly area for assembling inmate meals on individual trays. Locate assembly area adjacent to holding area and visible from the cooking area. Provide the following equipment with casters in the tray assembly area:

- Tray transport carts
- Tray conveyor
- Heated/refrigerated holding cabinets
- Hot food wells
- Cold food wells

**1.12. Pot and Pan Washing/Dishwashing Area.** The ware washing or dishwashing area should generally be enclosed in its own area adjacent to the kitchen and dining space. This will be a very wet area and employee traffic into it should normally be limited to those dropping off soiled pots, pans, and trays. There should be access to it from the kitchen side and in most cases a drop-off window from the dining room side to drop off soiled dishes and trays.

**1.12.1.** The ware washing area should contain the following equipment:

- Three-compartment sink
- Storage shelving
- Soiled-dish table
- Ware washer



- Booster heater
- Garbage disposal
- Condensate hood
- Slant-rack shelving
- Clean-dish table

**1.13. Beverage Area.** Typical beverage service may consist of the following: water, powdered drinks, iced tea and coffee. Typical equipment may include the following:

- Beverage Counter
- Ice machine
- Water filler
- Coffee brewer
- Ice tea brewer

#### **1.14. Equipment Specifications**

- All equipment shall be specified with correctional assemblies as applicable.
- Appropriate field modifications as required by the owner/operator shall be accommodated. Design shall limit inmates' ability to gather, store or hide potential weapons or contraband.

### **14060-2. Miscellaneous Items**

**2.1.** The following items are commonly overlooked when designing a commercial kitchen.

#### **2.1.1. Hand Sinks**

**2.1.1.1.** These should be located within sight of every work station. Ensure that a soap and towel dispenser is provided at each station. If any hand sink is located within 30 inches of a food prep area or work station, provide a 12-inch-high stainless steel splash guard.

#### **2.1.2. Security cabinet**

**2.1.2.1.** Provide security cabinet in Office area to store dangerous or contraband-type items i.e. knives, yeast, equipment keys, etc.

#### **2.1.3. Aisle Widths**

**2.1.3.1.** If a cart or truck will be passing two workers back to back, the aisle should be 60 inches wide plus the cart width.

**2.1.3.2.** If there will be only one person working in an area, the aisle width should be 36 inches.

- 2.1.3.3. If there will be one person passing another person working at a station, the aisle width should be 42 inches.
  - 2.1.3.4. If two people will be working back to back, the aisle should be 42 to 44 inches wide.
  - 2.1.3.5. If there will be one person passing two workers back to back, the aisle width should be 48 inches.
- 2.1.4. *Corner Guards***
- 2.1.4.1. Stainless steel corner guards should be located on all exposed corners within the kitchen.
- 2.1.5. *Floor Troughs***
- 2.1.5.1. Floor troughs should be provided at all kettles, tilt skillets and indoor cart washing facilities.
- 2.1.6. *Wall Backing***
- 2.1.6.1. Provide wall blocking to support wall shelves, wall-hung pot racks, rack shelves, hand sinks or any other wall mounted equipment.

**14070-1. General Metal Fabrication Requirements**

- 1.1. Remove burrs from sheared edges of metalwork, ease the corners, and smooth to eliminate cutting hazard. Bend sheets of metal at not less than the minimum radius required to avoid grain separation in the metal. Maintain flat, smooth surfaces, without damage to the finish.
- 1.2. Reinforce metal at locations of hardware, anchorages, and accessory attachments wherever metal is less than 14 gauge or requires mortised application. Conceal reinforcements to the greatest extent possible. Weld in place, on concealed faces.
- 1.3. Exposed screw or bolt heads, rivets, and butt joints made by riveting straps under seams and then filling them with solder will not be accepted. Where fasteners are permitted, provide Phillips-head, flat, or oval-head machine screws. Cap threads with acorn nuts unless they are fully concealed in inaccessible construction, and provide nuts and lock washers unless metal for tapping is at least 12 gauge. Match fastener head finish with the finish of the metal fastened.
- 1.4. Where components of fabricated metalwork are to be galvanized and involve welding or machining of metal heavier than 16 gauge, complete the fabrication and provide hot-dip galvanizing of each component, after fabrication, to the greatest extent possible (depending upon available dip-tank sizes). Comply with ASTM A123 Standard Specification for Zinc (Hot-Dip Galvanized) Coatings on Iron and Steel Products.

**1.5. Welding and Soldering**

- 1.5.1. Materials 18 gauge or heavier are to be welded.
- 1.5.2. Seams and joints are to be shop welded or soldered as the nature of the material may require.
- 1.5.3. Welds are to be ground smooth and polished to match the original finish.
- 1.5.4. Where galvanizing has been burned off, the weld is to be cleaned and touched up with high-grade aluminum paint.
- 1.5.5. Provide removable panels for access to mechanical and electrical service connections that are concealed behind or within food service equipment, but only where access is not possible and not indicated through other work.
- 1.5.6. Where the ends of fixtures, splashbacks, shelves, etc., are open, fill them by forming the metal or by welding sections, if necessary, to close the entire opening flush to walls or adjoining fixtures.
- 1.5.7. Rolled edges are to be as detailed, with corners bull-nosed, ground, and polished.

- 1.5.8. Equipment is to have 1/2-inch or larger radius coves in horizontal and vertical corners and intersections, per National Sanitation Foundation standards.

1.6. **Metal and Gauges**

- 1.6.1. Except as otherwise indicated, all exposed metalwork shall be fabricated of stainless steel, of the gauge indicated for the following components. Fabricate other components from not less than 20-gauge metal.

|                                      |          |
|--------------------------------------|----------|
| Tables and countertops               | 14 gauge |
| Sinks and drainboards                | 14 gauge |
| Shelves                              | 16 gauge |
| Fronts of drawers and door panels    | 18 gauge |
| Single-pan doors and drawer fronts   | 16 gauge |
| Enclosed base cabinets               | 18 gauge |
| Enclosed wall cabinets               | 18 gauge |
| Exhaust hoods and ventilators        | 18 gauge |
| Pan-type insets and trays            | 16 gauge |
| Removable covers and panels          | 18 gauge |
| Skirts and enclosure panels          | 18 gauge |
| Closure and trim strips over 4" wide | 18 gauge |
| Hardware reinforcement               | 12 gauge |
| Gusset plates                        | 10 gauge |