

**BAGHDAD POLICE COLLEGE  
BAGHDAD, IRAQ**

**SIGIR PA-06-078.2**

**SIGIR PA-06-079.2**

**JANUARY 29, 2007**



## SPECIAL INSPECTOR GENERAL FOR IRAQ RECONSTRUCTION

January 29, 2007

MEMORANDUM FOR COMMANDING GENERAL, MULTI-NATIONAL FORCES - IRAQ  
COMMANDING GENERAL, GULF REGION DIVISION, U.S.  
ARMY CORPS OF ENGINEERS  
DIRECTOR, IRAQ RECONSTRUCTION MANAGEMENT OFFICE  
DIRECTOR, AIR FORCE CENTER FOR ENVIRONMENTAL  
EXCELLENCE

SUBJECT: Report on Project Assessments of Reconstruction Work Performed Under Task Orders 06 and 29 at the Baghdad Police College, Baghdad, Iraq (Report Numbers SIGIR PA-06-078.2 and PA-06-079.2)

We are providing this project assessment report for your information and use. We assessed the in-process construction work being performed under Task Orders 06 and 29 at the Baghdad Police College, Baghdad, Iraq to determine their status. These assessments were made to provide you and other interested parties with real-time information on relief and reconstruction projects underway and in order to enable appropriate action to be taken, if warranted. The assessment team included an engineer/inspector and two auditors/inspectors.

The Gulf Region Division in responding to a draft of this report generally concurred with the draft report's conclusions. However, the Gulf Region Division did not concur with all of the draft report's recommendations. In view of the Gulf Region Division's admission that "established international standards" were not followed by the contractor and enforced by the government, we continue to believe that our recommendations are appropriate. The construction issues identified throughout this report need to be corrected or they will continue to reoccur. We will work with the Gulf Region Division to reach a mutually satisfactory resolution.

We appreciate the courtesies extended to our staff. If you have any questions please contact Mr. Brian Flynn at [brian.flynn@sigir.mil](mailto:brian.flynn@sigir.mil) or at 914-360-0607. For public or congressional queries concerning this report, please contact SIGIR Congressional and Public Affairs at [publicaffairs@sigir.mil](mailto:publicaffairs@sigir.mil) or at 703-428-1100.

A handwritten signature in black ink that reads "Stuart W. Bowen, Jr." followed by a period.

Stuart W. Bowen, Jr.  
Inspector General

# Special Inspector General for Iraq Reconstruction

SIGIR PA-06-078.2  
SIGIR PA-06-079.2

January 29 2007

## Baghdad Police College, Baghdad, Iraq

### Synopsis

**Introduction.** This project assessment was initiated as part of our continuing assessments of selected sector reconstruction activities for Security and Justice. The overall objectives were to determine whether selected sector reconstruction contractors were complying with the terms of their contracts and task orders and to evaluate the effectiveness of the monitoring and controls exercised by administrative quality assurance and contract officers. We conducted this project assessment in accordance with the Quality Standards for Inspections issued by the President's Council on Integrity and Efficiency. The assessment team included a professional engineer/inspector and an auditor/inspector.

The Coalition Provisional Authority awarded a contract to Parsons Delaware, Inc, to construct and renovate the Baghdad Police College<sup>1</sup> in March 2004. Upon the dissolution of the Coalition Provisional Authority, the Joint Contracting Command – Iraq/Afghanistan became the contracting agent. The U.S. Army Corps of Engineers Gulf Region Division and the Project and Contracting Office are responsible for the efficient and effective execution and administration of design-build contracts for the reconstruction of Iraq. The Joint Contracting Command – Iraq/Afghanistan provided the Gulf Region Division and Project and Contracting Office with a roles and responsibilities matrix in order to specify the functions of each organization.

There were two task orders under the contract associated with work at the Baghdad Police College – Task Orders 06 and 29. Task Order 06 provided for a Public Safety Training Academy to supplement and expand the training facilities to train all departments of the Ministry of Interior. Task Order 29 was to provide all labor, materials, and services necessary to construct new buildings and/or renovate, improve, and expand existing buildings to supplement the Baghdad Public Safety Training Academy.

**Project Assessment Objectives.** The objective of this project assessment was to provide real-time relief and reconstruction project information to interested parties in order to enable appropriate action, when warranted. Specifically, we determined whether:

1. Project components were adequately designed prior to construction or installation;
2. Construction or rehabilitation met the standards of the design;
3. The contractor's Quality Control plan and the U.S. Government's Quality Assurance program were adequate;
4. Project sustainability was addressed; and
5. Project results were consistent with original objectives.

---

<sup>1</sup> The Baghdad Police College is also referred to in various documents related to it as the Baghdad Police Academy, Baghdad Public Safety Training Academy, and Baghdad Police Training Academy. For consistency within this report, unless used in a verbatim quotation, we refer to it as the Baghdad Police College.

We visited the Baghdad Police College on 6 separate occasions – 22 August 2006, 4 September 2006, 21 September 2006, 10 November 2006, 1 December 2006, and 8 December 2006. The intent of the 22 August 2006 site visit was to assess the entire project using the announced objectives. However, we identified significant plumbing issues in the cadet barracks that required separate reporting<sup>2</sup>. In September 2006, we visited the Baghdad Police College twice to determine if the Gulf Region Division had required the contractor to take corrective actions regarding the plumbing issues we identified in the first visit. The previous issues noted had not been adequately addressed as of our two September site visits. The Gulf Region Division advised us the plumbing issues had been corrected in early November 2006; therefore, we visited the Baghdad Police College on 10 November 2006 to assess the quality of the plumbing rework. We identified similar and additional plumbing deficiencies. We made two additional site visits in December 2006 to assess the remainder of the project that we did not have sufficient time to review during earlier site visits.

**Conclusions.** The assessment determined that:

1. All project components were not adequately designed prior to construction. The contractor did not provide and the government did not review the required number of design drawings for 30% and 60% submittals. For the design drawings reviewed, the government determined the submittals were generally incomplete and inadequate. For the 90% design drawing submittals, the government concluded that the drawings were “not acceptable as 90% submittal as these drawings are incomplete, inaccurate, and substandard.”

For several buildings, the 100% design drawing submittals were “rejected” by the government reviewer. In addition, the government reviewer did not sufficiently review the design submittal to realize that the task order required that the kitchen for the dining facility was not included. Further, the contractor failed to provide quality, detailed design construction drawings. Specifically, the contractor’s drawings lacked significant details, such as the rough-in and finish-out for the installation of plumbing fixtures, the need for an adequate number of cleanouts, and the use of building expansion joints. To date, the government has paid the contractor approximately \$2.6 million for its design submittals.

2. The majority of the work observed did not meet the standards of the contract and task orders. We identified significant construction deficiencies, such as poor plumbing installation, expansion cracks, concrete segregation and honeycombing, reinforcement bar exposure, and poor brickwork. In addition, the construction and equipment installation was performed at a low level of workmanship by the contractor and did not comply with the international standards required by the contract and task orders.

Construction was so poor for one facility that the contractor issued a Nonconformance Report and work was stopped while independent assessments were done to determine if the construction deficiencies could be corrected. The independent assessments determined that it would be too costly to attempt to correct the structural construction deficiencies. Even though the subcontractor agreed to “take financial responsibility for the engineering fix,” this facility was removed from the scope of work under the contract after the government paid

---

<sup>2</sup> See SIGIR report, PA-06-078.1 & 079.1, “Quick Reaction Report on the Baghdad Police College, Baghdad, Iraq,” 27 September 2006.

approximately \$350,000 for the poor construction work, and it will require approximately \$100,000 to demolish the facility.

In addition, when we inspected the contractor's rework of leaking plumbing, we discovered similar and additional plumbing deficiencies. Further, when the U.S. Army Corps of Engineers Gulf Region Central removed multiple task order requirements from the scope of work under the contract, at least two partially constructed facilities were left that pose potential safety hazards to the Baghdad Police College occupants.

3. The contractor's Quality Control plan was sufficiently detailed, including the use of daily Quality Control reports and Nonconformance Reports to document construction deficiencies; yet the contractor's Quality Control program implementation failed to identify significant construction deficiencies, such as poor plumbing installation practices and substandard expansion joints. Even when the Nonconformance Reports identified significant construction deficiencies, there was no assurance that corrective actions would be taken. In addition, it appears the contractor did not provide the Nonconformance Reports to the government's Contracting Officer Representative, as was required by the Quality Control plan.

The government Quality Assurance program was essentially non-existent in monitoring the contractor's Quality Control program. Neither the U.S. Army Corps of Engineers, Gulf Region Central Project Engineer nor the Quality Assurance Representative reviewed the contractor's daily Quality Control reports. In addition, the Quality Assurance Representatives were used to track project progress and not to identify quality issues. The Quality Assurance Representatives did not identify any construction deficiencies in the daily Quality Assurance reports. Consequently, the U.S. Army Corps of Engineers was not aware of significant construction deficiencies at the project site.

The U.S. Army Corps of Engineers Gulf Region Central will receive a fee of 4 percent of the cost of both task orders for what it stated was a "limited Quality Assurance role," which consisted of using the on-site Quality Assurance Representatives to "track progress toward" project completion instead of identifying construction deficiencies. In fact, according to U.S. Army Corps of Engineers Gulf Region Central personnel, the daily Quality Assurance reports given to the Quality Assurance Representatives did not "contain a block for quality issues." It was the U.S. Army Corps of Engineers Gulf Region Central's belief that the Project and Contracting Office "assumed the responsibility for project oversight and review of the Quality Assurance Reports..." As a result, the U.S. Army Corps of Engineers Gulf Region Central will be paid approximately \$2.5 million for simply tracking the progress of the project completion instead of enforcing the procedures set forth in its own guidance regarding the Quality Assurance program.

Finally, as a result of the lack of oversight and poor project management by the U.S. Army Corps of Engineers, the government paid Parsons approximately \$5.3 million in base and awards fees for substandard work.

4. Sustainability was addressed in the task order requirements, yet not adequately administered by the U.S. Army Corps of Engineers. The task order specifications required a one-year warranty on all materials and workmanship for the buildings and facilities constructed or renovated in this project after issuance of the Taking-

Over-Certificate. The U.S. Army Corps of Engineers Gulf Region Central used Beneficial Occupancy forms to document the date of transfer of buildings and facilities to the Baghdad Police College. However, a majority of the buildings were transferred to the Baghdad Police College without testing the adequacy and functionality of the basic utilities installed. At the time of the transfer, several buildings lacked any effort by the government to test the electrical, fire alarm and communication systems, and plumbing for the potable and the waste water systems.

The Beneficial Occupancy forms were signed in May and June 2006, and some of the untested buildings (including the four instructors' barracks) have yet to be occupied because of the lack of power and water. Consequently, 7 months of the 12 month warranty have already passed without any testing to determine if construction deficiencies exist. Since plumbing issues are still present in the cadet barracks, we are concerned the same plumbing installation practices were done in the instructors' barracks. In addition, since an additional power source is required to operate some of these buildings, it is possible the 12-month warranty will expire prior to even a simulated full load testing and occupancy of the buildings.

Further, this report identified what we felt to be low quality plumbing fixtures used by the contractor, which will present the Baghdad Police College with continual maintenance problems. Finally, the as-built drawings submitted by the contractor, in many cases, do not reflect the work that was actually done. Accurate information in the as-built drawings is needed for proper operations and maintenance, effective warranty enforcement, and future repair and rehabilitation work.

5. The Baghdad Police College construction and renovation project results were not consistent with the original contract and task order objectives. The contract Statement of Work called for providing the "Iraqi people with necessary basic public facilities and infrastructure with sufficient space accommodations and reliable public works, electrical, plumbing, mechanical, and communications resources that are easy to maintain, upgrade and repair..." The completed barracks buildings continue to experience significant plumbing failures and the massive expansion cracks on the interior and exterior of the buildings will leave the Iraqis with continual maintenance issues.

In addition, this project's construction costs were originally estimated to be approximately \$73 million. In an effort to complete the project, which was experiencing significant cost overruns and schedule slippages, 24 items had to be removed from the scope of work under the contract including the laundry facility, fire protection, and communications building. In the cases of the laundry facility and the communications building, the Baghdad Police College was left with structures 51% and 38% complete, respectively; while other items, such as the driving course, connection to the power grid, and structural repairs were de-scoped with no work done at all.

The government estimates it will pay Parsons approximately \$62 million for work both fully and partially completed. Additional contracts with other contractors in excess of \$8 million have been awarded to complete some of the construction work not finished by Parsons. However, the majority of the de-scoped items, which were originally determined to be essential to a functioning police training college, will either be left as a shell (i.e. communications building) or not even

attempted (i.e. driving course and fire protection). The U.S. Army Corps of Engineers has been unable to provide the original estimated costs and amount paid for each of the de-scoped items; therefore, it is not possible to determine the additional amount of funding required to complete all of the objectives of the task orders.

The Baghdad Police College construction and renovation project results were not consistent with the original contract and task order objectives because the project was poorly designed, constructed, and the contractor and the U.S. Army Corps of Engineers Gulf Region Central Project Engineer and Quality Assurance Representatives did not effectively manage the project.

**Recommendations.** We recommend that the Commanding General, Gulf Region Division:

1. Require the contractor to replace all existing plumbing fixtures and fittings in all newly constructed buildings to comply with the International Plumbing Code in accordance with contract specifications. Specifically, eliminate the use of cemented joints, abnormal fittings, and improperly sealed pipe connections. In addition, require the use of cleanouts, traps, and proper sealing techniques.
2. Require the U.S. Army Corps of Engineers Gulf Region Central Quality Assurance Representatives to be responsible for identifying quality issues as required by the contract and USACE ER 1180-1-6, instead of simply tracking project progress.
3. Require the U.S. Army Corps of Engineers Quality Assurance Representatives to become thoroughly familiar with the International Plumbing Code standards.
4. Require the U.S. Army Corps of Engineers Project Engineer and Quality Assurance Representatives to supervise the contractor's installation of all plumbing rework to ensure compliance with the International Plumbing Code.
5. Require the U.S. Army Corps of Engineers Gulf Region Division Resident Engineer to thoroughly review the contractor submitted as-built drawings. Specifically, walk through each facility and compare the as-built drawings to the actual construction completed.
6. Require the contractor to resubmit, at no cost to the government, accurate as-built drawings for any deviations noted during the walk through of the facility.
7. After completing the thorough review of the as-built drawings, verify the contractor's individual charges against the confirmed work performed. Determine if the contractor was paid for work claimed, but not performed. Specifically, determine if the contractor charged, and was paid, for engineered expansion joints in the instructors' barracks. If so, then recover the money paid from the contractor.
8. Require the U.S. Army Corps of Engineers Quality Assurance Representatives to be present for any future plumbing tests. In addition, require the Quality Assurance Representatives to document the tests performed, equipment used, and test setup information.
9. Require the Project Engineer and Quality Assurance Representatives to review the 95 Nonconformance Reports submitted by Parsons for construction deficiencies and determine if corrective actions were previously taken. If corrective actions were not taken, require that necessary corrective actions be taken.

**Management Comments.** The Gulf Region Division generally concurred with the draft report's conclusions. However, the Gulf Region Division did not concur with all of the draft report's recommendations. Instead, the Gulf Region Division emphasized that "not one graduation has been delayed, nor has a single class of cadets been delayed."

**Evaluation of Management Comments.** The Gulf Region Division's comment regarding the ability of the Baghdad Police College to graduate cadets is irrelevant to the issues raised in this report. The contract and task orders specifically required that the Baghdad Police College construction comply with international building standards and diligent quality management by the contractor and the government. The Gulf Region Division, in its comments, confirmed that international building standards were not followed and the quality management program of the contractor and the government was not adequate. The objective of the contract and task orders was to provide the Baghdad Police College staff an adequate training facility, including cadet barracks and classrooms, to train a substantial number of cadets. Instead, the poor construction and oversight forced the Baghdad Police College to relocate cadets from one barracks to another and, in at least one case, into a classroom as temporary living quarters in order to protect the cadets from leaking urine and fecal matter within the cadet barracks.

In view of the Gulf Region Division's admission that "established international standards" were not followed by the contractor and enforced by the government, we continue to believe that our recommendations are appropriate. The Baghdad Police College plumbing must comply with International Plumbing Code standards or the problems identified throughout this report will continue to reoccur. We will work with the Gulf Region Division to reach a mutually satisfactory resolution.

**Indications of Potential Fraud.** During this inspection, we found indications of potential fraud and referred these matters to the Assistant Inspector General for Investigations, Office of the Special Inspector General for Iraq Reconstruction, for such actions deemed appropriate.



# Table of Contents

---

<b>Synopsis</b>	i
<b>Introduction</b>	
Objective of the Project Assessment	1
Pre-Site Assessment Background	1
Contract, Task Order, and Costs	1
Project Objective	1
Description of Facility (pre-construction)	2
Scope of Work of the Contract	2
Current Project Design and Specifications	5
<b>Items Removed from the SOW of Task Orders</b>	6
<b>Site Assessment</b>	6
Design and Specification Review Process	7
Quality of Construction	13
Quality of Parts	28
Use of Beneficial Occupancy Form	32
Quality Management Program	35
Review of Contractor Payment Invoices	54
Test Results and As-Built Drawings	55
<b>Base and Award Fees</b>	64
<b>Project Sustainability</b>	66
<b>Conclusions</b>	67
<b>Recommendations</b>	70
<b>Management Comments</b>	71
<b>Evaluation of Management Comments</b>	71
<b>Appendixes</b>	
A. Scope and Methodology	100
B. Contract, Task Orders, and Modifications	101
C. De-Scoped Task Order Items	105
D. Work Completed	107
E. Work In Progress/Work Partially Completed	140
F. Systemic Problems with BPC Buildings	153
G. Work Completed Since Initial Site Visit	155
H. Award Fees	164
I. Complete Text of Gulf Region Division Comments	165
J. Acronyms	175
K. Report Distribution	177
L. Project Assessment Team Members	179

# Introduction

---

## Objective of the Project Assessment

The objective of this project assessment was to provide real-time relief and reconstruction project information to interested parties in order to enable appropriate action, when warranted. Specifically, we determined whether:

1. Project components were adequately designed prior to construction or installation;
2. Construction or rehabilitation met the standards of the design;
3. The contractor's Quality Control (QC) plan and the U.S. Government's Quality Assurance (QA) program were adequate;
4. Project sustainability was addressed; and
5. Project results were consistent with original objectives.

## Pre-Site Assessment Background

### Contract, Task Order, and Costs

The Baghdad Police College<sup>3</sup> (BPC) project was completed under Contract W914NS-04-D-0009, dated 26 March 2004, as a cost-plus-award-fee for the base period. The contract was between the Coalition Provisional Authority and Parsons Delaware, Inc., Pasadena, California (Parsons). Contract W914NS-04-D-0009 minimum, including option periods, is \$500,000 and the maximum total of all orders under the contract is \$900,000,000.

There were two task orders associated with this particular contract – Task Order (TO) 06 and TO 29.

For a detailed list of the contract TOs, and modifications, see Appendix B.

### Project Objective

The overall objective of TO 29 was to provide all labor, materials, and services necessary to construct new buildings and/or renovate, improve, and expand existing buildings to supplement the Baghdad Public Safety Training Academy. TO 06 stated that the Public Safety Training Academy will be constructed in conjunction with the existing National Police Academy and will supplement and expand the training facilities to accommodate training for all departments of the Ministry of Interior. The National Police Academy had the capacity to house and train approximately 1,200-1,500 cadets; the initial goal of the TO was to increase the Academy capacity to 4,000 cadets. Modification 9 increased the ultimate goal from 4,000 cadets to 10,000 cadets. Basic infrastructure (electricity, water, and sewer<sup>4</sup>) improvements

---

<sup>3</sup> The Baghdad Police College is also referred to in various documents related to it as the Baghdad Police Academy, Baghdad Public Safety Training Academy, and Baghdad Police Training Academy. For consistency within this report, unless used in a verbatim quotation, we refer to it as the Baghdad Police College.

<sup>4</sup> The term soil pipe, waste water pipe, sewer pipe, and drainage pipe are interchangeably used throughout the report for waste water disposal system.

and the construction of additional target ranges were the most urgent needs of the academy.

Coalition Forces designated 2006 as the “Year of the Police” with the ultimate goal of training 135,000 new police cadets by the end of the year. Well trained and resourced police cadets are important for winning the confidence of the Iraqi people; further, as the Iraqi forces stand up, American Forces will be able to stand down and ultimately decrease the number of U.S. troops in Iraq. The BPC, which trains cadets from Iraq’s 18 provinces, is arguably the most important facility to train Iraqi police cadets. Therefore, the need to complete the facility quickly was a priority.

### **Description of the Facility (pre-construction)**

The description of the facility (pre-construction) was based on information obtained from the contract, the U.S. Army Corps of Engineers (USACE) project file, and BPC personnel. The project site is located at the existing Baghdad Police College campus, in Baghdad, Iraq. The surrounding area consists of residential homes and government buildings, such as the Ministries of Interior and Oil. The BPC previously was a three-year officer training facility. However, with an emphasis of providing a large number of cadets through Basic Police Training, this facility was determined to be insufficient. The existing facility consisted of a number of buildings, constructed approximately between 1935 to 1944. The existing buildings were in various stages of decay (Site Photos 1 and 2).



**Site Photos 1 and 2. Existing buildings at the Baghdad Police College**

### **Scope of Work of the Contract**

The intent of TO 06 was to “construct and/or renovate buildings to expand and supplement the existing” Baghdad Police College. Specifically, TO 06’s scope of work (SOW) required the contractor to:

- Provide complete site-wide electrical upgrades to include detailed site surveys, new substations, overhead power lines, service drops, and grounding to existing buildings.
- Provide permanent site lighting at the main entrance gate, the rear gate, and the security checkpoint located west of the main gate.
- Renovate existing generator building to include new doors, windows, improved walls, and secured locking mechanism in addition to equipment required for electrical upgrades.

- Provide power and permanent lighting to each of approximately 25 guard watchtowers.
- Provide complete site-wide water and sewage upgrades to handle the 10,000 person capacity to include detailed site surveys, new services to existing buildings (where required), site drainage, etc. The drainage problem is most severe in the area around the old range. Provide upgraded water and sewer drops to all buildings as required. Repair city sewer pipe and renovate two existing city sewage pump stations to ensure that increased outputs can be accommodated by the city system.
- Provide upgraded electrical service from main substation to buildings AB, AC, AD, AE, AF, AG, AH, AI, AJ, AK, AL, AM, AN, AO, AP, AQ, AR, AS, AT, and AU.
- Refurbish existing buildings SO, SI, SK, and SJ.
- Provide upgraded electrical service to buildings AA and AZ.
- Provide upgraded water and sewer service to all “A” buildings as required and to buildings SO, SI, SK, & SJ.
- Convert buildings AO and AN into instructor’s housing. Each building shall have 14 single bedrooms each with a window and private door. Building AO shall have 5 showers, 5 toilets, and 5 sinks entirely for male use. Building AN shall have a dedicated bathroom for women including 1 toilet, 1 sink, and 1 shower. Men’s facilities in building AN shall include 4 showers, 4 sinks, and 4 toilets.
- Building BE, Dining Hall – provide new electrical service drop sized sufficiently to accommodate air conditioning load. Provide for a cash collection system for paying customers to eat at facility.
- Building BF – existing music hall shall become new commercial grade kitchen able to serve an expected academy population of 4,000+.
- Building BA – armory administration building – renovation of building is complete. Upgraded electrical, water, and sewer services need to be brought to the building.
- Demolish existing roofed car park and replace with motor pool including a Petroleum, Oil, and Lubricants (POL) facility. Motor pool shall include:
  - Car lifts
  - Maintenance shop
  - Controlled access tool room
  - Billeting facility for two maintenance workers
  - Re-fueling station
- Install 2 new 30 meter (m) pistol ranges (30 lanes) and 2 new 100m rifle ranges (30 lanes) with permanent lighting and centrally located bathroom facility.
- Provide power and permanent lighting to 2 existing 30m pistol ranges (denoted as R2 and R3) on contract attachment 6.
- Provide new range area administration/training building with 10 range classrooms (20 students each), 5 offices, 6 firearms training simulator (FATS) rooms, storage closets, and restrooms.

- Construct central laundry with drop-off and pick-up facility in each barracks.
- Construct new dining hall that will seat a minimum of 1500 seating per shift, four shifts per meal. Dining hall shall attach to new kitchen. Provide for a cash collection system for paying customers to eat at the facility.
- Construct new contractor workshop to replace existing workshop located in billeting facility. Approximate dimensions are 48m x 5.5m.
- Provide new electrical service drop to building BB, the new medical clinic, and building BC, the existing warehouse.
- Install new rain gutters on all existing buildings.
- Construct Physical Training (PT) field with pull-up bars, mats, etc. north of building BC.
- Construct new teaching facilities for 3,300 students (minimum).
- Installation of approximately 3,216 linear meters of 3m high t-walls.
- 14 additional watch towers.
- 1 additional secure gate utilizing the design provided by MNSTC-I that shall be cut into the exterior masonry wall.
- 3 additional entry control points to include raising gates.
- Additional 200 3m high t-walls to be located at the Academy to be used for rapid deployment to emergency areas.
- Renovate 4 additional instructor barracks in the A series buildings to compliment current renovations.
- Renovate one additional instructor barracks similar to current renovations, except that the open building shall be divided into seven instructor rooms and the remainder of the building renovated but left open for multipurpose usage.
- Conduct and provide site drainage plan, assessment of existing structures, design, site preparation and construction and/or renovation of designated structures.

TO 0029's SOW required the contractor to:

- Renovate and restore the existing police athletic club facilities.
- Renovate storage closets located beneath parade field bleachers to allow for storage of chairs, tables, etc.
- Design and construct a gymnasium to accommodate full court basketball.
- Design, construct, and equip a 100 person capacity weight training room with lockers, showers, free weights, and total fitness machines.
- Design and construct a forensic training laboratory with ballistics chamber.
- Design and construct a reference library and archive building.
- Design and construct a new warehouse for general storage.
- Renovate 4 barracks (buildings AB, AC, AG, and AF) to accommodate living quarters for 56 instructors.
- Demolish existing (6) Facilities Protection Service (FPS) buildings.

- Construct multi-story dormitories/barracks to house up to 2,800 cadets to bring the total student capacity of the facility to 4,000-4,300 cadets. A common room for relaxation and studying shall be wired for TV and internet service. Women may be expected to attend training, although in smaller numbers than the men, and require separate sleeping and bathroom facilities.
- Construct new billeting to accommodate 150 instructors in single rooms with private bathrooms.
- Construct new driving course – final location within academy grounds to be determined.
- Construct ablution unit near mosque.
- Refurbish and expand existing dog kennels to include new air conditioning units and upgraded electrical service.
- Communications/Command center to accommodate the central radio dispatch, telephone system, and computer operations.
- Communication: radio tower and communications center and administrative offices will have appropriate telephone and internet wiring.
- Site telephone shall be upgraded to allow for telephones in all offices.
- Construct new armory in secure perimeter. Construct armory with magazine area, weapons area, and workshop to accommodate 4 people.
- Construct new billeting to accommodate 150 language instructors in double rooms with private bathrooms.

### **Current Project Design and Specifications**

The TO SOWs included requirements for the contractor to submit the project design and specifications to the government for review and approval. Specifically, TO 06 required 15%, 30%, and 60% submittals; while TO 29 required the submission of 15%, 30%, 60%, and 90% submittals.

The two TOs identified the applicable standards, codes, and regulations. The TOs required the contractor to design and install equipment, materials, and works. In preparing the design, the TOs required the contractor to propose equipment, material, and works that meet the intent of the publications listed below, although the TOs made allowances for the contractor to propose alternatives, provided that documented justification requests for such alternates were submitted and approved by the Sector Program Management Office (SPMO)<sup>5</sup>. TO 06 required the contractor conform to the following standards:

- International Building Code (IBC)
- International Existing Building Code (IEBC)
- International Electro-Technical Committee (IEC)
- International Fire Code (IFC)
- International Plumbing Code (IPC)
- American Society for Testing and Materials (ASTM)
- American Concrete Institute (ACI)
- International Mechanical Code (IMC)

---

<sup>5</sup> The Sector Program Management Office was the predecessor to the Sector Project and Contracting Office.

TO 29 required the contractor conform to the following standards:

- IBC
- IFC
- IPC
- ASTM
- IMC
- International Electromechanical Commission
- National Fire Protection Agency
- Sheet Metal and Air Conditioning Contractor's National Society
- Underwriter's Laboratories
- American Society of Mechanical Engineers (ASME)
- American Society of Heating, Refrigerating, and Air Conditioning Engineers Standard 52 (ASHRAE 52)

Other design related deliverables required by each SOW included an all site survey, surveying, geotechnical investigations, designs with calculations, Computer-Aided Design and Drafting (CADD) drawings, and as-built drawings.

In addition, both TO SOWs stated that it was the intent of the "PMO<sup>6</sup>, in conjunction with the Contracting Officer, to negotiate a firm-fixed-price for this task order after completion of the initial assessment for renovation and 30% design for new construction."

## **Items Removed from the SOW of Task Orders**

According to the Project and Contracting Office (PCO) project manager, Parsons had completed 100% of the project requirements at the time of their termination with the exception of warranty work by the subcontractor. However, in order to consider the BPC project 100% complete, the PCO had to remove from the SOW (de-scope) major portions of both TOs. According to PCO and the Multinational Security Transition Command-Iraq (MNSTC-I) representatives, "schedule and cost ailments" were the factors in de-scoping 24 items from the TOs. For a complete list of the de-scoped task order items, please see Appendix C. At the time of the de-scoping, the project was almost a full year behind its original completion date of July 2005.

## **Site Assessment**

On 22 August 2006, 4 September 2006, 21 September 2006, 10 November 2006, 1 December 2006, and 8 December 2006, we performed on-site assessments of the BPC project. We were accompanied on our on-site visits by BPC personnel, the USACE Gulf Region Central (GRC) Commander, the PCO project manager, and/or Multi National Security Transition Command – Iraq (MNSTC-I) personnel.

During the initial site visit, we identified significant plumbing issues within the cadet barracks' buildings<sup>7</sup>. We performed follow-up site visits to assess the remainder of the BPC project and also to determine if appropriate corrective actions were taken for the

---

<sup>6</sup> PMO refers to the Program Management Office, which was the predecessor to the Project and Contracting Office.

<sup>7</sup> See SIGIR report, PA-06-078.1 & 079.1, "Quick Reaction Report on the Baghdad Police College, Baghdad, Iraq," 27 September 2006.

plumbing issues initially identified and the other construction deficiencies subsequently identified.

As a standard part of our assessment, we reviewed the design submittal process, the adequacy of the design submittals, construction workmanship, and the quality of oversight by the contractor and the government.

We identified the following significant issues with the BPC project:

- A design and specification review process for construction, equipment, and parts with approval/rejection/resubmission and acceptance of documentation was not implemented.
- Poor quality and non standard construction methods, which were not in compliance with required codes, were used.
- Use of low quality parts.
- Improper use of Beneficial Occupancy forms.
- Poor quality management program.
- Lack of contractor invoice review.
- Questionable contractor test results and as-built drawings.

The Site Assessment section will deal specifically with the significant issues; individual appendices will document the work completed, work partially completed/de-scoped, and work completed after our original site visit.

## **Design and Specification Review Process**

Prior to our site visits to the BPC, we reviewed the contractor's design submittals and the government's review and responses. Both TOs required the submission of 15%, 30%, and 60% designs; while TO 29 also required the submission of 90% engineering design documents for review and approval by the government's engineers.

According to the contract's SOW, design reviews are required to determine the quality of the design; incorporation of value engineering opportunities; systems integration; meeting of operational and functional objectives; maintenance of costs within the budget; constructability; cost effectiveness; and final compliance of construction documents with design criteria and relevant codes. In addition, "construction cannot proceed without approval by the SPMO of all construction documents." However, the PCO did not have a submittal process in place to review Parsons' designs.

The initial TO for the project was awarded in May 2004 and construction began in July 2004. The need for a submittal process was initially discussed in a 13 September 2004 meeting between PCO and Parsons. A government representative asked if there was a "...standardized approval format process for designs." The Parsons' representative stated "...that 'submittals' must be 'submitted' ..., i.e., there must be a process in place." A PCO representative replied that "...S&J [Security and Justice] is working on a standardized approval process." The PCO representative also stated that he was "...concerned the drawings are not accurate." The Parsons' representative replied that it was the "...risk Parsons is willing to take to expedite having the work begin." However, since a design build/cost plus contract vehicle was used by PCO for this project, the "risk" Parsons was willing to take automatically transferred to the



government. Consequently, adequate design drawings were needed prior to major construction activities beginning at the site.

We reviewed all of the available Parsons' design submittals and government reviews for both TOs. The PCO subcontracted the review of design submittals to Berger/URS JV. Parsons provided 23 of the 34 required 30% design drawings and 13 of the 34 required 60% design drawings to the PCO for review. However, the Berger representative only reviewed 6 design drawings for both the 30% and 60% submittals. In general, the Berger reviewer determined Parsons' design submittals at the 60% mark to be inadequate. For example, the reviewer found the 60% complete submission for the motor pool, warehouse, library, and contractor workshop to be incomplete because of several electrical issues, such as the "...details of electrical distribution including conceptual single line diagram are not provided..."

While the 60% design submittals were being evaluated as incomplete, construction work was still on-going at the BPC. In a 10 January 2005 meeting between Parsons and PCO representatives, the BPC was listed at "28% complete." However, during the same meeting a PCO representative "questioned the 60% design review for the warehouse, motor pool, and gas station." Also on 10 January 2005, the government reviewer commented that the electrical drawings for the motor pool were not complete.

TO 29 required 90% submittal design drawings and 5 drawings were reviewed. The reviewer concluded that the drawings were "not acceptable as 90% submittal as these drawings are incomplete, inaccurate, and substandard." Further, for the Specifications and Civil Drawings 90% submission, the reviewer stated the following:

*"Drawings submitted are incomplete and lack information for the implementation of the project. They are more like 30 to 40% complete and are no way near 90% complete. Details are incomplete and legends/symbols do not match. No profiles have been drawn for the water and sewer lines. Critical dimensions have not been shown or indicated. Drawings do not identify their purpose. They do not identify new from existing work. We are therefore rejecting this entire submittal. Please revise and resubmit."*

The contractor submitted 100% complete designs to the PCO. This design was reviewed by Berger on 23 April 2005 and was rejected with the following comment for the electrical section for the motor pool and ablution unit buildings:

*"This Submittal is rejected as 100% complete, because:*

- *The submittal is partial because **only diagrammatic** grounding system, single line diagram and fire alarm drawings are submitted. The lighting system, Power, Data/Communication System, Fire Alarm System, Distribution, Site Plan, External Lighting System etc drawings are not included in 100% Submittal!!!!*
- *Full compliance with our electrical review comments made on 60% Submittal is required. A written confirmation of compliance shall be forwarded with real 100% submittal.*
- *It is stated on drawings that these are **diagrammatic drawings** which can not be accepted as 100% Submittal."*

The fuel station, range toilet, contractor workshop, instructors' accommodation, language instructors' accommodation, and library buildings design submittals received the comment that the electrical submittal was "not 100% complete."

Further, on 19 June 2005, the Electrical Infrastructure 100% complete submission was critiqued as being "incomplete, inaccurate and substandard." In addition, it was also mentioned that "Parsons made direct 100% submittal without submitting 30% and 60% submittals as required by the project scope of work."

There is no indication that the contractor ever updated the 100% design drawings with the reviewer's comments and resubmitted them to the PCO for review.

A submittal log was needed to document and track the following information:

- number of design and product/equipment submittals
- date of original submittal
- type of submittal
- description of submittal
- name of government representative assigned/reviewing the design submittals
- approval/Rejection of submittal with comments and notes
- status (if previously rejected)
- corrective actions were addressed from the rejected submittals
- final approval and acceptance of submittal

As a result, construction continued from July 2004 through June 2005 even though the contractor had not provided the required number of complete design drawing submissions. Further, when drawings were submitted, they were largely rejected by the PCO for being incomplete, inaccurate, and substandard.

Finally, in at least one case, the government reviewer did not thoroughly review the design submittals. For example, TO 06 required the construction of a dining facility with an attached kitchen. The 60% and as-built drawings do not have a kitchen attached to the dining facility. In fact, there is no kitchen in either the 60% or the as-built drawings, and the government reviewer did not comment on the omission of this fact.

To date, the PCO stated Parsons has not provided satisfactory as-built drawings. For example, for the motor pool building, the "as-built drawing for sewer and drainage systems is not according to the existing conditions of the toilet and bathroom facility;" while for the exterior water supply networks, the "as-built drawings provided for water distribution do not match the existing field conditions in terms of location, construction and materials." Even though Parsons was terminated in May 2006, PCO representatives stated they are still negotiating with Parsons for accurate and complete as-built drawings.

While the government's reviews generally identified poor electrical design drawings by the contractor, there was no mention about the absence of quality, detailed design construction drawings. It is customary to show construction detail for individual items as well as typical details for items or components used at multiple locations. All construction detail shows the material, method, and critical dimensions to perform the task for the benefit of the installer. The contractor's drawings lacked significant and basic design details, such as the rough-in and finish-out for the installation of plumbing fixtures (a riser diagram for both fresh water and soil piping) and the need for an

adequate number of cleanouts and traps. Further, there was a significant omission with regards to the location and correct type of building expansion joints.

Detailed design drawings for the rough-in and finish-out of the plumbing fixtures were not provided by the contractor. Instead the drawings were generic and did not specify the distance that the hot and cold water lines should extend beyond the wall (i.e. rough-in) for the plumber to connect to the shower faucet and head (Figure 1). In addition, the drawings do not provide an enlargement of one shower as an example to provide specific installation details, such as the type of plumbing fixtures to use (i.e. finish-out). Without detailed design drawings, the subcontractor does not have adequate guidance to properly install the water lines and plumbing fixtures.

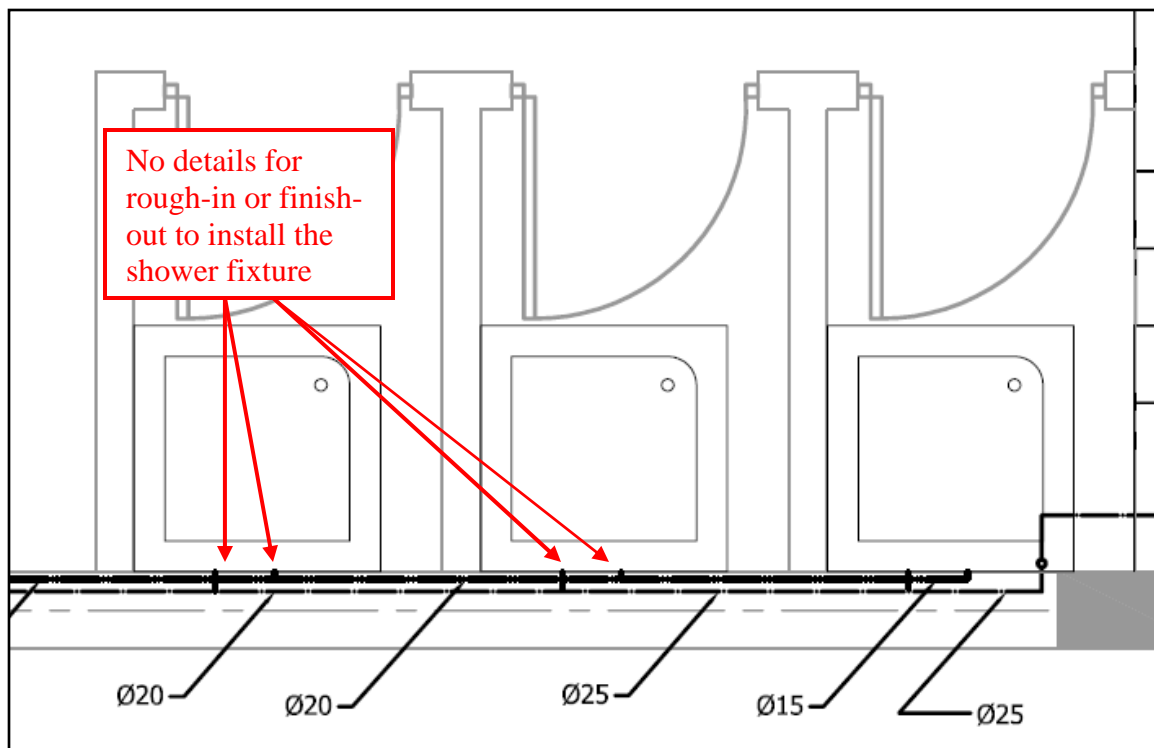


Figure 1. Contractor design for installation of hot and cold water lines for cadet barracks showers

### Cleanouts

Section 708 of the IPC requires the use of cleanouts. A cleanout is a soil (wastewater) pipe fitting and associated piping connected to a building sewer or lateral sewer line. Cleanouts provide access to the soil pipe to unlog and/or remove substance preventing the flow. This feature for soil pipe facilitates normal maintenance and diagnosis of problems and helps to prevent extensive and unwarranted repair. According to IPC Section 708.3.5, cleanouts “shall be installed at each change of direction of the building drain or horizontal waste or soil lines greater than 45 degrees.”

The contractor did not provide the required cleanouts for soil pipe at multiple locations of the cadet barracks. For example, each toilet and shower required the use of a cleanout since the drains connected to the sewer lines at a change in direction. In addition, there are no traps installed for the shower soil pipes. Without the required cleanout traps installed for the toilets and for the directional change of the

soil pipes, solid waste collects and will ultimately clog the soil pipes, resulting in a backup of waste water and a release of sewer gas (commonly referred to as methane gas). As a result of not complying with the IPC requirement, the BPC will be faced with a continual maintenance problem, including the backup and overflow of waste water onto the floor. This continual maintenance problem will present the BPC with the challenge of housing its cadets in barracks where the plumbing is frequently backed up.

The as-built drawings for the cadet barracks indicate cleanouts were only used at the far end of a straight run of soil pipe, not for every toilet trap and change of direction (Figure 2). The government engineers reviewing the cadet barracks design drawings failed to detect and identify the lack of a sufficient number of cleanouts and traps at the correct locations. As a result, not only did the contractor not follow the specific code requirement, which is compounded by the contractor's poor plumbing installation and construction, but the likelihood of the sewer lines backing up increased significantly, even under normal use.

In addition, on the as-built drawings for the "typical floor drainage" cadet barracks design, the listed design references were the Practical Plumbing Design Guide, National Plumbing Code, and Plumbing Engineering Services Design Guide – The Institute of Plumbing; however; there is no reference to the standards required by the TO – the IPC. Compliance with IPC criteria for design, construction, and installation was required by the TO.

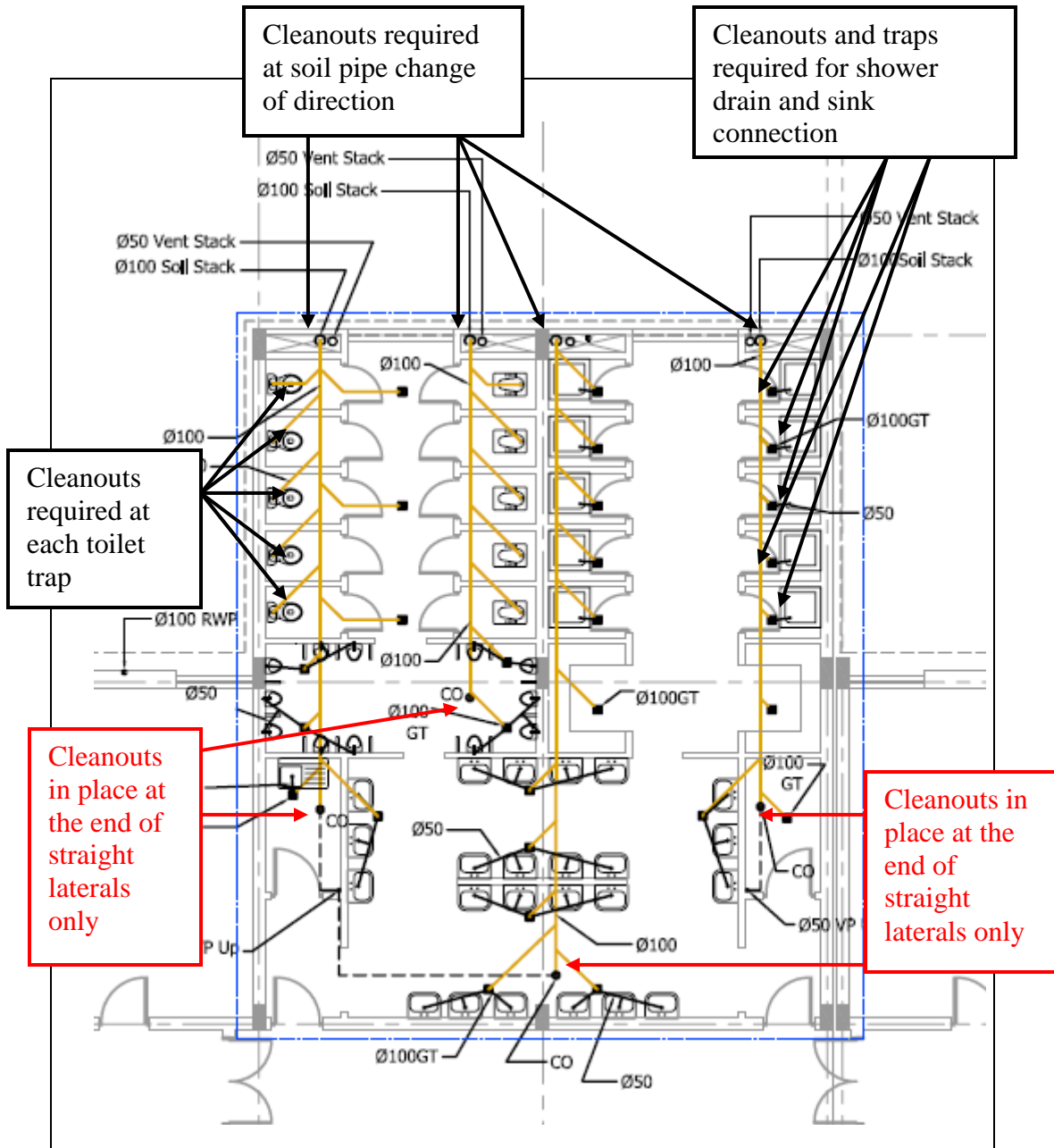


Figure 2. Floor plan and soil pipe detail for a typical cadet barracks facility

### **Building Expansion Joint**

The 60% design drawings for the instructors' barracks did not include any specific details for the use and installation of expansion joints; instead there are only vague references to the expansion joints in the design drawings (Figure 3). The government engineer's design reviews did not identify the obvious absence of this item on the design drawings and subsequently did not require the contractor to resubmit the drawings with exact expansion joint details. Specific expansion joint details are critical, since properly designed and correctly installed joint systems are capable of protecting buildings and structures from damage caused by thermal expansion and contraction as well as anticipated foundation movements.

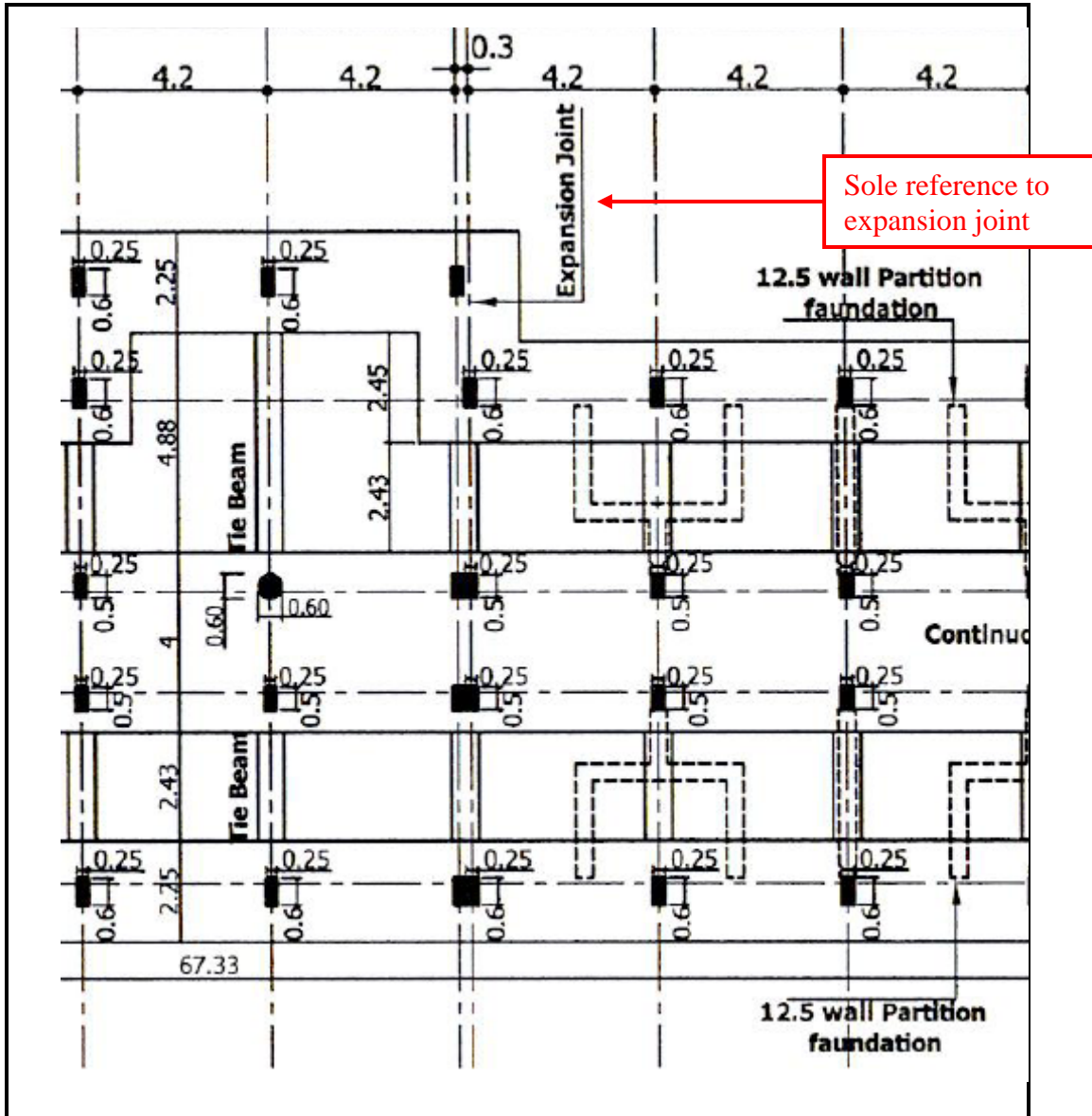


Figure 3. Contractor's 60% design drawings with vague reference to expansion joint

### Quality of Construction

During our site visits, we identified significant areas of poor quality construction workmanship by the contractor. The deficiencies will be addressed briefly in this section; for a full description of each building/facility inspected during our site visits, please see Appendix D-Work Completed, Appendix E-Work In Process/Work Partially Completed, Appendix F-Systemic Problems with BPC Buildings, and Appendix G-Work Completed Since Initial Site Visit.

#### Cadet Barracks

For the cadet barracks, we identified poor plumbing installation, concrete segregation and honeycombing, and reinforcement bar exposure. Site Photo 3 shows the typical plumbing pipes used throughout the cadet barracks. According to GRD's own assessment, this plumbing practice was described as "abnormal fittings

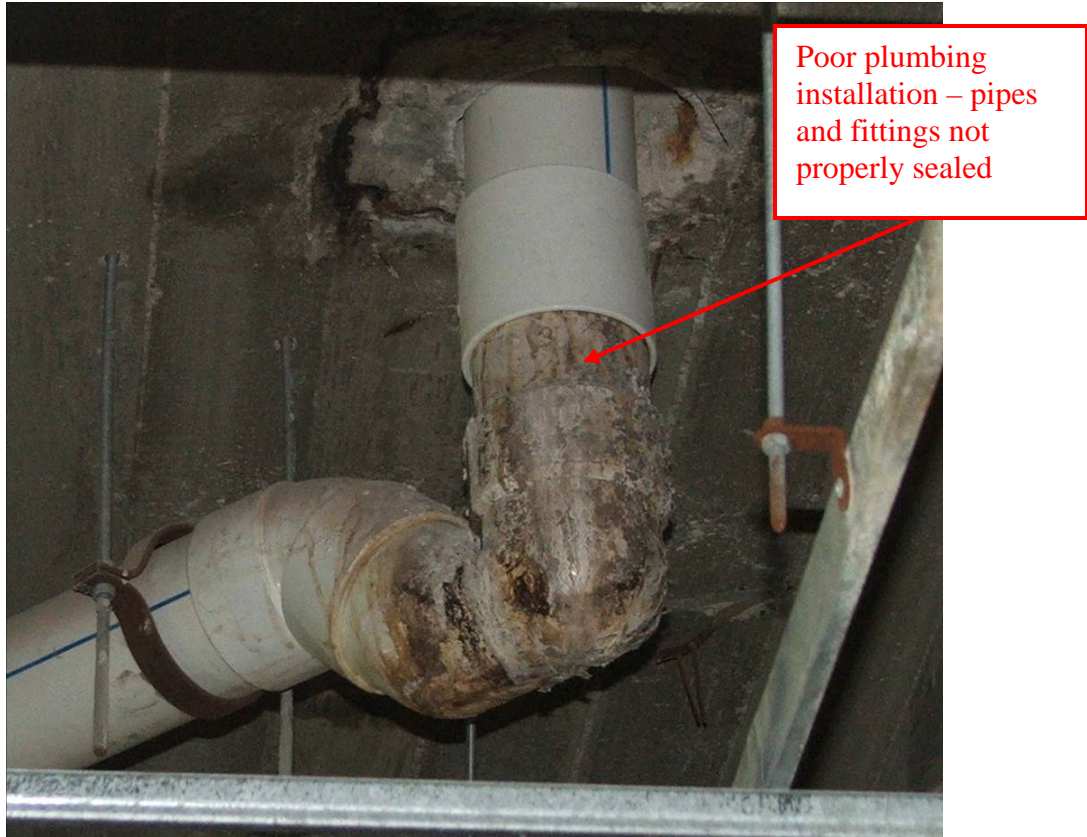
connected by drilling holes in polyvinyl chloride (PVC) pipes and connecting them with another pipe is not an acceptable method of construction.”

Site Photo 4 provides an example of another plumbing installation problem - improper sealing; while Site Photos 5, 6, and 7 provide examples of concrete segregation and honeycombing, and reinforcement bar exposure. In addition, the contractor did not comply with IPC code Sections 707 and 708, which specifically prohibits the use of cement or concrete joints and required the use of cleanouts for soil pipe lines greater than 45 degrees, respectively.

PVC pipe with hole drilled and connected with another pipe



**Site Photo 3. Typical cadet barracks plumbing fixture**



Poor plumbing installation – pipes and fittings not properly sealed

**Site Photo 4. Improper pipe sealing in cadet barracks**



Reinforcement bar exposure

**Site Photo 5. Reinforcement bar exposure in cadet barracks**





**Site Photo 6. Concrete segregation and honeycombing in cadet barracks**

Honeycombing and segregation



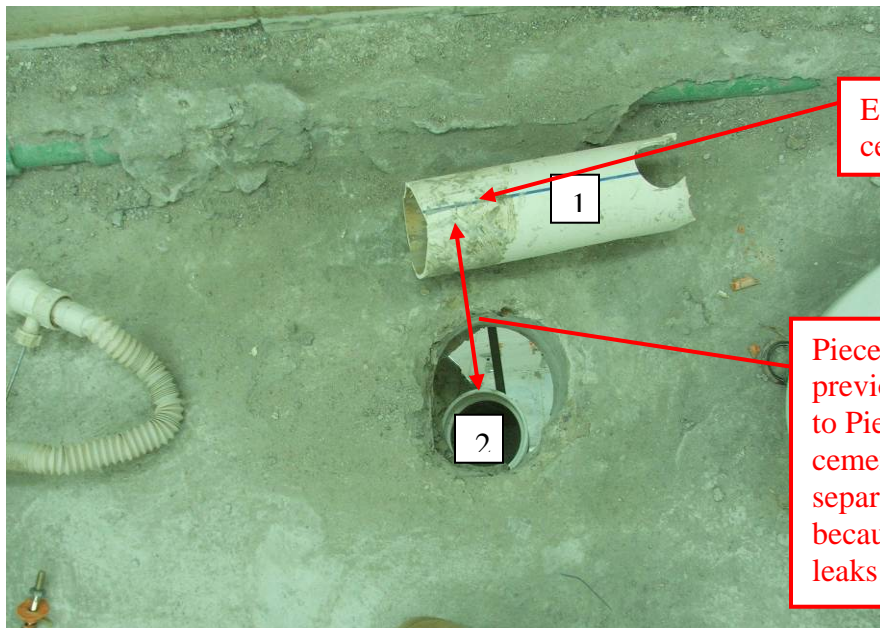
**Site Photo 7. Concrete segregation and honeycombing**

According to the USACE Gulf Region Division (GRD) and BPC representatives, the common practice of local subcontractors is to cement joints in the bathroom areas (Site Photos 8 and 9); however, this practice is strictly prohibited by the IPC. In an earlier section of this report, we mentioned the lack of the required number of cleanouts in the design drawings. Site Photo 10 shows no cleanouts for several traps and 90 degree turns. Not only is a cleanout required by the IPC, without it solid waste will collect and ultimately clog the pipe.



Evidence of failed cemented joints

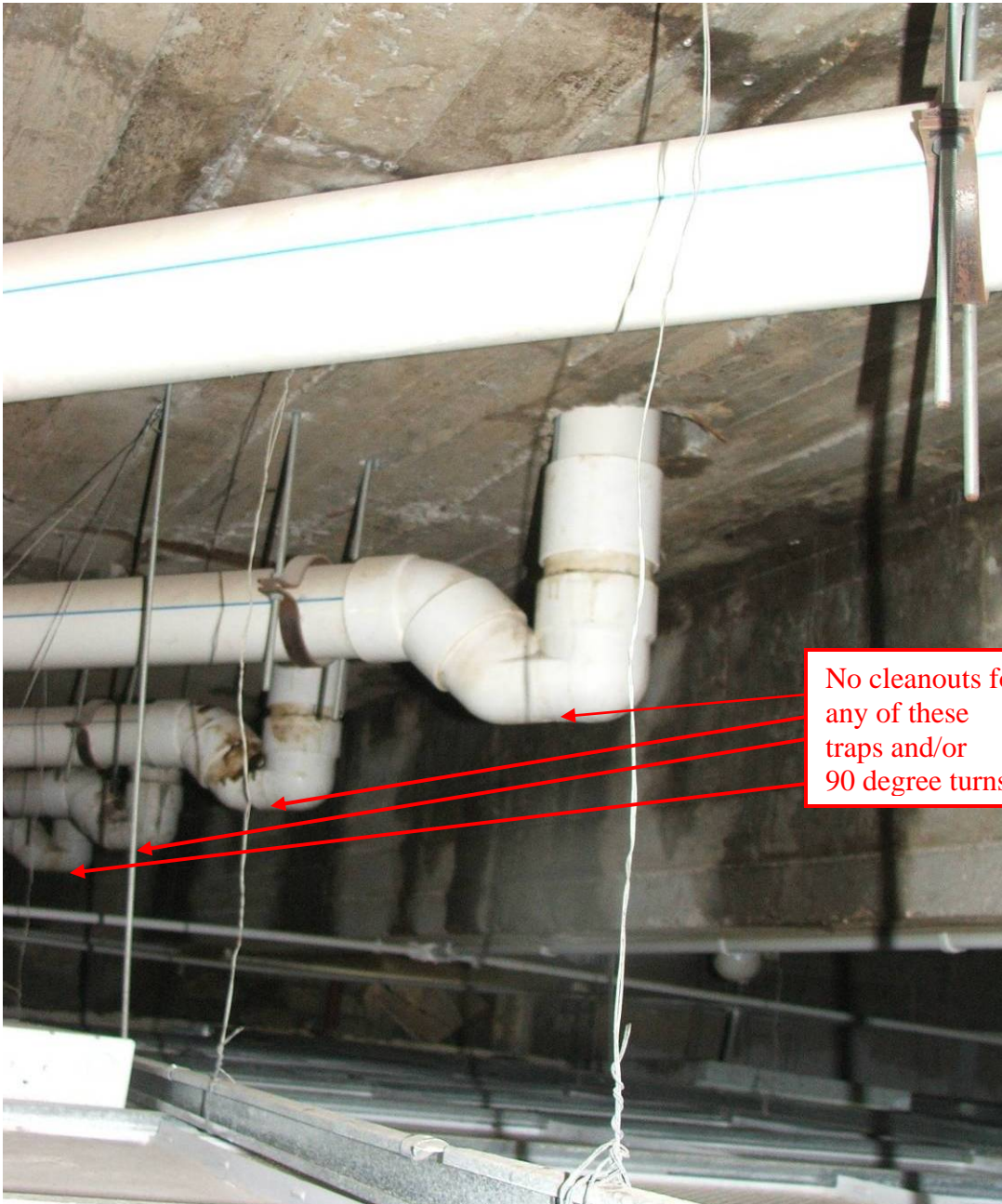
Site Photo 8. Piece of original plumbing pipe removed from cadet barracks



Evidence of cemented joints

Piece 1 was previously connected to Piece 2 with cement. Piece 1 was separated from Piece 2 because of water leaks.

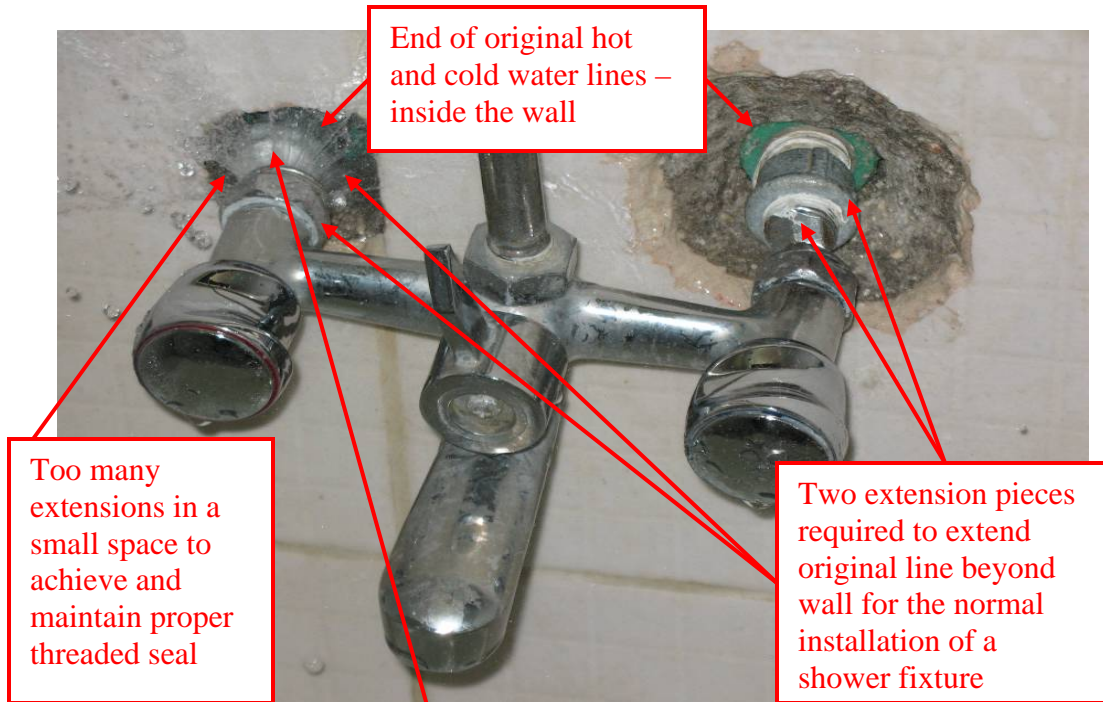
Site Photo 9. Existing pieces of plumbing pipes in process of being removed



**Site Photo 10. View of plumbing for first floor toilets**

With regard to plumbing within the cadet barracks, we also identified poor installation of the shower fixtures. For example, the hot and cold water lines were not extended beyond the wall, which resulted in an additional extension needed to bring it beyond the wall prior to connecting to the fixture. Site Photo 11 shows the end of the original cold water line, which is at least one to two inches inside the wall. The wall had to be chiseled into to add the extension pieces. When the original cold water line is not extended beyond the wall, the extension piece must be adequately sealed to prevent water leaking behind the wall. This installation technique provides an increased opportunity for leaks between the plumbing fixture, the extension piece, and the original cold water line, which ultimately increases the probability of leaks behind the wall. During our site visit on 8 December 2006, we identified a leak on

the ground floor (Site Photo 12). A third floor plumbing fixture was leaking and apparently was not correctly installed and sealed to the wall, which consequently allowed water to flow down to the ground floor.



Site Photo 11. Leaking shower fixture in cadet barracks

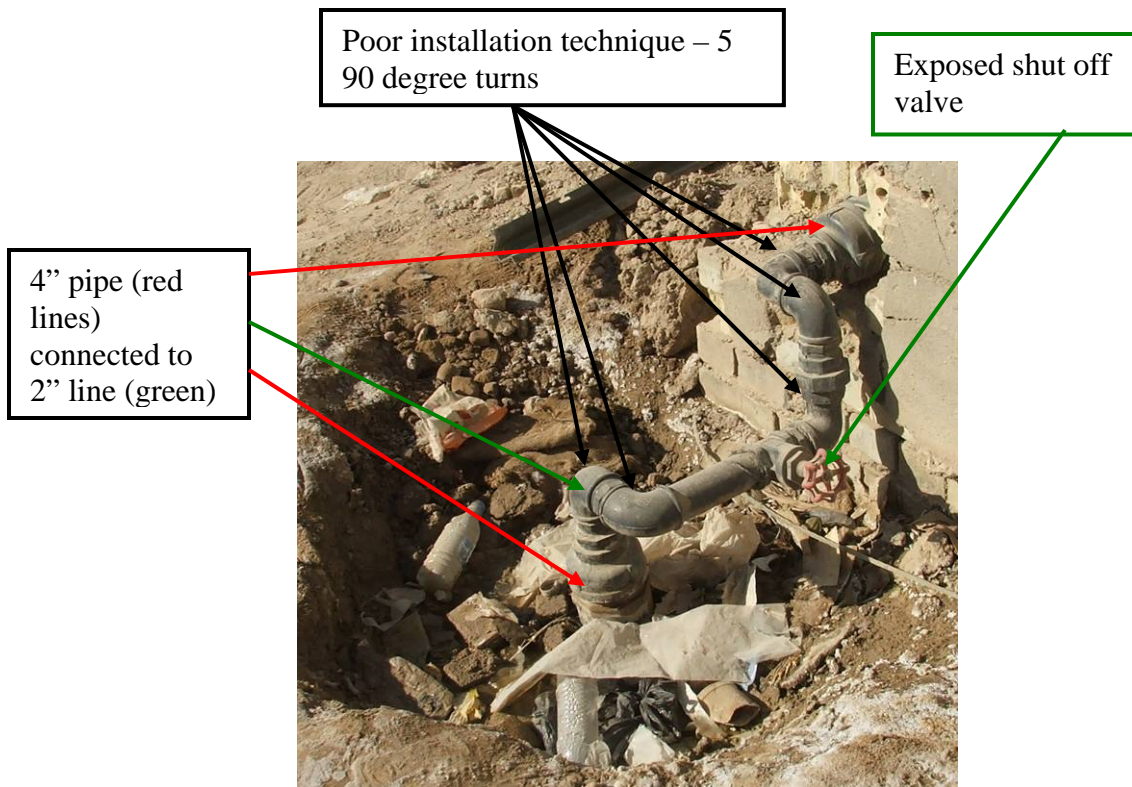


Site Photo 12. Water damage on ground floor from leak on 2<sup>nd</sup> floor

### **Instructors' Barracks**

In the instructors' barracks we identified a poorly installed main water line connection, tar damage in the bathrooms, which leaked from the roof down to the ground floor, and a poorly installed electrical outlet (Site Photos 13-16). The main water line connection is peculiar since multiple sized pipes are used. Specifically, there is a reduction from the 4" main pipe to a 2" pipe and then expanding to a 4" pipe.

More importantly, we discovered significant expansion cracks on the exterior and interior of the buildings (Site Photos 17-20). We determined that the contractor's as-built drawings (Figure 4) do not reflect the reality of what was actually constructed at the instructors' barracks.



Site Photo 13. Installed main water line to instructors' barracks



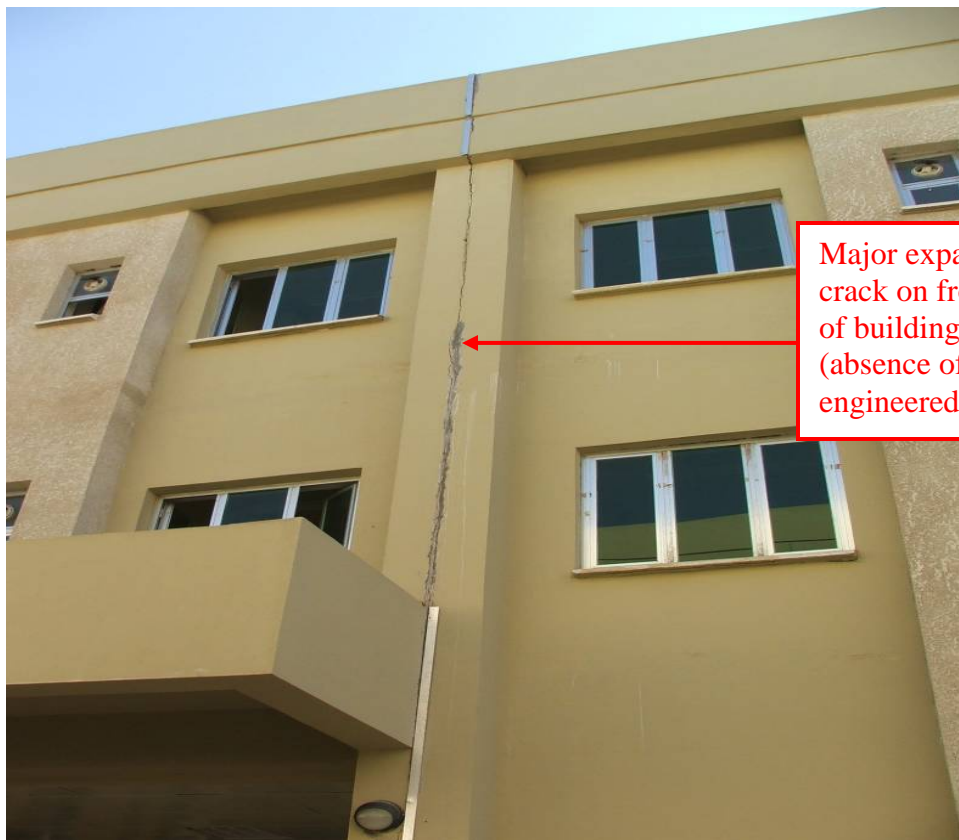
Site Photo 14. Tar leaking from roof to ground bathroom.



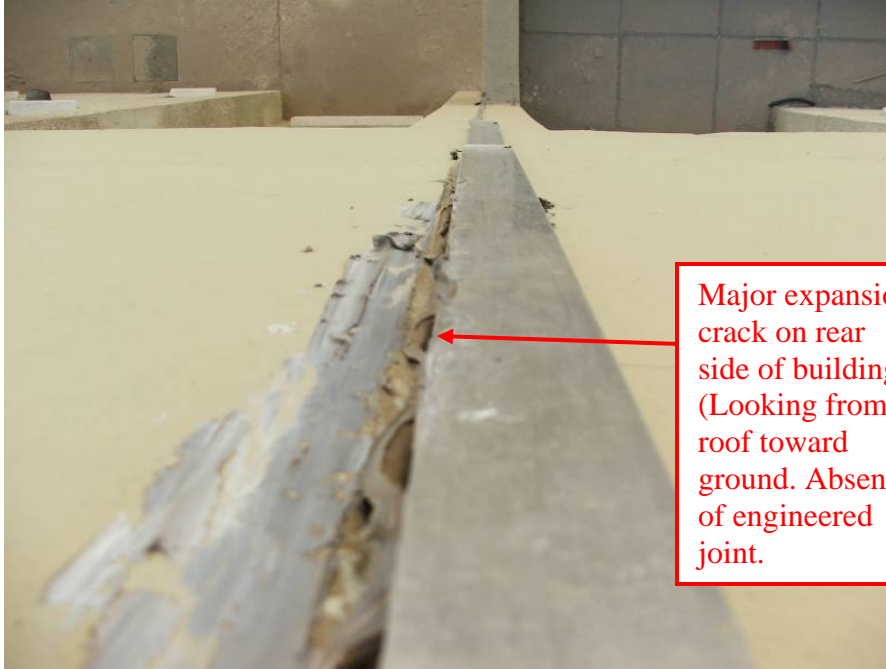
Site Photo 15. Close-up view of tar damage



**Site Photo 16. Unusable electrical outlet - mortar and paint inside the outlet**



**Site Photo 17. Exterior expansion crack on the instructors' barracks**



Site Photo 18. Exterior expansion crack on rear side of instructors' barracks

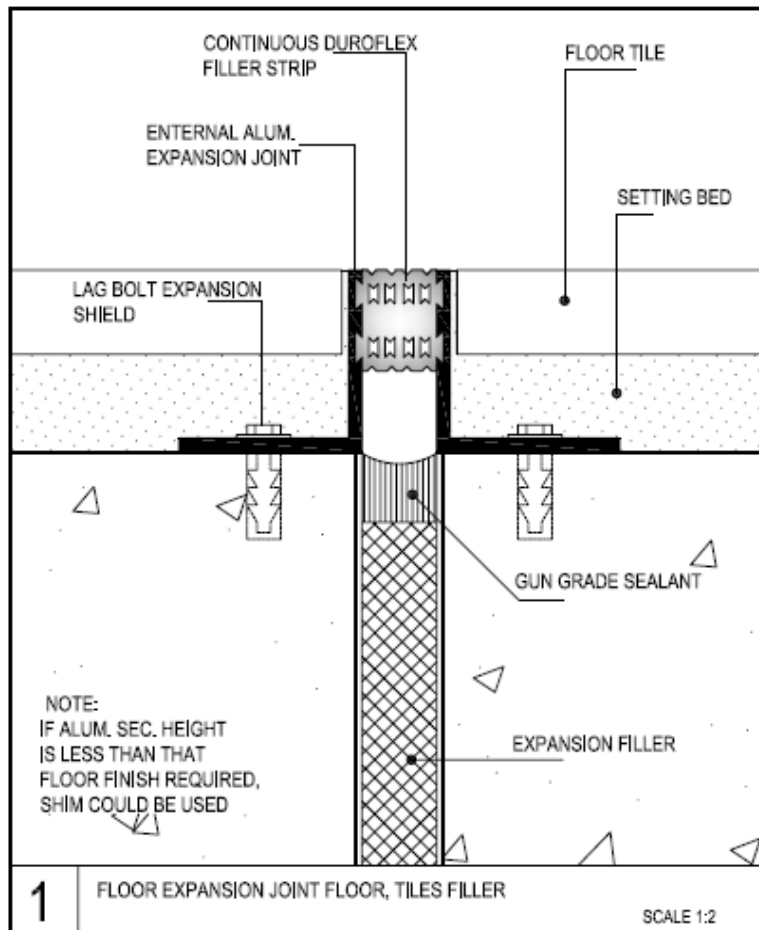
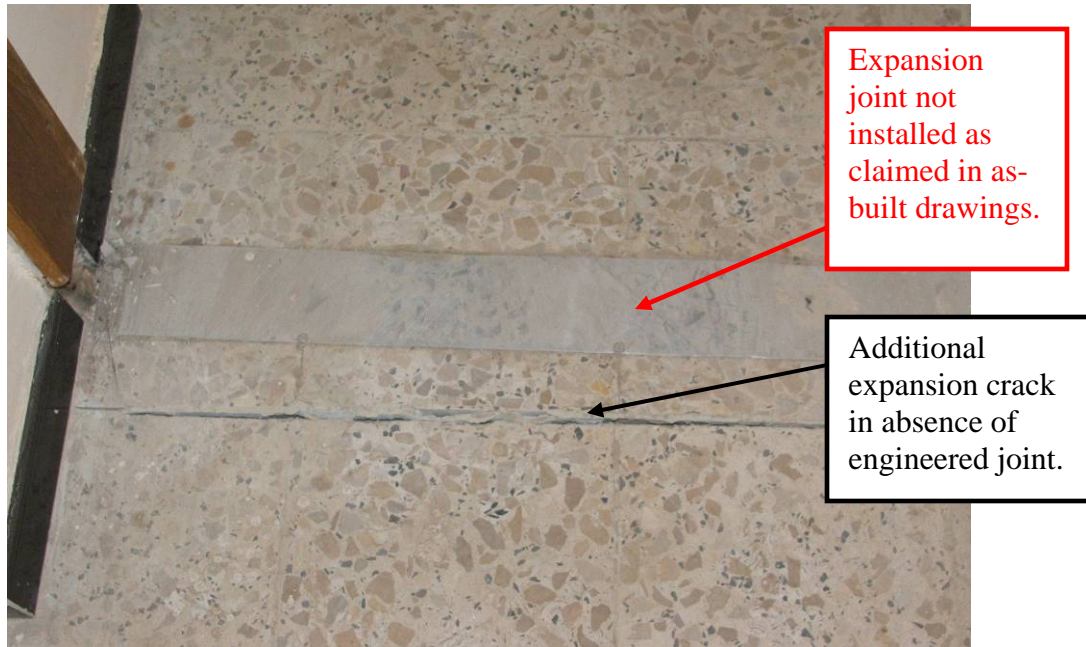


Figure 4. Contractor's as-built drawing for floor expansion joint



**Site Photo 19. Interior expansion crack in instructors' barracks**



**Site Photo 20. Interior expansion crack inside the instructors' barracks**

### **Central Laundry Facility**

During our site visit, we identified the following deficiencies:

- Areas of severe reinforcement bar exposure on the surface of the load-bearing reinforced concrete ceiling beams (Site Photos 21-23)
- Areas of severe concrete segregation and honeycombing (Site Photos 24-26)
- Poor quality brick workmanship (Site Photo 27)



A notice to proceed for the central laundry facility was granted on 1 February 2005, with a contracted completion date of 15 August 2005. According to GRD documentation, on 23 October 2005, the Parsons' site engineer discovered concrete deficiencies. Specifically, there was "evidence of several construction deficiencies, including lack of consolidation, 'honeycombing,' inadequate concrete coverage of reinforcing steel, and improperly placed electrical conduit." Parsons notified the USACE GRD on 24 October 2005 of its concerns with the central laundry facility. Parsons' concerns included:

- Inadequate concrete cover for reinforcing steel and embedded electrical conduit "potentially lends to spalling (chipping, fracturing or fragmentation), de-lamination and reinforcing steel corrosion, which ultimately could cause structural failure."
- Inadequate concrete cover for reinforcing steel may "create a condition in which the reinforcing steel is subject to corrosive action from the humidity and chemical-use associated with laundry facility operations. Potential corrosion of the re-steel may lead to slab inability to bear roof load and eventual structural failure."

Parsons initiated two independent analyses to determine the course of action. According to GRD documentation, the results of the analyses concluded the deficiencies "may be corrected through repair techniques." In addition, the subcontractor "indicated their acceptance of contractual liability and confirmed responsibility to conduct repair and/or replacement as directed." The document continued with the following:

*"...subcontractor agreed that they would take financial responsibility for the engineering fix, but insisted that we allow them to load test the facility and determine whether complete or partial demolition is required. Once the tests are completed, the results would indicate 'pass' or 'fail' and the engineering solutions identified herein can be implemented. We are of the opinion that the tests will result in a failure mode, but should be done in order to minimize financial costs to the US Government."*

Two options were identified to potentially correct the structural deficiencies:

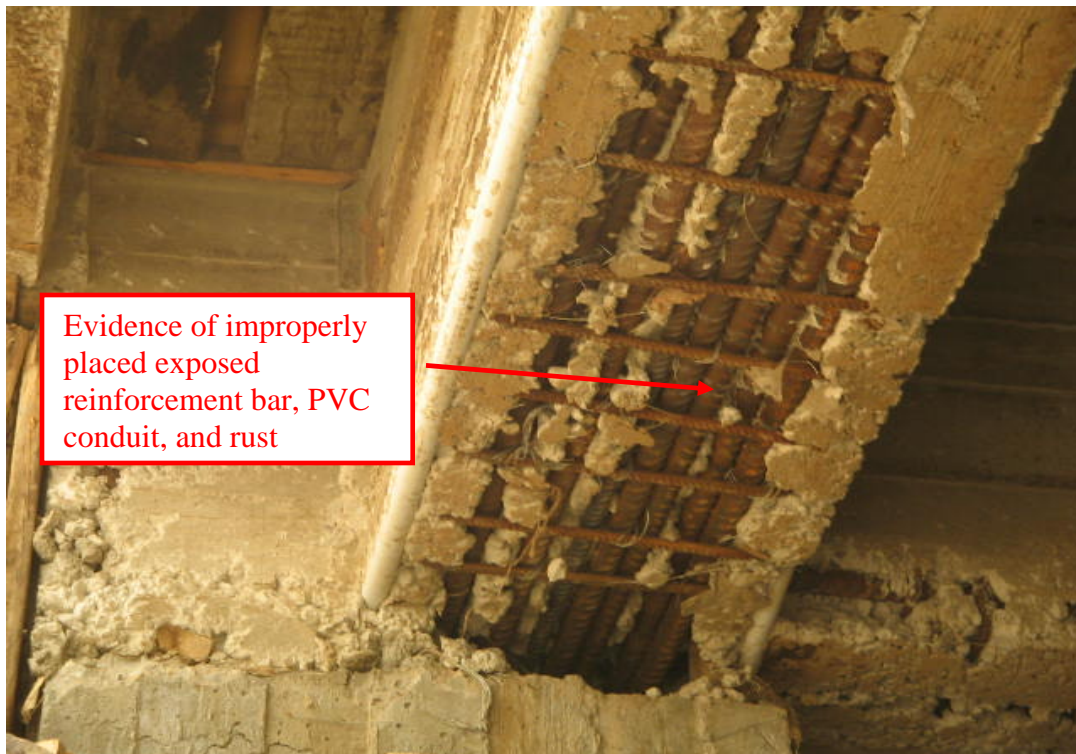
- Remove the existing concrete slab, performing the column and beam repairs, preparing the forms, and completing the elevated concrete placement.
- Consider a new truss design.

Parsons estimated that the costs to implement Option 1 would be "borne by the subcontractor provided the load tests results were negative. The subcontractor will incur increased costs for demolition of beams/slabs and new construction which are estimated to be about \$250,000 (at no increased cost to Parsons or the government). The cost impact for Option 2 is considered the same as under Option 1 assuming the load tests are negative."

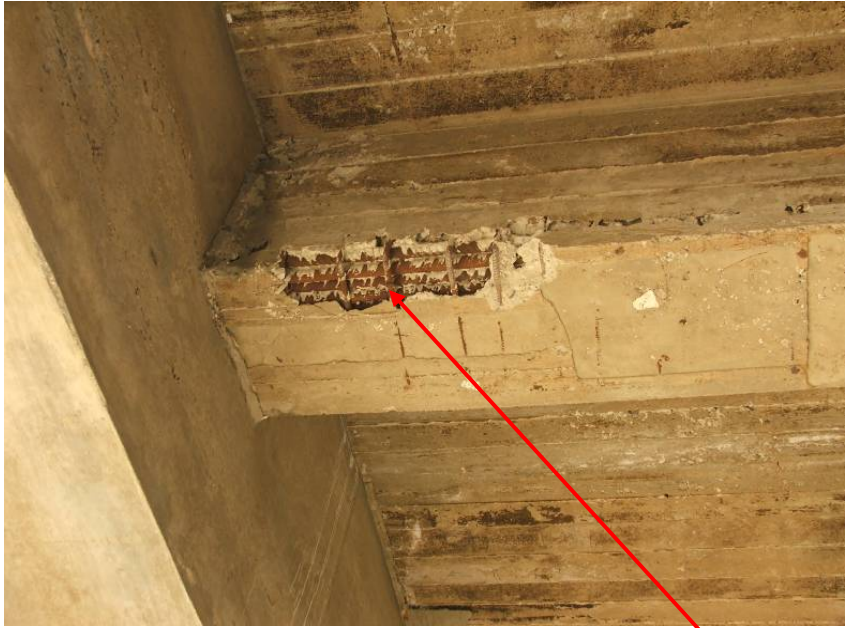
According to GRD representatives, a potential resolution to the problem was agreed to; however, the fix would cost too much money and take too long to complete, so the central laundry facility was de-scoped. Inexplicably, GRD did not pursue the recovery of costs incurred for the partially completed central laundry facility, even though the subcontractor accepted responsibility for the poor construction. GRD did not seek the return of \$348,332 paid to Parsons for this structure.

In addition, since a fix was potentially possible, GRD representatives did not consider the partially built central laundry facility an “imminent danger” to the BPC occupants; consequently, GRD stated that they cannot direct the subcontractor to demolish the building without incurring a cost against the government. However, internal documents indicated that this resolution was not agreed upon by GRD. That is, a response to the proposed retrofit of the central laundry facility stated “in summary, the proposed retrofit for the Central Laundry is not acceptable for structural, constructability, and safety reasons.” In addition, Parsons, in December 2006, stated the subcontractor “made no valid effort to rectify the deficiencies in an acceptable manner and have left a facility that is structurally unsafe and as a result must be demolished.”

Finally MNSTC-I, in order to have a laundry facility for the BPC cadets and instructors, funded its own laundry facility, which is currently under construction and should be completed by December 2006. However, because BPC representatives are concerned about the structural integrity of the existing central laundry facility “shell” and the potential for injury to BPC cadets and instructors, MNSTC-I will pay its contractor approximately \$100,000 to demolish the facility shell.

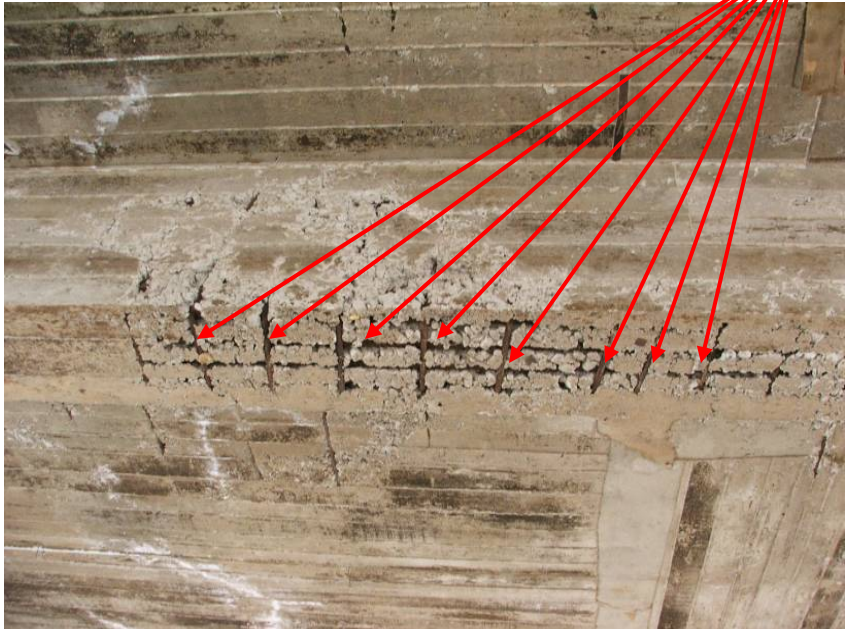


Site Photo 21. Evidence of improperly placed exposed reinforcement bar, PVC conduit, and rust



**Site Photo 22. Reinforcement bar exposure**

Areas of severe reinforcement bar exposure

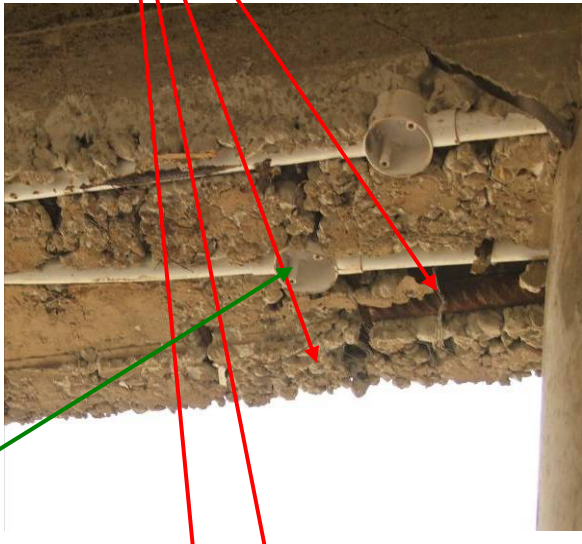


**Site Photo 23. Example of reinforcement bar exposure**

Areas of honeycombing, voids, and segregation



Site Photo 24. Concrete segregation and electrical conduit exposure

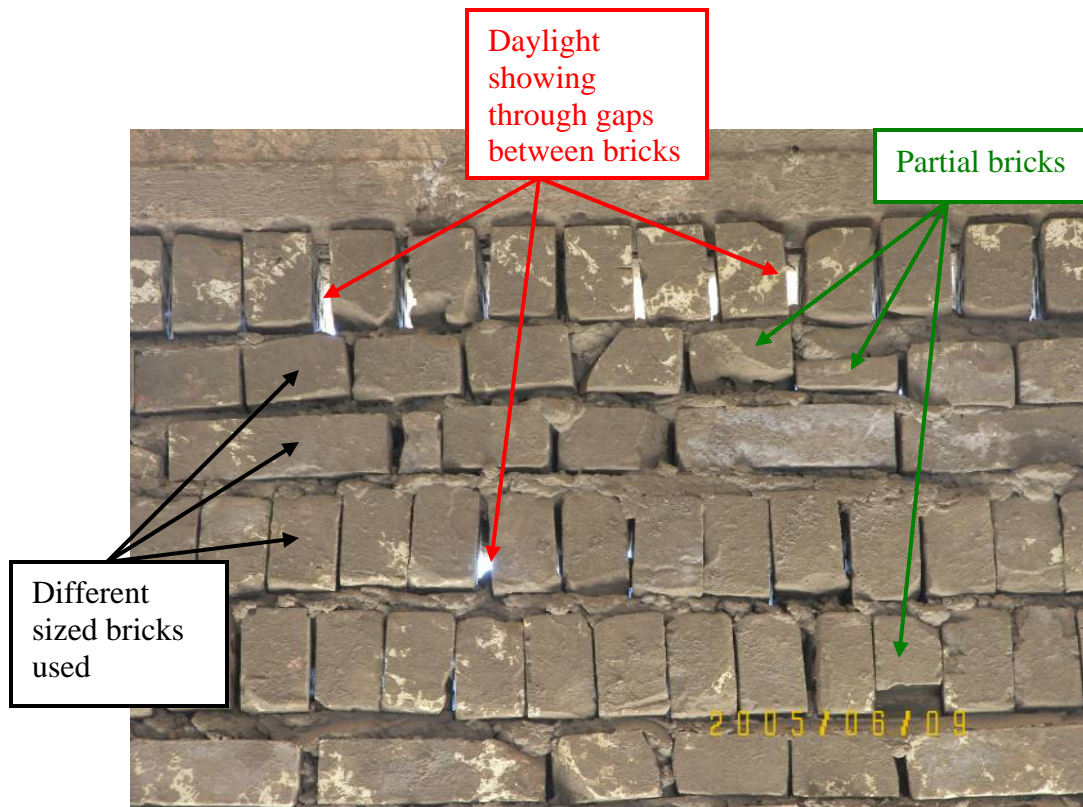


Site Photo 25. Concrete segregation and electrical conduit exposure

Electrical conduit exposure due to incorrect placement



Site Photo 26. Concrete voids and electrical conduit exposure



Site Photo 27. Poor brick work – not level, gaps between bricks, different sized bricks, and partial pieces of brick used in the central laundry facility

## Quality of Parts

The plumbing fixtures used in the cadet and instructors' barracks bathrooms appeared to be low quality fixtures (shower heads, water supply lines, faucets, drain covers, etc) installed in the showers, wash stations (sinks), urinals, and water closets. Site Photos 28 and 29 show the type of plumbing materials used in the water closets, which included flexible water hoses, plastic supply tanks, and thin wall plastic tubing supplying water from the tank to the toilet. Site Photos 30, 31, and 32 show the shower fixtures, including the shower head, the thin metallic tubing used to supply water to the shower head, and the single clamp used to secure the water pipe to the wall. Over time, the clamp will dislodge from the wall and the shower water pipe will hang unsupported.

During our site visits to the BPC, we witnessed the problems associated with the use of the low quality parts. For instance, the clamps holding the shower water pipe to the wall were dislodged; the thin metallic tubing was bent; multiple sink faucets were pulled from the sink and were leaking (Site Photos 33 and 34); and shower faucets were leaking (Site Photo 35).

GRD representatives stated that there is one shower and water closet for approximately every 25 police cadets within the cadet barracks. Considering the heavy usage that each shower and water closet will receive, the low quality material will pose continual maintenance problems for the BPC. In addition to the inferior quality parts, the non-standard installation methods and non-compliant design of soil pipe will result in a high rate of repair and maintenance by the BPC.



Site Photo 28. Water closet in cadet barracks



Site Photo 29. Enlarged view of Site Photo 28



**Site Photo 30. Shower fixture in cadet barracks**



**Site Photo 31. Close-up view of shower head**



**Site Photo 32. Close-up view of clamp**

Two screws of the clamp holding the shower pipe are driven into cement mortar joint between the tiles will not provide needed strength to keep the pipe in place

Low quality plumbing fixture – easily pulled from the sink



**Site Photo 33. Bathroom sink in cadet barracks**

Low quality plumbing fixtures – failed to stop water flow



**Site Photo 34. Water leak**



**Site Photo 35. Leaking shower faucet in cadet barracks**



## Use of Beneficial Occupancy Form

The GRD representatives used Beneficial Occupancy forms to turn over 42 buildings, 2 lift stations, and a water tank to the BPC for its use. The transfer of the buildings, lift stations, and water tank to the BPC should have been simultaneous with the acceptance of the construction from the contractor. According to USACE Engineering Regulation (ER) 415-345-38, "...only facilities which have been completed according to contract (task order) requirements, or substantially completed with minor deficiencies which will not interfere with the designed use of the facilities, will be accepted from the contractor and transferred to the customer."

The Beneficial Occupancy forms used by GRD stated that the "Prime Contractor (Parsons) is overall responsible for the quality of work and by signature below attests that the construction is in accordance with contract plans and specifications." However, for several facilities, neither Parsons nor the GRD was in a position to accurately know whether the construction was in accordance with contract plans and specifications.

For example, for the ablation unit, the remarks section of the form stated the, "End user cannot use the bldg. There is no connection to sewer and potable water until infrastructure is complete." The contract specifications called for the ablation unit to be tied into the main water supply network and the main sewage network, which according to the Beneficial Occupancy form (and confirmed by our initial site visit) were not connected. Since the ablation unit was not connected to the water supply or sewage networks, it was not possible for the toilets, sinks, water heater, and drains of the building to be tested. It is illogical to think the GRD would transfer a building to the BPC without testing its basic functions (potable water, toilets, sinks, hot water, and drains).

Also, this building required testing of the electrical systems, especially considering that the 100% Electrical Design Drawing submittal for the ablation unit was "rejected" because "the submittal is partial...no compliance with our electrical review comments made on 60% Submittal is made." There is no indication the ablation unit's electrical system was tested prior to the signing of the Beneficial Occupancy form.

In addition, the ablation unit Beneficial Occupancy form, signed 23 May 2006, stated that the "USACE performed a final inspection of facility, Ablution Unit, on 30 October 2005 and any noted deficiencies are on the attached Enclosure 1 (Final Punchlist)." The need to quickly transfer the ablation unit to the BPC is questionable because "until infrastructure is complete," the ablation unit would not be useable by the BPC. The Beneficial Occupancy form also states that "this acceptance does not relieve Parsons of the responsibility of correcting the noted 'Final Punchlist', warranty items, or latent defects that are discovered after the date of this inspection." Since the Beneficial Occupancy form was signed on 23 May 2006 and Parsons was terminated on 31 May 2006, GRD had to contract with another contractor to connect the main water supply and main sewage networks. In November 2006, approximately 7 months after the Beneficial Occupancy form was signed, the ablation unit was finally connected to the main water and sewage networks and is being used.

Of the 46 Beneficial Occupancy forms completed and signed off by the GRD and Parsons representatives, 20 forms included one of the following remarks:

- “we could not operate electrical water heaters and full electrical load test for the whole building because the temporary generator belongs to subcontractor are under capacity of the load.”
- “we could not check the plumbing and sewer system no water available.”
- “could not operate full electrical load test for the building, the temporary generator is under capacity for the load.”
- “we could not operate full electric load because the temporary generator belongs to subcontractor are under capacity of the load.”
- “couldn’t complete water test for all the building because the water pumping was stopped.”
- “I could not operate HVAC (Heating, Ventilation, and Air Conditioning) and electrical water heaters because the small generator besides the building is under capacity.”
- “I could not check the plumbing and sewer system because the water comes out strongly from many water hoses and joints.”
- “The building is not under full electric load.”
- “The building is not connected to infrastructure service, infrastructure is not complete.”
- “The end user can not use the bldg no connections of sewer, potable water pipes and electrical power until infrastructure is completed.”

For classroom building E, a Beneficial Occupancy form was signed on 21 May 2006. A two page punch list was included with the form, and in the Remarks section it stated that the “...major items are completed and the most rest work will be on the roof, so the building could be occupied by cadets tomorrow.” However, one of the punch list items was the “...fire alarm system is not working, its need to be fixed.” GRD and Parsons representatives believed a building without an operating fire alarm system was acceptable for turnover to the BPC and ready for occupancy by the cadets.

For the storage water tank, a Beneficial Occupancy form was signed on 18 May 2006. A one page punch list was included with the form with 9 items in need of attention and the following Note:

*“Per Agreement with Prime Contractor (Parsons), a check of tank integrity must be performed.”*

GRD and Parsons representatives, by signing the Beneficial Occupancy form, verified the storage water tank was constructed in accordance with “contract plans and specifications” even though an integrity check of the tank had not been performed. In addition, one of the 9 items on the punch list included the fact the GRD was not “...able to check for water migration.” Again, this tank was turned over to the BPC without anyone even determining if the tank was properly sealed against leaks and penetration from outside elements.

For barracks building AI, GRD and Parsons representatives signed the Beneficial Occupancy form on 6 June 2006. However, one of the punch list deficiencies listed was

a “...bad smell at male bath due to deficient work of sewage system.” This building was deemed acceptable for habitation even though Parsons’ sewage system work was identified as “deficient.”

Further, for the range administration building, GRD and Parsons representatives signed the Beneficial Occupancy form on 29 May 2006 even though the Remark section of the punch list stated the “...level of the building sewer system is under the level of the academy sewer system.” With the building sewer system lower than the level of the existing academy sewer system, either a pump station will need to be constructed to force the flow to the academy sewer system or the building’s sewer system will have to be redone. We could not determine how GRD and Parsons representatives could sign the Beneficial Occupancy form stating this building’s construction met the “contract plans and specifications.”

For the dog kennel, GRD and Parsons representatives signed the Beneficial Occupancy form on 7 June 2006, with no punch list items noted. GRD records indicated Parsons completed “Emergency Work” for the facility. We identified the work completed by Parsons, which consisted of re-wiring the electrical panel (Site Photo 36). By signing this form, the GRD and Parsons asserted that this electrical work was in accordance with specifications and in compliance with IEC codes.



**Site Photo 36. Electrical panel for the dog kennel**

Interestingly, of the 46 Beneficial Occupancy forms completed and signed off by GRD and Parsons representatives, 30 forms had the punch list comment of “no copies of as-built drawings available.” Without the as-built drawings to refer to, it does not seem possible for GRD or Parsons representatives to legitimately sign off affirming the construction was “in accordance with contract plans and specifications.”

# Quality Management Program

## Contractor's Quality Control Program

Department of the Army ER 1180-1-6, dated 30 September 1995, provides general policy and guidance for establishing quality management procedures in the execution of construction contracts. According to ER 1180-1-6, "...obtaining quality construction is a combined responsibility of the construction contractor and the government."

The contract for the BPC required the contractor to establish and maintain an effective Quality Control (QC) system in compliance with the contract clause title "Inspection of Construction." This required the contractor to maintain an inspection system and perform inspections to ensure that the work performed conformed to contract requirements. The contractor must maintain complete inspection records and make them available to the government. The QC system consists of plans, procedures, and organization necessary to produce end products which comply with the contract requirements.

Parsons developed a QC plan for TOs 06 and 29, which established procedures and practices for effective determination of conformance to the standards of quality for materials, construction procedures, and final design of the TO project specifications. The plan stressed the careful inspection, testing, oversight, and documentation during the entire construction phase. Parsons Quality Control Representatives (QCR) completed a daily QC report for all activities at the site. In addition, preparatory and initial inspection reports, test results, Nonconformance Reports (NCR), and other requested information is to be included.

We reviewed all electronic documentation available from the PCO computer network drive regarding Parsons' QC program. We identified daily QC reports for the months of March 2005 through April 2006, with 4 months having 6 or less daily QC reports. We could not determine if QC reports were completed prior to March 2005 or after April 2006. For the daily QC reports available, the QC representatives monitored field activities. The daily QC reports generally documented daily observations of what occurred at the site, problems encountered at the site that required corrective actions, and potential solutions to correct the problems.

According to Parsons' QC plan, NCRs document:

- Work not meeting the contract specifications or standards
- Deficiencies that cannot be corrected
- Material that fails inspection criteria
- Uncorrected deficiencies that are permanently incorporated into the final product
- Items that do not meet the submittal criteria
- Diminishing quality workmanship

Parsons' QC program identified 95 deficiencies warranting individual NCRs. Deficiencies cited in the NCRs include:

- "using bad quality of galvanized pipes without our approval at buildings G & D at the Cadet barracks"

- “segregation in the columns and beams”
- “using used and old materials (main valves and connectors), and covered it with concrete before testing and with out our approval for the 10” pipe water supply at Palestine street”
- “all welding points and connections are bad and out of specifications, and has been done by un skilled welder”
- “installing used fittings in potable water network”

Two significant NCRs documented poor construction techniques for the cadet barracks building and the laundry facility.

### **Cadet Barracks**

The cadet barracks’ NCR, dated 17 January 2006, stated “bad repair for sewage pipes through the slabs in Cadet Barracks Bathrooms” and included two photographs, which provided visual evidence of the improper connection and sealing of pipes (Site Photos 37 and 38). The NCR did not recommend any potential corrective actions nor did it mention if any corrective actions were taken to remedy the problem.

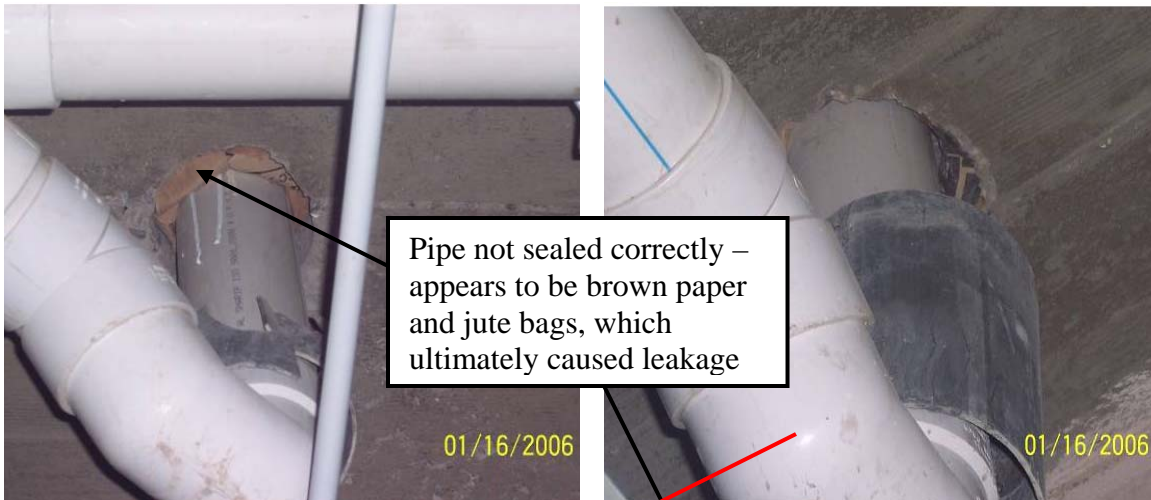
During our initial site visit, we identified either the same pipe (or one constructed in a similar manner), which confirmed the contractor did not take any corrective action to the NCR (Site Photos 39 and 40). The inability to act upon the NCRs resulted in the significant plumbing issues associated with the cadet barracks buildings. The poor soil pipe sealing work allowed waste water and solids to drain outside rather than inside the pipe, resulting in waste water leakage (Site Photos 41 and 42), which was a contributing factor to the significant water damage we witnessed on the ground floor.

The contractor had the opportunity in January 2006 to institute corrective actions to avoid further compounding the problem; however, the fact that upon our visit and return visits to the site from 8 to 10 months later we documented the existence of urine and fecal matter dripping from the ceiling, it is apparent the contractor did not take any corrective actions. As a result, the unsanitary conditions continue.

Further, had the contractor’s QCR or project engineer inspected the plumbing issues identified in the NCR, he would have seen that the contractor was using non-industry standard plumbing fittings and installation methods. The contractor used pipes with holes that were hand cut and had secondary pipes inserted rather than the appropriate factory manufactured standard pipe fittings and components (Site Photo 3). Significant issues resulted from the poor installation of plumbing pipes and the use of non-industry standard fittings.

The final cause of the waste water leakage throughout the cadet barracks appears to be inadequate sealing of pipes, which resulted in waste water flowing outside of the pipes (Site Photos 43 and 44). The pipe sealing should have been caught by the contractor’s QCR or project engineer during installation and also through testing. The absence of proactive responses by the contractor allowed the plumbing issues to go unresolved. As a result, the cadet barracks’ bathrooms had to be torn up and redone; the Iraqi police cadets were subjected to waste water raining down upon them; and BPC did not have full use of the cadet barracks.

During our return site visits in November and December 2006, we again identified water leakages in the cadet barracks (Site Photos 41-44). While it appears this time the contractor did not use the non-industry standard pipes that contributed to the original leakage problem, the continuing issue of poor quality installation and inadequate seals between the soil pipe and fittings remained. The contractor QCR and/or project engineer failed to adequately perform oversight of the plumbing installation to ensure quality workmanship. As a result, the problem identified in the NCR in January 2006 continues to exist today.

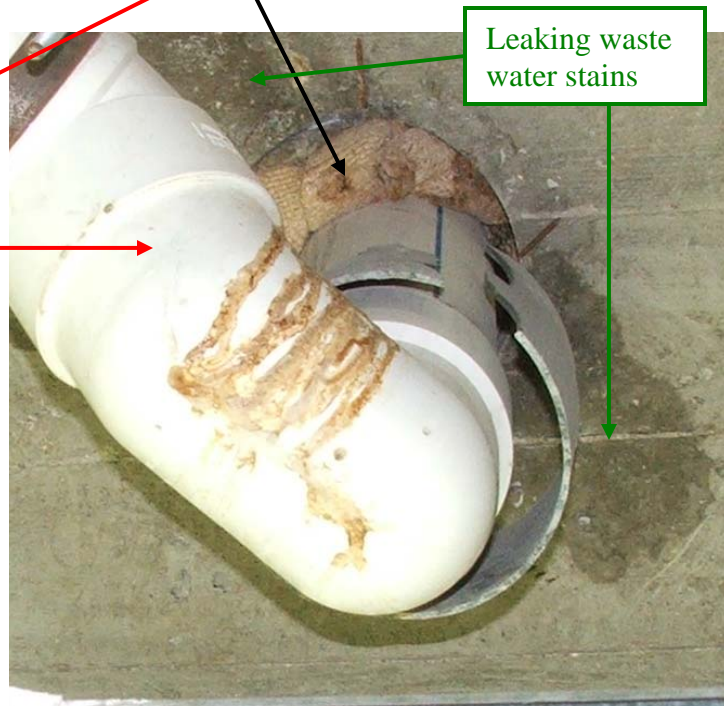


Pipe not sealed correctly – appears to be brown paper and jute bags, which ultimately caused leakage

Site Photos 37 & 38. Examples of poor quality work identified in Parsons’ NCR (Photos courtesy of the USACE)



Site Photo 39. Plumbing installation in cadet barracks in August 2006

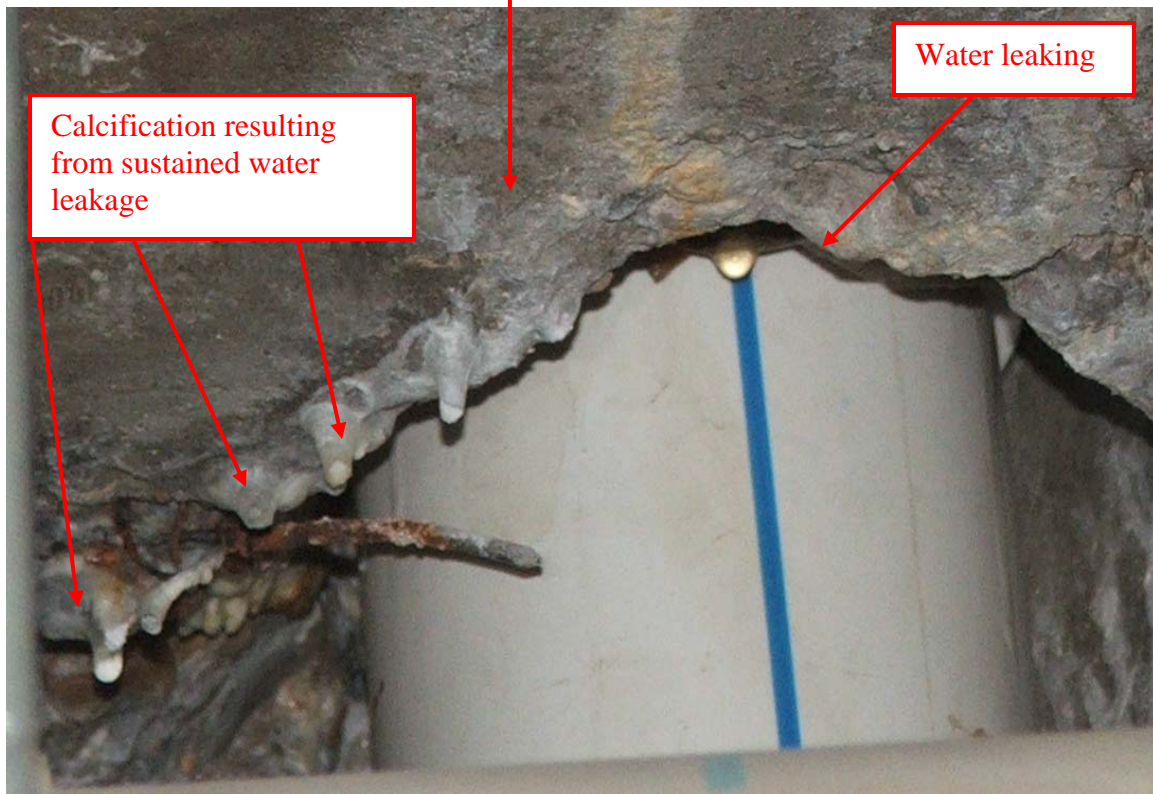


Leaking waste water stains

Site Photo 40. Enlarged view of Site Photo 39



**Site Photo 41. Water leaking from poorly installed drain in cadet barracks**



**Site Photo 42. Enlarged view of Site Photo 41**



December 2006

Site Photo 43. Leaking waste water from poorly sealed pipes



Site Photo 44. Enlarged view of Site Photo 43

### Central Laundry Facility

The contractor completed a NCR for the laundry facility on 17 October 2005, which stated:

*“The form work of the elevated slab is being removed and we are seeing areas where concrete cover does not exist. Concrete segregation in column necks, beams, and some slab areas. Reinforcement steel is exposed in some cases, especially when there are many electric conduits and large number of rebar. We have cases where cavities in connection between column & beam.”*

A knowledgeable, experienced, and well qualified full time QC program was required at the construction site to ensure the quality of the contractor’s work. Parsons relied upon local national (LN) QC engineers to visit the construction sites. However, it appears the LN QC engineers were not effective. For example, while the QC engineer completed a NCR for the laundry facility, the NCR was dated 17 October 2005, and there is no previous mention in any daily QC reports of concrete segregation or reinforcement bar exposure. With the significant



deficiencies related to structural stability documented earlier in this report for the laundry facility, it appears the LN QC engineers did not thoroughly inspect the laundry facility as it was being constructed. Construction began on the laundry facility in February 2005, yet the obvious construction deficiencies (see Site Photo 45) were only identified by the QC project engineer in October 2005. This further establishes that no one inspected the following prior to reinforced concrete structural elements being constructed:

- integrity and effectiveness of formwork for the columns/beams/slabs
- correct and accurate placement of structural steel reinforcement bars
- measuring required concrete cover
- correct locations of electrical conduits
- the required placement of dowel bars for lintels

The quality of concrete work also suggests the lack of use of a vibrator to consolidate concrete to form a homogeneous structure. By the time the QC engineers identified the substantial construction deficiencies for the laundry facility, it was too late to take corrective actions. Consequently, Parsons' QC program was not adequate to identify and correct a \$675,000 building, which resulted in approximately \$350,000 in construction costs and another estimated \$100,000 to ultimately demolish the building.

In addition, the QC engineers did not identify the deficiencies either discovered during our site visits or listed in the punch lists for the Beneficial Occupancy forms, such as the following:

- the concrete honeycombing and segregation and reinforcement bar exposure in the cadet barracks buildings
- the sloped floor in classroom building E
- the omission of a kitchen for the dining facility
- the range administration building sewer system was lower than the overall academy sewer system
- improper installation of roof flooring for all classroom buildings, range control building, library, instructors' barracks, language instructors' barracks, forensic lab building, workshop building, and motor pool building
- massive expansion cracks in the instructors' barracks

Finally, even though 95 NCRs were completed documenting construction deficiencies, only 58 contained potential corrective actions to be taken, and only 7 confirmed corrective actions were taken. Consequently, even though the QC engineers identified and documented 95 construction deficiencies, only 7 were reported to be corrected. At the time this report was issued, Parsons has been unable to provide any documentation to indicate corrective actions were taken for the remaining 88 construction deficiencies.

At this time, it is unknown if Parsons provided the NCRs immediately to the government for its review and action. A Parsons representative stated that the USACE's on-site "Quality Assurance Representative has access to Parsons' Quality Control Representative and Daily Quality Control Reports and

Nonconformance Reports.” Further, the Parsons representative stated “there is no contractual requirement to submit Nonconformance Reports to USACE.” However, according to Parsons’ QC plan for the BPC, it states the “NCR shall be attached to the DQCR (Daily Quality Control Report) and transmitted to the COR (Contracting Officer Representative). The COR, at their discretion, may make comments or recommendations.” To date, Parsons has been unable to provide any documentation to show it transmitted the NCRs to the COR. Parsons did include the NCRs in the turnover package of documents submitted to the USACE at the end of the project.



Site Photo 45. Improperly placed and exposed reinforcement bar, PVC conduit, and rust

### **Government Quality Assurance**

USACE ER 1110-1-12 and the PCO Standard Operating Procedure (SOP) CN-100 specified requirements for a government QA program. Specifically, PCO SOP CN-100 provides guidance for the GRD staffs to “...ascertain if the contractor CQC (Contractor Quality Control) system is functioning and the specified level of construction quality is being attained.” In order to accomplish this, PCO SOP CN-100 requires the following:

- The government QA Representative (QAR) “...shall review each CQC daily report. If the report is complete and accurate, it shall be forwarded to the project engineer or RE (Resident Engineer) for review. If not, the QAR shall require the contractor to submit a supplement to the CQC daily report and then forward it.”
- The QAR “...shall enter the necessary information for the QA report into the RMS (Resident Management System) QA report module for each day inspections are conducted at the work site.”
- The RE “...shall review the daily reports and monitor the contractor’s performance with regard to the results of its CQC system. If the CQC system is not consistently ensuring work is being performed IAW (in accordance

with) the contract requirements, the RE shall take appropriate steps as outline in EP (Engineering Pamphlet) 415-1-260, paragraph 8-1.b.(6)(b).”

- The “signed CQC report shall be initialed by the RE and placed in the project file.”

Similar to the QC program, a crucial oversight technique is presence at the construction site. The USACE Gulf Region Central (GRC), which was responsible for administration of the Baghdad Police College TOs under its parent organization, GRD, relied upon LN QA engineers to act as the QAR and visit the construction site. However, it appears the LN QARs were not effective. First of all, GRC was only able to provide daily QA reports from July 2005 through February 2006 and May 2006 through August 2006. For the months of October 2004, April 2006, and June 2006, only a combined 13 daily QA reports were completed. Considering construction began in July 2004, there is an absence of daily QA reports for almost the entire first year of construction.

We reviewed the LN QAR’s daily reports and determined the QA daily reports were vague regarding the work performed (“painting, backfilling for side walks, false ceiling installation, mosaic bringing and rendering are ongoing”) and provided little insight into the problems encountered at the site. Specifically, the QARs failed to identify any construction deficiencies at the site. The daily QA reports do not document any deficiencies noted by the QARs.

For example, the laundry facility was so poorly constructed that a stop work order was issued and multiple assessments were made to determine if the construction deficiencies could be corrected. The contractor’s QCR identified the “concrete segregation in column necks, beams, and some slab areas” and reinforcement bar exposure; however, not a single daily QA report mentioned a construction deficiency for the laundry facility. The QAR did not identify the concrete deficiencies for the laundry facility. The areas of concrete segregation, reinforcement bar exposure, and electrical conduit exposure are obvious and in plain view (Site Photos 46-50).

Parsons completed a NCR for the laundry facility on 17 October 2005, stopped work on the facility, and notified USACE representatives on 24 October 2005; however, the 27 October 2005 daily QA report states the following for the laundry facility: “electric works, plastering and brickwork are running.” The daily QA report does not mention the construction deficiencies identified by Parsons nor the fact that work had temporarily stopped at the facility. The 30 October 2005 daily QA report included a photograph of the interior of the laundry facility (Site Photo 51), however, again there was no mention of any construction deficiencies, simply the statement that “brick work for partitions are running.”

In the 26 November 2005 daily QA report, the QAR included a photograph from the interior of the laundry facility (Site Photos 51 and 52), which is almost identical to the photograph from the 30 October 2005 daily QA report, but did not mention any existing construction problems; rather, the report simply states “sanitary works are ongoing.” This daily QA report is over one month since Parsons discovered the massive concrete deficiencies throughout the facility. If Parsons did not bring the construction deficiencies to the USACE’s attention, work would have continued on the laundry facility, potentially increasing the dangers (and costs) associated with the building.



**Site Photo 46. Concrete segregation and exposed reinforcement bar  
(Photo courtesy of the USACE)**



**Site Photo 47. Electrical conduit exposure (Photo courtesy of the USACE)**



**Site Photo 48. Electrical conduit exposure and reinforcement bar rust  
(Photo courtesy of the USACE)**



**Site Photo 49. Concrete segregation and electrical conduit exposure  
(Photo courtesy of the USACE)**



**Site Photo 50. Concrete segregation, reinforcement bar and electrical conduit exposure (Photo courtesy of the USACE)**



**Site Photo 51. QAR daily report photo of interior of central laundry facility from the 26 November 2005 daily QA report (Photo courtesy of the USACE)**



**Site Photo 52. QAR daily report photo of interior of central laundry facility (Photo courtesy of the USACE)**

Further, the daily QA reports were not sufficiently complete and accurate. For example, the daily QA reports did not document the existence of the obvious construction deficiencies identified in this report, such as concrete segregation and honeycombing, reinforcement bar exposure, and poor plumbing installation in the cadet barracks. In addition, the “improper installation of roof flooring” in a majority of the buildings was noted by the GRD’s independent assessment report; however, this issue was never discovered nor noted in the daily QA reports. In classroom building E, we determined the ground floor sloped approximately 4” to the right (Site Photo 53); yet this was not recognized as a deficiency in the daily QA reports.



Floor slopes to the right approximately 4” – the QAR did not identify this as a deficiency

**Site Photo 53. View of poor construction for classroom E**

The QAR included photographs with each completed daily QA report. However, the QAR included only 5 to 8 photographs of the construction taking place at the BPC. Considering the amount of work required by both TOs, more than 5 to 8 photographs per day were needed. In addition, the majority of the submitted photographs were taken from the outside of the building/facility making it impossible to judge the quality of the interior work. For example, we reviewed all the daily QA reports and located approximately 6 interior photographs of the laundry facility; while we located a far greater number of exterior photographs (Site Photo 54). Further, the exterior photographs appear to be from a far distance from the building (Site Photo 55). It appears from the site photographs and the narratives within the daily QA reports that the QAR may not have been able to inspect each building on a daily basis.

In some cases, the daily QA report provided photographs of poor construction work; yet the narrative did not document the deficiency. For instance, one daily QA report included a photograph of poor concrete quality beneath a lintel (Site Photos 56-58); however, the narrative daily report did not mention this problem nor does it mention if the QAR brought this problem to the contractor's attention. Instead of documenting the deficiencies and proposing potential corrective actions, the daily QA report simply stated "No activity" on that particular day for the laundry facility. By review of the daily QA reports, we were unable to determine if the contractor corrected this problem. It appears that the QAR did not receive proper training to identify poor workmanship issues.



**Site Photo 54. Exterior view of the central laundry facility  
(Photo courtesy of the USACE QAR daily report)**

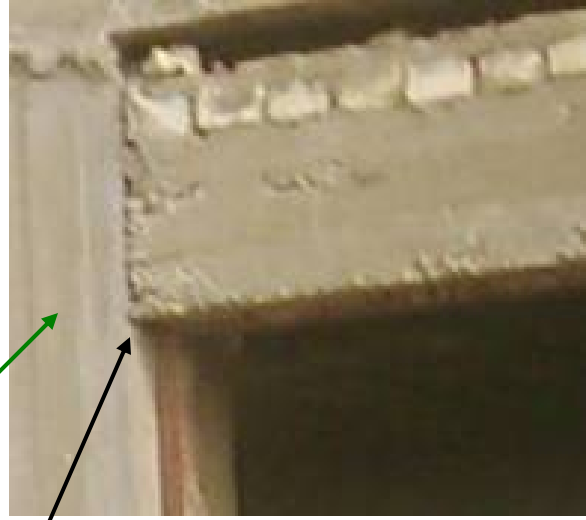


**Site Photo 55. Exterior view of the motor pool  
(Photo courtesy of the USACE QAR daily report)**

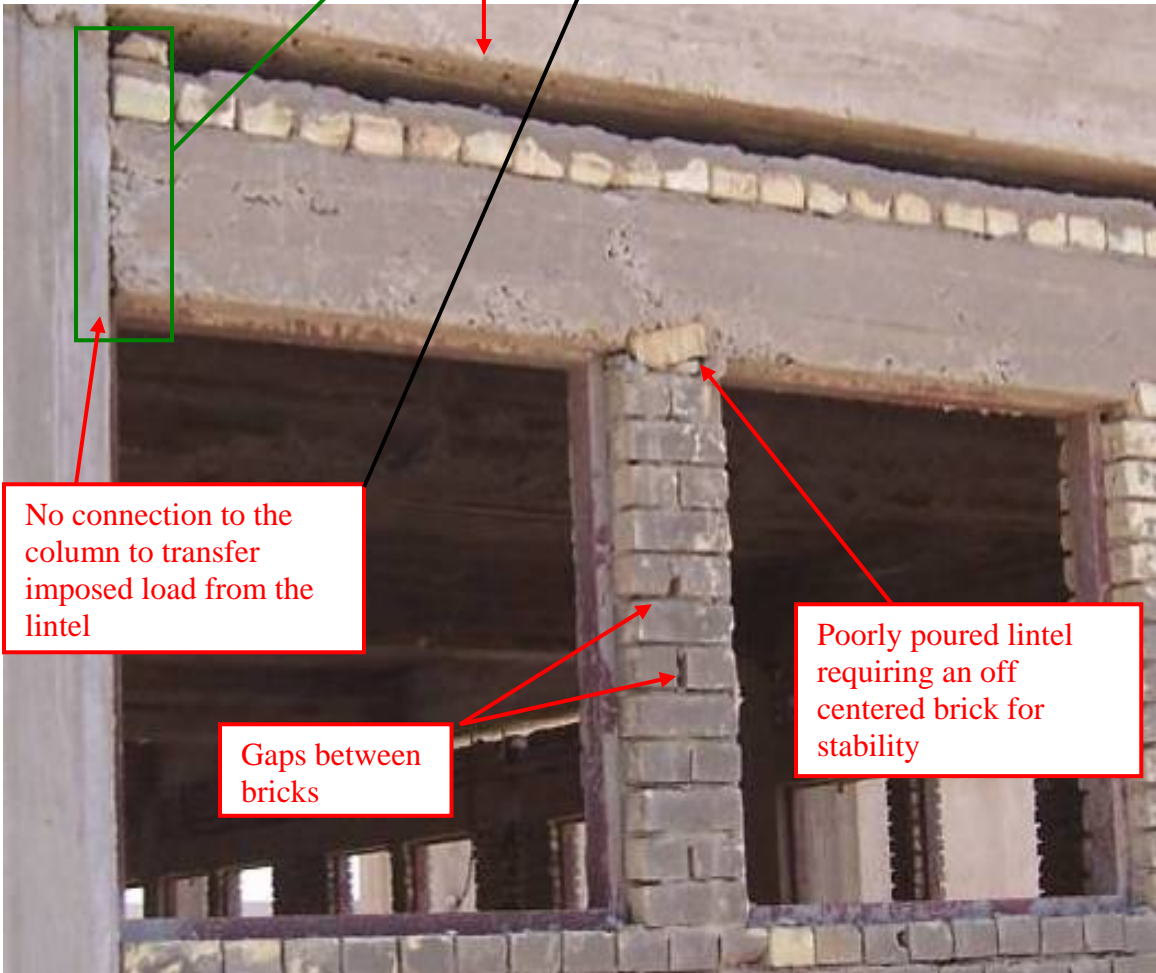




Site Photo 56. QAR provided photograph of poor construction (Photo courtesy of the USACE)



Site Photo 57. Enlarged portion of Site Photo 58



Site Photo 58. Enlarged section of Site Photo 56, detailing poor construction practices

The USACE GRC Project Engineer did not effectively review the daily reports and monitor the performance of the LN QA engineers. The LN QAR periodically provided the USACE GRC Project Engineer photographic evidence of poor concrete workmanship (Site Photo 57), yet there is no indication that the Project Engineer tried to correct this issue. Further, the USACE Project Engineer and Resident Engineer did not effectively monitor performance of the LN QAR. The Project Engineer and Resident Engineer at a minimum should have periodically reviewed the LN QC and LN QA daily reports to determine the progress of the projects and the quality of the contractor's work. It does not appear that either the Project Engineer or the Resident Engineer thoroughly reviewed the daily reports. For example, the daily QC reports documented construction deficiencies; while the daily QA reports did not. On 19 September 2005, the daily QC report for the instructors' barracks stated:

*"Some of door lintel is higher and some are lower than the affix door height. That leaves a large space over frame. Sub-frames for bath windows were removed and re-fixed. Unpleasant brick work and badly fixed frames is appearing."*

While the daily QA report for 19 September 2005 for the instructors' barracks stated:

*"Plastering for left side is running. Sanitary for right side is running."*

The Project Engineer, upon realizing the QC and QA reports did not document the same condition at the site, was responsible for determining if construction deficiencies existed. There is no indication the Project Engineer did anything to determine the adequacy of the QC and QA daily report. Consequently, the potential construction deficiencies identified in this specific daily QC report were not addressed.

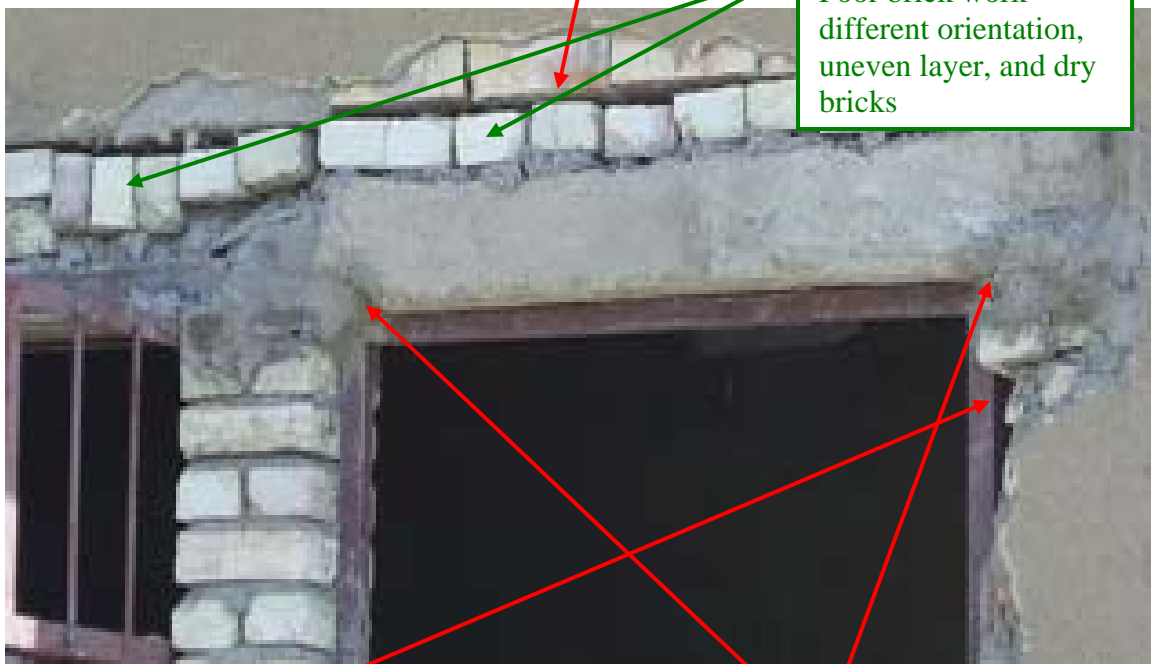
The Project Engineer should have realized the LN QAR was not effective after reviewing the daily QA and QC reports. First of all, it's not realistic to believe a project the size of the BPC could be constructed without deficiencies. Since the daily QA reports did not document any construction deficiencies, the Project Engineer should have questioned the QA engineer regarding this fact. There is no indication of such action by the Project Engineer. In addition, when the daily QC reports identified deficiencies and the QA reports did not, the Project Engineer needed to visit the site to determine the actual conditions of the project and reconcile the differences in the reports.

The GRC needed to question the skills and capabilities of the QAR after Parsons identified the major construction deficiencies for the laundry facility. The QAR did not identify any construction deficiencies for a structure that ultimately required multiple technical assessments to determine if it could be safely repaired. The laundry facility construction deficiencies were so significant and so apparent that the GRC needed to reevaluate the qualifications of a QAR who did not identify any deficiencies. However, there is no indication that the GRC either reevaluated the QAR or even scrutinized his daily QA reports. As a result, the contractor was paid approximately \$350,000 for a partially built facility with so many deficiencies that it was ultimately de-scoped.

In one instance, photographic evidence of poor lintel and brick work was brought to the attention of the Project Engineer (Site Photos 59 and 60). This photograph was located in the GRC project file with the caption "Armory warehouse bad lential."



Site Photo 59. QAR provided photograph with caption “Armory warehouse bad lintel” (Photo courtesy of the USACE)



Poor brick work – different orientation, uneven layer, and dry bricks

Site Photo 60. Close-up section of Site Photo 59, documenting poor lintel construction practices

Gap between door frame and brick work

Very poor lintel construction – not enough support beneath

However, we could not determine if the QAR or the QCR identified the poor construction. The daily QA report for 3 October 2005 for the armory stated “sanitary, plastering, painting, aluminum doors and windows, installation Glassing, electric works and excavating for side walk are ongoing”; while there is no daily QC report for 3 October 2005. A deficiency log would document who identified the

construction deficiency, the corrective actions required, and when the corrective action was taken. PCO SOP CN-102 required implementing and maintaining a tracking log of all construction deficiencies discovered during quality control and quality assurance inspections to document that corrective actions have been taken. Without deficiency logs by either the QC or QA engineers, we could not identify who recognized the poor lintel construction; more importantly, there is no indication this deficiency was ever corrected.

After reviewing the available QA documentation for this project, we concluded a standard government QA program did not exist. In an effort to identify the causes of the shortcomings of the QA program we interviewed GRD and GRC personnel. According to current GRC personnel responsible for this project, "...this contract did not contain the implementing clauses necessary to put a functioning QC/QA program in place and no staff was provided." Current GRC personnel state that at the time he was assigned the project, October 2005, there was "no definition of what 'QA services' were required."

Further, according to GRD representatives, the USACE GRC Project Engineer reviewed the daily LN QC reports and the daily LN QA reports; however, GRC personnel stated it was their "...belief that PCO assumed responsibility for project oversight and review of the QA reports. I heard no complaints from either the PCO or MNSTCI personnel reviewing the reports." As a result of this confusion, apparently neither GRC nor GRD/PCO reviewed the daily QA reports for accuracy and completeness.

Mentioned earlier was the fact that the LN QAR did not provide an adequate number of photographs to document construction quality and completeness. However, according to GRC personnel, the "number of pictures taken is irrelevant to a functional QC/QA program." But, in view of the fact that the GRC was relying completely on LN QARs to perform the QA oversight of this project, photographs and detailed narrative explanation of each photograph were crucial. However, since neither GRD nor GRC personnel reviewed the daily reports and photographs, apparently the number and quality of photographs was not important. As a result of not requiring an adequate number of detailed photographs and not reviewing the photographs, significant construction deficiencies were not identified and corrected, and the contractor was paid for work that did not meet contract design plans, specifications, and applicable construction codes.

With regard to the requirement for the QARs to review each CQC daily report for accuracy and completeness, GRC personnel stated there was "no requirement for them [QARs] to review Parson's documents." Not only did this practice violate established USACE procedures, it also meant no one reviewed the CQC daily reports. Consequently, deficiencies identified by the QCR were not tracked to guarantee corrective actions were taken. In addition, since the QARs felt that there was "no requirement" to review Parsons' documentation, even if Parsons submitted the NCRs to the QARs, they would not have been reviewed. As mentioned in the "Contractor's Quality Control Program" section, the NCR which identified the "bad repair for the sewage pipes through the slabs in Cadet Barracks Bathrooms" presented both the contractor and the government with the opportunity to correct a significant problem prior to completing construction and moving cadets into the barracks. The inability to act upon the NCR resulted in the significant plumbing issues the BPC is still dealing with today. The Project Engineer had the opportunity in January 2006 to institute corrective actions to avoid the problem; however, since

the GRC Project Engineer did not review the daily QA reports, it is unlikely he would have reviewed the NCRs or taken any corrective actions.

Even though the NCRs were provided to the GRD as part of the “turnover package,” no one from GRD has reviewed them. When we asked about the NCRs, GRD and PCO representatives stated they were unaware of them.

It appears from the USACE’s perspective, from the start, it was more important to ensure completion of the project than quality of the project. According to GRC personnel, the “overwhelming emphasis of this contract during my tenure was project completion, the QA Reports were clearly focused on tracking progress toward that completion.” In addition, according to GRC personnel, the QA reports “do not contain a block for quality issues.” We did confirm that the “Quality Assurance Report” in use did not contain a section to report on the quality of construction. Finally, according to GRC personnel, even though the “QAR’s did not identify numerous quality issues...I believe that the Iraqi QA reports met the requirements of the QAR contract.”

### **Quality Assurance Since Our Initial Visit**

The subcontractor agreed to fix all cadet barracks building plumbing issues at no additional cost to the government. Considering the causes of the plumbing problems were the improper sealing of the pipes to the floor drains and other pipes and the use of non-industry standard pipe fittings, the need for the Project Engineer and the QAR to verify during construction that the new plumbing fixtures were properly installed was critical. After being told the plumbing issues had been resolved, we made a follow-up visit to the BPC in November 2006. We witnessed what appeared to be the same plumbing issue as before – leaking waste water from the improper sealing of the pipes (Site Photo 61). However, it appears that neither the Project Engineer nor the QAR supervised or verified the proper installation of the plumbing rework.

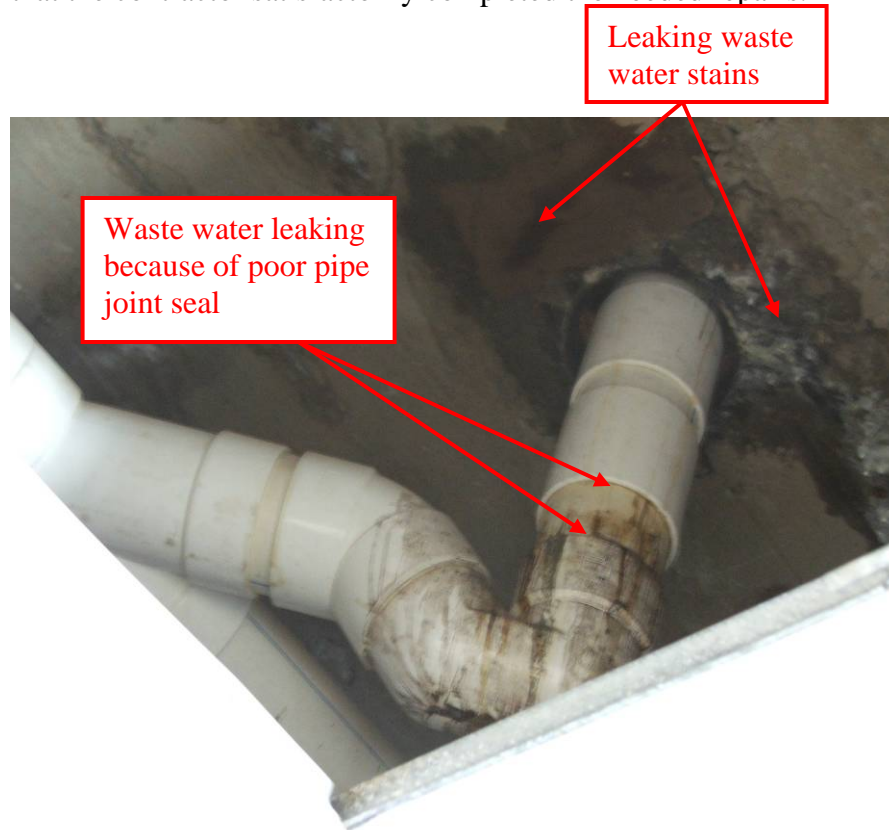
Further, a meeting was held on 11 September 2006, with GRD, MNSTC-I, Civilian Police Assistance Training Team (CPATT), GRC, BPC, and Special Inspector General for Iraq Reconstruction (SIGIR) personnel. BPC representatives stated that they had been the de facto “quality assurance representatives” because of a lack of GRD oversight and stressed the importance of daily on-site QA personnel to inspect the contractor’s work. GRD agreed to provide additional personnel to scrutinize the contractor’s work. While the new LN QARs provided more detailed daily QA reports, including construction deficiencies, the LN QARs again did not identify and correct the original plumbing issues. During our November 2006 visit, the Iraqi police cadets stated that the water had been leaking for approximately 4-5 days, which was confirmed by the bucket of water that had accumulated. BPC representatives had to contact GRD representatives regarding the water leak.

In addition, on 6 November 2006, a BPC representative submitted an email to a GRD representative regarding the alleged repair of the classroom E building. The BPC representative stated that he took a walk through the building in “preparation for this morning’s incoming Basic class (1200 students/three buildings). It was our understanding that the building (repairs) was/were completed...” The email continued with the following:

*“A five minute cursory check of the ground floor toilets showed that at least five of the toilets and several of the lavs did not function. Some appeared to have mechanical problems, and some had no water supply, either none at all*

*or extremely low pressure to the point of malfunction...The toilets on the second floor appear to have the same problems, including little or no pressure. There are fixtures and hose connections leaking in a number of places...I cannot place the incoming students in this building at this point, because they will over-react to the non-functioning toilets and cause more damage...It is imperative that the engineering staff, or whoever the responsible person is for this task, personally test each and every toilet and lav/sink – one at a time – to make certain the workers are in fact finishing the repair work...”*

Again, it appears that GRD has continued to not adequately staff this project to verify that the contractor satisfactorily completed the needed repairs.



**Site Photo 61. November 2006 SIGIR Inspections photograph of contractor’s plumbing rework. Photo illustrates improper sealing of pipes.**

### **Overall Quality Management**

It appears that Parsons did not effectively manage the construction of the BPC. Parsons was required to manage the construction of the project and provide QC. Even though the daily QC reports and NCRs identified construction deficiencies, there is no indication corrective actions were taken for a majority of the deficiencies.

It also appears the USACE did not provide adequate oversight of the construction of the BPC. The USACE was responsible for providing QA oversight of the construction for the U.S. government. However, GRC believed it was responsible for only a “limited Quality Assurance role” for the BPC. GRC personnel believed that “PCO assumed responsibility for project oversight and review of the QA

reports;” while GRD/PCO personnel believed the GRC Project Engineer was responsible for reviewing the QC and QA daily reports.

During the 11 September 2006 meeting, it was determined that this project was not “adequately staffed” by the U.S. Government. According to GRC personnel, there were four or five LN QARs assigned to this project; however, there was no assurance that the LN QARs worked on the project simultaneously. In addition, there was one Project Engineer to oversee a \$75 million project, with multiple buildings spread throughout a large campus. For the USACE GRD’s role as construction QA overseer, their fee is 4% of the TO value. To date, the USACE GRD has been paid approximately \$2.2 million for its QA function, which will increase to approximately \$2.5 million once Parsons’ remaining invoices are received and paid.

For the size, complexity, and importance of this project, the USACE GRC should have followed the established guidance of PCO SOP CN-100, which required the QARs to review each contractor QC daily report and enter QA information into RMS and that the Resident Engineer review the contractor’s QC program, specifically the QC daily reports. In addition, the GRC personnel needed to require the LN QARs to document construction deficiencies and thoroughly review the daily QA reports for completeness and accuracy. The role of the LN QAR in a QA program is to identify construction deficiencies for the U.S. Government; however, the GRC personnel instead used them simply to track project progress.

Ineffective on-site management and the lack of adequate government oversight at the BPC resulted in significant and continuing construction quality issues, cost overruns, and schedule delays.

## **Review of Contractor Payment Invoices**

The USACE GRC stated they did not review the contractor’s invoices prior to payment. Modification 0002 of the contract required the submission of invoices directly to the DCAA offices for review and provisional approval and to the Contracting Officer and to the USACE Finance Center, Millington, TN. Neither the DCAA nor the USACE Finance Center Millington requested the USACE GRC Resident or Project Engineer or the on-site QAR responsible for the BPC to review or approve the invoices to validate the work claimed by the contractor.

GRD representatives stated that the BPC contract is a “cost plus award fee contract, and as such, Parsons is entitled to be reimbursed for all costs plus their base and award fee. Payment is not dependent on percent complete, but cost incurred. As such, if Parsons submits an invoice with backup documentation that they have incurred cost related to the project, then they are entitled to payment.” According to GRD representatives, “all invoices are reviewed by the Project Manager, who compares the invoice to the submitted backup documentation, prior to payment.”

PCO CN-107 “Process Construction Interim Payments (Cost Plus),” states that the resident engineer is responsible for entering the pay activities submitted by the Design Build (DB) contractor into RMS and reviewing the DB contractor’s interim invoice and listing costs, which appear to be questionable. This policy also states, “the PCO and GRD staffs must review interim invoices for cost reimbursable task orders ensuring costs are reasonable, allocable, and allowable and invoices are processed within the timeframe set forth by the prompt payments clause of the contract.”

Our concern with the GRC Resident or Project Engineer and QAR not reviewing contractor invoices prior to payment is the contractor being paid for work that does not meet the contract's requirements. During the course of our site visit, we observed several instances of construction work which did not meet the contract's requirements; however, the contractor received payment for this non-compliant work since the USACE Finance Center Millington did not request the GRC Resident or Project Engineer or the QAR responsible for the BPC to review and approve the invoices. For example, Parsons submitted invoices and was paid \$348,332 for the laundry facility; however, the construction deficiencies associated with the laundry facility are so significant and potentially hazardous that the MNSTC-I has decided it is safer and more cost effective to spend approximately \$100,000 demolishing the structure and to contract to have another laundry facility built.

## **Test Results and As-Built Drawings**

### **Test Results**

As part of its close out documentation, Parsons provided GRD with its testing results. According to Parsons' documentation for the cadet barracks buildings, the PPR (Polypropylene Random – pressure piping for hot and cold water system) pipes, sewer pipes, and rain water pipes were separately tested. The PPR test consisted of start and stop atmospheric pressures of 6.0 bar, or approximately 87 pounds per square inch (psi) (1 bar = 14.50377 psi), for 48 hours, with no reported water leakage. The sewer pipe test consisted of plugging the pipe openings and filling the pipes with water for 48 hours; there was no reported water leakage. The testing procedure for the rain water pipes was identical to the sewer pipe test, with no reported water leakage. According to the plumbing test log, cadet barracks buildings A, B, C, and D were tested and there was no water leakage. After considering the non-industry standard plumbing fittings were used in the cadet barracks bathrooms (Site Photo 62), the poor joint sealant work done by the subcontractor (Site Photo 63), and the end result of the plumbing deficiencies (Site Photo 64), we question Parsons' test results.

We documented the massive leakage problem with the non-industry standard plumbing pipe fittings in an earlier inspection report. Instead of using a "tree" shaped standard fitting, the subcontractor created his own makeshift version by drilling/punching holes through the pipe and inserting another pipe through it. It will be virtually impossible, by normal means, to make these joints water tight. In addition, it does not appear the subcontractor used any epoxy material to seal the inserted pipe into the main pipe. Therefore, it is difficult to believe that the sewer pipes were plugged and filled with water for 48 hours without leaking. Further, there is no date for the Parsons' alleged plumbing test; however, on 17 January 2006, a NCR was completed with the statement "bad repair for sewage pipes through the slabs in Cadet Barracks Bathrooms." This NCR casts further doubt on the reliability of the plumbing tests. In addition, three site engineers from Parsons signed off on the plumbing test log without any government representatives witnessing the tests. There is no explanation as to why USACE personnel were not present for the testing process, as is required for standard QA processes.



Parsons also had plumbing test logs for instructors' barracks A-D, which had handwritten notes stating:

*“Sewer pipes were tested by filling the pipes with water for 48 hours. PPR pipes were tested by filling the pipes with water and pressure them by 6 bar for 48 hours. There was no water leakage for the two items above.”*

As a result of our earlier inspection report, GRD hired a consultant to conduct an assessment of the buildings, sewer, and water systems. In the assessment, it stated the following for the instructors' barracks A and B:

*“Substandard joint connections of drain pipes from wash basin and showers. Method used of drilling the P.V.C. pipe and connecting to another pipe is not standard construction practice due to the potential of water leakage through such unsealed joints.”*

The assessment determined the same non-standard method to assemble soil pipe joints was used for the sewer pipes in the instructors' barracks as was used in the cadet barracks. Therefore, again it is difficult to believe that the sewer pipes and connections remained water tight while the same 48 hour leak detection test was performed. However, according to the plumbing test logs for the four instructors' buildings, a USACE representative was present for the testing of the sewer and PPR pipes for the first and second floors of each building.

It is not clear if the soil pipe and associated fittings/assemblies were tested with or without applied pressure; if they were tested under pressure, there is no documentation of water pressure readings and duration. It is also important to note that we found no evidence (either photographic or video) of the test setup or type of equipment used. The contractor's submitted test logs do not indicate the equipment type, brand name, model number, and names of the witnesses present. This required and customary documentation is absent to validate the available test result logs.

Finally, Parsons' test results log for classroom building C is similar to the log for the cadet barracks since it is not dated, used the same testing procedures, and no government representative signed off as witnessing the tests. The GRD independent assessment of classroom building C stated:

*“Abnormal fittings connected by drilling holes in PVC pipes and connecting them with another pipe is not an acceptable method of construction.”*

Since the installation method for the sewer pipes used for classroom building C is similar to the method used for the cadet barracks and instructors' barracks, it again appears unrealistic to believe that the sewer pipes would not leak during testing.

In conclusion, it appears the hydrostatic test logs provided for this project are highly suspect. The test results state that none of the sewer pipes in the cadet barracks, instructors' barracks, and classroom C leaked during testing; however, all of them subsequently leaked during normal usage.



**Site Photo 62. Non-industry standard plumbing fixtures**



**Site Photo 63. Example of poor sealing technique used by the contractor**



**Site Photo 64. End result of using non-industry standard plumbing fixtures and not sealing pipes correctly**

### **As-Built Drawings**

As-built drawings are a set of drawings which depicts the actual as-built conditions of the completed construction. They indicate any construction deviations from original design and show all features of the project as actually built. According to USACE ER 415-345-38, “customers must have complete, accurate and timely as-built information for proper operations and maintenance, effective warranty enforcement, and future repair and rehabilitation work.”

We mentioned in the design section of this report that GRD/PCO are not satisfied with the quality and accuracy of Parsons’ as-built drawings. An independent assessment of the plumbing issue resulted in the conclusion that the as-built drawings often did not match the existing field conditions. In some instances, the as-built drawings do not reflect the reality of the construction work performed.

For instance, for the instructors’ barracks, we identified significant expansion cracks on the interior, exterior, and roof of the buildings (Site Photos 65-68). Parsons’ as-built drawings claim to have constructed a specific type of expansion joint system for floor, interior wall, ceiling, exterior wall, and roof (Figures 5 and 6). The as-built drawings submitted show a very specific prefabricated engineered joint system. We found little or no evidence of designed joint systems in place to protect the building from vertical and horizontal movement. When comparing the building’s construction and damage to the as-built drawings submitted by Parsons, it is apparent that the as-built drawings do not reflect the actual construction done.

Similar to the instructors' barracks, we discovered significant expansion cracks on the interior and exterior of the language instructors' barracks (Site Photos 69 and 70). Parsons' as-built drawings required a specific type of expansion joint system for floor, interior wall, ceiling, exterior wall, and roof (Figure 7). The as-built drawings submitted show a very specific prefabricated joint system. We found little or no evidence of designed joint systems in place to protect the building from vertical and horizontal movement. When comparing the building's construction and damage to the as-built drawings submitted by Parsons, it is apparent that the as-built drawings do not reflect the actual construction done.

Finally, for the ablation unit, the as-built drawings submitted by the contractor indicate the facility is connected to the main water and sewage networks (Figure 8); however, during our initial site visit, we verified the facility was not connected to either the main water or sewage networks (Site Photo 71). The connection to the main water and sewage networks was not completed until late November 2006 and was completed by another contractor.

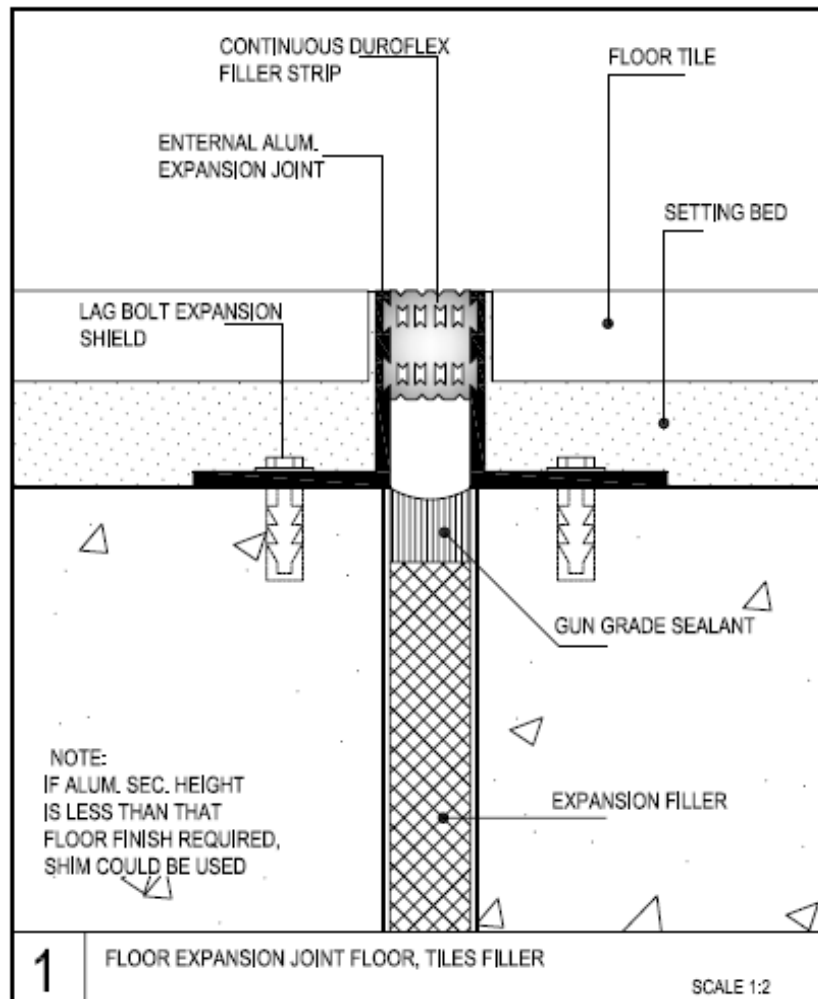
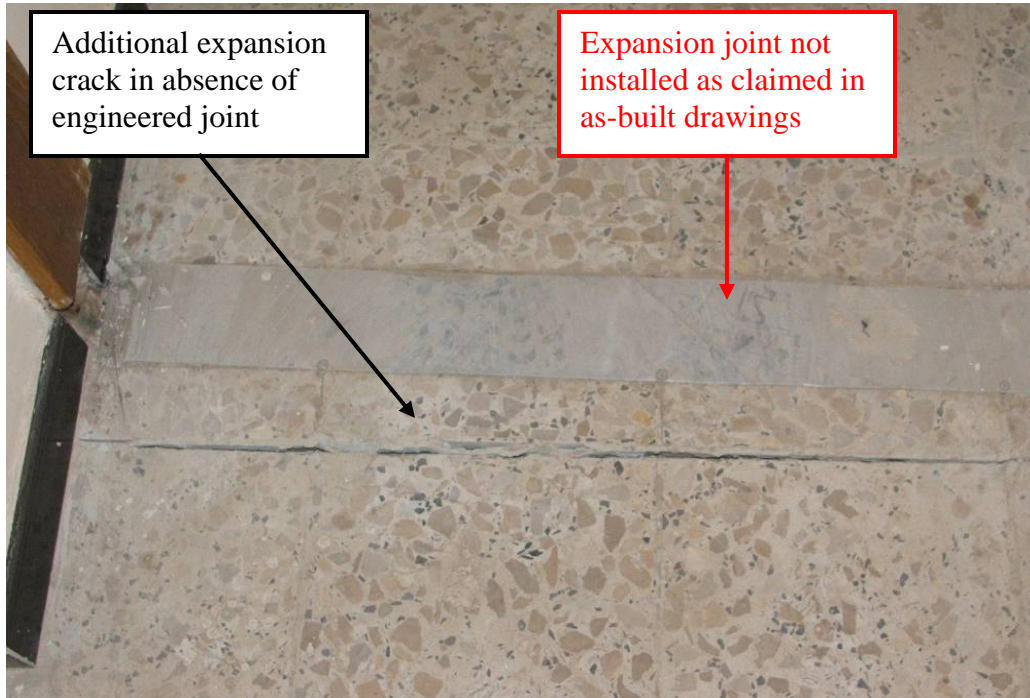


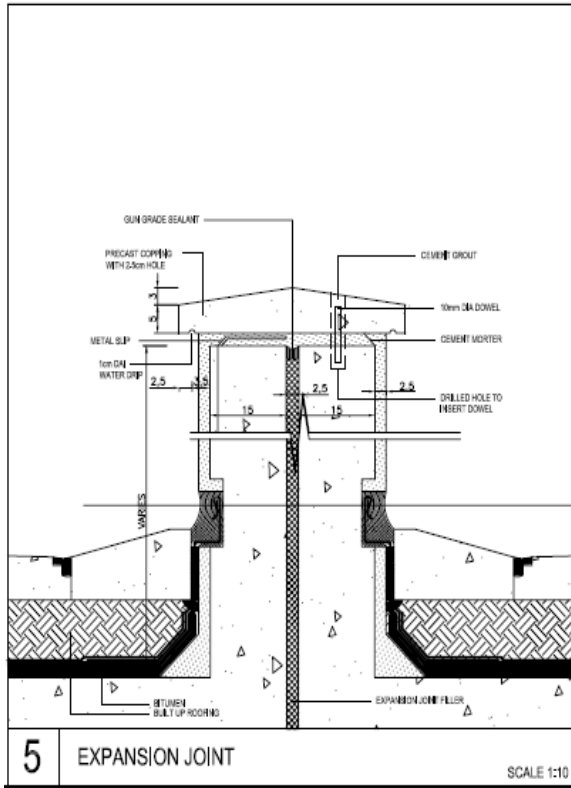
Figure 5. Contractor's as-built drawing



**Site Photo 65. Interior expansion crack in the instructors' barracks**



**Site Photo 66. Interior expansion crack in instructors' barracks**



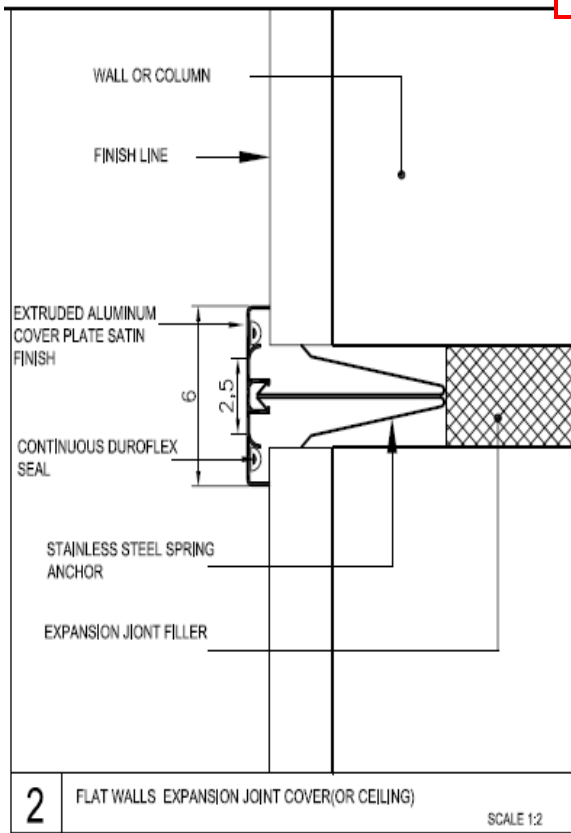
**Figure 6. Contractor's as-built drawing**



**Site Photo 67. Exterior expansion crack**

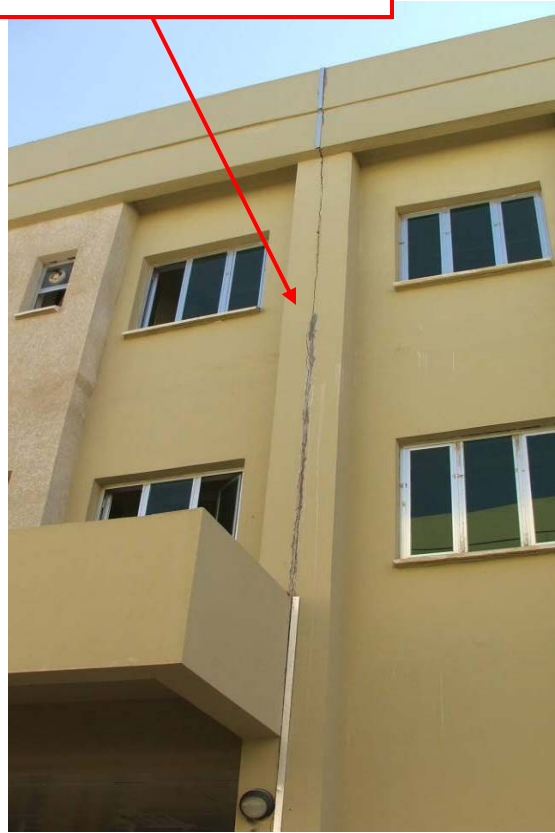


**Site Photo 68. Enlarged view of Site Photo 67.**

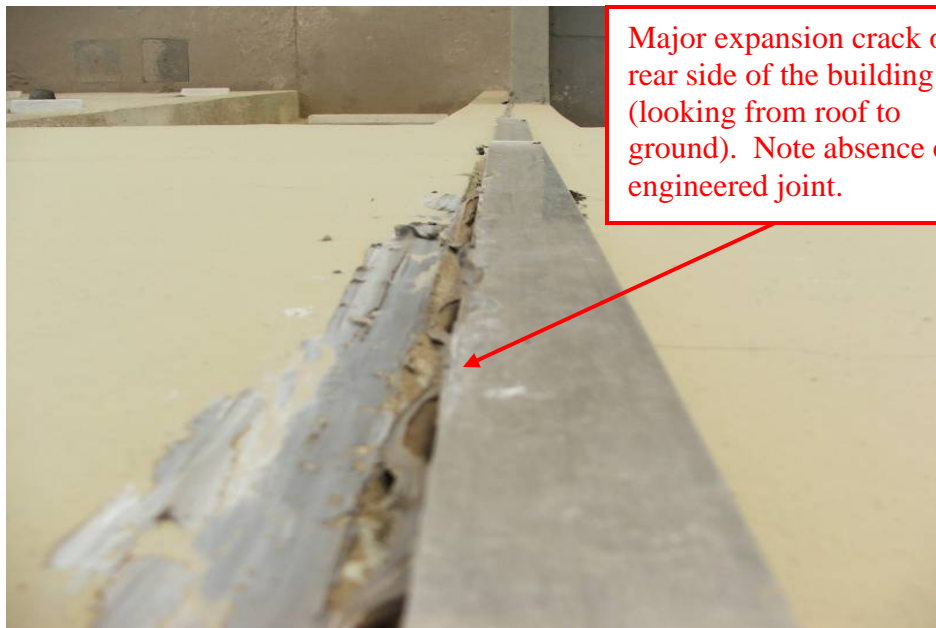


**Figure 7. Contractor's as-built drawing**

Major expansion crack on front side of building (absence of engineered joint)



**Site Photo 69. Exterior expansion crack**

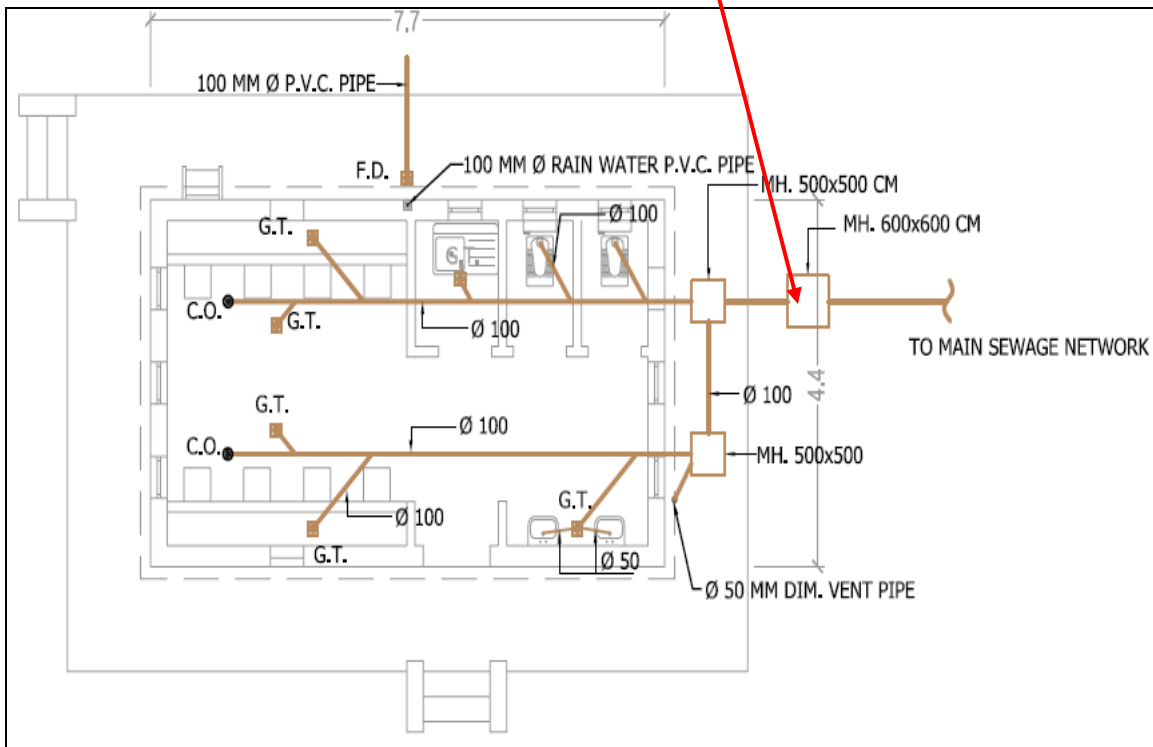


Major expansion crack on rear side of the building (looking from roof to ground). Note absence of engineered joint.

**Site Photo 70. Exterior expansion crack**



**Site Photo 71. 10 November 2006 site visit, documenting ablation unit not connected to the sewer network.**



**Figure 8. Contractor's as-built drawing for ablation unit, which indicates connection to main water and sewage networks.**



## Base and Award Fees

For cost-plus-award-fee contracts, the contractor has the opportunity to receive both a base fee and an award fee. The base fee is established in the contract at the time of the contract award; while the amount of the award fee may range from no fee to the maximum amounts listed in the Award Fee Plan for the award fee period specified. For cost-plus-award-fee contracts, the base fee is awarded for simply meeting contract requirements and merit based award fees are for performance that exceeds contract expectations. The highest base fee allowed by the Department of Defense Federal Acquisition Regulation (FAR) Supplement is 3%. The Army FAR Supplement 5116.405-2 states that “contractors should not receive award fees (above the base fee) for simply meeting contract requirements.” See Appendix H for details on award fees paid under this contract.

For the BPC project, the contract established a base fee of 3% and an award fee pool of 12%, applied against the negotiated, estimated cost of each contract TO. To date, the contractor has been paid a base fee of \$1,777,185; however, this amount will increase after Parsons submits its final invoices.

According to the Award Fee Plan, the amount earned by the contractor in whole or in part, is based upon an evaluation by the Award Fee Determination Official of the contractor’s performance. Award fee evaluations are to be performed at six month intervals. In order to evaluate the contractor’s performance for the Design-Build Technical Services and Management services, the following evaluation categories were developed:

### Technical

- Schedule adherence 30%
- Cost control 30%
- Technical services/quality control 30%
- Health and safety (contractor and public) 10%

### Management

- Program execution/quality management 40%
- Training, development, and transition 40%
- Utilization goals 20%

### October – December 2004

For the period October – December 2004, Parsons received approximately \$1.3 million in awards fees for TO 29. GRD provided us with the evaluation documentation used to justify this award to Parsons.

Under the Technical Evaluation section, Parsons’ performance was addressed as the following:

- *“Schedule was not adhered to as well as it should be. The milestones slipped on the major structure schedule...Parsons’ critical activities have not met established milestones deadlines. Parsons has been slow in mobilizing utilities...The DFAC was going to be delivered as a warm lit shell and not a usable facility...”*

- *“Drawings submitted generated major comments from the technical staff. For example, Parsons was to design a DFAC that will service hundreds of soldiers. Yet, the layout seemed to have been designed without much thought or consideration for flow or traffic. Essentially, they designed to sub-par standards.”*
- *“Daily reports met minimal expectations.”*

Even though the written justification documented the above mentioned deficiencies, Parsons was awarded 85% of the available awards fee pool, which equated to an overall rating of “Above Average.”

#### December 2004 – March 2005

For the period December 2004 – March 2005, Parsons received approximately \$1.2 million in awards fees for TO 06. In the GRD’s “DB Contractor Performance Evaluation Report,” GRD stated that Parsons’ drawings “generated no major comments from the technical staff.” However, this statement contradicts the 90% submittal review for the Specifications and Civil Drawings from February 2005, which stated the following:

*“Drawings submitted are incomplete and lack information for the implementation of the project. They are more like 30 to 40% complete and are no way near 90% complete. Details are incomplete and legends/symbols do not match. No profiles have been drawn for the water and sewer lines. Critical dimensions have not been shown or indicated. Drawings do not identify their purpose. They do not identify new from existing work. We are therefore rejecting this entire submittal. Please revise and resubmit.”*

In addition, the evaluation report also stated that “Quality control is evident on the site. Only minor deficiencies were noted.” However, during this time frame, 3 NCRs were completed for significant construction deficiencies, such as “putting (sic) layer of subbase (sic) directly on mud & water without using hard rock on that weak area,” “subbase (sic) layer of 25 cm without compaction,” and “stirrups for columns not according to the design for building A.” Even though the NCRs documented the significant construction deficiencies, the NCRs do not indicate that corrective actions were taken. Therefore, the contractor’s QC may have been “evident” through the use of NCRs; however, it was not effective in making corrective actions.

For TO 29, Parsons received no award fees because certain construction percentage completion requirements were not achieved; however, the written justification for their work was identical to the language used for TO 06.

#### March – September 2005

For the period March – September 2005, Parsons received approximately \$1.1 million in awards fees for TO 06 and TO 29. GRD was unable to provide us with the evaluation documentation used to justify this award to Parsons.

During this time frame, the electrical infrastructure design drawing submittal was deemed “not acceptable as 100% submittal as it is incomplete, inaccurate and substandard” and the 100% electrical design drawing submittal for the motor pool and ablution unit was “rejected.”

In addition, 21 NCRs were completed between March 2005 and September 2005. Significant construction deficiencies identified in the NCRs included:

- “using bad quality of galvanized pipes without our approval at buildings G & D at the Cadet barracks”
- “using used and old materials (main valves and connectors), and covered it with concrete before testing and with out our approval for the 10” pipe water supply at Palestine street”
- “all welding points and connections are bad and out of specifications, and has been done by un skilled welder” and
- “PPR water pipes in bathrooms moving on the ground beneath ceramic tiles. Pipes were worked without sleeves to cover. Contractor shows careless for the waterproofing treatment for the floor before working these pipes. This could cause water leak to the spaces under the bathroom.”

#### September 2005 – March 2006

According to the GRD representatives, no award fee was given for this time period because the contractor was not eligible based on lack of progress at the BPC.

During this time frame, Parsons completed 61 NCRs for significant construction deficiencies. Included within the 61 NCRs is the one from January 2006 identifying poor plumbing installation in the cadet barracks bathrooms; a deficiency Parsons not only did not address at the time, but, to date, has still not adequately corrected the problem.

#### March 2006 – September 2006

The Award Fee Board has not yet met for this time period. According to GRD representatives, the total award fee pool for this period is approximately \$1.7 million.

During this time frame, Parsons completed 18 NCRs for significant construction deficiencies. Included within the 18 NCRs is the one from March 2006 identifying the subcontractor “did not use a vibrator to prevent segregation & cavities in concrete – the concrete base has large areas of segregation” and “used wire size 2.5mm<sup>2</sup> for power connection between AC electric outlet and outdoor unit for the AC split unit 24000 BTU & Free stand 60000 BTU.” There is no documentation available to support the subcontractor corrected these problems.

## **Project Sustainability**

The contract’s Warranty of Construction clause stated that the contractor warrants that work performed under this contract conforms to the contract requirements and is free of any defect in equipment, material, or design furnished, or workmanship performed by the contractor or any subcontractor or supplier at any tier. This warranty shall continue for a period of 1 year from the date of final acceptance of the work. If the government takes possession of any part of the work before final acceptance, this warranty shall continue for a period of 1 year from the date the government takes possession.

The contractor shall remedy at the contractor’s expense any failure to conform, or any defect. In addition, the contractor shall remedy at the contractor’s expense any damage to

government owned or controlled real or personal property, when the damage is the result of the following:

- the contractor's failure to conform to contract requirements
- any defect of equipment, material, workmanship, or design furnished

The contractor shall restore any work damaged in fulfilling the terms and conditions of this clause. The contractor's warranty with respect to work repaired or replaced will run for 1 year from the date of repair or replacement.

If the contractor fails to remedy any failure, defect, or damage within a reasonable time after receipt of notice, the government shall have the right to replace, repair, or otherwise remedy the failure, defect, or damage at the contractor's expense.

The TO specifications required that the contractor provide and certify warranties in the name of the appropriate Ministry, for all equipment, which includes any mechanical, electrical, and/or electronic devices, and all operations for 12 months after issuance of the Taking-Over-Certificate. In addition, the contractor was to provide any other commonly offered extended warranties for equipment and machinery purchased.

All electrical/mechanical equipment, steel structures, turbines, generators, computer controls, wiring, spare parts, electrical components, controls, and systems must be new and unused and be from reputable sources.

In addition, the contractor must provide the catalog cuts of major equipment items, materials list, materials manufacturers/suppliers, operations and maintenance manuals, and preventive maintenance plans.

## **Conclusions**

Based upon the results of our site visit, we reached the following conclusions for our assessment objectives. Appendix A provides details pertaining to Scope and Methodology.

1. All project components were not adequately designed prior to construction. The contractor did not provide and the government did not review the required number of design drawings for 30% and 60% submittals. The government determined the submittals reviewed were generally incomplete and inadequate. For the 90% design drawing submittals, the government concluded that the drawings were "not acceptable as 90% submittal as these drawings are incomplete, inaccurate, and substandard."

For several buildings, the 100% design drawing submittals were "rejected." In addition, the government reviewer did not sufficiently review the design submittal to realize the task order required kitchen for the dining facility was not included. Further, the contractor failed to provide quality, detailed design construction drawings. Specifically, the contractor's drawings lacked significant details, such as the rough-in and finish-out for the installation of plumbing fixtures, the need for an adequate number of cleanouts, and the use of building expansion joints. To date, the government has paid the contractor approximately \$2.6 million for its design submittals.

2. The majority of the work observed did not meet the standards of the contract and task orders. We identified significant construction deficiencies, such as poor plumbing installation, expansion cracks, concrete segregation and honeycombing, reinforcement bar exposure, and poor brickwork. In addition, the construction and equipment installation was performed at a low level of workmanship by the contractor and did not comply with the International standards required by the contract and task orders.

Construction was so poor for one facility that the contractor issued a Nonconformance Report and work was stopped while independent assessments were done to determine if the construction deficiencies could be corrected. The independent assessments determined that it would be too costly to attempt to correct the structural construction deficiencies. Even though the subcontractor agreed to “take financial responsibility for the engineering fix,” this facility was removed from the scope of work under the contract after the government paid approximately \$350,000 for the poor construction work, and it will require approximately \$100,000 to demolish the facility.

In addition, when we inspected the contractor’s rework of leaking plumbing, we discovered similar and additional plumbing deficiencies. Further, when the U.S. Army Corps of Engineers Gulf Region Central removed multiple task order requirements from the scope of work under the contract, at least two partially constructed facilities were left that pose potential safety hazards to the Baghdad Police College occupants.

3. The contractor’s Quality Control plan was sufficiently detailed, including the use of daily Quality Control reports and Nonconformance Reports to document construction deficiencies; yet the contractor’s Quality Control program implementation failed to identify significant construction deficiencies, such as poor plumbing installation practices and substandard expansion joints. Even when the Nonconformance Reports identified significant construction deficiencies, there was no assurance that corrective actions were taken. In addition, it appears the contractor did not provide the Nonconformance Reports to the government’s Contracting Officer Representative, as was required by the Quality Control plan.

The government Quality Assurance program was essentially non-existent in monitoring the contractor’s Quality Control program. Neither the U.S. Army Corps of Engineers Gulf Region Central Project Engineer nor the Quality Assurance Representative reviewed the contractor’s daily Quality Control reports. In addition, the Quality Assurance Representatives were used to track project progress and not to identify quality issues. The Quality Assurance Representatives did not identify any construction deficiencies in the daily Quality Assurance reports. Consequently, the U.S. Army Corps of Engineers was not aware of significant construction deficiencies at the project site.

The U.S. Army Corps of Engineers Gulf Region Central will receive a fee of 4 percent of the cost of both task orders for what it stated was a “limited Quality Assurance role;” which consisted of using the on-site Quality Assurance Representatives to “track progress toward” project completion instead of identifying construction deficiencies. In fact, according to U.S. Army Corps of Engineers Gulf Region Central personnel, the daily Quality Assurance reports given to the Quality Assurance Representatives did not “contain a block for quality issues.” It was the U.S. Army Corps of Engineers Gulf Region Central’s belief that the Project and Contracting Office “assumed the responsibility for project oversight and review of the

Quality Assurance Reports...” As a result, the U.S. Army Corps of Engineers Gulf Region Central will be paid approximately \$2.5 million for simply tracking the progress of the project completion instead of enforcing the procedures set for in its own guidance regarding the Quality Assurance program.

Finally, as a result of the lack of oversight and poor project management by the U.S. Army Corps of Engineers, the government paid Parsons approximately \$5.3 million in base and awards fees for substandard work.

4. Sustainability was addressed in the task order requirements, yet not adequately administered by the U.S. Army Corps of Engineers. The task order specifications required a one year warranty on all materials and workmanship for the buildings and facilities constructed or renovated in this project after issuance of the Taking-Over-Certificate. The U.S. Army Corps of Engineers Gulf Region Central used Beneficial Occupancy forms to document the date of transfer of buildings and facilities to the Baghdad Police College. However, a majority of the buildings were transferred to the Baghdad Police College without testing the adequacy and functionality of the basic utilities installed. At the time of the transfer, several buildings lacked any effort by the government to test the electrical, fire alarm, and communication systems, and plumbing for the potable and the waste water systems.

The Beneficial Occupancy forms were signed in May and June 2006, and some of the untested buildings have yet to be occupied because of the lack of power and water. Consequently, 7 months of the 12 month warranty have already passed without any testing to determine if construction deficiencies exist. Since plumbing issues are still present in the cadet barracks, we are concerned the same plumbing installation practices were done in the instructors’ barracks. In addition, since an additional power source is required to operate some of these buildings, it is possible the 12 month warranty will expire prior to even a simulated full load testing and occupancy of the buildings.

Further, this report identified what we felt to be low quality plumbing fixtures used by the contractor, which will present the Baghdad Police College with continual maintenance problems. Finally, the as-built drawings submitted by the contractor, in many cases, do not reflect the work that was actually done. Accurate information in the as-built drawings is needed for proper operations and maintenance, effective warranty enforcement, and future repair and rehabilitation work.

5. The Baghdad Police College construction and renovation project results were not consistent with the original contract and task order objectives. The contract Statement of Work called for providing the “Iraqi people with necessary basic public facilities and infrastructure with sufficient space accommodations and reliable public works, electrical, plumbing, mechanical, and communications resources that are easy to maintain, upgrade and repair...” The completed barracks buildings continue to experience significant plumbing failures; while the massive expansion cracks on the interior and exterior of the buildings will leave the Iraqis with continual maintenance issues.

In addition, this project’s construction costs were originally estimated to be approximately \$73 million. In an effort to complete the project, which was experiencing significant cost overruns and schedule slippages, 24 items had to be removed from the scope of work under the contract, such as the laundry facility, fire protection, and the communications building. In the cases of the laundry facility and the communications building, the Baghdad Police College was left with structures

51% and 38% complete, respectively; while other items, such as the driving course, connection to the power grid, and structural repairs were de-scoped with no work done at all.

The government estimates it will pay Parsons approximately \$62 million for work both fully and partially completed. Additional contracts with other contractors in excess of \$8 million have been awarded to complete some of the construction work not finished by Parsons. However, the majority of the de-scoped items, which were originally determined to be essential to a functioning police training college, will either be left as a shell (i.e. communications building) or not even attempted (i.e. driving course and fire protection). The U.S. Army Corps of Engineers has been unable to provide the original estimated costs and amount paid for each of the de-scoped items; therefore, it is not possible to determine the additional amount of funding required to complete all of the objectives of the task orders.

The Baghdad Police College construction and renovation project results were not consistent with the original contract and task order objectives because the project was poorly designed, constructed, and the contractor and the U.S. Army Corps of Engineers Gulf Region Central Project Engineer and Quality Assurance Representative did not effectively manage the project.

## **Recommendations**

We recommend that the Commanding General, Gulf Region Division:

1. Require the contractor to replace all existing plumbing fixtures and fittings in all newly constructed buildings to comply with the International Plumbing Code in accordance with contract specifications. Specifically, eliminate the use of cemented joints, abnormal fittings, and improperly sealed pipe connections. In addition, require the use of cleanouts, traps, and proper sealing techniques.
2. Require the U.S. Army Corps of Engineers Gulf Region Central Quality Assurance Representatives to be responsible for identifying quality issues as required by the contract and USACE ER 1180-1-6, instead of simply tracking project progress.
3. Require the U.S. Army Corps of Engineers Quality Assurance Representatives to become thoroughly familiar with the International Plumbing Code standards.
4. Require the U.S. Army Corps of Engineers Project Engineer and Quality Assurance Representatives to supervise the contractor's installation of all plumbing rework to ensure compliance with the International Plumbing Code.
5. Require the U.S. Army Corps of Engineers Gulf Region Division Resident Engineer to thoroughly review the contractor submitted as-built drawings. Specifically, walk through each facility and compare the as-built drawings to the actual construction completed.
6. Require the contractor to resubmit, at no cost to the government, accurate as-built drawings for any deviations noted during the walk through of the facility.
7. After completing the thorough review of the as-built drawings, verify the contractor's individual charges against the confirmed work performed. Determine if the contractor was paid for work claimed but not performed. Specifically, determine if the contractor charged, and was paid, for engineered expansion joints in the instructors' barracks. If so, then recover from the contractor the money paid.

8. Require the U.S. Army Corps of Engineers Quality Assurance Representatives to be present for any future plumbing tests. In addition, require the Quality Assurance Representatives to document the tests performed, equipment used, and test setup information.
9. Require the Project Engineer and Quality Assurance Representatives to review the 95 Nonconformance Reports submitted by Parsons for construction deficiencies and determine if corrective actions were previously taken. If corrective actions were not taken, require that necessary corrective actions be taken.

## **Management Comments**

The Gulf Region Division (GRD) generally concurred with the conclusion in the draft report. However, the GRD did not concur with all of the draft report's recommendations.

Instead, the GRD emphasized the following regarding the Baghdad Police College (BPC).

“It is important to note that the strategic and urgent need to quickly provide a training capability for the Iraqi Police has been achieved. Despite some identified shortfalls in workmanship of the sewer, water and electrical infrastructure of the facilities, not one graduation has been delayed, nor has a single class of cadets been delayed. Since June 2006, six classes, totaling about 4,000 cadets, graduated from the Baghdad Police College. Additionally, about 1,000 officer trainees are currently attending their first year of a 3-year program...Despite some identified shortfalls in workmanship of the sewer, water and electrical infrastructure of the facilities, the facilities have been turned over for use. Deficiencies noted are corrected through the use of established warranties that have enabled the government to improve those facilities already in use.”

## **Evaluation of Management Comments**

The GRD's comment regarding the ability of the BPC to graduate cadets is irrelevant to the issues raised in this report.

It is CPATT's responsibility to train, educate, and graduate cadets in a timely manner; therefore, CPATT solely is responsible for the number of cadets graduating from the BPC. GRD's lone responsibility was to ensure that the contractor provided CPATT and the BPC with a state of the art campus, including well constructed buildings with properly functioning and reliable utilities. However, GRD admits this project “does not represent a success story for construction.” In fact, statements by MNSTC-I and CPATT representatives paint a clear picture of how difficult it was for the BPC staff to deal with the numerous and continual construction deficiencies identified in this report.

For example, in August 2006, a MNSTC-I representative stated, “...the excessive delay in construction has caused significant impairment in the ability of Iraqi Security Forces to complete their mission.” In addition, a CPATT representative stated about the situation at the BPC, “...this is an urgent situation that can and is affecting the mission, if corrective action is not taken immediately we will be forced to reduce the numbers of the next basic class starting in Aug. There is not other place to house students but these dorms.”

In July 2006, a CPATT representative stated the following to a MNSTC-I representative:



*“...the most troubling part of the tour was the physical condition of the barracks...The condition of these brand new buildings are pathetic...if the buildings are not condemned by then, I strongly recommend we tour it when you come out, to see how bad construction and wasted US taxpayer dollars were combined to make unacceptable barracks...in your business I am sure you’ve seen lots of bad construction jobs – this qualifies.”*

In May 2006, the BPC water system was shut down for at least 10 days. The following statements are according to the on-site CPATT representative:

*“...when the system was turned on, within five minutes, three major leaks in the supply system were discovered. The system was shut down immediately...The BPC water supply system is not operational. It has not been operational and there is no indication that it will be operational in the next few days at the current level of interest or labor...Ten days ago, the BPC was forced to move into three of the new dorms. The BPC resisted this move until the electricity, water and sewer systems were working. There are about 1000 cadets living in the new dorms with electricity but not water or bathrooms. They are forced to walk 600-700 meters to take a shower. The students have been getting progressively more disruptive over the last ten days since the move because of the lack of water. They are frustrated that there are no bathrooms readily available, and definitely do not like the port a pots...As the students have become more and more vocal, the threat of students rioting and damage to the new buildings became a serious concern to the Dean and the BPC staff. Yesterday, the Dean indicated that if the water system was not operational by the close of business today, he would release the students for a few days to allow them to cool off and to allow the water system to be completed...The Dean decided to send the cadets home and have them return on Saturday for regular classes next week.”*

On at least two of our site visits, the BPC campus was shut down due to water system problems, causing the cadets to lose valuable classroom instruction time. In fact, on our last visit, 8 December 2006, we observed port-a-pots outside the cadet barracks. BPC representatives stated this was necessary because the water was turned off due to problems with the system and plumbing issues within the cadet barracks (Site Photo 72). During this time frame, the BPC was shut down for several days, again causing the cadets to lose valuable instruction time.



**Site Photo 72. Port-a-pots located outside the cadet barracks in December 2006**

Further, we do not agree with the GRD's assertion that the significant construction deficiencies identified throughout this report are simply "shortfalls in workmanship." The contract and task orders (TOs) specifically required the BPC construction comply with International building standards and diligent quality management by the contractor and the government. The GRD, in its comments, confirmed that International construction standards were not followed and the quality management program of the contractor and the government was not adequate. The objective of the contract and TOs was to construct and provide the BPC staff an adequate training facility, including cadet barracks and classrooms, to train a substantial number of cadets. Instead, the poor construction and thoroughly ineffective quality management forced the BPC to relocate cadets from one barracks to another. On at least one occasion classrooms were used as temporary living quarters in order to protect the cadets from leaking urine and fecal matter within the cadet barracks.

Finally, as mentioned in the Beneficial Occupancy section of the report, it is disconcerting that the GRD's comments mention that facilities with "shortfalls in workmanship of the sewer, water and electrical infrastructure...have been turned over for use" to the BPC. The GRD needed to correct all deficiencies and properly test each building prior to turn over to the BPC. However, turning the untested facilities over to the BPC only allowed the contractor to start the warranty period. For the 4 instructors' barracks buildings, the facilities have never been tested under a full load for electricity, pressurizing water lines and water flowing in sewer lines; yet 7 months of the 12 month warranty period has already expired. In addition, facilities without working fire alarm systems were turned over the immediate use to the BPC. Since the cadet barracks buildings did not comply with the required IPC standards, the continual plumbing issues put the BPC staff under tremendous pressure to constantly move cadets from building to building and caused the cadets to become unruly and miss valuable classroom instruction time.

In view of the GRD's admission that "established international standards" were not followed by the contractor and enforced by the government, we continue to believe that our recommendations are appropriate. A significant aspect to be resolved is the GRD's

insistence that the standards required by the contract and task order be ignored. We will work with the GRD to reach a mutually satisfactory resolution.

Our detailed response to the recommendations with which GRD non-concurred follows. The complete text of the GRD comments is in Appendix I.

**SIGIR Recommendation 1.** Require the contractor to replace all existing plumbing fixtures and fittings in all newly constructed buildings to comply with the International Plumbing Code in accordance with contract specifications. Specifically, eliminate the use of cemented joints, abnormal fittings, and improperly sealed pipe connections. In addition, require the use of cleanouts, traps, and proper sealing techniques.

**GRD Comments.** “Non-Concur. Task orders 6 and 29 were terminated for convenience. GRD continues to require repair of previously identified systemic problems, such as improperly connected plumbing fixtures, under warranty by working with the subcontractors. GRD will continue to staff an onsite team of field engineers to monitor warranty work and resolve warranty issues.”

**SIGIR Response.** The fact that the GRD terminated TOs 06 and 29 is immaterial. Both TOs required the contractor to comply with the IPC standards. The GRD terminated remaining contract work in May 2006 under the TOs; however, the contractor’s responsibility to comply with the terms and conditions of the contract for work performed prior to that time is not terminated. This report identified numerous instances in which the contractor failed to conform to the IPC standards. The results of not complying with IPC standards were obvious (Site Photos 73 and 74). Unless the plumbing fixtures and fittings are redone according to the IPC standards, this issue will continue to be a problem for the BPC. For example, after our previous report on the plumbing issues in the cadet barracks, the contractor “corrected” the plumbing problems (according to the GRD representatives); however, less than 2 weeks later when we visited the site, similar, if not the same, plumbing issues existed (Site Photos 75 and 76). This occurred after GRD agreed to put additional QA resources onto the warranty. Our concern is that the GRD will require the contractor to continue repairing the plumbing using practices and techniques that do not conform to the IPC standards. This will simply put a bandage on the problem and will result in perpetual plumbing issues for the BPC.

Prior to terminating both TOs, for almost two years, the GRD allowed the subcontractor to use construction techniques and practices that violated the standards identified in the TOs. Therefore, GRD cannot simply wash its hands of the plumbing issues by stating the TOs were terminated. GRD needs to initiate a comprehensive plan to correct all plumbing issues, which will involve requiring the subcontractor to replace all existing plumbing fixtures and fittings to comply with the IPC standards which they were required to comply with and for which they were paid. Our return site visits to the BPC, clearly indicates that the rework done by the subcontractor is not complying with the IPC standards and will not be a long term solution to the plumbing issues (Site Photo 77). Until the GRD enforces the contract and TO requirements of complying with the IPC standards, specifically the elimination of cemented joints, abnormal fittings, and improperly sealed pipe connections and requires the use of cleanouts, traps, and proper sealing techniques, the problems will be continual and more significant over time. According to the basic contract and GRD representatives, each warranty item is extended for one year from the date of the most recent repair. Consequently, GRD will have to decide how long it will be available for oversight in Iraq to deal with the continual warranty rework. In our opinion, with the current plumbing techniques and practices allowed by the GRD on-site engineering team, continual plumbing issues will be on going for years to come.



**Site Photo 73. Significant plumbing leaks resulting from poorly sealed pipes**



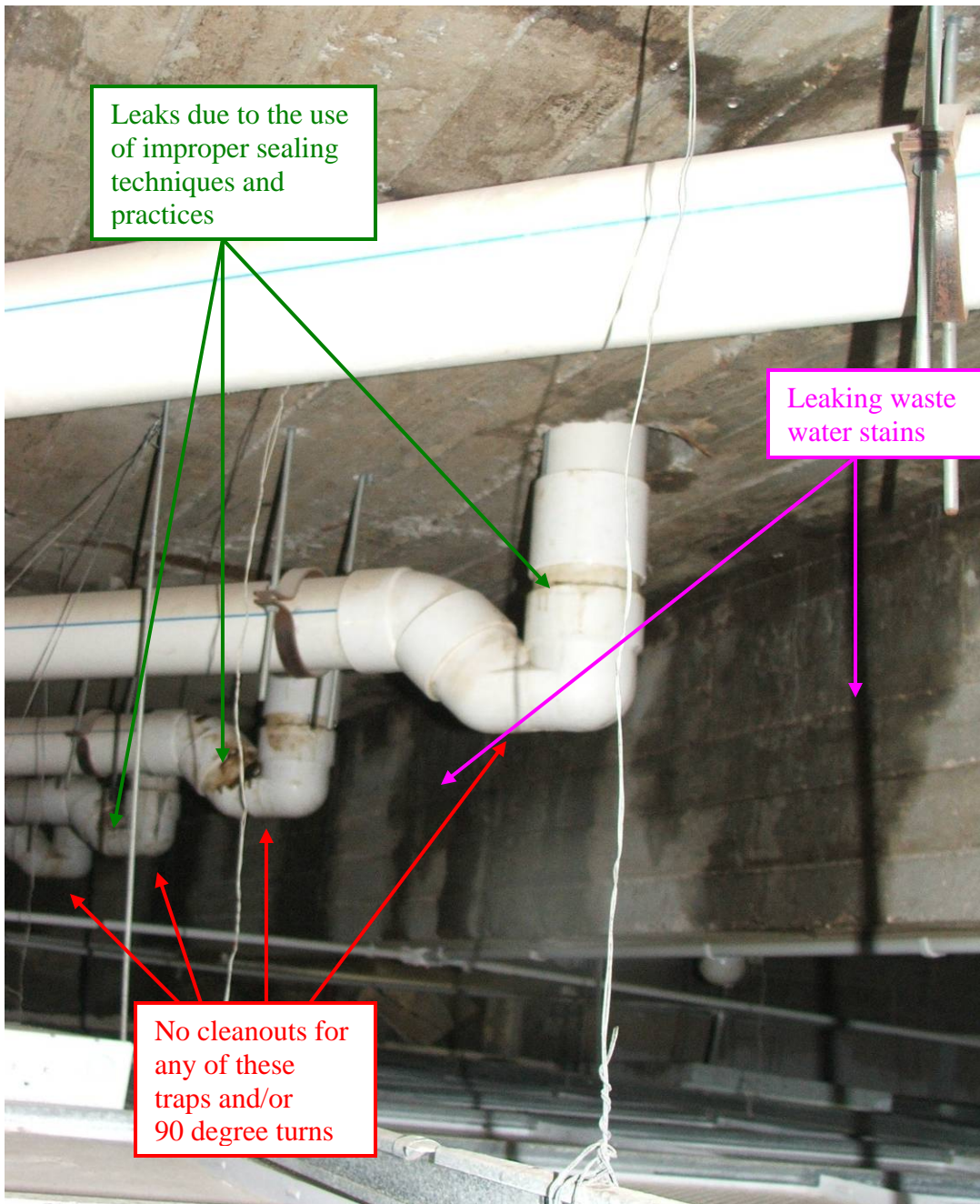
**Site Photo 74. Significant plumbing leaks resulting from poorly sealed pipes**



**Site Photo 75. Effect of leaking waste water on plumbing pipes**



**Site Photo 76. Effect of leaking waste water on plumbing pipes**



**Site Photo 77. View of plumbing for first floor toilets without cleanouts and proper sealing practices**

**SIGIR Recommendation 3.** Require the U.S. Army Corps of Engineers Quality Assurance Representatives to become thoroughly familiar with the International Plumbing Code standards.

**GRD Comments.** “Non-Concur. In accordance with ER 1180-1-6, the contractor is responsible for all activities necessary to manage, control and document work to ensure compliance with the contract plans and specifications. The USACE QAR is responsible for implementing and enforcing the activities specified in ER 1180-1-6, paragraph 7.c. Quality assurance representatives should understand the design requirements. To validate the contractor’s work, the quality assurance representative will review the

contractor's quality control program to ensure the contractor uses competent personnel and conducts proper testing.”

**SIGIR Response.** We do not understand why GRD disagrees with the need to educate its LN QARs on the standards of the IPC – the standards specifically required by the contract and TOs. Without any knowledge of IPC standards, the QARs will not have the ability to identify, document, and correct contract non-compliance resulting in plumbing deficiencies. ER 1180-1-6 also states that “subsequent to CQC completion inspections, acceptance inspections of completed construction are a government responsibility.” The government will not be able to properly inspect completed work if those individuals responsible (i.e. QARs) do not have the technical knowledge. It is imperative for the QARs to have a thorough knowledge of the IPC as well as the other standards required under the contract; otherwise, the contractor will continue the use of cemented joints, abnormal fittings, and improperly seal pipe connections.

In addition, ER 1180-1-6 states that the QAR must “ensure that new work is not placed on unacceptable work or that progress payments do not include the value of non-conforming construction.” It is obvious from the numerous examples identified throughout this report that the contractor was paid for non-conforming construction. This will not change until the QARs are educated on the codes and standards required by the contract and TOs.

Further, the GRD's statement that the QARs should only “understand the design requirements” is confusing because without having a thorough understanding of the standards for which the contract and TOs are based, the QAR will be unable to determine if the design requirements meet the standards of the contract and TO. For instance, during our second site visit on 4 September 2006, the subcontractor was in the process of tearing up the bathroom floors and replacing the original plumbing. We witnessed the replacement of the original floor drain fixture with a new fixture; however, the subcontractor continued to use improper sealing techniques. Originally the subcontractor appeared to use brown paper and jute bags to seal the floor drain (Site Photo 78); while for the rework the subcontractor used a rock to help seal the floor drain instead of using IPC approved sealing techniques and practices (Site Photo 79). The GRD QARs allowed this improper construction practice because apparently the QAR is not thoroughly familiar with the IPC standards.



**Site Photo 78. Example of poor sealing technique used by the contractor during initial construction**



**Site Photo 79. Example of poor sealing technique used by the contractor during rework construction**

**SIGIR Recommendation 4.** Require the U.S. Army Corps of Engineers Project Engineer and Quality Assurance Representatives to supervise the contractor's installation of all plumbing rework to ensure compliance with the International Plumbing Code.

**GRD Comments.** "Non-Concur. The contractor is responsible for all contract work. In accordance with ER 1180-1-6, the contractor is responsible for all activities necessary to manage, control and document work to ensure compliance with the contract plans and specifications. The USACE QAR is responsible for implementing and enforcing



activities specified in ER 1180-1-6, paragraph 7.c. The GRD onsite engineering team will observe the sub-contractor's installation of plumbing rework to be accomplished under existing warranties to ensure compliance with the contract plans and specifications. As site visits are completed, the quality assurance representatives will document their observations on daily quality assurance reports."

**SIGIR Response.** We believe the GRD on-site engineering team needs to do more than just "observe" the subcontractor's installation of plumbing rework. The QAR is required to inspect, document, and ensure the correction of construction work that does not meet the contract and/or TO requirements. The subcontractor previously completed rework of the plumbing issues in the cadet barracks, which we inspected in November and December 2006. The GRD on-site engineering team did not identify, document, and correct the problems we observed in the cadet barracks (Site Photos 80 and 81). This rework obviously was not in compliance with "contract plans and specifications." Therefore, we believe it to be unlikely that future rework by the subcontractor will be done in accordance with the contract plans, specifications, standards and construction codes. The solution to this issue is to educate the QARs on the IPC standards and then have the QARs play an active role in overseeing the subcontractor's work.

GRD stated that the QAR is responsible for implementing and enforcing the activities specified in ER 1180-1-6. ER 1180-1-6 states that the QAR must "conduct government QA tests at the job-site to assure acceptability of the completed work." The end result of the QA process is to assure "end product quality." It is obvious from the numerous examples identified throughout this report that the government and the BPC did not receive "end product quality."

Finally, ER 1180-1-6 states that one of the government's responsibilities is "enforcement of contract clauses." In view of the GRD's admission that "established international standards" were not followed by the contractor and enforced by the government, we conclude the GRD QARs did not comply with ER 1180-1-6.



**Site Photo 80. Leaking waste water from poorly sealed pipes**



**Site Photo 81. Enlarged view of Site Photo 80**

**SIGIR Recommendation 6.** Require the contractor to resubmit, at no cost to the government, accurate as-built drawings for any deviations noted during the walk through of the facility.

**GRD Comments.** “Non-Concur. Under a cost plus contract, the U.S. government cannot legally require the contractor to resubmit drawings at no cost. In response to previous requests, the prime contractor has refused to resubmit as-built drawings without receiving additional funds for this work. There are no additional funds for this project.”

**SIGIR Response.** According to USACE ER 415-345-38, “customers must have complete, accurate and timely as-built information for proper operations and maintenance, effective warranty enforcement, and future repair and rehabilitation work.”

Further, the GRD does not address the fact that it was their responsibility to verify the accuracy of the contractor submitted as-built drawings. From our review of the available as-built drawings, it is apparent these were not complete or accurate drawings. In addition, GRD’s own assessment concluded that the as-built drawings often did not match the existing field conditions. Since the GRD failed to require the contractor provide complete and accurate as-built drawings, GRD cannot leave the BPC without critical documentation for warranty issues.

In addition, the GRD allowed the contractor to have significant cost overruns which apparently resulted in no additional funding being available. However, this project was originally budgeted at approximately \$73 million (prior to termination), but according to GRD representatives, the cost at termination was approximately \$62 million. Therefore, additional funding should be available to perform this critical service to the customer.

Regardless of the contract instrument used for this project, the GRD is responsible for providing the end user, the BPC, with accurate and detailed as-built drawings.

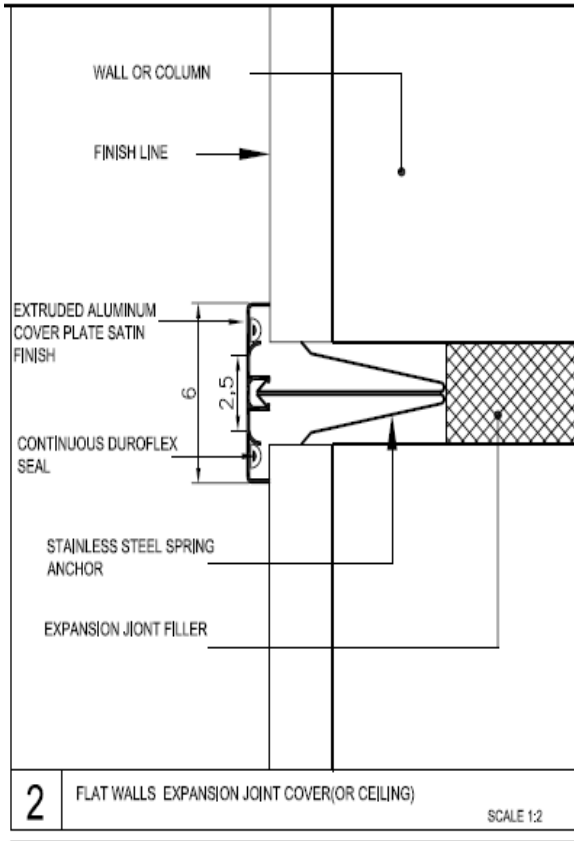
**SIGIR Recommendation 7.** After completing the thorough review of the as-built drawings, verify the contractor's individual charges against the confirmed work performed. Determine if the contractor was paid for work claimed but not performed. Specifically, determine if the contractor charged, and was paid, for engineered expansion joints in the instructors' barracks. If so, then recover the money paid from the contractor.

**GRD Comments.** "The recommendation, as stated, would not work as the prime contract was a cost reimbursable contract and its subcontracts were firm-fixed-price. It is not a standard contractor billing practice to prepare detailed invoices for firm-fixed-price contracts; therefore, the government would not get this detail from the prime contractor on its subcontractor portion of their invoices. GRD completed a review of available contractor invoices and found that costs are billed in lump sum amounts for each type of cost submitted on the invoice. Based on these facts, the Gulf Region Division recommends that SIGIR withdraw this recommendation. Otherwise, GRD non-concurs because the contractor was not required to invoice the U.S. Government (USG) at a level of detail that would enable the USG to determine if the contractor charged, and was paid, for specific construction tasks."

"The Gulf Region Division has coordinated with DCAA to conduct an audit of Parsons accounting and purchasing records to enable the USG to determine if the contractor was paid for work not performed. Based on DCAA's final report the USG will take appropriate action."

**SIGIR Response.** In view of the GRD's admission that they do not know if the contractor was paid for work not performed, we continue to believe that our recommendation is appropriate.

The contractor's as-built drawings, in our opinion and in GRD's own assessment, are not complete and accurate. For example, the as-built drawings for the instructors' barracks buildings show a very specific prefabricated joint system (Figure 9). We found little or no evidence of designed joints in place to protect the building from vertical and horizontal movement. Not only did the instructors' barracks suffer from significant interior and exterior expansion cracks (Site Photos 82 and 83) and runs the risk of reducing the buildings' life expectancy, equally troubling is the fact the GRD does not know if the contractor was paid for installing the prefabricated joint system claimed in the as-built drawings. The government already paid Parsons for inaccurate as-built drawings (since the as-built drawings reference prefabricated expansion joints which are not present on the buildings) and quite possibly paid Parsons for the installation of the prefabricated joint system.



**Figure 9. Contractor's as-built drawing**



**Site Photo 82. Exterior expansion crack**



**Site Photo 83. Substantial exterior expansion crack**

The fact that the contractor was “not required to invoice the U.S. Government (USG) at a level of detail that would enable the USG to determine if the contractor, charged, and was paid, for specific construction tasks” is irrelevant. We have identified a case where either the as-built drawings are not accurate or the contractor was paid for work not performed. DCAA individually will not be able to determine if the contractor was paid for work not performed, since the DCAA will not have access to the as-built drawings or be able to verify the field conditions.

As mentioned earlier in this report, PCO CN-107 “Process Construction Interim Payments (Cost Plus),” required the PCO and GRD staffs to review interim invoices for cost reimbursable TOs to ensure costs are “reasonable, allocable, and allowable...” However, according to the GRD representatives, the amount paid for any specific construction task is not available because “these amounts are tracked in aggregate for several structures and/or systems.” For instance, GRD records only indicate that approximately \$11.2 million and \$4.4 million was paid for the 8 cadet barracks buildings and 4 instructors’ barracks buildings, respectively; the breakdown of those costs are not available. In addition, the GRC Resident and Project Engineers and QARs are not reviewing the contractor invoices prior to payment. We have concerns with this approach to project management.

First, our concern with the GRC Resident or Project Engineer and QAR not reviewing contractor invoices prior to payment is that the contractor is being paid for work that does not meet the contract’s requirements. During the course of our site visit, we observed several instances of construction work which did not meet the contract’s requirements; however, the contractor received payment for this non-compliant work since the USACE Finance Center Millington did not request the GRC Resident or Project Engineers or the QAR responsible for the BPC to review and approve the invoices. For example, Parsons submitted invoices and was paid \$348,332 for the laundry facility; however, the construction deficiencies associated with the laundry facility are so significant and potentially hazardous that the MNSTC-I has decided it is safer and more cost effective to spend approximately \$100,000 demolishing the structure and to contract to have another laundry facility built.

Also, we are concerned that the contractor may be paid for work not performed. The only way to prevent this from happening is reviewing detailed invoices. If the GRC Resident or Project Engineer performed this review, there would be no uncertainty in whether or not the contractor was paid for the prefabricated expansion joints claimed in the as-built drawings but missing from the four instructors’ barracks buildings. Another example of the problem with not requiring and reviewing detailed invoices is the BPC’s security office building. According to the BPC representatives and the Iraqi BPC security representative, the contractor rehabilitated the building’s interior and exterior; however, according to the GRD representatives, “we can’t find any evidence in the SOW or the contract that Parsons would have done any work on that building... We did hear a rumor that Parsons may have done some work on the sewer system in the building, but if they did, they never told anyone or, as far as we can tell, billed anyone to do it.”

BPC representatives stated it was rehabilitated because it did not look similar to the other existing buildings at the BPC. Site Photos 84 and 85 show typical existing BPC buildings; while Site Photo 86 shows the exterior of the security office. We visited the security office and it appears to have been rehabilitated on the interior and exterior (Site Photos 87 and 88). Site Photos 89 and 90 show significant damage to the building’s exterior and sidewalk and large amounts of standing sewer water. However, as a result of not requiring and reviewing detailed contractor invoices, it is unknown what construction/rehabilitation the contractor allegedly performed on this building, which will

impede any efforts to determine if the contractor is responsible for warranty repairs of the exterior or the sewer system. In addition, the GRD representatives do not know the amount Parsons was paid for this work. According to the GRD representative, "...based on my dealings with Parsons, I assess the probability of them doing anything at no cost to be somewhere on the low side of infinitesimal."



**Site Photo 84. Example of typical existing BPC building exterior**



**Site Photo 85. Example of typical existing BPC building exterior**



**Site Photo 86. Front view of the BPC security office**



**Site Photo 87. Renovated interior of BPC security office**



**Site Photo 88. New bathroom tile with the BPC security office**



**Site Photo 89. Substantial cracks in the exterior of the building and side walk**



**Site Photo 90. Significant standing sewer water outside the BPC security office**

**SIGIR Recommendation 8.** Require the U.S. Army Corps of Engineers Quality Assurance Representatives to be present for any future plumbing tests. In addition, require the Quality Assurance Representatives to document the tests performed, equipment used, and test setup information.

**GRD Comments.** “Non-Concur. In accordance with ER 1180-1-6, the contractor is responsible for all activities necessary to manage, control and document work so as to



ensure compliance with the contract plans and specifications. The USACE QAR is responsible for implementing and enforcing activities specified in ER 1180-1-6, paragraph 7.c. GRD will ensure that the subcontractor gives sufficient notice of future plumbing tests so that GRD can arrange for a quality assurance representative to witness the test and verify the test results. Quality assurance representatives will document their observations made during site visits on daily quality assurance reports.”

**SIGIR Response.** It is unclear why the GRD non-concurred with the recommendation, considering their response agrees with our recommendation - that the QARs will be present to witness and verify test results. ER 1180-1-6 states that the QAR will “verify adequacy and calibration of test equipment, application of specified test standards and computation of test results.” We do want to emphasize that the QAR needs to document the tests performed, equipment used, and test setup information. In addition, the QAR should provide photographs of the testing in progress. This is particularly important considering GRD previously concluded that “a deficiency we’ve discovered during our ongoing assessment of our activities at the BPC is that no formal documentation of our testing was generated.”

### **Gulf Region Division Comments on Specific SIGIR Statements.**

**SIGIR Statement.** Pages 8-10, “Design and Specification Review Process.”

Page 8, Paragraph 2. “However, the PCO did not have a submittal process in place to review Parsons’ designs.”

Paragraph 3, “The PCO representative also stated that he was...concerned the drawings are not accurate.”

Paragraph 5, “Also on 10 January 2005, the government reviewer commented that the electrical drawings for the motor pool were not complete.”

Page 10, Paragraph 1, “Further when drawings were submitted, they were largely rejected by the PCO for being incomplete, inaccurate, and substandard.”

Paragraph 3, “...as-built drawings provided for water distribution do not match the existing field conditions in terms of location, construction and materials.”

Paragraph 4, “The contractor’s drawings lacked significant and basic design details, such as the rough-in and finish-out for the installation of plumbing fixtures...”

Paragraph 4, “Further, there was a significant omission with regards to the location and correct type of building expansion joints.”

**GRD Comments.** “The design-build concept allows contractors to provide an experienced design and construction team including Quality Control staff. It is the responsibility of the contractor to provide adequate designs. With the Baghdad Police College, the design-build contractor failed in the design responsibilities by routinely submitting incomplete drawings, which government reviewers returned. Typically, the design-build contractor did not address these comments. Furthermore, with the overreaching emphasis on construction progress, design-build construction was ongoing while the contractor was unresponsive in providing timely and complete design submittals.”

**SIGIR Response.** We agree that it is the contractor's responsibility to provide adequate designs; however, it is also the government's responsibility to require the contractor provide all the necessary submittals and review the contractor's design submittals for accuracy and completeness in a timely manner.

The PCO did not have a submittal process in place to review the contractor's designs. The need for a standardized submittal process was originally discussed in September 2004, even though the project was awarded in May 2004 and construction began in July 2004. The contractor's representative replied that it was the "...risk Parsons is willing to take to expedite having the work begin." This occurred even though a PCO representative was "...concerned the drawings are not accurate."

The lack of a design and specification submittal process resulted in the government not requiring the contractor provide the necessary design drawings and not reviewing all the submitted design drawings.

The government only reviewed a portion of the submitted 60% and 90% design submittals and found the majority of the drawings to be incomplete and lacking information. The government did reject several design submittals; however, the government did not follow up with the contractor for corrected submittals. The contractor submitted 100% complete designs to the PCO. This design was reviewed and rejected by the government for the electrical section for the motor pool and ablution unit buildings. There is no indication that the contractor ever updated the 100% design drawings with the reviewer's comments and resubmitted them to the PCO for review.

In addition, the government allowed construction to continue from July 2004 through June 2005 even though the contractor had not provided the required number of complete design drawing submissions. Further, when drawings were submitted, they were largely rejected by the PCO for being incomplete, inaccurate, and substandard.

While the government's reviews generally identified poor electrical design drawings by the contractor, there was no mention about the absence of quality, detailed design construction drawings. It is customary to show construction detail for individual items as well as typical details for items or components used at multiple locations. All construction detail shows the material, method, and critical dimensions to perform the task for the benefit of the installer. The contractor's drawings lacked significant and basic design details, such as the rough-in and finish-out for the installation of plumbing fixtures (a riser diagram for both fresh water and soil piping) and the need for an adequate number of cleanouts and traps. Further, there was a significant omission with regards to the location and correct type of building expansion joints.

Detailed design drawings for the rough-in and finish-out of the plumbing fixtures were not provided by the contractor. Instead the drawings were generic and did not specify the distance that the hot and cold water lines should extend beyond the wall (i.e. rough-in) for the plumber to connect to the shower faucet and head (Figure 10). In addition, the drawings do not provide an enlargement of one shower as an example to provide specific installation details, such as the type of plumbing fixtures to use (i.e. finish-out). Without detailed design drawings, the subcontractor does not have adequate guidance to properly install the water lines and plumbing fixtures.

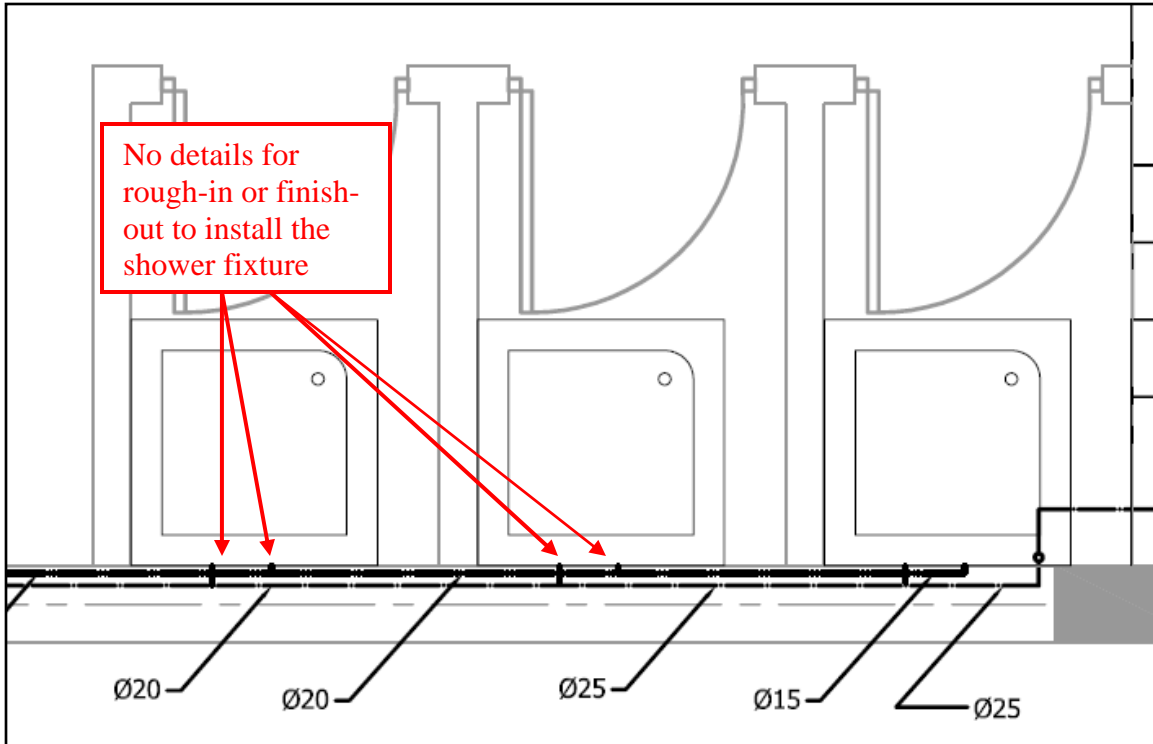


Figure 10. Contractor design for installation of hot and cold water lines for cadet barracks showers

Finally, the contractor complained its submittals were not evaluated in a timely manner by the government. Specifically, the contractor stated the following:

*“I’ve been instructed by PCO that any delays on approving the submittals by the GRC exceeding 24 hours is unacceptable. In the same regard, I gave the remaining submittals to the PCO for approval due to the delays that sometimes exceeded 15 days.”*

It appears the government was more concerned with construction progress than with construction quality.

**SIGIR Statement.** Page 24, “Inexplicably, GRD did not pursue the recovery of costs incurred for the partially completed central laundry facility, even though the subcontractor accepted responsibility for the poor construction. GRD did not seek the return of \$348,332 paid to Parsons for this structure.”

**GRD Comments.** “Under a cost-plus contract, the government bears the cost of work, regardless of degree of completion of a project. The government reduced the rate of expenditure of project funds by de-scoping the central laundry facility thereby reducing costs the government would have been responsible for under the Parsons cost-plus contract and freeing up funds for the remainder of the project. GRD was unable to recover costs incurred for the partially completed central laundry facility because, under a cost-plus contract, the government is liable for incurred costs unless the contractor commits fraud, intentionally disregards contract requirements, or was grossly negligent.”

**SIGIR Response.** In our opinion, the subcontractor’s construction of the central laundry facility was so egregious that it blatantly disregarded contract requirements. The contract and TOs required the construction be in compliance with the International Building Code

standards. The construction techniques and practices used for the central laundry facility do not appear to conform to any established International standard (Site Photos 91-94).

In addition, the USACE stated that the “Government reduced the rate of project expenditure of project funds by de-scoping the central laundry facility thereby reducing costs the Government would have been responsible for under the Parsons cost-plus contract and freeing up funds for the remainder of the project.” This comment fails to mention that the USACE QAR did not identify any of the obvious construction deficiencies (Site Photos 91-94). According to the USACE GRC personnel, the QARs were only to track project progress and not comment on any construction deficiencies. Parsons QC engineer identified the poor construction work in October 2005 and completed a NCR. On 24 October 2005, Parsons notified the USACE of its concerns with the central laundry facility. Since this project started on 1 February 2005, it means the USACE did not notice or document any construction deficiencies for this facility for over 8 months prior to being notified by Parsons. GRD representatives advised us that in order for the government to require the contractor demolish the facility, it must be considered an “imminent danger.” GRD representatives stated the central laundry facility is not an imminent danger because a “potential” resolution to the construction deficiencies was agreed to but was considered too costly and timely to complete. However, the potential resolution was disputed within GRD. For example, a response to the proposed retrofit of the central laundry facility stated “in summary, the proposed retrofit for the Central Laundry is not acceptable for structural, constructability, and safety reasons.” In an email, a GRD representative stated the following:

*“The quality of the existing beam was so bad that we did not have any confidence in it. The fix that everyone agreed to was to completely ignore the strength of the existing beam, and the encasement beam was designed to take the original live load, original dead load, and the dead load of the bad beam...These beams are BAD!”*

In addition, Parsons, in December 2006, stated that the subcontractor “made no valid effort to rectify the deficiencies in an acceptable manner and have left a facility that is structurally unsafe and as a result must be demolished.”

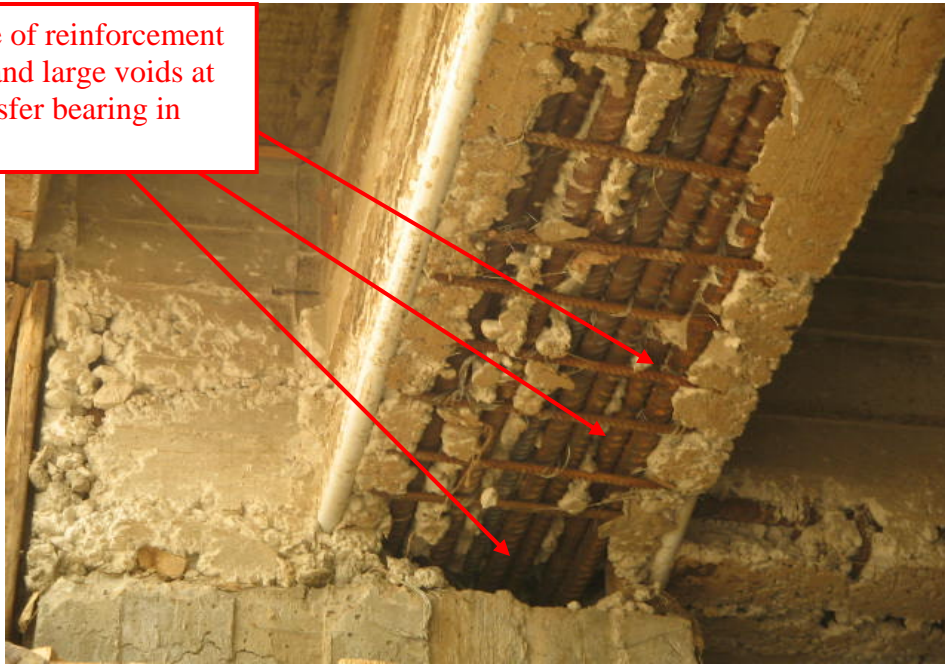
Besides the subcontractor’s obvious deviations from International standards, the other causes are poor QC and QA oversight. While Parsons only recognized the construction deficiencies after approximately 8 months, the USACE QARs never identified the blatant construction deficiencies. GRD paid Parsons \$348,222 for this partially completed, deficiency filled facility. However, if Parsons had not brought the obvious construction deficiencies to the USACE’s attention in October 2005, the USACE would have continued to pay for substandard work, since its QARs were not required to identify any construction deficiencies.

The construction work was so obviously deficient that the subcontractor even accepted responsibility for it. In an internal GRD document, it stated the following:

*[The local Iraqi subcontractor] indicated their acceptance of contractual liability and confirmed responsibility to conduct repair and/or replacement as directed...As noted above, the subcontractor agreed that they would take financial responsibility for the engineering fix...”*

Since the subcontractor admitted contractual and financial responsibility for the obvious poor construction, we do not understand why the USACE decided to de-scope the central laundry facility without requiring financial recovery from the subcontractor.

Evidence of reinforcement bar rust and large voids at load transfer bearing in column

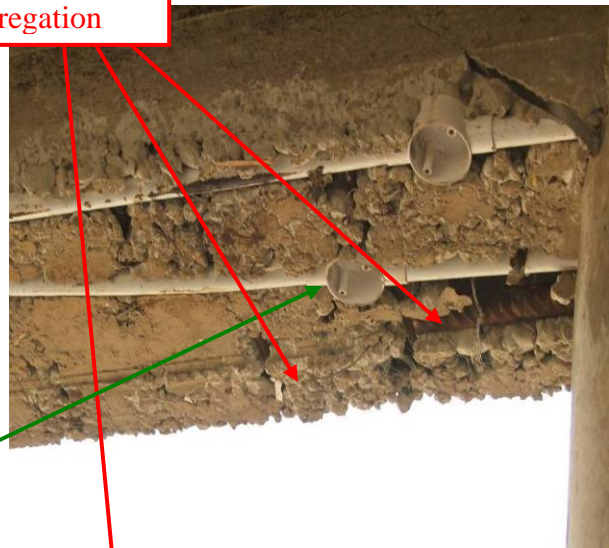


Site Photo 91. Construction deficiencies within the central laundry facility

Areas of honeycombing, voids, and segregation



Site Photo 92. Concrete segregation and electrical conduit exposure



Site Photo 93. Concrete segregation and electrical conduit exposure

Electrical conduit exposure



Site Photo 94. Concrete voids and electrical conduit exposure

**SIGIR Statement.** Page 33, first paragraph after bulleted list: “GRD and Parsons representatives believed a building without an operating fire alarm system was acceptable for turnover to the BPC and ready for occupancy by the cadets.”

**GRD Comments.** “It is not GRD’s policy to turn over buildings without functioning fire alarm system[s]. Furthermore, there is no basis for SIGIR’s statement since GRD identified the deficiency in a punch list.”

**SIGIR Response.** GRD’s official policy may be to not turn over a building without a functioning fire alarm system, but this is exactly what was done. According to the Beneficial Occupancy forms for Classrooms E and G, punch list items of the “fire alarm system is not working” were identified. In fact, for Classroom E, signed 27 May 2006, not only did the punch list state the “fire alarm system is not working,” but also stated that “the building could be occupied by cadets tomorrow.” To date, even though the non-working fire alarm system was listed as a “punch list” item, according to BPC representatives, it has not been corrected and cadets have occupied the rooms for several months.

**SIGIR Statement** Page 66, “Base and Award Fees”, Paragraph 2, “The Award Fee Board has not met for this time period [September 2005-September 2006].”

**GRD Comments.** “This statement is inaccurate. On 3 May 2006, the Awards Fee Board presented its recommendations to the Award Fee Determining Official to discuss the performance period September 2005 through March 2006. No award fee was given [to] the contractor for any task order during that period. More specifically, Task Orders 6 and 29 were not eligible for award fee during this period based on [a] lack of progress at the Baghdad Police College. The Award Fee Board has not yet met for the period after March 2006.”

**SIGIR Response.** We corrected this in the final report. However, during the 11 September 2006 meeting with GRD, GRC, BPC, MNSTC-I, and SIGIR personnel, we requested all documentation related to contractor award fees and contractor performance. GRD personnel provided us all of its documentation, which did not include any recommendations to the Award Fee Determining Office for the performance period September 2005 through March 2006.

**SIGIR Statement.** Page 119, Appendix E, “Work in Progress/Work Partially Completed”: “Parsons’ original design drawings did not include the ‘attached’ kitchen required by the TO.”

**GRD Comments.** “A kitchen was never part of the design for the 1,500 cadet dining facility. The contractor’s Rough Order of Magnitude submittal, dated 26 May 2004, states that a ‘dining hall shall attach to a new kitchen’ and the ‘existing music hall shall become new commercial grade kitchen...renovated under separate contract’. In addition, the government’s technical evaluation, dated 24 October 2006, states ‘connect kitchen to existing dining hall’ and describes requirements as a structure of no more than 25 to 35 feet, basically a corridor from one point to the other. In summary, the dining facility was to connect to a kitchen renovation under a separate contract. This functioning kitchen currently exists in a building almost adjacent to the new dining facility.”

**SIGIR Response.** TO 06 required the existing music hall (Building BF) become the new commercial grade kitchen and the new dining hall attach to this new kitchen. The contractor’s Rough Order of Magnitude (ROM), which according to GRD excluded the attachment of the dining facility to the kitchen, should have been rejected by the government for not complying with the TO requirements. In addition, the government’s

Technical Evaluation does not mention the contractor's ROM statement that the new commercial kitchen would be "renovated under separate contract," considering this would require additional funding on the part of the government. Further, it does not make sense why the contractor's ROM stated the new commercial kitchen would be "renovated under separate contract," since it was specifically included in the TO. We could not locate any contract or TO modification which eliminated the requirement for a kitchen.

Currently, according to BPC representatives, the cadets are being fed using a previously existing BPC kitchen and dine in an existing BPC facility. When the new dining facility is completed, a BPC representative stated the existing kitchen will be approximately 50 yards from the rear of the new dining facility. In fact, BPC representatives told us in November 2006 that GRD personnel were "embarrassed" when they realized the new dining facility did not have an attached kitchen and would try to obtain funding under another contract to construct a kitchen.

**SIGIR Statement** Page 127 - 131, Appendix G, "Work Completed Since Initial Site Visit" versus completed work.

**GRD Comments.** "GRD repaired under warranty all items previously identified but has discovered some items requiring re-work.

GRD has directed and overseen the replacement of the sewage and drainage systems in the restrooms of all cadet barracks buildings. These repairs included cleaning or replacing stained light fixtures and ceiling tiles, as well as, re-pouring, waterproofing and retiling the concrete floors after repairing or replacing affected piping. In some instances, GRD discovered areas requiring rework due to failed pipe joints allowing leakage from the drain system. The subcontractors repaired the identified leaks. Since the Baghdad Police College's occupancy and use of the facilities, additional repairs have been identified which are outside the scope of warranty.

Based on captions provided by SIGIR, the orientation of SIGIR's photos and the inability of inspection teams to locate similarly stained or wetted fixtures on the water closet side of any barracks restroom during three comprehensive walkthroughs conducted in November and December 2006, it appears the light fixtures identified in site photos 181, 182, and 183<sup>8</sup> are located on the shower side of the second floor restroom. Because of the arrangement of wastewater piping in the restrooms, there is no piping above the showers from which sewage can leak. A team of engineers from the Ministry of Interior, in the presence of representatives from Multi National Security Transition Command – Iraq and GRD, qualitatively determined that yellow liquid present in light fixtures of cadet barracks restrooms did not consist of urine and fecal matter, but was actually dirt-filled fresh water. Further, based on inspection of representative fixtures, these engineers also believe the crystallized deposits shown in photo 181 are salt deposits from fresh water leaking through the concrete floor above."

**SIGIR Response.** As we stated in Appendix G of this report, we visited the BPC on 10 November 2006 to verify the work accomplished at the cadet barracks buildings. This was done in response to GRD representatives telling us that the subcontractor had dug up the concrete, replaced the poorly installed plumbing, finished the floors for the cadet barracks buildings, and cadets were occupying the buildings. We found similar problems

---

<sup>8</sup> Site Photos 181-183 referred to by GRD are for the draft report; which correspond to Site Photos 212-214 of this report.

during this site visit as we did in our earlier site visits, such as water leaking from the ceiling. In addition, we noticed leaking waste water in the same location on the pipes (Site Photos 95 and 96). It is apparent that the subcontractor did not properly connect the pipes together, which allowed waste water to drain on the outside of the pipes.



**Site Photo 95. Effect of leaking waste water on plumbing pipes**



**Site Photo 96. Effect of leaking waste water on plumbing pipes**

GRD stated that “in some instances, GRD discovered areas requiring rework due to failed pipe joints allowing leakage from the drain system.” As mentioned earlier, the leakage



resulted from the improper connection and sealing of the pipes together. The rework done by the subcontractor did not eliminate the plumbing issues because the GRD allowed the subcontractor to not comply with the IPC standards. Until the GRD requires the subcontractor to follow the IPC standards, these plumbing issues will be a continual problem for the BPC.

With regards to GRD's assertion that we misjudged urine and fecal matter for dirt filled fresh water within multiple light fixtures, the comment contradicts an earlier GRD explanation of the problem. On 1 December 2006, a GRD representative stated that a leak in the sewer line "resulted in sewage leaking into the false ceiling above the restroom on the 2<sup>nd</sup> floor. The sewage spread across the ceiling, dripping through the metal ceiling tiles in places, and accumulating in the light fixtures at the lowest points of the ceiling." Therefore, according to GRD representatives, the sewage collection came from the water closet on the other side of the room.

Upon close examination of multiple light fixtures in November 2006, the substance we saw (Site Photo 97) appeared to be quite similar in appearance to the urine and fecal matter we witnessed in our initial site visit (Site Photo 98). In addition, the GRD comments do not address the substance on the outside of the light fixtures. Again, this substance appears to be very similar to the substance we witnessed on the outside of the lighting fixtures on our first site visit.

Further, even if GRD is correct that it is not urine and fecal matter within the light fixture, the fact that the substance is only "dirt-filled fresh water" is still extremely problematic. The large collection of liquid within the light fixture certifies a significant plumbing problem, regardless of whether the substance is urine and fecal matter or fresh water. Site Photo 99 shows just how "dirty" the fresh water at the BPC is. There is no explanation from GRD regarding how this "fresh water" became so "dirt-filled." Either the BPC is providing dirty fresh water for the cadets to use or the water has become contaminated in the distribution system.

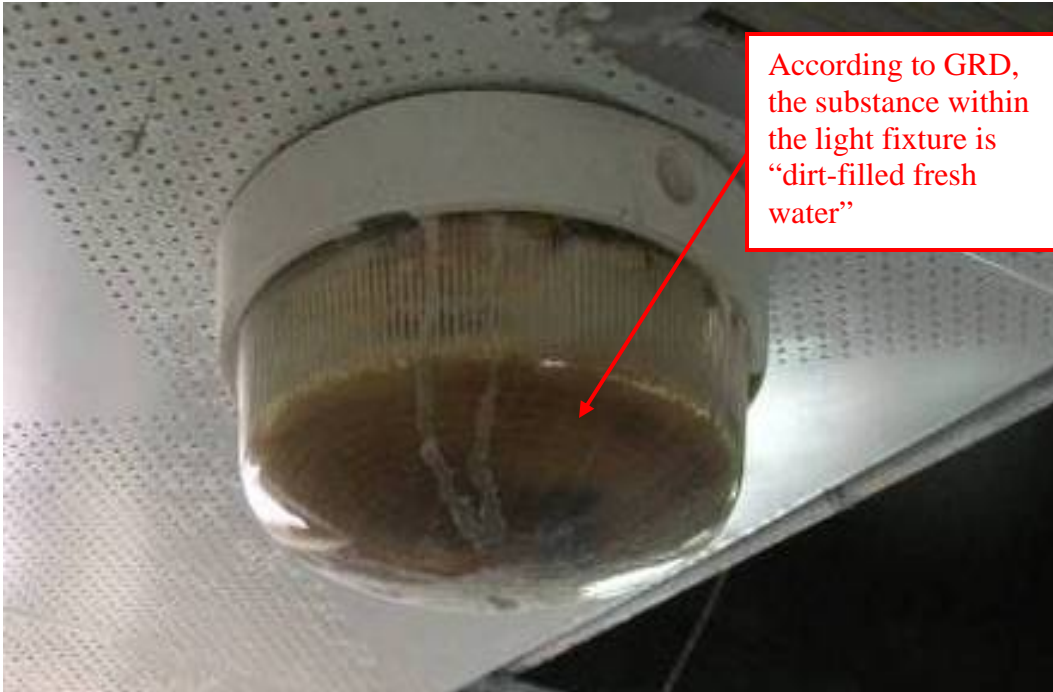
Whether the liquid substance is urine and fecal matter or "dirt-filled fresh water," GRD needs to realize that the plumbing system is not only tremendously flawed, but the cadets may be supplied with hazardous water. We continue to believe that GRD needs to deal with the more important issue of the continual problems arising from poor construction techniques.



**Site Photo 97. Urine-filled light fixture in cadet barracks bathroom after rework**



**Site Photo 98. Urine-filled light fixture in cadet barracks bathroom from original construction**



According to GRD, the substance within the light fixture is “dirt-filled fresh water”

**Site Photo 99. Light fixture with the cadet barracks bathroom (November 2006)**

Finally, we do not find any validity to GRD’s claim that the “crystallized deposits shown in photo 181 are salt deposits from fresh water leaking through the concrete floor above.” First of all, when comparing a current photo (Site Photo 101) of the ceiling panel damage to a photo from our original site visit, which the GRD concurred was crystallized urine deposits (Site Photo 100), the damage appears to be identical. It must be noted that the damage in the original site visit photo is more substantial because the plumbing issues had been on going for several months, while the damage from November 2006 occurred in the “reworked/repared” plumbing that had only been used for a few weeks.

In addition, we do not believe the “fresh water” at the BPC contains the amount of salt that would result in the damage to the ceiling panel (Site Photo 102). In our estimation, in order for that significant amount of salt deposit damage, the BPC “fresh water” must have the same salt concentration as ocean water. BPC representatives, who have lived on site for several months, stated they have not noticed a strong salt consistency within the water they use for showers, sinks, and toilets. In fact, the BPC representatives stated that the BPC receives the same “fresh water” from the city of Baghdad that the International Zone residents also use for showers, sinks, and toilets.

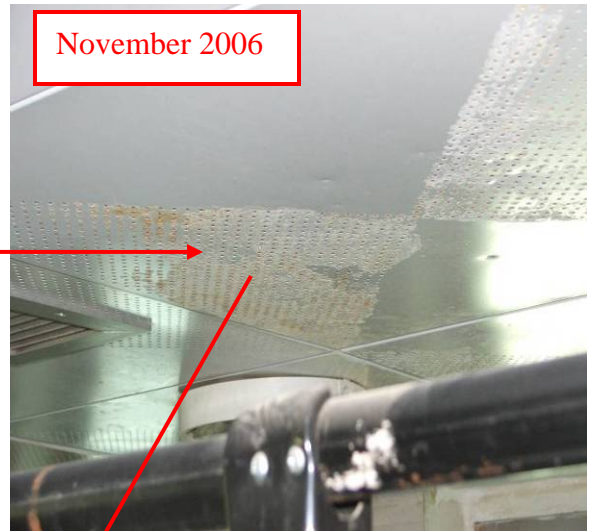
We requested any testing and chemical analysis of either the ceiling panels or the “fresh water” when making their determination the damage was salt deposits. GRD responded that “there is no lab analysis for either material” (the claim of dirt filled fresh water in the light fixture and the damaged ceiling panels were salt deposits). GRD further stated the observations of the MOI, MNSTC-I, and GRD “were not formally documented.” Instead “GRD was originally informed that a MNSTC-I representative was going to send a sample of the liquid to a laboratory for testing. Later, GRD found that the sample had not been sent for chemical analysis.” Without any testing or chemical analysis performed, GRD cannot definitively state that the substance in the light fixture was “dirt-filled fresh water” or the damage to the ceiling panels was salt deposits.

Similar to the GRD's claim that the light fixtures were not full of urine and fecal matter but only "dirt-filled fresh water," even if we agree that the ceiling panel damage is salt deposits from the fresh water, this is an extremely important issue for the GRD to address. If the fresh water provided to the BPC contains this concentration of salt, the cadets are being exposed daily to a potentially hazardous situation.

Whether the damage to the ceiling panels was caused by urine or fresh water salt deposits, GRD needs to realize that the plumbing system is not only tremendously flawed, but the cadets may be living in a hazardous condition.



Site Photo 100. Urine stain on second floor ceiling



Site Photo 101. Urine stain on second floor ceiling (photo referred to in GRD comments)



Site Photo 102. Enlarged view of Site Photo 101

## **Appendix A. Scope and Methodology**

---

We performed this project assessment from August through December 2006 in accordance with the Quality Standards for Inspections issued by the President's Council on Integrity and Efficiency. The assessment team included a professional engineer/inspector and two auditors/inspectors.

In performing this Project Assessment we:

- Reviewed contract documentation to include the following: Contract, Contract Modifications, Task Order 06, Task Order 06 Modifications, Task Order 29, Task Order 29 Modifications, Contract documentation, and scope of work;
- Reviewed the design package (drawings and specifications), Quality Control plan, Contractor's Quality Control reports, U.S. Army Corps of Engineers Quality Assurance reports, Construction Progress photos, Punch Lists, and Turnover Letters;
- Interviewed the U.S. Army Corps of Engineers Gulf Region Central Resident Engineer, U.S. Army Corps of Engineers Gulf Region Division personnel, and the Multinational Security Transition Command J-7 (Engineering Directorate) staff; and
- Conducted an on-site assessment and documented results at the Baghdad Police College Construction and Renovation Project in Baghdad, Iraq.

## Appendix B. Contract, Task Orders, and Modifications

---

The Baghdad Police College<sup>9</sup> (BPC) project was completed under Contract W914NS-04-D-0009, dated 26 March 2004, as a cost plus award fee for the base period. The contract was between the Coalition Provisional Authority and Parsons Delaware, Inc., Pasadena, California (Parsons). Contract W914NS-04-D-0009 minimum, including option periods, is \$500,000 and the maximum total of all orders under the contract is \$900,000,000.

There were 19 modifications to the initial contract:

- Modification # P00001, issued 6 April 2004, transferred contracting officer authority.
- Modification # P00002, issued 3 August 2004, included the language for processing invoices.
- Modification # P00003, issued 13 August 2004, corrected the modification number on the last modification issued, dated 3 August 2004, from P00001 to P00002.
- Modification # P00004, issued 18 October 2004, transferred administrative responsibility for task orders issued for this contract to the U.S. Army Corps of Engineers (USACE) Gulf Region Division (GRD). The contracting officer reserves the right to modify this delegation for specific TOs.
- Modification # P00005, issued 20 October 2004, incorporated the attached letter of instruction regarding procedures for hostage reporting into the contract.
- Modification # P00006, issued 8 November 2004, incorporated the revised Award Fee Plan and to adjust the Award Fee Period. The initial award fee period was extended to 26 December 2004. Beginning 26 March 2005, the six month award fee periods would resume.
- Modification # P00007, issued 3 December 2004, incorporated the Subcontracts (FAR 52.244-2), Competition in Subcontracting (FAR 52.244-5), and Inspection of Services – Cost Reimbursement (FAR 52.246-5) clauses into the contract. In addition, the warranty language in the TO issued under the contract is restricted to commercial warranties provided by the original equipment manufacturer. As a result of this modification, there is neither an increase nor a decrease in the total amount of this contract.
- Modification # P00008 was not located in the contract file and the following offices (Project and Contracting Office (PCO), the USACE Area Engineer (AE), Resident Engineer (RE), Quality Assurance Representative (QAR), and Parsons Task Manager) were contacted regarding Modification #P00008, but were unable to locate the modification. Modification P00015 stated that Modifications P00003, P00005, P00007, and P00008 do not exist.
- Modification # P00009, issued 4 August 2005, incorporated Defense Federal Acquisition Regulation Supplemental 245.505-14 Contract Clause Defense Federal

---

<sup>9</sup> The Baghdad Police College is also referred to in various documents related to it as the Baghdad Police Academy, Baghdad Public Safety Training Academy, and Baghdad Police Training Academy. For consistency within this report, unless used in a verbatim quotation, we refer to it as the Baghdad Police College.

Acquisition Regulation Supplemental 252-245.7001 Reports of Government Property in the contract.

- Modification # P00010, issued 8 August 2005, transferred administrative responsibility for the TOs issued for this contract to the USACE GRD district offices directly. The Memorandum of Understanding is effective 21 July 2005.
- Modification # P00011, issued 25 August 2005, further amended the Award Fee Plan of the base contract. The changes are made unilaterally and are effective for the award fee period(s) starting after 26 September 2005.
- Modification # P00012, issued 26 October 2005, included the following sentence to the Statement of Work (SOW) 00020 2.6: “Contractor may obtain fuel from Government sources, when available, in support of this contract.”
- Modification # P00013, issued 29 October 2005, rescinded Modification P00012, effective date 6 October 2005. There is no change to Modification P00012, effective date 26 October 2005.
- Modification # P00014, issued 27 November 2005, is to change the word “fifth” in Section 00020 SOW, Paragraph 2.3.5 to “twentieth”.
- Modification # P00015, issued 27 December 2005, changed modification P00001 to read P00002, effective date as 3 August 2004. Modification P00001 had an effective date of 6 April 2004. Modification P00015 stated that Modifications P00003, P00005, P00007, and P00008 do not exist.
- Modification # P00016, issued 28 December 2005, incorporated the requirements for subcontract and capacity development reporting into the Subcontracting Excellence Program Database in accordance with the Subcontracting Excellence Program Database Standard Operating Procedure PR-127 previously furnished.
- Modification # P00017, issued 12 January 2006, included a warranties section for the contract. Except as described above, all terms and conditions remain unchanged and in full force and effect.
- Modification # P00018, issued 5 February 2006, is the transfer GP#743906-1120 (2000 liter fuel tank) from contract number W914NS-04-D-0009 (Parsons Security & Justice) to contract number W914NS-D-0006 (Parsons BHE). All other terms and conditions remain unchanged.
- Modification # P00019, issued 8 February 2006, is to exercise the option for the period of 26 March 2006 through 25 March 2007 in accordance with the option to extend the term of the contract. All other terms and conditions remain unchanged.

There were two TOs associated with work at the Baghdad Police College – TO 0006 and TO 0029.

TO 0006, dated 8 May 2004, was not to exceed \$28,203,841. This TO stated that the Public Safety Training Academy will be constructed in conjunction with the existing National Police Academy and will supplement and expand the training facilities to accommodate training for all departments of the Ministry of Interior.

TO 0006 currently contains 18 modifications.

- Modification 01, dated 1 June 2004, made changes to the work described in the TO. The work is incorporated in the Notice to Proceed (NTP) issued on 8 May 2004.
- Modification 02, dated 11 September 2004, made changes to the work described in the TO, and the work is included in the NTP.

- Modification 03, dated 29 October 2004, increased the amount shown in the Limitation of the Government Liability clause from \$4,230,576 to \$21,152,880.
- Modification 04, dated 7 December 2004, definitized the TO.
- Modification 05, dated 6 February 2005, increased the scope of work and issued a limited NTP. The amount of funds obligated in Modification 04 increased by \$500,000 from \$25,213,936 to \$25,713,936.
- Modification 06, dated 6 March 2005, definitized the additional work, and the estimated completion date for the additional work is 20 April 2005.
- Modification 07 dated 22 May 2005, authorized invoicing for the award fee for the period 26 September 2004 through 26 March 2005 for \$1,160,916. The award fee pool of \$1,499,208 is reduced by \$338,292 for an unearned fee for this period. The TO is deobligated by \$338,292.
- Modification 08, dated 4 June 2005, fully funded the contract. The additional scope of work increased the student capacity from 4,000 to 10,000. In addition, Parsons will provide an additional 600 meters (m) of 12 foot high reinforced concrete T-wall at a cost of \$225,000.
- Modification 09, dated 14 July 2005, definitized the statement of work revision number 5. Due to the increase in scope, the cost of the TO increased by \$6,048,241. The current TO total is \$37,777,415.
- Modification 10, dated 29 December 2005, authorized the invoice and payment of the award fee for the evaluation period March 2005 through September 2005 in the amount of \$685,882. The TO's total definitized price is decreased by \$768,181, from \$37,777,415 to \$37,009,234.
- Modification 11, dated 4 April 2006, partially terminated contract W914NS-04-D-0009, TO 0006 for the convenience of the government, which was effective immediately by terminating the central laundry facility and the physical training field.
- Modification 12, dated 10 May 2006, increased the estimated cost due to cost overruns outlined in Parsons' overrun funding proposal dated 27 February 2006. The estimated cost of the TO is increased by \$5,850,000, from \$33,182,587 to \$39,032,587. The estimated total cost of the TO, including includes all fees, is \$42,859,234.
- Modification 13, dated 17 May 2006, added the following tasks: provide and install an in-line booster pump on the water supply line into the water storage tank; supply 170m of 25mm electrical cable to connect lift stations to temporary power; and supply 10 dump trucks, which shall include operators and fuel, 10 cubic yard capacity for three days. The estimated cost of the TO increased by a NTE amount of \$50,000, from \$39,032,587 to \$39,082,587. The estimated total cost of the TO, including all fees, is \$42,859,234.
- Modification 14, dated 17 May 2006, partially terminated the facilities/tasks on contract W914NS-04-D-0009, TO 0006, BPC. Modification 14 provides a list of items where termination is effective immediately. The remaining contracted work will continue until 31 May 2006.
- Modification 15, dated 18 May 2006, administratively corrected prior modification errors. Modification 13, block 14, should state that the estimated total price of the TO, including all fees, is \$42,909,234.



- Modification 16, dated 25 May 2006, partially terminates contract W914NS-04-D-0009, TO 0006.
- Modification 17, dated 31 May 2006, notified the contractor that the termination was effective immediately upon receipt of the notice. The contractor was to provide a de-scope proposal for this item by 11 June 2006.
- Modification 18, which at the time of this report had not yet been issued. According to GRD representatives, this modification is to identify the amount of the awards fee pool, which is approximately \$1.7 million.

TO 0029, dated 13 June 2004, was not to exceed \$30,000,000. This TO required all labor, materials, and services necessary to perform the work of constructing new buildings and/or renovating, improving, expanding existing buildings to supplement the Baghdad Public Safety Training Academy.

TO 0029 currently consists of eight modifications.

- Modification 01, dated 16 September 2004, changed the pay office to Baghdad, Iraq.
- Modification 02, dated 29 October 2004, increased the amount in the Limitation of Government Liability clause from \$4,500,000 to \$22,500,880.
- Modification 03, dated 7 December 2004, definitized and fully funded the TO.
- Modification 04, dated 28 February 2005, determined the award fee. The contractor was awarded and allowed to invoice for an award fee in the amount of \$1,328,992. The award fee in the amount of \$234,528 is deobligated. The TO amount is decreased from \$29,968,684 to \$29,734,156.
- Modification 05, dated 2 January 2006, deobligated \$389,247 from the potential award fee pool. The remaining award fee pool is reduced by \$781,760 from \$1,563,520 to \$781,760. The contractor is authorized to invoice for \$392,513 for the award fee that covered the evaluation period 26 March 2005 through 25 September 2005. Therefore, the total definitized price for this TO is decreased by \$389,247 from \$29,734,156 to \$29,344,909.
- Modification 06, dated 4 March 2006, partially terminated TO 0029 by terminating the communication building and the new fitness center. Parsons shall provide a settlement proposal, which shall include incurred costs plus the cost to complete, no later than 3 April 2006.
- Modification 07, dated 17 May 2006, partially terminated TO 0029 by immediately stopping work on the renovation and restoration of the existing police athletic club; refurbishment of the storage closet under the bleacher; construction of the new driving course; and the renovation of the gymnasium with the basketball court.
- Modification 08, dated 31 May 2006, terminated the contract W914NS-04-D-0009 effective immediately upon receipt of the notice. A de-scoped proposal should be provided by 11 June 2006. All work shall stop at the BPC, except to continue work to complete the guard towers until 7 June 2006.

## Appendix C. De-Scoped Task Order Items

Task Order	Modification Number	Modification Date	De-scoped Work	Percentage Complete	Original Estimated Cost of Item (See Note 3)	Amount Paid (See Note 3)
6	11	4 May 2006	De-scope Laundry Facility	50.9		
6	11	4 May 2006	De-scope PT Field	22		
6	13	17 May 2006	Additional work on pumps & trucks	100		
6	14	17 May 2006	Terminate indoor dining facility	77.8		
6	14	17 May 2006	Terminate extra work on AO & AN	0.0		
6	14	17 May 2006	Terminate structural repairs	0.0		
6	14	17 May 2006	Terminate construct new parking lot	Included under TO 6, Mod 16, "Terminate Paving"		
6	14	17 May 2006	Terminate install water heaters for buildings	0.0		
6	14	17 May 2006	Terminate water & sewer in building A & BA	0.0		
6	14	17 May 2006	Terminate interior building rewiring	0.0		
6	14	17 May 2006	Terminate refurbish gate	0.0		
6	14	17 May 2006	Terminate connect to power grid	0.0		
6	14	17 May 2006	Terminate moisture protection	0.0		
6	14	17 May 2006	Terminate doors & windows	0.0		
6	14	17 May 2006	Terminate fire protection	0.0		
6	16	25 May 2006	Terminate paving	34.0 See Note 1		
6	17	31 May 2006	Terminate remaining work except for electrical SOW	See Note 2		
29	6	4 March 2006	Terminate communication building	37.7		
29	6	4 March 2006	Terminate Athletic complex	7.9		
29	7	17 May 2006	Terminate gymnasium renovation	54.0		
29	7	17 May 2006	Terminate driving course	0.0		
29	7	17 May 2006	Terminate bleachers	0.0		

			storage area			
29	7	17 May 2006	Terminate fitness club	43.0		
29	8	31 May 2006	Terminate remaining work except for guard towers	See Note 2		

Notes<sup>10</sup>:

1. "Terminate Paving" under Task Order 6, Modification 16 includes the construction of the new parking lot (de-scoped), pave site wide parking & road, and construct side wide minor path ways.
2. Prior to the direction to stop work for Task Orders 06 and 29, several earlier modifications were issued which de-scoped a significant portion of the work from both Task Orders. Task Order 06, Modification 17 directed the contractor to stop all work at the BPC with the exception of commissioning, testing and completing the electrical distribution. Task Order 29, Modification 8 directed the contractor to stop all work at the BPC with the exception of completing the guard towers.
3. Amounts for the last two columns (Original Estimated Cost of Item and Amount Paid) are not readily available for each separate de-scoped work item as these amounts are tracked in aggregate for several structures and/or systems.

---

<sup>10</sup> The Gulf Region Division, in its comments to the draft report, requested the inclusion of the Notes section to clarify the responses in the table. We included the Gulf Region Division's Notes verbatim.

## Appendix D. Work Completed

---

### Cadet Barracks

TO 29 required the construction of multi-story dormitories/barracks to house up to 2,800 cadets. Based upon our site visit, we determined the eight cadet barracks were three-story buildings (ground floor plus two additional floors - see Site Photo 103 for an example of the exterior of one complete barracks building). A similar building design was used to house the most number of cadets economically by providing modern services. The ground floor consisted of four large, multi-occupancy bedrooms with bunk beds to maximize the occupancy, two administrative offices, a separate male and female toilet room with showers, and a large common area. The first and second floors consisted of 14 bedrooms of similar size and configuration to maximize occupancy and a communal bathroom facility with toilets, urinals, sinks, and showers. The ground floor common area was to be wired for TV and internet service and be used for relaxation and studying. At the time of the initial site visit, the completed barracks were being used by cadets.



**Site Photo 103. View of exterior of cadets' building**

In a previous inspection report, we identified significant plumbing issues within the cadet and instructors' buildings<sup>11</sup>. The suspended ceilings of the cadet barracks buildings were removed to show us water damage. We identified segregation, honeycombing, and voids in the structural concrete members as well as exposed reinforcement bars (Site Photos 104-108).

---

<sup>11</sup> For the entire report, see SIGIR report, "Quick Reaction Report on the Baghdad Police College, Baghdad, Iraq," 27 September 2006.



**Site Photo 104. Cadet barracks concrete work**

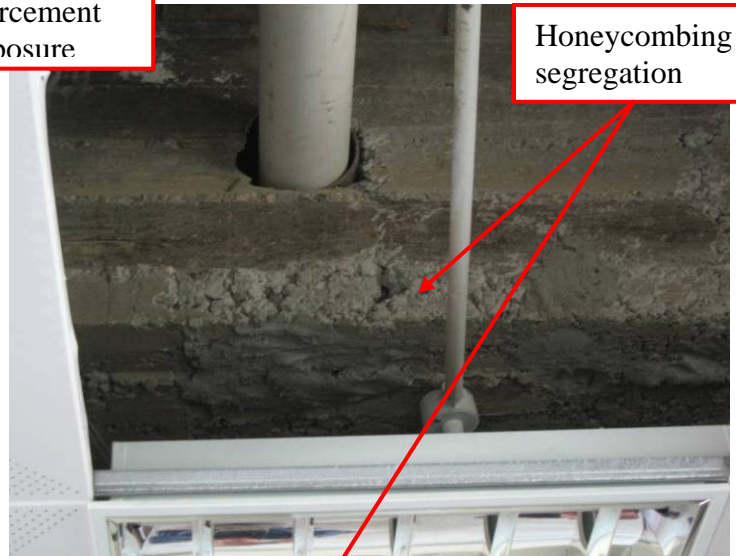


**Site Photo 105. Cadet barracks concrete**



Reinforcement bar exposure

**Site Photo 106. Cadet barracks concrete work**



Honeycombing and segregation

**Site Photo 107. Cadet barracks concrete work**



**Site Photo 108. Cadet barracks concrete work**

In the ground floor common area, we witnessed the effects of leaking water from the top two floors (Site Photo 109). The water damage to the walls was so extensive that the plaster had to be removed. When the plaster was removed, we identified evidence of poor quality brick and masonry work of the non-load bearing walls, such as broken pieces of brick and spaces between the bricks filled with small chips of material (Site Photo 110).



**Site Photo 109. Water damage to cadet barracks ground floor common area**



**Site Photo 110. Close-up view of brickwork from Site Photo 109**

Each multiple occupancy cadet bedroom was approximately 5.5 meters (m) wide by 6.5m long and consisted of six bunk beds housing 12 cadets (Site Photo 111). Inside each room were a ceiling fan, two windows, two ceiling lights, and a split air conditioning unit. We identified poor construction techniques employed for the door frames (Site Photo 112). The first and second floor communal bathrooms consisted of 11 urinals (Site Photo 113), one dressing/changing room, two western and eight eastern-style toilets (Site Photo 114), 10 showers, and nine sinks (Site Photo 115). During our site visit, we noticed problems with the bathroom fixtures, such as low quality sinks and sink fixtures, shower fixtures and assemblies, and hoses (Site Photo 116), which resulted in broken fixtures and leaks (Site Photos 117 and 118).

The original intent of the ground floor common room was for relaxation and studying and was wired for TV and internet connectivity. However, due to the water leaking into the room from the bathrooms upstairs, the room was not used for its intended purpose; rather it was used for the storage of miscellaneous items (Site Photo 119). In addition, BPC representatives stated that TV and internet connectivity was never completed.

Finally, we identified structural deficiencies with the staircase; specifically the de-lamination of one step (Site Photo 120) and a large crack of another staircase (Site Photo 121). Underneath the staircase, we identified what appear to be stress cracks (Site Photos 122 and 123).



**Site Photo 111. Interior of cadet barracks bedroom**



**Site Photo 112. Poor door frame installation**



**Site Photo 113. Urinals in cadet barracks**



2 western and 3 eastern toilets

5 eastern toilets

**Site Photo 114. Eastern and western toilets**



**Site Photo 115. Sinks in cadet barracks bathroom**



Faucet not securely attached and moved by hand

**Site Photo 116. Example of low quality sink fixtures**



**Site Photo 117. Broken sink fixture**



**Site Photo 118. Leaking water**





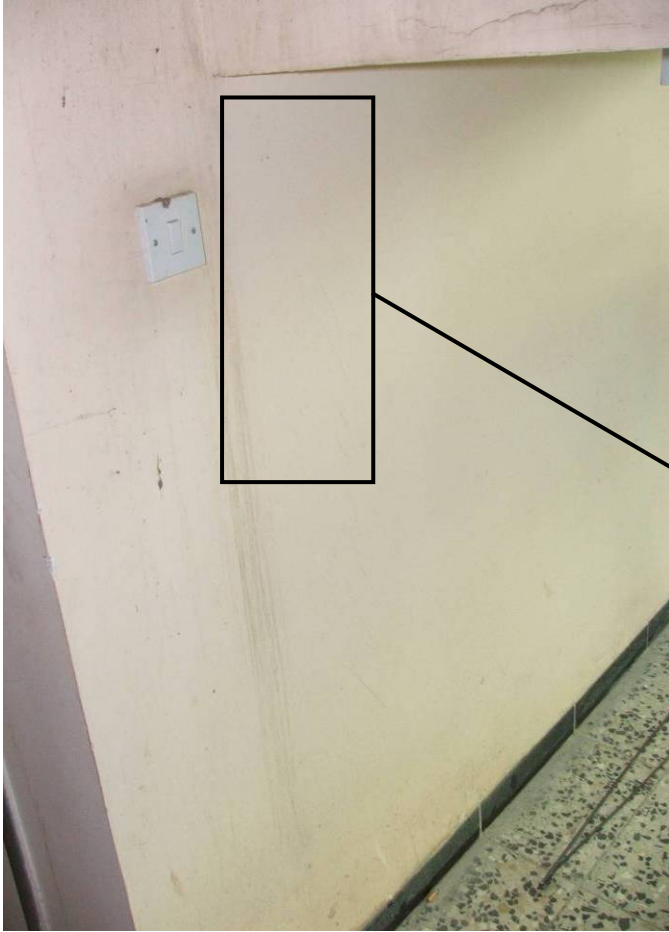
**Site Photo 119. Cadet barracks common area used for storage of miscellaneous items due to continuous water leakage**



**Site Photo 120. De-lamination of staircase step**



**Site Photo 121. Staircase crack**



**Site Photo 122. Stress cracks underneath staircase**



**Site Photo 123. Enlarged view of Site Photo 122**

### Instructors' Barracks

TO 29 required the construction of new billeting to accommodate 150 instructors. Based upon our site visit, we determined that the two instructor barracks were three-story concrete buildings (Site Photo 124) with 20 single occupancy bedrooms (with private bathrooms) and a communal area on the ground floor; and 26 single occupancy bedrooms (with private bathrooms) on the first and second floors. According to the design drawings, each bedroom is 4.2 meters (m) x 4.25m, and each bathroom is 1.8m x 2.5m.



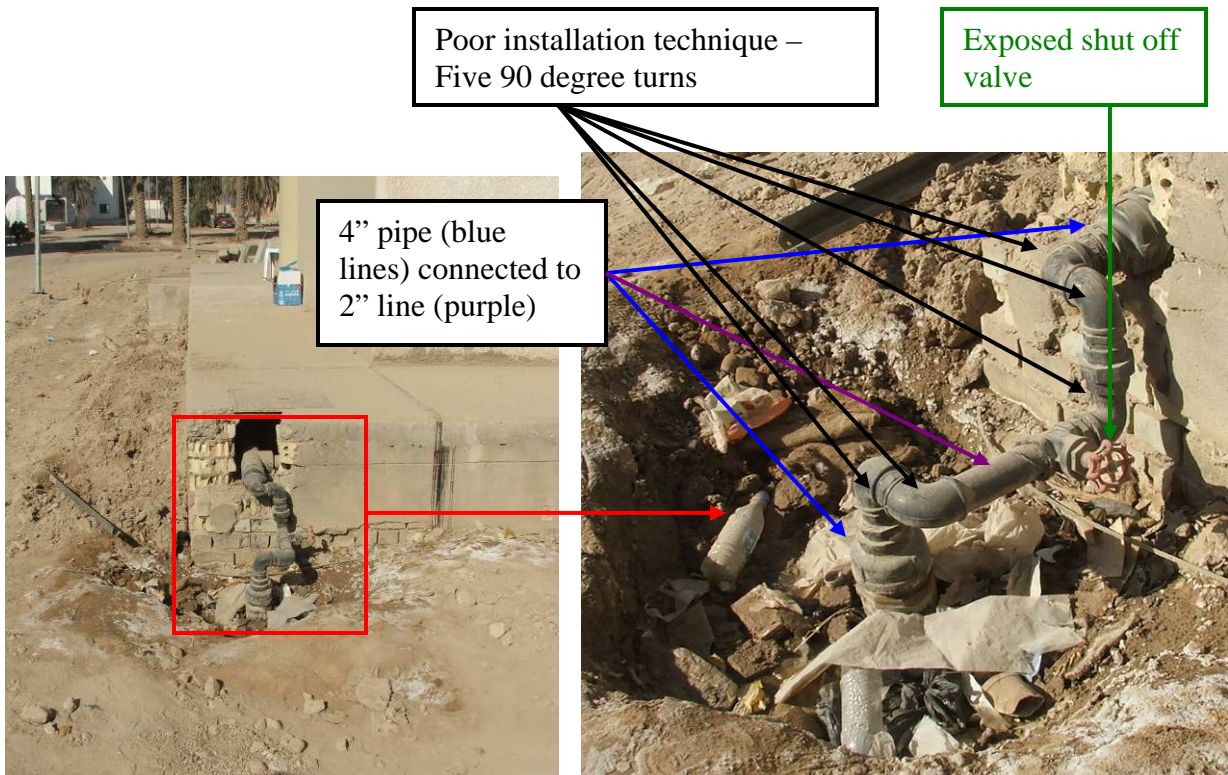
**Site Photo 124. Exterior view of the instructors' barracks**

We inspected the instructors' barracks on 1 December 2006, at which time BPC representatives stated that none of the instructors' barracks had been occupied or put under a full electrical or water/sewer<sup>12</sup> load because the buildings were neither connected to generators nor to the sewer network. BPC representatives stated the buildings are locked and only the subcontractor and BPC had access to the buildings.

Prior to entering the building, we identified the main water line connection (Site Photo 125). This water line connection is poorly installed. It has five separate 90 degree turns from the pipe exiting the ground to the line in the foundation (Site Photo 126); the pipes and shutoff valve are exposed to the elements (i.e., water and sun, which will ultimately lead to rust), and the pipes are not covered to reduce the chance of damage from vehicle traffic (since the pipe line is close to the street). According to GRD's independent assessment, the "...standard method of construction is to secure the shut off valve inside a cast iron box with cast iron cover." Finally, the main water line connection is peculiar since multiple sized pipes are utilized. Specifically, there is a reduction from the 4" main pipe to a 2" pipe and then expanding to a 4" pipe (Site Photo 126).

---

<sup>12</sup> The term soil pipe, waste water pipe, sewer pipe, and drainage pipe are interchangeably used throughout the report for waste water disposal system.



**Site Photo 125. Main water line connection for instructors' barracks**

**Site Photo 126. Close-up view of main water line**

The ground floor consisted of single bedrooms with private bathrooms. We identified tar damage in the bathrooms, which leaked from the roof down to the ground floor (Site Photos 127-130). We also identified poor quality construction of an electrical outlet (Site Photo 131). This electrical outlet was not only painted over, it was plastered over with mortar as well. As a result, this electrical outlet will never be operational. Because neither building has generator power or water and sewer connections, we were unable to determine if the electrical fixtures or the plumbing systems worked correctly.



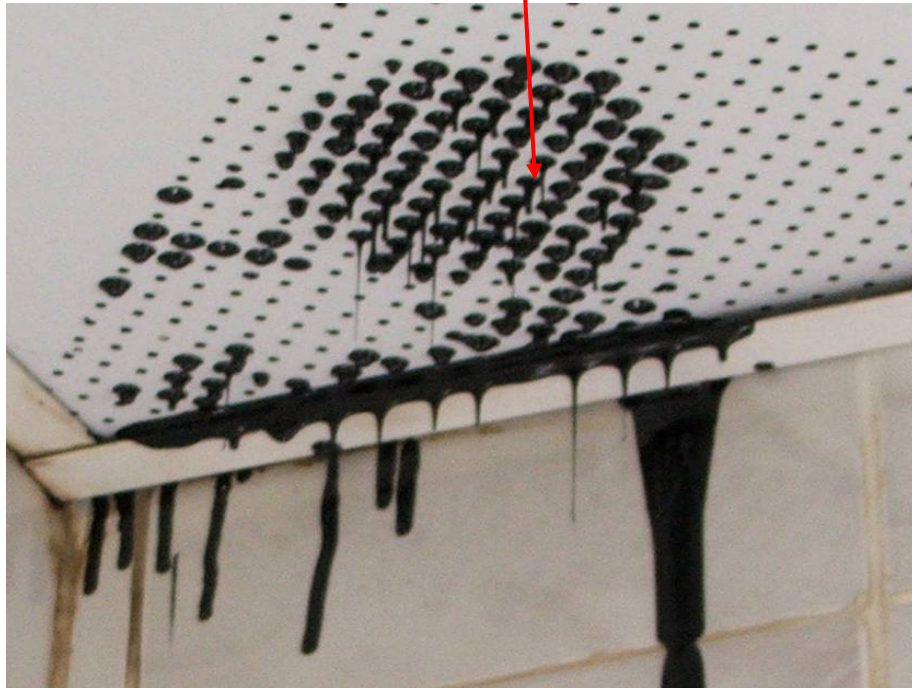
**Site Photo 127. Tar damage on wall and floor of an instructors' barracks bathroom**



**Site Photo 128. Close-up view of tar damage from Site Photo 127**



**Site Photo 129. Ceiling and wall damage in bathroom**



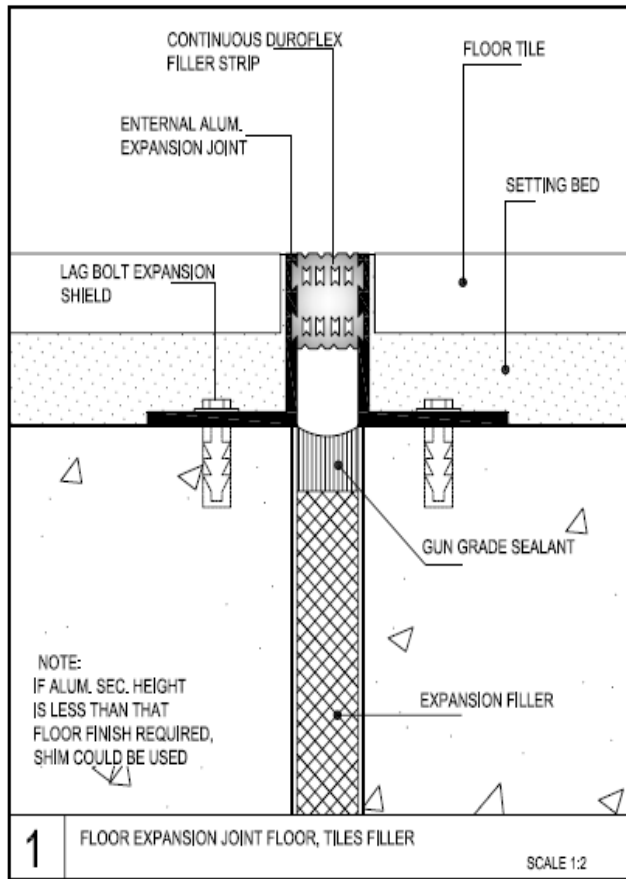
**Site Photo 130. Enlarged view of ceiling damage seen in Site Photo 129**



**Site Photo 131. Electrical outlet covered with mortar and paint**

More importantly, we discovered significant expansion cracks on the interior and exterior of the buildings. The contractor submitted as-built drawings claiming to have installed a specific type of expansion joint system for the floor, interior wall, ceiling, exterior wall, and roof. The as-built drawings submitted show a very specific prefabricated joint system. The materials and methods to install each type of joint require a high level of skill, experience, and understanding; however, from the expansion cracks we verified, it appears the contractor did not have the skill level, experience, and understanding to adequately install the expansion joints.

We found little or no evidence of designed joints in place to protect the building from vertical and horizontal movement. Properly designed and correctly installed joint systems are capable of protecting buildings and structures from damage caused by thermal expansion and contraction as well as anticipated foundation movements. The damage we identified is a direct result of not properly installing the expansion joints according to the as-built drawings (Figures 11 and 12 and Site Photos 132-135). The absence of properly installed expansion joints could potentially result in further damage to the buildings' interior and exterior, as well as, significantly reduce the buildings' life expectancy.



**Figure 11. As-built drawing for expansion joint**

Expansion joint not installed as claimed in as-built drawings

Expansion crack caused by not installing expansion joint correctly



**Site Photo 132. Interior expansion crack**



Expansion crack from not using the correct material

**Site Photo 133. Interior expansion crack in the instructors' barracks**



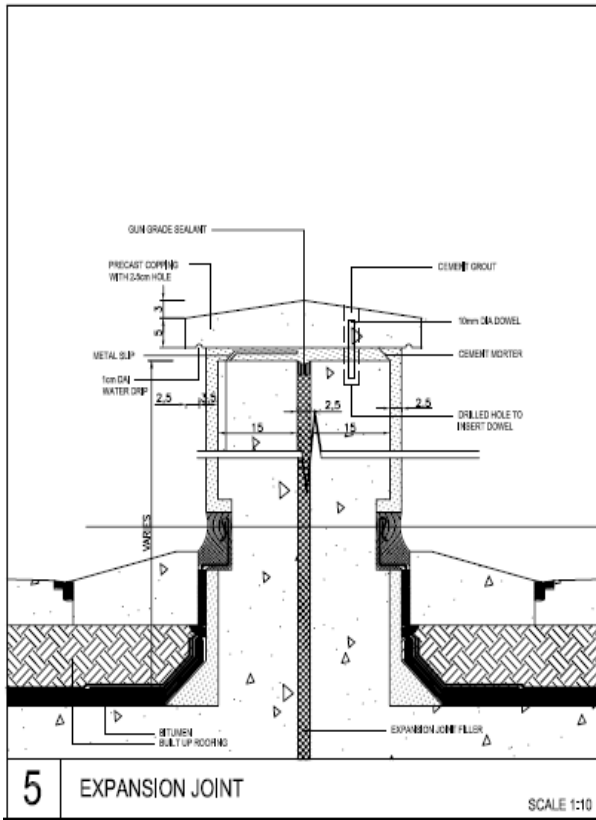


Figure 12. As-built drawing for expansion joint



Site Photo 134. Expansion crack on roof



Site Photo 135. Enlarged view of expansion crack from Site Photo 103

### Language Instructors' Barracks

TO 29 required the construction of new billeting to accommodate 150 language instructors. Based upon our site visit, we determined that the two instructor barracks were three-story concrete buildings (Site Photo 136) with 10 single occupancy bedrooms (with private bathrooms) and a communal area on the ground floor; and 18 single occupancy bedrooms (with private bathrooms) on the first and second floors. According to the design drawings, each bedroom is 4.8m x 4.25m, and each bathroom is 1.52m x 2.3m.

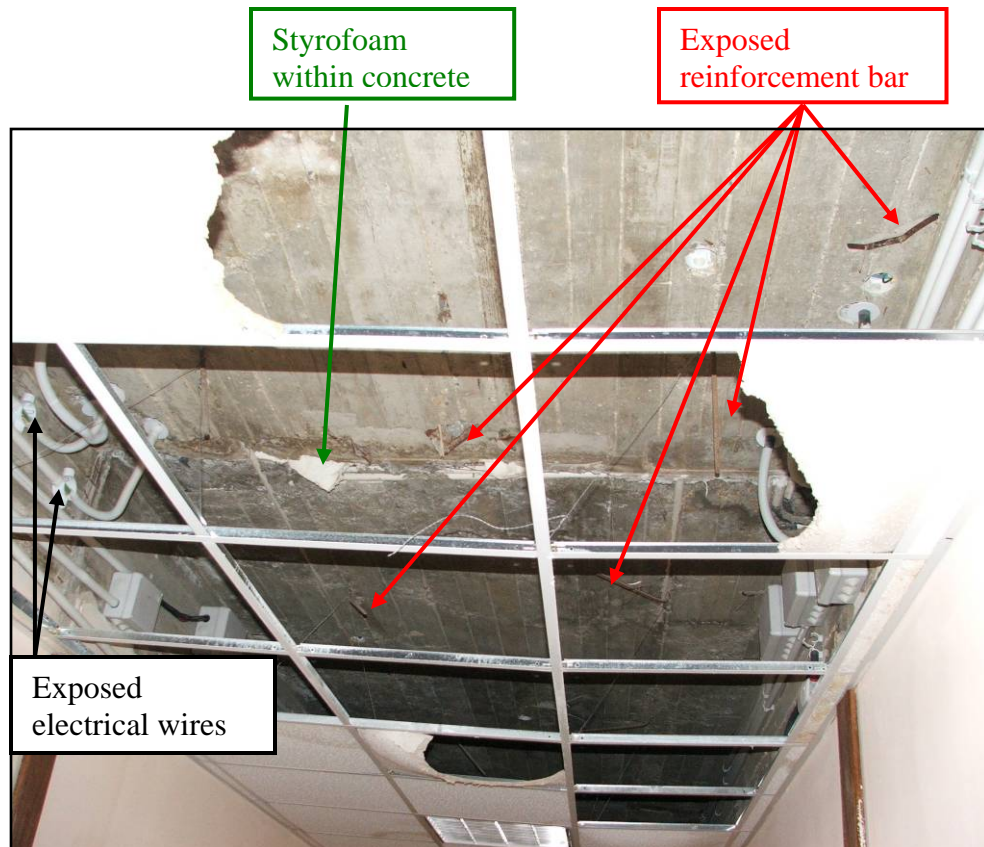


**Site Photo 136. Exterior view of the language instructors' barracks**

We inspected the language instructors' barracks on 1 December 2006, at which time BPC representatives stated none of the language instructors' barracks had been occupied or put under a full electrical or water/sewer load because the buildings were neither connected to generators or to the sewer network. BPC representatives stated the buildings are locked and no one other than the subcontractor and BPC had access to the buildings.

BPC representatives stated that one language instructors' barracks had sustained water damage resulting from a water faucet left on for an extended period of time.

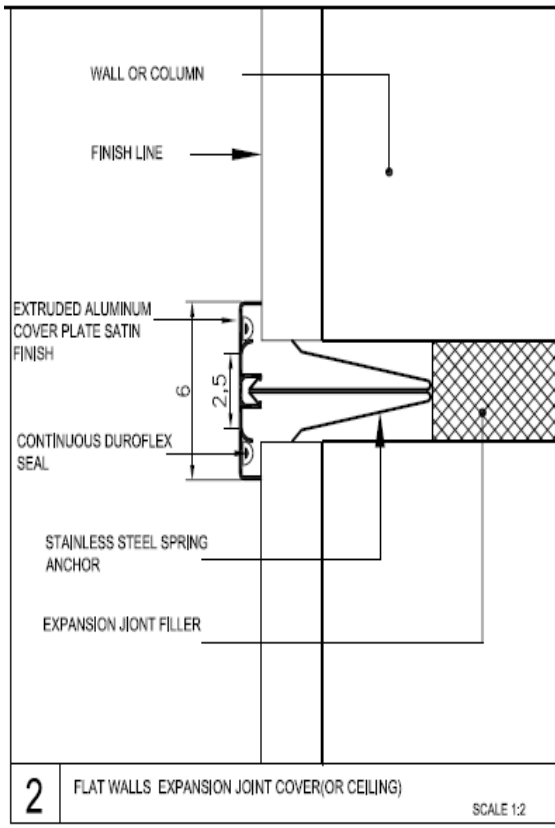
The ground floor consisted of single occupancy bedrooms with private bathrooms. We identified tar damage in the bathrooms from tar leaking from the roof down to the ground floor. In addition, we identified exposed reinforcement bar, Styrofoam within the concrete formwork, and exposed electrical wires (Site Photo 137). Since neither building has generator power or water and sewer connections, we were unable to determine if the electrical fixtures or the plumbing systems worked correctly.



**Site Photo 137. Poor quality construction work in the language instructors' barracks**

Similar to the instructors' buildings, we discovered significant expansion cracks on the interior and exterior of the buildings. The contractor's as-built drawings required a specific type of expansion joint system for the floor, interior wall, ceiling, exterior wall, and roof. The as-built drawings submitted show a very specific prefabricated joint system. The materials and methods to install each type of joint require a high level of skill, experience, and understanding; from the expansion cracks we verified, it appears the contractor did not have the skill level, experience, and understanding to adequately install the expansion joints.

We found little or no evidence of designed joints in place to protect the building from vertical and horizontal movement. Properly designed and correctly installed joint systems are capable of protecting buildings and structures from damage caused by thermal expansion and contraction as well as anticipated foundation movements. The damage we identified is a direct result of not installing the expansion joints according to the design drawings (Figure 13 and Site Photos 138 and 139). The lack of properly installed expansion joints could potentially result in further damage to the buildings' interior and exterior, as well as, significantly reduce the buildings' life expectancy.



**Figure 13. As-built drawing for expansion joint**



Major expansion crack on front of building (absence of engineered joint)

**Site Photo 138. Exterior expansion crack**



Major expansion crack located on rear side of building. View is looking from the roof toward the ground. Absence of engineered joint.

**Site Photo 139. Significant exterior crack in the language instructors' barracks**

## Classrooms

TO 06 required the construction of new teaching facilities for a minimum of 3,300 students. Based upon our site visit, we determined the eight classroom buildings were two-stories with seven classrooms, additional rooms for offices and stores, one set of male and female bathrooms, one private officer's bathroom, kitchenette, and a janitor's room per floor (Site Photo 140). At the time of the initial site visit, the completed classrooms were being used by cadets.

In the ground floor male bathroom area, we witnessed the effects of leaking water from the top floor (Site Photo 141). The classroom plumbing issues apparently were similar to the problems experienced in the cadet and instructors' barracks – poor installation practices coupled with defective pipes and fittings.

In addition, we identified evidence of poor and/or improper installation of door frames and ceramic tiles, specifically in the bathroom areas (Site Photo 142).

Further, the ground floor of Classroom E was not flat (Site Photo 143). The floor sloped downward to the right when approaching the female bathroom.



**Site Photo 140. Exterior view of Classroom E**



**Site Photo 141. Example of water damage**



**Site Photo 142. Example of poor installation**



**Site Photo 143. Poor construction of the first floor in Classroom E**

## Ablution Unit

TO 29 required the construction of an ablution unit near the mosque. The ablution unit was needed to allow the Muslim cadets and instructors to follow the tradition of washing their feet prior to entering a mosque. According to the design drawings, the ablution unit is a single-story building (Site Photo 144) consisting of two eastern toilets, two sinks, a hot water heater, and an area to wash feet with eight individual sinks. At the time of our initial site visit, BPC representatives advised us that the ablution unit was completed; however, we determined that it had not been hooked up to the water and sewer systems. Once the contractor indicated that it completed the building, the door was locked and no one entered the facility.

On a subsequent site visit on 1 December 2006, we visited the ablution unit, which had recently been connected to the water and sewer systems (Site Photos 145 and 146). According to GRD representatives, a new contract had to be awarded to another contractor to connect the ablution unit to the main water and sewage networks. There were eight individual sinks and seats (Site Photos 147 and 148) along with two toilet rooms. The design drawing required a hot water heater to warm the water during the winter months, which we verified was present in the facility. The ablution unit appeared to meet the requirements of the TO.

We mentioned earlier in the report that a Beneficial Occupancy form was signed for the ablution unit in May 2006 even though it was not connected to the main water and sewage networks. Since the ablution unit was only connected to the main water and sewage networks in late November 2006, the BPC cadets and instructors, for approximately 7 months, did not have a facility to wash their feet prior to entering the BPC mosque.



**Site Photo 144. Exterior view of the ablution unit**



**Site Photo 145. Connection to water network**



**Site Photo 146. Connection to main sewer network**



**Site Photo 147. Interior of ablution unit**



**Site Photo 148. Sinks for feet washing**

### Forensic Laboratory

The forensic laboratory is a single-story concrete structure (Site Photo 149), which is currently being occupied by the British forensic team. The building consists of four laboratory rooms, two offices, two sets of male and female water closets, a kitchen, a classroom, and miscellaneous rooms used for evidence storage, polygraphs, chemical examination, and ballistics. During the site visit, we identified a water leak from the equipment installed above the suspended the ceiling (Site Photos 150 and 151). We were told the damage was caused by poor installation of the existing water heater above the ceiling. We toured the rooms within the building, which are complete and appeared to be consistent with the design drawings. At the time of our site visit, British Forces were occupying the building; however, little equipment was present inside.





**Site Photo 149. Exterior view of forensic laboratory**



**Site Photo 150. Water damage on ceiling panel**



**Site Photo 151. Close-up view of water damage**

### Library and Archive Building

The library and archive building is a single-story concrete structure (Site Photo 152), which is currently being used as a badge office. The design drawings called for and the contractor provided a handicapped ramp in the front of the building (Site Photo 153). The interior of the building consisted of several small rooms and one male and female water closet. We did not observe any problems or defects in any of the building's interior; however, we did observe some concrete defects near the handicapped ramp (Site Photo 154).



**Site Photo 152. Exterior view of library**



**Site Photo 153. Defective concrete work**



**Site Photo 154. Close-up view of Site Photo 153**

### Armory

TO 29 required the construction of a new armory building with a magazine area, weapons area, and workshop to accommodate four people. According to BPC personnel, the Ministry of Interior did not want an armory; therefore, it was redesigned and converted into a warehouse. It is a one-story steel structure building with reinforced concrete and a two story section in the middle. At the time of our site visit, BPC representatives stated the building had been turned over to the Iraqis who presently use the armory as a warehouse. The building was locked; however, we did confirm the existence of a single-story structure (Site Photo 155). According to BPC representatives, there have been no construction issues reported about this building.



**Site Photo 155. Exterior view of the armory building**

### Range Administration Building

TO 06 required the construction of a range area administration/training building with 10 range classrooms, five offices, six FATS rooms, storage closets, and restrooms. The range administration building is a single-story facility (Site Photo 156), with several classrooms, offices, and restrooms. In the hallway, we saw evidence of termite damage to the wall (Site Photo 157). The restrooms consisted of urinals, eastern and western style toilets, sinks, and hot water heaters. The classrooms contained split air conditioning units, windows, ceiling and wall lights, and ceiling fans. In one restroom and classroom, light fixtures had either fallen or were separating from the ceiling (Site Photos 158 and 159). We were unable to verify the electrical and water systems because the facility had no generator power nor was it connected to the main water or sewer lines.



**Site Photo 156. Exterior view of range administration building**



**Site Photo 157. Example of termite damage to interior wall**



**Site Photo 158. Poor installation of light fixture**



**Site Photo 159. Poor installation of light fixture**

According to the Beneficial Occupancy form for the range administration building, the "...level of the building sewer system is under the level of the academy sewer system." This required a sewage pump station to pump the waste water into the main sewage line. GRD representatives stated a pump station near the range administration building was part of the new site sewer system; however, since the building's sewer system was built under the level of the academy's overall sewer system, a pump station had to be designed and constructed. We could not determine whether the design or the construction of the range administration building caused the sewer system to be lower than the overall academy sewer system. GRD representatives stated that Parsons built a new pump station but it was never connected to a permanent electrical power source because the requirement to do so was de-scoped. A new contract was awarded to another contractor to connect the existing pump system to electrical power. However, the new contractor determined that the existing system (i.e. pump station built by Parsons) "as installed was of poor quality and unreliable design..." Site Photo 160 is the single pump station installed by Parsons.

The new contractor recommended, and GRD agreed, to upgrade to a dual pump design. On our last visit on 8 December 2006, we verified the installation of a dual pump design. The construction of the pump station was of poor quality. The control panel base was

rudimentary and there was no protection for the control panel from the elements, such as extreme summertime heat, rain, wind, dust, and dirt (Site Photos 161 and 162). In addition, an elevated sewer manhole was created by pouring concrete on a used manhole ring over the existing hole (Site Photo 163). PVC pipe carrying the electrical wires was partially covered with concrete; however, the entire length of the PVC pipe was not covered, which leaves it vulnerable to damage from the elements (Site Photo 164).

Further, the contractor poorly connected the electrical power wires to the pump station. From the power source to the base of the manhole, the electrical power wires were not placed in a conduit nor were the buried wires placed an appropriate depth under ground (Site Photo 165). At the time of the visit, the pump station appeared to be full of test water (Site Photo 166). BPC representatives stated the USACE GRD had informed them that the new pump station was currently ready for use. However, it did not appear to us to be operational. On 19 December 2006, we met with BPC representatives who stated the new pump station did not work because the contractor had not installed the correct type of pump. A pump which grinds the sewer solids had not been installed as necessary in order for the pump station to be operational. Consequently, the range administration building, a \$1.2 million facility, which the USACE GRC stated was ready for occupancy in June 2006, still could not be used.

As a result of poor oversight by the GRC, Parsons either designed or constructed the building's sewer system below the academy's sewer system; and the contractor's new installation of a pump station was of "poor quality and unreliable design." However, the contractor was paid for the design and construction of both the building and the pump station. Further, a continuing lack of oversight by GRD allowed the new contractor to install an incorrect type of pump, which has caused additional delays to the use of the range administration building.



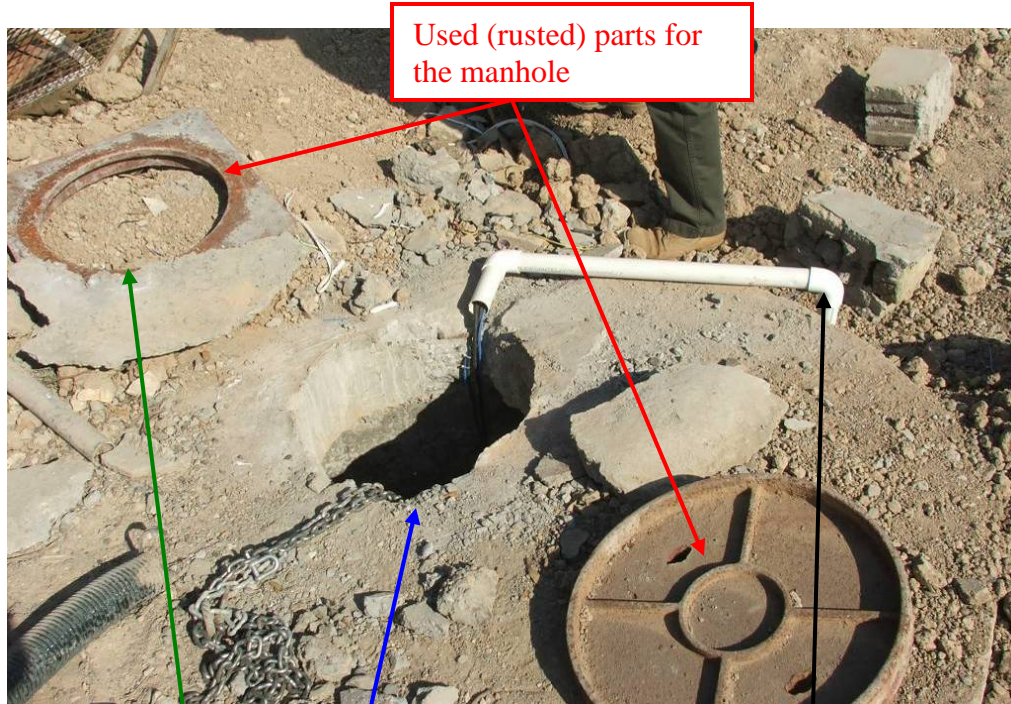
**Site Photo 160. Original single pump station installed by Parsons but never connected to power**



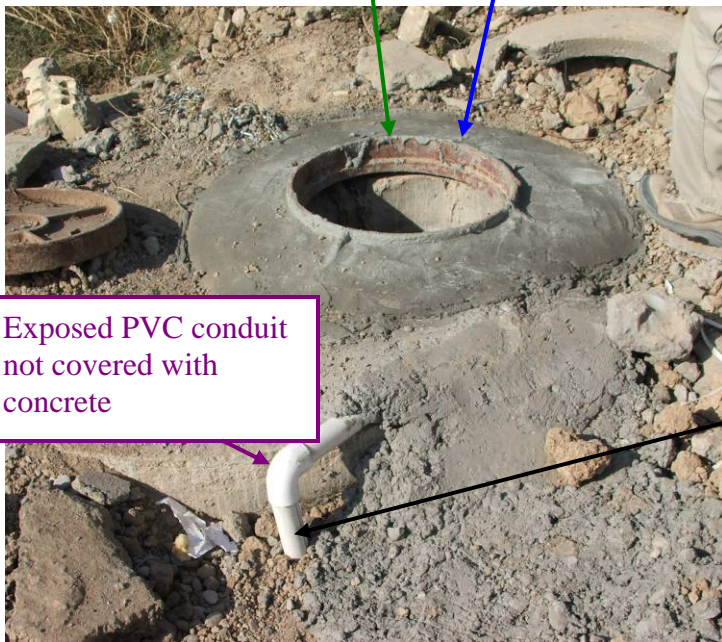
**Site Photo 161. Dual pump station control panel base**



**Site Photo 162. Dual pump station control panel**



Site Photo 163. Sewer manhole as of 1 December 2006



Site Photo 164. New elevated manhole as of 8 December 2006



Site Photo 165. Exposed electrical power lines to pump station



**Site Photo 166. New constructed dual pump station, which is not operational due to the installation of the incorrect type of pump**

### Motor Pool

TO 06 required the demolition of the existing roofed car park and construction of a motor pool with car lifts, a maintenance shop, a controlled access tool room, a billeting facility, and a re-fueling station. According to BPC representatives, the motor pool is currently being used by the BPC maintenance contractor, Saudi Arabian Trading Company (SATCO). The facility was previously looted after being turned over to the BPC. We verified the motor pool is a single-story facility (Site Photo 167) with car lifts (Site Photo 168), maintenance shop, miscellaneous rooms, and re-fueling station (Site Photo 169). We did not observe any problems or defects with the construction of the facility. However, BPC representatives have significant concerns about the two fuel tanks. The fuel tank pumps, one gasoline and one diesel, are in the ground and wired; yet, they were not tested and certified by the contractor for stability, proper electrical work, and grounding for static electrical charge. According to BPC representatives, a Parsons' subcontractor was upset about not being paid and allegedly cross wired the fuel tanks. As a result, because BPC representatives are so concerned the cross wired tanks could potentially lead to a major explosion; therefore, they do not use the fuel tanks. Consequently, in the absence of required tests and certifications for the fuel tanks, BPC representatives do not have access to the fuel tanks.





**Site Photo 167. Exterior view of motor pool facility**



**Site Photo 168. Car lift within the motor pool**



**Site Photo 169. Re-fueling station**

### Water Storage Tank

The water storage tank was constructed on the southwest part of the BPC campus (Site Photo 170). The only drawings available for the water storage tank are the as-built drawing submitted by the contractor. According to the as-built drawings, the overall external dimensions of the tank are 30m x 20m with a depth of 3m, and an overall storage capacity of 1,125,000 liters. There is a pump room that is 7.55m x 5m and is attached to

the tank. The pump room holds four booster pumps (Site Photo 171), valves, power supply, and an electronic control panel (Site Photo 172).



**Site Photo 170. Exterior view of water storage tank and pump room**



**Site Photo 171. Four booster pumps in pump room**

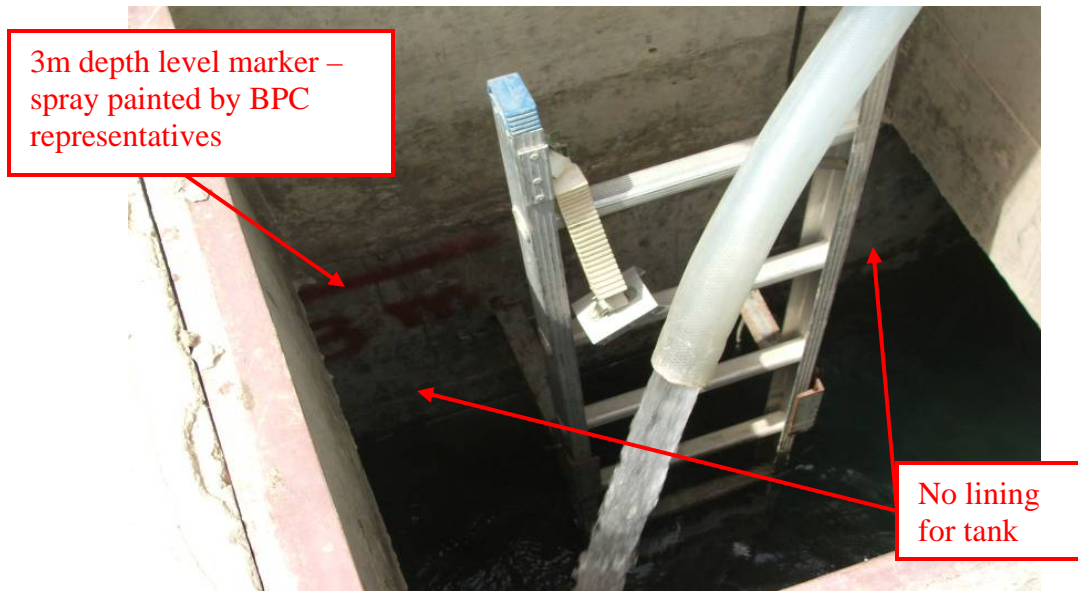


**Site Photo 172. Electronic control panel in pump room**

We reviewed the as-built structural design drawings, which did not include actual soil boring test data. Based upon the stated assumptions on the as-built drawings for soil capacity and design criteria, the structural design appears to be adequate. However, the absence of design calculations, actual soil test data, construction methods, and material test data, we are unable to draw any definitive conclusions. We were also not provided with any photographic documentation to substantiate the application of required standards for material, adequate construction methods and techniques, and use of the required equipment.

The submitted as-built drawings provided no information regarding the interior finishing or lining of the water storage tank. In the absence of such information and water quality data for the city supplied water to this tank, it is not possible to draw any conclusion about the outgoing water usage type. We have not seen any test documents for the structural integrity of this tank at the designed volume, water proofing, plumbing test under sustained design pressure for water mains-pumps-motor, and control panel. However, we did verify that there is no lining for the water storage tank, which was

confirmed by BPC representatives who had to enter the tank to spray paint the depth level of the tank (Site Photo 173). A water storage tank without the appropriate lining is susceptible to the growth of algae and other bacteria, which will pose a potential health hazard to the BPC campus.



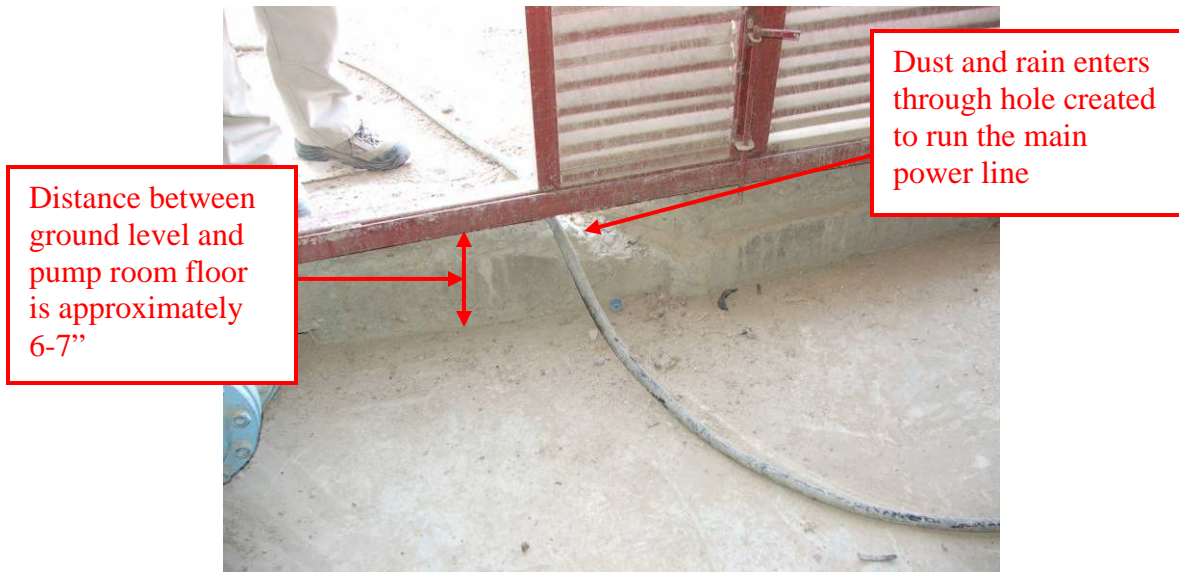
**Site Photo 173. Water trucked into the BPC is being poured into the unlined water storage tank**

We observed limited operation of the water storage tank, which appeared to be functional. However, access to both the control room and to the top of the tank for operational functions is not adequate. The control room supporting the critical operation of this tank is below normal ground level, increasing the potential of heat, dust, and rainwater entering the room (Site Photo 174). During our site visit, we found the pump room to be extremely dusty and dirty; specifically the floor and pumps (Site Photo 175). In addition, we found the electrical wires on the pump room floor (Site Photo 176). During the rainy season, the likelihood of water entering the room through the hole for the power cable and ruining the electrical wires is exponentially increased. We did not observe any floor drains or pumps to remove water from the control room. Finally, with the pump room floor approximately 6-7" below ground level, it will be extremely difficult to keep the room clean.

We were unable to inspect the entire plumbing and electrical systems, but they appeared to be in place. The main power supply cable was brought into this room by punching a hole under the door frame and was left on the floor to energize the pumps, motors, and control panel. We also noticed the cables providing signals to the pumps, motors, and valves from the control panel on the floor. In the event of water entering the pump room, there is the potential for significant damage to the support equipment, high pressure water main, and power generator. This would lead to a cutoff of water to the entire BPC campus for an extended period of time for repairs.

We did not witness the operation of booster pumps, control panel, or the automated valve system. Further, we did not see any spare parts, posted operating instruction, safety notice, safety instructions, operating manuals or training manuals/logs for personnel responsible for the continual safe operation of the water storage tank. During our 4 September 2006 visit, there was a problem with the electrical panel, which resulted in

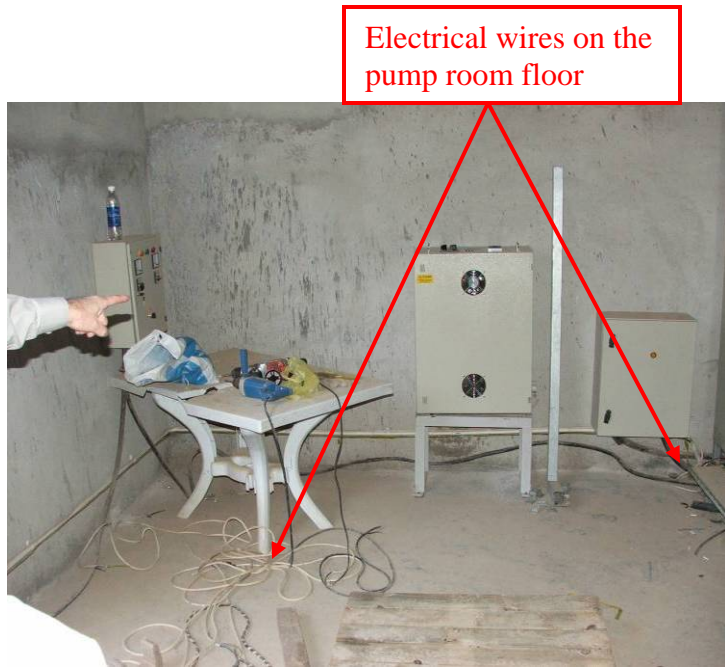
there being no water available for the BPC campus. GRD representatives were present and attempted to reprogram the control panel. However, GRD representatives could not locate the operating manuals and were not successful contacting the subcontractor. Later, GRD representatives stated the BPC did not have the access code to the control panel.



Site Photo 174. Pump room is below the college ground level



Site Photo 175. Dirt within the pump room



Site Photo 176. Electrical wires on the ground

## Appendix E. Work in Progress/Work Partially Completed

---

Since Parsons' contract was terminated, there is no work in progress; however, several buildings were partially constructed prior to the termination.

### Central Laundry Facility

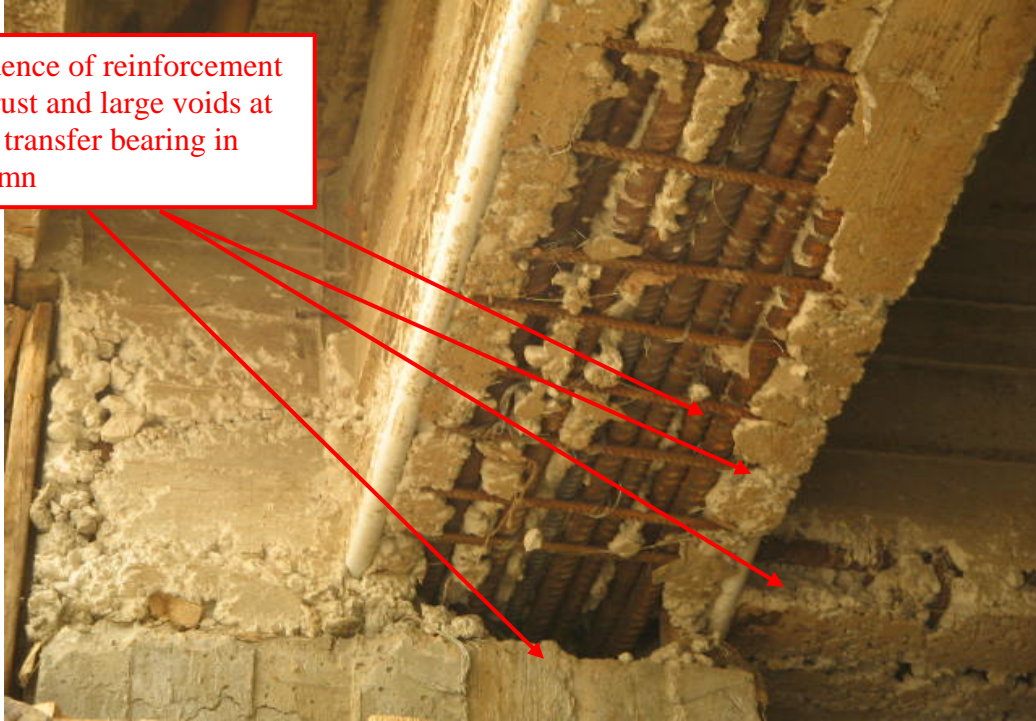
TO 06 required the construction of a central laundry facility. The central laundry facility was to provide general laundry services to all BPC cadets and instructors. According to the design drawings, the central laundry facility was a single-story building (Site Photo 177) with individual rooms for receiving, delivery, equipment, lockers, kitchenette, offices, showers, lavatories, and female toilets. During our site visit, we identified the following deficiencies:

- areas of severe reinforcement bar exposure on the surface of the load-bearing reinforced concrete ceiling beams (Site Photos 178-180)
- areas of severe concrete segregation, honeycombing, and voids (Site Photos 181-183)
- poor quality brick masonry workmanship (Site Photos 184-187)

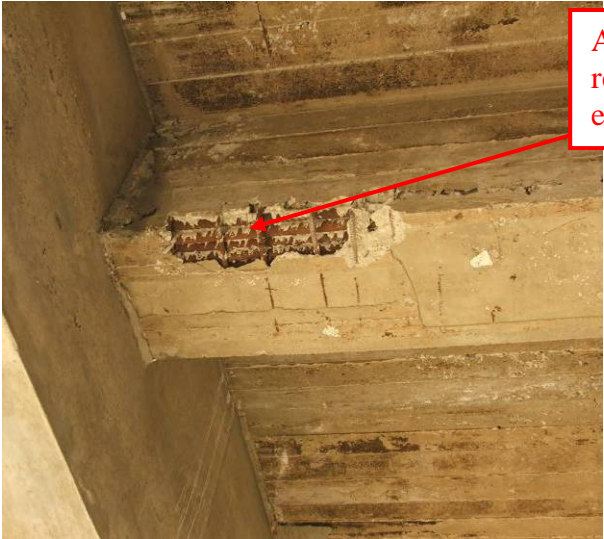


**Site Photo 177. Exterior view of the central laundry facility**

Evidence of reinforcement bar rust and large voids at load transfer bearing in column

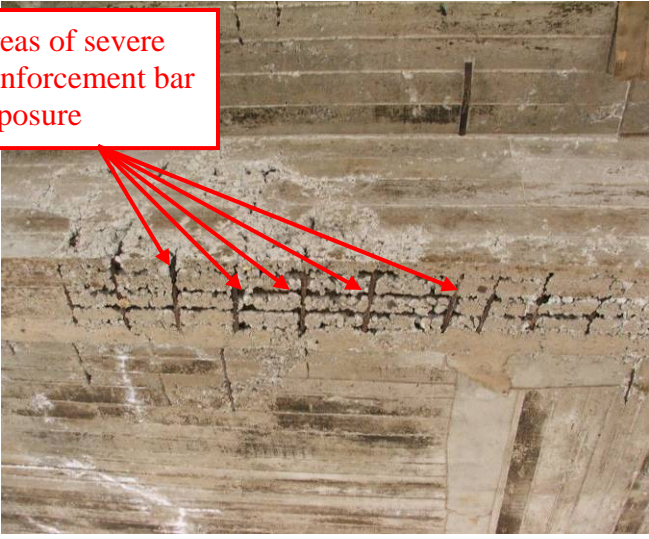


Site Photo 178. Construction deficiencies within the central laundry facility



Site Photo 179. Reinforcement bar exposure

Areas of severe reinforcement bar exposure

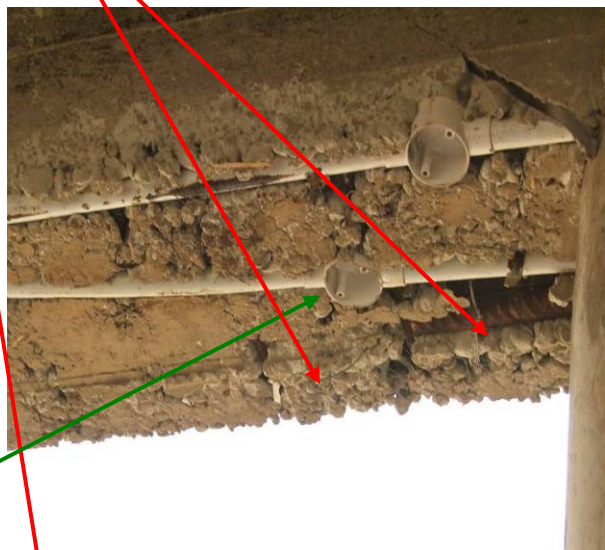


Site Photo 180. Reinforcement bar exposure

Areas of honeycombing, voids, and segregation



Site Photo 181. Concrete segregation and electrical conduit exposure

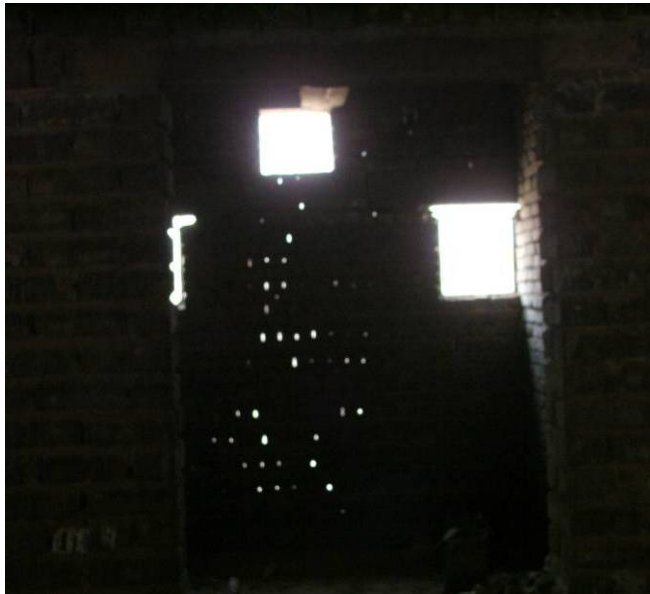


Site Photo 182. Concrete segregation and electrical conduit exposure

Electrical conduit exposure



Site Photo 183. Concrete voids and electrical conduit exposure



**Site Photo 184. Sunlight passing through gaps in wall**



**Site Photo 185. One inch gap between bricks**



**Site Photo 186. Example of poor brick workmanship**



**Site Photo 187. Example of poor brick workmanship**

A Notice To Proceed (NTP) for the central laundry facility was granted on 1 February 2005, with a completion date of 15 August 2005. According to GRD documentation, on 23 October 2005, the Parsons' site engineer discovered deficiencies in concrete structural members. Specifically, there was "...evidence of several construction deficiencies, including lack of consolidation, 'honeycombing,' inadequate concrete coverage of reinforcing steel, and improperly placed electrical conduit." Parsons notified the USACE GRD on 24 October 2005 of its concerns with the central laundry facility. Parsons was concerned that:



- Inadequate concrete cover for reinforcing steel and improperly embedded electrical conduit “potentially lends to spalling, de-lamination and reinforcing steel corrosion, which ultimately could cause structural failure.”
- Inadequate cover for reinforcing steel may “create a condition in which the reinforcing steel is subject to corrosive action from the humidity and chemical-use associated with laundry facility operations. Potential corrosion of the re-steel may lead to slab inability to bear roof load and eventual structural failure.”

Parsons initiated two independent structural analyses to determine the course of action. According to GRD documentation, the results of the analyses concluded that the deficiencies “may be corrected through repair techniques.” In addition, the subcontractor “indicated their acceptance of contractual liability and confirmed responsibility to conduct repair and/or replacement as directed.” The document continued with the following:

*“ subcontractor agreed that they would take financial responsibility for the engineering fix, but insisted that we allow them to load test the facility and determine whether complete or partial demolition is required. Once the tests are completed, the results would indicate ‘pass’ or ‘fail’ and the engineering solutions identified herein can be implemented. We are of the opinion that the tests will result in a failure mode, but should be done in order to minimize financial costs to the US Government.”*

Two options were identified to potentially correct the deficiencies:

- removing the existing concrete slab, performing the column and beam repairs, preparing the forms, and completing the elevated concrete placement
- considering a new truss design

Parsons estimated that the costs to implement Option 1 would be “borne by the subcontractor provided the load tests results were negative. The subcontractor will incur increased costs for demolition of beams/slabs and new construction which are estimated to be about \$250,000 (at no increased cost to Parsons or the government). The cost impact for Option 2 is considered the same as under Option 1 assuming the load tests are negative.”

According to GRD representatives, a potential resolution to the problem was agreed to; however, the fix would cost too much money and take too long to complete, so the central laundry facility was de-scoped. GRD did not pursue the subcontractor for the costs incurred for the partially completed central laundry facility, even though the subcontractor accepted responsibility for the poor construction. Therefore, GRD did not seek the return of \$348,332 paid to Parsons for this structure.

In addition, since a fix was potentially possible, GRD representatives do not consider the partially built central laundry facility an “imminent danger” to the BPC occupants; consequently, GRD stated that they cannot direct the subcontractor to demolish the building without incurring a cost against the government. However, internal documents indicated that this resolution was not agreed upon by GRD. For example, a response to the proposed retrofit of the central laundry facility stated “in summary, the proposed retrofit for the Central Laundry is not acceptable for structural, constructability, and safety reasons.” In addition, Parsons, in December 2006, stated the subcontractor “made no valid effort to rectify the deficiencies in an acceptable manner and have left a facility that is structurally unsafe and as a result must be demolished.”

Finally, the MNSTC-I, in order to have a laundry facility for the BPC cadets and instructors, funded its own laundry facility, which is currently under construction and should be completed by December 2006. However, because BPC representatives are concerned about the structural integrity of the existing central laundry facility “shell” and the potential for an injury to BPC cadets and instructors, MNSTC-I will pay its contractor approximately \$100,000 to demolish the building.

### Indoor Dining Facility

TO 06 required the construction of a new dining hall to seat a minimum of 1,500 cadets per shift, four shifts per meal, and to attach a new kitchen. In addition, the TO called for a cash collection system in order to accommodate any customers who would be paying to eat at the facility. BPC representatives stated that GRD had terminated Parsons’ original partially completed indoor dining facility, and that MNSTC-I was currently funding the completion of the dining facility with its own contractor. According to GRD documentation, the dining facility was approximately 65% complete when it was de-scoped (Site Photo 188).

We viewed the dining facility in the condition it was left by Parsons – MNSTC-I’s contractor had not begun working on the facility. According to the design drawings, the dining facility was to be a single-story building with main seating area, male and female toilets, cashier areas, serving counter, staff room, and receiving area. However, the as-built drawings clearly state the size of the main seating area was sufficient for 1,440 people, not the 1,500 required by the TO. We verified that the floor and wall construction, and partial ductwork and electrical work had been completed (Site Photos 189-191). Parsons’ subcontractor left equipment and materials on site after the project was de-scoped (Site Photo 192). The new subcontractor will use the leftover material. We identified areas of reinforcement bar exposure and concrete honeycombs and segregation (Site Photo 193).



**Site Photo 188. Exterior front view of partially completed indoor dining facility**



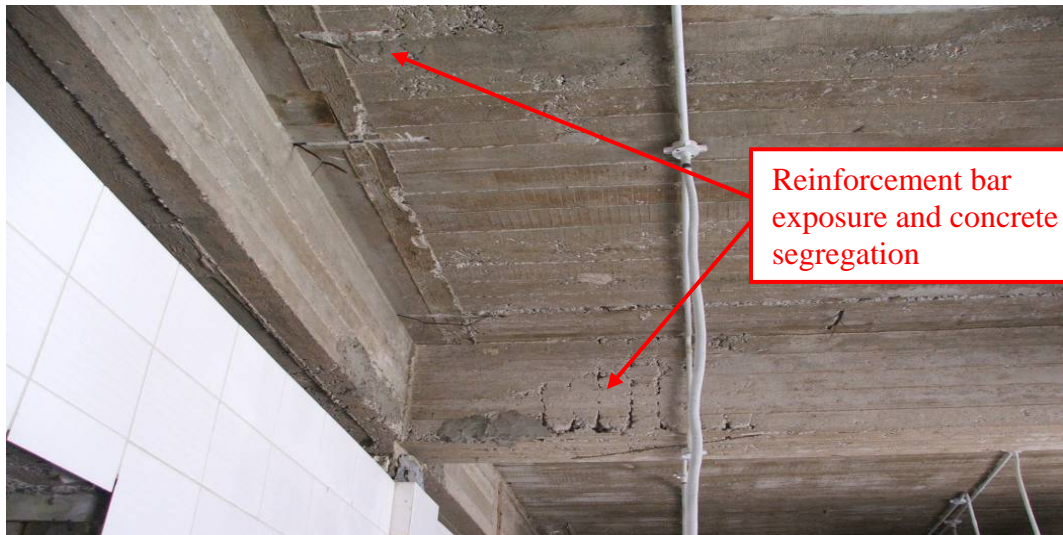
**Site Photos 189 and 190. Condition of the indoor dining facility when Parsons' contract was terminated**



**Site Photo 191. Work completed by Parsons**



**Site Photo 192. Materials left by Parsons**



**Site Photo 193. Construction deficiencies within the indoor dining facility**

Further review of the design drawings, a subsequent visit to the BPC, and discussions with BPC representatives, determined that Parsons' original design drawings did not

include the “attached” kitchen required by the TO. The government representative who reviewed Parsons’ design submittals did not mention the complete omission of the attached kitchen. GRD representatives, including the QAR did not realize the omission, either. GRD representatives believed the small room attached to the dining facility was the kitchen; however, this room is actually the receiving and servicing area for the dining facility (Site Photo 194 and Figures 14 and 15). No comment or clarification regarding this issue was raised at the time of design review. When the dining facility is completed, food will have to be brought in from the existing kitchen located on the BPC grounds. GRD representatives are now attempting to locate funding to construct a kitchen for the dining facility.



**Site Photo 194. Exterior rear view of indoor dining facility**

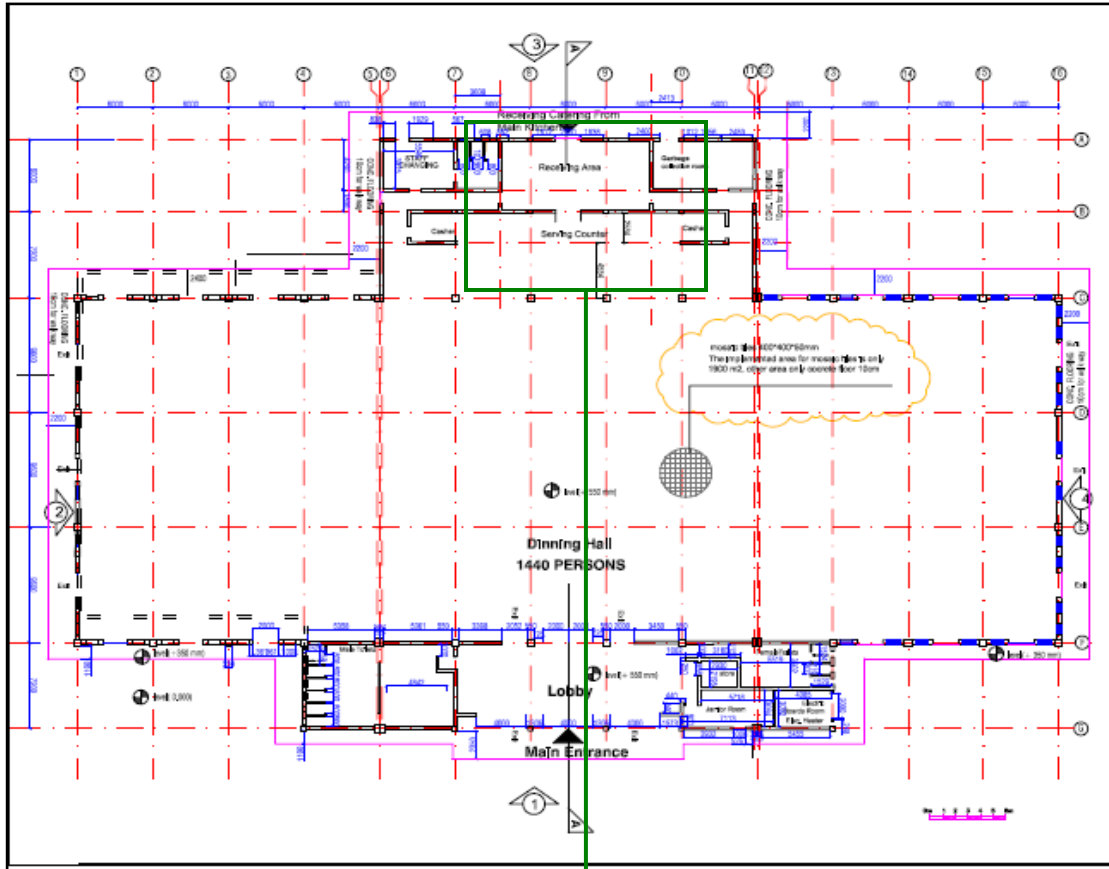


Figure 14. As-built drawing for the dining hall with no attached kitchen

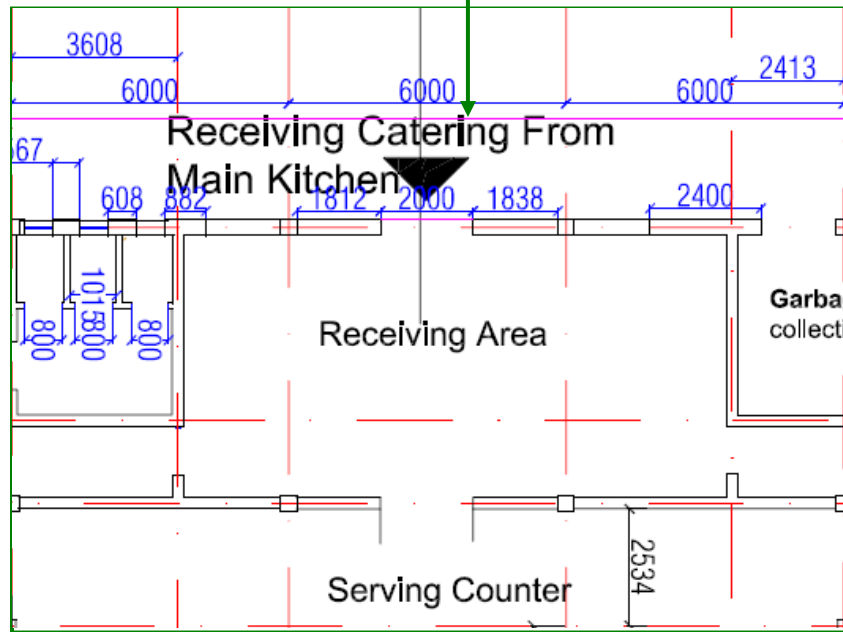


Figure 15. Enlarged view of the area GRD thought was the attached kitchen, which turned out to be the receiving area

## Communications Building

TO 29 required a communications building to accommodate the central radio dispatch, telephone system, and computer operations. According to the design drawings, the communications building was a single-story building with a large command center room, kitchenette, rest room, reception area, male and female toilets, and several miscellaneous rooms. At the time of the site visit, BPC representatives stated the communications building was only partially completed prior to it being de-scoped in May 2006. Site Photos 195 and 196 show the communication building's partially complete exterior and interior. At the time of this report, it was unknown if this building will ever be completed or eventually demolished.



**Site Photo 195. Exterior view of the partially completed communications building**



**Site Photo 196. Interior view of the partially completed communications building**

## Physical Training Field

TO 06 required the construction of a physical training (PT) field, complete with pull-up bars, mats, etc. According to BPC representatives, the PT field was excavated and a foundation with reinforcement bars was partially completed. GRD officially de-scoped this project and it was not completed. The foundation was partially covered with dirt; however, a portion of the reinforcement bar still extends beyond the dirt covering (Site Photos 197 and 198). BPC representatives are concerned about the safety of its cadets and instructors, specifically a cadet/instructor tripping over an exposed reinforcement bar and impaling himself. When GRD de-scoped this project, the responsibility for correcting the potential safety hazard of exposed reinforcement bars transferred from Parsons and GRD to the BPC officials.



**Site Photo 197. Foundation for PT field with exposed reinforcement bars extending beyond the ground**



**Site Photo 198. PT field foundation with reinforcement bars**

### Weight Training Room

TO 29 required the contractor to design, construct, and equip a 100-person weight training room with lockers, showers, free weights, and total fitness machines. According to BPC representatives, the contractor began the foundation work then the project was de-scoped (Site Photo 199). Similar to the PT Field, BPC representatives are concerned about the fact that the de-scoped project left exposed reinforcement bars on the campus, with the responsibility for correcting the problem left to the BPC.



**Site Photo 199. Partially completed weight training room, with reinforcement bar exposure**

### Refurbish Dog Kennels

TO 29 required the refurbishment and expansion of the existing dog kennels, including new air conditioning units and upgraded electrical service. BPC representatives stated the only work completed in the dog kennels was electrical work. Apparently, a major electrical fire occurred previously in the facility. According to GRD records, Parsons completed “Emergency Work” for the facility. We identified the work completed by Parsons (Site Photos 200 and 201), which consisted of re-wiring the electrical panel. During our site visit on 1 December 2006, we were unable to determine the incoming voltage and amperage of the power cables, as well as, the demand load of the service lines connected. We have not seen any new electrical feed(s) to a new breaker box(es) or any breakers or branch distribution at this location.

We observed old multiple service lines connected to the existing main power feed without any required power panel or circuit breakers. Circuit breakers provide safety to people and equipment by offering the opportunity of a mechanical shut down from the surge in incoming power as well as over loading the branch circuit. However, the safety and appropriateness of the electrical work is questionable. For example, the contractor failed to use a circuit breaker and instead wired the incoming heavy amp line directly to the lower amp lines, which significantly increases the chance of an additional electrical fire.





**Site Photo 200. “Emergency” electrical work performed by Parsons**



**Site Photo 201. Close-up view of Site Photo 200.**

## Appendix F. Systemic Problems with BPC Buildings

---

Our initial inspection report dealt specifically with plumbing issues identified in the cadet barracks buildings. Our report recommended GRD perform an assessment of all waste water plumbing installation in all newly constructed buildings, both single and multiple storied, sponsored under this contract to determine if similar methods of inadequate plumbing practices were utilized in other project locations as those discovered in the cadet barracks buildings. The report also recommended a critical technical study of the structural integrity and load carrying capacity as well as the potential environmental and health hazards posed by the rust, mold, and presence of urine and fecal matter within the concrete floor slabs of the cadet barracks buildings.

GRD hired a professional engineering firm to perform the structural assessment required by our inspection report. The report concluded that the “concrete slabs under the bathrooms are structurally sound,” but recommended the repair of any sewer leakage to “accommodate the structure’s intended use and to maintain the overall structural stability with time.”

The results of the assessment report documented the “improper installation of roof flooring” for all classroom buildings, range control building, library, instructor barracks, language instructor barracks, forensic lab building, workshop building, and motor pool building. Specifically, “most of the roof mastic areas need to be repaired, maintained and corrective action must be taken to slope the concrete tiles [and] the drain openings.” GRD representatives confirmed that the roofs were poorly constructed for most BPC buildings. Poor mastic work is shown in Site Photo 202; while the end result of the poor work is shown in Site Photos 203 and 204.



Site Photo 202. Example of poor mastic work on the roof



**Site Photo 203. Interior damage caused by leaking tar**



**Site Photo 204. Interior damage caused by leaking tar**

## Appendix G. Work Completed Since Initial Site Visit

---

### Repair of Cadet Barracks Plumbing

During a meeting with GRD, GRC, MNSTC-I, BPC, and SIGIR personnel on 11 September 2006, GRD representatives acknowledged responsibility for resolving the waste water plumbing problem within the barracks; while agreeing that the plumbing issue had to be resolved by 22 October 2006 when the BPC would be at full capacity. On 1 November 2006, GRD representatives told SIGIR that the subcontractor had dug up the concrete, replaced the poorly installed plumbing, finished the floors for the cadet barracks buildings, and cadets were occupying the buildings.

We visited the BPC on 10 November 2006 to verify the work accomplished on the cadet barracks buildings. We immediately noticed water on the ground floor common area (Site Photo 205). We observed water leaking from the ceiling (Site Photos 206 and 207) at approximately the same pace as documented in our previous report. We also noticed leaking water in the same locations on the pipes (Site Photos 208 and 209). [NOTE: the waste water damage to the current pipes is less than the damage from our original site visit; however, the current pipes had only been used for a few weeks.] BPC cadets stated the water had been leaking for approximately 4-5 days by the time of our visit. The cadets put a bucket under an open section of the false ceiling to capture leaking water (Site Photos 210 and 211).



**Site Photo 205. Leaking water on floor of the cadet barracks common area room**



**Site Photo 206. Water leaking from ceiling of cadet barracks**



**Site Photo 207. Close-up view of the water leaking from the ceiling of Site Photo 206**



**Site Photo 208. Effect of leaking waste water on plumbing pipes**



**Site Photo 209. Effect of leaking waste water on plumbing pipes**

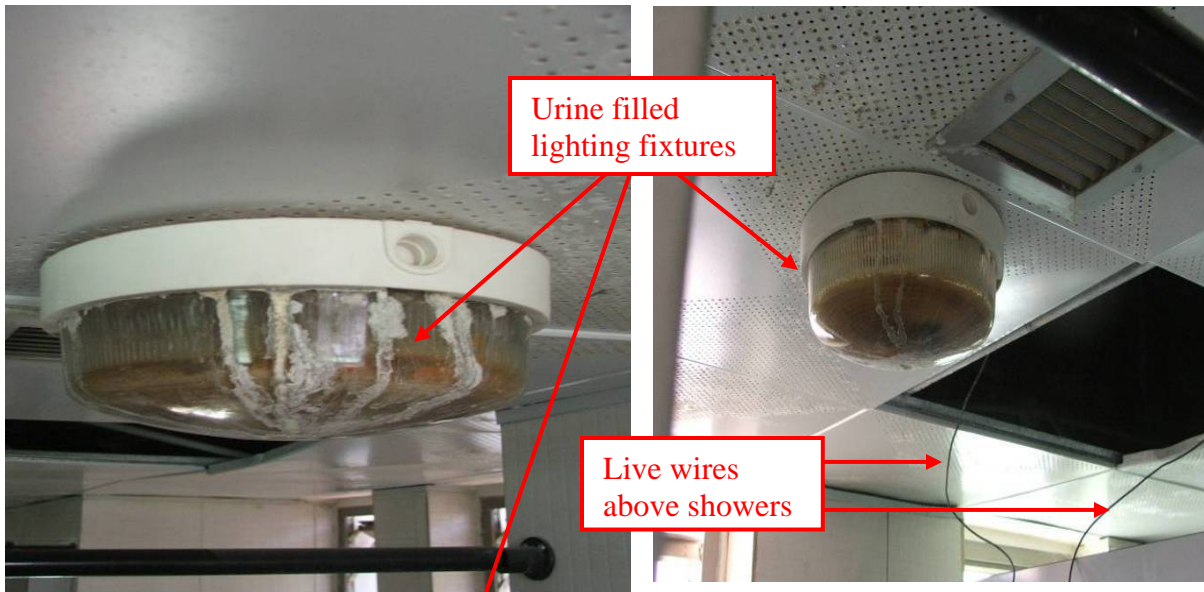


**Site Photo 210. Total accumulation of leaking water in cadet barracks**



**Site Photo 211. Close-up of bucket full of leaking water**

We continued our visit to the barracks first floor bathroom where we found more evidence that the subcontractor had not properly corrected the previously identified plumbing deficiencies. In some instances, it does not appear the subcontractor even replaced ceiling lights and false ceiling panels (Site Photos 212-215). Several ceiling lights were full of urine and fecal matter and corroded on the outside, which appeared to be more than a few weeks old; while the crystallized urine stains on the false ceiling panels appeared to be similar to the panels that were seen on our first visit to the BPC. However, BPC representatives were told by the GRD and the subcontractor that the entire barracks were complete. Not only were the upstairs bathrooms not complete, in some cases, potential hazards existed. For example, above the showers, live wires are dangling through exposed areas of the false ceiling with light fixtures filled with urine and water leaking from the sewer pipes (Site Photos 216 and 217).



**Site Photo 212. Urine-filled ceiling light**

**Site Photo 213. Urine-filled ceiling light and live wires**



**Site Photo 214. Urine-filled ceiling light**



**Site Photo 215. Crystallized urine stains on ceiling panels**





**Site Photo 216. Wires taped together**

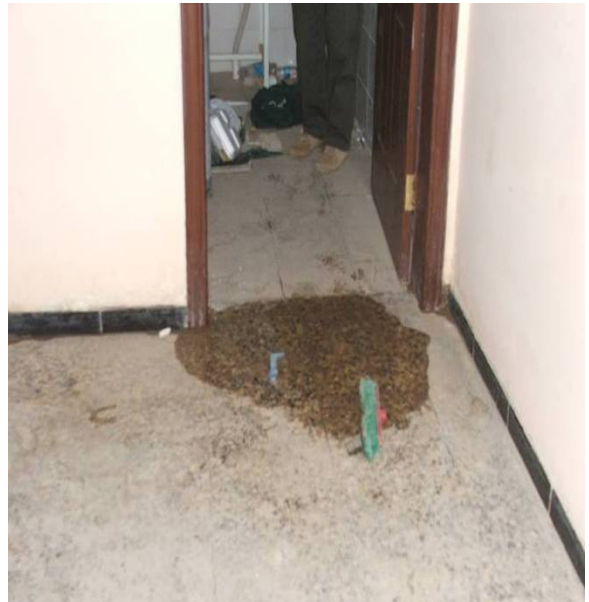


**Site Photo 217. Wires taped together**

In another barracks building, we identified water leakage on a smaller scale than the previous barracks building. However, we noticed damage from the water leakage on the floors (Site Photos 218 and 219), walls, doorframes, and doors (Site Photos 220 and 221).



**Site Photo 218. Water damage on the floor of the cadet barracks**



**Site Photo 219. Additional water damage in cadet barracks**



**Site Photo 220. Door frame and door damage resulting from water leaks in cadet barracks**



**Site Photo 221. Enlargement of Site Photo 220**

### Repair of Classroom Building Plumbing

Earlier in this report, we documented damage from water leakage, poor door installation, and the ground floor sloping downward to the right in Classroom Building E. We visited Classroom Building E on 10 November 2006 to review the work completed by the subcontractor. The plumbing issues in the male bathroom appeared to have been corrected; however, in the female bathroom we witnessed evidence of water leakage on the false ceiling panels (Site Photo 222) and where the false ceiling panels collapsed and sent debris and water to the floor (Site Photos 223 and 224).



**Site Photo 222. Water damage on ceiling panels**



**Site Photo 223. Damaged ceiling panels that fell to the ground**



**Site Photo 224. Close-up of Site Photo 223**

The subcontractor replaced the ground floor to correct the downward slope earlier identified (Site Photos 225 and 226). The new floor did not have the significant downward slope; however, the subcontractor did not correct the poor doorframe installation. The doorframe was originally constructed when the floor sloped and no corrective actions were taken to adjust the doorframe. Consequently, the door does not properly shut (Site Photo 227).



Floor sloped approximately 4" to the right



New floor not sloped

Site Photo 225. View of sloped floor in Classroom E

Site Photo 226. View of corrected floor



Door does not shut – it hits the doorframe

Site Photo 227. Door in Classroom E will not close completely since the floor was replaced

## Appendix H. Award Fees

Period Ending Dec 04		Approximate % Complete		Available Pool	Awarded	Not Awarded	% of Pool Awarded
TO-6		<25%		\$ -	\$ -	\$ -	N/A
TO-29		>25%		\$ 1,563,520.00	\$ 1,328,992.00	\$ 234,528.00	85.0%
				<b>\$ 1,563,520.00</b>	<b>\$ 1,328,992.00</b>	<b>\$ 234,528.00</b>	<b>85.0%</b>
Period Ending March 05		% Complete - Contractor	% Complete - Government	Available Pool	Awarded	Not Awarded	% of Pool Awarded
TO-6		43%	42%	\$ 1,499,208.00	\$ 1,160,916.00	\$ 338,292.00	77.4%
TO-29		35%	42%	\$ -	\$ -	\$ -	N/A
<b>Total</b>				<b>\$ 1,499,208.00</b>	<b>\$ 1,160,916.00</b>	<b>\$ 338,292.00</b>	<b>77.4%</b>
Period Ending Sept 05		% Complete - Contractor	% Complete - Government	Available Pool	Awarded	Not Awarded	% of Pool Awarded
TO-6		59%	68%	\$ 1,454,063.00	\$ 685,882.00	\$ 768,181.00	47.2%
TO-29		68%	67%	\$ 781,760.00	\$ 392,513.00	\$ 389,247.00	50.21%
<b>Total</b>				<b>\$ 2,235,823.00</b>	<b>\$ 1,078,395.00</b>	<b>\$ 1,157,428.00</b>	<b>48.2%</b>
Period Ending March 06		% Complete - Contractor	% Complete - Government	Available Pool	Awarded	Not Awarded	% of Pool Awarded
TO-6		79%	80%	\$ 0.00	\$ N/A	\$ N/A	N/A
TO-29		87%	81%	\$ 0.00	\$ N/A	\$ N/A	N/A
<b>Total</b>				<b>\$0.00</b>	<b>N/A</b>	<b>N/A</b>	<b>N/A</b>
Period Ending Sept 06 (Final Pool)		% Complete - Contractor	% Complete - Government	Available Pool	Awarded	Not Awarded	% of Pool Awarded
TO-6		100%	100%	\$ 984,424.00	TBD	TBD	TBD
TO-29		100%	100%	\$ 781,760.00	TBD	TBD	TBD
<b>Total</b>				<b>\$ 1,766,184.00</b>			
Total Award Fee Pool (12%)			Total Available Pool	Total Available Pool to Date	Awarded to Date	Not Awarded to Date	% of Pool Awarded to Date
TO-6			\$ 3,937,695.00	\$ 2,953,271.00	\$ 1,846,798.00	\$ 2,090,897.00	46.9%
TO-29			\$ 3,127,040.00	\$ 2,345,280.00	\$ 1,721,505.00	\$ 1,405,535.00	55.1%
<b>Total</b>			<b>\$ 7,064,735.00</b>	<b>\$ 5,298,551.00</b>	<b>\$ 3,568,303.00</b>	<b>\$ 3,496,432.00</b>	<b>67.3%</b>

# Appendix I. Complete Text of GRD Comments



REPLY TO  
ATTENTION OF

DEPARTMENT OF THE ARMY  
U.S. ARMY CORPS OF ENGINEERS  
GULF REGION DIVISION  
BAGHDAD, IRAQ  
APO AE 09316

CEGRD-CG

5 January 2007

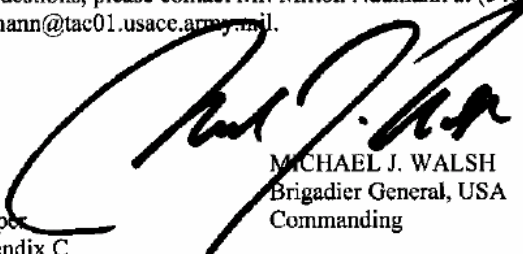
MEMORANDUM FOR Special Inspector General for Iraq Reconstruction, US Embassy Annex,  
M-202, Old Presidential Palace, APO AE 09316

SUBJECT: Draft SIGIR Project Assessment Report – Baghdad Police College (PA-06-078.2  
and PA-06-079.2)

1. This memorandum provides the U.S. Army Corps of Engineers, Gulf Region Division response to the subject draft project assessment report.
2. It is important to note that the strategic and urgent need to quickly provide a training capability for the Iraqi Police has been achieved. Despite some identified shortfalls in workmanship of the sewer, water and electrical infrastructure of the facilities, not one graduation has been delayed, nor has a single class of cadets been delayed. Since June 2006, six classes, totaling about 4,000 cadets, graduated from the Baghdad Police College. Additionally, about 1,000 officer trainees are currently attending their first year of a 3-year program.
3. The Gulf Region Division (GRD) has directed and overseen correction of many deficiencies, including the replacement of the sewage and drainage systems in the restrooms of all cadet barracks. GRD will continue to staff an onsite team of field engineers to monitor warranty repair work and resolve warranty issues through April 2007.
4. While GRD generally concurs with the conclusions contained in the draft report, GRD does not concur with all the recommendations. GRD is providing additional information that adds clarity to the report. See the enclosure for our direct responses to the recommendations and additional comments. Enclosure 2 provides an information paper on cost-plus contracts. Enclosures 3 and 4 provide corrections to Appendixes C and H of the draft report.
5. If you have any questions, please contact Mr. Milton Naumann at (540) 665-5021 or his email Milton.L.Naumann@tac01.usace.army.mil.

Enclosures

1. Command Reply
2. Cost-Plus Info Paper
3. Corrections, Appendix C
4. Corrections, Appendix H



MICHAEL J. WALSH  
Brigadier General, USA  
Commanding

# Appendix I. Complete Text of GRD Comments

## COMMAND REPLY

to

### SIGIR Draft Assessment Report – Baghdad Police College PA-06-078.2 and PA-06-079.2

1. **Background.** Iraq reconstruction and humanitarian relief spans a program encompassing more than 10,000 projects ranging from condolence payments to renovations; construction; rebuilding minor and major facilities; and repair and construction of minor and major sewage, water, electrical, and oil infrastructure. Additionally, establishing military camps required a significant level of military construction (MILCON), contingency construction authority, and OMA funded construction to provide quality work and life support facilities. Overall the Gulf Region Division's share of this immense workload consisted of more than 3,000 projects during a 3-year period—a period of transitional governments, violence, military and civilian personnel transitions and a very austere environment. Despite the challenging environment, reconstruction and construction successfully progressed to improve the health, welfare and quality of life for the Iraqi people, Iraqi Security Forces and the Coalition Forces.

Unfortunately, through a myriad of events, the Baghdad Police College does not represent a success story for construction, but it does represent a huge success story for the training and development of the Iraqi Police. Not one graduation has been delayed, nor has a single class of American-trained or Iraqi-trained cadets been delayed. Since June 2006, six classes, totaling about 4,000 cadets, have graduated from the Baghdad Police College. Additionally, about 1,000 officer trainees are currently attending their first year of a 3-year program at the Baghdad Police College. Furthermore, the Baghdad Police College Dean recently demanded an accelerated graduation schedule for the last class of American-trained cadets. Through a combined effort, a 10 week class was graduated in only 8 weeks.

To facilitate the tremendous urgency to rapidly train and develop the Iraqi Police, the U.S. government placed a large measure of trust in the contractor in the areas of project planning, design and quality control using a design-build cost-plus contract. Enclosure 1 provides an information paper on cost-plus contracts. The environment and developing requirements necessitated this course of action. In September 2006, GRD conducted an internal investigation into the management and execution of the Baghdad Police College project. Investigative findings determined that both the contractor and government did not fully ensure standards of construction and quality workmanship of facility infrastructure were executed. The contractor did not adequately manage the project or develop the designs. Additionally, the contractor failed to correct identified deficiencies and to construct according to established international standards. Conversely, the government did not provide sufficient quality assurance, ensure the contractor took corrective actions, and follow-up to ensure the contractor provided adequate designs.

Enclosure 1

# Appendix I. Complete Text of GRD Comments

## **Command Reply to SIGIR Draft Assessment Report Baghdad Police College PA-06-078.2 and PA-06-079.2**

---

Despite some identified shortfalls in workmanship of the sewer, water and electrical infrastructure of the facilities, the facilities have been turned over for use. Deficiencies noted are corrected through the use of established warranties that have enabled the government to improve those facilities already in use.

2. **SIGIR Recommendation and Gulf Region Division Comments.** The Commanding General, U.S. Army Corps of Engineers, Gulf Region Division should:

**Recommendation 1.** Require the contractor to replace all existing plumbing fixtures and fittings in all newly constructed buildings to comply with the International Plumbing Code in accordance with contract specifications. Specifically, eliminate the use of cemented joints, abnormal fittings, and improperly sealed pipe connections. In addition, require the use of cleanouts, traps, and proper sealing techniques.

**Actions Taken.** Non-Concur. Task orders 6 and 29 were terminated for convenience. GRD continues to require repair of previously identified systemic problems, such as improperly connected plumbing fixtures, under warranty by working with the subcontractors. GRD will continue to staff an onsite team of field engineers to monitor warranty work and resolve warranty issues.

**Recommendation 2.** Require the U.S. Army Corps of Engineers Gulf Region Central Quality Assurance Representatives to be responsible for identifying quality issues as required by the contract and USACE ER 1180-1-6, instead of simply tracking project progress.

**Actions Taken.** Concur. The government's Quality Assurance Representatives' responsibilities are to track project progress and ensure that construction quality issues are properly documented and resolved timely. GRD will reinforce this requirement to all Quality Assurance Representatives. GRD instituted recurring quality assurance representative and contractor representative training to provide basic level skills for quality assurance representatives.

**Recommendation 3.** Require the U.S. Army Corps of Engineers Quality Assurance Representative to become thoroughly familiar with the International Plumbing Code standards.

**Actions Taken.** Non-Concur. In accordance with ER 1180-1-6, the contractor is responsible for all activities necessary to manage, control and document work to ensure compliance with the contract plans and specifications. The USACE QAR is responsible for implementing and enforcing the activities specified in ER 1180-1-6, paragraph 7.c. Quality assurance representatives should understand the design requirements. To validate the contractor's work, the quality assurance representative will review the contractor's quality control program to ensure the contractor uses competent personnel and conducts proper testing.



# Appendix I. Complete Text of GRD Comments

## **Command Reply to SIGIR Draft Assessment Report Baghdad Police College PA-06-078.2 and PA-06-079.2**

---

**Recommendation 4.** Require the U.S. Army Corps of Engineers Project Engineer and Quality Assurance Representative to supervise the contractor's installation of all plumbing rework to ensure compliance with the International Plumbing Code.

**Actions Taken.** Non-Concur. The contractor is responsible for all contract work. In accordance with ER 1180-1-6, the contractor is responsible for all activities necessary to manage, control and document work to ensure compliance with the contract plans and specifications. The USACE QAR is responsible for implementing and enforcing activities specified in ER 1180-1-6, paragraph 7.c. The GRD onsite engineering team will observe the sub-contractor's installation of plumbing rework to be accomplished under existing warranties to ensure compliance with the contract plans and specifications. As site visits are completed, the quality assurance representatives will document their observations on daily quality assurance reports.

**Recommendation 5.** Require the U.S. Army Corps of Engineers Gulf Region Division Resident Engineer to thoroughly review the contractor submitted as-built drawings. Specifically, walk through each facility and compare the as-built drawings to the actual construction completed.

**Actions Taken.** Concur. GRD will coordinate a prioritized review of available contractor's as-built drawings to determine if they are accurate and satisfactory. GRD will update these drawings to the extent possible while completing warranty work in affected buildings.

**Recommendation 6.** Require the contractor to resubmit, at no cost to the Government, accurate as-built drawings for any deviations noted during the walk through of the facility.

**Actions Taken.** Non-Concur. Under a cost plus contract, the U.S. government cannot legally require the contractor to resubmit drawings at no cost. In response to previous requests, the prime contractor has refused to resubmit as-built drawings without receiving additional funds for this work. There are no additional funds for this project.

**Recommendation 7.** After completing the thorough review of the as-built drawings, verify the contractor's individual charges against the confirmed work performed. Determine if the contractor was paid for work claimed but not performed. Specifically, determine if the contractor charged, and was paid, for engineered expansion joints in the Instructors' Barracks. If so, then recover the money paid from the contractor.

**Actions Taken.** The recommendation, as stated, would not work as the prime contract was a cost reimbursable contract and its subcontracts were firm-fixed-price. It is not a standard contractor billing practice to prepare detailed invoices for firm-fixed-price contracts; therefore, the government would not get this detail from the prime contractor on its subcontractor portion of their invoices. GRD completed a review of available contractor invoices and found that costs are billed in lump sum amounts for each type of

# Appendix I. Complete Text of GRD Comments

## **Command Reply to SIGIR Draft Assessment Report Baghdad Police College PA-06-078.2 and PA-06-079.2**

---

cost submitted on the invoice. Based on these facts, the Gulf Region Division recommends that SIGIR withdraw this recommendation. Otherwise, GRD non-concurs because the contractor was not required to invoice the US Government (USG) at a level of detail that would enable the USG to determine if the contractor charged, and was paid, for specific construction tasks.

The Gulf Region Division has coordinated with DCAA to conduct an audit of Parsons accounting and purchasing records to enable the USG to determine if the contractor was paid for work not performed. Based on DCAA's final report the USG will take appropriate action.

**Recommendation 8.** Require the U.S. Army Corps of Engineers Quality Assurance Representatives to be present for any future plumbing tests. In addition, require the Quality Assurance Representatives to document the tests performed, equipment used, and test setup information.

**Actions Taken.** Non-Concur. In accordance with ER 1180-1-6, the contractor is responsible for all activities necessary to manage, control and document work so as to ensure compliance with the contract plans and specifications. The USACE QAR is responsible for implementing and enforcing activities specified in ER 1180-1-6, paragraph 7.c. GRD will ensure that the subcontractor gives sufficient notice of future plumbing tests so that GRD can arrange for a quality assurance representative to witness the tests and verify the test results. Quality assurance representatives will document their observations made during site visits on daily quality assurance reports.

**Recommendation 9.** Require the Project Engineer and Quality Assurance Representative to review the 95 Nonconformance Reports submitted by Parsons for construction deficiencies and determine if corrective actions were previously taken. If corrective actions were not taken, require that necessary corrective actions be taken.

**Actions Taken.** Concur. GRD now has the 95 Nonconformance Reports and will review them. Any corrective actions will be accomplished to the extent possible while completing warranty work in affected buildings.

3. **Additional Comments.** The Gulf Region Division provides the following specific comments related to the draft report:

- a. **SIGIR Statement.** Pages 8-10, "Design and Specification Review Process".

Page 8, Paragraph 2. "However, the PCO did not have a submittal process in place to review Parsons' designs.

Paragraph 3, "The PCO representative also stated that he was...concerned the drawings are not accurate."

# Appendix I. Complete Text of GRD Comments

## **Command Reply to SIGIR Draft Assessment Report Baghdad Police College PA-06-078.2 and PA-06-079.2**

---

Paragraph 5, "Also on 10 January 2005, the Government reviewer commented that the electrical drawings for the motor pool were not complete."

Page 10, Paragraph 1, "Further when drawings were submitted, they were largely rejected by the PCO for being incomplete, inaccurate, and substandard."

Paragraph 3, "...as built drawings provided for water distribution do not match the existing field conditions in terms of location, construction and materials."

Paragraph 4, "The contractor's drawings lacked significant and basic design details, such as the rough-in and finish-out for the installation of plumbing fixtures ...."

Paragraph 4, "Further, there was a significant omission with regards to the location and correct type of building expansion joints."

**GRD Comments.** The design-build concept allows contractors to provide an experienced design and construction team including Quality Control staff. It is the responsibility of the contractor to provide adequate designs. With the Baghdad Police College, the design-build contractor failed in the design responsibilities by routinely submitting incomplete drawings, which government reviewers returned. Typically, the design-build contractor did not address these comments. Furthermore, with the overreaching emphasis on construction progress, design-build construction was ongoing while the contractor was unresponsive in providing timely and complete design submittals.

b. **SIGIR Statement.** Page 24, "Inexplicably, GRD did not pursue the recovery of costs incurred for the partially completed central laundry facility, even though the subcontractor accepted responsibility for the poor construction. GRD did not seek the return of \$348,332 paid to Parsons for this structure."

**GRD Comments.** Under a cost-plus contract, the government bears the cost of work, regardless of degree of completion of a project. The Government reduced the rate of expenditure of project funds by de-scoping the central laundry facility thereby reducing costs the Government would have been responsible for under the Parsons cost-plus contract and freeing up funds for the remainder of the project. GRD was unable to recover costs incurred for the partially completed central laundry facility because, under a cost-plus contract, the Government is liable for incurred costs unless the contractor commits fraud, intentionally disregards contract requirements, or was grossly negligent.

c. **SIGIR Statement.** Page 33, first paragraph after bulleted list: "GRD and Parsons representatives believed a building without an operating fire alarm system was acceptable for turnover to the BPC and ready for occupancy by the cadets."

# Appendix I. Complete Text of GRD Comments

## **Command Reply to SIGIR Draft Assessment Report Baghdad Police College PA-06-078.2 and PA-06-079.2**

**GRD Comments.** It is not GRD's policy to turn over buildings without functioning fire alarm system. Furthermore, there is no basis for SIGIR's statement since GRD identified the deficiency in a punch list.

d. **SIGIR Statement.** Page 66, "Base and Award Fees", Paragraph 2, "The Awards Fee Board has not met for this time period [September 2005 – September 2006]."

**GRD Comments.** This statement is inaccurate. On 3 May 2006, the Awards Fee Board presented its recommendations to the Award Fee Determining Official to discuss the performance period September 2005 through March 2006. No award fee was given the contractor for any task order during that period. More specifically, Task Orders 6 and 29 were not eligible for award fee during this period based on lack of progress at the Baghdad Police College. The Award Fee Board has not yet met for the period after March 2006.

e. **SIGIR Statement.** Page 73, Appendix B, "Contract, Task Orders and Modifications", Bullet 1. "Modification #P00001, issued 3 August 2004, included the language for processing invoices."

**GRD Comments.** The statement should read "Modification #P00001, issued 6 April 2004, transferred contracting officer authority".

f. **SIGIR Statement.** Page 75, Appendix B, "Contract, Task Orders and Modifications", Bullet 10. "Modification 11, dated 4 April 2006,...."

**GRD Comments.** The correct date is 4 March 2006.

g. **SIGIR Statement.** Page 77, Appendix C, "De-Scoped Task Order Items".

**GRD Comments.** SIGIR excluded notes from Appendix C clarifying the table. Additionally, other corrections GRD provided earlier were not updated in the draft report. A corrected version of Appendix C (including the Notes to accompany the table)—Enclosure 2—more accurately depicts the data in the table (changes marked in red font).

h. **SIGIR Statement.** Page 119, Appendix E, "Work in Progress/Work Partially Completed": "Parsons' original design drawings did not include the 'attached' kitchen required by the TO."

**GRD Comments.** A kitchen was never part of the design for the 1,500 cadet dining facility. The contractor's Rough Order of Magnitude submittal, dated 26 May 2004, states that a "dining hall shall attach to a new kitchen" and the "existing music hall shall become new commercial grade kitchen...renovated under separate contract". In addition, the government's technical evaluation, dated 24 October 2006, states "connect kitchen to existing dining hall" and describes requirements as a structure of no more than 25 to 35 feet, basically a corridor from one point to the other. In summary, the dining

# Appendix I. Complete Text of GRD Comments

## **Command Reply to SIGIR Draft Assessment Report Baghdad Police College PA-06-078.2 and PA-06-079.2**

facility was to connect to a kitchen renovated under a separate contract. This functioning kitchen currently exists in a building almost adjacent to the new dining facility.

i. **SIGIR Statement.** Pages 127 - 131, Appendix G, "Work Completed Since Initial Site Visit" versus completed work.

**GRD Comments.** GRD repaired under warranty all items previously identified, but has discovered some items requiring re-work.

GRD has directed and overseen the replacement of the sewage and drainage systems in the restrooms of all cadet barracks buildings. These repairs included cleaning or replacing stained light fixtures and ceiling tiles, as well as, re-pouring, waterproofing and retiling the concrete floors after repairing or replacing affected piping. In some instances, GRD discovered areas requiring rework due to failed pipe joints allowing leakage from the drain system. The subcontractors repaired the identified leaks. Since the Baghdad Police College's occupancy and use of the facilities, additional repairs have been identified which are outside the scope of warranty.

Based on captions provided by SIGIR, the orientation of SIGIR's photos and the inability of inspection teams to locate similarly stained or wetted fixtures on the water closet side of any barracks restroom during three comprehensive walkthroughs conducted in November and December 2006, it appears the light fixtures identified in site photos 181, 182 and 183 are located on the shower side of the second floor restroom. Because of the arrangement of wastewater piping in the restrooms, there is no piping above the showers from which sewage can leak. A team of engineers from the Ministry of Interior, in the presence of representatives from Multi National Security Transition Command-Iraq and GRD, qualitatively determined that yellow liquid present in light fixtures of cadet barracks restrooms did not consist of urine and fecal matter, but was actually dirt-filled fresh water. Further, based on inspection of representative fixtures, these engineers also believe the crystallized deposits shown in photo 181 are salt deposits from fresh water leaking through the concrete floor above.

j. **SIGIR Statement.** Page 136, Appendix H, "Award Fees".

**GRD Comments.** The table currently in the draft report contains some blanks for the period ending March 2006. Enclosure 3 provides the missing information (in red font).

# Appendix I. Complete Text of GRD Comments

Information Paper

CEGRD-BM

5 January 2007

**SUBJECT: Cost Plus Award Fee (Reconstruction) Contracts in Iraq**

1. Purpose. To provide information on cost plus award fee (reconstruction) contracts.

2. Facts.

a. A cost-plus award fee (CPAF) is a cost-reimbursement contract that provides for a fee consisting of:

i. A base amount ("base fee") which is a fixed percentage of the original amount at inception of the contract.

ii. An award fee amount ("award fee") which is that fixed percentage of the original amount which the contractor may earn in whole or in part during performance.

b. The contractor is guaranteed to receive the amount of base fee whereas the contractor is not guaranteed to receive the award fee.

3. Implementation.

a. Award of a CPAF contract is advantageous to the Government when the work to be performed is such that it is neither feasible nor effective to devise predetermined objectives, incentive targets applicable to cost, technical performance, or schedule.

b. While the cost to complete is an estimate and may vary upward or downward, the base fee is fixed and will not fluctuate unless the Government changes the scope of the task.

c. The contractor earns the fixed base portion of the fee while the award portion is determined based upon evaluation of performance. The intended goal of award fee contracting is to motivate the contractor's performance in those areas critical to program success that are susceptible to measurement and evaluation in such areas as quality, timeliness, technical ingenuity, and cost-effective management. The base fee (profit) remains fixed even if the cost to complete the contract increases or decreases.

d. If work cannot be completed at the original cost estimate, the Government may either provide additional funds to complete or accept partial performance. The contractor's risk is that there will be no additional profit for additional costs. If work is not completed to the standard desired by the Government, the contractor's risk is the same as a cost overrun in that there will be no additional fee for additional costs but the Government must still bear the cost. The Government is only able to require a cost plus

Enclosure 2

# **Appendix I. Complete Text of GRD Comments**

CEGRD-BM

SUBJECT: Cost Plus Award Fee (Reconstruction) Contracts in Iraq

contractor to redo work at its cost if the contractor has committed fraud, intentional disregard of the contract requirements or gross negligence.

e. Example. A contract is awarded for \$10,000.00. The Base Fee is 3% and the Award Fee is up to 5%. Assuming that contractor earns the full award fee:

Base Contract	\$ 10,000.00
Base Fee	\$ 300.00
Award Fee	<u>\$ 500.00</u>
Current Total	\$ 10,800.00

The contractor required additional time to complete the "existing" requirement. This additional time equates to additional man hours and resources totaling \$5,000.00.

Revised Base Contract	\$ 15,000.00
Base Fee	\$ 300.00
Award Fee	<u>\$ 500.00</u>
Revised Total	\$ 15,800.00

Margaret A. Jones  
(540) 665-5343

## Appendix J. Acronyms

---

ACI	American Concrete Institute
ASHRAE 52	American Society of Heating, Refrigerating, Air Conditioning Standard 52
ASME	American Society of Mechanical Engineers
ASTM	American Society of testing and Materials
BPC	Baghdad Police College
CADD	Computer-Aided Design and Drafting
COR	Contracting Officer Representative
CPATT	Civilian Police Assistance Training Team
CQC	Contractor Quality Control
DQCR	Daily Quality Control Report
EP	Engineering Pamphlet
ER	Engineering Regulation
FATS	Firearms Training Simulator
FPS	Facilities Protection Service
GRC	Gulf Region Central
GRD	Gulf Region Division
HVAC	Heating, Ventilation and Air Conditioning
IAW	In Accordance With
IBC	International Building Code
IEBC	International Existing Building Code
IEC	International Electro-Technical Committee
IFC	International Fire Code
IMC	International Mechanical Code
IPC	International Plumbing Code
LN	Local National
m	Meter
MNSTC-I	Multinational Security Transition Command - Iraq
NCR	Non-Conformance Report
NTP	Notice To Proceed
PCO	Project and Contracting Office
PMO	Program Management Office



POL	Petroleum, Oil, and Lubricants
PPR	Polypropylene Random (Pressure piping for hot and cold water systems)
PT	Physical Training
PVC	Polyvinyl Chloride
QA	Quality Assurance
QAR	Quality Assurance Representative
QC	Quality Control
QCR	Quality Control Representative
RE	Resident Engineer
RMS	Resident Management System
S&J	Security and Justice
SATCO	Saudi Arabian Trading Company
SOP	Standard Operating Procedure
SOW	Scope of Work
SPMO	Sector Program Management Office
TO	Task Order
USACE	United States Army Corps of Engineers

## **Appendix K. Report Distribution**

---

### **Department of State**

Secretary of State

Senior Advisor to the Secretary and Coordinator for Iraq

U.S. Ambassador to Iraq

Director, Iraq Reconstruction Management Office

Inspector General, Department of State

### **Department of Defense**

Secretary of Defense

Deputy Secretary of Defense

Director, Defense Reconstruction Support Office

Under Secretary of Defense (Comptroller)/Chief Financial Officer

Deputy Chief Financial Officer

Deputy Comptroller (Program/Budget)

Inspector General, Department of Defense

### **Department of the Army**

Assistant Secretary of the Army for Acquisition, Logistics, and Technology

Principal Deputy to the Assistant Secretary of the Army for Acquisition,

Logistics, and Technology

Deputy Assistant Secretary of the Army (Policy and Procurement)

Assistant Secretary of the Army for Financial Management and Comptroller

Chief of Engineers and Commander, U.S. Army Corps of Engineers

Commanding General, Gulf Region Division

Auditor General of the Army

### **U.S. Central Command**

Commanding General, Multi-National Force – Iraq

Commanding General, Joint Contracting Command – Iraq/Afghanistan

Commanding General, Multi-National Corps – Iraq

Commanding General, Multi-National Security Transition Command – Iraq

Commander, Joint Area Support Group – Central

### **Other Defense Organizations**

Director, Defense Contract Audit Agency

### **Other Federal Government Organizations**

Director, Office of Management and Budget

Comptroller General of the United States

Inspector General, Department of the Treasury  
Inspector General, Department of Commerce  
Inspector General, Health and Human Services  
Inspector General, U.S. Agency for International Development  
Mission Director – Iraq, U.S. Agency for International Development

## **Congressional Committees and Subcommittees, Chairman and Ranking Minority Member**

### **U.S. Senate**

Senate Committee on Appropriations  
    Subcommittee on Defense  
    Subcommittee on State, Foreign Operations and Related Programs  
Senate Committee on Armed Services  
Senate Committee on Foreign Relations  
    Subcommittee on International Operations and Terrorism  
    Subcommittee on Near Eastern and South Asian Affairs  
Senate Committee on Homeland Security and Governmental Affairs  
    Subcommittee on Federal Financial Management, Government Information and International Security  
    Subcommittee on Oversight of Government Management, the Federal Workforce, and the District of Columbia

### **U.S. House of Representatives**

House Committee on Appropriations  
    Subcommittee on Defense  
    Subcommittee on Foreign Operations, Export Financing and Related Programs  
    Subcommittee on Science, State, Justice and Commerce and Related Agencies  
House Committee on Armed Services  
House Committee on Government Reform  
    Subcommittee on Management, Finance and Accountability  
    Subcommittee on National Security, Emerging Threats and International Relations  
House Committee on International Relations  
    Subcommittee on Middle East and Central Asia

## **Appendix L. Project Assessment Team Members**

The Office of the Assistant Inspector General for Inspections, Office of the Special Inspector General for Iraq Reconstruction, prepared this report. The principal staff members who contributed to the report were:

Angelina Johnston, Auditor

Kevin O'Connor, Audit Manager

Yogin Rawal, Professional Engineer