

WASTE WATER TREATMENT PLANT  
AL KASIK MILITARY TRAINING BASE  
AL KASIK, IRAQ

**SIGIR PA-06-074**  
**JANUARY 29, 2007**



## SPECIAL INSPECTOR GENERAL FOR IRAQ RECONSTRUCTION

January 29, 2007

MEMORANDUM FOR DIRECTOR, IRAQ RECONSTRUCTION MANAGEMENT OFFICE  
COMMANDING GENERAL, MULTI-NATIONAL SECURITY  
TRANSITION COMMAND – IRAQ  
COMMANDING GENERAL, GULF REGION DIVISION,  
U.S. ARMY CORPS OF ENGINEERS  
DIRECTOR, AIR FORCE CENTER FOR ENVIRONMENTAL  
EXCELLENCE

SUBJECT: Report on Waste Water Treatment Plant, Al Kasik Military Training Base, Al Kasik, Iraq (Report Number SIGIR PA-06-074)

We are providing this project assessment report for your information and use. We assessed the design and construction work being performed at the Waste Water Treatment Plant at the Al Kasik Military Training Base, Al Kasik, Iraq to determine its status and whether the intended objectives will be achieved. This assessment was made to provide you and other interested parties with real-time information on a relief and reconstruction project underway and in order to enable appropriate action to be taken, if warranted. The assessment team included an engineer/inspector and an auditor/inspector.

The Director, Air Force Center for Environmental Excellence concurred with the conclusions and recommendations contained in a draft of this report and implemented appropriate corrective action. As a result, comments on this final report are not required.

We appreciate the courtesies extended to our staff. If you have any questions please contact Mr. Brian Flynn at [brian.flynn@sigir.mil](mailto:brian.flynn@sigir.mil) or at 914-360-0607. For public or congressional queries concerning this report, please contact SIGIR Congressional and Public Affairs at [publicaffairs@sigir.mil](mailto:publicaffairs@sigir.mil) or at (703) 428-1100.

Stuart W. Bowen, Jr.  
Inspector General

# Special Inspector General for Iraq Reconstruction

SIGIR PA-06-074

January 29, 2007

## Waste Water Treatment Plant Al Kasik Military Training Base, Al Kasik, Iraq

### Synopsis

**Introduction.** This project assessment was initiated as part of our continuing assessments of selected reconstruction activities. The overall objectives were to determine whether reconstruction contractors were complying with the terms of their contracts or task orders and to evaluate the effectiveness of the monitoring and controls exercised by administrative quality assurance and contract officers. We conducted this project assessment in accordance with the Quality Standards for Inspections issued by the President's Council on Integrity and Efficiency. The assessment team was comprised of an engineer/inspector and an auditor/inspector.

The project objective was to plan and construct a Waste Water Treatment Plant at the Al Kasik Military Training Base, Al Kasik, Iraq, which was compliant with World Health Organization 2000 specifications. The plant would be capable of handling peak and minimum flows with sufficient storage tanks upstream and downstream to satisfy system demand.

**Project Assessment Objectives.** The objective of this project assessment was to provide real-time relief and reconstruction project information to interested parties in order to enable appropriate action, when warranted. Specifically, we determined whether:

1. Project components were adequately designed prior to construction or installation;
2. Construction or rehabilitation met the standards of the design;
3. The contractor's Quality Control and the U.S. Government's Quality Assurance programs were adequate;
4. Project sustainability was addressed ; and
5. Project results were consistent with original objectives.

**Conclusions.** The assessment determined that:

1. In general, project components were adequately designed prior to construction of the Waste Water Treatment Plant at Al Kasik Military Training Base. However, the assessment team noted that the chlorination system disinfected wastewater at the pre-filter stage where prevalent suspended solids reduced disinfection efficiency. As an alternative, a post filter stage chlorination process would have been more effective because suspended solids would have been significantly reduced before the chlorination process. In addition, the current chlorination solution (the chemical compound NaOCL) may not have been compatible for storage in the temperature extremes of the local environment.
2. Construction at the Waste Water Treatment Plant appeared to meet design standards, with two exceptions. First, the clarifier tank's sweep arm assembly was not built in accordance with the approved design documentation made available to and reviewed by the assessment team. This failure to construct the tank sweep arm to the design may have been the primary factor or a significant contributing factor

that led to a complete failure of the clarifier tank on 19 March 2006. As a result, the Waste Water Treatment Plant was operationally ineffective from 19 March 2006 to the date of the site inspection.

Second, the assessment team found that the G-3 pump station experienced a significant amount of structural fracturing and damage. Based on discussions with government officials and the assessment team's on-site observations of the fractures, the assessment team believed that inadequate soil compaction before the concrete was cast was the most likely reason for fracturing. However, it is also possible that the contractor did not tie reinforcement steel at the corner of the G-3 foundation as required before the concrete was cast. Improper steel reinforcement at the corners could have contributed to the severe fracturing. In any case, the physical failure of the concrete could result in failure of the G-3 pump station piping and pump.

3. The contractor's Quality Control and the U. S. Government's Quality Assurance programs were found to be generally effective. The contractor submitted an adequate Quality Control plan before construction was scheduled to start on 1 June 2004 that addressed key elements needed for effective quality control. For example, the Quality Control plan defined the qualifications, responsibilities, and authority of contractor and subcontractor managers. In addition, the Quality Control plan disclosed definable features of work in adequate detail. Quality Assurance activities were sufficiently documented on standardized Air Force Center for Engineering Excellence<sup>1</sup> Quality Assurance reports that were reasonably well written, descriptive, complete, and almost always supported by relevant photos. In addition, Quality Assurance reports included a "Discrepancies and Non-Compliance Items" section to monitor and track timely correction of construction deficiencies. As a result, Quality Management practices were effective and any construction deficiencies referred to in this report were not caused by generally lax or ineffective quality management practices or personnel.
4. Not all aspects of project sustainability were adequately addressed in the contract. For example, the contractor was not required to provide a sufficient inventory of backup replacements and spare parts to effectively maintain Al Kasik Waste Water Treatment Plant components in order to sustain operations. During the on-site visit, the assessment team observed several instances where components of the Waste Water Treatment Plant were inoperative because there was not an inventory of backup replacements or spare parts. Although functional at the time of the site visit, there also was an array of common components without an inventory of backup replacements or spare parts necessary to facilitate real-time component change out or repair and routine plant maintenance. This condition occurred because Task Order requirements related to project sustainability were too vague. As a result, the failure of a common component did and could continue to lead to significant disruption in Waste Water Treatment Plant operations and effectiveness.

Aside from design and construction issues raised elsewhere in this report, insufficient operational/run testing and ineffective plant operator training before turn-over were likely contributing factors to the failure of the clarifier tank . On 3 October 2006, the Contracting Officer Representative of the Air Force Center for Engineering Excellence confirmed that the operational (churn) test period for the

---

<sup>1</sup> Under separate contract, the Air Force Center for Engineering Excellence on-site quality assurance services were provided by Versar International Assistance Programs (Versar/VIAP) Iraq.

D-7 Clarifier Tank was only eight days because of a water shortage at the time. Consequently, run test observations by qualified contractor personnel were limited to only eight days versus the planned period of 30 days. Iraqi waste water treatment plant operators stated that they received only four days of operational training before the contractor left the site on 18 February 2006.

Government and contractor officials indicated that the D-7 sweep arm failure was in part or completely caused by the Iraqi waste water treatment plant operators. The contractor wrote that the sweep arm would have failed “...if the tank was not drained prior to restart.” Conversely, the Contracting Officer Representative of the Air Force Center for Engineering Excellence wrote: “It is believed that the Iraqi Army put the plant into operation after the turnover, but before adequate flow of liquids was available, thus causing the damage to the sweep arm.” Based on the differences between the two explanations, what actually led to the failure could not be determined. However, it is likely that the Iraqi waste water treatment plant operators were not sufficiently trained in large part because of the reduced testing period and the contractor’s quick departure from the site.

5. The project objective to plan and construct a waste water treatment plant compliant with World Health Organization 2000 Specifications was not fully realized at the time of our site visit. Specifically, the sweep scraper in the D-7 Clarifier Tank experienced catastrophic failure only 34 days after acceptance by government officials on 13 February 2006. As a result, the Al Kasik Waste Water Treatment Plant did not operate as planned between 19 March 2006 and 8 August 2006 when the assessment team completed the site visit. Until repaired, raw sewage in excess of the daily holding capacity of the facilities D-1 tank will continue to be pumped off the facility to the country side via a surface ditch creating a potential health hazard to local people and ground water supplies.

**Recommendations.** We recommend that the Director, Air Force Center for Environmental Excellence seek funding and implement a contract amendment to provide sufficient backup replacements and spare parts to ensure effective maintenance and sustained operation of the Al Kasik Waste Water Treatment Plant. As a point of reference, a sample list of backup replacements and spare parts is included in the body of this report. In addition, sufficient training should be provided to plant personnel to ensure that they can effectively operate the facility. The assessment team believed it would have been prudent to conduct 30 days of operational training on the clarifier tank and view the reported water shortage situation as a likely scenario of operations that plant operators would encounter.

We are making no additional recommendations because management representatives took or initiated appropriate corrective actions. During initial fieldwork, we confirmed that action to correct deficiencies with the sweep arm in the clarifier tank was underway. The Contracting Officer Representative of the Air Force Center for Engineering Excellence confirmed on 2 October 2006 that reconstruction of the G-3 pump pad structure was beginning in earnest as of 12 December 2006.

**Management Comments.** The Director, Air Force Center for Environmental Excellence concurred with the recommendation and issued an amendment to the contract to extend the period of performance to 31 Jan 07 for needed repairs to the facility. The Air Force Center for Environmental Excellence is also working an additional contract extension amendment to address replacement parts, personnel training, and maintenance issues.

**Evaluation of Management Comments.** Management comments fully addressed the issues raised in our conclusions and recommendation. These actions together with actions initiated prior to and during our assessment will resolve the issues we identified.

# Table of Contents

---

<b>Synopsis</b>	i
<b>Introduction</b>	
Objective of the Project Assessment	1
Pre-Site Assessment Background	1
Contract, Task Order, and Costs	1
Project Objective	2
Description of Facility (pre-construction)	2
Scope of Work of the Contract	2
<b>Site Assessment</b>	
Work Completed	4
Work in Progress and Pending	18
<b>Project Quality Management</b>	
Contractor Quality Control Program	18
Government's Quality Assurance Program	18
Quality Management	19
<b>Project Sustainability</b>	24
<b>Project Outcome</b>	26
<b>Conclusions</b>	26
<b>Recommendations</b>	28
<b>Management Comments</b>	29
<b>Evaluation of Management Comments</b>	29
<b>Appendixes</b>	
A. Scope and Methodology	30
B. Acronyms	31
C. Report Distribution	32
D. Project Assessment Team Members	34

# Introduction

---

## Objective of the Project Assessment

The objective of this project assessment was to provide real-time relief and reconstruction project information to interested parties in order to enable appropriate action, when warranted. Specifically, we determined whether:

1. Project components were adequately designed prior to construction or installation;
2. Construction or rehabilitation met the standards of the design;
3. The contractor's Quality Control (QC) and the U.S. Government's Quality Assurance (QA) programs were adequate;
4. Project sustainability was addressed; and
5. Project results were consistent with original objectives.

## Pre-Site Assessment Background

### Contract, Task Order, and Costs

Basic Contract FA8903-04-D-8676/Task Order (TO) 008, dated 22 January 2004, required the contractor to perform work in accordance with the Statement of Work (SOW) dated 9 January 2004. TO 008 was a Cost-Plus-Fixed-Fee (CPFF) contract with a Not To Exceed (NTE) value of approximately \$46.7 million. The basic contract, task order, and subsequent modifications were issued by the Air Force Material Command (AFMC) and administrated by Defense Contract Management Agency (DCMA).

Overall, eight modifications dated between 3 March 2004 and 31 December 2005 were applicable to the Task Order. Six modifications impacted the TO's value or field completion date or both. Modifications 1 and 3 were administrative. Most important with concern to the Waste Water Treatment Plant (WWTP) project was Modification 02, effective 15 April 2004, that increased the TO's value to approximately \$75.4 million and included the construction of a WWTP in the additional construction requirements and specifications described in a revised SOW dated 22 March 2004. Modification 2 established an initial field completion date of 1 July 2004. However, Modification 4, effective 21 July 2004, was written to extend the completion date for the WWTP project to 15 November 2004. Modification 5, effective 24 November 2004, extended the completion date to 28 February 2005 and increased the TO's value to approximately \$88.7 million. Modification 6, effective 7 July 2005, extended the field completion date to 31 October 2005 and increased the Task Order's final value to approximately \$92.2 million. In addition, Modification 6 included a revised SOW dated 30 June 2005. Modifications 7 and 8 increased the field completion dates to 31 December 2005 and 28 February 2006 respectively.

Construction of the WWTP was but one of a number of tasks required by the large scope of Task Order 008. Based on a review of the Quality Assurance reports, the WWTP was the last TO 008 project completed. The prime contractor for all TO 008 work was Shaw Environmental and Infrastructure, Inc (Shaw). Initially, Shaw subcontracted with an Iraqi firm to build the WWTP at Al Kasik Iraqi Army Base. However, this firm was replaced with a second firm in September 2005. The DD 1354, Transfer and Acceptance of Military Real Property, signed 13 February 2006, disclosed a cost of \$2.7 million for the WWTP at Al Kasik Army Base.



## **Project Objective**

The project objective was to plan and construct a waste water treatment plant compliant with World Health Organization 2000 specifications. The plant would be capable of handling peak and minimum flows with sufficient storage tanks upstream and downstream to satisfy system demand. The SOW required creation of a contractor work plan that included all pump curves, horsepower, and rpm; filter units flocculation tanks; hydro pneumatic tank ratings; valves; controls; the chlorination dosing system; tanks and fittings; and electrical controls and instrumentation.

## **Description of the Facility (pre-construction)**

The waste water treatment plant at Al Kasik Military Training Base was all new construction on a completely unencumbered site dedicated to plant construction.

## **Scope of Work of the Contract**

The scope of the project required the contractor to develop a work plan to select, provide, and install a waste water treatment plant. The SOW included the scope of the full range of construction and engineering activities to meet all customer requirements. The SOW included requirements for a work plan, methods, site conditions, and technologies. The major components of WWTP design included a clarifier tank, pump station, chlorination system, and back flush piping system.

### **Clarifier Tank**

Part of the waste water treatment process included a clarification stage. The tank used in this stage is called a clarifier. A clarifier is used to separate fecal solids and floating material from the homogenous liquid in the tank. In the clarifier, floating material and solids are separated to result in a uniform homogenous liquid. After separation, the liquid undergoes additional treatment.

Mechanical separation is used in the clarifier tank to help collect solids. An important part of mechanical separation is the “horizontal sweep arm” assembly. The “sweep arms” sweep solids into the tank base. From the tank base, the solids are pumped out of the clarifier tank for additional processing elsewhere in the WWTP.

Sweeping occurs when the sweep arm assembly rotates around the bottom of the tank. The diagram below (Diagram 1) shows the approved design for the sweep arm assembly. The sweep arm assembly consists of two horizontal metal sweep arms that are supported by a rotating central shaft. Cables attached to the center shaft support the outer ends of the arms. Sweeping takes place by rubber flaps or scrapers attached to the bottom of each arm. The rubber scrapers are positioned to move the solids on the tank floor as the assembly rotates around the tank.

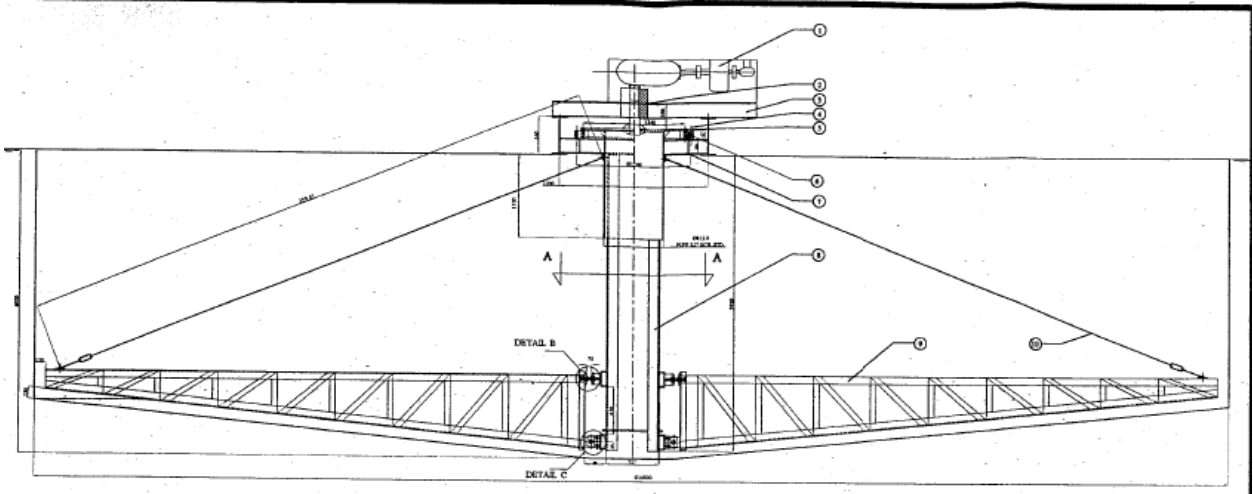

**Diagram 1. Diagram from contractor's submittal A-106 for clarifier torque calculations. The diagram does not show a vertical skimmer arm attached to the sweep arm.**

### **Pump Station**

The pump station consists of two sub grade (below ground) pumps and a small concrete protective structure for the pumps. Each pump rests on a concrete pad. The purpose of the concrete pad is to support each pump during operation and minimize vibration. The concrete pad's mass (heavy weight) helps to stabilize the pump during the pumping process.

### **Chlorination System**

In order to reduce the number of possible infectious organisms discharged from the WWTP, a disinfection step was designed to be a key part of the plant's system to produce acceptable discharge. Chlorination uses chemical chlorine for disinfection. As designed, the chlorination process at the Al Kasik WWTP consisted of introducing a chlorine compound into the water before discharge.

Chlorine is introduced to waste water in a tank called a contact tank. The amount of time that the waste water is exposed to the chlorine is called the contact time. The period of time and concentration of the chlorine compound are balanced to achieve acceptable reduction in microorganisms without exposing the water to excessive chlorine that could pass into the environment.

### **Back Flush System**

One of the final steps of the WWTP process is effluent filtration. The filtration step removes suspended solids as the effluent passes through the filter vessel and allows for final cleaning of the exiting water. When pressure filters are utilized in a filtration system, a back flush system is necessary to keep the filter clean. Back flushing is performed periodically to sustain effective filter operations.

## **Site Assessment**

The assessment team inspected the project on 1, 3, 7 and 9 August 2006. No construction was in progress because construction was completed and the facility was turned over to the Iraqi Government on 13 February 2006. The assessment team found that the clarifier

tank's sweep arm was not operating because it had failed on 19 March 2006. As a result, the facility was not operating or processing waste water. The observations of the assessment team are described in the following sections of this report: Clarifier Tank, Pump Station, Chlorination System, and Back Flush Pipe System.

## **Work Completed**

### **Clarifier Tank**

At the time of the assessment team's site visit, the D-7 Clarifier Tank was found to have been inoperable since 19 March 2006. Rather than resting in a level position, the horizontal sweep arm assembly (Diagram 1) was observed in an off-level position with one side lying on the floor of the tank while the opposite side was off the floor. In addition, the vertical main shaft of the clarifier tank's sweep arm assembly was off center and tilted. Lastly, the drive gearbox was broken beyond repair.

The complete failure of the clarifier tank likely occurred after a rapid series of negative events. Site Photo 1 shows the frayed segment of scraper arm support cable attached to the left front eyebolt of the arm. This suggested that the support cable attached to the front of the scraper arm broke, which caused the horizontal sweep arm assembly to drop and make contact with the floor. Site Photo 2 shows the presence of heavy surface and internal corrosion on the U-bolt assembly and the cable. The cable had a heavy degree of both surface and subsurface corrosion. Corrosion indicated that the cable material may not have been suitable for the application environment. Besides corrosion, overloading most likely contributed to cable failure. Specifically, the cable used may not have been strong enough for the load conditions encountered. The assessment team observed that the horizontal sweep arm assembly was built with a vertical skimmer structure. However, Diagram 1 does not show such an apparatus as part of the original design of the sweep arm assembly. In response to the assessment team's inquiry, the Contracting Officer Representative (COR) of the Air Force Center for Engineering Excellence (AFCEE) contacted the contractor. In an e-mail message dated 28 September 2006 sent to the AFCEE/COR, the contractor's program manager wrote:

*“My engineers are not aware of a revision for these arms. Looking at the previous photos and original drawings, the only conclusion we can draw is that (the Iraqi subcontractor)<sup>2</sup> picked up an old frame and fabricated a second to stiffen the frame. This could be the confusion. “*

In that the skimmer structure was not part of the original design, engineering load calculations were likely understated. Changes in the design, such as the addition of the skimmer structure, altered the boundary conditions for the original torque analysis of submittal A-106. The absence of a properly calculated design change to account for the addition of the skimmer structure during construction was likely the catalyst for the series of failures that rendered the clarifier tank inoperable.

---

<sup>2</sup> The name of the Iraqi contractor was excluded from the direct quote.



**Site Photo 1. Cable failure caused the clarifier arm assembly to drop to the bottom of the tank.**



**Site Photo 2. Support cable was frayed and corroded.**

The assessment team observed a scrape or gouge approximately 33 inches long in the wall of the clarifier tank (Site Photo 3) while a thin buildup of wall material remained on the leading edge of the scraper arm (Site Photo 4). No other similar scrapes were observed elsewhere in the clarifier tank. It would be reasonable to conclude that the supporting cable failure caused the scraper arm to fall and position the scraper arm against the tank wall while the arm was in motion and in contact with the floor. Accordingly, it is likely that subsequent gear box failure occurred quickly while the arm was in contact with the tank wall.



**Site Photo 3. Gouge mark approximately 33 inches long.**





**Site Photo 4. Sweep arm contact point.**

The main vertical supporting shaft of the rotating scraper arms was observed to be off center by over 2 1/8 inches. Site Photos 5 and 6, show the off center position of the main vertical shaft following the break down of the scraper arm assembly.



**Site Photo 5. Main shaft was positioned approximately 5 5/8 inches from the static frame.**



**Site Photo 6. Main shaft was positioned approximately 2 7/8 inches from the static frame.**

The off center vertical shaft was an indicator of an asymmetrical shaft load. The main shaft moved from center because of an unbalanced load caused by the added weight of the vertical skimmer structure attached during construction to one side of the horizontal scraper arm assembly. Conversely, the opposite side of the horizontal scraper arm assembly did not include a counterweight to offset the weight of the skimmer structure and unbalanced state of the horizontal sweep arm. In addition, an undetermined amount of additional drag force was created as the skimmer structure moved through the tank's liquid while the horizontal sweep arm assembly rotated. Accordingly, the overall load placed on the horizontal sweep arm assembly and drive gearbox likely increased substantially by the addition of the vertical skimmer structure. Simply put, the vertical skimmer structure attached during construction was big and heavy and caused the structure to be unbalanced. Diagram 2 illustrates the movement of the vertical shaft because of the unbalanced load on the horizontal sweep arm assembly. QA Photo 10 presented later in this report shows the skimmer assembly from the top while Site Photo 7 shows the skimmer from inside the tank.

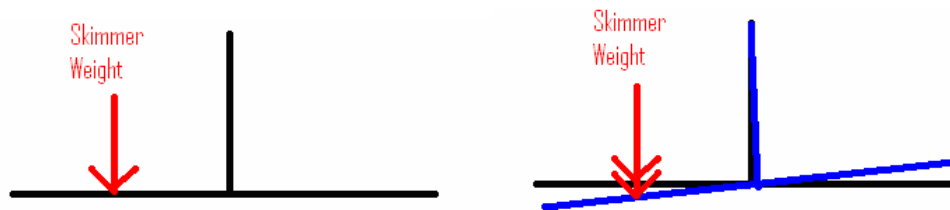

**Diagram 2. An unbalanced load on the horizontal arm assembly caused stress on the vertical shaft which forced the shaft to an off center position.**





**Site Photo 7. Skimmer structure viewed from inside the tank.**

Site Photos 8 and 9 show the difference in clearance distance between the floor and each side of the horizontal sweep arm assembly. Site Photo 8 shows the side that dropped when the cable failed. In Site Photo 8, the rubber scrapers were bent and in full contact with the floor. Conversely, Site Photo 9 shows the opposite side that did not experience cable failure. As such, the rubber scrapers shown in Site Photo 9 are not bent and hang freely above the floor by approximately 2 to 3 inches. If properly balanced, such rubber scrapers should gently touch the floor in order to sweep the floor during rotation of the horizontal sweep arm assembly.



**Site Photos 8. Rubber scrapers contact the floor on side that experienced cable failure.**





**Site Photo 9. The rubber scrapers hang freely on the side that did not experience cable failure.**

Immediately following the cable failure and subsequent contact between the dropped side of the horizontal sweep arm assembly and tank wall and floor, the clarifier gearbox, for all practical purposes, completely failed. The gearbox was lying in two pieces at the base of the clarifier tank. A fracture that bisected the gearbox housing ran the length of the cast metal casing. The oily coating and a distinct oil line observed indicated that the gearbox was operated with adequate lubrication before failure. Site Photo 10 shows the broken gear and fractured gearbox case. Based on the assessment team's observations of the failed cable, the off balanced horizontal sweep arm assembly, the off center vertical main shaft, the broken condition of the gearbox, discussions conducted with plant operators and Coalition Military Assistance Training Team/Regional Support Unit (CMATT/RSU) personnel, and a review of maintenance documentation (modest as it was), it is very unlikely that the gearbox failure was due to inadequate lubrication.



**Site Photo 10. "Chewed/sheared" gear teeth and a fractured gearbox case illustrate that abnormal force broke the gear box.**

Following the breakdown of the clarifier tank on 19 March 2006, the AFCEE Quality Assurance Representative (QAR) evaluated the situation at hand and submitted an Inspection Report dated 4 April 2006. The QAR's report included two specific points that should be noted:

- The construction of the sweep arm assembly in the D-7 Clarifier Tank did not include a fail-safe system such as a shear key, and
- The magnetic contactor overload relay that was installed did not function properly and shut down the motor.

Based on the assessment team's observation, a review of relevant documentation, and discussions conducted with WWTP operators and the AFCEE/COR, the assessment team concluded that the likely root cause of the break down of the clarifier tank was the addition of the vertical skimmer structure during construction without proper redesign to compensate for the added load placed on the supporting cable. After the cable broke, the sweep arm assembly dropped and made contact with the floor and wall. At that point in time, stresses quickly escalated and the gear box failed because a fail-safe system (shear key) was not included in the design and the installed magnetic contactor overload relay did not function properly and shut down the motor.

As a result of the failure of the clarifier, the WWTP was rendered inoperable and all waste water input was pumped directly off the site. Site Photo 23 shows raw sewage being pumped off the site.

### **Pump Station**

The G-03 pump station located beside the D-07 tank consisted of a below grade reinforced concrete pad with foundation walls. Placing the pumps below grade improved the efficiency of the pumps located on pads identified as G-03A and G-03B in Diagram 3. In addition, the diagram shows the relative location of the pump station in relation to the edge of the D-7 tank. In comparison to many of the concrete structures observed throughout the WWTP, the G-03 pump station was not a large structure. It measured approximately, 4.4 m (14.5 ft) by 2.7 m (9 ft) by 1.7 m (5.6 ft) deep. During the site visit, the assessment team observed significant fractures in the concrete structure along the base, walls, and corners of the G-03 pump station. A series of photos (Site Photos 11-18) illustrate what the assessment team observed while on site. Site Photos 11-16 were taken from inside the pump station while Site Photos 17 and 18 were taken from the outside.

**D-7 Edge**

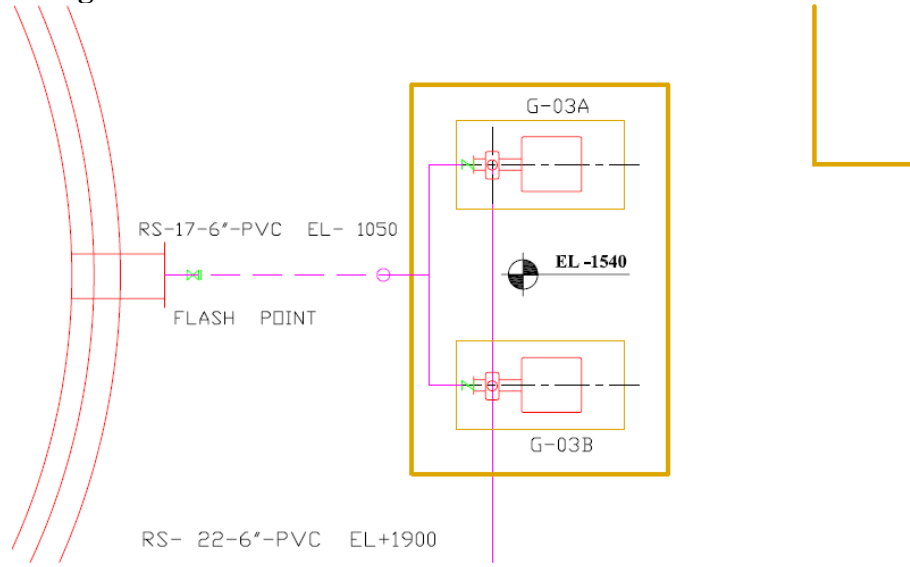

**Diagram 3. Pump Station G-03 from contractor's piping plan drawing.**

Site Photos 11 and 12 show that sizeable vertical cracks crept up the rear wall of the pump station.



**Site Photos 11 and 12. Vertical cracks were present in the inner rear wall of the pump station.**

Site Photos 13 and 14 show the horizontal fracturing that occurred near the base of the structure and at a point approximately half way up the wall. The horizontal cracks were generally parallel to each other. Site Photos 15 and 16 show very similar horizontal cracks that wrapped around the opposite corners in the rear wall of the pump station.



**Site Photos 13 and 14. Horizontal wall cracks along floor and middle of the wall.**



**Site Photos 15 and 16. Horizontal cracks near the floor at opposite corners of the G-03 building.**

Site Photos 17 and 18 illustrate that the cracking extended all the way from the bottom to the top and from the inside to the outside of the structure's rear wall.



**Site Photos 17 and 18. Vertical cracks wound their way to the outer corners of the rear wall.**

During a review of design and Quality Control documentation, the assessment team found contractor's submittal A-41, G-03 pump pad details, (Diagram 4) with comments that specified the BRC #63 should be replaced with steel bar reinforcement.



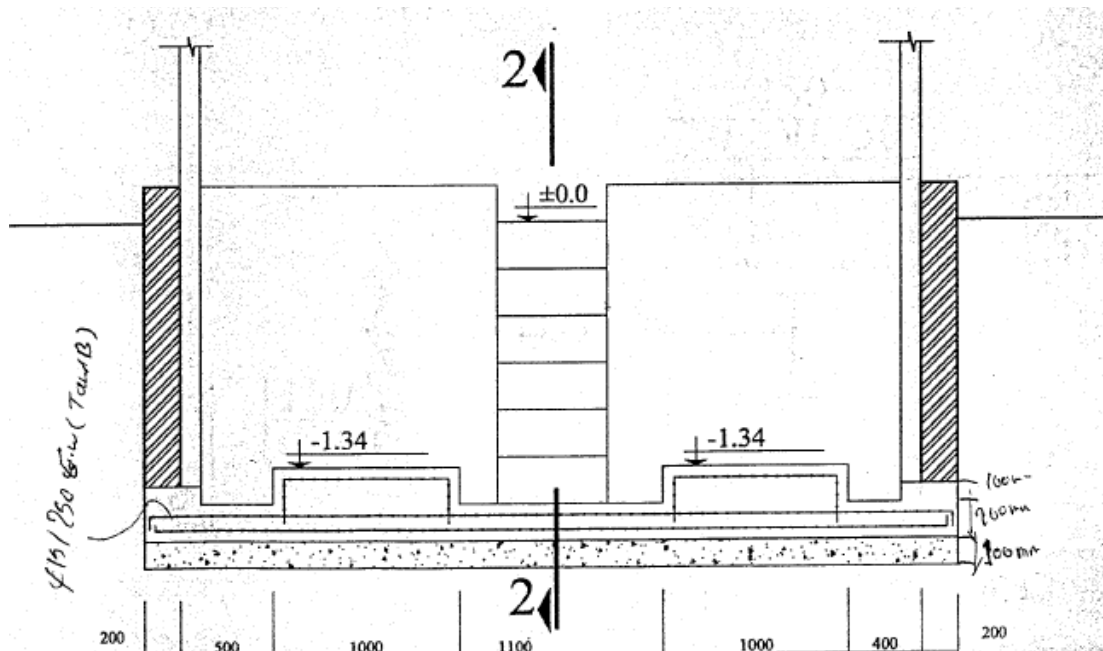

Diagram 4. Cross section of G-03 building from the contractor's A-41 submittal.

Based on the assessment team's observations, a review of design and QC documentation, and discussions conducted with the CMATT/RSU Engineer and the AFCEE/COR, the number of cracks of such magnitude indicated that abnormal stress was distributed across the rear concrete wall of the structure. In addition, such cracks were likely caused by, either/or a combination of, insufficient steel reinforcement of the concrete or inadequate soil compaction. The horizontal cracks that ran from corner to corner of the rear wall indicated that settling of the base slab was very likely. Inadequate soil compaction could cause such settling. Even if properly reinforced, much less if not sufficiently reinforced, the concrete wall would have been prone to cracking if constructed on soil that was not sufficiently compacted.

During fieldwork discussions, the AFCEE/COR agreed that the pump station should be reconstructed to prevent continued degradation of the pump station and as a hedge against future failure in the G-03 pump station.

### Chlorination System

The Al Kasik Waste Water Treatment Plant employed a chlorine disinfection system to kill microorganisms. Disinfection, which preceded filtration, was designed as one of the final processes to reduce the number of possible infectious microorganisms discharged from the WWTP.

The introduction of a chlorine compound was the method employed at the facility. The chlorination system installed consisted of a supply tank for the chlorination agent, a pump, a chlorine injection system, and a contact tank to introduce the chlorine compound into the effluent. According to Environmental Protection Agency (EPA) 832-F-99-034 Combined Sewer Overflow Technology Fact Sheet on Chlorine Disinfection, common forms of chlorine administration are chlorine gas, sodium hypochlorite (chemical compound NaOCL), and calcium hypochlorite.

The chlorination administration system chosen for the Al Kasik WWTP consisted of a liquid chlorine chlorination agent, sodium hypochlorite (NaOCL). For all practical

purposes, the chlorine agent used at the WWTP was nothing more than concentrated household bleach. A holding tank was required to store the liquid NaOCL; a pump, an injection system, and a contact tank were used to apply the agent to the effluent. Site Photo 19 shows the chlorine agent holding tank.



**Site Photos 19. Chlorination system included a holding tank for Sodium Hypochlorite (NaOCL).**

During the assessment team's visit, it was noted that the contact tank contained dried, suspended solids that were visible on the floor of the tank. Site Photo 20 shows the solids observed. While suspended solids are a normal part of unfiltered effluent processed in any waste water treatment plant, the unfiltered solution is normally not chlorinated because suspended solids interfere with the efficiency of a chlorination process. In the case at hand, chlorine was added before the effluent had effectively passed through the pressure filters, which would have removed suspended solids. The design, as built, exposed the suspended solids to chlorine in the contact tank.

Based on information from the EPA Chlorine Disinfection fact sheet, high levels of suspended solids entrap residual bacteria and interfere with the efficiency of waster water disinfection. In addition, the Standard Handbook for Civil Engineers cites that "The last step in secondary treatment of wastewater is disinfection of the effluent to kill pathogenic (disease-causing) bacteria and viruses." In contrast to the pre-filter system built at the Al Kasik WWTP, a post-filter contact tank system might have been a more efficient system to use.



**Site Photos 20. Prefilter chlorination tank floor was covered with solids.**

According to the EPA Chlorine Disinfection fact sheet, 85 degrees Fahrenheit is the maximum (not to exceed) temperature in which liquid NaOCL should be stored. At the time of the assessment team's visit, temperatures were well above 100 degrees Fahrenheit. Obviously, the temperatures routinely experienced in Iraq during the hot season exceed the EPA 85 degree Fahrenheit threshold.

NaOCL can either be purchased as a prepackaged mix or generated continuously on site with a NaOCL generator. The Al Kasik WWTP utilized a NaOCL storage tank system that would have to be re-supplied as inventories were consumed. Based on discussions with WWTP operators, NaOCL agent could not be purchased from local sources.

In summary, the chlorination system installed was designed to chlorinate effluent at the pre-filter stage containing suspended solids. Additionally, re-supply of the current chlorination material (NaOCL) was difficult. The storage environment for the plant's NaOCL tank was subject to temperatures outside the upper storage limit for NaOCL. Considering the design, storage, and logistics discussed in this report, the design as built might not have been the best choice because the pre-filter disinfection process would not be as effective as a post-filter design.

### **Back Flush Pipe**

The final step was filtering the chlorinated effluent through a pressure filter. The pressure filtration process would remove most of the remaining solids.

The plant's pressure filter system design utilized two sets of inlet lines. One set of inlet lines supplied the filters with effluent while the other set of inlet lines were used to back flush the pressure filters as part of normal maintenance/operation to ensure that filters were sufficiently clean. The two sets of inlet lines are shown in Site Photo 21.

Effluent Supply Side with NaOCL Tank.

Back Flush Side Showing Missing Nipple.



**Site Photo 21. Effluent supply and back flush inlet piping systems.**

The assessment team observed that a pipe nipple on the back flush side of the inlet system was missing. A backup or spare nipple was not a required element of the Task Order and the WWTP operators claimed that the non-standard sized nipple could not be purchased locally. As a result, back flush operations could not be performed. Site Photo 22 shows the back flush inlet line was missing the relatively minor piece.

Missing Nipple



**Site Photo 22. Missing nipple meant that back flushing could not be performed.**

In that the WWTP was designed as a linear system, any disruption along the path of waste water flow from beginning to end would result in failure of plant operations. Stated otherwise, when a single part of the system fails, the entire system fails. In the example of the back flush nipple, a simple part precluded sufficient back flushing operations needed to keep the important pressure filters clean.



## **Work in Progress and Pending**

At the time of the assessment team's site visits, no work was in progress. However, the team confirmed that government officials had initiated corrective action to correct the construction and design deficiencies cited in this report. As of 2 October 2006, repair work activities to correct clarifier tank and G-03 pump station deficiencies were pending. AFCEE/COR confirmed on 14 December 2006 that repair work to the facility had started "in earnest" on 12 December 2006.

## **Project Quality Management**

### **Contractor's Quality Control Program**

The TO's SOW required the contractor to prepare a site specific Quality Program Plan (QPP) for each task order for AFCEE review and approval. The QPP was to include a Health and Safety plan (HSP) and Construction Quality plan (CQP). In February 2004, the contractor prepared a site specific QPP that included a comprehensive HSP and CQP.

Based on the CQP, the contractor was required to function as an integral team member in support of the AFCEE mission. Requirements included efficient management of this TO including accurate, on-time submittal of contract deliverables and timely identification and solution of impediments to successful project execution.

The CQP includes the following sections:

- Personnel responsibility and authority
- Qualifications of QC personnel
- List of definable features for work
- Procedures for scheduling and managing submittals and requests for information
- Inspection schedule
- Implementation of three phase control system
- QC performance activities
- Performance and report formatting of QC testing
- Method for tracking construction deficiencies
- Project completion turn-over and acceptance procedures
- Outline for final report

The contractor was required to present a completed Defense Department (DD) Form 1354, Transfer and Acceptance of Real Property, in order to transfer real property after the final inspection was conducted. A one-year construction warranty was included in accordance with Federal Acquisition Regulation (FAR) 52.246.21.

### **Government's Quality Assurance Program**

Quality Assurance (QA) is the system by which the government fulfills its responsibility to ensure the contractor Quality Control system is functional and effective. Project and Contracting Office Standard Operating Procedure CN-100, Construction Contractor QC/QA Inspection and Reporting, specifies requirements for an adequate and effective Government QA program while CN-102, Contractor Quality Control/Quality Assurance Construction Deficiency Tracking, provides more specific guidance pertaining to the mechanics of a QC/QA deficiency tracking system and relevant Quality Assurance Representative (QAR) responsibilities.

On-site QA personnel should monitor a contractor's processes in order to track construction deficiencies to ensure acceptable corrective action is taken and to maintain an audit trail and also to ensure that new work is not combined with unacceptable work. Based on the inspector's review of all QA reports submitted between 2 June 2005 and 15 February 2006, quality assurance activities were sufficiently documented on the standardized AFCEE Quality Assurance Reports. Specifically, the reports were reasonably well written, adequately descriptive, sufficiently complete, and almost always supported by relevant photos. In addition, QA reports included a Discrepancies and Non-Compliance Items section used to monitor and track timely correction of construction deficiencies. The AFCEE/COR considered the QA reports reliable and an effective project monitoring tool.

### **Quality Management**

Quality Management (QM) is defined as the combination of all QC and QA activities instituted to achieve the quality established by the contract requirements. Accordingly, obtaining quality construction is a combined responsibility of the construction contractor and the government. Their mutual goal must be a quality product conforming to contract requirements. A cooperative and professional working relationship should be established in order to realize the common goal of effective quality management.

The assessment team determined that Quality Management (QM) practices were adequate and generally effective. Accordingly, construction deficiencies referred to in this report were not caused by a pattern of lax or ineffective QM practices or personnel. Based on a discussion with QA Representatives assigned to the WWTP project since June 2004, working relationships were good and QA personnel had no on-site difficulties with the contractor's engineering and Quality Control personnel as they supervised construction work. In addition, the QA Representative confirmed that daily QC reports were sufficiently detailed and generally timely.

The following photos were copied directly from QA reports. QA Photo 1 shows a pressure test in progress while QA Photo 2 shows a hydro-test in progress<sup>3</sup>. Some photos included in QA reports documented that various inspections were performed. For example, QA Photo 3 shows the contractor's QC manager inspecting pipe flanges to ensure conformity with requirements and QA Photo 4 shows that concrete work was subjected to a real-time slump test while cube samples were taken for subsequent laboratory strength testing. QA Photos 5 through 8 show various contractor activity or techniques used to construct the WWTP. QA Photos 5 and 6 show that the contractor constructed good forms in both flatwork and vertical applications. QA Photo 7 documents that concrete work included a process to vibrate the fresh concrete before finish work started. QA Photo 8 demonstrates the contractor's technique to cure concrete. Such photos provided off-site managers with meaningful information and effectively supplement daily report narratives.

---

<sup>3</sup> Pressure tests are performed by applying air pressure while hydro-tests are performed by applying water under pressure to an isolated section of piping the generally includes valves and fitting.



**QA Photo 1. Pressure testing a pipeline (from QA Report 4 Oct 2005).**



**QA Photo 2. Hydro-testing a pipe line between tanks (from QA Report 23 Dec 2005).**



**QA Photo 3. QC Manager inspected and rejected pipe flanges (from QA Report 11 Sep 2005).**



**QA Photo 4. Slump test and 2 cube samples taken for laboratory concrete strength testing (from QA report 26 Oct 2005).**



**QA Photo 5. Flatwork form with clear / sufficiently sized lumber and proper brace placement (from QA Report 14 Dec 2005).**



**QA Photo 6. Good form techniques were used to build a sub-grade foundation with supervisors on site (from QA Report 11 Oct 2005).**





**QA Photo 7. Supervisor watched worker consolidate concrete with a hand held mechanical vibrator<sup>4</sup> (from QA Report 26 Oct 2005).**



**QA Photo 8. Concrete covered with burlap to prevent too rapid drying and decreased strength (from QA Report 3 Oct 2005).**

---

<sup>4</sup> Proper mechanical vibration of fresh concrete optimizes strength, durability, and appearance by eliminating trapped air and voids while fully encasing rebar.

## Project Sustainability

While not addressed in contract requirements, a variety of spares and parts were needed to effectively maintain and sustain plant operations. During the site visit, the assessment team observed several inoperative components of the WWTP because of unavailable commonplace spares or parts. For example, a coupling between the drive motor and agitator pump in tank D-01 needed to be changed out in order to adequately agitate the D-01 tank. In addition, the back flush system was not operational due to a broken pipe nipple. Based on discussions with plant operators, Sodium Hypochlorite, needed to operate the chlorination system as designed and installed, was not available from local suppliers.

The assessment team conducted discussions with the Iraqi plant operators and the CMATT/RSU Engineer in order to create a sample list of spares or parts that could be used to maintain the plant and improve chances for sustained operations. The following sample list was developed:

- A supply of Sodium Hypochlorite
- Couplings for the various drive motor applications
- Plastic pipe stock, fittings, and nipples
- Spare gear box for clarifier tank
- Spare water height sensors for various applications on site
- Polyvinyl Chloride (PVC) high pressure pipe stock, elbows, tee sections and valves (12,8,6,4, & 2")
- Duct tape and PVC glue
- An inventory of replacement motors and pumps for each application on site
- An extra of each electric circuit breaker
- General inventory of light bulbs

In addition to design and construction issues raised elsewhere in this report, insufficient operational/run testing and plant operator training before turn-over to the Iraqi Army could have been contributing factors to the break down of the D-7 Clarifier Tank on 19 March 2006. Based on the assessment team's review of QA reports, QA Photo 9 showed that D-7 Clarifier Tank was empty on 31 January 2006. QA Photo 10 from the 5 February 2006 QA report was the first photo that showed the clarifier tank in a full state. Coincidentally, the 5 February 2006 QA report was the first to include QAR comments related to operational testing of the D-7 tank pump(s). Based on the review of the QA reports between 31 January and 13 February 2006, the assessment team concluded that operational testing of the D-7 Clarifier Tank likely started on 5 February 2006, 8 days before the government's representative signed the DD Form 1354, Transfer and Acceptance of Military Real Property, and accepted the WWTP on 13 February 2006. On 3 October 2006, the AFCEE/COR confirmed that government officials and the contractor jointly agreed to cut short the operational (churn) test period for the clarifier tank and sweep arm because of a water shortage at the time. Consequently, operational/run test observations by qualified contractor personnel to evaluate the clarifier's performance were limited to only 8 days vs. 30 days as planned.

Iraqi WWTP operators said that contractor personnel provided only four days operational/run training before turn-over. In the absence of documented information to the contrary, the claim by WWTP operators seems plausible. Based on emails reviewed by the assessment team, government, and the contractor officials indicated that the sweep

arm failure on 19 March 2006 was in part or completely caused by the Iraqi WWTP operators. In an e-mail response to our inquiry, the contractor wrote that the sweep arm would have failed *“if the tank was not drained prior to restart.”* Conversely, the AFCEE/COR wrote: *“It is believed that the Iraqi Army put the plant into operation after the turnover, but before adequate flow of liquids was available, thus causing the damage to the sweep arm.”* Based on the differences between the two explanations, what actually led to the failure could not be determined. However, it is likely that the Iraqi WWTP operators were not sufficiently trained in large part because of the reduced testing period and the contractor’s quick departure on 18 February 2006.



**QA Photo 9. Empty clarifier tank (QA Photo 9 from QA Report dated 31 Jan 2006)**

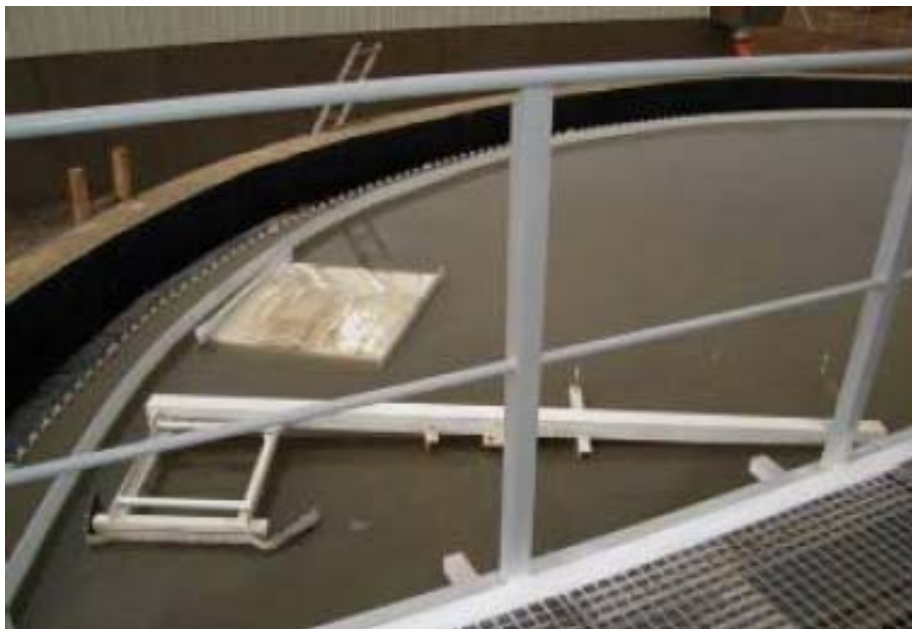

**QA Photo 10. Full clarifier tank (from QA Report dated 5 Feb 2006)**



## Project Outcome

The project objective to plan and construct a waste water treatment plant compliant with World Health Organization 2000 Specifications for waste water treatment capable of handling peak and minimum flows with sufficient storage tanks upstream and downstream to satisfy system demand was not fully realized. Specifically, the sweep scraper assembly in the D-7 Clarifier Tank experienced catastrophic failure only 34 days after acceptance by government officials on 13 February 2006. As a result, the WWTP has not operated as planned from 19 March 2006, when the D-7 scraper arm broke down, to 8 August 2006 when the assessment team conducted the site visit. Until repaired, raw sewage in excess of the daily holding capacity of the facilities D-1 tank will continue to be pumped off the facility (Site Photo 23) to the country side via a surface ditch creating a potential health hazard to local people and ground water supplies.



Site Photo 23. Raw sewage pumped off site via surface ditch.

## Conclusions

We reached the following conclusions for our assessment objectives:

1. Determine whether project components were adequately designed prior to construction or installation.

In general, project components were adequately designed prior to construction of the Al Kasik Military Training Base Waste Water Treatment Plant. However, the assessment team noted that the chlorination system disinfected at the pre-filter stage, where prevalent suspended solids reduced disinfection efficiency. As an alternative, a post filter stage chlorination process would have been more effective because suspended solids would have been significantly reduced before the chlorination process. In addition, the current chlorination solution (the chemical compound

NaOCL) may not have been compatible for storage in the temperature extremes of the local environment.

2. Determine whether construction met the standards of the design.

Construction at the Waste Water Treatment Plant appeared to meet design standards, with two exceptions. First, the clarifier tank's sweep arm assembly was not built in accordance with the approved design documentation made available to and reviewed by the assessment team. This failure to construct the tank sweep arm to the design may have been the primary factor or a significant contributing factor at the least that led to a complete failure of the clarifier tank on 19 March 2006. As a result, the Waste Water Treatment Plant was operationally ineffective from March 19, 2006 to the date of the site inspection.

Second, the assessment team found that the G-3 pump station experienced a significant amount of structural fracturing and damage. Based on discussions with government officials and the assessment team's on-site observations of the fractures, the assessment team believed that inadequate soil compaction before the concrete was cast was the most likely reason for fracturing. However, it is also possible that the contractor did not tie reinforcement steel at the corner of the G-3 foundation as required before the concrete was cast. Improper steel reinforcement at the corners could have contributed to the severe fracturing. In any case, the physical failure of the concrete could result in failure of the G-3 pump station piping and pump.

3. Determine whether the contractor's Quality Control and the Government Quality Assurance programs were adequate.

The contractor's Quality Control and the U. S. Government's Quality Assurance programs were found to be generally effective. The contractor submitted an adequate Quality Control plan before construction was scheduled to start on 1 June 2004 that addressed key elements needed for effective quality control. For example, the Quality Control plan defined the qualifications, responsibilities, and authority of contractor and subcontractor managers. In addition, the Quality Control plan disclosed definable features of work in adequate detail. Quality Assurance activities were sufficiently documented on standardized Air Force Center for Engineering Excellence Quality Assurance Reports that were reasonably well written, descriptive, complete, and almost always supported by relevant photos. In addition, Quality Assurance reports included a "Discrepancies and Non-Compliance Items" section to monitor and track timely correction of construction deficiencies. As a result, Quality Management practices were effective and any construction deficiencies referred to in this report were not caused by generally lax or ineffective quality management practices or personnel.

4. Determine if project sustainability was addressed.

Not all aspects of project sustainability were adequately addressed in the contract. For example, the contractor was not required to provide a sufficient inventory of backup replacements and spare parts to effectively maintain Al Kasik Waste Water Treatment Plant components in order to sustain operations. During the on-site visit, the assessment team observed several instances where components of the WWTP were inoperative because there was not an inventory of backup replacements or spare parts. There also was an array of common components without an inventory of backup replacements or spare parts necessary to facilitate real-time component change out or repair and routine plant maintenance. This condition occurred because Task Order requirements related to project sustainability were too vague. As a result, the failure of

a common component did and could continue to lead to significant disruption in WWTP operations and effectiveness.

Aside from design and construction issues raised elsewhere in this report, insufficient operational/run testing and ineffective plant operator training before turn-over were likely contributing factors to the failure of the clarifier tank. The assessment team verified that the operational (churn) test period for the D-7 Clarifier Tank was only eight days because of a water shortage at the time. Consequently, run test observations by qualified contractor personnel were limited to only 8 days versus the planned period of 30 days. In addition, Iraqi WWTP operators claimed they received only four days operational training before the contractor left the site on 18 February 2006.

Based on emails reviewed by the assessment team, government and contractor officials implied/alleged that D-7 sweep arm failure was in part or completely caused by the Iraqi WWTP operators. The contractor wrote that the sweep arm would have failed *“if the tank was not drained prior to restart.”* Conversely, the AFCEE/COR wrote: *“It is believed that the Iraqi Army put the plant into operation after the turnover, but before adequate flow of liquids was available, thus causing the damage to the sweep arm.”* Based on the differences between the two explanations, what actually led to the failure could not be determined. However, it is likely that the Iraqi WWTP operators were not sufficiently trained in large part because of the reduced testing period and the contractor’s quick departure from the site.

5. Determine whether project results were consistent with original objectives.

The project objective to plan and construct a waste water treatment plant compliant with World Health Organization 2000 Specifications was not fully realized at the time of our site visit. Specifically, the sweep scraper in the D-7 Clarifier Tank experienced catastrophic failure only 34 days after acceptance by government officials on 13 February 2006. As a result, the Waste Water Treatment Plant did not operate as planned between 19 March 2006 and 8 August 2006 when the assessment team completed the site visit. Until repaired, raw sewage in excess of the daily holding capacity of the facilities D-1 tank will continue to be pumped off the facility to the country side via a surface ditch creating a potential health hazard to local people and ground water supplies.

## **Recommendations**

We recommend the Director, Air Force Center for Environmental Excellence seek funding and implement a contract amendment to provide sufficient backup replacements and spare parts to ensure effective maintenance and sustained operation of the Al Kasik Waste Water Treatment Plant. As a point of reference, a sample list of backup replacements and spare parts is included in the body of this report. In addition, sufficient training should be provided to plant personnel to ensure that they can effectively operate the facility. The assessment team believed it would have been prudent to conduct 30 days of operational training on the clarifier tank and view the reported water shortage situation as a likely scenario of operations that plant operators would encounter.

We are making no additional recommendations because management representatives took or initiated appropriate corrective actions. During initial fieldwork, we confirmed that action to correct deficiencies with the sweep arm in the clarifier tank was underway. The Contracting Officer Representative of the Air Force Center for Engineering Excellence

confirmed on 2 October 2006 that reconstruction of the G-3 pump pad structure was beginning in earnest as of 12 December 2006.

## **Management Comments**

The Director, Air Force Center for Environmental Excellence concurred with the recommendation and issued an amendment to the contract to extend the period of performance to 31 Jan 07 for needed repairs to the facility. The Air Force Center for Environmental Excellence is also working an additional contract extension amendment to address replacement parts, personnel training and maintenance issues.

## **Evaluation of Management Comments**

Management comments fully addressed the issues raised in our conclusions and recommendation. These actions together with actions initiated prior to and during our assessment will resolve the issues we identified.

## **Appendix A. Scope and Methodology**

---

We performed this project assessment from August through December 2006 in accordance with the Quality Standards for Inspections issued by the President's Council on Integrity and Efficiency. The assessment team included an engineer/inspector and an auditor/inspector.

In performing this Project Assessment, we:

- Reviewed contract documentation to include Basic Contract FA8903-04-D-8676, Task Order FA8903-04-D-8676 / OO8, and TO Modifications 1 through 8;
- Reviewed requirements and specifications contained within the Statement of Work and contractor design submittals. In addition, selected documentation supporting the Contractor's Quality Control and the Government's Quality Assurance programs were reviewed;
- Interviewed or discussed the project with the AFCEE/COR, a QAR, two Iraqi Waste Water Treatment Plant operators, CMATT/RSU personnel stationed at Al Kasik, and personnel in the Engineering Section of the Multinational Security Transition Command – Iraq stationed in the International Zone, Baghdad; and
- Conducted on-site assessments of the WWTP on 1, 3, 7, and 9 August 2006.

## Appendix B. Acronyms

---

AFCEE	Air Force Center for Environmental Excellence
AFMC	Air Force Materiel Command
COR	Contracting Officer Representative
CPFF	Cost Plus Fixed Fee
CMATT	Coalition Military Assistance Training Team
CQP	Construction Quality Plan
DCMA	Defense Contract Management Agency
EPA	Environmental Protection Agency
FAR	Federal Acquisition Regulations
HSP	Health and Safety Plan
m	Meter
NaOCL	Sodium hypochlorite (chemical compound)
NTE	Not To Exceed
PVC	Polyvinyl Chloride
QA	Quality Assurance
QAR	Quality Assurance Representative
QC	Quality Control
QM	Quality Management
QPP	Quality Program Plan
RSU	Regional Support Unit
SOW	Statement of Work
TO	Task Order
WWTP	Waste Water Treatment Plant

## **Appendix C. Report Distribution**

---

### **Department of State**

Secretary of State

Senior Advisor to the Secretary and Coordinator for Iraq

U.S. Ambassador to Iraq

Director, Iraq Reconstruction Management Office

Inspector General, Department of State

### **Department of Defense**

Secretary of Defense

Deputy Secretary of Defense

Director, Defense Reconstruction Support Office

Under Secretary of Defense (Comptroller)/Chief Financial Officer

Deputy Chief Financial Officer

Deputy Comptroller (Program/Budget)

Inspector General, Department of Defense

### **Department of the Army**

Assistant Secretary of the Army for Acquisition, Logistics, and Technology

Principal Deputy to the Assistant Secretary of the Army for Acquisition,  
Logistics, and Technology

Deputy Assistant Secretary of the Army (Policy and Procurement)

Assistant Secretary of the Army for Financial Management and Comptroller

Chief of Engineers and Commander, U.S. Army Corps of Engineers

Commanding General, Gulf Region Division

Auditor General of the Army

### **Department of the Air Force**

Director, Air Force Center for Environmental Excellence

### **U.S. Central Command**

Commanding General, Multi-National Force – Iraq

Commanding General, Joint Contracting Command – Iraq/Afghanistan

Commanding General, Multi-National Corps – Iraq

Commanding General, Multi-National Security Transition Command – Iraq

Commander, Joint Area Support Group – Central

### **Other Defense Organizations**

Director, Defense Contract Audit Agency

## **Other Federal Government Organizations**

Director, Office of Management and Budget  
Comptroller General of the United States  
Inspector General, Department of the Treasury  
Inspector General, Department of Commerce  
Inspector General, Health and Human Services  
Inspector General, U.S. Agency for International Development  
Mission Director – Iraq, U.S. Agency for International Development

## **Congressional Committees and Subcommittees, Chairman and Ranking Minority Member**

### **U.S. Senate**

Senate Committee on Appropriations  
    Subcommittee on Defense  
    Subcommittee on State, Foreign Operations and Related Programs  
Senate Committee on Armed Services  
Senate Committee on Foreign Relations  
    Subcommittee on International Operations and Terrorism  
    Subcommittee on Near Eastern and South Asian Affairs  
Senate Committee on Homeland Security and Governmental Affairs  
    Subcommittee on Federal Financial Management, Government Information and International Security  
    Subcommittee on Oversight of Government Management, the Federal Workforce, and the District of Columbia

### **U.S. House of Representatives**

House Committee on Appropriations  
    Subcommittee on Defense  
    Subcommittee on Foreign Operations, Export Financing and Related Programs  
    Subcommittee on Science, State, Justice and Commerce and Related Agencies  
House Committee on Armed Services  
House Committee on Government Reform  
    Subcommittee on Management, Finance and Accountability  
    Subcommittee on National Security, Emerging Threats and International Relations  
House Committee on International Relations  
    Subcommittee on Middle East and Central Asia



## **Appendix D. Project Assessment Team Members**

The Office of the Assistant Inspector General for Inspections, Office of the Special Inspector General for Iraq Reconstruction, prepared this report. The principal staff members who contributed to the report were:

William Tweedy

Lloyd Wilson