



Assessing the Multiple Benefits of Clean Energy

A RESOURCE FOR STATES



ACKNOWLEDGEMENTS

This document, *Assessing the Multiple Benefits of Clean Energy: A Resource for States*, was developed by the Climate Protection Partnerships Division in EPA's Office of Atmospheric Programs. Denise Mulholland managed the overall development of the *Resource*. Julie Rosenberg and Kathleen Hogan (now with U.S. DOE) provided content and editorial support for the entire document.

The U.S. Environmental Protection Agency (EPA) would like to acknowledge the many other EPA employees and consultants whose efforts helped to bring this extensive product to fruition.

The following EPA contributors provided significant assistance through their technical and editorial review of chapters within the *Resource*:

Jeffrey Brown, Ben DeAngelo, Andrea Denny, Art Diem, Nikolaas Dietsch, Steve Dunn (now with U.S. DOE), Neal Fann, Caterina Hatcher, Kathleen Hogan (now with U.S. DOE), Bryan Hubbell, Dan Loughlin, Katrina Pielli, Julie Rosenberg, and Eric Smith.

A multi-disciplinary team of energy and environmental consultants provided research and editorial support, as well as technical review of chapters within this *Resource*. They include: Stratus Consulting (Heidi Ries, Joanna Pratt, James Lester, Joe Donahue and Leland Deck); Synapse Energy Economics (Alice Napoleon, Bill Steinhurst, Max Chang, Kenji Takahashi and Robert Fagan); Summit Blue (Kevin Cooney and Mike Bammel); Energy and Environmental Economics, Inc. (Snuler Price); Demand Research LLC (Marvin Horowitz); Abt Associates, Inc. (Mike Fisher, Dan Basoli); and ICF International (Joshua Smith, Juanita Haydel, Brad Hurley, Mark Lee, Jay Haney, Bansari Saha and Karl Hausker).

For more information, please contact:

Denise Mulholland

U.S. Environmental Protection Agency
State and Local Climate and Energy Programs

TEL: (202) 343-9274

EMAIL: mulholland.denise@epa.gov

ASSESSING THE MULTIPLE BENEFITS OF CLEAN ENERGY:
A RESOURCE FOR STATES

Table of Contents

PREFACE	V
CHAPTER ONE	1
Introduction	
CHAPTER ONE CONTENTS	
1.1 What are the Multiple Benefits of Clean Energy?	3
1.1.1 Energy Savings and Renewable Energy Generation: The Foundation for Benefits	3
1.1.2 Energy System Benefits	3
1.1.3 Environmental and Health Benefits	5
1.1.4 Economic Benefits	6
1.2 Why Assess the Multiple Benefits of Clean Energy?	8
1.2.1 Demonstrating the Multiple Benefits of Clean Energy	8
1.2.2 Designing or Selecting Options that Achieve Greater or Broader Benefits	8
1.2.3 Identifying Opportunities to Use Clean Energy in Other Planning Processes	9
1.2.4 Building Support for Clean Energy Policies and Program	11
1.3 How do States Assess the Multiple Benefits of Clean Energy?	11
References	14
CHAPTER TWO	19
Assessing the Potential Energy Impacts of Clean Energy Initiatives	
CHAPTER TWO CONTENTS	
2.1 How Do Clean Energy Policies Affect Energy?	20
2.2 How Can States Estimate the Potential Direct Energy Impacts of Clean Energy Policies?	21
2.2.1 STEP 1: Develop a Business-As-Usual Energy Forecast	22
2.2.2 STEP 2: Quantify Implications of Targets and Goals	33
2.2.3 STEP 3: Estimate Potential Direct Energy Impacts	35
2.2.4 STEP 4: Create an Alternative Policy Forecast	44
2.3 Case Studies	45
2.3.1 Texas Building Code	45
2.3.2 Vermont - Energy and Energy Savings Forecasting	47

Information Resources	49
References	50
CHAPTER THREE.....	51
Assessing the Electric System Benefits of Clean Energy	
CHAPTER THREE CONTENTS	
3.1 How Clean Energy Can Achieve Electric System Benefits.....	53
3.1.1 The Structure of the U.S. Energy System	53
3.1.2 Primary and Secondary Benefits of Clean Energy.....	54
3.2 How States Can Estimate the Electric System Benefits of Clean Energy.....	56
3.2.1 How to Estimate the Primary Electric System Benefits of Clean Energy Resources	61
3.2.2 How to Estimate the Secondary Electric System Benefits of Clean Energy Resources.....	77
3.3 Case Studies.....	83
3.3.1 California Utilities’ Energy Efficiency Programs	83
3.3.2 Energy Efficiency and Distributed Generation in Massachusetts	85
Information Resources	86
References	89
CHAPTER FOUR.....	93
Assessing the Air Pollution, Greenhouse Gas, Air Quality, and Health Benefits of Clean Energy Initiatives	
CHAPTER FOUR CONTENTS	
4.1 How Clean Energy Initiatives Result in Air and Health Benefits.....	95
4.2 How States Estimate the GHG, Air, and Health Benefits of Clean Energy	98
4.2.1 Step 1: Develop and Project a Baseline Emissions Profile	98
4.2.2 Step 2: Quantify Air and GHG Emission Reductions from Clean Energy Measures	107
4.2.3 Step 3: Quantify Air Quality Impacts.....	115
4.2.4 Step 4: Quantify Human Health and Related Economic Effects of Air Quality Impacts.....	119
4.3 Case Studies.....	124
4.3.1 Texas Emissions Reduction Plan (TERP).....	124
4.3.2 Wisconsin – Focus on Energy Program	125
Information Resources	127
References	130
CHAPTER FIVE.....	133
Assessing the Economic Benefits of Clean Energy Initiative	
CHAPTER FIVE CONTENTS	
5.1 How Clean Energy Initiatives Create Macroeconomic Benefits.....	134
5.1.1 What are the Direct Effects of Demand-Side Initiatives	135
5.1.2 What are the Direct Effects of Supply-Side Initiatives?	136
5.1.3 What are the Indirect and Induced Effects of Clean Energy Initiatives.....	137

5.2.1 Step 1: Determine the Method of Analysis and Level of Effort.....	138
5.2.2 Step 2: Quantify Expenditures and Savings from the Clean Energy Initiative	148
5.2.3 Step 3: Apply the Method to Quantify Macroeconomic Effects.....	153
5.3 Case Studies.....	154
5.3.1 New York: Analyzing Macroeconomic Benefits of the Energy \$mart Program	154
5.3.2 Illinois: Analyzing the Macroeconomic Benefits of Clean Energy Development	156
Sampling of State Clean Energy Analyses by Type of Analytic Method.....	157
Information Resources	159
References	159
APPENDIX A.....	163
Catalogue of Clean Energy Case Studies Highlighted in the Multiple Benefits Guide	
APPENDIX B.....	185
Tools and Models Referenced in Each Chapter	

This page is intentionally left blank.

Preface

State clean energy initiatives can produce significant savings in fuel and electricity costs, as well as other benefits to the electric system, the environment and public health, and the economy.

Assessing the Multiple Benefits of Clean Energy: A Resource for States helps state energy, environmental, and economic policy makers identify and quantify the many benefits of clean energy to support the development and implementation of cost-effective clean energy initiatives.

This *Resource* identifies the multiple benefits of clean energy and explains why they should be quantified and considered along with costs. It starts by presenting clear, easy-to-understand background information on each type of benefit to help non-specialists understand how the benefits are generated and what can be done to maximize them. Building on that foundation, the *Resource* describes analytic options that states can explore as they conduct and review analyses of clean energy initiatives. It provides a framework for assessing multiple benefits, presenting detailed information on basic and more sophisticated approaches along with descriptions of tools for quantifying each type of benefit. It also includes many examples of how states have used multiple benefits approaches, along with additional resources for more information.

This groundbreaking document is the first to organize and present a comprehensive review of the multiple benefits of clean energy, together with an analytical framework that states can use to assess those benefits during the development and implementation of clean energy policies and programs. *Please Note: While the Resource presents the most widely used methods and tools available to states for assessing the multiple benefits of policies, it is not exhaustive. The inclusion of a proprietary tool in this document does not imply endorsement by EPA.*

This page is intentionally left blank.

CHAPTER ONE

Introduction

Across the nation, states are considering and implementing a variety of clean energy (CE) policies and programs using energy efficiency, renewable energy, combined heat and power (CHP) and clean distributed generation (DG) to meet energy goals such as providing affordable, clean, and reliable energy for their citizens. These policies and programs offer multiple benefits through their ability to:

- Reduce demand for energy;
- Decrease stress on the energy system;
- Mitigate climate change, environmental degradation, and related human health concerns; and
- Promote economic development.

By including the broader set of benefits in the cost-benefit analyses conducted during planning processes, states get more comprehensive assessments of their potential CE investments and are:

- Demonstrating how clean energy policies and programs can help achieve multiple state energy, environmental, and economic benefits in a cost-effective way;
- Designing or selecting clean energy options that offer greater energy, environmental, and economic benefits;
- Identifying opportunities where clean energy can be used to support energy system, environmental, and/or economic development planning strategies across the state; and
- Building support for clean energy policies and programs.

DOCUMENT MAP

○	CHAPTER ONE
○	Introduction
○	CHAPTER TWO
○	Potential Energy Impacts of Clean Energy
○	CHAPTER THREE
○	Electric System Benefits of Clean Energy
○	CHAPTER FOUR
○	Air Quality Benefits of Clean Energy
○	CHAPTER FIVE
○	Economic Benefits of Clean Energy
○	APPENDIX A
○	Catalogue of Clean Energy Case Studies
○	APPENDIX B
○	Tools and Models Referenced in Each Chapter

CHAPTER ONE CONTENTS

1.1	What are the Multiple Benefits of Clean Energy?.....	3
1.1.1	Energy Savings and Renewable Energy Generation: The Foundation for Benefits.....	3
1.1.2	Energy System Benefits.....	3
1.1.3	Environmental and Health Benefits.....	5
1.1.4	Economic Benefits.....	6
1.2	Why Assess the Multiple Benefits of Clean Energy?.....	8
1.2.1	Demonstrating the Multiple Benefits of Clean Energy.....	8
1.2.2	Designing or Selecting Options that Achieve Greater or Broader Benefits.....	8
1.2.3	Identifying Opportunities to Use Clean Energy in Other Planning Processes.....	9
1.2.4	Building Support for Clean Energy Policies and Programs.....	11
1.3	How do States Assess the Multiple Benefits of Clean Energy?.....	11
	References.....	14

WHAT IS CLEAN ENERGY?

Clean energy includes demand- and supply-side resources that meet energy demand with less pollution than that created by conventional, fossil-based generation. Clean energy resources include:

Energy efficiency (EE) – refers to using less energy to provide the same or improved level of service to the energy consumer in an economically efficient way. Energy efficiency measures include a wide variety of technologies and processes, can be implemented across all major energy-consuming sectors, and may affect all energy sources (e.g., natural gas, electricity, etc).

Renewable energy (RE) – energy generated partially or entirely from non-depleting energy sources for direct end use or electricity generation. Renewable energy definitions vary by state, but usually include wind, solar, and geothermal energy. Some states also consider low-impact or small hydro, biomass, biogas, and waste-to-energy to be renewable energy sources. Renewable energy can be generated on site or at a central station.

Combined heat and power (CHP) – also known as cogeneration, CHP is a clean, efficient technology that improves the conversion efficiency of traditional energy systems by using waste heat from electricity generation to produce thermal energy for heating or cooling in commercial or industrial facilities. CHP systems typically achieve 60% to 80% efficiencies, which is significantly higher than those of conventional power plants and separate steam units (<http://www.epa.gov/chp/>).

Clean distributed generation (DG) – refers to small-scale renewable energy and CHP at the customer or end-use site.

For more information, visit the U.S. Environmental Protection Agency's (EPA's) State & Local Climate Web site (www.epa.gov/statelocalclimate) and the ENERGY STAR® Web site (<http://www.energystar.gov/>).

Assessing the Multiple Benefits of Clean Energy: A Resource for States provides states with a framework for evaluating the potential costs and benefits of their clean energy goals, policies, and programs. It shows state analysts how the prospective costs and benefits are derived, enabling them to conduct and manage analyses, review cost and benefit estimates presented to them, and make recommendations about the clean energy options the state should explore or the appropriate evaluation approaches and tools to use. This *Resource*:

- Describes both simple and more sophisticated methods for assessing these benefits;
- Provides guidance on how to choose among methods;

STATE CLEAN ENERGY POLICIES AND PROGRAMS

States implement many policies and programs to advance clean energy, including:

- "Lead By Example" programs where the state increases the use of clean energy in its own government operations, fleets, and facilities;
- Regulatory approaches such as renewable or energy efficiency portfolio standards, appliance standards, building codes, interconnection standards; and
- Funding and incentive programs such as public benefits funds, tax incentives, grants, and revolving loan funds.

For more information on clean energy policies and programs, go to:

- EPA State & Local Climate Web site. www.epa.gov/statelocalclimate/
- *Clean Energy-Environment Guide to Action: Policies, Best Practices, and Action Steps for States* (U.S. EPA, 2006). www.epa.gov/statelocalclimate/resources/action-guide.html
- *State Clean Energy Lead by Example Guide* (U.S. EPA, 2009). www.epa.gov/statelocalclimate/resources/example.html

- Presents examples of how states are conducting multiple benefits analysis and using it to promote clean energy within their states; and
- Offers a wealth of resources, including links to analytical tools, guidance, and studies.

While clean energy resources are broad in source and impact, this *Resource* focuses on guidance for estimating impacts on the electricity system from energy efficiency and other clean energy resources that affect the power system. This focus is not meant to diminish the importance of other clean energy resources—including energy efficiency that reduces demand for both electricity and fossil fuels, and energy supplies from renewables and more efficient use of fossil fuels—but reflects the more complex nature of the analysis required to estimate impacts on the electric system.

This chapter provides an introduction to assessing the multiple benefits of clean energy, including:

- A description of the multiple benefits of clean energy that are covered in this *Resource*, along with examples of the findings from studies that have estimated the actual and potential benefits of a variety of state and regional clean energy initiatives (Section 1.1).

- A discussion of why it is important for states to assess the multiple benefits of clean energy (Section 1.2).
- An overview of the process and approaches involved in prospectively assessing the multiple benefits of clean energy (Section 1.3).

The remainder of the document provides much more detail about estimating potential energy savings of clean energy (Chapter 2) and about assessing the future electric system (Chapter 3), environmental (Chapter 4), and economic (Chapter 5) benefits introduced in this chapter.

1.1 WHAT ARE THE MULTIPLE BENEFITS OF CLEAN ENERGY?

Clean energy affects the demand for and supply of conventional energy and can result in positive effects on the energy system, the environment, and the economy. To quantify these benefits, it is first necessary to understand how they are produced through energy savings and renewable energy generation.

1.1.1 ENERGY SAVINGS AND RENEWABLE ENERGY GENERATION: THE FOUNDATION FOR BENEFITS

Clean energy initiatives reduce energy consumption from fossil fuel generation in two ways:

- Energy efficiency policies and programs lead to direct reductions in energy consumption, which in turn reduces generation requirements.
- Renewable energy and clean distributed supply resources increase the amount of energy from clean (and more efficient) rather than conventional sources.

Demand-side initiatives usually change the end-use efficiency of energy consumption.

Supply-side initiatives usually change the fuel/generation mix of energy supply resources.

States have significant experience quantifying the actual and potential energy impact of clean energy policies. For example:

- A program evaluation of the New York State Energy Research and Development Authority's (NYSERDA) New York Energy SmartSM Program estimated the cumulative annual electricity savings achieved through 2007 at 3,060 GWh from energy efficiency, distributed generation, and combined heat and power. The cumulative annual renewable energy generation through 2007 was 106 GWh (NYSERDA, 2008). Combined, these resources are equivalent to about 2 percent of the amount of electricity generated in New York in 2006.¹

Energy savings and renewable energy generation are important results of state clean energy initiatives and the basis for estimating many of the other benefits of clean energy to the energy system, environment and public health, and the economy. For example:

- An energy efficiency assessment study of the opportunities in the Southwest showed that widespread adoption of cost-effective, commercially available energy efficiency measures in homes and businesses would reduce electricity consumption by 18 percent in 2010 and 33 percent in 2020 with a \$9 billion investment. These energy savings would avoid \$25 billion in annual electricity supply costs and \$2.4 billion in annual natural gas costs (SWEEP, 2002).

This section briefly describes each type of benefit. It also provides examples from recent studies that offer estimates of the multiple benefits of state and regional clean energy programs. A full list of all studies mentioned is presented in Appendix A, *Clean Energy Studies: Summary of Benefits Analyses and Findings*. Additional information about the different types of clean energy options available to states is provided in Appendix A.

1.1.2 ENERGY SYSTEM BENEFITS

Clean energy initiatives—in combination with demand response measures²—can help protect electricity producers and consumers from the costs of adding

¹ *Patterns and Trends: New York State Energy profiles: 1992-2006*. New York State Energy Research Development Authority. January 2008. <http://www.nyserda.org/publications/Patterns%20&%20Trends%20Final%20-%20web.pdf>.

² *Demand response measures aim to reduce customer energy demand at times of peak electricity demand to help address system reliability issues; reduce the need to dispatch higher-cost, less-efficient generating units to meet electricity demand; and delay the need to construct costly new generating or transmission and distribution capacity. Demand response programs can include dynamic pricing/tariffs, price-responsive demand bidding, contractually obligated and voluntary curtailment, and direct load control/cycling (DRAM, 2005).*

CONNECTICUT INCORPORATES MULTIPLE BENEFITS IN EVALUATION CRITERIA FOR NEW CAPACITY ADDITIONS

In June 2005, Connecticut policymakers enacted Public Act 05-01, *An Act Concerning Energy Independence* (EIA), which authorized the Connecticut Department of Public Utility Control to launch a competitive procurement process geared toward motivating new supply-side and demand-side resources in order to reduce the impact of Federally Mandated Congestion Charges on Connecticut ratepayers.

As part of the bid evaluation process, each capacity project is scored based on a multiple benefits weighting system:

- A total of 85% of the evaluation score is based on a benefit-cost analysis of the project.
- A total of 15% of the evaluation score is determined through the assessment of five other criteria with their associated weights:
 - Reduced emissions of SO₂, NO_x, and CO₂ – 5%
 - Use of existing sites and infrastructure – 2.5%
 - Benefits of fuel diversity – 2.5%
 - Front-loading of costs – 2.5%
 - Other benefits (e.g., transmission reliability, employment effects, benefits of high level efficiency such as CHP) – 2.5%

For more information, visit Connecticut's RFP website: <http://www.connecticut2006rfp.com/index.php>

new capacity to the system and from energy supply disruptions, volatile energy prices, and other reliability and security risks. The following four energy system benefits are usually recognized as important ways for clean energy initiatives to reduce the overall cost of electric service over time.

- *Avoided energy generation or wholesale energy purchases.* Clean energy measures can displace energy, specifically electricity, generated from fossil fuels (e.g., natural gas, oil, and coal fired power plants). Savings include avoided fuel costs and reduced costs for purchased power or transmission service.
- *Avoided or reduced need for additional power plant capacity.* Clean energy measures can delay or avoid the need to build or upgrade power plants or reduce the size of needed additions.
- *Avoided or deferred transmission and distribution (T&D) investments.* Clean energy measures, such as customer-sited renewables and clean DG (including CHP), which are sited on or near a constrained portion of the T&D system can delay or avoid the

Many state-level clean energy analyses currently do not quantify emission-related health effects—a clear gap in analysis and understanding.

This gap can be addressed using EPA tools such as COBRA and BenMAP, described in Chapter 4, *Assessing the Air Pollution, Greenhouse Gas, Air Quality and Health Benefits of Clean Energy Initiatives*.

need to build or upgrade T&D systems or reduce the size of needed additions.

- *Avoided energy loss during transmission and distribution (T&D).* The delivery of electricity results in some losses due to the resistance of wires, transformers, and other equipment. For every unit of energy consumption that a clean energy resource avoids, it has the potential to reduce the associated energy loss during delivery of energy to consumers through the T&D system. Distributed resources also reduce these losses by virtue of being closer to the load.

Other energy system benefits that can accrue from clean energy programs include avoided ancillary service costs, reductions in wholesale market clearing prices, increased reliability and power quality, avoided risks (e.g., risks associated with the long lead-time investments for conventional generation and from deferring investments until environmental and climate change policies are known), and improved fuel and energy security.

Many state and regional studies have quantified these benefits. These studies include:

- A study of the Million Solar Roofs initiative in California estimated that the program resulted in avoided capacity investments of about \$7.1 million from 2007–2016 (Cinnamon et al., 2005).
- A study of widespread energy efficiency deployment in the Southwest (introduced in the previous section), used the calculated potential energy savings to estimate avoided capacity investments of about \$10.6 billion by 2020 (SWEEP, 2002).

Analyses also illustrate how clean energy programs can improve the security, diversity, and overall reliability of a state's energy system, which remains a critical energy policy objective in light of the vital link between electric reliability and economic security.

CLEAN ENERGY INITIATIVES CAN BENEFIT ECONOMIC DEVELOPMENT

A 2007 study by the American Solar Energy Society assessed the renewable energy and energy efficiency market and developed forecasts of the market's future economic growth. The study established a baseline of 2006 data describing the size and scope of the renewable energy and energy efficiency industry, and forecast the growth of the renewable energy and energy efficiency industry from this baseline to 2030 under three different scenarios.

Using this approach, the authors developed a case study for Ohio, an area hard hit by the loss of manufacturing jobs. In 2006 in Ohio, gross revenues for renewable energy totaled nearly \$800 million and the renewable energy industry created more than 6,600 jobs, including increased employment among scientific, technical, professional, and skilled workers. The analysis concluded that the energy efficiency and renewable energy industries offer significant development opportunities in the state. In 2030, the renewable energy industry in Ohio could generate nearly \$18 billion in revenues and 175,000 jobs annually, and the energy efficiency industry could generate more than \$200 billion in revenues and more than 2 million jobs annually.

Source: Bezdek, 2007.

- The financial implications of the East Coast blackout in August 2003 help illustrate the importance of a reliable energy system: the blackout, which lasted a couple of days and affected about 20 percent of the U.S. population, was estimated to result in economic losses of \$4.5 to \$10 billion (Conaway, 2006).
- A study of the energy system benefits of energy efficiency and renewable energy in New England from Public Benefits Funds (PBFs) programs and Renewable Portfolio Standards (RPS) concluded that—based on 2004 forecasts from the Capacity, Energy, Load and Transmission (CELT) report from ISO-New England—regional demand-side management activities would reduce peak demand by 1,421 MW from a forecasted peak of 27,267 MW, a reduction of about 5 percent (RAP, 2005).

1.1.3 ENVIRONMENTAL AND HEALTH BENEFITS

Fossil fuel-based electricity generation is a major source of air pollutants that pose serious risks to public health, such as increased respiratory illness from fine-particle pollution and ground-level ozone. Fossil fuel-based generation is also a major source of greenhouse gases (GHGs), such as CO₂, which contribute to global

climate change. States concerned about emissions are turning to clean energy technologies to limit pollution and improve air quality and public health. The air and health benefits of clean energy are summarized below.

- *Reduced criteria air pollutant and GHG emissions.* This Resource focuses on two categories of air emissions from the electricity sector: criteria air pollutant emissions, and GHG emissions. In the electricity sector, clean energy resources can reduce these emissions by displacing fossil fuel generation.³ Reduced emissions of criteria air pollutants—ozone (O₃), carbon monoxide (CO), nitrogen oxides (NO_x), sulfur dioxide (SO₂), particulate matter (PM), and lead (Pb)—are linked directly to changes in air quality and public health effects.⁴ State actions to reduce GHG emissions are tied to reducing the risk of global climate change and generally focus on reducing emissions of CO₂. Criteria and GHG emission reductions are usually measured in tons or as a percentage of some baseline level of emissions.
- *Improved air quality.*⁵ Reduced emissions of criteria pollutants lead to fewer unhealthy air quality days and lower the incidence of public health effects associated with them. Ambient air concentrations of criteria pollutants are usually measured in “parts-per” units such as ppm (parts per million) or in

³ It is important to note that estimating reductions in emissions from clean energy in the presence of market-based emissions programs, such as a cap and trade program, is more complicated. In the presence of an emissions cap and trade program (for example the SO₂ cap and trade program under Title IV of the Clean Air Act Amendments), sources affected by the cap scale back the amount of electricity they generate from affected sources and therefore reduce overall emissions as a result of clean energy. However, because the program allows these sources to emit up to the number of allowances they hold, they may adjust their compliance decisions in a way that allows them to generate these reduced levels of electricity at a higher emissions rate and reduce compliance costs. The allowance price would in theory be reduced. There are ways to capture the environmental benefits from clean energy for pollutants' affected market programs, such as retiring a portion of the allowance associated with the reduction. See *Guidance on SIP Credits for Emissions Reductions from Electric Sector Energy Efficiency and Renewable Energy*. U.S. EPA, Office of Atmospheric Programs, August 5, 2004. http://www.epa.gov/ttncaaa1/t1/memoranda/ereseerem_gd.pdf

⁴ In addition to being a major source of criteria air pollutants and greenhouse gases, coal-burning power plants are the largest human-caused source of mercury emissions to the air in the United States, accounting for over 50% of all domestic human-caused mercury emissions (<http://cfpub.epa.gov/eroe/index.cfm?fuseaction=detail.viewInd&lv=list.listByAlpha&r=188199&subtop=341>). This Resource, however, does not address methods to assess hazardous air pollutants, like mercury.

⁵ Improved air quality represents only one of a broad set of environmental benefits that may accompany clean energy development. Other potential benefits include improved water quality and improved aquatic habitat. This Resource focuses on improved air quality and human health

mass per volume units such as $\mu\text{g}/\text{m}^3$ (micrograms per cubic meter).⁶

- *Improved public health.* Improvements in air quality can reduce the adverse public health effects resulting from exposure to air pollution and reduce the costs of associated public health risks. Public health effects include premature mortality and exacerbation of health conditions such as asthma, respiratory disease, and heart disease.

Studies of the environmental benefits of clean energy initiatives tend to either focus on specific emission reduction objectives or analyze the overall emission reductions of multiple pollutants, including GHGs and criteria pollutants. Examples of these studies include:

- A Texas Emissions Reduction Plan (TERP) analysis in 2004 assessed the potential for clean energy to help meet NO_x air quality requirements as part of a State Implementation Plan (SIP) and found that NO_x emissions would be reduced by 824 tons per year in 2007 and 1,416 tons per year in 2012 (Haberl et al., 2004). Texas NO_x emissions from electricity generation were 140,676 tons in 2005, so these reductions represent 0.5 percent and 1 percent of 2005 emissions, respectively (USEPA, 2007).
- A 2007 Wisconsin study measured CO_2 , SO_2 , and NO_x emission reductions from the state's *Focus on Energy* program and found annual emission displacements of 1,365,755 tons of CO_2 , 2,350 tons of SO_2 , and 1,436 tons of NO_x from 2001 through 2007 (Wisconsin, 2007).⁷ These reductions respectively represent about 2 percent, 1 percent, and 2.5 percent of Wisconsin emissions in 2005 (USEPA, 2007).

These and other studies demonstrate that clean energy initiatives can reduce emissions of both criteria air pollutants and GHGs. States may thus find it valuable to quantify the full range of emission benefits for policy support purposes.

Fewer studies have quantified the public health benefits of clean energy initiatives. Methods to translate emissions reductions into changes in air quality and associated health benefits can be complicated, and until recently they have not been as accessible to states as

methods to assess emissions benefits. One study that did report health effects provides some indication of the magnitude of potential health benefits associated with policies targeting GHG emissions. This study analyzed how actions to reduce GHG emissions from fossil fuel use can also reduce conventional air pollutants in the United States. It found that NO_x -related morbidity and mortality benefits, per ton of carbon reduced, range from \$7.5–\$13.2 dollars under different carbon tax scenarios. In addition, the study reviewed 10 prior studies that estimated health and visibility benefits on a “per ton of carbon reduced” basis, finding these benefits to range from \$3–\$90 per ton of carbon emissions reduced (Burtraw et al., 2001).

1.1.4 ECONOMIC BENEFITS

Clean energy can create broad and diverse economic benefits that vary considerably across economic sectors and over time. Many of the energy system, environmental, and human health benefits of clean energy described above yield overall economic benefits to the state.

Key economic benefits include:

- *Energy Cost Savings.* Measures that reduce consumers' demand for energy result in energy cost savings to consumers.⁸ Once energy savings are known, energy cost savings can be estimated by applying a cost factor (e.g., \$/kWh) to the energy savings estimate. Energy cost savings are typically reported in total dollars saved.
- *Human Health Benefits.* Clean energy policies that reduce criteria air pollutants may improve air quality and avoid illnesses and deaths as described above. Avoided illnesses result in reductions in sick days taken by employees, increases in productivity, and decreases in hospitalizations associated with upper and lower respiratory illnesses and cardiac arrest. Avoided deaths of workers can result in continued economic benefits to the state.
- *Employment.* Clean energy initiatives create temporary, short-term jobs as well as long-term jobs—both directly from the clean energy activities and indirectly via economic multiplier effects. Employment effects of clean energy can be expressed by many different indicators, such as the full-time equivalent (FTE) number of jobs or job-years created. Because an initiative can generate

⁶ For more information on the National Ambient Air Quality Standards (NAAQS), see <http://www.epa.gov/ttn/naaqs/>.

⁷ Emission reductions were presented in pounds in the Wisconsin report but converted to short tons to simplify comparisons in this document.

⁸ Measures that reduce energy demand may also result in lost revenues for energy suppliers, at least in the short term.

OTHER ECONOMIC BENEFITS TO CONSIDER: REDUCING NATURAL GAS PRICES THROUGH INCREASED DEPLOYMENT OF RENEWABLE ENERGY AND ENERGY EFFICIENCY

A recent study by the Lawrence Berkeley National Laboratory (LBNL) examined several studies of the natural gas consumer benefits from clean energy programs, and analyzed their results in the context of economic theory. Most of the studies evaluated a national or state RPS, or a combined RPS and EE program.

Studies in the LBNL analysis consistently found that “RE and EE deployment will reduce natural gas demand, thereby putting downward pressure on gas prices” (Wiser et al., 2005). While the natural gas price reductions vary considerably from state to state, the analysis did offer some broad conclusions:

- Each 1% reduction in national gas demand is likely to lead to a long-term average reduction in wellhead gas prices of 0.8% to 2%.
- Most of the studies that were reviewed and that evaluated national RPS proposals, found the present value of natural gas bill savings from 2003-2020 within the range of \$10 - \$40 billion.
- Consumers’ gas bill savings from development of RE and EE for electric power generation and consumption are estimated between \$7.50 and \$20 for each megawatt hour (MWh) of electricity produced by RE or saved with EE.

Source: Wiser et al., 2005

both employment gains and losses and because employment effects are likely to vary over time, it is important for a comprehensive analysis of clean energy initiatives to assess not only the quantity of jobs created (or eliminated), but also the type, duration, and distribution of jobs across the state’s economic sectors.

- **Output.** Economic output is the dollar value of production, including all intermediate goods purchased, and all value added (the contribution of a sector to the economic output). Output depends upon consumption in the local economy, state government spending, investment, and exports of the industries in the state. Clean energy programs can increase output by stimulating new investments and spending within a state.
- **Gross State Product.** Gross state product (GSP) is the sum of value added from all industries in the state, and is analogous to the national concept of GDP. GSP is equal to the state’s economic output less intermediate inputs acquired from beyond the state. Clean energy has the potential to result in GSP increases.

- **Income.** Income effects from clean energy investments can be measured using a variety of indicators. Most commonly, income effects are expressed as a change in personal income or disposable income. Personal income is the sum of all income received. Disposable income is the income that is available for consumers to spend or save; that is, personal income minus taxes and social security contributions, plus dividends, rents, and transfer payments. In both cases, a net increase in income associated with clean energy initiatives can occur due to increased employment or wages.

Most economic analyses of clean energy initiatives report results in terms of effects on income, output, and employment. In several instances, benefit findings are summarized in terms of the expected benefit per dollar invested in a clean energy program or per dollar of energy savings. These values can vary significantly depending upon the type of value being estimated and upon the assumptions used to estimate them.⁹ Examples of findings on the economic effects of energy efficiency and renewable energy programs include:

- **Illustrative findings for income and output**
 - Every \$1 spent on concentrated solar power in California produces \$1.40 of additional GSP (Stoddard et al., 2006).
 - Every \$1 spent on energy efficiency in Iowa produces \$1.50 of additional disposable income (Weisbrod et al., 1995).
 - Every \$1 million in energy savings in Oregon produces \$1.5 million of additional output and about \$400,000 in additional wages per year (Grover, 2005).
- **Illustrative findings for employment effects**
 - Every \$1 million of energy efficiency net benefits in Georgia produces 1.6–2.8 jobs (Jensen and Lounsbury, 2005).
 - Every \$1 million invested in energy efficiency in Iowa produces 25 job-years, and every

⁹ It is important to understand how any benefit per dollar spent was generated. For example, some values—net values—consider the opportunity cost of how the investment in clean energy could have otherwise been spent. Others do not consider this cost and may depict a higher return per dollar invested. For another example, employment benefits may be measured in job-years, which can be short-lived, and are not the same as net jobs, which are permanent, longer term positions. For more information about how values are calculated and key questions to consider, see Chapter 5, Section 5.1.

\$1 million invested in wind produces 2.5 job-years (Weisbrod et al., 1995).¹⁰

- ▶ Every \$1 million invested in wind or PV produces 5.7 job-years, versus 3.9 job-years for coal power (Singh and Fehrs, 2001).

1.2 WHY ASSESS THE MULTIPLE BENEFITS OF CLEAN ENERGY?

States have historically evaluated clean energy policies based predominantly on their costs and impacts on energy demand. However, by considering the multiple energy system, environmental, and economic benefits of clean energy as they design and select clean energy policies and programs, states can more fully understand the range of costs and benefits of these potential actions. As stated earlier, with this multiple benefits information, states can:

- Demonstrate how clean energy policies and programs can help achieve multiple state energy, environmental, and economic benefits in a cost-effective way;
- Design or select clean energy options that maximize energy, environmental, and economic benefits.
- Identify opportunities where clean energy can be used to support energy system, environmental, and/or economic development planning strategies across the state; and
- Build support for clean energy policies and programs.

1.2.1 DEMONSTRATING THE MULTIPLE BENEFITS OF CLEAN ENERGY

Clean energy policies and programs typically reduce energy demand or increase generation from clean energy sources. Policies and programs are pursued based on an assessment of the costs of the program compared with the results, typically the energy savings or the new supply of clean electricity. For some options (e.g., low-cost energy efficiency measures), cost effectiveness can

¹⁰ The difference in employment effects between energy efficiency and renewable wind power results primarily from the relatively low labor intensity of energy sectors—both renewable and fossil fuel—compared with the economy as a whole. Conserving energy reduces the energy bills paid by consumers and businesses, thereby enabling ongoing spending of those energy savings on non-energy goods, equipment, and services in sectors of the economy that employ more workers per dollar received.

be easy to demonstrate because the direct, near-term benefits are recognized through less consumed energy and lower energy costs. However, other project types (e.g., renewable technologies, higher-cost energy efficiency measures) require higher initial capital costs, and may not result in net savings for many years.

When evaluating these types of options on a cost basis alone, the savings may not exceed the costs during the short payback period defined by many investors and utilities (i.e., high discount rates), limiting interest in the higher investment options.

Most clean energy options, however, result in additional benefits that are frequently left out of the cost-benefit equation. This omission understates the benefits of the programs and can limit the use of clean energy to address multiple challenges. By developing and sharing information about the multiple benefits of clean energy, states can help build support for their programs and encourage other states to implement similar clean energy programs.

For example, the governor of a state may have set renewable energy goals that are to be achieved through the state's clean energy programs. The same state may also have economic development challenges, electricity congestion, or areas of nonattainment under National Ambient Air Quality Standards and not realize the extent to which the clean energy programs implemented to achieve the renewable energy goals also achieve these other goals by reducing stress upon the electricity system, reducing GHGs and air pollution, and achieving public health benefits. By evaluating the potential energy, economic, and environmental impacts of a clean energy program, a state can more fully appreciate the range of its benefits and better understand its cost-effectiveness. Demonstrating these findings both within and outside the state will help the state gain needed buy-in for its clean energy program from state officials, policy makers, and stakeholders, and encourage other states to implement similar clean energy programs.

1.2.2 DESIGNING OR SELECTING OPTIONS THAT ACHIEVE GREATER OR BROADER BENEFITS

Clean energy policies are typically recommended or implemented based on their potential to meet a specific goal—usually energy-related—as set by the state. When selecting among specific clean energy options, however, it is important to develop a set of more specific criteria for determining which options to include in the state clean energy portfolio. Developing these criteria

How Many Jobs Can The Clean Energy Industry Generate?

The University of California-Berkeley reviewed 13 independent reports and developed a model to examine the job creation potential of the renewable energy industry. The study analyzed the employment implications of three national 20% RPS scenarios and two scenarios where the generation required by the RPS is produced instead by fossil-fuel generation.

The key finding is that the renewable energy industry generates more jobs than the fossil-fuel industries per unit of energy delivered and per dollar invested (Kammen et al., 2004). Renewable energy's employment advantage is driven primarily by the general shift from mining and related services to increased manufacturing, construction, and installation activity. The distinction between renewable technologies in terms

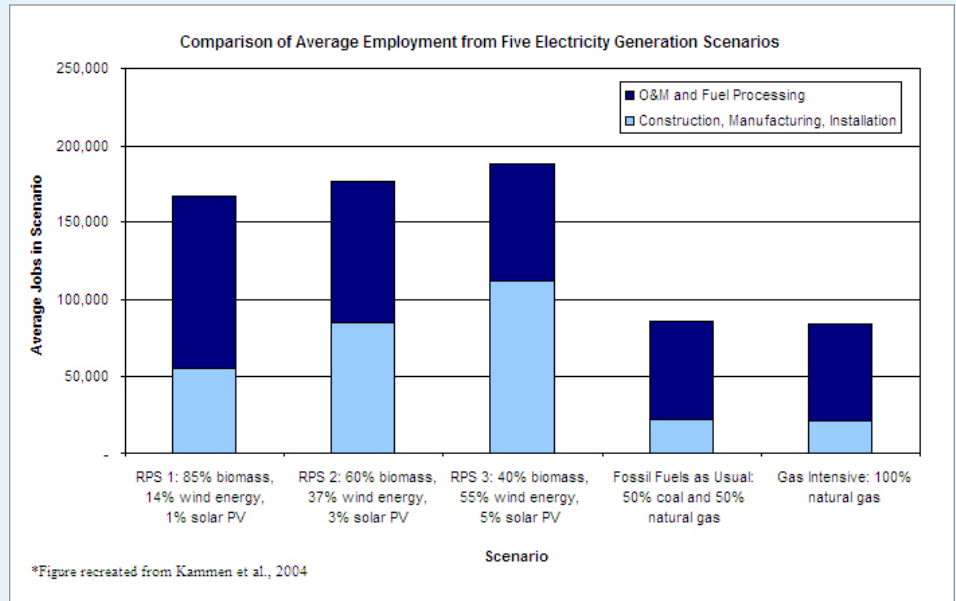

of the number of jobs created in O&M and fuel processing is less clear and technology

dependent. The graph summarizes these findings.*

involves balancing priorities and requirements specific to the state's needs and circumstances. Assessment criteria used by states can involve, for example, energy savings (e.g., in kWh or dollars), economic costs and benefits (e.g., as measured by payback periods, life-cycle costs), environmental impacts (e.g., changes in GHG and air pollutant emissions), economic development (e.g., jobs created or lost), and feasibility (e.g., political feasibility, time frame for implementation).

For example, the Vermont State Agency Energy Plan for State Government stresses the importance of selecting and implementing its clean energy "lead by example" activities based on several criteria: reducing state operating costs through energy savings; reducing environmental impacts; sustaining existing and creating new Vermont businesses that develop, produce, or market environmentally preferable products; and demonstrating the economic benefits of clean energy activities to other states and the private sector (Vermont, 2005). By evaluating potential clean energy activities with criteria that cut across the multiple benefits, Vermont is able to select options that facilitate the achievement of multiple state goals and avoid options that may impede key priorities.

1.2.3 IDENTIFYING OPPORTUNITIES TO USE CLEAN ENERGY IN OTHER PLANNING PROCESSES

Many opportunities exist for states to integrate their clean energy programs with other state environmental, energy system, and economic programs. States can also use the multiple benefits from clean energy programs to help support and strengthen their environmental, energy planning, and economic development programs.

Using Clean Energy to Achieve Environmental Goals

Many states and regions are incorporating clean energy into their environmental strategies to meet their air quality and climate change objectives. Quantifying the multiple benefits of clean energy programs can provide key data for use in developing the SIPs, GHG emissions reduction plans, and air pollution and/or GHG emissions cap and trade programs that include clean energy programs. For example, in 2001, the 77th Texas Legislature established the Texas Emissions Reduction Plan (TERP) with the enactment of Senate Bill 5 (SB 5), and recognized that energy efficiency and renewable energy measures can make an important contribution to meeting National Ambient Air Quality Standards in the state. The 78th Legislature further enhanced the use of clean energy measures to meet the TERP goals

by requiring the Texas Commission on Environmental Quality to promote energy efficiency and renewable energy to meet ambient air quality standards (for more information about the TERP, see Case Studies in Chapter 4, *Assessing the Air Pollution, Greenhouse Gas, Air Quality, and Health Benefits of Clean Energy Initiatives*).

States are relying heavily upon clean energy measures in their climate change action plans to reduce CO₂ emissions from the electric power sector. Other states or regions are using clean energy to advance reductions under their SO₂ and NO_x cap and trade programs. For example, set-asides or carve-outs reserve a portion of the total capped allowances to be distributed to clean energy initiatives. Renewable energy and energy efficiency programs are also being used as offsets in cap and trade programs focused on reducing GHG emissions. For example, the Regional Greenhouse Gas Initiative (RGGI) has developed an offset program in which heating oil and natural gas efficiency improvements, landfill gas projects, and projects that reduce sulfur hexafluoride (SF₆) can be used as emission reductions. Additional renewable energy and energy efficiency programs are expected to qualify in the future.

Using Clean Energy to Achieve Energy Planning Goals

Many state and regional energy plans include clean energy activities and goals. States analyze the benefits of these goals to provide a basis for determining which clean energy initiatives to include in the plan. States can also require utilities to develop plans that are consistent with these state goals. Utilities are required to file either integrated resource plans (IRPs) or portfolio management strategies with the state public utility commission, depending upon whether the state has a regulated or deregulated electric system. These IRPs or portfolio management strategies often use multiple benefits analysis in the program evaluation criteria. For example, California requires consideration of environmental factors in determining cost-effectiveness of supply- and demand-side options. Beginning in 2003, California's Energy Action Plan has defined an environmentally friendly "loading order" of resource additions to meet the electricity needs: first, energy efficiency and demand response; second, renewable energy and distributed generation; and, third, clean fossil-fueled sources and infrastructure improvements (CPUC, 2003).

MULTIPLE BENEFITS ANALYSIS IS BEING USED IN REGIONAL PLANNING

The Conference of New England Governors and Eastern Canadian Premiers (NEG-ECP) seeks to cost-effectively coordinate regional policies that reflect and benefit U.S. states and Canadian provinces. In 2001, it developed a comprehensive Climate Change Action Plan with the long-term goal of reducing GHG emissions in the region by 75–85%. At the 30th annual conference held in May 2006, the Governors and Premiers enacted Policy Resolution 30-2 to promote energy efficiency and renewable energy in the region. Much of the resolution was based on a study that quantified the multiple benefits of existing and expected energy efficiency and renewable energy programs in New England.

The study, *Electric Energy Efficiency and Renewable Energy In New England: An Assessment of Existing Policies and Prospects for the Future*, estimates that by 2010, the combined effect of expected energy efficiency and renewable energy deployment will provide a wide range of benefits that go beyond direct energy savings, including:

Energy System Benefits: the report finds significant benefits to energy security including a stabilizing and reducing influence on the wholesale price of, and demand for, natural gas; reduced wholesale electricity prices in the regional market; reduced demand for new facilities in the electric market; and increased resiliency of the grid.

Environmental Benefits: estimated environmental benefits include savings of 31.6 million tons of CO₂ emissions, 22,000 tons of NO_x emissions, and 34,000 tons of SO₂ emissions between 2000 and 2010.

Economic Benefits: energy efficiency and renewable energy programs are estimated to produce a net positive \$6.1 billion for the New England economy, more than 28,000 job-years, and \$1 billion in wages.

Source: RAP, 2005.

Using Clean Energy to Achieve Economic Development Goals

Clean energy measures yield economic benefits that can affect businesses, industry, consumers, and households. Clean energy can create short-term jobs during the construction of clean energy facilities as well as permanent long-term employment. Sustained investment in clean energy can lead to local jobs in manufacturing, distribution, retail sales, installation, auditing and rating, and maintenance of equipment and technology. Cost-effective clean energy can increase regional economic output and reduce energy bills. As a result, many states are looking to measure and promote the employment and other economic development benefits of clean energy, and to incorporate these benefits into their economic development

planning processes. In July 2008, for example, Pennsylvania Governor Rendell announced and signed The Alternative Energy Investment Fund. This fund was created to invest \$665.9 million into alternative energy, including \$237.5 million specifically targeted toward helping consumers conserve electricity and to manage higher energy prices, and \$428.4 million to spur the development of alternative energy resources and to create at least 10,000 well-paying jobs in these industries (Pennsylvania, 2008; Wall Street Journal, 2008).

1.2.4 BUILDING SUPPORT FOR CLEAN ENERGY POLICIES AND PROGRAMS

By quantifying and promoting the multiple benefits of planned clean energy programs, states can address barriers by raising awareness and building support from key decision-makers and stakeholders by illuminating strategic tradeoffs among energy resources. For example, Connecticut's Climate Change Action Plan is aimed at reducing GHG levels to 1990 levels by the year 2010 and an additional 10% below that by 2020. The plan evaluated 55 action items, including a large number of clean energy activities. Connecticut found that demonstrating the anticipated multiple benefits early in the Action Plan development process, and involving numerous stakeholders in this process, were key to promoting the plan and obtaining the support of multiple stakeholders (see text box *Connecticut Incorporates Multiple Benefits in Evaluation Criteria for New Capacity Additions*) (CCC, 2005).

1.3 HOW DO STATES ASSESS THE MULTIPLE BENEFITS OF CLEAN ENERGY?

The preceding sections described how states are advancing clean energy policies and programs and the importance of assessing the multiple benefits of these policies and programs. This section provides an overview of how states conduct multiple benefits analyses and key issues for states to consider as part of the analyses.

Figure 1.3.1 illustrates the relationships among the multiple benefits of clean energy. As shown in the figure, while energy savings may be a primary goal of clean energy policies and programs, other benefits also accrue from these investments. These benefits are estimated based, in part, on the energy savings estimates,

and in many cases may also be used as inputs for estimating one or more of the other benefits.

It is not necessary for a state to evaluate all of the multiple benefits of clean energy. Typically, a state's priorities and the purpose of its analysis influence which benefits are of most interest. Understanding the relationship between the benefits, however, can help states decide how to go about evaluating the benefits of interest.

As an example of how the different benefits of clean energy are related, consider a state that is contemplating a suite of energy efficiency programs. Based on funding levels and assumptions about participation in the programs, the state can estimate the direct energy savings likely to accrue from them. The benefits, however, do not end there. A state can use the energy savings estimates to evaluate the benefits of the programs on the state's energy system, economy, environment, and public health. For example, the energy demand reduction could be large enough to delay or eliminate the need to construct new conventional power plants, which can be quite costly. This would be a benefit to the energy system. The decrease in the generation of fossil-fuel-based electricity may result in a reduction in GHG emissions and/or criteria air pollutants. Criteria air pollutant reductions affect air quality and could lead to public health benefits. These benefits can be estimated and assigned an economic value. Consumers would enjoy reduced energy costs, which could lead to an increase in spending on non-energy products and services. The economic benefits of the public health improvements (e.g., improved productivity from reduced sick days), energy cost and system savings, and investments in energy efficient equipment would likely stimulate the economy and create jobs.

States can take the following steps when planning and conducting an analysis of a clean energy policy, activity, or program that examines some or all of these clean energy benefits:

- *Determine which clean energy goals, policies, activities, and/or programs to evaluate.* When estimating the multiple benefits of their clean energy policies and programs, states can choose to focus on the benefits of a single clean energy activity (e.g., retrofitting a single state government building) or an entire program (e.g., the state's portfolio of energy efficiency activities, RPS, or green purchasing program). The clean energy activities selected for assessment can be identified, for example, based on the state's overall energy policy and planning goals,

FIGURE 1.3.1 RELATIONSHIP BETWEEN ENERGY SAVINGS & OTHER BENEFITS OF CLEAN ENERGY INITIATIVES

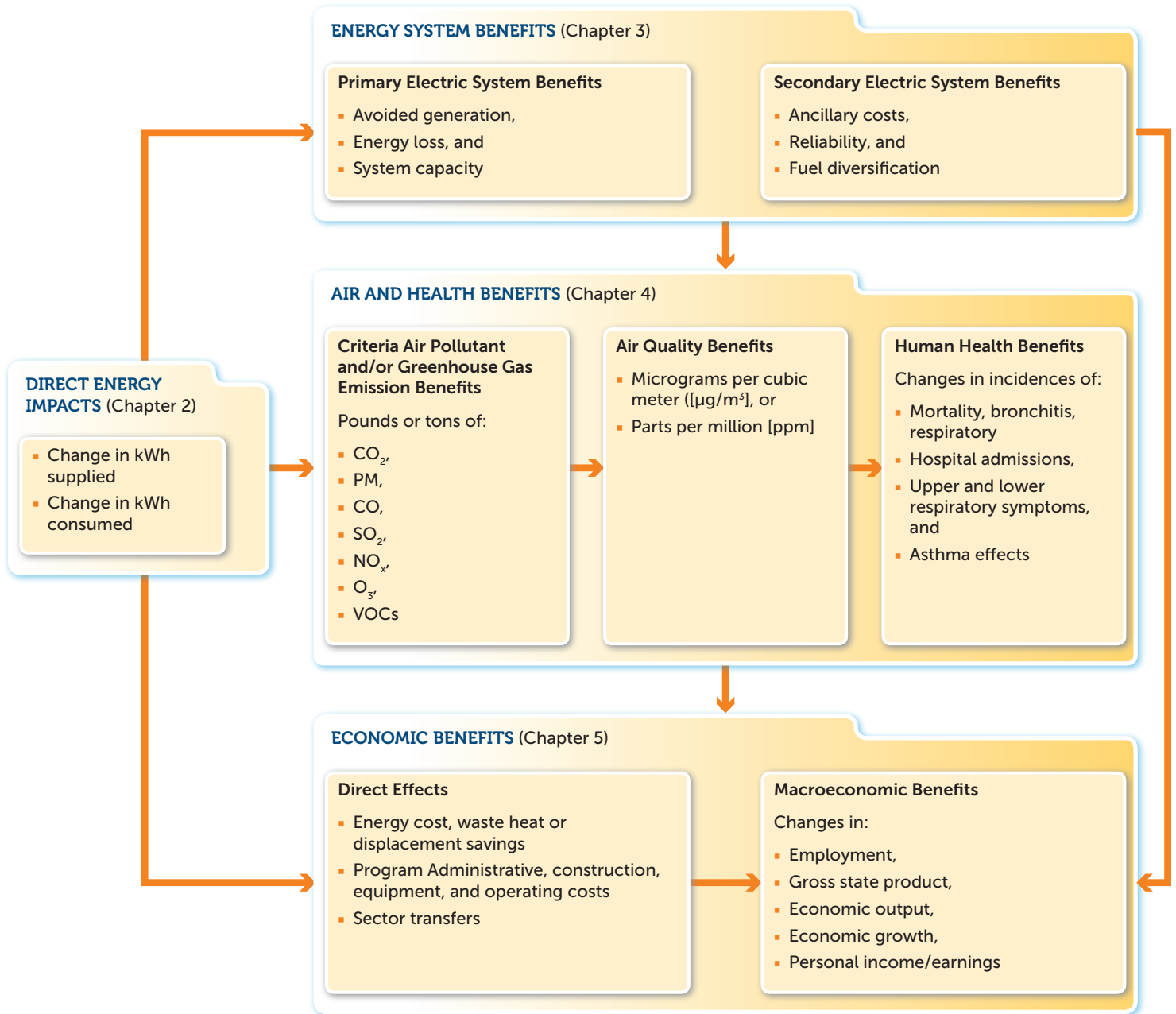

regulatory or legislative requirements, or findings from existing potential studies for energy efficiency and/or renewable energy that provide important information on which activities are most likely to result in energy savings and other benefits.

- *Determine the goals and objectives of the multiple benefits analysis.* It is important to lay out the ra-

tionale for conducting a benefits analysis. Issues to consider include:

- *Why is the analysis being conducted?* As described in Section 1.4, there are many reasons to analyze the benefits of a state's clean energy initiatives. For example, states can consider whether the information will be used primarily to gain support for their initiative; to help

Modeling Approaches

This *Resource* describes a broad range of modeling approaches that may be applied to estimating energy savings, costs, emissions and other impacts of clean energy resources. In an effort to guide decision-making, the *Resource* distinguishes between “sophisticated” modeling approaches that may require significant financial and time commitments, and “basic” approaches that require fewer resources and may more easily be implemented by the state’s own staff. This distinction is somewhat imprecise, as model sophistication could actually be judged along a very broad continuum; nonetheless, the distinction helps convey in broad strokes how approaches to multiple benefit analyses can differ. For purposes of this discussion:

- **Basic approaches** (e.g., spreadsheet analyses, trend extrapolations) tend to be characterized by a relatively simple formulation, such as the use of activity data (e.g., changes in generation levels) and factors (e.g., emissions factors). In these approaches there is no attempt to represent the underlying system (generation dispatch), but instead they rely on factors or trends to capture what would be expected to result. In the example above, the emissions factor is meant to represent the average of what would actually be displaced by a clean energy resource that operates over a long period of time and under varying conditions.

These factors and other inputs may be based on the results of more sophisticated modeling performed by others. Simpler approaches can provide a reasonable level of precision, depending on the nature and source of the parameter. Each user will have to assess whether the method and results are suitable for the intended purpose.

- **Sophisticated approaches** tend to be characterized by extensive underlying data and relatively complex formulation that represents the fundamental engineering and economic decision making of the entity (e.g., power sector system dispatch or capacity expansion modeling), or complex physical processes (such as in air dispersion modeling). Sophisticated models generally provide greater detail than the basic methods, and can capture the complex interactions within the electricity market and with other markets or systems. They can be used to inform discussions of what should happen (optimization) or what might happen given certain assumptions (simulation). These approaches are generally appropriate for short- or long-term analyses, or analyses in which unique demand and supply forecasts are needed to incorporate the specific changes being considered (e.g., implementation of a renewable portfolio standard).

Regardless of what approach is chosen, it is important to understand the strengths and limitations of the method or model. Specifically, it is important to recognize the following:

- Models are mathematical representations of physical or economic processes in the real world; therefore, these tools are only as good as our understanding of these processes. The results will be influenced by the model formulation. For example, an optimization model tells us what we should do under the assumed conditions and represents the “best” or least cost approach. A simulation model, potentially with logit functions or market share algorithms, will help us understand what might happen. Simulation models offer insights into how a complex system responds to changing conditions and specific assumed conditions.
- Data inputs and key driving assumptions have a fundamental effect on the outcomes, some more than others.
- What actually occurs (or has occurred) will depend on what values these key drivers ultimately take. For all, there is some degree of uncertainty: fuel prices, weather, unit availability, load levels and patterns, technology performance, future market structure and regulatory requirements, to name only a few, all have considerable uncertainties surrounding them. However, the strength of models, particularly those bottom-up models with engineering-economic detail, is that they provide a consistent framework for understanding how a system responds to different stimuli and to characterize the uncertainty surrounding our best estimates.

design a clean energy program and select the specific activities to include in the program, provide data for a regulatory purpose (e.g., a SIP or cap and trade program); or to support related environmental, planning, or economic development policy and program decisions.

- *Which benefits will be analyzed?* States can concentrate on estimating some or all of the multiple benefits of their clean energy activity or program, depending on the purpose and scope of the initiative. This decision will depend on the audience and their interests, available financial and staff resources, and the type and scope of the clean energy initiative(s) being assessed. For example, when deciding whether to conduct an energy efficiency retrofit of a single building, states may want to estimate the energy savings and GHG

emission reductions of other building retrofit options and use this information to select the likely candidate for retrofitting. When developing a clean energy plan or assessing a more extensive clean energy initiative, it may be more appropriate to assess a broad range of benefits and use this information to help build widespread support for the program.

- *Determine how to conduct the analysis.* Multiple benefits analyses can employ a variety of approaches, ranging from basic screening estimates and spreadsheet analyses to more sophisticated modeling approaches. States will consider a variety of issues when determining the most appropriate approach for their needs and circumstances, and will balance competing factors as necessary—for example, the scope and rigor of the analysis may

be balanced against the level of resources available. Key issues include:

- ▶ *What financial and staff resources are available?*
- ▶ *What other kinds of expertise (e.g., in-house staff and outside consultants) are available?*
- ▶ *Do data exist from similar analyses or for other states or regions? Or will a new analysis be required?*
- ▶ *Is the analysis retrospective (an historical assessment) or prospective (forward-looking)?*
- ▶ *What level of rigor is required? Is it for regulatory purposes or a preliminary screening of options?*
- ▶ *Will the analysis entail an iterative approach where the state explores a wide range of options using screening methods and then conducts a more comprehensive analysis of only the most promising options?*

More detailed information about how to estimate the potential benefits of clean energy initiatives is

presented in the remaining chapters of the *Resource*, as follows:

- Chapter 2: Assessing the Potential Energy Impacts of Clean Energy Initiatives.
- Chapter 3: Assessing the Electric System Benefits of Clean Energy Initiatives.
- Chapter 4: Assessing the Air Pollution, Greenhouse Gas, Air Quality, and Health Benefits of Clean Energy Initiatives.
- Chapter 5: Assessing the Economic Benefits of Clean Energy Initiatives.

Each chapter describes approaches for calculating or estimating prospective benefits based on varying levels of rigor and provides examples of states' experiences using multiple benefits analysis to promote clean energy. The chapters provide general information on how to conduct and evaluate analyses of multiple benefits, rather than serving as a detailed workbook for quantifying benefits. Taken as a whole, these chapters provide a framework for states to use in determining the likely benefits of their clean energy goals, policies, and programs and using this information to support these initiatives.

References	URL Address
Bezdek, Roger. 2007. Renewable Energy and Energy Efficiency: Economic Drivers for the 21st Century. Prepared for the American Solar Energy Society.	http://www.greenforall.org/resources/renewable-energy-and-energy-efficiency-economic
Bluestein, J., E. Salerno, L. Bird, and L. Vimmerstedt. 2006. Incorporating Wind Generation in Cap and Trade Programs. National Renewable Energy Laboratory (NREL) Technical Report. NREL/TP-500-40006. July.	http://www.eere.energy.gov/windandhydro/windpoweringamerica/pdfs/wpa/policy_cap_trade.pdf
Burtraw, D., A. Krupnick, K. Palmer, A. Paul, M. Toman, and C. Bloyd. 2001. Ancillary Benefits of Reduced Air Pollution in the United States from Moderate Greenhouse Gas Mitigation Policies in the Electricity Sector. Resources for the Future, Discussion Paper 01-61. December.	http://www.rff.org/Documents/RFF-DP-01-61.pdf
Connecticut Climate Change. 2005 Connecticut Climate Action Plan Web Site.	http://www.ctclimatechange.com/StateActionPlan.html
CPUC. 2003. Energy Action Plan. Adopted May 8.	http://docs.cpuc.ca.gov/published/report/28715.htm
Cinnamon, B., T. Beach, M. Huskins, and M. McClintock. 2005. The Economics of Solar Power for California. White Paper. August.	http://akeena.net/Library/pdfs/Economics_of_Solar_Power_for_California_Aug2005.pdf
Clean Air Report (via InsideEPA.com). 2006. States, Utilities Divided Over Role of Carbon In Building New Plants. CLEANAIR-17-25-10. December 14.	N/A

References	URL Address
Clemmer, S., B. Grace, and K. Cory. 2003. A Study to Evaluate the Impacts of Increasing Wisconsin's Renewable Portfolio Standard. Prepared for the University of Wisconsin-Madison and the Wisconsin Division of Energy. October.	http://energytaskforce.wi.gov/docview.asp?docid=2
Conaway, C. 2006. The Challenge of Energy Policy in New England. Federal Reserve Bank of Boston, New England Public Policy Center. April.	http://www.bos.frb.org/economic/neppc/wp/2005/neppcwp0502.htm
Deyette, J., S Clemmer. 2005. Increasing the Texas Renewable Energy Standard: Economic and Employment Benefits. Prepared for Union Of Concerned Scientists.	http://www.ucsusa.org/assets/documents/clean_energy/texas_res_report-02-05_final.pdf
DRAM. 2005. Demand Response and Advanced Metering Coalition.	http://www.dramcoalition.org/id19.htm
EIA. 2008. Annual Energy Outlook 2008. DOE/EIA-0383(2008). U.S. Energy Information Administration, Washington, DC. June.	http://www.eia.doe.gov/oiaf/archive/aeo08/index.html
Energy Trust of Oregon. 2005. Cost-Effectiveness Policy and General Methodology for the Energy Trust of Oregon (4.06.000-P).	http://energytrust.org/library/policies/4.06.000.pdf
Freese, B. and S. Clemmer. 2006. Gambling with Coal: How Future Climate Laws Will Make New Coal Power Plants More Expensive. Union of Concerned Scientists. September.	http://www.ucsusa.org/assets/documents/clean_energy/gambling_with_coal_final_report_sept_06.pdf
Georgia Environmental Facilities Authority (GEFA). 2006a. Georgia Energy Review 2005. Prepared by the GEFA Division of Energy Resources. March.	http://www.gefa.org/Index.aspx?page=93
Georgia Environmental Facilities Authority (GEFA). 2006b. State Energy Strategy for Georgia. Prepared by the GEFA Division of Energy Resources. September 1.	http://www.gefa.org/Index.aspx?page=93
Georgia Office of Communications. 2006. Press Release: Governor Announces Development of Statewide Energy Strategy. March 2.	http://gov.georgia.gov/00/press/detail/0,2668,78006749_90418617_91273717,00.html
Grover, S. 2005. Economic Impacts of Oregon Energy Tax Credit Programs (BETC/RETC). Prepared by ECONorthwest for the Oregon Department of Energy. February.	http://www.oregon.gov/ENERGY/CONS/docs/EcoNW_Study.pdf
Haberl, J., C. Culp, B. Yazdani, D. Gilman, T. Fitzpatrick, S. Muns, M. Verdict, M. Ahmed, Z. Liu, J. Baltazer-Cervantes, J. Bryant, L. Degelman, D. Turner. 2004. Energy Efficiency/Renewable Energy Impact in the Texas Emissions Reduction Plan (TERP). ESL-TR-04/12-01. December.	http://esl.eslwin.tamu.edu/docs/documents/tceq-report-2-14-2005-vol-1.pdf
Jacobson, D., P. O'Connor, C. High, and J. Brown. 2006. Final Report on the Clean Energy/Air Quality Integration Initiative Pilot Project of the U.S. Department of Energy's Mid-Atlantic Regional Office. DOE/GO-102006-2354. August.	http://www.eere.energy.gov/wip/pdfs/40477.pdf
Jensen, V., and E. Lounsbury. 2005a. Assessment of Energy Efficiency Potential in Georgia. Prepared for the Georgia Environmental Facilities Authority by ICF Consulting. May.	http://www.gefa.org/Modules/ShowDocument.aspx?documentid=46
Jensen, V., and E. Lounsbury. 2005b. Strategies for Capturing Georgia's Energy Efficiency Potential. Prepared for the Georgia Environmental Facilities Authority by ICF Consulting. May.	http://www.gefa.org/Modules/ShowDocument.aspx?documentid=45
Kammen, D., K. Kapadia, M. Fripp. 2004. Putting Renewables to Work: How Many Jobs Can the Clean Energy Industry Generate? April.	http://rael.berkeley.edu/old-site/renewables.jobs.2006.pdf

References	URL Address
Nadel, S., A. Shipley, and R.N. Elliot. 2004. The Technical, Economic and Achievable Potential for Energy-Efficiency in the U.S. – A Meta-Analysis of Recent Studies. American Council for an Energy-Efficient Economy, Washington, DC. From the proceedings of the 2004 ACEEE Summer Study on Energy Efficiency in Buildings.	http://www.aceee.org/conf/04ss/rnemeta.pdf
New England Governors and Eastern Canadian Premiers (NEG-ECP). 2003. Resolution 28-7: Resolution Concerning Environmental Projects and Issues. September.	http://www.negc.org/03resolutions/res28_7.html
New England Governors and Eastern Canadian Premiers (NEG-ECP). 2006. Resolution 30-2: Resolution Concerning Energy. May.	http://www.negc.org/resolutions/Res_30-2_5-06.pdf
New England Public Policy Center (NEPPC) and Federal Reserve Bank of Boston. 2005. Fueling the Future: Energy Policy in New England Conference Report 05-2. December.	http://www.bos.frb.org/economic/neppc/conreports/2005/conreport052.pdf
NYSERDA. 2006. New York Energy Smart SM Program Evaluation and Status Report Year Ending December 31, 2005. Report to the System Benefits Charge Advisory Group. Final Report. May.	http://www.nyserda.org/Energy_Information/06sbcreport.asp
NYSERDA. 2008. New York Energy Smart SM Program Evaluation and Status Report: Year Ending December 31, 2007. Report to the System Benefits Charge Advisory Group. Final Report. March.	http://www.nyserda.org/pdfs/Combined%20Report.pdf
Northeast International Committee on Energy (NICE). 2005. 2004-2005 Report to the 29th Conference of New England Governors and Eastern Canadian Premiers on Energy. August.	http://www.cap-cpma.ca/images/pdf/eng/2005_NICE_Report_Final.pdf
Northeast International Committee on Energy (NICE). 2006. Report to the New England Governors and Eastern Canadian Premiers on the Activities of the Northeast Committee on Energy. May.	http://www.cap-cpma.ca/images/pdf/eng/NICE_2006_Annual_Report.pdf
Pennsylvania. 2008. Office of the Governor Web Site. Gov. Rendell Signs Bill Establishing \$650 Million Energy Fund to Support Conservation, Spur Renewable Energy Development. July 9.	http://www.depweb.state.pa.us/news/cwp/view.asp?a=3&q=538660
Prindle, W., A. Shipley, and R. Elliott. 2006. Energy Efficiency's Role in a Carbon Cap-and-Trade System: Modeling the Results from the Regional Greenhouse Gas Initiative. ACEEE Report E064. May.	http://aceee.org/pubs/e064.pdf?CFID=978956&CFTOKEN=15830524
PSE IRP. 2007. Puget Sound Energy 2007 Integrated Resource Plan. Filed with the Washington Utilities and Transportation Commission May 31.	http://www.pse.com/ENERGYENVIRONMENT/ENERGYSUPPLY/Pages/pse2007irpView.aspx
Rabe, B.G. 2002. Greenhouse & Statehouse: The Evolving State Government Role in Climate Change. Pew Center on Global Climate Change. November.	http://www.pewclimate.org/docUploads/states_greenhouse.pdf
Regulatory Assistance Project (RAP). 2005. Electric Energy Efficiency and Renewable Energy in New England: An Assessment of Existing Policies and Prospects for the Future. Prepared by The Regulatory Assistance Project and Synapse Energy Economics, Inc. May.	http://www.raponline.org/Pubs/RSWS-EEandREinNE.pdf
Singh, V. and J. Fehrs. 2001. The Work That Goes Into Renewable Energy. Renewable Energy Policy Project Research Report. November.	http://www.repp.org/articles/static/1/binaries/LABOR_FINAL_REV.pdf
State and Territorial Air Pollution Program Administrators/Association of Local Air Pollution Control Officials (STAPPA/ALAPCO). 2005. Alternative NO _x Allowance Allocation Language for the Clean Air Interstate Rule. Prepared by the State and Territorial Air Pollution Program Administrators (STAPPA) and the Association of Local Air Pollution Control Officials (ALAPCO). August.	http://www.4cleanair.org/Bluestein-cairallocation-final.pdf

References	URL Address
Stoddard, L., J. Abiecunas, and R. O'Connell. 2006. Economic, Energy, and Environmental Benefits of Concentrating Solar Power in California. Prepared by Black & Veatch for U.S. DOE National Renewable Energy Laboratory. April.	http://www.nrel.gov/docs/fy06osti/39291.pdf
Sumi, D., G. Weisbrod, B. Ward, and M. Goldberg. 2003. An Approach to Quantifying Economic and Environmental Benefits for Wisconsin's Focus on Energy. Presented at International Energy Program Evaluation Conference. August.	http://www.edrgroup.com/pdf/sumi-weisbrod-wis-energy-iepec.pdf
SWEEP. 2002. The New Mother Lode: The Potential for More Efficient Electricity Use in the Southwest. Southwest Energy Efficiency Project, Report for the Hewlett Foundation Energy Series. November.	http://www.swenergy.org/nml
U.S. Environmental Protection Agency. 1999. Guidance on Establishing an Energy Efficiency and Renewable Energy (EE/RE) Set-Aside in the NO _x Budget Trading Program. EPA Office of Atmospheric Programs and Office of Air and Radiation. March.	http://www.epa.gov/cleanenergy/energy-programs/state-and-local/guidance.html
U.S. Environmental Protection Agency. 2004a. Guidance on State Implementation Plan (SIP) Credits for Emission Reductions from Electric-Sector Energy Efficiency and Renewable Energy Measures. EPA Office of Air and Radiation. August.	http://www.epa.gov/ttn/oarpg/t1/memoranda/ereeerem_gd.pdf
U.S. Environmental Protection Agency. 2004b. Incorporating Emerging and Voluntary Measures in a State Implementation Plan. EPA Office of Air and Radiation. September.	http://www.epa.gov/ttncaaa1/t1/memoranda/evm_ievm_g.pdf
U.S. Environmental Protection Agency. 2004c. Output-Based Regulations: A Handbook for Air Regulators. EPA Office of Atmospheric Programs, Climate Protection Partnerships Division. August.	http://www.epa.gov/chp/documents/obr_final_9105.pdf
U.S. Environmental Protection Agency. 2005a. Incorporating Bundled Emission Reduction Measures in a State Implementation Plan. EPA Office of Air and Radiation. August.	http://www.epa.gov/ttn/oarpg/t1/memoranda/10885guideibminsip.pdf
U.S. Environmental Protection Agency. 2005b. State Set-Aside Programs for Energy Efficiency and Renewable Energy Projects Under the NO _x Budget Trading Program: A Review of Programs in Indiana, Maryland, Massachusetts, Missouri, New Jersey, New York, and Ohio (Draft Report). EPA Office of Atmospheric Programs. September.	http://www.epa.gov/cleanenergy/documents/eere_rpt.pdf
U.S. Environmental Protection Agency. 2006. Clean Energy-Environment Guide to Action: Policies, Best Practices, and Action Steps for States. April.	http://www.epa.gov/statelocalclimate/resources/action-guide.html
U.S. Environmental Protection Agency. 2007. Emissions & Generation Resource Integrated Database (eGRID), eGRID2007 Version 1.1.	http://www.epa.gov/egrid
U.S. Environmental Protection Agency. 2008. Clean Energy Policy Maps Web Site. August.	http://www.epa.gov/statelocalclimate/state/tracking/index.html
Vermont. 2005. Vermont State Agency Energy Plan for State Government.	http://bgs.vermont.gov/sites/bgs/files/pdfs/BGS-VTStateEnergyPlan.pdf
Wall Street Journal. 2008. Market Watch. PA Governor Rendell Says Clean Energy Projects Will Create Jobs, Promote Conservation, Efficiency. October 20.	http://www.marketwatch.com/news/story/pa-governor-rendell-says-clean/story.aspx?guid={49A81C90-F822-4FBC-88F5-55B6D0D8899E}&dist=hppr
Weisbrod, G. and B. Weisbrod. 1997. Measuring Economic Impacts of Projects and Programs. Economic Development Research Group. April.	http://www.smartbrief.com/news/aaa/industryPR-detail.jsp?id=1C2429AC-1174-48E0-8FB3-E84476F6C1C3

References	URL Address
Weisbrod, G., K. Polenske, T. Lynch, and X. Lin. 1995. The Long-Term Economic Impact of Energy Efficiency Programs and Renewable Power for Iowa: Final Report. Economic Development Research Group, Boston, MA. December.	http://www.edrgroup.com/library/energy-environment/iowa-energy.html
Western Governors' Association (WGA). 2006a. Energy Efficiency Task Force Report. Final report to the Clean and Diversified Energy Advisory Committee (CDEAC). January.	http://www.westgov.org/wga/initiatives/cdeac/EnergyEfficiency-full.pdf
Western Governors' Association (WGA). 2006b. Clean Energy, a Strong Economy and a Health Environment. Report of the Clean and Diversified Energy Advisory Committee (CDEAC) to the Western Governors. June.	http://www.westgov.org/wga/meetings/am2006/CDEAC06.pdf
Wisconsin Office of the Governor. 2006. Press Release: Governor Doyle Signs Senate Bill 459, Bipartisan Energy Efficiency and Renewables Legislation. March 17.	http://www.wisgov.state.wi.us/journal_media_detail.asp?locid = 19&prid = 1830
Wisconsin Public Service Commission. 2007. Public Service Commission of Wisconsin Focus on Energy Evaluation Semiannual Report (FY07, Year-end) Final: September 11, 2007 Revised: November 1.	http://www.focusonenergy.com/files/Document_Management_System/Evaluation/semiannualevaluation07_evaluationreport.pdf
Wiser, R., M. Bolinger, and M. Clair. 2005. Easing the Natural Gas Crisis: Reducing Natural Gas Prices through Increased Deployment of Renewable Energy and Energy Efficiency. Ernest Orlando Lawrence Berkeley National Laboratory (LBNL). January.	http://eetd.lbl.gov/ea/ems/reports/56756.pdf
Xcel Energy. 2006. Petition to the Minnesota Public Utilities Commission to Initiate a Competitive Resource Acquisition Process for 375 MW of Base Load Generation. November.	https://www.edockets.state.mn.us/EFiling/ShowFile.do?DocNumber=4717612

CHAPTER TWO

Assessing the Potential Energy Impacts of Clean Energy Initiatives

Amidst rising concerns about energy prices, the availability of reliable energy resources, air quality, and climate change, many states across the country are using clean energy policies to help meet their expanding electricity demand in a clean, low-cost, reliable manner.

- Nearly 40 states are using planning and incentive structures to promote clean energy within their own operations;
- More than 30 states have adopted a number of regulatory and market-based energy efficiency actions that increase investment in cost-effective energy efficiency by consumers, businesses, utilities, and public agencies; and
- More than 40 states have taken energy supply actions to support and encourage continued growth of clean energy supply.¹

These actions result in measurable reductions in demand for conventional fossil-fuel-powered electricity as well as reductions in natural gas used for heating, and/or an increase in the amount of electricity generated with clean, renewable energy sources.

This chapter provides state policymakers with methods and examples they can use to estimate the potential direct energy impacts of electricity-related clean energy options for policy and program planning purposes. By understanding the potential energy savings of these programs and policies, state officials can:

- Demonstrate the energy-related impacts of existing and potential clean energy programs;

¹ For more information about which states have implemented these policies, see: <http://www.epa.gov/statelocalclimate/state/tracking/index.html>

○	CHAPTER ONE
○	Introduction
●	CHAPTER TWO
○	Potential Energy Impacts of Clean Energy
○	CHAPTER THREE
○	Electric System Benefits of Clean Energy
○	CHAPTER FOUR
○	Air Quality Benefits of Clean Energy
○	CHAPTER FIVE
○	Economic Benefits of Clean Energy
○	APPENDIX A
○	Catalogue of Clean Energy Case Studies
○	APPENDIX B
○	Tools and Models Referenced in Each Chapter

CHAPTER TWO CONTENTS

2.1	How Do Clean Energy Policies Affect Energy?	20
2.2	How Can States Estimate the Potential Direct Energy Impacts of Clean Energy Policies?	21
2.2.1	STEP 1: Develop a Business-As-Usual Energy Forecast	22
2.2.2	STEP 2: Quantify Implications of Targets and Goals	33
2.2.3	STEP 3: Estimate Potential Direct Energy Impacts	35
2.2.4	STEP 4: Create an Alternative Policy Forecast	44
2.3	Case Studies	45
2.3.1	Texas Building Code	45
2.3.2	Vermont – Energy and Energy Savings Forecasting	47
	Information Resources	49
	References	50

STATES ARE QUANTIFYING POTENTIAL DIRECT ENERGY IMPACTS OF CLEAN ENERGY INITIATIVES

The New York Energy \$martSM public benefits program, funded through a systems benefit charge, was implemented in 1998 to improve New York's energy reliability, reduce energy costs, mitigate environmental and public health effects related to energy use in New York, and enhance the state economy (NYSERDA, 2008). Each year, the New York State Energy Research and Development Authority (NYSERDA) develops a report for the New York State Public Service Commission on the energy savings and progress toward program and energy savings goals.

Between 1998 and 2004, the program achieved cumulative:

- electricity savings of 1,400 GWh, and
- energy cost savings of \$195 million.

The program was extended in 2005 for an additional five years and the annual budget increased from \$150 million to \$175 million (NYSERDA, 2005; NYSEDA, 2008). The expanded program continues to achieve significant benefits. By year-end 2007, the overall program had achieved more than 3,000 GWh of electricity savings.

Based on these electricity savings estimates and related investments, NYSEDA calculated the cumulative benefits of the Energy \$martSM program through 2007 and found that it:

- Reduced annual energy bills by \$570 million for participating customers,
- Created and retained 4,700 jobs,
- Reduced nearly 2,600 and 4,700 tons of NO_x and SO₂ respectively, and
- Decreased annual CO₂ emissions by 2 million tons (NYSEDA, 2008).

Using projections of New York's clean energy investments and electricity savings, NYSEDA estimated that by 2027 the program will create more than 7,200 jobs, increase labor income more than \$300 million each year, and increase total annual output in the state by \$503 million. This information about progress and benefits will inform future decisions about New York Energy \$martSM program funding (NYSEDA, 2008).

- Evaluate the implications of new goals, targets, or legislative actions;
- Evaluate the feasibility of or progress toward clean energy-related goals or standards;
- Evaluate the actual and potential effectiveness of technology- or sector-specific clean energy programs in achieving energy savings;
- Compare across clean energy options; and

- Evaluate the actual and potential co-benefits of clean energy policies, including benefits to the energy system, economy, environment, and public health.

As illustrated in the text box *States are Quantifying Potential Direct Energy Impacts of Clean Energy Initiatives*, estimates of potential energy savings serve as a foundation for subsequent analysis of multiple benefits and help demonstrate the value of a program. States can conduct similar analyses of their clean energy programs using methods and tools described in the rest of this chapter.

- Section 2.1 provides a brief explanation of how clean energy initiatives affect energy use and electricity generation requirements.
- Section 2.2 describes methods for estimating potential energy savings or renewable energy generation. This section and the remaining chapters of the *Resource* focus on prospective, rather than retrospective, analyses. See the text box *Retrospective versus Prospective Calculation of Energy Savings* for more information.
- Section 2.3 presents case studies that illustrate how states have used some of these approaches to develop a baseline, a business as usual (BAU) forecast, and energy savings or renewable energy forecasts while planning their clean energy policies.

2.1 HOW DO CLEAN ENERGY POLICIES AFFECT ENERGY?

The two primary objectives of clean energy initiatives are typically to:

1. Implement low-cost energy efficiency measures that reduce the demand for energy, and/or
2. Deploy renewable energy systems (both thermal and electric) or highly efficient cogeneration systems to meet energy demand with the cleanest resources available.

Energy efficiency initiatives include energy efficiency savings goals; energy efficiency portfolio standards; public benefit funds for energy efficiency; building codes; appliance standards; revolving loan programs for energy efficiency; energy performance contracting; and

FIGURE 2.2.1 STEPS TO ESTIMATING ENERGY IMPACTS OF CLEAN ENERGY

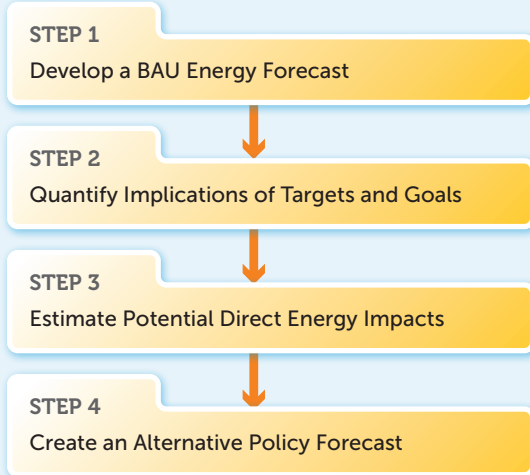

incentives, grants and rebates for efficiency.² Through regulatory, market-based, and voluntary approaches, these programs are designed to advance the deployment of energy efficient technologies. The outcome of efficiency efforts is measured in terms of reduced end-use consumption or energy savings (in kWhs or Btus) and peak demand (MW, or maximum Btu/hour), which reduce the amount of energy demanded from generators or delivered from natural gas producers.³

Renewable energy initiatives include renewable electricity generation and energy goals; renewable energy portfolio standards; public benefit funds for renewable energy; and revolving loan programs, incentives, and grants and rebates for renewable energy investments. Through regulatory, market-based, and voluntary approaches, these programs are designed to advance the deployment of renewable energy fuels and technologies. Power produced by renewable energy generators displaces supply from existing or planned fossil-fueled electricity generation, sometimes described as “avoided energy.”⁴

² These and other clean energy activities are described in the EPA Clean Energy-Environment Guide to Action: Policies, Best Practices, and Action Steps for States (U.S. EPA, 2006).

³ As noted in Chapter 1, while clean energy resources include energy efficiency and energy resources that reduces demand for electricity and fossil fuels, the focus of this Resource is on those that affect electricity demand and/or the electric system.

⁴ The actual impact of incremental renewable energy production on the energy system as a whole is complex and depends on factors such as the timing of production and the baseload requirements of the power grid. These energy system impacts are discussed in Chapter 3.

RETROSPECTIVE VERSUS PROSPECTIVE CALCULATION OF ENERGY SAVINGS

States can assess energy impacts from two perspectives: retrospectively, to evaluate impacts of existing investments, or prospectively, to plan new or modified initiatives. This Resource describes prospective techniques for estimating energy savings or renewable energy generation to help states plan: that is, methods and models that calculate energy impacts expected to occur in the future as a result of the state’s proposed clean energy initiatives. Prospective analyses of energy impacts are appropriate, for example, when a state wants to gain support for a proposed clean energy policy, is assessing the relative costs and benefits of alternative policies in order to select the most cost-effective clean energy approach, or is determining the budget level required to meet clean energy goals.

A retrospective approach, in contrast, is based on measurements of actual impacts that have already accrued from the state’s clean energy actions. Actual energy savings from energy efficiency programs, for example, are calculated using “measurement and verification” (M&V) methods, whereby measurements determine actual savings from measures implemented within an individual facility. Energy savings are calculated using the following approach:

- Select a representative sample of projects.
- Determine the savings of each project in the sample, based on deemed savings values (i.e., claimed savings) or measured savings, energy bills, or calibrated computer simulation.
- Apply the sample project’s savings to the entire population (e.g., the clean energy program).

More information about retrospective calculation of energy savings from energy efficiency is available in the National Action Plan for Energy Efficiency (NAPEE), *Model Energy Efficiency Program Impact Evaluation Guide*, November 2007 (http://www.epa.gov/cleanenergy/documents/evaluation_guide.pdf) and U.S. EPA *Lead by Example Guide*, June 2009 (<http://www.epa.gov/statelocalclimate/resources/example.html>).

These direct energy supply impact estimates are the foundation for calculating potential cost savings and other benefits to the state economy, energy system benefits, and environmental and public health benefits.

2.2 HOW CAN STATES ESTIMATE THE POTENTIAL DIRECT ENERGY IMPACTS OF CLEAN ENERGY POLICIES?

There are four primary steps for estimating the potential direct energy impacts from clean energy policies (see Figure 2.2.1). The first step is to establish a BAU forecast of energy supply and demand. This involves taking a look at the historical demand and supply

portfolio within a state (i.e., developing the baseline) and projecting it forward, based on assumptions about the future. The projection is a BAU forecast that illustrates what state energy demand, consumption, and supply will most likely be in the absence of additional clean energy policies beyond those already considered in resource planning.

This projection can be used in a second step to develop or quantify the implications of an energy-related target if a state is interested.

The third step is to estimate the energy savings (or clean energy supply) from a proposed clean energy initiative or portfolio of initiatives. The energy savings are determined by estimating the impact on energy consumption levels and patterns of a specific policy approach, or the energy output from renewable resources.

The fourth step, creating an alternative policy forecast, allows the state to consider potential outcomes of realizing the direct energy impacts. In the case of efficiency, the energy savings estimates are subtracted from the BAU forecast developed under Step 1 to create a new energy forecast. For clean energy supply alternatives, the impacts estimates are used to assess impacts on the electric power system (in terms of what is displaced that otherwise would have been operated).

Because there are so many details and assumptions involved in estimating savings and creating alternative policies, a state must choose the right approach for the decision process at hand. As described below, the level of available resources (including budget, personnel, and data) often guides which approach to select when developing an energy savings estimate. For a quick comparison of policy alternatives, a top-down approach may be acceptable, while a bottom-up approach may be more appropriate for program planning and budget setting.

Each step is described below.

2.2.1 STEP 1: DEVELOP A BUSINESS-AS-USUAL ENERGY FORECAST

An energy baseline and BAU forecast documents the historical, current, and projected pattern of energy supply and demand within a state. The BAU forecast illustrates what state energy use will look like in the future, in the absence of additional policies beyond those already in place and planned. It typically includes current programs, such as regulations, standards, or energy efficiency programs. The BAU forecast is a reference case

against which to measure the energy impacts of policy initiatives or unexpected system shocks (e.g., severe weather-related disruptions in energy supply).

As presented in Figure 2.2.2, the following six broad steps are involved in developing a BAU energy forecast:

1. Define objectives and parameters;
2. Develop a historical energy baseline;
3. Choose method to develop the forecast or project the historical energy baseline into the future;
4. Determine assumptions and review data;
5. Apply the chosen model or approach; and
6. Evaluate forecast output.

These six steps are described below.

STEP 1.1: Define Objectives and Parameters

For this chapter's purposes, the objective of the BAU forecast is to aid in determining energy savings from clean energy initiatives by offering a current and projected energy picture. To this end, states should:

- Determine if the forecast will be short- or long-term, and end-use based or sector-wide (i.e., explicitly modeling the building stock and end-use equipment vs. using a top-down model of the total sectoral or economy-wide demand);
- Establish the level of rigor necessary;
- Consider the availability of financial, labor, and time resources to complete the forecast; and
- Verify the amount of energy data readily available to develop the forecast.

These factors will help states choose between basic and more sophisticated forecasting approaches.

STEP 1.2: Develop a Historical Baseline

A comprehensive energy baseline includes the following historical energy data:

- Consumption (demand) by sector or fuel, and
- Energy generation (supply) by fuel and/or technology.

Consumption data are often broken down by the sectors that consume the fuels, including the commercial, residential, industrial, transportation, and utility sectors. This type of top-down baseline helps a state understand the large and small consumers within a state and helps target sectors for policy interventions. Each sector can also be further disaggregated to show the types of consumption within.

A top-down approach would be appropriate if a state plans to evaluate or quantify the requirements of a broad, state-wide energy efficiency or renewable energy goal. For example, in 2006, Wisconsin Governor Jim Doyle launched the *Declaration of Energy Independence*, which included a goal of using renewable energy to generate 25 percent of the state’s electricity and 25 percent of its transportation fuels by 2025 (the “25x25” goal). Figure 2.2.3 illustrates a demand baseline by sector that the Wisconsin Office of Energy Independence developed to help it understand implications for energy consumption as it strives to achieve its goal. This top-down baseline helped the state understand how its total energy consumption (i.e., electricity, natural gas, petroleum, coal, and renewable energy use) is spread across sectors and identify which sectors seem most appropriate for further investigation and potential program intervention (Wisconsin, 2007).

An alternative or a complement to the top-down approach is to develop a bottom-up baseline. A bottom-up baseline is very data-intensive, but provides more information about activities within a particular sector than an aggregated, top-down baseline that is used to reveal trends and opportunities across sectors.

The bottom-up approach is most appropriate if a state is exploring a sector- or technology-specific clean energy policy. For example, if Wisconsin targets the residential sector to help achieve its 25x25 goal, the state could develop a bottom-up baseline that depicts the amount of residential consumption attributed to hot water heating, appliances, and cooling. If it finds that the majority of residential consumption is related to specific end-use equipment, it might focus its program design efforts on the most cost-effective and efficacious opportunities for equipment within the residential sector.

It is important to recognize that both past and future demand for energy are products of the economic and weather conditions of the state as well as the types and

FIGURE 2.2.2 SAMPLE FRAMEWORK FOR DEVELOPING AN ENERGY FORECAST

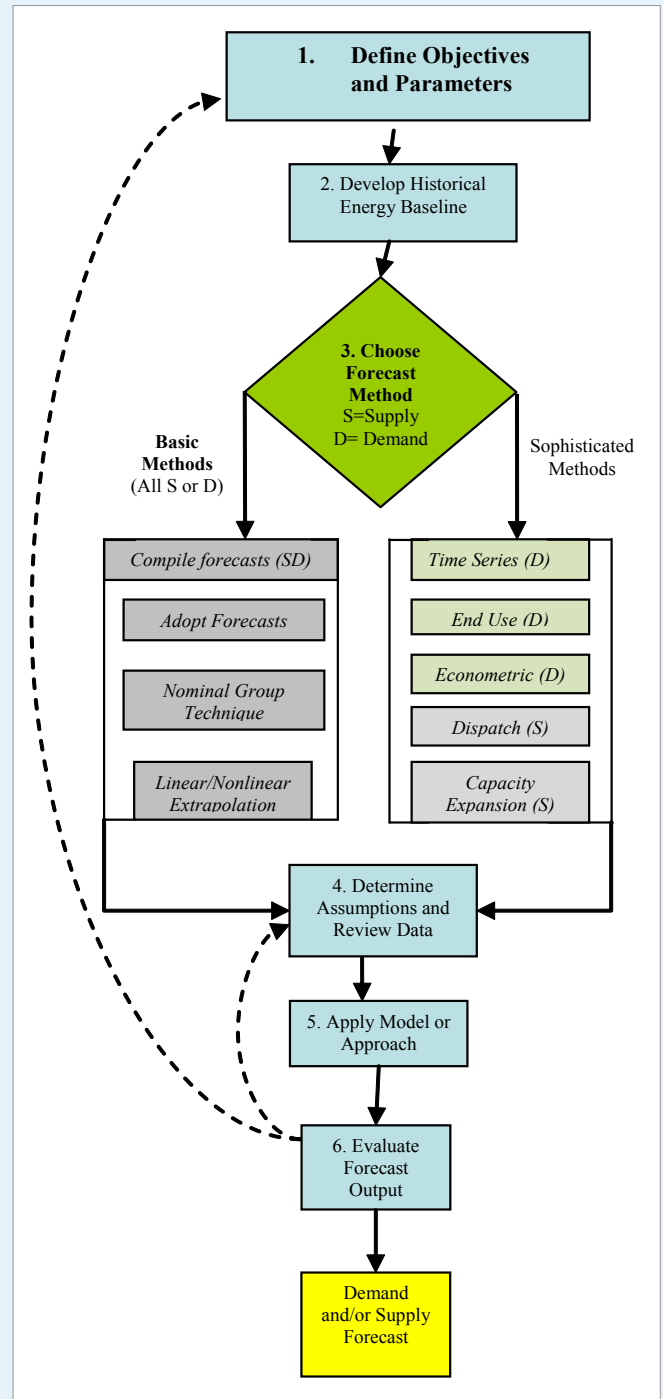

efficiencies of end-use appliances and equipment. Thus, future forecasts often need a specific economic projection as a starting point and should assume normal weather conditions.

FIGURE 2.2.3 WISCONSIN RESOURCE ENERGY CONSUMPTION BY ECONOMIC SECTOR

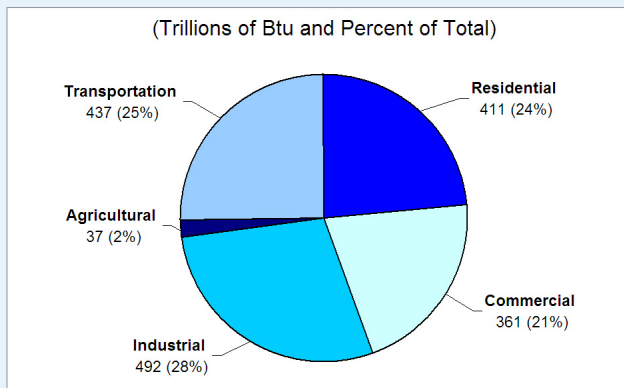

Source: 2007 Wisconsin Energy Statistics, Wisconsin Office of Energy Independence, Achieving 25x25, page 8.

FIGURE 2.2.4 WISCONSIN ELECTRIC UTILITY GENERATING CAPACITY BY TYPE OF PLANT, 2005

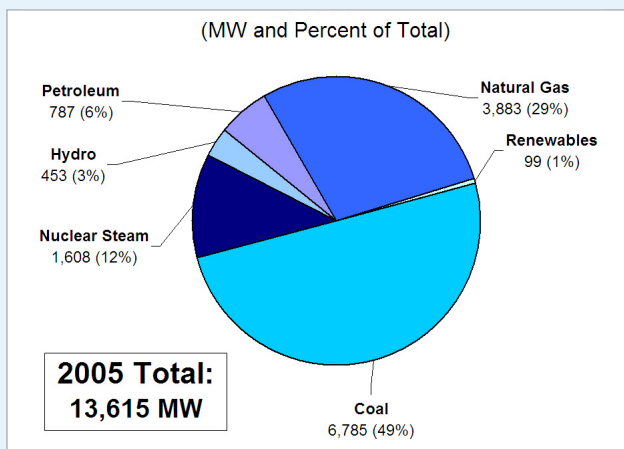

Source: 2007 Wisconsin Energy Statistics, Wisconsin Office of Energy Independence, Achieving 25x25, page 52.

FIGURE 2.2.5 WISCONSIN RESOURCE ENERGY CONSUMPTION, BY TYPE OF FUEL, 2006

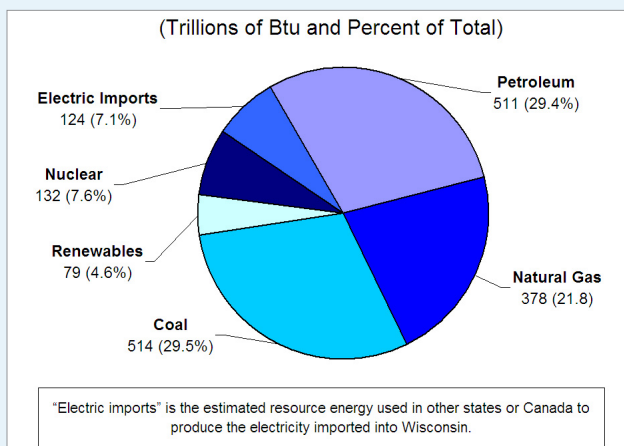

Source: 2007 Wisconsin Energy Statistics, Wisconsin Office of Energy Independence, Achieving 25x25, page 6.

On the **supply side**, electricity generation data can also be categorized by fuel type and sector.⁵ Figure 2.2.4 illustrates Wisconsin’s supply side baseline that shows electricity generation by type of fuel for a single year. A baseline energy forecast requires data about the types and amounts of fuel used to generate electricity, including uranium; coal; natural gas; municipal solid waste; wood; landfill gas; hydro; and petroleum fuels, such as distillates and residuals. Depending on a state’s definition of “renewable,” renewable fuels can include wood, landfill gas, pyrolysis liquid/gas, geothermal, hydro, solar PV/thermal, wind, and municipal solid waste.

Electricity generation data typically include electricity generation that has occurred within the state and, in order to be consistent with in-state consumption, it may reflect electricity imports and exports. It also accounts for transmission and distribution losses.

Consumption and/or generation-related baseline data can be obtained from many sources, including:

- State energy offices and departments of transportation (Figure 2.2.5 provides an example of energy consumption by fuel type data collected by the state of Wisconsin Office of Energy Independence),
- Consumer energy use profiles by sector,
- Utility Integrated Resource Planning (IRP) filings,
- Public utility commissions,
- Independent system operators (ISOs),
- North American Electric Reliability Corporation (NERC),
- EPA’s Emissions & Generation Resource Integrated Database (eGRID) ,
- DOE’s Energy Information Administration (EIA), and
- DOE’s National Renewable Energy Laboratory (NREL).

As shown in Table 2.2.1, these sources provide a variety of different types of data, including historical and projected supply and demand for electricity, natural gas, and other fuels (discussed in the next section).

⁵ Local energy baselines can focus on end-use sectors (i.e., residential, commercial, industrial, and transportation) and allocate the fuel used to generate electricity across the sectors that consumed the electricity.

STEP 1.3: Review and Select Method to Forecast the Business-as-Usual Case

States can use basic or sophisticated modeling approaches to forecast their business-as-usual energy cases and predict energy supply and demand. Both approaches are based on expectations of future population changes, energy data, and economics.

Basic methods may require a state to (1) adopt assumptions made by utilities, independent system operators,

and regulatory agencies about the projected population, energy situation, and the economy; or (2) compile and develop its own assumptions. Basic approaches are generally appropriate when conducting screening analyses or developing highly aggregated forecasts when the amount of time or funding to support a forecast is limited or when the time period of the forecast is short.

More sophisticated methods can be used for short-term or long-term analyses. They provide greater detail

TABLE 2.2.1 SAMPLE ENERGY DATA SOURCES FOR DEVELOPING BASELINES AND BAU FORECASTS

Sources	Electric		Natural Gas		Other Fuels		Description
	Historic	Forecast	Historic	Forecast	Historic	Forecast	
State Sources							
Consumer energy profiles (residential, commercial, industrial)	X		X		X		Most utilities conduct audits, surveys, or EE evaluation studies as part of energy efficiency programs' regular reporting. Data are customer-specific load profiles that can be used to build up total demand.
State Energy, Utility Commissions, Transportation, or other Offices	X	X	X	X	X	X	Most states collect historical and forecast data for both supply and demand information. Other agencies may have compiled similar energy information that could be used for this effort.
Utility-Related Sources							
Utilities	X	X	X	X	X	X	Most utilities collect historical and forecast data. Make sure documentation is collected as well, so that limitations can be understood—what's in and what's not, for example.
Consumer energy profiles (residential, commercial, industrial)	X		X		X		Most utilities conduct audits or EE evaluation studies as part of energy efficiency programs' regular reporting. Data are customer-specific load profiles that can be used to build up total demand.
Public Utility Commissions	X	X	X	X	X	X	Most PUCs collect historical and forecast data. Usually are supplied from utilities and studies. Use to collect supply and demand data.
Independent System Operators/ RTOs	X	X					Supply and total demand information to be used for planning purposes. Available from the Midwest Independent System Operator (ISO), ISO-New England, Pennsylvania-New Jersey Maryland Interconnection, Southwest Power Pool, California ISO, Electric Reliability Council of Texas, Florida Reliability Coordinating Council, and New York Independent System Operator.
North American Electric Reliability Corporation (NERC) Electricity Supply and Demand Database	X	X					Capacity and demand, up to 10-year projections of electricity demand, electric generating capacity, and transmission line mileage. Generation data include unit-level statistics on existing generators, planned generator additions and retirements, and proposed equipment modifications. Free to government agencies. http://www.nerc.com/page.php?cid=4 38

TABLE 2.2.1 SAMPLE ENERGY DATA SOURCES FOR DEVELOPING BASELINES AND BAU FORECAST (cont.)

Sources	Electric		Natural Gas		Other Fuels		Description
	Historic	Forecast	Historic	Forecast	Historic	Forecast	
Federal Agency Sources							
EIA Electric Power Annual	X						National, some regional and state level capacity and demand, margin, energy retail sales (MWh), revenue, emissions, short term plans, etc. http://www.eia.doe.gov/cneaf/electricity/epa/epa_sprdshts.html
EIA State Energy Profile, State Energy Data (SEDS)	X		X		X		Annual production, consumption, prices, and expenditures by energy source. http://tonto.eia.doe.gov/state/ http://www.eia.doe.gov/cneaf/electricity/epm/table1_6_a.html http://www.eia.doe.gov/emeu/states/_seds.html
EIA Electric Sales, Revenue, and Price tables or EIA Annual Electric Utility data—EIA-860, 906, 861 data file	X						Annual data, peak, generation, demand/consumption, revenues, utility type, and state. http://www.eia.doe.gov/cneaf/electricity/epa/epa_sum.html http://www.eia.doe.gov/cneaf/electricity/page/eia861.html http://www.eia.doe.gov/cneaf/electricity/page/eia906_920.html
EIA Manufacturing Energy Consumption Survey (MECS); Commercial (CBECS); Residential (RECS)	X		X		X		A national sample survey on the stock of U.S. buildings, their energy-related building characteristics, consumption (by appliance) and expenditures. http://www.eia.doe.gov/emeu/mecs/contents.html http://www.eia.doe.gov/emeu/cbeecs/ http://www.eia.doe.gov/emeu/recs/contents.html
EIA Annual Energy Outlook	X	X	X	X	X	X	National forecast of supply and demand. http://www.eia.doe.gov/oiaf/aeo/
EPA Emissions & Generation Resource Integrated Database (eGRID)	X						http://www.epa.gov/egrid for supply planning.
NREL	X		X	X	X	X	Data on various renewable energy technologies and some costs. http://www.nrel.gov/rredc/

than the basic methods, and can capture the complex interactions within the electricity and/or energy system. Some states might want to consider a more sophisticated modeling approach for their demand and supply forecasts in cases where:

- They want to better understand the effects of demand growth on their required portfolio of supply resources in the future, or

- They want to analyze the effects on energy demand and supply of significant changes that have occurred or are expected to occur in economic patterns (e.g., a dramatic decrease in housing starts) or energy costs.

Sophisticated approaches are often data-, time-, and labor-intensive; lack transparency; may involve model licensing and data fees; and require a significant commitment of staff resources to develop expertise in the

TABLE 2.2.2 COMPARISON OF BASIC METHODS FOR FORECASTING ENERGY DEMAND AND SUPPLY

Methods	Advantages	Disadvantages	When to use
<i>Compilation of individual forecasts by others</i>	Easy to gather	Driven by different assumptions that may no longer apply; proprietary concerns; possible short horizons; may or may not provide information on construction requirements, fuel use, emissions, and costs; gaps in coverage.	High level, preliminary and quick analysis.
<i>Adoption of a complete forecast used by others</i>	Easiest method	May not have the long-term outlook. Assumptions may not comport with desired state/ regional outlook. May require translation to alternative geographic scope. May be proprietary.	High level, preliminary and quick analysis.
<i>Nominal Group Techniques (NGT)</i>	Consensus building	Time-consuming and relatively expensive.	Adequate budget and stakeholder interest.
<i>Linear and/ or Nonlinear Extrapolation of Baseline</i>	Quick	May not capture impact of significant changes (e.g., plant retirements).	High level with simple escalation factors from history or from other sources.
	More robust data analysis	Possible errors in formulas, inaccurate representation of demand and supply.	Knowledge of generation dispatch by type of plant.

model. Unless the tool is used for broader or multiple analyses (e.g., statewide energy planning), it may be impractical for the state to build the capacity to run these models in-house. However, most models are supported by one or more consultants who have readily available supporting data and who may be retained for these types of specialized studies.

This section provides information about basic and sophisticated approaches, methods under each approach, data needs, and the respective advantages and disadvantages of each of the methods.

Basic Forecast Methods: Demand and Supply

States can use a range of basic methods to project their BAU energy without using rigorous, complicated analyses and software models. These methods generally produce aggregate information about a state’s energy future, perhaps with a larger margin of error than more sophisticated approaches.

Basic approaches for forecasting energy demand and supply include: (1) compilation of partial forecasts (e.g., utility service territory) by others into one state

forecast; (2) adoption of a pre-existing forecast that someone else may have developed for the state; (3) group consensus-building processes to develop assumptions used within a forecast; and (4) extrapolation of historical rates of demand growth and electricity production (or rates of growth from other forecasts) that are applied to the baseline. Table 2.2.2 summarizes the advantages and disadvantages of each approach and describes the most appropriate uses of these approaches. Each approach is explained in greater detail below.

- *Compilation of individual forecasts by others:* Energy plans from utilities, ISOs, and regulatory agencies often include a demand forecast that reflects energy savings from energy efficiency programs. Similarly, a corresponding supply plan is likely to include data on existing and projected renewable energy sources, including combined heat and power plants, if significant. States can aggregate individual load forecasts, generation expansion plans, and energy efficiency programs and renewable energy evaluations from state agencies, utilities, ISOs, local educational institutions, and special interest groups, such as interveners in rate cases. Compiling forecasts created by different entities can be

challenging, because they can vary significantly from each other in terms of underlying assumptions, proprietary concerns, data transparency (e.g., unit generation, costs), and time frame.

- *Adoption of a forecast used by others:* In some states, an energy office, utility commission, revenue department, or academic organization may have prepared a suitable energy forecast. Also, utilities and ISOs may have forecast plans. A regulatory filing requirement (e.g., Integrated Resource Plan) typically provides a comprehensive long-term plan that includes impacts from energy efficiency; reliable demand response, if any; and existing renewable energy plans.⁶ However, there may be proprietary constraints to obtaining this information and these forecasts may reflect economic conditions that differ from the state’s view.
- *Nominal Group Techniques (NGTs)* are structured group processes (similar to “voting”) to form consensus opinions, including expectations for the future. They can be used to develop forecasts or to develop inputs to the preceding methods or more complex models. The type most commonly used in forecasting is the Delphi method. A more recent approach, called Deliberative Polling, might be useful for this purpose, but it is expensive and time-consuming. Working with multiple stakeholders does provide value overall; however, this approach loses detail when valuing the impacts of changes.⁷
- *Linear/Non Linear Extrapolation* involves spreadsheet analysis where historical demand growth rates and electricity production trends (or trends from an alternative forecast) are used to extrapolate base year data into the future. The accuracy of this approach depends on the accuracy of the “borrowed” growth rates, and the knowledge and experience of the analyst when applying historical trends. An advantage to this approach is that it is easy to develop in a spreadsheet and use for preliminary forecasting. A disadvantage is that the exclusion of important variables beyond demand growth factors and electricity—such as weather; season; plant retirements or construction,

FIGURE 2.2.6 NEW JERSEY ENERGY PLAN-BASIC DEMAND FORECAST

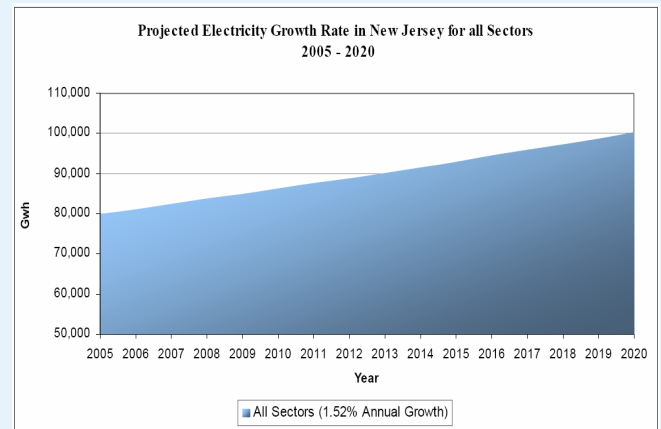

This BAU electricity forecast was developed using a relatively simple approach in which past load growth rates were reviewed and assumptions were made regarding the ways in which industry trends and existing policies affect future growth patterns. While recent growth rates (1998 to 2004) had been in the range of 2% annually, the average annual growth rate since 1990 was only 1.52%. The New Jersey Board of Public utilities chose to carry forward the long term 1.52% growth rate based on the assumption that demand growth would level out once electricity prices increase after the deregulation rate caps expire.

Source: New Jersey, 2008.

operation, or capital costs; emissions; or macro-economic growth—may result in an inaccurate forecast. Figure 2.2.6 illustrates a simple example of a linear extrapolation analysis.

Sophisticated Forecast Methods

States may develop supply and demand forecasts using one of the basic approaches described above, based on the perception that the demand rate will probably follow historical trends. Alternatively, they might want to consider a more sophisticated modeling approach when they require a more comprehensive understanding of their energy profile or when they have experienced or expect to experience significant changes in their energy or economic patterns.

Sophisticated methods involve data- and resource-intensive computer-based models that generate detailed forecasts that may reflect historical trends, economic and/or engineering relationships, future expectations about prices, technologies and technology development, operating constraints, and regulatory

⁶ For information about how utilities integrate energy efficiency into resource planning, see *The Guide to Resource Planning with Energy Efficiency: A Resource of the National Action Plan for Energy Efficiency*, November 2007. www.epa.gov/cleanenergy/documents/resource_planning.pdf

⁷ In Vermont, a similar approach was used through a public workshop process in which electric industry stakeholders provided their input on the state’s energy plan.

expectations (e.g., environmental regulations). While basic forecast methods are applied similarly to demand and supply forecasts, sophisticated approaches generate separate demand and supply forecasts that can be integrated once developed. As such, sophisticated methods for developing demand and supply forecasts are described separately below.

Demand Forecast

Once the historical baseline is developed, states can develop an energy demand forecast using time series, end use, or econometric models. These types of models can be used for short- and long-term load forecasting, comprehensive load analysis, modeling, and “day-after” settlement. Each model, and its advantages and disadvantages, is described below.

- **Time-Series Models** are based on the assumption that the data (and the variable being forecast) have a structure or pattern, such as a trend and/or seasonal variation. Future events are forecast based on known past events and patterns. Inputs require an analysis of historical patterns in demand for electricity. This analysis can be a simple look at the aggregate demand and a forecast based on the pattern of this demand, or a breakdown of the demand into customer type (e.g., residential, commercial, industrial) and application of each cyclical pattern over time to develop the total demand forecast.

Advantages of time-series models are:

- › These models are easy and fast to use; and
- › Historical data are widely available by year, fuel, end use, or sector (residential, commercial, and industrial).

Disadvantages of time-series models are:

- › Data may relate to a historical baseline that has undergone major structural changes, such as a switch from heavy manufacturing to high-technology industries, that are unlikely to occur again, thus complicating or invalidating the forecast;
- › It is hard to reflect future structural changes even if they are anticipated; and
- › Time-series models cannot reflect supply-demand-price feedbacks dynamically.

- **End-Use Models** develop the load profiles of each customer type by analyzing the historical consumption of appliances and equipment (including any existing DSM programs) and may use specific surveys from customers about future growth and contraction. This approach can also include an economic forecast that provides gross state product (GSP) and consumer electricity prices.

- › An advantage is that this approach uses a load profile for each customer class being served, providing a reasonable estimate of demand.
- › A disadvantage is that it can require considerable time and cost to collect the data. Users can elect to use project-specific models to help assess building demand estimates.

- **Econometric Models** provide a more complex and robust analysis that uses inputs such as inflation, demographics, gross state product, consumer energy prices, gross/disposable income, housing starts, business starts/failures, birth/death rates, surveys of business expansion plans, historical energy consumption, and other variables for structural changes and economic data. The model output includes data correlations, or relationships, between demand and energy consumption. For example, the output may show that as income increases, energy demand increases. These relationships can be applied in detailed demand and energy consumption forecasting. Econometric methods are sometimes used in combination with end-use methods.

- › An advantage of this method is that it creates a robust demand forecast if driven with a robust economic forecast.
- › A disadvantage is the time and cost required to prepare the inputs and review the results.

- Some examples of these models in use include ENERGY 2020 and EPRI’s suite of tools. ENERGY 2020 is an end-use-econometric energy market model used for forecasting demand and supply across all fuels and sectors. It has been used in Illinois, Massachusetts, and Hawaii for long-term forecasting. EPRI’s suite of bottom-up, end use forecasting models, such as the Residential End Use Energy Planning System (REEPS) and the Commercial End Use Planning System, are used primarily by utilities. Some states have developed their own models. For example, California has developed end use (residential) and econometric (commercial) models for forecasting.

Supply Forecast

Utilities, ISOs, and other sophisticated energy market participants use supply forecast models for hourly, daily, monthly, and long-term forecasting. Sophisticated supply forecasting models require large volumes of data on electricity production plants, transmission capabilities, and a demand forecast—and the better the quality of that data, the better the results. Although the costs to acquire the software and data may be prohibitive for some users, these models generally provide more robust estimates on energy and capacity output than basic modeling approaches. Models covering both electricity dispatch modeling and capacity expansion (or planning) modeling are summarized in Table 2.2.3.

- *Electricity Dispatch models* (also commonly referred to as “production cost” models) simulate the dynamic operation of the electric system, generally on a least-cost system dispatch. In general, these models optimize the dispatch of the system based on the variable costs of each resource and any operational constraints that have been entered into the model. These models are helpful in assessing which existing plants⁸ are displaced. These models

⁸ These dispatch, or production costing models focus on existing plants or a specified portfolio of plants (which may contain some new or proposed plants); however, these models only produce estimates of avoided variable costs and changes in the output of different resources. Changes in the use of a resource (e.g., a marginal coal-fired power plant) are key inputs into any modeling of changes in emissions due to EE or RE activities. These dispatch models do not internally examine changes in the capital costs (e.g., avoided capital costs) that might result from investments in EE or RE. However, this can be done through spreadsheet models that have been developed to augment electricity dispatch models or using models that combine capacity expansion and dispatch (e.g., NEMS, IPM).

TABLE 2.2.3 EXAMPLES OF SOPHISTICATED SUPPLY FORECASTING MODELS

Sampling of models	Advantages	Disadvantages	When to Use this Method
Electricity Dispatch			
<ul style="list-style-type: none"> ▪ PROSYM™ ▪ GE MAPS™ ▪ PROMOD IV® ▪ MIDAS^a 	<ul style="list-style-type: none"> ▪ Can provide very detailed estimates of specific plant and plant-type effects within the electric sector. ▪ Provides highly detailed, geographically specific, hourly data. 	<ul style="list-style-type: none"> ▪ Often lacks transparency. ▪ Labor- and time- intensive. ▪ Often high labor and software licensing costs. ▪ Requires establishment of specific operational profile of the clean energy resource. 	<ul style="list-style-type: none"> ▪ Often used for evaluating: <ul style="list-style-type: none"> ▪ Specific projects in small geographic areas, ▪ Short-term planning (0-5 years), and ▪ Regulatory proceedings.
Capacity Expansion or Planning			
<ul style="list-style-type: none"> ▪ NEMS ▪ IPM® ▪ ENERGY 2020 ▪ LEAP ▪ Strategist® ▪ Plexos® ▪ EGEAS ▪ AURORAxmp ▪ MARKAL-MACRO^b ▪ Ventyx System Optimizer 	<ul style="list-style-type: none"> ▪ Model selects optimal changes to the resource mix based on energy system infrastructure. ▪ May capture the complex interactions and feedbacks that occur among demand, environmental, fuel, electric markets. ▪ Provides estimates of emission reductions from changes to the electricity production and/or capacity mix. ▪ May provide unit-specific detail (IPM). 	<ul style="list-style-type: none"> ▪ Requires assumptions that have large impact on outputs. ▪ May require significant technical experience. ▪ Often lacks transparency. ▪ Labor- and time- intensive. ▪ Often high labor and software licensing costs. 	<ul style="list-style-type: none"> ▪ Long-term studies (5-25 years) over large geographical areas. such as: <ul style="list-style-type: none"> ▪ State Implementation Plans, ▪ Late-stage resource planning, ▪ Statewide energy plans, and ▪ Greenhouse gas mitigation plans.

^a Ventyx markets the MIDAS solution as a strategic planning tool since it incorporates Monte Carlo capabilities. This tool is included in the list of electricity dispatch models, as it generally uses a pre-selected set of resource plans and the MIDAS model focuses on electricity price forecasting and financial analyses (e.g., balance sheet analyses) of each resource plan.

^b MARKAL-MACRO model is represented as multipurpose energy planning model, <http://www.etsap.org/Tools/MARKAL.htm>.

are also used in short-term planning and regulatory support.

Advantages of electricity dispatch models are:

- ▶ These models are often used in generation project financial analyses, since they provide forecasts of wholesale electric prices for each hour (i.e., system marginal costs) and the hourly operations of each unit. By comparing the variable costs of each unit with the price forecasts, an estimate of plant profitability can be developed.
- ▶ They can be run to develop a BAU and multiple sensitivity cases to assess the impact on various planning parameters (e.g., transmission, plant dispatch, and avoided variable costs), and may capture complex interactions and tradeoffs.
- ▶ Electricity dispatch models are usually more detailed in their specification of operational and variable costs compared with capacity expansion models.
- ▶ These models are ideally suited for estimating wholesale electric prices (i.e., the marginal system cost) and the hours of operation and production of each unit in the system for up to a five-year time frame. This information has been the basis for plant financing decisions and the development of unit operating and bid strategies in markets. In these roles, the electricity dispatch model is viewed as a superior tool. These same data also are necessary in estimating the emissions of specific units and the regional electric system being modeled.

Disadvantages of electricity dispatch models are:

- ▶ These models cannot estimate avoided capacity costs from EE or RE investments. Unlike the capacity expansion models described below, these costs must be calculated outside the electricity dispatch model using a spreadsheet model or other calculations.
- ▶ Some of these models require substantial detail on each unit in a regional electric system and are typically full chronologic models (i.e., some data elements are needed for all 8,760 hours in a year).

- ▶ The complexity of these models often results in agencies and stakeholders working with utilities to coordinate the application of the models in policy analyses and in regulatory proceedings.
- ▶ Electricity dispatch models can also be effectively used to develop estimates of generation impacts of long-term resource plans, but they require considerable side calculations in terms of the explicit specification of projected new units that constitute a limited number of “build scenarios” and the computation of the capital costs of the system to augment the variable costs produced internally by the electricity dispatch models.

- *Capacity Expansion or Planning models* are designed to make decisions on how the electric system adds new capacity to meet future demand over a 20- to 25-year planning period. This differs from the primary role of electricity dispatch models, which is to develop electricity price forecasts, the hours of operation, the electricity output for specific units, and the revenues and profits for generation units in a regional system. In contrast, capacity expansion models evaluate the economics of potential new generating unit additions to the system (some models allowing a great deal of specificity with respect to new unit options). Capacity expansion models use information on demand growth, regional electric system operations, and the characteristics of candidate new units, typically within an optimization framework, that selects a future build-out of the system (multiple new units over a 20- to 25-year time frame) that has the lowest overall net present value (NPV), taking into account both capacity and variable costs of each unit. This simulated build-out can include the retirement of existing units, selection of base load capacity, and decisions to build peaking capacity that minimizes the NPV over the 20- to 25-year planning scenario.

Many capacity expansion models have some representation of system dispatch. Dispatch modeling in these combined capacity expansion and dispatch models may not be based on an 8,760 hourly structure, but instead dispatch to more aggregated load segment curves representing seasonal energy demand by load segments (e.g., peak, intermediate segments, and base load). These types of models include IPM® and NEMS.

Advantages of capacity expansion models are:

- ▶ They are designed to incorporate a number of factors that are influenced by changing policies, regulatory regimes, or market dynamics (e.g., stricter emission policy, introduction of a renewable portfolio standard).
- ▶ While both electricity dispatch models and capacity expansion models are used in IRP proceedings, the capacity planning model is designed specifically to develop long-term resource plans.
- ▶ Capacity expansion models are able to estimate avoided capacity costs and usually also produce estimates of avoided variable costs.

Disadvantages of capacity expansion models are:

- ▶ The complexity of these models often results in agencies and stakeholders working with utilities to coordinate the application of these models in policy analyses and in regulatory proceedings.

STEP 1.4: Determine Assumptions and Review Data

After choosing the forecasting approach or model type, the next step is to determine or review assumptions about population, energy, and economic variables, such as energy prices, productivity, gross state product, and the labor force upon which projections of energy demand and supply depend.

It is also important to review possible data sources and collect the data required for the analysis. The following types of data are used in estimating energy consumption and supply baselines and forecasts:

- States can use **population data** to estimate the amount and types of demand expected in the future and to examine trends. The U.S. Census Population Estimates Program provides historical and projected population data (<http://www.census.gov/popest/estimates.php>).
- A forecast depends upon assumptions about the economy that the analyst projects into the future. States can examine **economic variables** as they relate to energy in order to better understand the historical relationships between energy and the economy, and to anticipate how these relationships

may exist in the future. The Bureau of Economic Analysis (<http://www.bea.gov/>), Bureau of Labor and Statistics (<http://www.bls.gov/>), and the U.S. Census Economic Census (<http://www.census.gov/econ/census02/>) all provide macroeconomic data that states can use.

- The forecast may require assumptions about the **energy and fuel prices** the state should expect in the future. EIA provides regional energy and fuel price forecasts out to 2030 (<http://www.eia.doe.gov/oiaf/forecasting.html>). Price projections may also be available from PUCs and ISOs, although proprietary constraints may limit the amount available. In addition, a number of private data providers may be able to offer data that are more recent than those from publicly available sources.

Almost all providers of electricity dispatch and capacity expansion models also offer a data set that can be used to apply these models to a regional electric system. Data from any source must be examined to ensure that they are consistent with the assumptions of the entities that will use the model results, and to check for outliers, errors, and inconsistencies in the data. No data set from any source is guaranteed to be fully appropriate to a user's needs, and any data set may contain errors.

At this point in the process, it may also be necessary to clean the data and/or fill in any missing data gaps. If data points are missing for particular years, it may be necessary to interpolate the existing data or use judgment to fill in gaps. This will minimize the likelihood of generating results based on calculations that are skewed due to missing or out-of-range data, producing a forecast that would then not make sense. Some of the private data providers also provide data cleaning services. Practical application of any of these data bases, however, requires due diligence in looking for data outliers, missing values, and screening for errors in data. It is a rare occurrence for a user to obtain a fully clean data set, consistent with their individual assumptions, from any one source.

STEP 1.5: Apply Model or Approach

States can apply the selected model or approach to the historical baseline energy data based on the assumptions about future population, economic, and energy expectations. It is important to revisit the assumptions and data that will be required for the specific model requirements to assure that they are still valid. As mentioned in earlier sections, many state agencies and stakeholders work with utilities or consultants to actually perform

the model runs. Still, it is important to have transparency around the model inputs and the policy/regulatory assumptions incorporated into the model, as well as a solid understanding of the basic operations of the model (i.e., the algorithms used to produce the model outputs).

STEP 1.6: Evaluate Forecast Output

Once generated, it is important to evaluate the forecast to ensure that it is reasonable and meets the original objectives. If the state determines that some or the entire forecast does not seem realistic, it may need to revisit assumptions and then re-apply the approach or model to achieve an acceptable demand forecast.

Issues and Considerations

When developing an energy baseline and BAU forecast, it is important to consider the following issues.

- Typically the data available for a baseline and BAU forecast lag several years. For this reason, the current and most recent years may be part of the forecast and not the history. It is important, therefore, to ensure that the data derived for recent years reflect the current energy supply and demand as much as possible.
- As with all analyses, transparency increases credibility. All sources and assumptions require documentation.
- When documenting an energy forecast, it is important to clearly state what activities will take place without any new clean energy initiatives (i.e. what is “in the baseline”). For example, many state forecasts assume that some level of energy-efficient actions or regulatory changes (e.g., GHG reduction requirements) will be implemented over time. It is important to avoid double-counting when examining future program potential or impacts.

2.2.2 STEP 2: QUANTIFY IMPLICATIONS OF TARGETS AND GOALS

If a state has or is considering a broad clean energy goal, it is helpful to estimate the potential implications of the goal before evaluating specific clean energy programs and implementation options. For example, the state may need to quantify—in terms of kWhs—the requirements of an energy efficiency goal or target. Suppose the policy or goal is to have zero growth in energy demand over the next 10-20 years; it would then be necessary to estimate how much energy efficiency

would be required to meet that goal. Alternatively, the state may need to quantify—again, in kWh terms—the implications of a renewable portfolio standard. These estimates will indicate how much energy must be saved each year, or how much clean energy must be provided.

While the energy implications of any goals should be checked against existing energy efficiency or renewable energy potential studies to make sure they are plausible, this type of estimate is not focused on estimating what is cost-effective, what the market might adopt, or when the specific technologies might be adopted; it only estimates what the goal or target implies.

Methods for these estimates can include both basic and sophisticated approaches, but these high-level estimates will most likely require only the most basic approaches as the focus is simply on quantifying the meaning of the goal (e.g., a 2 percent reduction in demand per year implies a savings of x kWh). Basic approaches typically start with a baseline forecast as developed under Step 1. This will be the primary determinant of energy savings or clean energy supply required. The exact methodology chosen, however, will depend on how the goal or target is specified and a host of other factors, such as whether the energy savings from efficiency are measured from the baseline forecast or from prior years' sales. Also, the extent to which existing programs do or do not count toward the target may affect the calculations. It is important to read (to the extent they are available) the details of the goal, policy, or legislation, then think through the implications of these details for the methodology and calculations.

Suppose a state is determining the anticipated energy savings or generation needed to achieve a clean energy initiative in a target year (e.g., the target is to build 100 MW of wind power capacity by 2020). If appropriate financial incentives are in place to encourage construction of the wind facility, the energy available in the year after 100 MW of wind facilities are placed in service can be estimated at a very basic level as:

$$100 \text{ MW} * 0.28 \text{ capacity factor}^9 * 8,760 \text{ hours/year} = 245,280 \text{ MWh/year.}$$

The important element here would be to ensure that the 28 percent capacity factor is applicable to the

⁹ Capacity factor is defined as the ratio of the electrical energy produced by a generating unit for the period of time considered to the electrical energy that could have been produced at continuous full power operation during the same period. Typical capacity factors for wind range from 20 percent to 35 percent.

EXAMPLES OF STATE ENERGY TARGETS OR GOALS

- Have a rate of zero load growth by 2020.
- Reduce electricity demand by 2% per year by 2015, and 2% every year thereafter, with reductions to be based on prior three years' actual sales.
- Meet 20% of generation requirements (or sales) through renewable energy sources by some date in the future (sometimes with interim targets). In some instances, the eligible resource types (including existing), the required mix of renewables types, and geographic source of the renewables may be specified.

wind resource being considered. The output of a wind turbine depends on the turbine's size and the wind's speed through the rotor, but also on the site's average wind speed and how often it blows. Data to assess appropriate capacity factors can be identified based on geographic data on wind class (speed).

Alternatively, suppose a state is considering an Energy Efficiency Portfolio Standard (EEPS) that calls for a 20 percent reduction in energy demand growth by 2020.

The state might estimate the annual implications of the policy as outlined below (with calculations illustrated in Table 2.2.4).

- First, a pathway, with annual targets, would be required to assure the 20 percent total reduction is reached. Table 2.2.4 shows one possible pathway.
- Next, this percent savings is applied to the BAU forecast (which was expected to increase by 3 percent per year prior to the EE initiative) in order to calculate EE savings required. The fourth column shows the EE savings required.
- Finally, the new target level of demand is shown. In this example, the results indicate a new lower demand annual average growth rate (AAGR) of 1.1 percent.

While the actual path that is followed or the estimates of achieved savings (e.g., for M&V purposes) may differ from those shown in this simple exercise, this type of calculation gives an indication of the implications for program requirements and the resulting impact on growth.

TABLE 2.2.4 EXAMPLE OF ESTIMATION OF REQUIRED EE SAVINGS BASED ON LONG TERM SAVINGS GOAL OR PERFORMANCE STANDARD (KWH)

	BAU Demand (3% AAGR)	% Required Savings off of BAU required	EE Savings Required	New Target Demand (New AAGR = 1.1%)
2008	1,000.0	0.5%	5.0	995.0
2009	1,030.0	1.0%	10.3	1,019.7
2010	1,060.9	1.5%	15.9	1,045.0
2011	1,092.7	3.5%	38.2	1,054.5
2012	1,125.5	5.5%	61.9	1,063.6
2013	1,159.3	7.5%	86.9	1,072.3
2014	1,194.1	9.5%	113.4	1,080.6
2015	1,229.9	11.5%	141.4	1,088.4
2016	1,266.8	13.5%	171.0	1,095.8
2017	1,304.8	15.5%	202.2	1,102.5
2018	1,343.9	17.5%	235.2	1,108.7
2019	1,384.2	19.5%	269.9	1,114.3
2020	1,425.8	20.0%	285.2	1,140.6

If the state has an emissions-related goal, this type of quick, top-down analysis can then be linked to emissions data to determine what portion of the state's emissions targets could be met with a specific percentage EEPS. Similar linkages could be made to economic or other impacts as well.

Considerations

There are a number of factors to consider when estimating the implications of targets and goals for electricity demand and resources:

- The baseline level of electricity demand and supply (described earlier in this chapter);
- Expected growth over time under BAU (described earlier), including any ongoing energy efficiency or renewable energy efforts that may or may not contribute to the new goal, but will influence baseline conditions;
- The likely persistence of energy efficiency savings over time (or changes in the supply of clean energy);
- Other considerations that may affect the level of savings or supply required, such as rebound effects in energy efficiency programs; and
- The remaining electricity demands (or supply) after the impacts occur.

Quantifying the implications of broad goals and targets typically requires straightforward mathematical calculations, as shown above, and do not usually involve sophisticated approaches. However, advanced modeling and economic analysis may be required if, for example, a goal or target is tied in some way to an economic indicator or requirement (e.g., if a goal or target has some circuit-breaker or threshold provision, for example, requiring that only energy efficiency costing less than a certain amount be required), or has some dynamic aspects to it (e.g., changing targets in response to achievements).

2.2.3 STEP 3: ESTIMATE POTENTIAL DIRECT ENERGY IMPACTS

A critical step in the process of assessing the multiple benefits of clean energy is the estimation of the potential direct energy impacts of clean energy programs or policies under consideration. Direct energy impacts include energy savings from energy efficiency initiatives

PROGRAMS FOR WHICH ENERGY IMPACTS MIGHT BE ESTIMATED

- Energy Efficiency Portfolio Standards
- Renewable Portfolio Standards
- Appliance Standards
- Building Codes
- Public benefits funds (to fund state or utility-run efficiency or renewables)
- Clean Energy Tax or other Financial Incentives
- Rebate programs
- Lead by Example Programs

and electricity production from renewables and other clean energy supply options. These estimates are the foundation for estimating the multiple benefits of clean energy as described in the subsequent chapters of this *Resource*. For example, changes in energy consumption due to energy efficiency or energy output from clean resources are matched to characteristics of generation, as described in Chapters 3 and 4, to assess changes in costs, emissions, and other factors.

Potential direct energy impact estimates can be developed in the context of a target, but a target is not required to estimate these impacts. Here the state would be estimating the expected result of a policy or program that is under consideration and has been sufficiently defined to allow meaningful analysis. In the case of prospective programs and policies, the state is trying to assess whether the program or policy goals are achievable and at what costs, and what specific actions are required by market participants. For example, the state may be considering an RPS of 20 percent by the year 2020, and wants to understand what specific resources would have to be built to comply; or the state may have a goal of 10 percent reduction in residential energy demand in five years and wants to understand what programs it can implement to achieve that goal.

Examples of these types of impact estimates include:

- Estimating the impact of appliance standards in a way that considers the existing stock, current efficiency levels, and consumer decision making;
- Estimating the expected response to a utility energy efficiency program, with or without specific information on program focus (what sectors and end uses) and design issues (e.g., rebate levels); and

- Estimating the impact of a renewables incentive program.

Please see the text box *Programs For Which Energy Impacts Might Be Estimated* for program examples.

Similar to the process for developing an energy forecast, estimating the potential direct energy impacts involves a series of steps, including:

1. Define Objectives and Parameters,
2. Choose Method to Estimate Potential Direct Energy Impacts,
3. Determine Assumptions and Review Available Data,
4. Apply Model or Approach, and
5. Evaluate Output.

Each of the steps is described in greater detail below.

STEP 3.1: Define Objectives and Parameters

It is important to define the objectives and parameters of the direct energy impacts a state plans to estimate. If the objective is to quantify the required energy savings from a state's clean energy initiatives or goals to the state legislature, for example, the parameters of the analysis may already be dictated. For example, the legislature has likely specified a due date, a time period to be analyzed, and a reasonable level of rigor, and may even have required the state to spend a certain amount of money on the analysis. Other analyses, such as those conducted to screen a range of clean energy options based on their multiple benefits, may be less defined.

It is necessary to consider each of the following parameters before choosing an analysis method, model, or dataset(s) to use.

- *Time period for the direct energy impacts:* Is it a short-term or longer-term projection?
- *Timeliness of the estimates:* Is this due in a year or next week?
- *Level of rigor necessary to analyze policy impacts:* Is this for a screening study or a regulatory analysis that is likely to be heavily scrutinized?

- *Availability of financial, staff, and outside resources to complete the analysis in the required time period:* Is there a budget available for the analysis? Does the state have internal modeling capabilities?
- *Amount of data available, or that can readily be acquired, to develop the savings estimate:* Are there existing clean energy potential studies or similar projects elsewhere that can be adapted to a state analysis?

These factors will help states choose between simple and more rigorous approaches based upon specific needs and circumstances.

STEP 3.2: Choose Method to Estimate Potential Direct Energy Impacts: Energy Savings and Renewable Energy Generation

Several tools and methods are available to help states estimate the potential direct energy impacts of clean energy options. States can conduct their own surveys or studies to estimate the direct energy impacts of clean energy policies and use sophisticated methods, such as applying building simulation tools, vintaging models, and production costing models. Because new surveys and studies tend to be costly and time-consuming, however, states often use those that have already been done by utilities, trade groups, other states, or the federal government, and adapt them to reflect the circumstances of the state. It is likely that states will need to use a combination of both existing and new analyses, since existing data sources and studies must be supplemented with complete and up-to-date data for specific populations and measures that can be difficult to obtain without additional targeted research.

Estimates typically factor in several considerations, including:

- the characteristics of the customer base and the existing equipment stock,
- the economics of the clean energy options and their alternatives, and
- the behavior of the market.

For example, to understand the generation system impact of renewable energy resources, it is important to understand not only how much renewable energy is required to meet the policy and therefore is coming into the grid, but what type of renewable resource will be available and that resource's operating characteristics

(capacity factor, energy generation profile).¹⁰ States also want to understand the cost and other impacts of the energy efficiency and renewables driven by the clean energy policy or mandates.

These types of questions require methodologies and approaches that consider technology characteristics, economics, and market conditions. For example, estimating energy impacts from energy efficiency requires an understanding of the current penetration of a technology, applicability to new (or existing) homes, customer financial requirements and preferences, penetration patterns, and load shape impacts. Analysis of appliance standards or building codes requires understanding the technologies, but also the system impacts at the building level. In addition states must understand the potential impacts across the entire population of affected buildings. Again, more advanced techniques may be required, such as building simulation tools and market penetration models, but some basic non-modeling methods may apply. The range of approaches is described below.

Approaches

Assessing the potential impacts of energy efficiency or renewable energy programs requires “bottom up” economic and/or engineering-based estimation techniques—building up estimates of impacts based on a representation of the fundamentals of the technology, the economics, and market behavior. These bottom-up approaches involve estimating potential energy savings at a very detailed level and rolling these estimates up to the clean energy or statewide initiative level.

Analyses typically involve basic to sophisticated calculations or spreadsheet analysis, and the collection of data and information about the experiences or analyses of programs within and outside of the state. Depending upon the level of sophistication used in the analysis, the analysis may or may not consider explicitly local economics, transmission requirements, or generation system impacts. The most basic types of analyses (i.e., those that exclude those factors) may be useful only for developing short-term impact estimates, depending on the extent of the comparable historical experience.

Depending upon the level of detail desired and the amount of new analyses needed, estimating the

potential impacts can require an extensive amount of data and, for the more detailed analyses, may be costly.

At a minimum, the analysis will require some level of detail about the:

- *Individual measure savings or renewable energy savings* that can be rolled up into an aggregate estimate or state-wide strategy, and
- *Saturation of energy efficiency or renewable energy equipment* in the market so that the state can determine how much opportunity for new investment is feasible when compared against potential studies.

Individual Measure or Site-level Savings for Generation Estimates

To estimate the potential savings of clean energy measures, states can conduct simple analysis of estimated energy efficiency or renewable energy impacts based on an extrapolation of existing energy efficiency or renewable energy potential studies. These studies may be sector-specific (residential, commercial, industrial), or more aggregated at some geographic level (state or region). They may reflect technical potential, economic potential, or market potential, or all three. If only the first two estimates are provided, the analysis should consider what is achievable.¹¹

States can also explore existing studies of similar programs in other states and adapt the results to their conditions. At the aggregate level this may mean scaling results to the state’s load forecast, perhaps accounting for sectoral share differences if data are available at the sectoral level. For estimates of individual measure impacts or site-level impacts associated with clean energy measures, states can look to available retrospective studies that can be extrapolated into prospective savings based on an understanding of the state’s sectoral and end-use mix. Table 2.2.5 lists resources on retrospective savings estimates and existing potential studies states can use to produce individual savings estimates.

These estimates can be summed across the populations in each sector, remembering to subtract the market penetration levels for the clean energy measures that are already installed (based on the saturation data, as

¹⁰ For information to help a state decide if biomass is a viable renewable energy option to consider and, if so, the most promising options to pursue, see EPA’s State Bioenergy Primer <http://www.epa.gov/statelocalclimate/resources/bioenergy-primer.html>

¹¹ EPA has developed guidance on conducting an energy efficiency potential study. See *Guide for Conducting an Energy Efficiency Potential Study, A Resource of the National Action Plan for Energy Efficiency*, November 2007. http://www.epa.gov/RDEE/documents/potential_guide.pdf

TABLE 2.2.5 RESOURCES FOR CLEAN ENERGY RETROSPECTIVE DATA AND POTENTIAL STUDIES

Resource	Description	Web Site
Market Assessment and Program Evaluation (MAPE) Clearinghouse	Database developed by <i>Consortium for Energy Efficiency</i> (CEE) that contains energy-efficiency program evaluation reports, potential studies, and related documents that are publicly available.	http://www.cee1.org/eval/clearinghouse.php3
<i>Lawrence Berkeley National Laboratory</i> (LBL)	Technical resource that tests and invents energy-efficient technologies and provides publicly available research reports and case studies on EE and RE.	http://www.lbl.gov ; http://eetd.lbl.gov/ea/ems/cases/
<i>Renewable Energy Policy Project</i> (REPA)	Research papers, primarily on RE. Example reports are “Wind Energy For Electric Power” and “Powering the South: A Clean and Affordable Energy Plan for Southern United States,” which includes EE and RE.	http://www.repp.org/repp/
<i>American Council on Energy Efficient Economy</i> (ACEEE)	Consumer resources on appliances, policy, potential study workshops, technical papers.	http://www.aceee.org/
<i>Tellus Institute</i>	High-level reports presenting scenarios on increased efficiency and renewable energy standards, reporting on their impact on the environment. Also provides additional links to the software models used by the Institute, including LEAP (Long-range Energy Planning).	http://www.tellus.org/
<i>National Renewable Energy Laboratory</i> (NREL)	Provides data on RE and EE technology, market, benefits, costs, and other energy information.	http://www.nrel.gov/analysis/
<i>California Database of Energy Efficiency Resources</i> (DEER)	Provides documented estimates of energy and peak demand savings values, costs, and effective useful life. In this California Energy Commission and California Public Utilities Commission sponsored database, data are easy to research and could be used as input into internally developed spreadsheets on appliances and other EE measures, which can be adjusted for the circumstances of different states.	http://www.energy.ca.gov/deer/
<i>Regional Technical Forum</i> (RTF) deemed savings database	Developed by the Northwest Planning Council staff, with input from other members of the regional technical forum, which includes utilities in the four-state region of Oregon, Washington, Idaho, and Montana. Both residential and commercial EE measures are included.	http://www.nwcouncil.org/energy/rtf/supportingdata/default.htm
<i>Entergy Texas Deemed Savings</i>	Entergy, an investor-owned utility (IOU), provides deemed energy savings for EE measures, much as the other IOUs in Texas do. It accounts for the weather zone of the participants. These data could be used as input into internally developed spreadsheet regarding appliances and other EE measures for a bottom-up method. The data may have to be adjusted for a different state.	http://www.energy-texas.com/content/Energy_Efficiency/documents/HelperApplication_HTR_Entergy_2006.xls

described in greater detail below). When implementing this approach of adapting existing studies to evaluate renewable energy options, states should correct for the relative resource base available since states have different levels of renewable energy resources (e.g., wind, solar) available. The results should be adjusted to reflect any difference.

Saturation of Energy Efficiency or Renewable Energy Equipment

It is important to understand how much equipment is already in the market so that states can determine a feasible level of investment that a new clean energy program or policy could induce. The equipment saturation data are typically determined using one or more methods, including:

- *End-use Customer Saturation Surveys.* These surveys provide a relatively cost-effective method of estimating saturation levels for both standard and efficient equipment. These on-site, telephone or Internet surveys are conducted to gather information regarding the end-use equipment currently installed at a statistical sample of homes and businesses.
- *Site Visits.* Facility managers can provide high-quality estimates of equipment saturations. However, due to the tremendous amount of energy consumption represented by large nonresidential facilities, and the limited amount of program audit data available, it is often necessary to conduct primary data collection at a sample of sites that represent the sub-sectors in the population.
- *Survey of Retailers.* Retailers can provide important insight into the market share and saturation of a number of products, including programmable thermostats, water heaters, clothes washers, clothes dryers, and refrigerators.
- *Surveys of Builders and Code Officials, Builders, Architectural and Engineering Firms, and Other Trade Allies.* These data can be also be used to characterize the equipment saturations in the new construction and retrofit markets if samples are carefully selected and appropriate survey instruments developed. Interviews with contractors, dealers, distributors, and other trade allies provide a cost-effective research approach, as business activity tends to be concentrated among relatively few market actors. Trade ally interviews can also be leveraged to assess market share and estimates of market saturation for multiple sectors during a single interview.

Once equipment saturation is understood, states can compare it against potential studies to determine the feasible level of investment opportunity available.

Tools for Direct Savings or Generation Estimates

A number of modeling and analytics tools are available to help states estimate the potential direct energy impacts of clean energy measures. Table 2.2.6 provides examples of some simple analysis tools available when employing non-integrated modeling approaches to estimating energy savings from EE and RE initiatives. The tools shown in the table are organized by web-based, spreadsheet, and software tools. Some of these tools are designed to develop site-level savings estimates that can be aggregated up to the state.

For example, the site-level estimates from tools such as eQuest® (for EE measures) or PVWatts™ (for estimating solar system electricity production) are summed across expected participant populations to get statewide energy savings estimates. Other tools (e.g., DSMore™) are intended to provide program-level rather than site-level estimates of energy savings.

Depending upon the level of detail desired, the tools and methods described above have the ability to produce detailed information about the clean energy technology's patterns of operation. Building simulation models, for example, produce detailed hourly load patterns reflecting when an energy-efficient technology reduces demand for a given building, application, and climate zone. This information is needed to assess the detailed impact on the utility system, specifically what generation technology will be displaced or avoided over the long term. Load shapes for particular technologies can also be acquired from third parties if building simulations are not used.

Analysis of a renewables policy or program would examine the costs and operation of eligible renewable resources and their interaction with the existing (and planned future) generation system. This type of analysis is often more complex, and therefore may require a more sophisticated approach. A sophisticated capacity planning and system dispatch model, for example, would require information on the costs and performance of renewables, as well as energy efficiency options and their penetration potentials. Some of these models have the ability to model energy efficiency and renewable energy explicitly, reflecting potential EE load shape impacts and penetration patterns, and energy generation profiles for renewables. Others treat these non-dispatchable and intermittent resources in simpler ways.

Several sources are available to help predict the load profile of different kinds of renewable energy and energy efficiency projects as listed below.

- Performance data for renewable technologies are available from the National Renewable Energy Laboratory (NREL), as well as universities and other organizations that promote or conduct research on the applications of renewable energy. For example the Massachusetts Institute of Technology's Analysis Group for Regional Energy Alternatives and Laboratory For Energy and the Environment conducted a 2004 report, *Assessment of Emissions Reductions from Photovoltaic Power Systems*

TABLE 2.2.6 EXAMPLES OF AVAILABLE TOOLS FOR ESTIMATING DIRECT ENERGY IMPACTS

Tool Name	Level of Analysis	Description	Source
<i>Internet Based Methods</i>			
eCalc™	New /retrofit buildings Renewable energy sources (e.g., solar heating, solar PV, wind power)	Web-based calculator that enables users to design and evaluate a wide range of clean energy projects for energy savings and emissions reduction potential. In addition to buildings and renewable energy sources, eCalc calculates energy savings for municipal wastewater projects, traffic lights, and street lighting projects.	http://ecalc.tamu.edu/
ENERGY STAR® Savings Calculators	Energy efficiency measures	Series of tools that calculate energy savings and cost savings from ENERGY STAR-qualified equipment. Includes commercial and residential appliances, heating and cooling, lighting, office products, and other equipment.	http://www.energystar.gov/purchasing
ENERGY STAR Roofing Comparison Calculator	Buildings	Estimates energy and cost savings from installing an ENERGY STAR® labeled roof product in a home or building.	http://www.roofcalc.com/default.aspx
ENERGY STAR Target Finder	New buildings	Helps planners, architects, and building owners set aggressive, realistic energy targets and rate a building design’s estimated energy use. Use the tool to determine: <ul style="list-style-type: none"> ▪ Energy performance rating (1–100), ▪ Energy reduction percentage (from an average building), ▪ Source and site energy use intensity (kBtu/sf/yr), ▪ Source and site total annual energy use (kBtu), and ▪ Total annual energy cost. Can use to evaluate potential energy savings of new/planned buildings by building type for a clean energy policy (e.g., a building code policy) and apply savings across the population.	http://www.energystar.gov/targetfinder
ENERGY STAR Portfolio Manager	Existing buildings Portfolio of buildings	Online, interactive tool that benchmarks the performance of existing commercial buildings on a scale of 1-100 relative to similar buildings. Tracks energy and water consumption for building or portfolio of buildings and calculates energy consumption and average energy intensity. Can use to evaluate potential energy savings of existing buildings by building type for a clean energy policy (e.g., a building code policy) and apply savings across the population.	https://www.energystar.gov/benchmark
PVWatts™	Grid-connected PV systems	A solar technical analysis model available from NREL that produces an estimate of monthly and annual photovoltaic production (kWh) and cost savings. Users can select geographic location and use either default system parameters or specify parameters for their PV system. Data can be used to accumulate project specific savings toward renewable energy policy goals for solar-related technologies.	http://rredc.nrel.gov/solar/codes_algs/PVWATTS/version1/
<i>Spreadsheet Based Methods</i>			
WindPro	Wind turbines Wind farms	A Windows modular-based software suite for designing and planning single wind turbines and wind farms.	EMD International, WindPro: http://www.emd.dk/WindPRO/Introduction/

TABLE 2.2.6 EXAMPLES OF AVAILABLE TOOLS FOR ESTIMATING DIRECT ENERGY IMPACTS (cont.)

Tool Name	Level of Analysis	Description	Source
RETScreen® Clean Energy Project Analysis Software	Renewable energy and energy efficiency projects	Use to evaluate the energy production and savings, costs, emission reductions, financial viability, and risk for various types of clean energy technologies, including renewable energy, cogeneration, district energy, clean power, heating and cooling technologies, and energy efficiency measures.	http://www.retscreen.net/ang/home.php
DSMore™	DSM programs	Designed to evaluate the costs, benefits, and risks of DSM programs and services. Evaluates thousands of DSM scenarios over a range of weather and market price conditions. While requiring detailed input data, the model uses these data to produce detailed outputs, including energy savings impacts associated with the type of fuel that is being saved (gas or electricity), and provides for expansive scenario analyses.	Integral Analytics: http://www.integralanalytics.com/dsmore.php
Software Methods			
fChart and PV-fChart	Solar PV or solar thermal systems	fChart Software produces both fChart and PV-fChart for the design of solar thermal and photovoltaic systems, respectively. Both programs provide estimates of performance and economic evaluation of a specific design using design methods based on monthly data.	http://www.fchart.com/index.shtml
eQuest®	Buildings	Building simulation model for weather-dependent energy efficiency measures, Energy savings can be applied across the population.	http://www.doe2.com/equest/
ENERGY-10™	Buildings	Small commercial and residential building simulation models. Can conduct a whole-building analysis, evaluating the energy and cost savings that can be achieved by applying energy-efficient strategies such as daylighting, passive solar heating, and high-performance windows and lighting systems.	http://www.nrel.gov/buildings/energy10.html
DOE-2	Buildings	A building energy analysis computer program that predicts the hourly energy use and energy cost of a building given hourly weather information and a description of the building and its HVAC equipment and utility rate structure.	http://www.doe2.com/DOE2/index.html

(http://web.mit.edu/agrea/docs/MIT-LFEE_2004-003a_ES.pdf). Another useful source is the Connecticut Energy Conservation Management Board (<http://www.ctsavesenergy.org/ecmb/index.php>).

- The California Database for Energy Efficient Resources provides estimates of energy and peak demand savings values, measure costs, and effective useful life of efficiency measures (<http://www.energy.ca.gov/deer/>).
- Some states or regions have technology production profiles in their efficiency and renewable energy potential studies (e.g., NYSERDA's report, *Energy Efficiency and Renewable Energy*

Resource Development Potential in New York State, 2003, available at <http://www.nyserda.org/sep/EE&ERpotentialVolume1.pdf>).

- Load Impact Profile Data for energy efficiency measures may be available for purchase from various vendors, but typically is not publicly available in any comprehensive manner.
- Wind profiles can be obtained from a number of sources, including the Department of Energy's NEMS model (<http://www.eia.doe.gov/oiaf/aeo/overview/>), NREL (www.nrel.gov), the American Wind Energy Association (www.awea.org), and several research organizations that have published

information on wind resources in specific locations. All data will likely require some extrapolation or transposition for the intended use.

Considerations

When estimating the potential direct energy impacts, states should consider the cost-effectiveness of the measure or programs in the context of the avoided costs¹² of the utility system or region where they are implemented. To evaluate cost-effectiveness, states can conduct simple economic analyses such as project-level discounted cash flow analysis. Using cash flow analysis, the state develops estimates of the discounted cash flow of alternative options reflecting any incentives available under the program or policy, and simply compares those with avoided costs (obtained from the PUC or other entity, or estimated as discussed in Chapter 3) in the region. For financial incentive-based programs, measures that are less than the avoided cost (considering the incentive) could be expected to enter the mix. For renewable mandates, technologies ranging from least-to-most cost could be considered part of the potential compliance set up to the minimum amount of capacity required by the portfolio standard or goal.

It is important to remember, for this and more sophisticated methods, that there will be some degree of non-compliance for certain mandated programs. For example, building codes do not achieve 100 percent compliance and enforcement is not complete. Calculations should factor non-compliance into the equation.

There are limits to this methodology. For example, the revenue stream received by renewables will depend on when they are operative (especially in competitive markets). This method would miss the true distribution of costs that developers would face, and thus would provide only a rough estimate of the financial performance of these projects. It is important to note that more sophisticated methods require this same data for modeling the performance, economics, and penetration of these technologies.

STEP 3.3: Determine Assumptions and Review Available Data

Determining potential direct energy impacts attributable to clean energy programs and policies requires careful selection of assumptions based on state-specific demographic and climatic conditions. Several

assumptions should be considered when estimating the prospective energy savings of a clean energy initiative. These include:

- *Program period:* What year does the program start? End?
- *Program target:* What sector or consumer type is the focus of the program?
- *Anticipated compliance or penetration rate:* How many utilities will achieve the target or standard called for? How many consumers will invest in new equipment based on the initiative? How will this rate change over the time period?
- *Annual degradation factor:* how quickly will the performance of the measure installed degrade or become less efficient?
- *Transmission and distribution (T&D) loss:* Is there an increase or decrease in T&D losses that would require adjustment of the energy savings estimate?
- *Adjustment factor:* How should the estimate be adjusted to factor in any inaccuracies in the calculation process?
- *Non-program effects:* What portion of the savings is due to factors outside of the initiative?
- *Funding and administration:* What is the budget for the program and how will it be administered? What are the administrative costs? How much will this reduce the amount of money available to directly obtain energy savings?
- *Energy efficiency and renewable energy potential:* How do the savings projected compare to the potential available? Are they realistic and consistent with other relevant studies?

States can look to existing analyses to discover the assumptions others have made while analyzing similar programs. Multiple resources provide historical results and projected EE and RE energy savings, including those listed in Table 2.2.1. Other data sources include the U.S. ENERGY STAR Program,¹³ the various utility online audit services, and manufacturers and national retailers. States can look to other state agencies (e.g., state energy and environmental offices) that may be working on similar studies and have data on clean energy estimates. Step 3.2 *Choose Method to Estimate*

¹² For more information about avoided costs, see Chapter 3, *Assessing the Electric System Benefits of Clean Energy*.

¹³ <http://www.energystar.gov/>

Potential Direct Energy Impacts contains examples of publicly available EE and RE data resources.

Additionally, states can assess available potential studies that support the clean energy policy decision. For example, a potential study conducted for another state may contain valuable information on the energy savings associated with different clean energy programs, and deemed savings databases from other states will include energy savings for specific EE measures.¹⁴ Public service commissions' Web sites usually post utility DSM filings and Integrated Resource Plans, which contain details on EE and RE plans with estimated energy savings.

In using data from other states or regions, it is important to choose states that have similar climate and customer characteristics. Even so, the assumptions about operating characteristics of different clean energy technologies typically need to be adjusted for the specifics of the state that is the focus of the study. For example, for energy efficiency measures, adjustments for differences in weather are typically made, along with adjustments for state-specific population characteristics.

STEP 3.4: Apply Model or Approach

In this step, states use the assumptions they develop and apply the selected model or approach to the clean energy initiative to estimate clean energy savings.

Examples of simple, bottom-up analyses of policy options are presented below for appliance efficiency standards, renewable portfolio standards, and lead by example initiatives.

Air Conditioner Efficiency Standards

A state that is considering a new efficiency standard for air conditioning could estimate energy savings based on a variety of already-available data. The assessment could use measure-specific energy savings from a deemed savings database from another state (e.g., the California Database of Energy Efficiency Resources), and adjust the measure-specific savings to account for the weather zones present in the state, especially for weather-specific measures such as high-SEER air conditioning. These adjustments might require the use of building simulation models (e.g., eQuest; see Table 2.2.6) to get reasonably accurate estimates of energy savings at the site level. These site-level savings would ideally be

generated for each housing type, air conditioning rating level above federal standards, and weather zone. This can create a large matrix of possible combinations.

Determining baseline market penetration of the higher efficiency technology without conducting surveys of HVAC dealers can be accomplished by reviewing studies of market penetration rates from another state (or states). These studies would need to be from states that had not already adopted a higher efficiency technology standard, and the results of the studies would need to be adjusted for demographic differences between the states.

Combined with some thoughtful analysis, these data can help define the potential energy savings for the proposed air conditioning measures without incurring the time and expense of collecting all new data. Making choices about which data to use and how to make adjustments to those data involves inherent trade-offs between the expected accuracy and the level of effort expended. For example, using other states' existing studies and applying basic adjustments to account for different conditions would require less effort than collecting region-specific data and developing savings models for the local environment, but also would be expected to yield a lesser degree of accuracy than would the latter approach. Some analysis of the uncertainty surrounding each key variable is recommended in order to understand the relative accuracy of the estimates obtained through these methods.

Renewable Portfolio Standard

In a similar manner, an estimate of the potential energy savings associated with a renewable portfolio standard (RPS) can use data from surrounding states and/or those that have adopted similar rules regarding the implementation of their RPS. For example, a state might look at adoption rates for roof-mounted solar photovoltaics in other states that have similar net metering rules for solar systems and have established incentives for installation that reward end-users and developers in a similar manner financially.¹⁵

Assumptions regarding the energy production of the system, financial discount rate, and other factors must be reviewed and projected in order to estimate

¹⁴ Deemed savings are validated estimates of energy savings associated with specific energy efficiency measures that may be used in place of project-specific measurement and verification.

¹⁵ If the comparison state's financial incentives took the form of an upfront rebate, and a future revenue stream based on RECs is assumed for the state being analyzed, then a discounted cash flow analysis would be required to analyze the net present value (NPV) of each approach to the project owner and solar developer in order to compare the costs of the two approaches fairly.

attractive rates of return that will stimulate the market at the project level.

To extrapolate the project level analyses to the population, factors including demographic data, the current status of the solar industry in the state, and the current economic climate are required to estimate a range of savings that may be achieved through the policy over a period of several years.

Lead by Example

To determine the energy savings from a *lead by example* policy of reducing energy consumption in all state-owned buildings 20 percent by 2020, a few basic steps are required. The first is to gather the baseline data for state-owned facilities, specifically their energy consumption data for at least the past several years, along with the square footage associated with each facility. These data may take some time and effort to gather, as they do not typically reside in one file or with one person.

Having the baseline data allows for summation of the target kWh and therm reductions across all facilities. If the policy will reduce energy consumption in existing buildings alone, calculating the savings number is as simple as determining whether each facility will achieve 20 percent savings, or the portfolio as a whole will achieve a 20 percent reduction in annual consumption. Either way, it is a straightforward exercise to take 20 percent of the kWh and therms usage summed for the base year. If the policy is to include new construction as well, a determination of what the baseline construction would have been for new state facilities in the absence of the initiative, and an assessment of the energy consumption associated with facilities built to that evolving standard multiplied by the square footage of planned additions, are needed.

To build a true bottom-up analysis of savings, though, it is necessary to find where the 20 percent savings are likely to come from. Individual building audits will provide the best data on where to achieve savings, and can be summed by end-use, facility, and organization up to the state level. But this process is relatively expensive and time consuming, and a first-level screening might involve benchmarking the facilities with national averages and best-practice energy consumption per square foot.¹⁶

¹⁶ When benchmarking facilities in this way, it is important to use benchmarks specific to that building type. For example, a hospital has a very different energy profile than does an office building, so only hospital-specific benchmarks would be useful for benchmarking a hospital. See ENERGY STAR's Portfolio Manager at <http://www.energystar.gov/benchmark>.

After initial screening, walk-through audits can be used to confirm where to target the most cost-effective initial investments. Most cost-effective energy efforts start with lighting retrofits, as they are a proven energy savings that can be easily achieved. Heating, ventilating, and air conditioning improvements or control system upgrades will require a more detailed audit, often take longer to complete, and require less modular investments. Engineering algorithms or simulation models are used to estimate the savings from HVAC and other EE measures, and to estimate interactive effects that may decrease the combined savings of individual measures.

The level of detail desired may depend on the purpose of the estimates. If, for example, agency budgets were dependent upon their energy savings, a more detailed analysis would provide better information about specific technology performance and payback than a screening-type of analysis. Regardless of the level of detail, the state would sum up the measure and building savings estimates across all facilities to assure that the 20 percent by 2020 statewide target can be met within the budgets allocated.¹⁷

STEP 3.5: Evaluate Output

Once potential energy savings or generation impacts are estimated, it is important to evaluate these results to ensure that the numbers are reasonable and meet the state's policy goals. If the state determines that the results are not realistic, it may need to review its assumptions and reapply the approach or model in an iterative fashion to achieve reasonable energy savings estimates. The resulting energy savings estimates can be compared to a potential study, if available, to ensure that the policy analysis does not overestimate the possible savings.

2.2.4 STEP 4.0: CREATE AN ALTERNATIVE POLICY FORECAST

Once the direct energy impacts of clean energy are estimated, an alternative policy forecast must be created that adjusts the BAU energy forecast developed under Step 1 to reflect the clean energy policy or program. In the case of efficiency, the energy savings estimates would be subtracted from the BAU forecast to create a

¹⁷ Of course, other financing mechanisms for energy efficiency are available, including bidding out the services to Energy Service Companies (ESCOs). This chapter does not explore financing mechanisms, but focuses on energy savings calculation methods and mentions the budget implications only as a consideration for policy makers.

new forecast.¹⁸ For clean energy supply alternatives, the policy forecast can be created with the sophisticated supply forecasting models used to develop the original BAU forecast (see Table 2.2.3). The assumptions in the model would need to be adjusted to reflect the change in renewable energy supply expected from the clean energy initiative.

The impact estimates – and many of the same sophisticated demand and supply models – can also be used to assess impacts on the electric power system and project what generation is likely to be displaced that otherwise would have been in operation. This is discussed in more detail in Chapter 3, Assessing the Electric System Benefits of Clean Energy. In addition, the estimates can also be used to determine environmental and economic benefits as described in Chapters 4 and 5 respectively.

ISSUES AND CONSIDERATIONS

- Incentives that are associated with the clean energy policy can alter the energy savings estimates (e.g., a renewable tax credit could increase renewable energy production beyond RPS levels). If historical trends do not reflect these incentives, or non-economic based methods are used, states should attempt to reflect the potential response to these incentives.
- Technologies change over time and can alter energy savings estimates. This can alter the BAU forecast and the potential for energy savings. BAU forecasts and energy savings projections should be reevaluated periodically (every one to two years). This is particularly important under conditions of rapid change.
- Measurement and verification studies, which estimate the actual energy savings of a clean energy measure, can be used retrospectively to ensure that an implemented clean energy program's performance was reliably estimated and is meeting the policy goals set out for the program.
- As with all analyses, transparency increases credibility. Be sure to document all sources and assumptions.

¹⁸ Alternatively, two forecasts may be produced, with and without the clean energy, and the difference would represent clean energy impacts. This methodology would be more likely when using bottom-up economic-engineering approaches.

2.3 CASE STUDIES

2.3.1 TEXAS BUILDING CODE

Impacts Assessed:

- Electricity Savings
- NO_x Reductions

Clean Energy Program Description

The Texas Emissions Reduction Plan (TERP), initiated by the Texas Legislature (Senate Bill 5) in 2001, establishes voluntary financial incentive programs and other assistance programs to improve air quality [i.e., ozone formed from nitrogen oxides (NO_x) and volatile organic compounds (VOCs)] in the state. One component of TERP recognizes the importance of energy efficiency and renewable energy measures in contributing to a comprehensive approach for meeting federal air quality standards. Consequently, the legislation requires the Energy Systems Laboratory (ESL) at the Texas Engineering Experiment Station of the Texas A&M University System to submit an annual report to the Texas Commission on Environmental Quality estimating the historical and potential future energy savings from energy building code adoption and, when applicable, from more stringent local codes or above-code performance ratings. The report also includes estimates of the potential NO_x reductions resulting from these energy savings. ESL has conducted this annual analysis since 2002 and submits it in a report entitled “Energy Efficiency/Renewable Energy Impact in the Texas Emissions Reduction Plan.” ESL also provides assistance to building owners on measurement and verification activities.

Method(s) Used

ESL determines the energy savings and resulting NO_x emissions for new residential single- and multi-family construction and for commercial office buildings in Texas counties that have not attained federal air quality standards. Its analysis is based on the energy efficiency provisions of the IRC for single-family residences and the IECC for all other residential and commercial buildings. A brief summary of the approach for estimating energy savings for both types of buildings is provided below.

Residential Buildings. First, new construction activity by county is determined. Next, annual and peak day energy savings (in kWh) attributable to the building code are modeled using a DOE-2 simulation that ESL

developed for the TERP. These estimates are then applied to National Association of Home Builders survey data to determine the appropriate number of housing types.

Commercial Buildings. The process to estimate energy savings begins with estimating the number of buildings and relative energy savings. The Dodge MarkeTrack database provides construction start data and is used to gather the square footage of new commercial construction in Texas. These data are merged with energy savings calculations published by the Pacific Northwest National Laboratory (PNNL), along with the 1995 and 2003 Commercial Building Energy Consumption database. The PNNL energy savings, which represent buildings built to ASHRAE Standard 90.1-1989 versus Standard 90.1-1999, are applied to the published square feet of new construction.

After residential and commercial building savings are estimated, these savings are projected to 2013 by incorporating a variety of adjustment factors. These factors include:

- *Annual degradation factor:* This factor was used to account for an assumed decrease in the performance of the measures installed as the equipment wears down and degrades. An annual degradation factor of 5 percent was used for all the programs. This value was taken from a study by Kats et al. (1996).
- *T&D loss:* This factor adjusts the reported savings to account for the loss in energy resulting from the transmission and distribution of the power from the electricity producers to the electricity consumers. For this calculation, the energy savings reported at the consumer level were increased by 7 percent to give credit for the actual power produced that is lost in the transmission and distribution system on its way to the customer. In the case of electricity generated by wind, it was assumed there was no net increase or decrease in T&D losses, since wind energy is displacing power produced by conventional power plants.
- *Initial discount factor:* This factor was used to discount the reported savings for any inaccuracies in the assumptions and methods employed in the calculation procedures. For single- and multi-family programs, the discount factor was assumed to be 20 percent.

- *Annual growth factor* for single-family (3.25 percent), multi-family (1.54 percent), and for commercial (3.25 percent) construction, derived from recent U.S. Census data for Texas.

The state assumed that the same amount of electricity savings from the code-compliant construction would be achieved for each year after 2007 through 2013.

Results

- The ESL 2008 annual report on the energy efficiency and renewable energy impacts of the TERP, submitted to the Texas Commission on Environmental Quality in December 2008, describes prospective energy savings resulting from implementing the International Residential Code (IRC) and the International Energy Conservation Code (IECC) in residential and commercial buildings, respectively, through 2020. According to the report, the cumulative annual energy savings from code-compliant residential and commercial construction were estimated to be:
 - 1,440,885 megawatt hours (MWh) of electricity each year from 2001 through 2007, and
 - approximately 2.9 million MWh by 2013, accounting for 10 percent of the cumulative total electricity savings under all energy efficiency and renewable energy programs implemented under the TERP between 2008 and 2013 (Texas A&M Energy Systems Laboratory, 2007).

ESL divided the actual and projected energy savings into the different Power Control Authorities and, using US EPA's eGRID emission factors, calculated the cumulative annual NO_x emission reduction values as follows:

- 1,014 tons-NO_x/year in 2007, and
- 2,047 tons/year by 2013.

For More Information

- *Energy Efficiency/Renewable Energy Impact in The Texas Emissions Reduction Plan (TERP).* Volume I—Summary Report: Annual Report to the Texas Commission on Environmental Quality. January 2007–December 2007. August 2008, Revised December 2008. Energy Systems Laboratory, Texas Engineering Experiment Station, Texas A&M University System. <http://esl.eslwin.tamu.edu/docs/documents/tceq/ESL-TR-08-12-01%20tceq-report-2007-Vol-I-FINAL.pdf>

- *Energy Efficiency/Renewable Energy Impact In The Texas Emissions Reduction Plan (TERP)*. Preliminary Report: Integrated NO_x Emissions Savings From EE/RE Programs Statewide: Annual Report to the Texas Commission on Environmental Quality January 2007–December 2007. August 2008. <http://esl.eslwin.tamu.edu/docs/documents/ESL-TR-08-08-01.pdf>
- *Development of a Web-based Emissions Reduction Calculator for Code-Compliant Commercial Construction*. Texas A&M Energy Systems Laboratory. 2005. <http://txspace.tamu.edu/bitstream/handle/1969.1/5128/ESL-IC-05-10-34.pdf?sequence=1>.
- *Development of a Web-based Emissions Reduction Calculator for Code-Compliant Single-Family and Multi-Family Construction*. Texas A&M Energy Systems Laboratory. 2005. <http://txspace.tamu.edu/bitstream/handle/1969.1/5127/ESL-IC-05-10-33.pdf?sequence=1>.

2.3.2 VERMONT - ENERGY AND ENERGY SAVINGS FORECASTING

Activities:

- Energy forecasting
- Energy savings forecasting

Background

The Vermont Department of Public Service (DPS) conducts energy demand and energy efficiency program savings forecasting as part of its long-term state energy policy and planning process. This process includes:

- The Comprehensive Energy Plan (CEP, required under statute to be conducted every five years),
- The 20-Year Electric Plan (also required every five years), and
- A variety of other state planning initiatives (Vermont DPS, 2008).

The state uses the CEP as a tool to help manage the transition from traditional energy fossil fuel to cleaner energy supplies in order to benefit Vermont’s economic and environmental future. It provides a means for them to show how energy demand and energy efficiency program forecasts fit into the bigger planning picture.

TABLE 2.3.1 VERMONT PROJECTED ENERGY DEMAND 2008-2010: WITH AND WITHOUT NEW DSM

Year	Without New DSM (GWh)	With New DSM (GWh)	Energy Savings (GWh)
2008	6,356	6,356	0
2009	6,324	6,256	68
2010	6,436	6,243	193
2011	6,552	6,235	317
2012	6,685	6,242	443
2013	6,821	6,254	567
2014	6,925	6,253	672
2015	6,941	6,181	760
2016	6,977	6,131	846
2017	7,042	6,110	932
2018	7,123	6,107	1,016
2019	7,205	6,105	1,100
2020	7,293	6,113	1,180
2021	7,381	6,125	1,256
2022	7,370	6,046	1,324
2023	7,440	6,059	1,381
2024	7,516	6,089	1,427
2025	7,583	6,121	1,462
2026	7,634	6,146	1,488
2027	7,681	6,171	1,510
2028	7,648	6,120	1,528
Total	148,933	129,463	19,470
AAGR	0.93%	- 0.19%	

AAGR=Average Annual Rate of Growth

Method(s) Used

For the 2008 study, the Vermont DPS began its analysis by examining historical energy consumption in Vermont across all sectors by selected fuel categories between 1960 and 2005. It also uses the historical data to compare energy demand in Vermont with demand in New England and the United States from 1990 through 2004.

The process to forecast electricity and peak demand in the state required several steps:

1. *Determine fuel price projections and avoided costs* (i.e., the marginal energy supply costs that will be avoided through savings in electricity, natural gas,

and other fuels from a range of DSM programs.) Consultants used DOE fuel price projections, customized them to Vermont conditions, and determined avoided costs using a screening tool that contains load shapes for each measure and type of program.¹⁹

2. *Estimate the achievable, cost-effective potential for electric energy and peak demand savings.* The level of efficiency potential in Vermont by DSM programs was determined using the avoided cost estimates from the first step along with various cost-effectiveness tests (GDS, 2006).
3. *Develop a 20-year forecast of electric energy use.* DPS hired consultants to develop a baseline projection of energy demand given current trends and use patterns and a forecast of expected demand, assuming implementation of the new DSM measures, built up from estimates of energy use by appliance type and end-use category by sector (e.g., the number of refrigerators in the residential sector) and the savings potential for each. Using regression and trend analysis, Vermont ran one 20-year baseline forecast without new (projected) DSM programs, and one case with assumed levels of new DSM program activity.²⁰
4. *Develop a peak demand forecast.* DPS also looked at DSM savings using an econometric model base that included historical DSM investments as an independent variable. This method took a more conservative approach than the regression analysis used to project electric energy demand, in that it gives equal weight to the past 20 years of DSM program impacts and so may understate the credit deserved by energy efficiency measures going forward.

Results

These historical data and the analysis show demand for energy growing, driven by population growth, economic development, larger homes, and increases in vehicular travel. While overall energy demand appeared to show more rapid growth in Vermont than for the United States and New England, the reverse is true

¹⁹ The fuel cost and avoided cost assumptions were extensively reviewed by the Avoided Energy Supply Component Study Group, composed of New England utilities and PUCs.

²⁰ The regression equation includes variables for personal income, price, and trends to predict energy sales. The “with DSM” forecast was developed by subtracting the DSM savings projections from the base case “without DSM” forecast.

within the electricity sector, which has been the object of intensive, formal energy efficiency program investments through Vermont’s Energy Efficiency Utility. In addition, Vermont faces a large supply gap if major power contracts are not replaced, and the state projects higher costs for new resources to replace them. In light of this, Vermont committed itself to pursuing very aggressive energy efficiency measures.

Based on the energy efficiency potential results determined above, the DPS recommended DSM policies and a budget for programs. The Vermont Public Service Board approved the budgets and the Efficiency Utility established the specific programs (subject to Public Service Board review).

The electricity forecasts projected that without new DSM measures, electricity demand would grow an average of 0.93 percent on an average annual basis between 2008 and 2028. When new DSM measures are implemented, the DPS anticipates that energy demand will remain fairly flat, with a decline of 0.19 percent on an average annual basis.

The Vermont DPS is currently developing a comprehensive modeling approach using system dynamics (possibly relying on its older Energy 2020 model) to forecast energy savings from its DSM programs that would, ideally, better integrate the steps of its existing approach.

For More Information

- *Vermont Electric Energy Efficiency Potential Study, Final Report.* GDS Associates, Inc. May 10, 2006. Prepared for the Vermont Department of Public Service. <http://www.state.vt.us/psb/document/ElectricInitiatives/FinalReport-05-10-2006.doc>.
- *Vermont Comprehensive Energy Plan 2009 and Update to the 2005 Twenty-Year Electric Plan, Public Review Draft.* Vermont Department of Public Service. May 2008. <http://publicservice.vermont.gov/planning/CEP%20%20WEB%20DRAFT%20FINAL%206-4-08.pdf>.
- *Vermont’s Energy Forecasting Efforts.* Vermont Department of Public Service. June 19, 2008. http://www.epa.gov/statelocalclimate/documents/pdf/presentations_vt.pdf.

Information Resources	URL Address
California Energy Commission (CEC). 2005. Energy Demand Forecast Methods Report. Companion Report to the California Energy Demand 2006–2016 Staff Energy Demand Forecast Report.	http://www.energy.ca.gov/2005publications/CEC-400-2005-036/CEC-400-2005-036.PDF
CEC. 2007. California Energy Demand 2008-2018, Staff Revised Forecast	http://www.energy.ca.gov/2007publications/CEC-200-2007-015/CEC-200-2007-015-SF2.PDF
Energy Information Administration (EIA). Commercial Buildings Energy Consumption Survey.	http://www.eia.doe.gov/emeu/cbecs/
EIA. Manufacturing Energy Consumption Survey.	http://www.eia.doe.gov/emeu/mecs/
EIA. Residential Energy Consumption Survey.	http://www.eia.doe.gov/emeu/recs/
Elliott, R. Neal and Anna Monis Shipley. 2005. Impacts of Energy Efficiency and Renewable Energy on Natural Gas Markets: Updated and Expanded Analysis. American Council for an Energy-Efficient Economy. April.	http://www.aceee.org/pubs/e052full.pdf
Elliot, R. Neal and Maggie Eldridge. 2007. Role of Energy Efficiency and Onsite Renewables in Meeting Energy and Environmental Needs in the Dallas/Fort Worth and Houston/Galveston Metro Areas. American Council for an Energy-Efficient Economy. September.	http://aceee.org/pubs/e078.pdf
Massachusetts. 2001. Energy Efficiency Activities 1999, A Report by the Division of Energy Resources.	http://www.mass.gov/Eoca/docs/doer/pub_info/ee99-long.pdf
Myers, Stephen, James McMahon, and Michael McNeil. 2005. Realized and Prospective Impacts of U.S. Energy Efficiency Standards for Residential Appliances: 2004 Update. Lawrence Berkeley National Laboratory, LBNL-56417. May.	http://repositories.cdlib.org/lbnl/LBNL-56417/
New Jersey. Market Analysis and Baseline Studies.	http://www.njcleanenergy.com/main/public-reports-and-library/market-analysis-protocols/market-analysis-baseline-studies/renewable
Navigant Consulting Inc., Sustainable Energy Advantage LLC, and Boreal Renewable Energy Development. 2004. New Jersey Renewable Energy Market Assessment Final Report, August 2004, to Rutgers University Center for Energy, Economic and Environmental Policy.	http://policy.rutgers.edu/ceeep/publications/2004/remareport.pdf
National Renewable Energy Laboratory (NREL). Energy Analysis – Slide Library.	http://www.nrel.gov/analysis/slide_library.html
NREL. Wind Research – Baseline Cost of Energy.	http://www.nrel.gov/wind/coe.html
New York State Energy Research and Development Authority (NYSERDA). 2005. Executive Order No. 111 “Green and Clean” State Buildings and Vehicles. New York State Energy Research and Development Authority.	http://www.nyserda.org/programs/pdfs/execorder111finalreport11-05.pdf
Summit Blue Consulting. 2008. Assessment of the New Jersey Renewable Energy Market, Volume I and II. Prepared for the New Jersey Board of Public Utilities. March.	http://www.njcleanenergy.com/main/public-reports-and-library/market-analysis-protocols/market-analysis-baseline-studies/renewable
Texas A&M Energy Systems Laboratory (ESL). 2005. Development of a Web-based Emissions Reduction Calculator for Code-Compliant Commercial Construction.	http://txspace.tamu.edu/bitstream/handle/1969.1/5128/ESL-IC-05-10-34.pdf?sequence=1
Texas A&M ESL. 2005. Development of a Web-based Emissions Reduction Calculator for Code-Compliant Single-Family and Multi-Family Construction.	http://txspace.tamu.edu/bitstream/handle/1969.1/5127/ESL-IC-05-10-33.pdf?sequence=1
U.S. Environmental Protection Agency (EPA). ENERGY STAR.	http://www.energystar.gov/

Information Resources	URL Address
U.S. EPA. 2006. Clean Energy-Environment Guide to Action: Policies, Best Practices, and Action Steps for States. April.	http://www.epa.gov/statelocalclimate/resources/action-guide.html
Vermont Department of Public Service. 2008a. Vermont's Energy Forecasting Efforts. June 19.	http://www.epa.gov/statelocalclimate/documents/pdf/presentations_vt.pdf
Vermont Department of Public Service. 2008b. Personal communications with Riley Allen, Director of Planning, and Dave Lamont, Planning Engineer. 7/25/2008.	N/A

References	URL Address
GDS Associates, Inc. 2006. Vermont Electric Energy Efficiency Potential Study, Final Report. Prepared for the Vermont Department of Public Service. May 10.	http://www.state.vt.us/psb/document/ElectricInitiatives/FinalReport-05-10-2006.doc
Kats, G.H., Arthur H. Rosenfeld, and Scott A. McGaraghan. 1996. Energy Efficiency as a Commodity: The Emergence of a Secondary Market for Efficiency Savings in Commercial Buildings. European Council for an Energy Efficient Economy.	http://www.eceee.org/conference_proceedings/eceee/1997/Panel_2/p2_26/Paper/
New Jersey. 2008. New Jersey Draft Energy Master Plan. April.	http://www.state.nj.us/emp/home/docs/pdf/draftemp.pdf (draft plan) http://www.state.nj.us/emp/ (all related reports)
NYSERDA. 2005. New York Energy \$SMART SM Program, Evaluation and Status Report for the Year Ending December 2004. New York Public Service Commission and New York State Energy Research and Development Authority. May.	http://www.nyserda.org/Energy_Information/SBC/sbcmay05summary.pdf
NYSERDA. 2008. New York Energy \$SMART SM Program, Evaluation and Status Report for the Year Ending December 2007. New York Public Service Commission and New York State Energy Research and Development Authority. March.	http://www.nyserda.org/pdfs/Combined%20Report.pdf
Texas A&M Energy Systems Laboratory (ESL). 2007. Energy Efficiency/Renewable Energy Impact in the Texas Emissions Reduction Plan (TERP). Volume II- Technical Report.	http://txspace.tamu.edu/bitstream/handle/1969.1/2077/ESL-TR-04-12-04.pdf?sequence=1
Vermont Department of Public Service. 2008. Vermont Comprehensive Energy Plan 2009 and Update to the 2005 Twenty-Year Electric Plan, Public Review Draft. May.	http://www.publicservice.vt.gov/planning/CEP%20%20WEB%20DRAFT%20FINAL%206-4-08.pdf
Wisconsin Office of Energy Independence. 2007. Wisconsin Energy Statistics.	http://energyindependence.wi.gov/docview.asp?docid=11632&locid=160

CHAPTER THREE

Assessing the Electric System Benefits of Clean Energy

Clean energy programs and policies can help states achieve their goal of providing a less polluting, more reliable and affordable electric system that addresses multiple challenges, including:

- Lowering energy costs for customers and utilities alike, particularly during periods of peak electricity demand;¹
- Improving the reliability of the electricity system and averting blackouts at a lower cost;
- Reducing the need for new construction of generating, transmission, and distribution capacity; and
- Providing targeted reductions in load (i.e., the amount of electric power or the amount of power demanded by consumers at a given time) in grid-congested areas, such as southwestern Connecticut and San Francisco, California.

Many states are evaluating the electric system benefits of clean energy. These benefits, as described above, go beyond the direct energy savings and renewable energy generation impacts discussed in Chapter 2, *Assessing the Potential Energy Impacts of Clean Energy Initiatives*. This chapter provides an overview of methods that can be used to undertake broad assessments of the impacts

¹ Just as energy efficiency program economics can be evaluated from a variety of perspectives (total resource costs, program administration costs, ratepayer, participant, and society) so can the benefits of clean energy programs. For each perspective, the benefits of clean energy are defined differently. In this guide, we are examining the equivalent of the total resource cost perspective, considering benefits (and costs) to the participants and the utility. While other perspectives including the utility costs are important, we focus on those perspectives most important to policymakers and clean energy program administrators. For more information about the different perspectives used to evaluate the economics of programs, see *Understanding Cost-Effectiveness of Energy Efficiency Programs: Best Practices, Technical Methods, and Emerging Issues for Policy-Makers: A Resource of the National Action Plan for Energy Efficiency*, November 2008. www.epa.gov/cleanenergy/documents/cost-effectiveness.pdf.

DOCUMENT MAP

- CHAPTER ONE
Introduction
- CHAPTER TWO
Potential Energy Impacts of Clean Energy
- CHAPTER THREE
Electric System Benefits of Clean Energy
- CHAPTER FOUR
Air Quality Benefits of Clean Energy
- CHAPTER FIVE
Economic Benefits of Clean Energy
- APPENDIX A
Catalogue of Clean Energy Case Studies
- APPENDIX B
Tools and Models Referenced in Each Chapter

CHAPTER THREE CONTENTS

3.1	How Clean Energy Can Achieve Electric System Benefits	53
3.1.1	The Structure of the U.S. Energy System	53
3.1.2	Primary and Secondary Benefits of Clean Energy	54
3.2	How States Can Estimate the Electric System Benefits of Clean Energy	56
3.2.1	How to Estimate the Primary Electric System Benefits of Clean Energy Resources	61
3.2.2	How to Estimate the Secondary Electric System Benefits of Clean Energy Resources	77
3.3	Case Studies	83
3.3.1	California Utilities' Energy Efficiency Programs	83
3.3.2	Energy Efficiency and Distributed Generation in Massachusetts	85
	Information Resources	86
	References	89

STATES ARE QUANTIFYING THE ENERGY SYSTEM BENEFITS OF CLEAN ENERGY POLICIES

Several states have quantified the energy system benefits from their clean energy measures and determined that the measures are providing multiple benefits, including avoiding the costs of electricity generation, reducing peak demand, and improving energy system reliability.

Georgia conducted an assessment of the benefits of achieving energy efficiency improvements in the state and found it could reduce demand for electricity by 3,339 GWh–12,547 GWh in 2010.

In addition to these energy savings, the analysis showed that the improvements could benefit the overall electricity system and:

- Avoid generation in Georgia of 1,207 GWh–4,749 GWh in 2010,
- Reduce regional wholesale electricity cost by 0.5–3.9 percent by 2015, and
- Lower peak demand by 1.7–6.1 percent by 2015 and achieve a number of environmental and economic benefits.

(Jensen and Lounsbury, 2005).

of clean energy on the overall electric system, including effects on electricity generation, capacity, transmission, distribution, power costs, and peak demand.

State legislatures, energy and environmental agencies, regulators, utilities, and other stakeholders (e.g., rate-payer advocates, environmental groups) can quantify and compare the electric system benefits of clean energy resources [e.g., energy efficiency, including some demand response programs such as load control programs, renewable energy, combined heat and power (CHP), and clean distributed generation (DG)] to traditional grid electricity. This information can then be used in many planning and decision-making contexts, including:

- Developing state energy plans and establishing clean energy goals;
- Conducting resource planning (by PUCs or utilities);
- Developing demand-side management (DSM) programs;
- Conducting electric system planning, including new resource additions (e.g., power plants), transmission and distribution capacity, and interconnection policies;

- Planning and regulating air quality, water quality, and land use;
- Obtaining support for specific initiatives; and
- Policy and program design.

Although quantifying electric system benefits can be challenging—particularly when analyzing long-term effects in a complex, interconnected electricity grid—it is important to consider these benefits when evaluating clean energy resources. This chapter presents detailed information about the energy system, specifically electricity benefits of clean energy, to help policy makers understand how to identify and assess these benefits based upon their needs and resources.

- Section 3.1, *How Clean Energy Can Achieve Electric System Benefits*, describes the energy system in the United States and explains the multiple ways that clean energy policies and programs can positively affect the electric system and electricity markets, thereby benefiting consumers, utilities, and society.
- Section 3.2, *How States Can Estimate the Electric System Benefits of Clean Energy*, presents an overview of the methods for estimating the primary and secondary electric system benefits of different types of clean energy resources.
 - Section 3.2.1, *How to Estimate the Primary Electric System Benefits of Clean Energy Resources*, describes the specific basic and sophisticated modeling approaches and associated tools that can be used to quantify a set of typically recognized (i.e., “primary”) benefits.
 - Section 3.2.2, *How to Estimate the Secondary Electric System Benefits of Clean Energy Resources*, describes approaches and tools for estimating other electric system benefits (i.e., “secondary” benefits) that are less frequently assessed and often more difficult to quantify.
- Section 3.3, *Case Studies*, presents examples of how two states, California and Massachusetts, are estimating the electric system benefits of their clean energy programs.

3.1 HOW CLEAN ENERGY CAN ACHIEVE ELECTRIC SYSTEM BENEFITS

Energy is crucial to all aspects of the U.S. economy. This section presents background information on how the U.S. energy system is structured (see Section 3.1.1), and describes the wide range of benefits that clean energy can bring to the electricity component of this system (see Section 3.1.2).

3.1.1 THE STRUCTURE OF THE U.S. ENERGY SYSTEM

The energy system in the United States includes all the steps, fuels, and technologies from the import or extraction of energy resources, to their conversion to useful forms, to their use in meeting end-use energy demands (e.g., by the transportation, industrial, residential, and commercial sectors). Components of the energy supply system include transportation fuels, electricity, and other forms of energy for use in homes, manufacturing, and business. This chapter focuses on several components of the larger electric system: electricity production, transmission, distribution, and the markets by which electricity is bought and sold. These components are hereinafter referred to together as the *electric system*.

The North American electric system acts essentially like four separate systems of supply and demand because it is divided into four interconnected grids in the continental United States and Canada: the Eastern, Western, Quebec, and Electric Reliability Council of Texas (ERCOT) Interconnections. These alternating current (AC) power grids are depicted in Figure 3.1.1, *NERC Interconnections*. Electricity can be imported or exported relatively easily among the numerous power control areas within each interconnection system. However, for reliability purposes, the interconnections have limited connections between them and are connected by direct current (DC) lines.

Balancing the supply of and demand for electricity in an economically efficient manner is complicated by a number of factors. For example, the demand for electricity varies significantly hour by hour, and cyclically by time of day and season. Residential electricity demand peaks in the morning and at night, when more residents are at home and operating heating and air conditioning units, washers, dryers, and other products that use electricity. Commercial and industrial electricity demand varies by type of company or industry, and

FIGURE 3.1.1 NERC INTERCONNECTIONS

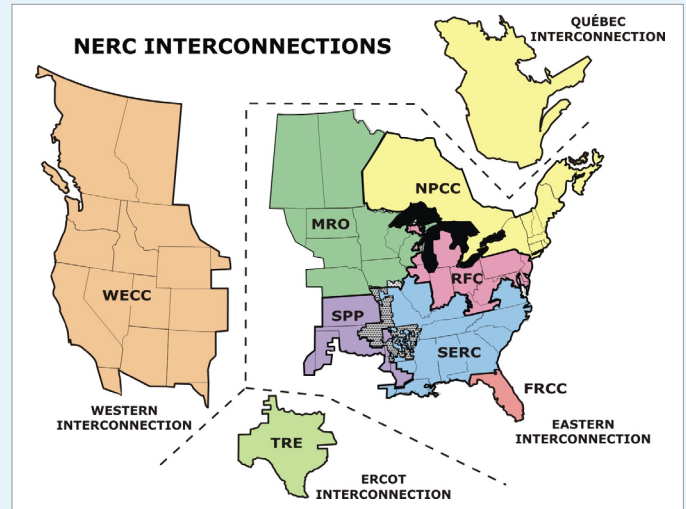

Source: NERC, 2008.

thus may be considerably different from one location to another.

Electricity supply is matched to demand using a portfolio of production technologies. To meet the demand, some power plants operate almost continuously, serving as baseload units (e.g., coal and nuclear plants are examples of baseload units). Each baseload unit has relatively high capital costs, but operational costs are low. Also, startup and shutdown at these plants takes time, is expensive, and causes additional wear on generating units. Other generation sources are operated only during the times of highest demand, serving as “peaking” units. The output of these generators rises and falls throughout the day, responding to changing electricity demand. Natural gas turbines are often used for this purpose. These technologies are expensive to run for long periods but can be started up and shut down quickly. Because electricity must be generated at the same time it is used, meeting peak demand and the related price volatility are key issues.

The source of the electricity supply can also vary. A group of system operators across the region decides when, how, and in what order to dispatch electricity from each power plant in response to the demand at that moment and based on the cost or bid price. In regulated electricity markets, dispatch is based on “merit order” or the variable costs of running the plants. In restructured markets or wholesale capacity markets,

dispatch is based on the generator's bid price into the market. Electricity from the power plants that are least expensive to operate (i.e., the baseload plants) is dispatched first. The power plants that are most expensive to operate (i.e., the peaking units) are dispatched last. The merit order or bid stack is based on fuel costs and plant efficiency, as well as other factors such as emissions allowance prices.

Other conditions also affect electricity supply. Transmission constraints (i.e., when transmission lines become congested) can make it difficult to dispatch electric generators located away from load centers and move their power into areas of high demand, or may require certain units to operate to improve system reliability. Extreme weather events can decrease the ability to import or export power from neighboring areas. "Forced outages," when certain generators or transmission lines are temporarily unavailable, can also shift dispatch to other generators. System operators must keep all these issues in mind when dispatching power plants. States can also take these issues into consideration by using dispatch models or other approaches to estimate which generators would likely reduce their output and their emissions in response to the introduction of clean energy resources.

The electric power transmission system connects power plants to consumers. Figure 3.1.2 depicts the flow of power from the generating station, or power plant, to the transformer and the transmission lines, through the substation transformer (which reduces the voltage) to the distribution lines, and finally, through the pole transformer to the consumer's service box. Electricity *transmission* is typically between the power plant and a substation, and electricity *distribution* is the delivery from the substation to consumers. Electricity is usually transmitted through overhead transmission and distribution lines, although sometimes underground distribution lines are used in densely populated areas. Overlapping lines are provided in the grid so that power can be routed from any power plant to any load center (e.g., populated areas), through a variety of routes. Transmission companies conduct detailed analyses to determine the maximum reliable capacity of each line.

The process of generating, transmitting, and distributing electricity is quite complex and involves many costs. Clean energy provides opportunities for states to reduce many of those costs.

HOW ELECTRIC GENERATORS ARE DISPATCHED

The operation of electric systems is determined by a set of physical constraints and economic objectives, through a process referred to as "economic dispatch." The electric system operator dispatches generating units (i.e., signals generators to start or increase production) in economic merit order—that is, in order of increasing operating costs (starting with the lowest costs adjusted for transmission losses), subject to reliability considerations including transmission constraints. The highest-cost unit dispatched at any point in time is said to be "on the margin" and is known as the "marginal unit." For example, high-cost combustion turbines and gas/oil peaking units are on the margin for many hours of the week. During off-peak times, plants with lower operating costs (e.g., combined cycle gas turbines and coal-fired steam units) can be on the margin. In some regions the cost used for dispatch is the variable cost of running each plant (mainly fuel cost), but in others the criterion for dispatch is a bid price submitted by the owners of the generators.

3.1.2 PRIMARY AND SECONDARY BENEFITS OF CLEAN ENERGY

Clean energy initiatives can result in numerous benefits to the electric system, predominantly through the avoidance of costs associated with generating, transmitting, and distributing electricity. Clean energy is often cheaper than or just as cost-effective as other energy options, while delivering important electric system, environmental, and/or economic benefits to the state. For example, in California, energy efficiency programs have cost the state 2¢–3¢ per kWh on average—much less than the cost of new generation, which can be more than 6¢ per kWh for new natural gas combined cycle plants—while reducing the need for new power plants and increasing reliability (NRDC, 2006). Consequently, quantifying the electric system benefits of clean energy options is central to sound policy planning, contributes to public confidence in clean energy policies, and helps policy makers choose among different approaches to delivering clean energy.

The benefits of clean energy initiatives are categorized in this document as primary and secondary benefits. *Primary benefits* are those electric system benefits that are conventionally recognized for their ability to reduce the overall cost of electric service over time. These benefits can occur over the long run, the short run, or both. Some of these benefits are significant and most can be quantified using well-tested methods. *Secondary benefits* of clean energy are less frequently recognized than primary benefits, and tend to be smaller and/or harder to quantify. Nevertheless, it is useful to identify

FIGURE 3.1.2 FLOW OF ELECTRICITY FROM POWER PLANTS TO CONSUMERS

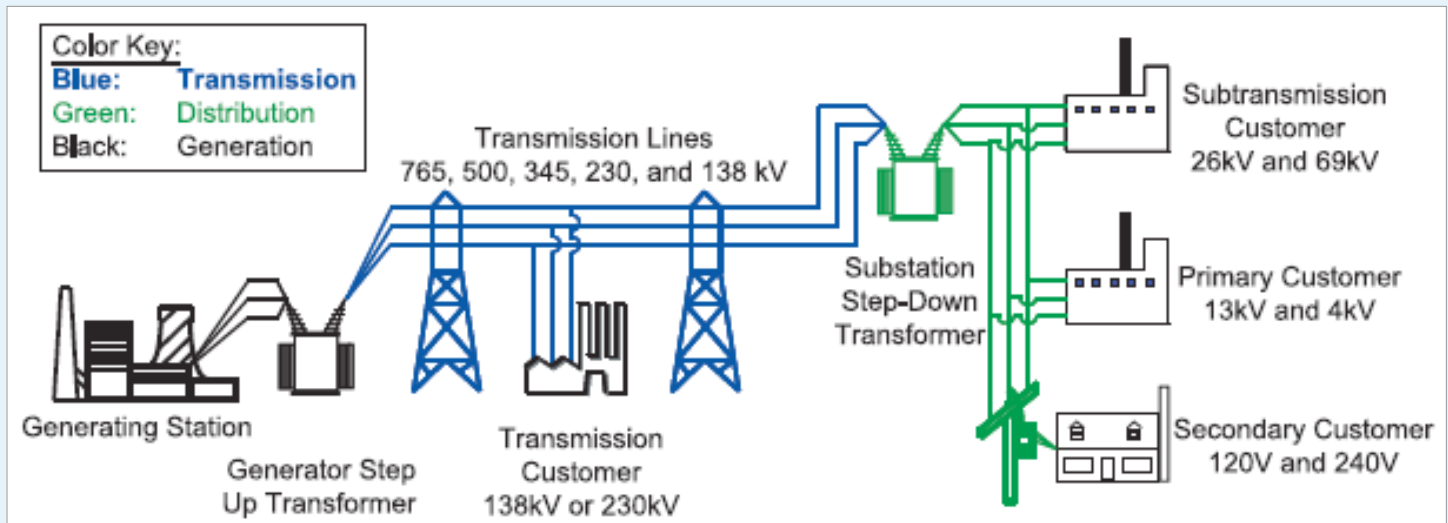

Source: US-Canada Power System Outage Task Force, 2004 <https://reports.energy.gov/BlackoutFinal-Web.pdf>.

these benefits and quantify them, when possible, in order to most accurately reflect both the costs and benefits of clean energy.

The *primary electricity system benefits* of clean energy include:

- *Avoided costs of electricity generation or wholesale electricity purchases.* Clean energy policies and programs can displace electricity generated from fossil fuels (e.g., natural gas, oil, and coal-fired power plants). Savings typically appear as avoided fuel costs and reduced cost for purchased power or transmission service.
- *Deferred or avoided costs of power plant capacity.* Clean energy policies and programs can delay or avoid the need to build or upgrade power plants or reduce the size of needed additions. Typical components are the capital investments and annual fixed costs (e.g., labor, maintenance, taxes, and insurance) not incurred as a result of clean energy initiatives.
- *Avoided electric loss in transmission and distribution (T&D).* The delivery of electricity results in some losses due to the resistance of wires, transformers, and other equipment. For every unit of energy consumption that a clean energy resource avoids at the end-use site, it also avoids the associated ener-

gy loss during delivery of electricity to consumers through the T&D system.²

- *Deferred or avoided costs of T&D capacity.* Clean energy resources that are located close to where energy is consumed can delay or avoid the need to build or upgrade T&D systems or reduce the size of needed additions. These savings can occur over the long run, the short run, or both. Typical components are similar to those for avoided power plant capacity.

Examples of *secondary benefits* include:

- *Avoided ancillary service costs.* Clean energy resources that reduce load, that are located close to where energy is consumed, or that can support smooth operation of the power grid can reduce some ancillary services requirements. Ancillary services are those electric generator functions needed to ensure reliability, as opposed to providing power. Examples include operating reserves (e.g., generators that are up and running to take over if a load-serving generator fails or load spikes) and voltage support (e.g., generators that are running and can tune their output to keep voltage stable). Clean energy resources that reduce the need for ancillary services save fuel and reduce

² It is important to note that clean central-station generation incurs the same T&D losses as fossil-fueled sources.

emissions by allowing some units to shut down and may delay or avoid the need for investment in new generation to provide ancillary services. These include stationary energy storage resources such as batteries and pumped hydro storage. Other clean energy resources, especially demand response resources—such as controls on air conditioning or water heater load control programs—can free up reserves that are needed to respond in the event of a system outage. In some regions, clean energy resources that operate during peak times reduce the required level of operating resources.

- *Reduced wholesale market clearing prices.* Clean energy policies and programs can lower the demand for electricity or increase the supply of electricity, causing wholesale markets to clear at lower prices. This benefit can be dramatic during peak hours.
- *Increased reliability and power quality.* An electric grid is more reliable if the loads are lower, especially during peak hours and in areas where transmission is constrained. Integration of clean energy resources can increase the reliability of the electricity system since power outages are less likely to occur when the system is smaller and not strained; more dispersed resources make the system less vulnerable to outages. In addition, power quality—which is important for the operation of some electrical equipment—can be enhanced by some forms of clean energy resources (e.g., fuel cells).
- *Avoided risks associated with long lead-time investments.* While clean energy resources certainly have some risk (e.g., of underperformance of energy efficiency or renewable energy measures), these resources offer greater flexibility due to their modular, segmented nature, and relatively quick installation and disconnection time compared with traditional resources. As a result, clean energy options increase flexibility to deal with uncertainty (relative to large, traditional fossil fuel resources) by reducing dependence on conventional fuels and allowing planners to be more responsive to deviations from load forecasts. The size of the potential for some clean energy options, such as energy efficiency, is correlated with load, making it especially responsive to changes in the planning environment. In addition, reducing or delaying the need for large utility investments for transmission or generation reduces both the need for large amounts of financing and the chance of failed or unnecessary investments.

- *Reduced risk from deferring investment in traditional, centralized resources until environmental and climate change policies take shape.* Clean energy policies and programs may reduce the cost of future compliance with air pollution control requirements. In addition, clean energy policies and programs may limit exposure to costs from any future carbon regulations.
- *Improved fuel diversity and energy security.* Portfolios that rely heavily on a few energy resources are highly affected by the unique risks associated with any single fuel source (e.g., coal, oil, gas). In contrast, the costs of some clean energy resources are relatively unaffected by fossil fuel prices and thus provide a hedge against fossil-fuel price spikes. Other clean energy resources can be affected by fossil fuel prices. For example, biomass renewables may require fertilizer and/or processing via technologies that use petroleum, natural gas, and/or coal, and because wind provides intermittent power that may not be available at peak demand times, it can require backup peaking units (e.g., natural gas turbines). Overall, however, the greater the diversity in technology the less likelihood of supply interruptions and reliability problems. In addition, using diverse domestic clean energy resources provides energy security by reducing the vulnerability of the electric system to attack and reducing dependence on foreign fuel sources, such as imported petroleum, which may yield political and economic benefits by protecting consumers from supply shortages and price shocks

Table 3.1.1 summarizes the traditional costs of generating, transmitting, and distributing electricity, and describes the primary and secondary clean energy benefits associated with each type of cost.

3.2 HOW STATES CAN ESTIMATE THE ELECTRIC SYSTEM BENEFITS OF CLEAN ENERGY

The rigor with which states can or may want to analyze the electric system benefits of clean energy depends on the type of benefit being analyzed, the clean energy proposal's status in the development and design process, the level of investment under consideration, regulatory and system operator requirements, resources (e.g., computers, staff) available for the analysis and, for some benefits, the utility or region.

TABLE 3.1.1 ELECTRIC SYSTEM COSTS AND THE PRIMARY AND SECONDARY BENEFITS OF CLEAN ENERGY

Traditional Costs	Primary Benefits of Clean Energy	Secondary Benefits of Clean Energy	Description of Benefit	Section
Generation				
<ul style="list-style-type: none"> ▪ Fuel ▪ Variable operation and maintenance ▪ Emissions Allowances 	<ul style="list-style-type: none"> ▪ Avoided costs of electricity generation or wholesale electricity purchases. 	<ul style="list-style-type: none"> ▪ Reduced risk from investment in traditional, centralized resources before environmental and climate change policies take shape. ▪ Improved fuel and energy security. 	<ul style="list-style-type: none"> ▪ Clean energy policies and programs can displace traditional electric energy generation. 	3.2.1a
		<ul style="list-style-type: none"> ▪ Avoided ancillary services. ▪ Reductions in wholesale market clearing prices. ▪ Increased reliability and power quality. ▪ Avoided risks associated with long lead-time investments (e.g., risk of overbuilding the electric system). 	<ul style="list-style-type: none"> ▪ Clean energy policies and programs can lower the demand for electricity or increase the supply of electricity, causing wholesale markets to clear at lower prices. 	
<ul style="list-style-type: none"> ▪ Capital and operating costs of upgrades ▪ Fixed operation and maintenance ▪ New construction to increase capacity 	<ul style="list-style-type: none"> ▪ Avoided costs of power plant capacity. 		<ul style="list-style-type: none"> ▪ Clean energy policies and programs can delay or avoid the need to build or upgrade power plants. 	3.2.1b
Transmission & Distribution				
<ul style="list-style-type: none"> ▪ Capital and operating costs of maintenance ▪ Upgrades ▪ New construction 	<ul style="list-style-type: none"> ▪ Deferred or avoided costs of transmission & distribution (T&D) capacity. 	<ul style="list-style-type: none"> ▪ Increased reliability and power quality. 	<ul style="list-style-type: none"> ▪ Clean energy policies and programs that are located close to where energy is consumed can delay or avoid the need to build or upgrade T&D systems. 	3.2.1c
<ul style="list-style-type: none"> ▪ Energy losses 	<ul style="list-style-type: none"> ▪ Avoided electric loss in T&D lines. 		<ul style="list-style-type: none"> ▪ Clean energy policies and programs that avoid energy consumption also avoid losses associated with transmission and distribution. 	3.2.1d

A range of basic and sophisticated methods is available to allow analysts to estimate how the electric system will be affected by clean energy measures, including when and where electricity generation may be offset. Basic methods typically include spreadsheet-based analyses or the adaptation of existing studies or information. Sophisticated methods typically use dynamic electric system models that (a) predict the response of energy generation to actions that influence the level of clean energy resources and (b) calculate the resulting

effects. These two approaches are not mutually exclusive, but may be used in a complementary way. Table 3.2.1 describes the advantages and disadvantages of each method and when they are appropriate to use.

SELECTING BENEFITS TO EVALUATE

Some states may not be interested in estimating all types of electric system benefits, or states may be considering programs that deliver benefits in only some areas. It is generally common practice to evaluate

TABLE 3.2.1 ADVANTAGES AND DISADVANTAGES OF BASIC VS. SOPHISTICATED METHODS OF ESTIMATING ELECTRIC SYSTEM BENEFITS

Advantages	Disadvantages	When to Use
Basic Estimation		
<ul style="list-style-type: none"> ▪ Relatively low cost. ▪ Requires minimal input data and time. 	<ul style="list-style-type: none"> ▪ Less robust. ▪ Provides approximate estimates. 	<ul style="list-style-type: none"> ▪ For preliminary studies. ▪ When time and/or budget are limited. ▪ When limited data resources are available.
Sophisticated Simulation		
<ul style="list-style-type: none"> ▪ Robust representation of electric system dispatch and, in some cases, capacity expansion. ▪ Provides high level of analytic rigor and detailed results. ▪ May be available from utility resource planners. ▪ May allow sensitivities to a wide range of assumptions. 	<ul style="list-style-type: none"> ▪ Time- and resource-intensive. ▪ Relatively high cost. ▪ Requires significant input data. ▪ Complex. ▪ Not transparent in stakeholder process. 	<ul style="list-style-type: none"> ▪ When a high degree of precision and analytic rigor is required. ▪ When sufficient data resources are available.

all the primary benefits for clean energy projects or programs. For secondary benefits, however, the need for detailed estimation can vary depending on several factors, including:

- The type of clean energy resource being considered,
- Regulatory or system operator study requirements,
- Available resources (e.g., computers, staff, and data), and
- Whether certain needs or deficiencies have been identified for the existing electric system.

For example, suppose a state is considering demand response resources such as direct load control (i.e., programs that enable electric providers to reduce the demand of consumer sites at peak times, sometimes by directly curtailing major energy-intensive equipment such as air conditioners and water heaters). For these types of measures, it is increasingly common to consider wholesale market price effects because the benefit to consumers from price reductions during peak hours can be substantial. On the other hand, if a state energy efficiency policy is expected to produce significant savings only during off-peak hours or seasons, which would result in a smaller impact on the wholesale market, it may not be worthwhile to estimate the wholesale

market price effects. Similarly, quantification of ancillary service benefits can be difficult in areas without regional transmission organizations (RTOs) that routinely report market prices, even if the clean energy resource has the capability of delivering these ancillary service benefits. In this case, analysts may decide to devote their limited staff and computing power to quantifying benefits that are likely to yield the most reliable and meaningful results, and address other benefits qualitatively.

There are a number of considerations in selecting which benefits to estimate. As indicated earlier, primary electric system benefits tend to be easier to quantify and the methods to quantify them tend to be mature. The methods to evaluate the secondary electric system benefits are more limited and can be subject to debate.

Tables 3.2.2 and 3.2.3 outline some of the factors that states can consider when deciding which electric system benefits to analyze, including available methods and examples, advantages, disadvantages, and purpose of analysis. Section 3.2.1, *How to Estimate the Primary Electric System Benefits of Clean Energy Resources*, and Section 3.2.2, *How to Estimate the Secondary Electric System Benefits of Clean Energy Resources*, review each type of benefit and explain the approaches generally used to analyze each benefit.

TABLE 3.2.2 PRIMARY ELECTRIC SYSTEM BENEFITS FROM CLEAN ENERGY MEASURES

Applicable Clean Energy Resources	Considerations for Determining Whether to Analyze	Who Usually Conducts Analysis?	When is Analysis Usually Conducted or Made Available?
BENEFIT: Avoided electricity generation or wholesale electricity purchases			
<ul style="list-style-type: none"> ▪ All resources. ▪ Resources that operate during peak hours. 	<ul style="list-style-type: none"> ▪ Traditionally analyzed in cost-benefit analysis. ▪ Widely accepted methods. ▪ Data generally available but expensive. ▪ Models available but are complex, not transparent, and are often expensive to use. ▪ Many assumptions about technology, costs, and operation needed. ▪ Long term fuel price forecasts must be purchased or developed. 	<ul style="list-style-type: none"> ▪ Utilities conduct in-depth modeling. ▪ PUCs and other stakeholders review utility’s results and/or conduct own analysis. ▪ RTO/ISO and the Independent Market Monitor. ▪ US EIA and private consultancies provide electric dispatch and capacity expansion forecasts. 	<ul style="list-style-type: none"> ▪ Resource planning and released regulatory proceedings. ▪ Area-specific DSM program development. ▪ RTO/ISO avoided cost estimates may be published on regular schedules.
BENEFIT: Avoided power plant capacity additions			
<ul style="list-style-type: none"> ▪ All resources. ▪ Resources that operate during peak hours. 	<ul style="list-style-type: none"> ▪ Traditionally analyzed in cost-benefit analysis. ▪ Generally accepted methods for both estimation and simulation. ▪ Some assumptions about technology, costs and operation needed. ▪ Data generally available. 	<ul style="list-style-type: none"> ▪ Utilities conduct in-depth modeling. ▪ PUCs and other stakeholders review utility’s results and/or conduct own analysis. ▪ In some regions, RTO/ISO publishes capacity clearing prices. 	<ul style="list-style-type: none"> ▪ Resource planning and proceedings. ▪ Area-specific DSM program development. ▪ RTO/ISO avoided cost estimates may be published on regular schedules.
BENEFIT: Deferred or avoided T&D capacity			
<ul style="list-style-type: none"> ▪ Resources that are close to load, especially those that operate during peak hours. 	<ul style="list-style-type: none"> ▪ Traditionally analyzed in cost-benefit analysis. ▪ Load flow forecast availability. ▪ Unit cost of T&D upgrades can be estimated but may be controversial. ▪ T&D capacity savings reasonably practical, but site-specific savings difficult to generalize. 	<ul style="list-style-type: none"> ▪ Utilities conduct in-depth modeling. ▪ PUCs and other stakeholders review utility’s results and/or conduct own analysis. ▪ RTO/ISO. 	<ul style="list-style-type: none"> ▪ T&D build planning. ▪ Area-specific DSM program development. ▪ RTO/ISO costs estimates may be published on regular schedules.
BENEFIT: Avoided energy loss during T&D			
<ul style="list-style-type: none"> ▪ Resources that are close to load, especially those that operate during peak hours . 	<ul style="list-style-type: none"> ▪ Traditionally analyzed in cost-benefit analysis. ▪ Straightforward; easy to estimate once avoided energy has been calculated ▪ Loss factor for peak savings may need to be estimated. 	<ul style="list-style-type: none"> ▪ Utilities collect loss data regularly and may conduct in-depth modeling. ▪ PUCs and other stakeholders review utility’s results and/or conduct own analysis. 	<ul style="list-style-type: none"> ▪ Resource planning and proceedings. ▪ Area-specific DSM program development.

TABLE 3.2.3 SECONDARY ELECTRIC SYSTEM BENEFITS FROM CLEAN ENERGY MEASURES

Applicable Clean Energy Resources	Considerations for Determining Whether to Analyze	Who Usually Conducts Analysis?	When is Analysis Usually Conducted?
BENEFIT: Avoided Ancillary Services			
<ul style="list-style-type: none"> ▪ Resources that can start during blackout, ramp up quickly, or provide reactive power. ▪ Resources closer to loads. 	<ul style="list-style-type: none"> ▪ Usually smaller benefits than traditionally analyzed benefits . ▪ Market price data available for some services in some markets (e.g., PJM). ▪ Ancillary service savings from clean resources often site-specific and difficult to estimate. ▪ Separating ancillary service value from capacity value in long run analysis may be difficult. 	<ul style="list-style-type: none"> ▪ Utilities conduct in-depth modeling. ▪ PUCs and other stakeholders review utility’s results and/or conduct own analysis. 	<ul style="list-style-type: none"> ▪ Resource planning and proceedings. ▪ Area-specific DSM program development.
BENEFIT: Wholesale Market Price Effects			
<ul style="list-style-type: none"> ▪ All clean resources . ▪ Resources that operate during peak hours. 	<ul style="list-style-type: none"> ▪ Benefits depend on market/pricing structure and peaking resources and forecasted reserve margins. ▪ Actual market price data generally available. ▪ Studies to estimate benefits may be complex. 	<ul style="list-style-type: none"> ▪ ISOs and utilities conduct in-depth modeling. ▪ PUCs, other stakeholders review utility’s results and/or conduct own analysis. 	<ul style="list-style-type: none"> ▪ Resource planning and proceedings. ▪ Area-specific DSM program development. ▪ Policy studies.
BENEFIT: Increased reliability and power quality			
<ul style="list-style-type: none"> ▪ Distributed resources. ▪ Resources close to load or with high power quality. ▪ All resources that operate as baseload units. ▪ All load reducing resources that increase surplus generating and T&D capacity in region. 	<ul style="list-style-type: none"> ▪ Historical reliability data often available. ▪ Historical power quality data rare. ▪ Studies for converting to dollar value complex and controversial. ▪ Benefits are especially valuable for manufacturing processes that are sensitive to power quality or regions where reliability is significant concern. 	<ul style="list-style-type: none"> ▪ Utilities conduct in-depth modeling . ▪ PUCs and other stakeholders review utility’s results and/or conduct own analysis. 	<ul style="list-style-type: none"> ▪ Usually ad hoc studies.
BENEFIT: Avoided or reduced risks of overbuilding (associated with long lead-time investments, such as the risk of overbuilding the electric system)			
<ul style="list-style-type: none"> ▪ Distributed resources with short lead times. ▪ Resources close to load ▪ All clean resources. 	<ul style="list-style-type: none"> ▪ Historical load and load variability data often available. ▪ Modeling varies from simple to complex. 	<ul style="list-style-type: none"> ▪ Utilities conduct in-depth modeling. ▪ PUCs and other stakeholders review utility’s results and/or conduct own analysis. ▪ Policy and risk management analysts. 	<ul style="list-style-type: none"> ▪ Resource planning and regulatory review of planning. ▪ Policy studies.

TABLE 3.2.3 SECONDARY ELECTRIC SYSTEM BENEFITS FROM CLEAN ENERGY MEASURES (cont.)

Applicable Clean Energy Resources	Considerations for Determining Whether to Analyze	Who Usually Conducts Analysis?	When is Analysis Usually Conducted?
BENEFIT: Avoided or reduced risks of stranded costs (from deferring investment in traditional, centralized resources until environmental and climate change policies are implemented)			
<ul style="list-style-type: none"> All clean energy resources. 	<ul style="list-style-type: none"> Modeling varies from simple to complex. Studies to estimate benefits may be complex. Regulatory uncertainty adds to complexity of analysis. 	<ul style="list-style-type: none"> Policy and risk management analysts. 	<ul style="list-style-type: none"> Resource planning and regulatory review of planning. Policy studies.
Fuel and technology diversification			
<ul style="list-style-type: none"> All clean energy resources. 	<ul style="list-style-type: none"> Diversity metrics computable from generally available data Portfolio analysis of costs vs. risks adds complexity. Must consider existing supply resources, not just incremental new resources. 	<ul style="list-style-type: none"> States. PUCs. Utilities. 	<ul style="list-style-type: none"> State energy plans. Resource planning.

3.2.1 HOW TO ESTIMATE THE PRIMARY ELECTRIC SYSTEM BENEFITS OF CLEAN ENERGY RESOURCES

Implementing clean energy policies and programs results in reduced demand for electricity. As described earlier, the primary electric system benefits resulting from this reduced demand include:

- Avoided cost of energy generation or wholesale energy purchases,
- Avoided cost of power plant capacity,
- Deferred or avoided T&D capacity costs, and
- Avoided energy loss during T&D.

States can compare different electric resources, including clean energy resources such as energy efficiency, renewable energy, clean distributed generation, or combined heat and power, by examining the net present value of the revenue requirements over the life of the resource. This enables comparison of various options on an equal basis, combining capital investments—accounting for carrying costs over the book life of the investment—with the discounted value of their annual fuel and operating costs over the investment’s operating life. For example, installing

high-efficiency transformers in a new substation can be more expensive than standard equipment in terms of up-front costs, but will waste less electricity over time, thereby reducing variable operating and maintenance costs. Likewise, replacing a chiller in a food-processing factory with a more efficient unit incurs a higher capital cost up-front, but reduces annual electricity costs for the customer.³ The basic concept is to compare the *net impact* on the cost of power over the lifetimes of each alternative that is technically capable of meeting the need. The alternative with the smallest net impact is typically the preferred choice, all other things being equal.

As indicated above, methods to quantify primary electric system benefits are mature and states can choose from a range of basic and sophisticated methods as described below.

³ Some states have competition in retail electricity service, others do not, and some are in a transitional state. These examples apply to both traditional, vertically integrated utilities and to distribution-only utilities. However, the existence of retail competition changes some of the details in important ways. One such difference is that under retail competition, a portion of the cost savings from lowering electric consumption accrues to the distribution utility (e.g., reduced need to expand T&D lines) and a portion becomes a reduction in the revenues of competitive wholesale generators. The policy implications of that split need to be considered, but the important point is that the entire savings accrues to the retail customers and to society as a whole.

Basic Methods

Basic methods span a broad range of possibilities, but generally rely on relatively simple relationships and analytic structures. Many are conceptually similar to sophisticated methods, but they use simplifying assumptions (proxy plants, system averages) rather than using detailed models to develop the impacts or parameters to estimate impacts (e.g., emissions factors).

For example, in order to estimate impacts of a clean energy resource, the goal is to match impacts (in terms of reduced demand for electricity) to the generation resource that will be displaced. However, instead of running a dispatch model to make these estimates, simple proxies—for generating units displaced, or emissions rates at the time of displacement—are used instead. A dispatch model would identify specifically those units on the margin in each time period, but with a basic method it may be sufficient to pair impacts (i.e., changes in generation requirements due to energy efficiency or other clean energy resources) to the general type of unit expected to be on the margin. For example, for all impacts during the peak period, a natural-gas-fired combustion turbine could be used to estimate impacts. During baseload periods, a coal plant could be used; while in shoulder periods an oil/gas steam might be used. The details would depend on the system being analyzed.

Estimation methods can be used for preliminary assessments or screening exercises, such as comparing the cost of a clean energy option with a previous projection of avoided costs or the cost of a proxy plant. Proxy plant assessments are typically done using cost assumptions for the expected next addition; for example, a natural gas combined cycle plant. Although they are less robust than modeling methods, basic methods require less data, time, and resources, so they can be useful when time, budget, and data are limited.

Sophisticated Methods

State-of-the-art power sector models for simulating and projecting power plant operations and costs (or T&D system adequacy) represent one type of sophisticated model. The sophisticated models have more complex structures and interactions than the basic approaches, and are designed to capture fundamental behavior of the sector using engineering-economic relationships or econometric approaches. They require additional input assumptions compared with basic methods, but add the ability to evaluate how the operations and capacity needs of the existing electric

grid will change with the adoption of a clean energy resource, based on engineering and economic fundamentals. Some models can predict energy prices, emissions, and other market conditions as well.

These models are complex to set up and can be costly. Developing a detailed representation of the electric system can involve many individual input assumptions, and it is important to validate, benchmark, or calibrate complex models against actual data. Access to confidential system data can also pose a challenge to conducting rigorous avoided cost analysis. However, in many cases datasets already exist for regional and utility planning analyses. Furthermore, existing sector models have the benefit of being well understood and mature.

While developing a full input data set for a dispatch simulation model can be a daunting task, it can provide a higher level of analytic rigor than basic estimation methods, which simplify complex systems and can result in errors in estimated costs. It is important to consider whether existing utility models can be relied on and are acceptable to stakeholders in a stakeholder process. If they can be relied on, the incremental work of estimating clean energy benefits will be greatly reduced.

Simulations of clean energy programs using sophisticated models can be done on an individual basis (e.g., modeling the impact of wind turbines) or the analysis can be used to assess multiple clean energy strategies. A single analysis of an affected system can provide a basis for analyses of a large number of clean energy programs simultaneously. For example, a sophisticated model may have the ability to assess the impact of an energy efficiency program and a renewable portfolio standard, capturing any interactions between the two. One of the benefits of more sophisticated approaches is their ability to capture these kinds of interactions.

The remainder of this section provides details about the methods available to assess the four primary electric systems benefits of clean energy.

3.2.1.a Avoided Costs of Electricity Generation or Wholesale Electricity Purchases

New clean energy resources (on the demand and supply side) avoid electricity and capacity costs in both the *short run* (e.g., three years or less) and in the *long run* (e.g., typically five to 20 years). In the short run, avoided costs consist of avoided fuel, variable operation and maintenance (O&M), and emissions allowances

that can be saved at those generating units that would operate less frequently as a result of new clean energy resource additions. Methods to estimate these short-run avoided costs are described in this section.

In the long run, however, avoided costs consist largely of the capital and operating costs associated with new generation capacity and T&D capacity that are displaced or deferred by clean energy resources.⁴ Methods to estimate these long-run costs are described in Section 3.2.1.b, *Avoided Costs of Power Plant Capacity*, and Section 3.2.1.c, *Avoided Transmission and Distribution Capacity*.

Key Considerations

A number of challenges arise when calculating short- and long-run avoided costs. Avoided cost estimates generally depend upon the comparison of two cases:

- A baseline or reference case without the new resource, and
- A case with the new resource, which in the case of a demand-side resource includes a reduction in the load or load decrement.

⁴ Sometimes the short-run and long-run effects of clean energy measures are referred to as “operating margin” and “build margin,” respectively (Biewald, 2005).

Short-run avoided costs of electricity generation are the operating costs of marginal units. Operating costs include fuel, variable O&M, and marginal emission costs. In a competitive market, wholesale energy prices will reflect the generator’s actual costs for operating marginal units in the bids they submit.

Consequently, both cases involve projections of future conditions and are subject to many uncertainties that influence electricity markets (e.g., fuel prices, construction costs, environmental regulations, and market responsiveness to prices). Since avoided costs are calculated as the difference between these two cases, they can be very sensitive to the underlying assumptions for either or both cases. This uncertainty is characteristic of long-run avoided cost calculations which require projections far out into an uncertain future. Therefore, states may want to consider performing sensitivity or scenario analyses on both the underlying base case (e.g., on demand growth, fuel prices) and on the key drivers of the case with the new resources (e.g., on the cost or timing of new resources) to gauge the potential range of results.

TABLE 3.2.4 COMPARISON OF BASIC AND SOPHISTICATED APPROACHES FOR QUANTIFYING AVOIDED COST OF ELECTRICITY GENERATION OR WHOLESALE ELECTRICITY PURCHASES

Example	Advantages	Drawbacks	When to Use This Method
Basic Method			
<ul style="list-style-type: none"> ▪ Proxy unit ▪ Futures prices ▪ Previously estimated cost projections 	<ul style="list-style-type: none"> ▪ Simple. ▪ May already be available. 	<ul style="list-style-type: none"> ▪ Combines energy & capacity. ▪ Not always relevant to a given policy if timing or costs are different. ▪ Limited horizon (futures). ▪ May miss interactive effects (fuel and emissions markets) and leakage effects for significant clean energy investments over time. 	<ul style="list-style-type: none"> ▪ When time, budget and data are limited. ▪ Rough estimates. ▪ Preliminary assessment. ▪ Overview-type policy assessment.
Sophisticated Method (Dispatch Modeling)			
<ul style="list-style-type: none"> ▪ ProMod ▪ Market Analytics ▪ MAPS ▪ IPM 	<ul style="list-style-type: none"> ▪ Robust representation of electrical system dispatch. 	<ul style="list-style-type: none"> ▪ Cost. ▪ Data- and time-intensive. ▪ Not transparent. 	<ul style="list-style-type: none"> ▪ When clean energy resource use will change system operations (e.g., clean energy resources change the marginal generating resource in a large number of hours).

Methods for Estimating Short-Run Avoided Costs of Electricity Generation or Wholesale Electricity Purchases

Two types of methods for quantifying short-run avoided costs of electricity generation or wholesale electricity purchases—basic and sophisticated—are described below. Both have advantages and limitations that are dictated by individual circumstances (see Table 3.2.4), and involve these steps as presented in Figure 3.2.1.

1. *Estimate clean energy operating characteristics.* Using the total energy impacts estimates (as described in Chapter 2), estimate the load impact or energy generation profile of the clean energy measure—an estimate of when the energy would be available—either on an hourly basis, or some other more aggregate time scale.
2. *Identify the marginal units to be displaced.* Identify the generation resources that would be displaced as a result of the clean energy resource, either due to reduced demand or increased supply of clean energy.
3. *Identify the characteristics of the marginal units displaced.* This specifically includes the avoided energy costs (and as described later, avoided emissions).
4. *Map the energy impacts to the displaced unit information.* This is done to calculate the short-run avoided costs of electricity generation. For basic methods, the estimated energy impacts (reduction in load or energy supplied) are mapped to the displaced energy information. For example, if hourly impacts are estimated, hourly kWh savings are multiplied by hourly avoided costs estimates. The summation of these hourly values represents the impact of the clean energy resource on costs. For sophisticated methods, this calculation may be a direct output of the modeling exercise.

The various approaches are described further below.

Basic Methods for Estimating Short-Run Avoided Costs

Short-run avoided costs of energy generation can be estimated using simplified methods, such as spreadsheet analysis of market prices, marginal cost data, or inspection of regional dispatch information (i.e., fuel mix and capacity factor by fuel type). Non-modeling

estimation methods, such as using a previously estimated avoided cost projection, may be more appropriate when time, budget, and access to data are limited, but they result in an approximation of the costs of avoided energy generation. Consequently, it is important for analysts to consider whether the estimation method is an acceptable representation of the actual system. For example, already-available avoided costs may be out of date or may not match the timing of the impacts of the clean energy resource being considered. The general steps involved in conducting these methods are described in more detail below.

Step 1: Estimate clean energy operating characteristics.

The first part of estimating avoided costs of clean energy is to estimate the amount of energy (in kWh) the clean energy measure is expected to generate or save over the course of a year and its lifetime. Methods for estimating this were described in Chapter 2.

In addition to estimating annual impacts, it may be desirable to estimate the timing of impacts within a year, either hourly or on some less frequent interval. Clean energy resources that reduce generation requirements at the time of peak, when combustion turbines may be operating, will differ from those that affect the system during periods of low demand when oil/gas steam plants or coal plants may be operating.

In the case of energy efficiency measures, load impact profiles describe the hourly changes in end-use demand resulting from the program or measure. In the case of energy resources, the generation profiles (for wind or PV, for example) are required. The time period can range from 8,760 hourly intervals to two or three intervals, such as peak, off-peak, and shoulder periods. Similarly, a wind turbine can be expected to produce differing quantities of electricity across the day and year. These data are used to identify more precisely what specific generation or generation types are displaced by the clean energy resources.

Several sources are available to help predict the load profiles of different kinds of renewable energy and energy efficiency projects:

- Performance data for renewable technologies are available from the National Renewable Energy Laboratory (NREL), as well as universities and other organizations that promote or conduct research on the applications of renewable energy. For example, the Massachusetts Institute of Technology's Analysis Group for Regional Energy Alternatives

FIGURE 3.2.1 STEPS FOR ESTIMATING AVOIDED COST

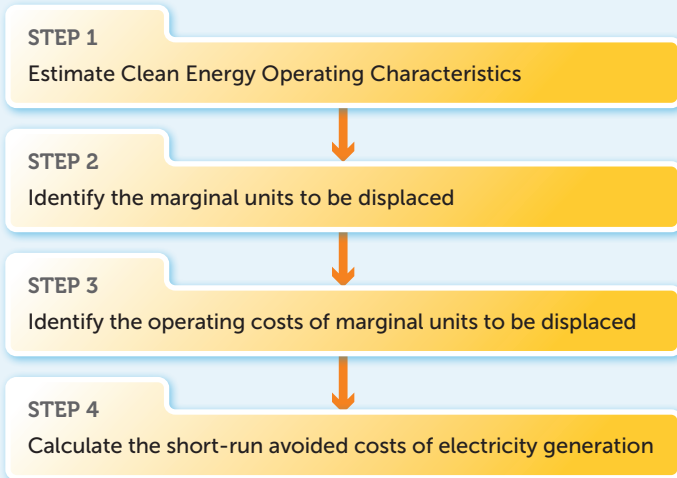

and Laboratory For Energy and the Environment published a report in 2004 entitled Assessment of Emissions Reductions from Photovoltaic Power Systems (http://web.mit.edu/agrea/docs/MIT-LFEE_2004-003a_ES.pdf). Another useful source is the Connecticut Energy Conservation Management Board (<http://www.ctsavesenergy.org/ecmb/index.php>).

- The California Database for Energy Efficient Resources (DEER) provides estimates of energy and peak demand savings values, measure costs, and effective useful life of efficiency measures (<http://www.energy.ca.gov/deer/>).
- Some states or regions have technology production profiles in their efficiency and renewable energy potential studies (e.g., NYSERDA's report, Energy Efficiency and Renewable Energy Resource Development Potential in New York State, 2003, available at <http://www.nyserda.org/sep/EE&ERpotentialVolume1.pdf>).
- Load impact profile data for energy efficiency measures may be available for purchase from various vendors, but typically is not publicly available in any comprehensive manner.
- Wind profiles can be obtained from a number of sources, including the Department of Energy's NEMS model (<http://www.eia.doe.gov/oiaf/aeo/overview/>), NREL (www.nrel.gov), the American Wind Energy Association (www.awea.org), and

several research organizations that have published information on wind resources in specific locations. All data will likely require some extrapolation or transposition for the intended use.

In the absence of specific data on the load impact or energy profile of the clean energy resource, analysts will need to use their judgment to assess the timing of that resource's impacts.

Step 2: Identify the marginal units to be displaced.

The next step is to identify the units and their associated costs that are likely to be displaced by the clean energy resources. While this section discusses the process of estimating avoided cost benefits, these same methods support the estimation of emissions benefits of clean energy.

In each hour, electric generating resources are dispatched from least to most expensive, on a variable cost basis, until demand is satisfied. There are a host of complexities involved in dispatching the generating system, including generator start-up and shut-down operating constraints and costs, and transmission and reliability considerations, among other factors. However, in concept, the unit that is displaced is the last unit to be dispatched. Estimating the benefits of clean energy resources requires identifying this "marginal" unit and its avoided costs. Because reported or modeled avoided costs may not reflect some of the other complexities identified above, simply looking at variable fuel and O&M may be misleading. However, basic approaches using system averages, time-dependent methods, displacement curves, and load dispatch curve analysis can give reasonable estimates of the impacts of clean energy.

System Averages

The simplest approach to estimating the impacts of the displaced unit, absent any detailed information on the system, is to use the average generating unit as a proxy. Some studies have used this approach. The average system costs and the average emissions characteristics can be used to estimate impacts; however, most analysts recognize that some types of generating units are almost never on the margin and therefore should not be included in the characterization of the marginal unit. For example, nuclear units, hydropower, and renewable resources are very rarely on the margin and unlikely to be displaced by clean energy sources in the short run. Moreover, the average cost of generation can differ greatly from the marginal source of generation.

In response to this observation, one approach sometimes used is to characterize the remaining units—specifically, the fossil units—as a representation of the average marginal unit. This is an improvement over the system average, but still does not capture the potential impact of a variety of clean energy resources, each with differing impact patterns. For example, in many regions of the country coal units are on the margin only a small number of hours during the year. Thus, using a fossil average may understate cost savings and overstate emissions impacts of the clean energy resource. Despite these limitations, absent any detailed information on the impact of the resource or the nature of the marginal generation, this approach is an option.

Time Dependent Methods

Another method to estimate the impacts of clean energy resources, including effects on costs and emissions, is to identify those resources that are expected to be displaced depending on the time the clean energy impacts occur. The most detailed approach is to identify the marginal generating unit on an hourly basis. Clean energy impacts (in kWh) can then be mapped (using the time of impact estimates described above) to the appropriate marginal generation source. Costs savings (and emissions impacts) can then be estimated.

Time-dependent methods do not need to be on an hourly basis; several less data-intensive basic approaches (displacement curves and load curve analysis) are available and described below:

Displacement Curves

Another approach to estimating what will be displaced by clean energy involves displacement curves. Baseload plants operate all of the time throughout the year because their operating costs are low and because they are typically not suitable for responding to the many fluctuations in load that occur throughout the day. As a result, they would not be expected to be displaced with any frequency. These plants would have high capacity factors (e.g., greater than 0.8). Capacity factor is the ratio of how much electricity a plant produces to how much it could produce, running at full capacity, over a given time period. *Load-following* plants, in contrast to baseload plants, can quickly change output, have much lower capacity factors (e.g., less than 0.3) and are more likely to be displaced.

A displacement curve can be developed to identify what generation is likely to be displaced. The curve would reflect the likelihood of a unit being displaced,

FIGURE 3.2.2 DISPLACEMENT CURVE BASED ON CAPACITY FACTOR

Sample curve for relating displacement to capacity factor

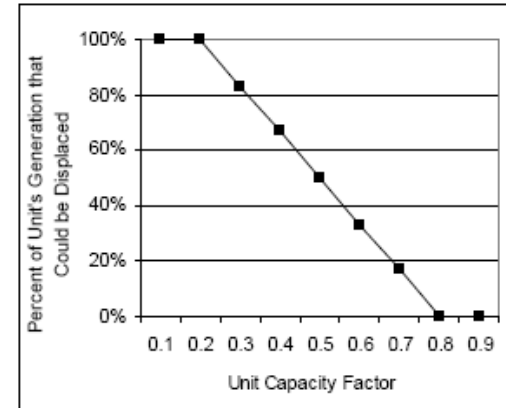

Source: Keith and Biewald, 2005.

based on a proxy for its place in the dispatch order. A reasonable proxy for the likelihood of a generating unit to be displaced by a clean energy measure is the unit's capacity factor. Figure 3.2.2 illustrates this concept using capacity factor as a proxy. Baseload plants on the right side of the curve, such as nuclear units, are assumed to be very unlikely to be displaced; peak load plants on the left, such as combustion turbines, are much more likely to be displaced. These capacity factor estimates can be based on an analysis of actual dispatch data, modeling results, or judgment. Historic data on, or estimates of, capacity factors for individual plants are available from EPA's eGRID database (<http://www.epa.gov/cleanenergy/energy-resources/egrid/index.html>).

It is important to note that a displacement curve may not capture some aspects of electric system operations. For example, an extended outage at a baseload unit (for scheduled maintenance or unanticipated repairs) would increase the use of load-following and peaking units, affecting the change in net emissions from the clean energy project. According to the displacement curve, this plant would be more likely to be displaced, even though it would rarely if ever be on the margin. The relationship between capacity factor and percent of time it will be displaced could be determined analytically (e.g., examining historical data on the relationship between a unit's capacity factor and the time it is on the margin. More likely a judgment could be made about this relationship. Other proxies could serve to develop this curve, including unit type (e.g., coal steam,

nuclear, combustion turbine), heat rate, or pollution control equipment in place.

Load Curve Analysis

In general, generating units are dispatched in a predictable order that reflects the demand on the system and the cost and operational characteristics of each unit. These plant data can be assembled into a generation “stack,” with lowest marginal cost units on the bottom and highest on the top. A dispatch curve analysis matches each load level with the corresponding marginal supply (or type of marginal supply). Table 3.2.5, *Hypothetical Load for One-Week Period*, and Figure 3.2.3, a hypothetical dispatch curve representing 168 hours by generation unit, ranked by load level, provide a combined example of a dispatch curve that represents 168 hours (a one-week period) during which a hypothetical clean energy resource would be operating.

Table 3.2.5 illustrates this process for a one-week period. There are 10 generating units in this hypothetical power system, labeled 1 through 10. Column [3] shows the number of hours that each unit is on the margin.

In many cases, dispatch curves are available from the local power authorities and Load Balancing Authorities [e.g., a regional Independent System Operator (ISO)]. If this information is not available, states can attempt to construct their own analysis.

Constructing a dispatch curve requires data on:

- Historical utilization of all generating units in the region of interest;
- Operating costs and emission rates (to support emissions estimation, as described in Chapter 4) of the specific generating units, for the most disaggregate time frame available (e.g., seasonally, monthly);
- Energy transfers between the control areas of the region and outside the region of interest (because the marginal resource may be coming from outside the region); and
- Hourly regional loads.

Operating cost and historical utilization data can typically be obtained from the EIA (<http://www.eia.doe.gov/cneaf/electricity/page/data.html>) or the local Load Balancing Authority.⁵ When generator cost data

FIGURE 3.2.3 A HYPOTHETICAL LOAD DURATION/DISPATCH CURVE REPRESENTING 168 HOURS (shown in half-day increments) by generation unit, ranked by load level

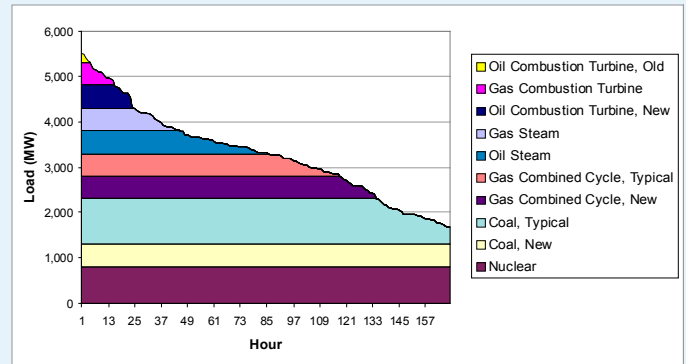

Source: Developed by Synapse Energy, unpublished, 2007.

TABLE 3.2.5 HYPOTHETICAL LOAD FOR ONE-WEEK PERIOD: HOURS ON MARGIN AND EMISSION RATE

[1]	[2]	[3]
Unit	Unit name	Hours on margin
1	Oil Combustion Turbine, Old	5
2	Gas Combustion Turbine	10
3	Oil Combustion Turbine, New	9
4	Gas Steam	21
5	Oil Steam	40
6	Gas Combined Cycle, Typical	32
7	Gas Combined Cycle, New	17
8	Coal, Typical	34
9	Coal, New	0
10	Nuclear	0

Weighted average, SO₂ emissions (lbs/MWh): 5.59

⁵ Often these sources can also provide generator-specific emission rates for estimating potential emission reductions from clean energy.

are not available, capacity factors (from the eGRID database, for example, as described above) for traditional generating units can be used to approximate the relative cost of the unit (those with the highest capacity factors are assumed to have the lowest cost). As an exception, variable power resources such as wind and hydropower are assumed to have lower costs than fossil fuel or nuclear units.

Operational data (or simplifying assumptions) regarding energy transfers between the control areas of the region and hourly regional loads can be obtained from the ISO or other Load Balancing Authority within the state's region.

Dispatch curve analysis is commonly used in planning and regulatory studies. It has the advantage of incorporating elements of how generation is actually dispatched while retaining the simplicity and transparency associated with non-modeling methods. However, this method can become labor-intensive relative to other non-modeling methods for estimating displaced emissions if data for constructing the dispatch curve are not readily available. Another disadvantage is that it is based on the assumption that only one unit will be on the margin at any given time; this generally is not true in most regions.

Methods described earlier, such as displacement curves, can support the development of a simplified dispatch curve. For example, capacity factors can be used to “fill” the horizontal segments on the curve as shown in Figure 3.2.3. One can assume that units with capacity factors greater than 80 percent can fill the baseload segments and that peaking units, with the lowest capacity factors, would fill the peak segments. Units with capacity factors between 80 and 60 percent would fill the next slice of the dispatch curve, and so on. The resolution would reflect available data or the ability to develop meaningful assumptions. The hope is that the level of aggregation is such that the units' characteristics are generally similar and as such the marginal unit would be approximated by the group average. If data allows, it is possible to take into account differences in units that drive their costs and emissions (e.g., general unit type and burner type, the presence of pollution control equipment, unit size, fuel type).

Step 3: Identify the operating costs of marginal units to be displaced. This process varies depending on whether the market is regulated or restructured.

In regulated markets, short-run avoided energy costs typically include fuel costs, a variable O&M cost, and marginal emissions costs for the highest-cost generator in a given hour. Data sources for control area hourly marginal costs include the U.S. Federal Regulatory Commission (FERC) form 714 (<http://www.ferc.gov/docs-filing/eforms/form-714/overview.asp>).

In restructured markets, where RTOs administer regional wholesale power markets, economic dispatch is conducted on the basis of bid prices rather than generators' marginal costs (theoretically equivalent to the marginal cost). This information is available at each ISO's Web site (see *Information Resources* at the end of this chapter for the Web sites of individual ISOs).

For longer-term analysis it is necessary to forecast cost increases. Historical hourly operating costs for the marginal unit (i.e., regulated markets) or market prices (i.e., restructured markets) can be escalated using forward market electricity prices, though the forecast time frame is limited. Forward electricity prices are available from energy traders and industry journals such as Platt's MegaWatt Daily (<http://www.platts.com/Electric%20Power/Newsletters%20&%20Megawatt%20Daily/>).

Step 4: Calculate the short-run avoided costs of electricity generation. For each hour or time of use period, multiply the cost of the marginal unit or hourly energy market price by the reduction in load (for demand-side resources) or the increase in generation (for supply-side resources), as estimated using techniques described in Chapter 2. Typically, avoided costs are expressed as the annual sum of these avoided costs for each hour or other time period.

The *Estimating Short-Run Avoided Cost* text box illustrates how all four steps can be used to estimate short-run avoided costs.

Key Considerations

These basic methods have some limitations that should be considered when choosing an approach:

- Methods that rely on historical data are limited to replicating what occurred in the past. Substantial changes in costs or performance of generation, or other restrictions on their operations (e.g., climate legislation, requirements for a renewable portfolio standard) could fundamentally change the operation of the system and the implied dispatch curve.

Estimating Short-Run Avoided Cost

To illustrate the described approach for estimating short-run avoided costs, consider the case of a state that wishes to evaluate the potential benefits of an energy efficiency program. Sample calculations are illustrated in the accompanying table.

Step 1: The state estimates that the energy efficiency program would reduce electricity demand as shown in the *Avoided Electricity* column (based on an analysis of annual savings from the typical system and a typical load shape).

Step 2: Using a load curve analysis, the state estimates that natural gas combustion turbines are typically on the margin during peak periods for both summer and winter, a mix of natural gas combined cycle units and natural gas-fired steam units (about 50% of each) are on the margin during shoulder periods, and existing coal-fired generators (pulverized coal) are typically on the margin during the off-peak periods.

SAMPLE CALCULATION OF SHORT-RUN ENERGY AVOIDED COSTS

Time Period	Avoided Electricity (MWh)	Avoided Energy Cost for Time Period (\$/kWh)	Total Avoided Energy Cost (\$)
Summer Peak (912 hours)	123,120	0.08	9,234,000
Summer Shoulder (1368 hours)	153,900	0.06	8,772,300
Summer Off-Peak (1368 hours)	20,520	0.03	513,000
Winter Peak (1278 hours)	115,020	0.07	8,051,400
Winter Shoulder (1917 hours)	143,775	0.06	8,195,175
Winter Off-Peak (1917 hours)	19,170	0.03	479,250
Total	575,505		35,245,125

Step 3: The avoided costs associated with each of these marginal generating technologies are estimated based on typical variable operating and fuel costs for those types of units estimated to be on the margin. The results are shown in the *Avoided Energy Cost for Time Period* column.

Step 4: The *Total Avoided Energy Cost* column shows the result of multiplying the *Avoided Electricity* column by the *Avoided Energy Cost for Time Period* column. Summing across all periods yields the expected avoided costs for one year.

► Even without such fundamental changes, the system changes over time as new units are added, existing units are retired, and units shift in dispatch order. Analyses based on historical data do not capture these shifts, so to the extent that estimates are being developed for the future these types of basic methods must be used with caution.

- These methods may not adequately address the issue of leakage—in which increases in clean energy result in reductions in generation outside the region of interest (e.g., in another state or region)—if these transactions are not explicitly accounted for in the analysis.

Sophisticated Methods for Estimating Short-Run Avoided Costs: Dispatch Modeling

Sophisticated simulation modeling, such as electric dispatch modeling, requires developing a detailed representation of the electric system with many individual input assumptions. While developing a full input data set for a dispatch simulation model can be a resource-intensive task, the output from a simulation model can provide more valid estimates than a basic approach,

especially for clean energy resources with more availability at certain times and for projections of clean energy impacts in the future. Dispatch models can also be employed to develop parameters that can be used to estimate the impacts of a large range of clean energy resources. For example, multiple model runs can be performed estimating impacts of changes in generation requirements at certain seasons and times of day (e.g., winter peak, summer peak, winter base, etc.). These parameters, such as the marginal emission rate and avoided costs, can be applied to estimates of the impacts of clean energy resources at those same times.

Dispatch models simulate the dynamic operation of the electric system given the characteristics of specific generating units and system transmission constraints. They typically do not predict how the electric system will evolve but instead can indicate how the existing electric sector will respond to a particular clean energy policy or measure. This is appropriate in the short run when the electric system is more likely to react than to evolve due to clean energy measures. Dispatch models specifically replicate least-cost system dispatch and can be used to determine which generating units are dis-

NEW YORK ENERGY \$SMARTSM PROGRAM COST EFFECTIVENESS ASSESSMENT

The New York State Energy Research and Development Authority (NYSERDA) periodically evaluates the cost-effectiveness (using a benefit-cost ratio) of New York Energy \$Smart energy efficiency programs. NYSEDA uses a production costing model, MAPS, to forecast the avoided energy and capacity benefits of the programs for several years. Avoided energy costs are forecasted by applying MAPS escalation rates to the weighted average energy price by location and time period. The weighted average energy prices are based on historical hourly NYISO day-ahead market data for January 2000 through December 2004. The avoided capacity costs are forecasted by applying the same escalation rates to NYISO monthly capacity data by location and time period.

Source: Heschong Mahone Group, Inc., 2005.

placed and when they are displaced based on economic and operating constraints.

Hourly dispatch modeling is generally used for near-term, highly detailed estimations. This approach is appropriate for financial evaluations of specific projects, short-term planning, and regulatory proceedings. Sensitivity cases can be run to explore the range of possible impact values. While this type of modeling is generally seen as very credible in these contexts, it often lacks transparency. For example, dispatch models vary in terms of how they treat outage rates, heat rates, bidding strategies, transmission constraints, and reserve margins. Underlying assumptions about these factors may not be apparent to the user. Moreover, labor and data needs are extensive. Software license and labor costs can be prohibitively high for many agencies and stakeholders, who often must rely on the results of dispatch modeling conducted by utilities and their consultants for regulatory proceedings.

Generally, this method involves modeling electricity dispatch with and without the new resource, on an hourly basis, for one to three years into the future. As with basic estimation methods, it is essential to establish the specific operational profile of the clean energy resource. Alternatively, an hourly dispatch model can be used to determine hourly marginal costs and emission rates (lbs/kWh), which can then be aggregated by time period and applied to a range of clean energy resources according to their production characteristics. Some models, described later in this chapter, simulate both capacity planning and dispatch, although they may have a simpler representation of dispatch (e.g.,

seasonally, with multiple load segments). These models are applied similarly to models that strictly address dispatch, but offer the ability to capture the differing marginal resources over load levels and time.

Tools

There are several dispatch models available for states to use:

- *EnerPrise Market Analytics* (powered by PROSYM) supported by Ventyx®.

A chronological electric power production costing simulation computer software package, PROSYM is designed for performing planning and operational studies. As a result of its chronological nature, PROSYM accommodates detailed hour-by-hour investigation of the operations of electric utilities. Inputs into the model are fuel costs, variable operation and maintenance costs, and startup costs. Output is available by regions, by plants, and by plant types. The model includes a pollution emission subroutine that estimates emissions with each scenario. <http://www1.ventyx.com/analytics/market-analytics.asp>

- *Multi-Area Production Simulation (MAPS™)* developed and supported by GE Energy and supported by other contractors.

A chronological model that contains detailed representation of generation and transmission systems, MAPS can be used to study the impact on total system emissions that result from the addition of new generation. MAPS software integrates highly detailed representations of a system's load, generation, and transmission into a single simulation. This enables calculation of hourly production costs in light of the constraints imposed by the transmission system on the economic dispatch of generation. http://www.gpower.com/prod_serv/products/utility_software/en/ge_maps/index.htm

- *Plexos for Power Systems™* owned by Energy Exemplar.

A simulation tool that uses LP/MIP (Linear Programming/Mixed Integer Programming) optimization technology to analyze the power market, Plexos contains production cost and emissions modeling, transmission modeling, pricing modeling, and competitiveness modeling. The tool can be used to evaluate a single plant or the entire power system. <http://www.energyexemplar.com>

- *PowerBase Suite*™ (including PROMOD IV®) supported by Ventyx.

A detailed generator and portfolio modeling system, with nodal locational marginal pricing forecasting and transmission analysis, PROMOD IV can incorporate extensive details in generating unit operating characteristics and constraints, transmission constraints, generation analysis, unit commitment/operation conditions, and market system operations. <http://www1.ventyx.com/analytics/promod.asp>

3.2.1.b Avoided Costs of Power Plant Capacity

While the avoided cost of energy generation is the major short-run benefit, avoided costs of power plant capacity in the long run can be significant and should be included in resource decisions.⁶ For example, in the short run, surplus centralized generation capacity that is freed up by clean energy policies and programs can be sold to other utilities in the region for meeting their capacity needs. These costs are based on the levelized⁷

⁶ For more information about establishing energy efficiency as a high priority resource in long run planning, see *National Action Plan for Energy Efficiency Vision for 2025: A Framework for Change*, November 2008. <http://www.epa.gov/cleanenergy/energy-programs/napee/resources/vision2025.html>.

⁷ The present value of capital costs, levelized in real dollars to remove the effect of inflation.

capital costs of peaking capacity (e.g., a combustion turbine) or on the market price for peaking capacity. This is a critical factor in competitive wholesale markets. Over the long run, however, new clean energy initiatives typically avoid or defer both the cost of building new power plants and the cost of operating them. These are the avoided costs of power plant capacity that can be estimated using either basic estimation or sophisticated simulation approaches.⁸ Both have advantages and limitations, as described in Table 3.2.6.

Basic Methods for Estimating Avoided Costs of Power Plant Capacity

Basic estimation methods involve the use of tools such as spreadsheets to estimate any long-run avoided costs of power plant capacity that may result due to a clean energy measure under consideration. One method commonly used is the proxy plant approach. This approach involves estimating the avoided cost of a power plant that might be built in the future. Energy cost estimates (as described above) would reflect this plant's dispatch costs for future estimates and the capital costs. Depending on future expectations of capital costs, fuel prices, and environmental requirements, either a

⁸ For information about how utilities estimate avoided costs, see *The Guide to Resource Planning with Energy Efficiency: A Resource of the National Action Plan for Energy Efficiency*, November 2007, www.epa.gov/cleanenergy/documents/resource_planning.pdf, or *Costing Energy Resource Options: An Avoided Cost Handbook for Electric Utilities* (Tellus Institute, 1995).

TABLE 3.2.6. COMPARISON OF BASIC AND SOPHISTICATED APPROACHES FOR QUANTIFYING AVOIDED COSTS OF POWER PLANT CAPACITY

Example	Advantages	Drawbacks	When To Use This Method
Basic approach			
<ul style="list-style-type: none"> ▪ Peaker construction cost. ▪ See also above for combined capacity & energy estimate. 	<ul style="list-style-type: none"> ▪ Simple. ▪ May already be available. 	<ul style="list-style-type: none"> ▪ Peaker methodology does not reflect opportunities to displace baseload in the long run. 	<ul style="list-style-type: none"> ▪ Rough estimates. ▪ Preliminary screening of demand response resources. ▪ Overview-type policy assessments.
Sophisticated approach			
<ul style="list-style-type: none"> ▪ Capacity Expansion/Ventyx. ▪ <i>PowerBase Suite</i>. ▪ <i>IPM</i>. 	<ul style="list-style-type: none"> ▪ Robust representation of electrical system operation. 	<ul style="list-style-type: none"> ▪ Cost. ▪ Data- and time-intensive. ▪ Not transparent. 	<ul style="list-style-type: none"> ▪ When clean energy resource use will change system operations (e.g., clean energy resources change the marginal generating resource in a large number of hours).

ELECTRIC ENERGY EFFICIENCY AND RENEWABLE ENERGY IN NEW ENGLAND: THE OTC WORKBOOK

An analysis conducted by the Regulatory Assistance Project (RAP) explains how energy efficiency and renewable energy have led to many positive effects on the general economy, the environment, and energy security in New England while also quantifying these effects in several new ways. The report assesses the air quality effects of efficiency and renewable investments using the OTC Workbook tool. The analysis finds that there is clear progress in reducing CO₂ emissions from the deployment of energy efficiency and renewable energy. The projections by the OTC Workbook indicate that due to current energy efficiency programs, 22.5 million tons of CO₂ emissions are avoided from 2000–2010.

Source: *The Regulatory Assistance Project*. <http://www.raponline.org/Pubs/RSWS-EEandREinNE.pdf>

combined cycle combustion turbine or a new advanced coal plant may be used as the proxy plant to represent the long-run avoided costs of energy and capacity of clean energy initiatives.

Data required for this method include:

- Cost and performance information for the proxy plant; and
- Capital cost escalation rates, a discount rate, and other financial data.

Utilities are one possible source of these data and often provide this information to public utility commissions in resource planning and plant acquisition proceedings. Other data sources include:

- *Regional transmission organizations, independent system operators, and power pools*. These sources maintain supply and demand projections by region and often sub-region.
- *The U.S. Energy Information Administration (EIA) Annual Energy Outlook*. This resource provides long-term projections of fuel prices and electricity supply and demand. In addition, some states and regions develop their own forecasts of electricity demand, fuel prices, and other variables. <http://www.eia.doe.gov/oiaf/aeo/>
- *Regional reliability organizations*. These organizations can provide information on required reserve margins.

A RESOURCE FOR CALCULATED AVOIDED EMISSIONS: THE MODEL ENERGY EFFICIENCY PROGRAM IMPACT EVALUATION GUIDE

The Model Energy Efficiency Program Impact Evaluation Guide provides guidance on model approaches for calculating energy, demand, and emissions savings resulting from energy efficiency programs. The Guide is provided to assist in the implementation of the National Action Plan for Energy Efficiency's five key policy recommendations and its Vision of achieving all cost-effective energy efficiency by 2025. Chapter 6 of the report presents several methods for calculating both direct onsite avoided emissions and reductions from grid-connected electric generating units. The chapter also discusses considerations for selecting a calculation approach (NAPEE, 2007).

- *The Bureau of Economic Analysis (BEA)*. The BEA provides information on economic forecasts. The BEA releases measures of inflation (e.g., the Gross Domestic Product Implicit Price Deflator), which are available on its Web site <http://www.bea.gov/national/index.htm#gdp>
- *The Securities and Exchange Commission (SEC) and the Federal Energy Regulatory Commission (FERC)*. Individual utility historical financial data are available in annual reports and other utility filings with the SEC and FERC. Utilities file annual 10-K and quarterly 10-Q company reports with the SEC. These data are available from the SEC EDGAR system at <http://www.sec.gov/edgar.shtml>. Utilities also file FERC Form 1, which is available from FERC at <http://www.ferc.gov/docs-filing/eforms/form-1/viewer-instruct.asp>. They can also be retrieved from the eLibrary at <http://www.ferc.gov/docs-filing/elibrary.asp>.

Using data on initial construction costs, fixed and variable operating costs, and financial data, a discounted cash flow analysis can be conducted. Once estimated, the net present value of the cost of owning the unit that reflects the full carrying costs of the new unit (including interest during construction, debt servicing, property taxes, insurance, depreciation, and return to equity holders) can be converted to annualized costs (in \$/kW-year). The annual capital costs (\$/kW-year) can be multiplied by the annual capacity savings from the technology to estimate the avoided capital costs. The load profile information (reductions in demand at peak hours), discussed earlier would provide an estimate of displaced capacity, or simpler estimates can be used.

Sophisticated Methods for Estimating Avoided Costs of Power Plant Capacity: Capacity Expansion Models

Sophisticated simulation methods, such as capacity expansion models (also called system planning models), can be used to quantify the long-run avoided capacity costs that result from implementing clean energy measures. Capacity expansion models predict how the electric system will evolve over time, including what capacity will be added through the construction of new generating units and what units will be retired, in response to changes in demand and prices. This method involves allowing the model to predict what will likely happen to the resource mix based on costs of new technology, growth, existing fleet of generating assets, environmental regulations (current and planned), and considering dispatch both with and without the new clean energy resource. Capacity expansion models are typically used for longer-term studies (e.g., five to 20 years), where the impacts are dominated by long-term investment and retirement decisions. They are also typically used to evaluate large geographic areas.

Using capacity expansion models to estimate the avoided costs of power plant capacity typically involves the steps described below.

Step 1: Generate a business-as-usual forecast of load and how it will be met. Some capacity expansion models use existing generating plants and purchase contracts to serve the load over the forecast period, and the model (or the modeler) adds new generic plants when those resources do not meet the load forecast. The type of plants added depends on their capital and operating costs, as well as the daily and seasonal time-pattern of the need for power determined using discounted cash flow analysis as described earlier. The model repeats this process until the load is served through the end of the forecast period and a least-cost solution is found. This base case contains a detailed schedule of resource additions that becomes the benchmark capital and operating costs over the planning period for later use in the long-run avoided cost calculation.

Step 2: Include the clean energy resource over the planning period and create an alternate forecast. The following two approaches can be used to incorporate the clean energy resource into the second projection:

- For a more precise estimate of the savings from a clean energy program, reduce the load forecast year by year and hour by hour to capture the

Capacity Expansion Modeling involves three steps:

1. Generate a BAU forecast of load, and how load will be met without the clean energy resources;
2. Create an alternate forecast that includes the clean energy resources over the planning period to show how load is expected to be met.
3. Calculate the avoided costs of power plant capacity.

impact of energy efficiency resources, based on the program design and estimates of its energy and capacity savings, or add renewable resources as an available supply. This method would capture the unique load shape of the clean energy resource.

- For a less rigorous estimate (e.g., to use in screening candidate clean energy policies and programs during program design), reduce the load forecast by a fixed amount in each year, proportionally to load level. This method does not capture the unique load shape or generation supply of the clean energy resource.
- For renewable resources, add the resource to the supply mix (or for some models and non-dispatchable resources, renewable energy could be netted from load in the same manner as is done for energy efficiency).

In both the precise and less rigorous methods described above, the difference in the projected capital and operating cost over the planning period of the two cases is the avoided capacity cost to use in analyzing the clean energy resource. If a per unit avoided cost, such as the avoided cost per MWh, is needed for screening clean energy resources or other purposes, it may be computed by taking the avoided cost (i.e., the difference between the cost in the two cases) for the relevant time period (e.g., a given year) and dividing that by the difference in load between the two cases.

Step 3: Calculate the avoided costs of power plant capacity. The difference between the costs in the two projections above represents the annualized or net present value costs that would be avoided by the clean energy resource.

Capacity expansion or system planning models can examine potential long-term impacts on the electric sector or upon the entire energy system—in contrast to the dispatch models used to assess the avoided costs

of energy generation, which focus on only the electric sector. Capacity expansion models that can examine the potential impacts of programs upon the entire energy system are generally used for projecting scenarios of how the energy system will adapt to changes in supply and demand or to new policies including emissions controls. They take into account the complex interactions and feedbacks that occur within the entire energy system (e.g., fuels and emissions markets), rather than focusing solely upon the electric sector impacts. This is important because there are tradeoffs at the system level in the technological and economic feasibility of fuels and technologies that may not be captured by a model that focuses solely on a particular aspect of the electric system. In addition to capturing the numerous interactions, energy system capacity expansion models can also model dispatch, although often not in a chronologic, 8760-hour dispatch.⁹

Tools: Electric Sector-only Capacity Expansion Models

Commonly used electric sector-only capacity expansion models for calculating long-run avoided costs of power plant capacity include:

- *IPM*[®] developed and supported by ICF International.

This model simultaneously models electric power, fuel, and environmental markets associated with electric production. It is a capacity expansion and system dispatch model. Dispatch is based on seasonal, segmented load duration curves, as defined by the user. IPM also has the capability to model environmental market mechanisms such as emission caps, trading, and banking. System dispatch and boiler and fuel-specific emission factors determine projected emissions. IPM can be used to model the impacts of clean energy resources on the electric sector in the short and long term. <http://www.icfi.com/Markets/Energy/energy-modeling.asp#2>

- *PowerBase Suite* (including *Strategist*[®]) supported by Ventyx.

Strategist is composed of multiple application modules incorporating all aspects of utility planning and operations. This includes forecasted load modeling; marketing and conservation programs; production cost calculations including the dispatch of energy

resources; optimization of future decisions; non-production-related cost recovery (e.g., construction expenditures, AFUDC, and property taxes); full pro-forma financial statements; and rate design. <http://www1.ventyx.com/analytics/strategist.asp>

Tools: Whole Energy–Economy System Planning Models

Energy system-wide models with electricity sector capacity expansion capability include:

- *U.S. DOE National Energy Modeling System (NEMS)* is a system-wide energy model that represents the behavior of energy markets and their interactions with the U.S. economy. The model achieves a supply/demand balance in the end-use demand regions, defined as the nine Census divisions, by solving for the prices of each energy product that will balance the quantities producers are willing to supply with the quantities consumers wish to consume. The system reflects market economics, industry structure, and existing energy policies and regulations that influence market behavior. The Electric Market Model, a module within NEMS, forecasts the actions of the electric power sector over a 25 year time frame and is an optimization framework. NEMS is used to produce the Energy Information Administration's Annual Energy Outlook, which projects the U.S. energy system through 2030 and is used as a benchmark against which other energy models are assessed. <http://www.eia.doe.gov/oiaf/aeo/overview/>
- *MARKet ALlocation (MARKAL) Model* was created by the DOE Brookhaven National Laboratory in the late 1970s, and is now supported by a large international users group. MARKAL quantifies the system-wide effects of changes in resource supply and use, technology availability, and environmental policy. The MARKAL model determines the least-cost pattern of technology investment and utilization required to meet specified demands and constraints, and tracks the resulting changes in criteria pollutant and CO₂ emissions. This model is a generic framework that is tailored to a particular application through the development of energy system-specific data. MARKAL databases have been developed by various groups for national, regional, and even metropolitan-scale applications. For example, EPA has developed national and Census-division level databases (<http://www.epa.gov/appcdwww/apb/globalchange/markal.htm>).

⁹ For more information about using capacity expansion models to estimate air and GHG emissions from clean energy initiatives, please see Section 4.2.2, Step 2: Quantify Air and GHG Emission Reductions from Clean Energy Measures.

MARKAL requires seconds to an hour to run on a desktop computer, depending on the size of the database and the options selected. <http://www.etsap.org/markal/main.html>

- *Energy 2020* is a simulation model that includes all fuel, demand, and supply sectors and simulates energy consumers and suppliers. This model can be used to capture the economic, energy, and environmental impacts of national, regional or state policies. *Energy 2020* models the impacts of a clean energy measure on the entire energy system. User inputs include new technologies and economic activities such as tax breaks, rebates, and subsidies. *Energy 2020* uses emission rates for NO_x, CO₂, SO₂, and PM for nine plant types included in the model. It is available at the national, regional and state levels. <http://www.energy2020.com/>

Key Considerations

While capacity expansion or system planning modeling is generally seen as very credible in long-run contexts, it:

- is more resource-intensive than the estimation methods and
- often lacks transparency due to its complexity and proprietary nature.

It is important to carefully consider key assumptions, such as fuel price forecasts and retirements, and the ability to accurately model the complex factors affecting the system including environmental and other regulatory requirements (e.g., renewable portfolio standards).

These assumptions point to the need for model validation or calibration against actual data or another projection model.

Most of the models are supported by their developers or other consultants who have available data sets. Some studies calibrate against the NEMS-generated Annual Energy Outlook produced by DOE's Energy Information Administration.

3.2.1.c Avoided Transmission and Distribution Capacity Costs

Clean energy policies and programs—such as customer-sited renewables and clean DG, including CHP—that are sited on or near a constrained portion of the T&D system, can potentially:

- Avoid or delay costly T&D upgrades, construction, and associated O&M costs, including cost of capital, taxes and insurance; and
- Reduce the frequency of maintenance, because frequent peak loads at or near design capacity will reduce the life of some types of T&D equipment.

Deferral of T&D investments can have significant economic value. The value of the deferral is calculated by looking at the present value difference in costs between the transmission project as originally scheduled and the deferred project. Most often, the deferred project will have a slightly higher cost due to inflation and cost escalations (e.g., in raw materials), but can have a lower present value cost when the utility discount rate is considered (which affects the utility's cost of capital). The difference in these two factors determines the value of deferring the project.

The avoided costs of T&D capacity vary considerably across a state depending on geographic region and other factors. Figure 3.2.4, *California T&D Avoided Costs by Planning Area in 2003*, was developed for the California Public Utilities Commission in 2003. It illustrates how avoided costs of T&D capacity vary in California (in \$/kW-year) by planning area, utility, climate zone, and time of day. Using avoided cost estimates based on these differences, rather than on state-wide system averages, enables states to better target the design, funding, and marketing of their clean energy actions (E3 and RMI, 2004; Baskette et al., 2006).

The benefit of avoided T&D costs is often overlooked or addressed qualitatively in resource planning, because estimating the magnitude of these costs is typically more challenging than estimating the avoided costs of energy generation and plant capacity. For example, the avoided T&D investment costs resulting from a clean energy program are highly location-specific and depend on many factors, including the current system status, the program's geographical distribution, and trends in customer load growth and load patterns. It is also difficult to estimate the extent to which clean energy measures would avoid or delay expensive T&D upgrades, reduce maintenance, and/or postpone system-wide upgrades, due to the complexity of the system.

FIGURE 3.2.4 CALIFORNIA T&D AVOIDED COSTS BY PLANNING AREA IN 2003



Source: Baskette et al., 2006.

The most appropriate approach for estimating avoided T&D costs is the *system planning approach*.¹⁰ The system planning approach uses projections and thus can consider future developments, whether conducted via a modeling or non-modeling approach. Generally, it is difficult to be precise when calculating the avoided cost of T&D capacity because these costs are very site-specific and their quantification involves detailed engineering and load flow analyses.

The system planning approach uses projected costs and projected load growth for specific T&D projects based on the results from a system planning study—a rigorous engineering study of the electric system to identify site-specific system upgrade needs. Other data requirements include site-specific investment and load data. This approach assesses the difference between the present value

of the original T&D investment projects and the present value of deferred T&D projects.¹¹

Another factor affecting location-specific T&D project cost estimates is system congestion and reliability. During periods of high congestion, interconnected resources that can be dispatched at these specific times are credited at time-differentiated avoided costs. This approach is used by the California PUC to estimate long-term avoided costs to support analyses of the cost-effectiveness of energy efficiency measures. [See Section 3.5, *Case Studies* (E3 and RMI, 2004)]. Reliability considerations are reflected in avoided cost calculations through consideration of the Loss of Load Probability (LOLP), which is an indicator of the probability of failure to serve loads (NARUC, 1992).¹²

Tools

Specialized proprietary models of the T&D system's operation may be used to identify the location and timing of system stresses. Examples of such models include the following:

PowerWorld Corporation offers an interactive power systems simulation package designed to simulate high voltage power systems operation on a variable time frame. <http://www.powerworld.com/>

Siemens (PSS®E) offers probabilistic analyses and dynamics modeling capabilities for transmission planning and operations. https://www.energy.siemens.com/cms/00000031/en/ueberuns/organizati/services/siemenspti/softwareso/Pages/psse_1439533.aspx

3.2.1.d Avoided Energy Loss During Transmission & Distribution

In addition to avoiding electricity generation, power plant capacity additions, and T&D capacity additions, clean energy policies and programs can avoid energy losses during T&D when these resources are located near the electricity consumer. Avoided energy losses during T&D can be estimated by multiplying the estimated energy and capacity savings from clean energy

¹¹ The investment in nominal costs is based on revenue requirements that include cost of capital, insurance, taxes, depreciation, and O&M expenses associated with T&D investment. (Feinstein et al., 1997; Orans et al., 2001; Lovins et al., 2002)

¹² LOLP can be used to allocate the marginal capacity costs to time periods (NARUC, 1992, 118). A LOLP of 0.01 means there is a one percent probability that the utility might not be able to serve some or all of customer load. Because LOLP increases as customer usage increases, a LOLP-weighted marginal capacity cost will be high during high LOLP periods.

¹⁰ A projected embedded analysis approach based on historic data also exists, but is considered appropriate for cost allocation during ratemaking. For estimating avoided costs due to energy efficiency measures it is important to consider future capital investment plans, making the system planning approach preferable.

VERMONT USES SYSTEM PLANNING APPROACH TO ESTIMATE AVOIDED TRANSMISSION COSTS

The Vermont Electric Company (VELCO) owns and maintains the bulk transmission facilities in the state to serve all the electric distribution utilities. In 2003, VELCO undertook a study of alternatives to a proposed major upgrade in the northwest corner of Vermont. The transmission upgrade was reliability-driven and urgently needed, which resulted in a very high bar for alternatives. VELCO reached an agreement with the Vermont Department of Public Service to conduct a thorough study of distributed generation, energy efficiency, and new central generation as alternatives to the upgrade.

The study identified a range of central generation and distributed generation options and estimated their costs. In addition, a location-specific study of the available energy efficiency potential and the program costs for delivering that potential was prepared. Various combinations of energy efficiency and generation were assembled as alternatives to the proposed transmission project and compared based on total present value of cost of service. The study determined the cost of the transmission upgrade and the cost of a smaller upgrade so that the difference in those two costs could be used to assess the cost-effectiveness of the alternative resource package. While the alternatives were not adopted, due in part to the fact that only the transmission option's costs could be spread across the whole ISO region, this study demonstrates one way to use the system planning approach to estimate avoided transmission costs.

Source: LaCapra Associates, 2003; Orans, 1989; Orans, 1992.

policies and programs located near or at a customer site by the T&D energy loss percentage. An approach for determining the energy loss is described below.

The energy loss factor is the percent difference between the total energy supplied to the T&D system and the total energy taken off the system for delivery to end-use customers during a specified time period, calculated as 1 minus (delivered electricity/supplied electricity). T&D losses in the range of 6 percent to 10 percent are typical, which means that for every 1 kWh saved at the customer's meter, 1.06–1.10 kWh is avoided at the generator.

Line loss is typically higher when load is higher, especially at peak times when it can be as great as twice the average value. The line loss reductions from energy efficiency, load control, and DG are thus significantly higher when the benefits are delivered on peak than when they occur at average load levels, which greatly enhances the reliability benefits. A clean energy measure that saves 1.0 kWh of power at the customer's meter may save, for example, 1.2 kWh from the generator

during peak hours simply because line losses are higher at peak times.

The significance of losses in high load periods is further increased by the high marginal energy costs and energy prices experienced at those times. Due to the variation in loads over the course of the year, T&D loss estimates are more precise when developed for short time periods (e.g., less than one year).

Utilities routinely collect average annual energy loss data by voltage level (as a percentage of total sales at that level). RTOs and ISOs also provide loss data. Note that transmission loss, which is smaller than distribution loss, may be included in wholesale energy prices in restructured markets.

Estimates of line loss can be applied to the energy impacts estimated as described in Chapter 2. If load profile information is available, then estimates can reflect the higher on-peak loss rate.

3.2.2 HOW TO ESTIMATE THE SECONDARY ELECTRIC SYSTEM BENEFITS OF CLEAN ENERGY RESOURCES

Clean energy policies and programs result in many additional electric system benefits that affect the efficiency of electric systems and energy markets. These *secondary* benefits have associated cost reductions, but the methodologies for assessing them are sometimes diverse, qualitative, and subject to rigorous debate. As described in Section 3.1, some of the key secondary benefits of clean energy to electric systems and markets include:

- Avoided ancillary service costs;
- Reductions in wholesale market prices;
- Increased reliability and improved power quality;
- Avoided risks associated with long lead-time investments, such as the risk of overbuilding the electric system;
- Reduced risks from deferring investments in traditional centralized resources until environmental and climate change policies take shape; and
- Improved fuel diversity and energy security.

The ability to estimate the secondary benefits of clean energy policies and programs and the availability of methods vary depending on the benefit. These

ANCILLARY SERVICES THAT CLEAN ENERGY RESOURCES CAN PROVIDE TO THE SYSTEM

Operating reserve – Spinning: Generation synchronized to the grid (i.e., “spinning”) and usually available within 10 minutes to respond to a contingency event. For example, 50 MW of spinning operating reserve means that a generation unit can increase its output by 50 MW within 10 minutes.

Operating reserve – Supplemental: Generation that is available within 30 minutes but is not necessarily synchronized to the grid.

Reactive Power/Voltage Support: The ability of a generator to “absorb” or “generate” reactive power to meet voltage standards on the grid.

methods are less mature than those for primary benefits, and as such tend to rely more upon non-modeling estimation approaches than more sophisticated simulation modeling ones. Secondary electric system benefits, and methods for estimating them, are described below.

3.2.2.a Avoided Ancillary Services Costs

“Ancillary services” is a catch-all term for electric generator functions needed to ensure reliability, as opposed to providing power, and include services such as operating reserves and voltage support.

Operating Reserves

Energy efficiency programs avoid the need for corresponding operating reserves (those generation resources available to meet loads quickly in the event a generator goes down or some other supply disruption occurs) and thus avoid the respective costs.

RTOs routinely report market prices for ancillary services. In those regions with ancillary service markets, such as PJM, NYISO, ISO-NE, ERCOT and the California RTO, services are provided at rates determined by the markets and thus are easily valued.¹³ The market value of a given MW of clean energy short-term reserve is equal to the operating reserve price, as posted by the RTO or ISO on its Web site.

Voltage Support

Voltage support is important to ensure the reliable and safe operation of electricity-consuming equipment and the grid. There are few market metrics available

¹³ There can be opportunity costs associated with provision of operating reserve. Some regions allow demand response and other clean energy resources to bid directly into the energy market.

DEMAND RESPONSE COULD IMPROVE PLANT UTILIZATION AND REDUCE EMISSIONS IN NEW ENGLAND

Compared with other regional control areas, New England has a small amount of quick-start capacity relative to the regional peak load. As such, a number of large oil- and gas-fired steam units that do not have the ability to start quickly must run constantly to provide reserve capacity. A study conducted for the New England Demand Response Initiative (NEDRI) used a production costing model (PROSYM/MULTISYM) to evaluate how hypothetical aggressive demand response programs implemented during the summer of 2006 would affect power plant utilization and net emissions when such programs are used for reserve capacity. The study found that the demand response programs could result in more efficient plant utilization, reducing operation of the steam units, and increasing operation of efficient combined-cycle units in the region. If no diesel generators participate in the demand response programs, the study identified the additional potential for reductions in NO_x, SO₂, and CO₂ emissions during the summer.

Source: Synapse Energy Economics, 2003.

to estimate the price of voltage support benefits. The reactive power provisions in Schedule 2 of the FERC pro forma open access transmission tariff, or an RTO’s equivalent schedule for reactive support, can be used as a proxy for the avoided cost of voltage support. However, the Schedule 2 payments are often uniform across a large region. As a result, they may not capture differences in the value of these services in load pockets. Alternately, the difference in reliability with and without the clean energy resource can also give some indication of voltage support benefits. (See the reliability metrics discussion in Section 3.2.2.c *Increased Reliability and Power Quality*.)

Some clean energy measures can have direct beneficial effects on avoiding certain voltage support or reactive power requirements. Reactive power ancillary services are local in nature, and clean energy policies and programs that reduce load in a load pocket area can minimize the need for local reactive power requirements. On the other hand, solar and wind resources may require backup voltage support due to their intermittent nature.

It is important to note that the avoided costs of reactive power and other ancillary services are typically smaller than other costs, such as avoided energy, capacity, and T&D investment. For example, 2003 reactive power payments were only 0.52 percent of the total costs of serving load in PJM (Burkhart, 2005).

3.2.2.b Reduction in Wholesale Market Clearing Prices

In addition to the benefits of reduced wholesale electricity costs (i.e., avoided energy and capacity costs described in Section 3.3), clean energy resources can reduce the wholesale market clearing price for electricity as a result of decreased demand for electricity, gas, or both. This can directly benefit both utilities and consumers.

The methods for estimating short-run wholesale market price effects involve relatively well-understood data and are reasonably straightforward to apply. In contrast, wholesale market price effects over the long term involve relatively poorly understood relationships, and estimating these price effects can become quite complex. For this reason, this section presents the steps involved in estimating the magnitude of the price effects of resource additions in the near term using a basic approach. For longer-term forecasts, a more sophisticated approach such as a dispatch model may be preferred.

The potential market price decrease attributable to a particular clean energy resource can be estimated based on a load curve analysis as follows.

Step 1. Determine the time period for which the calculation is to be made.

Step 2. Determine the size of the clean energy resource (and the hourly shape if relevant), typically in MW. (For more information, see Step 1: Estimate Clean Energy Operating Characteristics in Section 3.2.1.a)

Step 3. Develop a dispatch curve that can be based upon either generating unit data (i.e., capacity ratings and operating costs) or market clearing price data (typically available from the ISO or control area operator). (For more information, see Step 2: Identify the Marginal Units to be Displaced in Section 3.2.1.a)

Step 4. Calibrate or validate the calculation for the case without the clean energy resource.

Step 5. Analyze a case with the clean energy resource by reducing demand or adding supply to represent the clean energy resource.

Step 6. Compare the wholesale market price results for the two cases. The difference is the wholesale market

PRICE EFFECTS OF DEMAND RESPONSE IN THE NORTHEAST IN JULY AND AUGUST, 2006

In all four of the structured, RTO-run eastern spot electricity markets, historically high peak load values occurred during a week-long heat wave in August 2006. Market coordinators from New York (over 1,000 MW of load reduction), PJM (520 MW of peak reduction) and New England (625 MW of peak reduction) all acknowledged the role that demand response played in keeping peak load lower than what otherwise would have occurred.

For example, PJM estimated that wholesale prices would have been \$300/MWh higher without demand response during the highest demand hours of the heat wave, corresponding to a reported savings of about \$650 million for energy purchasers. Payments to all demand response providers totaled only \$5 million; even considering the potential costs of demand response programs, such as program administration costs, the benefit-cost ratio is favorable.

Source: PJM, 2006a, PJM, 2006b.

PRICE EFFECTS DUE TO THE NEW YORK ENERGY \$SMART PROGRAM

An evaluation of the cost-effectiveness of a portfolio of programs under NYSERDA's New York Energy \$mart public benefits program estimated the reduction in average wholesale electricity prices over the period 2006 (full implementation of program) to 2008 (the year after which no currently known planned new capacity is assumed to come online). The analysis used a production cost model, Multi Area Production Simulation Software (MAPS), to compare the average annual wholesale electricity commodity prices in two cases: one with the New York Energy \$martSM Program (the base case), and a one without the program benefits (the sensitivity case). The study estimated electricity market price reductions of about \$11.7 million in 2003 to \$39.1 million (in 2004 dollars) in 2023 as a result of the program.

Source: Heschong Mahone Group, 2005.

price reduction benefit (expressed in \$/MWh or total dollars for the time period).

This approach for calculating the market price change can be applied to the electric *energy* market and *capacity* market, if one exists in the region. This benefit can be calculated using spreadsheets, an electric system dispatch model (e.g., MAPS, ProSym), or an energy system model for a more aggregated estimate. Another approach, used by the CPUC in California's avoided cost proceeding, is to use historical loads and prices (CPUC, 2006).

RELIABILITY CONCEPTS

Reliability refers to the electric system's availability to consistently serve the demanded load.

Power Quality refers to the consistency of voltage of electricity supplied to electrical equipment (usually meaning the voltage stays within plus or minus 5 percent).

RELIABILITY INDICES

SAIFI (system average interruption frequency index): the average frequency of sustained interruptions per customer over a predefined area. It is calculated as the total number of customer interruptions divided by the total number of customers served.

SAIDI (system average interruption duration index): commonly referred to as customer minutes of interruption or customer hours, it provides information on the average time customers are interrupted. It is calculated as the sum of the restoration time for each interruption event times the number of interrupted customers for each interruption event divided by the total number of customers.

CAIDI (customer average interruption duration index): the average time needed to restore service to the average customer per sustained interruption. It is calculated as the sum of customer interruption durations divided by the total number of customer interruptions.

MAIFI (momentary average interruption frequency index): considers momentary interruptions resulting from each single operation of an interrupting device, such as a recloser. It is calculated as the total number of customer momentary interruptions divided by the total number of customers served.

RELIABILITY BENEFITS OF CLEAN ENERGY

Clean energy provides reliability benefits because when a small clean energy unit fails, the result is less catastrophic than when one large, traditional generating unit fails. For example, suppose a utility has the choice of installing one hundred kilowatts of clean DG around its system or installing a single 10 megawatt generator (100 units times 100 kW). In this situation, there would likely be a greater probability of the 10 MW generator being out of service than of finding all 100 of the smaller units out of service. Such an effect can either reduce the reserve margin required (which benefits both the utility and consumers) or, if the reserve margin is fixed, reduce the price of reserve capacity (Lovins et al., 2002).

THE IMPORTANCE OF POWER QUALITY

It is important to maintain consistent power quality; otherwise, electrical equipment can be damaged. For example, consumer and commercial electrical and electronic equipment is usually designed to tolerate extended operation at any line voltage within 5 percent nominal, but extended operation at voltages far outside that band can damage equipment or cause it to operate less efficiently.

3.2.2.c Increased Reliability and Power Quality

An expansion in the use of clean energy resources can improve both the reliability of the electricity system and power quality. For example, California's investments in energy efficiency, conservation, and demand response played a role in averting rolling blackouts in the summer of 2001. Power quality problems occur when there are deviations in voltage level supplied to electrical equipment. Some forms of clean energy resources, such as fuel cells, can provide near perfect power quality to their hosts.

Reliability Metrics

Although clean energy resources can improve system reliability, measuring these benefits can be difficult. The most common reliability metrics are indices, which are relatively well-established and straightforward to calculate (see text box, *Reliability Indices*). Historical reliability data are often available.

Converting reliability benefits into dollar values is complex, however, and the results of studies that have attempted to do so are controversial. For this reason, their use in support of resource decisions is less common than for other, well-established benefits, such as the avoided costs of generation, capacity, and T&D.

Power Quality Metrics

The data needed to assess power quality benefits are neither consistently measured nor comprehensively collected and reported. Specialized monitoring equipment is typically necessary to measure power defects, and acceptable standards for power quality have been changing rapidly.

Power quality improvements produce real economic benefits for electricity consumers by avoiding damage to equipment and associated loss of business income and product, and, in some cases, the need for redundant power supply. At the extreme, some commercial and industrial processes, such as silicon chip fabrication and online credit card processing, are so sensitive to outages or power quality deviations that customers take proactive steps to avoid these concerns, including construction of redundant transmission lines or installing diesel or battery backup power. The costs of such equipment could also be used to estimate the value of increased reliability and power quality.

3.2.2.d Avoided Risks Associated with Long Lead-time Investments Such as the Risk of Overbuilding the Electric System

Clean energy options provide increased flexibility to deal with uncertainty and risk related to large, traditional fossil fuel resources, including:

- Clean energy resources, such as wind and photovoltaics, reduce the impact on electric system costs from fuel price uncertainty relative to traditional resources, and lower the financial risks and costs associated with generation.
- In terms of resource planning, clean energy options offer great flexibility. If one is unsure that long-term forecasts for load growth are 100 percent accurate, then clean energy resources offer greater flexibility due to their modular nature and relatively quick installation times relative to traditional resources.¹⁴
- Clean energy resource options provide more time to develop technologically advanced, less polluting, more efficient, large-scale technologies.

All other things being equal, a resource or resource plan that offers more flexibility to respond to changing future conditions is more valuable than a less flexible resource or plan. Techniques such as decision tree analysis or real option analysis provide a framework for assessing this flexibility. These approaches involve distinguishing between events within one's control (i.e., decision nodes) and those outside of one's control (i.e., exogenous events) and developing a conceptual model for these events as they would occur over time. Specific probabilities are generally assigned to the exogenous events. The results of this type of analysis can include the identification of the best plan on an expected value basis (i.e., incorporating the uncertainties and risks) or the identification of lower risk plans.

Above and beyond the expected value of the plan, certain resources may have some "option value" if they allow (or don't foreclose) other resource options in the future. For example, a plan that involves implementing some DSM in the near term can have value above its simple short-run avoided cost, in that it develops the capability for expanded DSM deployment in the future if conditions call for it.

¹⁴ Of course, clean energy resources carry their own risk of non-performance.

THE IMPORTANCE OF LOW PERFORMANCE CORRELATIONS

Similar resources (e.g., fossil fuels such as coal and oil) tend to face similar specific risks, and as a result their performances tend to be correlated. For example, coal and oil both emit CO₂ when burned and thus could be associated with future climate change regulatory risk, which in turn would likely increase costs and affect the performance of oil- or coal-fired generation. On the other hand, disparate resources (e.g., coal and wind) have lower performance correlations—and hence more value for offsetting resource-specific risks within the portfolio—than resources that have little disparity.

3.2.2.e Reduced Risks from Deferring Investment in Traditional, Centralized Resources Pending Uncertainty in Future Environmental Regulations

Clean energy resources offer planners options for mitigating current and future environmental regulation risks. Clean energy can reduce the cost of compliance with air pollution control requirements. Utilities and states also see clean energy as a way to reduce their financial risk from future carbon regulations.

For example, a 2008 study looked at 10 utilities in the western U.S. and examined how their respective resource plans accounted for future carbon regulations. The study found that the majority of the 10 utilities included aggressive levels of energy efficiency and renewable energy to reduce carbon emissions. The study also found that in making these decisions the utilities did not consider the indirect impacts of future carbon regulations, such as increased wholesale electric market price, retirements of conventional generation plants, and the impact on transmission and distribution expansion (Barbose et al., 2008).

When comparing new generation options in the face of potential environmental regulations, some states and utilities are reducing financial risk by placing a higher cost premium on traditional resources relative to clean energy. For example, California has adopted an \$8/ton carbon dioxide greenhouse gas adder to be used in comparing resources (Johnston et al., 2005; CA PUC, 2004).

3.2.2.f Improved Fuel Diversity and Energy Security

Portfolios that rely heavily on a few energy resources are highly affected by the unique risks associated with any single fuel source. In contrast, the costs of clean

FIGURE 3.2.5. NATURAL GAS AND ELECTRICITY PRICES IN NEW ENGLAND

A large portion of New England's electricity is generated from natural gas. Due to this high dependence on one fuel source, and because fuel represents a large portion of the cost to produce electricity, natural gas and electricity prices are highly correlated.

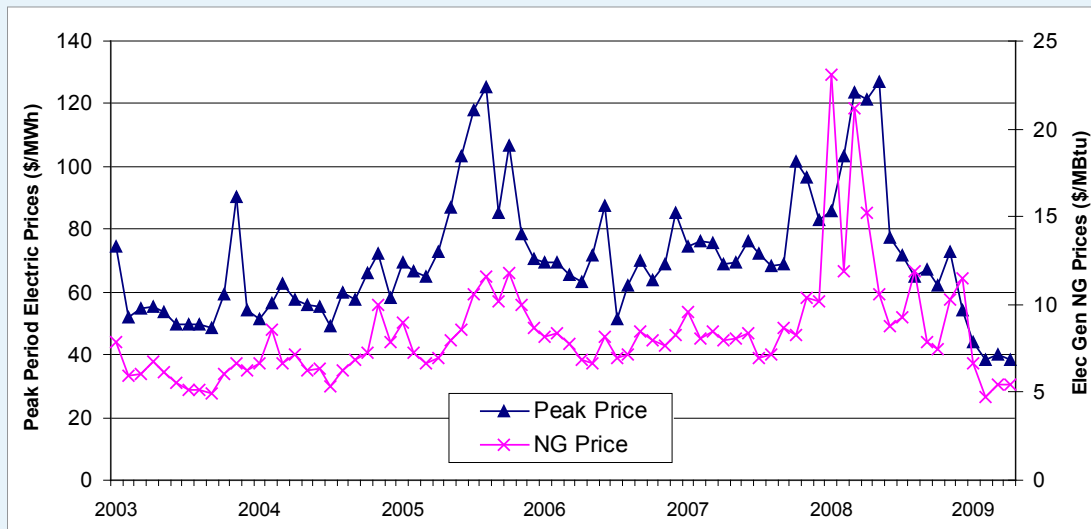

Sources: EIA; ISO NE, summary of monthly data, 2006.

energy resources are not affected by fossil fuel prices and thus can hedge against fossil-fuel price spikes by reducing exposure to this volatility.

Diversity in technology can also reduce the likelihood of supply interruptions and reliability problems. For example, while geothermal plants can be expensive to construct, they offer an almost constant supply of energy and are best suited for baseload generation. Gas turbines, on the other hand, are relatively inexpensive to construct and can start quickly, but have a high operating cost and so are best suited for peaking generation. Figure 3.2.5 illustrates the relationship between electricity and natural gas prices in New England.

Two approaches for estimating the benefits of fuel and technology diversification include market share indices and portfolio variance.

- *Market share indices.* Market share indices, such as the Herfindahl-Hirschmann Index and Shannon-Weiner index, identify the level of diversity as a function of the market share of each resource.¹⁵ These indices are computationally simple and the

¹⁵ For more information about these indices, see U.S. Department of Justice and the Federal Trade Commission, Issued April 1992; Shannon, C.E. "A mathematical theory of communication." *Bell System Technical Journal* 27: 379–423 and 623–656, July and October 1948.

data required for the indices (annual state electricity generation by fuel type and producer type) are readily available from the EIA Form 906 database.¹⁶ Use of these indices is appropriate for preliminary resource diversity assessment and as a state or regional benchmark. Annual state electricity generation data by producer type and fuel type are available.

A limitation of these indices is that decisions on how to classify resources (e.g., calculating the share of all coal rather than bituminous and subbituminous coals separately) can have a large effect on the results. Another shortcoming is that the indices do not differentiate between resources that are correlated with each other (e.g., coal and natural gas) and thus can underestimate the portfolio risk when correlated resources are included.

- *Portfolio Variance.* The concept of portfolio theory suggests that portfolios should be assembled and evaluated based on the characteristics of the portfolio, rather than on a collection of individually assessed resources. Portfolio theory and portfolio variance measures account for risk and uncertainty by incorporating correlations between resources

¹⁶ EIA Form 906 has been superseded by EIA Form 923. Both data sets are available at http://www.eia.doe.gov/cneaf/electricity/page/eia906_920.html

when projecting overall portfolio performance, as measured by the standard deviation of cost or some other measure of performance. The standard deviation can be calculated for a number of portfolios, each with a variety of different resources, to find portfolios that simultaneously minimize cost and risk. It is important to acknowledge this inherent trade-off between cost and risk; there is not a single portfolio that lowers both.

Like market share metrics, portfolio analysis does not readily incorporate the non-price and qualitative benefits of fuel diversity, such as energy independence, which can be a benefit of clean energy. It is safer to have many smaller, generating resource units that are located in a variety of locations and do not require fuel stored on-site than to have one easily targeted large unit. Also, using domestic clean energy resources to reduce dependence on foreign fuel sources, such as imported petroleum, may yield political and economic benefits by protecting consumers from supply shortages and price shocks. Care should be taken to consider price as well as factors that are not easily quantified when choosing among portfolios with different cost-risk profiles.

3.3 CASE STUDIES

The following two case studies illustrate how assessing the electric system benefits associated with clean energy can be used in the state energy planning and policy decision-making process.

3.3.1 CALIFORNIA UTILITIES' ENERGY EFFICIENCY PROGRAMS

Benefits Assessed

- Avoided electricity generation costs
- Avoided T&D costs
- Avoided environmental externality costs
- Avoided ancillary services costs
- Reduced wholesale market clearing prices

Clean Energy Program Description

In 2005, the California Public Utilities Commission (CPUC) approved a new method for calculating avoided costs for use in evaluating 2006–2008 utility energy efficiency programs in California.

TABLE 3.3.1 COMPARISON OF OLD AND NEW AVOIDED COST METHODOLOGIES

Avoided Cost	New Methodology		Old Methodology	
	Time	Area	Time	Area
Avoided electricity generation costs	Hourly	Utility-specific	Annual Average Values	Statewide
Avoided Electric Transmission & Distribution Costs	Hourly	Utility, planning area and climate zone specific		
Avoided Natural Gas Procurement	Monthly	Utility-specific		
Avoided Natural Gas Transportation & Delivery	Monthly	Utility-specific		
Environmental externality Adders for Electric and Gas	Annual value, applied by hour per implied heat rate	System-wide (uniform across state)		
Reliability adder (Avoided ancillary services costs)	Annual value	System-wide (uniform across state)	None	None
Price elasticity of demand adder (Reduced wholesale market clearing prices)	Time of use period (on- vs. off-peak) by month	System-wide (uniform across state)	None	None

Source: E3 and RMI, 2004

FIGURE 3.3.1 COMPARISON OF AVOIDED COSTS FOR THREE EXAMPLE MEASURES

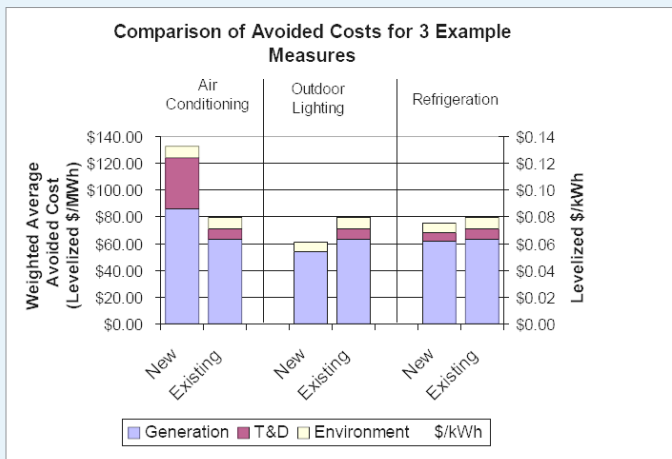

Source: E3 and RMI, 2004.

Method(s) Used

The methodology is described in a detailed report issued in October 2004, *Methodology and Forecast of Long Term Avoided Costs for the Evaluation of California Energy Efficiency Programs* (E3 and RMI, 2004). The new methodology includes five major categories of costs that are avoided when demand is reduced through installation of energy efficiency resources. It produces time- and location-specific cost estimates, whereas the previous avoided cost methodology relied more upon average statewide values. Table 3.3.1 summarizes the differences between the old and new methodologies. The key findings of this study were based on the avoided costs derived from the new methodology and an avoided costs spreadsheet model that allows ongoing updates to account for changes in variables such as fuel prices.

Results

These results demonstrated the value of estimating avoided costs using time- and location-specific data by highlighting the importance of reducing demand during peak hours. It found that avoided costs (especially T&D avoided costs) were particularly high during peak hours and the peak summer season.

Figure 3.3.1 shows the results of avoided cost calculations for three different efficiency resources—air conditioning, outdoor lighting, and refrigeration programs—using both the new and existing methodologies. The largest difference in avoided costs between the new and the old methods occurred in the air conditioning program (\$133/MWh with the new method compared with \$80/MWh with the old method), illustrating the higher value placed on peak hour reductions. Outdoor lighting and refrigeration measures had lower avoided cost values when estimated with the new method than with the old method, because these appliances are used off-peak or throughout the day—many hours of which have very small avoided costs. Outdoor lighting appliances had the lowest values because they are used off-peak, when there are no avoided values for T&D. Since the initial avoided cost values were adopted, the CPUC adopted correction factors for residential and commercial air conditioning measures to better account for their previously undervalued peak load reduction contribution.¹⁷ (CPUC, 2006)

As shown in Table 3.3.2, when applying this new methodology, California’s energy efficiency programs are estimated to have a total program lifetime benefit of

¹⁷ Hourly avoided costs are averaged over the time-of-use periods for measures whose hourly load data are not available. Because this method did not use a load-weighted average, the measures that make a significant contribution to peak load reduction such as air conditioning were undervalued. To address this problem, the CPUC adopted correction factors for air conditioning measures to increase the averaged avoided cost values.

TABLE 3.3.2 ESTIMATED COST EFFECTIVENESS TEST RESULTS FOR THE CALIFORNIA INVESTOR OWNED UTILITIES’ 2006–2008 EFFICIENCY PROGRAMS

Costs & Benefits	SDG&E	SoCalGas	SCE	PG&E	Total
Total costs to billpayers (TRC)	\$299,443,761	\$225,381,390	\$857,516,394	\$1,341,473,455	\$2,723,814,999
Total savings to billpayers (TRC)	\$579,619,963	\$318,003,849	\$2,367,984,783	\$2,153,115,608	\$5,418,724,203
Net Benefits to billpayers	\$280,176,202	\$96,622,459	\$1,510,468,390	\$811,642,153	\$2,694,909,204

Source: CPUC, 2005

\$5.4 billion, twice as large as the cost of the programs¹⁸ (CPUC, 2005).

For More Information

- *Energy Efficiency Portfolio Plans and Program Funding Levels for 2006-2008 - Phase 1 Issues*. California Public Utilities Commission. Interim Opinion. September 22, 2005. http://www.cpuc.ca.gov/PUBLISHED/FINAL_DECISION/49859.htm

3.3.2 ENERGY EFFICIENCY AND DISTRIBUTED GENERATION IN MASSACHUSETTS

Benefit(s) Assessed

- Reduction in wholesale market clearing prices
- Avoided greenhouse gas (CO₂) emissions

Clean Energy Program Description

This study explores the potential price and emissions benefits of different options to increase distributed generation and energy efficiency in Massachusetts. The options include the addition of the following new demand resources over the baseline scenario through 2020:

- photovoltaics (PV),
- energy efficiency (EE),
- combined heat and power (CHP), and
- combined EE and CHP.

Method(s)

The analysis required the development of a reference case to determine what the wholesale electric prices and carbon dioxide emissions would be without the additional clean energy resources. It assumed no ratepayer-funded investments in demand side management (DSM) programs beginning in 2007 and so it assumed energy savings achieved through the end of 2006 remain constant in the future. The reference case also assumed no new policies to encourage distributed generation.

¹⁸ As a result of the energy efficiency programs, California's investor-owned utilities project savings of about 7,370 GWh of electricity, 1,500 MW of peak demand, and 122,000 megatherms of natural gas from 2006 to 2008. Relative to a base case without the programs, the utilities expect to reduce carbon dioxide emissions by about 6,600,000 tons — the equivalent of the emissions of about 1.2 million cars over the same period.

FIGURE 3.3.2 REDUCTION IN AVERAGE ANNUAL WHOLESALE ELECTRIC ENERGY PRICE FOR MASSACHUSETTS PURCHASES IN 2020 UNDER PV, EE, AND CHP+EE CASES

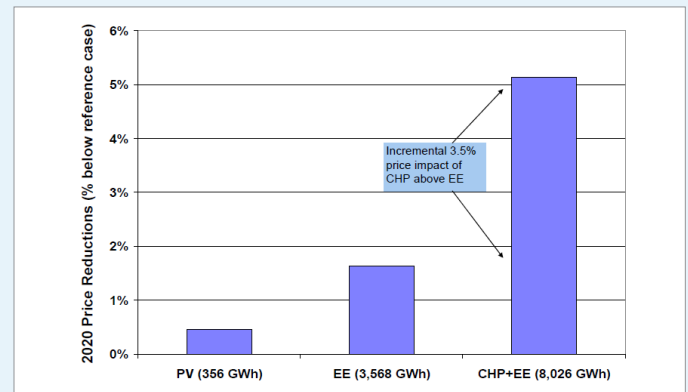

Source: *Impacts of Distributed Generation on Wholesale Electric Prices and Air Emissions in Massachusetts*, Synapse Energy Economics, March 31, 2008.

FIGURE 3.3.3 REDUCTIONS IN REGIONAL CO2 EMISSIONS IN 2020 UNDER PV, EE, AND CHP+EE CASES RELATIVE TO REFERENCE CASE MASSACHUSETTS CO2 EMISSIONS

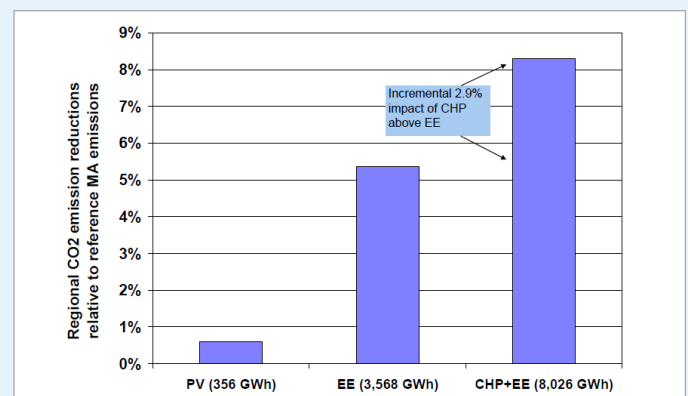

Source: *Impacts of Distributed Generation on Wholesale Electric Prices and Air Emissions in Massachusetts*, Synapse Energy Economics, March 31, 2008.

The analysis used the PROSYM simulation model to determine the potential price and emissions impacts of the scenarios. The model was used to simulate the average hourly wholesale market clearing prices and the regional greenhouse gas emissions (apportioned to Massachusetts based on GWh load) in 2020 under a reference case and each of the following four scenarios:

- 250 MW of incremental PV;
- Investment in EE sufficient enough to reduce annual growth of Massachusetts' energy consumption to 0.6 percent;
- 750 MW of incremental DG from CHP; and
- A combined CHP and EE case.

The scenarios are compared against the reference case to determine the impacts.

Results

The study projected that the combined effect of the PV, EE, and CHP would be to virtually eliminate load growth in Massachusetts.

In terms of impact on wholesale market prices:

- the 250MW of PV is expected to displace 356 GW of purchases from the wholesale market and reduce wholesale market prices by \$.033/MWh or 0.4 percent,
- EE is expected to reduce prices by 1.6 percent, and
- the combined EE and CHP scenario would produce a 5.1 percent reduction in prices.

These market price changes will affect the wholesale energy costs paid by Massachusetts customers. Even though it is expected to achieve the lowest reduction in market clearing prices, PV is expected to achieve the largest wholesale market cost savings to Massachusetts consumers: \$65 for every MWh generated by PV. EE is estimated to reduce costs by \$24 for every MWh saved. The study estimates a savings of \$35 per MWh of CHP generation. The values are different due to the different load shape profiles for each resource and the timing (and costs) for when each is likely to be used.

For greenhouse gas emissions, each of the alternative scenarios would achieve reductions of CO₂ emissions relative to the reference case. The combined EE and CHP scenario is likely to produce the greatest impact, with a reduction of 2.4 million short tons CO₂ /year in 2020. The majority of these reductions come from EE.

For More Information

- *Impacts of Distributed Generation on Wholesale Electric Prices and Air Emissions in Massachusetts*, Synapse Energy Economics, March 31, 2008. <http://www.masstech.org/dg/2008-03-Synapse-DG-Impacts-on-NE.pdf>

Information Resources

Resource	URL Address
Summary of Rigorous Modeling Tools	
EnerPrise Market Analytics (powered by PROSYM)	http://www1.ventyx.com/analytics/market-analytics.asp
Multi-Area Production Simulation (MAPS)	http://www.gepower.com/prod_serv/products/utility_software/en/ge_maps/index.htm
Plexos for Power Systems	http://www.energyexemplar.com
PowerBase Suite (including Promod IV)	http://www1.ventyx.com/analytics/promod.asp
Capacity Expansion available from Ventyx	http://www1.ventyx.com/products-services.asp
PowerBase Suite (including Strategist)	http://www1.ventyx.com/products-services.asp
IPM available from ICF International	http://www.icfi.com/Markets/Energy/energy-modeling.asp#2
PROSYM	http://www1.ventyx.com/analytics/market-analytics.asp

Information Resources

Resource	URL Address
Primary Electric System Benefits	
Bureau of Economic Analysis	http://www.bea.gov
California Database for Energy Efficient Resources (DEER). California Energy Commission database.	http://www.energy.ca.gov/deer
California ISO	http://oasis.caiso.com/
California Public Utilities Commission (CPUC) 2006. Interim Opinion: 2006 Update of Avoided Costs and Related Issues Pertaining to Energy Efficiency Resources. Decision 06-06-063 June 29, 2006	http://www.cpuc.ca.gov/PUBLISHED/COMMENT_DECISION/56572.htm#P86_2251
E3 and RMI, Methodology and Forecast of Long Term Avoided Costs for the Evaluation of California Energy Efficiency Programs, October 26, 2004	http://www.ethree.com/CPUC/E3_Avoided_Costs_Final.pdf
EIA Annual Energy Outlook	http://www.eia.doe.gov/oiaf/aeo/index.html
EIA Form EIA-860 (Annual generator data)	http://www.eia.doe.gov/cneaf/electricity/page/eia860.html
EIA Form EIA-861	http://www.eia.doe.gov/cneaf/electricity/page/eia861.html
EIA Form EIA-906 and 920 (power plant database) - now EIA-923	http://www.eia.doe.gov/cneaf/electricity/page/eia906_920.html
FERC Form 1	http://www.ferc.gov/docs-filing/eforms/form-1/viewer-instruct.asp
FERC Form 714 (control area info)	http://www.ferc.gov/docs-filing/eforms/form-714/overview.asp
FERC Form 423 (cost and quality of fuels)	http://www.eia.doe.gov/cneaf/electricity/page/eia423.html
Handy–Whitman 2006. Handy-Whitman Index of Public Utility Construction Costs, a plant cost index that has been published semi-annually since the 1920s, is published by Whitman, Requardt & Associates, LLP.	http://www.business-magazines.com/prd135331.php?siteid = global_BMS_product
Independent System Operators/ Regional Transmission Organizations	
ISO New England	http://www.iso-ne.com/
Keith, G., B. Biewald and D. White 2004. Evaluating Simplified Methods of Estimating Displaced Emissions in Electric Power Systems: What Works and What Doesn't.	http://www.synapse-energy.com/Downloads/SynapseReport.2004-11.CEC-.Evaluating-Simplified-Methods-of-Estimating-Displaced-Emissions.04-62.pdf
Midwest ISO	http://www.midwestiso.org/home
NYISO	http://www.nyiso.com/public/index.jsp
NYMEX	http://www.nymex.com/index.aspx
Platt's MegaWatt Daily publishes forward electricity market prices through this paid subscription newsletter.	http://www1.platts.com/Electric%20Power/Newsletters%20&%20Reports/Megawatt%20Daily/

Information Resources

Resource	URL Address
PJM	http://www.pjm.com/index.jsp
Portfolio Management: Tools and Practices for Regulators, prepared for the national Association of Regulatory Utility Commissioners (NARUC), July 17, 2006.	http://www.synapse-energy.com/Downloads/SynapseReport.2006-07.NARUC.Portfolio-Management-Tools-and-Practices-for-Regulators.05-042.pdf
SEC 10K filings.	http://www.sec.gov/edgar/searchedgar/companysearch.html
State regulatory commission rate base and fuel clause adjustment filings	http://www.naruc.org/
The Massachusetts DG Collaborative Benefits and Costs of Distributed Generation website compiles a comprehensive list of studies regarding costs and benefits of distributed generation and distribution planning including the analysis conducted by the Massachusetts DG Collaborative and Navigant Consulting Inc.	http://www.masstech.org/dg/Benefits.htm
This Excel lookup table contains distribution system deferral values for each of the utilities included in the Distribution System Cost Methodologies paper by Shirley W. (2001) for the Regulatory Policy Project's Distributed Resource Policy Series.	http://www.raponline.org/Pubs/DRSeries/CostTabl.zip
Reduction in Wholesale Market Clearing Prices	
E3 and RMI, Methodology and Forecast of Long Term Avoided Costs for the Evaluation of California Energy Efficiency Programs, October 26, 2004	http://www.ethree.com/CPUC/E3_Avoided_Costs_Final.pdf
Hadley, S.W., et al. 2003. Quantitative Assessment of Distributed Energy Resource Benefits. (page 8-19)	http://www.ornl.gov/~webworks/cppr/y2001/rpt/116227.pdf
Heschong Mahone Group, Inc., Ridge & Associates, Energy and Environmental Economics, Inc. 2005. New York Energy Smart Program Cost-Effectiveness Assessment June 2005. Prepared for: The New York State Energy Research and Development Authority (NYSERDA). (page 23 and 39)	http://www.nyserda.org/Energy_Information/ContractorReports/Cost-Effectiveness_Report_June05.pdf
Synapse Energy Economics. 2006. Portfolio Management: Tools and Practices for Regulators, prepared for the national Association of Regulatory Utility Commissioners (NARUC), July 17, 2006.	http://www.synapse-energy.com/Downloads/SynapseReport.2006-07.NARUC.Portfolio-Management-Tools-and-Practices-for-Regulators.05-042.pdf
Increased Reliability and Power Quality	
GE Corporate Research and Development. 2003. DG Power Quality, Protection, and Reliability Case Studies Report. Prepared for NREL. August 2003	http://www.localpower.org/documents/reporto_nre_powerquality.pdf
IEEE Std. 1366-1998: Trial Use Guide for Electric Power Distribution Reliability Indices. Organization: IEEE	http://standards.ieee.org/reading/ieee/std_public/description/td/1366-1998_desc.html
New Power Technologies presented a methodology to evaluate the impacts of distributed energy resources on the grid operation in its 2005 paper "Optimal Portfolio Methodology for Assessing Distributed Energy Resources Benefits for the ENERGINET SM " prepared for California Energy Commission. April 2005.	http://www.energy.ca.gov/2005publications/CEC-500-2005-096/CEC-500-2005-096.PDF
ORNL TM-2004/91, Measurement Practices for Reliability and Power Quality: A Toolkit of Reliability Measurement Practices, John D. Kueck, Brendan J. Kirby, Philip N. Overholt, Lawrence C. Markel, June 2004.	http://www.ornl.gov/sci/btc/apps/Restructuring/ORNLTM200491FINAL.pdf
Avoided Risks	

Information Resources

Resource	URL Address
Biewald, Bruce, Tim Woolf, Amy Roschelle, and William Steinhurst 2003. <i>Portfolio Management: How to Procure Electricity Resources to Provide Reliable, Low-Cost, and Efficient Electricity Services to All Retail Customers</i> . Synapse Energy Economics. Prepared for the Regulatory Assistance Project and the Energy Foundation. October, 2003.	http://www.raponline.org/Pubs/PortfolioManagement/SynapsePMpaper.pdf
Brealey, Richard A., and Stewart C. Myers 2002. <i>Principles of Corporate Finance</i> , Irwin McGraw-Hill, New York.	N/A
Dixit, A.K. & R.S. Pindyck 1994. "Investment under Uncertainty." Princeton University Press, Princeton, N.J., 1994.	N/A
Lovins, A.B., E. K. Datta, T. Feiler, K. R. Rabago, J.N. Swisher, A. Lehmann, and K. Wicker 2002. <i>Small is Profitable: the Hidden Economic Benefits of Making Electrical Resources the Right Size</i> .	http://www.smallisprofitable.org/
New England Electric System 1993. NEESPLAN 4. Westborough, MA: New England Electric System, Nov. 1993. California ISO Midwest ISO	N/A
"The Professional Risk Managers' Guide to Energy & Environmental Markets," edited by Peter C. Fusaro, PRMIA, 2006.	N/A
Fuel and Technology Diversification	
EIA Form EIA-906 and 920 (power plant database) - now EIA-923	http://www.eia.doe.gov/cneaf/electricity/page/eia906_920.html
Grubb, M., Butler, L., and Twomey, P., 2005. Diversity and security in UK electricity generation: The influence of low-carbon objectives. <i>Energy Policy</i> , article in press.	http://dx.doi.org/10.1016/j.enpol.2005.09.004
Portfolio management tools, programs, and skill sets for utilities and utility commissions ("Portfolio Management: Tools and Practices for Regulators" Synapse, 2006)	http://www.synapse-energy.com/Downloads/SynapseReport.2006-07.NARUC.Portfolio-Management-Tools-and-Practices-for-Regulators.05-042.pdf

References	URL Address
AESC 2005. <i>Avoided-Energy-Supply-Component (AESC) Study Group. Avoided Energy Supply Costs in New England</i> . December 23 2005.	http://publicservice.vermont.gov/pub/aescstudy.html
Barbose, G., Ryan Wiser, Amil Phadke and Charles Goldman. "Reading the Tea Leaves: How Utilities in the West are managing Carbon Regulatory Risk in their Resource Plans." LBNL, March 2008.	http://eetd.lbl.gov/ea/emp/reports/lbnl-44e.pdf
Baskette, C., B. Horii, E. Kollman, S. Price. 2006. "Avoided Cost Estimation and Post-reform Funding Allocation for California's Energy Efficiency Programs." In <i>Energy</i> . Elsevier. Vol. 31, pp. 1084-1099.	N/A
Biewald, B. 2005. <i>Using Electric System Operating Margins and Build Margins in Quantification of Carbon Emission Reductions Attributable to Grid Connected CDM Projects</i> . Prepared for the UN FCCC. September 19, 2005.	http://cdm.unfccc.int/Panels/meth/meeting/05/Meth17_repan12_BiewaldPaperOMBMMargins.pdf
Boston Globe, "Marshfield to be test site for new energy-saving plan," March 30, 2008.	http://www.boston.com/news/local/articles/2008/03/30/marshfield_to_be_test_site_for_new_energy_saving_plan/
Burkhart, Lori A. "FERC Takes on Reactive Power," <i>Fortnightly's SPARK</i> , March 2005.	http://www.pur.com/pubs/spark/mar05.pdf

References	URL Address
California Public Utilities Commission (CPUC) 2006. Interim Opinion: 2006 Update of Avoided Costs and Related Issues Pertaining to Energy Efficiency Resources. Decision 06-06-063. June 29.	http://www.cpuc.ca.gov/PUBLISHED/COMMENT_DECISION/56572.htm#P86_2251
California PUC 2004. Interim Opinion: Energy Savings Goals for Program Year 2006 and Beyond. Decision 04-09-060, September 23, 2004.	http://www.cpuc.ca.gov/PUBLISHED/FINAL_DECISION/40212.htm
CA PUC 2004. Decision 04-12-048, December 16, 2004.	http://www.cpuc.ca.gov/WORD_PDF/FINAL_DECISION/43224.PDF
California Public Utilities Commission (CPUC) 2005. Interim Opinion: Energy Efficiency Portfolio Plans and Program Funding Levels for 2006-2008 - Phase 1 Issues. Decision 05-09-043. September 22, 2005.	http://www.cpuc.ca.gov/PUBLISHED/FINAL_DECISION/49859.htm
Energy and Environmental Analysis, Inc. 2003. Natural Gas Impacts of Increased CHP. Prepared for U.S. Combined Heat and Power Association. October 2003.	http://www.eea-inc.com/dgchp_presentations/CHP-Gas-Final.ppt
Energy and Environmental Economics, Inc. (E3) and Rocky Mountain Institute (RMI). 2004. Methodology and Forecast of Long Term Avoided Costs for the Evaluation of California Energy Efficiency Programs. Prepared for California Public Utilities Commission Energy Division. October 25.	http://ethree.com/CPUC/E3_Avoided_Costs_Final.pdf See also updates to the initial report: http://ethree.com/cpuc_avoidedcosts.html
EIA Electric Power Monthly, Table 4.13.A: Average Cost of Natural Gas Delivered for Electricity Generation by State.	http://www.eia.doe.gov/cneaf/electricity/epm/table4_13_a.html
Feinstein, C.D., R. Organs, and S.W. Chapel 1997. The Distributed Utility: A New Electric Utility Planning and Pricing Paradigm. Annual Review of Energy and Environment. 22. 155-185.	http://arjournals.annualreviews.org/doi/abs/10.1146/annurev.energy.22.1.155?journalCode=energy
Heschong Mahone Group, Inc. 2005. New York Energy Smart Program Cost Effectiveness Assessment. Prepared for the New York State Energy Research and Development Authority. June.	www.nyserda.org/Energy_Information/ContractorReports/Cost-Effectiveness_Report_June05.pdf
ISO NE, Monthly Summary of Hourly Data (2006)	http://www.iso-ne.com/markets/hstdata/index.html
Jensen, V., and E. Lounsbury. 2005. Assessment of Energy Efficiency Potential in Georgia. Prepared for the Georgia Environmental Facilities Authority by ICF Consulting. May.	http://www.gefa.org/Modules/ShowDocument.aspx?documentid=46
Johnston, L., A. Roschelle, and B. Biewald, "Taking Climate Change into Account in Utility Planning: Zero is the Wrong Carbon Value," Synapse Energy Economics, March 17, 2005.	http://www.synapse-energy.com/Downloads/SynapseReport.2005-03.CACI-HEC.Taking-Climate-Change-into-Account--Zero-is-the-Wrong-Value.04-44.pdf
Kee. 2005. Testimony of Edward D. Kee before the Public Utilities Commission of South Dakota, EL04-16. January 31.	http://www.synapse-energy.com/Downloads/SynapseTestimony.2005-02.SD-PSC-Avoided-Costs-for-the-Java-Wind-Project.04-74.pdf
LaCapra Associates. 2003. Alternatives To Velco's Northwest Vermont Reliability Project. January 29.	http://207.136.225.66/Downloads/Other/VELCO.pdf
Lawrence Berkeley National Laboratory 2002. California Customer Load Reductions during the Electricity Crisis: Did they Help to Keep the Lights On? May 2002.	http://repositories.cdlib.org/cgi/viewcontent.cgi?article=1596&context=lbln

References	URL Address
Lovins, A.B., E. K. Datta, T. Feiler, K. R. Rabago, J.N. Swisher, A. Lehmann, and K. Wicker 2002. Small is Profitable: the Hidden Economic Benefits of Making Electrical Resources the Right Size.	http://www.smallisprofitable.org/
Massachusetts Technology Collaborative (MTC) 2006 (a). Attachment H – Report of Distribution Planning Work Group on DG and Distribution Deferral	http://www.mtpc.org/dg/collab-reports.htm
Massachusetts Technology Collaborative (MTC) 2006. Massachusetts Distributed Generation Collaborative 2006 Report under D.T.E. 02-38-C Investigation by the Department of Telecommunications and Energy on its own Motion into Distributed Generation. June 30, 2006.	http://masstech.org/dg/02-38-C_Attachment-H_DPWG_Report.pdf
NARUC (National Association of Regulatory Utility Commissioners) 1992. Electric Utility Cost Allocation Manual, January 1992.	http://www.naruc.org/Store/
Navigant Consulting Inc. (NCI) 2006. Distributed Generation and Distribution Planning: An Economic Analysis for Massachusetts DG Collaborative. January 20, 2006. Prepared for the Massachusetts Technology Collaborative	http://www.masstech.org/renewableenergy/public_policy/DG/2006-01-23_MTC_Navigant_DG-Economic-Analysis.pdf
NERC. Glossary of Terms.	http://www.nerc.com/files/Glossary_12Feb08.pdf
NRDC (Natural Resources Defense Council) Chang, Audrey. California's Sustainable Energy Policies Provide A Model for the Nation. March 2006.	http://docs.nrdc.org/air/air_06033101a.pdf
Orans, R., Area-Specific Marginal Costing for Electric Utilities: A Case Study of Transmission and Distribution Costs, 1989. PhD Thesis, Stanford University.	N/A
Orans, R., C.K. Woo, J.N. Swisher, B. Wiersma and B. Horii, 1992. Targeting DSM for Transmission and Distribution benefits: A Case Study of PG&E's Delta District, Report No. TR-100487, Electric Power Research Institute.	N/A
Orans R., S. Price, D. Lloyd, T. Foley, E. Hirst 2001. Expansion of BPA Transmission Planning Capabilities. November 2001. Prepared for Transmission Business Line Bonneville Power Administration	http://www.transmission.bpa.gov/PlanProj/bpa_tbl_planning.pdf
Pace Energy and Synapse 2006. A Comprehensive Process Evaluation of Early Experience Under New York's Pilot Program for Integration of Distributed Generation in Utility System Planning. Prepared for The New York State Energy Research and Development Authority. (forthcoming)	http://www.synapse-energy.com/Downloads/SynapseReport.2006-08.NYSERDA.DG-in-New-York-with-Pace-Law-School.04-37.pdf
Pacific Northwest National Laboratory. 2004. <i>Avoiding Distribution System Upgrade Costs Using Distributed Generation</i>	http://gridwise.pnl.gov/docs/pnnlsa39886.pdf
PJM LLC, RTO. 2006(a). "PJM Region Sets Summer's Third Energy-Use Record: Energy Conservation Request Continues East." August 2, 2006.	http://www.pjm.com/about-pjm/newsroom/~media/about-pjm/newsroom/2006-releases/20060802-pjm-sets-third-peak-record.ashx
PJM LLC, RTO. 2006(b). "Early Aug. Demand Response Produces \$650 Million Savings in PJM: Reducing Electricity Use Stretches Power Supplies, Lowers Wholesale Electricity Supplies." August 17, 2006.	http://www.pjm.com/about-pjm/newsroom/~media/about-pjm/newsroom/2006-releases/20060817-demand-response-savings.ashx
Roschelle, A. and W. Steinhurst. (2004) "Best Practices in Procurement of Default Electric Service: A Portfolio Management Approach," Electricity Journal, Oct. 2004	N/A
Shirley W. 2001. For the Regulatory Assistance Project (RAP.) Distribution System Cost Methodologies for Distributed Generation. September 2001.	http://www.raponline.org/Pubs/DRSeries/DistCost.PDF
Stoddard, L., J. Abiecunas, and R. O'Connell. 2006. Economic, Energy, and Environmental Benefits of Concentrating Solar Power in California. Prepared by Black & Veatch for U.S. DOE National Renewable Energy Laboratory. April.	http://www.nrel.gov/docs/fy06osti/39291.pdf

References	URL Address
Synapse Energy Economics 2003. Modeling Demand Response and Air Emissions in New England. August 2003 .	http://www.synapse-energy.com/Downloads/SynapseReport.2003-09.US-EPA.NE-DR-and-AE-Modeling.03-01.pdf
Synapse Energy Economics. 2006. Portfolio Management: Tools and Practices for Regulators, prepared for the national Association of Regulatory Utility Commissioners (NARUC), July 17, 2006.	http://www.synapse-energy.com/Downloads/SynapseReport.2006-07.NARUC.Portfolio-Management-Tools-and-Practices-for-Regulators.05-042.pdf
Tellus Institute 1995. "Costing Energy Resource Options: An Avoided Cost handbook for Electric Utilities," for US EPA and US DOE, September 1995. Shirley W. 2001. For the Regulatory Assistance Project (RAP.) Distribution System Cost Methodologies for Distributed Generation. September 2001 .	http://telluspublications.stores.yahoo.net/energygroup.html

Assessing the Air Pollution, Greenhouse Gas, Air Quality, and Health Benefits of Clean Energy Initiatives

Many states and localities are exploring or implementing clean energy policies to achieve greenhouse gas (GHG) and criteria air pollutant¹ emission reductions.

For example, New Mexico’s Climate Change Advisory Group Action Plan estimates that clean energy measures could achieve more than one-third of the 35 million metric tons of potential carbon dioxide (CO₂) reductions identified in New Mexico in 2020, representing around 15 percent of the projected baseline emissions levels in 2020 (New Mexico Climate Change Advisory Group, 2006). The Metropolitan Washington Council of Governments included renewable energy and energy efficiency measures in its May 2007 State Implementation Plan (SIP) for the 8-Hour Ozone Standard. These measures are expected to avoid almost 150,000 MWh of generation and 0.17 tons of NO_x daily (Metropolitan Washington COG, 2007).

GHG and criteria air pollutant emission reduction estimates are important measures of the potential or realized benefits of clean energy, and are a critical first step for further environmental benefits analysis. Once emitted, some criteria air pollutants are transported in

¹ Criteria air pollutants are particle pollution (often referred to as particulate matter), ground-level ozone, carbon monoxide, sulfur oxides, nitrogen oxides, and lead. The Clean Air Act requires EPA to set National Ambient Air Quality Standards for these air pollutants. EPA calls these pollutants “criteria” air pollutants because it regulates them by developing human health-based and/or environmentally based criteria (i.e., science-based guidelines) for setting permissible levels (U.S. EPA, 2008d).

DOCUMENT MAP

- CHAPTER ONE
Introduction
- CHAPTER TWO
Potential Energy Impacts of Clean Energy
- CHAPTER THREE
Electric System Benefits of Clean Energy
- CHAPTER FOUR
Air Quality Benefits of Clean Energy
- CHAPTER FIVE
Economic Benefits of Clean Energy
- APPENDIX A
Catalogue of Clean Energy Case Studies
- APPENDIX B
Tools and Models Referenced in Each Chapter

CHAPTER FOUR CONTENTS

- 4.1 How Clean Energy Initiatives Result in Air and Health Benefits 95
- 4.2 How States Estimate the GHG, Air, and Health Benefits of Clean Energy 98
 - 4.2.1 Step 1: Develop and Project a Baseline Emissions Profile 98
 - 4.2.2 Step 2: Quantify Air and GHG Emission Reductions from Clean Energy Measures 107
 - 4.2.3 Step 3: Quantify Air Quality Impacts 115
 - 4.2.4 Step 4: Quantify Human Health and Related Economic Effects of Air Quality Impacts 119
- 4.3 Case Studies 124
 - 4.3.1 Texas Emissions Reduction Plan (TERP) 124
 - 4.3.2 Wisconsin – Focus on Energy Program 125
- Information Resources 127
- References 130

the atmosphere potentially for long distances. Some “primary” pollutants are directly harmful to exposed humans and the environment, while other “secondary” pollutants can affect human health after they form as a result of photochemical reactions in the atmosphere. For example, nitrogen oxides (NO_x) and volatile organic compounds (VOCs) react under certain meteorological conditions to form ozone (O₃), a principal component of photochemical smog. Estimating the impact of changes in criteria air pollutant emissions on ambient air quality and the related environmental and health impacts can enhance a state’s understanding of the potential benefits that can result from clean energy measures.²

Understanding a range of environmental and human health benefits from existing and proposed clean energy measures can help state planners:

1. Identify opportunities where meeting today’s energy challenges can serve as an environmental improvement strategy,
2. Potentially reduce the compliance costs of meeting air quality standards by offering more options to states, and
3. Build support for clean energy initiatives among state and local decision makers.

This chapter is designed to help states understand the methods, models, opportunities, and issues associated with assessing the GHG, air pollution, air quality, and human health benefits of clean energy options. While it focuses primarily on emissions from electricity, the methods and tools presented in this chapter could be applied to emissions from other sources.

- Section 4.1, *How Clean Energy Initiatives Result in Air and Health Benefits*, describes the environmental and health benefits of clean energy and addresses several key issues associated with estimating these benefits.
- Section 4.2, *How States Estimate the GHG, Air, and Health Benefits of Clean Energy*, presents four key steps a state can take to estimate the air and health

² By influencing climate change, GHGs can indirectly lead to air quality and health effects. Climate change can lead to more frequent extreme heat events and exacerbate air quality problems through increased temperatures. Methane, which is a key GHG, contributes to ground-level ozone formation. Criteria air pollutants, however, are directly linked to changes in air quality and human health effects in scientific literature. For this reason, this chapter addresses the air quality and human health benefits associated with reducing criteria air pollutant, but not GHG, emissions.

STATES ARE QUANTIFYING THE ENVIRONMENTAL BENEFITS OF CLEAN ENERGY POLICIES

Several states have quantified the emission reductions and air and health benefits from their clean energy measures and determined that the measures are helping them reduce their air pollution and GHGs.

A recent evaluation of The *Wisconsin Focus on Energy Program’s* energy efficiency and renewable energy projects funded by the Utility Public Benefits fund, for example, shows that during the period from program inception in July 2001 through June 30, 2006, the state has displaced annual emissions from power plants and utility customers of about:^a

- 5.8 million pounds of NO_x,
- 2.6 billion pounds of CO₂,
- 11.4 million pounds of SO₂, and
- 46 pounds of mercury (Hg)

In 2004, the Texas Commission on Environmental Quality evaluated the *Texas Emissions Reduction Plan* and calculated that it achieves an annual reduction of NO_x emissions of 346 tons through energy efficiency and renewable energy. NO_x reductions over the period 2007–2012 are projected to range from 824 tons per year in 2007 to 1,416 tons per year in 2012.

Sources: DOA, 2006; Haberl et al., 2007

^a These emission values vary greatly by type of pollutant, due primarily to the content of carbon, sulfur, nitrogen, and mercury in fossil fuels. For example, CO₂ emission reductions from clean energy programs are comparatively high because fossil fuels are rich in carbon, and CO₂ is a primary product of fossil fuel combustion. On the other hand, the concentration of Hg in fuel (primarily coal) is very small, and so emission reductions of Hg are also small compared with reductions of other pollutants.

benefits of clean energy and describes related methods, tools and issues.

- Section 4.2.1, *Step 1: Develop and Project a Baseline Emissions Profile*, focuses on developing and projecting an emissions inventory to establish a baseline from which progress can be measured.
- Section 4.2.2, *Step 2: Quantify Air and GHG Emission Reductions from Clean Energy Measures*, provides guidance on quantifying GHG and criteria air pollutant emission reductions that result from clean energy measures.
- Section 4.2.3, *Step 3: Quantify Air Quality Impacts*, describes how to estimate the changes in air quality that result from air pollution emission reductions.

► Section 4.2.4, *Step 4: Quantify Human Health and Related Economic Effects of Air Quality Impacts*, addresses the quantification of public health impacts based on estimates of air pollution or air quality changes.

▪ Section 4.3, *Case Studies*, presents examples of how two states, Texas and Wisconsin, have estimated the air quality and health benefits resulting from their clean energy programs.

4.1 HOW CLEAN ENERGY INITIATIVES RESULT IN AIR AND HEALTH BENEFITS

Electricity generation from fossil fuels is a major source of many types of air pollution, including GHGs and criteria air pollutants. These emissions contribute to a variety of environmental issues, including global warming and human health problems, which are described below.

GHG emissions occur naturally and absorb some of the heat that would otherwise escape to space (see Figure 4.1.1, *The Greenhouse Effect*). GHGs keep the planet warmer than it would otherwise be through this natural “greenhouse effect.” Human activity-related, or

anthropogenic, GHGs, such as those from electricity generation, are increasing the greenhouse effect and are very likely responsible for most of the observed increase in global average temperatures since the mid-20th century.

The process of generating electricity from fossil fuels is the single largest source of anthropogenic carbon dioxide (CO₂) emissions in the United States, representing 39 percent of CO₂ emissions in 2006 (U.S. EPA, 2008b). GHGs are also emitted during the refinement, processing, and transport of fossil fuels. These gases accumulate and can remain in the atmosphere for decades to centuries, affecting the global climate system for the long term. Measures to reduce GHGs in the near term, therefore, may have a large impact on our ability to meet long-term climate objectives.

Criteria air pollutants affect air quality and human health directly and in the short term. The use of fossil fuels for electric generation causes increased levels of these pollutants in the atmosphere. Some criteria pollutants, including particle pollution (often referred to as particulate matter or PM), carbon monoxide, sulfur dioxide (SO₂) and nitrogen oxides (NO_x), are directly emitted into the atmosphere as the result of fossil fuel combustion. Ozone (O₃) and fine particulate matter

FIGURE 4.1.1 THE GREENHOUSE EFFECT

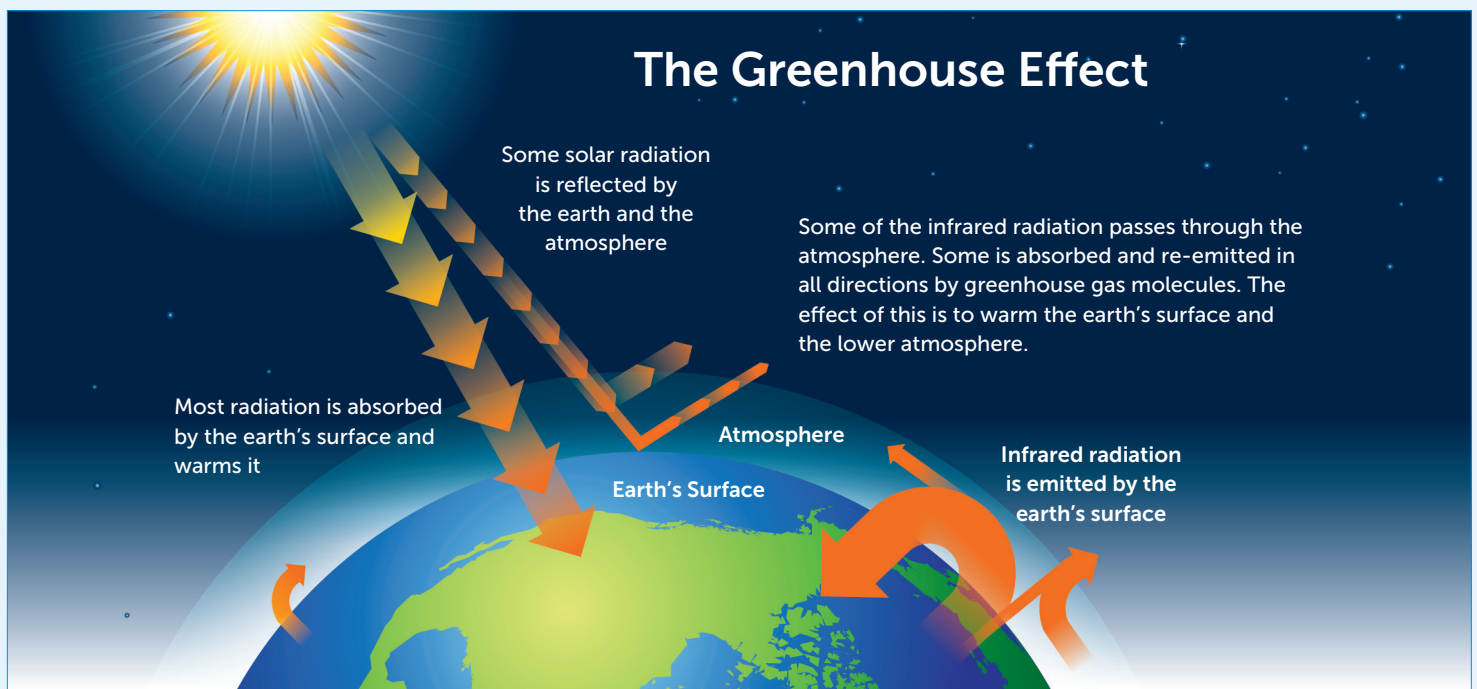

(PM_{2.5}) are “secondary” pollutants that form in the air when directly emitted criteria pollutants and other precursor air pollutants, such as volatile organic compounds (VOCs), react or interact. O₃ and PM_{2.5} are of particular concern because they are most prevalent and are linked with a variety of respiratory and cardiovascular illnesses and death.³

GHGs and criteria air pollutants have different effects on air quality and human health due to their different temporal and spatial characteristics. While GHGs have a global effect and can last more than 100 years, criteria air pollutants have a local to regional effect on air quality and human health, and can dissipate in hours or days. Clean energy measures that reduce criteria air pollutants, therefore, can result in almost immediate local improvements in air quality and human health. In addition, the location and timing of the emissions from criteria air pollutants is very important in determining how significantly they affect human health. Since these pollutants tend to dissipate over time and space, those that occur far away from populations will have less of an impact on human health than those closer to densely populated areas. In contrast, the impact of GHGs on the overall climate system is not affected by the specific location of an emission. One ton of GHG emitted in one location affects the global climate system the same as one ton of the same GHG in a different location.

Clean energy measures reduce the emission of the pollutants described above and related effects on health or the global climate by reducing demand for fossil fuel-based electricity through either:

- Reducing total electric demand through energy efficiency, or
- Directly displacing conventional electricity supplies with clean distributed generation (DG) or renewable energy sources.

The impact of any kind of clean energy resource on air pollutant and GHG emissions and its subsequent effect on human health or global climate change varies depending on the generation sources that are displaced and the resource that is displacing the generation.⁴

³ Tropospheric O₃ also acts as a strong GHG. Different components of PM_{2.5} have both cooling (e.g., sulfates) and warming (e.g., black carbon) effects on the climate system.

⁴ DG and combined heat and power (CHP) units often burn fossil fuels as their primary fuel source. In this case, net emissions (i.e., displaced emissions less the emissions of the DG or CHP unit) also depend on the technology and fuel source for the DG or CHP unit.

FIGURE 4.1.2 NERC INTERCONNECTIONS

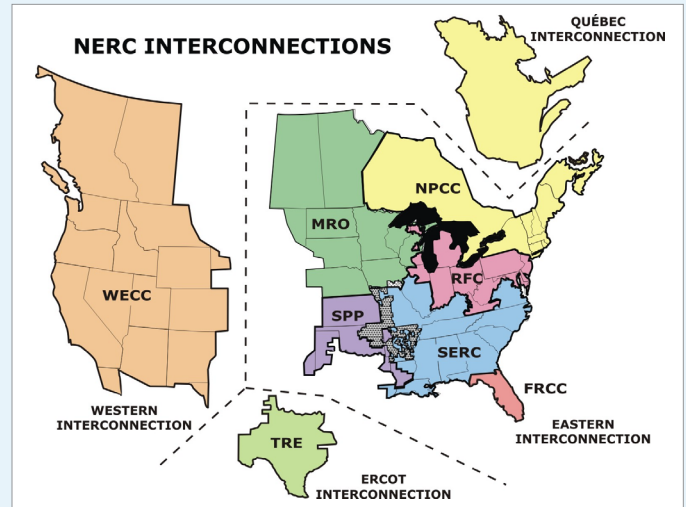

Source: NERC, 2008.

To estimate emission reductions associated with clean energy, it is important to determine which resources are expected to be displaced. This was discussed in detail in Chapter 3 and is repeated here in summary form for completeness. Estimating the emissions associated with the displaced generation presents challenges due to (1) the complex way that electricity is generated and transmitted across the United States and (2) uncertainty about the future location of emissions due to market-based environmental programs such as cap and trade. These challenges are discussed below.

- **Electricity Generation, Transmission, and Distribution.** The continental United States and Canada are divided into four interconnected alternating current (AC) grids (the Eastern, Western, Quebec, and Electric Reliability Council of Texas [ERCOT] Interconnections) as depicted in Figure 4.1.2, *NERC Interconnections*. Each of the grids is electrically isolated with only a limited number of direct current (DC) ties connecting them. However, within each of these grids, electricity is imported or exported continuously among the numerous power control areas.

The demand for electricity varies by season and by time of day. Some power plants—the baseload coal plants and other plants with low variable operating costs such as nuclear and hydroelectric—operate at very high levels. The output of other generators

CLEAN ENERGY AND LEAKAGE

The goal of clean energy policies is typically to reduce emissions within the state or larger region where the policies are implemented. However, due to the interconnected and dynamic nature of the power system, the benefits of clean energy policies may not be completely realized within the region. As utilities and control area operators seek to operate the system to minimize the cost of providing electricity, power transactions occur across the area, both on a long-term contract basis and on a spot basis. As a result, reductions in electricity demand in the region where clean energy policies have been implemented may not always result in corresponding reductions in electricity generation in the same region, depending on the relative cost of this generation and that of neighboring regions.

Reductions in electricity demand levels in the Mid Atlantic region from clean energy policies, for example, might be expected to reduce generation in the Mid Atlantic region. However, if the cost of this now-excess generation in the Mid Atlantic is less than the neighboring regions' marginal sources of generation, it may be economic to use these now-available resources to meet demand in those neighboring regions, thereby displacing more expensive generation. For example, clean energy policies put in place in Pennsylvania may result in reduced emissions in the New England region as lower cost, coal-fired generation is freed up to displace more expensive oil- or gas-fired steam units in New England. The extent of these generation and associated emissions shifts will depend on the cost differential, available transmission capacity, reliability considerations, environmental constraints, and a number of other factors. This shifting of displaced resources from one area to another is often called "leakage" and is an important consideration when assessing the emissions benefits of clean energy programs.

rises and falls throughout the day, responding to changing electricity demand. Other generators are used as "peaking" units and are operated only during the times of highest demand.

A group of system operators across the region decides when and how to dispatch electric generation from each power plant in response to the demand at the time. System operators decide which power plants to dispatch and in what order based on demand at that moment and the cost or bid price. Baseload plants are dispatched first. These plants are typically characterized as having low operating costs, and may be operated at a constant rate. Examples include coal and nuclear plants. Peaking units are dispatched last. These units are typically characterized as having high operating costs, and also have the ability to be dispatched quickly. Examples include natural gas turbines and diesel generators. The fuels, generation efficiencies, control technologies, and emission rates vary greatly from plant

to plant by season and time of day. The emissions effects of energy demand reductions, therefore, also vary by load levels, time of day, and season. As discussed later in this section, the interconnected basis of the system, along with least-cost dispatch practices, has implications for the impacts of the effectiveness of clean energy programs in the region in which they are implemented. Specifically, there is potential for generation and emissions leakage from the implementing region to neighboring regions if specific measures are not taken to limit this.

Other conditions besides demand and cost affect dispatch. Transmission constraints, when transmission lines become congested, can make it difficult to dispatch power from far away into areas of high electricity demand. Extreme weather events can decrease the ability to import or export power from neighboring areas. "Forced outages," when certain generators are temporarily not available, can also shift dispatch to other generators. System operators must keep all these issues in mind when dispatching power plants. For more information about how the electric system works, see Section 3.1, *How Clean Energy Can Achieve Electric System Benefits*.

- **Air Emission Cap and Trade Programs.** Air emission cap and trade programs, such as the Acid Rain Program,⁵ set annual limits (i.e., caps) on fossil-fuel-fired electric generators' emissions and play an important role in ensuring that air pollutant emissions are reduced.

Under cap and trade programs, each utility or generator typically receives a certain number of allowances, each of which is an authorization to emit one ton of a specific air pollutant (e.g., SO₂). A generator must obtain enough allowances to cover its emissions. If a generator has excess allowances, due, for example, to the installation of air pollution control devices, it can bank the allowances for later use or sell the allowances to another company, depending upon the specific program rules. If a generator does not expect to have enough allowances to authorize its emissions, it can buy allowances, install emissions controls, or curtail its activity.

The trading component of the cap and trade program allows for the most cost-effective emission reductions to occur first. If the demand for

⁵ The Acid Rain Program regulates SO₂ and NO_x emissions in the continental United States to reduce acid deposition caused by these emissions.

allowances decreases or the supply of excess allowances increases (e.g., because clean energy measures result in reduced fossil-fuel-fired electricity generation) the cost of achieving the cap decreases, but the cap itself does not change. While cap and trade programs ensure a certain reduced level of emissions and can result in a more diversified energy system, trading emission allowances means that it can be difficult to attribute emission reductions to specific clean energy measures, and that in some cases clean energy measures may not result in net emission reductions at all.

Despite these challenges, tools and methods exist for states to address these issues and estimate air emission reductions, air quality changes, and human health effects associated with clean energy policies. These approaches are described below in Section 4.2, *How States Estimate the GHG, Air and Health Benefits of Clean Energy*.

4.2 HOW STATES ESTIMATE THE GHG, AIR, AND HEALTH BENEFITS OF CLEAN ENERGY

Analysis to quantify the greenhouse gas, air pollution, air quality, and human health benefits of clean energy initiatives involves four basic steps:

1. Develop and project a baseline emissions inventory,
2. Quantify the air and GHG emission reductions from the clean energy measures,
3. Estimate the changes in air quality resulting from these emission reductions, and
4. Estimate the human health and related economic effects of these air quality changes.

These steps often occur linearly, as shown in Table 4.2.1, *Steps for Estimating GHG, Air, and Health Benefits of Clean Energy Initiatives*. This is because estimating some of the benefits, such as improved air quality and reduced human health effects, requires information generated in previous steps—specifically the timing and type of generation displaced by the clean energy measures.

Some states may not be interested in estimating all of the benefits described in this section, or they may not achieve benefits in each area. For example, as described in Section 4.1, *How Clean Energy Initiatives Result in Air and Health Benefits*, while criteria air pollutants

GUIDANCE ON CREDITS FOR EMISSION REDUCTIONS FROM CLEAN ENERGY

EPA has developed a State Implementation Plan (SIP) guidance document that provides a step-by-step procedure for quantifying the benefits. It describes the following two options for state and local governments to address the presence of a cap and trade program when quantifying emission reductions from clean energy:

- Retire commensurate amount of allowances, or
- Demonstrate that an emission or air quality benefit is expected to occur even in the presence of such a cap and trade program.

Source: U.S. EPA, 2004.

are linked directly with air quality changes and human health effects, greenhouse gas emissions are indirectly linked to air quality and human health effects.⁶ Thus, if a state clean energy policy yields GHG impacts but very low criteria air pollutant impacts, it may not be worthwhile to continue evaluating the air quality and subsequent health impacts because they likely would be negligible.

The remainder of this section describes basic and sophisticated modeling approaches, and related protocols, data needs, tools, and resources that states can use during each step in the process of quantifying the GHG, air, and human health benefits of clean energy initiatives.

4.2.1 STEP 1: DEVELOP AND PROJECT A BASELINE EMISSIONS PROFILE

The initial step in measuring clean energy emissions reductions is to prepare a state-level emissions inventory and projection that documents the baseline, or the emissions that occur without any additional clean energy policies. This baseline can include historical, current, and projected emissions data and provides a clear reference case against which to measure the emission impacts of a clean energy initiative.

Emissions inventories and projections are typically created for criteria air pollutants to support air quality attainment planning, or for GHGs to support climate change action plans, but do not necessarily include both GHGs and criteria air pollutants. However, an inventory that includes both types of emissions will

⁶ Nevertheless, clean energy measures that reduce GHGs may also reduce criteria air pollutants, thus resulting in direct health benefits.

TABLE 4.2.1 STEPS FOR ESTIMATING GHG, AIR, AND HEALTH BENEFITS OF CLEAN ENERGY INITIATIVES

Step 1.	Step 2.	Step 3.	Step 4.
Develop and Project a Baseline Emissions Profile (Section 4.2.1)	Quantify Air and GHG Emission Reductions from Clean Energy Measures (Section 4.2.2)	Quantify Air Quality Impacts (if any) (Section 4.2.3)	Quantify Human Health and Related Economic Effects of Air Quality Impacts (Section 4.2.4)
Criteria Air Pollutants			
<p>a. Select method.</p> <p>b. Compile criteria air pollutants from available sources into inventory.</p> <p>c. Develop a forecast using assumptions about future and available tools.</p>	<p>a. Develop criteria air pollutant reductions from clean energy using:</p> <ul style="list-style-type: none"> ▪ energy savings estimates, ▪ operating characteristics of clean energy resource (load profile), ▪ emissions factors, and ▪ control technology data. <p>Compare against the baseline.</p>	<p>Use criteria air pollutant data to estimate changes in air quality with an air quality model.</p>	<p>a. Use data on air quality changes and epidemiological and population information to estimate health effects.</p> <p>b. Apply economic values of avoided health effects to monetize benefits.</p>
Greenhouse Gas Emissions			
<p>a. Select method.</p> <p>b. Compile greenhouse gas emissions from available sources into inventory.</p> <p>c. Develop a forecast using assumptions about future and available tools.</p>	<p>a. Develop greenhouse gas emission reductions from clean energy using:</p> <ul style="list-style-type: none"> ▪ energy savings estimates and a profile of when these impacts will occur, ▪ operating characteristics of clean energy resource, ▪ emissions factors, and ▪ fuel data. <p>b. Compare against the baseline.</p>	n/a	n/a

facilitate a more comprehensive analysis of the emissions benefits of clean energy and the value of clean energy policies. This is important because many options that reduce GHGs may, in fact, reduce criteria air pollutants and indirectly yield health benefits. On the other hand, some measures that reduce GHG emissions can actually increase emissions of criteria air pollutants.

For example, a measure that encourages switching from electricity generated with natural gas to electricity generated by wind will result in both criteria air pollutant benefits and GHG emission reductions. The impact on air pollution is less certain, however, if a state switches from natural gas to biomass-generated energy. It is important to take these considerations into account when evaluating the air and health benefits

of clean energy measures. Developing a baseline that includes both GHGs and criteria air pollutants serves as a future point of reference for retrospective program evaluation as well as a basis for making well-informed policy and planning decisions.

Typically, a state’s air agency creates the criteria air pollutant inventory every three years as part of its responsibility to meet National Ambient Air Quality Standards established under the Clean Air Act. GHG emissions inventories can be developed by state air or other agencies, but since states are not required by federal law to inventory their GHG emissions, the practice varies from state to state. State energy offices or universities sometimes develop GHG inventories on an annual basis or every few years. If inventories

SOURCES OF AIR POLLUTION EMISSIONS

Air emission sources are grouped into four categories: point, area, mobile (on-road and non-road), and biogenic sources. Each is described below.

Point Source: A stationary location or fixed facility from which pollutants are discharged, such as an electric power plant or a factory smokestack.

Area Source: An air pollution source that is released over a relatively small area but cannot be classified as a point source. Area sources include small businesses and household activities, product storage and transport distribution (e.g., gasoline), light industrial/commercial sources, agriculture sources (e.g., feedlots, crop burning), and waste management sources (e.g., landfills). Emissions from area sources are generally reported by categories rather than by individual source.

On-Road Mobile Source: Sources of air pollution from highway vehicles such as cars and light trucks, heavy trucks, buses, engines, and motorcycles.

Non-Road Mobile Source: Pollutants emitted by combustion engines not associated with highway vehicles, such as farm and construction equipment, gasoline-powered lawn and garden equipment, power boats and outboard motors, and aircraft.

Biogenic Sources: Emissions produced by living organisms, such as a forest that releases hydrocarbons.

Sources: Texas Commission on Environmental Quality, 2008; U.S. EPA, 2008.

EMISSIONS FACTOR APPROACH

An emissions factor quantifies the amount of a pollutant released to the atmosphere from a "unit" of an activity or source (e.g., lbs CO₂ per therm CH₄ burned). The emissions estimates are calculated by multiplying the emissions factor (e.g., pounds of NO_x per kWh produced) by the activity level (e.g., kWh produced). Emissions factors can be calculated based on the chemical composition of the fuels burned or determined by emissions monitors.

Emissions factors for CO₂, NO_x, SO₂, and other pollutants are available from:

- **EPA's Emissions Factors and Policy Applications Center**
<http://www.epa.gov/ttn/chief/efpac/.html>
- **EPA's Emissions & Generation Resource Integrated Database (eGRID)**
<http://www.epa.gov/egrid>
- **EPA's U.S. Greenhouse Gas Inventory Reports**
<http://www.epa.gov/climatechange/emissions/usinventoryreport.html>
- **Intergovernmental Panel on Climate Change Emissions Factor Database (EFDB)**
<http://www.ipcc-nggip.iges.or.jp/EFDB/main.php>

are available, states can use them in their assessment of clean energy policies rather than develop a new baseline emissions inventory. Sources of completed state and local inventories that states and localities can adopt for use in their analyses include:

- **EPA State GHG Inventories:** EPA maintains a Web site on state GHG inventories, which includes a table of state CO₂ emissions from fossil fuel consumption by sector. http://epa.gov/climatechange/emissions/state_energyco2inv.html

Links to maps and summaries of existing state-compiled greenhouse gas inventories are also available on this Web site.⁷ http://epa.gov/climatechange/emissions/state_ghginventories.html

- **Local Government Inventories.** Many local governments have compiled GHG and/or criteria air pollutant inventories through the auspices of ICLEI's Cities for Climate Protection or the U.S.

⁷ State CO₂ estimates are based on state energy data from the Energy Information Administration (EIA), which maintains a database of state energy-related data including fuel consumption by sector, electricity consumption, and forecasts of the electric generation sector (U.S. DOE, 2008b).

Conference of Mayor's Climate Protection Agreement. These inventories have typically been developed using the CACPS Tool described below. Many of these local inventories can be found online.

- **National Emissions Inventory (NEI).** States can use the NEI to help establish an inventory of criteria and hazardous pollutants. EPA prepares a national database of air emissions information with input from numerous state and local air agencies, tribes, and industry. The database contains information on stationary and mobile sources that emit criteria air pollutants and their precursors, as well as hazardous air pollutants (HAPs). The database also includes estimates of annual emissions, by source, of air pollutants in each area of the country. The NEI includes emission estimates for all 50 states, the District of Columbia, Puerto Rico, and the Virgin Islands, and is updated every three years. <http://www.epa.gov/ttn/chief/eiinformation.html>

If existing baseline inventories are not available, states can develop their own using methods and tools described below.

Approaches to Developing a Baseline Emissions Inventory

There are two basic approaches for developing state emissions inventories for criteria air pollutants and/or GHGs: top-down and bottom-up approaches. Both inventory approaches require energy use estimates and emissions factors to convert estimates of energy use into estimates of emissions, as described in the text box *Emissions Factor Approach*. Top-down and bottom-up approaches vary in their level of data and aggregation and can serve different purposes. While the inventory development process can be time- and resource-intensive, it does not necessarily entail complex modeling methods.

Table 4.2.2, *Comparison of Top-Down and Bottom-Up Approaches for Developing a Baseline Air and/or GHG Emissions Inventory and Projection*, compares the key aspects of top-down and bottom-up approaches. The

following section presents information about each approach for developing an emissions inventory, including their strengths and weaknesses, appropriate applications, relevant data sources and resources, and the tools available to states. Methods and approaches for projecting inventories out into the future are also described. For further information on described tools, see the Information Resource Description table at the end of this chapter.

Top-Down Inventory Development

A top-down inventory contains aggregated activity data across the state or community, and is used to generate state-wide estimates of emissions of GHGs or criteria air pollutants. For example, a top-down inventory might report emission estimates for categories such as an industry within a state; it would not contain data on emissions from specific facilities or buildings.

TABLE 4.2.2 COMPARISON OF TOP-DOWN AND BOTTOM-UP APPROACHES FOR DEVELOPING A BASELINE AIR AND/OR GHG EMISSIONS INVENTORY AND PROJECTION

Tools	Protocols	Advantages	Disadvantages	When to Use this Method
Top-Down Inventory				
<ul style="list-style-type: none"> EPA's State Inventory Tool for GHGs. National Association of Clean Air Agencies (NACAA) and International Council for Local Environmental Initiatives (ICLEI) Clean Air and Climate Protection Software (community- or state-wide inventory). 	<ul style="list-style-type: none"> Intergovernmental panel on Climate Change. EPA's Emissions Inventory Improvement Program. 	<ul style="list-style-type: none"> Can capture all emissions in a state. Reliable data are available for most major sources. 	<ul style="list-style-type: none"> Does not provide in-depth sectoral emission detail. Use of state average factors may lead to some uncertainty or error in estimates. Lacks spatial resolution needed for air quality modeling. 	<ul style="list-style-type: none"> State-wide estimates of emissions. State-wide GHG inventories. Area source emission estimates for criteria air pollutants.
Bottom-up Inventory				
<ul style="list-style-type: none"> NACAA and ICLEI's Clean Air and Climate Protection Software (government operations inventory). Emission Reporting Data (e.g., Acid Rain Program Data, or facility specific emission reports). 	<ul style="list-style-type: none"> EPA Climate Leaders GHG Inventory Protocol. The World Resources Institute (WRI) and World Business Council on Sustainable Development (WBCSD) GHG Protocol. California Registry Protocols. The Climate Registry. 	<ul style="list-style-type: none"> Can provide more detailed or nuanced profile of emissions. Allows analysis of indirect emissions sources (purchased electricity, etc). 	<ul style="list-style-type: none"> Requires highly disaggregated data which may be difficult to obtain. May not capture all emissions in a state. 	<ul style="list-style-type: none"> Sector-specific GHG inventories. Stationary source emission estimates for criteria air pollutants. When data required for top-down inventory are not available.

GHG REGISTRIES

GHG registries are systems for quantifying and reporting GHG emissions and/or activities to reduce emissions that are developed by collaborations of organizations, such as states or firms. By establishing consistent emission reporting protocols, a registry provides a common framework for entities to complete a GHG inventory of their own emissions or emissions reductions and a credible repository for the data over time. Such a collection of entity-level emissions data can help inform a state's understanding of emission sources and activities being taken to reduce emissions. A registry does not serve the same function as an inventory since it does not provide a comprehensive or complete set of data on all emissions sources.

Examples of registry efforts are:

- **The Climate Registry** is a collaboration among states, provinces, and tribes to develop a common greenhouse gas emissions registry system across multiple governments. Corporations with operations in multiple states will be able to report emissions using a consistent reporting protocol and management system. <http://www.theclimateregistry.org/>.
- **The California Climate Action Registry (CCAR)** was established by California statute as a registry for GHG inventories for corporate reporting within the state. CCAR has developed a general protocol and additional industry-specific protocols that give guidance on how to inventory GHG emissions for participation in the Registry. <http://www.climateregistry.org/>
- **The Voluntary Reporting of GHG Program** is a mechanism by which corporations, government agencies, individuals, and organizations can report their GHG emissions, emission reductions, and sequestration activities to the federal Energy Information Agency. It was established under Section 1605(b) of the Energy Policy Act of 1992. <http://www.eia.doe.gov/oiaf/1605/index.html>
- **EPA's Mandatory GHG Reporting Rule**, as requested by Congress under the FY2008 Consolidated Appropriations Act, became effective December 29, 2009. It requires sources above certain threshold levels monitor and report GHG emissions and applies to fossil fuel suppliers and industrial gas suppliers, direct GHG emitters and manufacturers of heavy-duty and off-road vehicles and engines. http://www.epa.gov/climatechange/emissions/ghg_rulemaking.html

Because the spatial characteristics of criteria air pollutants are important, an ideal inventory would include very detailed, source-specific data that can be used in air quality modeling. However, some sources, such as area sources (e.g., residential fuel use and industrial use of paints, solvents, and consumer products), cannot be easily attributed to individual sectors or sources and lend themselves more appropriately to a top-down

approach.⁸ See the text box *Sources of Air Pollution Emissions* above for a summary of the different sources.

While there may be circumstances where a state desires significant detail about the sources of its GHG emissions, GHG inventories do not require the same level of detailed spatial resolution since, as described above, a ton of GHGs in one part of the state affects global climate change in the same way as a ton of the same GHG in another part of the state. For GHG emission inventories, the top-down approach is most appropriate when developing state-wide estimates of emissions and developing emission reduction targets.

Protocols

It is important to develop an inventory that adheres to a comprehensive and detailed set of methodologies for estimating emissions. For GHG emissions, these methodologies are usually derived from standards established by the Intergovernmental Panel on Climate Change (IPCC, 2008). Specific methods, tools, and protocols for developing top-down baseline GHG emissions inventories, forecasting future emissions, and tracking changes are available at both the state and local levels. For criteria air pollutants, these methodologies are usually derived from standards established by EPA's Emissions Inventory Improvement Program (EIIP), which offers guidance for developing inventories of criteria and hazardous air pollutants and greenhouse gas emissions (EPA, 2007). The protocols vary depending on the type of inventory data a state collects.

Data Needs

To complete a top-down state-wide energy-related emissions inventory, a state needs a variety of data, such as state-wide electricity generation; energy consumption by sector; and coal, oil, and natural gas production and distribution.⁹ Many of these data are available from national sources, such as the Energy Information Agency (EIA) State Energy Data System (U.S. DOE, 2008a). Data on economic activity and human population levels may be needed to supplement data sources. These data are also available from national sources such as the Bureau of Economic Analysis'

⁸ Mobile sources are included as a separate category from area sources in typical air pollution inventories.

⁹ To expand the inventory beyond energy, states would need data on sources such as agricultural crop production, animal populations, and fertilizer use; waste generation and disposal methods; industrial activity levels; forestry and land use; and wastewater treatment methods.

Regional Accounts and the Census Bureau Population Estimates. Some tools, such as the State Inventory Tool, described below, provide default values states can use. Additional sources are described later in this section.

Tools

Tools to help state and local governments develop GHG and criteria air pollutant emission inventories include:

- *EPA's State Inventory Tool.* States can use EPA's State Inventory Tool to develop top-down GHG inventories. This interactive spreadsheet software tool is based on IPCC guidelines. States can enter their own data or use pre-loaded state-specific emissions factors and activity levels from federally managed databases, such as EPA's eGRID (<http://www.epa.gov/egrid>) and DOE's EIA. The State Inventory Tool can calculate GHG emissions from energy consumption as well as from industrial processes, agriculture, forestry, and waste management. This tool is generally used to develop state-wide inventories that can be tracked over time, to determine sectors a state might target for reductions and to measure long-term progress against state-wide or community-wide goals over time. The State Inventory Tool is designed to generate inventories for each year in a time series (currently 1990–2006). http://www.epa.gov/climatechange/emissions/state_guidance.html
- *Clean Air and Climate Protection Software Tool.* Local governments can use the *Clean Air and Climate Protection Software (CACPS)* tool to develop a top-down inventory of both criteria air pollutants and GHGs associated with electricity, fuel use, and waste disposal. CACPS is a Windows-based software tool and database developed by the National Association of Clean Air Agencies (NACAA)¹⁰ and the International Council for Local Environmental Initiatives (ICLEI), with EPA funding. The 2005 version of the tool is provided free to state and local governments. More recent versions can be purchased from ICLEI.

While available to state as well as local governments, the CACPS tool is most appropriate for developing locality-wide or government operations GHG inventories based on IPCC guidelines with the inclusion of criteria air pollutants. The CACPS tool:

- is based on end-use energy consumption and excludes agriculture, forestry, industrial, and energy production;
- requires users to complete each inventory year separately; and
- allows for analysis of indirect emissions (e.g., electricity imported from another state, waste sent to out-of state landfills).

It is important to note, however, that CACPS does not include location-specific criteria air pollutant inventories and so it is difficult to interpret air quality impacts. <http://www.cacpssoftware.org/>

Bottom-up Inventory Development

While top-down inventories are developed using high-level, aggregated energy and economic information, bottom-up inventories are built from source, equipment population, and activity data. Bottom-up inventory development involves collecting information on source number and type from individual entities (e.g., businesses, local governments) within the state. This approach can supplement state-wide GHG and other air pollutant emission inventories by providing additional, more detailed information. Data collected in this manner may provide a more accurate estimate of emissions within particular sectors (e.g., state-owned government buildings). A more detailed and time consuming method than the top-down approach, bottom-up inventory development provides comprehensive estimates of precursor emissions and details regarding spatial and temporal attributes that are required for air quality modeling applications.

For criteria air pollutant inventories, bottom-up inventories are most appropriate for developing more accurate estimates for on-road, non-road, and stationary source emissions that can easily be attributed to individual sectors or sources (e.g., major industrial and commercial emission sources, such as electricity generators, manufacturing processes and chemical processes). For GHG emission inventories, the bottom-up approach is most appropriate when developing sector-specific inventories, when the data required for a top-down inventory are not available, or to provide a better match when evaluating multi-pollutant controls.

Protocols

As with the top-down inventory, it is important to develop a bottom-up inventory that adheres to a

¹⁰ Formerly the State and Territorial Air Pollution Program Administrators and Association of Local Air Pollution Control Officials (STAPPA/ALAPCO).

comprehensive and detailed set of methodologies for estimating emissions. For GHG emissions, there are several protocols that states can use, including:

- *EPA Climate Leaders GHG Inventory Protocol.* The Climate Leaders Protocol includes overall guidance to corporations in the Climate Leaders Partnership on issues such as defining inventory boundaries, identifying GHG emission sources, defining and adjusting a base year, reporting requirements, and goal-setting. <http://www.epa.gov/climateleaders>
- *The GHG Protocol.* The GHG Protocol is a joint effort of the World Resources Institute (WRI) and the World Business Council on Sustainable Development (WBCSD). The protocol was designed for corporate inventories, but can be adapted for use by state governments quantifying emissions from their own operations. The protocol provides step-by-step guidance on calculating GHG emissions from specific sources (e.g., stationary and mobile combustion, process emissions) and industry sectors (e.g., cement, pulp and paper aluminum, iron and steel, and office-based organizations). <http://www.ghgprotocol.org/>
- *Local Government Operations Protocol for the Quantification and Reporting of Greenhouse Gas Emissions Inventories, released in September 2008.* The Local Government Operations Protocol was created to help local governments develop consistent and credible emission inventories based on internationally accepted methods. Developed in partnership by the California Air Resources Board, California Climate Action Registry, ICLEI - Local Governments for Sustainability, and The Climate Registry, it involved a multi-stakeholder technical collaboration that included national, state, and local emissions experts. <http://www.iclei.usa.org>

For criteria air pollutants, methodologies are usually derived from standards established by EPA's EIIP program, which offers guidance for developing inventories of criteria and hazardous air pollutants. <http://www.epa.gov/ttn/chief/eiip/techreport/>

Data Needs

Bottom-up inventories are data-intensive. Often data are not as readily available from national databases as for top-down inventories and thus may require a significant level of effort and time to collect. To conduct a bottom-up GHG inventory of the utility sector, for

example, a state would collect data on the fossil fuel consumption of every electricity production site in the state and convert it to GHG quantities based on the carbon content of the specific fuels that were used. Alternatively, for sources for which data exist, a state can gather and analyze continuous emissions monitoring (CEM) data for electric utilities.

If a state is interested in developing an inventory of its operations-related emissions, it would collect and compile data on its energy and electricity use, process emissions, waste generated, and other emissions-generating activities. These data are often obtained from utility bills, fleet records, and similar records.

Bottom-up criteria air pollutant inventories typically use data gathered through surveys and reports from emission sources, source permits, stack test data, and CEM data. As described above, while obtaining data can be difficult, the bottom-up approach can yield a more detailed or nuanced profile of emissions for a particular sector than a top-down approach. More information about existing data sources is provided below.

Tools

States can use a variety of tools to help develop bottom-up GHG and criteria air pollutant inventories.

For GHG inventories:

- *Portfolio Manager* is a free, interactive ENERGY STAR energy management tool that enables users to track and assess energy and water consumption for a single building or across a portfolio of buildings. A new feature of Portfolio Manager lets users see how their buildings' CO₂ emissions compare with other buildings in the same region and across the country, and measure their progress in reducing emissions. The tool can be used to identify buildings with the most potential for energy efficiency improvements. http://www.energystar.gov/index.cfm?c=evaluate_performance.bus_portfoliomanager_carbon

For criteria air pollutant inventories:

- **Point Sources:** Most criteria pollutant inventories for point sources are developed from permits and other facility data rather than from a series of tools. One tool that may complement this approach is the *Landfill Gas Emissions Model* (LandGEM), a free, automated estimation tool with a Microsoft Excel

interface that can be used to estimate emission rates for total landfill gas, methane, CO₂, nonmethane organic compounds, and individual air pollutants from municipal solid waste landfills. <http://www.epa.gov/ttn/catc/dir1/landgem-v302-guide.pdf>

- Mobile Sources: Inventories for on-road and non-road mobile sources can be aided by tools such as:
 - *MOBILE6*, a computer program that estimates emission rates for mobile pollutants such as hydrocarbon (HC), carbon monoxide (CO), oxides of nitrogen (NO_x), exhaust particulate matter (which consists of several components), tire wear particulate matter, brake wear particulate matter, sulfur dioxide (SO₂), ammonia (NH₃), six hazardous air pollutants (HAPs), and carbon dioxide (CO₂). *MOBILE6* focuses on gasoline-fueled and diesel highway motor vehicles, and for certain specialized vehicles such as natural-gas-fueled or electric vehicles that may replace them. *MOBILE6* uses county or link-level VMT, speed, registration, and roadway classification data to estimate emissions from motor vehicles. <http://www.epa.gov/OMS/m6.htm>
 - *NON ROAD 2005* calculates past, present, and future emission inventories (i.e., tons of pollutant) for all nonroad vehicle and equipment categories (e.g., recreational vehicles, agricultural equipment, industrial equipment) except commercial marine, locomotives, and aircraft. The fuel types included in the model are gasoline, diesel, compressed natural gas, and liquefied petroleum. The model estimates exhaust and evaporative HC, CO, NO_x, particulate matter, SO₂, and CO₂ emissions. The user can select a specific geographic area (i.e., national, state, or county) and time period (i.e., annual, monthly, seasonal, or daily) for analysis. The *NONROAD* tool includes estimates of equipment population and activity and appropriate emissions factors to estimate emissions from these types of sources. <http://www.epa.gov/oms/nonrdmdl.htm>
 - *Motor Vehicle Emission Simulator (MOVES)* is a replacement for *MOBILE6* and *NONROAD* that EPA is currently developing. This new emission modeling system will estimate emissions for on-road and nonroad mobile sources, cover a broad range of pollutants, and allow

multiple scale analysis—from fine-scale analysis to national inventory estimation. When fully implemented, *MOVES* will serve as the replacement for *MOBILE6* and *NONROAD* for all official analyses associated with regulatory development, compliance with statutory requirements, and national/regional inventory projections. <http://www.epa.gov/otaq/models/moves/index.htm>

Data Sources and Additional Resources for Top-Down and Bottom-Up Inventories

Many sources of data exist that states can use as they compile top-down or bottom-up inventories. Some of these data sources focus specifically on criteria air pollutants, some focus on GHGs, and some include both. Other sources provide already-compiled emissions estimates. These resources are listed in Table 4.2.3 and described below.

- *Emissions & Generation Resource Integrated Database (eGRID)*. This free, publicly available software from EPA has data on annual SO₂, NO_x, CO₂, and Hg emissions for most power plants in the United States. *eGRID* also provides annual average non-baseload emission rates, which may better characterize the emissions of load-following resources.¹¹ By accessing *eGRID*, states can find detailed emissions profiles for every power plant and electric generating company in the United States. <http://www.epa.gov/egrid>
- *Emissions Collection and Monitoring Plan System (ECMPS)*. EPA collects data in five-minute intervals from Continuous Emissions Monitors (CEMS) at all large power plants in the country. The *ECMPS* is a new system of reporting emissions data, monitoring plans, and certification data, and replaces the *Emission Tracking System (ETS)* that previously served as a repository of SO₂, NO_x, and CO₂ emissions data from the utility industry. <http://www.epa.gov/airmarkets/business/>
- *WRI Climate Analysis Indicators Tool: The Climate Analysis Indicators Tool (CAIT–U.S.)* provides a free, comprehensive, and comparable database of GHGs and other climate-relevant indicators for U.S. states. <http://cait.wri.org/>

¹¹ “Load-following” refers to the order in which different types of generating equipment are used to meet changing electricity demand.

TABLE 4.2.3 SOURCES OF AIR POLLUTANTS AND GHG EMISSIONS DATA, INVENTORIES

Data Source	Type of Air Pollutant or GHG Emissions					Approach	
	SO ₂	NO _x	CO ₂	Other GHGs	Hg	Top-Down	Bottom-Up
National Emissions Inventory (NEI)	x	x			x	x	x
eGRID	x	x	x	x	x	x	x
Emissions Collection and Monitoring Plan System (ECMPS)	x	x	x				x
World Resources Institute Climate Analysis Indicators Tool			x	x		x	
EPA State GHG Inventories			x	x		x	
Local GHG Inventories			x	x		x	

- *State Agencies and Universities:* Many state agencies and universities collect emissions and/or energy data within their state, which can be compiled into an inventory.

Forecasting Future Emissions

To conduct a prospective analysis of potential emission reductions from a future policy, it is necessary to develop forecasts of both the new policy case and the “business as usual” (BAU) case that does not include the new policy.¹² Emission projections provide a basis for:

- Developing control strategies for State Implementation Plans (SIPs) or mitigation measures for Climate Change Action Plans;
- Conducting air quality attainment analyses; and
- Tracking progress toward meeting air quality standards or GHG reduction goals.

When developing emission projections, an attempt is made to account for as many of the important variables that affect future year emissions as possible. States can project future emissions based on historic trends and expectations about numerous factors, including projections of population growth and migration, economic growth and transformation, fuel availability and prices, technological progress, changing land-use patterns,

¹² When conducting a prospective analysis of clean energy policies that have already been implemented, a forecast of emissions is not necessary although it could facilitate projecting the future benefits of existing programs. For a retrospective analysis, the impacts of the existing clean energy program could be backed out of the forecast and reintroduced to estimate the impacts.

and climate change.¹³ The degree to which any of these specific drivers is important is a function of the projection horizon. For example, climate change impacts may be negligible for a five- to ten-year projection.

Several guidance documents and tools are available to help states understand methodologies and data sources for factors relevant to projections, including:

- *EPA EIIP Technical Report Series, Volume X: Emissions Projections.* This document provides information and procedures to state and local agencies for projecting future air pollution emissions for the point, area, and onroad and nonroad mobile sectors. It describes data sources and tools states might use for their projections. <http://www.epa.gov/ttn/chief/eiip/techreport/volume10/x01.pdf>
- *EPA State GHG Projection Tool.* States can use this EPA spreadsheet tool to create forecasts of BAU GHG emissions through 2020. Future emissions are projected using a combination of linear extrapolation of the results from the State Inventory Tool, described above, combined with economic, energy, population, and technology forecasts. The tool can be customized, allowing states to enter their own assumptions about future growth and consumption patterns. <http://www.epa.gov/climatechange/wycd/stateandlocalgov/analyticaltools.html>

¹³ Some of these factors are closely related, and will rely on specific components of these trends that may include electricity imports and exports, power plant construction or retirement, domestic vs. imported agricultural production, waste production, number of road vehicles, tons of freight transported, vehicle miles traveled, and environmental regulations.

TABLE 4.2.4 COMPARISON OF BASIC AND SOPHISTICATED APPROACHES FOR QUANTIFYING AIR POLLUTANT AND GHG EMISSION EFFECTS OF CLEAN ENERGY INITIATIVES

Tools	Advantages	Disadvantages	When to Use this Method
Basic Approaches			
<ul style="list-style-type: none"> ▪ eCalc ▪ OTC Workbook^a ▪ CACPS 	<ul style="list-style-type: none"> ▪ Transparent. ▪ Modest level of time, technical expertise, and labor required. ▪ Inexpensive. 	<ul style="list-style-type: none"> ▪ May be imprecise. ▪ May be inflexible. ▪ May have embedded assumptions that have large impacts on outputs. 	<ul style="list-style-type: none"> ▪ Preliminary studies for short-term resource planning. ▪ Designing new programs and evaluating existing ones. ▪ Regulatory compliance and energy plans.
Sophisticated Approaches			
<ul style="list-style-type: none"> ▪ ENERGY 2020 ▪ NEMS ▪ IPM ▪ MARKAL ▪ PROSYM ▪ GE MAPS ▪ PROMOD 	<ul style="list-style-type: none"> ▪ More rigorous than basic modeling methods. ▪ May be perceived as more credible than basic modeling methods. ▪ Allows for sensitivity analysis. ▪ May explicitly account for and quantify leakage. 	<ul style="list-style-type: none"> ▪ Less transparent than spreadsheet methods. ▪ Labor- and time- intensive. ▪ Often high software licensing costs. ▪ Requires assumptions that have large impact on outputs. ▪ May require significant technical experience. 	<ul style="list-style-type: none"> ▪ State Implementation Plans. ▪ Late-stage resource planning. ▪ Rate cases. ▪ Project financing. ▪ Regulatory compliance and energy plans.
<p>^a The OTC workbook is a spreadsheet tool that was developed from specific results of the PROSYM model.</p>			

▪ *The Clean Air and Climate Protection Software Tool.* As described above, states or localities can use this tool to project an emissions baseline of GHGs and criteria air pollutants into the future, and measure the effects of different policies upon the forecast. <http://www.icleiusa.org/cacp>

States can also project future emissions based on their energy baseline projections. More information about forecasting energy baselines is available in Chapter 2, *Assessing the Potential Energy Impacts of Clean Energy Initiatives*.

4.2.2 STEP 2: QUANTIFY AIR AND GHG EMISSION REDUCTIONS FROM CLEAN ENERGY MEASURES

Once states have developed their baseline emission estimate or business as usual forecast, they can estimate the emissions that are avoided when implementing clean energy measures. Although an emission reduction estimation can be performed independently from a baseline emissions forecast, aligning many of the assumptions in the baseline case and the clean energy measures case is

a desirable exercise. Table 4.2.4 shows that states can use either basic or sophisticated approaches to quantify air emission reductions from clean energy measures.

Basic approaches typically include spreadsheet-based analyses that use emissions factor relationships or other assumptions to estimate reductions. Sophisticated approaches are usually more complex and involve dynamic electricity or energy system representations that predict energy generation responses to policies and calculate the effects on emissions. (For more specific information on these energy-related models, see Chapters 2 and 3.)

Key Considerations for Selecting an Approach for Quantifying Emission Reductions from Clean Energy

As summarized in Table 4.2.4, there are advantages and disadvantages to each approach for quantifying emission reductions. States can use this information as guidance in determining the most appropriate approach for their particular goals. It is important for states to:

- Consider the cost of each potential approach and/or tool and the resources required;
- Determine whether the tools or methods can be used to estimate the pollutants and emissions of interest;¹⁴ and
- Decide between a complex, detailed approach and a simple, transparent screening-level approach based on their pros and cons and relative importance of each.

Basic and sophisticated approaches, including associated uncertainties and limitations, are described in greater detail below.

Basic Approaches to Quantifying Emission Reductions

Basic, screening-level, approaches involve: 1) establishing the operating characteristics of the clean energy resource, also known as its load profile; 2) identifying the marginal generation unit and developing avoided emissions factors; and 3) calculating the total emissions reductions by multiplying the avoided emissions factor by the avoided electricity generation (i.e., as calculated in Chapter 2, *Assessing the Potential Energy Impacts of Clean Energy Initiatives*). These procedures are illustrated in the flowchart in Figure 4.2.1 and described in greater detail below.

Step 2a: Establish Clean Energy Operating Characteristics (Load Profile)

As previously discussed in Chapter 2, *Assessing the Potential Energy Impacts of Clean Energy Initiatives*, the first step when applying a basic modeling approach is to determine the specific ways that the clean energy initiative will affect either demand for electricity or available supply. This involves considering the following issues related to the operating characteristics, or load profile, of the clean energy measures:

- How much energy will the clean energy measure generate or save? (See Chapter 2 for more information)
- When and where will the electricity generation offset occur (e.g., season of year, time of day)? In the case of energy efficiency measure, load impact profiles describe the hourly changes in end use

¹⁴ *The Model Energy Efficiency Program Impact Evaluation Guide, which was developed as part of the National Action Plan for Energy Efficiency (NAPEE), provides further guidance on how to quantify emissions reductions (NAPEE, 2007).*

FIGURE 4.2.1 BASIC APPROACHES FOR QUANTIFYING AIR AND GREENHOUSE GAS REDUCTIONS FROM CLEAN ENERGY

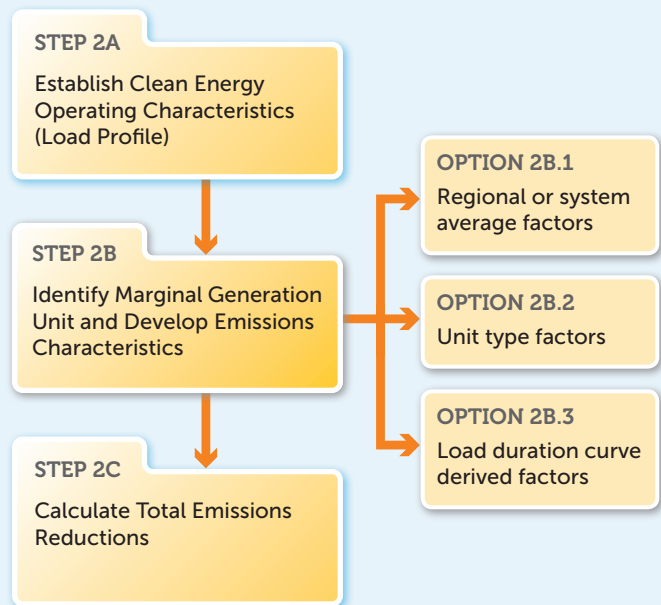

demand resulting from the program or measure. In the case of energy resources, the generation profiles (for wind or PV, for example) are required. (See Chapter 3)

- What, if any, are the emissions characteristics of the clean energy resource (e.g., emissions characteristics of using renewable fuels such as digester gas)?

Step 2b: Identify the Marginal Generation Unit and Develop Emissions Characteristics

Next, identify the marginal generation source and its associated emissions characteristics. The marginal generating source, as described earlier, is the last generating unit to be dispatched in any hour, based on least-cost dispatch (thus it is the most expensive on a variable cost basis). The emissions characteristics of this unit can be expressed as an emissions factor for each pollutant, and are expressed in pounds per MWh. These factors represent the reduction in emissions per pound of energy generation avoided due to energy efficiency or due to clean energy resources supplied to the system.

There are several different approaches that can be used to characterize the marginal generation source and its associated emissions factor. As described in Chapter 3, these include (1) system average, (2) factors based on unit type or other characteristic that correlates

TABLE 4.2.5 COMPARISON OF METHODS TO IDENTIFY MARGINAL UNIT AND ASSOCIATED EMISSIONS FACTOR

Method	Advantages	Disadvantages	When to Use this Method
Regional or system average based on historical year	<ul style="list-style-type: none"> ▪ Computationally simple. ▪ Less labor and data required than for unit type or dispatch curve analysis. 	<ul style="list-style-type: none"> ▪ Insensitive to dispatch process. ▪ Neglects power transfers between areas. ▪ History may not be good indicator of future. 	<ul style="list-style-type: none"> ▪ Rough estimates of clean energy benefits for displacing emissions.
Based on unit type (capacity factor rule)	<ul style="list-style-type: none"> ▪ Simpler and less labor required than dispatch curve analysis. ▪ Considers generation resource characteristics. 	<ul style="list-style-type: none"> ▪ Somewhat insensitive to dispatch process. ▪ Inaccurate for baseload clean energy resources. 	<ul style="list-style-type: none"> ▪ Preliminary planning and evaluation of clean energy resources, especially those that operate during peak times.
Derived from dispatch curve analyses	<ul style="list-style-type: none"> ▪ More sensitive to dispatch process than regional or system average and unit type methods. 	<ul style="list-style-type: none"> ▪ Higher data requirements than regional or system average and unit type methods. 	<ul style="list-style-type: none"> ▪ Planning and regulatory studies.

with likelihood of displacement (e.g., capacity factor), and (3) factors derived from dispatch curve analyses. Information about the advantages, disadvantages, and when to use each method is summarized in Table 4.2.5, *Comparison of Methods to Identify Marginal Unit and Associated Emissions Factor*. Each method is described in more detail below.

- *Regional or system average emissions factors.* This approach typically involves taking an average of the annual emissions of all electricity generating units in a region or system over the total energy output of those units. Data on emission rates averaged by utility, state, and region are available from EPA’s eGRID database. For example, using eGRID, states can locate emissions factors by eGRID subregion, state, or by specific boiler, generator, or plant.

While easy to apply, this method ignores the fact that some units (such as baseload electricity generating units) are extremely unlikely to be displaced by clean energy resources (see text box *What Energy Source is Displaced?*). Baseload units and other units with low variable operating costs (e.g., hydro and renewables) can be excluded from the regional or system average to partially address this shortcoming. Some approaches, therefore, take a fossil-only average.

WHAT ENERGY SOURCE IS DISPLACED?

It is important to note that only a small number of generating plants are affected by a clean energy measure. Power systems are generally dispatched based on economics, with the lowest-cost resource dispatched first and the highest-cost resource dispatched last. The lowest-cost units (known as baseload units) operate at all times and are often fueled by coal. Higher-cost units such as gas- and oil-fired units are brought online during peak use times. These are the units that will be displaced by a clean energy measure. This helps identify where the GHG and air pollutant benefits are likely to occur (See Section 3.1, *How Clean Energy Can Achieve Electric System Benefits*, and Section 3.2, *How States Can Estimate the Electric System Benefits of Clean Energy*, for a more detailed explanation of how generation resources are dispatched).

Other methods for identifying the marginal unit and its emissions factors attempt to recognize that what is on the margin is a function of the time that clean energy load impacts (or energy generation) occurs. The most complete of these time-dependent methods would analyze the impact of changes in load for the 8,760 hours in a year using dispatch models. Basic methods try to approximate this using proxies, including unit type and capacity factor, as described further below.

FIGURE 4.2.2 CAPACITY FACTORS AND UNIT DISPLACEMENT FOR BASELOAD AND LOAD-FOLLOWING PLANTS

In general, baseload plants operate all of the time throughout the year because their operating costs are low and because they are typically not suitable for responding to the many fluctuations in load that occur throughout the day. Thus, their capacity factors are generally very high (e.g., greater than 0.8) and they are unlikely to be affected by short-term fluctuations in load. In contrast, *load-following* plants that can quickly change output have much lower capacity factors (e.g., less than 0.3) and are more likely to be displaced.

The capacity factor of a plant can be used as a proxy for how likely the plant is to be displaced by a clean energy measure. The following graph shows an example of a displacement curve, or a rule for relating the likelihood that a unit's output would be displaced to its capacity factor. Baseload plants on the right side of the curve, such as nuclear units, are assumed to be very unlikely to be displaced; peak load plants on the left, such as combustion turbines, are much more likely to be displaced.

Sample curve for relating displacement to capacity factor

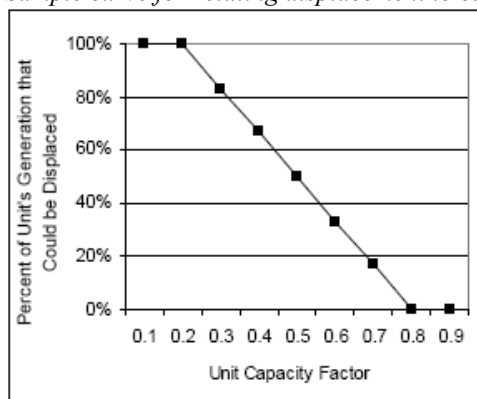

Source: Keith and Biewald, 2005.

- *Displaced unit and emissions factors identification based on type of unit.* As described above, system or regional average emissions factors do not take into account the fact that some electricity generating units are more likely to be displaced by clean energy resources than others. (See Section 3.1, *How Clean Energy Can Achieve Electric System Benefits* and Section 3.2, *How States Can Estimate the Electric System Benefits of Clean Energy*, for a more detailed explanation of how generation resources are dispatched.) The unit type approach for estimating emissions factors takes into account that some classes of units are more likely to be displaced than others by the operation of clean energy measures.

For example, assume coal, nuclear, and hydro plants provide baseload power for an electricity grid. Higher-cost units will operate in a cyclic manner, increasing their output during peak daytime hours. A more efficient new gas-fired unit may be counted on to increase output during the day and decrease output at night, while older, less efficient and more expensive gas and oil units or combustion turbines are only dispatched during the peak output periods. This method can be made more representative by disaggregating the unit types as much as possible (e.g., by unit type, heat rate, and controls).

Estimating emissions factors based on unit type involves the following steps.

1. *Estimate the percentage of total hours each type of unit (e.g., coal-fired steam, oil-fired steam, gas combined-cycle, gas turbine, etc.) is likely to be on the margin* (the highest-cost unit dispatched at any point in time is said to be “on the margin” and is known as the “marginal unit”) and thus to have its output displaced given the load profile of the new clean energy resource. This is discussed further in Chapter 3.
2. *Determine the average emission rate for each unit type* (in pounds of emissions per MWh output). This can be determined based on public data sources such as EPA’s eGRID database or standard unit type emissions factors from EPA AP-42, an available resource for estimated emissions factors.¹⁵
3. *Calculate an emissions-contribution rate for each unit type* by multiplying the unit type average emissions (lbs/MWh) by the fraction of hours that the unit type is likely to be displaced.

Using average emissions to approximate displaced emissions involves significant simplifications of electric system operations. For example, the emission rates for each existing generating unit may vary considerably. Similarly, plants of a certain type may have different operating costs and load-following ca-

¹⁵ Note that AP-42 does not provide GHG emissions factors; for GHGs, use fuel-specific emissions factors from EPA’s Inventory of U.S. Greenhouse Gas Emissions and Sinks. Also note that AP-42 factors are dependent on the air pollution controls that have been installed, and this information would be needed to accurately estimate emission rates. EPA AP-42 is available at <http://www.epa.gov/ttn/chief/ap42/index.html>

pabilities.¹⁶ For example, baseload units operate virtually all the time, load-following units are routinely turned off at night and used most days to meet the higher daytime electricity demand, and peaking units only operate during the highest demand periods (such as hot summer afternoons). Due to the operating characteristics of many types of clean energy projects, the electricity produced or saved is likely to displace electricity from load-following and peaking units in the short term, rather than from baseload units.¹⁷ Generalizations must also be made about the type of generating unit that is on the margin, which may vary considerably across different control areas and time periods.

A limitation of this approach is that it misses important system-level dynamics. For example, reducing emissions of a regulated pollutant may result in shifts in other dispatch decisions in the short and long term. This is particularly true if those emission reductions have a market value (as in cap and trade system). For example, if an energy efficiency option allows for reduced output from a high-emitting oil/gas steam unit during the shoulder period (i.e., that period when demand falls below peak levels but above minimum, base load levels), it may allow increased operation of a coal plant (one not running at full utilization already) at an increased capacity factor. This may reduce system costs all while maintaining emissions at capped levels. In other words, the clean energy option has allowed the operator to reduce emissions compliance costs through dispatch changes. Over the longer term these impacts may include changes in retrofit or build decisions.

As an alternative to estimating the fraction of the time each unit type is on the margin, some analyses estimate the likelihood that a unit type could be displaced using a displacement curve based on capacity factors, shown in Figure 4.2.2, *Capacity Factors and Unit Displacement for Baseload and Load-Following Plants*. The capacity factor is the ratio of how much electricity a plant produces to how much it could produce, running at full capacity, over a given time period. Historical data on, or

estimates of, capacity factors for individual plants are available from EPA's eGRID database.

Displacement rules do not capture some aspects of electric system operations. For example, an extended outage at a baseload unit (for scheduled maintenance or unanticipated repairs) would increase the use of load-following and peaking units, affecting the change in net emissions from the clean energy project. According to a displacement rule, this plant would be more likely to be displaced even though it would rarely if ever be on the margin. Nevertheless, adding this level of detail when estimating emissions factors will generally produce a more credible and accurate estimate of displaced emissions than relying simply on an unweighted system average emissions rate.

- *Emissions Factors Derived from Dispatch Curve Analyses* Load curve analysis is a method for determining tons of emissions avoided by a clean energy resource for a period of time in the past. In general, generating units are dispatched in a predictable order that reflects the cost and operational characteristics of each unit. These plant data can be assembled into a generation “stack,” with lowest marginal cost units on the bottom and highest on the top. A dispatch curve analysis matches each load level with the corresponding marginal supply (or type of marginal supply). Table 4.2.6, *Hypothetical Load for One-Week Period on Margin and Emission Rate* and Figure 4.2.3, *A hypothetical dispatch curve representing 168 hours by generation unit, ranked by load level*, provide a combined example of a dispatch curve that represents 168 hours (a one-week period) during which a hypothetical clean energy resource would be operating.

Table 4.2.6 illustrates this process for a one-week period. There are ten generating units in this hypothetical power system, labeled 1 through 10. Column [3] shows the number of hours that each unit is on the margin, and column [4] shows the unit's SO₂ emission rate. The weighted average SO₂ emission rate for these units is 5.59 lb/MWh.

In many cases, dispatch curves are available from the local power authorities and load balancing authorities (e.g., a regional Independent System Operator (ISO)). If this information is not available, states can attempt to construct their own analysis.

Constructing a dispatch curve requires data on:

¹⁶ “Load-following” refers to those generating resources that are dispatched in addition to baseload generating resources to meet increased electricity demand, such as during daytime hours.

¹⁷ In the longer term, the electricity saved from EE or produced from CE projects not specific to time of day (e.g., CHP, geothermal, not solar) can displace electricity from baseload resources.

TABLE 4.2.6 HYPOTHETICAL LOAD FOR ONE-WEEK PERIOD: HOURS ON MARGIN AND EMISSION RATE

[1]	[2]	[3]	[4]
Unit	Unit name	Hours on margin	SO ₂ emission rate (lb/MWh)
1	Oil Combustion Turbine, Old	5	1.00
2	Gas Combustion Turbine	10	0.00
3	Oil Combustion Turbine, New	9	1.00
4	Gas Steam	21	0.10
5	Oil Steam	40	12.00
6	Gas Combined Cycle, Typical	32	0.01
7	Gas Combined Cycle, New	17	0.01
8	Coal, Typical	34	13.00
9	Coal, New	0	1.00
10	Nuclear	0	0.00

Weighted average, SO₂ emissions (lbs/MWh): 5.59

1. Historical utilization of all generating units in the region of interest;
2. Operating characteristics, including costs and emissions rates of the specific generating units, for each season;
3. Energy transfers between the control areas of the region and outside the region of interest in order to address leakage issues (see text box *Clean Energy and Leakage* earlier in this chapter); and
4. Hourly regional electricity demand (or loads).

Data on operating cost, historical utilization, and generator-specific emission rates can typically be obtained from the EIA (<http://www.eia.doe.gov/cneaf/electricity/page/data.html>), or the local load balancing authority. When generator cost data are not available, capacity factors (from the eGRID database, for example) for traditional generating units can be used to approximate the relative cost of the unit (those with the highest capacity factors are assumed to have the lowest cost). As an exception, variable power resources such as wind and hydropower are assumed to have lower costs than fossil fuel or nuclear units.

If unit-level cost data are available, calculating the weighted average of each unit's emission rate, as shown in Table 4.2.6, is preferable to aggregating plants, especially when there is considerable variation in the emission rates within each unit type.

Operational data (or simplifying assumptions) regarding energy transfers between the control areas of the region and hourly regional loads can be obtained from the ISO or other load balancing authority within the state's region.

Load duration curve analysis is commonly used in planning and regulatory studies. It has the advantage of incorporating elements of how generation is actually dispatched while retaining the simplicity and transparency associated with basic modeling methods. However, this method can become labor-intensive relative to other basic modeling methods for estimating displaced emissions if data for constructing the dispatch curve are not readily available. Another disadvantage is that it is based on the assumption that only one unit will be on the

FIGURE 4.2.3 A HYPOTHETICAL LOAD DURATION/DISPATCH CURVE REPRESENTING 168 HOURS (SHOWN IN HALF-DAY INCREMENTS) BY GENERATION UNIT, RANKED BY LOAD LEVEL

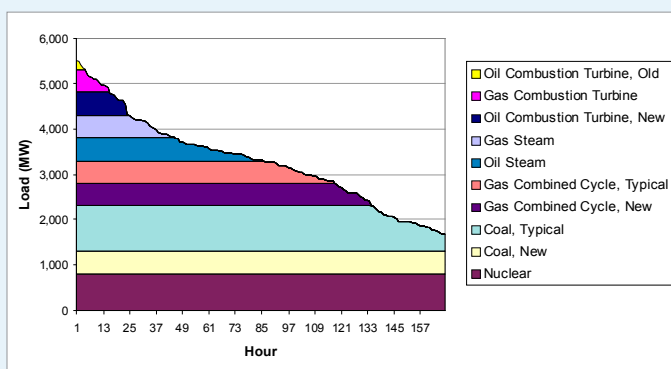

Source: Developed by Synapse Energy, unpublished, 2007.

margin at any given time; this is not generally true in most regions.

- *Summary of Emissions Factor Methods.* In general, for each of the three methods—regional or system emissions factors, factors based on unit type, and factors derived from load duration/dispatch curve analyses—the more detailed the analysis, the more accurate the results, but the more involved it is to make the calculations. The accuracy of the analysis can be improved by calculating separate emissions factors for a number of different time periods during which load and unit operations are known to vary (e.g., peak and off-peak times in the winter and summer months). Ideally, several years of historical emissions and generation data would be used in calculating the average emission rate. For the latter two methods (i.e., emissions factors based on unit types and derived from load duration/dispatch curve analyses), the number of hours that the unit type is on the margin would also be incorporated into the calculation.

Step 2c: Calculate Total Emissions Reductions

Total emission reductions are calculated by applying the emissions factor developed during Step 2b *Identify the Marginal Generation Unit and Develop Emissions Characteristics* to the clean energy resource's level of activity, determined during Step 2a *Establish Clean Energy Operating Characteristics*.

In the final analysis of net emission impacts, it is also important to consider any GHG or criteria air pollution emissions that a clean energy initiative might produce during the production or generation of renewable fuels (e.g., landfill gas, biomass generation). For example, biomass generation releases about the same amount of CO₂ as burning fossil fuels. However, because biomass is a fuel derived from organic matter, including, but not limited to, wood and paper products, agricultural waste, or methane (e.g., from landfills), these materials are part of the natural carbon cycle and therefore do not contribute to global warming. Thus, all biomass CO₂ emissions (including those from renewable methane) are assigned a value of zero because these organic materials would otherwise release CO₂ (or other greenhouse gases) through decomposition.

Tools

Several tools that take a basic modeling approach to estimating emissions reductions are available to states:

USING LOAD DISPATCH CURVE EMISSIONS FACTORS TO ANALYZE THE EMISSIONS IMPACT OF WISCONSIN'S ENERGY EFFICIENCY PROGRAMS

In 2004, the Wisconsin Department of Administration (DOA) released an analysis of the air emission impacts of its Focus on Energy efficiency program. The DOA's evaluation team used a load dispatch curve analysis to estimate which generating plants were "on the margin" during different time periods. Using EPA's CEM data on historical plant operations and emissions reported to EPA, emissions factors were developed for the marginal generating units for different time periods (e.g., peak and off-peak hours during winter and summer) for NO_x, SO₂, and CO₂. These factors were then used to analyze the effects of different energy efficiency programs.

The study found that the marginal units' emission rates tend to be higher during off-peak hours (particularly in winter) than on-peak hours. The study suggests that energy efficiency programs that cut energy consumption in Wisconsin when system demands (and power supply costs) are low may produce the greatest reductions in emissions. For more information on Wisconsin's Focus on Energy program, see Section 4.3.2, Wisconsin - Focus on Energy Program.

Source: Erickson et al., 2004.

- *The Clean Air and Climate Protection Software* (CACPS) tool can be used to estimate emissions reductions in addition to the functions already mentioned above. ICLEI updated and re-released this software in April 2009. Web site: <http://www.icleiusa.org/cacp>
- *The OTC Workbook:* The OTC Workbook is a free tool developed for the Ozone Transport Commission to help local governments prioritize clean energy actions. The Workbook uses a detailed Microsoft Excel spreadsheet format based on electric power plant dispatch and on the energy savings of various measures to determine the air quality benefits of various actions taken in the OTC Region. This tool is simple, quick, and appropriate for scenario analysis. It can calculate predicted emission reductions from energy efficiency, renewables, energy portfolio standards (EPSs), and multi-pollutant proposals. The tool contains two kinds of default emission rate: system average (for assessing EPSs) and marginal (for assessing displacement policies). Users can also input their own data. <http://www.otcair.org>
- *Power Profiler:* The Power Profiler is a Web-based tool that allows users to evaluate the air pollution and GHG impact of their electricity choices. The tool is particularly useful with the advent of electric

ELECTRIC ENERGY EFFICIENCY AND RENEWABLE ENERGY IN NEW ENGLAND: THE OTC WORKBOOK

An analysis conducted by the Regulatory Assistance Project (RAP) explains how energy efficiency and renewable energy have led to many positive effects on the general economy, the environment, and energy security in New England while also quantifying these effects in several new ways. The report assesses the air quality effects of efficiency and renewable investments using the OTC Workbook tool. The analysis finds that there is clear progress in reducing CO₂ emissions from the deployment of energy efficiency and renewable energy. The projections by the OTC Workbook indicate that due to current energy efficiency programs, 22.5 million tons of CO₂ emissions are avoided from 2000–2010.

Source: *The Regulatory Assistance Project*. <http://www.raponline.org/Pubs/RSWS-EEandREinNE.pdf>

customer choice, which allows many electricity customers to choose the source of their power.

<http://www.epa.gov/cleanenergy/powerprofiler.htm>

- *eCalc*: eCalc is an online tool that identifies emission reductions from energy efficiency and renewable energy measures in the Electric Reliability Council of Texas (ERCOT) region. The eCalc tool incorporates both energy modeling (assessing the energy saved by a given measure) and emissions modeling (determining the emissions avoided by those energy savings). The energy modeling capability is extremely robust and detailed, accounting for a wide array of load types with weather normalization. It also includes energy production profiles for wind and solar power. Several states have approached the Energy Systems Laboratory (ESL) at Texas A&M University about developing other versions of eCalc. While the underlying code can be transferred, states will need to customize data such as weather, geography, building standards, emissions regulations, grid characteristics, and other factors. <http://ecalc.tamu.edu/>

Note that many of these spreadsheet-based and other tools rely on models to estimate the underlying emission rates. For example, the OTC Workbook relied on runs of the PROSYM model to establish the emission rates, and eCalc integrates several legacy models depending on the user's desired analysis type. These tools thus have the same underlying concerns as those raised earlier, such as being dependent on key driving assumptions; to the extent that these tools and their inputs are not regularly updated, these key assumptions may no longer be applicable and relevant.

A RESOURCE FOR CALCULATED AVOIDED EMISSIONS: THE MODEL ENERGY EFFICIENCY PROGRAM IMPACT EVALUATION GUIDE

The Model Energy Efficiency Program Impact Evaluation Guide provides guidance on model approaches for calculating energy, demand, and emissions savings resulting from energy efficiency programs. The Guide is provided to assist in the implementation of the National Action Plan for Energy Efficiency's five key policy recommendations and its Vision of achieving all cost-effective energy efficiency by 2025. Chapter 6 of the report presents several methods for calculating both direct onsite avoided emissions and reductions from grid-connected electric generating units. The chapter also discusses considerations for selecting a calculation approach (NAPEE, 2007).

Limitations of Basic Approaches

Basic approaches for quantifying displaced emissions are analytically simple and the data are readily available. However, they involve a less rigorous approach than sophisticated modeling approaches; policy-making and regulatory decisions typically require more rigorous analysis. Basic approaches:

- *Are best suited for estimating potential emission reduction benefits for a relatively short time frame* (e.g., one to three years). Longer-term analyses would require emissions factors that account for impacts on the addition and retirement of energy sources over time and changes in market conditions including environmental requirements.
- *Do not typically account for imported power*, which may be from generating units with very different emissions characteristics than the units within the region or system. These methods also do not account for future changes in electricity import/export patterns, which may change the marginal energy sources during operation of the clean energy measure.
- *Do not account for the myriad factors that influence generating unit dispatch on a local scale*. For example, the emissions impacts of a clean energy resource within a load pocket (an area that is served by local generators when the existing electric system is not able to provide service, typically due to transmission constraints) would affect unit dispatch very differently than measures in an unconstrained region. Higher-cost units must be dispatched in a load pocket because energy cannot be imported from lower-cost units outside of the area.

For these reasons, use of basic approaches is often limited to providing preliminary estimates of emission reductions and reporting approximate program impacts data for annual project reports and program evaluations that do not involve regulatory compliance. Nevertheless, when using basic approaches it is important to remember that the more detailed the representation of the study area, the more precise and reliable the emissions estimates.

Sophisticated Approaches to Quantifying Emissions Benefits

Sophisticated modeling approaches, such as electric dispatch and capacity planning models, can be used to compare baseline energy and emissions forecasts with scenarios based on implementation of clean energy measures. Using sophisticated models to estimate emissions that are displaced as a result of clean energy measures generally results in more accurate estimation of emission impacts than using the basic approaches, but can be more resource-intensive.

Many of the models used to characterize or project changes in electricity supply and demand also provide estimates of the air pollution and GHG impacts associated with clean energy policies. Thus, by comparing clean energy policy scenarios with the BAU case, they facilitate quantification of emissions benefits. Two key types of models used to estimate emissions are electric dispatch models and capacity expansion (also referred to as system planning or planning) models. An electric dispatch model typically answers the question: how will this clean energy measure affect the operations of existing power plants? In other words, the model quantifies the emission reductions that occur in the short term. A capacity expansion model answers the question: how will this clean energy measure affect the composition of the fleet of plants in the future? A capacity model typically takes a long-term view and can estimate emission reductions from changes to the electricity grid, rather than changes in how a set of individual power plants is dispatched.

Some capacity expansion models include dispatch modeling capability, although typically on a more aggregate time scale than dedicated hourly dispatch models. Models that address dispatch and capacity expansion handle both the short and long term. These models are summarized in Table 4.2.7, *Comparison of Sophisticated Modeling Approaches for Quantifying Air and GHG Emission Effects of Clean Energy Initiatives*, and are described in more detail in Chapters 2 and 3).

4.2.3 STEP 3: QUANTIFY AIR QUALITY IMPACTS

When criteria air pollutants are reduced through clean energy measures, as determined under Step 2, the ambient concentrations of both primary and secondary criteria air pollutants are also likely to be reduced. Estimating air quality improvements associated with emission changes is another step in a thorough analysis of the benefits of clean energy initiatives.¹⁸

Modeling ambient air quality impacts can be a complex task, however, requiring sophisticated air quality models and extensive data inputs (e.g., meteorology). Many state and local government air program offices already use rigorous air quality modeling approaches for their State Implementation Plans, as required by the Clean Air Act. These approaches, summarized below, can also be used in evaluating clean energy benefits.

Approaches to Quantifying Air Quality Changes

Sophisticated computer models are often necessary to prepare detailed estimates of the impact of emission changes on ambient air pollution concentrations. There are three broad types of relevant air quality models: dispersion models, photochemical models, and receptor models. All of these models require location-specific information on emissions and source characteristics, although they may represent photochemistry, geographic resolution, and other factors to very different degrees.

- *Dispersion Models.* Dispersion models rely on emissions data, source and site characteristics (e.g., stack height, topography), and meteorological inputs to predict the dispersion of air emissions and the impact on concentrations at selected downwind sites. Dispersion models do not include analysis of the chemical transformations that occur in the atmosphere, and thus cannot assess the impacts of emission changes on secondarily formed PM_{2.5} and ozone. These models can be used for directly emitted particles (such as from diesel engines) and air toxics. EPA currently recommends using either

¹⁸ “Concentrations” versus “emissions.” Ambient—or surrounding—air concentration levels are the key measure of air quality and are based on the monitored amount (e.g., in units of micrograms per cubic meter [µg/m³] or parts per million [ppm]) of a pollutant in the air. Emission levels are based on estimates and monitored measurements of the amount (e.g., in units of tons) of a pollutant released to the air from various sources, such as vehicles and factories. Some emissions travel far from their source to be deposited on distant land and water; others dissipate over time and distance. The health-based standards (National Ambient Air Quality Standards) for criteria pollutants are based on concentration levels. The pollutant concentration to which a person is exposed is just one of the factors that determines if health effects occur—and their severity if they do occur (U.S. EPA, 2009).

TABLE 4.2.7 COMPARISON OF SOPHISTICATED MODELING APPROACHES FOR QUANTIFYING AIR AND GHG EMISSION EFFECTS OF CLEAN ENERGY INITIATIVES

Examples of models	Advantages	Disadvantages	When to Use this Method
Electric Dispatch			
<ul style="list-style-type: none"> ▪ PROSYM ▪ GE MAPS ▪ PROMOD 	<ul style="list-style-type: none"> ▪ Provides very detailed estimations about specific plant and plant-type effects within the electric sector. ▪ Provides highly detailed, geographically specific, hourly data. 	<ul style="list-style-type: none"> ▪ Often lacks transparency. ▪ May require technical experience to apply. ▪ Labor- and time- intensive. ▪ Often high labor and software licensing costs. ▪ Requires establishment of specific operational profile of the clean energy resource. 	<ul style="list-style-type: none"> Often used for evaluating <ul style="list-style-type: none"> ▪ Specific projects in small geographic areas, ▪ Short-term planning (0-5 years), and Regulatory proceedings.
Capacity Expansion or Planning			
<ul style="list-style-type: none"> ▪ NEMS ▪ IPM ▪ ENERGY 2020 ▪ LEAP 	<ul style="list-style-type: none"> ▪ Model selects optimal changes to the resource mix based on energy system infrastructure over the long term (10–30 years). ▪ May capture the complex interactions and feedbacks that occur within the entire energy system. ▪ Provides estimates of emission reductions from changes to generation mix. ▪ May provide plant specific detail and perform dispatch simultaneously (IPM). 	<ul style="list-style-type: none"> ▪ Requires assumptions that have large impact on outputs (e.g., future fuel costs). ▪ May require significant technical experience to apply. ▪ Often lacks transparency of spreadsheet due to complexity. ▪ Labor- and time- intensive. ▪ Often high labor and software licensing costs. 	<ul style="list-style-type: none"> Long-term studies (5–25 years) over large geographical areas such as: <ul style="list-style-type: none"> ▪ State Implementation Plans, ▪ Late-stage resource planning, ▪ Statewide energy plans, and ▪ GHG mitigation Plans.

the AERMOD Modeling System or CALPUFF in SIP revisions analysis for existing sources and for New Source Review. Numerous other dispersion models are available as alternatives or for use in a screening analysis. <http://www.epa.gov/scram001/dispersionindex.htm>

- *Photochemical Models.* The second type of air quality models are photochemical models. Photochemical models include many of the complex physical and chemical processes that occur in the atmosphere as gaseous emissions of different chemicals react and form PM_{2.5} and ozone. These models perform complex computer simulations, and can be applied at a variety of scales from the local to the global level. Photochemical models include EPA’s Community Modeling and Analysis System (CMAQ) and the Comprehensive Air

Quality Model (CAMx). A range of photochemical-type air quality tools are also available for use in assessing control strategies. One example is the Modeled Attainment Test Software (MATS), a PC-based software tool for SIP attainment demonstrations recently developed by EPA. While MATS is not an air quality model per se, it combines CMAQ or CAMx results with monitor data to calculate design values. <http://www.epa.gov/scram001/photochemicalindex.htm>

- *Receptor Models.* Receptor models can identify and quantify the sources of air pollutants at a receptor location. Unlike photochemical and dispersion air quality models, receptor models do not use pollutant emissions, meteorological data, and chemical transformation mechanisms to estimate the contribution of sources to receptor concentrations.

TABLE 4.2.8 AIR QUALITY MODELS CURRENTLY RECOMMENDED BY EPA AND AVAILABLE AT EPA'S SCRAM

Model Acronym	Model Name	Description
Dispersion Models		
CALPUFF	EPA-approved version of the California Puff Model	Single source model with air chemistry for secondary formation. Can analyze secondary formation of ozone and PM2.5.
AERMOD	American Meteorological Society/EPA Regulatory Model	Recommended single source model for direct dispersion modeling (no air chemistry). Replaced Industrial Source Complex (ISC) family of models. Capable of multiple and area source analysis.
Photochemical Models for both Ozone and PM2.5 ("One Atmosphere" models)		
CAMx	Comprehensive Air Quality Model with eXtensions	For ozone, particulate matter, inorganic and organic PM2.5/PM10, mercury and other toxics.
CMAQ	Community Multi-Scale Air Quality model	For ozone, fine particles, toxics, acid deposition, and visibility degradation.
Receptor Models		
CMB	Chemical Mass Balance	The EPA-CMB Version 8.2 uses source profiles and speciated ambient data to quantify source contributions. Contributions are quantified from chemically distinct source types rather than from individual emitters. Sources with similar chemical and physical properties cannot be distinguished from each other by CMB. Many of the source profiles, however, are outdated.
UNMIX	N/A	The EPA UNMIX model "unmixes" the concentrations of chemical species measured in the ambient air to identify the contributing sources.
PMF	Positive Matrix Factorization	A form of factor analysis where the underlying co-variability of many variables (e.g., sample to sample variation in PM species) is described by a smaller set of factors (e.g., PM sources) to which the original variables are related. The structure of PMF permits maximum use of available data and better treatment of missing and below-detection-limit values.

Source: U.S. EPA, 2008c.

Instead, receptor models use the chemical and physical characteristics of gases and particles measured at the source and receptor to identify the presence of, and to quantify source contributions to, receptor concentrations. These models are therefore a natural complement to other air quality models and are used as part of SIPs for identifying sources contributing to air quality problems. <http://www.epa.gov/scram001/receptorindex.htm>

Additional models are available and may be suitable for clean energy benefits analysis. EPA's Support Center for Regulatory Modeling (SCRAM) provides information about the latest versions of models, as well as the status of current recommendations of models for regulatory purposes. Examples of all three of these

types of models are available at SCRAM and are summarized in Table 4.2.8, *Air Quality Models Currently Recommended by EPA and Available at EPA's SCRAM*. <http://www.epa.gov/scram001/aqmindex.htm>

Some states have developed air quality models tailored to their specific region. These models are typically used for air quality policy development purposes, or for air quality forecasting as part of an air quality index alert system. Such local or regional models are suitable for conducting clean energy benefits analysis, and the expertise and data needed by these models are often available within a state. An example of such a tool is the Assessment of Environmental Benefits (AEB) modeling system, described in the text box, which is currently configured for use by the southeastern states.

Recently, approaches have been developed that use the output of photochemical and dispersion models to create screening tools that can be used to quickly evaluate expected responses to emissions changes. These screening tools use information from a series of model simulations in which precursor emissions are reduced by specified amounts (e.g., 10 percent NO_x, 20 percent NO_x, 10 percent VOC, 20 percent VOC, etc.) and the responses by various pollutants (e.g., ozone) are assessed for each simulation to create a pollutant “response surface” for a given area. Once the series of simulations has been completed for a particular region, the users can use the tool to more readily identify the emission reduction options or scenarios that seem most promising relative to their goals. For those scenarios identified by the screening tool as potentially effective, the user can then re-run the full model for the identified scenarios to more accurately evaluate the spatial and temporal aspects of the expected response. Although these screening tools provide a quick way of evaluating the expected response for a variety of scenarios, time and resources are required to develop the initial response surface for each pollutant and each given area of interest.

Examples of air quality screening tools include:

- *EPA Response Surface Modeling (RSM)*: RSM is based on a new approach known as air quality metamodeling, which aggregates numerous pre-specified individual air quality modeling simulations into a multi-dimensional air quality “response surface.” RSM is a metamodel of an air quality model developed using the Community Multi-Scale Air Quality (CMAQ) Modeling system—it is a reduced-form prediction model using statistical correlation structures to approximate model functions through the design of complex multi-dimension experiments. RSM has been successfully tested and evaluated for PM_{2.5} and ozone, respectively (U.S. EPA, 2006a).
- *EPA’s Source-Receptor (S-R) matrix*: The S-R matrix is a reduced-form model based on a regional dispersion model, the Climatological Regional Dispersion Model (CRDM), which provides the relationship between emissions of PM_{2.5} or particle precursors and county-level PM_{2.5} concentrations. The S-R matrix is used to evaluate PM_{2.5} in the Co-Benefits Risk Assessment (COBRA) screening model described later in this chapter (U.S. EPA, 2006b).

ASSESSMENT OF ENVIRONMENTAL BENEFITS MODELING SYSTEM

The Assessment of Environmental Benefits (AEB) modeling system is a web-based tool designed for southeast states to use in estimating the ozone and PM impacts of their energy efficiency and renewable energy projects. This coupled energy-air quality modeling system was developed for use in the SIP development process.

AEB takes user-provided inputs of electricity impacts (efficiency gains or net generation) of location-specific energy efficiency and renewable energy projects and estimates the reduced emissions and air quality improvements that will occur by the avoided conventional electricity generation.

Source: Imhoff, 2006

Key Considerations When Selecting a Method to Assess Air Quality Impacts

Air quality impact analyses enable clean energy policy analysts to quantify current and future changes in the concentration of ambient air pollutants that affect human health. When selecting an air quality model that will comprehensively model either short- or long-term changes in air quality, particularly in urban regions, there are a number of modeling inputs and other factors to consider.

- *The Pollutants for Analysis*. Deciding what pollutants to model is a critical decision when selecting a model. Directly emitted primary pollutants—such as CO, SO₂, direct PM, and many air toxics—require models capable of modeling dispersion and transport (i.e., dispersion models). Secondarily formed pollutants such as O₃ and most PM_{2.5} are formed by chemical reactions occurring in the atmosphere with other pollutants. Secondary pollutants are considerably more difficult to model, requiring a model capable of handling the complex chemical transformations (i.e., photochemical models), as well as short and long-range transport.
- *Sources Affected*. The number and types of sources that result in emissions directly affect the selection of an appropriate air quality model. A model that is appropriate for modeling the impact of a single generating facility with a tall smokestack would be inappropriate for analysis of an initiative that would affect electricity generation throughout the region.
- *Timeframe*. Pollutants are further distinguished by the exposure timeframe that is most relevant to human health impacts—e.g., long-term average

exposure vs. short-term daily or hourly exposure. The impact assessment timeframe can be a key factor in determining appropriate approaches for modeling air quality impacts of clean energy initiative-based emission reductions.

- *Data Availability and Resolution.* Air quality models require large amounts of input data describing a variety of characteristics of the energy-environment system, including emission inventory data, ambient air quality monitoring data, and meteorological data.
- *Geographic Scope.* Selecting the most appropriate analytical tool to model air quality impacts also depends upon the geographical scope of the analysis. Modeling large geographical areas (e.g., a state or a group of states) often requires a different model than when modeling smaller areas (e.g., a city)
- *Meteorological and Topographical Complexities.* When structuring an air quality impact analysis, it is also important to consider regional meteorological and topographical conditions that may affect the transport and chemical reaction of pollutants within a region's atmosphere. Thus, it is important to determine whether air quality models can account for these factors.

4.2.4 STEP 4: QUANTIFY HUMAN HEALTH AND RELATED ECONOMIC EFFECTS OF AIR QUALITY IMPACTS

A central question for many clean energy stakeholders regards the negative human health effects that can be avoided through clean energy-related emission reductions. Estimates of the numbers of avoidable health impacts—from reduced school absences and lost work days to avoided premature deaths—have become standard and powerful techniques to describe the benefits of air-related programs. Quantifying the avoidable health effects associated with clean energy initiatives is an analytical step that typically builds on the estimates of emission reductions and air quality changes. Health research has established strong relationships between air pollution and health effects ranging from fairly mild effects such as respiratory symptoms and missing a day of school or work, to more severe effects such as hospital admissions, heart attacks, onset of chronic heart and lung diseases, and premature death.

Presenting the benefits of clean air initiatives in such tangible terms as reduced cases of health effects can be

a valuable analytical tool to help differentiate between alternative program options, as well as a very effective technique for communicating some of the most important advantages of clean energy. This section describes basic and sophisticated modeling approaches to estimate the human health effects of air quality changes and the monetary value of avoided health effects, a key component of a comprehensive economic benefit-cost analysis.

Methods for Quantifying Human Health Impacts

Estimating the health benefits of air quality improvements can be achieved through basic or sophisticated modeling methods. Basic modeling approaches use results from existing studies, such as regional impact analyses, to extrapolate a rough estimate of the health impacts of a single new facility or clean energy initiative. Sophisticated modeling approaches include screening-level analytical models that can run quickly on a desktop computer, and rigorous and complex computer models that often run on powerful computers and involve a linked series of separate models. Basic and sophisticated approaches are described below.

Basic Modeling Approach

A common basic modeling approach for quantifying the human health effects of a clean energy initiative involves determining the “health benefit value per ton of emission” (also referred to as the benefit per ton, or BPT) to estimate average monetized benefits of an incremental change in pollutant or pollutant precursor. This is a form of “benefits transfer” analysis, where the results from an extensive analysis (e.g., a regional control strategy for all coal-fired power plants within a region) are used to approximate the effects of a smaller project in the same region (e.g., a local clean power initiative). In effect, these metrics represent a composite of the air quality modeling, health impacts estimation, and valuation estimation steps used in more complex models, such as the BenMAP model described below.

EPA has recently developed $PM_{2.5}$ BPT estimates categorized by key $PM_{2.5}$ precursors, source category, and location of the county (Fann, 2008). Applying these estimates simply involves multiplying the emission reduction by the relevant BPT metric.

BPT measures are only first-order approximations of the results that a rigorous analysis might estimate. However, they can serve as pragmatic benefits analysis tools and can be especially useful in assessing the

benefits of small projects where it is impractical to conduct a complex analysis of each alternative.

The role of BPT benefit estimates varies: some states develop these estimates as a useful “rule of thumb” used during screening analysis when formal air quality modeling analyses are impractical due to time and resource constraints, while other states use the estimates as a more formal part of the analysis of proposed projects.

The advantages of BPT estimates include:

- *Simplicity.* Users need only know the anticipated or historical level of emission reductions.
- *Resource efficiency.* Generating benefits estimates requires only a simple spreadsheet.
- *Speed.* Results can be generated very quickly.

Disadvantages of the BPT estimates include:

- *Limited ability to account for spatial heterogeneity.* The BPT estimates are best viewed as the average benefits of emission reductions within a specific spatial scale—either nationwide or within one of a few specific urban areas. In general, the BPT estimates are most appropriate for characterizing the benefits of broad-scale emission reductions.
- *Inflexible.* Users are unable to modify any of the assumptions within the BPT metrics, including the selection of C-R functions, year of population exposure, valuation functions, or air quality modeling.
- *Based on multiple assumptions.* A series of modeling assumptions are embedded within the BPT metrics. Consequently, the greater the divergence between these embedded assumptions and the policy context to which the user applies the BPT metrics, the greater the uncertainty.

A challenge with using BPT measures arises if a clean air project reduces emissions of multiple pollutants simultaneously (e.g., SO₂ and NO_x). In order to reach a more accurate benefit-per-ton estimate, it is important to apportion the benefits among each of the multiple types of emission reductions.

Sophisticated Modeling Approaches

Two sophisticated modeling approaches, which vary in terms of complexity, are used to quantify the hu-

man health impacts of air quality changes: integrated modeling and linked modeling.

Integrated Modeling

Screening-level integrated models include emissions, air quality, health effects, and economic valuation within a single software application that runs quickly on a desktop computer.

An integrated model typically allows the user to enter potential emissions from one or more emission categories, and then apply a series of methods to estimate air quality changes, population exposure, avoided health effects, and the economic values of the quantified benefits. These models are not as rigorous as the linked approach, but can quickly enable a less experienced analyst to prepare a screening-level analysis of many different clean energy alternatives. EPA’s COBRA model is an example of an integrated screening-level model.

Integrated Modeling with COBRA

EPA’s Co-Benefits Risk Assessment (COBRA) model is a computer-based screening model that employs user-specified emission reduction estimates to estimate air quality changes and health effects. It is a stand-alone Windows application that enables users to:

- Approximate the impact of emission changes on ambient air pollution,
- Translate these ambient air pollution changes into related health effect impacts,
- Monetize the value of those health effect impacts, and
- Present the results in various maps and tables.

Using COBRA enables policy analysts to quickly and easily obtain a first-order approximation of the benefits of different policy scenarios and to compare outcomes in terms of air quality (i.e., changes in PM concentrations and pollutants associated with the secondary formation of PM, at the county, state, regional, or national level) or health effects. COBRA is designed to allow users to quickly and easily analyze the health effects of changes in emissions of PM.

The COBRA screening tool is based on the following methodology.

EXAMPLES OF AIR QUALITY HEALTH MODELS

COBRA (a screening-level integrated model)

- Suited to less-experienced modelers.
- Requires air pollution emissions data, which the model converts to air quality changes, as an input.
- Includes health effects of PM.
- Uses EPA-provided default concentration-response (C-R) functions and economic values.

BenMAP (a linked model)

- Suited to experienced modelers, although a new one-step approach improves accessibility and training is available.
- Requires air quality data, which must be estimated exogenously, as an input.
- Includes health effects of PM and ozone.
- Uses EPA-provided C-R functions and economic values, and also allows user-specified functions.

- The model contains detailed emission estimates for the years 2010 and 2015, developed by EPA. Before running a scenario, users must select one of these years as the baseline for their scenario.
- Users can then create their own scenarios by making changes to the emission estimates specified by the chosen baseline. Changes in PM_{2.5}, SO₂, NO_x, NH₃, and VOC emissions can be specified at the county, state, or national level.
- COBRA incorporates user-defined emission changes into a reduced form air quality model, the Source Receptor (S-R) Matrix, to estimate the effects of emission changes on PM concentrations.
- COBRA uses concentration-response (C-R) functions to link the estimated changes in PM concentrations to a number of health endpoints, including premature mortality, chronic bronchitis, and asthma. The C-R functions are based on recent epidemiological studies and are consistent with BenMAP and recent EPA regulatory impact analyses.
- COBRA monetizes the health effects using economic value equations based on those approved in recent EPA rulemakings.

COBRA's use of default C-R function and economic values for health effects removes the burden of selecting these functions and values for users with limited

HEALTH ENDPOINTS INCLUDED IN COBRA

- Mortality.
- Chronic and acute bronchitis.
- Non-fatal heart attacks.
- Respiratory or cardiovascular hospital admissions.
- Upper and lower respiratory symptom episodes.
- Asthma effects, exacerbations, and emergency room visits.
- Shortness of breath, wheeze, and cough (in asthmatics).
- Minor restricted activity days.
- Work loss days

air quality and health modeling experience. The default values in the model are updated to be consistent with current EPA benefits methods. However, this strength in ease of use is also a key limitation because COBRA cannot incorporate more sophisticated air quality and health effect modeling techniques. <http://epa.gov/state-localclimate/resources/cobra.html>

Linked Modeling

Linked models are rigorous methods that combine emission estimation, air quality estimates, population data, baseline health data, and health concentration-response functions in a geographic-based analysis. This approach uses a series of separate models in sequence: a typical sequence of linked models begins with an electricity generation model, followed by an emissions model, an air quality model, a health effects model, and finally an economic valuation model. The results of each major modeling step is used as an input into the next, resulting in a rigorous overall analysis relying on a series of state-of-the-art modeling components.

While such approaches can be data- and resource-intensive, standard methods and models are available. Linked health effects modeling translates estimated changes in air quality into avoidable cases of a wide range of health effects. EPA's methods and models for conducting health analysis have been reviewed by EPA's Science Advisory Board and the National Academy of Science, and are widely used by EPA, as well as state and local governments, as a routine part of developing air quality programs. An example of a linked model for health effects and valuation is EPA's BenMAP.

HOW ARE STATES USING COBRA?

Connecticut worked with EPA and NESCAUM to quantify the economic, air quality, and health benefits of policy options while developing the state's 2005 Climate Change Action Plan. The COBRA model showed that while "the state's (existing) energy efficiency program...was known to achieve a \$3 to \$1 direct return on investment based on electricity savings... an additional \$4 to \$1 payback in terms of reduced health costs and public health benefits was identified as a result of reductions in criteria air pollutants."

Source: Connecticut GSC on Climate Change, 2005.

Linked Modeling with BenMAP

EPA's Benefits Mapping and Analysis Program (BenMAP) is a Windows-based program that enables users to:

- Estimate the health effects for numerous health endpoints associated with changes in ambient O₃ and PM concentrations.
- Monetize the value of health effects.
- Visually inspect results with maps of air pollution, population, incidence rates, incidence rate changes, economic valuations, and other types of data at the county, state, or national level using geographic information systems (GIS).

BenMAP systematically analyzes the health and economic benefits of air pollution control policy scenarios. It is designed to provide flexible and timely analysis, ensure that users can understand the assumptions underlying the analysis, and adequately characterize uncertainty and variability. As a first step, BenMAP estimates impacts to populations from the year 1990 to 2030 according to race, gender, age, and ethnicity. These data are then used to estimate health impacts according to sub-population.

The BenMAP modeling approach is illustrated in Figure 4.2.4 and described below.

- BenMAP applies the damage function approach, a technique used to estimate the health impacts resulting from changes in air pollution. The damage function incorporates air pollution monitoring data, air quality modeling data, Census data, population projections, and baseline health information to relate a change in ambient concentration of a pollutant

FIGURE 4.2.4 BENMAP HEALTH IMPACTS MODELING PROCEDURE

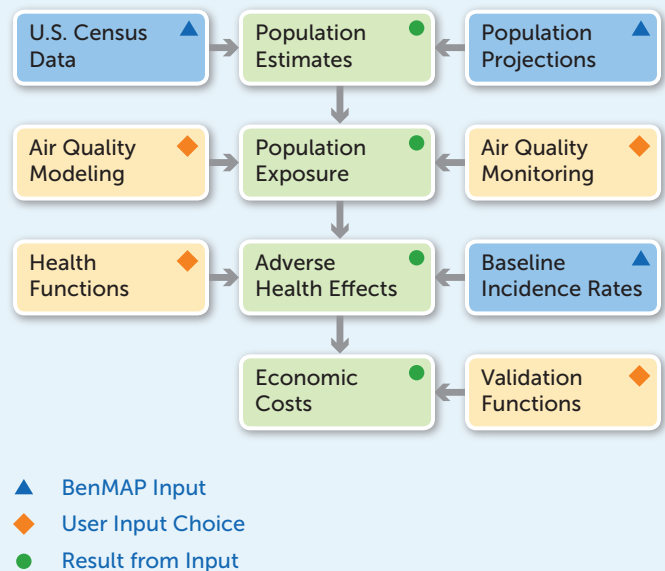

to population exposure, and quantifies the incidence of new or avoided adverse health endpoints.

- Users typically run BenMAP to estimate the health impacts of a policy scenario, specifying both baseline and post-policy air quality levels. BenMAP then estimates the changes in population exposure.
- Air quality information for the baseline and scenario runs need to be generated exogenously, either from monitor-based air quality data, model-based air quality data, or both.¹⁹ BenMAP includes monitoring data for O₃, PM, NO₂, and SO₂ for a number of years.
- BenMAP then calculates the changes in health effect incidence associated with the change in population exposure by using concentration-response functions (C-R) derived from the epidemiological literature and pooling methods specified by the user.²⁰ BenMAP uses the estimate of statistical error associated with each C-R function to generate distributions of

¹⁹ BenMAP accepts air quality output from a variety of models, including Regulatory Model System for Aerosols and Deposition (REMSAD), the Comprehensive Air Quality Model with Extensions (CAMx), the Urban Airshed Monitoring-Variable grid model (UAM-V), the Community Multi-Scale Air Quality Model (CMAQ) and EPA's Response Surface Model (RSM). BenMAP can also accept other model results by changing the default input structure.

²⁰ Pooling is a method of combining multiple health effects estimates to generate a more robust single estimate of health impacts.

incidence estimates, as well as a central point estimate. These distributions are helpful for characterizing the uncertainty associated with this component of the health impact assessment.

- BenMAP also calculates the economic value of the avoided or incurred health effects based on valuation approaches from the published economics literature. The estimated economic value of an avoided health outcome is multiplied by total change in events to determine the health benefits of air quality improvements. As with the C-R functions described above, the valuation functions include estimates of statistical error that BenMAP uses to generate distributions of results (EPA, 2003).

One of BenMAP's strengths is that it includes large databases of C-R functions and economic valuations from which the user can select when performing an analysis. Users can also add new functions. In addition, by using air quality modeling data or actual monitoring data, it provides robust estimates of health impacts with a high degree of spatial resolution (Davidson et al., 2003).

<http://www.epa.gov/air/benmap/>

Key Considerations When Selecting Methods to Estimate Health Effects and Associated Economic Impacts of Clean Energy

The following issues can be considered when selecting a basic or sophisticated modeling approach:

- *Pollutants to be analyzed.* While health modeling for O₃ and PM is the most common approach, analyses are also conducted for SO₂ emissions, CO, Hg, and other air toxics emitted by conventional electricity generation.
- *Selection of health effects.* Even though a long list of health effects analysis is possible, in some circumstances a significantly smaller set may be sufficient. EPA has quantified PM-related health effects including premature mortality in adults and infants, chronic bronchitis, non-fatal heart attacks, hospital admissions for respiratory and cardiovascular diseases, emergency room treatment for asthma, asthma attacks, and various “symptom-days” (including work loss days). Quantified ozone-related health effects include respiratory hospital admissions and emergency room visits, and “symptom-days” (including school absences). Recent health research indicates that O₃ is also associated with premature mortality, which has been included as a new health effect in recent EPA analyses.

HOW BENMAP HAS BEEN USED IN CLEAN ENERGY ANALYSIS

For testimony to the Minnesota Public Utilities Commission about building a new clean energy electricity generating facility, Excelsior Energy compared the air quality and health effects of two proposed 600 MW integrated gasification and combined cycle (IGCC) units with two comparable supercritical pulverized coal (SCPC) units. The analysis used REMSAD to model Hg and PM air quality changes, and BenMAP to estimate and value the PM-related health effects. For the IGCC option, for example, the study found that installing IGCC technology would reduce annual emissions by 2,600 tons of SO₂, 600 tons of NO_x, and 12 pounds of Hg. The largest impacts on PM_{2.5} concentrations occurred within 80 km of the proposed facility, although small PM impacts also occurred hundreds of miles downwind, affecting millions of additional people. The analysis also found that in 2012, the IGCC units would avoid 12 premature deaths nationally, 20 heart attacks (infarctions), eight new cases of chronic bronchitis, and 200,000 work loss days, and quantified estimates of other health effects ranging from hospital admissions to asthma attacks. The annual value of the one year of reduced health effects was estimated to be \$99 million nationally, with \$24 million occurring within Minnesota.

Sources: Excelsior Energy, 2005.

- *Selection of C-R functions for health analysis.* The specific mathematical functions that estimate the changes in health effects from changes in ambient air quality are typically derived from epidemiological research. For most of the health effects selected for an analysis, a variety of alternative C-R functions are available from different sources. It is important to carefully select functions that appropriately reflect the central estimates and the range of diverse results from different published health studies, while striving to avoid double counting and minimizing the omission of important health effects.
- *Time span.* Estimating the health effects for different pollutants requires different time spans. Ozone health effects typically require hourly air quality estimates, but analysis is sometimes limited to the ozone season, or even modeling a one or two week episode during the peak ozone period. Estimating the health effects of PM, on the other hand, typically requires daily air quality estimates throughout the entire year, or estimates of the impact on the annual mean PM level.
- *Geographic scope.* Every health effects estimation procedure operates at some level of geographic resolution. Some health effects models use the county level for the analysis, while others match the level

of the air quality model and use a rectangular grid system. (Hubbell, 2008)

- *Selection of methods for estimating the economic value of avoided health effects.* Estimating the economic value of the avoided cases of each health effect allows stakeholders to more directly compare the economic benefits of a clean energy project with the project's costs. Economic values for each health effect are derived from economic literature, and must be carefully matched to the types of avoided health effects estimated in an analysis.

4.3 CASE STUDIES

4.3.1 TEXAS EMISSIONS REDUCTION PLAN (TERP)

Benefits Assessed in Analysis

- NO_x reductions

Clean Energy Program Description

In 2001, the 77th Texas Legislature established the Texas Emissions Reduction Plan (TERP) with the enactment of Senate Bill 5, which required the Texas Commission on Environmental Quality (TCEQ) to promote EE/RE to meet ambient air quality standards and to develop a methodology for computing emission reductions for State Implementation Plans (Haberl et al., 2004). To improve Texas air quality, TERP adopted the goal of implementing cost-effective EE/RE measures to reduce electric consumption by 5 percent per year for five years, beginning in 2002, using a variety of mandatory programs and voluntary financial incentive programs in non-attainment and affected counties.

These programs included:

- Texas Building Energy Performance Standards for residential and commercial building construction.
- An emissions reduction incentive grants program, which provides grants to offset costs associated with reducing NO_x emissions.
- A new technology research and development program, which provides incentives to support R&D that will reduce pollution in Texas.
- A small business program, which helps small businesses and others participate in the TCEQ's incentive program.

Methods Used

To meet annual reporting requirements, the TCEQ worked with the State Energy Conservation Office (SECO), the Public Utility Commission (PUC), the Energy Systems Laboratory (ESL) and the Electric Reliability Council of Texas (ERCOT) to develop methodologies for quantifying the NO_x emission reductions associated with energy savings from TERP clean energy projects. A key step in that process was to develop uniform accounting procedures to be applied to the energy savings across the different programs. For example, during 2001 and 2002, NO_x emission reduction values could not be integrated across programs because they were reported to the TCEQ by several agencies in disparate units (i.e., lbs-NO_x/year vs. tons-NO_x/OSD), time frames (i.e., annual, average daily), and variations in conversion factors (i.e., lbs-NO_x/MMBtu, g-NO_x/kiloJoule, tons-NO_x/MWh).

Each reporting agency used a unique methodology to estimate energy savings from its programs, all of which were subsequently converted to NO_x emission reductions using eGRID average emissions factors as described below.

- For SECO, Energy Service Companies (ESCOs) reported stipulated energy savings for about 100 projects to SECO. These annual estimates of energy savings were then converted into average daily savings for use in the NO_x emissions calculations for the Ozone-Season-Day (OSD) using eGRID.
- For the PUC's utility-based programs, calculated annual savings for more than 100,000 projects are reported to the PUC using a standard template. These savings are then converted to average daily OSD savings for use in the NO_x emissions calculations for the OSD using eGRID.
- For code-compliant construction programs, the ESL developed simulation models for residential buildings using the DOE-2.1e simulation program. ESL's models were then linked to eGRID to automatically convert energy savings into NO_x emission reductions.
- For green power programs, 15-minute metered data, obtained from ERCOT, and average daily values for the Ozone Season Period were used to represent the OSD electricity and NO_x reductions using eGRID.

Results

- The 2007 annual report on energy savings and emission reductions for energy-code-compliant new residential single, multi-family, and commercial construction reported the following findings (Haberl et al., 2007):
 - The annual energy savings in 2006 amounted to 498,582 megawatt hours (MWh) of electricity and 576,680 million BTUs of natural gas, which led to 361 tons of NO_x reductions in 2006.
 - On a peak summer day—when ozone formation is at its worst—the NO_x reductions in 2006 were calculated to be 2.23 tons per day.
 - Cumulative NO_x reductions, projected to 2013, from energy efficiency savings from code-compliant new residential and commercial construction were determined to be 2,121 tons/year and 10.75 tons/peak-day.

For More Information

- *Energy Efficiency/Renewable Energy Impact in the Texas Emissions Reduction Plan (TERP): Volume 1 – Summary Report*. Prepared for the Texas Commission on Environmental Quality (TCEQ). August 2007, revised December 2007. <http://esl.eslwin.tamu.edu/docs/documents/ESL-TR-07-12-01.pdf>
- Texas Commission on Environmental Quality (TCEQ). <http://www.tceq.state.tx.us/>
- Texas A&M University, Energy Systems Laboratory, Senate Bill 5. <http://esl.eslwin.tamu.edu/senate-bill-5.html>

4.3.2 WISCONSIN – FOCUS ON ENERGY PROGRAM

Benefits Assessed

- Energy savings
- Renewable energy generation
- Reductions of NO_x
- Reductions of CO₂
- Reductions of SO_x
- Reductions of mercury
- Energy bill savings

Clean Energy Program Description

Funded by the Utility Public Benefits fund created by the Wisconsin State Legislature in 1999, the Wisconsin Focus on Energy Program aims to reduce energy use and advance clean energy supplies throughout Wisconsin by:

- Promoting energy efficient practices and equipment in new and existing buildings across the residential, industrial, commercial, agricultural, and government sectors;
- Promoting the installation of renewable energy;
- Educating the public about renewable energy; and
- Providing grants for research on the environmental impacts of electric generation.

Focus on Energy programs include the Wisconsin ENERGY STAR Products (ESP) program, Wisconsin ENERGY STAR Homes (WESH), Home Performance with ENERGY STAR (HPWES), as well as other sector- and renewable-energy-focused programs (DOA, 2005).

Methods Used

To analyze how efficiency programs affect air emissions, the Wisconsin DOA enlisted an independent program evaluation contractor to comprehensively analyze the emission impacts of the state's efficiency programs by quantifying emission reductions for different seasons and hours of the day.

The general approach DOE used to estimate emissions from clean energy programs was to:

- *Develop seasonal and off-peak emissions factors* expressed in pounds of pollutant per MWh or GWh for nitrogen oxides (NO_x), sulfur dioxides (SO_x), carbon dioxide (CO₂), and mercury (Hg) for the regional electricity supply system serving Wisconsin. The DOA used EPA continuous emission monitoring data on historical plant operations and emissions to estimate which generating plants were “on the margin” during different time periods.²¹
- *Multiply the emissions factors by the energy savings from Focus on Energy programs efforts to produce an estimate of the total avoided emissions.*

²¹ EPA Office of Air and Radiation. “Acid Rain/OTC Program Hourly Emissions Data.” <http://www.epa.gov/airmarkets/emissions/raw/index.html>

To determine when the energy savings occurred so that it could apply the corresponding emissions factor (e.g., seasonal, hourly), DOA divided the annual energy savings for each measure into four bins: winter peak, winter off-peak, summer peak, and summer off-peak. DOA made these determinations based on internal evaluations of the operating characteristics of its programs, along with work done by the New Jersey Clean Energy Collaborative and reported in *Protocols to Measure Resource Savings*. http://www.njcleanenergy.com/files/file/Protocols_REVISED_VERSION_1.pdf

- These calculations assume that the energy savings result in reduced generation at the power plants that are operating on the margin during a particular time of day or season. As described earlier in this chapter, the marginal generator is the last generator called upon to meet current demand for electricity, and it can vary over time (within a day and across seasons) as demand changes. Using emissions factors to estimate avoided emissions also assumes that reduced demand is perfectly correlated with reduced emissions.²²

Results

The emission benefits for Focus on Energy’s business and residential programs by peak/season and program

²² This may not always be true. For example, even if demand is reduced in Wisconsin, Wisconsin generators may continue operating as they did before and sell more power out of state.

from July 1, 2001 through September 30, 2003 are summarized in Table 4.3.1.

Based on a more recent study update published in 2006, DOA estimates that from July 1, 2001 through June 30, 2006, its programs saved nearly 1 billion kWhs and nearly 50 million therms in annual energy consumption. This is equivalent to annual energy savings of almost \$80 million for electricity (kWh) and nearly \$50 million in gas savings (therms), and a lifetime dollar value of energy costs saved totaling more than \$660 million for electricity saved and more than \$430 million for gas saved. These programs have displaced annual emissions from power plants and utility customers by:

- 5.8 million pounds of NO_x,
- 2.6 billion pounds of CO₂,
- 11.4 million pounds of SO_x, and
- 46 pounds of mercury.

With stable funding over the next ten years, the state projects that the Focus on Energy program will add nearly \$1 billion in value to Wisconsin’s gross state product (DOA, 2006).

Performing this comprehensive emissions factor derivation improved the accuracy of avoided emission estimates from Focus on Energy efficiency programs and allowed the program to take into account differences

TABLE 4.3.1 EMISSION REDUCTIONS FROM FOCUS ON ENERGY BUSINESS AND RESIDENTIAL PROGRAMS BY PEAK AND SEASON PERIODS (JULY 1, 2001 – SEPTEMBER 30, 2003)

Period	Business Programs				Residential Programs			
	SOX	NOX	CO2*	Hg	SOX	NOX	CO2*	Hg
Pounds								
Summer Off-peak	444,544	216,265	89,429,423	2.1	300,946	146,406	60,541,736	1.4
Summer Peak	473,349	222,184	86,362,026	1.7	311,951	146,426	56,915,134	1.1
Winter Off-peak	715,544	286,218	112,858,634	2.6	597,750	239,100	94,279,589	2.2
Winter Peak	863,768	366,635	125,961,032	2.7	681,608	289,316	99,397,104	2.1
On-site Natural Gas	757	126,146	151,313,733	-	-	-	-	-
Total	2,497,206	1,091,302	414,611,115	9.1	1,892,255	821,248	311,133,562	6.8

Source: Erickson et al., 2004.

across energy efficiency measures in terms of the distribution of energy savings over sectors and periods of time, and develop an optimal portfolio of energy efficiency programs with respect to emission reductions. Using this type of approach, program designers can use the seasonal and peak emissions factors combined with information on load patterns for various types of equipment and businesses to target program efforts towards those areas that would produce the most emissions reductions for a given level of effort (Erickson et al., 2004).

For More Information

- *Estimating Seasonal and Peak Environmental Emission Factors – Final Report*. Prepared by PA Government Services for the Wisconsin DOA. May 2004. http://www.doa.state.wi.us/docs_view2.asp?docid=2404

- *Focus on Energy Public Benefits Evaluation – Semi-annual Summary Report*. Prepared by PA Government Services for the Wisconsin DOA. September 14, 2005. http://www.doa.state.wi.us/docs_view2.asp?docid=5237
- *Focus on Energy Public Benefits Evaluation – Semi-annual Summary Report*. Prepared by PA Government Services for the Wisconsin DOA. September 27, 2006. http://www.focusonenergy.com/files/Document_Management_System/Evaluation/semiannualyearendfy06_evaluationreport.pdf
- *Focus on Energy Program* <http://www.focusonenergy.com/>

Information Resource Description	URL Address
Quantifying Air Emissions Reductions	
Developing a Baseline Emissions Profile	
DOE's State Energy Consumption, Price, and Expenditure Estimates (SEDS) database.	http://www.eia.doe.gov/emeu/states/_seds.html
The ICLEI Cities for Climate Protection program Web site has greenhouse gas emissions inventories and plans developed by many major cities in the United States.	http://www.icleiusa.org/action-center/learn-from-others/action-plans-inventories
State Energy Offices often have energy use data and projections. For example, the New York State Energy Research and Development Authority (NYSERDA) published such data in "Patterns and Trends: New York State Energy Profiles (1993-2007)" (2009).	http://www.nyserda.org/energy_information/patterns%20&%20trends%201993-2007.pdf
Basic Modeling Methods	
Defining operating characteristics/data on load profiles	
The California Database for Energy Efficient Resources (DEER), sponsored by the California Energy Commission and California Public Utilities Commission (CPUC), provides estimates of energy and peak demand savings values, costs, and effective useful life of efficiency measures.	http://www.energy.ca.gov/deer/
NREL's HOMER simplifies the task of evaluating the economic and technical feasibility of design options for remote, stand-alone, and distributed generation applications (both off-grid and on-grid).	http://www.nrel.gov/homer/
National Assessment of Emissions Reduction of Photovoltaic (PV) Power Systems (Analysis Group for Regional Electricity Alternatives, Laboratory for Energy and the Environment, and the Massachusetts Institute of Technology, 2004).	http://www.masstech.org/IS/public_policy/dg/resources/2004_PV-Avoided-Emissions_Main-Report_MIT-Conners-et-al-1.pdf
Some states or regions have technology production profiles in efficiency and renewable energy potential studies, e.g., <i>Energy Efficiency and Renewable Energy Resource Development Potential in New York State: Volume Four</i> contains energy production by costing period for some renewable resources (New York State Energy Research and Development Authority, 2003).	http://www.nyserda.org/Energy_Information/energy_state_plan.asp

Information Resource Description	URL Address
The appendices to the Connecticut Energy Conservation Management Board's <i>Maximum Achievable Potential Study</i> (2004) have detailed data about efficiency measures, including kW in summer and winter (available upon request).	http://www.ctsavesenergy.org/ecmb/documents.php?section=30
NREL's PV Watts calculates location-specific monthly energy production (kWh) from photovoltaic systems.	http://www.nrel.gov/rredc/pvwatts/
Data on emissions rates and capacity factors	
EPA's eGRID database provides information on emissions by individual power plants, generating companies, states, and regions of the power grid.	http://www.epa.gov/egrid
The NEPOOL Marginal Emission Rate Analysis report provides marginal emission rates during four time periods (ozone/one-ozone and peak/off-peak) for NO _x , SO _x , CO ₂ for the NEPOOL region.	http://www.iso-ne.com/genrtion_resrcs/reports/emission/index.html
The Emission Reduction Workbook (OTC Workbook) (Keith, G., D. White, and B. Biewald, 2002) was developed for the Ozone Transport Commission in 2002.	http://www.synapse-energy.com/Downloads/SynapseReport.2002-12.OTC.OTC-Emission-Reduction-Workbook-v-2.1.02-34-Workbook.xls
EPA's Acid Rain data (recently moved to the Clean Air Markets website) provides hourly data on SO ₂ , NO _x , and CO ₂ emissions for Acid Rain and NO _x SIP Call/OTC units since 1997 (since 1995 for coal-fired units).	http://camddataandmaps.epa.gov/gdm/index.cfm?fuseaction=prepackaged.select
<i>Electric Energy Efficiency and Renewable Energy in New England: An Assessment of Existing Policies and Prospects for the Future</i> (the Regulatory Assistance Project and Synapse Energy Economics, 2005) describes an analysis that used the OTC workbook to estimate emissions reductions from efficiency and renewables in New England.	http://www.synapse-energy.com/Downloads/SynapseReport.2005-05.RAP-EPA.Efficiency-and-Renewable-Energy-in-New-England.04-23.pdf
<i>Emerging Tools for Assessing Air Pollutant Emission Reductions from Energy Efficiency and Clean Energy: Phase II Final Report</i> . Global Environment & Technology Foundation, January 31 2005.	http://www.4cleanair.org/EmissionsModelingPhaseIIFinal.pdf
<i>Model Energy Efficiency Program Impact Evaluation Guide</i> provides guidance on model approaches for calculating energy, demand, and emissions savings resulting from energy efficiency programs. The Guide is provided to assist in the implementation of the National Action Plan for Energy Efficiency's five key policy recommendations and its Vision of achieving all cost-effective energy efficiency by 2025.	http://www.epa.gov/cleanrgy/documents/evaluation_guide.pdf
<i>Using Electric System Operating Margins and Build Margins: Quantification of Carbon Emission Reductions Attributable to Grid Connected CDM Projects</i> (Biewald, B. 2005), prepared for the United Nations Framework Convention on Climate Change (UNFCC), analyzed the impact of reductions in electricity demand and renewable generation on CO ₂ emissions.	http://www.synapse-energy.com/Downloads/SynapseReport.2005-09.UNFCCC.Using-Electric-System-Operating-Margins-and-Build-Margins-.05-031.pdf
<i>Methods for Estimating Emissions Avoided by Renewable Energy and Energy Efficiency</i> (Keith, G. and B. Biewald, 2005), prepared for U.S. Environmental Protection Agency, evaluates several methods of estimating displaced emissions without using a dispatch model.	http://www.synapse-energy.com/Downloads/SynapseReport.2005-07.PQA-EPA.Displaced-Emissions-Renewables-and-Efficiency-EPA.04-55.pdf
<i>Modeling Demand Response and Air Emissions in New England</i> (Keith, G., B. Biewald, D. White, and M. Drunisc, 2003), prepared for the U.S. Environmental Protection Agency, presents an analysis of the impact of reductions in electricity demand and renewable generation on air emissions.	http://www.synapse-energy.com/Downloads/SynapseReport.2003-09.US-EPA.NE-DR-and-AE-Modeling.03-01.pdf

Information Resource Description	URL Address
Sophisticated Modeling Methods	
Electric Dispatch Models	
<p>Electric dispatch models that can be used to assess displaced emissions include:</p> <ul style="list-style-type: none"> ▪ GE-MAPS (Multi-Area Production Simulation) ▪ Market Analytics (PROSYM) ▪ PROMOD IV 	<p>GE-MAPS http://www.gepower.com/prod_serv/products/utility_software/en/ge_maps/index.htm</p> <p>Market Analytics http://www.ventyx.com/analytics/market-analytics.asp</p> <p>PROMOD IV http://www.ventyx.com/analytics/promod.asp</p>
Capacity Expansion Models	
<p><i>Energy Portfolio Management: Tools and Practices for State Public Utility Commissions</i> (Steinhurst, W., D. White, A. Roschelle, A. Napoleon, R. Hornby, and B. Biewald, 2006) describes a sample of capacity expansion models.</p>	<p>http://www.synapse-energy.com/Downloads/SynapseReport.2006-07.NARUC.Portfolio-Management-Tools-and-Practices-for-Regulators.05-042.pdf</p>
<p>The Hudson River Foundation financed the <i>Clean Electricity Strategy for the Hudson River Valley</i> (Synapse Energy Economics and Pace Law School Energy Project, 2003). This report explores the air-emissions reductions that would likely result from the implementation of a proposed clean energy plan, consisting of new energy efficiency programs, renewable generation, combined heat and power, and retrofit projects.</p>	<p>http://www.synapse-energy.com/Downloads/SynapseReport.2003-10.Pace.Hudson-River-Clean-Energy-Strategy.02-23.pdf</p>
<p>Capacity expansion models that can be used to assess displaced emissions include:</p> <ul style="list-style-type: none"> ▪ Integrated Planning Model (IPM) (ICF International) ▪ National Energy Modeling System (NEMS) (U.S. DOE) ▪ ENERGY 2020 	<p>Integrated Planning Model (IPM) http://www.icfi.com/Markets/Energy/energy-modeling.asp#2</p> <p>NEMS http://www.eia.doe.gov/oiaf/aeo/overview/index.html</p> <p>ENERGY 2020 http://www.energy2020.com/</p>
Quantifying Air Quality and/or Health Impacts	
SCRAM	http://www.epa.gov/ttn/scram/
REMSAD	http://remsad.saintl.com
CAMx	http://www.camx.com
UAM-V	http://uamv.saintl.com
CMAQ	http://www.epa.gov/AMD/CMAQ/CMAQscienceDoc.html
CALPUFF and AERMOD	http://www.epa.gov/scram001/dispersion_prefrec.htm
COBRA	http://epa.gov/statelocalclimate/resources/cobra.html
BenMAP	http://www.epa.gov/air/benmap/
ASAP	http://www.epa.gov/ttn/ecas/asap.html

Information Resource Description	URL Address
Texas Case Study	
Energy Efficiency/Renewable Energy Impact in the Texas Emissions Reduction Plan (TERP): Volume 1 – Summary Report. Prepared for the Texas Commission on Environmental Quality (TCEQ). August 2007, revised December 2007.	http://esl.eslwin.tamu.edu/docs/documents/ESL-TR-07-12-01.pdf
Texas Commission on Environmental Quality (TCEQ).	http://www.tceq.state.tx.us/
Texas A&M University, Energy Systems Laboratory, Senate Bill 5.	http://esl.eslwin.tamu.edu/senate-bill-5.html
Wisconsin Case Study	
Estimating Seasonal and Peak Environmental Emission Factors – Final Report. Prepared by PA Government Services for the Wisconsin DOA. May 2004.	http://www.doa.state.wi.us/docs_view2.asp?docid=2404
Department of Administration, State of Wisconsin. 2005. Focus on Energy Public Benefits Evaluation – Semiannual Summary Report. Prepared by PA Government Services for the Wisconsin DOA. September.	http://www.doa.state.wi.us/docs_view2.asp?docid=5237
Department of Administration, State of Wisconsin. 2006. Focus on Energy Public Benefits Evaluation – Semiannual Summary Report. Prepared by PA Government Services for the Wisconsin DOA. September.	http://www.focusonenergy.com/files/Document_Management_System/Evaluation/semiannualyearendfy06_evaluationreport.pdf
Focus on Energy Program	http://www.focusonenergy.com/
New Jersey Clean Energy Program. 2007. Protocols to Measure Resource Savings, December.	http://www.njcleanenergy.com/files/file/Protocols_Final_12-20-07_%5B1%5D.pdf
EPA Office of Air and Radiation. "Acid Rain/OTC Program Hourly Emissions Data."	http://camddataandmaps.epa.gov/gdm/index.cfm?fuseaction=prepackaged.select

References	URL Address
Connecticut GSC on Climate Change. 2005. CCCAP. GSC on Climate Change. Connecticut Climate Change Web site, State Action Plan.	http://www.ctclimatechange.com/StateActionPlan.html
Davidson, K., A. Hallberg, D. McCubbin, and B. Hubbell. 2003. Analysis of PM2.5 Using the Environmental Benefits Mapping and Analysis Program (BenMAP). Presented at the 2nd AirNet Annual Conference/NERAM International Colloquium. November.	http://www.informaworld.com/smpp/content~db=all?content=10.1080/15287390600884982 (fee for full text)
Department of Administration, State of Wisconsin. 2005. Focus on Energy Public Benefits Evaluation – Semiannual Summary Report. Prepared by PA Government Services for the Wisconsin DOA. September.	http://www.doa.state.wi.us/docs_view2.asp?docid=5237
Department of Administration, State of Wisconsin. 2006. Focus on Energy Public Benefits Evaluation – Semiannual Summary Report FY06. Prepared by PA Government Services for the Wisconsin DOA. September.	http://www.focusonenergy.com/files/Document_Management_System/Evaluation/semiannualyearendfy06_evaluationreport.pdf
Erickson et al. 2004. Erickson, J., C. Best, D. Sumi, B. Ward, B. Zent, and K. Hausker. Estimating Seasonal and Peak Environmental Emission Factors – Final Report. Prepared by PA Government Services for the Wisconsin DOA. May.	http://www.doa.state.wi.us/docs_view2.asp?docid=2404
Excelsior Energy. 2005. Air Quality and Health Benefits Modeling: Relative Benefits Derived from Operation of the MEP-I/II IGCC Power Station. December.	http://mncoalgasplant.com/15%20Exhibit%20D.pdf
Fann, N, Fulcher, C, Hubbell, B. The Influence of Location, Source, and Emission Type in Estimates of the Human Health Benefits of Reducing a Ton of Air Pollution. Submitted for publication October 2008, Journal of Air Quality, Atmosphere and Health.	http://www.springerlink.com/content/b16jx57531877j31/fulltext.pdf

References	URL Address
Haberl, J., C. Culp, B. Yazdani, D. Gilman, T. Fitzpatrick, S. Muns, M. Verdict, M. Ahmed, Z. Liu, J. Baltazar-Cervantes, C. Montgomery, K. McKelvey, J. Mukhopadhyay, and L. Degelman. 2007. Energy Efficiency/Renewable Energy Impact in the Texas Emissions Reduction Plan (TERP): Volume 1 – Summary Report. Prepared for the Texas Commission on Environmental Quality (TCEQ). August, revised in December.	http://esl.eslwin.tamu.edu/docs/documents/ESL-TR-07-12-01.pdf
Hubbell, Bryan, Fann, N, Levy, J, The Methodological Considerations in Developing Local-scale Health Impact Assessments: Balancing National, Regional, and Local Data. Submitted for publication October 2008, Journal of Air Quality, Atmosphere and Health.	http://www.springerlink.com/content/b16jx57531877j31/fulltext.pdf
Imhoff, B. 2006. Assessment of Environmental Benefits (AEB) Modeling System. Presented at the EPA Air Innovations Conference, Denver. September 6.	http://www.cleanairinfo.com/airinnovations/2006/presentations/Wednesday/Concurrent%201A/AEB%2015%20Air%20Innovations%202006%20Jesse%20Oneal.pdf
IPCC. 2008. Intergovernmental Panel on Climate Change Web Site: Methodology Reports.	http://www.ipcc.ch/publications_and_data/publications_and_data_reports.htm#4
Keith, G. and B. Biewald. 2005. Methods for Estimating Emissions Avoided by Renewable Energy and Energy Efficiency. July 8.	http://www.synapse-energy.com/Downloads/SynapseReport.2005-07.PQA-EPA.Displaced-Emissions-Renewables-and-Efficiency-EPA.04-55.pdf
Metropolitan Washington Council of Governments. 2007. State Implementation Plan: Plan to Improve Air Quality in the Washington, DC-MD-VA Region, May 23. Table 609, p.6-62	http://www.mwcog.org/uploads/pub-documents/9FhcXg20070525084306.pdf
National Action Plan for Energy Efficiency. 2007. Model Energy Efficiency Program Impact Evaluation Guide. Prepared by Steven R. Schiller, Schiller Consulting, Inc. November.	http://www.epa.gov/cleanrgy/documents/evaluation_guide.pdf
NERC. 2009. North American Electric Reliability Corporation Web Site: Key Players - Regions.	http://www.nerc.com/page.php?cid=1 9 119
New Mexico Climate Change Advisory Group. 2006. Climate Change Action Plan. Final Report. December.	http://www.nmclimatechange.us
NYSERDA. 2009. New York State Energy Research and Development Authority, Patterns and Trends: New York State Energy Profiles (1993-2007). December.	http://www.nyserd.org/energy_information/patterns%20&%20trends%201993-2007.pdf
Synapse. 2003. Synapse Energy Economics and Pace Law School Energy Project.	http://www.synapse-energy.com/cgi-bin/synapsePublications.pl?filter_type=Client&filter_option=Pace+Law+School+Energy+Project&advanced=false
Texas Commission on Environmental Quality. 2008. Sources of Air Pollution.	http://www.tceq.state.tx.us/implementation/air/areasource/Sources_of_Air_Pollution.html#top
U.S. Census Bureau. 2008. Population Estimates.	http://www.census.gov/popest/estimates.php
U.S. Department of Commerce. 2008. Bureau of Economic Analysis. Regional Economic Accounts.	http://www.bea.gov/regional/index.htm
U.S. DOE. 2008a. Energy Information Administration. Consumption, Price, and Expenditure Estimates. State Energy Data System (SEDS). November.	http://www.eia.doe.gov/emeu/states/_seds.html
U.S. DOE. 2008b. Energy Information Administration. Environment.	http://www.eia.doe.gov/environment.html
U.S. EPA. 2003. BenMAP User's Manual. Office of Air Quality Planning and Standards.	http://www.epa.gov/air/benmap/

References	URL Address
U.S. EPA. 2004. Guidance On State Implementation Plan (SIP) Credits For Emission Reductions From Electric-Sector Energy Efficiency And Renewable Energy Measures. August.	http://www.epa.gov/ttn/oarpg/t1/memoranda/ereserem_gd.pdf
U.S. EPA, 2006. Clean Energy-Environment Guide to Action: Policies, Best Practices, and Action Steps for States. April.	http://www.epa.gov/statelocalclimate/resources/action-guide.html
U.S. EPA. 2006a. Technical Support Document for the Proposed PM NAAQS Rule: Response Surface Modeling. Office of Air Quality Planning and Standards, Research Triangle Park, NC. February.	http://www.epa.gov/scram001/reports/pmnaaqs_tsd_rsm_all_021606.pdf
U.S. EPA. 2006b. User's Manual for the Co-Benefits Risk Assessment (COBRA) Model. Developed by Abt Associates for the Climate Protection Partnerships Division, Clean Energy-Environment State Partnership Program. Washington, DC.	http://www.epa.gov/statelocalclimate/resources/cobra.html
U.S. EPA, 2007. Technology Transfer Network Clearinghouse for Inventories & Emissions Factors Web Site: Emission Inventory Improvement Program.	http://www.epa.gov/ttn/chief/eiip/techreport
U.S. EPA. 2008. Air Pollution Emissions Overview.	http://www.epa.gov/air/oaqps/emissns.html
U.S. EPA. 2008a. Climate Change – Science Web Site.	http://www.epa.gov/climatechange/science/index.html
U.S. EPA. 2008b. Inventory Of U.S. Greenhouse Gas Emissions And Sinks: 1990-2006. April. USEPA #430-R-08-005	http://www.epa.gov/climatechange/emissions/downloads/08_CR.pdf
U.S. EPA. 2008c. Technology Transfer Network Support Center for Regulatory Atmospheric Modeling: Air Quality Models	http://www.epa.gov/scram001/aqmindex.htm
U.S. EPA. 2008d. What Are the Six Common Air Pollutants?	http://www.epa.gov/air/urbanair/6poll.html
U.S. EPA. 2009. Report on the Environment – Outdoor Air.	http://cfpub.epa.gov/eroe/index.cfm?fuseaction=list.listBySubTopic&lv=list.listByChapter&ch=46&s=341

CHAPTER FIVE

Assessing the Economic Benefits of Clean Energy Initiatives

Given the strong link between economic performance and energy use, it is important for states to account for the macroeconomic effects of potential clean energy policies and programs during the process of selecting and designing these policies. Many studies have shown that when a state makes cost-effective investments in energy efficiency and renewable energy, the state's entire economy will benefit. For example, Wisconsin's Focus on Energy Program was created to manage rising energy costs, promote in-state economic development, protect the environment, and control the state's growing demand for electricity. An analysis conducted by the Wisconsin Department of Administration anticipates that it will meet these objectives while creating more than 60,000 job years, generating more than eight billion dollars in sales for Wisconsin businesses, increasing value added or gross state product by more than five billion dollars, and increasing disposable income for residents by more than four billion dollars between 2002 and 2026 (Wisconsin Department of Administration, 2007; see text box *States Quantifying the Economic Benefits of Clean Energy Policies*). These results demonstrate that positive results from clean energy investments have spread to the broader community.

States can estimate the potential economic benefits of clean energy policies and programs they are considering by projecting potential changes in the flow of goods, services, and income within a regional, state, or local economy. These changes can result in benefits to key macroeconomic indicators, including employment, gross state product, economic output, economic growth, and personal income/earnings. By assessing the benefits of clean energy on these indicators, states can:

- Demonstrate how clean energy can help achieve economic development goals;

DOCUMENT MAP	○	CHAPTER ONE
	○	Introduction
	○	CHAPTER TWO
	○	Potential Energy Impacts of Clean Energy
	○	CHAPTER THREE
	○	Electric System Benefits of Clean Energy
	○	CHAPTER FOUR
○	Air Quality Benefits of Clean Energy	
○	CHAPTER FIVE	
○	Economic Benefits of Clean Energy	
○	APPENDIX A	
○	Catalogue of Clean Energy Case Studies	
○	APPENDIX B	
○	Tools and Models Referenced in Each Chapter	

CHAPTER FIVE CONTENTS

5.1	How Clean Energy Initiatives Create Macroeconomic Benefits.....	134
5.1.1	What are the Direct Effects of Demand-Side Initiatives?.....	135
5.1.2	What are the Direct Effects of Supply-Side Initiatives?.....	136
5.1.3	What are the Indirect and Induced Effects of Clean Energy Initiatives?.....	137
5.2	How Can States Estimate the Macroeconomic Benefits of Clean Energy Initiatives?.....	138
5.2.1	Step 1: Determine the Method of Analysis and Level of Effort.....	138
5.2.2	Step 2: Quantify Expenditures and Savings from the Clean Energy Initiative.....	148
5.2.3	Step 3: Apply the Method to Quantify Macroeconomic Effects.....	153
5.3	Case Studies.....	154
5.3.1	New York: Analyzing Macroeconomic Benefits of the Energy Smart Program.....	154
5.3.2	Illinois: Analyzing the Macroeconomic Benefits of Clean Energy Development.....	156
	Sampling of State Clean Energy Analyses by Type of Analytic Method.....	157
	Information Resources.....	159
	References.....	159

STATES QUANTIFYING THE ECONOMIC BENEFITS OF CLEAN ENERGY POLICIES

Wisconsin's Focus on Energy Program advances cost effective energy efficiency and renewable energy projects in the state through information, training, energy audits, assistance and financial incentives. Its efforts are designed to help Wisconsin residents and businesses manage rising energy costs, promote in-state economic development, protect the environment and control the state's growing demand for electricity and natural gas over the short and long term.

The Wisconsin Department of Administration conducted an evaluation of the economic impacts of the Focus on Energy Program from its inception in 2002 through 2026. The analysis involved:

1. Documentation and extrapolation of the net direct effects of the program, such as program-related spending, energy cost savings and spending on new equipment;
2. Application of a regional economic model (in this case, the REMI model); and
3. Analysis of the implications.

The results indicate that the Focus on Energy Program provides net benefits to the State of Wisconsin. Specifically, the analysis estimates that between 2002 and 2026, the Focus on Energy Program is expected to:

- create more than 60,000 job-years (see the text box *Job Years Versus Jobs*);
- generate sales for Wisconsin businesses of more than eight billion dollars;
- increase value added or gross state product by more than five billion dollars; and
- increase disposable income for residents by more than four billion dollars.

Source: Wisconsin Department of Administration, 2007.

- Build support for their clean energy initiatives among state and local decision-makers; and
- Identify opportunities where meeting today's energy challenges can also serve as an economic development strategy.

This chapter helps states understand the issues and methods for assessing the economic benefits of clean energy options so that they may conduct and manage analyses, review cost and benefit estimates presented to them, and make recommendations about the clean energy options the state should explore or the appropriate evaluation approaches and tools to use.

Section 5.1 explains how clean energy initiatives create direct, indirect, and induced macroeconomic effects

on the economy and can achieve benefits. Section 5.2 presents steps, methods ranging from rule-of-thumb estimates to rigorous dynamic modeling, and issues states can consider using to conduct an analysis of the potential macroeconomic benefits of clean energy programs. Section 5.3 describes a sampling of state macroeconomic analyses as case studies.

5.1 HOW CLEAN ENERGY INITIATIVES CREATE MACROECONOMIC BENEFITS

Clean energy initiatives can result in macroeconomic benefits through *direct*, *indirect*, and *induced* economic effects. As implied by these terms, some of the macroeconomic benefits of clean energy investments accrue to those individuals, businesses, or institutions *directly* involved in the investment, while other benefits arise in related economic sectors and society as a whole via *indirect* and *induced* “ripple” (or “multiplier”) effects.

- The design and scope of the clean energy initiative typically determine the *direct and indirect effects*.
- The structure and composition of the state's economy determine the resulting *indirect and induced effects*.

The direct effects of policies or programs that affect energy demand, such as those that stimulate investments in energy efficient equipment by the commercial or residential sectors, will differ from the direct effects of those that affect the supply of energy, such as renewable portfolio standards. The direct effects of these demand and supply programs are key inputs to macroeconomic analyses. The indirect and induced effects are determined once the direct effects interact with the overall state or regional economy. When exploring the direct, indirect, and induced costs and benefits of clean energy programs, it is useful to consider how the initiative affects other state economic policy objectives, such as distributional equity, and to ensure that it both affects the segments of the economy that were initially targeted and minimizes negative ramifications (e.g., a resulting loss in jobs in another sector, which would have distributional effects).

Direct, indirect, and induced effects are described in greater detail below.

WHAT ARE DIRECT, INDIRECT, AND INDUCED EFFECTS?

Most approaches for quantifying local economic impacts characterize economic impacts based on *direct*, *indirect*, and *induced* effects. The same terms are used in computable general equilibrium and hybrid macroeconomic models

Direct effects are changes in sales, income, or jobs associated with the on-site or immediate effects created by an expenditure or change in final demand; for example, the employment and wages for workers who assemble wind turbines at a manufacturing plant.

Indirect effects are changes in sales, income, or jobs in upstream-linked sectors within the region. These effects result from the changing input needs in directly affected sectors; for example, increased employment and wages for workers who supply materials to the turbine assemblers.

Induced effects are changes in sales, income, or jobs created by changes in household, business, or government spending patterns. These effects occur when the income generated from the direct and indirect effects is re-spent in the local economy; for example, increased employment and wages for workers at the local grocery store because turbine assemblers use their increased wages to buy groceries.

5.1.1 WHAT ARE THE DIRECT EFFECTS OF DEMAND-SIDE INITIATIVES?

Clean energy initiatives that affect the demand side of energy services typically change the energy consumption patterns of business and residential consumers by reducing the quantity of energy required for a given level of production or service. Demand-side initiatives generally aim to increase the use of cost-effective energy efficiency technologies (e.g., including more efficient appliances and air conditioning systems, more efficient lighting devices, more efficient design and construction of new homes and businesses), and advance efficiency improvements in motor systems and other industrial processes. Demand-side initiatives can also directly reduce energy consumption, such as through programs encouraging changing the thermostat during the hours a building is unoccupied or motion-detecting room light switches.

The direct macroeconomic effects of demand-side energy efficiency initiatives arise from the expenditures for goods and services used to implement the initiatives as well as the energy and other cost savings generated by the initiatives. These costs and savings include:

- *Energy cost savings*: dollars saved by businesses and households resulting from reduced energy costs (including electricity, natural gas, and oil cost

Demand-side initiatives usually change the end-use efficiency of energy consumption.

Supply-side initiatives usually change the fuel/generation mix of energy supply resources.

CLEAN ENERGY INITIATIVES EXPAND LOCAL RENEWABLE ENERGY MARKETS AND REDUCE ENERGY COSTS

From 2001–2006, New Jersey’s solar market experienced strong growth and saved solar owners an estimated \$1.1 million annually in total electricity costs, spurred by the Customer On-Site Renewable Energy Program (CORE), which provides rebates for renewable technologies (NJ BPU, 2005).

savings), potentially reduced repair and maintenance costs, deferred equipment replacement costs, and increased property values resulting from the new equipment.

- *Program administrative costs*: dollars spent operating the efficiency initiative, including labor, materials, and paying incentives to participants. It is important to determine how the costs of a program will be funded, such as through a surcharge on consumer electricity bills. If they are funded through general government revenues, it is helpful to consider the impact of diverting funds from other projects.
- *Household and business expenditures*: dollars spent by businesses and households for purchasing and installing more energy-efficient equipment. For policies supported by a surcharge on electric bills, the surcharge is a cost to be included.
- *Sector transfers*: increased flow of dollars to companies that design, manufacture, and install energy-efficient equipment, and reduced flow of dollars to other energy companies—including electric utilities—as demand for electricity and less-efficient capital declines.

These direct costs and savings shift economic activity among participants. For example, they affect the purchasing power of participating consumers, the profitability of participating businesses, and the profitability of conventional power generators. Together, the shifts caused by demand-side initiatives affect income, employment, and overall economic output by:

CLEAN ENERGY INITIATIVES EXPAND LOCAL ENERGY EFFICIENCY MARKETS AND ATTRACT BUSINESS INVESTMENT

For example, from 1999-2005, the number of energy service companies operating in New York State increased from fewer than 10 to over 180 companies, spurred by the New York Energy Smart Program (NYSERDA, 2006b).

- Decreasing residential energy costs, and thereby increasing the disposable income available for non-energy purchases.¹
- Increasing income, employment, and output by reducing the outflow of resources that leave the state when it imports electricity.²
- Increasing income, employment, and output by stimulating the production and sale of energy-efficient equipment by existing businesses within the state.
- Increasing income, employment, and output by decreasing the cost of doing business and improving competitiveness.
- Increasing income, employment, and output by expanding the in-state market for energy efficiency and attracting new businesses and investment.
- Decreasing revenue for utilities due to the reduction in energy sales, unless the state's utility revenue structures allow for program cost recovery or financial incentives for energy efficiency programs.³

5.1.2 WHAT ARE THE DIRECT EFFECTS OF SUPPLY-SIDE INITIATIVES?

Supply-side clean energy policies and programs change the fuel/generation mix of energy resources or otherwise alter the operational characteristics of the energy supply system. Supply-side policy measures generally

¹ An increase in disposable income may be reduced by any program costs imposed upon them. Generally, however, the net effect to, for example, consumers of energy efficiency programs, is positive.

² The magnitude of this impact can be especially significant in states that import large fractions of their energy

³ California, Massachusetts, Minnesota, New York, and Oregon have offered utilities the opportunity to benefit financially from operating effective energy efficiency programs. These financial incentives reward utilities based on the level of energy savings produced and/or cost effectiveness of their energy efficiency programs (SWEET 2002). It is important to consider each individual state's utility revenue structure when exploring the effect of clean energy programs.

JOB YEARS VERSUS JOBS

Studies present employment estimates in terms of jobs and job years, and it is important to understand the difference. For example, a study may predict the creation of 15 job years. This is not the same thing as saying 15 jobs. Fifteen job years can mean one job that lasts for 15 years or it can mean 15 jobs that last for one year. It is important to explain carefully or question what the study is showing for potential job impacts.

In addition, sometimes job results are presented as "net jobs" or even simply "jobs." If an analysis of a clean energy program refers to "net jobs," it means the study factored in any job losses that may have occurred in non-clean energy related sectors due to the policy (e.g., decrease in demand for coal) and presents the impacts on jobs after those losses have been subtracted from any increase. If the results are presented as "jobs," clarification may be needed to determine whether the jobs are gross or net jobs.

support the development of utility-scale renewable energy (RE) and combined heat and power (CHP) applications, and/or clean distributed generation (DG). The direct effects of supply-side initiatives arise from the costs of manufacturing, installing, and operating the RE or CHP equipment supported by the initiative, as well as the energy savings and possible reduced energy supply costs from fuel substitution among entities participating in the supply-side program and their customers. The direct costs and savings of RE/CHP/DG initiatives include:

- *Displacement savings*: dollars saved by utilities from the displacement of traditional generation, including reduced purchases (either local or imports) of fossil fuels and decreased operation and maintenance costs from existing generation resources.
- *Waste heat savings*: dollars saved by utilities or other commercial/industrial businesses using waste heat in CHP applications for both heating and cooling purposes.
- *Program administrative costs*: dollars spent operating the initiative, including labor, materials, and paying incentives to participants. As with demand-side initiatives, it is important to determine how the costs of a program will be funded, such as through a surcharge on consumer electricity bills.
- *Construction costs*: dollars spent to purchase the RE/CHP/DG equipment, installation costs, costs of grid connection, and on-site infrastructure construction costs such as buildings or roads.

WHAT ABOUT OTHER ECONOMIC BENEFITS, SUCH AS AVOIDED CAPACITY INVESTMENT AND LOWER PRICE VOLATILITY?

Clean energy initiatives, whether on the demand side or supply side of the energy system, can create other direct economic benefits to individual energy producers and society as a whole. These benefits—which are economic in character but arise specifically in the energy sector—include increased fuel diversity, transmission reliability, avoided future investment in fossil-fuel generating capacity, reduced wholesale electricity price volatility, reduced fossil-fuel prices, and reduced transmission congestion and losses.

Assessing these benefits requires different methods from those used to assess the benefit mechanisms described in this chapter. These benefits and their assessment are covered in Chapter 3.0, *Assessing the Electric System Benefits of Clean Energy*.

- *Operating costs*: dollars spent to operate and maintain the equipment during its operating lifetime and the cost of production surcharges applied to consumers.

The expenditures and savings associated with supply-side clean energy initiatives shift economic activity among purchases of fuels, business activity in RE/CHP/DG generation, and business activity in existing generation. Together, the shifts caused by supply-side initiatives increase income, employment, and economic output in the state through the:

- Construction and operation of new clean energy-based power facilities.
- Stimulation of economic activity in the state's existing renewable energy industry for both in-state and export markets.
- Expansion of the in-state market for renewable energy services and attraction of new businesses and investment.⁴
- Reduced outflow of dollars for fossil-fuel imports (or increased inflow of dollars for fossil-fuel exports if state is a net fossil-fuel exporter), enabling those dollars to remain within the state.
- Increased application of CHP, in particular, by reducing the cost of doing business and improving overall competitiveness for non-energy companies.

⁴ See also, MTC (2005) and Heavner and Del Chiaro (2003) for additional information on evaluating EE/RE market potential and fostering so-called "clean energy clusters."

WHY QUANTIFY INDIRECT AND INDUCED EFFECTS?

Quantifying the full range—direct, indirect, and induced—of the macroeconomic benefits from clean energy initiatives will maximize the potential value of the policy analysis. For example, the University of Illinois' analysis in 2005 of the proposed Illinois Sustainable Energy Plan estimated that the *direct* outlays and savings for the plan would provide the following benefits to the state of Illinois by 2020:

- A \$7 billion net increase in economic output,
- A \$1.5 billion net increase in personal income, and
- 43,000 net new jobs.

While these benefits are certainly substantial, the study further estimated the following *combined* direct and indirect benefits by 2020:

- An \$18 billion net increase in economic output,
- A \$5.5 billion net increase in personal income, and
- 191,000 net new jobs

In this case, the more robust quantification of macroeconomic benefits, as opposed to simply quantifying direct benefits, led to a substantially different appreciation of the economic significance of the program to the State of Illinois. (Bournakis and Hewings et al., 2005.)

5.1.3 WHAT ARE THE INDIRECT AND INDUCED EFFECTS OF CLEAN ENERGY INITIATIVES?

The distinction between demand-side initiatives and supply-side initiatives is a key factor in understanding the *direct effects* of clean energy initiatives, but this distinction is not necessary to describe *indirect and induced effects*. The indirect and induced effects of clean energy initiatives arise, respectively, from changes in sectors that are economically linked to the directly affected sectors and from changes in the purchases of retail goods and services by the employees of the businesses in which the direct and indirect economic effects occur.

Indirect Effects

Indirect effects result from "upstream" changes in business activity among firms supplying goods and services to industries directly involved in the clean energy initiative. For example, the construction of roads and foundations for a wind farm requires purchases of asphalt and cement from other economic sectors. Each of those other industries must also make purchases to support its own operations, and so forth.

There also can be “downstream” indirect effects, as the regional economy responds to lower energy costs, a more dependable energy supply, and a better economic environment fostering expansion and attracting new business growth opportunities.

In a state-level macroeconomic impact analysis, the fraction of all of the inter-industry purchases that occur within the state comprises the indirect effects. These purchases, in turn, affect income, employment, and economic output in those intermediate sectors.

The ability of the state’s economy to provide the goods and services needed to implement the initiative is a key factor affecting the quantity of in-state indirect effects. In general, a larger, more diverse economy will keep a greater share of the indirect purchases within the state (i.e., the indirect multiplier effects would be larger). For example, a study of the economic benefits of clean energy in New England for the Regulatory Assistance Project noted that “if there were a substantial indigenous renewable generator manufacturing and maintenance industry in New England, then the projected impacts would be larger” (RAP, 2005).

Induced Effects

Induced effects result from the additional purchases of goods and services by households and governments that are affected directly and indirectly by the clean energy initiative as described above (e.g., increased wage income generated from direct and indirect effects is re-spent by individuals; taxes generated by direct and indirect effects are re-deployed by governments). These outlays, in turn, lead to changes in income, employment, and economic output in all economic sectors.

5.2 HOW CAN STATES ESTIMATE THE MACROECONOMIC BENEFITS OF CLEAN ENERGY INITIATIVES?

Assessing the state-level macroeconomic benefits of clean energy initiatives involves measuring changes in the flow of dollars to households and businesses at the state level. Changes in these flows can be estimated as gross impacts (changes without adjustment for what would have occurred anyway) or net impacts (changes over and above what would have occurred anyway). The macroeconomic impacts of clean energy initiatives can also be evaluated for cost-effectiveness. Cost-effectiveness refers to the benefits generated per dollar of program costs.

Quantifying the macroeconomic effects—whether on a gross, net, or cost-effective basis—provides an aggregate measure of the magnitude of the benefits achieved by the initiative. A state can follow several basic steps to analyze the macroeconomic benefits of clean energy initiatives:

1. Determine the method of analysis, the desired level of rigor, and the desired level of detail about geographic and industrial sectors.
2. Quantify the direct costs and savings associated with the initiative.
3. Apply the previously determined method to quantify the macroeconomic impacts created by those costs and savings.

Each of these steps is discussed in more detail below.

5.2.1 STEP 1: DETERMINE THE METHOD OF ANALYSIS AND LEVEL OF EFFORT

Several methods are available to states for quantifying the macroeconomic effects of their clean energy initiatives. They range in complexity from using basic approaches or tools for screening purposes to sophisticated modeling tools for more rigorous dynamic modeling approaches. All of these methods involve predictions, inherent uncertainties, and numerous assumptions. In selecting the most appropriate method, states can consider many different factors, including time constraints, cost, data requirements, internal staff expertise, and overall flexibility and applicability. For example, a state looking to quickly compare many policy options to get an approximate sense of their costs or benefits as part of a stakeholder process would select a different tool than a state tasked by its governor or legislature to determine the sector-specific impacts of a particular policy or strategy. The latter situation would likely require a more rigorous analysis.

Consequently, it is useful for state policy makers to understand the basic differences between the different models and approaches, their strengths and weakness, and their underlying assumptions. The following sections introduce the basic concepts associated with widely accepted screening tools and more advanced models for macroeconomic analysis of clean energy initiatives. Table 5.2.1 describes the advantages and disadvantages of each method and when it is appropriate to use.

TABLE 5.2.1 COMPARISON OF BASIC AND SOPHISTICATED APPROACHES FOR QUANTIFYING MACROECONOMIC EFFECTS OF CLEAN ENERGY INITIATIVES

Type of Method	Sample Tools or Resources	Advantages	Disadvantages	When to Use this Method
<p>Basic Approaches:</p> <ul style="list-style-type: none"> ▪ Rule-of-thumb estimates and ▪ Screening models 	<ul style="list-style-type: none"> ▪ Rule-of-thumb Factors ▪ Job and Economic Development Impact (JEDI) Model ▪ RMI Community Energy Opportunity Finder ▪ Renewable Energy Policy Project Labor Calculator 	<ul style="list-style-type: none"> ▪ May be transparent ▪ Requires minimal input data, time, technical expertise, and labor. ▪ Inexpensive, often free. 	<ul style="list-style-type: none"> ▪ Overly simplified assumptions ▪ Approximate results ▪ May be inflexible. 	<ul style="list-style-type: none"> ▪ When time and resources are short ▪ For high-level, preliminary, analyses ▪ To get quick estimates of employment, output and price changes ▪ When screening a large number of policy options to develop a short list of options for further analysis.
<p>Sophisticated Approaches:</p> <ul style="list-style-type: none"> ▪ Input-Output; ▪ Econometric; ▪ Computable General Equilibrium; and ▪ Hybrid Models 	<ul style="list-style-type: none"> ▪ IMPLAN, ▪ RIMS II ▪ RAND econometric model ▪ BEAR ▪ REMI Policy Insight 	<ul style="list-style-type: none"> ▪ More robust than basic modeling methods. ▪ May be perceived as more credible than basic methods. ▪ Provides detailed results ▪ May model impacts over a long period of time ▪ May account for dynamic interactions within the state/ regional economy. 	<ul style="list-style-type: none"> ▪ May be less transparent than spreadsheet methods. ▪ May require extensive input data, time, technical expertise, and labor commitments. ▪ Often high software licensing costs. ▪ Requires detailed assumptions that can significantly influence results. 	<ul style="list-style-type: none"> ▪ When policy options are well defined ▪ When a high degree of precision and analytic rigor is desired ▪ When sufficient data, time and financial resources are available.

Basic Approaches for Macroeconomic Impact Analysis

At the simpler, less resource-intensive level, screening tools and approaches provide quick, low-cost analyses of policies and require less precise data than needed for a rigorous, advanced analysis. These screening methods provide rough estimates of impacts and give a sense of the direction (i.e., positive or negative) and magnitude of the impacts upon the economy. They provide a useful screening device when many options are under consideration and limited resources are available to conduct advanced analyses. For example, a state considering a lengthy list of climate change mitigation options can use a screening tool to help rank the candidates to create a short list of options that warrant further analyses with more sophisticated tools. Screening approaches, such as rule-of-thumb job factors and tools (e.g., NREL’s JEDI model, the RMI Community

Energy Opportunity Finder, and REPP’s Labor Calculator), are described below.

Rule-of-Thumb Economic Factors

States can apply rules of thumb or generic economic factors to their program results to estimate the economic impacts of clean energy measures in their states. These rules of thumb are typically drawn from more rigorous analyses and can be used when time and resources are limited. However, they provide only rough approximations of clean energy program impacts and so are most applicable for use as screening-level tools for developing preliminary benefit estimates and for prioritizing potential clean energy activities. Table 5.2.2 lists several rules of thumb that states have used to estimate the income, output, and employment impacts of energy efficiency and renewable energy programs.

TABLE 5.2.2 RULES OF THUMB FOR ESTIMATING INCOME, OUTPUT, AND EMPLOYMENT IMPACTS OF CLEAN ENERGY ACTIVITIES

Rule of Thumb	Source
TYPE OF IMPACT: Income/Output	
1 MW of wind generated requires \$1 billion investment in wind generator components.	REPP, 2005 http://www.repp.org/articles/static/1/binaries/Ohio_Manufacturing_Report_2.pdf
\$1 spent on concentrated solar power in California produces \$1.40 of additional GSP.	Stoddard et al., 2006 http://www.nrel.gov/docs/fy06osti/39291.pdf
\$1 spent on energy efficiency in Iowa produces \$1.50 of additional disposable income.	Weisbrod et al., 1995 http://www.edrgroup.com/library/energy-environment/iowa-energy.html
\$1 million in energy savings in Oregon produces \$1.5 million of additional output.	Grover, 2005 http://www.oregon.gov/ENERGY/CONS/docs/EcoNW_Study.pdf
TYPE OF IMPACT: Employment	
\$1 million in energy savings in Oregon produces about \$400,000 in additional wages per year.	Grover, 2005 http://www.oregon.gov/ENERGY/CONS/docs/EcoNW_Study.pdf
\$1 billion investment in wind generator components creates 3,000 full-time equivalent (FTE) jobs.	REPP, 2005 http://www.repp.org/articles/static/1/binaries/Ohio_Manufacturing_Report_2.pdf
\$1 million invested in energy efficiency in Iowa produces 25 job-years.	Weisbrod et al., 1995 http://www.edrgroup.com/library/energy-environment/iowa-energy.html
\$1 million invested in wind in Iowa produces 2.5 job-years.	Weisbrod et al., 1995 http://www.edrgroup.com/library/energy-environment/iowa-energy.html
\$1 million invested in wind or PV produces 5.7 job-years vs. 3.9 job-years for coal power.	Singh and Fehrs, 2001 http://www.repp.org/articles/static/1/binaries/LABOR_FINAL_REV.pdf
1 GWh of electricity saved through energy efficiency programs in New York yields 1.5 sustained jobs.	NYSERDA, 2008 http://www.nyserda.org/pdfs/Combined_Report.pdf
\$1 million of energy efficiency net benefits in Georgia produces 1.6-2.8 jobs.	Jensen and Lounsbury, 2005 http://www.gefa.org/Modules/ShowDocument.aspx?documentid=46

As shown in Table 5.2.2, for example, the Renewable Energy Policy Project (REPP) estimates that every \$1 billion of investment in the components that make up wind generators creates 3,000 full-time equivalent (FTE) jobs. REPP also finds that every megawatt (MW) of wind requires a \$1 billion investment in the generator components (REPP, 2005). If a state has estimated the amount of renewable (wind) electricity that will be generated from its clean energy programs, it can use these factors to determine the amount of jobs that could be created.

The New York State Energy Research and Development Authority (NYSERDA) has developed a similar jobs factor for energy efficiency programs. It estimates that every GWh of electricity saved through energy efficiency programs yields 1.5 sustained jobs.⁵ This factor is derived from a more sophisticated analysis of the macroeconomic impacts of the New York Energy Smart Program through 2007. This analysis estimated that the program had created, on average, 4,700 net jobs each year between 1999 and 2007 while saving about 3,164 GWhs in electricity (NYSERDA, 2008). Dividing the

⁵ By sustained, it means that the job is expected to last 15 years.

number of jobs by the number of GWhs saved through energy efficiency measures yields an average number of net sustained jobs, about 1.5, for each GWh saved. New York uses this number to generate rough estimates of the job impacts of new or expanded energy efficiency-related programs under consideration. For example, when New York announced its 15 by 15 initiative, which set a goal of reducing energy demand by 15 percent or 27,300 GWhs through energy efficiency, NYSEERDA's rule of thumb was used to estimate that the initiative was expected to create about 41,000 jobs in the state.

These rule-of-thumb factors can be handy when time and resources for more rigorous analysis are limited. As shown in Table 5.2.2, however, the range of values is wide. For this reason, it is very important to understand any biases that may be inherent in the rule of thumb before using them. For example, factors can be based on outdated information and would be affected by changes in construction and material costs that have occurred since the factor was derived. Alternatively, factors may not take into consideration that the funds are likely to have come from elsewhere in the economy and may result in negative impacts. For example, the REPP wind-related factor described above may not consider that the \$1 billion investment could have been taken from another sector in the state or the United States as a whole, which may now experience job losses. There is an opportunity cost—the value of the next best alternative forgone—that states should consider when taking resources from one place in the economy and investing them in something different, in this case clean energy. In addition, it is not clear if the 3,000 jobs are net or gross. That is to say, it is not apparent whether the numbers reflect job losses that may occur in other sectors. It also is not obvious whether any additional price increases that the consumer would have to pay for renewable energy have been reflected in the analysis.

For energy efficiency programs, there are similar questions to consider when using a factor. When a state implements a program for energy efficiency through surcharges to rate payers, it is taking money away from the consumers that it would have spent on other goods, possibly creating job losses, and investing them into the energy efficiency program, possibly creating job increases.

Key questions to consider when using a rule-of-thumb estimate include:

- How recent are the construction and material costs used in the factor?

USING JEDI: THE CASE OF WIND POWER IN UTAH COUNTY, UTAH

Wind power has been proposed in Utah as a way to diversify the state's electricity generation. Utah State University used JEDI to inform decision makers about the likely impact of five wind capacity scenarios: 5 MW, 10 MW, 14.7 MW, 20 MW, and 25 MW.

Economic and demographic information was obtained from three sources: (1) the Economic Development Corporation of Utah (EDCU); (2) IMPLAN multipliers for Utah county supplied by NREL; and (3) two local wind developers. These data allowed the study to dictate cost and other inputs specific to their scenarios.

The results of the JEDI analysis indicated promising economic opportunities for wind power in Utah. For example, the proposed Spanish Fork project (14.7 MW) would produce 46 total new jobs, \$1.2 million in wage earnings, and \$4.2 million in economic output during the construction phase of the project (Mongha et al., 2006).

- Does it include the opportunity costs (lost jobs, reduced earnings, spending or GSP) that occur because the money for the clean energy program was taken from elsewhere in the economy?
- If the rule of thumb is related to employment, is the estimate it generates given in jobs or job years (for more information, see text box *Job Years Versus Jobs* earlier in this chapter).
- Does the rule of thumb reflect any price increases consumers may have to pay for the technology or program?

Typically, these are the types of issues addressed in more rigorous analysis but it is important to be aware of any limitations associated with rule-of-thumb factors. Because of these oversimplifications, rule-of-thumb factors are best recognized as screening-level tools that can provide preliminary estimates.

Screening Tools

Job and Economic Development Impact (JEDI) Model for Wind Projects

The U.S. Department of Energy/National Renewable Energy Laboratory (DOE/NREL) developed a spreadsheet-based model, *JEDI*, for estimating the local economic effects of the construction and operation of wind power plants. *JEDI* is designed to be user-friendly and does not require experience with spreadsheets or economic modeling. The model was originally developed with state-level parameters, but it can also be

THE IMPORTANCE OF ACCURATE ENERGY DATA

Accurate and complete state energy data are often missing or incomplete, but are a crucial input to any multiple benefit analysis. States do not always have dynamic energy sector representation and must rely on spreadsheet-level analysis.

used for county and regional analyses. Users enter basic information about the wind plant project (e.g., the project's state, county, or region; the year of construction; the size of the facility), and JEDI calculates the project cost as well as the jobs, income, and economic output that will accrue to the state, county, or region being analyzed. The project cost calculations are based on default expenditure patterns derived from numerous wind resource studies. The user can replace these default values with project-specific information, such as costs and expenditures, financing, taxes, and local share of spending (Goldberg et al., 2004).

JEDI uses input-output analysis to evaluate the direct, indirect, and induced macroeconomic effects from the project expenditures. This type of analysis quantifies relationships among industries in a state, regional, or national economy—i.e., showing how sales of goods and services in one industry lead to purchases or sales of goods and services in other industries. These relationships are depicted as state-specific multipliers that show how the effects of an investment multiply beyond the original transaction. The multipliers are adapted from year 2000 data used in the IMPLAN® Professional model, an input-output modeling tool described below in *Sophisticated Modeling Methods for Macroeconomic Impact Analysis*.

JEDI outputs should not be considered precise values, but rather an indication of the magnitude of potential economic development impacts. Structural characteristics that limit the accuracy of JEDI's results include the following:

- JEDI outputs are presented as aggregate impacts without sector specificity.
- JEDI is a static model and cannot account for future changes in wind power plant costs, changes in industry, or personal consumption patterns in the economy.
- Analyses are specific to wind power plants and therefore represent a gross analysis that does not

reflect net impacts associated with alternative uses of the expenditures.

- Analyses do not account for changes in electricity prices or end-user electricity bills that could result from developing the wind power plant.
- Analyses assume that plant output generates sufficient revenues to accommodate the equity and debt repayment and annual operating expenditures.
- JEDI does not calculate “net jobs” or otherwise reflect the opportunity cost of alternative uses of investment.

http://www.nrel.gov/applying_technologies/market_economic_mt.html

RMI Community Energy Opportunity Finder

The Rocky Mountain Institute (RMI) Community Energy Opportunity Finder is an interactive website tool that provides a preliminary analysis of the potential benefits of implementing energy efficiency or renewable energy in a particular community. This tool has the following characteristics:

- Is designed to perform an initial evaluation of the opportunities for energy efficiency and renewable energy projects in the community.
- Guides the user through the process of collecting energy use data for the local community and then calculates potential energy savings, dollar savings, and job creation that could be achieved through the energy efficiency or renewable energy project.
- Includes many calculations and assumptions based on published literature and substantial experience from dozens of energy experts.
- Can produce a reasonable estimated range of benefits from a small core of energy use data.
- Is limited by using largely default values and other information not necessarily specific to the project being analyzed.

Finder is intended to provide an overall sense of the potential benefits of energy efficiency and renewable energy options in a community, but should not serve in place of a detailed audit of each area or building where energy is used. A variety of cities, utilities, and education programs have used Finder as a screening tool. Examples of Finder applications are available at

USING REPP LABOR CALCULATOR: THE CASE OF NEVADA'S RPS

As part of its 1997 restructuring legislation, the Nevada legislature established an RPS that included a 5% renewable energy requirement in 2003 and a 15% requirement by 2013. The Nevada American Federation of Labor–Congress of Industrial Organizations (AFL-CIO) used the REPP Labor Calculator to estimate the job diversification effects of the RPS (IREC, 2005).

To use the calculator, AFL-CIO had to make a number of assumptions, including assumptions to estimate electricity sales by technology type, which were then used to estimate the installed capacity of each renewable technology.

The results of their analysis showed that, from 2003–2013, the RPS would create 27,229 total, direct full-time-equivalent (FTE) jobs. Of these jobs, 19,138 are estimated to be manufacturing jobs while 8,092 are installation and O&M jobs. These are direct jobs and do not account for any indirect or induced employment effects (AFL-CIO, 2002).

the RMI website. RMI is currently working on revising Finder and developing related web-based tools. <http://www.energyfinder.org/>

REPP Labor Calculator

The Renewable Energy Policy Project (REPP) has developed a tool that calculates the number of direct jobs resulting from state programs, such as an RPS program, that accelerate renewable energy development. The *Labor Calculator* is based on a survey of current industry practices related to manufacturing, installation, and operation and maintenance activities for renewable technologies. The spreadsheet-based format of the calculator provides a transparent framework that lays out all of the labor data and program assumptions.

The user specifies the required installed capacity to meet the renewable energy program requirements (e.g., an RPS), and the calculator determines the number and type of jobs in each renewable activity area by year per installed MW of capacity. The Labor Calculator estimates the total direct labor required to manufacture, install, operate, and service several types of clean energy projects, including wind power, distributed solar PV systems, biomass fuel production for use in biomass co-fired coal plants, and geothermal power plants. REPP is currently developing information to expand the Labor Calculator to include other biomass, geothermal, and solar thermal technologies.

MODELING ENERGY-ECONOMY INTERACTIONS: BOTTOM-UP VS. TOP-DOWN

Bottom-Up and *Top-Down* analyses are the two primary approaches for modeling energy-economy relationships. The major differences between these approaches are the emphases placed on a detailed technologically based representation of the energy system, and the representation of the general economy.

Bottom-up models include a detailed representation of the energy sector in the form of an energy technology matrix, where each technology is represented by engineering cost and performance characteristics. These models are capable of capturing substitution among labor, capital, and fuel inputs among technologies, and other structural changes in the energy sector in response to a given stimulus or policy constraint (Loschel, 2002). These models, however, generally do not assess how energy system changes spill over to other economic sectors and generate macroeconomic or general equilibrium effects. Bottom-up models are also limited in their ability to represent the influences of non-energy markets on cost and performance dynamics of the energy system technologies (Bohringer, 1998; Loschel, 2002).

Top-down models represent the energy sector in a more aggregate way and account for how the energy sector interacts with the rest of the economy. Rather than specifying energy technologies according to their engineering characteristics, top-down models usually represent technologies using aggregate production functions that capture substitution among technologies in response to price changes (i.e., substitution effects). In addition, top-down models usually employ an input-output (I-O) table to simulate supply-demand interactions and the reallocation of all goods and services across the economy. All of the sophisticated modeling methods described below are, fundamentally, top-down models.

The REPP tool is a job calculator, not an economic model. It shows direct gross job effects that could be captured by a state, but does not account for indirect or induced secondary effects. <http://www.repp.org/index.html>

Sophisticated Modeling Methods for Macroeconomic Impact Analysis

The screening tools described above provide relatively simple approximations of the economic feasibility and impact of clean energy initiatives. They are often easy to use, and results can be produced relatively quickly.

However, these tools do not typically provide a sufficient level of sophistication to evaluate substantial investments in clean energy initiatives. Development and implementation of clean energy initiatives at the state level generally require a more comprehensive analysis of the macroeconomic effects of alternative clean

TABLE 5.2.3 OVERVIEW OF SOPHISTICATED MODELING APPROACHES AND TOOLS FOR STATE ECONOMIC ANALYSIS

Example of State Tools	Advantages	Disadvantages	Considerations	When to Use
METHOD: Input-Output (also called multiplier analysis)				
IMPLAN	<ul style="list-style-type: none"> Quantifies the total economic effects of a change in the demand for a given product or service. Can be inexpensive. 	<ul style="list-style-type: none"> Static; multipliers represent only a snapshot of the economy at a given point in time. Generally assumes fixed prices. Typically does not account for substitution effects, supply constraints, and changes in competitiveness or other demographic factors. 	<ul style="list-style-type: none"> Provides rich sectoral detail (NAICS-based). Could be appropriate if the need is to analyze detailed impacts by sector. 	<ul style="list-style-type: none"> Short-term analysis.
METHOD: Econometric Models				
RAND	<ul style="list-style-type: none"> Usually dynamic, can estimate and/or track changes in policy impacts over time. Coefficients are based on historical data and relationships, and statistical methods can be used to assess model credibility. 	<ul style="list-style-type: none"> Historical patterns may not be best indicator or predictor of future relationships. Some econometric models do not allow foresight. 	<ul style="list-style-type: none"> Important to understand if model is myopic or has foresight. 	<ul style="list-style-type: none"> Short- and long-term analysis.
METHOD: Computable General Equilibrium (CGE) Models				
BEAR	<ul style="list-style-type: none"> Account for substitution effects, supply constraints, and price adjustments. 	<ul style="list-style-type: none"> Not widely available at state level. Most CGE models available at state level are static, although a few are dynamic. 	<ul style="list-style-type: none"> Important to examine how the energy sector is treated within any specific CGE model. 	<ul style="list-style-type: none"> Long-term analysis.
METHOD: Hybrid				
REMI Policy Insight	<ul style="list-style-type: none"> Most sophisticated, combining aspects of all of the above. Dynamic, can be used to analyze both short- and long-term impacts. Can be used to model regional interactions. Flexibility of looking at 2-, 3-, or 4-digit NAICS sectors. 	<ul style="list-style-type: none"> Can be expensive, especially if there is a need to analyze impacts on multiple sub-regions (e.g., counties within a state). Can require a fair amount of massaging inputs, especially with energy sector inputs. 	<ul style="list-style-type: none"> Important to examine how energy sector is treated. May need to update default data to account for most recent energy assumptions. 	<ul style="list-style-type: none"> Short- and long-term analysis.

energy initiatives. Several well established models have been developed to quantify the nature and magnitude of the macroeconomic effects of clean energy investments. These approaches include input-output models, econometric models, computable general equilibrium models, and hybrid models. Table 5.2.3 compares key characteristics among these four model types.

Input-Output Models

Input-output (I-O) models, also known as multiplier analysis models, are useful for quantifying macroeconomic impacts because they estimate relationships among industries in a state, regional, or national economy. Policy impacts in I-O models are driven by changes in demand for goods and services.

WHAT IS AN ECONOMIC MULTIPLIER (“RIPPLE EFFECT”)?

An economic multiplier, usually expressed as a ratio, captures how much additional economic activity is generated in each regional industry from a single expenditure (or change in final demand) in another industry.

In I-O models, multipliers estimate the size of sector-specific indirect and induced effects, as well as the economy-wide totals. Multipliers can be derived separately for employment, income, and economic output, and are interpreted differently depending on the form of the multiplier.

In California, for example, a study found that each \$1 invested in new solar generation would result in an additional \$0.50 of economic activity in California (this represents an output multiplier of 1.5). This study also found that 1MW of solar capacity would produce an additional 40 job-years. (Cinnamon and Beach et al., 2005)

At the core of any I-O model is an input-output table, which describes the flow of goods and services from producers to intermediate and final consumers. The I-O table in the most commonly used I-O models in the United States (e.g., IMPLAN, RIMS II) comes from national and regional public data sources such as the Bureau of Economic Analysis’ (BEA’s) national I-O table and regional economic accounts.

The strength of I-O based models is their ability to quantify the total economic effects of a change in the demand for a given product or service. In this context, “total” means the cumulative direct, indirect, and induced effects. The I-O model produces a set of multipliers that describe changes in employment, output, or income in one industry given a demand change in another industry. It is important to note, however, that the multipliers derived from I-O models only represent a snapshot of the economy at a given point in time. Due to their static nature, I-O models generally assume fixed prices and do not account for substitution effects and changes in competitiveness or other demographic factors; thus they are suitable for static or short-term analysis only (RAP, 2005).

In an analysis of the impacts of the Oregon Energy Tax Credits, the modelers determined that the I-O approach was most appropriate for a short-term analysis. With the IMPLAN model, they estimated that the net impacts of the tax credits in Oregon for the year 2006 were an increase in:

- Gross state product of more than \$142 million.
- Jobs by 1,240.

- Tax revenue of nearly \$10 million.

When it came to extrapolating the results into the future, however, they acknowledged that “estimating the long-term impacts taking into account regional changes in energy efficiency and the subsequent impact on economic output requires a much more extensive dynamic modeling exercise (Grover, 2007).” Additional studies that use input-output models are listed in the resource section at the end of this chapter.

Econometric Models

Econometric models are a set of related equations that use mathematical and statistical techniques to analyze economic conditions both in the present and in the future. Econometric models find relationships in the macro-economy and use those relationships to forecast how clean energy initiatives might affect income, employment, output, and other factors. For example, energy demand may be related to the price of fuel, the number of households, and/or the weather but not to individual income levels. These models examine historical data to identify those relationships and make predictions about the future.

Econometric models generally have an aggregate supply component with fixed prices, and an aggregate demand component. The models’ regression coefficients are similar to the multipliers produced by I-O models in the sense that they describe how one component of the economic system changes in response to a change in some other component of the economic system. Most econometric models use a combination of coefficients, some of which are estimated from historical data, and others that are coefficients obtained from other sources.

A key strength of econometric models is that they can estimate and/or track changes in policy impacts over time. Another strength is that consistency between the econometric model structure (developed for analysis) and the underlying economic theory can be evaluated using statistical methods. For example, because historical data are used to generate specific coefficients that reflect the observed relationships between variables, statistical methods can be used to test whether the observed historical data lend support to the (theoretically) hypothesized relationships between variables. This requires the structure of an econometric model to be formulated first based on economic theory and then the model’s coefficients estimated using historical data, rather than developing the structure of the econometric model itself based on the analysis of historical

data (i.e., by developing the structure that best fits the observed data).

Econometric models can be used for both long- and short-term analyses. Because econometric models, in general, rely heavily upon historical data as the pattern for future behavior, the behavior projected is limited because it neglects changes in consumer and business conduct or investments that may occur when future policies and price changes are anticipated. For example, if a carbon standard were proposed today for implementation in five years, one might expect that firms would begin making decisions about investments in energy sources and carbon-efficient technology that would prepare them for when the mandatory provisions take effect. A myopic econometric model might predict that the actors will not alter their strategies until the mandatory provisions provide a “shock,” even though they would be able to anticipate the effect. Unless the econometric model includes a mechanism for responding to anticipated policy changes it may not be able to reflect planning for implementation, thus missing investments in new types of fuels or technologies or planning to avoid last-minute capacity constraints and abandonment of recently purchased equipment. The predicted results of an unanticipated shock may be more negative in the short term than something that is anticipated. For this reason, users will need to be aware of the model limitations and strongly consider choosing a tool with foresight when conducting longer-term studies.

State-level econometric models are often developed by universities, private consulting firms, or nonprofit organizations. For example, RAND Science and Technology, a nonprofit institution, conducted an analysis for the Commonwealth of Massachusetts to retrospectively measure the economic benefit of energy efficiency improvements between 1977 and 1997. By looking at the historical data with their econometric model, they concluded that declines in energy intensity were associated with increases in gross state product and that declines in energy intensity can be an approximation of changes in energy efficiency. They also concluded that government investments in energy efficiency programs may lead to improvements in gross state product. Through statistical and mathematical equations, they could explore the relationship between different key variables, such as energy intensity, gross state product, and government investments, and determine which ones were statistically linked (Bernstein, 2002a). The list at the end of this chapter provides additional examples of state-level clean energy project analyses that have used econometric models.

Computable General Equilibrium Models

Computable general equilibrium (CGE) models use economic data to trace the flow of goods and services throughout an economy and solve for the levels of supply, demand, and price that satisfy the equilibrium constraints across a specified set of markets. Unlike econometric models, CGE models use a framework based on the tenets of microeconomic general equilibrium theory: market clearance and no excess profit. Market clearance refers to the notion that all economic output is fully consumed and that all labor and capital are fully employed. The no excess profit condition assumes that in perfect competition, firms will continue to enter any economic market until excess profits (i.e., profits exceeding a normal rate of return on capital) are diminished to zero. A result of this is that prices will equal the marginal cost of producing a product. When the baseline equilibrium is perturbed, for example, by a clean energy tax incentive, a new market equilibrium is created. Firms will enter and exit existing markets, and the economy will move to a new equilibrium, including adjusting prices and output throughout the economy. In this way, CGE models can be useful for assessing the economy-wide impacts of a clean energy policy.

Many CGE models are calibrated using data from a Social Accounting Matrix (SAM). A SAM is an extension of an I-O table, including additional information such as the distribution of income and the structure of production. Unlike I-O models, CGE models are able to account for substitution effects, supply constraints, and price adjustments in the economy snapshot. That is, CGE models *do not necessarily* use fixed coefficients and fixed prices to determine the relationships between a sector and its upstream and downstream sectors. Like I-O models, most CGE models are static, although some are dynamic.

CGE models are best used for long-term analyses because they may not accurately depict the economic impacts a state experiences on its way to the new equilibrium. The CGE analysis estimates what the economy will resemble in the new steady state. Particularly when compared with a static CGE model, econometric models are typically better at capturing those interim economic changes that will occur between the policy shock and the new equilibrium.

It is important to examine how the energy sector is treated within any specific CGE model. While it may allow for substitution effects, it may not include an option for consumers or firms to switch to renewable energy or

Analyzing Conservation Policies in Connecticut

In 2004, Connecticut analyzed the economic impact of oil and natural gas conservation policies in Connecticut. The state wanted to explore the impacts of fully funding a program between 2005 and 2020 to increase the efficiency of oil and natural gas for residential, commercial, and industrial users.

Connecticut used a hybrid model, the REMI Policy Insight model, for their analysis. REMI is a frequently used proprietary model in the US for analyzing state level policy initiatives. Because the model does not have a detailed energy sector module to fully capture the fuel-switching that would occur within the electricity sector, Connecticut used outputs from an energy analysis using an electricity dispatch model—ICF International’s IPM—to estimate the energy changes used as inputs to Policy Insight. The direct costs included cost increases resulting from a 3% natural gas-use and oil-use surcharge on residential, commercial, and industrial users to pay for the program; the savings to residential, commercial, and industrial users due to reduced consumption of natural gas and oil; the consumption reallocation of other consumer goods due to an increase in personal income; the loss in sales to natural gas and oil firms due to

ECONOMIC GROWTH DUE TO CONSERVATION POLICIES IN CONNECTICUT (CUMULATIVE 2005-2020)

	Oil & Natural Gas	Oil	Natural Gas
Employment (Average Annual Increase)*	2,092	430	1,668
Output (Mil '96\$)	3,094.90	82.80	3,020.64
GSP (Mil '96\$)	2,033.01	266.21	1,773.82
Population	3,604	717	2,894
Real Disposable Personal Income (Mil '96\$)	1,749.42	294.81	1,459.35
State Revenues (Mil '01\$)	382.13	66.75	314.97

* Employment is the average annual increase from the baseline. Employment is not cumulative and is based on output growth. Source: REMI, 2004.

reduced consumption; and the investment in new equipment, construction, research, and other sectors.

These direct effects were used as inputs to the REMI model to determine the indirect, induced, and overall effects of the program. The model was able to break down the results to determine the contribution the oil conservation efforts and the natural gas conservation efforts made to the overall economic impact. For example, as shown in the above table, the overall result of the analysis showed economic benefits to the

state. The natural gas conservation efforts, however, contributed more than the oil programs to the overall benefits of the program. Because the model contains very detailed sector-specific information, the analysts were able to determine that “The disproportionate ratio between the oil and natural gas policies is due to the higher loss in demand for petroleum than for natural gas... the loss in demand of oil is almost 6 times higher than the loss in demand for natural gas” (REMI, 2004).

energy efficiency as a way to meet energy demand. Individual models will handle this differently depending upon the details (e.g., number of sectors) of the model.

CGE models are more readily available at the national level than at the state level, and most CGE models are highly aggregated. Some states, however, have developed and/or used state-specific CGE models to analyze the impacts of clean energy initiatives.⁶ In California, for example, the University of California at Berkeley developed a dynamic CGE model, the Berkeley Energy and Resources (BEAR) model. In addition to the core CGE model, it includes extensive detail about the energy sector and also estimates greenhouse gas emissions. This model has been used to assess the potential

⁶ RTI International developed a CGE model (the *Applied Dynamic Analysis of the Global Economy (ADAGE) Model*) that can be used to explore dynamic effects of many types of energy, environmental, and trade policies, including climate change mitigation policies. For more information on CGE models and their application for macroeconomic impact analysis, see Sue Wing (2004).

impacts of state-level greenhouse gas mitigation policies in California. A recent analysis concluded that nearly 50 percent of California’s 2020 goal of reducing emissions levels to 1990 levels could be achieved using just a handful of options under consideration, while increasing gross state product by 2.4 percent and creating more than 20,000 jobs (Roland-Holst, 2006).

Hybrid Models

Hybrid models incorporate aspects of two or more of the modeling approaches described above, with most models linking an I-O model to an econometric model. Most hybrid models used for energy-related analyses are described as regional economic-forecasting and policy-analysis models. These models are the most sophisticated—and expensive—of the four categories of models.

These models include five analytic elements: (1) output, (2) labor and capital demands, (3) population and

labor supply, (4) wages, prices, and profits, and (5) market shares. The integrated structure of these models allows them to capture everything from economic migration to changes in relative prices and the overall competitiveness of businesses in the economy. These models also include dynamic frameworks that support forecasting of both *what* will happen in response to an initiative and *when* it will happen.

Of the general approaches described in this section, the hybrid modeling approach offers the most flexibility and detail in tailoring an analysis to estimate the effect of a specific clean energy initiative on a state's economy. A user can specify and forecast numerous different model inputs, including: industry output, industry demand, government, investment and/or consumer spending, employment, factor productivity, labor supply, production costs, business taxes and credits, fuel and/or labor costs, wages, housing and consumer prices, and market shares. The results of the complex, dynamic simulations produced by hybrid models can be distilled into net impacts on key economic policy indicators, such as employment, income, and overall economic output. Hybrid models can be effective at estimating both the long- and short-term impacts of policies.

As with other models, it is useful to examine how the energy sector and technological change are treated within a hybrid model. Many states have found that detailed energy-related analyses require energy modeling to be done separately and used as inputs to a hybrid model. This can be a limitation of some hybrid models. In addition, these models can be very complex, time-consuming and expensive to run, and require significant input data.

Hybrid models used for policy analyses include REMI Policy Insight® (see text box *Analyzing Conservation Policies in Connecticut*), those developed by the Regional Economics Applications Laboratory (REAL, developed at the University of Illinois), the Illinois Regional Econometric Input-Output Model (ILREIM), and the Georgia Economic Modeling System (GEMS™, developed at the University of Georgia). A list of additional state-level analyses conducted using hybrid models is provided at the end of this chapter.

Comparison of Models Commonly Used by States to Analyze Clean Energy Initiatives

Table 5.2.4 summarizes key aspects of the four model types—input-output, econometric, CGE and hybrid—that have been frequently used for energy-related

The direct, indirect, and induced macroeconomic benefits arise from the outlays, energy, and dollar savings generated by clean energy initiatives.

It is important for states to understand these outlays and savings because they are key inputs for quantifying changes in employment, income, and output.

policy analyses. State analysts can consider this model information in deciding upon an appropriate model for analyzing the macroeconomic benefits of clean energy initiatives. No one model is perfect for any given analysis case, and the analyst may often choose a given model because it has been used previously for analyses within a state and certain individuals within the state analytic community are more familiar with run specification and interpretation of model outputs.

5.2.2 STEP 2: QUANTIFY EXPENDITURES AND SAVINGS FROM THE CLEAN ENERGY INITIATIVE

The second step in analyzing macroeconomic effects is to quantify the direct expenditures and savings from implementing the clean energy initiative. The expenditures and savings are the primary inputs to the subsequent analysis of macroeconomic effects on income, employment, and output. As described in Sections 5.1.1 and 5.1.2, the specific expenditures and savings that states need to consider in this step are different for demand-side and supply-side initiatives. But generally speaking, these expenditures and savings include estimates of energy savings associated with the initiative and data on expenditures by participating entities and the costs of administering the program.

Key Considerations for Quantifying Expenditures and Savings

States have found it useful to design a strategy to quantify initiative expenditures and savings based on (1) the design and nature of the initiative, (2) the attributes of the state's economy, and (3) the expected behavior of the initiative participants. Several factors contribute to the challenge of developing such a strategy. The analyst can consider the following factors when establishing the necessary data to estimate expenditures and savings (DOA, 2001):

- *Expected energy savings or costs (e.g., oil, natural gas, electricity) to consumers over time.* To perform an economic impact analysis, it is often important

TABLE 5.2.4 COMPARISON OF MODELS FOR ESTIMATING MACROECONOMIC BENEFITS

General Model Category	Input-Output	Econometric	CGE	Hybrid
Example*	IMPLAN	RAND	BEAR	REMI Policy Insight
Model Characteristics				
I-O Component	Yes	Modified I-O	Social Accounting Matrix	Yes
CGE Component	No	Varies	Yes	Yes
Econometric Component	No	Varies	Limited	Yes
Open/Closed Economy	Both	Varies	Yes	Open
Dynamic Modeling Capability	No	Yes	Certain Models	Yes
State and County Level Modeling	Yes	Certain Models	Varies	Yes
Major Data Sources	BEA, BLS, CBP, and Census	Varies	Varies	BEA, BLS, CBP, EIA and Census
Industry Characteristics				
SIC/NAICS Classifications	Yes	Varies	Varies	Yes
Sector Aggregation Options	Yes	Yes	Yes	Yes
Other Features				
Trade Flows	Yes	Certain Models	Most	Yes
Substitution Effects	No	Varies	Yes	Yes
Price and Wage Determination	No	Yes	Yes	Yes
Feedbacks on Competitiveness	No	Yes	Yes	Yes
Migration, Demographic Changes	No	Varies	Varies	Yes
Impacts Measured				
Employment	Yes	Yes	Yes	Yes
Income	Yes	Yes	Yes	Yes
Output	Yes	Yes	Yes	Yes
Value Added	Yes	Yes	Yes	Yes
Proprietary	Yes	Some	Some	Yes
Overall Cost, Complexity, and Capability	Medium	High	High	High
* Models names are included for illustrative purposes only, and do not imply an endorsement by EPA.				

to translate any energy savings into dollars. This monetization can be accomplished by applying projections of prices for different energy types (e.g., coal, oil, gas, electricity) to the profile of expected energy savings. For example, a policy that is funded by a surcharge on electricity bills imposes a cost on consumers but the energy efficiency

investments will result in energy cost savings. Both will affect the economy. For more information on calculating energy savings, see Chapter 2, *Assessing the Potential Energy Impacts of Clean Energy Initiatives*.

- *Expected clean energy investment and realization rates in the short and long terms.* This factor is particularly important with regard to energy efficiency initiatives. In assessing the expected change in energy use from the proposed initiative, it is helpful to break down the most likely level of energy savings realization by participant group and/or equipment type. This “intention” information may be collected via a survey of potential participants or estimated using program analyses.⁷ For example, a program might expect to achieve 30 percent penetration of a new technology in the residential sector in the short run, but 60 percent in the longer term. Both short- and long-term realization rates can significantly affect the overall magnitude and time profile of program effects. Therefore, states may find it useful to analyze the potential impacts of a program under different realization scenarios and then focus program efforts on achieving the optimal level of adoption over time.
- *The proportion of investment from individual participants versus program funding.* The energy savings from a program are partially reduced by any up-front outlays by program participants. It is important to account for participants’ expected outlays because these outlays will affect the economic performance of the total program (including outlays and savings for participants). Participants’ expenditures (and expected downstream savings) will also influence program participation. It is also an important factor to account for the amount and source of program funding. Program expenditures can affect the state economy; however, the nature and extent of those effects will depend on where the program funds come from (e.g., a system benefits charge applied to electricity bills) and the distribution of funds across different economic sectors. For example, a state might implement an energy-efficient water heater rebate program that is funded through a surcharge on all electricity bills. A portion of the amount paid will be returned to some consumers in the form of rebates. These rebates will cover some of the purchase cost of the new water heater. In this instance, the investment in the new water heaters is paid by program participants directly and electricity consumers through the surcharge.

- *The amount of initiative-related activity expected to occur locally.* For any type of spending/sales that originates within a state, part of the dollars will flow to businesses located in the state and part will flow to businesses outside of the state. Accounting for where those dollars flow is important because, to the extent that program-related flows replace flows that would have otherwise left the state, there is potential for in-state net economic gain. This effect is known as “import substitution,” and is measured by factors called “regional purchase coefficients” (RPC). All four of the economic models shown in Table 5.2.4 use RPCs to account for this effect.⁸
- *The expected useful life of the clean energy investment.* Any estimation of program expenditures and savings requires information on the useful life of the products or services provided by the program. The costs and savings associated with program investments can be amortized over the expected useful life of the product or service. For example, a state program might promote the purchase of energy-efficient appliances but these appliances do not last indefinitely. It is important to consider life of the products when calculating potential long-term benefits of a program. If one expects the program to continue beyond the useful life of the initial investments, the analysis can also account for renewed investments when estimating the long-term character of program expenditures and savings.
- *The expected persistence of energy savings over time.* Estimation of expenditures and savings requires assumptions regarding the persistence of the energy savings over time. This may be, for example, an assumed annual loss of energy savings attributable to factors such as deterioration of equipment performance, removal of equipment, business closures, or other factors relevant to the persistence of demand- or supply-side energy saving effects. Note that the useful life of a clean energy investment is a key determinant in the ultimate long-term persistence of savings, but that the persistence of savings can also vary over time during the useful life.
- *The expected economic benefits associated with energy system, environmental, or public health benefits.* Potential energy system benefits, such as fuel

⁷ As a corollary, in estimating the energy savings to be achieved by a program, it is also important to account for, and net out, the baseline energy savings that would have occurred without the program.

⁸ RPCs can be estimated for specific products or services based on analysis of, for example, the extent to which a state has a disproportionately large or small base of manufacturers providing the relevant types of energy-saving equipment (DOA 2001). Alternatively, many economic models contain default RPC values.

cost savings and avoided capacity or transmission and distribution costs to the electricity generators and/or distributors, are economic benefits that can be estimated and included in an economic analysis in addition to the energy cost savings to consumers above. (For more information about energy system benefits, see Chapter 3, *Assessing the Electric System Benefits of Clean Energy*.) Likewise, environmental benefits such as reductions in criteria air pollutants can reduce the costs of complying with air quality standards and yield human health benefits such as avoided deaths, illnesses, and hospitalizations, and reductions in lost work days due to illnesses. As described in Chapter 4, an economic value can be estimated for many of these benefits, and they can be included in the economic analysis to ensure adequate representation of the overall benefits in the analysis.

In addition to these considerations, the appropriate method and data for quantifying costs and savings are influenced by the macroeconomic analysis method selected in Step 1 and its associated data requirements.

Methods for Quantifying Direct Expenditures and Savings

A wide range of methods can be used to quantify the direct expenditures and savings of a potential clean energy initiative (that go beyond those covered in this *Resource*), and states often develop a customized approach based on their specific needs and resources. For a prospective analysis of expenditures and savings, most methods involve projections using some modeling capability. Models available for prospective analyses range from relatively simple, spreadsheet-based models like Excelergy (see California example below) to more rigorous and data-intensive models such as the Long Term Industrial Energy Forecasting model (LIEF) and the Integrated Planning Model (IPM®), an electric power sector model (see Georgia and SWEEP examples). If an initiative has already been implemented, the modeling approach can be supplemented with actual expenditure and/or savings data from the program. In such instances, analysts can use already-collected program data on expenditures and savings as inputs to a retrospective analysis of macroeconomic effects, or as inputs to a prospective analysis of future expenditures and savings (or both, as is done in Massachusetts - described below). Including these actual expenditures and savings likely will require some type of “mapping”

to defined economic sectors (e.g., by NAICS or SIC) before being entered into the models.

Examples of the methods that states have used to quantify expenditures and savings in prior analyses of clean energy initiatives are presented below. The first three examples (California, Georgia, and the Southwest) describe instances where the analysis was prospective and used modeling techniques to estimate the expenditures and savings of potential clean energy investments. The last example (Massachusetts) shows how a state might use actual clean energy initiative expenditures and savings to (1) estimate macroeconomic effects retrospectively and (2) project the future expenditures and savings from an initiative [also see Grover (2005), NYSERDA (2006b), and Sumi et al. (2003) for examples of using actual initiative data on expenditures and savings to estimate macroeconomic effects retrospectively]. More information on these studies can be found in the resource section at the end of the chapter.

California Concentrated Solar Power

A study of concentrated solar power (CSP) in California evaluated the potential benefits—in terms of direct and indirect effects on employment, earnings, and GSP—of the deployment of 2,100–4,000 MW of CSP from 2008–2020 (Stoddard et al., 2006). The outlay and savings data needed to quantify the direct and indirect effects of the project on employment, earnings, and GSP included the dollars spent by the project in California on materials, equipment, and wages.

The California study used data from the Excelergy Model, developed and maintained by NREL, to estimate the expenditures and savings generated in the CSP scenario. The data used by Excelergy to determine the expenditures and savings included the size of the plants to be built and the time periods for construction. Excelergy is an Excel spreadsheet-based model for solar parabolic trough systems that models annual plant performance and estimates capital and O&M costs. The data produced by Excelergy served as the input data for the macroeconomic analysis.

The study found that the “high CSP deployment” scenario would result in \$13 billion in investment, of which an estimated \$5.4 billion is estimated to be spent in California. Using RIMS II, the study found that this in-state investment would have a gross impact of \$24 billion on California GSP.

Georgia Energy Efficiency Potential Study

To assess opportunities for energy efficiency investments in the state of Georgia, the Georgia Environmental Facilities Authority undertook a prospective analysis of the macroeconomic effects of varying levels of investment in energy efficiency in Georgia from 2005–2015 (Jensen and Lounsbury, 2005).

The expenditure and savings data required for the Georgia study included the costs of energy efficiency equipment, customer energy bill savings, and program administration and incentive costs. To quantify these inputs, the study used ICF International's Energy Efficiency Potential Model (EPPM) to estimate the potential for energy efficiency improvements through program and policy interventions, and the expenditures and savings associated with realizing that potential.

The EPPM model provided a detailed view of which sectors, subsectors, and end uses provide the greatest opportunity for energy efficiency improvements in Georgia's economy by using end-use forecast data along with industry data on the costs, applicability, and longevity of energy efficiency measures. Within the model, the extent to which energy efficiency measures are adopted over time depends on the costs of energy efficiency measures relative to supply-side options and the intensity of the projected policy interventions. This relationship allowed the analysis to account for the energy savings and expenditures associated with efficiency investments and program administration, as well as the cost and revenue reductions experienced by utilities from reduced demand for electricity or gas.

Since Georgia-specific data for end-use forecasts and utility avoided costs were not publicly available, the study used regional data from various sources, including the U.S. Department of Energy, the Energy Information Administration, and IPM model projections. Results from EPPM and IPM were used as inputs to the Georgia Economic Modeling System (GEMS), developed by the University of Georgia, to estimate macroeconomic development effects.

The results of the GEMS analysis demonstrated that investments in energy efficiency in Georgia would generate economic benefits. Specifically, the study explored three policy scenarios to capture the energy efficiency potential identified for Georgia: a minimally aggressive scenario, a moderately aggressive scenario, and a very aggressive scenario. The study concluded that each scenario would achieve long-term net economic benefits in

Georgia including the creation of 1,500 to 4,200 new jobs and an increase in real disposable income of \$48 million to \$157 million by 2015 (Jensen and Lounsbury, 2005).

Southwest "High Efficiency" Study

The Southwest Energy Efficiency Project (SWEEP, 2002) analyzed the macroeconomic effects of investments in energy efficiency from 2003–2020 in southwestern states (including Arizona, Colorado, Nevada, New Mexico, Utah, and Wyoming). A "high efficiency" scenario was developed in the study by first establishing the expected level of energy savings and expenditures that would comprise this scenario.

In the residential and commercial sectors, SWEEP analyzed the energy savings and efficiency expenditures for the "high efficiency" scenario using the DOE-2.2 model, developed by James J. Hirsch & Associates in collaboration with the Lawrence Berkeley National Laboratory, accounting for specific building characteristics, energy use practices, state-by-state saturation and usage rates for end-uses, and other assumptions. This analysis included data from SWEEP, ACEEE, and EIA, among others.

In the industrial sector, SWEEP used the Long-Term Industrial Energy Forecasting (LIEF) model, along with U.S. Census and EIA data, to analyze the cost-effective electricity savings for the "high efficiency" scenario versus a base case scenario. LIEF is a model developed by the Argonne National Laboratory that uses three key factors to estimate the cost-effectiveness and adoption of energy efficiency measures in the industrial sector: (1) the assumed penetration rate, (2) the capital recovery factor, and (3) projected electricity prices. The LIEF model contains a number of cost assumptions for energy savings, and also has a number of parameters that the user can specify.

These analyses revealed, for example, that the "high efficiency" scenario would reduce average annual electricity demand growth from 2.6 percent in the base case to 0.7 percent, thereby reducing electricity consumption 33 percent by 2020 versus the base case. These and other savings would accrue with a total investment of \$9 billion from 2003–2020. The macroeconomic effects of these expenditures and savings were then evaluated for their direct, indirect, and induced effects using the IMPLAN input-output model. Among the findings of the IMPLAN analysis were increased regional employment of 58,400 jobs and increased regional personal income of \$1.34 billion per year by 2020 (SWEEP, 2002).

TABLE 5.2.5 SUMMARY OF ECONOMIC IMPACTS OF 2002 MASSACHUSETTS ENERGY EFFICIENCY PROGRAM ACTIVITIES

Electricity Bill Impacts	
Energy Savings	\$21.5 million
Total Participant Annual Energy Savings	14 years
Average Life of Energy Efficiency Measures	\$249 million
Total Participant Lifetime Energy Savings	\$138 million
Total Program Costs	4.0 ¢/kWh
Average Cost for Conserved Energy	
Demand Savings	\$1.2 million
Total Participant Annual Demand Savings	
Systems Impacts	
Savings to All Customers Due to Lower Wholesale Energy Clearing Prices	\$19.4 million
Economic Impacts	
Number of New Jobs Created in 2002	2,093
Disposable Income from Net Employment in 2002	\$79 million

Source: Division of Energy Resources, 2004.

Massachusetts Annual Report on Energy Efficiency

The Massachusetts Division of Energy Resources (DOER) produces an annual report analyzing the impacts of ratepayer-based energy efficiency programs in the state. The 2004 report is a retrospective analysis of the macroeconomic effects of investments in energy efficiency made in 2002 (DOER, 2004).

To perform the macroeconomic analysis, the DOER first determined the expenditures and savings for the 2002 investments. Program expenditures in 2002 included administration, marketing, program implementation, program evaluation, performance incentives paid to the distribution companies, and direct participant costs (2002 investments totaled \$138 million). Program administrators collect these data on a continuous basis. Savings included direct participant energy savings and electricity bill reductions, which were estimated using a combination of data from Massachusetts distribution companies, including participation rates, average energy use per participant, and electricity rate impacts for each customer sector specific to each electric distribution company service territory. The detailed expenditure and savings data were then

further disaggregated into industry-specific measures using Bill of Goods data developed by a contractor.

Using the expenditure and savings inputs, the DOER modeled the macroeconomic effects of 2002 program investments on employment, disposable income, and GSP using the REMI Policy Insight model. In addition, the DOER used those same expenditure and savings data in combination with the Energy 2020 model to project the lifetime energy savings of the 2002 program activities. Using these projected savings from Energy 2020 as inputs, the DOER used the Policy Insight model to estimate the future economic benefits reflected in Table 5.2.5.

5.2.3 STEP 3: APPLY THE METHOD TO QUANTIFY MACROECONOMIC EFFECTS

Once the direct expenditures and savings of a clean energy initiative have been quantified, the final step is to assess the aggregate macroeconomic effects of the initiative by applying the screening tool or modeling method selected in Step 1. With regard to policy implementation, many states have found the rigorous modeling methods outlined in Section 5.2.1 to be most effective in generating support for clean energy actions when a

robust assessment of the full range of effects (i.e., direct, indirect, and induced) is required. The application of economic impact models to measure the effects of energy efficiency and renewable energy policies is widely used and accepted across the nation (Sumi et al., 2003).

Regardless of the method, the macroeconomic effects of a clean energy initiative are usually quantified in comparison to a projected baseline scenario of economic activity. Constructing a base case scenario, or updating a default base case that may be included in the model, is generally the first step in the process of applying the macroeconomic analysis method.

Comparing the effects of the initiative to a baseline enables quantification of the overall net impacts of the initiative because the base case reflects what would have occurred in the initiative's absence. Typically, the baseline scenario characterizes a business-as-usual forecast of energy use patterns and economic growth within the state assuming the funds for the initiative are reallocated to other government programs or BAU consumer spending levels. If states choose to pursue one or more of these methods, the base case should be developed according to specifications associated with that particular method of analysis. This *Resource* does not explicitly cover methods for economic base case scenario development.

The remaining steps in applying the method depend on the method chosen and the state's customized modeling scenarios for their slate of clean energy initiatives. These attributes will, in turn, influence how the results of the analysis should be interpreted for policy purposes. The steps taken by Connecticut in the analysis of their conservation program are described in the text box *Steps in a Macroeconomic Impact Analysis: Connecticut's Oil and Natural Gas Conservation Policies*.

5.3 CASE STUDIES

5.3.1 NEW YORK: ANALYZING MACROECONOMIC BENEFITS OF THE ENERGY \$MARTSM PROGRAM

Benefits Assessed

- Net jobs and job years
- Personal income
- Total output
- Gross state product

STEPS IN A MACROECONOMIC IMPACT ANALYSIS: CONNECTICUT'S OIL AND NATURAL GAS CONSERVATION POLICIES

EPA and the State of Connecticut analyzed the impacts of Connecticut's proposed oil and natural gas conservation policies as part of the state's Climate Change Action Plan (CT GSC, 2004).

Step 1: Determine the method and level of effort

- Connecticut was interested in a *dynamic* analysis of both the *economic and demographic* impacts of these conservation policies over a 15-year time horizon.
- Connecticut contracted with Regional Economic Models, Inc. (REMI Policy Insight model) to model the policies because REMI's capabilities were consistent with its objectives and modeling needs.

Step 2: Quantify outlays and savings from the initiative

- The outlays and savings to be captured by the REMI Policy Insight model included oil and gas cost increases for users resulting from the surcharge on oil and natural gas; savings to oil and gas users due to reduced consumption of oil and natural gas; consumption reallocation of other consumer goods due to an increase in personal income; loss in sales to natural gas and oil firms due to reduced consumption; and investment in new equipment, construction, research, and other sectors.
- Data for the analysis were provided by an IPM study conducted for Connecticut, Northeast States for Coordinated Air Use Management (NESCAUM), Environment Northeast, Institute for Sustainable Energy, CT Department of Public Utility Control, CT Department of Environmental Protection, CT Clean Energy Fund, and United Technology Corporation.

Step 3: Apply the method to quantify macroeconomic benefits

- REMI developed a baseline forecast using a 53-sector model for Connecticut, along with three alternative conservation policy scenarios.
- The total macroeconomic effects of the policy scenarios were presented using the following indicators: employment, output, GSP, real disposable income, state revenues, and population changes.

The implementation of CT's proposed oil and natural gas conservation policy is pending legislative action.

Clean Energy Program Description

The New York Energy \$mart public benefits program, created in 1998 and administered by the New York State Energy Research and Development Authority, promotes energy efficiency across the commercial, industrial, and residential sectors; advances renewable energy; provides energy services to low income residents of New York; and conducts research and development (NYSERDA, 2009). The program has four overarching goals related

to improving the reliability of New York's energy system, reducing the energy costs for New Yorkers, mitigating environmental and health effects associated with energy use, and creating economic benefits for the state.

The Energy Smart Program (E\$P) is funded by a System Benefits Charge (SBC) on the state's investor-owned utilities and, since 1998, New York has spent more than \$1 billion to support it. The program's success and broad impact are products of a commitment to comprehensive evaluation, objective analysis, and collaboration in order "to ensure that the successes and failures of diverse programs are accurately and appropriately measured and reported" (NYSERDA, 2006b).

As part of that comprehensive evaluation process, NYSERDA produces an annual report detailing the multiple benefits of E\$P on both a retrospective and prospective basis. NYSERDA recognizes that program expenditures "have substantial macroeconomic impacts that go beyond these direct benefits" because the "...purchase of goods and services through the Program set off a ripple effect of spending and re-spending that influences many sectors of the New York economy, and the level and distribution of employment and income in the State" (NYSERDA, 2009). NYSERDA therefore conducts a periodic macroeconomic impact analysis to quantify the full range of macroeconomic impacts, expressed in terms of net annual employment, labor income, total industrial output, and value added.

Method(s) Used

For the 2009 analysis, NYSERDA used the REMI Policy Insight model, a macroeconomic model that combines elements of input-output, econometric, and computable general equilibrium models, to conduct the analysis.

New York estimated the positive and negative direct effects of the program associated with the program's expenditures and associated energy savings. These effects include:

- an increase in demand for clean energy-related goods and services,
- an increase in disposable income for residential customers due to the energy savings,
- a reduction in productivity costs for business customers whose energy costs have been reduced as a result of the programs,
- a decrease in disposable income for residents from paying the SBC,

- an increase in production costs for businesses from paying the SBC charge, and
- an increase in costs to residents and businesses from purchasing the clean-energy-related goods and services.

The data necessary to determine these effects have been collected since E\$P was implemented in 1999.

The analysis estimates historical macroeconomic impacts of the program from 1999 through 2008, and projects future impacts through 2022, assuming the program funding ends in 2008.

Results

The results of the macroeconomic impact analysis indicated that E\$P has provided and will continue to provide net benefits in the form of increased employment, personal income, total output, and gross state product.

The model indicated that E\$P initiatives implemented from 1999 through 2008 have already created 4,900 net jobs across the following sectors:

- 2,134 jobs in the Personal and Business Services sector,
- 841 in the Wholesale and Retail Trade sector,
- 794 in the Construction sector,
- 586 in the Transportation-related sector,
- 359 in State and Local Government, and
- 186 in Manufacturing.

During the same time period, the model showed that the program increased personal income by \$293 million, gross state product by \$644 million, and total output by \$1 billion.

The model was used to estimate the cumulative results projected out to 2020, assuming that funding stops in 2008. During this 24-year period, E\$P is expected to:

- Create 86,400 net job years,
- Increase personal income by \$5.75 billion,
- Increase gross state product by \$13.37 billion, and
- Increase total output by \$20.59 billion (NYSERDA, 2009).

NYSERDA evaluates E\$P's macroeconomic impacts, as well as the energy system and environmental and health benefits, as part of its ongoing and comprehensive evaluation strategy. The E\$P program analyses provide support for further development and implementation of clean energy initiatives. NYSERDA also collaborates with independent parties, partners with other government entities, and integrates its analyses into the public policy forum via a 24-member advisory group. NYSERDA's program underscores the importance of fully accounting for the multiple benefits of clean energy initiatives in establishing the basis for investment in energy efficiency and renewable energy.

For More Information

- *New York Energy \$martSM Program Evaluation and Status Report*. NYSERDA. Report to the System Benefits Charge Advisory Group. May, 2006. http://www.nysERDA.org/Energy_Information/06sbcreport.asp.

5.3.2 ILLINOIS: ANALYZING THE MACROECONOMIC BENEFITS OF CLEAN ENERGY DEVELOPMENT

Benefits Assessed

- Jobs
- Household income
- Business income

Clean Energy Program Description

In July 2005, the Illinois Commerce Commission voted to adopt a Sustainable Energy Plan, the culmination of years of work by the governor's *Special Task Force on the Condition and Future of the Illinois Energy Infrastructure*. The initial Sustainable Energy Plan (the "Plan") proposal included provisions for both renewable energy portfolio standards and energy efficiency portfolio standards, specifically:

- A Renewable Portfolio Standard (RPS) that required an increasing percentage of electricity sold to Illinois customers generated by renewable resources: 2 percent by 2006, and increasing annually by 1 percent until 2012.

The RPS further stipulated, as determined by the study, that 75 percent of the renewable generation should come from wind resources.

- An Energy Efficiency Portfolio Standard (EEPS) that required electricity load growth to be reduced by the following amounts each year: 10 percent of projected load growth in 2006–2008, 15 percent in 2009–2011, 20 percent in 2012–2014, and 25 percent in 2015–2017.

The Illinois Commerce Commission's decision to adopt the Plan followed more than five months of public comment and deliberation among many stakeholders, including utility companies and public interest groups. Ultimately, the decision was largely guided by the proposed Plan's substantial benefits, which were quantified in a study released by the Energy Resources Center at the University of Illinois in June of 2005 (Bournakis and Hewings et al., 2005).

Method(s) Used

The direct and indirect macroeconomic impacts of the Plan's provisions were analyzed using the Illinois Regional Economic Input-Output Model (ILREIM).⁹

ILREIM includes two components, an input-output model and an econometric model. The model links the regional input-output component with macroeconomic and demographic variables in a dynamic framework that is able to examine the feedback effects of economic events with different sectors.

More specifically, this model is a system of linear equations formulated to predict the behavior of 151 endogenous variables, and consists of 123 behavioral equations, 28 accounting identities, and 68 exogenous variables. The model identifies 53 industries and three government sectors.

For each industry in the structure, the model projects output, employment, and earnings. The model also estimates GSP, personal consumption expenditures, investment, state and local government expenditures, exports, labor force, unemployment rate, personal income, net migration, population, and the consumer price index.

To run ILREIM, the researchers provided data describing the dollar value of energy savings, the actual electricity savings, and the various investments needed to support the RPS and EEPS described in the Plan. The scenarios that were run included large investments in ef-

⁹ Looking at the models described in Table 5.2.4, ILREIM is more like REMI than IMPLAN or RIMS II.

efficiency equipment and large investments in renewable generation facilities relative to the baseline scenario.

Results

The University of Illinois analysis found, among other benefits, that by 2012 the Plan would:

- create 7,800 jobs and
- generate nearly \$9 billion in additional household and business income.

In addition, the study also revealed other results:

- The state would experience an economic adjustment composed of the interplay between the reduced local production of fossil-fuel energy and the increased production of efficiency equipment (it is likely that some portions of the efficiency equipment will be manufactured in Illinois).
- Part of the saved energy will come from reduced energy imports.
- Non-local impacts will affect the economies of other states.

As indicated in the Illinois Commerce Commission's Resolution¹⁰ to adopt the Plan, the realization (within the Commission and among interested stakeholders) that the Plan would "lead to rural economic development" and create other environmental benefits was a key factor in the Plan's final implementation. Furthermore, the transparent, detailed, and comprehensive nature of the benefits study assured that, even after an extensive review and comment period, the Plan ultimately adopted by the Commission was nearly identical to the governor's original proposal.

For More Information

- *The Economic and Environmental Impacts of Clean Energy Development in Illinois*. Bournakis, A., G. Hewings, J. Cuttica, and S. Mueller. Submitted to the Illinois Department of Commerce and Economic Opportunity. June, 2005. http://www.erc.uic.edu/PDF/Clean_Energy_Development.pdf.

¹⁰ ICC Resolution 05-0437, available at: <http://www.dsireusa.org/documents/Incentives/IL04R.pdf>

Sampling of State Clean Energy Analyses by Type of Analytic Method

Reference	State/Region	URL Address
State-level Clean Energy Analyses that Used I-O Analyses		
Grover, S. 2007. Economic Impacts of Oregon Energy Tax Credit Programs (BETC/RETC). Prepared by ECONorthwest for the Oregon Department of Energy. May.	Oregon	http://www.oregon.gov/ENERGY/CONS/docs/EcoNW_Study.pdf
Nayak, N. 2005. Redirecting America's Energy: The Economic and Consumer Benefits of Clean Energy Policies. Prepared by the U.S. PIRG Education Fund. February.	U.S.	http://newenergyfuture.com/newenergy.asp?id2=15905&id3=energy&#2
Pletka, R. 2004. Economic Impact of Renewable Energy in Pennsylvania. Prepared by Black & Veatch for The Heinz Endowments and Community Foundation for the Alleghenies. March.	Pennsylvania	http://www.bv.com/Downloads/Resources/Reports/PA_RPS_Final_Report.pdf
RAP. 2005. Electric Energy Efficiency and Renewable Energy in New England: An Assessment of Existing Policies and Prospects for the Future. Prepared by The Regulatory Assistance Project and Synapse Energy Economics, Inc. May.	New England	http://www.raonline.org/Pubs/RSWS-EEandREinNE.pdf
Stoddard, L., J. Abiecunas, and R. O'Connell. 2006. Economic, Energy, and Environmental Benefits of Concentrating Solar Power in California. Prepared by Black & Veatch for U.S. DOE National Renewable Energy Laboratory. April.	California	http://www.nrel.gov/docs/fy06osti/39291.pdf
U.S. DOC. 2003. Developing a Renewable Energy Based Economy for South Texas – A Blueprint for Development. U.S. Department of Commerce, Economic Development Administration, and the University of Texas at San Antonio.	Texas	http://www.solarsanantonio.org/pdf/EDARreport.pdf

Sampling of State Clean Energy Analyses by Type of Analytic Method

Reference	State/Region	URL Address
SWEET. 2002. The New Mother Lode: The Potential for More Efficient Electricity Use in the Southwest. Southwest Energy Efficiency Project, Report for the Hewlett Foundation Energy Series. November.	Southwest	http://www.swenergy.org/nml
State-Level Clean Energy Analysis that Used Econometric Models		
Bernstein, M., C. Pernin, S. Loeb, and M. Hanson. 2000. The Public Benefit of California's Investments in Energy Efficiency. Prepared by RAND Science and Technology for California Energy Commission. March.	California	http://rand.org/pubs/monograph_reports/2005/MR1212.0.pdf
Bernstein, M., R. Lempert, D. Loughram, and D. Ortiz. 2002a. The Public Benefit of Energy Efficiency to the State of Massachusetts. Prepared by RAND Science and Technology.	Massachusetts	http://www.rand.org/pubs/monograph_reports/2005/MR1588.pdf
Bernstein, M., R. Lempert, D. Loughram, and D. Ortiz. 2002b. The Public Benefit of Energy Efficiency to the State of Minnesota. Prepared by RAND Science and Technology.	Minnesota	http://www.rand.org/pubs/monograph_reports/2005/MR1587.pdf
Bernstein, M., R. Lempert, D. Loughram, and D. Ortiz. 2002c. The Public Benefit of Energy Efficiency to the State of Washington. Prepared by RAND Science and Technology for the Energy Foundation. February.	Washington	http://www.rand.org/pubs/monograph_reports/2005/MR1589.pdf
State-Level Clean Energy Analysis that Used Computable General Equilibrium Models		
Roland-Holst, D. University of California Berkeley. Economic Assessment of some California Greenhouse Gas Control Policies: Applications of the BEAR Model. No date given.	California	http://calclimate.berkeley.edu/research/ghg/assets/2_Economic_Assessment.pdf
State-Level Clean Energy Analysis that Used Hybrid Models		
Bournakis, A., G. Hewings, J. Cuttica, and S. Mueller. 2005. The Economic and Environmental Impacts of Clean Energy Development in Illinois. Submitted to the Illinois Department of Commerce and Economic Opportunity. June.	Illinois	http://www.erc.uic.edu/PDF/Clean_Energy_Development.pdf
CT GSC. 2004. 2005 Climate Change Action Plan, Appendix 9: Economic Impact of Oil and Natural Gas Conservation Policies. Connecticut Governor's Steering Committee, prepared by Regional Economic Models, Inc. November.	Connecticut	http://www.ctclimatechange.com/documents/Appendix9_REMI_HeatingOilandNaturalGasConservationFunds_CCCAP_2005_000.pdf
DOER. 2004. 2002 Energy Efficiency Activities. Massachusetts Division of Energy Resources.	Massachusetts	http://www.mass.gov/Eoca/docs/doer/pub_info/ee02-long.pdf
Hewings, G., and M. Yanai, 2002. Job Jolt: The Economic Impacts of Repowering the Midwest. Prepared by the Regional Economics Applications Laboratory.	Midwest	http://www.issuelab.org/research/job_jolt_the_economic_impacts_of_repowering_the_midwest
Jensen, V., and E. Lounsbury. 2005. Assessment of Energy Efficiency Potential in Georgia. Prepared for the Georgia Environmental Facilities Authority by ICF Consulting. May.	Georgia	http://www.gefa.org/Modules/ShowDocument.aspx?documentid=46
NYSERDA. 2009. New York Energy Smart Program Evaluation and Status Report; Year Ending December 31, 2008, Report to the Systems Benefit Charge Advisory Group, Final Report, March.	New York	http://www.nyserda.org/publications/SBC%20March%202009%20Annual%20Report.pdf

Sampling of State Clean Energy Analyses by Type of Analytic Method

Reference	State/Region	URL Address
Sumi, D., G. Weisbrod, B. Ward, and M. Goldberg. 2003. An Approach to Quantifying Economic and Environmental Benefits for Wisconsin's Focus on Energy. Presented at International Energy Program Evaluation Conference. August.	Wisconsin	http://edrgroup.com/pdf/sumi-weisbrod-wis-energy-iepec.pdf
Weisbrod, G., K. Polenske, T. Lynch, and X. Lin. 1995. The Economic Impact of Energy Efficiency Programs and Renewable Power for Iowa: Final Report. Economic Development Research Group, Boston, MA. December.	Iowa	http://www.edrgroup.com/library/energy-environment/iowa-energy.html

Information Resources	URL Address
The American Council for an Energy Efficient Economy (ACEEE)	http://www.aceee.org/
Energy 2020 model	http://www.energy2020.com/model_overview.htm
ICF International Inc. IPM model	http://www.icfi.com/Markets/Energy/energy-modeling.asp#2
Minnesota IMPLAN Group, Inc. IMPLAN model	http://www.implan.com/
Regional Economic Modeling, Inc. REMI model	http://www.remi.com/
REPP Labor Calculator	http://www.crest.org/
Rocky Mountain Institute Community Energy Opportunity Finder tool	http://www.energyfinder.org/
RTI International Applied Dynamic Analysis of the Global Economy (ADAGE) model	http://www.rti.org/page.cfm?objectid=DDC06637-7973-4B0F-AC46B3C69E09ADA9
U.S. Bureau of Economic Analysis Regional Economic Accounts	http://www.bea.gov/regional/index.htm
U.S. Census Bureau	http://www.census.gov/
U.S. Department of Commerce RIMS II model	https://www.bea.gov/regional/rims/
U.S. DOE Argonne National Laboratory Long-Term Industrial Energy Forecasting (LIEF) model	http://www.dis.anl.gov/projects/EnergyAnalysisTools.html#lief
U.S. DOE Lawrence Berkeley National Laboratory DOE-2.2 model	http://www.doe2.com/
U.S. DOE National Renewable Energy Laboratory Excelergy model	http://www.nrel.gov/
U.S. DOE National Renewable Energy Laboratory Jobs and Economic Development Impact (JEDI) tool	http://www.nrel.gov/analysis/jedi/
U.S. Energy Information Administration	http://www.eia.doe.gov/
University of Georgia, Georgia Economic Modeling Systems (GEMS)	http://www.cviog.uga.edu/
University of Illinois, Regional Economics Applications Laboratory (REAL)	http://www.real.uiuc.edu/

References	URL Address
Bernstein, M., C. Pernin, S. Loeb, and M. Hanson. 2000. The Public Benefit of California's Investments in Energy Efficiency. Prepared by RAND Science and Technology for California Energy Commission. March.	http://rand.org/pubs/monograph_reports/2005/MR1212.0.pdf

References	URL Address
Bernstein, M., R. Lempert, D. Loughram, and D. Ortiz. 2002a. The Public Benefit of Energy Efficiency to the State of Massachusetts. Prepared by RAND Science and Technology.	http://www.rand.org/pubs/monograph_reports/2005/MR1588.pdf
Bernstein, M., R. Lempert, D. Loughram, and D. Ortiz. 2002b. The Public Benefit of Energy Efficiency to the State of Minnesota. Prepared by RAND Science and Technology.	http://www.rand.org/pubs/monograph_reports/2005/MR1587.pdf
Bernstein, M., R. Lempert, D. Loughram, and D. Ortiz. 2002c. The Public Benefit of Energy Efficiency to the State of Washington. Prepared by RAND Science and Technology for the Energy Foundation. February.	http://www.rand.org/pubs/monograph_reports/2005/MR1589.pdf
Bohringer, C. 1998. The Synthesis of Bottom-Up and Top-Down in Energy Policy Modeling. <i>Energy Economics</i> , v. 20, pg. 223-248.	http://www.elsevier.com/wps/find/journaldescription.cws_home/30413/description#description
Bournakis, A., G. Hewings, J. Cuttica, and S. Mueller. 2005. The Economic and Environmental Impacts of Clean Energy Development in Illinois. Submitted to the Illinois Department of Commerce and Economic Opportunity. June.	http://www.erc.uic.edu/PDF/Clean_Energy_Development.pdf
Cinnamon, B., T. Beach, M. Huskins, and M. McClintock. 2005. The Economics of Solar Power for California. August.	http://akeena.net/Library/pdfs/Economics_of_Solar_Power_for_California_Aug2005.pdf
CT GSC. 2004. 2005 Climate Change Action Plan, Appendix 9: Economic Impact of Oil and Natural Gas Conservation Policies. Connecticut Governor's Steering Committee, prepared by Regional Economic Models, Inc. November.	http://www.ctclimatechange.com/documents/Appendix9_REMI_HeatingOilandNaturalGasConservationFunds_CCCAP_2005_000.pdf
Department of Administration (DOA), State of Wisconsin. 2001. Focus on Energy Pilot Study: Demonstration of Economic Impact Analysis for Commercial & Industrial Programs. Prepared by Economic Development Research Group, Inc. September.	http://www.edrgroup.com/pdf/Wis-Pilot-Report.pdf
DOER. 2004. 2002 Energy Efficiency Activities. Massachusetts Division of Energy Resources.	http://www.mass.gov/Eoca/docs/doer/pub_info/ee02-long.pdf
Goldberg, M., K. Sinclair, and M. Milligan. 2004. Job and Economic Development Impact (JEDI) Model: A User-Friendly Tool to Calculate Economic Impacts from Wind Projects. Presented at the 2004 Global WINDPOWER Conference, Chicago, Illinois. March.	http://www.nrel.gov/docs/fy04osti/35953.pdf
Grover, S. 2007. Economic Impacts of Oregon Energy Tax Credit Programs in 2006 (BETC/RETC). Prepared by ECONorthwest for the Oregon Department of Energy. May.	http://www.oregon.gov/ENERGY/CONS/docs/EcoNW_Study.pdf
Heavner, B. and B. Del Chiaro. 2003. Renewable Energy and Jobs: Employment Impacts of Developing Markets for Renewables in California. Environment California Research and Policy Center. July.	http://www.environmentcalifornia.org/uploads/OW/aa/OWaa2RaedlfHwQOWbxKd5w/Renewable_Energy_and_Jobs.pdf
Hewings, G., and M. Yanai, 2002. Job Jolt: The Economic Impacts of Repowering the Midwest. Prepared by the Regional Economics Applications Laboratory.	http://www.issuelab.org/research/job_jolt_the_economic_impacts_of_repowering_the_midwest
IREC. 2005. Labor Forecasts and Job Trends for the Solar and Renewable Energy Industries. Interstate Renewable Energy Council Notebook, Version #5. January.	http://www.irecusa.org/index.php?id=6
Jensen, V., and E. Lounsbury. 2005. Assessment of Energy Efficiency Potential in Georgia. Prepared for the Georgia Environmental Facilities Authority by ICF Consulting. May.	www.gefa.org/Modules/ShowDocument.aspx?documentid=46

References	URL Address
Loschel, A. 2002. Technological Change in Economic Models of Environmental Policy: A Survey. <i>Ecological Economics</i> , v. 43	http://www.elsevier.com/locate/ecoecon
Mongha, N., E. Stafford, and C. Hartman. 2006. An Analysis of the Economic Impact on Utah County, Utah from the Development of Wind Power Plants. <i>Renewable Energy for Rural Economic Development</i> , Utah State University. DOE/GO-102006-2316. May.	http://www.eere.energy.gov/windandhydro/windpoweringamerica/pdfs/wpa/econ_dev_jedi.pdf
MTC. 2005. Energy Efficiency, Renewable Energy, and Jobs in Massachusetts. Massachusetts Technology Collaborative, Renewable Energy Trust. November.	http://www.masstech.org/IS/reports/clusterreport11405.pdf
Nayak, N. 2005. Redirecting America's Energy: The Economic and Consumer Benefits of Clean Energy Policies. Prepared by the U.S. PIRG Education Fund. February.	http://newenergyfuture.com/newenergy.asp?id2=15905&id3=energy&#2
Nevada AFL-CIO. Comments Submitted to the Nevada Public Service Commission: Procedural Order No. 3 and Request for Comments No. 2.	http://www.repp.org/articles/static/1/binaries/Nevada_RPS.pdf
New York Office of the Governor. 2003. Press Release: Governor Announces \$14.5 Million for Clean Energy Projects. July 18, 2003.	http://www.nyserda.org/Press_Releases/press_archives/2003/governor/govjuly18_03.asp
NJ BPU. 2005. New Jersey's Clean Energy Program: 2005 Annual Report. New Jersey Board of Public Utilities, Office of Clean Energy.	http://www.njcleanenergy.com/files/file/2005%20Annual%20Report.pdf
NYSERDA. 2006a. Press Release: State Energy Authority Announces Partnership that will Lead to the Growth of Clean-Energy and Environmental Technologies in New York State. July 5.	http://www.nyserda.org/Press_Releases/2006/PressRelease20060507.asp
NYSERDA. 2006b. New York Energy Smart Program Evaluation and Status Report: Report to the Systems Benefits Charge Advisory Group. May.	http://www.nyserda.org/Energy_Information/06sbcreport.asp
NYSERDA. 2008. New York Energy Smart Program Evaluation and Status Report; Year Ending December 31, 2007, Report to the Systems Benefit Charge Advisory Group, Final Report, March.	http://www.nyserda.org/pdfs/Combined%20Report.pdf
NYSERDA. 2009. New York Energy Smart Program Evaluation and Status Report; Year Ending December 31, 2008, Report to the Systems Benefit Charge Advisory Group, Final Report, March.	http://www.nyserda.org/publications/SBC%20March%202009%20Annual%20Report.pdf
Pletka, R. 2004. Economic Impact of Renewable Energy in Pennsylvania. Prepared by Black & Veatch for The Heinz Endowments and Community Foundation for the Alleghenies. March.	http://www.bv.com/Downloads/Resources/Reports/PA_RPS_Final_Report.pdf
RAP. 2005. Electric Energy Efficiency and Renewable Energy in New England: An Assessment of Existing Policies and Prospects for the Future. Prepared by The Regulatory Assistance Project and Synapse Energy Economics, Inc. May.	http://www.raonline.org/Pubs/RSWS-EEandREinNE.pdf
REMI. 2004. Economic Impact of Oil and Natural Gas Conservation Policies. Prepared for U.S. Environmental Protection Agency and the State of Connecticut. November.	http://ctclimatechange.com/documents/Appendix9_REMI_HeatingOilandNaturalGasConservationFunds_CCCAP_2005_000.pdf
REPP. 2005. Component Manufacturing: Ohio's Future in the Renewable Energy Industry. Renewable Energy Policy Project. October.	http://www.repp.org/articles/static/1/binaries/Ohio_Manufacturing_Report_2.pdf
Roland-Holst, D. 2006. University of California Berkeley. Economic Assessment of some California Greenhouse Gas Control Policies: Applications of the BEAR Model. August.	http://calclimate.berkeley.edu/research/ghg/assets/2_Economic_Assessment.pdf

References	URL Address
Roland-Holst, D. Economic Growth and Greenhouse Gas Mitigation in California. August 2006. UC Berkeley	http://utahcleanenergy.org/files/u1/d_GHG_Mitigation_in_CA_Exec_Summ_UC_Berkeley.pdf
Spitzer, E. 2007. "15 by 15" A Clean Energy Strategy for New York. Speech by former Governor Spitzer, April 19.	http://www.state.ny.us/governor/keydocs/0419071_speech.html
Stoddard, L., J. Abiecunas, and R. O'Connell. 2006. Economic, Energy, and Environmental Benefits of Concentrating Solar Power in California. Prepared by Black & Veatch for U.S. DOE National Renewable Energy Laboratory. April.	http://www.nrel.gov/docs/fy06osti/39291.pdf
Sue Wing, I. 2004. Computable General Equilibrium Models and Their Use in Economy-Wide Policy Analysis: Everything You Ever Wanted to Know (But Were Afraid to Ask). MIT Joint Program on the Science and Policy of Global Change. Technical Note No. 6, September.	http://mit.edu/globalchange/www/MITJPSPGC_TechNote6.pdf
Sumi, D., G. Weisbrod, B. Ward, and M. Goldberg. 2003. An Approach to Quantifying Economic and Environmental Benefits for Wisconsin's Focus on Energy. Presented at International Energy Program Evaluation Conference. August.	http://edrgroup.com/pdf/sumi-weisbrod-wis-energy-iepec.pdf
SWEEP. 2002. The New Mother Lode: The Potential for More Efficient Electricity Use in the Southwest. Southwest Energy Efficiency Project, Report for the Hewlett Foundation Energy Series. November.	http://www.swenergy.org/nml
U.S. DOC. 2003. Developing a Renewable Energy Based Economy for South Texas – A Blueprint for Development. U.S. Department of Commerce, Economic Development Administration, and the University of Texas at San Antonio.	http://www.solarsanantonio.org/pdf/EDARReport.pdf
U.S. EPA. 2006. National Action Plan for Energy Efficiency. Office of Air and Radiation, Climate Protection Partnerships Division. July.	http://www.epa.gov/cleanenergy/documents/napee/napee_report.pdf
Weisbrod, G., K. Polenske, T. Lynch, and X. Lin. 1995. The Economic Impact of Energy Efficiency Programs and Renewable Power for Iowa: Final Report. Economic Development Research Group, Boston, MA. December.	http://www.edrgroup.com/library/energy-environment/iowa-energy.html
Wisconsin Department of Administration. 2007. Division of Energy. Focus on Energy Public Benefits Evaluation. Economic Development Benefits: FY07 Economic Impacts Report. Final: February 23, 2007.	http://www.focusonenergy.com/data/common/dmsFiles/EC_RPTI_Econ_Dev_Benefits_FY07.pdf

APPENDIX A

Catalogue of Clean Energy Case Studies Highlighted in the Multiple Benefits Guide

DOCUMENT MAP

- CHAPTER ONE
Introduction
- CHAPTER TWO
Potential Energy Impacts of Clean Energy
- CHAPTER THREE
Electric System Benefits of Clean Energy
- CHAPTER FOUR
Air Quality Benefits of Clean Energy
- CHAPTER FIVE
Economic Benefits of Clean Energy
- **APPENDIX A**
Catalogue of Clean Energy Case Studies
- APPENDIX B
Tools and Models Referenced in Each Chapter

CATALOGUE OF CLEAN ENERGY CASE STUDIES HIGHLIGHTED IN THE MULTIPLE BENEFITS GUIDE

Chapter 1: Introduction							
Case Studies			Key Benefits Findings, Results and Activities				
State/Region and Name of Program	Summary of Policy/Program and Analysis	Link	Energy	Emissions, Air Quality, and Health	Economic	Time Period for Analysis	Type of Analysis*
Connecticut: Incorporating Multiple Benefits in Evaluation Criteria for New Capacity Additions	<p>In June 2005, Connecticut policymakers enacted Public Act 05-01, An Act Concerning Energy Independence (EIA), which authorized the Connecticut Department of Public Utility Control to launch a competitive procurement process geared toward motivating new supply-side and demand-side resources.</p> <p>As part of the bid evaluation process, each capacity project is scored based on a multiple benefits weighting system: A total of 85% of the evaluation score is based on a benefit-cost analysis of the project. A total of 15% of the evaluation score is determined through the assessment of five other criteria with their associated weights (see benefits, right).</p>	Connecticut Climate Change 2005 Connecticut Climate Action Plan	<ul style="list-style-type: none"> • Use of existing sites and infrastructure – 2.5% • Benefits of fuel diversity – 2.5% <p>Other benefits (e.g., transmission reliability, employment effects, benefits of high level efficiency such as CHP) – 2.5%</p>	Reduced emissions of SO ₂ , NO _x , and CO ₂ – 5%	Front-loading of costs – 2.5%	2005–2020	P
Ohio: Clean Energy Initiatives Can Benefit Economic Development	<p>A 2007 study by the American Solar Energy Society assessed the renewable energy and energy efficiency market and developed forecasts of the market's future economic growth. The study established a baseline of 2006 and forecast the growth of the renewable energy and energy efficiency industry from this baseline to 2030 under three different scenarios. Using this approach, the authors developed a case study for Ohio, an area hard hit by the loss of manufacturing jobs. The analysis concluded that the energy efficiency and renewable energy industries offer significant development opportunities in the state.</p>	Bezdek, Roger. 2007. Renewable Energy and Energy Efficiency: Economic Drivers for the 21st Century. Prepared for the American Solar Energy Society.			<p>In 2030:</p> <ul style="list-style-type: none"> • \$18 billion in revenues and 175,000 jobs annually in the renewable energy industry • \$200 billion in revenues and more than 2 million jobs in the energy efficiency industry 	2006–2030	P

* P = Prospective; R= Retrospective

Chapter 1: Introduction

Case Studies			Key Benefits Findings, Results and Activities				
State/Region and Name of Program	Summary of Policy/Program and Analysis	Link	Energy	Emissions, Air Quality, and Health	Economic	Time Period for Analysis	Type of Analysis*
<p>Multiple States: Reducing Natural Gas Prices through Increased Deployment of Renewable Energy and Energy Efficiency</p>	<p>A recent study by the Lawrence Berkeley National Laboratory (LBNL) examined several studies of the natural gas consumer benefits from clean energy programs. Most of the studies evaluated a national or state RPS, or a combined RPS and EE program and consistently showed that “RE and EE deployment will reduce natural gas demand, thereby putting downward pressure on gas prices” (Wiser et al., 2005).</p>	<p>Wiser, R., M. Bolinger, and M. Clair. 2005. Easing the Natural Gas Crisis: Reducing Natural Gas Prices through Increased Deployment of Renewable Energy and Energy Efficiency. Ernest Orlando Lawrence Berkeley National Laboratory (LBNL). January.</p>			<ul style="list-style-type: none"> • Each 1% reduction in national gas demand is likely to lead to a long-term average reduction in wellhead gas prices of 0.8% to 2%. • The present value of natural gas bill savings from 2003-2020 are within the range of \$10 - \$40 billion. • Consumers’ gas bill savings are estimated between \$7.50 and \$20 for each MWh of electricity produced by RE or saved with EE. 	2003–2020	P
<p>Multiple States: How Many Jobs Can the Clean Energy Industry Generate?</p>	<p>In 2004 the University of California-Berkeley reviewed 13 independent reports and developed a model to examine the job creation potential of the renewable energy industry.</p> <p>The study analyzed the employment implications of three national 20% RPS scenarios and two scenarios where the generation required by the RPS is produced instead by fossil-fuel generation.</p>	<p>Kammen, D., K. Kapadia, M. Fripp. 2004. Putting Renewables to Work: How Many Jobs Can the Clean Energy Industry Generate? April.</p>			<ul style="list-style-type: none"> • The RE industry generates more jobs than the fossil-fuel industries per unit of energy delivered and per dollar invested, driven primarily by the general shift from mining and related services to increased manufacturing, construction, and installation activity. 	1998–2004	R

* P = Prospective; R= Retrospective

Chapter 1: Introduction

Chapter 1: Introduction							
Case Studies			Key Benefits Findings, Results and Activities				
State/Region and Name of Program	Summary of Policy/Program and Analysis	Link	Energy	Emissions, Air Quality, and Health	Economic	Time Period for Analysis	Type of Analysis*
New England and NE Canada: Multiple Benefits Analysis is Being Used in Regional Planning	<p>The Conference of New England Governors and Eastern Canadian Premiers (NEG-ECP) developed a comprehensive Climate Change Action Plan in 2001 with the long-term goal of reducing GHG emissions in the region by 75–85% and enacted Policy Resolution 30-2 to promote energy efficiency and renewable energy in the region.</p> <p>A study, Electric Energy Efficiency and Renewable Energy In New England: An Assessment of Existing Policies and Prospects for the Future, estimates that by 2010, the combined effect of expected energy efficiency and renewable energy deployment will provide a wide range of benefits that go beyond direct energy savings.</p>	New England Governors and Eastern Canadian Premiers (NEG-ECP). 2006. Resolution 30-2: Resolution Concerning Energy. May.	<p>Energy security benefits between 2000 and 2010 included:</p> <ul style="list-style-type: none"> • A stabilizing and reducing influence on the wholesale price of, and demand for, natural gas • Reduced wholesale electricity prices in the regional market • Reduced demand for new facilities in the electric market • Increased resiliency of the grid 	<p>Estimated environmental benefits between 2000 and 2010 included:</p> <ul style="list-style-type: none"> • savings of 31.6 million tons of CO2 emissions • 22,000 tons of NOX emissions • 34,000 tons of SO2 emissions 	<p>Estimated economic benefits between 2000 and 2010 included:</p> <ul style="list-style-type: none"> • A net positive \$6.1 billion for the New England economy • More than 28,000 job-years • \$1 billion in wages 	2000–2010	R and P

Chapter 2: Assessing the Potential Energy Impacts of Clean Energy Initiatives Programs

Chapter 2: Assessing the Potential Energy Impacts of Clean Energy Initiatives Programs							
Case Studies			Key Benefits Findings, Results and Activities				
State/Region and Name of Program	Summary of Policy/Program and Analysis	Link	Energy	Emissions, Air Quality, and Health	Economic	Time Period for Analysis	Type of Analysis*
New Jersey: Energy Plan-Basic Demand Forecast	<p>The New Jersey energy plan-basic demand forecast projected the electricity growth rate for all sectors for 2005-2020. This study illustrates an example of a linear extrapolation analysis.</p> <p>The BAU electricity forecast was developed using a relatively simple approach in which past load growth rates were reviewed and assumptions were made regarding the ways in which industry trends and existing policies affect future growth patterns.</p>	Summit Blue Consulting. 2008. Assessment of the New Jersey Renewable Energy Market, Volume I and II. Prepared for the New Jersey Board of Public Utilities. March.	<ul style="list-style-type: none"> • The electricity growth rate for all sectors from 2005-2020 is projected to be 1.52% 			2005–2020	P

* P = Prospective; R= Retrospective

Chapter 2: Assessing the Potential Energy Impacts of Clean Energy Initiatives Programs

Case Studies			Key Benefits Findings, Results and Activities				
State/Region and Name of Program	Summary of Policy/Program and Analysis	Link	Energy	Emissions, Air Quality, and Health	Economic	Time Period for Analysis	Type of Analysis*
New York: Energy SmartSM Public Benefits Program	<p>New York's public benefit program was established by order of the New York State Public Service Commission (PSC) in January 1998 and funded by the System Benefits Charge (SBC). New York State Energy Research and Development Authority (NYSERDA) administers the New York Energy SmartSM Program which promotes competitive markets for energy efficiency services, provides direct benefits to electricity ratepayers and/or to the people of New York and stimulates demand for energy-efficient products and services, and renewable resource technologies.</p> <p>In this study, NYSEDA uses a production costing model, MAPS, to forecast the avoided energy and capacity benefits of the programs for several years.</p>	<p>NYSERDA. 2005. <u>New York Energy SmartSM Program. Evaluation and Status Report for the Year Ending December 2004. New York Public Service Commission and New York State Energy Research and Development Authority. May.</u></p> <p>NYSERDA. 2008. <u>New York Energy SmartSM Program. Evaluation and Status Report for the Year Ending December 2007. New York Public Service Commission and New York State Energy Research and Development Authority. March.</u></p>	<p>Electricity savings of:</p> <ul style="list-style-type: none"> • 1,400GWh between 1998-2004 • 3,000 GWh savings by 2007 	<ul style="list-style-type: none"> • Reduced nearly 2,600 and 4,700 tons of NO_x and SO_x respectively • Decreased annual CO₂ emissions by 2 million tons 	<p>Between 1998-2004:</p> <ul style="list-style-type: none"> • Saved \$195 million in energy costs • Reduced annual energy bills by \$570 million <p>Created and retained 4,700 jobs</p> <p>By 2027 the program is expected to:</p> <ul style="list-style-type: none"> • Create more than 7,200 jobs • Increase labor income more than \$300 million each year • Increase total annual output in the state by \$503 million 	1998–2027	R and P
Texas: Building Code	<p>The legislation (Senate Bill 5, 2001) that initiated the Texas Emissions Reduction Plan (TERP) requires the Energy Systems Laboratory (ESL) at the Texas Engineering Experiment Station of the Texas A&M University System to submit an annual report to the Texas Commission on Environmental Quality estimating the historical and potential future energy savings from energy building code adoption and, when applicable, from more stringent local codes or above-code performance ratings.</p> <p>Using data from the TCEQ and EPA, including eGRID, ESL estimated the energy savings and NO_x reductions from energy code compliance in new residential construction. ESL has conducted this annual analysis since 2002.</p>	<p>Texas A&M Energy Systems Laboratory (ESL). 2007. <u>Energy Efficiency/Renewable Energy Impact in the Texas Emissions Reduction Plan (TERP). Volume II- Technical Report.</u></p>	<p>Annual Energy Savings:</p> <ul style="list-style-type: none"> • 1,440,885 MWh of electricity each year • Approximately 2.9 million MWh by 2013 	<p>NO_x emissions reduced by:</p> <ul style="list-style-type: none"> • 1,014 tons-NO_x/year in 2007 • 2,047 tons/year by 2013 		1998–2027	P

* P = Prospective; R= Retrospective

Chapter 2: Assessing the Potential Energy Impacts of Clean Energy Initiatives Programs

Case Studies			Key Benefits Findings, Results and Activities				
State/Region and Name of Program	Summary of Policy/Program and Analysis	Link	Energy	Emissions, Air Quality, and Health	Economic	Time Period for Analysis	Type of Analysis*
Vermont: Energy and Energy Savings Forecasting	<p>The Vermont Department of Public Service (DPS) conducts forecasting as a part of its long-term state energy policy and planning process. The state uses the Comprehensive Energy Plan (CEP) to help manage the transition from fossil fuels to cleaner energy in order to benefit Vermont's economic and environmental future.</p> <p>An analysis performed in 2008 included an examination of historical energy consumption across all sectors 1960-2005. The forecasting process required the following steps: 1) Determine fuel price projections and avoided costs; 2) Estimate the achievable, cost-effective potential for electric energy and peak demand savings; 3) Develop a 20-year forecast of electric energy use; and 4) Develop a peak demand forecast. It also employed historical data to compare energy demand in Vermont with New England from 1990-2004.</p>	Vermont's Energy Forecasting Efforts. Vermont Department of Public Service. June 19, 2008	<ul style="list-style-type: none"> Electricity demand is expected to grow an average of 0.93% on an average annual basis 2008-2028. When new DSM measures are implemented, DPS anticipates a decline of 0.19% on an average annual basis. 		<ul style="list-style-type: none"> Due to forecasts of a large supply gap with high costs to replace power contracts, Vermont committed itself to pursue very aggressive energy efficiency measures. 	1960–2005	P
Wisconsin: Office of Energy Independence: Demand & supply baselines & energy consumption by fuel type data	<p>In 2006, then-Wisconsin Governor Jim Doyle launched the <i>Declaration of Energy Independence</i>, which included a goal of using renewable energy to generate 25 percent of the state's electricity and 25 percent of its transportation fuels by 2025. It uses a top-down approach to help a state understand the large and small consumers within the state and helps target sectors for policy interventions. It also employs a bottom-up approach to explore a sector- or technology specific clean energy policy.</p> <p>This analysis was performed in 2007 by breaking down consumption data by the sectors that consume the fuels, including the commercial, residential, industrial, transportation, and utility sectors. Consumption and/or generation-related baseline data can be obtained from DOE's EIA, EPA's eGRID, NERC, IOSs, public utility commissions, and many more.</p>	Wisconsin Office of Energy Independence. 2007. Wisconsin Energy Statistics.	<ul style="list-style-type: none"> Overall petroleum use decreased 2.3% in 2009. Of the total petroleum used in Wisconsin, 81.4 percent is in the transportation sector, which saw a decrease of 4.2%. 	<p>From 2008-2009</p> <ul style="list-style-type: none"> Utility SO₂ emissions decreased 18.9 percent Utility NO_x emissions decreased 28.2 percent 	<ul style="list-style-type: none"> Total electricity sales decreased 6.4% in 2009 but have grown 3.7% over the past ten years. In 2009, electricity sales decreased in all sectors. 	1970–2006	R

* P = Prospective; R= Retrospective

Chapter 3: Assessing the Electric System Benefits of Clean Energy Programs

Case Studies			Key Benefits Findings, Results and Activities				
State/Region and Name of Program	Summary of Policy/Program and Analysis	Link	Energy	Emissions, Air Quality, and Health	Economic	Time Period for Analysis	Type of Analysis*
California: Utilities' Energy Efficiency Programs	<p>The California Public Utilities Commission (CPUC) approved a new method for calculating avoided costs for use in evaluating utility energy efficiency programs in California and demonstrated how clean energy can be used in the state energy planning and policy decision-making process.</p> <p>A new methodology was used that includes five major categories of costs that are avoided when demand is reduced through installation of energy efficiency resources. It produces time- and location-specific cost estimates, whereas the previous avoided-cost methodology relied more upon average statewide values.</p>	Energy Efficiency Portfolio Plans and Program Funding Levels for 2006-2008—Phase 1 Issues. California Public Utilities Commission. Interim Opinion. September 22, 2005.	<ul style="list-style-type: none"> The electricity growth rate for all sectors from 2005-2020 is projected to be 1.52% 		<p>Avoided electricity generation costs:</p> <ul style="list-style-type: none"> \$133/MWh with the new method (compared with \$80/MWh with the old method) <p>Avoided T&D costs:</p> <ul style="list-style-type: none"> Avoided environmental externality costs Avoided ancillary services costs Reduced wholesale market clearing prices 	2006–2008	P
Massachusetts: Energy Efficiency and Distributed Generation	<p>This study explores the potential price and emissions benefits of increasing distributed generation, photovoltaics (PV), combined heat and power (CHP) and energy efficiency in Massachusetts through 2020.</p> <p>A reference case was developed to determine what the wholesale electric prices and carbon dioxide emissions would be without the additional clean energy resources. PROSYM simulation model was used to determine the potential price and emissions impacts of the four scenarios which are then compared against the reference case to determine the impacts.</p>	Impacts of Distributed Generation on Wholesale Electric Prices and Air Emissions in Massachusetts. Synapse Energy Economics, March 31, 2008.		<ul style="list-style-type: none"> Each scenario was found to achieve reductions of CO₂ emissions relative to the reference case: EE and CHP combined will have a reduction of 2.4 million short tons CO₂/year in 2020 	<ul style="list-style-type: none"> The 250MW of PV is expected to displace 356 GW of purchases from the wholesale market and reduce prices by 0.4% EE is expected to reduce prices by 1.6% EE and CHP would produce 5.1% reduction 	2007–2020	P

* P = Prospective; R= Retrospective

Chapter 3: Assessing the Electric System Benefits of Clean Energy Programs

Case Studies			Key Benefits Findings, Results and Activities				
State/Region and Name of Program	Summary of Policy/Program and Analysis	Link	Energy	Emissions, Air Quality, and Health	Economic	Time Period for Analysis	Type of Analysis*
Northeast: Price Effects of Demand Response	In all four of the structured, RTO-run eastern spot electricity markets, historically high peak load values occurred during a week-long heat wave in August 2006. Market coordinators all acknowledged the role that demand response (DR) played in keeping peak load lower than what otherwise would have occurred and the study estimate the wholesale price effects from using DR during these peak times.	"Early Aug. Demand Response Produces \$650 Million Savings in PJM: Reducing Electricity Use Stretches Power Supplies, Lowers Wholesale Electricity Supplies." August 17, 2006.			<ul style="list-style-type: none"> Wholesale prices would have been \$300/MWh higher without demand response during heat wave Demand response to heat wave reported savings of about \$650 million for energy purchasers 	2006	R
Vermont: System Planning Approach to Estimate Avoided Transmission Costs	<p>Vermont: System Planning Approach to Estimate Avoided Transmission Costs The Vermont Electric Company (VELCO) undertook a study in 2003 of alternatives to a proposed major upgrade in the northwest corner of Vermont. VELCO conducted a thorough study of distributed generation, energy efficiency, and new central generation as alternatives to the upgrade. It demonstrates one way to use the system planning approach to estimate avoided transmission costs.</p> <p>The study identified a range of central generation and distributed generation options and estimated their costs. In addition, a location-specific study of the available energy efficiency potential and the program costs for delivering that potential was prepared. Various combinations of energy efficiency and generation were assembled as alternatives to the proposed transmission project and compared based on total present value of cost of service.</p>	LaCapra Associates, 2003. Alternatives To Velco's Northwest Vermont Reliability Project. January 29 (LaCapra Associates, 2003; Orans, 1989; Orans, 1992).			<ul style="list-style-type: none"> The study determined the cost of transmission upgrade and the cost of a smaller upgrade; the difference in those two costs could be used to assess the cost-effectiveness of the alternative resource package 	2002–2011	P

* P = Prospective; R = Retrospective

Chapter 4: Air Pollution, Greenhouse Gas, Air Quality & Health Benefits of Clean Energy Programs

Case Studies			Key Benefits Findings, Results and Activities				
State/Region and Name of Program	Summary of Policy/Program and Analysis	Link	Energy	Emissions, Air Quality, and Health	Economic	Time Period for Analysis	Type of Analysis*
Connecticut: Economic Impact of Oil and natural Gas Conservation and results of using COBRA	Connecticut worked with EPA and NESCAUM to quantify the economic, air quality, and health benefits of policy options while developing the state's 2005 Climate Change Action Plan. The state specifically analyzed the benefits of oil and natural gas conservation programs that encourage installation of EE equipment. Three scenarios analyzed from 2005-2020: oil program, gas program, combined programs. Program funded by a 3% natural gas and oil-use surcharge. Emissions were estimated through the development of their Climate Change Action Plan. Macroeconomic effects modeled with REMI. Public health effects from avoided emissions estimated with EPA's COBRA model.	Connecticut GSC on Climate Change. 2005. CCCAP. GSC on Climate Change. Connecticut Climate Change Web site. State Action Plan. CT GSC. 2004. 2005 Climate Change Action Plan, Appendix 9: Economic Impact of Oil and Natural Gas Conservation Policies. Connecticut Governor's Steering Committee, prepared by Regional Economic Models, Inc. November.		By 2020: <ul style="list-style-type: none"> Oil programs are expected to avoid: 1.89 millions of metric tons of carbon dioxide equivalent (MMT_{CO₂e}) Gas programs are expected to avoid: 2.07 MMT_{CO₂e}. 	Net benefits from 2005-2020 include (\$1996): <ul style="list-style-type: none"> 2,092 average annual jobs \$3.1M output \$2.03M GSP \$1.8M real disposable income An additional \$4 to \$1 payback of reduced health costs and public health benefits was identified as a result of reductions in criteria air pollutants. 	2005–2020	P

* P = Prospective; R= Retrospective

Chapter 4: Air Pollution, Greenhouse Gas, Air Quality & Health Benefits of Clean Energy Programs

Case Studies			Key Benefits Findings, Results and Activities				
State/Region and Name of Program	Summary of Policy/Program and Analysis	Link	Energy	Emissions, Air Quality, and Health	Economic	Time Period for Analysis	Type of Analysis*
<p>Minnesota: How BenMAP Has Been Used in Clean Energy Analysis: Minnesota Public Utilities Commission</p>	<p>For testimony to the Minnesota Public Utilities Commission about building a new clean energy electricity generating facility, Excelsior Energy compared the air quality and health effects of two proposed 600 MW integrated gasification and combined cycle (IGCC) units with two comparable supercritical pulverized coal (SCPC) units.</p> <p>The 2005 analysis used REMSAD to model Hg and PM air quality changes, and BenMAP to estimate and value the PM-related health effects. BenMAP systematically analyzes the health and economic benefits of air pollution control policy scenarios.</p>	<p>Excelsior Energy 2005. Air Quality and Health Benefits Modeling: Relative Benefits Derived from Operation of the MEP-I/II IGCC Power Station. December.</p>		<p>Installing IGCC technology would reduce annual emissions by:</p> <ul style="list-style-type: none"> • 2,600 tons of SO₂, • 600 tons of NO_x, and • 12 pounds of Hg. <p>In 2012, the IGCC units would avoid:</p> <ul style="list-style-type: none"> • 12 premature deaths nationally, • 20 heart attacks (infarctions), eight new cases of chronic bronchitis, and • 200,000 work loss days. <p>The study also quantified estimates of other health effects ranging from hospital admissions to asthma attacks.</p>	<ul style="list-style-type: none"> • The annual value of the one year of reduced health effects was estimated to be \$99 million nationally, with \$24 million occurring within Minnesota. 	2005–2012	P

* P = Prospective; R= Retrospective

Chapter 4: Air Pollution, Greenhouse Gas, Air Quality & Health Benefits of Clean Energy Programs

Case Studies			Key Benefits Findings, Results and Activities				
State/Region and Name of Program	Summary of Policy/Program and Analysis	Link	Energy	Emissions, Air Quality, and Health	Economic	Time Period for Analysis	Type of Analysis*
Texas: Energy Efficiency/ Renewable Energy Impact in the Texas Emissions Reduction Plan	<p>In 2001, the 77th Texas Legislature established the Texas Emissions Reduction Plan (TERP) with the enactment of Senate Bill 5, which required the Texas Commission on Environmental Quality (TCEQ) to promote EE/RE to meet ambient air quality standards and to develop a methodology for computing emission reductions for State Implementation Plans. To improve Texas air quality, TERP adopted the goal of implementing cost-effective EE/RE measures to reduce electric consumption by 5% per year for five years, beginning in 2002, using a variety of mandatory programs and voluntary financial incentive programs in non-attainment and affected counties.</p> <p>An analysis was performed with data from the TCEQ and EPA, including eGRID, to estimate the energy savings and NOX reductions from energy code compliance in new residential construction.</p>	Haberl et al 2007. Energy Efficiency/ Renewable Energy Impact in the Texas Emissions Reduction Plan (TERP): Volume 1 – Summary Report. Prepared for the Texas Commission on Environmental Quality (TCEQ). August, revised in December.	<p>Annual energy savings in 2006 amounted to:</p> <ul style="list-style-type: none"> • 498,582 MWh of electricity and • 576,680 BTUs of natural gas 	<p>NO_x emissions reduced by:</p> <ul style="list-style-type: none"> • 346 tons per year in 2004 • 361 tons per year in 2006 • 824 tons per year in 2007 • 1,416 tons per year in 2012 • 2,121 tons per year 2013 		2002–2013	R and P
Wisconsin: Focus on Energy Program	<p><i>Focus on Energy Public Benefits Evaluation – Semiannual Summary Report.</i> Prepared by PA Government Services for the Wisconsin DOA. September 27, 2006.</p>	Erickson et al. 2004. Erickson, J., C. Best, D. Sumi, B. Ward, B. Zent, and K. Hausker. Estimating Seasonal and Peak Environmental Emission Factors – Final Report. Prepared by PAGovernment Services for the Wisconsin DOA. May. Department of Administration. State of Wisconsin. 2005. Focus on Energy Public Benefits Evaluation – Semiannual Summary Report. Prepared by PAGovernment Services for the Wisconsin DOA. September.	<ul style="list-style-type: none"> • From 2001-2006, Wisconsin estimated that its programs saved 1 billion kWhs and nearly 50 million therms in annual energy consumption 	<p>These programs have displaced annual emissions from power plants and utility customers by:</p> <ul style="list-style-type: none"> • 5.8 million pounds of NO_x • 2.6 billion pounds of CO₂ • 11.4 million pounds of SO_x • 46 pounds of mercury 	<ul style="list-style-type: none"> • Add nearly \$1 billion in value to Wisconsin's gross state product 	2001–2011	R and P

* P = Prospective; R= Retrospective

Chapter 5: Economic Benefits of Clean Energy Programs

Case Studies			Key Benefits Findings, Results and Activities				
State/Region and Name of Program	Summary of Policy/Program and Analysis	Link	Energy	Emissions, Air Quality, and Health	Economic	Time Period for Analysis	Type of Analysis*
California: Economic, Energy, and Environmental Benefits of Concentrating Solar Power	This study analyzes benefits of concentrating solar power (CSP) for CA for two deployment scenarios: \$7B and \$13B invested (2100 MW and 4,000 MW) from 2008-2020. It emphasized in-state impact of employment created from manufacture, installation, and operation of CSP plants. CSP performance and cost analyzed with Excelergy. Displaced emissions estimated with emission factors from California Air Resources Board. Macroeconomic effects modeled with RIMS II.	Stoddard, L. J., Abiecunas, and R. O'Connell. 2006. Economic, Energy, and Environmental Benefits of Concentrating Solar Power in California. Prepared by Black & Veatch for U.S. DOE National Renewable Energy Laboratory. April.	<ul style="list-style-type: none"> • CSP scenarios avoid between 8%–18% of peak electricity demand growth by 2020 • 4000 MW of CSP avoid \$60M per year of natural gas costs in CA 	Each 100 MW of CSP avoids (per year): <ul style="list-style-type: none"> • 7.4 tons of NO_x emissions • 2.6 tons of VOCs • 191,000 tons of CO₂ 	<ul style="list-style-type: none"> • Each dollar spent on CSP yields direct and indirect impact of \$1.40 to GSP • Each 100 MW of CSP yields 94 permanent jobs 	2008–2020	P
Connecticut: Steps in a Macroeconomic Impact Analysis: Oil and Natural Gas Conservation Policies	In 2004, Connecticut analyzed the economic impact of oil and natural gas conservation policies in Connecticut. The state wanted to explore the impacts of fully funding a program between 2005 and 2020 to increase the efficiency of oil and natural gas for residential, commercial, and industrial users. Using the REMI Policy Insight model, their analysis showed economic benefits to the state from the increased investment in efficiency and that the natural gas conservation efforts contributed more than the oil programs to the overall benefits of the program. Note: the expected emissions benefits of these oil and gas policies is discussed above under the Chapter 4 case studies	REMI. 2004. Economic Impact of Oil and Natural Gas Conservation Policies. Prepared for U.S. Environmental Protection Agency and the State of Connecticut. November.			Benefits to the State <ul style="list-style-type: none"> • Employment (Average Annual Increase)*: 2,092 • Output (Mil '96\$): 3,094.90 • GSP(Mil '96\$): 2,033.01 • Real Disposable Personal Income (Mil '96\$): 1,749.42 • State Revenues (Mil '01\$): 382.13 *Employment is the average annual increase from the baseline. Employment is not cumulative and is based on output growth.	2005-2020	P

* P = Prospective; R= Retrospective

Chapter 5: Economic Benefits of Clean Energy Programs

Case Studies			Key Benefits Findings, Results and Activities				
State/Region and Name of Program	Summary of Policy/Program and Analysis	Link	Energy	Emissions, Air Quality, and Health	Economic	Time Period for Analysis	Type of Analysis*
<p>Georgia: Quantifying the Energy System Benefits of Clean Energy Policies</p>	<p>This study analyzes benefits of energy efficiency improvements from 2005-2015 for three investment scenarios: minimally, moderately, and very aggressive. Analysis included four main parts: collect GA energy profile data; estimate EE potential; estimate benefits; and review policy options to achieve EE potential.</p> <p>EE potential was modeled with ICF's EEPM. Direct energy cost savings were modeled with ICF's IPM. Macroeconomic effects modeled with Georgia Economic Modeling System (GEMS). Public health effects estimated with EPA's COBRA model.</p>	<p>Jensen, V., and E. Lounsbury. 2005. Assessment of Energy Efficiency Potential in Georgia. Prepared for the Georgia Environmental Facilities Authority by ICF Consulting. May.</p>	<ul style="list-style-type: none"> • Avoided generation in 2010 ranges from 1,207–4,749 GWh; • Regional wholesale electricity costs reduced by 0.5%–3.9% by 2015 • Reduce peak demand 1.7%–6.1% by 2015 	<p>All estimates versus 2010 baseline.</p> <ul style="list-style-type: none"> • CO₂ emission reduced 0.6%–2.4% • SO₂ emissions reduced 0.2%–1.3% • NO_x emissions reduced 0.3%–1.9% 	<ul style="list-style-type: none"> • 1.6 - 2.8 job impact per \$1M net benefit • Generate 1500 – 4200 net jobs by 2015 • Increase personal income \$48 - \$157M by 2015 	2005–2015	P
<p>Iowa: The Economic Impact of Energy Efficiency Programs and Renewable Power</p>	<p>This study examined the long-term economic development implications of energy efficiency (EE) programs, energy pricing/ cost changes, and renewable energy (RE) (biomass and wind power) from 1995-2015.</p> <p>Program cost and savings, including RE cost and productivity, estimated using program survey data. Macroeconomic effects (in terms of business output, personal income and employment) were modeled with REMI. Results were distinguished by year over a twenty-year period, and broken down by business type.</p>	<p>Weisbrod, G., K. Polenske, T. Lynch, and X. Lin. 1995. The Economic Impact of Energy Efficiency Programs and Renewable Power for Iowa: Final Report. Economic Development Research Group, Boston, MA. December.</p>	<ul style="list-style-type: none"> • From 2001-2006, Wisconsin estimated that its programs saved 1 billion kWhs and nearly 50 million therms in annual energy consumption 	<p>These programs have displaced annual emissions from power plants and utility customers by:</p> <ul style="list-style-type: none"> • 5.8 million pounds of NO_x • 2.6 billion pounds of CO₂ • 11.4 million pounds of SO_x • 46 pounds of mercury 	<p>REMI model forecasts indicate that, in Iowa over the 1995–2015 period, EE can lead to:</p> <ul style="list-style-type: none"> • 25 job-years for every \$1M invested • \$1.50 of disposable income for every \$1 invested <p>Biomass can lead to:</p> <ul style="list-style-type: none"> • 84 job-years per \$1M invested • \$1.45 disposable income per dollar invested <p>Wind can lead to:</p> <ul style="list-style-type: none"> • 2.5 job-years per \$1M invested 	1995–2015	R and P

* P = Prospective; R= Retrospective

Chapter 5: Economic Benefits of Clean Energy Programs

Case Studies			Key Benefits Findings, Results and Activities				
State/Region and Name of Program	Summary of Policy/Program and Analysis	Link	Energy	Emissions, Air Quality, and Health	Economic	Time Period for Analysis	Type of Analysis*
Illinois: The Economic and Environmental Impacts of Clean Energy Development	<p>This 2005 study analyzes benefits of Illinois <i>Sustainable Energy Plan</i>: RE supplying 8% of generation by 2012, 16% by 2020; Reduce load 16% by 2020 with EE; 1570 MW of CHP by 2020; 2000 MW of IGCC by 2020. Measures analyzed separately and collectively.</p> <p>Emission savings assume displacement coal-fired electricity, and estimated with emission factors and other EIA, EPA, DOE, and EPRI data. Macroeconomic effects modeled with ILREIM.</p>	Bournakis, A., G. Hewings, J. Cuttica, and S. Mueller. 2005. The Economic and Environmental Impacts of Clean Energy Development in Illinois. Submitted to the Illinois Department of Commerce and Economic Opportunity. June.		<p>By 2020, avoid:</p> <ul style="list-style-type: none"> • 0.4 million tons per year (mtpy) of SO_x • 0.2 mtpy of NO_x • 90.1 mtpy of CO₂ 	<p>The study estimated the plan by 2020 would directly lead to:</p> <ul style="list-style-type: none"> • \$7 billion net increase in economic output • \$1.5 billion net increase in personal income • 43,000 net new jobs <p>Combining direct and indirect benefits would achieve by 2020:</p> <ul style="list-style-type: none"> • \$18 billion net increase in economic output (2.12% increase) • \$5.5 billion net increase in personal income (1.83% increase) • 191,000 net new jobs (1.85% increase) 	2005–2020	P
Massachusetts: Summary of Economic Impacts of 2002 Massachusetts Energy Efficiency Program Activities	<p>The Massachusetts Division of Energy Resources (DOER) produces an annual report analyzing the impacts of ratepayer-based energy efficiency programs in the state. The 2004 report is a retrospective analysis, using the REMI Policy Insight model, of the macroeconomic effects of investments in energy efficiency (EE) made in 2002. DOER also used expenditure and savings data in combination with the Energy 2020 model to project the lifetime energy savings of the 2002 program activities.</p>	DOER. 2004. 2002 Energy Efficiency Activities. Massachusetts Division of Energy Resources.			<p>Electricity Bill Impacts</p> <p>Energy Savings</p> <ul style="list-style-type: none"> • Total Program Costs: \$138 million • Total Participant Energy Savings: <ul style="list-style-type: none"> – \$21.5 million (M)/year – Lifetime = \$249M • Average Cost for Conserved Energy: 4.0 ¢/kWh <p>Demand Savings</p> <ul style="list-style-type: none"> • Total Participant Demand Savings: \$1.2M/year <p>Systems Impacts</p> <ul style="list-style-type: none"> • Customer savings from Lower Wholesale Energy Clearing Prices: \$19.4 million <p>Economic Impacts</p> <ul style="list-style-type: none"> • Number of New Jobs Created in 2002: 2,093 • Disposable Income from Net Employment in 2002: \$79 million 	2002–2020	R and P

* P = Prospective; R= Retrospective

Chapter 5: Economic Benefits of Clean Energy Programs

Case Studies			Key Benefits Findings, Results and Activities				
State/Region and Name of Program	Summary of Policy/Program and Analysis	Link	Energy	Emissions, Air Quality, and Health	Economic	Time Period for Analysis	Type of Analysis*
National: Redirecting America's Energy: The Economic and Consumer Benefits of Clean Energy Policies	<p>A 2005 study analyzes benefits of two potential policies: national 20% RPS by 2020, and 20% RPS with reallocation of \$35 billion of fossil fuel and nuclear subsidies to EE and RE.</p> <p>This analysis used regional forecast data from EIA and other sources, along with IMPLAN to estimate macroeconomic effects.</p>	Nayak, N. 2005. Redirecting America's Energy: The Economic and Consumer Benefits of Clean Energy Policies. Prepared by the U.S. PIRG Education Fund. February.		<p>20% RPS with reallocation avoids by 2020 versus baseline::</p> <ul style="list-style-type: none"> • 634M tons of CO₂ • 1.9M tons of SO₂ • 0.8M tons of NO_x 	<p>20% RPS with reallocation achieves, by 2020:</p> <ul style="list-style-type: none"> • 154,589 net annual new jobs • \$6.8B net increase in wages • \$5.9B average annual net increase in GDP 	2005–2020	P
New Jersey: Clean Energy Program: 2005 Annual Report	<p>A 2005 NJ BPU report analyzes benefits of New Jersey's Clean Energy Program, which includes strategies to increase EE and RE. It analyzes annual and lifetime impact of measures installed in 2005. By 2008, program sought to have 6.5% of NJ electricity provided by RE. By 2012, the program seeks to have 785,000 MWh and 0.6 mcf of natural gas saved per year from EE.</p>	NJ BPU. 2005. New Jersey's Clean Energy Program: 2005 Annual Report. New Jersey Board of Public Utilities, Office of Clean Energy.	<p>From 2004 to 2005:</p> <ul style="list-style-type: none"> • electric energy savings and renewable energy generation grew by over 22% • natural gas savings grew by over 42% <p>Efficient equipment installed and practices put into effect in 2005 will continue to save energy for an average of 15 years. The 5-year program activities resulted in lifetime energy savings of:</p> <ul style="list-style-type: none"> • over 14 million MWh of electricity • 38 million Dekatherms of natural gas • 788,000 MWh of renewable generation. • The programs have also reduced electric demand by 450 MW. 	<p>Avoided emissions from 2005 activities, for 2005-2020:</p> <ul style="list-style-type: none"> • 13.2M tons of CO₂ • 46,317 tons of SO₂ • 21,813 tons of NO_x 	<p>From 2001–2006 new solar owners were estimated to have saved:</p> <ul style="list-style-type: none"> • \$1.1 million annually in total electricity costs 	2001–2020	R and P

* P = Prospective; R= Retrospective

Chapter 5: Economic Benefits of Clean Energy Programs

Case Studies			Key Benefits Findings, Results and Activities				
State/Region and Name of Program	Summary of Policy/Program and Analysis	Link	Energy	Emissions, Air Quality, and Health	Economic	Time Period for Analysis	Type of Analysis*
New York: Analyzing Macroeconomic Benefits of the Energy SmartSM Program	<p>The New York Energy Smart public benefits program, created in 1998, promotes energy efficiency across the commercial, industrial, and residential sectors; advances renewable energy; provides energy services to low income residents of New York; and conducts research and development. As part of a comprehensive evaluation process, NYSERDA produces an annual report detailing the multiple benefits of ESP on both a retrospective and prospective basis.</p> <p>NYSERDA used the REMI Policy Insight model, a macroeconomic model that combines elements of input-output, econometric, and computable general equilibrium models, to conduct the analysis. Outlay and energy savings estimated primarily using actual program data.</p>	<p>New York Energy Smart Program Evaluation and Status Report. NYSERDA. Report to the System Benefits Charge Advisory Group. May. 2006</p> <p>New York Energy Smart Program Evaluation and Status Report; Year Ending December 31, 2008. NYSERDA. Report to the Systems Benefit Charge Advisory Group. Final Report. March.</p>	<p>From 1999 – 2005:</p> <ul style="list-style-type: none"> • 1,040 MW reduction in peak demand <p>From 1999-2005:</p> <ul style="list-style-type: none"> • The number of energy service companies increased from fewer than 10 to over 180 companies 	<p>Actions to date avoid (per year):</p> <ul style="list-style-type: none"> • 1.4 million tons of CO₂ • 3,170 tons of SO₂ • 1,750 tons of NO_x 	<p>The model indicated the ESP initiatives from 1999-2008 have:</p> <ul style="list-style-type: none"> • Created over net 4,900 jobs • Increased personal income by \$293 million, • GSP by \$644 million • Total output by \$1 billion <p>Projecting to 2020, ESP is expected to create 86,400 net job years.</p> <p>From 2008-2017, actions to date yield (per year):</p> <ul style="list-style-type: none"> • Average of 4,100 jobs • \$182M labor income • \$244M output 	1999–2017	R and P
Nevada: Using REPP Labor Calculator: The Case of Nevada's RPS	<p>As part of its 1997 restructuring legislation, the Nevada legislature established an RPS that included a 5% renewable energy requirement in 2003 and a 15% requirement by 2013. The Nevada American Federation of Labor-Congress of Industrial Organizations (AFL-CIO) used the REPP Labor Calculator to estimate the job diversification effects of the RPS in 2005.</p>	<p>Nevada AFL-CIO. 2003. Comments Submitted to the Nevada Public Service Commission: Procedural Order No. 3 and Request for Comments No. 2. July.</p>	<ul style="list-style-type: none"> • 5% renewable energy requirement in 2003 • 15% requirement by 2013 		<p>From 2003-2013, the RPS would create:</p> <ul style="list-style-type: none"> • 27,229 total, direct FTE jobs • Of which, 19,138 are manufacturing jobs and • 8,092 would be installation, O&M jobs <p>*excludes indirect or induced effects</p>	2003–2013	P

* P = Prospective; R= Retrospective

Chapter 5: Economic Benefits of Clean Energy Programs

Case Studies			Key Benefits Findings, Results and Activities				
State/Region and Name of Program	Summary of Policy/Program and Analysis	Link	Energy	Emissions, Air Quality, and Health	Economic	Time Period for Analysis	Type of Analysis*
Oregon: Economic Impacts of Energy Tax Credit Programs: BETC/RETC	<p>The Oregon Department of Energy asked ECONorthwest to estimate the economic effects of the Business Energy Tax Credit (BETC) and Residential Energy Tax Credit (RETC) programs. These effects include impacts on employment, output, and wages as well as tax revenue in Oregon that resulted from 2006 tax credits and the subsequent spending on measures and labor that these credits create. ECONorthwest also isolated the economic impacts of energy efficiency improvements (i.e., energy savings) that were realized in 2006 in order to estimate the benefits to the economy that accumulate in future years.</p> <p>They used IMPLAN to model the macroeconomic effects.</p>	Grover, S. 2007. Economic Impacts of Oregon Energy Tax Credit Programs in 2006 (BETC/RETC). Prepared by ECONorthwest for the Oregon Department of Energy. May.	<ul style="list-style-type: none"> • Oregon commercial and residential energy costs decreased by \$46 million 		<p>The net impacts of the tax credits in Oregon for the year 2006 were an increase in:</p> <ul style="list-style-type: none"> • Gross state product of more than \$142 million • Jobs by 1,240 • Tax revenue of nearly \$10 million • Oregon wages by \$18.6 million <p>Continued energy savings support the following annual economic impacts in future years:</p> <ul style="list-style-type: none"> • Increase in Oregon's economic output by \$93 million • Continued net impact of 889 new jobs • Additional state and local tax revenues of \$10 million 	2006–2021	R and P
Southwest: The New Mother Lode: The Potential for More Efficient Electricity Use	<p>The Southwest Energy Efficiency Project (SWEET) analyzes benefits from \$9B invested in EE in homes and businesses in the Southwest from 2003-2020 by comparing a BAU scenario to a "High Efficiency" scenario. "High efficiency" assumes widespread adoption of cost-effective, commercially available EE measures that would reduce electricity consumption by 18% by 2010 and 33% by 2020.</p> <p>Residential and commercial cost-effective energy savings modeled with DOE-2.2. Industrial cost-effective energy savings potential modeled with LIEF. Energy cost savings and avoided emissions modeled with NEMS. Macroeconomic effects modeled with IMPLAN.</p>	SWEET. 2002. The New Mother Lode: The Potential for More Efficient Electricity Use in the Southwest. Southwest Energy Efficiency Project. Report for the Hewlett Foundation Energy Series. November.	<p>By 2020:</p> <ul style="list-style-type: none"> • Avoids \$10.6B capacity investment (thirty-five 500 MW plants) • Avoids \$25B electricity supply costs per year by 2020 • Avoids \$2.4B end-use natural gas cost per year by 2020 	<p>By 2020:</p> <ul style="list-style-type: none"> • Reduces CO₂ emissions by 26% • Reduces SO₂ emissions by 4% • Reduces NO_x emissions by 5% 	<ul style="list-style-type: none"> • Increase regional employment by 0.45% (58,400) FTE jobs per year versus 2020 baseline • Increase salary income by \$1.34B per year versus 2020 baseline 	2003–2020	P

* P = Prospective; R= Retrospective

Chapter 5: Economic Benefits of Clean Energy Programs

Case Studies			Key Benefits Findings, Results and Activities				
State/Region and Name of Program	Summary of Policy/Program and Analysis	Link	Energy	Emissions, Air Quality, and Health	Economic	Time Period for Analysis	Type of Analysis*
Utah: Using JEDI: The Case of Wind Power in Utah County	Wind power has been proposed in Utah as a way to diversify the state's electricity generation. In 2006 Utah State University used JEDI to inform decision makers about the likely impact of five wind capacity scenarios: 5 MW, 10 MW, 14.7 MW, 20 MW, and 25 MW. This report quantifies the potential economic opportunities created by wind development, including projections for the 14.7-MW project in Spanish Fork Canyon, for Utah County. It uses economic and demographic information from three sources: (1) the Economic Development Corporation of Utah (EDCU); (2) IMPLAN multipliers for Utah county supplied by NREL; and (3) two local wind developers.	Mongha, N., E. Stafford, and C. Hartman. 2006. An Analysis of the Economic Impact on Utah County, Utah from the Development of Wind Power Plants. Renewable Energy for Rural Economic Development. Utah State University. DOE/GO-102006-2316. May.			<p>If the Spanish Fork project (14.7 MW) were built it would produce (using 2005 dollar values):</p> <ul style="list-style-type: none"> • 46 total new jobs • \$1.2 million in wage earnings • \$4.2 million in economic output during the construction phase of the project 	Not specified	P
Wisconsin: Focus on Energy Program	Wisconsin's Focus on Energy Program advances cost effective energy efficiency and renewable energy projects in the state through information, training, energy audits, assistance and financial incentives. The Wisconsin Department of Administration conducted an evaluation of the economic impacts of the Focus on Energy Program from its inception in 2002 through 2026. The analysis involved documentation and extrapolation of the net direct effects of the program; application of a regional economic model; and analysis of the implications. The results indicate that the Focus on Energy Program provides net benefits to the State of Wisconsin.	Wisconsin Department of Administration. 2007. Division of Energy. Focus on Energy Public Benefits Evaluation. Economic Development Benefits: FY07. Economic Impacts Report. Final: February 23, 2007.			<p>Between 2002 and 2026, the Focus on Energy Program is expected to:</p> <ul style="list-style-type: none"> • create more than 60,000 job-years; • generate sales for Wisconsin businesses of more than eight billion dollars; • increase value added or gross state product by more than five billion dollars; • increase disposable income for residents by more than four billion dollars. 	2002 - 2026	

* P = Prospective; R= Retrospective

Additional Studies and Programs that Highlight the Benefits of Clean Energy

Case Studies			Key Benefits Findings, Results and Activities				
State/Region and Name of Program	Summary of Policy/Program and Analysis	Link	Energy	Emissions, Air Quality, and Health	Economic	Time Period for Analysis	Type of Analysis*
California: The Economics of Solar Power	The Million Solar Roofs initiative seeks to install 3000 MW of solar on CA roofs by the end of 2016. This analysis covers retrofit and new construction applications between 2007-2016 and estimates the multiple benefits of the initiative. Infrastructure and emission savings based on E3 Avoided Cost model. Primary analysis was performed with Million Solar Systems Model, based on solar market data from CEC and CPUC.	Cinnamon, B., T. Beach, M. Huskins, and M. McClintock. 2005. The Economics of Solar Power for California. White Paper. August.	<ul style="list-style-type: none"> Avoid \$7.1M capacity infrastructure costs (3,000 MW of peak capacity) 	<ul style="list-style-type: none"> Avoid \$5,526M in emission costs, including NO_x and CO₂ 	<ul style="list-style-type: none"> Additional \$0.50 economic activity in CA per \$1 invested 40 FTE jobs in CA per MW 	2007–2016	P
Massachusetts: The Public Benefit of Energy Efficiency to the State of Massachusetts	This study analyzes retrospectively the benefits of EE in MA from 1977-1997 and projects future benefits through 2015. Study does not establish a link between actual government EE programs and changes in EE. It uses an econometric model. Changes in energy intensity used to approximate efficiency changes by controlling for sector composition, energy prices, new capital, and climate.	Bernstein, M., R. Lempert, D. Loughram, and D. Ortiz. 2002a. The Public Benefit of Energy Efficiency to the State of Massachusetts. Prepared by RAND Science and Technology.		In 1997, past energy efficiency actions resulted in a reduction of: <ul style="list-style-type: none"> 2.0M tons of CO₂ 11,000 tons of SO₂ 4,000 tons of NO_x (Versus 1997 baseline)	<ul style="list-style-type: none"> From 1977-1997 EE produced \$1,644 - \$2,562 in per capita GSP \$323 - \$2,322 additional per capita gains by 2015 	1977–1997; and through 2015	R and P
Midwest: Job Jolt: The Economic Impacts of Repowering the Midwest: The Clean Energy Development Plan for the Heartland	This study analyzes benefits of implementing the <i>Repowering the Midwest Clean Energy Development Plan</i> for a 10-state region in the Midwest that includes reducing electricity demand by 28% by 2020 with EE, and diversifying towards RE and CHP generation over a 20-year period. The analysis is performed with Census and other data, and econometric I-O models developed by REAL at the University of Illinois.	Hewings and Yanai. 2002. Job Jolt: The Economic Impacts of Repowering the Midwest: The Clean Energy Development Plan for the Heartland.			By 2020: <ul style="list-style-type: none"> Over 200,000 net new jobs \$19.4B increase in regional economic output 	2002–2020	P
National: 2002 Energy Efficiency Activities: A Report by the Division of Energy Resources	This study analyzes benefits of \$138 million of ratepayer-based EE investments during 2002 and cumulative EE investments from 1998-2002. It analyzes annual and lifetime benefits to participants and all consumers. The energy cost savings, energy system benefits and emission savings estimated with actual program data, ISO-NE data, other data, DOE's Energy 2020, and a bid-stack model. Macroeconomic effects are modeled with REMI.	Commonwealth of Massachusetts Office of Consumer Affairs and Business Regulation. 2004. 2002 Energy Efficiency Activities: A Report by the Division of Energy Resources. Summer.	<ul style="list-style-type: none"> \$19.4M savings from 1998-2002 (\$5.9M for 2002 only) due to lower wholesale electricity prices 0.5% (48 MW) peak demand reduction in 2002. 	2002 emission reductions: <ul style="list-style-type: none"> 394 tons SO₂ 135 tons NO_x 161,205 tons CO₂; Lifetime effect of 2002 actions: <ul style="list-style-type: none"> 5,516 tons SO₂ 1,890 tons NO_x 2,256,870 tons CO₂ 	In 2002: <ul style="list-style-type: none"> 1,778 new jobs \$139M in GSP \$79M disposable income Lifetime effect of 2002 actions: <ul style="list-style-type: none"> 315 permanent jobs, \$22M GSP \$15M in income 	1998–2002	R

* P = Prospective; R= Retrospective

Additional Studies and Programs that Highlight the Benefits of Clean Energy

Case Studies			Key Benefits Findings, Results and Activities				
State/Region and Name of Program	Summary of Policy/Program and Analysis	Link	Energy	Emissions, Air Quality, and Health	Economic	Time Period for Analysis	Type of Analysis*
National: The Work that Goes Into Renewable Energy	This study analyzes labor requirements for renewable energy deployment in the United States. Labor estimates from construction, installation, and O&M only account for direct effects – indirect multiplier effects no examined. The study is not specific to any particular state and used survey information, not a model. Authors collected primary employment data from companies in the RE and coal sectors. It accounts for jobs in manufacturing, transport, delivery, construction, installation, and O&M and includes a comparison with coal power.	Singh and Fehrs. 2001. The Work that Goes Into Renewable Energy. November.			Job effects: <ul style="list-style-type: none"> • 35.5 person-years per MW of solar • 4.8 person-years per MW of wind • 3.8-21.8 person-years per MW of biomass co-firing • 5.7 person-years per \$1M solar or wind cost over 10 years 	2001	R
National: Ancillary Benefits of Reduced Air Pollution in the United States from Moderate Greenhouse Gas Mitigation Policies in the Electric Sector	This study analyzes benefits of GHG and criteria pollutant mitigation, including the value of health impacts from air quality changes. It analyzes various carbon-tax scenarios from 2000-2010. The analysis used the Haiku electricity model to simulate effects on retirement and system dispatch. Emission changes were translated into health effects with damage functions and the TAF atmospheric transport model. Concentration-Response functions were used to estimate health endpoints.	Burtraw et al. 2001. Ancillary Benefits of Reduced Air Pollution in the United States from Moderate Greenhouse Gas Mitigation Policies in the Electric Sector. December.		<ul style="list-style-type: none"> • NO_x related health benefits in 2010 range from \$315 - \$408M • NO_x related health benefits per ton of carbon emissions reduced, range from \$7.5 - \$13.2 dollars 		2000–2010	P
New England: Electric Energy Efficiency and Renewable Energy: An Assessment of Existing Policies and Prospects for the Future	This study analyzes benefits of EE and RE in New England from Public Benefits Funds and RPS programs. It assumes that current policies change only as planned, through 2010, and does not cover unplanned scenarios. Authors used actual and estimated data on program expenditures and savings. Air quality and emission benefits were estimated with OTC's Emission Reduction Workbook and macroeconomic effects were modeled with IMPLAN.	Sedano et al. 2005. Electric Energy Efficiency and Renewable Energy: An Assessment of Existing Policies and Prospects for the Future. May.	<ul style="list-style-type: none"> • In 2004, EE reduced peak demand by 1,421 MW 	From 2000 – 2010, avoid: <ul style="list-style-type: none"> • 31.7M tons (6%) of CO₂ • 34,200 tons of SO₂ • 22,039 tons of NO_x 	From 2000 – 2010, net increase of: <ul style="list-style-type: none"> • \$6.1B economic output • \$1.04M wage income • 28,190 job years 	2005–2010	P
Pennsylvania: Economic Impact of Renewable Energy	This study analyzes benefits of implementing a 10% RPS in PA over the period 2006-2025, which would require \$4.68 billion direct investment. A statewide renewable energy supply curve was created to determine the least-cost portfolio. Authors used a simple linear model with publicly available data, and the BEA's RIMS II model to estimate macroeconomic effects.	Pletka, R. 2004. Economic Impact of Renewable Energy in Pennsylvania. Prepared by Black & Veatch for The Heinz Endowments and Community Foundation for the Alleghenies. March.			Over 2006-2015 period: <ul style="list-style-type: none"> • Increase output \$10.1B • Increase earnings \$2.8B • Create 85,000 jobs 	2006–2025	P

* P = Prospective; R= Retrospective

Additional Studies and Programs that Highlight the Benefits of Clean Energy

Case Studies			Key Benefits Findings, Results and Activities				
State/Region and Name of Program	Summary of Policy/Program and Analysis	Link	Energy	Emissions, Air Quality, and Health	Economic	Time Period for Analysis	Type of Analysis*
Texas: Increasing the Renewable Energy Standard: Economic and Employment Benefits	<p>This study analyzes benefits of increasing Texas' current RPS (requiring 2.7% of sales from new renewable energy by 2009) to a requirement of 20% renewable energy by 2020. It also analyzes a more modest increase to about 8% renewable energy by 2025.</p> <p>Impacts on electricity and natural gas prices and consumer energy bills were examined using the Department of Energy's National Energy Modeling System (NEMS) model. Macroeconomic impacts were quantified using IMPLAN. Expenditure breakdown and local share data for wind projects were based on NREL's Jobs and Economic Development Impacts (JEDI) model</p>	Deyette and Clemmer. 2005. Increasing the Renewable Energy Standard: Economic and Employment Benefits.	<p>By 2025, the 20% RPS achieves:</p> <ul style="list-style-type: none"> • 9% reduction in average electricity prices • 3% reduction in natural gas prices • Residential solar heating systems that offset 390 MW of peak capacity 	<p>By 2025, the 20% RPS avoids:</p> <ul style="list-style-type: none"> • 20 million metric tons of CO₂ emissions 	<p>By 2020, the 20% RPS achieves:</p> <ul style="list-style-type: none"> • \$950M additional income • \$440M increase in GSP • 24,650 net new jobs (2.8 times more jobs than with fossil fuels) 	2005–2025	P
Washington: The Washington Clean Energy Initiative: Effects of I-937 on Consumers, Jobs and the Economy	<p>This study analyzes the benefits of an RPS that would support 1,300 average megawatts (avgMW) of renewable sources by 2025, along with 1,000 avgMW of cost-effective energy efficiency from 2010–2025. The analysis compares the clean energy initiative with a reference case in which no further energy efficiency and renewable energy investments are made after 2009.</p> <p>Effects on electricity rates, total resource costs, and consumer electricity bills were examined using a spreadsheet model. Macroeconomic impacts were analyzed using IMPLAN. Expenditure breakdown data for construction, O&M of renewable plants was based on a variety of sources, including state and federal agencies, renewable developers, utilities, and NREL's Jobs and Economic Development Impacts (JEDI) model.</p>	Deyette and Clemmer. 2006. The Washington Clean Energy Initiative: Effects of I-937 on Consumers, Jobs and the Economy.	<p>The set of efficiency measures developed under the initiative achieve:</p> <ul style="list-style-type: none"> • An average savings of \$0.54 cents/kWh due to avoided T&D • Avoided construction of six natural gas power plants, operating at an average capacity of 165 MW each. 	<p>By 2025, the initiative avoids:</p> <ul style="list-style-type: none"> • 4.6 million metric tons of CO₂ emissions 	<p>By 2025, the initiative achieves:</p> <ul style="list-style-type: none"> • \$138M additional income • \$148M increase in GSP • \$30M in income to rural landowners • 1,230 net new jobs in the year 2025 (2.6 times more jobs than would be created using fossil fuels) 	2010–2025	P

* P = Prospective; R= Retrospective

This page is intentionally left blank.

APPENDIX B

Tools and Models Referenced in Each Chapter

DOCUMENT MAP

- CHAPTER ONE
Introduction
- CHAPTER TWO
Potential Energy Impacts of Clean Energy
- CHAPTER THREE
Electric System Benefits of Clean Energy
- CHAPTER FOUR
Air Quality Benefits of Clean Energy
- CHAPTER FIVE
Economic Benefits of Clean Energy
- APPENDIX A
Catalogue of Clean Energy Case Studies
- **APPENDIX B**
Tools and Models Referenced in Each Chapter

TOOLS AND MODELS REFERENCED IN CHAPTER 2

EXAMPLES OF AVAILABLE TOOLS FOR ESTIMATING DIRECT ENERGY IMPACTS

Internet-Based Methods:

- eCalc
WEB SITE: <http://ecalc.tamu.edu/>
- EPA Energy Savings Calculators
WEB SITE: <http://www.energystar.gov/purchasing>
- ENERGY STAR Roofing Comparison Calculator
WEB SITE: <http://www.roofcalc.com/default.aspx>
- ENERGY STAR Target Finder
WEB SITE: http://www.energystar.gov/index.cfm?c=new_bldg_design.bus_target_finder
- ENERGY STAR Portfolio Manager
WEB SITE: <https://www.energystar.gov/benchmark>
- PVWatts
WEB SITE: http://rredc.nrel.gov/solar/codes_algs/PVWATTS/version1/

Spreadsheet-Based Methods:

- EMD International WindPro
WEB SITE: <http://www.emd.dk/WindPRO/Introduction/>
- RETScreen Clean Energy Project Analysis Software
WEB SITE: <http://www.retscreen.net/ang/home.php>
- Integral Analytics: DSMore
WEB SITE: <http://www.integralanalytics.com/dsmore.php>

Software Methods:

- fChart and PV-fChart
WEB SITE: <http://www.fchart.com/index.shtml>
- EQuest
WEB SITE: <http://www.doe2.com/equest/>
- ENERGY-10™
WEB SITE: <http://www.nrel.gov/buildings/energy10.html>

- DOE-2
WEB SITE: <http://doe2.com/DOE2/index.html>

EXAMPLES OF SOPHISTICATED SUPPLY FORECASTING MODELS

Electricity Dispatch:

- PROSYM
WEB SITE: <http://www1.ventyx.com/analytics/market-analytics.asp>
- GE-MAPS
WEB SITE: http://www.gepower.com/prod_serv/products/utility_software/en/ge_maps/index.htm
- PROMOD
WEB SITE: <http://www.ventyx.com/analytics/promod.asp>
- MIDAS
WEB SITE: <http://www.ventyx.com/advisory/horizons-interactive.asp>

Capacity Expansion or Planning:

- NEMS
WEB SITE: <http://www.eia.doe.gov/oiaf/aeo/overview/index.html>
- IPM®
WEB SITE: <http://www.icfi.com/Markets/Energy/energy-modeling.asp#2>
- ENERGY 2020
WEB SITE: <http://www.energy2020.com/>
- Long range Energy Alternatives Planning System (LEAP)
WEB SITE: <http://www.energycommunity.org/default.asp?action=47>
- Strategist
WEB SITE: <http://www1.ventyx.com/analytics/strategist.asp>
- Plexos
WEB SITE: <http://www.energyexemplar.com/>

- EGEAS

WEB SITE: <http://my.epri.com/portal/server.pt?space=CommunityPage&cached=true&parentname=ObjMgr&parentid=2&control=SetCommunity&CommunityID=221&PageIDqueryComId=0>

- AURORAxmp

WEB SITE: http://www.epis.com/aurora_xmp/

- MARKAL-MACRO

WEB SITE: <http://www.etsap.org/Tools/MARKAL.htm>.

- Ventyx System Optimizer

WEB SITE: <http://www.ventyx.com/analytics/system-optimizer.asp>

TOOLS AND MODELS REFERENCED IN CHAPTER 3

DISPATCH MODELS AVAILABLE FOR STATES

- EnerPrise Market Analytics (powered by PRO-SYM) supported by Ventyx.

WEB SITE: <http://www1.ventyx.com/analytics/market-analytics.asp>

- Multi-Area Production Simulation (MAPS™) developed and supported by GE Energy and supported by other contractors.

WEB SITE: http://www.gepower.com/prod_serv/products/utility_software/en/ge_maps/index.htm

- Plexos for Power Systems owned by Energy Exemplar.

WEB SITE: (<http://www.energyexemplar.com>)

- PowerBase Suite™ (including PROMOD IV®) supported by Ventyx.

WEB SITE: <http://www1.ventyx.com/analytics/promod.asp>

ELECTRIC SECTOR-ONLY CAPACITY EXPANSION MODELS

- IPM® developed and supported by ICF International.

WEB SITES:

<http://www.icfi.com/Markets/Energy/energy-modeling.asp#2>

http://www.icfi.com/markets/energy/doc_files/ipmglobal.pdf

- PowerBase Suite™ (including Strategist®) supported by Ventyx.

WEB SITE: <http://www1.ventyx.com/analytics/strategist.asp>

WHOLE ENERGY–ECONOMY SYSTEM PLANNING MODELS

Energy system-wide models with electricity sector capacity expansion:

- U.S. DOE National Energy Modeling System (NEMS)

WEB SITE: <http://www.eia.doe.gov/oiaf/aeo/overview/>

- MARKet ALlocation (MARKAL) Model
WEB SITE: <http://www.etsap.org/markal/main.html>

- Energy 2020
WEB SITE: <http://www.energy2020.com/>

Specialized proprietary models of the T&D system's operation:

- PowerWorld Corporation's power systems simulation package
WEB SITE: <http://www.powerworld.com/>
- Siemens (PSS®E) probabilistic analyses and dynamics modeling
WEB SITE: https://www.energy.siemens.com/cms/00000031/en/ueberuns/organizati/services/siemenspti/softwareso/Pages/psse_1439533.aspx

TOOLS AND MODELS REFERENCED IN CHAPTER 4

TOOLS TO HELP STATE AND LOCAL GOVERNMENTS DEVELOP GHG AND CRITERIA AIR POLLUTANT EMISSION INVENTORIES

- EPA's State Inventory Tool (SIT)
WEB SITE: http://www.epa.gov/climatechange/emissions/state_guidance.html
- Clean Air and Climate Protection Software Tool (CACPS)
WEB SITE: <http://www.cacpsoftware.org/>

TOOLS STATES CAN USE TO HELP DEVELOP BOTTOM-UP GHG AND CRITERIA AIR POLLUTANT INVENTORIES

For GHG inventories:

- Portfolio Manager
WEB SITE: http://www.energystar.gov/index.cfm?c=evaluate_performance.bus_portfoliomanager_carbon

For criteria air pollutant inventories:

- Point Sources: Landfill Gas Emissions Model
WEB SITE: <http://www.epa.gov/ttn/catc/dir1/landgem-v302-guide.pdf>

Mobile sources:

- MOBILE6
WEB SITE: <http://www.epa.gov/OMS/m6.htm>
- NON ROAD 2005
WEB SITE: <http://www.epa.gov/oms/nonrdmdl.htm>
- Motor Vehicle Emission Simulator (MOVES)
WEB SITE: <http://www.epa.gov/otaq/models/moves/index.htm>

DATA SOURCES AND ADDITIONAL RESOURCES FOR TOP-DOWN AND BOTTOM-UP INVENTORIES

- National Emissions Inventory (NEI)
WEB SITE: <http://www.epa.gov/ttnchie1/trends/>

- eGRID

WEB SITE: <http://www.epa.gov/cleanenergy/energy-resources/egrid/index.html>

- Emissions Collection and Monitoring Plan System (ECMPS)

WEB SITE: <http://www.epa.gov/airmarkets/business/>

- WRI Climate Analysis Indicators Tool:

WEB SITE: <http://cait.wri.org/>

- State Agencies and Universities

- EPA State GHG Inventories

- Local GHG Inventories

TOOLS FOR FORECASTING FUTURE EMISSIONS

- EPA EIIIP Technical Report Series, Volume X: Emissions Projections.

WEB SITE: <http://www.epa.gov/ttn/chief/eiip/techreport/volume10/x01.pdf>

- EPA State GHG Projection Tool.

WEB SITE: <http://www.epa.gov/climatechange/wycd/stateandlocalgov/analyticaltools.html>

- The Clean Air and Climate Protection Software Tool.

WEB SITE: <http://www.cacpsoftware.org/>

BASIC AND SOPHISTICATED APPROACHES FOR QUANTIFYING AIR POLLUTANT AND GHG EMISSION EFFECTS OF CLEAN ENERGY INITIATIVES

Basic Approaches:

- eCalc

WEB SITE: <http://www.ecalc.com/calculator/scientific/>

- OTC Workbook

- CACPS

WEB SITE: <http://www.cacpsoftware.org/>

Sophisticated Approaches:

Electric Dispatch

- PROSYM

WEB SITE: <http://www.ventyx.com/analytics/market-analytics.asp>

- GE-MAPS

WEB SITE: http://www.gepower.com/prod_serv/products/utility_software/en/ge_maps/index.htm

- PROMOD

WEB SITE: <http://www.ventyx.com/analytics/promod.asp>

Capacity Expansion or Planning

- NEMS

WEB SITE: <http://www.eia.doe.gov/oiaf/aeo/overview/index.html>

- IPM*

WEB SITE: <http://www.icfi.com/Markets/Energy/energy-modeling.asp#2>

- ENERGY 2020

WEB SITE: <http://www.energy2020.com/>

- LEAP

TOOLS FOR QUANTIFYING AIR QUALITY AND/OR HEALTH IMPACTS

- SCRAM

WEB SITE: <http://www.epa.gov/ttn/scram/>

- REMSAD

WEB SITE: <http://remsad.saintl.com>

- CAMx

WEB SITE: <http://www.camx.com>

- UAM-V

WEB SITE: <http://uamv.saintl.com>

- CMAQ

WEB SITE: <http://www.epa.gov/AMD/CMAQ/CMAQscienceDoc.html>

- CALPUFF and AERMOD

WEB SITE: http://www.epa.gov/scram001/dispersion_prefrec.htm

- COBRA

WEB SITE: <http://epa.gov/statelocalclimate/resources/cobra.html>

- BenMAP

WEB SITE: <http://www.epa.gov/air/benmap/>

- ASAP

WEB SITE: <http://www.epa.gov/ttn/ecas/asap.html>

TOOLS AND MODELS REFERENCED IN CHAPTER 5

SCREENING TOOLS

- Job and Economic Development Impact (JEDI) Model for Wind Projects

WEB SITE: <http://www.energyfinder.org/>

- REPP Labor Calculator

WEB SITE: <http://www.repp.org/index.html>

- RMI Community Energy Opportunity Finder

WEB SITE: <http://www.energyfinder.org/>

MODELS FOR ESTIMATING MACROECONOMIC BENEFITS

- IMPLAN® input-output model (IMPLAN)

WEB SITE: <http://www.implan.com/>

- RAND

WEB SITE: <http://www.rand.org/>

- REMI Policy Insight model (REMI)

WEB SITE: <http://www.remi.com/>

- Berkeley Energy and Resources model (BEAR)