

CONCEPTUAL DESIGN  
of the  
BOOSTER APPLICATIONS FACILITY

BAF

October 1997

Brookhaven National Laboratory  
Associated Universities, Inc.  
Upton, Long Island, New York 11973

Prepared for the  
U.S. Department of Energy  
CONCEPTUAL DESIGN REPORT  
BOOSTER APPLICATIONS FACILITY  
CONCEPTUAL DESIGN REPORT  
Table of Contents

1.0	Introduction	
1.1	Project Overview .....	1
1.2	Work Breakdown Structure Summary .....	4
1.3	Cost Summary .....	6
1.4	Project Schedule .....	7
2.0	Description	
2.1	Conventional Construction .....	10
2.2	Tandem Modifications .....	12
2.3	Slow Extraction at the Booster .....	16
2.4	Spill Control .....	23
2.5	Modifications to the Booster .....	28
2.6	Beam Transport Design .....	32
2.7	Beam Transport Elements.....	38
2.8	Beam Transport Vacuum System.....	40
2.9	Power Supplies.....	44
2.10	Controls.....	48
2.11	Beam Instrumentation.....	50
2.12	Experimental Area Design.....	51
2.13	Shielding.....	57
2.14	Personnel Safety System.....	60
2.15	Services.....	64
2.16	Installation.....	65
3.0	Project Performance	
3.1	General.....	68
3.2	Project Schedule.....	68
4.0	Requirements and Assessments	
4.1	Environmental Protection.....	71
4.2	Security Requirements.....	72
4.3	Safety Evaluation.....	72
4.4	Quality Assurance.....	72
4.5	Environmental Evaluation.....	73
5.0	Project Cost Estimate	
5.1	Basis of Estimate.....	75
5.2	Cost Summary.....	76
5.3	Breakdown by WBS.....	77

## FIGURES

- 1.1.1 Accelerator Complex
- 1.2.1 Project Work Breakdown Structure
- 2.1.1 Site Plan
- 2.1.2 General Arrangement Plan
- 2.1.3 Support Building Plan
- 2.1.4 Typical Tunnel Cross Section
- 2.2.1 Tandem Modifications
- 2.3.1 Booster Modification for Slow Extracted Beam
- 2.3.2 AGS Booster Lattice Function
- 2.3.3a Phase Space at D6
- 2.3.3b Phase Space at D6
- 2.4.1 Servo for Spill Intensity Control in De-Bunched Mode
- 2.4.2 Servo System to Control Beam Spill Intensity in Bunched Mode
- 2.5.1 Thin Septum Magnet
- 2.5.2 Thick Septum Magnet
- 2.5.3 Installation of the thick Septum in D6 Straight Section
- 2.5.4 Installation of the thin Septum and IPM in D3 straight section
- 2.6.1 Beamline Magnet Locations
- 2.6.2 Optics of Beam Transport Line
- 2.6.3 Beam Envelope
- 2.6.4a Horizontal Beam Profile
- 2.6.4b Vertical Beam Profile at Target
- 2.6.5 Beam Spot at Target
- 2.7.1 Dipole Magnet
- 2.7.2 Quadrupole Magnets
- 2.7.3 Octupole Magnet
- 2.7.4 Low Field Corrector Magnet
- 2.8.1 Beamline Vacuum Equipment Locations
- 2.9.1 Typical Booster Magnet Cycles
- 3.2.1 Project Schedule



# INTRODUCTION

1

## 1.0 INTRODUCTION

### 1.1 Project Overview

This conceptual design describes a new experimental facility and accelerator modifications required to take advantage of heavy-ion beams from the Brookhaven AGS Booster accelerator for radiation effects studies of importance for the Space Program.

Radiation fields encountered in space may cause deleterious effects in humans, and these effects are of special concern for prolonged space missions beyond the protective terrestrial magnetosphere. Before such missions can be undertaken, a much more detailed understanding of these effects is required to allow planning and implementation of protective countermeasures.

Of particular concern are the radiation effects due to the heavy ion components of the galactic cosmic ray spectrum. Shielding of entire spacecraft against these very energetic and very penetrating particles is not practical and the expected dose rates are as high as 30 to 50 rad/year. There is great uncertainty regarding the risks associated with such high dose rates. The relative biological effectiveness (RBE) or the risk weighting of energetic heavy ions are not known, and there are even serious doubts about the validity of such concepts. At the very least it is thought that such factors can be very different for different organs and for different biological effects such as mutagenesis, carcinogenesis and cell necrosis. Many more studies with cells, tissue and animals are required to reach adequate estimates of radiation-associated risks to humans in space. Such studies can best be conducted under controlled, ground-based conditions by utilizing energetic ion beams from accelerators. Complementary studies are also being performed in space but these are much more difficult, complicated and expensive.

In addition to radiobiological studies, the effects of energetic heavy ions on microelectronic devices could also be investigated. The Brookhaven Tandem is currently the main facility for such studies at lower energies. Studies at higher, more realistic, energies are however of great importance to simulate effects such as multiple impacts of secondaries, and grazing incidence along the device plane. The importance of these studies is becoming more and more critical as continuing miniaturization leads to increasingly powerful but also increasingly vulnerable computers. Finally, the design and optimization

of local shielding configurations requires experimental verification and refinement of existing computer codes.

The Brookhaven AGS Booster is an ideal accelerator for these studies due to the good overlap between the available ion masses and energies with those encountered in space. With the closure of the BEVALAC facility at Lawrence Berkley National Laboratory (LBNL), Brookhaven is now the only laboratory in the USA where studies can be performed that require realistic simulation of the galactic cosmic ray environment. A variety of high-z-energy (HZE) particles will be available with energies ranging from a maximum of 1.3 GeV/amu for the lightest ions, to approximately 1.1 GeV/amu for iron and approximately 300 MeV/amu for gold, to a minimum of less than 100 MeV/amu.

The accelerator and beam transport modifications required for this project are all similar to prior developments carried out at Brookhaven. Heavy ions will originate in the Brookhaven MP-6 tandem accelerator which will be upgraded to make it a suitable injector for the BAF, and be transported to the Booster synchrotron for acceleration to the required energies. Currently, MP-7 is the Tandem used for Booster injection. Figure 1.1.1 is a schematic diagram of the accelerator complex at BNL, including existing and proposed facilities, and the beam lines connecting them.

Concurrent operation of the Booster for space radiation research and other kinds of research applications will be achieved by utilizing independent tandem injectors. The beam species and energy for both applications will be independent. Beams from either Tandem will be switched into the common injection line. At the Booster a new slow extraction system will be implemented which will require extensive accelerator modifications and rearrangements. A new beam line and tunnel enclosure will be built to transport the extracted beam to the experimental facility. Uniform beam intensities will be provided over areas ranging in size from about 1 cm to about 15 cm.

The experimental facility will be housed in a well shielded irradiation area and in a support building. Other existing on-site facilities, such as the Medical Department's extensive animal handling installations will also be utilized. Dosimetry and local access control will be provided through a local facility control room.

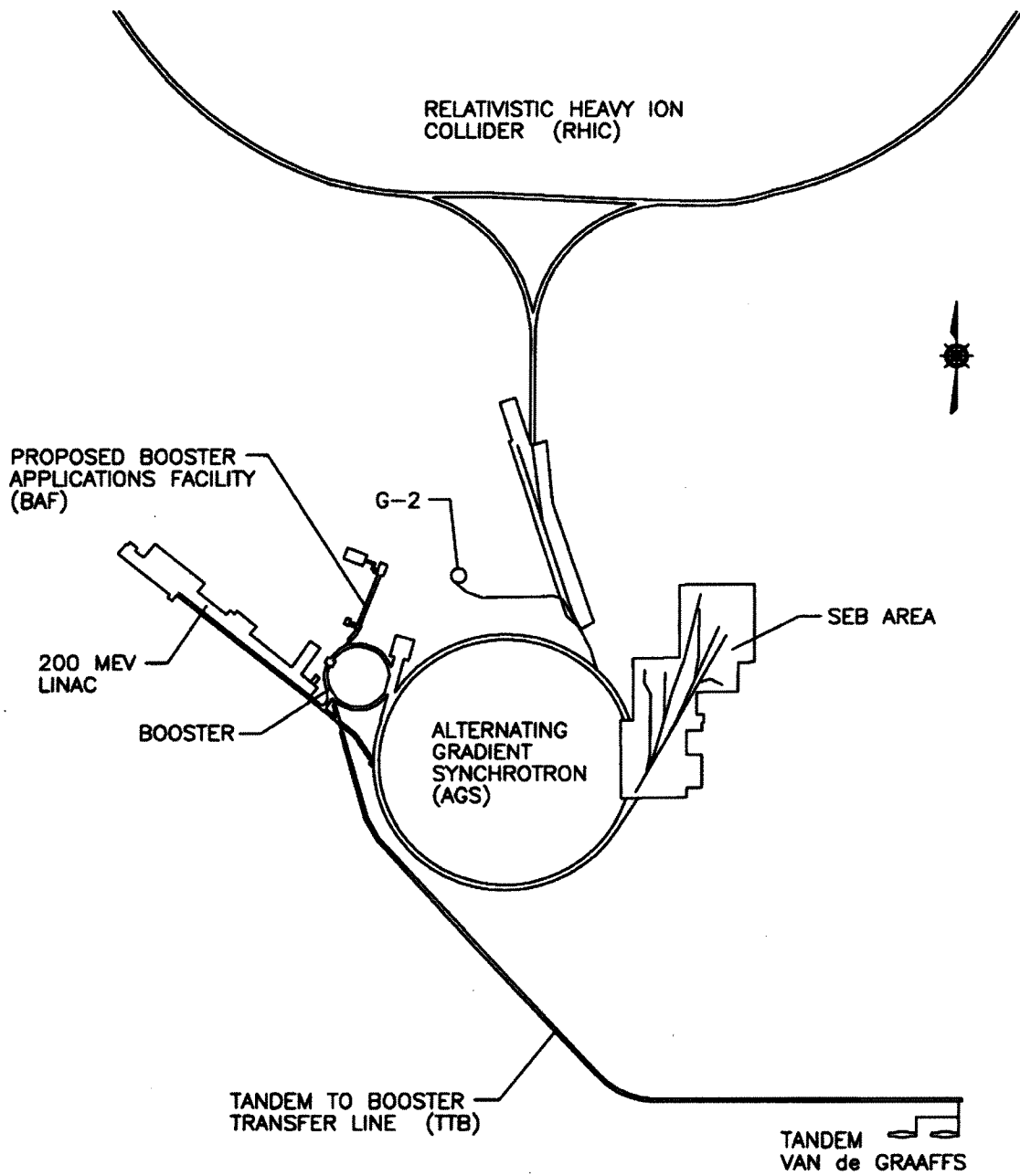

Figure 1.1.1 ACCELERATOR COMPLEX



The conventional facilities to be constructed for the Booster Application Facility will provide approximately 400 sq. ft. of experimental space and approximately 2,800 sq. ft. of support facilities. The experimental area building walls are composed of 4 ft. reinforced concrete. A labyrinth connects the experimental area with the laboratory support building. The target room is provided with a concrete beam stop imbedded in the back wall. The entire facility is shielded by 15 ft. of earth equivalent. The laboratory building will be a 70 ft. x 40 ft. metal building. The laboratory building contains five support laboratories, including temporary biological specimen holding and preparation areas, as well as laboratories for work with cell cultures and tissues. Also included are a beam control room, a mechanical service equipment area and rooms for radioactive storage and miscellaneous items. Power supplies for the beam transport magnets and various other equipment will be located in a 2,000 sq. ft. power supply building, a pre-engineered steel frame construction.

## 1.2 Work Breakdown Structure (WBS) Summary

As seen in Figure 1.2.1, the project WBS, Booster Applications Facility (BAF) is divided into eight (8) level-two categories. These items are further divided into supporting WBS elements.

### WBS 1.1 Conventional Construction

Conventional Construction includes all shielded tunnel and concrete experimental areas. A laboratory support building and power supply structures are included.

### WBS 1.2 Booster Modifications

Slow extraction includes rearrangement of existing apparatus and new components in the Booster in order to deliver an external slow extracted beam to the Applications Facility.

### WBS 1.3 Beam Transport System

Beam transport includes the system designed to deliver a beam to the experimental area.

# Booster Applications Facility Work Breakdown Structure Level 3

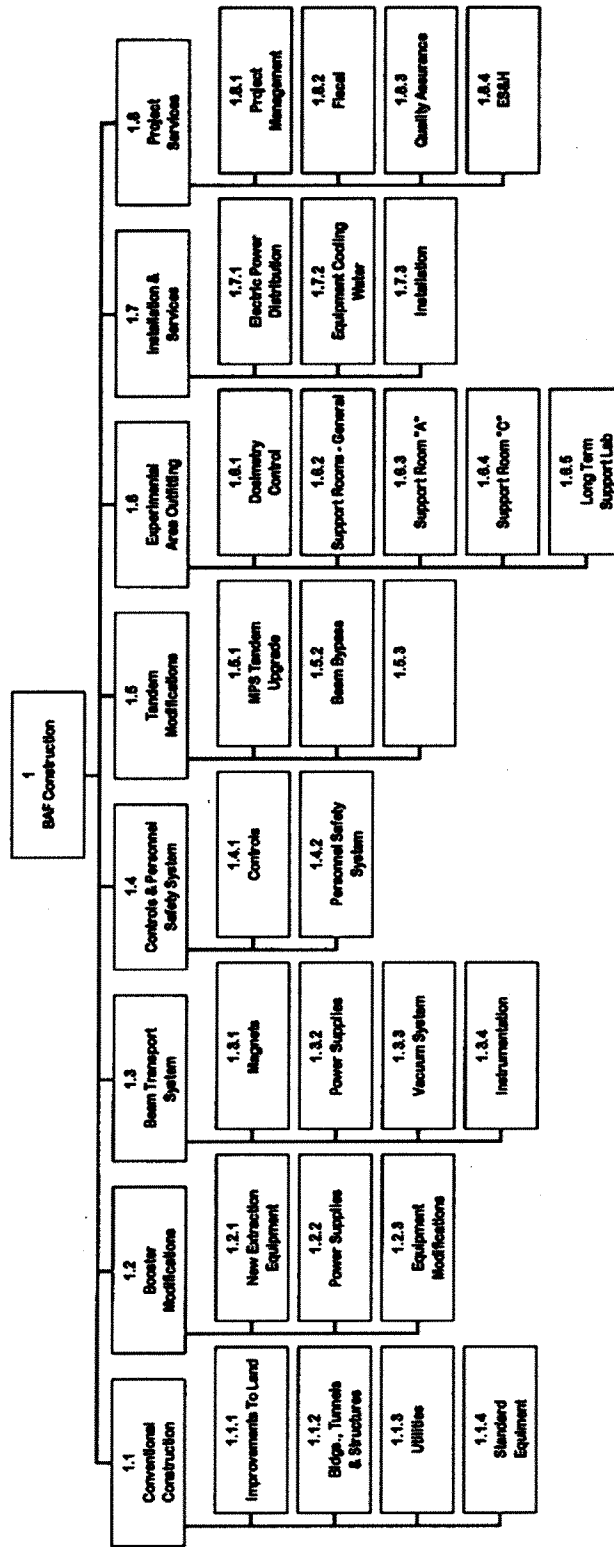

Figure 1.2.1 Project Work Breakdown Structure

#### WBS 1.4 Controls and Personnel Safety System

This WBS includes distributed systems, central services and process controls required for the operation of the Applications Facility. Also included is a relay based personnel access control system that permits entrance to radiation areas only when it is safe to do so.

#### WBS 1.5 Tandem Modifications

The present proposal to deliver interleaved heavy ion beams to the AGS Booster in order to serve simultaneous users at the AGS and also at the proposed Booster Applications Facility requires the second of the two BNL Tandems, MP-6, be upgraded to a terminal voltage of 16 MV and also that its beam be injected into the present HITL beam line. Injection of two different species from the two Tandems, having different masses but identical magnetic rigidities, will allow this scenario. This WBS element will finish the effort necessary at the Tandem Van de Graff (TVDG) to achieve these goals.

#### WBS 1.6 Experimental Area Outfitting

This WBS element provides for dosimetry control, computer systems, electronics and equipment for research in biological systems.

#### WBS 1.7 Installation and Services

This WBS element provides for water cooling, electric power distribution and the installation of magnets, power supplies and related components.

#### WBS 1.8 Project Services

This WBS element provides for project management, budget control, quality assurance and protection of the environment, safety and health.

### 1.3 Cost Summary

The project will begin in the first quarter of FY 99 with Title I engineering for conventional construction and engineering on technical components. Construction will be completed at the end of the second quarter of FY '01. The project cost estimate in At-Year Dollars is \$23.475 million with obligations of \$11.021 million in FY 99, \$11.179 million in FY '00 and \$1.275

million in FY '01. The proposed Cost Summary where WBS elements 1.1 through 1.8 are in FY '98 dollars is as follows:

WBS 1.1	Conventional Construction	\$2,792,000
WBS 1.2	Booster Modifications	\$3,405,000
WBS 1.3	Beam Transport System	\$4,181,000
WBS 1.4	Controls & Personnel Safety System	\$1,248,000
WBS 1.5	Tandem Modifications	\$ 592,000
WBS 1.6	Exp. Area Outfitting	\$1,840,000
WBS 1.7	Installation & Services	\$1,371,000
WBS 1.8	Project Services	\$ 943,000
	Contingency	\$3,138,000
	Overhead	\$2,927,000
	Escalation	<u>\$1,038,000</u>
	TOTAL	\$23,475,000

#### 1.4 Project Schedule

The proposed project schedule includes the following milestones:

- Project Start 10/01/98
- Title I Start 11/01/98
- Booster Modifications Design Start 11/01/98
- Beam Transport System Design Start 11/01/98
- Title I Complete 01/31/98
- Title II Start 03/01/99
- Title II Complete 05/31/99
- Beam Transport System Design Complete 06/30/99
- Booster Modifications Design Complete 07/31/99
- Conventional Construction Start 10/01/99
- Tandem Installation Complete 10/31/99
- Safety Analysis Document (SAD) Complete 06/30/00
- Conventional Construction Complete 09/30/00

- Booster Modifications Installation Complete 09/30/00
- Beam Transport System Installation Complete 10/31/00
- Experimental Equipment Installation Complete 10/31/00
- Project Complete 03/31/01

# Description

**2**

## 2.0 DESCRIPTION

### 2.1 Conventional Construction

The conventional facilities for the Booster Applications Facility will provide approximately 400 sq. ft. of new shielded experimental space, a 2,800 sq. ft. laboratory support facility, a beam transport tunnel and a 2,000 sq. ft. Building for power supplies (see figures 2.1.1 - 2.1.4).

It is proposed to extract the beam from the Booster tunnel through a new 36" diameter steel pipe exiting in a northerly direction. The beam will be transported to the new experimental area through an 11 foot diameter corrugated metal tunnel approximately 250 feet long. A concrete and corrugated metal tunnel service structure will be provided which will also serve as an emergency exit meeting the life safety code. The tunnels will be shielded with 15 ft. of earth cover equivalent .

The experimental area will be a reinforced concrete building with 20 ft. x 20 ft x 10 ft. high interior space. The concrete walls, roof and floor will be four ft. thick with an additional 11 ft. of earth atop the facility for radiation shielding. Equipment and personnel access is provided through a labyrinth from the laboratory support building. A concrete beam stop will be constructed at the downstream end of the experimental area (see Section 2.13 for further discussion of shielding).

The laboratory support building will be a 40 ft. x 70 ft. non-combustible pre-engineered steel frame on concrete footings and foundations with concrete slab on grade and a standing seam metal roof. Exterior walls will be insulated metal panel wall construction. Walls and roof will meet or surpass energy conservation standards with sash of insulated double glazing in thermal break aluminum framework. Space will be provided for two short-term cell culture laboratories, two animal holding and preparation rooms, one biophysics/physics/electronics experiment room, a dosimetry control room, a radioactive storage area, and a mechanical equipment room. Building access will be controlled. Parking will be provided for 20 workers.

Power supplies for the beam transport magnets and various other equipment will be located in a separate 2,000 sq. ft. building adjacent to the transport tunnel. This building will be similar in construction to the laboratory support building.

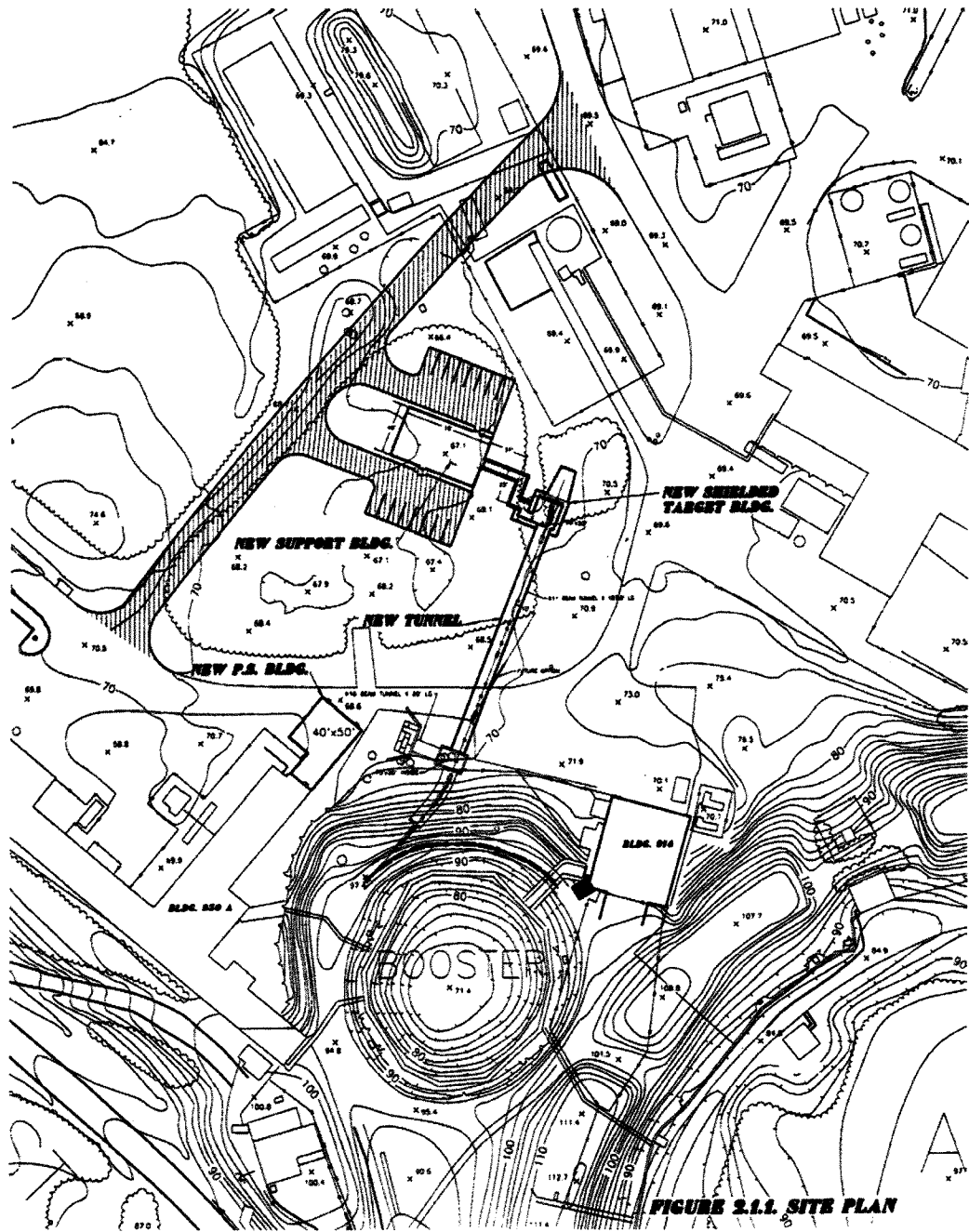

FIGURE - 2.1.1 - SITE PLAN



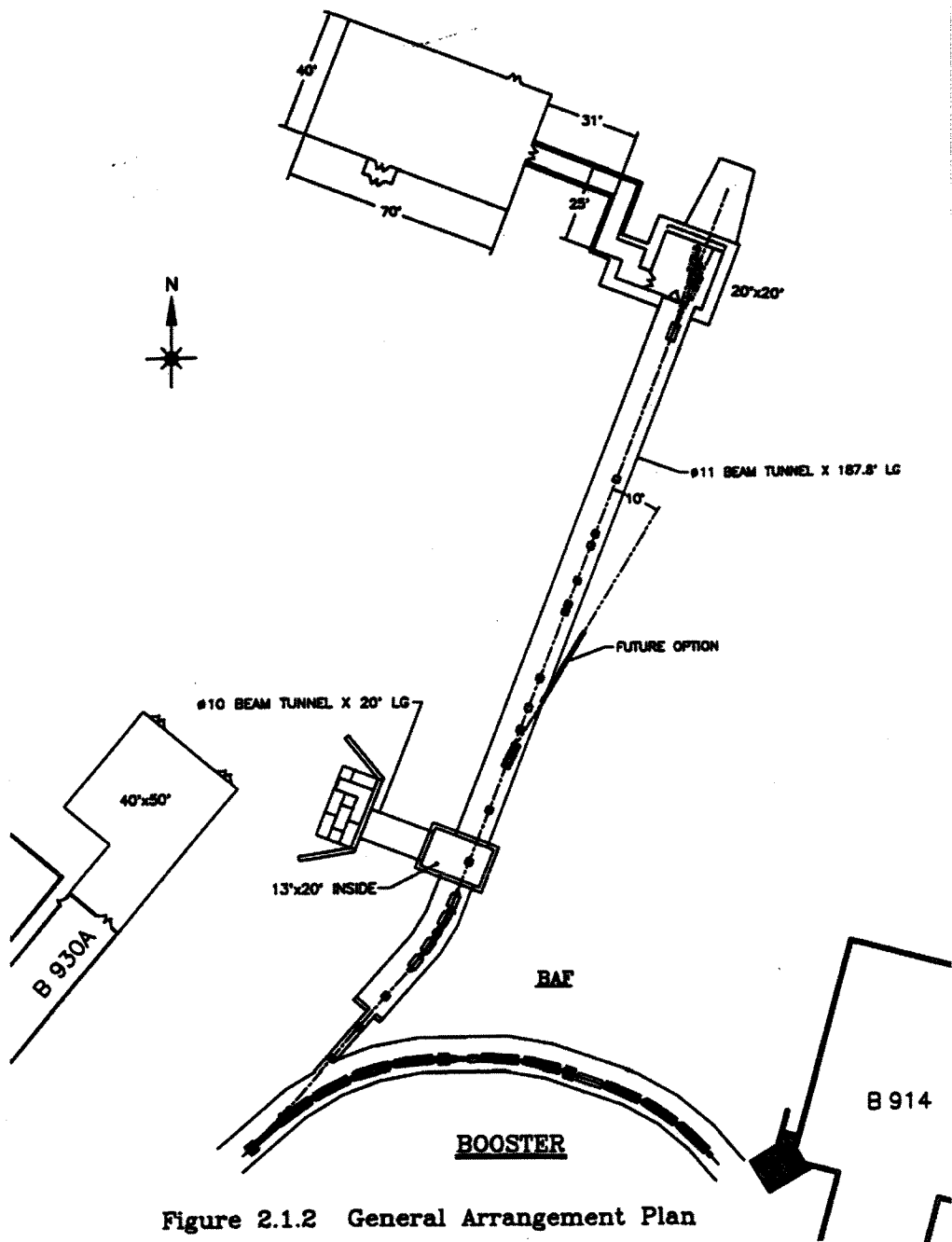
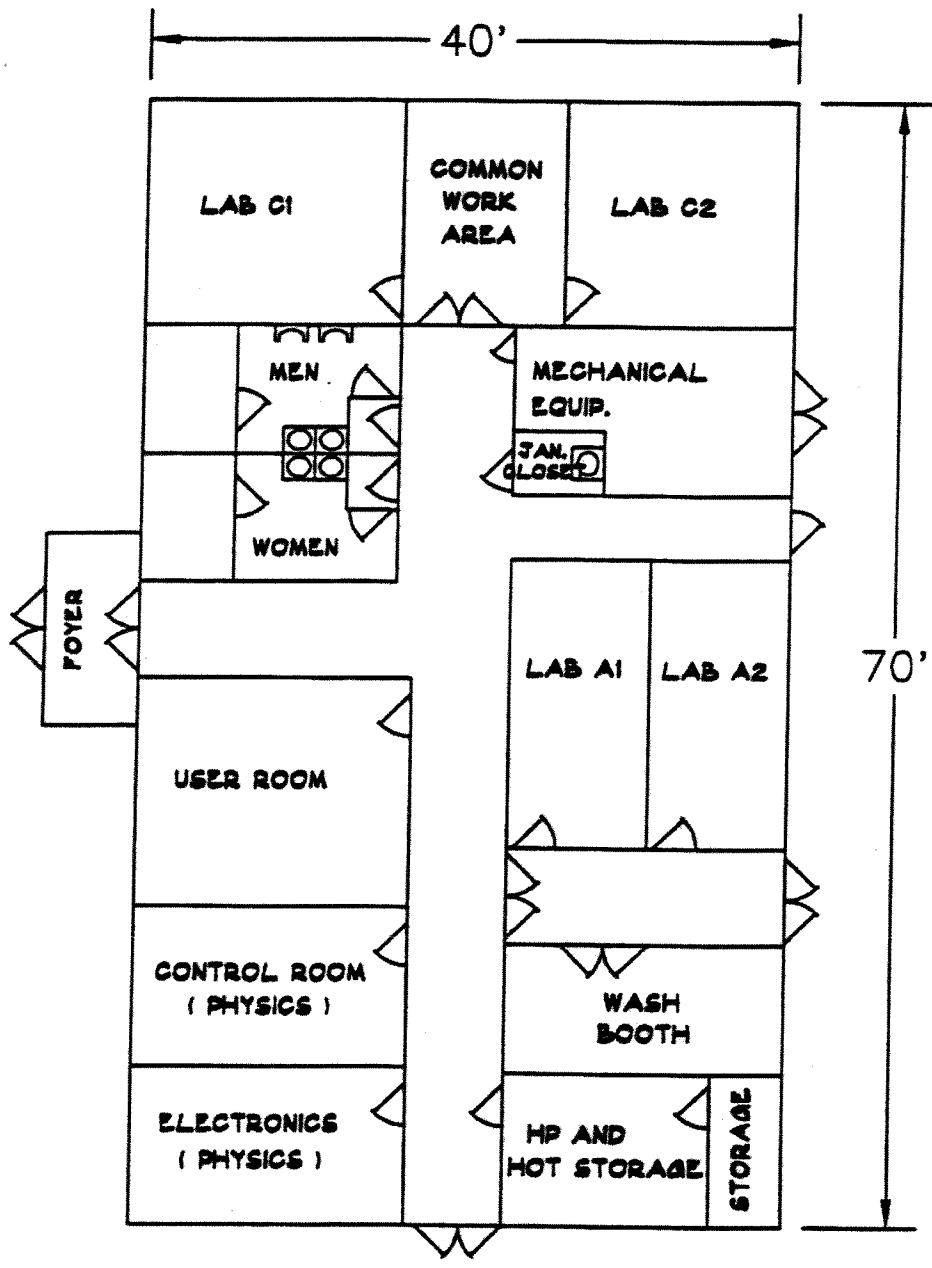

Figure 2.1.2 General Arrangement Plan

FIGURE - 2.1.2 - GENERAL ARRANGEMENT PLAN



SCALE: 0.125" = 12"

FIGURE - 2.1.3 - SUPPORT BUILDING PLAN

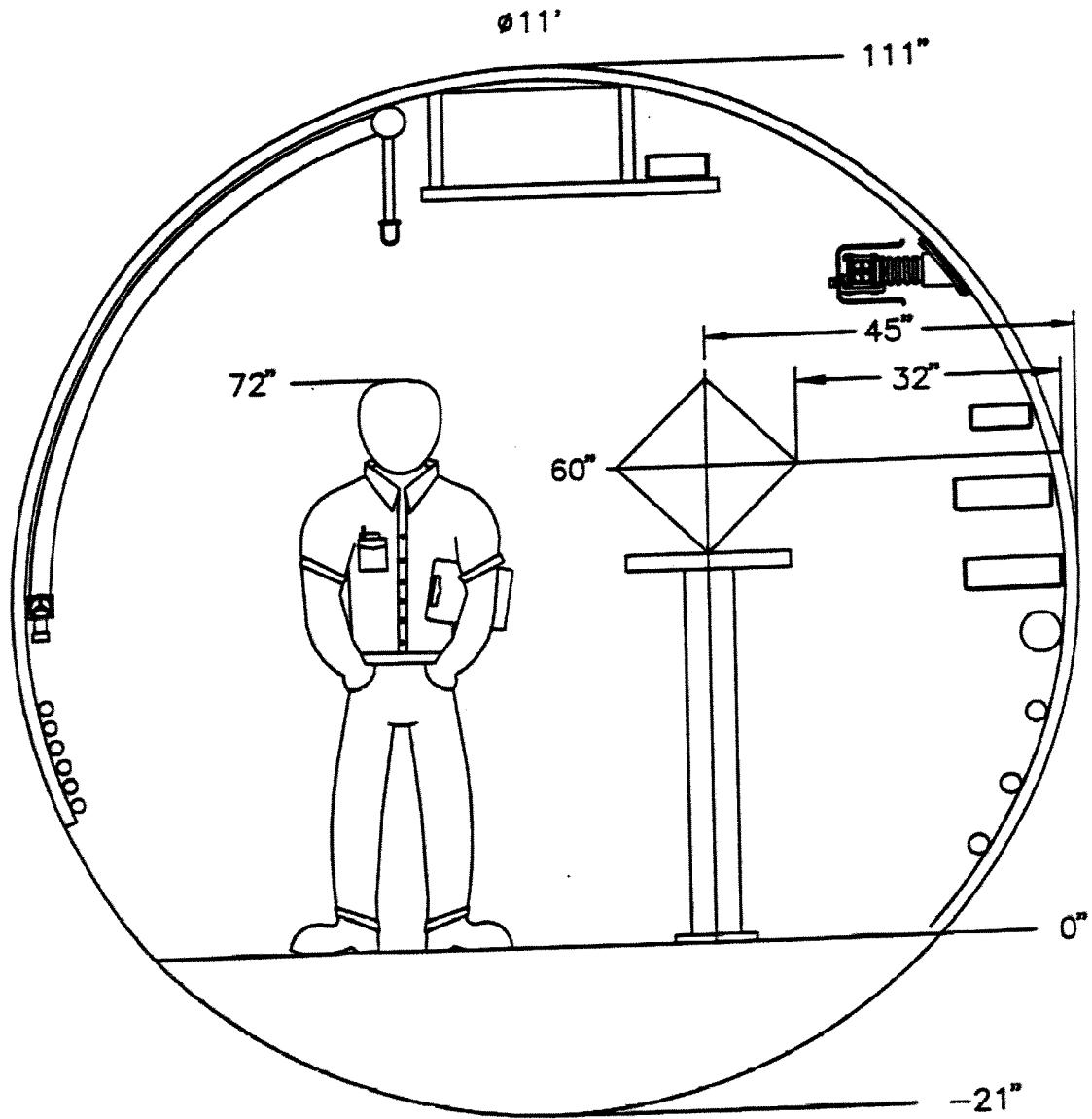

FIGURE - 2.1.4 - TYPICAL TUNNEL CROSS SECTION

The Facility environments will be controlled by an efficient HVAC system designed to optimize energy conservation. Air conditioning will be provided for laboratories and control rooms in the support building and for the power supply building. The facility will be tied into the existing sitewide Energy Management and Control System. The fire protection system will be hydraulically designed, in accordance with NFPA 13. Lighting levels and equipment will be designed to meet the latest DOE energy conservation requirements and to assure low maintenance costs. Laboratory environments will be monitored and recorded with appropriate alarms.

Sitework will include modifications to the existing Booster, concrete walls to retain earth shielding, relocation of existing roadway, and parking. Trenching, excavation, backfilling as well as relocation, extensions, and connections to existing power, water, sanitary and storm sewers, alarm and telephone and computer networks will all be included.

## 2.2 Tandem Modifications

The two BNL Tandem Van de Graff accelerators (MP6 and MP7) will be required as Booster injectors to provide the rapid beam switching capability which will make the BAF operation compatible with RHIC injection. At present only MP7 is connected to the TTB (Tandem to Booster) beam transport line. MP6 needs to be upgraded to the same performance standards routinely achieved with MP7 and a short connecting beam transport line and beam switchyard needs to be built. Some of this work has been performed utilizing operating funds and much of it will be completed with FY 97 and FY 98 Accelerator Improvement Project (AIP) funds. The objectives are the following:

- a) Provide a backup for the RHIC injector to avoid lengthy program interruptions due to unscheduled maintenance.
- b) Provide rapid beam switching capability to deliver heavy ions to BAF during normal RHIC operation.
- c) Provide rapid beam switching capability to deliver two different beams to RHIC for experiments requiring unequal beam collisions.
- d) Provide heavy ions to the local Tandem applied program when such operation is compatible with RHIC and BAF requirements.

Figure 2.2.1 shows the beam transport and switchyard connecting the MP6 Tandem Van de Graff accelerator to the existing TTB line and to the Tandem target rooms.

Tables 2.2.1 through 2.2.3 outline the total remaining work much of which will be covered by FY 97 and FY 98 AIPS and by some user contributions. The sources of funds are also included.

Table 2.2.1 - MP6 Upgrade Completion

TASK START DATE	FUNDING: FY '97 AIP
10/96	Start MP6 column upgrade
10/97	Insulating gas system upgrade
10/97	Column modifications
11/97	MP6 vacuum system upgrade
11/97	Order three Pelletron chains and pulleys
11/97	Electrical power for drive shaft and Pelletron
12/97	First High voltage testing without tubes
2/98	Complete MP6 column upgrade
3/98	Install acceleration tubes and vacuum components
3/98	Order three Pelletron chains
6/98	MP6 voltage and beam tests

Table 2.2.2 - Beamline and switch yard modification

TASK START DATE	FUNDING: FY'98 AIP AND USER
12/97	Order four 25 degree dipole magnets
12/97	Order vacuum power distribution and utility components
1/98	Begin fabrication of beam line components
1/98	Order vacuum system equipment
2/98	Dipole support and stair modifications
2/98	Order beam diagnostics
3/98	Fabrication of vacuum beam line components
4/98	Install steerers and quads in beam line
4/98	Install vacuum power distribution
5/98	Rigging of dipoles and supports
6/98	Vacuum component fabrication and installation

2.2.3 - Supplies, Controls and Instrumentation

TASK START DATE	FUNDED BY BAF PROJECT
1/99	Order quad and steerer supplies
1/99	Control system
1/99	Order 4 dipole supplies
1/99	Order radiation safety system
6/99	Power supply installation and power distribution (dipole and quad supplies)

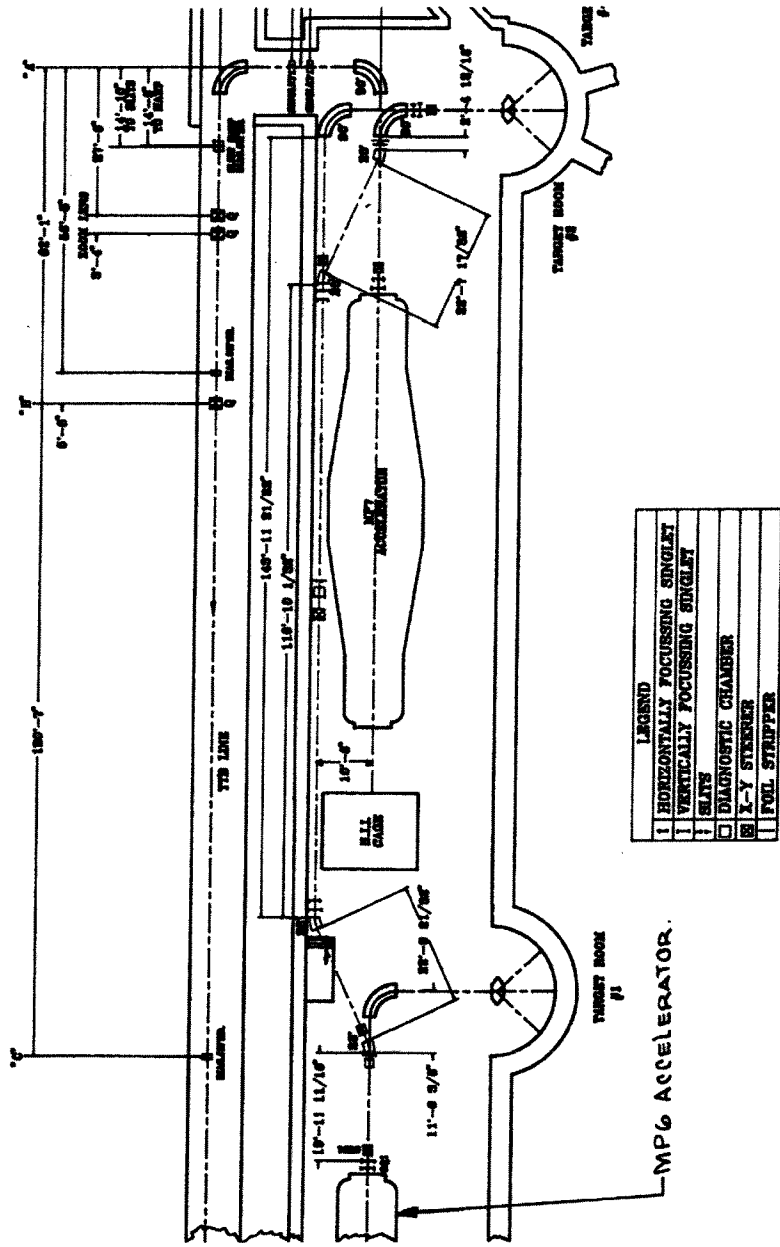

Figure 2.2.1 Tandem Modifications

FIGURE - 2.2.1 - Tandem Modifications

### 2.3 Slow Extraction at the Booster

The Booster has operated since 1991 as an injector of protons and heavy ions into the AGS. The operating parameters are shown in Table 2.3.1. In order to deliver an external slow extracted beam to the Booster Applications Facility the need for new equipment will result in some rearrangement of existing apparatus. A summary of the changes is shown in Figure 2.3.1 and described in Section 2.5. The operating cycle will be different than that required for AGS injection and in order to provide the most versatile experimental beam, some changes will be made in the range of energies and intensities available in the slow extraction mode, as shown in Table 2.3.2. The maximum kinetic energy of the range given is based on the maximum Booster rigidity of 17 Tesla-meters (T-m) for the heavier ions that are fully stripped at the stripping foil located in front of the extraction septum D6 and by the maximum beam transport rigidity of 13 T-m for the lighter ions. The minimum kinetic energy is obtained from the requirement to transport through the D6 septum magnet without significant beam loss. Lower energies are possible at a lower intensity. Note that intensities as low as  $10^6$  ions per pulse listed will always be available to experimenters by collimating the extracted beam, with a single jaw collimator located in front of the D6 septum.

#### Machine Physics to Achieve Slow Extraction

The main challenge in designing the slow extracted beam (SEB) system for the Booster Application Facility (BAF) is to add a flexible extraction system, which is capable of extracting the ions uniformly for a duration of several hundred to one thousand milliseconds, without any significant impact on the existing subsystems including the single turn fast extracted beam (FEB) system for beam transfer to the AGS.

The Booster consists of six superperiods and each superperiod has two long straight sections. The machine will be modified in order to place the extraction magnet at D6, this permits the construction of the experimental area in one of the few available spaces outside the Booster.



TABLE 2.3.1

## AGS BOOSTER PARAMETERS

CIRCUMFERENCE	201.78 m (1/4 AGS)
AVERAGE RADIUS	32.114 m
MAGNETIC BEND RADIUS	13.75099 m
LATTICE TYPE	Separated function, FODO
NO. OF SUPERPERIODS	6
NO. OF CELLS	24
BETATRON TUNE, X, Y	4.82, 4.83
NUMBER OF MAGNETS	36 Dipoles, 48 Quads
MAGNET TYPE	Iron-Dominated Water-Cooled Cu Conductor
DIPOLE LENGTH (Magnetic/Physical)	2.4/2.34 m
QUAD LENGTH (Magnetic/Physical)	0.50375/0.472 m
VACUUM CHAMBER DIMENSION	70 x 152 mm, Dipoles 152 mm (Circular), Quads
MAXIMUM RIGIDITY	17 Tm
ACCELERATION RATE	8.9 T/s up to 7.5 Tm (7.5 Hz Rep. Rate) 1 T/s up to 17 Tm (0.7 Hz Rep. Rate)
INJECTION RIGIDITY	2.2 Tm (200 MeV Protons) 0.9 Tm (1 MeV/nuc Au(32+))

TABLE 2.3.2

## Operating Parameters for Slow Extraction for some Typical Ion Species

Species	Charge State in Booster	Kinetic Energy Range [GeV/nucleon]	Estimated Max. Intensity [10 <sup>9</sup> Ions per Pulse]
p	1	0.73 ... 3.07	100
28 Si	14	0.09 ... 1.23	4
56 Fe	21	0.10 ... 1.10	0.4
63 Cu	22	0.10 ... 1.04	1
197 Au	32	0.04 ... 0.30	2

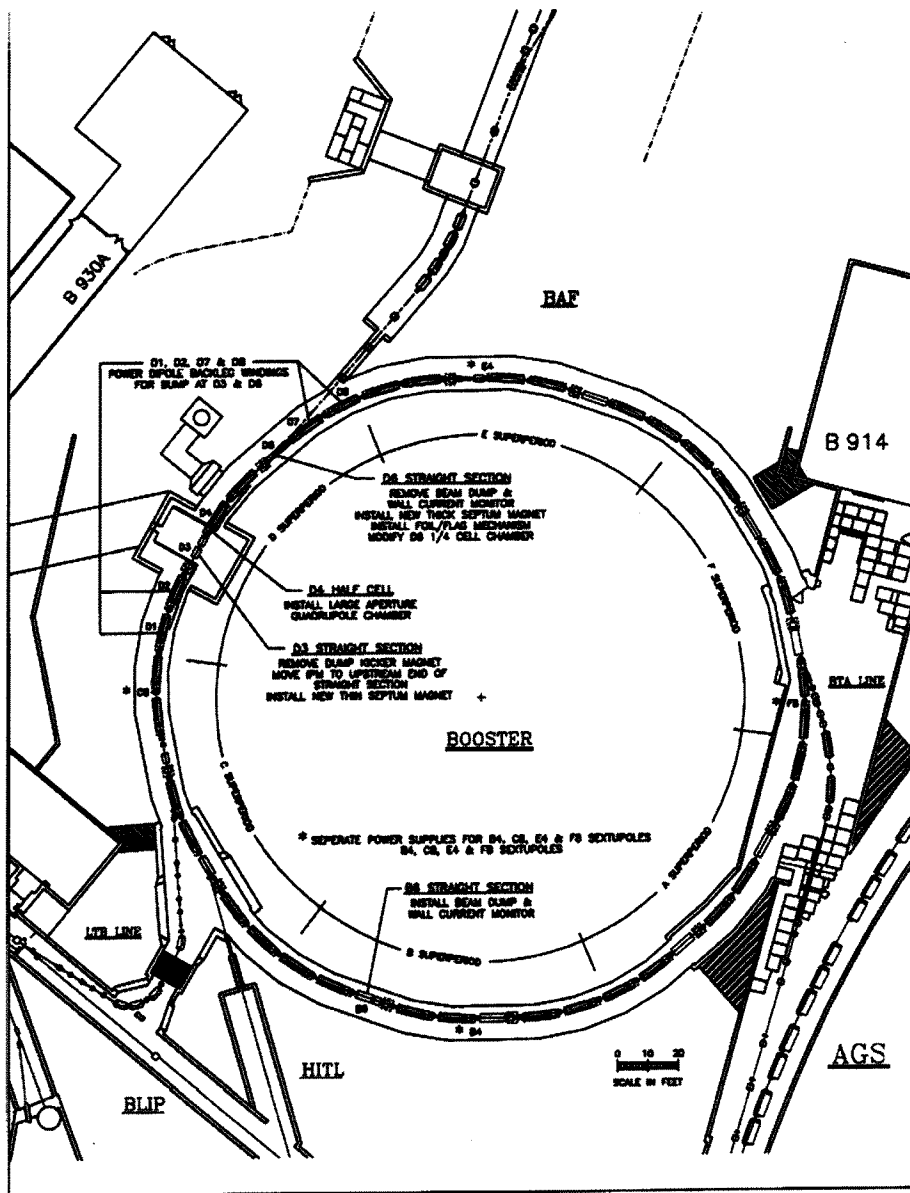

FIGURE 2.3.1 - BOOSTER MODIFICATION FOR SLOW EXTRACTED BEAM

FIGURE - 2.3.1 - Booster Modifications for Slow Extracted Beam

Slow extraction is achieved by the controlled excitation of a non-linear betatron resonance, typically a third integer resonance. A slow spill is usually controlled by steering the beam slowly so that particles with different momenta move progressively onto the resonance. Third order resonance extraction has been used at the AGS for many years for the high energy and heavy ion physics programs, as well as for the radiobiology program. It has proved to be very efficient and reliable with an extraction efficiency of about 96%. For the Booster, the slow extraction system will also make use of the horizontal third integer resonance at the resonance tune of  $Q_h = 13/3$ . The extraction scheme with a tune that is significantly lower than the nominal tune listed in Table 2.3.1 is required because the Booster tune quadrupoles do not have enough strength to maintain the horizontal betatron tune at the value of  $14/3$  up to the highest energies. To reach even  $13/3$  at 12 T-m a new power supply for the tune quadrupoles is needed. The required crossing of the half integer resonance at  $Q_h = 9/2$  during acceleration can be accomplished easily with the fast slew rate available from the tune quadrupole system.

The third integer resonance can be excited by the 13<sup>th</sup> harmonic of two sextupoles pairs located at C8, F8, B4 and E4. Since the Booster ring is rather congested with equipment, it is planned to utilize four of the existing 24 horizontal lattice sextupoles as drive sextupoles. The maximum field strength of the existing lattice sextupoles is sufficient for their use as drive sextupoles. At the third integer resonance, a stable triangular region of the horizontal phase space is defined within three linear separatrices and the area and orientation of this region can be controlled by the drive sextupoles. In the vicinity of the resonance there is a small range of tunes over which the separatrix degenerates into three narrow legs which have a phase advance of  $2/3\pi$  radians with respect to each other. A particle leaving the stable area within the separatrix moves out along one of these legs as it spirals out of the machine.

The efficiency of slow extraction depends on the thickness of the first septum as compared to the growth of the resonant betatron amplitude in the final few turns before extraction, which is termed the spiral pitch or step size. For this reason, the first septum is made as thin as possible and is aligned precisely so that the maximum growth per turn can be obtained for the available aperture and for the beam emittance. The spiral pitch of the particle depends on its momentum, amplitude and its proximity to the resonant tune value as

well as the drive sextupole strength.

The first thin septum is located in straight section D3 and the final thick septum is installed in D6. The phase advance between these two locations is about 71 degrees. This means that an angular kick from the thin septum at D3 will translate into a large displacement at D6.

Thus, the SEB extraction system will consist of a thin magnetic septum at straight sections (SS) D3, thick magnetic septum at SSD6, four lattice sextupoles used as drive sextupoles and slow orbit bumps centered at SSD3 and SSD6. The Booster lattice functions over one superperiod are shown in Figure 2.3.2.

The thin septum at D3 is located 50 mm away from the central orbit and has an effective septum thickness of 0.76 mm. The maximum kick is 3 mrad for the length of 1 m, assuming a maximum rigidity of 17 T-m. The magnetic septum at D6 has an effective septum thickness of 15.2 mm and is operated in a dc mode, giving a kick of 143 mrad with a length of 2.30 m. Drive sextupoles have the maximum normalized strength of

$$K_s = B_2 L / B\rho = 0.29$$

$\text{m}^{-2}$  where  $L=0.1$  m. In order to study the basic dynamical aspect of the extraction system simulations using the appropriate Booster lattice parameters have been performed. Figure 2.3.3a shows the pattern of phase space growth at the thin magnetic septum with drive sextupoles at C8, F8, B4 and E4. The tune  $Q_h$  is set to 13.3333 for the particle on the closed orbit and to 13.3334 for the particle with emittance of  $15\pi$  mm mrad. The two pairs of drive sextupoles are powered with opposite sign at a strength of  $K_s = 0.25 \text{ m}^{-2}$ . A slow  $1/2\lambda$  orbit bump at SSD3 will bring the center of the closed orbit about 38 mm from the thin septum where the particles inside the septum will be kicked 3 mrad. The spiral pitch is about 4.0 mm.

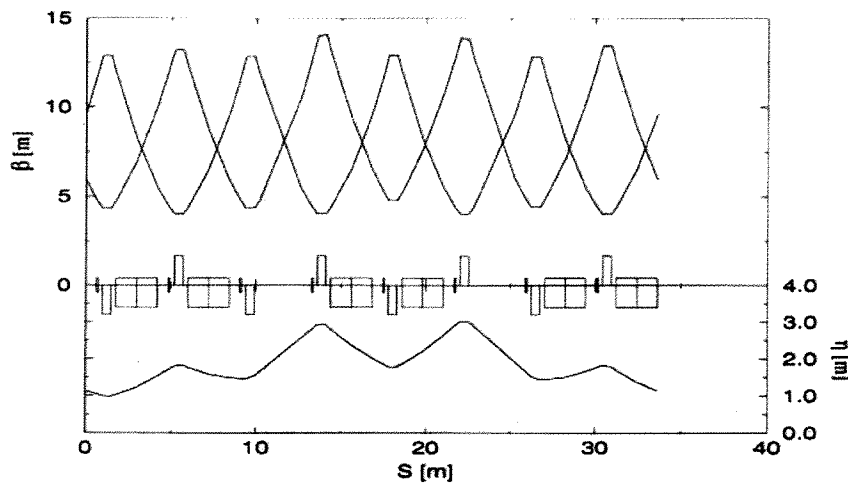

Figure - 2.3.2 AGS Booster lattice functions

Similarly, the phase space at the thick magnetic septum at SSD6 is shown in Figure 2.3.3b. The kicked particles appear on the inside of the septum with a clearance of 24 mm away from the closest part of the circulating beam. At this point the particles are deflected by the ejector magnet and extracted from the ring to the BAF. The simulation was performed for a  $15\pi$  mm mrad beam emittance corresponding to the vertical acceptance of the D6 septum. The vertical emittance of the extracted beam is unchanged by the extraction process. To first order, the horizontal emittance is zero as the phase space area of the extracted beam, as shown in the simulation, is completely determined by the momentum spread. However, a significant amount of dispersion is generated by the extraction process. The extracted beam passes through the stripping foil before entering the D6 septum magnet. The thickness of the foil can be adjusted to not only completely strip the ions but also provide a large enough horizontal emittance to allow for a uniform beam spot at the target area. For the beam transport calculations discussed below we used a horizontal emittance of  $3\pi$  mm mrad. This would require a 0.08 mm thick copper stripping foil for a 1 GeV/nucleon Fe beam. The beam parameters used for the beam transport calculations are summarized in Table 2.3.1.

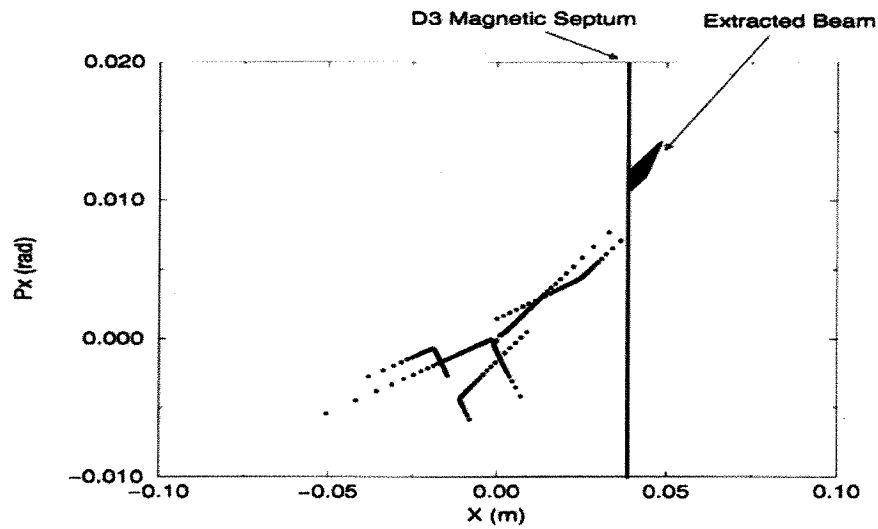

Figure - 2.3.3a Phase space at D6.

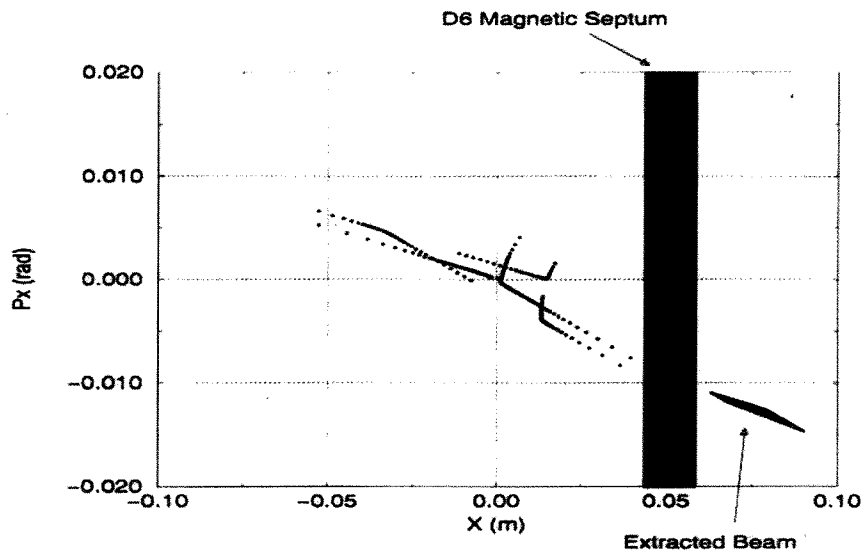

Figure - 2.3.3b Phase space at D6.

The extraction efficiency is estimated to be about 70 - 80%, which is given by the ratio of the effective thickness of the thin septum to the step size. Since the SEB beam intensity and energy for the BAF is rather low, this value is quite acceptable.

It is expected that pulse-to-pulse intensity variations will lie within 25% of the long-term average. Ripple within a pulse is dealt with in Section 2.4.

#### 2.4 Spill Control

The desirable performance for the spill control system is a spill period of 0.1 to 1 second with low frequency ripple during the spill held within 20% for a de-bunched beam. In order to achieve a constant stable output beam intensity sophisticated control systems are needed in combination with low-ripple power supplies for the main magnets and extraction magnets.

The beam can be de-bunched and extracted using the 13/3 resonance described earlier and low frequency control of the spill will be provided by adjusting the main magnet supply. Since the 13/3 resonance is sensitive to momentum of extracted ions, the extracted ion energy varies during extraction by about 0.5 percent. The extracted momentum is higher at the beginning of the spill and lower at the end. This method of extraction and spill control has been used at the AGS for many years. A closed-loop servo will be required which is gated on at the beginning of the flattop part in the operating cycle. A measurement of the extracted beam spill is compared to a reference signal and generates a correction output signal that controls the Booster main magnet flattop and the low frequency part of the spill. A simplified version of the scheme is shown in the block diagram of Figure 2.4.1.

The high frequency control of the spill is controlled by reducing the ripple of all power supply components involved in generating the slow extracted beam. Alternately, high frequency feedback of ripple components up to 1-2 KHZ can be applied. (In the present design, this is not included).

As can be seen in the figure, the spill servo system's major parameters are controlled by a computer and its output feeds the Booster main magnet power supply (MMPS) electronics. The system only acts on the MMPS during the flattop portion of its cycle and during all other times it is off. The major spill parameters that can be set are the start and the duration or length of the spill, and the gain of the loop. Other controls are open/closed loop operation, normal or beam inhibit mode, and learned mode. The computer also monitors the status of the system.

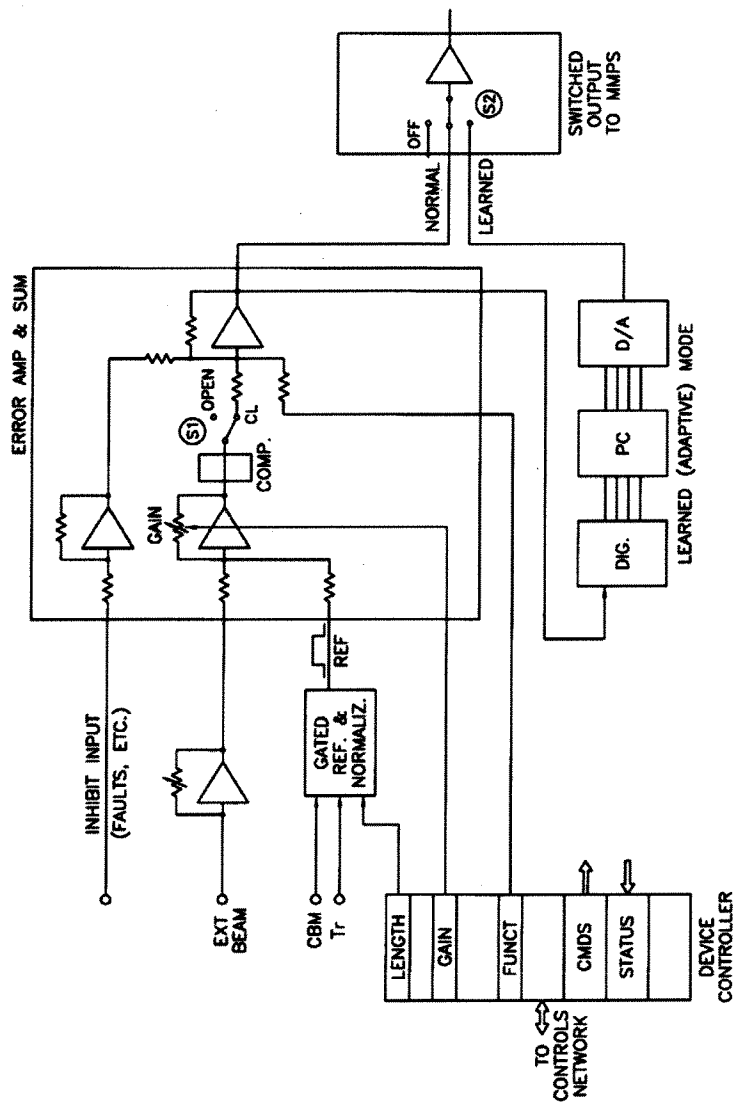

Figure 2.4.1 Servo for Spill Intensity Control in De-Bunched Mode

FIGURE 2.4.1  
SERVO SYSTEM TO CONTROL BEAM SPILL INTENSITY IN BUNCHED MODE



## Bunched Beam

In case the momentum variation of the extracted beam is not desirable, it is possible to extract ions in rf bunches at constant extraction momentum. To investigate ripple performance against power supply costs, the system was examined for the specific example of extracting 1 GeV/n Fe ions. The main field was assumed to be held constant during the spill period and the RF acceleration system was assumed to be in operation. The major characteristics of the investigation are given in Table 2.4.1.

**Table 2.4.1**

### **CHARACTERISTICS OF SPILL CONTROL INVESTIGATION**

Species	56 Fe (21)
$\beta$ (velocity/c)	0.8750
Radio Frequency	3.9003 MHz
Momentum	94.98 GeV/c
Energy	56.0 GeV
Field	1.0972 T
RF Voltage	90 kV
Harmonic No.	3
Synch. Freq.	8.7 kHz (bucket Center)
RF Bucket $\Delta P_{\max}/P$	0.29%
Spill Length	0.5s
Resonance Time Constant	$\sim 250\mu\text{s}$ ( $\sim 300$ Turns)

Spill ripple is caused by fluctuations of the power supply for the main magnet dipoles and quadrupoles, quadrupole correctors, orbit bumps and extraction sextupoles. The change in field can be related to a change in the intensity of the extracted beam. With the rf system on, spill control servo is used to control the ripple in the extracted beam below 300 Hz. This servo compares the intensity of the extracted beam with a reference signal and

produces a control signal for the RF low level system, see Figure 2.4.2. The beam intensity monitor is discussed in Section 2.11. The RF is programmed in order to cause a constant number of ions to cross the extraction resonance line per unit time. The frequency function depends on the distribution of ions inside the RF bucket and will be set empirically to give constant spill. Imperfections in this function will also cause spill ripple. The RF cavities in the Booster have relatively low Q, thus the servo can produce fast changes for small frequency corrections without gain roll-off. The external reference signal can be automatically programmed to minimize spill ripple based on an average of the last few bunches. The signal from the beam intensity monitor causes a change in the acceleration frequency thus raising or lowering the central momentum of the bunch.

The bandwidth of the servo should be below the synchrotron frequency of the Booster; about 9 kHz in the case studied. In principle, the servo should effectively compensate for main magnet ripple of the order of  $10^{-4}$ , but it is expected that low frequency spill ripple will be somewhat higher with bunched beams compared to de-bunched beams. The measured main magnet ripple current is considerably better than 1 part in  $10^4$ .

For the case studied the calculated spill ripple is shown in Table 2.4.2.

TABLE 2.4.2  
Estimation of Spill Ripple for 1 GeV Fe Ions

Ripple Frequency (Hz)	60	120	360
Measured MMPs Ripple (V)	<3	9	14
Field Ripple $\times 10^{-5}$	<1.4	0.6	0.03
Resonance Process Attenuation Factor	0.75	0.53	0.28
Spill Ripple w/o Frequency Servo, $I_{PK}/I_{DC}$	<2.4	1.5	0.11
Spill Ripple w/Frequency Servo, $I_{PK}/I_{DC}$	<0.6	0.5	0.08
De-Bunched Beam	<0.2	0.1	0.01

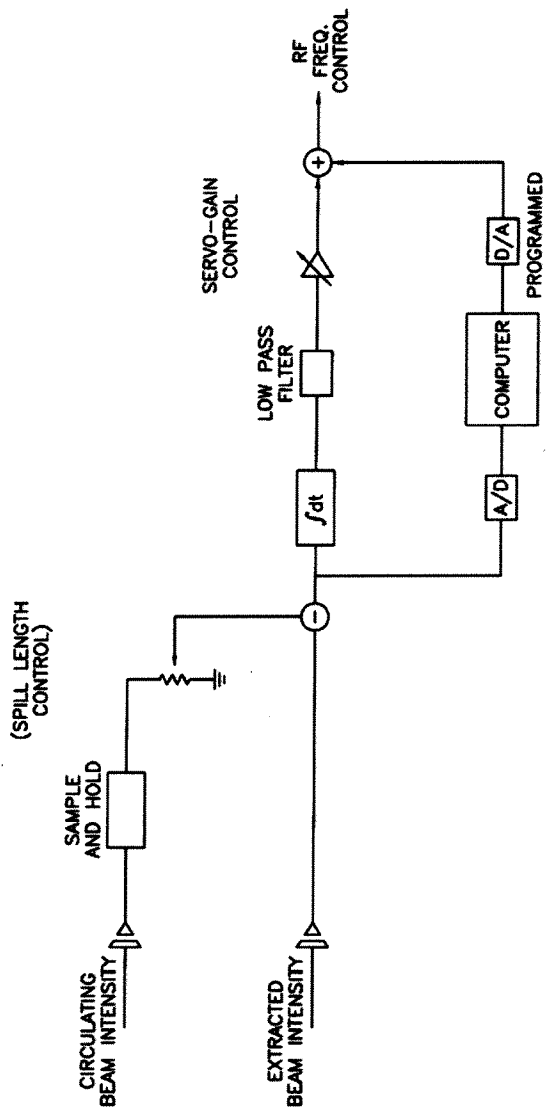

Figure 2.4.2 Servo System to Control Beam Spill Intensity in Bunched Mode

FIGURE - 2.4.2

SERVO SYSTEM TO CONTROL BEAM SPILL INTENSITY IN BUNCHED MODE

## 2.5 Modifications to the Booster

New extraction magnets will be required for slow extraction to the BAF line. The method of extraction is described in section 2.3. To make room for the new magnets other equipment in the Booster will have to be moved or removed.

### New Devices

#### (Thin Septum Magnet)

The thin septum magnet will be the most difficult mechanical component to design for the new slow extracted beam system. It will be similar in design and specification to the F5 extraction septum used in the AGS but it will have to be built to  $10^{-11}$  Torr UHV vacuum standards. To meet this UHV requirement the individual internal steel and stainless steel components and the vacuum chamber will have to be vacuum fired at  $950^{\circ}\text{C}$  and assembled in a clean room. A thin 0.76 mm copper septum will be used to minimize beam loss. Inconel water lines will be brazed to each edge of the septum as shown in figure 2.5.1 to cool it. Designing a reliable internal water cooling system and insulating the high current septum in the bakeable UHV system will be the most difficult tasks. Another cost driver will be the remote positioning system required to optimize the septum's orientation for the various extracted beams.

#### (Thick Septum Magnet)

This septum magnet will be similar in concept to the present F6 extraction septum magnet used for the Booster. The magnet core and the water-cooled copper bus work will be located outside of the vacuum. A special "Y" chamber will be used with an inconel chamber for the extracted beam which fits in the aperture of the magnet. The Booster circulating beam goes in a nickel-plated steel chamber which is welded to the inconel chamber at the upstream end. The septum magnet must be on at full field throughout the 0.5 to 1.0 second extraction time. Because of this, heating of the septum conductor will be significant even with water cooling. The magnet will have to run DC to prevent the heating and cooling cycles from causing fatigue stress failures in the copper conductor or friction wear problems with the insulation. This magnet will be built with four small conductor windings in the septum and the backleg. This

### SPECIFICATIONS

FIELD, B	.52 KG
BEND ANGLE	3 m Rad @Be = 16.7 TM/Rad
STRAY FIELD	< 2 G
CURRENT	1100 AMPS, PULSED
LENGTH IRON	100 Cm
GAP	2.54 Cm VERT. X 5.08 Cm HOR.
POWER	1.1 KW MAX.
TURNS	1
SEPTUM	.76 mm THICK
WATER FL.	4 l/min.
RESISTANCE	.001 OHMS

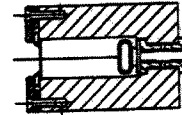

FIGURE 2.5.1 - THIN SEPTUM MAGNET

### SPECIFICATIONS

FIELD, B	8.1 KG
BEND ANGLE	143 m Rad @Be = 13.0 TM/Rad
STRAY FIELD	< 1 G
CURRENT	4100 A
LENGTH IRON	230 Cm
GAP	2.54 Cm VERT. X 7.50 Cm HOR.
POWER	85 KW
TURNS	4
SEPTUM COND.	0.8 Cm X 0.6 Cm
TOTAL SEPTUM THK.	1.52 Cm
WATER FL.	120 l/min.
RESISTANCE	.005 OHMS

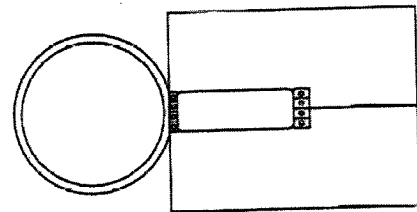

FIGURE 2.5.2 - THICK SEPTUM MAGNET

design is used in the AGS F10 extraction septum magnet which operates DC with similar currents.

To meet the UHV requirement the steel, stainless steel, and inconel components of the vacuum chamber will have to be vacuum fired at 950°C and assembled in a clean room. The entire assembly including the magnet core, copper conductor, and associated insulation will have to be bakeable to 300°C to meet the Booster vacuum bakeout requirements. Figure 2.5.2 shows the end configuration of this magnet.

Figure 2.5.3 and 2.5.4 show installations into the D6 and D3 straight section.

A stripping foil mechanism and a radial single jaw collimator will be required upstream of the thick septum magnet. This foil holder/changer will be similar in design to the mechanism currents used for Booster H<sup>-</sup> injection. The mechanism will have to be re-engineered to minimize the amount of space that it takes at the upstream end of the septum magnet. To aid with the setup of the extracted beam, it will have a flag position with associated camera port, light port, and camera mounting hardware in the tunnel.

#### Equipment Modification And Relocation

To make room for the new extraction magnets, some of the existing equipment in the Booster will have to be moved or removed. Figure 2.3.1 shows the Booster with a listing of the systems which must be installed, modified, moved, and/or removed.

#### D4 Half Cell And D6 Quarter Cell Modifications

The extraction orbit bumps and the new thin septum at D3 will move the extracted beam far off the horizontal beam axis. To provide a larger horizontal aperture the upstream end of the D4 half cell will have to be modified. A new "eared" vacuum chamber will be built for the quadrupole/sextupole chamber. Modifications to the bus work of both the quadrupole and sextupole will be required. The new thick septum will have to be positioned upstream as far as possible in the D6 straight section. To provide space the downstream end of the D6 Quarter Cell chamber will have to be shortened and a bellows will be added to fit within the quadrupole magnet coil. Because of ALARA considerations and the extent of the modification, new chambers will be fabricated rather than doing extensive rework on the radioactive parts. All of the new components will have to be vacuum fired and assembled in accordance with Booster UHV specifications. To remove the old chambers and install and survey in the new chambers, the entire 1/2 cell and 1/4 cell assemblies will have to be removed from the Booster tunnel.

### The Beam Dump And Wall Current Monitor

In order to provide space for the new thick septum magnet, the equipment presently in the D6 straight section must be moved. The only available long straight section is at B6. There are two problems associated with moving the beam dump. First, the D6 area of the Booster has a special cover on the earth shielding berm to prevent activation of rain water which may percolate through the soil adjacent to the tunnel. A new land fill type cover will have to be installed over the B6 straight section. The cost for this is included. The second item is the stand for the beam dump. The present stand was designed to hold additional shielding for the dump. This stand makes installation and removal of the dump very difficult. The stand itself will be difficult to remove. It was installed before many other components during the original construction and may have to be cut for removal. A new stand, shield and dump support will be designed for the new dump locations. An adapter fixture will also be designed and fabricated so that the dump can be installed with the Booster transporter. The move of the wall monitor will be much less traumatic. New cables will be required at the new location. A new vacuum spool piece with heater blanket will be required to match the B6 straight section. Because a kicker magnet will not be used with the new dump position a special wide aperture chamber will not be required for the B6 quarter cell.

### D3 Straight Section

The optimum location for the thin septum is at the downstream end of the D3 straight section. Presently the beam dump kicker magnet and the ionization profile monitor (IPM) occupy this straight section. The beam dump kicker magnet will be removed because it is no longer needed due to the move of the beam dump. This will include removing its stand, associated cabling, power supplies, and control racks from the tunnel and building 930A. The IPM will then be moved into the upstream end of the straight section. The IPM move will require moving a Booster dipole magnet bus stand and a new high voltage cover for the IPM (see figure 2.5.4).

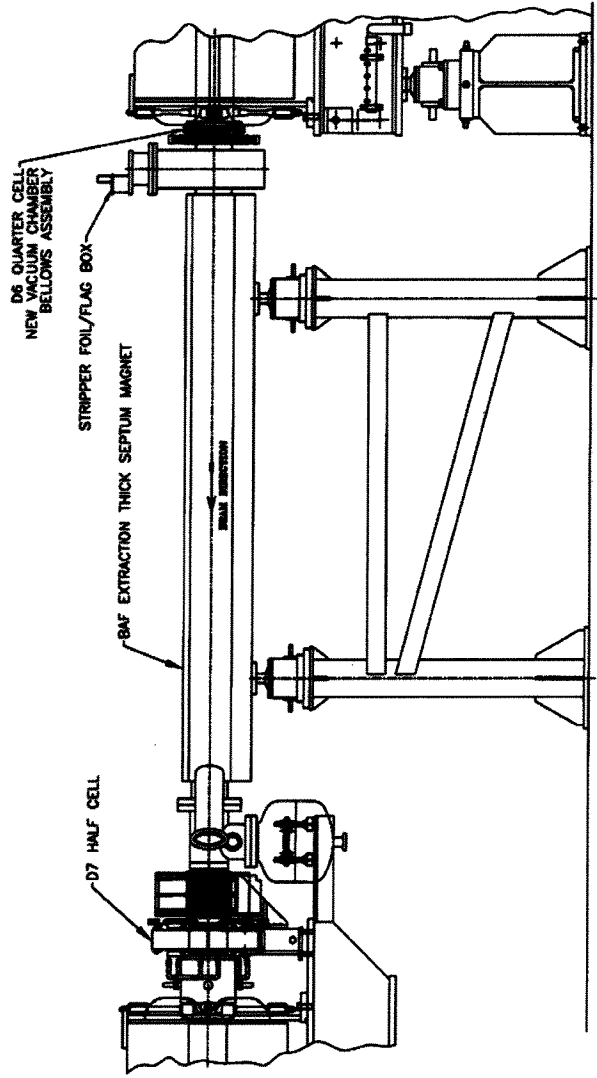

FIGURE 2.5.3  
INSTALLATION OF THE THICK SEPTUM IN D6 STRAIGHT SECTION



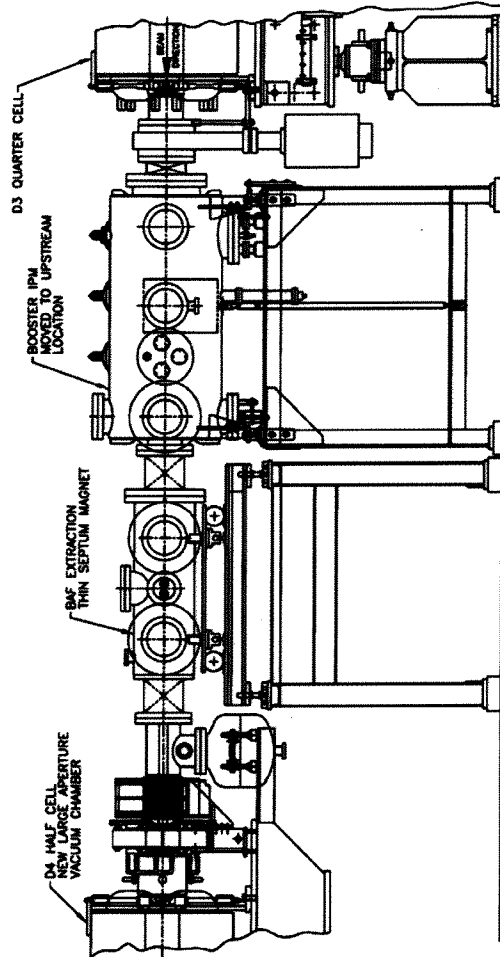

FIGURE 2.5.4  
INSTALLATION OF THE THIN SEPTUM AND IPM IN D3 STRAIGHT SECTION

### Vacuum System Modification In The Booster Tunnel

Associated with the moves and new equipment installations will be modifications to the vacuum system in the tunnel. The major hardware pieces are new vacuum chambers, flanges, chamber modifications, heater blankets, wiring in the bake out blankets, additional heater relay boxes, updating the bake out computer control software and testing the system. After installation is complete, extensive leakchecking and final bakeout will be required.

### 2.6 Beam Transport Design

The beam transport line delivers the extracted Booster beam from the extraction point of the Booster, to the target in the experimental area and also provides the required beam

profile on the target. The transport line starts at the beginning of the D6 straight section of the Booster, and ends at the target which is located 100 m downstream. The layout of the magnetic elements which will be used to transport and shape the beam on target is shown in Figure 2.6.1, and a brief list of these elements is given below.

- a) The thick septum magnet, placed just after the (D6) Booster extraction point, bending the beam by  $8.2^\circ$  (143 mrad) to the left, thus extracting the beam from the Booster ring.
- b) Four consecutive dipoles, each 1.27 m long with 83 mm gap, each bending the beam by  $5^\circ$  for a total of  $20^\circ$  bend to the left to direct the beam into the final straight section of the tunnel. These dipoles will be placed at a distance of  $\sim 27$  m from the beginning of the beam transport line.
- c) Thirteen magnetic quadrupoles all 40.6 cm long with 102 mm aperture except the last quadrupole which will be 50.8 cm long with 152 mm aperture. Four quads will be placed upstream of the  $20^\circ$  bend and the nine downstream of the  $20^\circ$  bend.
- d) Two magnetic octupoles 50 cm long and 102 mm aperture. Each of the octupoles will be placed downstream of the  $20^\circ$  bend in order to provide beam shaping and uniformity at the target.

There are provisions for future additional experimental areas which could be serviced by additional beam transport lines branching off at or after the  $20^\circ$  bend.

The optics of the beam transport line has been designed to satisfy the following constraints:

- a) Transport beams having maximum rigidity of 13 T-m.
- b) Transport beams with maximum beam emittances at 95% beam intensities, of  $15\pi$  mm mrad in the vertical plane and  $3\pi$  mm mrad in the horizontal planes. The low upper limit of the horizontal beam emittance as compared with the vertical one, is a consequence of the slow beam extraction from the booster. This small horizontal beam emittance provides additional room to accommodate the horizontal beam size increase

due to the large horizontal dispersion of the beam along the beam transport line.

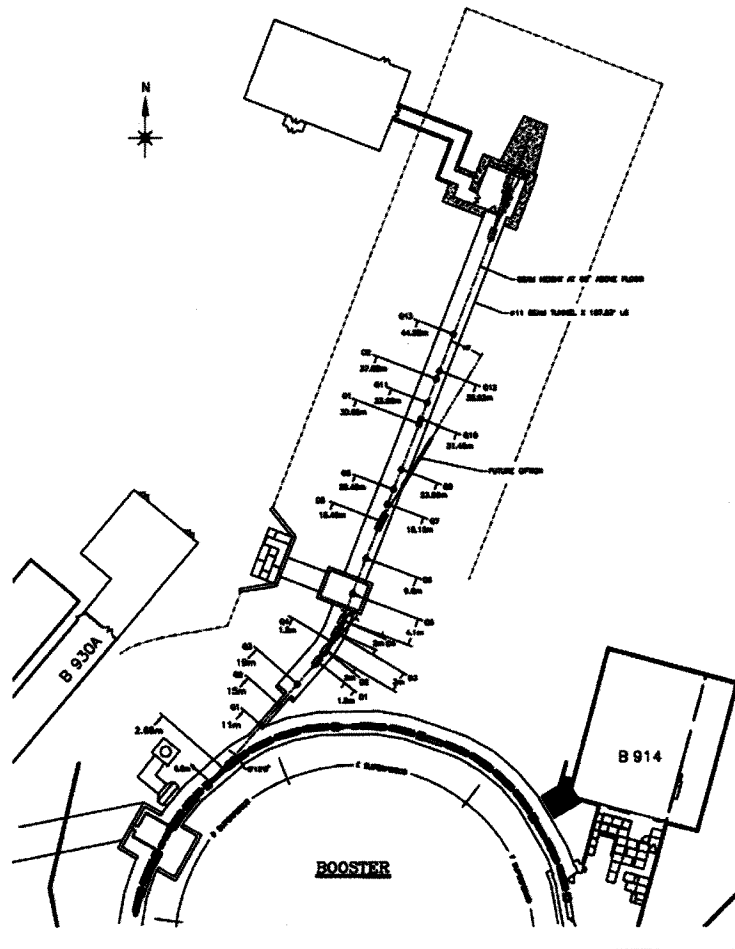

FIGURE 2.6.1 BEAMLINE MAGNET LOCATIONS

- c) To generate variable beam sizes at the target with lower and upper limits of  $\sim 2.0$  cm and 20.0 cm in diameter respectively, for 95% beam intensity and maximum emittances. Beams with lower emittance and/or reduced momentum spread  $dp/p < 0.05\%$  will obviously generate smaller beams on the target.
- d) To generate specified beam parameters (see below) at two points along the beam transport line where each of the octupoles will be placed to provide beam uniformity on the target.

As part of the beam transport calculations, the computation of the beam parameters at the slow beam extraction point (D6) of the Booster was required. This was done by modeling the Booster accelerator ring in the MAD computer code and simulating the third order resonance slow beam extraction. The calculated beam parameters at D6 are shown in Table 2.6.1.

Table 2.6.1  
Characteristics of Beam Transport Source

	Horizontal	Vertical
Emittance	$3 \pi$ mm mrad	$15 \pi$ mm mrad
Beta	10.0 m	4.4 m
Alpha	1.87	-0.67
Dx	30 m	0 m
Dxprime	-3.4	0.0

The beam parameters along the beam transport line were calculated using the computer code TRANSPORT or MAD. The horizontal/vertical beta functions and the horizontal beam dispersion at any point along the beam transport line are shown in Figure 2.5.2. Figure 2.5.3 shows the positive half of the horizontal beam envelope (solid line) and the negative half of the vertical beam envelope (dashed line), both corresponding to 95% beam intensity. Both beam envelopes are confined well within the available aperture of the magnetic elements. For the particular beam optics calculations shown in either Figure 2.6.2 or Figure 2.6.3, the last 2 quadrupoles were set to provide beam on the target with a Gaussian distribution and with 95% of the beam intensity confined in an ellipse having semi-axes of 9 cm for the horizontal and 13 cm for the vertical. The dispersion along the beam transfer line is not constrained by the beam optics, therefore it oscillates to rather large values as seen in Figure 2.6.2.

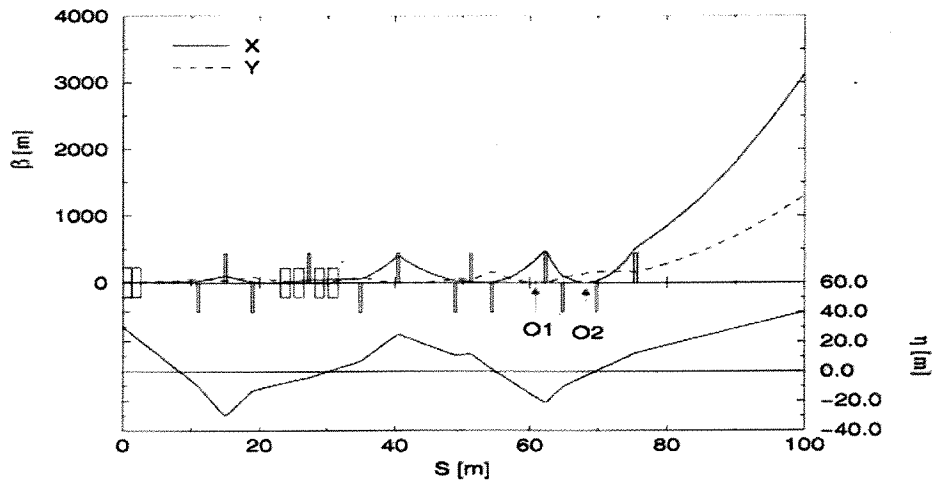

Figure 2.6.2 Optics of the beam transport line.

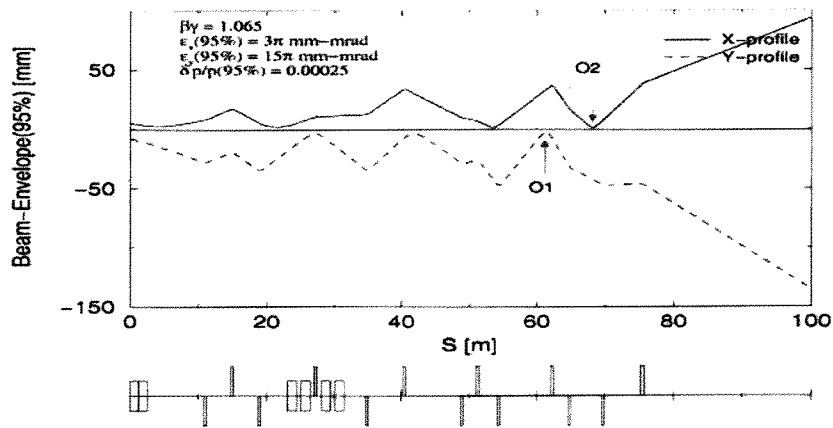

Figure 2.6.3 Beam envelope.

However, this large oscillation of the horizontal dispersion turns out not to be a problem in transporting the beam to the target for two main reasons: First the horizontal beam emittance is smaller than  $3\pi$  mm mrad because of the nature of the slow beam extraction process, thus additional space is available inside the beam pipe to accommodate the beam size increase due to the dispersion. Second the instantaneous momentum spread  $dp/p$  of the beam as calculated from the slow beam extraction simulations is  $\pm 0.025\%$  at

95% beam intensity. During the full extraction process, the beam momentum will vary by 0.5%. This momentum variation of the beam can be compensated by ramping the dipoles so that the central beam trajectory of the extracted beam will always coincide with the symmetry axis of the quadrupoles of the beam transfer line quadrupoles. This change of the dipole strength will only minimally affect the overall optics of the beam line and therefore the shape and size of the beam at of the target.

#### Optics for more uniform beams

The first order beam optics designed in order to allow the placement of two octupoles O1 , O2 (see Figure 2.6.2) which, when turned on, will provide better beam uniformity on the target.

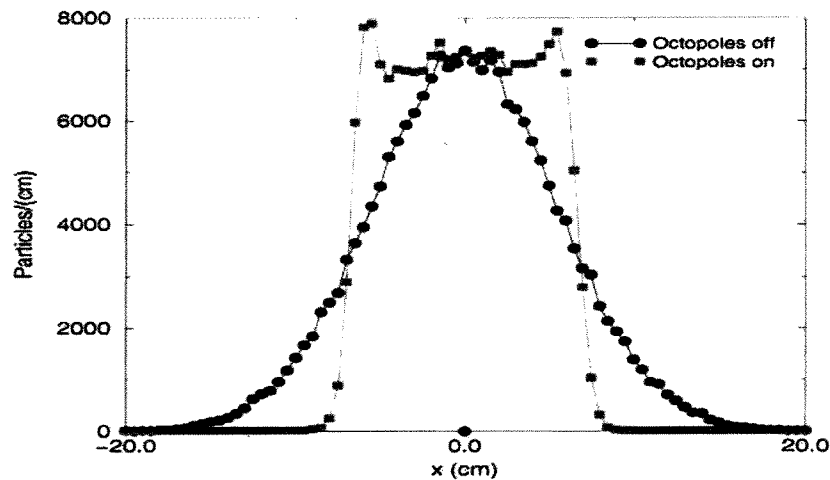

Figure 2.6.4a. Horizontal beam profile at target

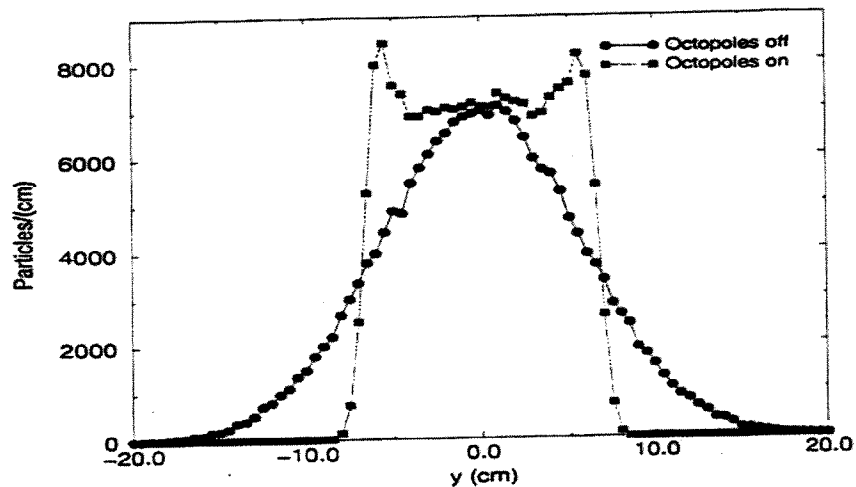

Figure 2.6.4b. Vertical beam profile at target

Indeed when both of the octupoles O1 and O2 of the beam line are turned off, both the horizontal and vertical beam profiles at the target have Gaussian distributions which is shown by filled circles in Figures 2.6.4a and 2.6.4b. The beam profiles correspond to 99.9% of beam intensity, assuming that the beam at the entrance of the beam line is also distributed in a Gaussian fashion. When both of the octupoles O1 and O2 are on, both beam profiles (horizontal/vertical) acquire a rather uniform distribution shown by the filled squares in Figs.2.6.4a and 2.6.4b. The beam on target is distributed over a area of 15 x 15 cm as seen from Figure 2.6.5 which represents a scattered plot of 5000 particles at the target. Beams with rectangular/square cross section at the target of varying sizes from ~7 cm to ~22 cm can be created by varying the strength of the last two quadrupoles and of the octupoles. These calculations are based on beam distributions which are Gaussian at the entrance of the beam transfer line. It is however understood that the horizontal beam distribution may be different. Calculation of the beam distributions on target, using other than Gaussian beam distributions are under way.

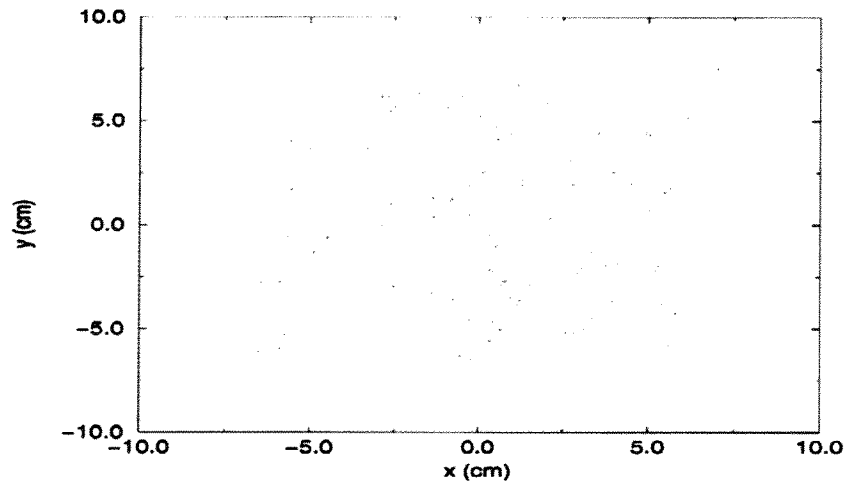

Figure 2.6.5. Beam spot at target.

## 2.7 Beam Transport Elements

### DIPOLES

Four  $5^\circ$  dipole magnets are required to provide the  $20^\circ$  bend after the beam line emerges from the Booster tunnel. These magnets will be of a solid core design to reduce cost. During extraction the magnetic field in these magnets will have to be ramped down to compensate for the momentum spread of the slow extracted beam. The rate of change of the field will be small enough that laminated magnets are not required. The cross-section and specifications for the magnet are given in figure 2.7.1

### QUADRUPOLES

The quadrupole magnets will also be of a solid core design. Both 10.2 cm and 15.4 cm quadrupoles will be required. The 10.2 cm design will be based on the quadrupole magnets designed and built for the g-2 transfer line. The 15.2 cm magnet will have a similar design. The cross-section and specifications for the magnets are given in figure 2.7.2.



SPECIFICATIONS

FIELD, B	10.8 KG
CURRENT	2000 A
LENGTH IRON	127 Cm
GAP	8.3 Cm
POWER, DC	16.8 KW
TURNS	36
CONDUCTOR, RECT.	3.8 x 1.6 Cm, Cu
WATER FL.	25 l/min.
RESISTANCE	.0043 OHMS
VOLTAGE	8.75 V
WEIGHT	4545 Kg

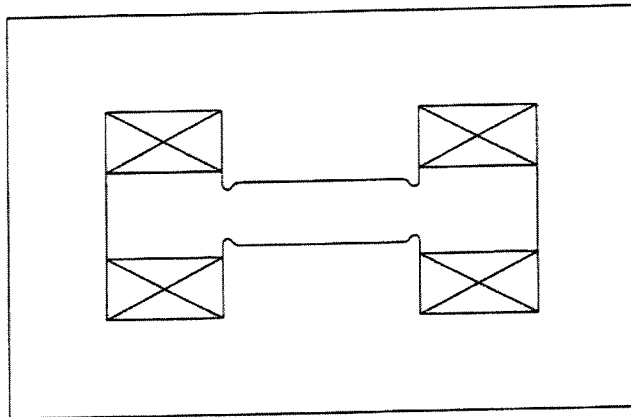

FIGURE 2-7-1 - DIPOLE MAGNET

QUADRUPOLE SPECIFICATION

ø10.2 Cm APERTURE

POLE TIP FIELD, B	6 KG
GRADIENT	1.17 KG/Cm
CURRENT	375 A
LENGTH IRON	40.6 Cm
GAP, DIA	ø10.2 Cm
POWER, DC	2.5 KW
TURNS	34
CONDUCTOR, SQ.	1.02 Cm, COPPER
WATER FL.	4 l/min.
RESISTANCE	.0176 OHMS
VOLTAGE	6.6 V
WEIGHT	477 Kg

QUADRUPOLE SPECIFICATION

ø15.2 Cm APERTURE

POLE TIP FIELD, B	8 KG
GRADIENT	1.05 KG/Cm
CURRENT	750 A
LENGTH IRON	50.8 Cm
GAP, DIA	ø15.2 Cm
POWER, DC	12.5 KW
TURNS	34
CONDUCTOR SQ.	1.02 Cm, COPPER
WATER FL.	18 l/min.
RESISTANCE	.022 OHMS
VOLTAGE	16.5 V
WEIGHT	682 Kg

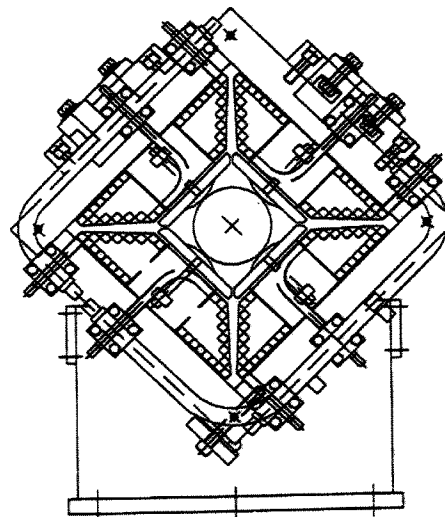

ø10.2 Cm APERTURE

FIGURE 2-7-2 - QUADRUPOLE MAGNETS

## MULTIPOLE MAGNETS

Solid core octopole magnets will be used to flatten the beam as it reaches the target station. These magnets will be similar in design and specifications to octopole magnets used for a similar purpose in the Brookhaven LINAC Isotope Producer facility. The cross-section and specifications for the magnets are given in Figure 2.7.3.

## CORRECTOR MAGNETS

Solid core low magnetic field corrector dipole magnets will be provided to help steer the beam down the line. The magnets will be similar in design to the new correctors which were installed in the AGS last year. These magnets will not require water cooling. The cross-section and specifications for the magnets are given in figure 2.7.4.

## COLLIMATORS

The main collimator for reducing the beam intensity is the radial single jaw collimator located upstream of the D6 magnetic septum. A remotely-actuated four-jaw collimator will be provided for beam shaping. It will be one meter long and will be designed so that the jaws can close completely, thus acting as a beam plug. It will be located upstream of the dipole magnet. The collimator will be designed for ultra-high vacuum and will be capable of high temperature bakeout.

## 2.8 Vacuum System

Because it would cause unacceptable beam loss for low momentum heavy ion beams, a vacuum window can not be used to separate the Booster  $10^{-11}$  Torr ultra high vacuum (UHV) system from the beam line vacuum system. A transition vacuum from the Booster ring vacuum to the line vacuum will be provided. Pressures of  $10^{-10}$  Torr and  $10^{-9}$  Torr will be required in the first two vacuum sections of the line respectively. To accomplish this all parts in the vacuum system will be cleaned and assembled to UHV standards. The first section of the line will be bakeable to  $150^{\circ}\text{C}$ . The rest of the line will be a clean all-metal gasket, unbaked vacuum system with ion pumps similar to the RHIC transfer line vacuum system. Conflat<sup>R</sup> flanges will be utilized throughout the beam line. Non-evaporative getters

### SPECIFICATIONS

POLE TIP FIELD, B	1.5 KG
MAGNET CONSTANT	11.3 G/Cm <sup>3</sup>
CURRENT	100 A
LENGTH IRON	50 Cm
GAP, DIA	∅10.2 Cm
POWER, DC	1000 W
TURNS	16/POLE
CONDUCTOR, SQ.	0.635 Cm, COPPER
WATER FL.	4 l/min.
RESISTANCE	0.076 OHMS
VOLTAGE	7.65 V
WEIGHT	386 Kg

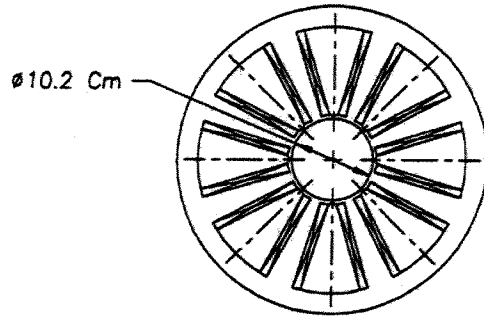

FIGURE 2.7.3 – OCTUPOLE MAGNET

### SPECIFICATIONS

FIELD, B	.204 KG
BL	150 G-M
CURRENT	12 A
LENGTH IRON	73.7 Cm
GAP	10.2 Cm
POWER, DC	160 W
TURNS	146/POLE
CONDUCTOR	# 8 Ga. COPPER
COOLING	AIR COOLED
RESISTANCE	0.92 OHMS
VOLTAGE	13.2 V
WEIGHT	109 Kg

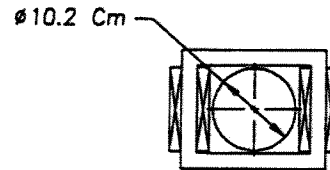

FIGURE 2.7.4 – LOW FIELD CORRECTOR MAGNET

(NEG) which provide high pumping speeds will be used with ion pumps in the first two sections. Ion pumps only will be used for the balance of the line. Cold cathode gauges and Perani gauges will be used for the entire line. Because of the bakeout/UHV requirement, all metal valves with metal sealing gates will be used for the first two sector valves. For the rest of the system, the valves will have viton<sup>R</sup> sealing gates which are significantly less expensive. A fast closing valve will be installed to protect the Booster ring from a catastrophic vacuum failure in the line. The vacuum system includes the costs for the vacuum chambers which are installed in the beam transport system magnets, the cost of the vacuum window at the downstream end, and a ceramic break at the upstream end. It does not cover the cost associated with special chambers for beam instrumentation equipment or the collimators. Also included are the costs for the bakeout blankets required for the upstream end of the line, wiring in the bakeout blankets, the costs for additional heater relay boxes, computer modules, updating the bakeout computer control software, testing the system, and doing the final bake out. A listing of the vacuum equipment required is given in table 2.8.1 and individual locations are shown in figure 2.8.1.

TABLE 2.8.1  
INVENTORY OF MAJOR VACUUM COMPONENTS

<u>DESCRIPTION</u>	<u>QUANTITY</u>
Bellows 6" conflat <sup>R</sup> x 4" id	47
All metal gate valves	2
O-ring gate valves	2
Quadrupole spool pipes	15
Heater blankets	31
20 liter ion pumps	2
150 liter ion pumps	8
750 liter NEG cartridge	2
NEG pipes	4
Turbo molecular pump roughing stations	3
Ion pump power supplies	5
NEG power supply	2
PUE chamber	1
Vacuum system support stands	42
Residual Gas analyzer	1
Helium Leak Detector	1
Gauge controllers w gauges	5
6" conflat <sup>R</sup> x 4" tube spool pipes	19
Pump tees	10
Fast closing valve & controller	1
Window assembly	1
Roughing valves	8



Section 2.3. Since the deflection angle is large, the field and hence the current have to exhibit high stability and reproducibility both short term as well as long term, the requirement is typically better than 1 part in the 10,000. The septum magnet has a fairly low inductance, therefore the PS design, in addition, has to produce very low voltage ripple. The two designs considered are a multiphase thyristor type with a ripple filter, or a dc supply equipped with a series transistor bank regulator. Since the thyristor unit requires very good balance between phases initially, and produces higher values of ripple when the output is reduced, it produces less desirable results when phased back. The series transistor bank on the other hand can do an excellent job both in switching the system ON/OFF, and in regulating and filtering the output current and voltage over a wider range. A crucial part of the design of the ejector PS system is the minimization of the interconnecting bus or cabling system length. This not only has significant cost considerations for the cable, but it also improves reliability and reduces the power rating of the regulating transistor bank. Thus, the distance between the PS and the Booster D6 straight section has to be made as short as possible. A fast resistance interlock chassis will be used to protect against septum overtemperature.

The D3 electromagnetic thin septum PS must operate at currents up to 1000 amperes under pulsed or dc conditions. The design of this system will be similar to thin septum units already in use in the AGS slow extracted beam. The high current dc source will be a standard commercial module that is rated for the full output current. The control & regulation will be accomplished by a series transistor bank of same basic design as the AGS units. It will be interfaced to the control system via a device controller and a waveform generator card. The control of the PS functions will be via a programmable logic controller or PLC. The current will be fed to the septum, via a set of high current cables in parallel. The thin septum will be protected against overtemperature by fast, resistance-measuring comparators which are calibrated to the maximum allowable temperature rise in the septum and backleg turns.

The two sextupole power supplies will be pulsed units that turn on when the Booster enters the flattop part of the heavy ion cycle. They will be pulsed for approximately 1 second and create the third-integer resonant condition for the beam to be efficiently extracted. The rise time will be about 50 msec and the flattop will be well regulated in order to minimize spill ripple. During the Booster acceleration phase they will be used to control the chromaticity of the machine by tracking the other 20 Booster horizontal sextupole magnets.

The requirements for the resonance sextupole PS's can be met by a multiphase thyristor (silicon controlled rectifier, SCR) together with a passive filter, and by a series regulator transistor bank, or by a high frequency switching type PS. In both cases the unit will be current regulated and will have an accurate current sensor of the DCCT type for current regulation and measurement. The unit will be interfaced to the control computers and will have a function generator reference program. It will be capable of peak currents of 700 Amperes. The P.S. controls will be accomplished by a PLC. The four (4) sextupoles that will be used to generate the  $1/3$  integer resonance for extraction will be normal chromaticity Booster ring sextupoles that will be pulled out from the series string and connected to their own individual PS's. These supplies will be programmable so that they can service the dual function of Booster chromaticity control during injection/acceleration and Booster extraction.

Due to the relocation of the internal beam dump, the existing orbit deformation magnets (backleg windings) for this purpose have to be rewired to encompass the B6 region.

The two (horizontal and vertical) tune trim control power supplies, which power trim windings on the Booster main quadrupoles have to operate at higher currents (1000A instead of 700A) to track the beam momentum, and to bring the horizontal tunes to the  $13/3$  value required for the resonant extraction. Thus, new supplies have to be purchased and the series strings have to be recabled.

#### Orbit Bump PS's

An orbit bump centered around the thin septum (D3) and the ejector septum (D6) is required in the Booster lattice to enable slow extraction. The bump enables the maximization of Booster injection aperture at the septa regions. The bump PS's, of which 2 are high current and 2 are lower current, will be dc power supplies with series regulated transistor banks with PLC and waveform generator controls.

All in-ring P.S.'s will be water-cooled to reduce the power loss to the building and hence requiring a larger A/C system.

The Booster Main Magnet Power Supply (MMPS) is a flexible, programmable unit which can generate the cycles required by the BAF. A set of typical cycles is shown in Figure 2.9.1. As can be seen in the Figure, the Booster can operate in a dedicated fashion for the BAF, or in a



mixed fashion serving the AGS and the BAF. At the peak current (flattop) of 5 kiloamperes, corresponding to the maximum heavy ion energy, the Booster MMPS ratings ( $\sim 4\text{kA}$ , rms) must not be exceeded. In order to stay within the thermal rating of all the equipment required for slow extraction the duty factor at full energy (corresponding to a beam rigidity of 17 T-m) needs to be limited to 1/3.

### Beam Transport Power Supplies

The beam transport line for the BAF requires a relatively large number of quadrupoles to accommodate the transport of the Booster slow extracted beams to the  $20^\circ$  dipole area and then to the target building. In terms of large dipoles, a large bend of  $20^\circ$  has to be provided. In addition, a number of trim dipole and octupole magnets are provided to control the position, size, and uniformity of the beams.

The P.S.'s for all these elements are conventional types which will be built similar to many units previously purchased at the AGS or for RHIC injection.

The PS's for the above magnets will basically be ac to dc converter types. They will consist of SCR bridges and passive filters. A sensitive, accurate DCCT type current sensor will be incorporated in the designs, to both measure and regulate the output using feedback. The ac controls will be based on programmable logic controllers (PLC's) for control, protection

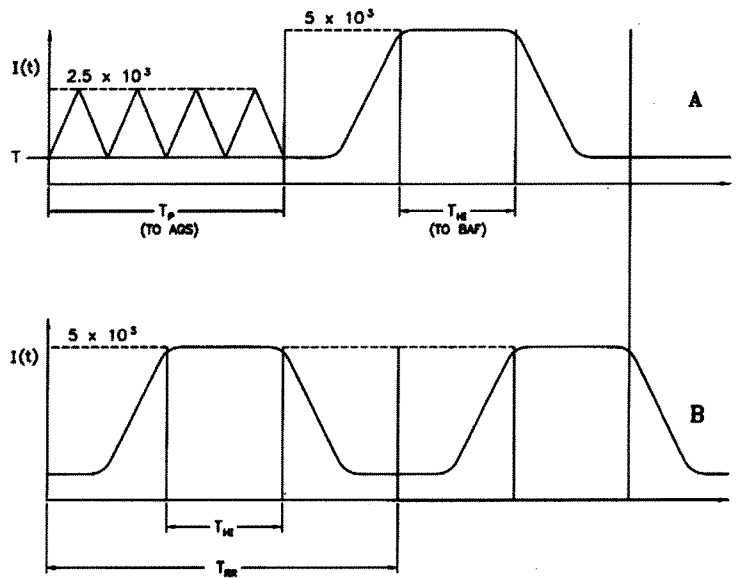

**TYPICAL AGS BOOSTER CYCLES**

- A) Sequential Operation AGS/BAF
- B) Dedicated Operation for BAF

Note:  
 $I_p \leq 5 \times 10^3$  A  
 $T_m / T_p < 1/3$

**Figure 2.9.1 TYPICAL BOOSTER MAGNET CYCLES**

and interfacing of the units to central AGS computers. All the PS's are listed in Table 2.9.1 and will be purchased commercially via competitive bidding to BNL generated specifications.

The trim PS's will be low power bipolar types since the output trim current and polarity are not known apriori. They will be designed to provide smooth current control through zero current. Units will be similar to other steering supplies that are used in the AGS.

Magnet monitoring and protection will be included. The transport PS's will be water-cooled, with a total requirement of 60 gpm, to remove the large requirement of building heat loads.

Table 2.9.1  
Beam Transport System Power Supplies

Load	Quantity	Description
Quadrupole	12	40 V x 500 A, 20 kW
	1	45 V x 700 A, 30 kW
20° Dipole (Dipoles in Series)	1	50 V x 2000 A, 100 kW
Octupole	2	20 V x 250 A, 5 kW
Trim Dipole	4	±40 V x 15 A, 600 W

#### 2.10 Controls

The distributed control system will provide the infrastructure elements which interconnect the several equipment locations associated with the BAF project.

The existing AGS/RHIC Controls Ethernet will be extended to the following three equipment locations:

- Tandem - MP6 Beam-line Area
- Booster Extraction & Beamline Equipment Area
- BAF Beam-line Control Room

A switch chassis will be provided between the Ethernet and the AGS/RHIC backbone (100 Mbit Ethernet). Standard AGS/RHIC VME Front-End chassis with processors and utility modules will be provided for controls interfacing. Fiber-optic (f/o) transceiver units and hubs will be used for Ethernet distribution.

Standard AGS/RHIC timing and link equipment will be required in the equipment locations, for the delivery of standard Booster clocks and event signals. This equipment will include f/o transceiver chassis and modules, fanout/repeater modules, and VME decoder/delay modules. Upgrade of central Booster timing generators will be required for compatibility with current AGS & RHIC units.

BAF equipment areas will be connected by f/o cable with the AGS Control Room

(Building 911) for Ethernet, timing and links. Module interconnect cables and equipment enclosures will also be provided.

Computer resources will be provided for the console-level access to the control system. Software engineering effort will be required for database and program development, at both front and end console levels.

Additional workstations will be provided for the Tandem control room and for BAF software maintenance. A server will be procured to service the additional load on central facilities. X-terminals will be placed at equipment locations and in the beamline control room.

Front-End controls interface equipment will be provided for the various sub-system elements.

At the Tandem beam line, a field-bus controller will be needed for power supply interfacing. A new instrumentation interface will be provided for profile monitors, beam current transformers and Faraday cups. An interface for vacuum system valves and gauges will be required.

Standard RHIC/AGS waveform generator power supply interfaces (waveform generators, PLC interface, and MADC system) will be required for the following systems:

- Drive Sextupole Power Supplies
- Tune Quadrupole Power Supplies
- Orbit Bump Power Supplies
- Septum Power Supplies
- Spill Servo Reference

A stripper-foil control interface and motor drive controls for the thin septum positioners will be provided.

Standard PS interfaces will also be used for the beam-line magnet power supplies. A PLC interface module will be provided for vacuum system equipment, along with a RHIC standard VME stepper motor controller for collimators. Instrumentation interfaces will include a VME scaler for SEC/Ion Chamber data acquisition, a flag interface system (frame-grabber) and a standard AGS SWIC interface using a VME MADC.

## 2.11 Beam Instrumentation

### Spill Servo Detector

An ion chamber in the extraction line serves as the detector for the Spill Servo described in Section 2.4. The retractable chamber can be located near the start of the beam line and is removable if necessary. In normal operation, the ion chamber will be used to generate a correction waveform, or the chamber is retracted and the system is run open loop using the derived correction signal, which is stored. Alternatively, the correction signal, could be derived from the experiment user's equipment or a loss monitor detector sensitive to the ejector septum magnet loss.

### Beam Intensity Monitor

An ion chamber, similar to that for the Spill Servo, is used as the downstream beam line intensity monitor. The output of the spill servo ion chamber will also provide the intensity of the beam extracted from the booster.

### Profile Monitor

Beam profiles provide several types of useful information. By varying an upstream quadrupole, a properly located profile monitor provides a measurement of the beam emittance. This allows calculation of the beam transport parameters down the extraction line. Observation of the profile near extraction shows the effects of scraping on the septum and position information is obtained from the centroid of the profile.

The profile monitor used in the AGS to RHIC transfer line is based on measuring the light emitted from a phosphor screen hit by the beam. These detectors, or Flags, have been used since the early days of accelerators. Advances in video cameras and image processing software and hardware have made this a viable quantitative technique. Three detectors will be located upstream of the 20° bending magnets, with an additional Flag in the experimental line, for a total of four units. Beam profiles will be available numerically through the control system as well as 2D and 3D pseudo color contour maps. An image intensifier will allow extension of the range by a factor of 1000 for very low intensity beams.

## Segmented Wire Ionization Chamber

Beam profiles can also be obtained using a Segmented Wire Ionization chamber (SWIC). Three SWICS are distributed at locations in the extraction beam line, downstream of the collimators. The SWIC assemblies are retractable and will be plunged into the beam path when profile data and when beam centroid information is required. As the beam passes through the SWIC, a gas is ionized and the charged particles are directed by a bias voltage to detectors connected to integrator electronics. A SWIC has the ability to resolve profiles of various intensities depending on the bias voltage. SWIC's are presently used in the AGS extraction beam line for similar applications. They extend the ability to acquire profiles for intensities below the capabilities of the flag system. The resolution of the data provided by the SWIC (wire spacing 2mm) will not be as high as the flag system. Digitizing hardware similar to those currently in use at the AGS, will process profile data using software to approximate full-width half-maximum and emittance measurements.

### 2.12 Experimental Area Design

#### Radiobiology Research Considerations Relevant to the Facility Design

As a national facility being prepared for research in the diverse field of biological effects of high-Z, high-E (HZE) particles, BAF's design will be broad and diverse to allow pursuits of a variety of aspects of the subject. At the same time, the facility will be capable of answering, in the long run, the most basic question in this field, i.e. the risk to humans in different shielding environments from exposure to ionizing particles in the galactic cosmic rays (GCR). Although the effect of HZE particles on living organisms seems to be too complicated to be amenable to computer simulation for risk assessments in different environments, the task is achievable because the effect can be divided into four simpler components that can be studied independently. These four components, as described below, are in four different scientific disciplines: 1) nuclear physics, 2) atomic physics, 3) molecular/cellular radiobiology, and 4) physiologic tissue/organ radiobiology, respectively.

#### 1) Nuclear physics.

Nuclear fragmentation and other nuclear interactions of HZE particles with matter.

2) Atomic physics.

Ionization-density profiles produced around the track of individual primary or secondary particles.

3) Molecular/cellular radiobiology.

Biological effects of ionizations at the densities produced by HZE products, usually studied in vitro at the molecular or cellular level. The dosimetric models available are bounded by two extreme cases in which: i) the RBE model (high particle fluence, low-to-moderate linear-energy-transfer (LET) particles, many hit sites per cell); and ii) the single-hit model (low fluence, high-LET, for a population of individual cells exposed to a particle beam). The single-hit model is more appropriate for galactic-particle exposures.

4) Physiologic tissue/organ radiobiology.

Response of the integrated biological systems to radiations, studied in vivo.

Items 2 and 3 are discussed in more detail later in the text.

Unless these four scientific disciplines are studied independently over large ranges of parameters that appear in the actual HZE-particle interaction with living tissue, the various feasible configurations cannot be adequately simulated. As an example, in vivo studies with a single animal with a single beam does not bring us closer to the risk answer, unless it is one component among a well-planned, large set of experiments that span all four related subjects. For this reason, emphasis has been placed on the design of the BAF to allow independent studies of these processes. The special provisions made for this purpose are discussed below.

#### Design Considerations for Fine Beam Parameters

Another major consideration in the conceptual design of the facility is to allow high-precision irradiations by providing "clean" beams i.e., a single ion with a narrow beam-energy width, free of neutrons and charged-particle fragmentation products and beams in a wide range of diameters. For this purpose the basic beam parameters, i.e. beam energy, beam intensity, beam-profile flattening, and beam diameter, will all be adjustable within the Booster or in the

beam transport line with a wide dynamic range for each parameter. Therefore the design does not include any compensators for beam energy or beam profile, or any mechanical collimators or absorbers beyond the last bending magnet. In particular, the beams will have the following properties:

- 1) Beam energy will be tunable over a wide dynamic range, see Section 2.3.
- 2) Beam profiles will be flattened with octupole magnets with no beam trimmers past the last dipole magnet, see Section 2.6.
- 3) Beam intensities will be tuned at two stages. First, the optimum ion source parameters at the Tandem Van de Graaff will be used for the upper range of beam intensities. Second, the intensity will be selected at the transport lines using charge-state selection by deflection in the magnetic field of the dipoles.
- 4) Beam diameters will be adjusted by multipole-magnet beam shaping. The beam diameters can be as large as 15 cm.

#### Design of the Target Room

Design of the target room is shown in Figure 2. 1.2.

The following considerations have been used in the design of the target room and target holder to avoid beam contaminants interacting with the targets.

- a. Cutoff of the beam will be accomplished by turning off the extraction power supplies.
- b. A deeply recessed and well-shielded beam dump at the end of the target room will prevent fragment products and backscattered particles from reaching the target.
- c. The beam dimensions will be adjusted to the target to minimize interaction of the beam with the target holder. If a target backing is necessary (like the backing of the cell-culture



targets) the backing will be made with the lightest materials possible.

Other features of the target room, introduced to facilitate the experimental work, are the following:

- a. Entrance to the room is gained through a maze. Therefore entrance to the room after the completion of irradiation requires only opening of the interlocked safety partition and not any heavy shielded doors.
- b. The target holder will be positioned by stepping motors controlled by the computer. Video cameras will allow monitoring of the process from outside the target room.
- c. The target room is conveniently connected to the support laboratories (Figure 2.1.2), as described in the section below.

#### Design of the Support Laboratories

As it is shown in Figure 2.1.2, the corridor from the Target Room is connected with the central hall leading to all support laboratories. The Laboratory Support Building has been designed to maximize use of beam time and facilitate experimental design and execution. All experimental rooms will access the maze leading to the target area via a central corridor. A dosimetry room will contain dosimetry computers, and will communicate electronically with both the AGS control room and the user experiment rooms. Two rooms are provided for both the cellular experiments, and for animal studies; allowing one group to set up samples in an experimental area while the previous group uses another experimental room, concludes their experiments in an ordered fashion, and takes all necessary time points. To comply with regulations for maintenance of animal facilities, a wash facility is provided off a side corridor onto which the animal experiment rooms also open. A janitor's closet is provided for storage of cleaning equipment and supplies. A biophysics/physics/electronics experiment room allows studies of effects on materials and electronics. Two wheel chair-accessible rest rooms are accessed from a side corridor. A user room is provided for the investigators before and after beam use. To minimize cable

length, the physics control room and physics/electronics experiment rooms are in proximity to the gate leading to the maze. Two service entrances are provided with drive-up access and overhead shelter to allow off-loading of experimental samples and equipment in all weather conditions.

#### Provisions for Studying the Four Scientific Disciplines

The capability to measure the fragmentation properties of heavy ion beams at BAF will be needed both for beam characterization for radiobiology [1] and for physics studies of heavy ion fragmentation and transport in matter [2-3]. In particular, data are still needed to refine and validate models of heavy ion fragmentation and transport [4], critical to the design of cost-effective shielding for manned interplanetary spaceflight.

For beam characterization measurements, a small angle solid state detector telescope, similar to that described in Ref. [1], would be adequate. Such a device could also be used to study fragmentation physics near the beam axis. For more detailed measurements, such as multi-fragment final states and angular distributions, a large solid angle general purpose spectrometer such as the EOS TPC or ALADIN (GSI) would be appropriate. Single charge resolution is highly desirable, as is the capability to distinguish multiple fragments; isotopic resolution is not needed for shielding studies, but would be useful for astrophysics applications. It would also be desirable to include detectors for fast neutrons, which are a significant component of the GCR-induced radiation dose behind shielding.

#### Microdosimetry

Microdosimetry measurements provide ionization density as a function of the distance radially outward from the particle track (N.F. Metting, et al. Microdosimetry near the Trajectory of High-Energy Heavy Ions. *Radiat. Research* 116, 183-195, 1988), and for populations of cells exposed in a particle field. The sharp fall of the density with radial distance (typically 3-4 orders of magnitude in 3-4  $\mu\text{m}$  distance from the core of the track) requires spatial resolution of the order of micrometers in the detection system. Basic requirements of the facility are a primary beam free of beam contaminants with a narrow beam energy width and a uniform and stable beam intensity adjustable over a wide range,

all of which are satisfied by the BAF beam design. The single-hit model will be used, investigating dosimetric concepts such as effective lethal dose and cell survival (D.T. Goodhead, et al., Mutation and inactivation of cultured mammalian cells exposed to beams of accelerated heavy ions. IV. Biophysical interpretation. Int. J. Radiat. Biol. 37, 135-167, 1980), and hit size effectiveness function (HSEF) (C.A. Sondhaus, V.P. Bond, and L.E. Feinendegen. Cell-oriented alternatives to dose, quality factor, and dose equivalent for low-level radiation. Health Phys. 59, 35-48, 1990).

#### Molecular-cellular radiobiology

Because of the high purity of the beam, it is essential that the backing of the cell-culture targets be as light as possible, to minimize production of secondary particles. A target wheel holding several targets simultaneously will be allowable only if the above requirement is fully satisfied.

Primary goals of research in biological and physical sciences at the BAF will be evaluation and estimation of risk from space particles and their fragmentation products to long term space travelers and to mission-critical components. A hierarchy of biological systems will be used to study a number of genetic and cellular endpoints, constituting a broad range of quantifiable endpoints from the molecular to the integrated tissue level. Biological research will encompass studies of neurological effects, cellular and molecular alterations, including changes in DNA, in the cell matrix, and their short and long term consequences, as well as measurement of *in vivo* and *in vitro* oncogenesis. Various model systems, especially those with well-defined genetics, will also be utilized. Both the effects of space particles, and of their fragmentation products will be studied. Physical measurements will provide beam characterization and dosimetry for all experiments, and will also include studies of heavy ion fragmentation and transport in matter as well as the effects of space radiation on electronic components and circuits.

Animal care and use for *in vivo* studies at BAF. Animal studies will be facilitated by the existing high quality, AAALAC accredited Laboratory Animal Facility located in the BNL Medical Department. The total net area of the primary animal facility is ~14,000 sq.ft. of which ~7,000 sq.ft. are used for housing animals. Most animal rooms are on a

clean/dirty corridor system. In addition, there are 4 large rooms (400 sq.ft. each) with separate entry facilities and supplied by once-through, HEPA-filtered air, that can be used in as semi-barrier suites for long-term housing of post-exposure animals. Other long-term housing facilities include a complete barrier room and a laminar-flow room. All relevant support areas including quarantine, surgery, necropsy, radiology, and clinical pathology laboratories are available.

### 2.13 Shielding

The primary purpose of the shielding design is to provide safe radiation levels in the support building and the area around BAF which is generally accessible and the target area and tunnel. Access to the target area and tunnel is controlled by the security system (see Section 1.14).

The primary shielding material is concrete at the target area and beamstop. Earth shielding will be added to the target area on the tunnel to a depth of 15 feet. Additional shielding is provided by a concrete beam stop at the downstream end of the target. The beamstop is approximately 26 feet long. An advantage of the concrete beam stop is that any induced radioactivity produced in the adjacent soil-water will be less than the Drinking Water Standard for radioactivity. The laboratory has indicated it wishes to meet this standard, which is more restrictive than the ALARA Guideline of DOE order 5400.5. Thus, water in the ground even at the interface to the facility will meet the same requirements as tap water. The labyrinths are designed to reduce radiation in the support building to well below 0.25 mrem/hr which is the DOE design limit for continuously occupied areas.

The shielding will reduce skyshine to much less than the allowable DOE design levels. Radiological areas will be appropriately controlled with posting and/or fencing. Estimates of radiation levels in various regions based on given loss events are shown in Table 2.1.3. The basis for the estimates is a formula derived by Tesch\* and coefficients from Ban† for lateral dose equivalent, all losses are point source and the formula was adjusted for most likely angle from the source point.

---

\* Tesch, Health Physics 44, 1, pp 79-82, 1983

† Ban, et al., Nuc. Inst. And Meth., 174, pp 271-276, 1980

TABLE 2.13.1 Estimated Radiation Levels

Loss Location	Source (5 GeV per nucleon)	Level	Comment
BAF Collimator	Planned $10^7$ nucleons/pulse	$10^{-5}$ mrem/h	1.3 ft iron, 15 ft earth. Dose rate on top of berm. Radiation monitors turn beam off. Dose to person outside of beam collimator area.
	Fault $1.5 \times 10^{14}$ nucleons/s for 9 seconds	3.7 mrem	
Target Room	Planned $10^{10}$ nucleons/pulse	0.3 mrem/h	4 ft concrete, 11 ft of earth. Dose rate on top of berm.
	Fault $1.5 \times 10^{14}$ nucleons/s for 9 seconds	1.3 mrem	4 ft concrete, 16 ft of earth at beam height. Radiation monitors turn beam off. Dose to person outside of target building.
	Planned $10^{10}$ nucleons/pulse	0.3 mrem/h	Labyrinth entrance to laboratory.
	Brief planned excursions at $10^{11}$ nucleons/pulse	3 mrem/h	Labyrinth entrance to laboratory. Essentially three labyrinth legs, cross-section is 48 ft <sup>2</sup> .
	Fault $1.5 \times 10^{14}$ nucleons/s for 9 seconds	34 mrem	Labyrinth entrance to laboratory. Essentially three labyrinth legs, cross-section is 48 ft <sup>2</sup> . Radiation monitors turn beam off. Dose to person standing at labyrinth entrance.
BAF Beam Stop	Planned $10^{10}$ nucleons/pulse	0.01 mrem/h	6 ft concrete, 15 ft of earth. Top of beam stop.
	Planned $10^{10}$ nucleons/pulse	0.005 mrem/h	6 ft of concrete, 16 ft of earth at beam height. Side of beam stop.
	Fault $1.5 \times 10^{14}$ nucleons/s for 9 seconds	1.3 mrem	6 ft concrete, 15 ft of earth. Top of beam stop. Radiation monitors turn beam off. Dose to person standing at top of beam stop.
	Planned $1.5 \times 10^{16}$ nucleons/year at 5 GeV or equivalent	Less Than Drinking Water Standards	Annual burden of nucleons on beam stop. The concern is rainwater that percolates through soil near the beam stop.
BAF 20° Bend	Fault $10^{10}$ nucleons/pulse	0.1 mrem/h	Planned incremental beam (1 hour average) inadvertently strikes bending magnets at 20° bend, 0.75 ft iron, 15 ft earth
	Fault $1.5 \times 10^{14}$ nucleons/s for 9 seconds	11	Maximum instantaneous beam inadvertently strikes bending magnets at 20° bend, 0.75 ft iron, 15 ft earth. Radiation monitors turn beam off. Dose to person standing at top of berm.

## 2.14 Personnel Safety System

An efficient and cost effective approach to the access controls implemented in the Booster Applications Facility (BAF) is to extend the present relay-based Booster system to these external areas. Requirements for this facility follow established AGS Department guidelines for limiting and controlling 1) personnel access to beam enclosures, and 2) possible prompt radiation concerns in adjacent areas. No provision is presently included in this system for control of any electrical hazards.

A brief summary of the access controls follows, see Figure 2.6.1 for layout of beamline.

1. Personnel access gates: 3 initial, (1 additional possible).
  - 1.1 Labyrinth entrance from the beamline shield (plug) door, (standard gate).
  - 1.2 Labyrinth entrance from the experimenter's laboratory building, (standard gate).
  - 1.3 Internal gate at the upstream end of the experimenter area, (isolation gate).
  - 1.4 [possible] Internal gate at the upstream end of the initial beamline, (isolation gate).

Standard Gates 1.1 and 1.2 would be normal external access gates and be instrumented and interlocked to disable BAF extracted beam. Isolation Gate 1.3 would allow unrestricted egress from the BAF tunnel into the experimenter area but require (in some control configurations) a Controlled Access (CA) key and simultaneous release from the AGS MCR for movement from the experimenter area to the BAF tunnel. The Isolation Gate noted as Gate 1.4 above may prove useful to isolate the BAF tunnel proper from the beamline segment contiguous with the Booster penetration. A small shielding labyrinth has been suggested in this region to mitigate beam loss at the D6 straight section tangent to the Booster ring. If this gate were to be installed, it would be fully instrumented and interlocked to the Booster injected beam for both the Linac and TVDG.

### 2. BAF beamline shield (plug) door

The beamline shield (plug) door need not be moveable. This personnel labyrinth will be designed to allow beamline access for large common usage items (e.g. vacuum leak

checking station). As part of the labyrinth specification, the engineering staff will define equipment access needs and associated physical dimensions of the labyrinth. If larger elements must be removed and/or installed, the overhead of removing and re-installing this shield wall would not contribute much to the BAF downtime required for the beamline equipment access. As noted earlier, if the Isolation Gate 1.4 is installed, access to BAF areas downstream of this gate may be permitted once fault studies confirm that prompt radiation from the Booster ring does not present a hazard.

### 3. Initial definition of the critical devices

Critical defines are those (usually) beamline elements chosen such that when they are placed in a SAFE state (usually OFF or CLOSED), the prompt radiation hazard to downstream areas is either 1) reduced below guideline limits to safely permit access, or 2) essentially eliminated. As with other aspects of a personnel safety system, AGS guidelines require two separate (dual-redundant) critical devices be defined for each area to allow access. Each of these critical devices must, by itself, sufficiently mitigate the prompt radiation hazard to meet either of the goals stated above.

#### 3.1 Disable BAF beam = D6 Septum, D3 Septum, D6 Extraction Bumps

Any two of these devices (given that the four D6 Extractions bumps = 1 "device") are required and would likely be adequate to disable the extracted BAF beam. The BAF beamline element DH1&2 (20° bend) is not identified as a critical device since there is neither shielding nor another bend between these dipole magnets and the experimenter area.

#### 3.2 Gate access critical devices.

3.2.1 Access through any one of Gate 1.1, 1.2 or 1.3 will disable the Booster extracted beam to BAF.

3.2.2 Access through Gate 1.4 will disable the Booster injected beam from both the Linac and TVDG.

#### 4. Sweep Zones

Before permitting beam into any beamline, the AGS MCR Operations group must ensure that the beamline enclosure is cleared of personnel. This is accomplished by a search of the area followed by an area reset; placing the enclosure into controlled, access prohibited state. Also, in order to limit the scope of this sweep for personnel and reduce the need to unnecessarily sweep adjacent areas, most beam enclosures are limited in physical size. For the BAF beamline, it is proposed to have three sweep zones. It is recommended that each zone be instrumented with reset stations appropriately located to focus attention during the sweep in locations of limited line-of-sight. These reset stations could also be integrated into a sequential sweep scenario if desired. The extent of each of these zones is defined below, (ref. Beamline Layout, Figure \*.\*);

4.1 Sweep Zone #1: From the Booster ring penetration to the end of the BAF tunnel internal labyrinth at Isolation Gate 1.4. [This area would be required to be swept and reset in order to allow beam into the Booster ring.

4.2 Sweep Zone#2: From the BAF tunnel internal labyrinth Isolation Gate 1.4 to the Isolation Gate 1.3 between the downstream BAF tunnel and the experimenter area. Access to this area may be permitted with the BAF extracted beam disabled but with beam in the Booster ring, (to be determined by fault studies).

4.3 Sweep Zone#3: From the experimenter area Isolation Gate 1.3 to the end of the labyrinth leading to the experimenter's laboratory building, (Standard Gate 1.2). Access to this area may be permitted with the BAF extracted beam disabled but with beam in the Booster ring, (to be determined by fault studies).

#### 5. Equipment:



- 5.1 There will be two (dual) "positive action" position sense switches mounted at each gate. "Positive action" switches are designed such that switch motion is forced and monitored for both the OPEN and CLOSED positions.
- 5.2 Each gate will have one electric strike. In Controlled Access (CA) mode, the electric strike must be energized from the MCR in order to access the area.
- 5.3 A means of emergency egress through these gates will be provided, such as the standard emergency CRASH glass on AGS style gates. This glass will be monitored and provide a beam interlock if not intact.
- 5.4 Installing reset stations internal to the BAF tunnel is recommended; placing one or more units in each of the three defined sweep zones.
- 5.5 CRASH stations would be required along the BAF tunnel. Use of either individual CRASH actuators and/or distributed CRASH cords should be determined on the basis of ease of access to these devices and whether they might be inadvertently activated due to their locations. [Activation of any CRASH immediately disables the beam to the area].

## 6. Access states:

- 6.1 Restricted Access (RA): Applies to all BAF enclosure gates and does not require a key for access. Appropriate hazard and training requirements will be posted.
- 6.2 Controlled Access (CA): For Standard Gates 1.1, 1.3 and 1.4, a unique CA key PLUS simultaneous release from MCR for access. Control and tracking of those entering the area would be done by MCR Operator assisted log in/log out access.
- 6.3 Controlled Access (CA): At Standard Gate 1.2, use of a key tree system for CA should be investigated. This would require all of the following to be true;

6.3.1 Video surveillance at this gate with clear representation in the MCR.

6.3.2 A simultaneous release (MCR deliberate action and local deliberate action at the gate) is required. [For this option to be permitted, MCR must also have immediate access to a means of identifying those requesting access (e.g. a rogues gallery of pictures or scanned pictures into a PC) as well as the current training database. This is essential for tracking the number of persons in/out as well as ensuring that each person has the appropriate training for access.

## 7. Other system devices:

The BAF beamline and experimenter area will have sufficient shielding to adequately reduce or eliminate any prompt radiation levels outside of these areas due to normal and fault conditions. However, there may be a need to provide active monitoring in the upstream BAF beamline to monitor beam losses in the BAF extraction region of the Booster ring. This can be accomplished using two (dual-redundant) interlocking Chipmunks. These devices have a ~ tissue equivalent response to the observed prompt radiation that could be found adjacent to AGS facilities. These devices would interlock the Booster injected beam should significant Booster proton beam loss be noted in this area.

## 2.15 Services

### Electrical Distribution

Power distribution to ring and transport line magnet power supplies is required within the power supply house enclosure. Local 480 volt branch circuits will be installed via appropriate disconnects from the panels installed during conventional construction. Distribution of 208/110 volt services within the power supply house for control and instrumentation purposes is also required.

Within the beam transport tunnel power for locally operated instrumentation and controls is required, as is additional high current, intermittent service to be utilized for the activation of the getter strip vacuum system. Outlets will be distributed regularly throughout the tunnels for operation of turbopump roughing systems. Local power distribution from pre-installed power

panels is required both within the experimental caves as well as some areas of the support building. Power capacity installed within the target areas must be sufficient to provide levels of power for a wide range of experimental equipment.

#### Cooling Water

Deionized water is required for coolant to both magnet loads and their power supplies. A dedicated magnet cooling system will be provided for the BAF facility beam transport tunnels, the experimental chambers and to the power supply house which accommodates the magnet power supplies. Approximately 300 GPM at a pressure differential of 100 PSI is required for the BAF loads. The main distribution will be via nominal 4" dia. stainless steel piping, with branch circuits of 2" pipe. Connection to local loads will be through flexible non-metallic, radiation resistant hoses.

#### 2.16 Installation

It is planned to install the water distribution system, cables and cable trays, and survey monuments immediately following completion of conventional construction.

The survey monuments will be used to locate the accelerator and beam line components.

The magnets will be installed with their stands and surveyed in place. Vacuum chamber components not assembled as part of the magnets will be installed to complete the vacuum enclosure.

Power supplies will be installed in the support buildings as they are received from vendors. It is expected that each supply will be pre-tested before installed.

Electrical distribution switchgear, cabling, and terminations not included as part of conventional construction will be included as part of the project installation. Typically, this would include individual feeds to power supplies and electronic devices.

Hook-up of the magnets to the water system will be accomplished after surveying is complete, followed by connection of the magnets, beam instrumentation, and other electronic devices to the appropriate electrical cables. The cable system includes high power, high current, coaxial, control, and fiber optic cables.

The installation schedule will be planned by the project physics and engineering staff.

Components will be placed by Laboratory riggers and surveyed in place by project personnel. The overall installation task will require mechanical and electrical technicians, welders, masons, electricians, carpenters, machinists, and laborers.

The final installation items will be the security system, and radiation shielding and detection devices.

# **Project Performance**

**3**

## 3.0 PROJECT PERFORMANCE

### 3.1. GENERAL

- 3.1.1 Overall Project Management, Quality Assurance, and Engineering and Design of technical components will be performed by BNL.
- 3.1.2 Conventional Facilities design for Title I and Title II, and Construction Observation of Title III will be performed by BNL.
- 3.1.3 Title III Conventional Construction will be performed by a lump-sum, competitively bid, construction contract. Title III Technical Construction will be performed by BNL crafts except where technology can be transferred cost effectively to outside contractors for a competitively bid, lump-sum contract.
- 3.1.4 The project will be managed in accordance with BNL's Implementation Plan for DOE O 430.1, "Life Cycle Asset Management".

A Project Execution Plan will be developed during the initiation of the project and will be available for review and approval. The plan will indicate the scope, cost, and schedule; change control methods; methods of execution, responsible parties and lines of authority; quality assurance methods of execution, responsible parties and lines of authority; quality assurance methods; and review and reporting requirements.

### 3.2 PROJECT SCHEDULE

The design and construction schedule for this project is detailed on the bar chart, Figure 3.2.

# Booster Applications Facility

## Master Milestone Schedule

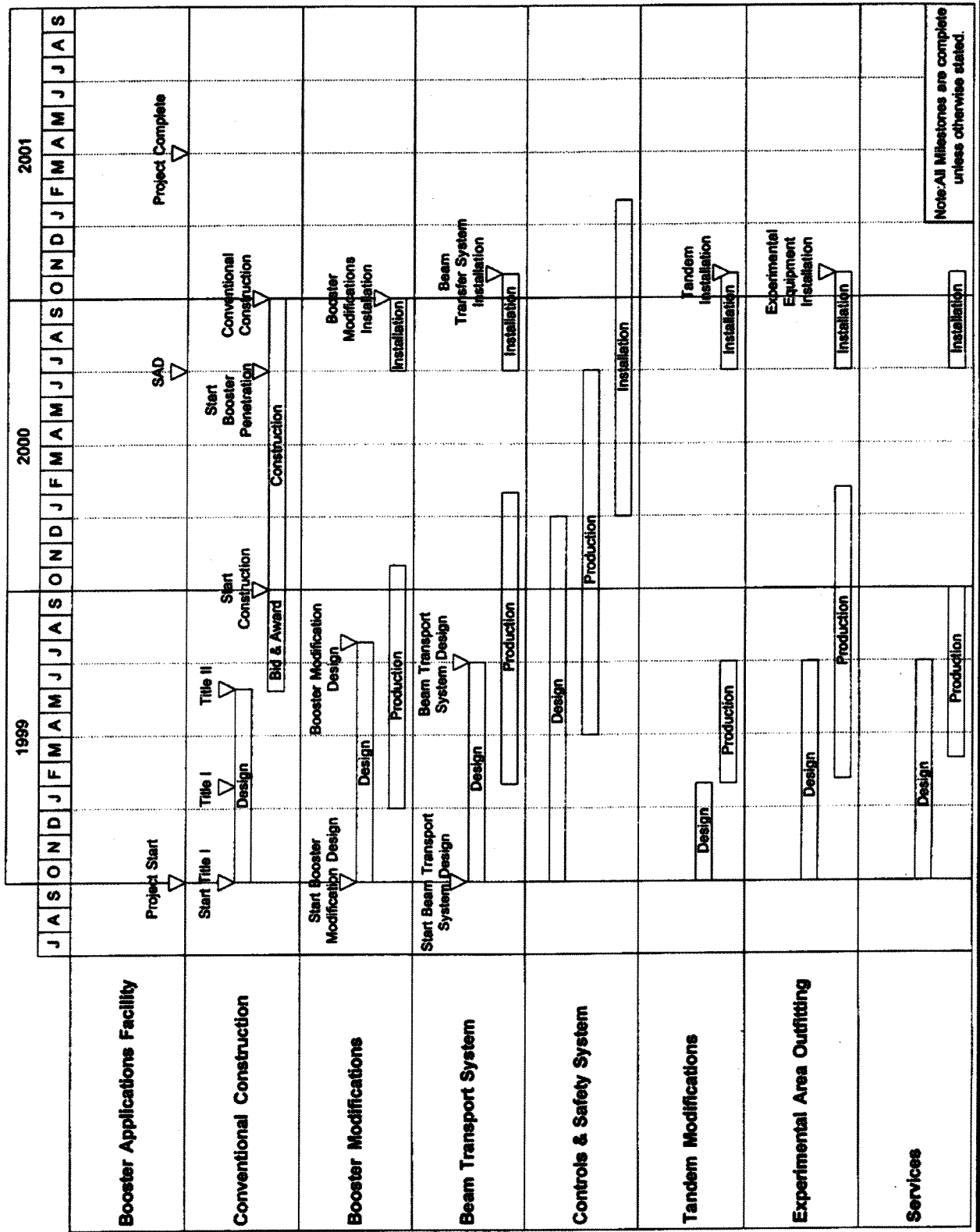

Figure 3.2 Project Schedule

# **Requirements & Assessments**

**4**



## 4.0 REQUIREMENTS AND ASSESSMENTS

### 4.1 Environmental Protection

The potential sources of environmental impact were evaluated with respect to the following activities.

#### 4.1.1 Excavation and Backfill

Given the design of the excavation activity, the resulting noise and dust will be minimal. Such activities have very negligible impact and are considered routine and commonplace.

#### 4.1.2 Environmental Releases

Use of solid or liquid hazardous and/or radioactive material shall be in compliance with Federal, State and County requirements. The following rules and policies shall be addressed in the subsequent Environment, Safety and Health analysis for the facility.

- Executive Orders 11593, 11752, 11912, 11988, 11990, and 12003
- Clean Air Act
- Department of Energy Policy and Instructional Memoranda
- Endangered Species Act
- Federal Water Pollution Control Act
- National Historic Preservation Act
- National Emission Standards for Hazardous Air Pollutants
- National Environmental Policy Act
- Resource Conservation and Recovery Act
- Toxic Substances Control Act
- 40 CFR Part 265
- New York State Freshwater Wetlands Act

- New York State Pollutant Discharge Elimination System
- 6 NYCRR Part 373-3
- Suffolk County Articles 6, 7, 10 and 12
- BNL Environmental, Safety and Health Standards
- BNL Standard Operating Procedures

## 4.2 Security Requirements

This project was reviewed by the Safeguards and Security Division of BNL. No inherent security impact was identified.

## 4.3 Safety Evaluation

### 4.3.1 Radiation

Potential radiation doses to radiation workers and the on site and off site public shall be analyzed and reported in the Safety Assessment Document (SAD) for the facility. The radiological analysis will be based on the BAF Design Criteria and Radiation Protection Policy stated in the BAF SAD .

### 4.3.2 Life Safety

Exits from the proposed addition will be provided in accordance with the NFPA 101 Life Safety Code to assure adequate egress from the buildings and tunnels in the event of an emergency. The preliminary design calls for a wet pipe sprinkler system and fire detection system.

## 4.4 Quality Assurance Program

The BAF Project will adopt, in its entirety, the AGS Department's Quality Assurance Program. The AGS Quality Assurance Program (QAP) addresses the Basic Requirement of DOE Order 5700.6C, dated 08/21/91, pages 5-7. The QAP presents a

written description of the Quality Assurance (QA) activities that will be implemented in the BAF Project. The program describes how the prevention, assessment and correction functions of QA will be planned and integrated into all BAF Project activities in a timely and cost effective manner.

QA procedures that describe methods for consistently and efficiently implementing each of the basic requirements of DOE 5700.6C have been developed. These QA procedures are included in the AGS Department Quality Assurance Manual.

#### 4.5 Environmental Evaluation

In accordance with DOE Order 5440.1E an environmental evaluation of impacts associated with this action have been analyzed to satisfy the requirements of the National Environmental Policy Act (NEPA). Following DOE's published rules for the implementation of NEPA, 10 CFR 1021, it was determined that an Environmental Assessment (EA) would be the appropriate level of documentation necessary to evaluate the proposed action and alternatives. An EA has been prepared for the project and submitted to DOE for approval.

# Project Cost Estimate

5

## 5.0 PROJECT COST ESTIMATE

### 5.1 Basis of Estimate

Cost estimates were prepared in FY '98 based on analysis of associated costs with tasks identified on the Work Breakdown Structure (WBS) and are as follows:

#### 5.1.1 WBS 1.1 Conventional Construction

Material quantities were derived from drawings and field measurements.

Installation labor wages are union crew rates, comprised of direct wages, fringe benefits, taxes and insurance and were derived from R.S. Means Estimating Guide.

Indirect costs for lump sum construction contracts were derived from R.S. Means Estimating Guide and a review of existing contracts and include contractors expenses for superintendent, field office, profit, insurance, taxes, bonds, office expenses, temporary construction, small tools, and overtime for shutdowns, tie-ins, and other items requiring work beyond normal working hours.

Prime Contractor's Mark-up

Calculated at 7% of direct costs assuming all contracts are managed by a general contractor.

#### 5.1.2 WBS 1.2 - 1.7 Technical Construction

Technical equipment and materials were derived by analysis of the requirements of the machine components. Most costs are derived by the engineer based on their past experience with similar research equipment. No estimating guides exists for their kind of work. When equipment is available commercially, vendor quotes are solicited. Occasionally, the vendor will also install his equipment.

No additional mark-ups are added to these estimates. Vendor quotes are fully burdened as are the historical engineering estimates. However, the historical values were projected into today's dollars.

#### 5.1.3 WBS 1.8 Project Services

Costs for BNL project services were based on projected manpower and other resources for Project Management, fiscal, QA and ES&H functions.

Contingency is estimated based on engineering assessment of risks associated with cost estimates due to unforeseen job conditions, uncertainties of market conditions for labor and materials and level of design. For the project, contingency was calculated for each WBS element and ranged from 10% for Project Services to 30% for Personnel Safety System. Convention Construction was calculated at 15%. Contingency for the entire project is approximately 18.3%. A complete analysis is shown in the cost estimate summary back-up.

The At-Year dollars are calculated by applying the escalation rates to the project forecasted annual expenditures. Rates are taken from DOE Departmental Price Change Index-FY 1999 Guidance, January 1997 Update.

1999	2.8%
2000	2.9%
2001	2.9%

## 5.2 Project Cost Summary

The following are WBS Level II Summary Cost Estimates in FY '98 dollars, a Resource Analysis and Obligation/Spending Profile.

**BOOSTER APPLICATIONS FACILITY (BAF)  
COST ESTIMATE  
RESOURCE ANALYSIS  
(\$ IN THOUSANDS)**

	Materials	EDI	Assy/Test & Install. *	TOTAL
<b>1 BAF CONSTRUCTION ( AY \$ )</b>	<b>13,031</b>	<b>5,081</b>	<b>5,363</b>	<b>23,475</b>
<b>1.1 CONVENTIONAL CONSTRUCTION</b>	<b>2,461</b>	<b>331</b>	<b>0</b>	<b>2,792</b>
<b>1.2 BOOSTER MODIFICATIONS</b>	<b>1,625</b>	<b>790</b>	<b>990</b>	<b>3,405</b>
<b>1.3 BEAM TRANSPORT SYSTEM</b>	<b>2,323</b>	<b>691</b>	<b>1,167</b>	<b>4,181</b>
<b>1.4 CONTROLS &amp; PERSONNEL SAFETY SYSTEM</b>	<b>451</b>	<b>652</b>	<b>145</b>	<b>1,248</b>
<b>1.5 TANDEM MODIFICATIONS</b>	<b>385</b>	<b>62</b>	<b>145</b>	<b>592</b>
<b>1.6 EXP. AREA OUTFITTING</b>	<b>862</b>	<b>820</b>	<b>158</b>	<b>1,840</b>
<b>1.7 INSTALLATION &amp; SERVICES</b>	<b>906</b>	<b>186</b>	<b>279</b>	<b>1,371</b>
<b>1.8 PROJECT SERVICES</b>	<b>92</b>	<b>0</b>	<b>851</b>	<b>943</b>
<b>CONTINGENCY</b>	<b>1,726</b>	<b>690</b>	<b>722</b>	<b>3,138</b>
<b>OVERHEAD</b>	<b>1,625</b>	<b>633</b>	<b>669</b>	<b>2,927</b>
<b>ESCALATION</b>	<b>576</b>	<b>225</b>	<b>237</b>	<b>1,038</b>

\* Includes Project Services WBS 1.8

**BOOSTER APPLICATIONS FACILITY (BAF)  
 COST ESTIMATE  
 SPENING PROFILE  
 (\$ IN THOUSANDS)**

	TOTAL	FY1999	FY 2000	FY 2001
<b>1 BAF CONSTRUCTION ( AY \$ )</b>	23,475	11,021	11,179	1,275
<b>1.1 CONVENTIONAL CONSTRUCTION</b>	2,792	431	2,261	100
<b>1.2 BOOSTER MODIFICATIONS</b>	3,405	2,246	1,159	0
<b>1.3 BEAM TRANSPORT SYSTEM</b>	4,181	2,782	1,399	0
<b>1.4 CONTROLS &amp; PERSONNEL SAFET</b>	1,248	521	602	125
<b>1.5 TANDEM MODIFICATIONS</b>	592	505	88	0
<b>1.6 EXP. AREA OUTFITTING</b>	1,040	579	1,145	116
<b>1.7 INSTALLATION &amp; SERVICES</b>	1,371	312	616	444
<b>1.8 PROJECT SERVICES</b>	943	448	426	69
<b>CONTINGENCY</b>	3,138	1,500	1,475	164
<b>OVERHEAD</b>	2,927	1,398	1,376	153
<b>ESCALATION</b>	1,038	300	633	105



### 5.3 Project Cost Breakdown by WBS

The following are WBS Level IV Cost Estimates in FY '98 dollars, a Resource Analysis and Obligation/Spending Profile.

**BOOSTER APPLICATIONS FACILITY (BAF)  
COST ESTIMATE  
RESOURCE ANALYSIS  
(\$ IN THOUSANDS)**

	Materials	EDI	Assy/Test & Install. *	TOTAL	Contingency
<b>1 BAF CONSTRUCTION (AY \$)</b>	<b>13,031</b>	<b>5,081</b>	<b>5,363</b>	<b>23,475</b>	<b>19.2%</b>
<b>1.1 CONVENTIONAL CONSTRUCTION</b>	<b>2,461</b>	<b>331</b>	<b>0</b>	<b>2,792</b>	<b>15.0%</b>
1.1.1 Improvements to Land	508	71		579	15%
1.1.2 Bldgs., Tunnels, & Structures	1,441	202		1,643	15%
1.1.3 Utilities	412	58		470	15%
1.1.4 Standard Equipment	100	0		100	15%
<b>1.2 BOOSTER MODIFICATIONS</b>	<b>1,625</b>	<b>790</b>	<b>990</b>	<b>3,405</b>	<b>23.5%</b>
<b>1.2.1 NEW EXTRACTION EQUIPMENT</b>	<b>424</b>	<b>184</b>	<b>205</b>	<b>812</b>	<b>24.1%</b>
1.2.1.1 Thin Septum Magnet	158	81	72	310	25%
1.2.1.2 Thick Septum Magnet	207	65	85	358	25%
1.2.1.3 Foil Stripper Assembly	59	38	48	144	20%
<b>1.2.2 POWER SUPPLIES</b>	<b>897</b>	<b>354</b>	<b>470</b>	<b>1,721</b>	<b>24.2%</b>
1.2.2.1 Thin Septum Magnet	68	80	89	237	25%
1.2.2.2 EJ Septum	271	138	158	567	25%
1.2.2.3 Tune Quads	316	20	42	378	20%
1.2.2.4 Sextupoles	66	29	78	173	25%
1.2.2.5 Bump	140	43	83	266	25%
1.2.2.6 Spill Servo	36	44	20	100	30%
<b>1.2.3 EQUIPMENT MODIFICATIONS</b>	<b>305</b>	<b>253</b>	<b>315</b>	<b>872</b>	<b>21.4%</b>
1.2.3.1 D4 & D6	137	34	78	249	25%
1.2.3.2 D6 Beam Dump & Wall Current Monitor	76	44	38	158	20%
1.2.3.3 D3 IPM & Beam Dump Kicker	5	15	21	41	20%
1.2.3.4 Vacuum System Modifications	88	160	178	426	20%
<b>1.3 BEAM TRANSPORT SYSTEM</b>	<b>2,323</b>	<b>691</b>	<b>1,167</b>	<b>4,181</b>	<b>20.4%</b>
<b>1.3.1 MAGNETS</b>	<b>673</b>	<b>158</b>	<b>253</b>	<b>1,084</b>	<b>20.0%</b>
1.3.1.1 Dipoles	238	37	65	340	20%
1.3.1.2 Quadrupoles	240	44	127	412	20%
1.3.1.3 Octupoles	90	45	30	165	20%
1.3.1.4 Low Field Magnets	105	32	30	167	20%
<b>1.3.2 POWER SUPPLIES</b>	<b>426</b>	<b>57</b>	<b>119</b>	<b>602</b>	<b>22.7%</b>
1.3.2.1 Dipole	72	13	22	107	20%
1.3.2.2 Quadrupole	264	13	42	319	25%
1.3.2.3 High Order Multipole	30	18	22	70	20%
1.3.2.4 Corrector	60	13	33	106	20%
<b>1.3.3 VACUUM SYSTEM</b>	<b>562</b>	<b>204</b>	<b>356</b>	<b>1,122</b>	<b>20.0%</b>
1.3.3.1 Beam Tubes, Bellows & Valves	265	52	140	457	20%
1.3.3.2 Pumps, Power Supplies, Gauges, etc.	222	32	91	346	20%
1.3.3.3 Instrumentation & Controls	43	86	66	195	20%
1.3.3.4 Transport Line Bakeout System	32	34	58	124	20%

	Materials	EDI	Assy/Test/In	TOTAL	Contingency
<b>1.3.4 INSTRUMENTATION</b>	<b>662</b>	<b>272</b>	<b>439</b>	<b>1,373</b>	<b>20.0%</b>
1.3.4.1 Flags & Cameras	164	39	176	379	20%
1.3.4.2 Collimators	117	40	37	194	20%
1.3.4.3 Ion Chamber	153	96	105	354	20%
1.3.4.4 SWIC's	228	97	122	448	20%
<b>1.4 CONTROLS &amp; PERSONNEL SAFETY SYSTEM</b>	<b>451</b>	<b>652</b>	<b>145</b>	<b>1,248</b>	<b>16.4%</b>
1.4.1 CONTROLS	375	641	133	1,149	15.2%
1.4.1.1 Distributed System	143	78	36	257	16%
1.4.1.2 Central Services	46	407	42	495	15%
1.4.1.3 Process Controls	185	156	55	396	15%
1.4.2 PERSONNEL SAFETY SYSTEM	76	11	12	99	30%
<b>1.5 TANDEM MODIFICATIONS</b>	<b>385</b>	<b>62</b>	<b>145</b>	<b>592</b>	<b>20.0%</b>
1.5.1 Power Supplies	220	6	28	254	20%
1.5.2 Instrumentation	84	52	112	248	20%
1.5.3 Radiation Safety & Power Distribution	81	4	6	91	20%
<b>1.6 EXP. AREA OUTFITTING</b>	<b>862</b>	<b>820</b>	<b>158</b>	<b>1,840</b>	<b>17.6%</b>
1.6.1 DOSIMETRY CONTROL	339	820	104	1,263	20.0%
1.6.1.1 Computer System	39	95	12	146	20%
1.6.1.2 Control Room	67	162	22	251	20%
1.6.1.3 Beam Line Devices	114	273	30	417	20%
1.6.1.4 Beam Line Electronics	47	114	16	177	20%
1.6.1.5 Beam Line & Misc. Support Systems	65	157	22	244	20%
1.6.1.6 Calibration & Test Equipment	8	19	3	30	20%
1.6.2 SUPPORT ROOMS - General	25	0	5	30	15%
1.6.3 SUPPORT ROOM "A"	32	0	20	52	15%
1.6.4 SUPPORT ROOM "C"	149	0	30	179	15%
1.6.5 LONG TERM SUPPORT LAB	316	0	0	316	10%
<b>1.7 INSTALLATION &amp; SERVICES</b>	<b>906</b>	<b>186</b>	<b>279</b>	<b>1,371</b>	<b>22.1%</b>
1.7.1 ELECTRIC POWER DISTRIBUTION	106	43	10	159	25%
1.7.2 EQUIPMENT COOLING WATER	276	72	56	404	15%
1.7.3 INSTALLATION	524	71	213	808	25.0%
1.7.3.1 Cable Tray & Conduit	123	21	70	214	25%
1.7.3.2 AC Cables & Hookups	105	14	11	131	25%
1.7.3.3 DC Cables & Hookups	292	14	17	323	25%
1.7.3.4 Rigging	1		36	37	25%
1.7.3.5 Survey	2	18	39	59	25%
1.7.3.6 Coordination		4	40	44	25%
<b>1.8 PROJECT SERVICES</b>	<b>92</b>	<b>0</b>	<b>851</b>	<b>943</b>	<b>12.7%</b>
1.8.1 PROJECT MANAGEMENT	50		385	435	10%
1.8.2 FISCAL	10		198	208	10%
1.8.3 QUALITY ASSURANCE	10		39	49	10%
1.8.4 ES&H	22		229	251	20%
<b>CONTINGENCY</b>	<b>1,726</b>	<b>690</b>	<b>722</b>	<b>3,138</b>	
<b>OVERHEAD</b>	<b>1,625</b>	<b>633</b>	<b>669</b>	<b>2,927</b>	
<b>ESCALATION</b>	<b>576</b>	<b>225</b>	<b>237</b>	<b>1,038</b>	

\* Includes Project Services WBS 1.8

**BOOSTER APPLICATIONS FACILITY (BAF)  
COST ESTIMATE  
SPENDING PROFILE  
(\$ IN THOUSANDS)**

	TOTAL	FY1999	FY 2000	FY 2001
<b>1 BAF CONSTRUCTION ( AY \$ )</b>	<b>23,475</b>	<b>11,021</b>	<b>11,179</b>	<b>1,275</b>
<b>1.1 CONVENTIONAL CONSTRUCTION</b>	<b>2,792</b>	<b>431</b>	<b>2,261</b>	<b>100</b>
1.1.1 Improvements to Land	578	71	508	0
1.1.2 Bldgs., Tunnels, & Structures	1,643	302	1,341	0
1.1.3 Utilities	470	58	412	0
1.1.4 Standard Equipment	100	0	0	100
<b>1.2 BOOSTER MODIFICATIONS</b>	<b>3,405</b>	<b>2,246</b>	<b>1,159</b>	<b>0</b>
<b>1.2.1 NEW EXTRACTION EQUIPMEN</b>	<b>512</b>	<b>588</b>	<b>223</b>	<b>0</b>
1.2.1.1 Thin Septum Magnet	310	232	78	
1.2.1.2 Thick Septum Magnet	358	260	98	
1.2.1.3 Foil Stripper Assembly	144	96	48	
<b>1.2.2 POWER SUPPLIES</b>	<b>1,721</b>	<b>1,108</b>	<b>613</b>	<b>0</b>
1.2.2.1 Thin Septum Magnet	237	138	100	
1.2.2.2 EJ Septum	567	379	188	
1.2.2.3 Tune Quads	378	263	115	
1.2.2.4 Sextupoles	173	96	77	
1.2.2.5 Bump	266	169	97	
1.2.2.6 Spill Servo	109	63	37	
<b>1.2.3 EQUIPMENT MODIFICATIONS</b>	<b>472</b>	<b>550</b>	<b>323</b>	<b>0</b>
1.2.3.1 D4 & D6	249	157	92	
1.2.3.2 D6 Beam Dump & Wall Current	158	120	38	
1.2.3.3 D3 IPM & Beam Dump Kicker	91	20	21	
1.2.3.4 Vacuum System Modifications	425	253	172	
<b>1.3 BEAM TRANSPORT SYSTEM</b>	<b>4,181</b>	<b>2,782</b>	<b>1,399</b>	<b>0</b>
<b>1.3.1 MAGNETS</b>	<b>1,004</b>	<b>828</b>	<b>256</b>	<b>0</b>
1.3.1.1 Dipoles	340	275	65	
1.3.1.2 Quadrupoles	412	281	130	
1.3.1.3 Octupoles	169	135	30	
1.3.1.4 Low Field Magnets	167	137	30	
<b>1.3.2 POWER SUPPLIES</b>	<b>602</b>	<b>284</b>	<b>319</b>	<b>0</b>
1.3.2.1 Dipole	107	65	43	
1.3.2.2 Quadrupole	319	164	156	
1.3.2.3 High Order Multipole	70	25	44	
1.3.2.4 Corrector	106	31	76	
<b>1.3.3 VACUUM SYSTEM</b>	<b>1,122</b>	<b>733</b>	<b>389</b>	<b>0</b>
1.3.3.1 Beam Tubes, Bellows & Valves	457	291	166	
1.3.3.2 Pumps, Power Supplies, Gauge	345	254	91	
1.3.3.3 Instrumentation & Controls	195	124	72	
1.3.3.4 Transport Line Bakeout System	124	64	60	

	TOTAL	FY1999	FY 2000	FY 2001
<b>1.3.4 INSTRUMENTATION</b>	<b>1,373</b>	<b>937</b>	<b>436</b>	<b>0</b>
1.3.4.1 Flags & Cameras	379	233	146	
1.3.4.2 Collimators	194	157	37	
1.3.4.3 Ion Chamber	354	263	91	
1.3.4.4 SWIC's	446	285	161	
<b>1.4 CONTROLS &amp; PERSONNEL SAFETY</b>	<b>1,248</b>	<b>521</b>	<b>602</b>	<b>125</b>
1.4.1 CONTROLS	1,149	510	555	84
1.4.1.1 Distributed System	257	144	112	2
1.4.1.2 Central Services	496	125	303	67
1.4.1.3 Process Controls	396	241	140	15
1.4.2 PERSONNEL SAFETY SYSTEM	99	11	47	41
<b>1.5 TANDEM MODIFICATIONS</b>	<b>592</b>	<b>505</b>	<b>88</b>	<b>0</b>
1.5.1 Power Supplies	254	254		
1.5.2 Instrumentation	248	160	88	
1.5.3 Radiation Safety & Power Distri	91	91		
<b>1.6 EXP. AREA OUTFITTING</b>	<b>1,840</b>	<b>579</b>	<b>1,145</b>	<b>116</b>
1.6.1 DOSIMETRY CONTROL	1,263	579	579	105
1.6.1.1 Computer System	145	67	66	12
1.6.1.2 Control Room	251	114	115	22
1.6.1.3 Beam Line Devices	417	194	193	30
1.6.1.4 Beam Line Electronics	177	80	81	16
1.6.1.5 Beam Line & Misc. Support Sys	244	111	111	22
1.6.1.6 Calibration & Test Equipment	30	13	14	3
1.6.2 SUPPORT ROOMS - General	30		29	1
1.6.3 SUPPORT ROOM "A"	52		48	4
1.6.4 SUPPORT ROOM "C"	179		173	6
1.6.5 LONG TERM SUPPORT LAB	316		316	
<b>1.7 INSTALLATION &amp; SERVICES</b>	<b>1,371</b>	<b>312</b>	<b>616</b>	<b>444</b>
1.7.1 ELECTRIC POWER DISTRIBUTI	159	43	88	29
1.7.2 EQUIPMENT COOLING WATER	404	193	170	41
1.7.3 INSTALLATION	808	75	358	374
1.7.3.1 Cable Tray & Conduit	214	21	97	97
1.7.3.2 AC Cables & Hookups	131	14	58	58
1.7.3.3 DC Cables & Hookups	323	14	159	150
1.7.3.4 Rigging	37		9	28
1.7.3.5 Survey	59	18	15	26
1.7.3.6 Coordination	44	8	20	16
<b>1.8 PROJECT SERVICES</b>	<b>943</b>	<b>448</b>	<b>426</b>	<b>69</b>
1.8.1 PROJECT MANAGEMENT	435	196	196	43
1.8.2 FISCAL	208	93	93	22
1.8.3 QUALITY ASSURANCE	49	23	23	4
1.8.4 ES&H	251	136	114	
	<b>16,372</b>	<b>7,823</b>	<b>7,696</b>	<b>854</b>
<b>CONTINGENCY</b>	<b>3,138</b>	<b>1,500</b>	<b>1,475</b>	<b>164</b>
<b>OVERHEAD</b>	<b>2,927</b>	<b>1,398</b>	<b>1,376</b>	<b>153</b>
<b>ESCALATION</b>	<b>1,038</b>	<b>300</b>	<b>633</b>	<b>105</b>