

TM 9-421

WAR DEPARTMENT

TECHNICAL MANUAL

3-INCH SEACOAST GUN MATERIEL

3-INCH (15-PDR.) GUN M1902MI MOUNTED ON

3-INCH (15-PDR.) BARBETTE CARRIAGE M1902

AND

3-INCH (15-PDR.) GUN M1903 MOUNTED ON

3-INCH (15-PDR.) BARBETTE CARRIAGE M1903

OCTOBER 10, 1942

JUL 12 1942

*TM 9-421

TECHNICAL MANUAL
No. 9-421

PROPERTY OF U. S. ARMY

WAR DEPARTMENT,
Washington, October 10, 1942.

3-INCH SEACOAST GUN MATERIEL

3-INCH (15-PDR.) GUN M1902MI MOUNTED ON
3-INCH (15-PDR.) BARBETTE CARRIAGE M1902
AND
3-INCH (15-PDR.) GUN M1903 MOUNTED ON
3-INCH (15-PDR.) BARBETTE CARRIAGE M1903

Prepared under the direction of the
Chief of Ordnance

CONTENTS

	Paragraphs	Pages
CHAPTER 1: Introduction	1- 3	4- 8
CHAPTER 2: Gun and carriage	4-38	9- 72
SECTION I: Description of guns	4- 6	9- 16
II: Description of carriages	7-12	17- 32
III: Operation	13-16	33- 39
IV: Malfunction and correction	17-18	40- 41
V: Care and preservation	19-27	42- 64
VI: Inspection and adjustment	28-37	65- 71
VII: Repair	38	72
CHAPTER 3: Ammunition	39-52	73- 96
CHAPTER 4: Spare parts and accessories	53-61	97-102
CHAPTER 5: Subcaliber equipment	62-66	103-108
CHAPTER 6: Painting	67-71	109-111
CHAPTER 7: Materiel affected by gas	72-74	112-114
CHAPTER 8: Operation under unusual conditions	75	115-117
CHAPTER 9: References	76-78	118-119
INDEX		120-125

* This TM supersedes ORD 1772, Description of 3-inch (15-pdr.) Gun M1903 and its Breech Mechanism, revised June 5, 1917; and in part ORD 1766, Instructions for Mounting, Using, and Caring for 3-inch (15-pdr.) Gun and Barbette Carriage M1902, revised October 30, 1913; and in part ORD 1701, Instructions for Mounting, Using, and Caring for 3-inch (15-pdr.) Barbette Carriage M1903, revised May 8, 1916.

9 030654

3-INCH SEACOAST GUN MATERIEL

PROPERTY OF U.S. ARMY

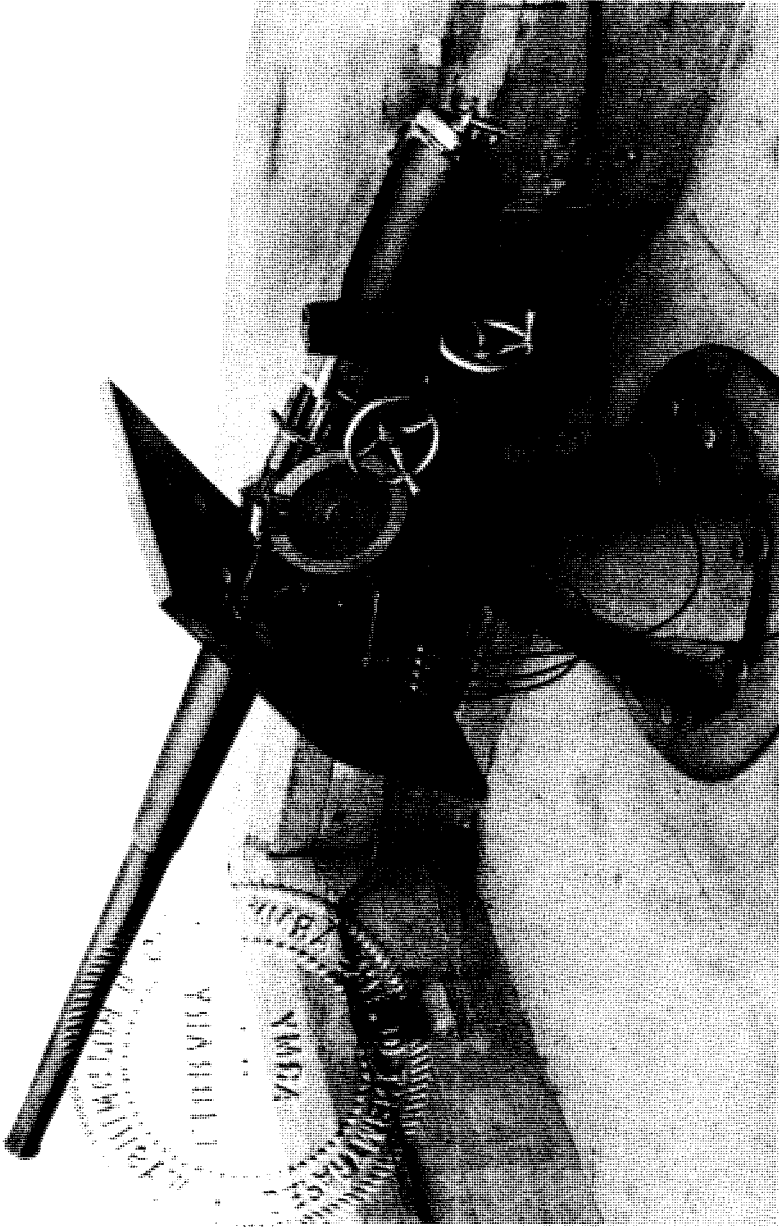

RA PD 35782

Figure 1—3-inch (15-PDR.) Gun M1902MI Mounted on 3-inch Barbette Carriage M1902

3-INCH SEACOAST GUN MATERIEL

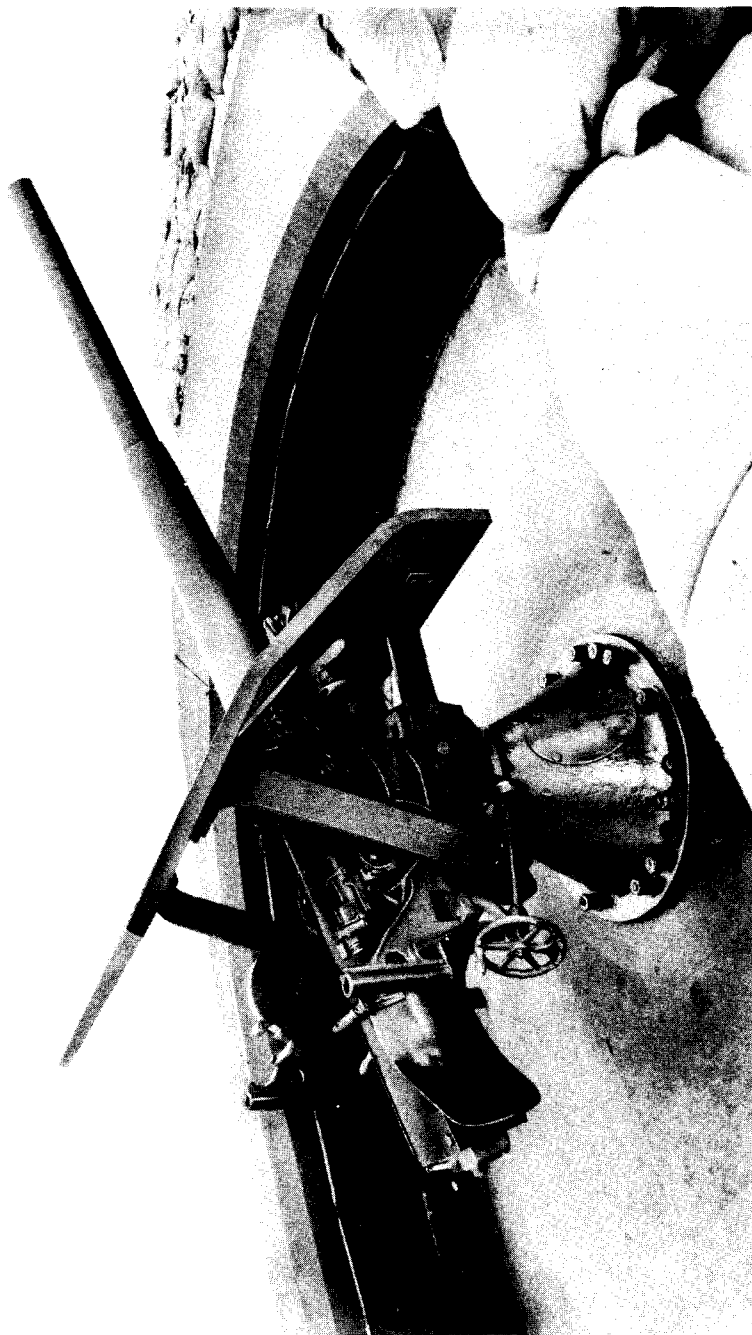

RA PD 35783

Figure 2—3-inch (15-PDR.) Gun M1903 Mounted on 3-inch Barquette Carriage M1903

3-INCH SEACOAST GUN MATERIEL

Chapter 1

INTRODUCTION

	Paragraph
Scope	1
Characteristics	2
Data	3

1. SCOPE.

a. This manual is published for the information and guidance of the using arms and service.

b. In addition to a description of the 3-inch guns M1902 and M1903, this manual contains technical information required for the identification, use, and care of the materiel.

c. Disassembly, assembly; and such repairs as may be handled by using arm personnel may be undertaken only under the supervision of an officer or the chief mechanic.

d. In all cases where the nature of the repair, modification, or adjustment is beyond the scope or facilities of the unit, the responsible ordnance service should be informed so that trained personnel with suitable tools and equipment may be provided, or proper instructions issued.

e. Instructions for the care and use of the sighting and fire control instruments are not included in this manual but are covered in FM 4-15.

2. CHARACTERISTICS.

a. All 3-inch (15-pdr.) guns M1902MI are mounted on barbette carriage M1902, and all 3-inch (15-pdr.) guns M1903 are mounted on barbette carriage M1903.

b. The 3-inch (15-pdr.) guns are rapid-fire weapons, able to fire in all directions (360-deg. traverse). The maximum elevation attainable is approximately 15 degrees.

c. An improved lighting circuit, using a storage battery, is to be furnished the M1903 carriages. Some M1903 carriages are not equipped with this improved lighting circuit as yet, but are using the emplacement mains as the source of power for lighting. The M1902 carriages are equipped with storage batteries.

d. The visible differences between the models of these guns and carriages are as follows:

INTRODUCTION

M1902

M1903

- (1) Open handhole.
- (2) Sighting apparatus on left side.
- (3) Traversing and elevating handwheels on left side of carriage.
- (4) No firing lever.
- (5) Power for lighting furnished by battery on left side of carriage.
- (6) One shoulder rest on left side of carriage.
- (7) One shoulder guard on left side of carriage.

- (1) Covered handhole.
- (2) Sighting apparatus on right side.
- (3) Elevating handwheel on left side of carriage, traversing handwheel on right side.
- (4) Equipped with firing lever.
- (5) Power for lighting furnished from emplacement main for some guns; others have battery on right side of carriage.
- (6) Two shoulder rests, one on each side of carriage.
- (7) Two shoulder guards, one on each side of carriage.

e. The inherent differences between the models of these guns and carriages are as follows:

M1902

M1903

- (1) Pivot yoke thrust bearing suspended and supported midway up the pedestal.
- (2) Not equipped with 360 degrees electrical contact for lighting circuit.
- (3) Recoil and counterrecoil controlled by grooves in the cradle liner.

- (1) Pivot yoke thrust bearing rests on base of pedestal.
- (2) Equipped with 360 degrees electrical contact for lighting circuit.
- (3) Recoil and counterrecoil controlled by slide in the cradle.

3. DATA.

a. Guns, 3-inch (15-pdr.), M1902MI and M1903.

	M1902MI	M1903
Length, total over-all inches	159	175
Length, muzzle to breech face inches	154.35	170
Length of bore calibers	50	50
Maximum diameter of chamber inches	3.904	4.31
Weight, including breech mechanism . . . pounds	1,950	2,690
Type of construction	Built-up	Built-up

3-INCH SEACOAST GUN MATERIEL

	M1902MI	M1903
Rifling:		
Twist	R.H. in- creasing from 1-50 at origin to 1-25	R.H. in- creasing from 1-50 at origin to 1-25
Number of grooves	24	24
Width of groove	inches 0.2927	0.2927
Depth of groove	inches 0.03	0.03
Width of land	inches 0.10	0.10
Type of breechblock	Slotted screw	Slotted screw
Type of breech mechanism	Lever pull	Lever pull
Number of handles to operate	1	1
Power	Hand	Hand
Type of firing mechanism	Continuous pull type	Continuous pull type
Muzzle velocity, maximum	feet per second 2,800	2,800
Range, maximum:		
(Using Shell, H. E., M42 and M42A1) yards	10,645	10,943
(Using Shell, H. E., 15 lb, M1915)	10,988	11,328
(Using Shell, H. E., MK1)	—	9,177
Life of gun (full charge)	rounds 2,500	2,500
Rate of fire (normal)	rounds per minute 12	12
Rate of fire (maximum)	rounds per minute 30	30

**b. Carriages, Barbette, 3-inch (15-pdr.),
M1902 and M1903**

Type	Pedestal	Pedestal
Total weight	pounds 4,075	3,310
Elevating mechanism:		
Type	Worm	Screw
Power	Hand	Hand
Speed	degrees per turn 1.03	Variable
Maximum elevation	degrees + 15	+ 16
Minimum elevation	degrees - 10*	- 10*
Traversing mechanism:		
Type of bearing	Ball	Ball
Mean diameter of roller path	inches 4.375	3.3
Maximum traverse	degrees 360	360
Pedestal, outer flange diameter	inches 41	42

* Dependent upon construction and emplacement.

INTRODUCTION

	M1902	M1903
Recoil mechanism:		
Type	Hydraulic	Hydraulic
Number of cylinders	1	1
Length of recoil	9	9
Orifices	Grooved	Grooved
Buffer	Valve	Valve
Recuperating mechanism:		
Type	Spring	Spring
Electric lighting circuit:		
Power (storage battery—5-cell B4) .. volts	6	6
Lamps:		
Deflection scale (lamp, elect., incand., min., 6-8 v., sgle., tung., fil.)	No. 51	No. 64
Telescope (lamp, elect., incand., min., 6-8 v., sgle., tung., fil.)	No. 51	No. 64
Range scale (lamp, elect., incand., min., 6-8 v., sgle., tung., fil.)	No. 64	No. 64
Night sight (lamp, elect., incand., min., 6-8 v., sgle., tung., fil.)	No. 51	—
Switch (toggle, surface type) .. amperes	5	5

c. Subcaliber Equipment.

Weight of 3-inch subcaliber cartridge			
assembled	pounds	27.8	31.0
Length of .30 caliber rifle barrel			
including chamber	inches	33.5	36.8
Muzzle velocity	feet per second	2,025	2,095
Maximum breech pressure—			
	pounds per square inch	40,000	40,000
Range, maximum	yards	4,300	4,300
.30 caliber subcaliber cartridge M1925:			
Weight, assembled	grains	385.5	385.5
Weight of case	grains	173.4	173.4
Weight of bullet, M1925	grains	172.0	172.0
Weight of powder charge	grains	35.0	35.0
Weight of primer	grains	5.37	5.37

3-INCH SEACOAST GUN MATERIEL

d. Sighting and Fire Control Instruments.

(1) The sighting equipment supplied with this gun may include the following instruments:

- (a) Telescope
- (b) Mount, telescope
- (c) Quadrant, gunner's
- (d) Sight, bore

(2) Fire control equipment supplied with this gun may include the following instrument which, at various harbor defenses, may vary as to model:

Finder, coincidence, range.

Chapter 2

GUN AND CARRIAGE

Section I

DESCRIPTION OF GUNS

	Paragraph
3-inch guns M1902MI and M1903	4
Breech mechanism	5
Firing mechanism	6

4. 3-INCH GUNS M1902MI AND M1903.

These guns are of the built-up type. The jacket fits over the rear end of the tube and projects beyond it. The breech bushing is screwed into the end of the jacket and the breech mechanism is assembled into the bushing. The breech bushing bears interrupted threads for the breechblock.

5. BREECH MECHANISM.

a. General. The function of the breech mechanism is to close the breech, and thereby hold the cartridge case in place. The breechblock is the main part of the mechanism. It closes the breech and is hinged so that it can be swung open for loading. It is moved by an operating lever. The lever and breechblock are connected by an operating bar, operating in a T-slot in the breechblock carrier. Thus connected, complete motion of the operating lever to the right will cause the breechblock to rotate and to be swung clear of the breech recess. Swinging the operating lever fully to the right engages cam surfaces of the breechblock carrier and extractor, causing the extractor to eject the empty cartridge case.

b. Principal Parts. The principal parts of the breech mechanism are: Breechblock, breechblock carrier, breechblock latch, operating bar, operating lever, extractor, hinge pin, extractor hinge pin (on the M1902MI gun only) and trigger shaft (figs. 3 and 4).

(1) **BREECHBLOCK.** The breechblock contains four threaded and four unthreaded sectors. A stud on the rear face of the breechblock engages the operating bar. Another stud on the rear face of breechblock limits its rotation.

(2) **BREECHBLOCK CARRIER.** The breechblock carrier swings about the hinge pin while carrying the breechblock in or out of the breech recess. A hub on the carrier is provided on which to mount the breech-

3-INCH SEACOAST GUN MATERIEL

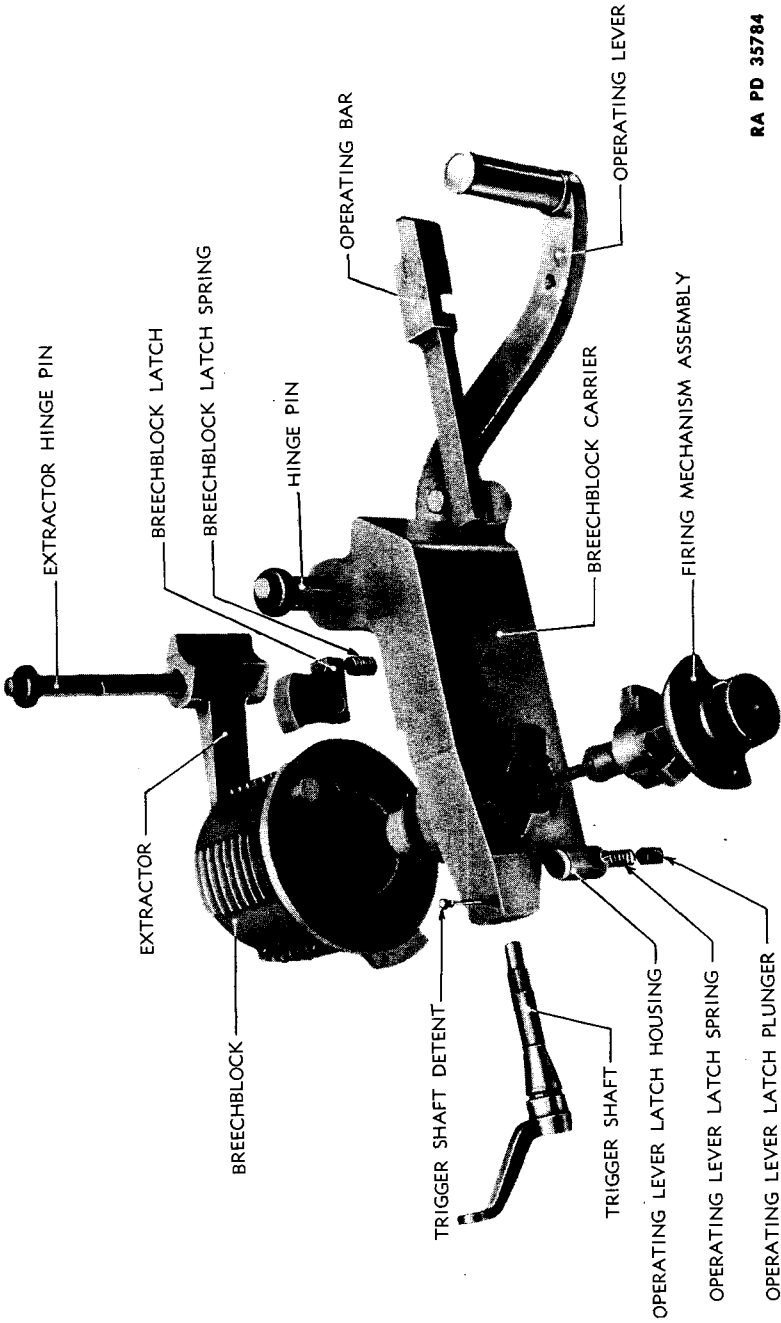

RA PD 35784

Figure 3—Breech Mechanism, M1902M1 Gun

DESCRIPTION OF GUNS

RA PD 35825

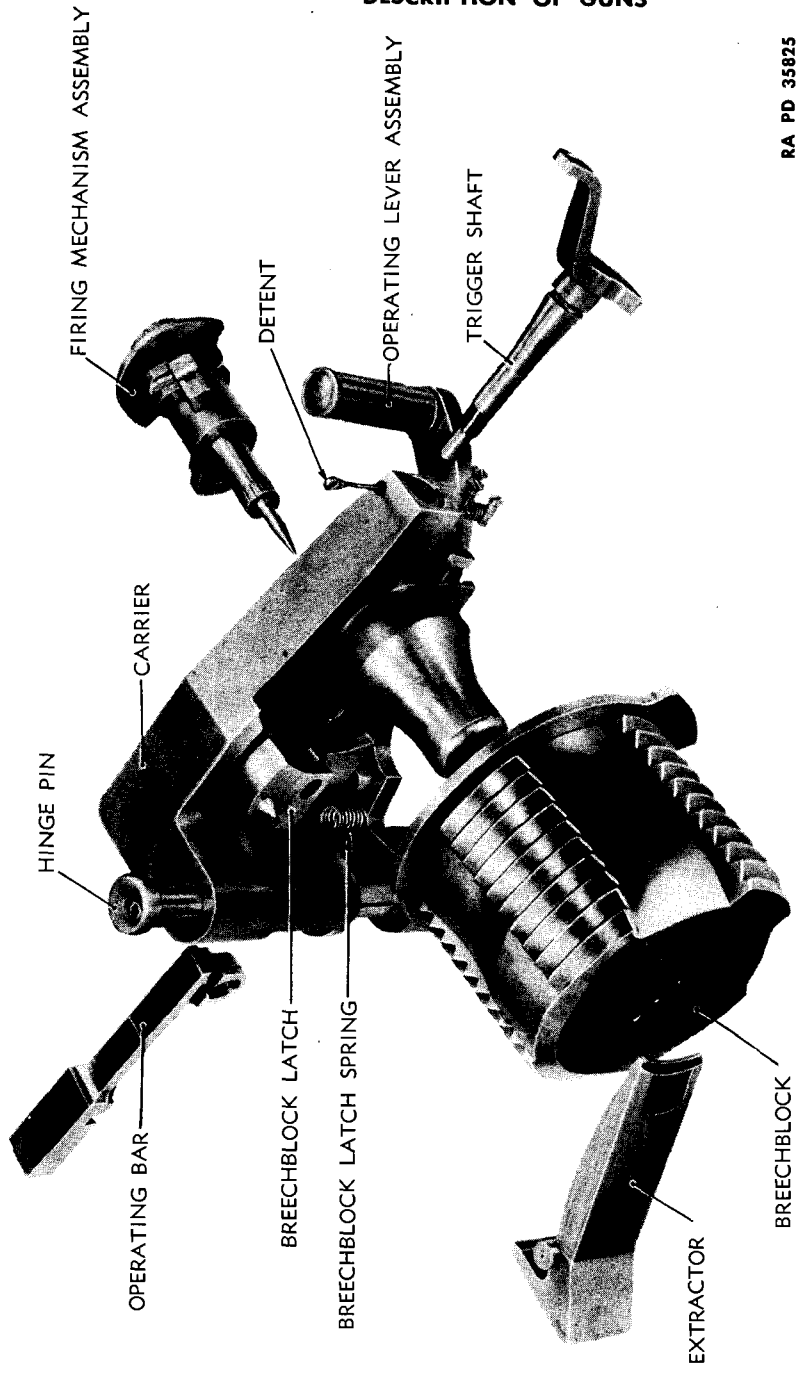

Figure 4—Breech Mechanism, M1903 Gun

3-INCH SEACOAST GUN MATERIEL

block. This hub also forms a seat for the firing case. The bottom of the carrier has a T-shaped cut to receive the operating bar. A hole is bored on the left side of the carrier to receive the trigger shaft.

(3) **BREECHBLOCK LATCH.** The breechblock latch operates on a pivot inserted in the carrier. A spring is placed in a pocket in the bottom of the latch which constantly presses the latch on the rim of the breechblock flange and engages the notch when the breech mechanism is open, thereby locking the breechblock against rotation when the threads of the breechblock are disengaged from those of the breech recess. When the carrier is closed against the breech of the gun, a conical point pin in the latch slides against a similar face in the breech of the gun, withdrawing the latch from the notch in the flange of the breechblock, and allowing the breechblock to rotate.

(4) **OPERATING LEVER.** The operating lever is hinged to the hinge pin directly underneath the breechblock carrier. A pin inserted in the top face of the lever engages a cam slot near the end of the operating bar.

(5) **OPERATING BAR.** The operating bar slides to the right and left in a T-shaped cut in the bottom of the carrier so as to engage a stud in the rear face of the breechblock, thus rotating the breechblock.

(6) **HINGE PIN.** The hinge pin connects the carrier and operating lever to the breech end of the gun.

(7) **EXTRACTOR.** The extractor is hinged on the extractor hinge pin. The inner arm of the extractor grasps the rim of the cartridge case. The outer arm has a cam surface which engages the cam surface on the carrier. These two cam surfaces are shaped so as to give the extractor an accelerating movement, thus ejecting the cartridge case clear of the gun.

(8) **EXTRACTOR HINGE PIN.** The extractor hinge pin connects the extractor on the right side of the gun near the breech end. The M1903 gun has no extractor hinge pin.

(9) **TRIGGER SHAFT.** The trigger shaft is pivoted in a bearing in the left side of the breechblock carrier; a split-pin detent, engaging a groove in the trigger shaft, prevents it from working out of the side. A projecting arm engages the flange on the breechblock, thus preventing any movement to the trigger shaft until the breechblock has been closed. An eye for the lanyard hook is provided in the upper arm. The small bearing end of the trigger shaft is squared to fit the cocking lever.

6. FIRING MECHANISM.

a. **General.** The firing mechanism (fig. 5) is known as the continuous pull, percussion type; that is, no cocking of the firing pin is required other than a pull on the lanyard or trigger shaft. This arrangement permits repeating the blow from the firing pin in case of a misfire

DESCRIPTION OF GUNS

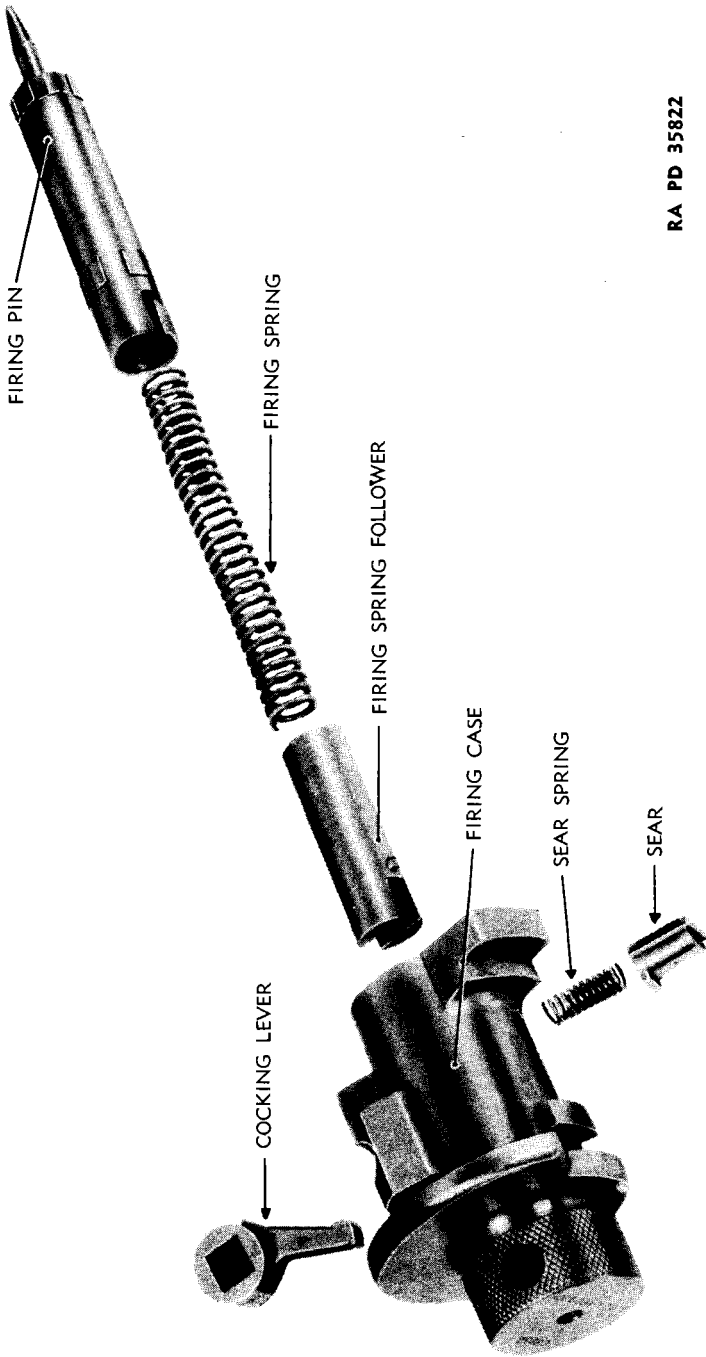

RA PD 35822

Figure 5—Firing Mechanism

3-INCH SEACOAST GUN MATERIEL

as often as desired without opening the mechanism or recocking the firing pin. The mechanism consists principally of the following parts: Firing case, firing pin, firing spring, firing-spring follower, sear, sear spring, and cocking lever.

b. Firing Case. The firing case contains the complete firing mechanism, and can be replaced in an instant. It has three lugs which lock it in place in the hub of the breechblock carrier. Another lug, which is forward of the other three, engages the spiral groove in the breechblock; the four lugs locking the breechblock and carrier together. Displacement of the firing case is prevented by the trigger shaft. Through the bottom of the firing case near the center, a hole is bored and slotted through which the sear and sear spring are passed to their seats on the opposite side of the firing case. To the rear of this seat is a rectangular slot cut through to the center. This slot forms a clearance pocket and seat for the cocking lever to engage.

c. Firing Pin. The firing pin is mounted in the firing case and has projecting surfaces on its exterior which serve to guide the pin axially. The forward end of the firing pin is reduced in diameter to provide a shoulder which engages the bottom of the sear in the breechblock carrier, limiting the amount of travel forward when fired. It is bored out in the center to receive the firing spring and firing-spring follower. At the rear end a rectangular slot is cut through the firing pin which provides a web against which the cocking lever engages at a point between its lower end and its axis. This engagement serves to withdraw the firing pin to its retracted or normal position after the pin has been released and forced forward. Opposite this slot there is another narrow groove in which the projecting pin of the firing-spring follower travels. This connection to the firing pin, firing spring and firing-spring follower facilitates assembling and disassembling. A little forward of this rectangular slot another opening is cut which serves as a seat for the engagement of the sear.

d. Firing Spring. The firing spring is made of such length that when assembled inside of the firing pin and firing-spring follower it will be under an initial compression.

e. Firing-Spring Follower.

(1) The firing-spring follower slides inside the firing pin. This firing-pin follower has a pin projecting which engages a groove in the firing pin and serves to guide it.

(2) The closed end is slotted to receive the end of the cocking lever with which it engages.

DESCRIPTION OF GUNS

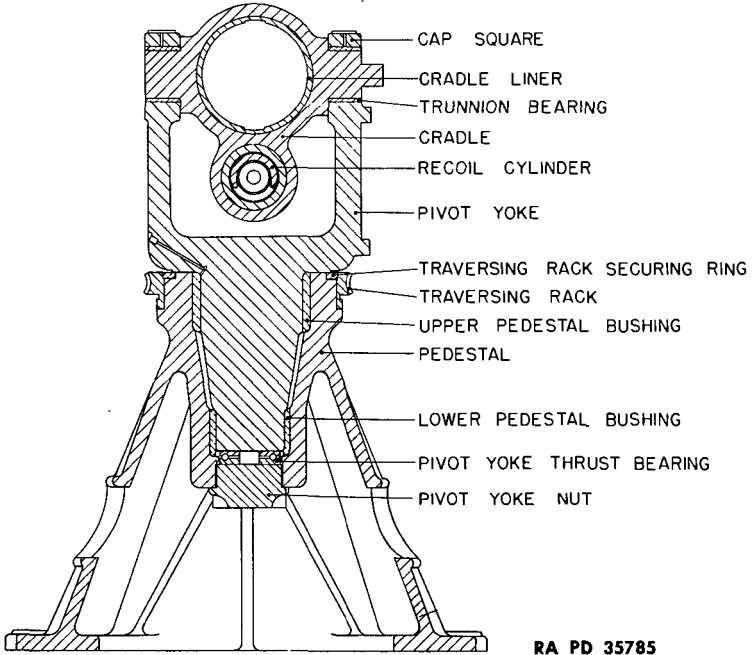

Figure 6—Sectional Schematic, M1902 Carriage

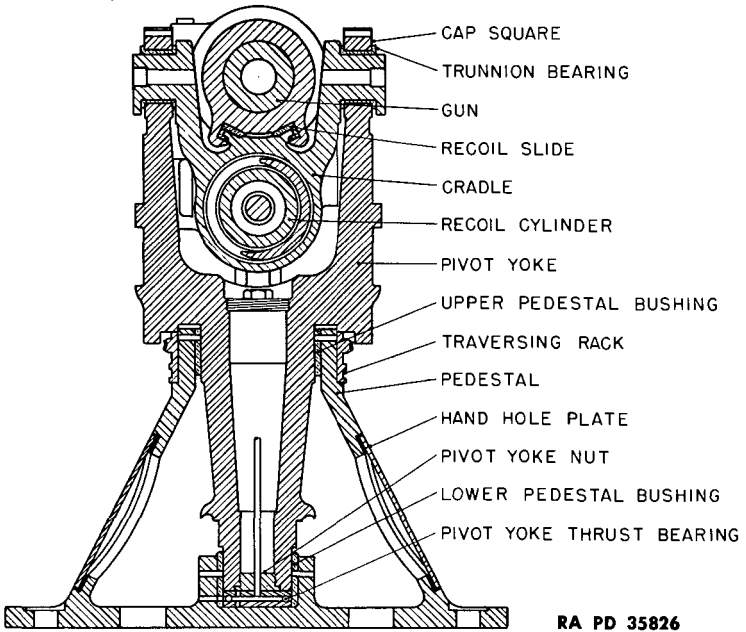

Figure 7—Sectional Schematic, M1903 Carriage

3-INCH SEACOAST GUN MATERIEL

f. **Sear.** The sear is designed so that one end engages the seat cut into the firing pin, thus holding the firing pin until released. At the other end of the sear a rectangular projection is formed which the cocking lever engages during its rotation, releasing the firing pin after the spring has been compressed. The center is drilled to receive the sear spring, which is assembled so as to cause the sear to press against the firing pin.

g. **Sear Spring.** The sear spring is a small coiled spring with a projection on one end. This projection engages a small hole drilled in the sear, and prevents the spring from falling out of the sear when the parts are being assembled.

h. **Cocking Lever.** The cocking lever is seated in the rear end of the firing case and is prevented from lateral displacement by the walls of the case. It is mounted on the square end of the trigger shaft. The cocking lever passes through the rectangular slot cut in the rear end of the firing pin, engaging the firing pin and firing-spring follower.

Section II

DESCRIPTION OF CARRIAGES

	Paragraph
General	7
Recoil and counterrecoil mechanism	8
Elevation mechanism	9
Traversing mechanism	10
Range indicators	11
Electrical equipment	12

7. GENERAL.

a. The gun carriage consists of a pedestal, bolted rigidly to the concrete emplacement, and of a gun-supporting structure, which rests on the pedestal and is capable of traversing upon it. The pedestal is the foundation piece of the carriage. On the M1902 carriage the pivot yoke is mounted in the pedestal and rests upon a ring of ball bearings placed upon the pivot yoke nut (fig. 6). On the M1903 carriage the pivot yoke is mounted in the pedestal and rests upon a ring of ball bearings on the base of the pedestal (fig. 7). The entire weight of the gun and top part of the carriage rests upon this ring of ball bearings. The bushings for the pivot yoke form two supports against the thrust of firing. At the upper end of the pivot yoke, on either side, trunnion bearings are provided for the cradle trunnions. The shield and shield supports are bolted to the pivot yoke. The opening for the gun in the shield is prolonged underneath to allow for the removal of the piston and springs from the recoil cylinder.

b. The carriage consists of recoil and counterrecoil mechanism, elevation mechanism and traversing mechanism. In addition, the M1902 carriage has a range disk and the M1903 has a range drum.

c. A recoil cylinder checks the recoil of the gun, and a spring inside the recoil cylinder returns the gun to battery.

(1) On the M1902 carriage a traversing locking device, in its unlocked position, allows the piece to be traversed freely without the use of the traversing handwheel. In its locked position, traverse is accomplished only by use of the traversing handwheel.

(2) On the M1903 carriage a friction band is provided and is adjusted so as to allow a certain amount of friction between itself and the traversing rack.

3-INCH SEACOAST GUN MATERIEL

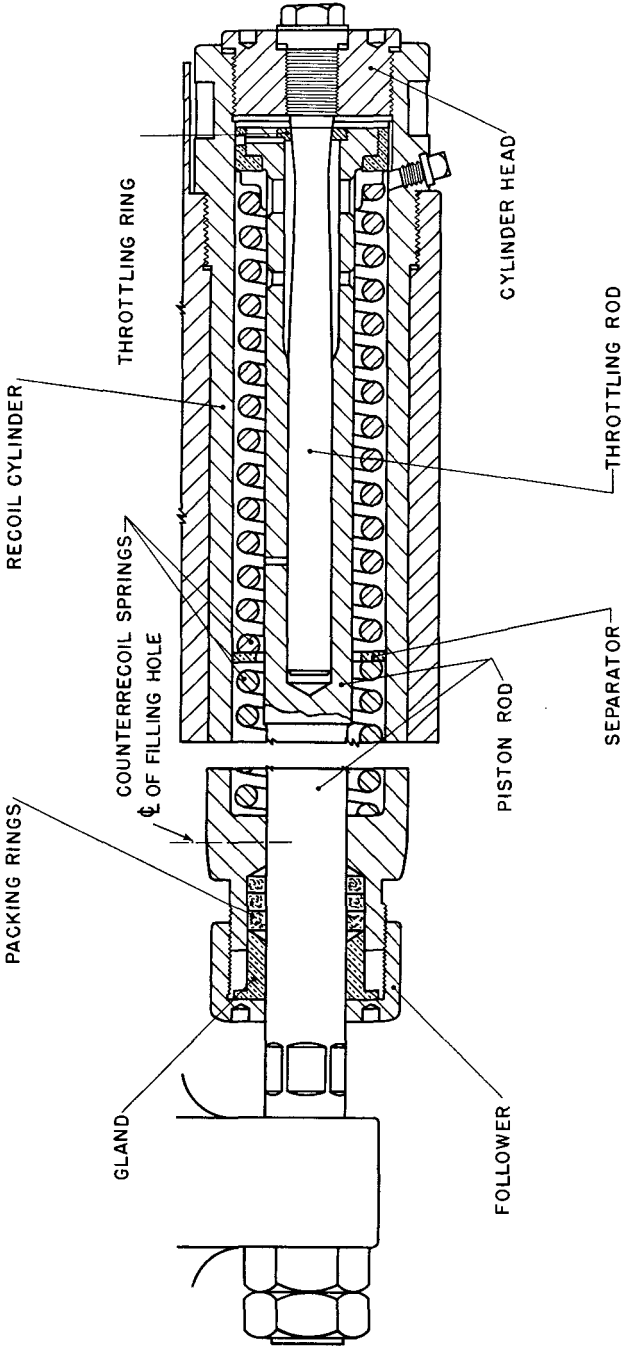

RA PD 35786

Figure 8—Recoil and Counterrecoil Mechanism, M1902 Carriage

DESCRIPTION OF CARRIAGES

8. RECOIL AND COUNTERRECOIL MECHANISM.

a. **General.** The recoil of the piece is checked by a hydraulic cylinder and by the resistance from the compression of the counter-recoil spring.

b. **M1902 Carriage.** The recoil cylinder is screwed into the forward part of the recoil cylinder sleeve in the cradle. The front end of the cylinder is closed by a cylinder head provided with a gasket. A throttling rod extending into the bore of the piston rod is screwed into the cylinder head. The rear end of the cylinder has a stuffing box for the piston rod, consisting of a follower, a gland, and three packing rings. The threads for the followers are on the exterior of the cylinder and do not interfere with the removal or replacement of the packing (fig. 8).

(1) Counterrecoil is effected by a coiled spring in two sections with a separator between them. This spring bears against the piston in front and against a shoulder of the recoil cylinder in the rear.

(2) In recoil, throttling of the oil in the cylinder is effected by the passage of the oil through holes and through the clearance between the throttling rod and the throttling ring, which clearance is made by varying diameters of the rod, so as to maintain a constant pressure in the oil in the cylinder during recoil (fig. 9).

(3) In counterrecoil, the oil caught in the hollow piston rod is forced by the throttling rod through holes and through the clearance between the throttling rod and the walls of the hollow piston rod, and through a hole from the bottom of the bore in the piston rod, thus checking the velocity of counterrecoil. The end of the piston rod passes through a lug on the gun and is secured by a nut and lock nut (fig. 9).

c. **M1903 Carriage.** The counterrecoil spring is a single helical spring, assembled from the front. The rear end rests against a flange on the interior of the spring cylinder and the forward end rests against a flange on the front recoil cylinder head. The counterrecoil spring is coiled between the interior of the spring cylinder and the exterior of the recoil cylinder (fig. 10).

(1) The recoil cylinder is threaded at the ends to receive the front and rear recoil cylinder heads. The front and rear ends of the recoil cylinders are made oil tight by flexible vulcanized fiber packings. The piston rod passes through a stuffing box in the front recoil cylinder head.

(2) The stuffing box consists of a follower on the piston rod, screwed into a box in the front recoil cylinder head. This compresses five rings of Garlock's hydraulic waterproof packing between a flange in the box and a gland. This gland is divided in two halves and retained in position on the follower by a ring.

(3) The front cylinder head has both a filling and a drain hole, each closed by a filling and drain plug.

3-INCH SEACOAST GUN MATERIEL

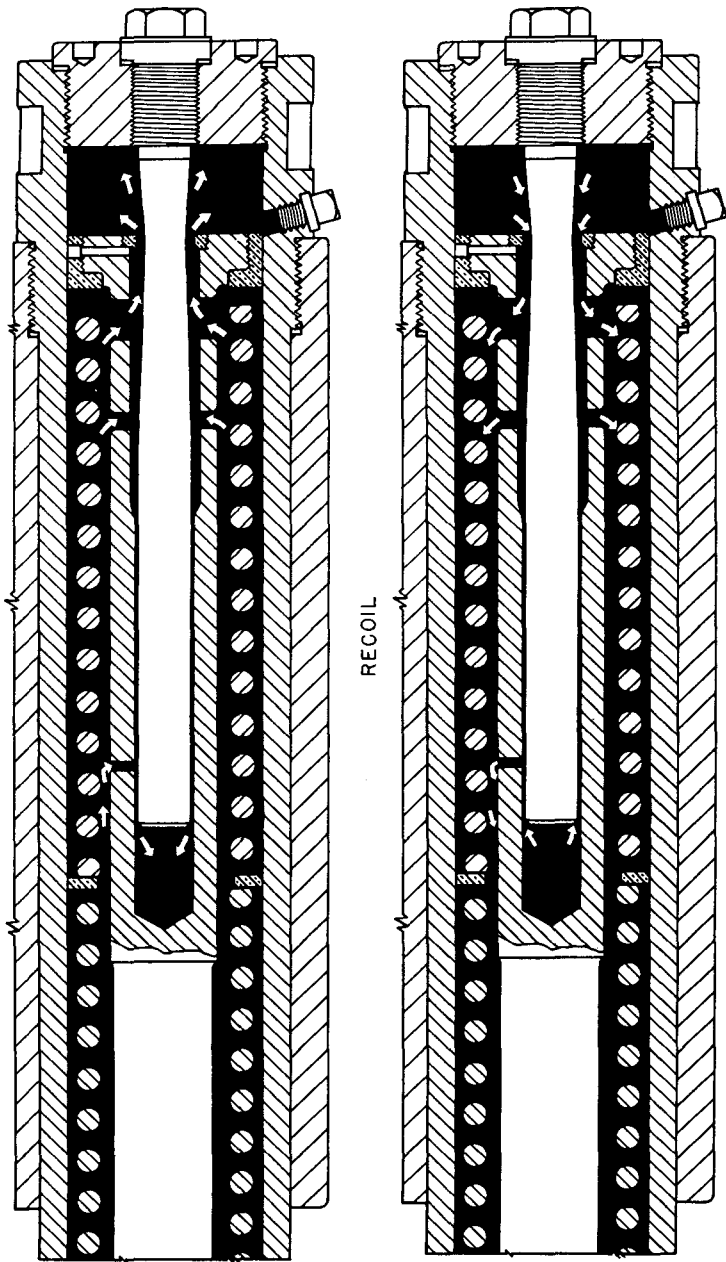

RA PD 35787

COUNTERRECOIL

Figure 9—Flow of Oil in Recoil and Counterrecoil Mechanism, M1902 Carriage

DESCRIPTION OF CARRIAGES

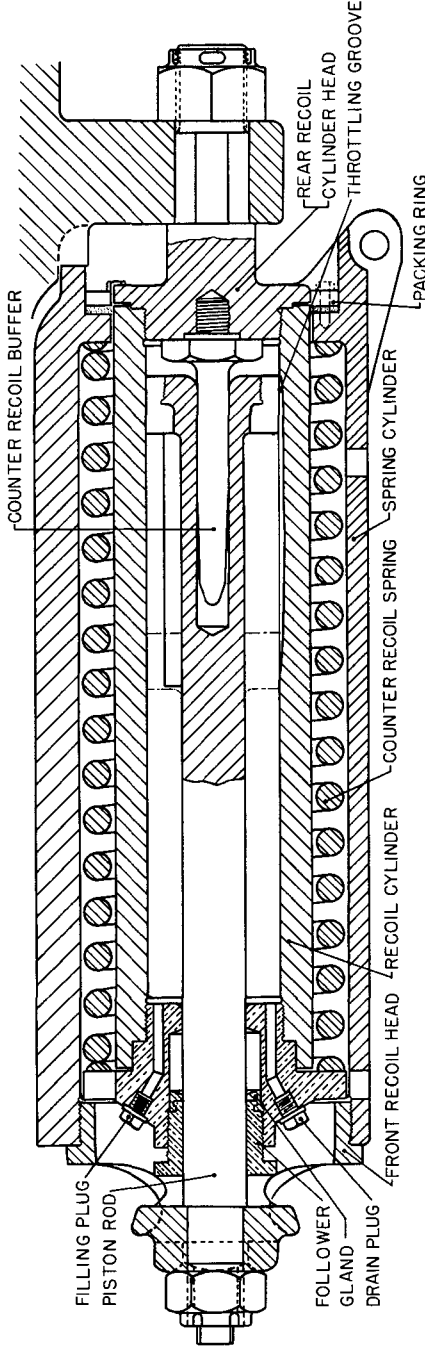

RA PD 35827

Figure 10—Recoil and Counterrecoil Mechanism, M1903 Carriage

3-INCH SEACOAST GUN MATERIEL

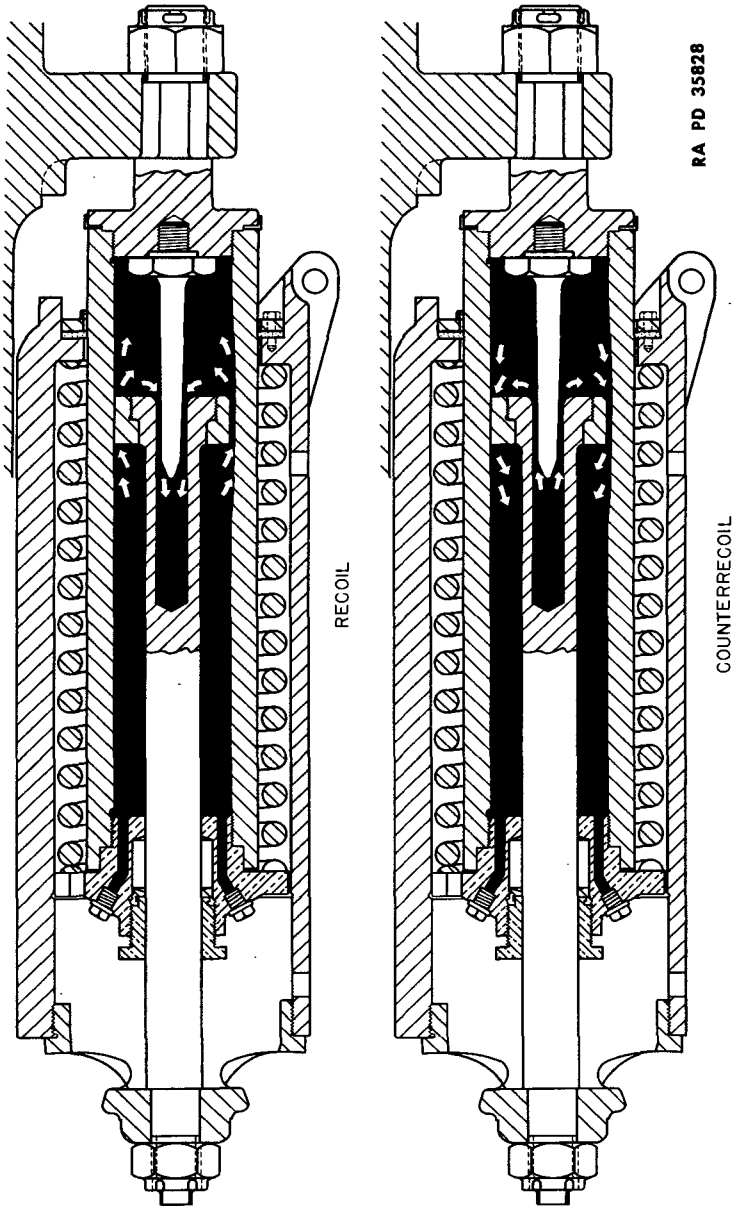

Figure 11—Flow of Oil in Recoil and Counterrecoil Mechanism, M1903 Carriage

DESCRIPTION OF CARRIAGES

(4) The spring cylinder head receives the piston rod pull and also the thrust of the counterrecoil spring at assembled height, when the lug of the gun is disconnected from the rear cylinder head stud, in mounting and dismounting the recoil system. The instruction plate is mounted on the right side of the pivot yoke.

(5) The piston rod and piston is one piece and form a part of the counterrecoil buffer system. The counterrecoil buffer is threaded and screwed into the rear recoil cylinder head from the inside.

(6) Three throttling grooves are in the interior of the recoil cylinder.

(7) The action of the gun is as follows: When fired, the gun recoils about 9 inches in the cradle, carrying with it the recoil cylinder, and thereby compressing the counterrecoil spring. A small portion of the energy of recoil is taken up in compressing the counterrecoil spring, but the greater portion of the energy is absorbed by the resistance offered by the liquid being forced through the orifices of the throttling grooves. The counterrecoil buffer is tapered so that the escape of oil during counterrecoil through clearances between the buffer and the walls of its hole will offer such resistance as will control the motion of the gun during its return, and finally bring it to rest when the recoil piston reaches the rear end of the cylinder (fig. 11).

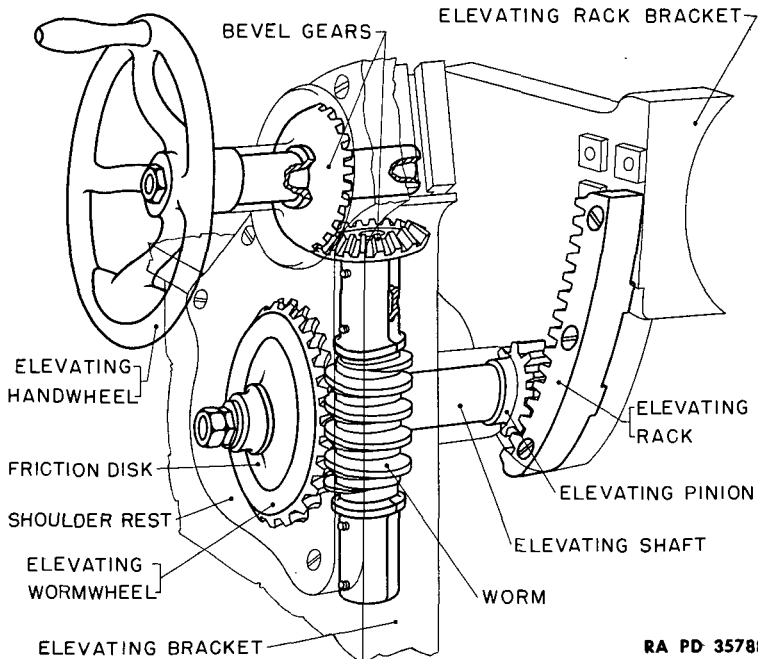

RA PD 35788

Figure 12—Elevation Mechanism, M1902 Carriage

3-INCH SEACOAST GUN MATERIEL

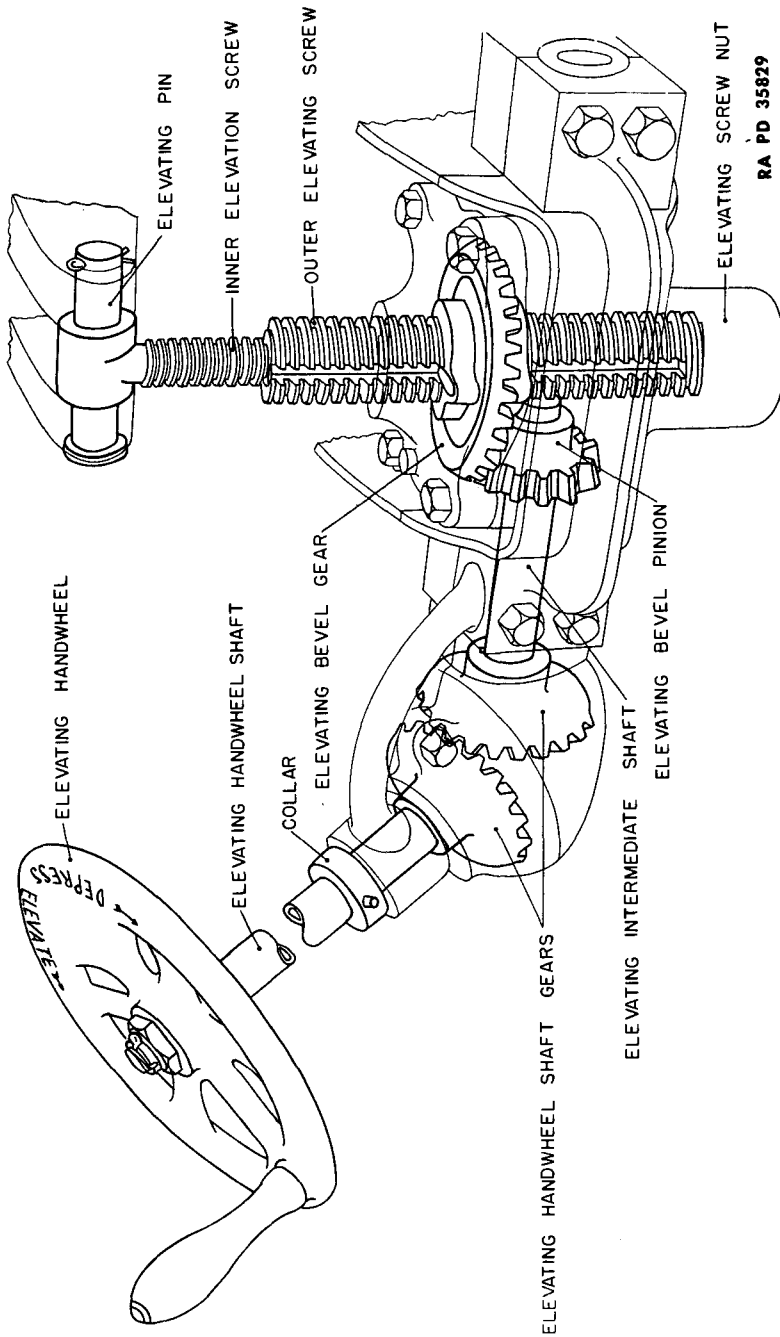

Figure 13—Elevation Mechanism, M1903 Carriage

DESCRIPTION OF CARRIAGES

9. ELEVATION MECHANISM.

a. M1902 Carriage.

(1) The elevating bracket is bolted to the left side of the pivot yoke. It carries the elevation mechanism, with the exception of the elevating rack. The elevating pinion and shaft has its bearings in the elevating bracket and the shoulder rest. Two friction disks are placed on the outer end of the shaft, the inner one bearing against a shoulder on the shaft and the outer one against the nut at the end of its shaft. The device allows slipping between the worm wheel and the disks, and is designed to prevent injury to the elevating mechanism due to the shocks of firing (fig. 12).

(2) The shoulder rest forms a cover for the elevating worm wheel, worm, and mechanism. The elevating worm shaft has its bearing half in the elevating bracket and half in the shoulder rest. The elevating handwheel is placed on the squared end of the elevating handwheel shaft and is held by a nut.

b. M1903 Carriage.

(1) The elevation mechanism consists of a handwheel which actuates through suitable connecting shafts and bevel gears, a double screw with right-hand outer threads and left-hand inner threads. The inner screw has a left-hand thread and has its upper end attached to the lug on the bottom of the rear end of the spring cylinder. The elevating screw nut is pivoted on trunnions so as to allow the necessary rotation, corresponding to different angles of elevation. The elevating screw nut is provided with an elevating screw nut cap bolted to it. The elevating screw cap has an oil hole and plug, and the elevating screw nut has a hole fitted with a plug for draining (fig. 13).

(2) The pinion is keyed to the intermediate elevating shaft, which receives its motion from the handwheel by the elevating handwheel shaft and a set of elevating handwheel shaft gears.

(3) The elevating handwheel shaft has a bearing near the handwheel in a bracket secured to the shoulder rest. The elevating gear bracket cap has a bearing for the lower end of the elevating handwheel shaft and serves as a cap for the trunnions of the elevating screw nut.

10. TRAVERSING MECHANISM.

a. M1902 Carriage.

(1) The traversing worm is placed at the rear of the pivot yoke and meshes in the traversing rack. The shaft has its bearings half in the pivot yoke and half in the worm cover bracket bolted to the pivot yoke. At the end of the traversing worm shaft is a traversing pinion meshing in a similar one placed at the end of the traversing shaft. This shaft is provided with a handwheel at the rear end (fig. 14).

(2) At the front of the pedestal is a clamp consisting of a block, two

3-INCH SEACOAST GUN MATERIEL

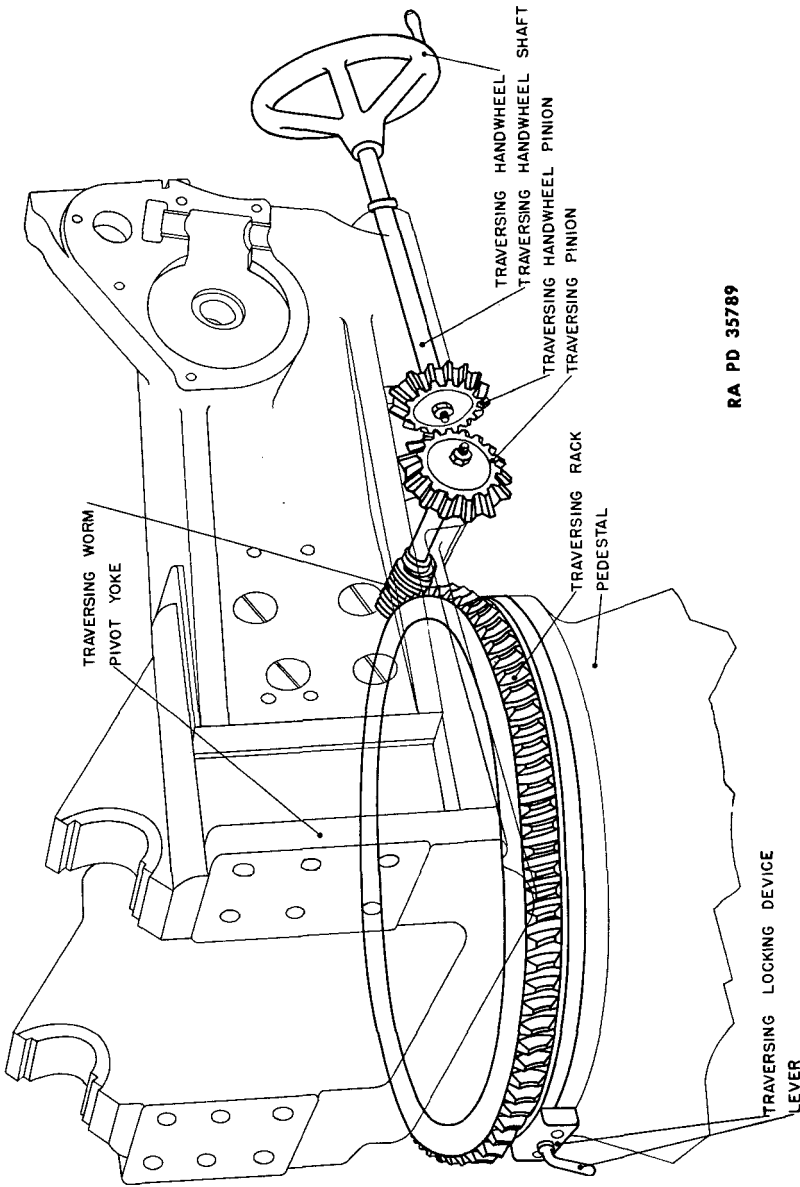

RA PD 35789

Figure 14—Traversing Mechanism, M1902 Carriage

DESCRIPTION OF CARRIAGES

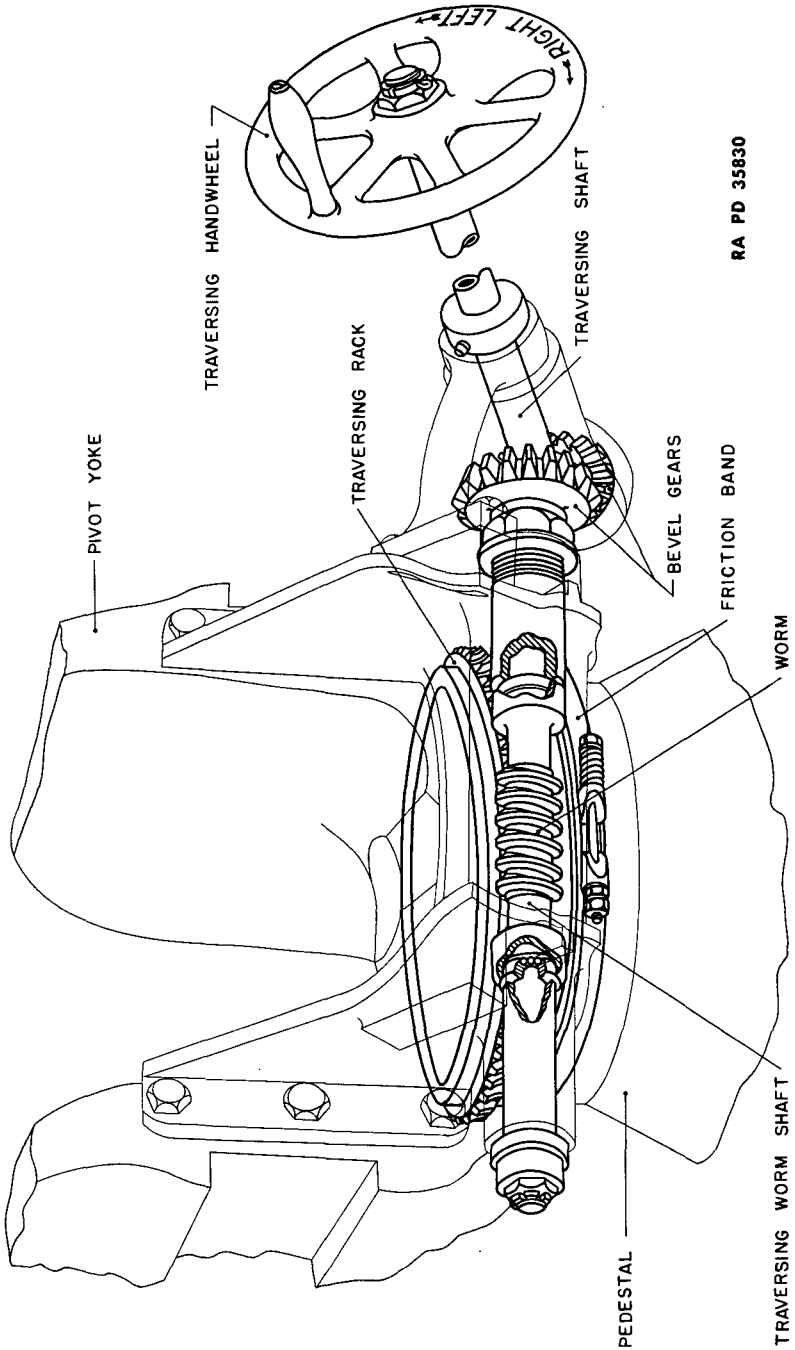

RA PD 35830

Figure 15—Traversing Mechanism, M1903 Carriage

3-INCH SEACOAST GUN MATERIEL

guide studs, a clamping screw, and lever. By means of this assembly the traversing rack may be clamped to the pedestal. The object of having the traversing rack clamped by friction to the pedestal, instead of being rigidly attached to it, is to prevent undue strains on the traversing mechanism in case of rapid traversing and sudden stopping, in which case the friction arrangement allows slipping between the traversing rack on the pedestal. In case very rapid traversing is desired, the traversing rack may be unclamped and the gun traversed by pushing on the breech or muzzle end (fig. 14).

b. M1903 Carriage.

(1) The traversing mechanism consists of the traversing rack, traversing worm shaft and worm, one pair of bevel gears, one traversing shaft, and one traversing handwheel. The traversing rack is seated on the exterior cylindrical top of the pedestal, and is retained in position by the friction band, a shoulder on the pivot yoke, and a shoulder on the pedestal (fig. 15).

(2) The friction band is made in halves which are united by a stud bolt screwed into the front of the pedestal. A certain amount of friction between the traversing rack and the friction band must be permitted, but the traversing rack must be bolted to the pedestal rigidly enough to allow the thrust of the traversing worm shaft to traverse the gun. This adjustment must not be so rigid that the teeth of the traversing rack might be injured by the sudden shock of firing.

(3) A pair of bevel gears serves to transmit the motion of the traversing handwheel and traversing handwheel shaft to the end of the traversing worm shaft. The traversing handwheel shaft is supported in its proper position by two brackets containing suitable bearings. One bracket is bolted to the elevating gear bracket and the other to the shoulder rest.

11. RANGE INDICATORS.

a. **Range Disk for the M1902 Carriage.** This disk, attached to the left side of the carriage, is graduated in yards of range and degrees of elevation. A pinion on the disk engages in a rack attached to the cradle; the movement of the rack when the gun is elevated or depressed turns the disk. A spring on the interior of the disk takes up the backlash in the rack and pinion. The range index has a micrometer screw for small adjustments (fig. 16).

b. **Range Drum for the M1903 Carriage.** This drum is attached to the left side of the carriage, which is graduated to ranges in yards and elevation in degrees. A pinion on the drum engages in a rack attached to the cradle; the movement of the rack when the gun is elevated or depressed turns the drum through the pinion. A spiral spring on the interior of the drum is provided to take up the backlash in the rack and pinion (fig. 17).

DESCRIPTION OF CARRIAGES

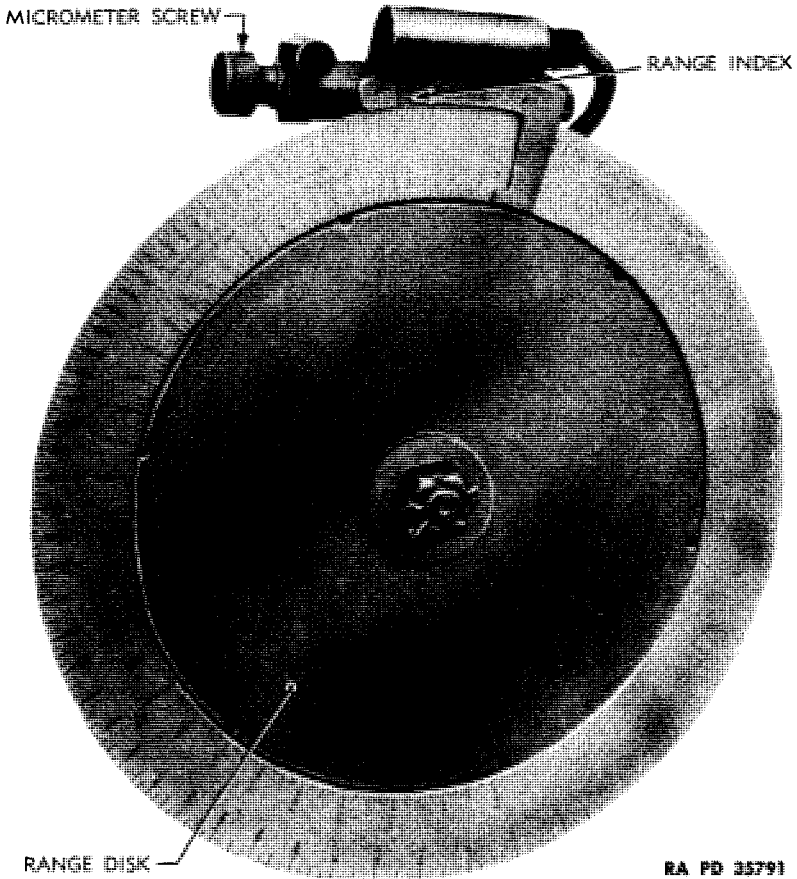

Figure 16—Range Disk, M1902 Carriage

12. ELECTRICAL EQUIPMENT.

a. **General.** The electrical equipment on the M1902 and M1903 carriages consists of the lighting circuit. Power for the lighting circuit is supplied by a storage battery.

b. **M1902 Carriage.** The storage battery is placed in a box which is bracketed to the left side of the carriage just back of the shield. Cables run from the battery to the following outlets: The deflection scale lamp, the telescope lamp, the range disk lamp, and the night sight lamp. The storage battery furnishes the 6-8 volts required at the lamp terminals (fig. 18).

c. **M1903 Carriage.** The storage battery is placed in a box bracketed to the right side of the carriage just back of the shield. Cables run

3-INCH SEACOAST GUN MATERIEL

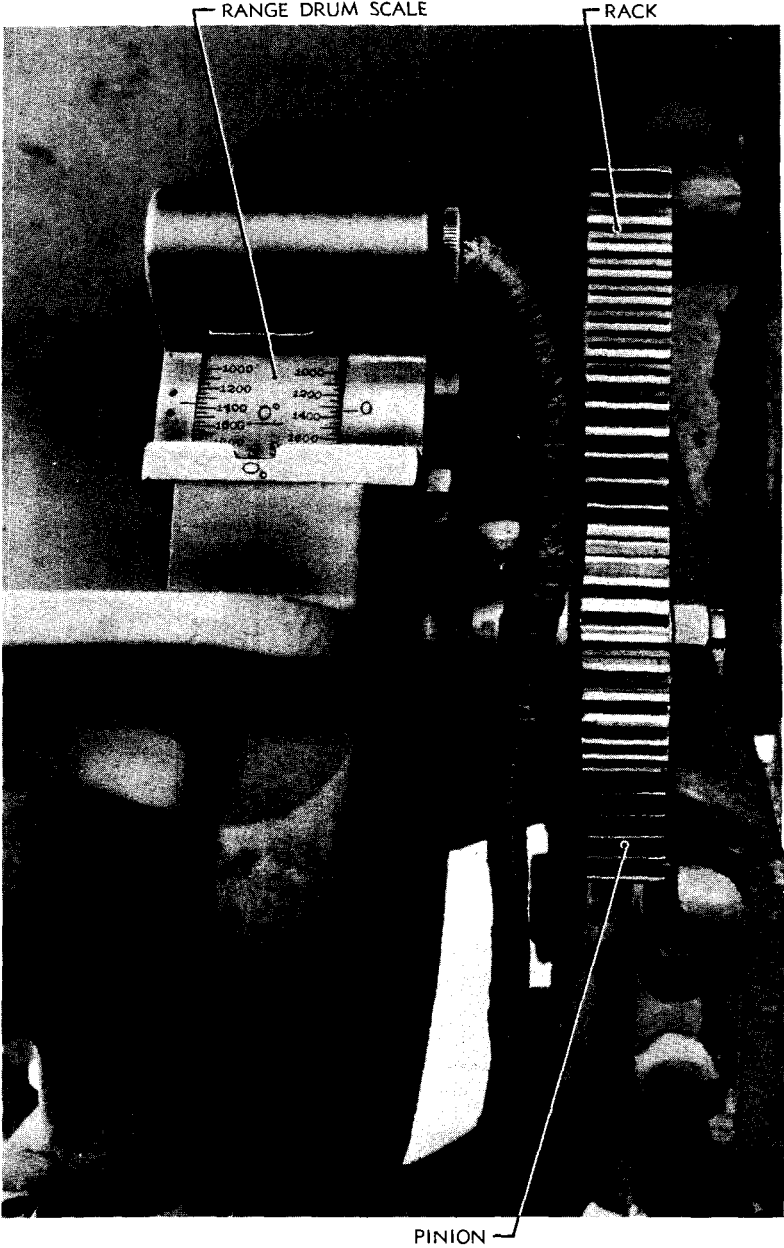

RA PD 35831

Figure 17—Range Drum, M1903 Carriage

DESCRIPTION OF CARRIAGES

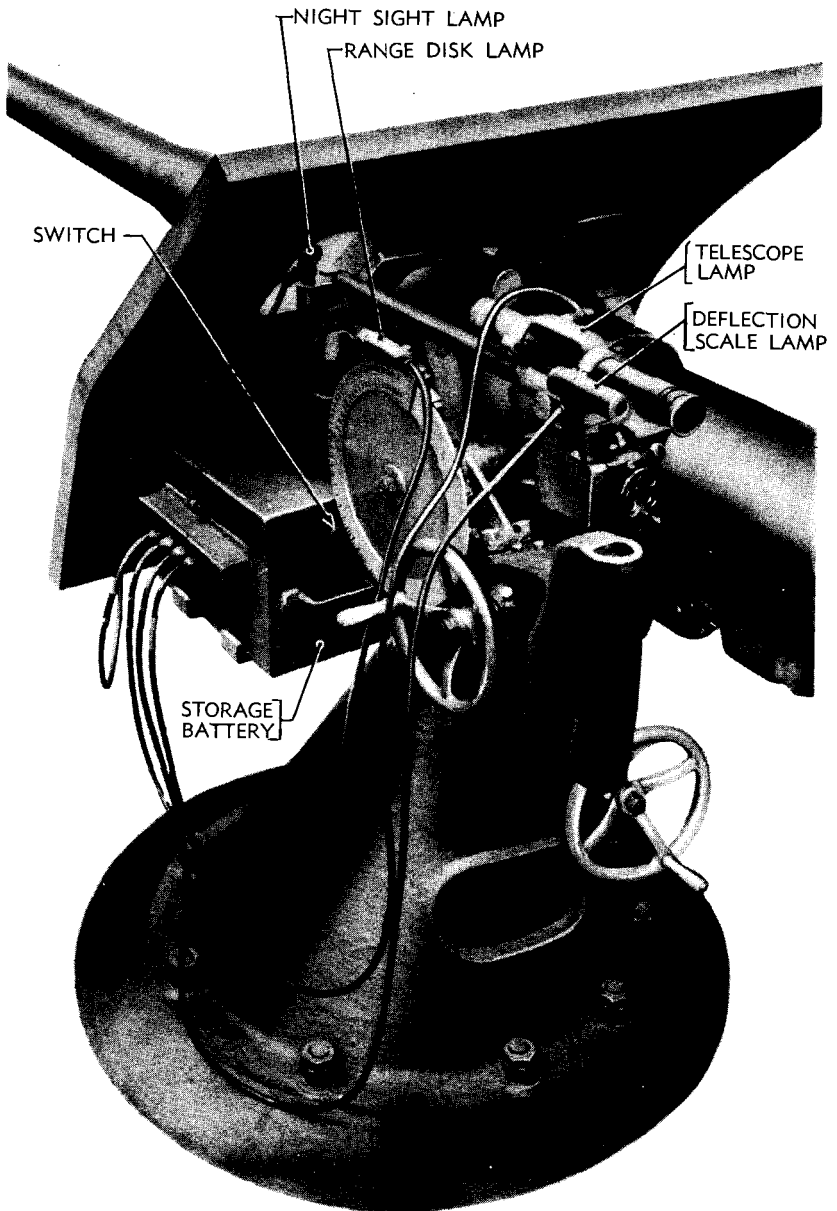

RA PD 35793

Figure 18—Lighting Circuit, M1902 Carriage

3-INCH SEACOAST GUN MATERIEL

from the battery to the following outlets: The night sight lamp, deflection scale lamp, and the range drum lamp. The storage battery furnishes the 6-8 volts required at the lamp terminals (fig. 19).

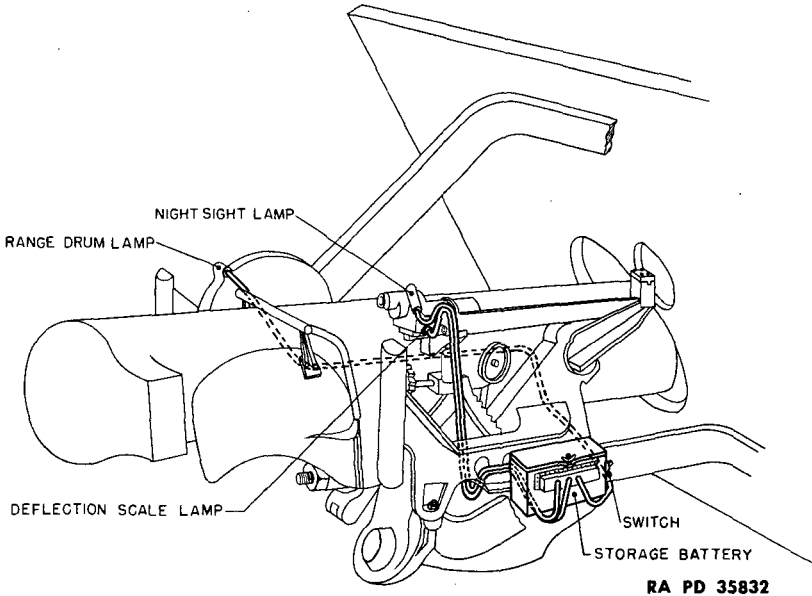

Figure 19—Improved Lighting Circuit, M1903 Carriage

NOTE: The above lighting circuit is the improved type for use in the 3-inch (15-pdr.) barbette carriages M1903. Some M1903 carriages are not yet equipped with this improved lighting circuit. Those not so equipped are using the emplacement main as the source of power for lighting.

Section III

OPERATION

	Paragraph
General	13
To operate	14
Points to be observed before firing	15
Points to be observed during firing	16

13. GENERAL.

Only information necessary for the operation of the M1902 and M1903 guns and carriages are included in this section. For detailed information regarding the duties of the gun section, see FM 4-90.

14. TO OPERATE.

a. **To Open the Breech.** Swing the operating lever to the right. This movement rotates the breechblock and swings it clear of the breech recess.

b. **To Close the Breech.** Swing the operating lever to the left until the lever latch seats itself and further motion is impossible.

c. **To Elevate and Depress.** Rotate the elevation handwheel in the direction indicated on the handwheel (figs. 20 and 21).

d. **To Traverse.** Rotate the traversing handwheel in the direction indicated on the handwheel for left or right traverse (figs. 22 and 23).

e. **To Load.** The ammunition for this gun is fixed and of a weight that can be handled entirely by hand. The ammunition is brought from the magazine to the gun and held ready for loading. To load, push the shell home into the breech recess of the gun with a moderately quick motion of the hand. Close the breech.

f. To Fire.

(1) **M1902MI GUN.** Attach the lanyard to the trigger shaft. Lay the gun on the target. Pull the lanyard directly to the rear (fig. 24).

(2) **M1903 GUN.** This gun is fired either by firing lever or by lanyard; the firing lever being the primary method. Lay the gun on the target. Pull either the firing lever or lanyard directly to the rear (fig. 25).

15. POINTS TO BE OBSERVED BEFORE FIRING.

a. **Lubrication.** All points should be thoroughly lubricated as prescribed (par. 23). The recoil cylinder should be filled to proper capacity (par. 19).

3-INCH SEACOAST GUN MATERIEL



RA PD 35799

Figure 20—Elevating the M1902MI Gun

OPERATION



RA PD 35838

Figure 21 —Elevating the M1903 Gun

3-INCH SEACOAST GUN MATERIEL

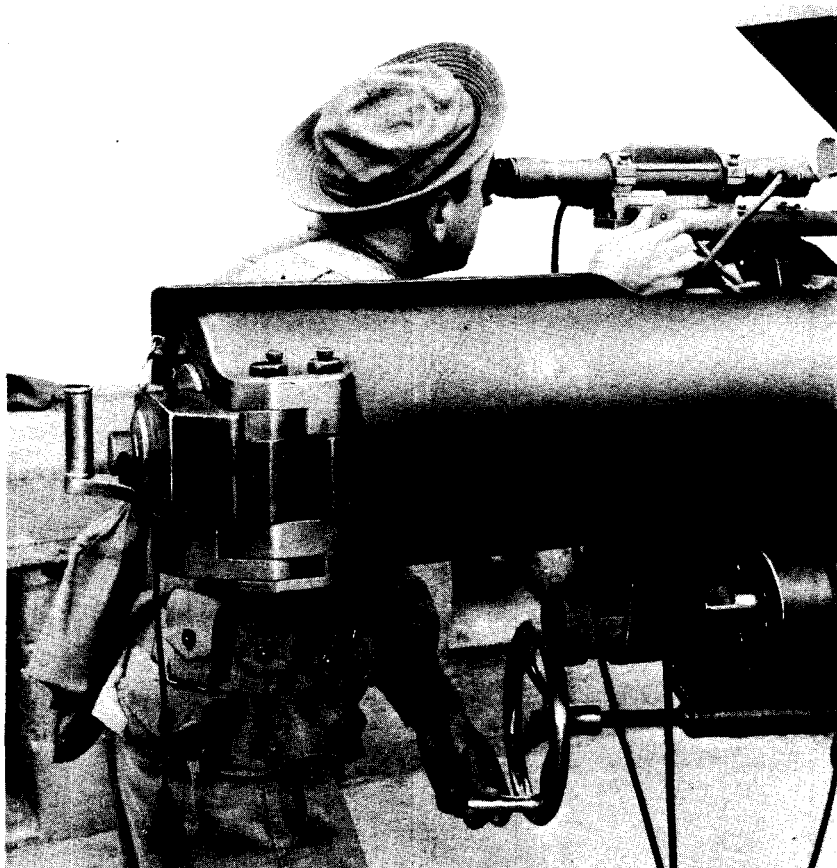

RA PD 35800

Figure 22—Traversing the M1902MI Gun

b. Preparation for Measuring Recoil. Attach a temporary index pointer to the top front end of the cradle. The surface of the gun should be chalked so that the index may scribe the length of recoil.

16. POINTS TO BE OBSERVED DURING FIRING.

a. Caution. If the gun fails to fire when the lanyard (on either gun) or the firing lever (M1903 gun, only) is pulled, the following safety precautions must be observed:

- (1) Stand clear of the path of recoil.
- (2) Keep the gun at firing elevation. Do not depress the piece.
- (3) Keep the gun directed in traverse either on the target or on a safe place in the field of fire.

OPERATION

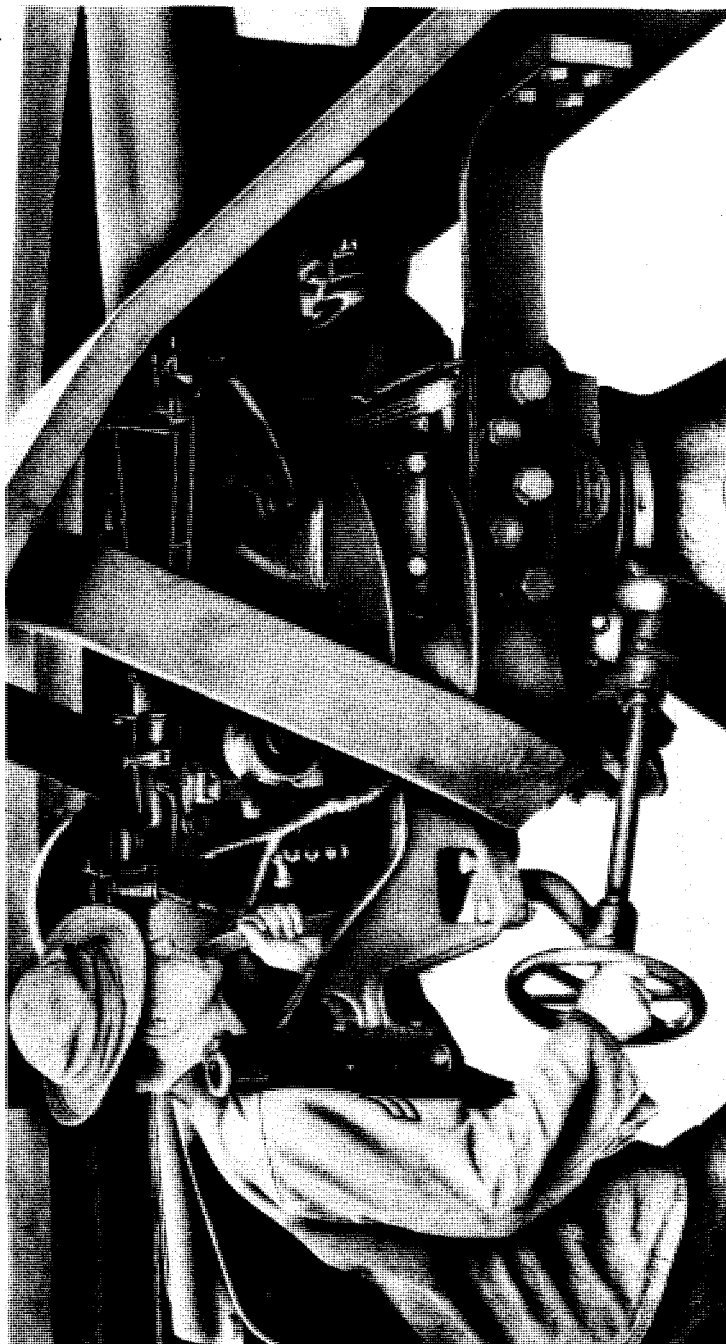

RA PD 35839

Figure 23—Traversing the M1903 Gun

3-INCH SEACOAST GUN MATERIEL

(4) The breech will not be opened until at least ten minutes after the last unsuccessful attempt to fire the piece.

(5) If firing a high explosive shell in peace time, all members of the gun section will be required to take shelter each time the piece is fired.

b. To Measure the Recoil. Normally the length of recoil will be checked after each round is fired. If the amount of recoil is in excess of 9 inches, and the cylinder is filled with the proper amount of recoil oil (par. 19), it would indicate a dangerous condition of the materiel. Stop firing. Notify ordnance maintenance personnel.

c. Protrusion of the Firing Pin.

(1) **M1902MI GUN.** It should be noted each time the breech is opened, during firing, whether or not the firing pin protrudes past the front face of the breechblock. If it does, the order should be given to cease firing. This condition indicates that the firing pin has not been cocked. Closing the breech at this time may cause the ammunition to explode before the breech is fully closed, endangering lives and/or damaging the piece.

(2) **M1903 GUN.** Protrusion of the firing pin has been guarded against on the M1903 gun; however, frequent inspection should be made to see that the point of the firing pin has not been broken or jammed.

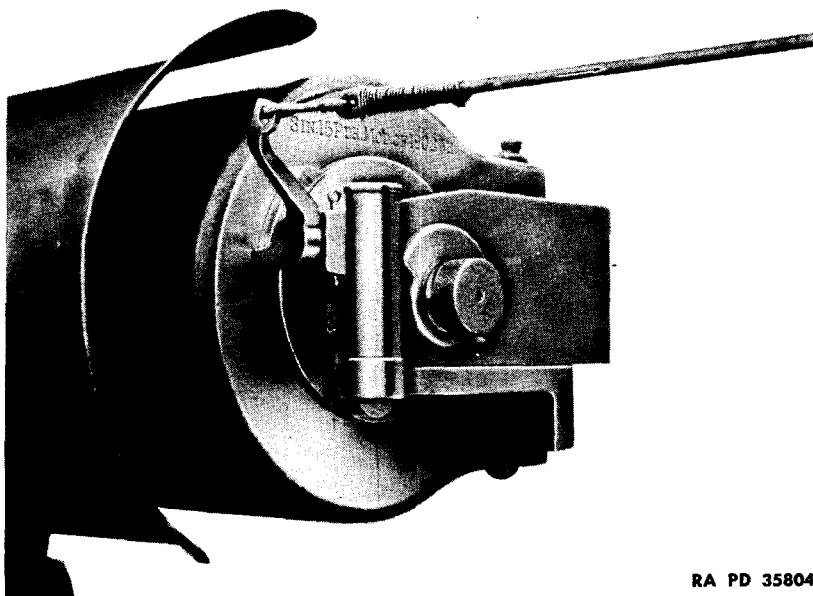

RA PD 35804

Figure 24—Firing Gun by Lanyard

OPERATION

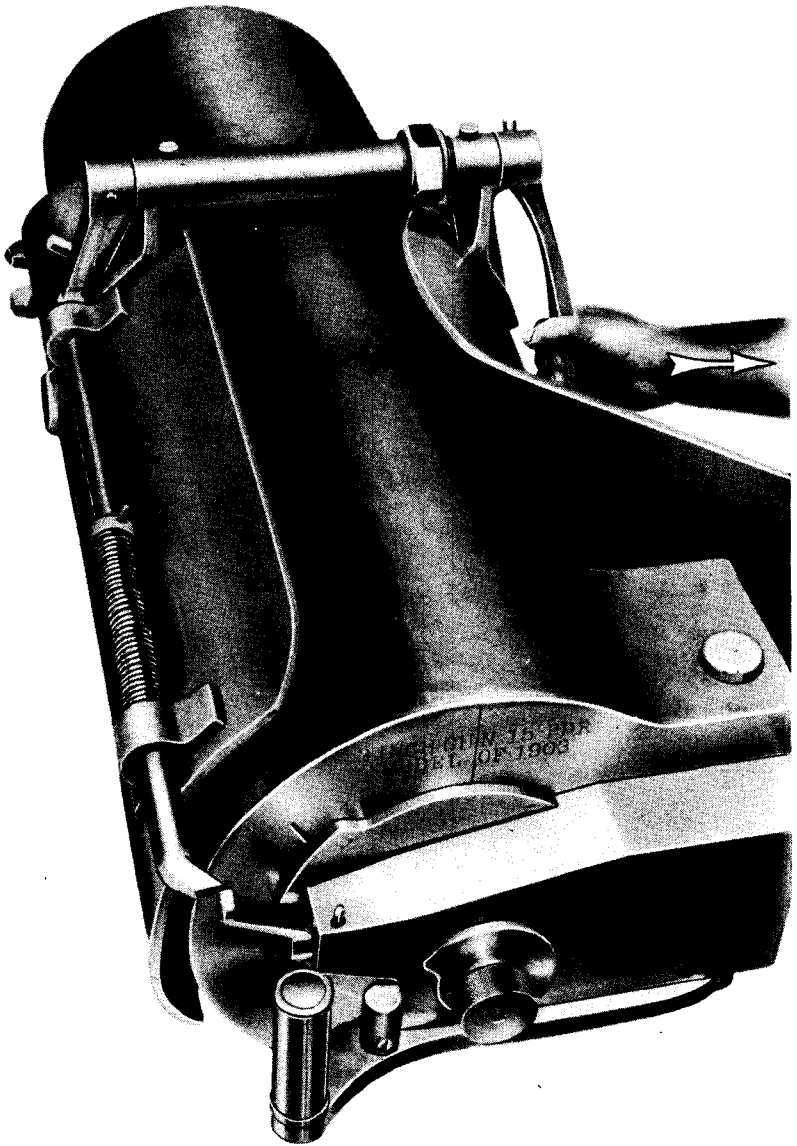

RA PD 50597

Figure 25—Firing Gun by Firing Lever

3-INCH SEACOAST GUN MATERIEL

Section IV

MALFUNCTION AND CORRECTION

	Paragraph
Gun	17
Carriage	18

17. GUN.

Malfunction	Cause	Correction
<p>Fails to fire.</p>	<p>Defective ammunition.</p>	<p>In case of a misfire at least two additional attempts to fire the piece will be made. The breechblock will not be opened until at least ten minutes after the last unsuccessful attempt to fire the piece. The gun will be kept directed in elevation and traverse either on the target or on a safe place in the field of fire.</p>
<p>Seized breechblock.</p>		<p>Notify ordnance maintenance personnel.</p>
<p>Broken and damaged parts of breech mechanism.</p>		<p>Parts may be replaced by the using arm, if the facilities are available; otherwise, notify the ordnance maintenance personnel.</p>
<p>Broken or damaged parts of the firing mechanism.</p>		<p>Parts may be replaced by the using arm, if the facilities are available; otherwise, notify the ordnance maintenance personnel.</p>

MALFUNCTION AND CORRECTION

Malfunction	Cause	Correction
Protrusion of firing pin in breech opening. NOTE: Protrusion of the firing pin has been guarded against on the M1903 gun.	Failure of firing pin to cock.	Disassemble firing mechanism and replace worn or broken parts.

18. CARRIAGE.

Malfunction	Cause	Correction
Failure of gun to return fully into battery.	Weak or broken counterrecoil spring.	Notify ordnance maintenance personnel.
Excessive recoil.	Cylinder not filled to capacity. Excessive clearance in cylinder buffer.	Fill with recoil oil. Notify ordnance maintenance personnel.

3-INCH SEACOAST GUN MATERIEL

Section V

CARE AND PRESERVATION

	Paragraph
General	19
After firing	20
Disassembly and cleaning of breech mechanism	21
Disassembly and cleaning of the firing mechanism	22
Lubrication instructions	23
Preparation for active season	24
Preparation for inactive season	25
Service of the gun and carriage during inactivity	26
Servicing materials	27

19. GENERAL.

a. Routine service of the gun and carriage is described in this section.

b. Keeping all parts of the gun and carriage in good condition is a matter of vital importance. Proper lubrication and care are absolutely necessary to obtain good performance.

c. All parts provided with oilholes should be lubricated at the correct intervals. When carriages are in use for daily drills, a thorough lubrica-

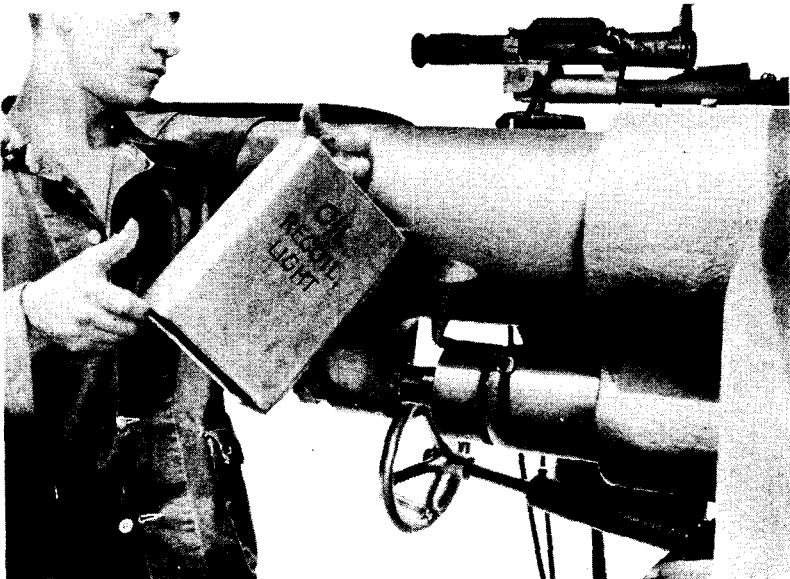

RA PD 35805

Figure 26—Filling Recoil Cylinder M1902 Carriage

CARE AND PRESERVATION

tion twice a week should be sufficient for all but the most severely used parts. The recoil cylinder must be filled with oil before firing is started. To fill the cylinder on the M1902 carriage (fig. 26) remove the plug in the filling hole and bring the gun to depression. To fill the cylinder on the M1903 carriage (fig. 28) remove the plug in the filling hole and bring the gun to elevation. The recoil cylinder should be completely filled with OIL, recoil, light, until the oil comes up to the level of the filling hole. Replace the filling plug and then loosen the drain plug so as to drain off ½ pint of oil. (Fig. 27 shows this operation on the M1902 carriage; fig. 29 for the M1903 carriage.) Then tighten drain plug.

d. When the materiel is not in use, all covers furnished should be in place (fig. 30).

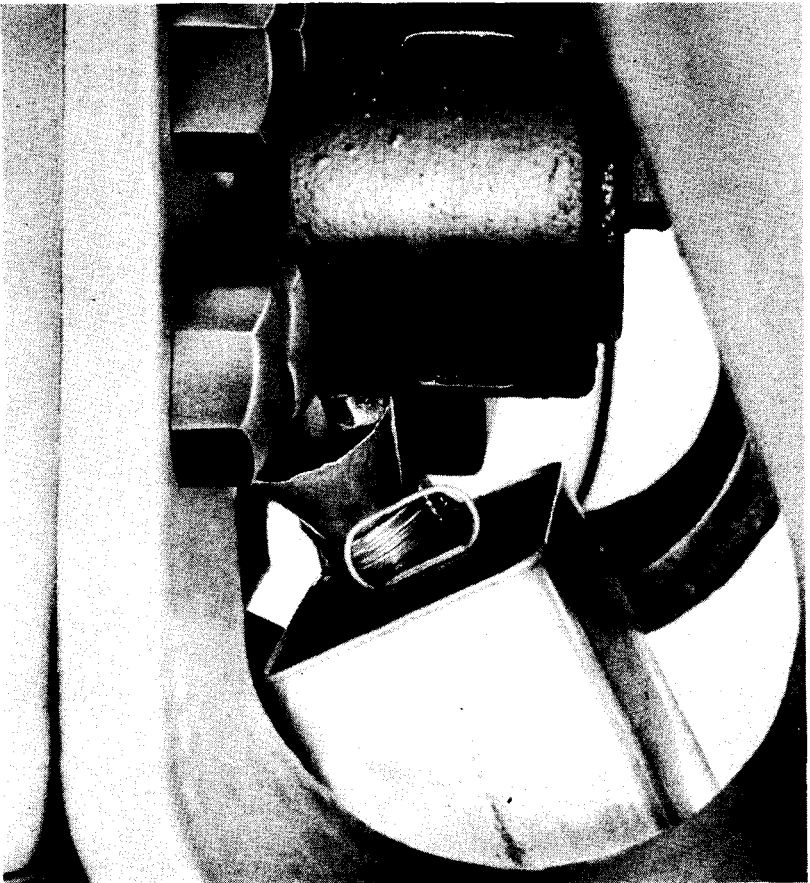

RA PD 35806

Figure 27—Draining Recoil Cylinder M1902 Carriage

3-INCH SEACOAST GUN MATERIEL



RA PD 35845

Figure 28—Filling Recoil Cylinder M1903 Carriage

e. Keep the firing mechanism assembled on the gun when the gun is being manned continually. When it is no longer necessary to man the gun, disassemble the mechanism, see that it is properly cleaned and oiled, then store it in a magazine room at the emplacement.

20. AFTER FIRING.

a. **Bore.** After firing, and while the gun is still warm, the bore should be cleaned. Swab the bore (fig. 31) with a solution of one-half pound of SODA ASH or one pound of sal soda to each gallon of water. This solution should be warm when used. When all powder fouling has been removed, swab the bore with clear water. Then dry the bore, using the bore sponge covered with burlap or cleaning cloths. Oil the bore with OIL, engine, SAE 10 (for temperature below 32 F), or SAE 30 (for temperatures above 32 F).

b. **Breech Mechanism.** The breech mechanism should be disassembled, cleaned, and oiled immediately after firing. This is especially important, as no provision is made for oiling by means of oilers or oil channels.

CARE AND PRESERVATION

c. **Firing Mechanism.** Since the clearances between parts of the firing mechanism are very small, care must be exercised to keep the mechanism well oiled and free from rust and dirt. The mechanism should always be disassembled, cleaned, and oiled immediately after firing.

21. DISASSEMBLY AND CLEANING OF BREECH MECHANISM.

a. Disassembly of the Breech Mechanism for Cleaning.

(1) Grasp the operating lever and open the mechanism (fig. 32).

(2) When the mechanism is open, force the breechblock latch out of its seat in the breechblock flange (fig. 33), revolve the breechblock to the right until it stops, remove the trigger shaft (figs. 34 and 35) and firing mechanism (fig. 36); then pull the breechblock from the hub of the carrier (fig. 37), taking care not to drop it. If the firing case of the firing mechanism is tight, it can be removed by inserting the end of the trigger shaft into the hole in the knurled portion of the case and revolving it to the left.

(3) The breechblock latch can now be easily removed.

(4) Drift out the hinge pin, then take hold of the carrier and operating lever and pull out the hinge pin (figs. 38 and 39).

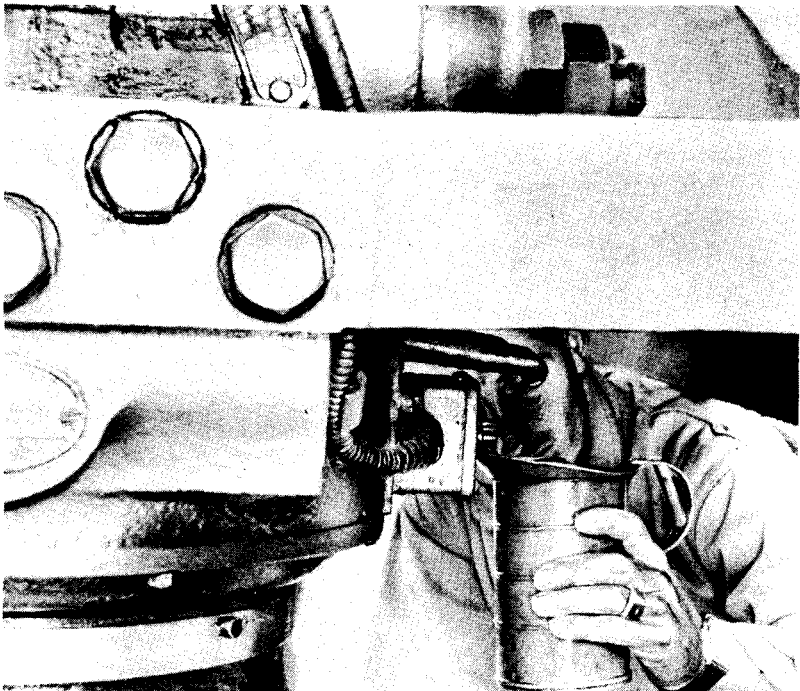

RA PD 35846

Figure 29—Draining Recoil Cylinder M1903 Carriage

3-INCH SEACOAST GUN MATERIEL

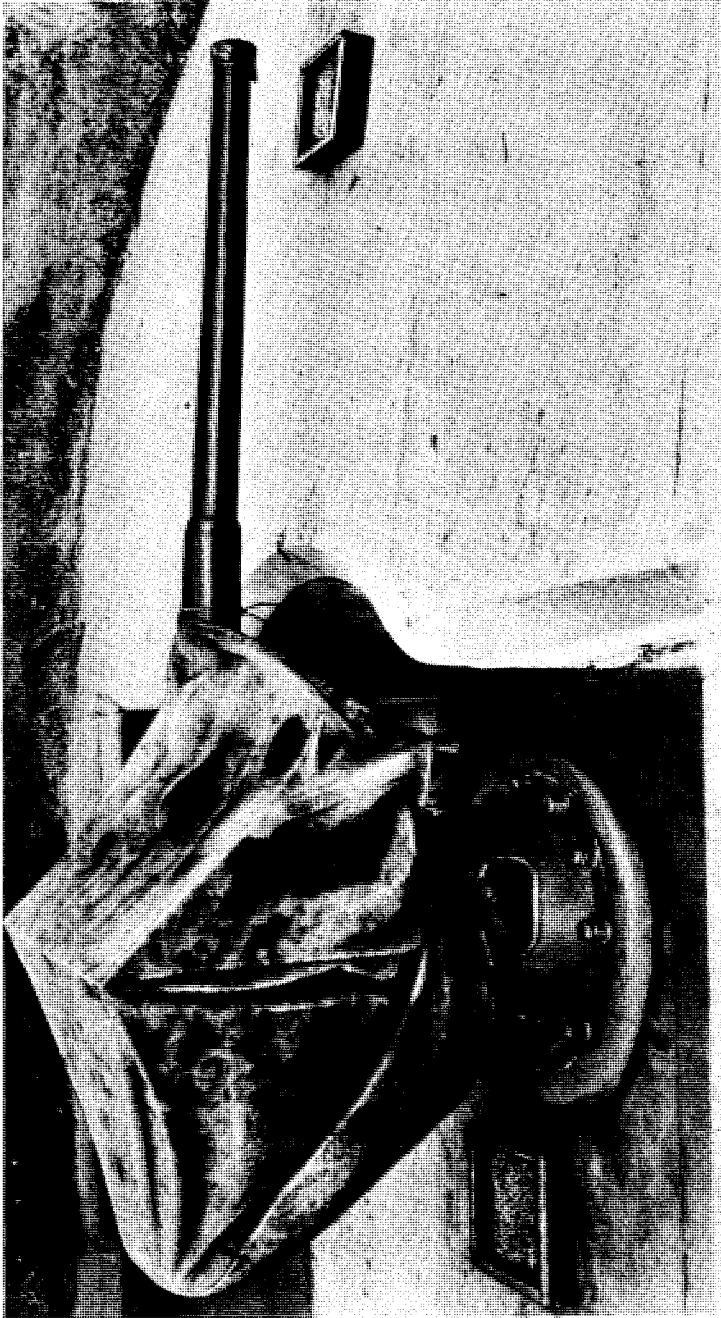

RA PD 35807

Figure 30—Covering Gun

CARE AND PRESERVATION

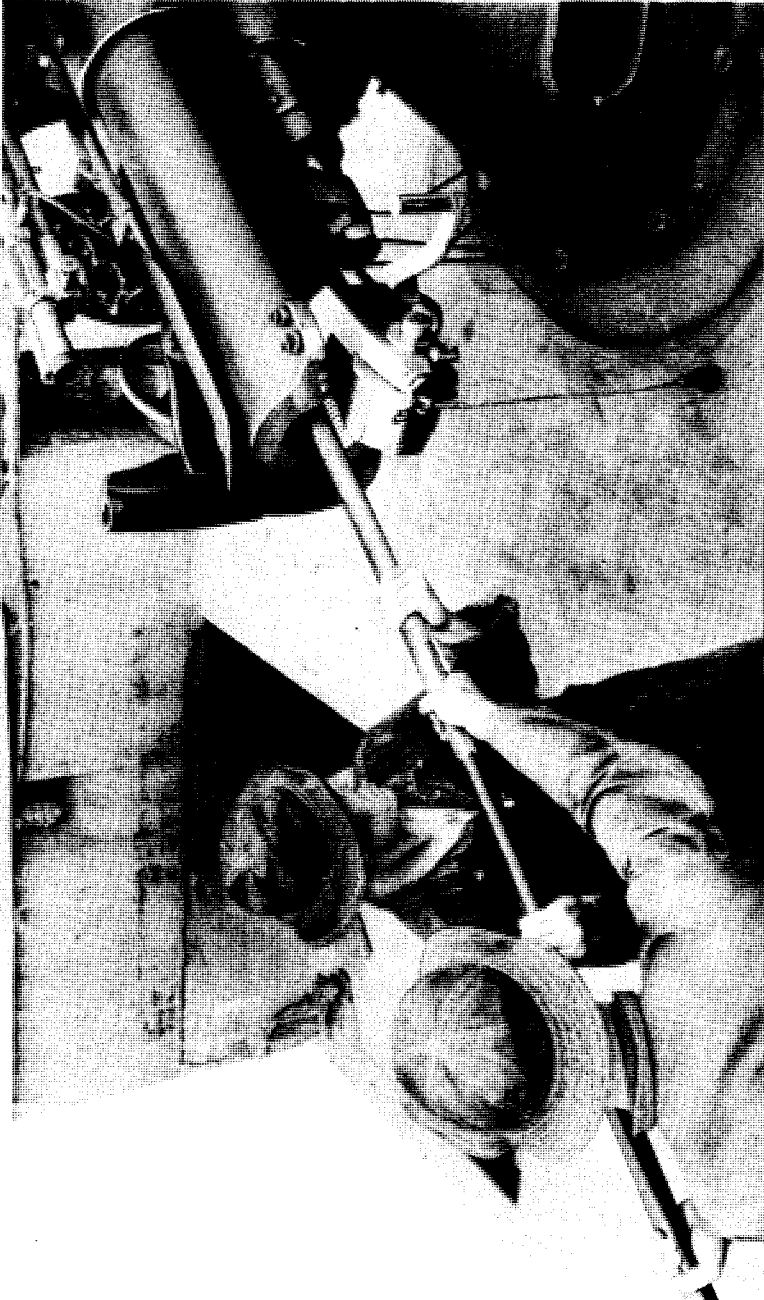

RA PD 35808

Figure 31 — Swabbing Bore of Gun

3-INCH SEACOAST GUN MATERIEL

(5) Remove the operating bar and lever (fig. 40). Then remove carrier (fig. 41). (On the M1903 gun the carrier and operating lever are removed together (fig. 42).

(6) Remove the extractor (fig. 45). (On the M1902M1 gun it is necessary to drift and pull out the extractor hinge pin before the extractor can be removed (figs. 43 and 44).)

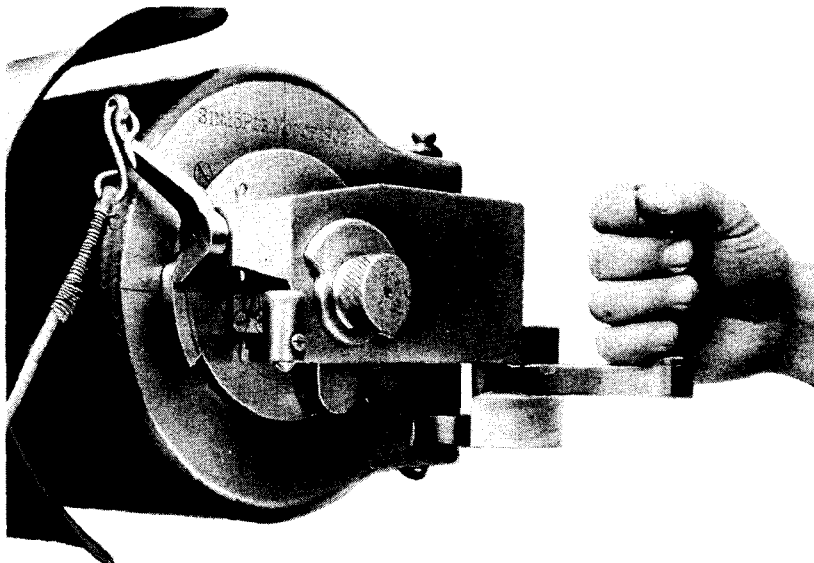

RA PD 35809

Figure 32—Opening Breech

(7) Care must be taken to detect any cutting or abrasions on the threads of the breechblock or breech recess. Scores or bruises on the threads should be reported to ordnance maintenance personnel.

b. Cleaning and Oiling. Clean all bright surfaces with SOLVENT, dry-cleaning. Be sure all traces of powder stains or rust deposits are removed, using CLOTH, crocus, if necessary. Wipe the surfaces dry and remove all particles of grit by using clean rags. Lubricate with a thin film of OIL, engine, SAE 30, above 32 F, SAE 10, below 32 F.

c. Assembly of the Breech Mechanism.

(1) Replace the extractor in its recess and slide the operating bar into its seat.

(2) Replace the breechblock carrier and operating lever and drive in the hinge pin.

(3) Replace the breechblock latch.

(4) Replace the breechblock onto the hub of the carrier.

(5) Replace the firing mechanism.

CARE AND PRESERVATION

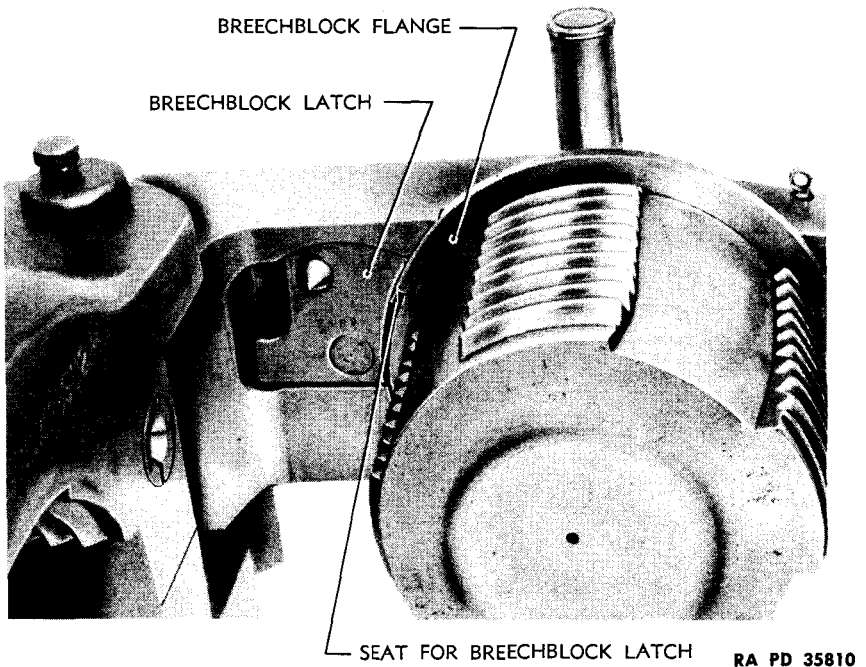

Figure 33—Breechblock Latch Out of Its Seat in Breechblock Flange

22. DISASSEMBLY AND CLEANING OF THE FIRING MECHANISM.

a. Disassembly of the Firing Mechanism for Cleaning.

(1) Take hold of the trigger shaft detent and pull it out (fig. 34). At the same time push the trigger shaft to the left, removing it from its seat (fig. 35).

(2) Take hold of the knurled-headed end of the firing case and revolve it to the left until it stops; then pull it gently to the rear. This will remove the case and the complete firing mechanism from the gun.

(3) Gently press on the front end of the firing pin, forcing it back into the case. This will allow the cocking lever to be taken out.

(4) Grasp the front end of the firing pin and turn it sufficiently to disengage the sear, after which it can be removed from the case.

(5) Press the end of the firing-spring follower and revolve it sufficiently to disengage the projecting pin on the follower from the firing pin. The follower and spring can then be disassembled.

(6) Turning the firing case in the hand, allow the sear and spring to fall out of its seat.

3-INCH SEACOAST GUN MATERIEL

b. **Cleaning and Oiling.** Clean all bright surfaces with SOLVENT, dry-cleaning. Be sure all traces of powder stains or rust deposits are removed, using CLOTH, crocus, if necessary. Wipe the surfaces dry and remove all particles of grit by using clean rags. Lubricate with a thin film of engine oil. At low temperatures clean thoroughly with SOLVENT, dry-cleaning, and apply sparingly OIL, lubricating, for aircraft instruments and machine guns.

23. LUBRICATION INSTRUCTIONS.

a. **General.** Excessive wear can be prevented and the life of the gun and carriage increased by keeping the materiel clean and well lubricated. Apply sufficient lubrication but avoid wasteful practices. Excessive lubrication will result in dust accumulations on some moving parts and cause wear and malfunctioning. Particular attention should be given to the lubrication of sliding surfaces of the breech mechanism and to other bearing surfaces that do not contain oilholes or plugs. Parts should be manipulated while the lubricant is being applied so as to distribute

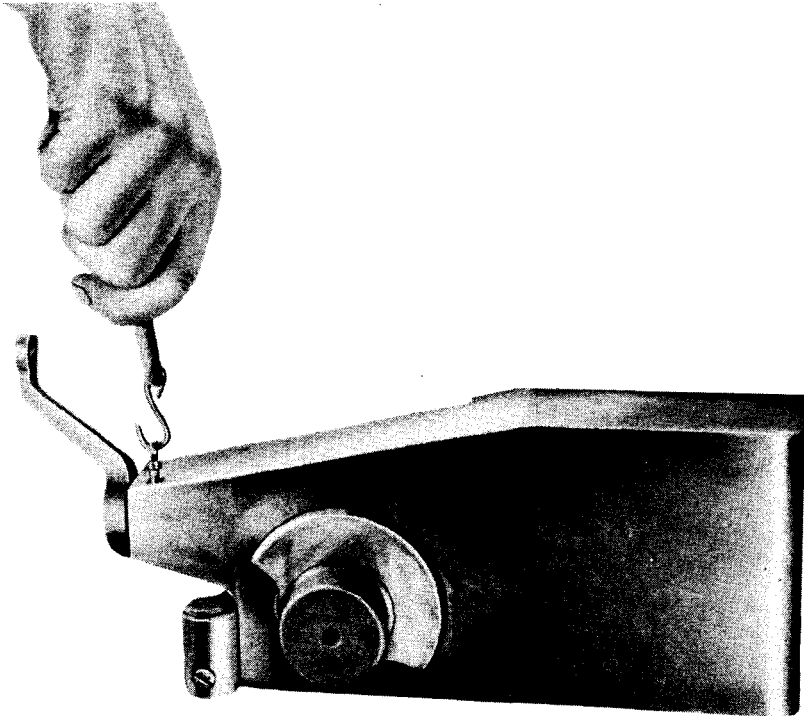

RA PD 35849

Figure 34—Removing Detent

CARE AND PRESERVATION

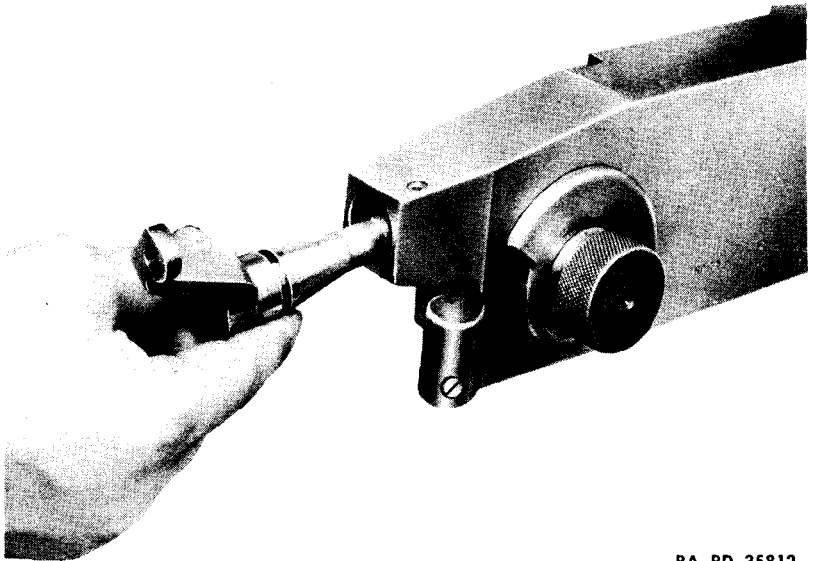

RA PD 35812

Figure 35—Removing Trigger Shaft

the lubricant over the bearing surfaces. Only the lubricants prescribed in the lubrication charts (figs. 46, 47, and 48) will be used.

b. Identification of Lubrication Points. Lubrication fittings are painted red for ease in locating.

c. Oilholes. All oilholes must be cleaned out frequently to keep them free from sand and grit. They should be kept closed with the screw plug provided, except during oiling. Before oiling at any hole, carefully wipe off any dirt or grit near the opening that might be carried down into the bearing by the oil.

d. Gear Cases. When cleaning oil compartments, care must be taken to insure complete removal of oil residue or sediment. Dirt or foreign matter should not be allowed to drop into any of the lubricating compartments.

e. Receptacles. The lubricants will be kept in receptacles plainly labeled with their contents. These should always be kept closed to prevent contamination by water, dirt, etc.

f. Reports. If lubrication instructions are closely followed and proper lubricants used, and satisfactory results are not obtained, a report will be made to the ordnance officer responsible for the maintenance of the materiel.

g. Records. A complete record of lubrication servicing will be kept for the materiel.

3-INCH SEACOAST GUN MATERIEL

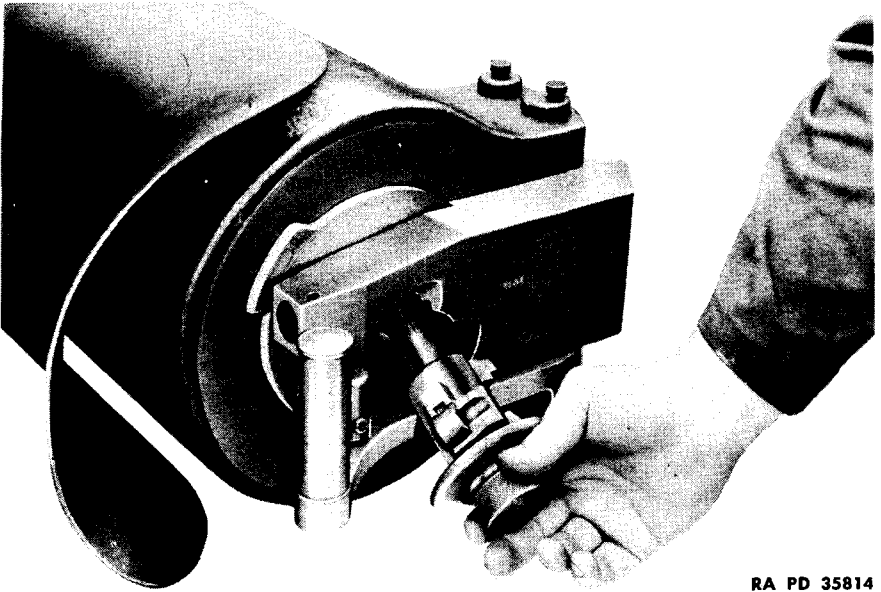

RA PD 35814

Figure 36—Removing Firing Mechanism

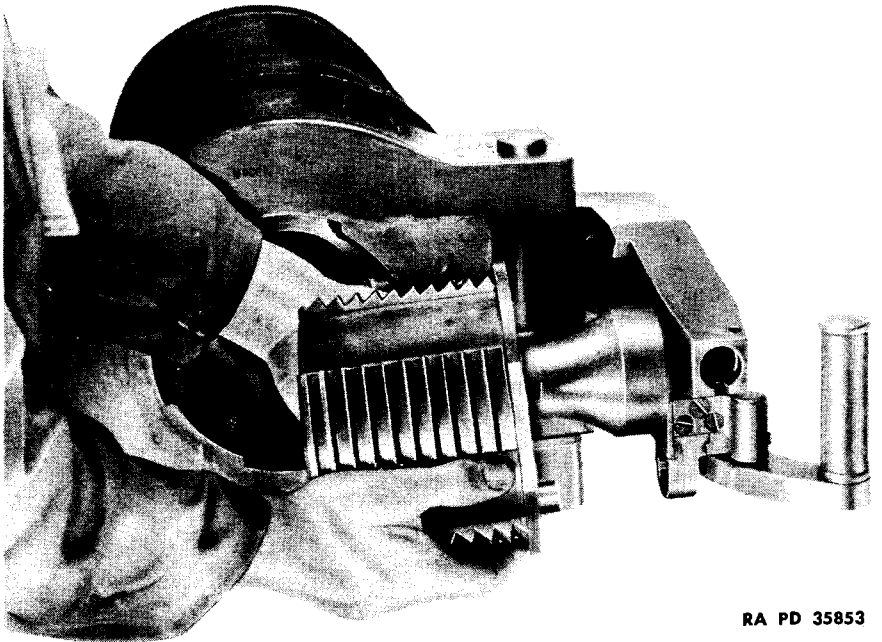

RA PD 35853

Figure 37—Removing Breechblock from Carrier

CARE AND PRESERVATION

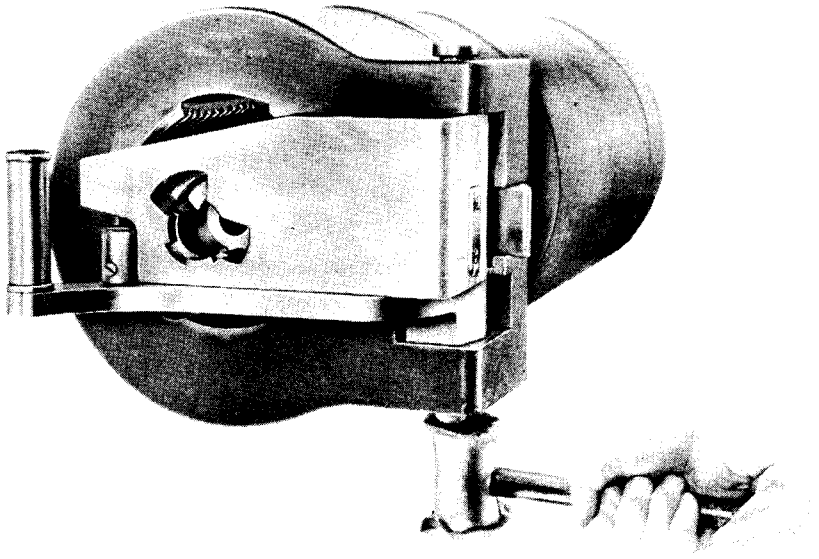

RA PD 35854

Figure 38—Drifting Out Hinge Pin

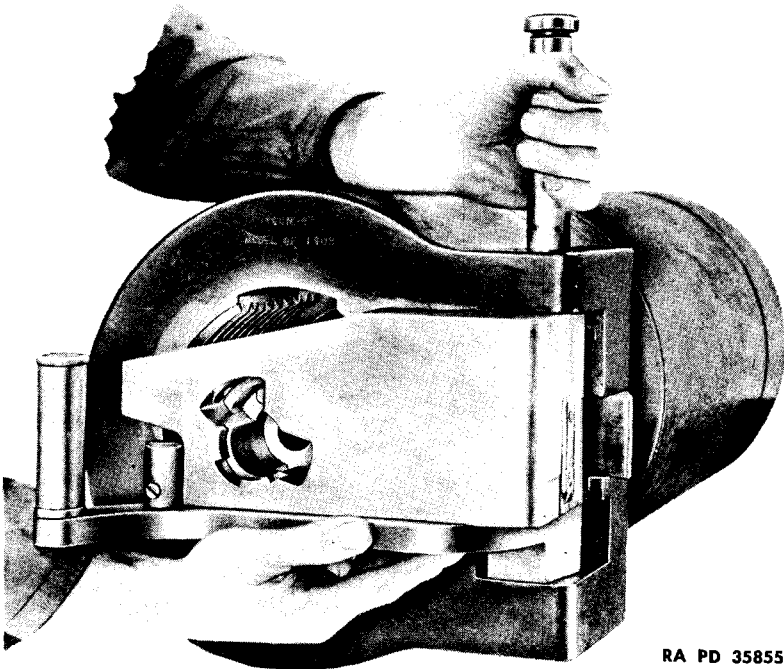

RA PD 35855

Figure 39—Pulling Out Hinge Pin

3-INCH SEACOAST GUN MATERIEL

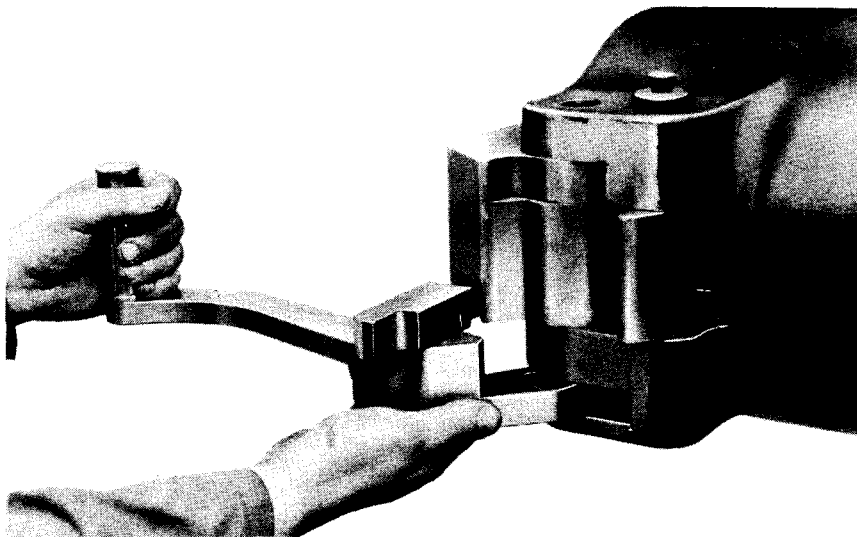

RA PD 35818

**Figure 40—Removing Operating Bar and Operating Lever
M1902MI Gun**

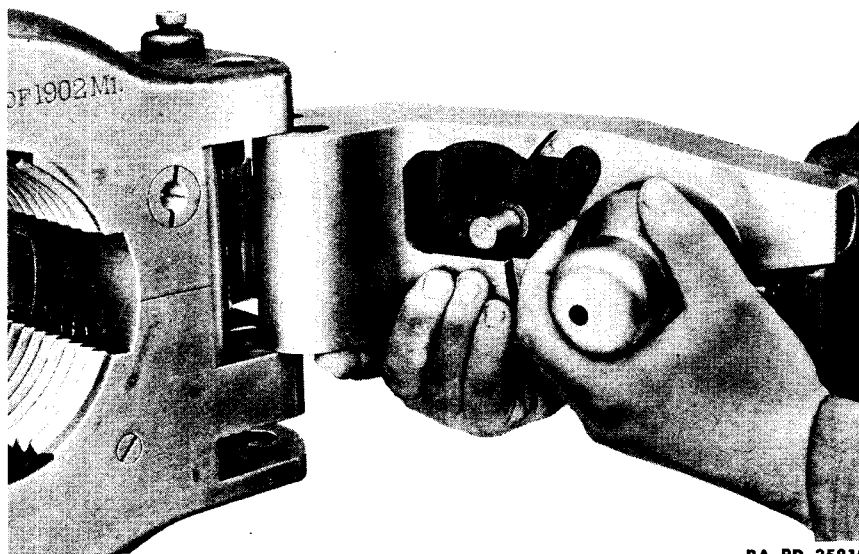

RA PD 35819

Figure 41—Removing Carrier M1902MI Gun

CARE AND PRESERVATION

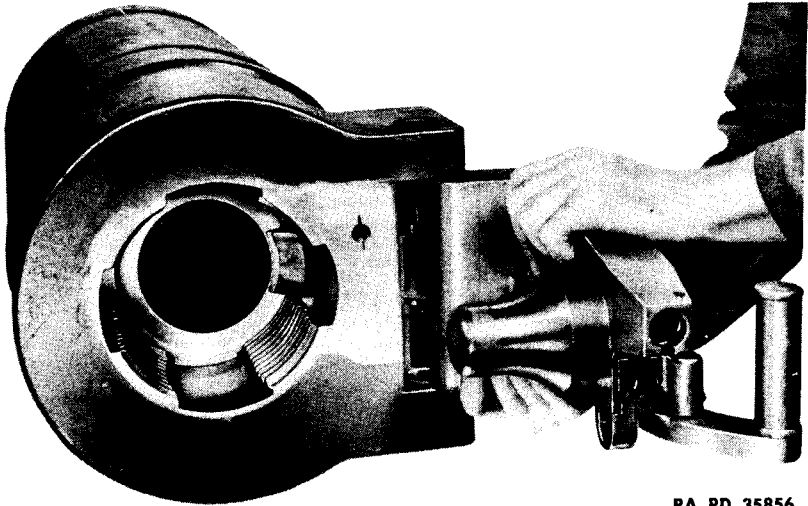

RA PD 35856

Figure 42—Removing Carrier and Operating Lever M1903 Gun

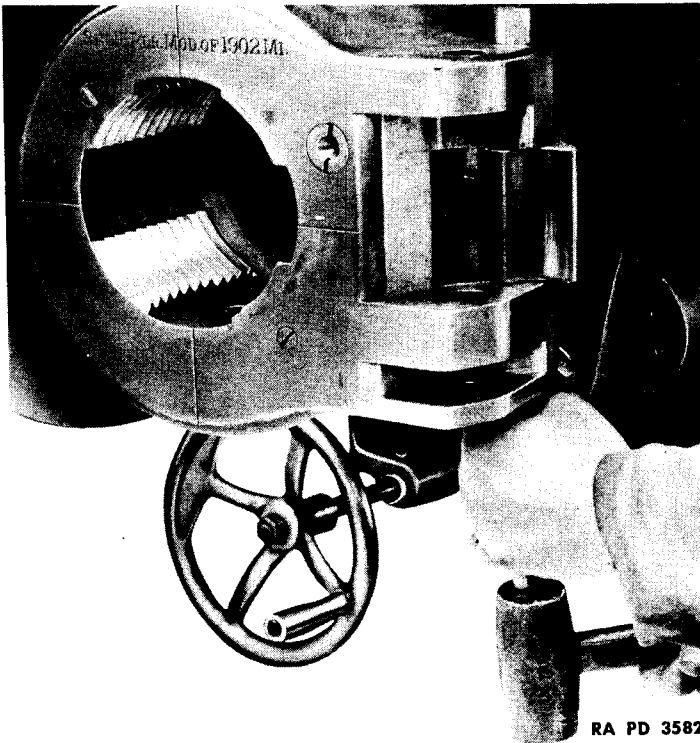

RA PD 35820

Figure 43—Drifting Out Extractor Hinge Pin M1902M1 Gun

3-INCH SEACOAST GUN MATERIEL

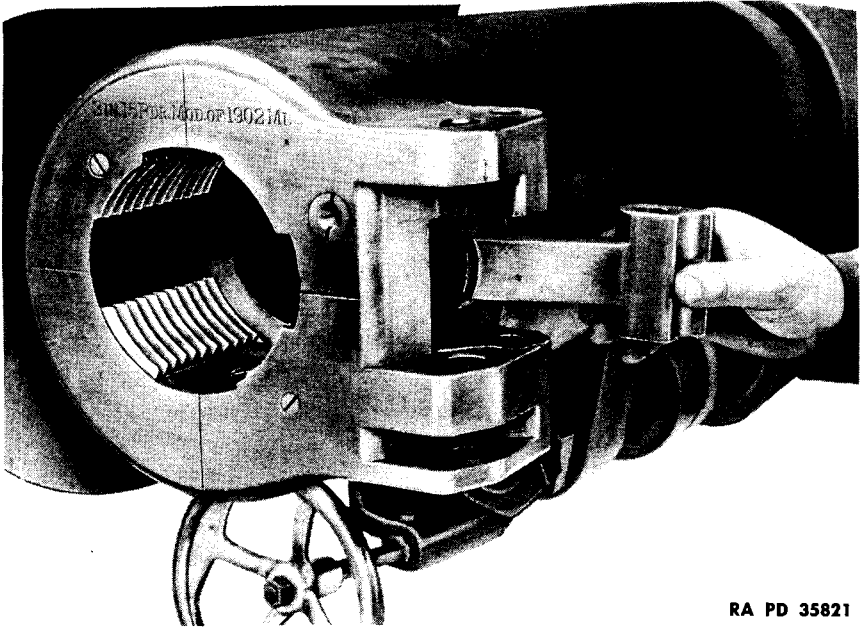

RA PD 35821

Figure 44—Removing Extractor M1902MI Gun

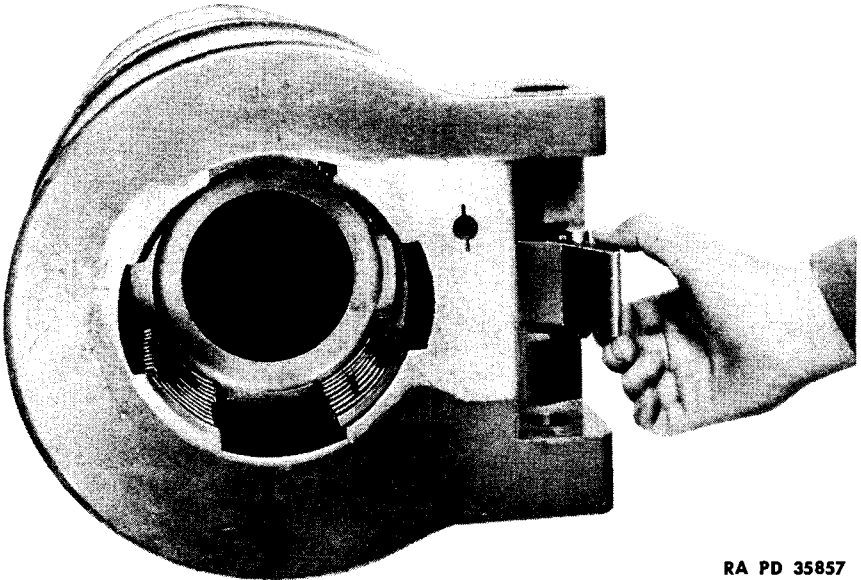

RA PD 35857

Figure 45—Removing Extractor M1903 Gun

CARE AND PRESERVATION

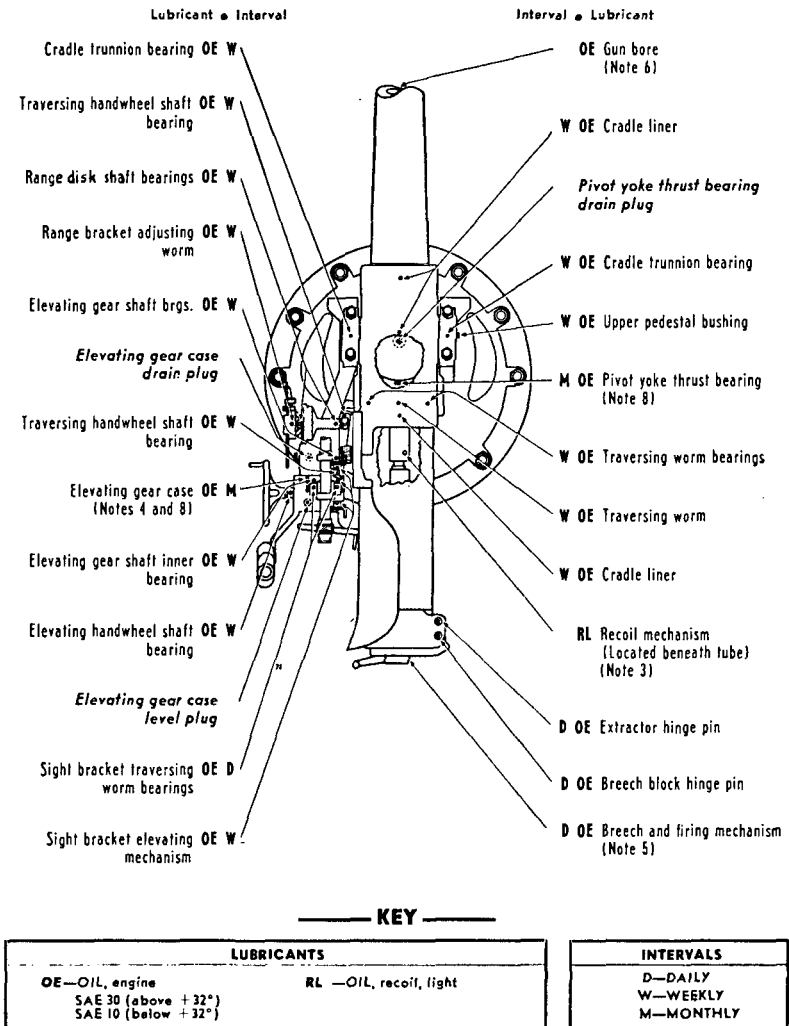

RA PD 50752

Figure 46—Lubrication Chart M1902MI Gun and M1902 Carriage
57

3-INCH SEACOAST GUN MATERIEL

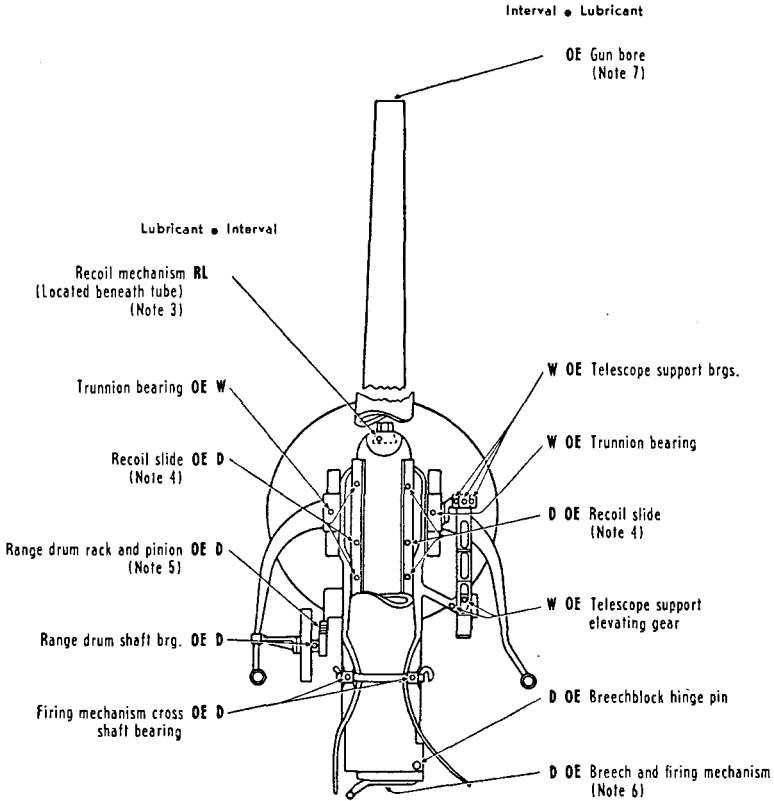

NOTE—See page 4 for lubrication of CARRIAGE

KEY

LUBRICANTS	
OE—OIL, engine SAE 30 (above +32°) SAE 10 (below +32°)	RL —OIL, recoil, light

INTERVALS
D—DAILY W—WEEKLY

RA PD 50753

Figure 47—Lubrication Chart M1903 Gun and Cradle

CARE AND PRESERVATION**NOTES****Additional Lubrication and Service Instructions on Individual Units and Parts**

COLD WEATHER: For Lubrication and Service below 10 degrees, refer to OFSB 6-5.

1. **OIL SCREW PLUGS.** Clean plug and surrounding surface, then remove and apply lubricant. Lubricate following heavy rains.
2. **INTERVALS** indicated are for normal service. For extreme conditions of heat, water, dust, etc., lubricate more frequently.
3. **RECOIL FLUID.** For instructions on quantity and application of recoil fluid, refer to War Department Fluid Guide No. 59 and OFSB 6-7.
4. **ELEVATING GEAR CASE.** Monthly, check level, add oil, if necessary. Every 6 months, drain and refill. Fill case to level plug opening with OIL, engine, seasonal grade.
5. **BREECH AND FIRING MECHANISM.** Daily, and before and after firing, clean and oil all moving parts and exposed metal surfaces with OIL, engine, seasonal grade.
6. **GUN BORE.** After firing, clean and coat with OIL, engine, seasonal grade. Daily, inspect and oil if necessary.
7. **ELEVATING AND RANGE DISK RACKS AND PINIONS, TRAVERSING RACK AND TRAVERSING BEVEL PINIONS.** Daily, clean and apply OIL, engine, seasonal grade. The teeth of exposed racks and pinions require little lubrication but, as a protection against rust, they will be kept covered with a thin coat of OIL, engine, seasonal grade. Dust and grit will adhere to this oily film. Consequently the teeth of these units will be thoroughly cleaned and fresh oil applied before traversing or elevating the gun. If considerable dust is present when gun is operated, the oil will be removed from the teeth and they will be allowed to remain dry until action is over. If the surfaces are dry, there is less wear than when coated with a lubricant contaminated with grit.
8. **POINTS TO BE LUBRICATED BY ORDNANCE MAINTENANCE PERSONNEL AT TIME OF ORDNANCE INSPECTION.** Elevating gear case, pivot yoke thrust bearing.

3-INCH SEACOAST GUN MATERIEL

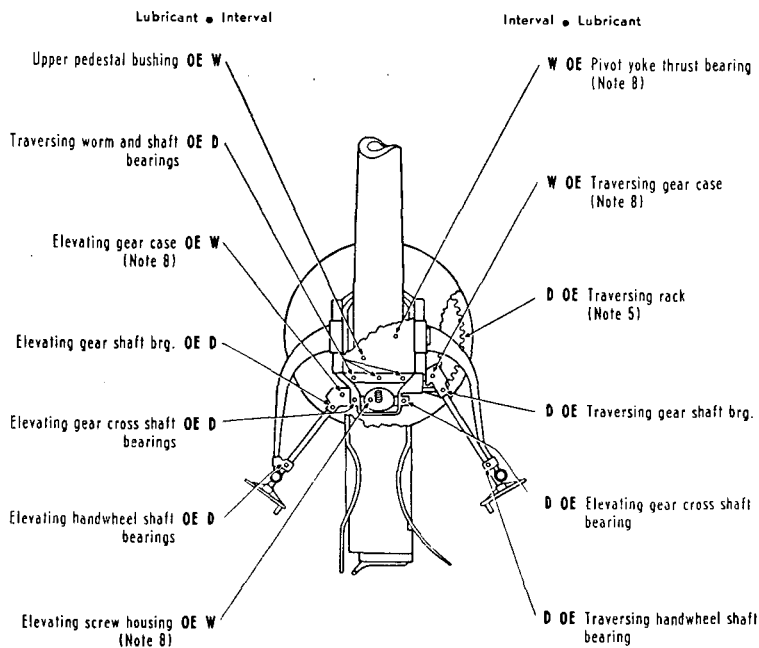

— KEY —

LUBRICANTS
OE—OIL, engine
SAE 30 (above + 32°)
SAE 10 (below + 32°)

INTERVALS
D—DAILY
W—WEEKLY

RA PD 50754

Figure 48—Lubrication Chart M1903 Carriage

CARE AND PRESERVATION**NOTES****Additional Lubrication and Service Instructions on Individual Units and Parts**

COLD WEATHER: For Lubrication and Service below 10 degrees, refer to OFSB 6-5.

1. **OIL SCREW PLUGS.** Clean plug and surrounding surface, then remove and apply lubricant. Lubricate following heavy rains.
2. **INTERVALS** indicated are for normal service. For extreme conditions of heat, water, dust, etc., lubricate more frequently.
3. **RECOIL FLUID.** For instructions on quantity and application of recoil fluid, refer to War Department Fluid Guide No. 59 and OFSB 6-7.
4. **RECOIL SLIDES.** Daily and before firing, clean and oil exposed metal surfaces. Keep surfaces covered with thin film of OIL, engine, seasonal grade.
5. **TRAVERSING RACK, RANGE DRUM RACK AND PINION.** Daily, clean and apply OIL, engine, seasonal grade. The teeth of the traversing rack and range drum rack and pinion require little lubrication but, as a protection against rust, they will be kept covered with a thin coat of OIL, engine, seasonal grade. Dust and grit will adhere to this oily film. Consequently the teeth of these units will be thoroughly cleaned and fresh oil applied before traversing or elevating the gun. If considerable dust is present when gun is operated, the oil will be removed from the teeth and they will be allowed to remain dry until action is over. If the surfaces are dry, there is less wear than when coated with a lubricant contaminated with grit.
6. **BREECH AND FIRING MECHANISM.** Daily, and before and after firing, clean and oil all moving parts and exposed metal surfaces with OIL, engine, seasonal grade. To insure easy breech operation and to avoid misfiring in cold weather, clean with SOLVENT, dry-cleaning, dry and lubricate with OIL, lubricating, for aircraft instruments and machine guns. To clean firing mechanism, remove and operate pin in SOLVENT, dry-cleaning.
7. **GUN BORE.** After firing, clean and coat with OIL, engine, seasonal grade. Daily, inspect and oil if necessary.
8. **POINTS TO BE LUBRICATED BY ORDNANCE MAINTENANCE PERSONNEL AT TIME OF ORDNANCE INSPECTION.** Traversing and elevating gear cases, elevating screw housing, pivot yoke thrust bearing (par. 3).

3-INCH SEACOAST GUN MATERIEL

24. PREPARATION FOR ACTIVE SEASON.

- a. At the beginning of the active season all exposed finished surfaces must be thoroughly cleaned and lubricated. Careful inspection of finished and unfinished surfaces must be made and rust and marred paint removed. Cleaning and preparation of surfaces for repainting or touching up is covered in Chapter 6.
- b. Remove the pivot thrust bearing, clean, lubricate, and replace.
- c. Clean and lubricate the pintle bearings and lower the yoke.
- d. Empty the recoil cylinder, wash out by filling with SOLVENT, dry-cleaning, and exercising the mechanism, and refill with OIL, recoil, light.
- e. Elevate the gun and traverse the carriage throughout the entire movements by hand.
- f. Lubricate all parts that can be reached without disassembly.
- g. Inspect and remove all rust, reslush as required, and put on all covers.
- h. Leave the carriage about 30 degrees from its former position in traverse.

25. PREPARATION FOR INACTIVE SEASON.

- a. **Breech and Firing Mechanisms.** At the beginning of the inactive season or when the weapon is not to be used for a considerable time, the breech mechanism should be disassembled, coated with COMPOUND, rust preventive, light, and stored at the emplacement. The firing mechanism should not be allowed to remain in the breechblock during storage, but should be disassembled, coated with COMPOUND, rust preventive, light. The parts should then be laid on a board at the emplacement for periodic inspection and covered with a canvas.
- b. **Bore.** The bore should also be cleaned with SOLVENT, dry-cleaning, and coated with COMPOUND, rust preventive, light.
- c. **Exterior Finished Surfaces.** All other exterior finished metal surfaces should be coated with COMPOUND, rust preventive, heavy. This coating can be applied as in painting, using sash-tool No. 6, except that in cold weather it should be applied by stippling; *i.e.*, light tapping, with the brush held perpendicular to the surface to be covered.
- d. **Painted Surfaces.** All painted surfaces should be carefully examined. Particular care should be given to painting and touching up operations to obtain the maximum protection against rust, erosion, and weather. The protective coating of paint prevents the materiel from deterioration.
- e. **Bearings.** Lubricate with OIL, lubricating, preservative, medium, sufficiently to flush out the engine oil. Relubricate monthly.

CARE AND PRESERVATION

f. **Elevating Gear Case and Pivot Yoke Thrust Bearing.** Under supervision of ordnance maintenance personnel drain, remove covers or cases, and clean with SOLVENT, dry-cleaning. Reassemble, flood case with OIL, lubricating, preservative, medium. Check oil level monthly and add oil, if necessary.

g. **Open Gears, Screws, Worms and Racks.** Remove any covers, clean thoroughly with SOLVENT, dry-cleaning, and coat thickly and completely with COMPOUND, rust preventive, light.

h. **Recoil Slides.** Under supervision of ordnance maintenance personnel withdraw the gun from the cradle, clean and coat the recoil slides with COMPOUND, rust preventive, heavy, and replace the gun.

i. **Sighting Parts.** Oil heavily the sight brackets elevating mechanism, range bracket adjusting worm, and similar fire control and sighting parts with OIL, lubricating, preservative, medium. Inspect monthly and reoil, if necessary.

26. SERVICE OF GUN AND CARRIAGE DURING INACTIVITY.

a. At intervals not to exceed six days, all coated surfaces must be examined, cleaned and recoated where the preservative has come off. Immediately after rain or snow, all surfaces should be carefully examined and when necessary recoated.

b. At regular intervals of 30 days or less the recoil cylinders should be checked and filled, if necessary, and the carriages should be maneuvered throughout their complete range of traverse and elevation. The carriage should be left in traverse about 30 degrees from its former position to prevent the thrust bearing from rusting at bearing surfaces.

c. All parts of the carriage must be kept clean at all times. Rust should not be allowed to accumulate on piston rods or bearing surfaces, and this requires particular attention. The use of sandpaper or CLOTH, emery, for the purpose of removing rust, etc. is forbidden. The rust may be softened, if necessary, with SOLVENT, dry-cleaning, and removed with CLOTH, crocus.

27. SERVICING MATERIALS.

The following materials are commonly required for servicing the gun:

a. **Lubricants.** See lubrication charts (figs. 46, 47 and 48).

b. **Cleaning Materials.**

CLOTH, crocus

PAPER, flint, No. 00

PAPER, flint, No. 1/2

PAPER, flint, No. 1

PAPER, flint, No. 2

3-INCH SEACOAST GUN MATERIEL

- PATCHES, cut (canton flannel)
- POLISH, metal, paste
- REMOVER, paint and varnish
- SODA, caustic (lye), for cleaning purposes
- SOLVENT, dry-cleaning
- SPONGE
- WASTE, cotton, colored
- WASTE, cotton, white

(1) PAPER, flint, is issued for use on woodwork such as rammer handles and armament chest. Do not use it on metal surfaces.

(2) SODA, caustic (lye), is issued for cleaning purposes.

(3) SPONGES are used for washing and cleaning materiel. Natural sponges may be replaced by cellulose sponges in sizes No. 4 (approx. dimensions 1¼ x 3⅛ x 4⅝ in.); No. 6 (approx. dimensions 1⅝ x 3½ x 5¼ in.); No. 8 (approx. dimensions 2 x 3⅞ x 6¼ in.); No. 10 (approx. dimensions 2½ x 4⅝ x 6½ in.). Cellulose sponges must not be wrung. Squeezing is the proper method.

(4) WASTE, cotton, colored, is used for general cleaning purposes on the exteriors of ordnance materiel. It is used as calking for cracks from which it is desired to exclude dust and dirt. White waste is used for general cleaning purposes on finished surfaces of ordnance materiel. If no WASTE, cotton, white, is on hand, an equivalent amount of clean wiping cloths may be used.

c. **Preserving Materials.** During both active and inactive seasons the lubrication oils serve as preservatives as well as lubricants; therefore, thorough lubrication is doubly important. The following preservatives are used in addition to the lubricants for protecting finished surfaces exposed to the weather during active periods and for protecting all unpainted surfaces during inactivity:

- COMPOUND, rust preventive, light
- COMPOUND, rust preventive, heavy
- OIL, lubricating, preservative, medium

d. **Recoil Oil.** OIL, recoil, light, will be used in the recoil cylinders.

Section VI

INSPECTION AND ADJUSTMENT

	Paragraph
General	28
Gun	29
Breech mechanism	30
Firing mechanism	31
Traversing mechanism	32
Elevating mechanism	33
Recoil and counterrecoil mechanism	34
Mount	35
Electrical equipment	36
Sight	37

28. GENERAL.

a. Inspection has as its purpose the detection of conditions, which cause improper performance. Such conditions may be caused by:

(1) Mechanical deficiencies resulting from ordinary wear and breakage.

(2) Faulty or careless operation.

(3) Improper care (servicing and lubrication). Inspection should always be accompanied by corrective measures to remedy any deficiencies found. When properly carried out, inspection and necessary corrective maintenance will insure the maximum reliability and performance of the materiel. The following inspection should be made at regular intervals not to exceed 30 days during both active and inactive seasons.

b. Before making a detailed inspection, the gun and carriage should be inspected (figs. 49 and 50) in general for evidences of faulty operation, care, and maintenance. Any unusual conditions which might result in improper operation or damage to the materiel must be immediately remedied. Untidy appearance and evidences of rust or deterioration must be corrected. Missing or broken apparatus must be replaced.

29. GUN.

Inspection

Note condition of bore. Look for copper deposits and rust.
Note lubrication of bore.

Adjustment

Remove any rust or copper deposits. Clean and slush. Wipe dry and lubricate.

3-INCH SEACOAST GUN MATERIEL

30. BREECH MECHANISM.

Inspection

Note smoothness of operation of the breech mechanism in opening and closing.

Examine the breechblock and breech recess for burs, indentations on the threads, rust, pitting, and other evidences of erosion.

Adjustment

If the mechanism binds or does not operate smoothly, disassemble, clean, examine the parts for wear or breakage, and replace unserviceable parts. Lubricate the mechanism and reassemble. If it is still difficult to operate, notify ordnance maintenance personnel.

If not possible to smooth or clean with CLOTH, crocus, notify ordnance maintenance personnel. Do not use any other abrasive.

31. FIRING MECHANISM.

Inspection

Note the action of the firing mechanism by pulling on lanyard when breech is open. A pull on the trigger shaft operates the cocking lever which compresses the firing pin spring. A shoulder on the cocking lever trips a spring actuated sear releasing the firing pin to firing position. The firing spring will then force the firing pin back to the cocked position. The firing pin should snap into both firing and cocked positions. The firing pin should not protrude beyond the front face of the breechblock when breech is open. NOTE: The firing pin cannot protrude on the M1903 gun.

Adjustment

Repair or replace parts of the firing mechanism which may be worn or broken.

INSPECTION AND ADJUSTMENT

32. TRAVERSING MECHANISM.

Inspection

Operate the traversing mechanism to determine smoothness of operation and whether there is any backlash or play in the mechanism.

Inspect for defective or broken parts.

Examine for proper lubrication.

Adjustment

Lubricate. If this fails, notify ordnance maintenance personnel.

Notify ordnance maintenance personnel.

Lubricate, if necessary.

33. ELEVATING MECHANISM.

Inspection

Operate the elevating mechanism to determine smoothness of operation and whether there is any backlash or play in the mechanism.

Inspect for defective or broken parts.

Examine for proper lubrication.

Adjustment

Lubricate. If this fails, notify ordnance maintenance personnel.

Notify ordnance maintenance personnel.

Lubricate, if necessary.

34. RECOIL AND COUNTERRECOIL MECHANISM.

Inspection

Check recoil cylinder for proper amount of oil (par. 19).

Exercise the piece, using a block and tackle to determine amount of recoil, which should be approximately nine inches (pars. 15b and 16b).

The gun should not jump or slam into battery. The gun should ease into battery smoothly against the action of the buffer mechanism.

Note whether or not the piston rod is properly secured to the lug on the gun. The nut and check nut should be tight.

Adjustment

If necessary, refill. Remove $\frac{1}{2}$ pint after oil reaches level of filling hole.

If necessary refill, should the piece recoil in excess of nine inches. If cylinder is full, notify ordnance maintenance personnel.

If necessary, refill cylinder. If this does not remedy the condition, notify ordnance maintenance personnel.

Tighten, if necessary.

3-INCH SEACOAST GUN MATERIEL

Inspection

Inspect for any leakage of oil around the cylinder head, where the head is screwed into the cylinder (par. 8).

Inspect for leakage at stuffing box or follower.

Adjustment

Notify ordnance maintenance personnel.

Tighten follower. Care should be taken not to tighten too much, as this produces excessive friction on the rod. One man using the wrench provided is able to tighten the follower sufficiently. Do not use a pipe for additional leverage on the wrench as this will shear the threads. If this does not stop leakage, the box needs repacking. Notify ordnance maintenance personnel.

35. MOUNT.

Inspection

Inspect pivot yoke thrust bearing for lubrication.

Examine trunnion bearings for lubrication and cleanliness.

Examine foundation bolts for tightness.

Adjustment

Lubricate, if necessary.

Clean and lubricate, if necessary.

Tighten, if necessary.

36. ELECTRICAL EQUIPMENT.

Inspection

Note whether exposed cables are frayed or broken.

Test lighting circuit for functioning by turning on the switch.

Adjustment

Repair frayed insulation by taping. Replace damaged conductors.

Replace lamps, if necessary. If circuit fails to function, notify ordnance maintenance personnel.

37. SIGHT.

Inspection

The sight elevating mechanism should operate smoothly.

Adjustment

Lubricate, if necessary. If this fails, notify ordnance maintenance personnel.

INSPECTION AND ADJUSTMENT

Inspection

On the M1902 carriage, grasp the range disk and rotate it against the pressure of the spiral spring. Release disk and allow it to rotate back to its normal position. This procedure will indicate either backlash or a broken spring (par. 11).

On the M1903 carriage, grasp the range drum and follow the same procedure as indicated above for the range disk.

Adjustment

Notify ordnance maintenance personnel.

3-INCH SEACOAST GUN MATERIEL

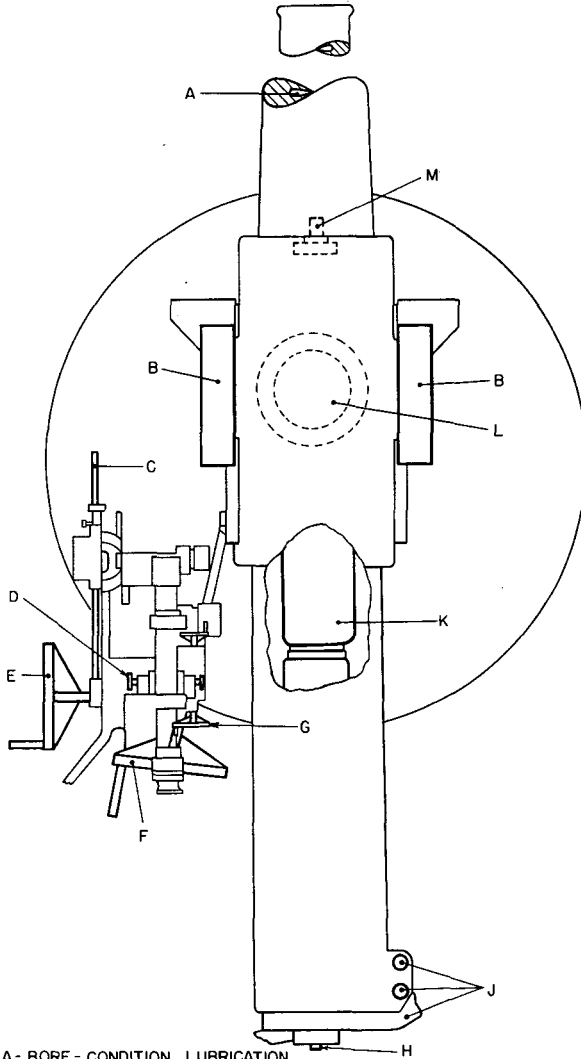

- A - BORE - CONDITION, LUBRICATION
- B - TRUNNION BEARINGS - LUBRICATION
- C - RANGE DISK - FUNCTION
- D - DEFLECTION SCALE - ADJUSTMENT
- E - ELEVATING MECHANISM - FUNCTION, CONDITION, LUBRICATION
- F - TRAVERSING MECHANISM - FUNCTION, CONDITION, LUBRICATION
- G - SIGHT ELEVATION MECHANISM - FUNCTION, LUBRICATION
- H - FIRING MECHANISM - FUNCTION
- J - BREECH MECHANISM - FUNCTION, CONDITION
- K - RECOIL CYLINDERS - FILLED, FUNCTION
- L - PIVOT YOKE THRUST BEARING - LUBRICATION
- M - TRAVERSING LOCKING DEVICE - FUNCTION

RA PD 35824

Figure 49—Inspection Chart M1902MI Gun and M1902 Carriage

INSPECTION AND ADJUSTMENT

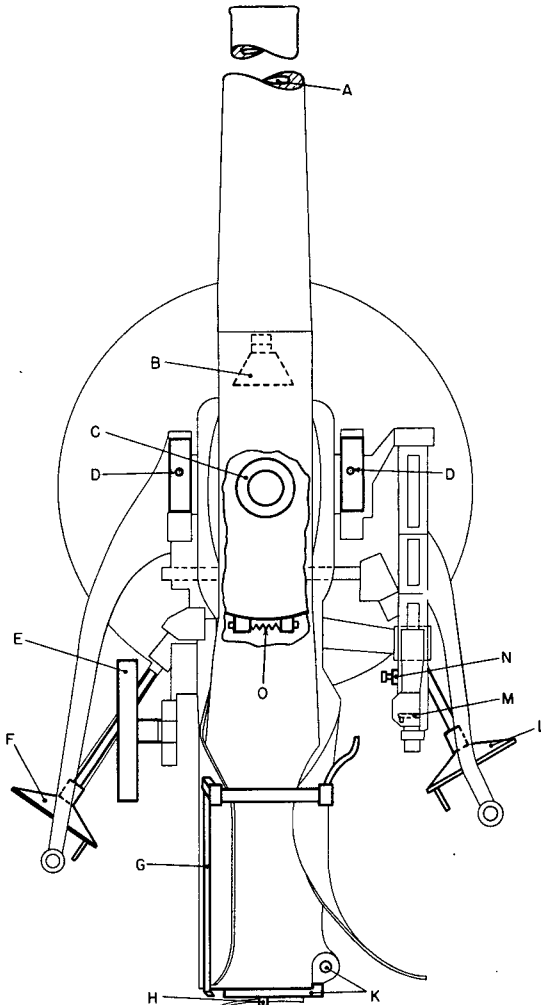

- A - BORE - CONDITION, LUBRICATION
 - B - RECOIL CYLINDER - FILLED, FUNCTION
 - C - PIVOT YOKE THRUST BEARING - LUBRICATION
 - D - TRUNNION BEARINGS - LUBRICATION
 - E - RANGE DRUM - FUNCTION
 - F - ELEVATION MECHANISM - FUNCTION, LUBRICATION, CONDITION
 - G - FIRING LEVER - FUNCTION, LUBRICATION
 - H - FIRING MECHANISM - FRICTION
 - K - BREACH MECHANISM - FUNCTION, CONDITION
 - L - TRAVERSING MECHANISM - FUNCTION, LUBRICATION, CONDITION
 - M - SIGHT ELEVATING MECHANISM - FUNCTION, LUBRICATION
 - N - DEFLECTION SCALE - ADJUSTMENT
 - O - FRICTION BAND ADJUSTMENT BOLT - ADJUSTMENT
- RA PD 35859

Figure 50—Inspection Chart M1903 Gun and Carriage

3-INCH SEACOAST GUN MATERIEL

Section VII

REPAIR

Paragraph

General 38

38. GENERAL.

a. Wear, breakage, or damage from enemy fire make necessary the occasional disassembly and repair of various parts of the gun and mount. This comes under two headings; that which can be performed by the battery personnel with the equipment furnished, and that which must be performed by trained ordnance personnel. In all cases where the nature of the repair, modification, or adjustment is beyond the scope of facilities of the unit, the responsible ordnance service should be informed in order that trained personnel with suitable tools and equipment may be provided, or proper instructions issued.

b. Disassembly, assembly, and such repairs as may be handled by the using arms personnel will be undertaken only under the supervision of an officer or the chief mechanic.

c. Repairs, other than those outlined under "Malfunction and Correction," "Care and Preservation," or "Inspection and Adjustment," should not be performed by the battery personnel, as the repairs would be beyond the scope or facilities of the unit.

Chapter 3

AMMUNITION

	Paragraph
General	39
Nomenclature	40
Firing tables	41
Classification	42
Identification	43
Care, handling, and preservation	44
Authorized rounds	45
Preparation for firing	46
Ammunition for the GUN, 3-inch (15-pdr.), M1902MI	47
Ammunition for the GUN, 3-inch (15-pdr.), M1903	48
Fuzes	49
Packing	50
Subcaliber ammunition	51
Field report of accidents	52

39. GENERAL.

a. Ammunition for the GUN, 3-inch (15-pdr.) M1902MI, and for the GUN, 3-inch (15-pdr.), M1903, is issued in the form of fixed complete rounds. The term "fixed" signifies that the propelling charge is fixed (not adjustable) and that the round is loaded into the gun as a unit. The propelling charge is assembled loosely in the cartridge case which is crimped rigidly to the projectile. A complete round of ammunition comprises all of the components necessary to fire one round.

40. NOMENCLATURE.

Standard nomenclature is used herein in all references to specific items of issue. Its use for all purposes of record is mandatory.

41. FIRING TABLES.

For applicable firing tables, see paragraph 78.

42. CLASSIFICATION.

Dependent upon the type of projectile, ammunition for these guns is classified as high explosive, target practice, blank, or drill. The high explosive projectile contains a high explosive filler. The target practice

3-INCH SEACOAST GUN MATERIEL

projectile contains no explosive; it consists of either a solid projectile (designated shot) or a heavy-walled projectile with an empty base cavity. The blank ammunition has a black powder (low explosive) charge in the cartridge case and no projectile. The drill ammunition consists of completely inert cartridge which simulates the service ammunition.

43. IDENTIFICATION.

a. General. Ammunition is completely identified by means of the painting and marking (includes ammunition lot number). See figures 51 to 55 and the following subparagraphs.

b. Mark or Model. To identify a particular design, a model designation is assigned at the time the design is classified as an adopted type. This model designation becomes an essential part of the standard nomenclature and is included in the marking on the item. The present system of model designation consists of the letter M followed by an Arabic numeral. Modifications are indicated by adding the letter A and appropriate Arabic numerals. Thus M42A1 indicates the first modification of an item for which the original designation was M42. Prior to July 1, 1925, it was the practice to assign mark numbers. The word "mark", abbreviated "Mk.", was followed by a Roman numeral, for example: SHELL, H.E., Mk. I. The first modification of a model was indicated by the addition of MI to the mark number, the second by MII, etc.

c. Ammunition Lot Number. A lot number is assigned all ammunition at the time of manufacture. It is stamped or marked on every loaded complete round and on all packing containers. It is required for all purposes of record, including reports on condition, functioning, and accidents in which the ammunition is involved. To provide for the most uniform functioning, all of the rounds in any one lot of fixed ammunition are assembled so as to consist of:

- Projectiles of one lot number (one type and one weight zone).
- Fuzes of one lot number.
- Primers of one lot number.
- Propellant powder of one lot number.

To obtain the greatest accuracy in any firing, successive rounds should be from the same ammunition lot whenever practicable.

d. Painting and Marking.

(1) **PAINTING.** All projectiles are painted to prevent rust and corrosion and by the color to provide a ready means of identification as to type. The projectiles of the ammunition described herein are painted as follows:

AMMUNITION

- High explosive Yellow: marking in black.
- Practice Black: marking in white. (Projectile is inert.)
- Drill or dummy (inert) Black: marking in white.

Note that the above color scheme is not wholly in agreement with the basic color scheme, described in TM 9-1900, practice projectiles being generally painted blue.

(2) **MARKING.** For purposes of identification, the following is marked on the components of each round of fixed ammunition:

(a) *On the Projectile.*

- Caliber and type of cannon in which fired.
- Kind of filler, for example, "TNT," "EXP. D.," etc.
- Mark or model of projectile.
- Weight zone marking when required.
- "WITH TRACER" (on practice shot which has tracer).
- Lot number. Because this is ordinarily not required after the complete round has been assembled, it is stenciled below the rotating band, in which position it is covered by the neck of the cartridge case.

(b) *On the Cartridge Case.* Recently changes have been made in the marking on the cartridge cases. The present practice, which applies to ammunition of new manufacture as well as currently renovated ammunition, is shown compared with the older practice in Table I below:

TABLE I. Marking on the cartridge case. Markings are in black unless otherwise indicated.

Place	Old marking	Present marking
On the body of the cartridge case	<p>"FLASHLESS" when propelling charge is of flashless (FNH) powder.</p> <p>Initials of powder manufacturer, symbol of powder, and lot number.</p> <p>Caliber and type of cannon in which fired.</p> <p>Muzzle velocity in feet per second. On normal charge rounds, the muzzle velocity is enclosed in a black rectangle.</p>	None

3-INCH SEACOAST GUN MATERIEL

Place	Old marking	Present marking
On the body of the cartridge case	Ammunition lot number. (In older lots, stamped in the metal.) "FLASHLESS" when propelling charge is of flashless (FNH) powder. Model of projectile. One diametral stripe indicates normal charge. Caliber, type, and model of cannon in which fired (stamped in the metal). Cartridge case lot number and initials of cartridge case manufacturer (stamped in the metal).	Ammunition lot number and initials of loader. None Model of projectile. (Omitted) Caliber and model of cartridge case (stamped in the metal). Cartridge case lot number, initials of cartridge case manufacturer, and year of manufacture (stamped in the metal).

(c) *On the Fuze.* (Stamped on the body.)

- Type and model of fuze.
- Manufacturer's initials.
- Year of manufacture.
- Lot number.

e. Weight Zone Markings. Because it is not practicable to manufacture projectiles within the narrow weight limits required for the desired accuracy of fire, projectiles are grouped into weight zones in order that the appropriate ballistic corrections indicated by firing tables may be applied. The weight zone of the projectile is indicated thereon by means of squares, in the same color as the marking, with a prick punch in the center of each square; one, two, three, or more being used, dependent upon the weight of the projectile. For these guns, one square indicates "normal" weight. On some shell of older manufacture, crosses are used in place of squares.

44. CARE, HANDLING, AND PRESERVATION.

a. Ammunition is packed to withstand conditions ordinarily encountered in the field. Complete rounds are packed in individual moisture-resistant fiber containers and then in a wooden packing box. Since explosives are adversely affected by moisture and high temperature, the following precautions should be observed:

AMMUNITION

(1) Moisture-resistant seals should not be broken until ammunition is to be used.

(2) Ammunition, particularly fuzes, should be protected from high temperatures, including the direct rays of the sun. More uniform firing is obtained if the rounds are at the same temperature.

b. No attempt will be made to disassemble any fuze.

c. Ammunition must be handled with appropriate care at all times. The explosive elements in primers and fuzes are particularly sensitive to undue shock and high temperature.

d. The complete round should be free of foreign matter—sand, mud, grease, etc.—before loading into the gun. If it gets wet or dirty, it should be wiped off at once.

e. Protective or safety devices must not be removed from fuzes until just before use.

f. Rounds prepared for firing but not fired will be restored to their original condition and packings and appropriately marked. Such rounds will be used first in subsequent firings in order that stocks of opened packings may be kept at a minimum.

g. Duds will not be handled. Because their fuzes are armed, duds are extremely dangerous, will not be moved or turned but will be destroyed in place in accordance with TM 9-1900.

45. AUTHORIZED ROUNDS.

a. General.

(1) **SERVICE AND PRACTICE ROUNDS.** The service round and the practice round authorized for the GUN, 3-inch (15-pdr.), M1902MI, and for the GUN, 3-inch (15-pdr.), M1903 consists of a projectile and a cartridge case crimped, thereto, which contains a primer and a propelling charge of nonhygroscopic smokeless powder. In general, the projectiles of the service and the practice rounds have ogival heads of 7 caliber radius. Current standard projectiles for these guns have gilding metal rotating bands, 1 inch wide, which have 2 cannelures or grooves; those of older manufacture have gilding metal or copper rotating bands approximately $\frac{1}{2}$ inch wide with no cannelures. All projectiles for these guns have square bases; that is, the surface to the rear of the rotating band is cylindrical. The projectile of the service round is made of steel. It is fitted with a fuze and contains a high explosive bursting charge; the base is fitted with a base cover to prevent the hot gasses from the propelling charge from coming in contact with the bursting charge in the projectile through possible flaws in the base. The projectile of the practice round is made of steel or cast iron, either an empty shell or a solid shot, and is completely inert (contains no explosive). The base of the

3-INCH SEACOAST GUN MATERIEL

solid practice shot may be fitted with a tracer. The service and the practice rounds are fitted with the PRIMER, M28A1, which contains 300 grains of black powder.

(2) **BLANK AMMUNITION.** The blank round has no projectile; it consists of the primer and a black powder charge contained in a brass cartridge case which is closed with a felt wad and a pulpboard closing cup. The primer used in blank rounds, M1B1A1, contains 100 grains of black powder.

(3) **DRILL AMMUNITION.** The drill (dummy) round is a cast bronze cartridge which has approximately the same shape as the complete service round. It consists of a body, a removable base, and a removable dummy fuze or a plug riveted to the body. The round is completely inert.

b. Tables. The ammunition authorized for use in the GUN, 3-inch (15-pdr.), M1902MI, is listed in Table I; the ammunition authorized for use in the GUN, 3-inch (15-pdr.), M1903, is listed in Table II. These guns are not chambered alike; hence the ammunition listed in Table I will not fit in the cartridge chamber of the M1903 gun, and the ammunition listed in Table II will not fit in the cartridge chamber of M1902MI gun. Although the ammunition for these two guns is similar in appearance, there are differences in design, as described in paragraphs 47 and 48, adequate to permit exact identification of the rounds. It will be noted that the nomenclature completely identifies the rounds that are listed in the following tables.

TABLE I
Ammunition for the Gun, 3-Inch (15-Pdr.), M1902MI

Nomenclature	Fuze		Approximate weight of projectiles as fired (pounds)
	Type and Model	Action	
Service Ammunition			
SHELL, fixed, H.E., *M42A1, w/FUZE, P.D., M48, 3-in. (15-pdr.) gun, M1902MI	P.D.*	S.Q.* and delay	12.89
SHELL, fixed, H.E.,* M42, w/FUZE, P.D., M48, 3-in. (15-pdr.) gun, M1902MI	P.D.*	S.Q.* and delay	12.81
SHELL, fixed, H.E.,* M1915, 3-in. (15-pdr.) gun, M1902MI ¹	B.D.*	nondelay	15.00

¹ Earlier types w/FUZE, B.D., Mk. IX.

*B.D.—Base detonating. H.E.—High explosive. P.D.—Point detonating. S.Q.—Superquick.

AMMUNITION

TABLE I (Continued)

Ammunition for the Gun, 3-Inch (15-Pdr.), M1902MI

Nomenclature	Fuze		Approximate weight of projectiles as fired (pounds)
	Type and Model	Action	
Target Practice Ammunition			
PROJECTILE, fixed, target practice, Mk. VIIA1, 3-in. (15-pdr.) gun, M1902MI	none	15.00
PROJECTILE, fixed, target practice, Mk. VII, 3-in. (15-pdr.) gun, M1902MI	none	15.00
SHOT, fixed, target practice, 3-in. (15-pdr.) gun, M1902MI	none	15.00
Blank Ammunition			
AMMUNITION, blank, 3-in. (15-pdr.) gun, M1902MI, and 3-in. AA guns, M1918 (all models), M1 and M3
Drill Ammunition			
CARTRIDGE, drill, M4A1, w/FUZE, dummy, 21-sec., M42A1, 3-in. AA guns, M1918 (all models), M1, and M3, or 3-in. (15-pdr.) gun, M1902MI	Dummy M42A1	21-sec.
CARTRIDGE, drill, M4, w/FUZE, dummy, 21-sec., M42A1, 3-in. AA guns, M1918 (all models), M1, and M3, or 3-in. (15-pdr.) gun, M1902MI	Dummy M42A1	21-sec.
CARTRIDGE, drill, M4A1, w/FUZE, dummy, 21-sec., M42A1, 3-in. AA guns, M1918 (all models), M1, and M3, or 3-in. (15-pdr.) gun, M1902MI	Dummy M42A1	21-sec.
CARTRIDGE, drill, 3-in. (15-pdr.) gun, M1902MI
Subcaliber Ammunition			
See paragraphs 51 and 63

3-INCH SEACOAST GUN MATERIEL

TABLE II
Ammunition for the Gun, 3-Inch (15-Pdr.), M1903

Nomenclature	Fuze		Approximate weight of projectiles as fired (pounds)
	Type and Model	Action	
Service Ammunition			
SHELL, fixed, H.E.,* M42A1, w/FUZE, P.D., M48, 3-in. (15-pdr.) gun, M1903	P.D.* M48	S.Q.* and delay	12.89
SHELL, fixed, H.E.,* M42, w/FUZE, P.D., M48, 3-in. (15-pdr.) gun, M1903	P.D.* M48	S.Q.* and delay	12.81
SHELL, fixed, H.E.,* M1915, 3-in. (15-pdr.) gun, M1903 ¹	B.D.* Mk.V	nondelay	15.00
SHELL, fixed, H.E.,* Mk. I, 3-in. (15-pdr.) gun, M1903 ²	Comb. 21-sec., M1907M	impact or time	15.00
Target Practice Ammunition			
PROJECTILE, fixed, target practice, Mk. VIIA1, 3-in. (15-pdr.) gun, M1903	none	15.00
PROJECTILE, fixed, target practice, Mk. VII, 3-in. (15-pdr.) gun, M1903	none	15.00
SHOT, fixed, target practice, 3-in. (15-pdr.) gun, M1903 ³	none	15.00
Blank Ammunition			
AMMUNITION, blank, 3-in. (15-pdr.) gun, M1903, and 3-in. AA guns, M1917 (all models), M1925MI, M2 and M4
Drill Ammunition			
CARTRIDGE, drill, M3A1, w/FUZE, dummy, 21-sec., M42A1, 3-in. AA guns, M1917 (all models), M1925MI, M2, and M4, 3-in. (15-pdr.) gun, M1903	21-sec. Dummy M42A1

¹ Earlier types w/FUZE, B.D., Mk. IX.

² Formerly listed as SHELL, fixed, H.E., Mk. I, 3-in. AA guns, M1917, M1917MI, M1917A1, M1917MIA1 and fitted with FUZE, type "S" or FUZE, time, 21-sec., AA, Mk. III.

³ Short-point type.

* B.D.—Base detonating. H.E.—High explosive. P.D.—Point detonating. S.Q.—Superquick.

AMMUNITION

TABLE II (Continued)

Ammunition for the Gun, 3-Inch (15-Pdr.), M1903

Nomenclature	Fuze		Approximate weight of projectiles as fired (pounds)
	Type and Model	Action	
Drill Ammunition (Continued)			
CARTRIDGE, drill, M3, w/FUZE, dummy, 21-sec., M42A1, 3-in. AA guns, M1917 (all models), M1925MI, M2, and M4, or 3-in. (15-pdr.) gun, M1903	21-sec. Dummy M42A1		
CARTRIDGE, drill, 3-in. (15-pdr.) gun, M1903			
Subcaliber Ammunition			
See paragraphs 51 and 63			

46. PREPARATION FOR FIRING.

The ammunition authorized for the GUN, 3-inch (15-pdr.), M1902MI, listed in Table I, and the ammunition authorized for the GUN, 3-inch (15-pdr.), M1903, listed in Table II, is shipped as fixed, complete rounds. Each round is ready for firing after removing the packing material and setting the fuze as required. In the case of the high explosive shell when delay action is required, it is necessary to set the fuze DELAY because the fuze is set SUPERQUICK as shipped (par. 49). In the case of projectiles fitted with time fuzes, it is necessary to set the fuze either for percussion action or the required time action (par. 49 c).

47. AMMUNITION FOR THE GUN, 3-INCH (15-PDR.), M1902MI.

a. **General.** The ammunition listed in Table I is designed especially to fit the cartridge chamber of the GUN, 3-inch (15-pdr.), M1902MI. This ammunition is not authorized for any other model of gun. Ammunition for the M1902MI gun can be identified only by the markings on the base (also on the body in earlier types) of the cartridge case showing its caliber and model number, "3-IN. MARK IIM2," and by the length (one in.) of the shoulder of the cartridge case. See also paragraph 47 e and the following subparagraphs.

b. **SHELL, Fixed, H.E., M42A1, w/FUZE, P.D., M48, 3-Inch (15-Pdr.) Gun, M1902MI.** This high explosive round (fig. 51) is intended

3-INCH SEACOAST GUN MATERIEL

for use against submarines, mine sweepers, and invasion craft. It consists of the primer M28A1 and a propelling charge of smokeless powder contained in the brass cartridge case Mk. IIM2 which is crimped rigidly to the shell. The projectile has an ogival radius of 7 calibers. The bursting charge consists of 0.86 pound of trinitrotoluene (TNT). Alternative bursting charges may be 0.77 pound of amatol, or 0.88 pound of trimonite. The rotating band of the projectile is 1 inch wide and has 2 cannellures. A set screw in the ogive holds the BOOSTER, M20 or M20A1, in place. As shipped, this projectile is fitted with the M48 impact type fuze which may be set either superquick or at delay action. The round is 34.05 inches long, weighs 24.93 pounds and contains a propelling charge weighing 4.87 pounds. After removing the packing material and setting the fuze (par. 49 d), the round is ready for firing.

c. SHELL, Fixed, H.E., M42, w/FUZE, P.D., M48, 3-Inch (15-Pdr.) Gun, M1902MI. This high explosive shell is similar to the shell described in paragraph 47 g, except for slight differences in the internal details. This round weighs 24.85 pounds as compared with 24.93 pounds for the M42A1 model.

d. SHELL, Fixed, H.E., M1915, 3-Inch (15-Pdr.) Gun, M1902MI. This high explosive round is designed for use against heavy materiel targets. It consists of the primer M28A1 and a propelling charge of 4.625 pounds of smokeless powder contained in the brass cartridge case Mk. IIM2 which is crimped rigidly to the heavy-walled projectile, which has an ogival radius of 7 calibers. This projectile has a bursting charge of 0.48 pound of explosive D. The base detonating fuze (FUZE, B.D., Mk. V) is fitted to the base of the projectile and is covered by the base cover; hence it is not visible. This round is 34.85 inches long and weighs 26.7 pounds. It is identified by the marking and the narrow ($\frac{1}{2}$ in.) rotating band without cannellures. After removing the packing material, the round is ready for firing.

e. PROJECTILE, Fixed, Target Practice, Mk. VIIA1, 3-Inch (15-Pdr.) Gun, M1902MI. This practice round consists of the primer M28A1 and a propelling charge of 4.75 pounds of smokeless powder contained in the brass cartridge case Mk. IIM2 which is crimped rigidly to the projectile of steel or cast iron. The projectile which has a cavity in the base is inert (contains no explosive) and has no fuze. It has an ogival radius of 7 calibers and is similar in shape and ballistic properties to the fuzed, high explosive service projectile described in paragraph 47 b. The rotating band is 1 inch wide and has two cannellures. The round is 34.27 inches long and weighs 26.74 pounds.

AMMUNITION

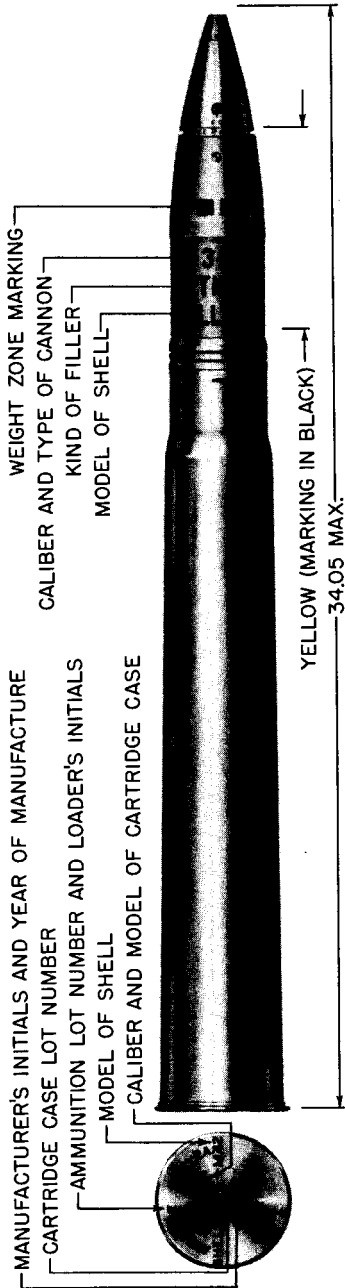

RA PD 4534

Figure 51—Shell, Fixed, H. E., M42, w/Fuze, P. D., M48, 3-inch (15-Pdr.) Gun, M1902MI

3-INCH SEACOAST GUN MATERIEL

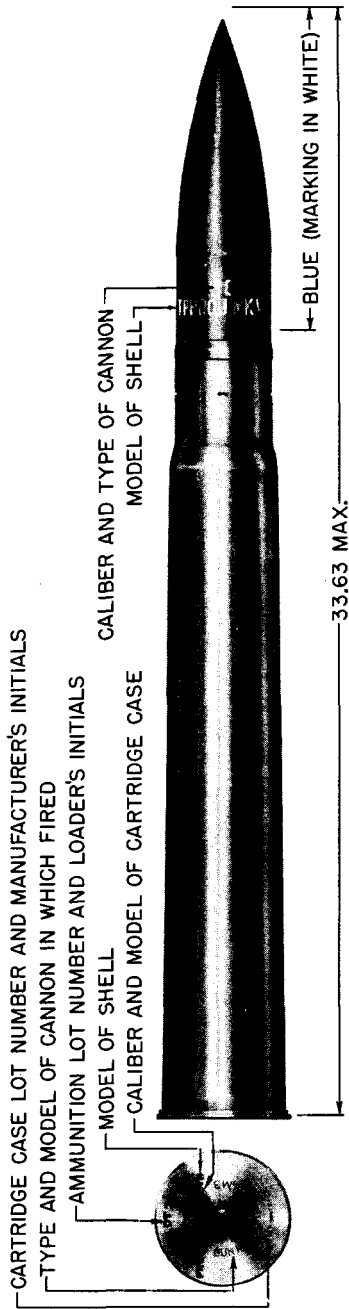

RA PD 4535

Figure 52—Projectile, Fixed, Target Practice, Mk. VII, 3-inch (15-Pdr.) Gun, M1902MI

AMMUNITION

f. PROJECTILE, Target Practice, Mk. VII. 3-Inch (15-Pdr.) Gun, M1902MI. This practice round (fig. 52) is similar to the Mk. VIIA1 practice round described in paragraph 46 e. It has the same type cartridge case (Mk. IIM2), but there are slight differences in the design of the projectile. The projectile of this round, either of cast iron or steel, is solid (has no cavity) and the rotating band is $\frac{1}{2}$ inch wide without cannelures. The round is 34.19 inches (cast iron) or 33.52 inches (steel) long, and weighs 26.83 pounds. It is slightly shorter and heavier than the Mk. VIIA1 round for this gun.

g. SHOT, Fixed, Target Practice, 3-Inch (15-Pdr.) Gun, M1902MI. This practice round consists of the primer M28A1 and a propelling charge of 4.75 pounds contained in the brass cartridge case Mk. IIM2 which is crimped rigidly to a solid cast iron or steel projectile. The projectile is of the "short-point" type, having an ogival radius of 2.4 calibers. The rotating band is $\frac{1}{2}$ inch wide with no cannelures. The base of the projectile may be provided with a tracer in which case the cartridge is so marked. This round is 33.86 inches long when fitted with a cast iron projectile, and 33.20 inches long when fitted with a steel projectile. The weight of the round is 26.83 pounds.

h. AMMUNITION, Blank, 3-Inch (15-Pdr.) Gun, M1902MI, and 3-Inch AA Guns, M1918 (All Models), M1, and M3. This blank round consists of a primer (PRIMER, 100-grain, M1B1A1) and a charge of 1 pound of black powder enclosed in a cloth bag in the brass cartridge case, M13, which is closed with a felt wad and a pulpboard closing cup. The round has no projectile. It is 6.625 inches long and weighs 4.21 pounds. The markings on the side of the cartridge consist of the words **BLANK CHARGE**, the weight of the charge, the type and model of gun in which the round is to be fired, and the lot number.

CAUTION: Rounds in which the closing cup is damaged or displaced will not be fired. They will be handled with care until disposed of in accordance with TM 9-1900.

i. CARTRIDGE, Drill, M4A1, w/FUZE, Dummy, 21-Sec., M42A1, 3-Inch AA Guns, M1918 (All Models), M1, and M3, or 3-Inch (15-Pdr.) Gun, M1902MI. This drill round (fig. 53) is used in training and drill in service of the piece. It is similar in size and shape to the service round described in paragraph 47 h. It consists of a cast bronze body, a detachable base and a dummy fuze (FUZE, dummy, 21-sec., M42A1). The base and the fuze are fastened to the body by set screws. The round is 31.90 inches long and weighs 24.00 pounds. The center of gravity is 17.43 inches from the base end. This cartridge is identified by its markings on the base showing the caliber and the model number of the gun with which the cartridge is to be used for drill purposes. The fuze

3-INCH SEACOAST GUN MATERIEL

is identified by its markings and the hole in the side through to the central cavity. The round is completely inert.

j. CARTRIDGE, Drill, M4, w/FUZE, Dummy, 21-Sec., M42A1, 3-Inch AA Guns, M1918 (All Models), M1, and M3, or 3-Inch (15-Pdr.) Gun M1902MI. This drill round is similar to the drill round described in paragraph 47 i, except for a slight difference in design at that portion of the body which simulates the bourrelet of the service round. This round is fitted with FUZE, dummy, 21-sec., M42A1, which can be identified by its markings and the hole in the side through to the central cavity.

k. CARTRIDGE, Drill, 3-Inch (15-Pdr.) Gun, M1902MI. This drill round is similar in shape to the drill rounds described in paragraphs, 47 i and j, except that it has no dummy fuze. A nose plug is screwed into the nose of the round and riveted. The base is screwed to the bottom of the round and held in place by a setscrew. The round is 33.1 inches long and weighs 25.5 pounds. Three of these rounds are furnished with the M1902MI gun, sub-caliber-and-drill cartridge kit described in Chapter 5.

48. AMMUNITION FOR THE GUN, 3-INCH (15-PDR.), M1903.

a. General. Ammunition listed in Table II is designed especially to fit the cartridge chamber of the GUN, 3-inch (15-pdr.), M1903. With the exception of drill rounds as shown in the table this ammunition is not authorized for use in any other model of gun. Ammunition for the M1903 gun can be identified only by the markings on the base (also on the body in earlier types) of the cartridge case showing its caliber and model number, "3-inch MARK IM2," and by the length (2 in.) of the shoulder of the cartridge case. See also paragraph 45 e and the following subparagraphs.

b. SHELL, Fixed, H.E., M42A1, w/FUZE, P.D., M48, 3-Inch (15-Pdr.) Gun, M1903. This high explosive round (fig. 54) is designed for use against submarines, mine sweepers and invasion craft. It consists of the primer, M28A1, and a propelling charge of smokeless powder contained in the brass cartridge case Mk. IM2 which is crimped rigidly to the shell. The shell has an ogival radius of 7 calibers. The bursting charge consists of 0.86 pound of trinitrotoluene (TNT). Alternative bursting charges may be 0.77 pound of amatol or 0.88 pound of trimonite. The rotating band is 1 inch wide and has 2 cannellures. A setscrew in the ogive holds the BOOSTER, M20 or M20A1, in place. As shipped, this projectile is fitted with the M48 impact type fuze which may be set for either superquick or delay action. The round is

AMMUNITION

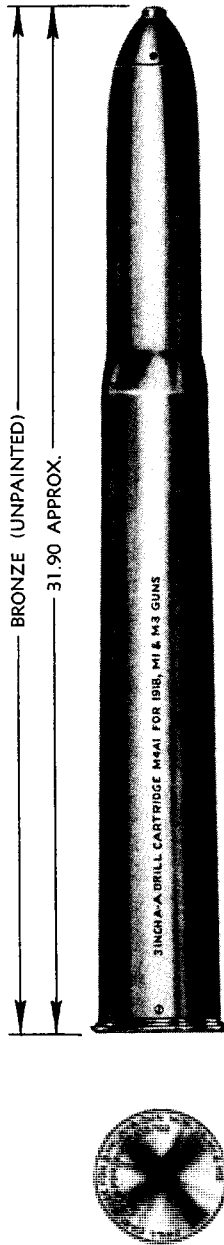

RA PD 2118

Figure 53—Cartridge, Drill, M41A1, w/Fuze, Dummy, 21-Sec., M42A1, 3-inch AA Guns, M1918 (All Models), M1, and M3, or 3-inch (15-Pdr.) Gun, M1902M1

3-INCH SEACOAST GUN MATERIEL

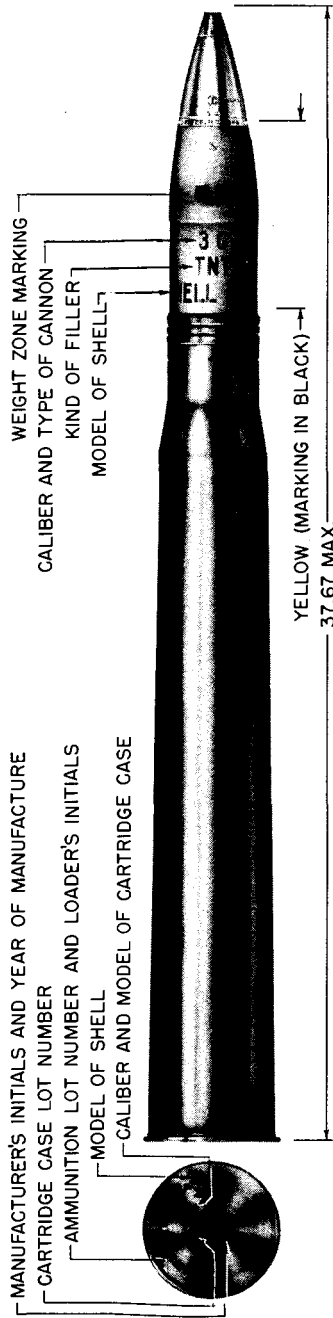

RA PD 4536

Figure 54—Shell, Fixed, H. E., M42A1, w/Fuze, P. D., M48, 3-inch (15-Pdr.) Gun, M1903

AMMUNITION

37.67 inches long, weighs 26.78 pounds and has a propelling charge weighing 4.87 pounds. After removing the packing material and setting the fuze (par. 49 d), the round is ready for firing.

c. **SHELL, Fixed, H.E., M42, w/FUZE, P.D., M48, 3-Inch (15-Pdr.) Gun, M1903.** This high explosive round is similar to the shell described in paragraph 47 b, except for slight differences in the internal details. This round is 37.67 inches long and weighs 26.70 pounds.

d. **SHELL, Fixed, H.E., M1915, 3-Inch (15-Pdr.) Gun, M1903.** This high explosive round is designed for use against heavy materiel targets. It consists of the primer, M28A1, and a propelling charge of 5 pounds of smokeless powder contained in the brass cartridge case, Mk. IM2, which is crimped rigidly to the heavy-walled projectile having an ogival radius of 7 calibers. This projectile has a bursting charge of 0.48 pound of explosive D. The base-detonating fuze (FUZE, B.D., Mk. V) is fitted to the base of the projectile and covered by the base cover, hence it is not visible. This round is 38.35 inches long, weighs 28.9 pounds. It is identified by the marking and the narrow (½ in.) rotating band without cannelures. After removing the packing material, the round is ready for firing.

e. **SHELL, Fixed, H.E., Mk. I, 3-Inch (15-Pdr.) Gun, M1903.** This high explosive round was formerly listed as SHELL, fixed, H.E., Mk. I, 3-inch AA guns, M1917, M1917MI, M1917A1, and M1917MIA1. For use in the 3-inch (15-pdr.) gun, M1903, it is fitted with FUZE, combination, 21-sec., M1907M, and BOOSTER, M20, or M20A1, and the marking appropriately changed. This round is 38.46 inches long and weighs 28.9 pounds. The projectile contains a bursting charge of 1.72 pounds of TNT and the propelling charge consists of 5 pounds of smokeless powder.

f. **PROJECTILE, Target Practice, Mk. VIIA1, 3-Inch (15-Pdr.) Gun, M1903.** This practice round (fig. 55) consists of the primer, M28A1, and a propelling charge of 4.75 pounds of smokeless powder contained in the brass cartridge case, Mk. IM2, which is crimped rigidly to the projectile of steel or cast iron. The projectile which has a cavity in the base is inert (contains no explosive) and has no fuze. It has an ogival radius of 7 calibers and is similar in shape and ballistic properties to the fuzed, high explosive service projectile described in paragraph 47 b. The rotating band is 1 inch wide and has 2 cannelures. The round is 37.89 inches long and weighs 28.7 pounds.

g. **PROJECTILE, Target Practice, Mk. VII, 3-Inch (15-Pdr.) Gun, M1903.** This practice round is similar to the Mk. VIIA1 practice

3-INCH SEACOAST GUN MATERIEL

round described in paragraph 47 f. It has the same type cartridge case, Mk. IM2, but there are slight differences in the design of the projectile. The projectile of this round, either cast iron or steel, is solid (has no cavity), and the rotating band is ½-inch wide and has no cannelures. The round is 37.69 inches long (cast iron) or 37.02 inches (steel), and weighs 28.8 pounds. It is slightly shorter and heavier than the Mk. VIIA1 round for this gun.

h. SHOT, Fixed, Target Practice, 3-Inch (15-Pdr.) Gun, M1903.

This practice round consists of the primer, M28A1, and a propelling charge of 4.75 pounds of smokeless powder contained in the brass cartridge case (Mk. IM2) which is crimped rigidly to a solid cast iron or steel projectile. The projectile is of the short point type having an ogival radius of 2.4 calibers. The rotating band is ½ inch wide with no cannelures. The base of the projectile may be provided with a tracer, in which case it is so marked. This round is 37.36 inches long when fitted with a cast iron projectile, and 36.70 inches long when fitted with a steel projectile. It weighs 28.89 pounds.

i. AMMUNITION, Blank, 3-Inch (15-Pdr.) Gun, M1903, and 3-Inch AA Guns, M1917 (All Models), M1925MI, M2, and M4.

This blank round consists of a primer (PRIMER, 100-grain, M1B1A1) and a charge of 1 pound of black powder, enclosed in a cloth bag, in the brass cartridge case, M12, which is closed with a felt wad and a pulpboard closing cup. The round has no projectile. It is 6 inches long and weighs 4.47 pounds. The markings on the side of the cartridge consist of the words "BLANK CHARGE," the weight of the charge, the type and model of gun in which the round is to be fired, and the lot number.

CAUTION: Rounds in which the closing cup is damaged or displaced will not be fired. They will be handled with care until disposed of in accordance with TM 9-1900.

j. CARTRIDGE, Drill, M3A1, w/FUZE, Dummy, 21-Sec., M42A1, 3-Inch AA Guns, M1917 (All Models), M2, and M4, or 3-Inch (15-Pdr.) Gun, M1903.

This drill round (fig. 56) is used in training and service of the piece. It is similar in size and shape to the service round described in paragraph 47 b. It consists of a cast bronze body, a detachable base and a dummy fuze (FUZE, dummy, 21-sec., M42A1). The base and the fuze are fastened to the body by setscrews. The round is 35.55 inches long and weighs 27 pounds. The center of gravity is 18.8 inches from the base end. The cartridge is identified by the markings on the base showing the caliber and the model numbers of the guns with which the cartridge is to be used for drill purposes. The fuze is identified by its markings and the hole in the side through to the central cavity. The round is completely inert.

RA PD 4537

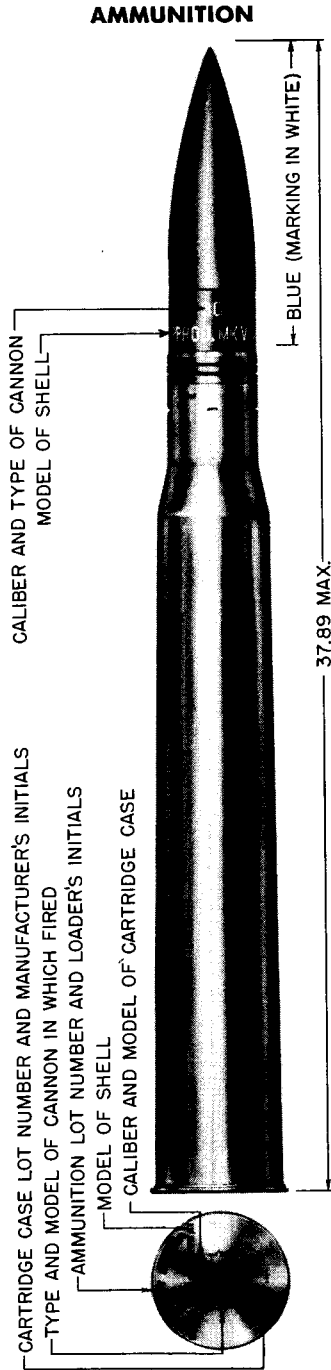
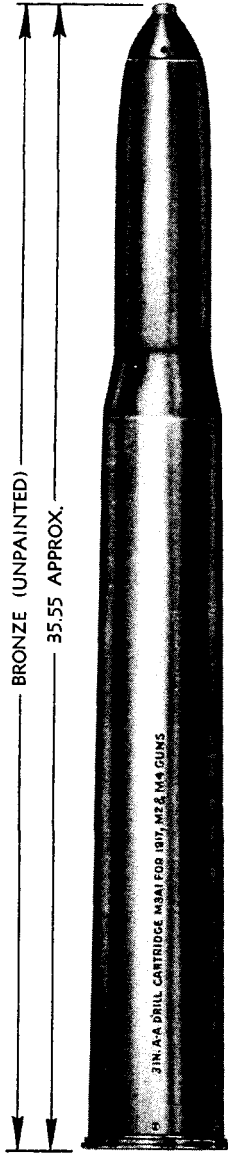

Figure 55—Projectile, Fixed, Target Practice, Mk. VIIA1, 3-inch (15-Pdr.) Gun, M1903

3-INCH SEACOAST GUN MATERIEL



RA PD 2119

Figure 56—Cartridge, Drill, M3A1, w/Fuze, Dummy, 21-Sec., M42A1, 3-inch AA Guns, M1917 (All Models), M1925M1, M2, and M4, or 3-inch (15-Pdr.) Gun, M1903

AMMUNITION

k. **CARTRIDGE, Drill, M3, w/FUZE, Dummy, 21-Sec., M42A1, 3-Inch AA Guns, M1917 (All Models), M1925M1, M2, and M4, or 3-Inch (15-Pdr.) Gun, M1903.** This drill round is similar to the drill round described in paragraph 47 j, except for a slight difference in design at that portion of the body which simulates the bourrelet of the service round. This round is fitted with the FUZE, dummy, 21-sec., M42A1, which can be identified by its markings and the hole in the side leading to the central cavity.

l. **CARTRIDGE, Drill, 3-Inch (15-Pdr.) Gun, M1903.** This drill round is similar in shape to the drill rounds described in paragraph 47 j and k, except that it has no dummy fuze. A nose plug is screwed into the nose of the round and riveted. The base is screwed to the bottom of the round and held in place by a setscrew. The round is 36.8 inches long and weighs 29.75 pounds. Three of these rounds are furnished with the M1903 gun subcaliber-and-drill cartridge kit described in chapter 5.

49. FUZES.

a. **General.** A fuze is a mechanical device used with a projectile to explode it at the time and under the circumstances desired. Fuzes may be classified as time or impact, according to manner of functioning. A further division, as to type of action after impact, is superquick, and nondelay.

b. **Arming.** Artillery fuzes are armed by centrifugal force, or by centrifugal force and setback, and become fully armed almost immediately after the projectile leaves the muzzle of the gun. Time fuzes in a strict sense are always in an armed condition; they start to function, as a result of setback, at the instant of firing the gun.

c. **Boresafe Fuzes.** Dependent upon manner of arming, certain fuzes are considered boresafe. A boresafe fuze is one in which the explosive train is so interrupted that prior to firing and while the projectile is still in the bore of the cannon, premature action of the bursting charge is prevented should any of the more sensitive elements, primer and/or detonator, function prematurely. Boosters containing a mechanical interrupter are generally used with time fuzes in order to provide boresafety.

NOTE: No attempt will be made to disassemble any fuze. The only authorized operation is that of setting the fuze (point-detonating fuzes only). Fuze settings may be changed at will. If projectiles are not fired, fuzes will be reset to their original position; that is, to S.Q. on the M48 fuze and to S (safe) on the M1907M fuze.

d. **FUZE, P.D., M48.**

(1) **DESCRIPTION.** This fuze, assembled to the round as issued, is of the impact type containing two actions, superquick and delay. On

3-INCH SEACOAST GUN MATERIEL

the side of the fuze near the base is a slotted "setting sleeve" and two registration lines, one parallel to the axis of the fuze, the other at right angles thereto. The line parallel to the axis is marked "S.Q.," the other "DELAY." To set the fuze, the setting sleeve is turned so that the slot is alined with "S.Q." or "DELAY," whichever is required. The setting may be made or changed at will with a screwdriver or other similar instrument any time before firing, even in the dark, by noting the position of the slot—parallel to the fuze axis for "S.Q.," at right angles thereto for "DELAY." It should be noted that in this fuze, even though set SUPERQUICK, the delay action will operate should the superquick action fail to function. This fuze is classified as boresafe.

(2) **PREPARATION FOR FIRING.** Prior to firing, it is necessary only to set the fuze as described above, and this only when delayed action is required. As issued, the fuze is set SUPERQUICK.

e. FUZE, Combination, 21-Sec., M1907M.

(1) **DESCRIPTION.** This is a combination fuze containing two types of action, percussion and time. The percussion action is always operative and will function on impact unless prior functioning has been caused by the time action. The time train ring is similar to that of other powder time train fuzes and is graduated for 21.2 seconds. In the particular case of zero (0) setting, the fuze functions just beyond the muzzle of the cannon. Because the powder time train is adversely affected by moisture, every effort will be made to keep the fuze dry. This fuze is not classified as boresafe.

(2) **PREPARATION FOR FIRING.** The waterproof fuze cover must first be removed. If percussion action is required, the graduated time train ring is left safe (S) as shipped, or set for a time greater than the expected time of flight. If time action is required, the graduated time train ring is set for the required time of burning by means of a fuze setter.

f. **FUZE, B.D., Mk. V.** This fuze is of the base-detonating, non-delay, impact type used for targets offering less resistance than that of heavy armorplate. Due to the arrangement of the explosive elements, it is classified as boresafe. Being assembled in the base of the projectile and covered by the base cover, the fuze is not visible.

50. PACKING.

a. **General.** Fixed rounds of ammunition for these guns are packed in individual moisture-resistant fiber containers in wooden packing boxes (fig. 57) or without individual containers in sealed, metal-lined, wooden packing boxes. While the weight of the individual round varies

AMMUNITION

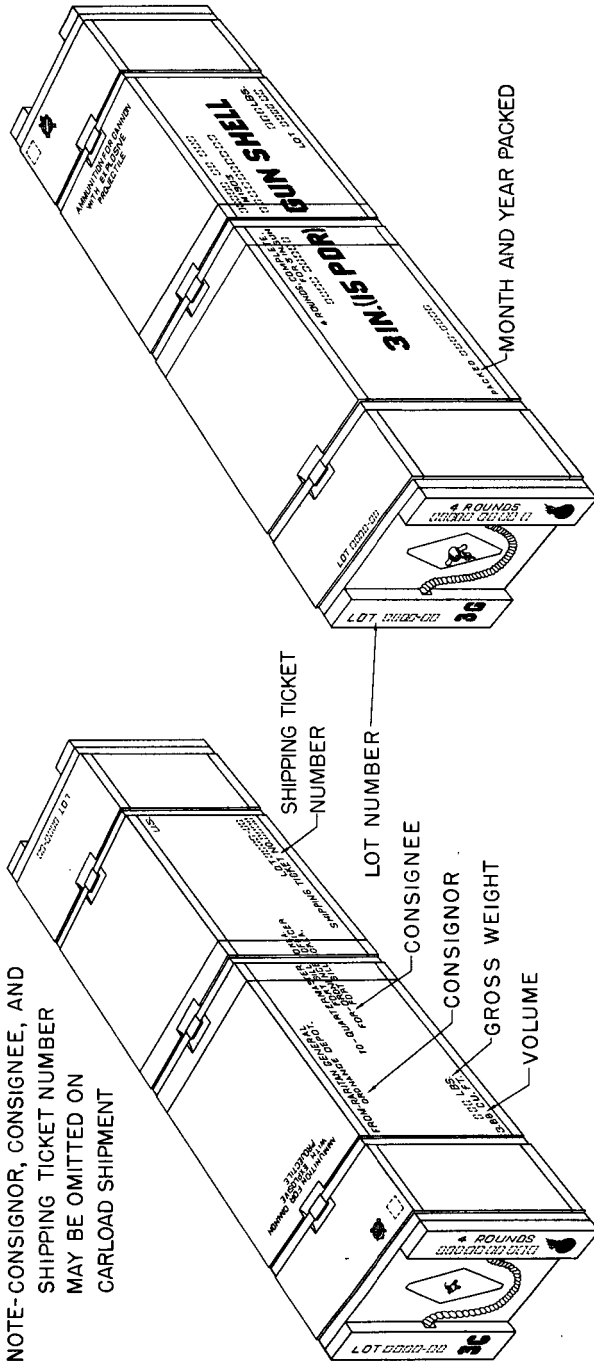

RA PD 4538

Figure 57—Box, Packing, for Shell, Fixed, H. E., M42A1, w/Fuze, P. D., M48, 3-inch (15-Pdr.) Gun, M1903

3-INCH SEACOAST GUN MATERIEL

somewhat, dependent upon type and model, the following data are considered representative for estimating weight and volume requirements.

	Weight (pounds)	Volume (cubic feet)
Ammunition for the M1902MI gun:		
Complete round without packing.....	24.85
Four rounds in separate containers in box.	152.4	3.11
Over-all dimensions of box (in.):		
40 $\frac{3}{16}$ by 11 $\frac{9}{16}$ by 11 $\frac{9}{16}$		

Ammunition for the M1903 gun:		
Complete round without packing.....	26.70
Four rounds in separate containers in box.	166.8	3.88
Over-all dimensions of box (in.):		
43 $\frac{3}{8}$ by 12 $\frac{3}{8}$ by 12 $\frac{3}{8}$		

Ammunition for either M1902MI or M1903 gun:

Blank ammunition is packed in individual containers, 10 containers (10 rounds) per box.

For oversea shipment, 4 rounds without containers are packed in a metal-lined box.

b. **Marking.** Representative marking is shown in figure 57. A blue band painted on packing boxes indicates that the box contains practice ammunition.

51. SUBCALIBER AMMUNITION.

For subcaliber practice with these guns, CARTRIDGE, subcaliber, caliber .30, M1925, is provided as ammunition to be used with a special rifle barrel which is fitted into a drill cartridge as part of a subcaliber and drill cartridge kit. These kits are described in Chapter 5.

52. FIELD REPORT OF ACCIDENTS.

Any serious malfunctions of ammunition must be promptly reported to the ordnance officer under whose supervision the materiel is maintained or issued, see paragraph 7, AR 45-30.

Chapter 4

SPARE PARTS AND ACCESSORIES

	Paragraph
Spare parts	53
Accessories	54
Book, artillery gun	55
Brush, slush	56
Paulin	57
Scraper	58
Sponge and staff	59
Tompson, front sight bracket	60
Wrenches	61

53. SPARE PARTS.

a. Spare parts are supplied to the using arm for replacement of those parts most likely to become broken, worn, or otherwise unserviceable. Standard Nomenclature Lists of spare parts, which should be maintained as sets, will not be published for this materiel. However, lists of the parts of the guns which are most likely to fail and which are commonly issued to battery personnel for repair purposes will follow in this chapter. These lists do not pertain to specific batteries but are intended as guides for the stocking of spare parts. Repair parts for the carriages must be procured and replaced by ordnance personnel. An inventory of the parts stocked at the battery should be kept at all times. Sets of spare parts should be maintained complete at all times and should be kept clean and oiled.

Spare Parts for 3-Inch (15-Pdr.) Gun M1902MI

Piece Mark
or
Drawing No.

Item
SPARE PARTS

PARTS, spare, Gun, 3-in. (15-pdr.), M1902MI, set

(Consisting of:

55-4-26A	2 BAR, operating
C3652	2 CASE, firing
A12878	2 DETENT, trigger shaft
55-4-24A	2 EXTRACTOR
A12880	2 FOLLOWER, firing spring, assembly
A12869	2 LEVER, cocking
....	1 LINK, cocking, complete
....	2 PIN, extractor, assembly

3-INCH SEACOAST GUN MATERIEL

Piece Mark
or
Drawing No.

Item

SPARE PARTS

PARTS, spare, Gun, 3-in. (15-pdr.), M1902MI, set
(Consisting of:

C3654	2 PIN, firing
A12530	2 SEAR
B8291	2 SHAFT, trigger
A12886	2 SPRING, breechblock latch
55-4-26E	2 SPRING, firing
A12222	2 SPRING, sear)

Spare Parts for 3-Inch (15-Pdr.) Gun M1903

Piece Mark
or
Drawing No.

Item

SPARE PARTS

PARTS, spare, Gun, 3-in. (15-pdr.), M1903, set
(Consisting of:

55-8-6H	2 BAR, operating
C3652	2 CASE, firing
A12878	2 DETENT, trigger shaft
55-8-9A	2 EXTRACTOR
A12866	2 FOLLOWER, firing spring, assembly
A12869	2 LEVER, cocking
C3653	2 PIN, firing
A12530	2 SEAR
B8255	2 SHAFT, trigger
A12886	2 SPRING, breechblock latch
A12221	2 SPRING, firing
A12222	2 SPRING, sear)

54. ACCESSORIES.

a. General. Accessories include the tools and equipment required for such disassembling and assembling as the using arm is authorized to perform, and for the cleaning and preserving of the gun carriage, sighting and fire control equipment, ammunition, etc. They also include chests, covers, tool rolls and other items necessary to protect the materiel when it is not in use. Accessories should not be used for purposes other than those prescribed and when not in use should be properly stored. There are a number of accessories whose names or general characteristics indicate their uses. Others embodying special features or having special uses are described in the following paragraphs.

SPARE PARTS AND ACCESSORIES

55. BOOK, ARTILLERY GUN.

The gun book (O.O. Form 5825) is used to keep an accurate record of the materiel, and remains with the piece regardless of where it may be sent. It includes records of assignments, the battery commander's daily record, and the inspector's record of ammunition, as well as forms to be filled out in case of premature explosions. This book should be in the possession of the organization at all times. It is the sole responsibility of the battery commander as to the completeness of the record and as to the whereabouts of the book. It must also contain the date of issuance of the materiel, to and by whom issued, and the place where issued. If a new cannon is installed on the carriage, all data in the old book with reference to sights, carriage, etc., must be copied into the new gun book before the old gun book is relinquished.

56. BRUSH, SLUSH.

The slush brush is a cylindrical piece of wood to which is attached a woolen pad. It is used to coat the rifling of the gun with slushing compound for the prevention of rust and decomposition.

57. PAULIN.

Paulin is an olive-drab cotton duck covering used to cover the gun when the gun is not in use.

58. SCRAPER.

The scraper is used to scrape corrosion and rust preventive compound from the bore of the gun prior to cleaning and slushing operations. It should not be used for scraping copper deposits from the bore. Decopering the bore is prohibited. The scraper consists of a semicircular steel blade which is secured to one end of a socket with a bronze nut. The staff is screwed into the other end of the socket.

59. SPONGE AND STAFF.

The sponge is a carpet-covered cylindrical wooden head. The sponge head is attached to staff B (60 in. long) and staff C (120 in. long). The sponge and staff assembled is 180 inches long and is used for sponging the bore of the gun. A thickness of burlap (fig. 58) is wrapped around the sponge when lubricating the bore.

60. TOMPION, FRONT SIGHT BRACKET.

The front sight bracket tompion is a wooden plug which fits the front sight bracket. The tompion protects the bracket when the sight is not mounted.

3-INCH SEACOAST GUN MATERIEL



RA PD 33411

Figure 58—Lubricating Bore

SPARE PARTS AND ACCESSORIES**61. WRENCHES.**

a. The filling plug and square screwdriver wrench (fig. 59, No. 1) is a double-end wrench. The small end with $\frac{5}{8}$ -inch opening is used on the recoil cylinder filling plugs while the large end with $\frac{3}{4}$ -inch opening is used on the square screwdrivers.

b. The piston rod wrench (fig. 59, No. 2) is a double-end wrench. The large end is used on piston rod and compressor nuts while the small end is used on the pedestal bolts.

c. The shield bolt, throttling bar, and piston rod wrench (fig. 59, No. 3) is a double-end wrench. The small end is used on the cap square, shield bolts, and throttling bar.

d. The drain plug wrench (fig. 59, No. 4) is a socket type wrench, 15 inches long. One end has a square opening (0.64 in.) that fits the drain plug on the recoil cylinder while the other end has a T-shaped handle.

e. The pivot yoke and recoil cylinder wrench (fig. 59, No. 5) is a hook spanner type wrench used on pivot yoke nut and recoil cylinder.

f. The recoil cylinder head and follower wrench (fig. 59, No. 6) are of the face spanner type wrench used on the recoil cylinder head and follower.

g. The filling plug wrench (fig. 59, No. 7) is a socket type wrench $6\frac{3}{4}$ inches long. It is used on the filling plugs of the recoil cylinder for the 3-inch (15-pdr.) gun, M1903.

3-INCH SEACOAST GUN MATERIEL

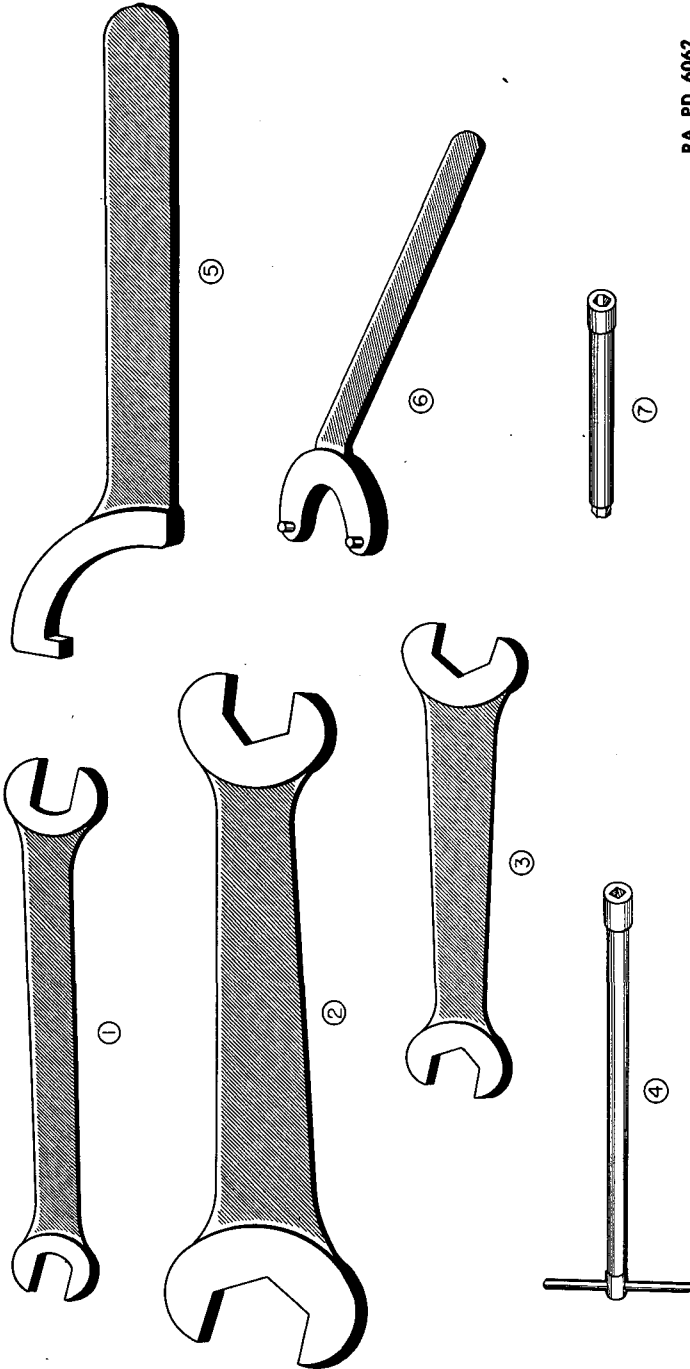

RA PD 6062

Figure 59—Tools

Chapter 5

SUBCALIBER EQUIPMENT

	<i>Paragraph</i>
Purpose	62
Materiel	63
Installation	64
Operation	65
Care and maintenance.....	66

62. PURPOSE.

Subcaliber equipment is used for training purposes only, to provide practice in laying and firing the 3-inch gun materiel. The use of smaller bore ammunition prevents wear on the regular piece during practice and is less costly. Although the handling and loading, as well as the range obtained, differ from those of the regular piece, the elevating, traversing, sighting, etc., are adequate for instructional purposes.

63. MATERIEL.

a. Subcaliber equipment is stored in a Subcaliber and Drill Cartridge Kit which contains the following:

- | | |
|--------------------------|------------------------------|
| One cleaning brush | Two flat-head special screws |
| Three drill cartridges | Two extractor springs |
| One subcaliber cartridge | One slotted tip |
| One extension piece | One extra base |
| One cleaning rod | One storage chest |

b. **Cartridge, Drill.** The drill cartridge (fig. 60) is a dummy cartridge for use in drilling cannoneers in the service and rapidity of loading the gun. It is a bronze casting of the shape and dimensions of a service round of fixed ammunition. The regular service round empty cartridge cases may be used for drill purposes in lieu of the drill cartridges.

c. **Cartridge, Subcaliber.**

(1) **GENERAL.** The subcaliber cartridge (fig. 60) is used for subcaliber practice. It consists of a caliber .30 rifle barrel mounted axially in a bronze subcaliber cartridge case, and resembles in weight and exterior dimensions the service ammunition regularly used with the gun. The breech end of the rifle barrel is screwed into the base of the subcaliber cartridge, while the muzzle end is threaded to take the ogival-shaped bronze head, which accurately fits the bore of the 3-inch gun at the front end of the subcaliber cartridge case, and is capable of longitudinal motion to allow for expansion of the barrel when it becomes heated.

3-INCH SEACOAST GUN MATERIEL

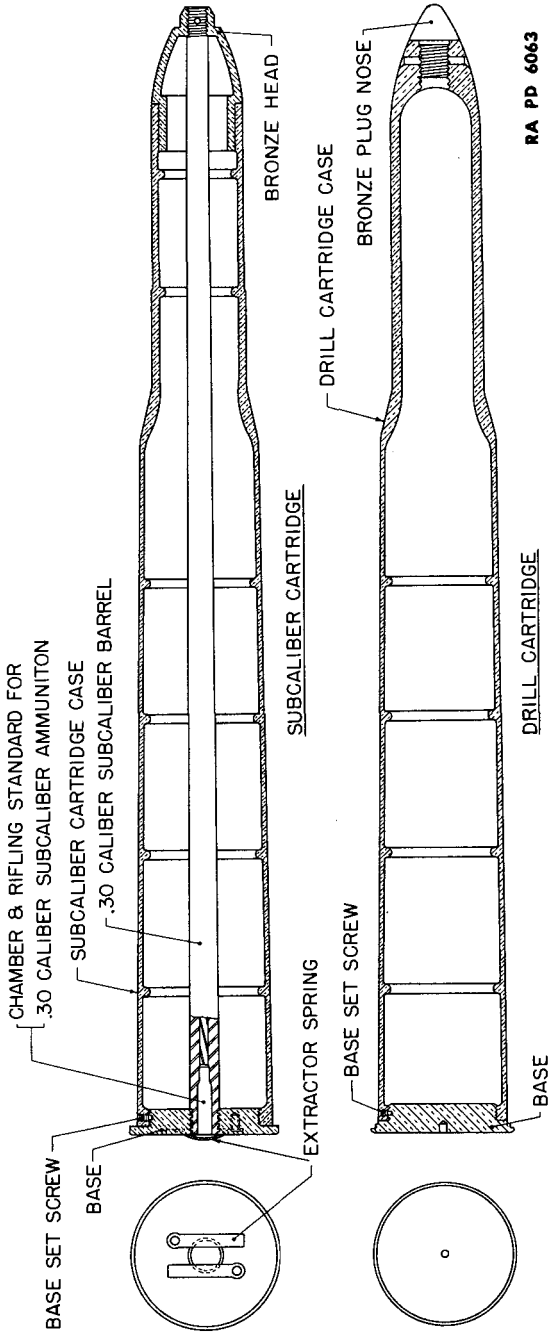

Figure 60—Subcaliber and Drill Cartridge

SUBCALIBER EQUIPMENT

d. **Extractor Spring.** Two extractor springs are provided for extracting the subcaliber ammunition from the caliber .30 barrel. They are secured to the base of the 3-inch subcaliber cartridge by two flat-head special screws so that the springs catch the rim of the caliber .30 subcaliber cartridge as it is inserted into the caliber .30 barrel.

64. INSTALLATION.

To mount the subcaliber cartridge in the bore of the gun proceed as follows:

a. Chamber and bore of both the subcaliber rifle barrel and of the 3-inch gun must be clean. A caliber .30 subcaliber cartridge is inserted in the chamber of the subcaliber rifle barrel until the rim of the cartridge comes in contact with the extractor spring (fig. 61, No. 3). The 3-inch subcaliber cartridge is then inserted and pushed home in the gun. The breech is then closed after making sure the rim of the caliber .30 cartridge is still in contact with the extractor springs. The face of the breechblock coming in contact with the caliber .30 subcaliber cartridge shoves it to its seat and at the same time compresses the extractor springs.

b. **Alternate Method of Installation.** To mount the subcaliber cartridge in the bore of the gun proceed as follows: Remove the gun extractor to prevent the breechblock from defacing the base of the subcaliber cartridge. Chamber and bore of both the subcaliber rifle barrel and of the 3-inch gun must be perfectly clean. The 3-inch subcaliber cartridge is inserted and pushed home in the gun. The subcaliber ammunition (.30 cal. subcaliber cartridge) is then inserted in the chamber of the subcaliber rifle barrel until the rim of the .30 caliber cartridge comes in contact with the extractor springs. The breech of the gun is then closed. The face of the breechblock coming in contact with .30 caliber cartridge shoves it to its seat and at the same time compresses the extractor springs.

NOTE: Under no circumstances will the subcaliber cartridge be used as a drill cartridge, as such use invariably results in dishing the head of the cartridge, thus increasing the head space for the .30 caliber cartridges and rupturing their cases.

c. **Adjustment.** The subcaliber cartridge is in correct adjustment when it is inserted in the bore of the gun, the caliber .30 cartridge inserted in the chamber of the caliber .30 rifle barrel and the breech closed. The gun is then ready to fire.

d. **Disassembly.** Open the breech and remove the 3-inch subcaliber cartridge the same as a round of regular ammunition. The extractor springs will throw the empty caliber .30 cartridge case far enough to the rear to permit its removal with the fingers.

3-INCH SEACOAST GUN MATERIEL

65. OPERATION.

a. Operation of the subcaliber cartridge is identical to the firing of a round of regular ammunition except the operation of inserting and removing the caliber .30 cartridges from the rifle barrel in the 3-inch subcaliber cartridge.

b. To Load the Subcaliber Cartridge:

(1) Insert a round of caliber .30 subcaliber ammunition into the chamber of the rifle barrel in the 3-inch subcaliber cartridge (fig. 61, No. 3).

(2) Depress the gun to zero elevation.

(3) Insert the 3-inch subcaliber cartridge into the chamber of the gun (fig. 61, No. 4).

(4) Close the breech.

c. To Fire Subcaliber Cartridge:

(1) Elevate the gun as with regular ammunition and fire, observing the same precautions as are observed for firing regular ammunition.

(2) Remove the 3-inch subcaliber cartridge after each round of subcaliber ammunition has been fired; also remove the empty caliber .30 cartridge case from the 3-inch subcaliber cartridge.

d. Alternate Method of Operation.

(1) Operation of the subcaliber cartridge is identical to the firing of a round of regular service ammunition, except during subcaliber practice the 3-inch subcaliber cartridge remains in the bore of the gun and only the empty .30 caliber subcaliber cartridge case is removed after firing each round of subcaliber ammunition.

(2) TO LOAD THE SUBCALIBER CARTRIDGE:

(a) Depress the gun to zero elevation.

(b) Insert the 3-inch subcaliber cartridge into the chamber of the gun.

(c) Insert a round of .30 caliber subcaliber ammunition into the chamber of the rifle barrel.

(d) Close the breech.

(3) TO FIRE THE SUBCALIBER CARTRIDGE:

(a) Elevate the gun as with regular ammunition and fire, observing the same precautions as are observed for firing regular service ammunition.

(b) Remove the empty .30 caliber cartridge case after each round of subcaliber ammunition has been fired, but do not remove the 3-inch subcaliber cartridge from the chamber of the gun.

SUBCALIBER EQUIPMENT

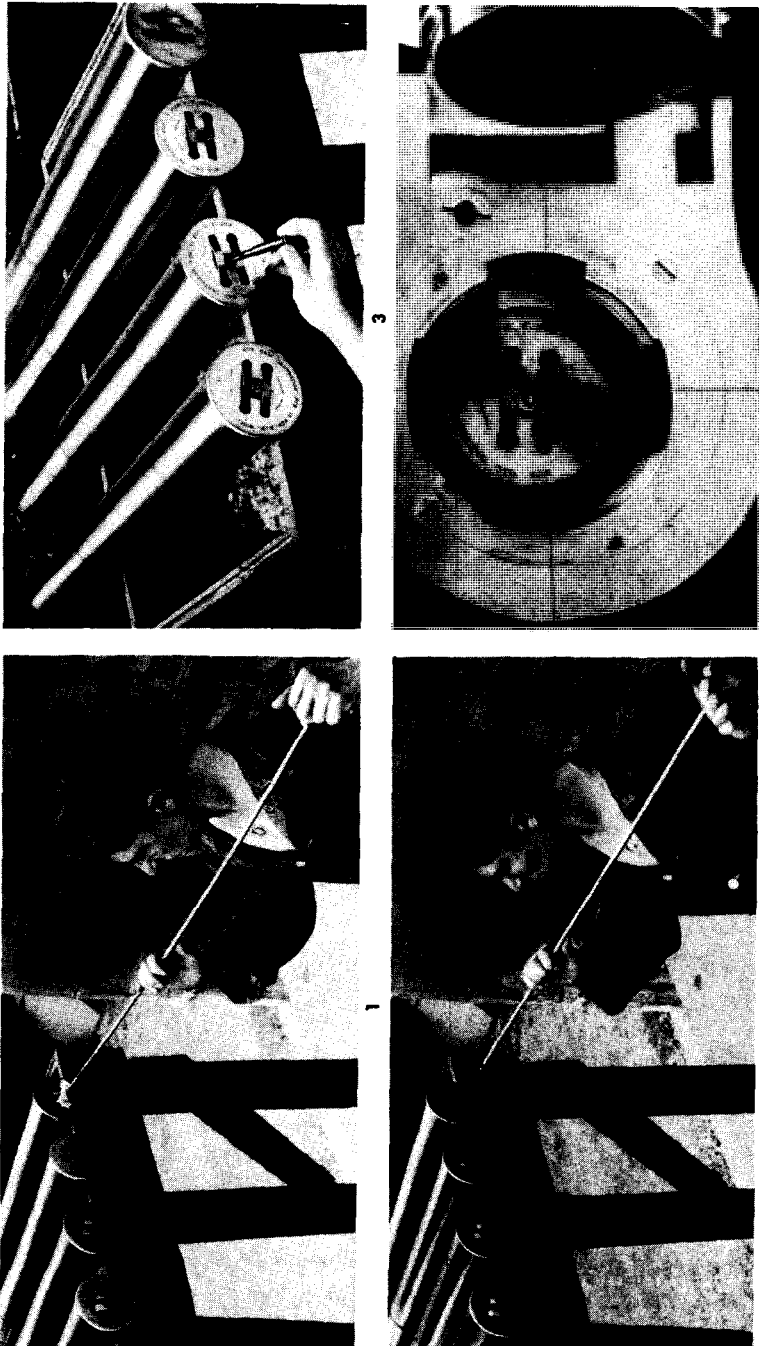

RA PD 33412

Figure 61—Method of Cleaning and Loading Subcaliber Cartridge

3-INCH SEACOAST GUN MATERIEL**66. CARE AND MAINTENANCE.**

The rifle barrel in the subcaliber cartridge should be cleaned carefully after use. The residue from smokeless powder, if not completely removed, corrodes the bore in a short time. The bore should be cleaned with a rag saturated with **CLEANER**, rifle bore, or a solution of soda water ($\frac{1}{2}$ lb of **SODA ASH**) (fig. 61, No. 1) to a gallon of boiling water and wiped dry with a clean rag. The bore is then oiled with a light coating of **OIL**, lubricating, preservative, light. A cleaning rod, a cleaning brush, and a slotted tip is provided for this purpose (fig. 61, Nos. 1 and 2). This process is done every day until sweating in the rifle barrel has stopped.

Chapter 6

PAINTING

	Paragraph
General	67
Preparing for painting	68
Painting metal surfaces	69
Removing paint	70
Painting lubricating devices	71

67. GENERAL.

Paint is used for preservation against rust, deterioration, corrosion and decay of metals and woods. Some paints adhere to metal surfaces better than others, the liquids of the first or base coat seeming to penetrate minute depressions or pits in the metal or to etch themselves into the surface and thus form a good bond for following coats. Paints stored in large containers must be well stirred before transfer to smaller containers.

a. All parts of the gun and carriage will be painted, with the exception of wearing or bearing parts and sliding surfaces. Groups normally considered to be wearing or bearing parts and sliding surfaces are:

All parts of breechblock	Piston rods
All parts of firing mechanism	Recoil slides
Extractors	Handles of cranks, handwheels, and clutches
Square ends of shafts	
Teeth of all gears	Azimuth and elevation scales and pointers
Traversing rollers	

b. The background of name and direction plates will be painted red, but the raised portions of the letters, figures, arrows, and rims are to be kept bright and free from paint. Name plates should never be removed from the carriage.

c. All paint should be well stirred before using. If too thick, it should be thinned with **TURPENTINE** or **THINNER**, but not to such an extent that the paint does not cover. The exact and proper thickness of each paint can be learned only by experience. If too thin, it often cracks in drying, and if too thick it becomes blistered, wrinkled, and unequal. The first coat may, however, be much thinner than any of the succeeding coats.

d. Ordnance materiel is ordinarily given one maintenance coat per year. With but few exceptions this materiel will be painted with **ENAMEL**, synthetic, olive drab, lusterless. The enamel may be applied

3-INCH SEACOAST GUN MATERIEL

over old coats of long oil enamel and oil paint previously issued by the Ordnance Department, if the old coat is in satisfactory condition for repainting. This enamel is used for both metal and wood surfaces, the primer base coat for metal being different from the primer base coat for wood.

e. Paints and enamels are usually issued ready for use and are applied by brush or spray. They may be brushed on satisfactorily when used unthinned in the original package consistency or when thinned no more than 5 percent by volume with THINNER. The enamel will spray satisfactorily when thinned with 15 percent by volume of THINNER. (Linseed oil must not be used as a thinner, since it will impart a luster not desired in this enamel.) If sprayed, it dries hard enough for repainting within ½ hour and dries hard in 16 hours.

f. Certain exceptions to the regulations concerning painting exist. Fire-control instruments, sighting equipment, and other items which require a crystalline finish will not be painted with olive-drab enamel.

68. PREPARING FOR PAINTING.

a. If the base coat on the materiel is in poor condition, it is more desirable to strip the old paint from the surface than to use sanding and touch-up methods. After stripping, it will then be necessary to apply a primer coat.

b. PRIMER, ground, synthetic, should be used on wood as a base coat for synthetic enamel. It may be applied either by brushing or spraying. It will brush satisfactorily as received, or after the addition of not more than 5 percent by volume of THINNER. It will dry enough to touch in 30 minutes, and hard in 5 to 7 hours. For spraying, it may be thinned with not more than 15 percent by volume of THINNER. Lacquers must not be applied to the PRIMER, ground, synthetic, within less than 48 hours.

c. PRIMER, synthetic, rust inhibiting, for bare metal, should be used on metal as a base coat. Its use and application is similar to that of PRIMER, ground, synthetic.

d. The success of a painting job depends partly on the selection of a suitable paint, but also upon the care used in preparing the surface prior to the painting. All parts to be painted must be free from rust, dirt, grease, kerosene, oil, and alkali, and must be dry and smooth.

69. PAINTING METAL SURFACES.

If metal parts are in need of cleaning, they should be washed in a liquid solution consisting of ½ pound of SODA ASH in 8 quarts of warm water, or an equivalent solution, then rinsed in clear water and

PAINING

wiped thoroughly dry. Wood parts in need of cleaning should be treated in the same manner, but the alkaline solution must not be left on for more than a few minutes and the surfaces should be wiped dry as soon as they are washed clean. When artillery equipment is in fair condition and only marred in spots, the bad places should be touched with ENAMEL, synthetic, olive drab, lusterless, and permitted to dry. The whole surface will then be sandpapered with PAPER, flint, No. 1, and a finish coat of ENAMEL, synthetic, olive drab, lusterless, applied and allowed to dry thoroughly before the materiel is used. If the equipment is in bad condition, all parts should be thoroughly sanded with PAPER, flint, No. 2, or equivalent, given a coat of PRIMER, ground, synthetic, and permitted to dry for at least 16 hours. They will then be sandpapered with PAPER, flint, No. 00, wiped free of dust and dirt, and a final coat of ENAMEL, synthetic, olive drab, lusterless, applied and allowed to dry thoroughly before the materiel is used.

70. REMOVING PAINT.

After repeated paintings, the paint may become so thick as to crack and scale off in places, presenting an unsightly appearance. If such is the case, remove the old paint as follows: Dissolve one pound of SODA, caustic (lye), for cleaning purposes, in 6 pints of hot water and add enough lime to give the solution the consistency of paint. Use the solution freshly mixed and apply to parts where paint is to be removed with a swab of cotton rags, or cotton waste, tied to the end of a stick. When the solution begins to dry on the surface, use a scraper to remove the old paint and complete the cleaning of the surface with a mop and water. If one application is not sufficient to loosen the paint, apply a second coat. It is important that every trace of lye or other paint remover be completely rinsed off and that the equipment be perfectly dry before repainting is attempted. It is preferable that the use of lye solutions be limited to iron or steel parts. If used on wood, the lye solutions must not be allowed to remain on the surface for more than a minute before being thoroughly rinsed off and the surface wiped dry with rags. Crevices or cracks in wood should be filled with putty and the wood sandpapered before refinishing.

71. PAINTING LUBRICATING DEVICES.

Oil cups, grease fittings, oilholes, and similar lubricating devices, as well as a circle about $\frac{3}{4}$ inch in diameter at each point of lubrication will be painted with ENAMEL, red, water resisting, in order that they may be readily located.

3-INCH SEACOAST GUN MATERIEL

Chapter 7

MATERIEL AFFECTED BY GAS

	Paragraph
Protective measures	72
Cleaning	73
Decontamination	74

72. PROTECTIVE MEASURES.

a. When materiel is in constant danger of gas attack, unpainted metal parts must be lightly coated with engine oil. Instruments are included among the items to be protected by oil from chemical clouds or chemical shells, but ammunition is excluded. Care will be taken that the oil does not touch the optical parts of instruments or leather or canvas fittings. Materiel not in use will be protected with covers as far as possible. Powder will be kept in sealed containers.

b. Ordinary fabrics offer practically no protection against mustard gas or lewisite. Rubber and oilcloth, for example, will be penetrated within a short time. The longer the period during which they are exposed, the greater the danger of wearing these articles. Rubber boots worn in an area contaminated with mustard gas may offer a grave danger to men who wear them several days after the bombardment. Impermeable clothing will resist penetration more than an hour, but should not be worn longer than this.

73. CLEANING.

a. All unpainted metal parts of materiel that have been exposed to any gas except mustard and lewisite must be cleaned as soon as possible with SOLVENT, dry-cleaning, or ALCOHOL, denatured, and wiped dry. All parts should then be coated with engine oil (except fire-control equipment). Clean all shiny exterior surfaces, the bore, the breech chamber, and the parts of the breech mechanism.

b. Ammunition which has been exposed to gas must be thoroughly cleaned before it can be fired. To clean ammunition use AGENT, decontaminating, noncorrosive, or if this is not available, strong soap and cool water. After cleaning, wipe all ammunition dry with clean rags. Do not use AGENT, dry-powdered, decontaminating (chloride of lime) (used for decontaminating certain types of materiel on or near ammunition supplies), as flaming occurs through the use of chloride of lime on liquid mustard.

MATERIEL AFFECTED BY GAS

74. DECONTAMINATION.

For the removal of liquid chemicals (mustard, lewisite, etc.) from materiel, the following steps should be taken:

a. Protective Measures.

(1) For all these operations a complete suit of impermeable clothing and a service gas mask must be worn. Immediately after removal of the suit, a thorough bath with soap and water (preferably hot) must be taken. If any skin areas have come in contact with mustard, if even a very small drop of mustard gets into the eye, or if the vapor of mustard has been inhaled, it is imperative that complete first-aid measures be given within 20 to 30 minutes after exposure. First-aid instructions are given in TM 9-850 and FM 21-40:

(2) Garments exposed to mustard will be decontaminated by hanging in the open air, preferably in sunlight for several days. They may also be cleaned by steaming for two hours. If the impermeable clothing has been contaminated with liquid mustard, steaming for six to eight hours will be required. Various kinds of steaming devices can be improvised from materials available in the field.

b. Procedure.

(1) Commence by freeing materiel of dirt through the use of sticks, rags, etc., which must be burned or buried immediately after this operation.

(2) If the surface of the materiel is coated with grease or heavy oil, this grease or oil should be removed before decontamination is begun. SOLVENT, dry-cleaning, or other available solvents for oil should be used with rags attached to ends of sticks.

(3) Decontaminate the painted surfaces of the materiel by mixing one part AGENT, decontaminating (chloride of lime), with one part water. This solution should be swabbed over all surfaces. Wash off with water, dry, and oil all surfaces.

(4) All unpainted metal parts and instruments exposed to mustard or lewisite must be decontaminated with AGENT, decontaminating, non-corrosive, mixed one part solid to fifteen parts solvent (ACETYLENE TETRACHLORIDE). If this is not available, use warm water and soap. Bleaching solution must not be used, because of its corrosive action. Instrument lenses may be cleaned only with PAPER, lens, tissue, using a small amount of ALCOHOL, ethyl. Coat all metal surfaces lightly with engine oil.

(5) In the event AGENT, decontaminating (chloride of lime), is not available, materiel may be temporarily cleaned with large volumes of hot water. However, mustard lying in joints or in leather or canvas webbing is not removed by this procedure and will remain a constant source of

3-INCH SEACOAST GUN MATERIEL

danger until the materiel can be properly decontaminated. All mustard washed from materiel in this manner lies unchanged on the ground, necessitating that the contaminated area be plainly marked with warning signs before abandonment.

(6) The cleaning or decontaminating of materials contaminated with lewisite will wash arsenic compounds into the soil, poisoning any water supplies in the locality for either man or animals.

(7) Leather or canvas webbing that has been contaminated should be scrubbed thoroughly with bleaching solution. In the event this treatment is insufficient, it may be necessary to burn or bury such material.

(8) Detailed information on decontamination is contained in FM 21-40, and TC 38, 1941, Decontamination.

Chapter 8

OPERATION UNDER UNUSUAL CONDITIONS

Paragraph

Operation without battery commander's station 75

75. OPERATION WITHOUT BATTERY COMMANDER'S STATION.

a. Should the battery commander's station be shelled or damaged so as to render it unserviceable, and thereby create an unusual condition, deflection may still be ascertained by the battery commander and gun pointer. The gun pointer will continue to track the moving target as before, using the traversing handwheel, until the command "Take" is given. At this command, he immediately discontinues tracking with the traversing handwheel, and takes up tracking using the deflection knob. Also at the command "Take," the battery commander measures time with a stop watch until he gives the second command "Take," at which time the gun pointer will stop tracking with the deflection knob. A reading is taken on the deflection scale and a setting is made the same distance away on the other side of the central mark on the deflection scale. On the M1902MI gun, for example, the reading may be taken as 2.40 degrees (fig. 63). A setting will then be made of 3.60 degrees as the deflection, then the regular order of firing is resumed. The deflection setting of 3.60 degrees, as mentioned above, allows the sight to be trained directly on the target and the gun to shoot ahead of the target. The time measured by the stop watch is the amount of time the target will take to meet the shell at a predetermined point after it has been fired from the gun.

b. The range setting will be established from the last order given by the battery commander station. Any variation from this setting thereafter can be determined by observation.

3-INCH SEACOAST GUN MATERIEL

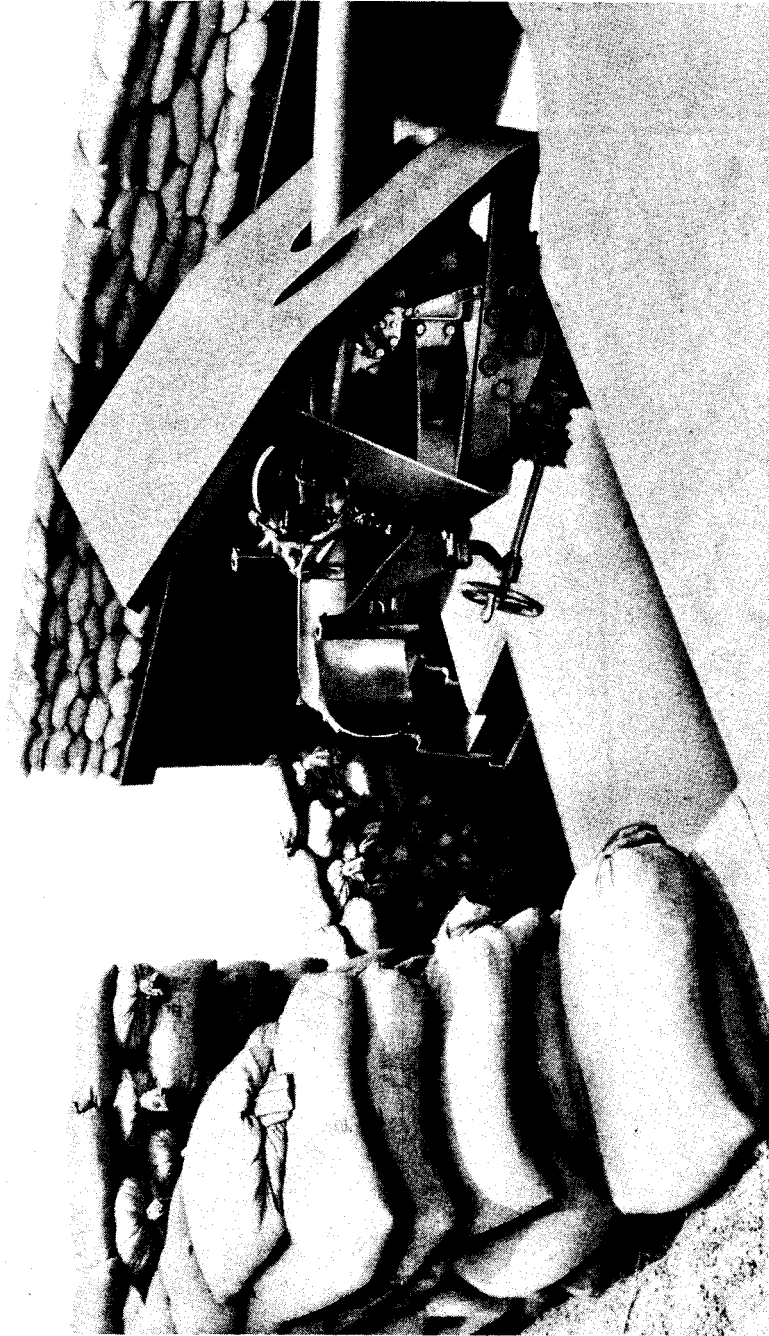

RA PD 33482

Figure 62—Method of Revetment

OPERATION UNDER UNUSUAL CONDITIONS

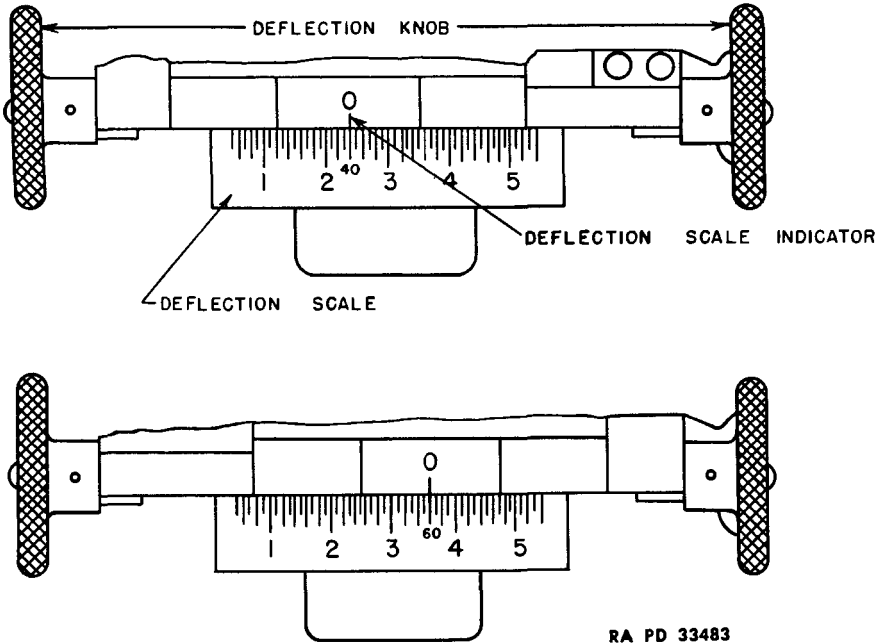

RA PD 33483

Figure 63—Making Deflection Settings

3-INCH SEACOAST GUN MATERIEL

Chapter 9

REFERENCES

	Paragraph
Standard nomenclature lists	76
Explanatory publications	77
Firing tables	78

76. STANDARD NOMENCLATURE LISTS.

- a. Guns, 3-in. (15-pdr.), M1902MI and M1903 SNL E-2
 - b. Carriages, barbette, 3-in. (15-pdr.), M1902, M1903 SNL E-15
 - c. Ammunition, fixed, including subcaliber ammunition, for harbor defense, heavy field and railway artillery SNL P-6
 - d. Cleaning, preserving and lubrication materials, recoil fluids, special oils, and similar items of issue SNL K-1
 - e. Firing tables and trajectory charts SNL F-69
- Current Standard Nomenclature Lists are as tabulated here.

An up-to-date list of SNL'S is maintained as the "Ordnance Publications for Supply Index" OPSI

77. EXPLANATORY PUBLICATIONS.

- a. Cleaning, preserving, and lubricating and welding materials and similar items issued by the Ordnance Department TM 9-850
- b. Ammunition, general TM 9-1900
- c. Small-arms ammunition TM 9-1990
- d. Defense against chemical attack FM 21-40
- e. Ordnance field service in time of peace AR 45-30
- f. Range regulations for firing ammunition for training and target practice AR 750-10
- g. 3-in. rapid-fire gun (barbette carriage) FM 4-90
- h. Fire control and position finding FM 4-15
- i. Antitank mine platoon, antitank company, infantry rifle regiment TC 38

REFERENCES

78. FIRING TABLES.

- a. Gun, 3-in. (15-pdr.), M1902MI, mounted on carriage, barbette, M1902.—
- SHELL, fixed, H.E., M42A1, w/FUZE, P.D. M48,
3-in. (15-pdr.) gun, M1902MI FT 3-Q-1
- SHELL, fixed, H.E., M42, w/FUZE, P.D., M48,
3-in. (15-pdr.) gun, M1902MI FT 3-Q-1
- SHELL, fixed, H.E., M1915, 3-in. (15-pdr.) gun,
M1902MI FT 3-M-2
- PROJECTILE, fixed, target practice, Mk. VII,
3-in. (15-pdr.) gun, M1902MI FT 3-M-2
- PROJECTILE, fixed, target practice, Mk. VIIAI,
3-in. (15-pdr.) gun, M1902MI FT 3-M-2
- SHOT, fixed, target practice, 3-in. (15-pdr.) gun,
M1902MI FT 3-M-2
- b. Gun, 3-in. (15-pdr.), M1903 mounted on carriage, barbette, M1903.—
- SHELL, fixed, H.E., M42A1, w/FUZE, P.D., M48,
3-in. (15-pdr.) gun, M1903 FT 3-Q-1
- SHELL, fixed, H.E., M42, w/FUZE, P.D., M48,
3-in. (15-pdr.) gun, M1903 FT 3-Q-1
- SHELL, fixed, H.E., M1915, 3-in. (15-pdr.) gun,
M1903 FT 3-M-2
- PROJECTILE, fixed, target practice, Mk. VII,
3-in. (15-pdr.) gun, M1903 FT 3-M-2
- PROJECTILE, fixed, target practice, Mk. VIIAI,
3-in. (15-pdr.) gun, M1903 FT 3-M-2
- SHOT, fixed, target practice, 3-in. (15-pdr.) gun,
M1903 FT 3-M-2
- SHELL, fixed, H.E., Mk. I, 3-in. (15-pdr.) gun,
M1903 FT 3-P-1
- c. Cartridge, subcaliber (3-in. gun, M1902MI or
M1903).—
- CARTRIDGE, subcaliber, cal. .30, M1925 FT 0.30-E-4

THE ARMY LIBRARY

118
WASHINGTON, D.C.

3-INCH SEACOAST GUN MATERIEL

INDEX

A	Page No.	Page No.
Accessories		
for special uses		
artillery gun book	99	
brush, slush	99	
paulin, covering	99	
scraper (corrosion and rust proofing compound)	99	
sponge and staff (sponge and bore of the gun)	99	
tompson, front sight bracket	99	
wrenches	101	
general description of	98	
Action of the gun when fired	23	
Active season, preparation for	62	
Adjustment (See also Inspection and adjustment)		
subcaliber cartridge	105	
Ammunition	73-96	
authorized rounds	77-81	
general description of	77-78	
tables		
gun M1902MI	78-79	
gun M1903	80-81	
care, handling, and preservation	76-77	
classification of	73-74	
exposed to gas, cleaning of	112	
field report of accidents	96	
firing tables	119	
fuzes	93-94	
general description of	74	
gun M1902MI	81-86	
general description	81	
gun M1903	86-93	
general description	86	
identification	74	
marking, changes in (table)	75-76	
nomenclature, standard, use of	73	
packing data	94-96	
marking	96	
preparation of for firing	81	
subcaliber	96	
Arming fuzes	93	
Artillery gun book	99	
Authorized rounds (See under Ammunition)		
B		
Ball bearings	17	
Battery commander's station, operation without	115	
Bearings, preparing for inactive season	62	
Blank ammunition		
gun M1902MI	79	
gun M1903	80	
Book, artillery gun	99	
Bore		
data		
gun M1902MI	5-6	
gun M1903	5-6	
lubrication		
gun M1902MI	59	
gun M1903	61	
preparation for inactive season	62	
subcaliber cartridge, lubrication of	108	
Boresafe fuzes	93	
Breech, opening and closing	33	
Breech and firing mechanism		
lubrication intervals		
gun M1902MI	59	
gun M1903	61	
preparation for inactive season	62	
Breech mechanism		
cleaning	48	
assembly after	48	
data	6	
description		
function	9	
principal parts	9-12	
disassembly of (for cleaning)	45-48	
inspection and adjustment	66	
malfunction and correction	40	
Breechblock		
data	6	
description	9	
Breechblock carrier, use of	9-12	
Breechblock latch, operation of	12	
Brush, slush, use of	99	
Bushings, pivot yoke	17	
C		
Care and maintenance of bore and barrel	108	
Care and preservation		
additional lubrication and service instructions		
gun M1902MI	59	
gun M1903	61	
after firing	44	
bore cleaned and lubricated	44	
breech mechanism	44	

INDEX

C—Cont'd	Page No.	Page No.
Care and preservation—Cont'd		carriage M1903 19-23
after firing—Cont'd		Cradle trunnions, M1903 carriage . . . 17
firing mechanism 45		D
ammunition 76-77		Data
firing mechanism 44		ammunition, packing
lubrication, proper 42-43		general information on 94
materiel not in use 43		marking 96
Carriages		carriages 6-7
care and preservation of 42-43		guns 5-6
characteristics 4-5		sighting and fire control instru-
data on 6-7		ments 8
description		subcaliber equipment 7-8
M1902MI		Deflection setting 115
electrical equipment 29		Description
lighting circuit 29		accessories for special uses 98-101
elevation mechanism 25		ammunition
elevating bracket 25		gun M1902MI 81
shoulder rest 25		gun M1903 86
range indicator 28		breech mechanism 9-12
recoil and counterrecoil		carriage M1902
mechanism 19		electrical equipment 29
traversing mechanism 25-28		elevation mechanism 25
M1903		general description 17
electrical equipment 29-32		range indicator 28
elevating mechanism 25		recoil and counterrecoil
range indicator (drum) 28		mechanism 19
recoil and counterrecoil		traversing mechanism 25-28
mechanism 19-23		carriage M1903
inspection and adjustment 65		electrical equipment 29-32
lubrication 41-42		elevation mechanism 25
malfunction and correction of 41		general description 17
service of during inactivity 63		range indicator 28
Cartridges, drill		recoil and counterrecoil
gun M1902MI 85-86		mechanism 19-23
gun M1903 90, 93		traversing mechanism 28
subcaliber 103		firing mechanism 12-14
Caution during firing of gun 36-38		fuzes 93
Characteristics of carriages 4-5		routine service of gun and
Chemicals, liquid, removal of 113-114		carriage 42-43
Classification of ammunition 73-74		Differences between models
Cleaning		inherent 5
breech mechanism 48		visible 4-5
materials 63-64		Disassembly (and cleaning of)
materiel affected by gas 112		breech mechanism for clean-
rifle barrel (subcaliber cartridge) 108		ing 45-48
Closing breech 33		subcaliber cartridge 105
Cocking lever (firing case) 16		Drill cartridges (See Cartridges,
Construction of guns, data on 5		drill)
Correction (See Malfunction and		E
correction)		Electric lighting circuit, data on 7
Counterrecoil mechanism		Electrical equipment
carriage M1902 19		carriage M1902 29

3-INCH SEACOAST GUN MATERIEL

E—Cont'd	Page No.	Page No.	
Electrical Equipment—Cont'd			
carriage M1903	29-32	data on	6
inspection and adjustment	68	disassembly for cleaning	49
Elevating and depressing gun	33	fuze	
Elevating and range disk racks and pinions, traversing rack and traversing bevel pinions, lubrication	59	fuze combination, 21-sec.	
Elevating gear case		fuze, P.D. M48	93-94
lubrication	59	M1907M	94
preparation for inactive season	63	inspection and adjustment	66
Elevating screw housing, lubrication of	63	malfunctions and corrections	40
Elevation, maximum		percussion type, description	12-14
carriages	6	Firing pin	
guns	4	description	14
Elevation mechanism		protrusion of	38
data	6	Firing spring and follower	14
description	25	Fixed projectile, target practice	
inspection and adjustment	67	gun M1902MI	82
Excessive lubrication and wear (guns and carriages)	50	Fixed shells (See Shells, fixed)	
Explosives, precautions for	76	Fixed shot (See Shot, fixed, target practice)	
Extractor (breech mechanism)	12	Friction band (carriage M1903)	17
Extractor hinge pin (breech mechanism)	12	Fuzes	
Extractor spring, use of	105	arming	93
F		boresafe	93
Field report of ammunition		fuze, B.D. Mk. V	94
accidents	96	fuze, combination, 21-sec., M1907M	94
Fire control equipment	8	fuze, P.D. M48	
Fire(-ing)		description	93-94
ammunition, tables	119	preparation for firing	94
failure to	40, 41	general description	93
guns	33	G	
points to be observed before	33-36	Gear cases, lubrication of	51
lubrication	33	Gun book, artillery	99
preparation for measuring recoil	36	Gun bore (See Bore)	
points to be observed during	36-38	Guns	
caution		ammunition for	
if gun fails to fire	36	gun M1902MI	81-86
lanyard	36	gun M1903	86-93
safety precautions	36	care and preservation of	42-66
protrusion of the firing pin	38	characteristics	4-5
gun M1902MI	38	data	5-6
gun M1903	38	description	9-15
recoil, to measure the	38	breech mechanism	9-12
preparation of ammunition for	81	firing mechanism	12-14
recoil of gun	23	general	9
subcaliber cartridge	106	inspection and adjustment	65
subcaliber equipment	105	lubrication and service	
Firing case	14	instructions	
Firing mechanism		gun M1902MI	59
cleaning and oiling	50	gun M1903	61
		malfunction and correction of	40-41
		maximum elevation attainable of	4
		mounted on carriages	4

INDEX

G—Cont'd	Page No.		Page No.
Guns—Cont'd		additional	
paulin (covering), use of	99	gun and carriage M1902	59
recoil action of	23	gun and carriage M1903	61
service of during inactivity	63		
spare parts for		M	
gun M1902MI	97-98	Malfunction and correction	
gun M1903	98	ammunition	96
subcaliber cartridge, installation		carriage	41
of	105	gun	40-41
H		Mark or model, ammunition	74
Hinge pin (breech mechanism)	12	Marking ammunition, changes in	
I		(table)	75-76
Identification of:		Markings, weight zone	76
ammunition	74	Materials, servicing	
lubrication points	51	cleaning	63-64
Inactive season		lubricants	63
preparation for	62-63	preserving	64
servicing guns and carriages		recoil oil	64
during	63	Materiel affected by gas	
Inspection and adjustment		cleaning	112
breech mechanism	66	decontamination	113-114
charts	70-71	protective measures	112
electrical equipment	68	Maximum breech pressure (sub-	
elevating mechanism	67	caliber equipment)	7
firing mechanism	66	Maximum elevation	
gun	65	carriages	6
mount	68	guns	4
purpose of	65	Mechanism, recoil and counter-	
recoil and counterrecoil		recoil	19-23
mechanism	67-68	Metal parts and surfaces	
sight elevating mechanism	68-69	cleaning exposed	112
traversing mechanism	67	painting	110-111
Instructions, lubrication (See <i>under</i>		Minimum elevation (carriages)	6
Guns and Carriages)		Models, difference between	4-5
Intervals for lubrication		Mount, inspection and adjustment	68
gun M1902MI	59	Muzzle velocity, maximum	
gun M1903	61	guns	6
K		subcaliber equipment	7
Kit, subcaliber and drill cartridge	103	N	
L		Nomenclature, standard, use of for	
Liquid chemicals, removal of	113-114	ammunition	73
Loading the gun	33	O	
Lot number, ammunition	74	Oil screw plugs, cleaning and	
Lubricating devices, painting	111	lubrication	
Lubrication		gun M1902MI	59
breech mechanism	48	gun M1903	61
after firing	44	Oilholes, cleaning and oiling	51
sliding surfaces of	50-51	Open gears, screws, worms, and racks,	
carriage (daily drill)	42-43	preparation for inactive season	63
charts	57-58, 60	Opening the breech	33
firing mechanism, after firing	45	Operating lever and bar (breech	
instructions	50-51	mechanism)	12

3-INCH SEACOAST GUN MATERIEL

O—Cont'd	Page No.	R	Page No.
Operation		Range	
general information on	33	maximum	
inspection of	65	guns	6
instructions		subcaliber equipment	7
elevating, depressing, traversing,		setting under unusual conditions	115
and loading gun	33	Range indicators for carriages	28
firing guns	33	Rate of fire, data on	6
points to be observed before		Receptacles for lubricants	51
lubrication	33	Recoil and counterrecoil mechanism	
recoil, preparation for		description	
measuring	36	carriage M1902	19
points to be observed during		carriage M1903	19-23
cautions	36-38	inspection and adjustment	67-68
protrusion of firing pin	38	Recoil (mechanism)	
recoil, measuring	38	action of	23
opening and closing breech	33	cylinder, use of	17
subcaliber cartridge	106	data on	7
under unusual conditions	115	excessive, cause and correction of	41
		fluid	59, 61
P		measuring after firing	38
Packing, ammunition, data on	94-96	oil	64
Painted surfaces, preparation for		slides	
inactive season	62	lubrication	61
Painting		preparation for inactive season	63
ammunition	74-75	Records	
general information on	109-110	artillery gun book	99
lubricating devices	111	lubrication servicing	51
metal surfaces	110-111	Recuperating mechanism	7
preparing for	110	Rifling, data on	6
removing	111	Routine service of the gun and	
Paulin, use of for covering gun	99	carriage	42-43
Percussion type of firing			
mechanism	12-14	S	
Pinions, lubrication	59	Safety precautions during firing	36-38
Pivot yoke thrust bearing		Scraper, use of	99
lubrication	59, 61	Sear and spring (firing mechanism)	16
preparation for inactive season	63	Service of gun and carriage during	
Power of guns, data on	6	inactivity	63
Practice with subcaliber ammunition	96	Servicing material	
Precautions for explosives	77	cleaning material	63-64
Preserving materials	64	lubricants	57-58, 60
Primers for painting	110	preserving material	64
Projectile, fixed, target practice		recoil oil	64
gun M1902MI	82	Shells, fixed	
Projectiles, target practice		gun M1902MI	82
gun M1902MI	85	gun M1903	86-89
gun M1903	89-90	Shot, fixed, target practice	
Protective measures for materiel		gun M1902MI	85
affected by gas	112	gun M1903	90
Protrusion of firing pin		Sight elevating mechanism	
gun M1902MI	38	inspection and adjustment of	68-69
malfunction and correction	41		
gun M1903	38		

INDEX

S—Cont'd		Page No.			Page No.
Sight elevating mechanism—Cont'd			gun M1903		
preparation for inactive season	63		service	80	
Sighting and fire control instruments,			subcaliber	81	
data on	8		target practice	80	
Sliding surfaces (breech			blank	80	
mechanism)	50-51		drill	80-81	
Slush, brush	99		marking, changes in	75-76	
Spare parts, description			Target practice projectiles (See		
gun M1902MI	97-98		Projectiles, target practice)		
gun M1903	98		Tompion, front sight bracket	99	
Sponge and staff, use of	99		Traversing and elevating gear cases,		
Standard nomenclature, use of for			lubrication of	61	
ammunition	73		Traversing locking device	17	
Storage batteries	4		Traversing mechanism		
Stuffing box, use of	19		data on	6	
Subcaliber ammunition	96		description		
Subcaliber equipment			carriage M1902	25-28	
care and maintenance of	108		carriage M1903	28	
data on	7		inspection and adjustment	67	
installation of cartridge in bore of			Traversing rack, range drum rack		
gun	105		and pinion, lubrication	61	
materiel			Traversing the gun	33	
cartridge, drill	103		Trigger shaft (breech mechanism),		
cartridge, subcaliber	103		description of	12	
extractor spring	105		Trunnion bearings	17	
subcaliber and drill cartridge kit	103				
operation of cartridge	106				
purpose of	103				
T					
Tables, ammunition					
firing	119				
gun M1902MI					
blank	79				
drill	79				
service	78				
subcaliber	79				
target practice	78-79				
U					
			Unusual conditions, operation		
			under	115-117	
W					
			Weight		
			ammunition, packing	96	
			carriages	6	
			guns	5	
			3" subcaliber cartridge	7	
			Weight zone markings	76	
			Wooden box, ammunition packed in	76	
			Wrenches for special use	101	

[A.G. 062.11 (7-16-42)
O.O. 461/19113 O.O. (9-15-42)]

BY ORDER OF THE SECRETARY OF WAR:

G. C. MARSHALL,
Chief of Staff.

Official:

J. A. ULIO,
Major General,
The Adjutant General.

Distribution: IR 4(5); R 9(2); IBn 4(3), 9(1); IC 4(6), 9(4).
(For explanation of symbols, see FM 21-6)

TECHNICAL MANUAL

3-INCH SEACOAST GUN MATÉRIEL

CHANGES
No. 1

WAR DEPARTMENT,
WASHINGTON 25, D. C., 30 June 1943.

TM 9-421, 10 October 1942, is changed as follows:

3. Data.

* * * * *

b. Carriages, *barbette*, 3-inch (15-pdr.)

Type		M1902	M1903
Total weight	----- pounds	3, 310	4, 075
		*	*

4. 3-inch guns M1902M1 and M1903.—These guns are * * * into the bushing. The breech bushing contains interrupted threads for the breechblock.

5. Breech mechanism.

* * * * *

b. *Principal parts.*

* * * * *

(2) *Breechblock carrier.*—The breechblock carrier * * * the trigger shaft.

NOTE.—Several of the breechlock carriers on the 3-inch gun M1902M1 are cracked. Investigation has proved that it is safe to use this matériel with the cracked breechblock carriers.

* * * * *

[A. G. 300.7 (22 Apr 43).] (C 1, 30 Jun 43.)

11. Range indicators.—a. *Range disk for the M1902 carriage.*—This disk, attached to the left side of the carriage, is graduated in mils of elevation. On some of the disks, not yet modified to mils, the graduations are in yards of range. The old disks have two sets of range figures. The outside set is for long pointed projectiles and the inside set for short pointed projectiles. A pinion on * * * for small adjustments (fig. 16).

b. *Range drum for the M1903 carriage.*—This drum, attached to the left side of the carriage, is graduated to ranges in mils. On a few of the range drums not yet modified to mils, the graduations are in yards of range. Two sets of graduations are marked on these old range drums, the left for long pointed projectiles and the right for short pointed projectiles. A pinion on * * * rack and pinion (fig. 17).

[A. G. 300.7 (22 Apr 43).] (C 1, 30 Jun 43.)

19. General.

* * * * *

c. All parts provided * * * firing is started. To fill the cylinder on the M1902 carriage (fig. 26) remove the plug in the filling hole and bring the gun to **maximum** depression. To fill the cylinder on the M1903 carriage (fig. 28) remove the plug in the filling hole and bring the gun to **maximum** elevation. The recoil cylinder * * * tighten drain plug.

* * * * *

20. **After firing.**—*a. Bore.*—After firing, and while the gun is still warm, the bore should be cleaned. Swab the bore (fig. 31) with a solution of one-half pound of soda ash to each gallon of water. This solution should * * * or cleaning cloths. Oil the bore with oil, engine, SAE 10 (for temperature below 32° F.), or SAE 30 (for temperature above 32° F.).

b. Breech mechanism.—The breech mechanism should be disassembled, cleaned, and oiled **daily** and immediately after firing. This is especially * * * or oil channels.

* * * * *

[A. G. 300.7 (22 Apr 43).] (C 1, 30 Jun 43.)

22. Disassembly and cleaning of the firing mechanism.

* * * * *

b. Cleaning and oiling.—Clean all bright * * * using clean rags. Lubricate with a thin film of engine oil. **Clean other surfaces** thoroughly with solvent, dry-cleaning, and apply sparingly oil, engine, SAE 30 above +32° F.; SAE 10 at +32° F. to 0° F.

* * * * *

[A. G. 300.7 (22 Apr 43).] (C 1, 30 Jun 43.)

NOTES (page 59)

Additional Lubrication and Service Instructions on Individual Units and Parts
COLD WEATHER: For lubrication and service below 0° F., refer to TM 9-850

* * * * *

4. *Elevating gear case.*—Monthly, check level and add oil, if necessary. Every 6 months, drain flush, and refill. Fill case to level plug opening with oil, engine, seasonal grade.

* * * * *

6. *Gun bore.*—**Daily** and after firing, clean and coat with oil, engine, seasonal grade.

* * * * *

[A. G. 300.7 (22 Apr 43).] (C 1, 30 Jun 43.)

NOTES (page 61)

Additional Lubrication and Service Instructions on Individual Units and Parts
COLD WEATHER: For lubrication and service below 0° F., refer to TM 9-850

* * * * *

6. *Breech and firing mechanism.*—Daily, and before * * * engine, seasonal grade. To insure easy breech operation and to avoid misfiring in cold weather, clean with solvent, dry-cleaning, dry and lubricate with oil, lubricating, preservative, light. To clean firing mechanism, remove and operate pin in solvent, dry-cleaning.

7. *Gun bore.*—Daily and after firing, clean and coat with oil, engine, seasonal grade.

* * * * *

[A. G. 300.7 (22 Apr 43).] (C 1, 30 Jun 43.)

29. Gun.

*Inspection**Adjustment*

Note condition of bore. Look Clean and flush. Wipe dry
for copper deposits and rust. and lubricate.
Note lubrication of bore.

[A. G. 300.7 (22 Apr 43).] (C 1, 30 Jun 43.)

Chapter 8, Operation under unusual conditions, is rescinded.

[A. G. 300.7 (22 Apr 43).] (C 1, 30 Jun 43.)

Figure 62, page 116, is rescinded.

[A. G. 300.7 (22 Apr 43).] (C 1, 30 Jun 43.)

Figure 63, page 117, is rescinded.

[A. G. 300.7 (22 Apr 43).] (C 1, 30 Jun 43.)

BY ORDER OF THE SECRETARY OF WAR:

G. C. MARSHALL,
Chief of Staff.

OFFICIAL:

J. A. ULIO,
Major General,
The Adjutant General.