

# **Certain Sortation Systems, Parts Thereof, and Products Containing Same**

Investigation No. 337-TA-460

Publication 3588

March 2003

**U.S. International Trade Commission**

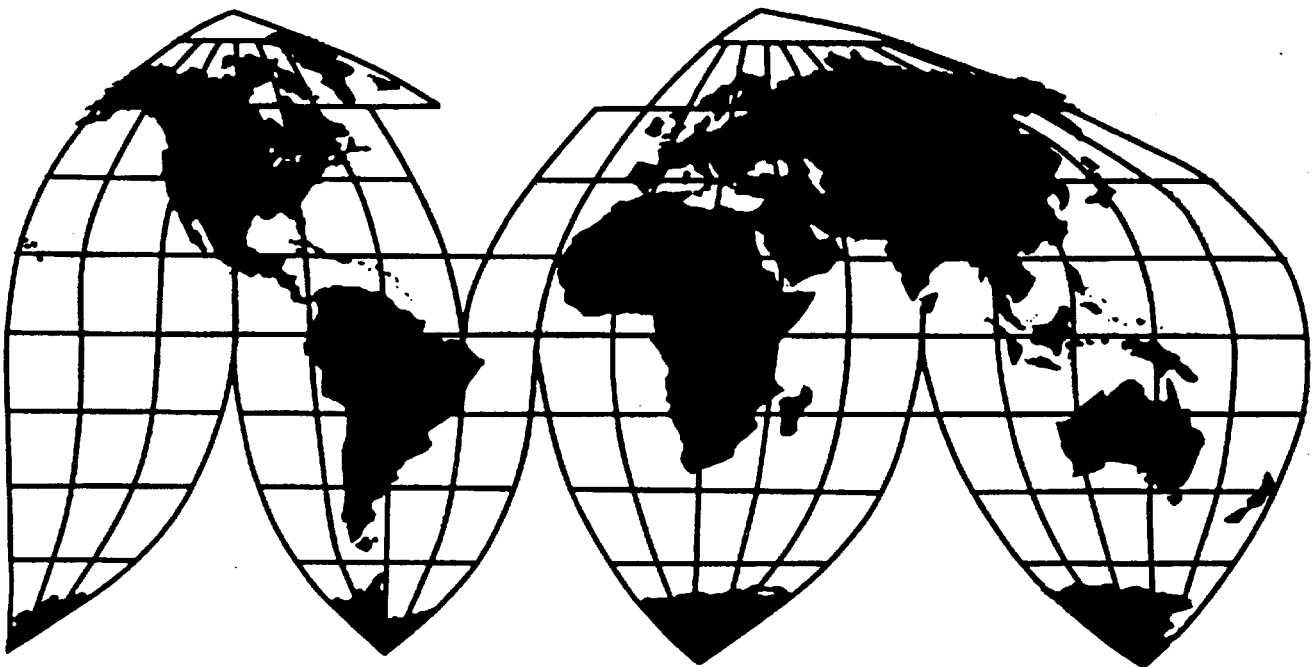

Washington, DC 20436

# **U.S. International Trade Commission**

## **COMMISSIONERS**

**Deanna Tanner Okun, Chairman**  
**Jennifer A. Hillman, Vice Chairman**  
**Marcia E. Miller**  
**Stephen Koplan**

**Address all communications to  
Secretary to the Commission  
United States International Trade Commission  
Washington, DC 20436**

# **U.S. International Trade Commission**

Washington, DC 20436

*www.usitc.gov*

## **Certain Sortation Systems, Parts Thereof, and Products Containing Same**

Investigation No. 337-TA-460



**Publication 3588**

**March 2003**

UNITED STATES INTERNATIONAL TRADE COMMISSION  
Washington, DC 20436

In the Matter of

CERTAIN SORTATION SYSTEMS,  
PARTS THEREOF, AND PRODUCTS  
CONTAINING SAME

Inv. No. 337-TA-460

03 JAN 27 P 3:01

RECEIVED  
OFFICE OF THE SECRETARY  
U.S. INTERNATIONAL TRADE COMMISSION

0011108

NOTICE OF VIOLATION OF SECTION 337 OF THE TARIFF ACT OF 1930  
AND ISSUANCE OF LIMITED EXCLUSION ORDER

AGENCY: U.S. International Trade Commission.

ACTION: Notice.

SUMMARY: Notice is hereby given that the U.S. International Trade Commission has determined that there is a violation of section 337 of the Tariff Act of 1930 in the above-captioned investigation and issued a limited exclusion order.

FOR FURTHER INFORMATION CONTACT: Michael K. Haldenstein, Esq., Office of the General Counsel, U.S. International Trade Commission, telephone 202-205-3041. Copies of the limited exclusion order, the public version of the Commission's opinion, and all other nonconfidential documents filed in connection with this investigation are or will be available for inspection during official business hours (8:45 a.m. to 5:15 p.m.) in the Office of the Secretary, U.S. International Trade Commission, 500 E Street S.W., Washington, D.C. 20436, telephone 202-205-2000.

General information concerning the Commission may also be obtained by accessing its Internet server (<http://www.usitc.gov>). Hearing-impaired persons are advised that information on the matter can be obtained by contacting the Commission's TDD terminal on 202-205-1810. The public record for this investigation may be viewed on the Commission's electronic docket (EDIS-ON-LINE) at <http://dockets.usitc.gov/eol/public>.

**SUPPLEMENTARY INFORMATION:** The Commission voted to institute this investigation on July 19, 2001, based upon a complaint filed on June 25, 2001, by Rapistan Systems Advertising Corp. and Siemens Dematic Corp., both of Grand Rapids, Michigan. 66 Fed. Reg. 38741 (July 25, 2001). Named as respondents were Vanderlande Industries Nederland BV of the Netherlands, and Vanderlande Industries of Atlanta, Georgia (collectively referred to as "Vanderlande"). Vanderlande Industries Nederland BV of the Netherlands designs and manufactures the accused sortation systems, and Vanderlande Industries of Atlanta imports, sells, and installs the accused sortation systems.

Complainants alleged that respondents had violated section 337 by importing into the United States, selling for importation, and selling within the United States after importation certain sortation systems, or components thereof, covered by independent claims 1, 13, 23, 30, and 42 and dependent claims 2, 3, 4, 8, 9, 17, 18, 20, 22, 24, 27, 29, 33, 35, 36, 37, 39, 43, 45, 46, 47, and 49 of U.S. Patent No. 5,127, 510 (“the ‘510 patent”), owned by Rapistan Systems and exclusively licensed to Siemens Dematic. On April 5, 2002, complainants filed an unopposed motion asking for the termination of the investigation with respect to claims 2, 3, 8, 9, 18, 24, 36, 37, 29, 46, 47, and 49. On May 16, 2002, the presiding administrative law judge (ALJ) granted the motion in an ID (Order No. 32) and the Commission determined not to review that ID. The claims of the ‘510 patent at issue were therefore claims 1, 4, 13, 17, 20, 22, 23, 27, 29, 30, 33, 35, 42, 43, and 45. The complaint further alleged that an industry in the United States exists, as required by subsection (a)(2) of section 337.

An evidentiary hearing was held on June 4-17, 2002. On October 22, 2002, the ALJ issued his final initial determination (ID), in which he determined that respondents’ sortation systems, and parts thereof, infringe claims 1 and 4 of the ‘510 patent, and that the ‘510 patent is valid and enforceable. Based upon these findings and the finding that there is a domestic industry, he found a violation of section 337.

The ALJ recommended issuance of a limited exclusion order barring importation of the respondents’ accused Mark 2 Posisorter sortation system and its parts and components. He recommended exempting spare parts destined for UPS’s Hub 2000 facility in Louisville, Kentucky from the scope of the limited exclusion order. He also recommended a bond during the Presidential review period in the amount of 100 percent of the entered value of the infringing products.

On November 4, 2002, Vanderlande and the Commission investigative attorney (IA) petitioned for review of portions of the ALJ’s final ID, and Rapistan submitted a contingent petition for review asking that the Commission review certain issues if it decided to review the ID. On November 12, 2002, Vanderlande, Rapistan, and the IA filed reply submissions.

The Commission determined to review the ID on the following issues: (1) the ID’s construction of the claim limitation “contiguous, generally planar surfaces sloping downward from an upper extent of said diverting surface laterally inward and longitudinally forward or rearward” in independent claim 30, and dependent claims 33, and 35, and the infringement findings related to this claim element; and (2) the ID’s findings regarding the affirmative defense of equitable estoppel.

Rapistan, Vanderlande, and the IA filed submissions on December 23, 2002, and reply submissions on December 30, 2002, addressing the two issues under review and remedy, the public interest, and bonding.

The Commission reviewed these issues and the parties’ submissions and determined: (1) to modify the ALJ’s construction of the limitation in claim 30 quoted above, and to find that the accused product does not meet this limitation; (2) that the elements of equitable estoppel have not been established.

The Commission also determined that the appropriate remedy consists of a limited exclusion order prohibiting the importation of the infringing sortation systems, and shoes and slats thereof, manufactured abroad by Vanderlande Industries. The Commission determined to include an exemption in the limited exclusion order for importations of spare parts for United Parcel Service’s Hub 2000 facility in Louisville, Kentucky. The Commission further determined that the statutory public interest

factors do not preclude the issuance of such relief. Finally, the Commission determined that during the Presidential review period importation should be permitted pursuant to a bond requirement in the amount of 100 percent of the entered value of the infringing products.

This action is taken under the authority of section 337 of the Tariff Act of 1930 (19 U.S.C. § 1337) and section 210.50 of the Commission's Rules of Practice and Procedure (19 C.F.R. § 210.50).  
By order of the Commission.



Marilyn R. Abbott  
Secretary to the Commission

Issued: January 27, 2003

**UNITED STATES INTERNATIONAL TRADE COMMISSION**  
**Washington, D.C.**

**In the Matter of**

**CERTAIN SORTATION SYSTEMS,  
PARTS THEREOF, AND PRODUCTS  
CONTAINING SAME**

**Inv. No. 337-TA-460**

**LIMITED EXCLUSION ORDER**

The Commission has determined that there is a violation of section 337 of the Tariff Act of 1930, as amended, 19 U.S.C. § 1337, in the unlawful importation and sale by Respondents Vanderlande Industries Nederland BV and Vanderlande Industries, Inc. (collectively referred to as "Vanderlande") of sortation systems and parts thereof by reason of infringement of claims 1 and 4 of U.S. Patent No. 5,127,510. Having reviewed the record in this investigation, including the written submissions of the parties, the Commission has made its determination on the issues of remedy, the public interest, and bonding. The Commission has determined that the appropriate form of relief is a limited exclusion order prohibiting the unlicensed entry of infringing sortation systems, and shoes and slats thereof, manufactured by or for Vanderlande. The Commission has determined that an exception to the limited exclusion order is warranted for sortation system parts imported for use as spare parts at the United Parcel Service (UPS) Hub 2000 facility in Louisville, Kentucky.

The Commission has determined that the public interest factors enumerated in 19 U.S.C. § 1337 (d) do not preclude issuance of the limited exclusion order. Finally, the Commission has determined that the bond during the Presidential review period shall be in the amount of 100 percent of the entered value of any imported sortation systems and parts thereof (except exempted parts).

Accordingly, the Commission hereby **ORDERS THAT**:

1. Sortation systems, and shoes and slats thereof, covered by claims 1 or 4 of U.S. Patent No. 5,127,510 that are manufactured abroad and/or imported by or on behalf of Vanderlande, or any of its affiliated companies, parents, subsidiaries, or other related business entities, or their successors or assigns, are excluded from entry for consumption into the United States, entry for consumption from a foreign trade zone, or withdrawal from a warehouse for consumption, for the remaining term of the patent, *i.e.*, until October 31, 2010, except under license of the patent owner, as provided by law, or as exempted below. This exclusion order does not apply to

sortation system parts imported for use as spare parts at the UPS Hub 2000 facility in Louisville, Kentucky. Persons seeking to import sortation system parts pursuant to this exemption are directed to utilize the certification procedure of paragraph 3 of this Order.

2. Sortation systems, and shoes and slats thereof, that are excluded by paragraph 1 of this Order are entitled to entry for consumption into the United States, entry for consumption from a foreign trade zone, or withdrawal from a warehouse for consumption, under bond in the amount of 100 percent of entered value pursuant to subsection (j) of section 337 of the Tariff Act of 1930, as amended, 19 U.S.C. § 1337(j), from the day after this Order is received by the President until such time as the President notifies the Commission that he approves or disapproves this action but, in any event, not later than sixty (60) days after the date of receipt of this action.

3. Pursuant to procedures to be specified by the U.S. Customs Service, as the Customs Service deems necessary, persons seeking to import sortation system parts as spare parts for the UPS Hub 2000 facility in Louisville, Kentucky shall certify that they are familiar with the terms of this Order, that they have made appropriate inquiry, and thereupon state that, to the best of their knowledge and belief, the products being imported are not excluded from entry under paragraph 1 of this Order. At its discretion, the Customs Service may require persons who have provided the certification described in this paragraph to furnish such records or analyses as are necessary to substantiate the certification.

4. In accordance with 19 U.S.C. § 1337(l), the provisions of this Order shall not apply to sortation systems, and shoes and slats thereof, that are imported by and for the use of the United States, imported for, and to be used for, the United States with the authorization or consent of the Government.

5. The Commission may modify this Order in accordance with the procedures described in section 210.76 of the Commission's Rules of Practice and Procedure, 19 C.F.R. § 210.76.

6. The Secretary shall serve copies of this Order upon each party of record in this investigation and upon the Department of Health and Human Services, the Department of Justice, the Federal Trade Commission, and the U.S. Customs Service.

7. Notice of this Order shall be published in the *Federal Register*.

By Order of the Commission.



Marilyn R. Abbott  
Secretary to the Commission

Issued: January 27, 2003



**CERTIFICATE OF SERVICE**

I, Marilyn R. Abbott, hereby certify that the attached NOTICE OF VIOLATION OF SECTION 337 OF THE TARIFF ACT OF 1930 AND ISSUANCE OF LIMITED EXCLUSION ORDER, was served upon David H. Hollander, Commission Investigative Attorney, and the following parties via first class mail and air mail where necessary on January 27, 2003.



Marilyn R. Abbott, Secretary  
U.S. International Trade Commission  
500 E Street, SW - Room 112  
Washington, DC 20436

**ON BEHALF OF COMPLAINANTS RAPISTAN  
SYSTEMS ADVERTISING CORPORATION  
AND SIEMENS DEMATIC CORPORATION:**

V. James Adduci, II, Esq.  
Adduci, Mastriani and Schaumberg, LLP  
1200 Seventh Street, NW  
Fifth Floor  
Washington, DC 20036

Daniel Van Dyke, Esq.  
Van Dyke, Gardner, Linn & Burkhardt, LLP  
2851 Charlevoix Drive S.E.  
Grand Rapids, Michigan 49588-8695

R. Brent Hatcher, Jr., Esq.  
Powell, Goldstein, Frazer & Murphy LLP  
191 Peachtree Street, NE  
Sixteenth Floor  
Atlanta, Georgia 30303

Jerry B. Blackstock, Esq.  
Hunton and Williams  
Bank of American Plaza  
Suite 4100  
600 Peachtree Street, NE  
Atlanta, Georgia 30308-2216

Robert r. Merhige, Jr.  
Hunton and Williams  
Riverfront Plaza, East Tower  
951 East Byrd Street  
Richmond, VA 23219-4074

**ON BEHALF OF VANDERLANDE  
INDUSTRIES NEDERLAND BV AND  
VANDERLANDE INDUSTRIES  
INCORPORATED:**

John M. DiMatteo, Esq.  
Patterson Belknap Webb and Tyler LLP  
1133 Avenue of the Americas  
New York, New York 10036-6710

Cecilia H. Gonzalez, Esq.  
Howrey Simon Arnold and White LLP  
1299 Pennsylvania Avenue, NW  
Washington, DC 20004

UNITED STATES INTERNATIONAL TRADE COMMISSION  
Washington, D.C.

In the Matter of

CERTAIN SORTATION SYSTEMS,  
PARTS THEREOF, AND PRODUCTS  
CONTAINING SAME

Inv. No. 337-TA-460

03 FEB 19 P2:27

RECEIVED  
OFC OF THE SECRETARY  
US INT'L TRADE COMMISSION

COMMISSION OPINION

Introduction

On October 22, 2002, the presiding administrative law judge (“ALJ”) issued his final initial determination (“ID”) in this investigation finding a violation of section 337 of the Tariff Act of 1930 by respondents Vanderlande Industries Nederland BV of the Netherlands, and Vanderlande Industries of Atlanta, Georgia in the importation into the United States, the sale for importation, and the sale within the United States after importation of certain sortation system products that are covered by claims 1 and 4 of U.S. Patent No. 5,127,510 (“the ‘510 patent”), owned by complainant Rapistan and exclusively licensed to complainant Siemens Dematic.

Respondent Vanderlande and the Commission investigative attorney (“IA”) petitioned for review of portions of the ID, while complainant Rapistan generally opposed the review. On December 9, 2002, we issued a notice of our decision to review the ID on two issues and adopt the remainder of the ID. We requested submissions on the issues under review and on remedy, the public interest, and bonding. We received main submissions and reply submissions from all the parties on these issues, as well as on remedy, the public interest, and bonding.

## Discussion

### I. Background

The Commission instituted this investigation on July 19, 2001, based upon a complaint filed on June 25, 2001, by Rapistan Systems Advertising Corp. and Siemens Dematic Corp., both of Grand Rapids, Michigan.<sup>1</sup> As noted, the respondents are Vanderlande Industries Nederland BV of the Netherlands, and Vanderlande Industries of Atlanta, Georgia (collectively referred to as “Vanderlande”). Vanderlande Industries Nederland BV of the Netherlands designs and manufactures the accused sortation systems, and Vanderlande Industries of Atlanta, Georgia imports, sells, and installs the accused sortation systems.

Complainants alleged that respondents had violated section 337 by importing into the United States, selling for importation, and selling within the United States after importation certain sortation systems, or components thereof, covered by independent claims 1, 13, 23, 30, and 42 and dependent claims 2, 3, 4, 8, 9, 17, 18, 20, 22, 24, 27, 29, 33, 35, 36, 37, 39, 43, 45, 46, 47, and 49 of the ‘510 patent.<sup>2</sup> The claims at issue were claims 1, 4, 13, 17, 20, 22, 23, 27, 29, 30, 33, 35, 42, 43, and 45. The complaint further alleged that an industry in the United States exists, as required by subsection (a)(2) of section 337.

The ALJ held an evidentiary hearing on June 4-17, 2002. On October 22, 2002, the ALJ issued his final ID, in which he determined that respondents’ sortation systems, and parts thereof, infringe claims 1 and 4 of the ‘510 patent, and that the ‘510 patent is valid and enforceable. Based upon these findings, and a finding that a domestic industry exists, the ALJ found a violation of section 337.

As to remedy, the ALJ issued a recommended determination (“RD”) recommending issuance of a

---

<sup>1</sup> Notice of Investigation, 66 Fed. Reg. 38741 (July 25, 2001).

<sup>2</sup> On April 5, 2002, complainants filed an unopposed motion requesting the termination of the investigation with respect to claims 2, 3, 8, 9, 18, 24, 36, 37, 39, 46, 47, and 49. On May 16, 2002, the ALJ granted the motion in an ID (Order No. 32) and the Commission determined not to review that ID. 67 Fed. Reg. 37440 (May 29, 2002).

limited exclusion order with an exemption for spare parts destined for UPS's Hub 2000 facility. He did not recommend issuance of a cease and desist order. Finally, he recommended a bond of 100 percent of entered value during the Presidential review period. *See* RD at 391-396.

On November 4, 2002, Vanderlande and the IA petitioned for review of portions of the ALJ's final ID, and Rapistan submitted a contingent petition for review, asking that the Commission review certain issues if the Commission decided to review the ID. On November 12, 2002, Vanderlande, Rapistan, and the IA filed reply submissions.

On December 9, 2002, the Commission issued a notice of its decision to review the ID on two violation issues, and requested submissions on those issues and on remedy, the public interest, and bonding. The Commission asked that the parties address the ALJ's construction and finding of infringement of the limitation "contiguous, generally planar surfaces sloping downward from an upper extent of said diverting surface laterally inward and longitudinally forward or rearward" in independent claim 30 and dependent claims 33 and 35 of the '510 patent. The Commission also asked the parties to address the ALJ's conclusions regarding the affirmative defense of equitable estoppel.

## **II. The Products At Issue**

The products at issue are sortation systems and components thereof. *See* ID at 5-6. The term "sortation system" refers to a type of material handling or conveying system in which materials such as boxes or cartons are moved to various locations within, for instance, a warehouse.

There are several types of sortation systems, with the type at issue in this investigation referred to as a "positive sorter" or a "shoe-type sorter." In this type of sorter, diverter shoes ride on conveyer slats and engage parcels traveling on the conveying surface (defined by the upper surface of the slats) to divert the parcels onto exit ramps. All positive sorters have to resist reaction forces operating on the shoes as they move across the slats and engage the parcels. The '510 patent is specifically directed to the design of the shoe and slat components of a positive sorter.

Rapistan's product is a sortation system sold with the trade name RS 200. The accused products manufactured by respondent Vanderlande are known by the trade name "Posisorter" (sometimes referred to as the Mark 2 Posisorter to distinguish an earlier Vanderlande Posisorter known as the Mark 1). Vanderlande has imported and installed a number of Mark 2 Posisorters at a large United Parcel Service (UPS) parcel sorting hub in Louisville, Kentucky called the "Hub 2000." The Mark 2 Posisorter is similar to the patented product in that it is a positive sorter which utilizes slats and shoes. Respondents, however, contended that their product differs significantly in the design of its shoes and slats.

### III. Claim Construction and Infringement Issues

#### A. The ALJ's Claim Construction and Infringement Findings

We determined to review the limitation set forth in bold in the following excerpt from claim 30:

a diverting member joined to said support member and having at least one substantially vertical diverting surface on a lateral end thereof and a plurality of **contiguous, generally planar surfaces sloping downward from an upper extent of said diverting surface laterally inward and longitudinally forward or rearward.**

Two other claims, claims 33 and 35, depend from claim 30.

The ALJ construed this limitation as requiring "at least two surfaces of the diverter surface of the diverter shoe that can contact an article, that are contiguous to other such generally planar surfaces, that slope downwardly from an upper extent of the diverting surface, that also slope laterally inward (i.e., either toward (i) the axis in between the vertical diverting surfaces, in the case of a bi-directional member; or (ii) the opposite side of the member from the diverting surface, in the case of a left-handed or right-handed member), and that also slope either forwardly toward or rearwardly from the direction of flow of the conveyor system." ID at 101.

The ALJ noted that the experts disagreed as to whether the relevant surfaces on the Mark 2's shoe are sloping inwards, as required by the limitation. ID at 167-68. The ALJ relied upon the testimony of Vanderlande's expert, Hoet, who immersed Mark 2 and RS 200 shoes in liquid and then removed them.

Successive photographs depicted the boundary between the liquid and the shoe, and showed the slope of the relevant diverting surfaces of the shoe when mapped topographically. See ID at 168. According to the ALJ, the topographic views indicate that the Mark 2 shoe's diverting surfaces do slope inwards. ID at 168.

The ALJ rejected Vanderlande's and the IA's contention that the diverting surfaces are not "contiguous." ID at 169. He found that the diverting surfaces are contiguous to the forward-sloping surface, which is also covered by the claim, and that the two diverting surfaces do not have to be contiguous to each other. ID at 169.

The ALJ then compared the slopes of the relevant diverting surfaces of the Mark 2 shoe to the orientation of the diverting surfaces on the RS 200 shoe and found that they are both oriented in the same direction. ID at 170. According to the ALJ, because the RS 200 exemplifies the preferred embodiment, this necessarily means that the limitation in question reads on the Mark 2 shoe. Accordingly, the ALJ determined that the element of claim 30 requiring "a plurality of contiguous, generally planar surfaces sloping downward from an upper extent of said diverting surface laterally inward and longitudinally forward or rearward" reads literally on the Mark 2 shoe. ID at 171.

#### **B. The Parties' Arguments**

Rapistan argues that the ALJ correctly construed the element "contiguous, generally planar surfaces." Rapistan's Brief at 7. It asserts that the '510 patent's preferred embodiment and the diagrams in the specification implicitly define the limitation. *Id.* Rapistan maintains that the surfaces of the preferred embodiment, 82c, 82d, 82j, and 82k in Figure 4 of the '510 patent correspond to the claim 30 limitation at issue. *Id.* at 8-9. Rapistan further maintains that the ALJ correctly found that surfaces 82c and 82j are the diverting surfaces that exemplify the limitation. It asserts that the term "contiguous" does not require that the diverting surfaces contact each other because like "contiguous row houses," "contiguous" can mean "connected in an unbroken sequence." *Id.* at 11.

Rapistan asserts that the Mark 2 shoe has three surfaces that satisfy the limitation in claim 30. *Id.* at 12. It argues that the Vanderlande’s expert conceded that the corner surfaces of the Mark 2 slope in the same direction as surfaces 82c and 82j of the preferred embodiment, and that a line drawn from the upper extent of the accused diverting surface of the Mark 2 shoe down towards the front surface would have an inward component. *Id.* at 14-15.

Vanderlande generally agrees with the approach taken by the ALJ in construing the claim limitation at issue. Vanderlande’s Brief at 6. It asserts, however, that the ALJ was not clear in defining “inward” and “contiguous,” and that this resulted in a defective infringement analysis. *Id.* at 6.

Vanderlande argues that the Mark 2 shoe has no diverting surfaces that meet the limitation at issue because no surfaces slope downwards and inwards. It points to the testimony of Rapistan’s expert, Radcliffe, who testified that a marble released on the surface at issue would roll outwards and not inwards. *Id.* at 7-8. Vanderlande also asserts that physical inspection of the Mark 2 shoe leaves little doubt as to the orientation of the surfaces. Vanderlande’s Reply Brief at 3.

The IA argues that the ALJ erred in his analysis of the claim limitation with reference to the preferred embodiment. IA’s Brief at 5. He agrees that the orientation of the surfaces on the Mark 2 shoe is similar to those of the preferred embodiment, but he contends that the inventor did not clearly identify those surfaces as meeting the claim limitation in question. *Id.* at 6. The IA asserts that other surfaces of the preferred embodiment meet the claim limitation, so the ALJ’s construction is unnecessary to ensure that the preferred embodiment practices this limitation. *Id.* at 7.

### **C. Conclusion**

The ALJ found that the Mark 2 shoe does not meet another limitation of claim 30 not now under review,<sup>3</sup> and we determined not to review that finding. Therefore, noninfringement of claim 30 (and its

---

<sup>3</sup> See ID at 164 (finding that the Mark 2 shoe does not have a “means defining a glide surface”).

dependent claims) has been established regardless of our findings as to the construction and infringement of the instant limitation.

Turning to the limitation at issue, we find that the ALJ generally correctly construed the limitation, which requires “a plurality of contiguous, generally planar surfaces sloping downward from an upper extent of said diverting surface laterally inward and longitudinally forward or rearward.” ID at 171. He required that two surfaces on the accused device slope downwards and inward (towards the middle of the shoe). Indeed, the parties have not asserted that the ALJ erred in referring to the diagrams and the specification in arriving at an appropriate meaning for the terms “laterally,” “inward,” and “longitudinally.” Moreover, the ALJ’s definitions of these terms are not at odds with their ordinary meanings, and we adopt them.

However, we modify and clarify the ALJ’s claim construction as follows. First, we note that the slope of a surface must, by mathematical necessity, be defined with reference to *two* perpendicular directions. It is meaningless to state that a surface slopes “downward” without specifying a perpendicular direction in which that downward slope occurs. For example, the surface of a ski jump slopes downward as a skier moves away from the starting point of the jump, in a direction perpendicular to “down.” For the limitation at issue, the plain language requires that the surfaces at issue slope downward as an object moves laterally inward -- that is, from the upper extent of the diverting surface toward the lateral center of the shoe. Similarly, the plain language of the limitation requires that the surfaces at issue slope downward as an object moves longitudinally forward or rearward.

We also clarify the construction of “contiguous.” A claim term is generally accorded its ordinary and accustomed meaning. *Johnson Worldwide Assocs., Inc. v. Zebco Corp.*, 175 F.3d 985, 989 (Fed. Cir. 1999) (“[A] court must presume that the terms in the claim mean what they say, and unless otherwise compelled, give full effect to the ordinary and accustomed meaning of claim terms.”). The relevant dictionary definitions of “contiguous” are “being in actual contact: touching along a boundary or at a



point” or “touching or connected throughout in an unbroken sequence.” RX-641 at 250 (Merriam-Webster’s Collegiate Dictionary, tenth ed.). Complainants have not pointed to any clear language in the patent itself, or in the patent prosecution history, indicating that “contiguous” was intended to have anything other than its ordinary meaning. In fact, the “contiguous” deflecting surfaces referred to in the description of the preferred embodiment (Column 4, lines 3-6, 28-30, 41-42) all meet the above dictionary definition, as all are touching or connected throughout in an unbroken sequence.

In *Honeywell, Inc. v. Victor Co. of Japan*, 298 F.3d 1317 (Fed. Cir. 2002), the court stated that the most common meaning of “contiguous” connotes actual contact. 298 F.3d at 1324. However, in that case, the court afforded a broader meaning to “contiguous” based on the clear intent of the inventor, as found in the prosecution history, to define “contiguous” as including “near, though not in contact; neighboring, adjoining; near in succession.” 198 F.3d at 1323. However, the Federal Circuit concluded that, even under this broader definition chosen by the inventor, two elements cannot be “contiguous” if they are separated by an “intervening structure” at every point. 198 F.3d at 1324-25.<sup>4</sup>

As stated above, there is no indication in the instant investigation that the patentee ascribed anything other than the ordinary dictionary definition to “contiguous.” Therefore, we construe this term to require that two surfaces meeting the slope limitation be adjacent to and contacting each other, with no intervening surfaces that do not meet the slope limitation. However, we note that even if a broader definition were appropriate, as in *Honeywell*, two surfaces cannot be “contiguous” if there is an intervening surface at every point.

---

<sup>4</sup> Rapistan’s assertion that the lower 48 states of the United States are considered contiguous even though not every state borders every other state is not an analogous situation. In the case of the United States, there is no intervening structure that is not a state, and thus, Maine and Washington are said to be “contiguous,” despite the fact that they do not border one another. The ALJ’s analogy to slices of a pizza is also misplaced because, unlike the case for a pizza, here the accused surfaces are separated by surfaces which qualify as “intervening structures.” See ID at 171 n.14.

We find that the ALJ erred in his infringement analysis by relying upon the configuration of the shoe of Rapistan's commercial embodiment of the '510 patent, the RS 200 sortation system. The ALJ concluded that the surfaces of the Mark 2 shoe slope in the same direction as the Rapistan RS 200 shoe; he then based his finding that the Mark 2 shoe meets the claim limitation primarily on this fact. ID at 170. This was error. "[W]e have repeatedly said it is error for a court to compare in its infringement analysis the accused product or process with the patentee's commercial embodiment ... the only proper comparison is with the claims of the patent." *Zenith Laboratories, Inc. v. Bristol-Meyers Squibb Co.*, 19 F.3d 1418, 1423 (Fed. Cir. 1994).

In fact, a visual examination of the actual Mark 2 shoe reveals that the two accused surfaces of that shoe (surfaces A and B) do not slope downward and inward; rather, they slope downward and outward. *See* CPX-28, the Mark 2 shoe. This fact is confirmed by Rapistan's expert who testified that a marble placed on either one of the accused surfaces of the Mark 2 shoe would roll outward. Radcliffe Tr. at 1255 (quoted in Vanderlande's Brief at 7-8). Accordingly, these surfaces do not satisfy the claim limitation requiring that they slope downward and inward. Whether the surfaces slope the same way as certain surfaces on the RS 200 shoe is irrelevant.

We also do not agree with the ALJ's conclusion that the relevant surfaces of the Mark 2 shoe are "contiguous."<sup>5</sup> The surfaces in question are not adjacent to each other, and do not contact each other at any point. Even under a broader definition of "contiguous," as used by the court in *Honeywell* due to the clear instruction it found in the prosecution history of the patent at issue there, the surfaces in question are not contiguous. They are on opposite sides of the shoe, and therefore cannot be considered to be "near" each other. Moreover, there is a large surface on the front of the Mark 2 that is an "intervening structure," *i.e.*, a surface that does not satisfy the downward/inward slope limitation. *See* CPX-28. Thus, the accused surfaces of the Mark 2 are not contiguous.

---

<sup>5</sup> ID at 171.

We therefore find that the relevant surfaces of the Mark 2 shoe do not meet the claim 30 limitation in issue because they do not slope downward and inward, and they are not contiguous.

#### **IV. The Affirmative Defense of Equitable Estoppel**

In order to sustain the affirmative defense of equitable estoppel, an alleged patent infringer must establish three elements: (1) misleading conduct by the patentee leading the infringer to believe that the patentee would not enforce its patent; (2) the infringer's reliance on that conduct; and (3) material prejudice to the infringer based on that reliance. *Aukerman Co. v. R.L. Chaides Constr. Co.*, 960 F.2d 1020, 1041-43 (Fed. Cir. 1992) (*en banc*). The alleged infringer's burden of proof with respect to all three elements is a preponderance of the evidence. *Id.* at 1046. Even where the three elements of equitable estoppel are established, the court must also "take into consideration any other evidence and facts respecting the equities of the parties in exercising its discretion and deciding whether to allow the defense of equitable estoppel to bar the suit." *Aukerman*, 960 F.2d at 1043. Where the defense of equitable estoppel is established, "all relief on a claim may be barred." *Aukerman*, 960 F.2d at 1041.

##### **A. Factual Background**

Rapistan and Vanderlande have a longstanding business relationship and were part of the same company until 1988. When their common ownership ended, the two parties entered into a licensing agreement that lasted from February 29, 1988, until April 30, 1993. FF88. \*\*\* After the license agreement ended in 1993, both Vanderlande and Rapistan's German affiliate, Mannesmann Dematic, competed against each other during 1995 or 1996 to install a sortation system for United Parcel Service ("UPS") at its facilities in Fechenheim, near Frankfurt, Germany. FF369. Vanderlande won that bid and installed Mark 2 Posisorters at the UPS facilities in Fechenheim. FF370, 371. Rapistan never enforced its EP '150 patent, the European counterpart to the '510 patent, against Vanderlande, despite direct competition between Vanderlande and itself for UPS's business in Europe. FF372.

\*\*\* Photos of Vanderlande's Mark 2 Posisorters at the UPS facility near Frankfort were shared with counsel for Rapistan between February 27 and March 3, 1998. FF95. Rapistan's counsel then sent a letter dated June 19, 1998, to Vanderlande stating as follows:

We do not have any specific information that Vanderlande Industries is not respecting Rapistan Systems' rights in the United States under the patents referenced above. This notification is being made in an effort to avoid future disputes. Be advised that the system installed by Vanderlande at United Parcel Service in Frankfurt [Fechenheim], Germany, would constitute an infringement of at least United States Patent 5,127,510 if made, used, sold, or offered for sale in or imported to the United States of America.

RX-462.

Vanderlande received this letter approximately one month before it submitted its bid to UPS for the Hub 2000 project. FF376. In August 1998, UPS awarded Vanderlande the Hub 2000 contract, which was signed in October 1998. FF380.

UPS met with Rapistan personnel in October 1998 and told them that Vanderlande would use the Mark 2 Posisorter for the Hub 2000 project. Raab (Rapistan's vice-president of marketing) subsequently told Brouckman (Rapistan's executive vice-president) that Vanderlande was "allegedly going to use the Posisorter, which would then infringe upon the patent rights of the RS 200 [Rapistan's sortation system] and that if sales wanted to take any kind of action, this was -- this would be an appropriate time to take action." FF383.

On December 8, 1998, Brouckman of Rapistan wrote a letter to Rein van der Lande, then the president of Vanderlande, to propose that Vanderlande buy Rapistan's RS200 sortation system for use at the Hub 2000 facility. FF384. The letter was reviewed and commented upon by Rapistan's counsel, Burkhardt, before being sent. FF385. In his letter, Brouckman characterized his offer to Vanderlande as follows:

This is a win-win situation for everybody. UPS gets proven technology they have already accepted with local US support, you get out from under the potential of a patent infringement on this product, and we get some business.

FF389.

On January 29, 1999, Rein van der Lande wrote back to Brouckman rejecting Rapistan's offer.

FF 388. In his letter, van der Lande also acknowledged receipt of the earlier June 1998 letter from Rapistan, and stated as follows:

From the beginning we were of the opinion that we do not infringe the patents referred to in the above-mentioned letter and this opinion has in the meantime been confirmed by US counsel's opinion.

Taking the above into account we do not see a reason to discuss your offer to conclude a cooperation for the Hub 2000 project of UPS.

FF389.

In approximately May 1999, Rapistan, under its former name Mannesmann Dematic Rapistan Corp., entered into an agreement with UPS to install a system for the sortation of "irregular-sized" packages (the so-called "irregulars system") at the Hub 2000 facility. FF395. There was a contractual obligation for Rapistan and Vanderlande to cooperate and coordinate during the design and installation of the irregulars system at Hub 2000, but the ALJ found that "the facts do not suggest that the relationship was particularly warm or 'cooperative.'" Rather, the ALJ determined that "the facts suggest that both parties did whatever UPS wanted them to do when asked, and no more." ID at 277, FF411-13.

The first Vanderlande Mark 2 Posisorters arrived at the Hub 2000 facility in September or October 1999. FF414. A year later, on October 3, 2000, Rapistan's lawyers visited the Hub 2000 site to inspect the Mark 2 Posisorters, and they provided a written opinion to Rapistan concerning their inspection later the same month. FF105. Approximately nine months later, on June 25, 2001, Rapistan filed its section 337 complaint with the Commission.

A summary of the critical dates is as follows:

1997: UPS invited Rapistan and Vanderlande to bid on the installation of the Hub 2000 sortation system. UPS allowed Rapistan to view its facility at Fechenheim in September 1997, where Vanderlande Mark 2 Posisorters were used.

June, 1998: Approximately one month before Vanderlande submitted its bid for the Hub 2000, Rapistan sent a letter to Vanderlande stating that Vanderlande's Mark 2 Posisorters as installed at the UPS facility at Fechenheim "would constitute an infringement of at least United States Patent 5,127,510 if made, used, sold, or offered for sale in or imported to the United States of America."

August, 1998: UPS awarded the Hub 2000 contract to Vanderlande.

October, 1998: UPS told Rapistan that Vanderlande would use the Mark 2 Posisorter for the Hub 2000 facility.

December, 1998: Rapistan sent a letter to Vanderlande proposing that Vanderlande use Rapistan's RS200 sortation system at the Hub 2000 facility to avoid "the potential of a patent infringement on this product."

January, 1999: Vanderlande replied that "we were of the opinion that we do not infringe the patents" and "we do not see a reason to discuss your offer to conclude a cooperation for the Hub 2000 project of UPS."

May, 1999: Rapistan entered into an agreement with UPS to install a system for the sortation of "irregular-sized" packages at the Hub 2000 facility.

September or October 1999:  
The first Vanderlande Mark 2 Posisorters arrived at the Hub 2000.

October 3, 2000: Rapistan's lawyers visited the Hub 2000 site to inspect the Mark 2 Posisorters.

June 25, 2001: Rapistan filed its section 337 complaint with the Commission.

**B. Whether Rapistan through misleading words, conduct, and/or silence led Vanderlande to infer that Rapistan did not intend to enforce the '510 patent against Vanderlande.**

The first element of the defense of equitable estoppel requires a patentee to "communicate something in a misleading way" to an alleged infringer. *Aukerman*, 960 F.2d at 1042. The "something" "is that the accused infringer will not be disturbed by the plaintiff patentee in the activities in which the former is currently engaged." *Id.* We do not believe that Rapistan's silence during the installation of the UPS Hub 2000 project "[gave] rise to the necessary inference that the claim against the defendant is abandoned." *Aukerman*, 960 F.2d at 1042. We do not believe that Rapistan's two and a half year silence from December 1998 to June 2001 was sufficiently misleading to overcome two clear warnings from

Rapistan that it intended to enforce its U.S. patent rights against Vanderlande if Mark 2 Posisorters with the accused slats and shoes were imported into the United States and installed at the Hub 2000 facility.

While we believe the ALJ was correct to consider Rapistan's failure to sue Vanderlande in Europe for infringing Rapistan's European patent,<sup>6</sup> we give little weight to that failure to sue. \*\*\*

Rapistan clearly warned Vanderlande that it would enforce its U.S. patent rights if the accused product was imported into the United States. Approximately one month before Vanderlande submitted its bid for the Hub 2000 project, Rapistan sent Vanderlande a letter stating that while “[w]e do not have any specific information that Vanderlande Industries is not respecting Rapistan Systems' rights in the United States ... [t]his notification is being made in an effort to avoid future disputes.” RX-462.

Rapistan then stated that the Mark 2 Posisorters, as installed in the German UPS facility in Fechenheim “would constitute an infringement of at least [the ‘510 patent] if made, used, sold, or offered for sale in or imported to the United States of America.” RX-462. At that time, alternative sortation systems with other slat and shoe configurations were available which Vanderlande could have used at the Hub 2000 facility. FF 438; CX-169; CX-170; CX-171. In October of 1998, Rapistan, after meeting with UPS personnel, learned of the use by Vanderlande of the Mark 2 Posisorter at the Hub 2000 facility. In December of 1998, counsel to Rapistan wrote to Vanderlande proposing that Vanderlande purchase Rapistan's RS200 sortation system for use at the Hub 2000 facility so that Vanderlande could “get out from under the potential of a patent infringement.” FF389. Thus, Rapistan, once alerted to the use of the Mark 2 Posisorter at the Hub 2000 facility, put Vanderlande on notice that use of the same slats and shoes as used in the Mark 2 Posisorter at the UPS facility in Fechenheim, Germany would constitute

---

<sup>6</sup> Rapistan's European conduct is among the factors that can be considered in applying the doctrine of equitable estoppel. “[A]ny other evidence and facts respecting the equities of the parties” must be considered in deciding whether to allow the defense of equitable estoppel to bar a suit. *Auckerman*, 906 F.2d at 1043. However, the evidence indicates that Vanderlande had strong reason to suspect that Rapistan would enforce its U.S. patent rights if Vanderlande used Mark 2 Posisorters at the Hub 2000 facility.

infringement of the claims of the '510 patent, and that Rapistan intended to enforce that patent.

Vanderlande nonetheless decided to import the Mark 2 Posisorters with the accused slats and shoes despite the fact that Rapistan had twice warned that doing so would infringe the '510 patent.

Vanderlande argues that, although Rapistan's letters were clear statements of intent to enforce the '510 patent, Rapistan's failure to sue in Europe, Rapistan's two and a half year silence in the United States, and Rapistan's cooperation with Vanderlande in building the Hub 2000 facility were misleading. We disagree. Regardless of Rapistan's European activity, Rapistan twice warned Vanderlande that importation of the Mark 2 Posisorter into the United States would, in Rapistan's view, constitute infringement of the '510 patent, and that Rapistan would accordingly enforce its U.S. patent. To those warnings Vanderlande replied that "we were of the opinion that we do not infringe." FF389.

Vanderlande then imported the accused Mark 2 Posisorter with the accused slats and shoes and Rapistan, after confirming that the accused slats and shoes were used on the Mark 2 Posisorters installed at the Hub 2000, filed its section 337 complaint with the Commission.

The accused product is a sortation system. The accused slats and shoes are components of the overall sortation system. They were imported in component form and installed as part of a sortation system at the Hub 2000. ID at 392. Thus, it seems plausible, and at the least there is no unequivocal evidence to the contrary, that Rapistan did not know what type of slats and shoes Vanderlande was importing into the United States before October of 2000 when Rapistan personnel traveled to the Hub 2000 site, observed the installed slats and shoes, and determined whether those products were redesigned, sourced domestically, or imported. Nine months after Rapistan confirmed that the accused shoes and slats were being used at the Hub 2000 facility, Rapistan, as it had twice warned Vanderlande it would do, initiated this investigation. In view of these facts, we do not believe that Rapistan's inaction was so unreasonable as to be misleading or that Rapistan's delay in filing supports an inference that Rapistan did not intend to enforce its patent rights in the United States against Vanderlande.



Accordingly, we find that Vanderlande has not demonstrated by a preponderance of the evidence that Rapistan's failure to sue Vanderlande in Europe and Rapistan's two and a half year delay in bringing suit in the United States satisfies the misleading conduct element of the equitable estoppel defense.

**C. Whether Vanderlande relied on any alleged misleading conduct by Rapistan.**

As to the reliance element of the equitable estoppel defense, we find that Vanderlande has not proven by a preponderance of the evidence that it relied on a belief that Rapistan would not sue in deciding to import the Mark 2 Posisorter. Shortly after receiving Rapistan's two threats to enforce its U.S. patent, Vanderlande went ahead with the importation of the Mark 2 Posisorter with the accused shoes and slats. *Van der Lande Tr.*, pp.1662; 1671-1672. The record indicates that it is not likely that Vanderlande did not proceed to use the Mark 2 Posisorter at the Hub 2000 facility because it thought complainants would not sue them. Rather, Vanderlande used the Mark 2 Posisorter at the Hub 2000 facility because it thought its product was non-infringing. Rapistan warned Vanderlande twice that it would enforce the '510 patent. However, Vanderlande went ahead with the Mark 2 Posisorter in the belief "from the beginning" "that we do not infringe" the '510 patent. FF389.

The ALJ relied on the testimony of Vanderlande's CEO that it was Rapistan's conduct that led Vanderlande to proceed with the use of the Mark 2 Posisorter at Hub 2000 facility, ignoring a variety of available alternatives. However, at the time of its decision to use the Mark 2 Posisorter, Vanderlande had every reason, in view of Rapistan's letters, to believe that it would be sued if it imported the Mark 2 Posisorter. Other than the self-serving testimony of Vanderlande's CEO, there is no evidence that Vanderlande ever seriously considered any other option; it was evidently convinced that its product did not infringe the '510 patent.

The "reliance" element requires more than a belief that one will not be sued; it requires "taking some action" in substantial reliance on the patentee's misleading conduct. *Aukerman*, 960 F.2d at 1042-43. The ALJ did not find that Vanderlande changed its conduct in any way in response to Rapistan's

delay in filing suit in the United States. Vanderlande could have used different equipment, or redesigned the Mark 2 Posisorter to make it non-infringing. ID at 299. There is, however, no evidence that Vanderlande seriously considered either option in the face of Rapistan's threats to sue. We therefore find that Vanderlande has not demonstrated, by a preponderance of the evidence, that the reliance element of the equitable estoppel defense is satisfied.

**D. Whether Vanderlande, due to its alleged reliance, would be materially prejudiced if Rapistan is allowed to proceed with its infringement claim.**

As to the third element of an equitable estoppel defense, we agree with the ALJ that Vanderlande would not, due to its (presumed) reliance, be materially prejudiced if Rapistan is allowed to proceed with its infringement claim under the '510 patent. Economic prejudice may be a change of economic position by the alleged infringer during the period of delay in bringing suit wherein the alleged infringer suffers the loss of monetary investments or incurs damages which likely would have been prevented had the patentee asserted its infringement claim earlier. *Aukerman*, 960 F.2d at 1033, 1043. Vanderlande alleges economic prejudice stemming from its investment in U.S. operations, its investment in the Hub 2000, its loss of opportunity to consider obviously non-infringing alternatives, its loss of opportunity to consider exercising a walk-away clause in its contract with UPS for the Hub 2000 project, and the impact on UPS.

The reliance and prejudice elements of the equitable estoppel defense are linked because the material prejudice claimed by Vanderlande stems from actions taken in purported reliance on Rapistan's misleading conduct. Since we do not find that Vanderlande has shown any change in its conduct based on Rapistan's conduct or lack of action, we also find that the material prejudice element of the equitable estoppel defense cannot be satisfied. *Ecolab, Inc. v. Envirochem, Inc.*, 264 F.3d 1358, 1371 (Fed. Cir. 2001) (upholding summary judgment determination that equitable estoppel did not apply because "Envirochem's firm belief from the outset that its product was noninfringing . . . led the court to the conclusion that [Envirochem's actions] were merely business decisions to capitalize on a market

opportunity”).

Accordingly, we find that Vanderlande has not demonstrated misleading conduct on the part of Rapistan, that Vanderlande did not rely on any misleading conduct by Rapistan, and that there was no economic prejudice to Vanderlande stemming from the alleged misleading conduct and reliance. We therefore find that Vanderlande has failed to establish that the affirmative defense of equitable estoppel should be applied in this investigation.

## **V. Remedy, the Public Interest, and Bonding**

When the Commission finds a violation of section 337, it must then consider and decide the issues of remedy, the public interest, and bonding. 19 U.S.C. § 1337 (d).

### **A. Remedy**

#### **1. Exclusion Order**

The ALJ recommended issuance of a limited exclusion order barring importation of Vanderlande’s sortation systems and parts thereof that infringe claims 1 and 4 of the ‘510 patent. RD at 391. All of the parties agree that a limited exclusion order is appropriate. However, Vanderlande asks that it be limited to the Mark 2 Posisorter and specifically exempt the Mark 1 Posisorter and other sorters using shoes with a rolling surface, as those devices were not found to infringe the claims 1 or 4 of the ‘510 patent. Vanderlande’s Brief at 43-44.

We agree with the parties that a limited exclusion order is warranted, and it is well within the Commission’s discretion in fashioning a remedy for the violation found in this investigation. However, consistent with standard Commission practice, we have not identified specific models of imported products as non-infringing in the exclusion order.

#### **2. Spare Parts Exemption and Certification Provision**

The parties are in agreement that the limited exclusion order should not cover spare parts for UPS’s Hub 2000 facility. Thus, UPS’s operations at that facility would not be put at risk by the

exclusion order. The ALJ therefore recommended the inclusion in the limited exclusion order of a certification provision to facilitate the importation of spare parts for the Hub 2000 facility. RD at 393.

Vanderlande urges the Commission to expand the ALJ's recommended spare parts exemption for the Hub 2000 facility into a more general exception that would permit the importation of spare parts for other U.S. customers of Vanderlande, specifically, Genesco and Amazon.com. Vanderlande's Brief at 46.

We agree that exempting spare parts destined for UPS's Hub 2000 facility from the limited exclusion order is appropriate under these circumstances. Hub 2000 is a major UPS facility where most of UPS's high-revenue packages are sorted. It appears that UPS was not aware of the infringement dispute between Rapistan and Vanderlande until after the installation of the Mark 2 Posisorters purchased from Vanderlande. Brouckman Tr. at 252-53.

UPS has relied upon Rapistan's assurances that Rapistan does not seek to interfere with the operation of Hub 2000 through any remedy that may issue at the conclusion of this investigation. FF 444. Evidence also suggests that if UPS cannot obtain spare parts for Hub 2000, it will have to shut down the facility. FF 439. Given these facts and the parties' agreement that an exemption for Hub 200 is warranted, we are including an exemption for spare parts for Hub 200 in the limited exclusion order.

However, we do not find that Vanderlande's other U.S. customers merit the same spare parts exemption from the limited exclusion order. Vanderlande asserts that ALJ did not find that the Mark 2 shoes and slats infringe (see Vanderlande's Brief at 42), and thus importation of shoes and slats should generally be permitted. However, in finding contributory infringement, the ALJ found that the slats and shoes of the Mark 2 do not have noninfringing uses and therefore contributorily infringe. ID at 181; FF 244. Therefore, importation of Mark 2 slats and shoes would also constitute a violation of section 337. Moreover, the equities with respect to Vanderlande's other U.S. customers (Amazon and Genesco) differ because it appears they purchased the Mark 2 system after the initiation of this investigation. Also, neither company filed a submission with the Commission advocating an exemption in the limited

exclusion order allowing for the importation of spare parts for their U.S. facilities.

We agree with the parties that a certification provision should be included in the limited exclusion order that would permit importers to certify that the imports are for use as replacement parts at UPS's Hub 2000 facility. The Commission has included certification provisions in exclusion orders where the patent(s) that form the basis of the order cover processes for manufacturing goods and Customs is unable readily to determine how goods sought to be imported were made. *See Certain Abrasive Products, Made Using a Process For Making Powder Preforms, and Product Containing Same*, Inv. No. 337-TA-449; *Certain Acid Washed Denim Garments and Accessories*, Inv. No. 337-TA-324, Commission Op. at 23 (Aug. 14, 1992). Similarly, when it is not readily apparent how the infringing products are to be used and such use is significant, as in this instance, a certification provision is appropriate.

### **3. Cease and Desist Order**

The parties are in agreement that it is not necessary to issue a cease and desist order in this investigation as there is no evidence of an inventory of infringing products in the United States. RD at 394. Commission practice is not to issue a cease and desist order when there is no such inventory, and therefore, consistent with the ALJ's recommendation, we decline to issue a cease and desist order.

#### **B. Public Interest**

The parties do not assert that the public interest factors preclude the issuance of a limited exclusion order in this investigation.

#### **C. Bond**

The ALJ determined that the bond during the Presidential review period should be in the amount of 100 percent of the entered value of the infringing Vanderlande products, as price comparisons are unavailable. RD at 396. The IA and Rapistan support this recommendation.

Vanderlande asks that the Commission set the bond at an amount less than 100 percent, asserting that 100 percent is unsupported. Vanderlande's Brief at 46. It maintains that only its sortation systems were found to infringe, so the bond should be set at only a *de minimis* amount. *Id.*

Commission precedent supports a bond of 100 percent of entered value in cases like this one where it is undisputed that calculation of a bond based on price differentials is impossible. *See, e.g., Certain Variable Speed Wind Turbines and Components Thereof*, Inv. No. 337-TA-376, Commission Opinion at 27-28 and 40 (September 23, 1996); *Certain Electrical Wire Discharge Machining Apparatus and Components Thereof*, Inv. No. 337-TA-290, Commission Opinion at 20 (March 16, 1990). Thus, we have set the bond during Presidential review at 100 percent of the entered value of the imported products.

**CERTIFICATE OF SERVICE**

I, Marilyn R. Abbott, hereby certify that the attached **Commission Opinion**, was served upon David H. Hollander, Commission Investigative Attorney, and the following parties via first class mail and air mail where necessary on February 19, 2003.

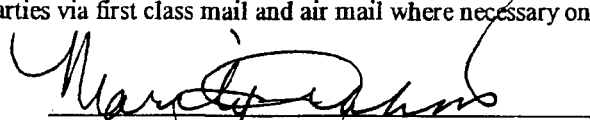

Marilyn R. Abbott, Secretary  
**U.S. International Trade Commission**  
500 E Street, SW - Room 112  
Washington, DC 20436

**ON BEHALF OF COMPLAINANTS RAPISTAN  
SYSTEMS ADVERTISING CORPORATION  
AND SIEMENS DEMATIC CORPORATION:**

V. James Adduci, II, Esq.  
**Adduci, Mastriani and Schaumberg, LLP**  
1200 Seventh Street, NW  
Fifth Floor  
Washington, DC 20036

Daniel Van Dyke, Esq.  
**Van Dyke, Gardner, Linn & Burkhardt, LLP**  
2851 Charlevoix Drive S.E.  
Grand Rapids, Michigan 49588-8695

R. Brent Hatcher, Jr., Esq.  
**Powell, Goldstein, Frazer & Murphy LLP**  
191 Peachtree Street, NE  
Sixteenth Floor  
Atlanta, Georgia 30303

Jerry B. Blackstock, Esq.  
**Hunton and Williams**  
Bank of American Plaza  
Suite 4100  
600 Peachtree Street, NE  
Atlanta, Georgia 30308-2216

Robert r. Merhige, Jr.  
**Hunton and Williams**  
Riverfront Plaza, East Tower  
951 East Byrd Street  
Richmond, VA 23219-4074

**ON BEHALF OF VANDERLANDE  
INDUSTRIES NEDERLAND BV AND  
VANDERLANDE INDUSTRIES  
INCORPORATED:**

John M. DiMatteo, Esq.  
**Patterson Belknap Webb and Tyler LLP**  
1133 Avenue of the Americas  
New York, New York 10036-6710

Cecilia H. Gonzalez, Esq.  
**Howrey Simon Arnold and White LLP**  
1299 Pennsylvania Avenue, NW  
Washington, DC 20004

**CORRECTION NOTICE**  
**UNITED STATES INTERNATIONAL TRADE COMMISSION**  
**Washington, DC 20436**

**In the Matter of**

**CERTAIN SORTATION SYSTEMS,  
PARTS THEREOF, AND PRODUCTS  
CONTAINING SAME**

**Inv. No. 337-TA-460**

DEC 11 11 02 AM '02

000027

**NOTICE OF COMMISSION DECISION TO REVIEW PORTIONS OF A FINAL  
INITIAL DETERMINATION FINDING A VIOLATION OF SECTION 337; SCHEDULE  
FOR FILING WRITTEN SUBMISSIONS ON THE VIOLATION ISSUES UNDER  
REVIEW AND ON REMEDY, THE PUBLIC INTEREST, AND BONDING**

**AGENCY:** U.S. International Trade Commission.

**ACTION:** Notice.

**SUMMARY:** Notice is hereby given that the U.S. International Trade Commission has determined to review portions of the final initial determination issued by the presiding administrative law judge (ALJ) on October 22, 2002, finding a violation of section 337 of the Tariff Act of 1930, in the above-captioned investigation.

**FOR FURTHER INFORMATION CONTACT:** Michael K. Haldenstein, Esq., Office of the General Counsel, U.S. International Trade Commission, telephone 202-205-3041. Copies of the public version of the ID and all other nonconfidential documents filed in connection with this investigation are or will be available for inspection during official business hours (8:45 a.m. to 5:15 p.m.) in the Office of the Secretary, U.S. International Trade Commission, 500 E Street S.W., Washington, D.C. 20436, telephone 202-205-2000. General information concerning the Commission may also be obtained by accessing its Internet server (<http://www.usitc.gov>). The public record for this investigation may also be viewed on the Commission's electronic docket (EDIS-ON-LINE) at <http://dockets.usitc.gov/eol.public>. Hearing-impaired persons are advised that information on the matter can be obtained by contacting the Commission's TDD terminal on 202-205-1810.

**SUPPLEMENTARY INFORMATION:** This patent-based section 337 investigation is before the Commission for a determination of whether to review, in whole or in part, the final initial determination ("ID") of the presiding administrative law judge ("ALJ"), in which he found a violation of section 337 of the Tariff Act of 1930, as amended.



The Commission voted to institute this investigation on July 19, 2001, based upon a complaint filed on June 25, 2001, by Rapistan Systems Advertising Corp. and Siemens Dematic Corp., both of Grand Rapids, Michigan. 66 *Fed. Reg.* 38741 (July 25, 2001). Named as respondents were Vanderlande Industries Nederland BV of the Netherlands, and Vanderlande Industries of Atlanta, Georgia (collectively referred to as "Vanderlande"). Vanderlande Industries Nederland BV of the Netherlands designs and manufactures the accused sortation systems, and Vanderlande Industries of Atlanta imports, sells, and installs the accused sortation systems.

Complainants alleged that respondents had violated section 337 by importing into the United States, selling for importation, and selling within the United States after importation certain sortation systems, or components thereof, covered by independent claims 1, 13, 23, 30, and 42 and dependent claims 2, 3, 4, 8, 9, 17, 18, 20, 22, 24, 27, 29, 33, 35, 36, 37, 39, 43, 45, 46, 47, and 49 of U.S. Patent No. 5,127, 510 ("the '510 patent'"), owned by Rapistan Systems and exclusively licensed to Siemens Dematic. On April 5, 2002, complainants filed an unopposed motion asking for the termination of the investigation with respect to claims 2, 3, 8, 9, 18, 24, 36, 37, 29, 46, 47, and 49. On May 16, 2002, the ALJ granted the motion in an ID (Order No. 32) and the Commission determined not to review that ID. The claims of the '510 patent at issue are therefore claims 1, 4, 13, 17, 20, 22, 23, 27, 29, 30, 33, 35, 42, 43, and 45. The complaint further alleged that an industry in the United States exists, as required by subsection (a)(2) of section 337.

An evidentiary hearing was held on June 4-17, 2002. On October 22, 2002, the ALJ issued his final ID, in which he determined that respondents' sortation systems, and parts thereof, infringe claims 1 and 4 of the '510 patent, and that the '510 patent is valid and enforceable. Based upon these findings, he found a violation of section 337.

The ALJ recommended issuance of a limited exclusion order barring importation of the accused Mark 2 Posisorter and its parts and components. He recommended excluding spare parts destined for UPS's Hub 2000 facility in Louisville, Kentucky from the scope of the limited exclusion order. He also recommended a bond during the Presidential review period in the amount of 100 percent of the entered value of the infringing products.

On November 4, 2002, Vanderlande and the IA petitioned for review of the ALJ's final ID, and Rapistan submitted a contingent petition for review asking that the Commission review certain issues if it decided to review the ID. On November 12, 2002, Vanderlande, Rapistan, and the IA filed reply submissions.

Having reviewed the record in this investigation, including the parties' written submissions, the Commission has determined to review the ID on the following issues: (1) the ID's construction of the element "contiguous, generally planar surfaces sloping downward from an upper extent of said diverting surface laterally inward and longitudinally forward or rearward" in independent claim 30, and dependent claims 33, and 35, and the infringement findings related to this claim element; and (2) the ID's findings regarding the elements of equitable estoppel.

In connection with final disposition of this investigation, the Commission may issue (1) an order that could result in the exclusion of the subject articles from entry into the United States, and/or (2) cease and desist orders that could result in Vanderlande being required to cease and desist from engaging in unfair acts in the importation and sale of such articles. Accordingly, the Commission is interested in receiving written submissions that address the form of remedy, if any, that should be ordered. If a party seeks exclusion of an article from entry into the United States for purposes other than entry for consumption, the party should so indicate and provide information establishing that activities involving other types of entry either are adversely affecting it or are likely to do so. For background information, see the Commission Opinion, *Certain Devices for Connecting Computers via Telephone Lines*, Inv. No. 337-TA-360, USITC Publication 2843 (Dec. 1994).

If the Commission contemplates some form of remedy, it must consider the effects of that remedy upon the public interest. The factors the Commission will consider include the effect that an exclusion order and/or cease and desist orders would have on (1) the public health and welfare, (2) competitive conditions in the U.S. economy, (3) U.S. production of articles that are like or directly competitive with those that are subject to investigation, and (4) U.S. consumers. The Commission is therefore interested in receiving written submissions that address the aforementioned public interest factors in the context of this investigation.

If the Commission orders some form of remedy, the President has 60 days to approve or disapprove the Commission's action. During this period, the subject articles would be entitled to enter the United States under a bond, in an amount to be determined by the Commission and prescribed by the Secretary of the Treasury. The Commission is therefore interested in receiving submissions concerning the amount of the bond that should be imposed.

**WRITTEN SUBMISSIONS:** The parties to the investigation, interested government agencies, and any other interested parties are encouraged to file written submissions on the violation issues under review, and on the issues of remedy, the public interest, and bonding. Such submissions should address the recommended determination by the ALJ on remedy and bonding and the ALJ's conclusions concerning the two violation issues. Complainant and the IA are also requested to submit proposed remedial orders for the Commission's consideration. Written submissions and proposed remedial orders must be filed no later than the close of business on December 23, 2002. Reply submissions must be filed no later than the close of business on December 30, 2002. No further submissions will be permitted unless otherwise ordered by the Commission.

Persons filing written submissions must file with the Office of the Secretary the original and 14 true copies thereof on or before the deadlines stated above. Any person desiring to submit a document (or portion thereof) to the Commission in confidence must request confidential treatment unless the information has already been granted such treatment during the proceedings. All such requests should be directed to the Secretary of the Commission and must include a full statement of the reasons why the Commission should grant such treatment. See 19 C.F.R. § 201.6. Documents for which confidential treatment is granted by the Commission will be treated accordingly. All nonconfidential written submissions will be available for public inspection at the Office of the Secretary.

This action is taken under the authority of section 337 of the Tariff Act of 1930, 19 U.S.C. § 1337, and sections 210.42, 210.43, 210.45, and 210.50 of the Commission's Rules of Practice and Procedure, 19 C.F.R. §§ 210.42, 210.43, 210.45, and 210.50.

By order of the Commission.

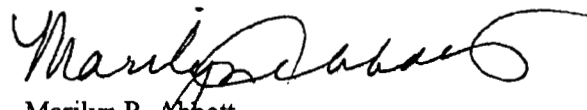

Marilyn R. Abbott  
Secretary

Issued: December 11, 2002

**CERTIFICATE OF SERVICE**

I, Marilyn R. Abbott, hereby certify that the attached **Corrected Notice of Commission Decision to Review Portions of a Final Initial Determination Finding a Violation of Section 337; Schedule for Filing Written Submissions on the Violation Issues Under Review and on Remedy, the Public Interest, and Bonding**, was served upon David H. Hollander, Commission Investigative Attorney, and the following parties via first class mail and air mail where necessary on December 12, 2002.

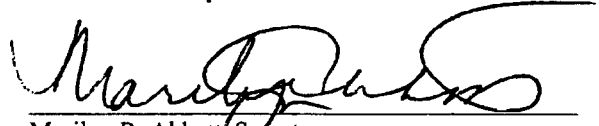

Marilyn R. Abbott, Secretary  
U.S. International Trade Commission  
500 E Street, SW - Room 112  
Washington, DC 20436

**ON BEHALF OF COMPLAINANTS RAPISTAN  
SYSTEMS ADVERTISING CORPORATION  
AND SIEMENS DEMATIC CORPORATION:**

V. James Adduci, II, Esq.  
**Adduci, Mastriani and Schaumberg, LLP**  
1200 Seventh Street, NW  
Fifth Floor  
Washington, DC 20036

Daniel Van Dyke, Esq.  
**Van Dyke, Gardner, Linn & Burkhardt, LLP**  
2851 Charlevoix Drive S.E.  
Grand Rapids, Michigan 49588-8695

R. Brent Hatcher, Jr., Esq.  
**Powell, Goldstein, Frazer & Murphy LLP**  
191 Peachtree Street, NE  
Sixteenth Floor  
Atlanta, Georgia 30303

Jerry B. Blackstock, Esq.  
**Hunton and Williams**  
Bank of American Plaza  
Suite 4100  
600 Peachtree Street, NE  
Atlanta, Georgia 30308-2216

Robert r. Merhige, Jr.  
**Hunton and Williams**  
Riverfront Plaza, East Tower  
951 East Byrd Street  
Richmond, VA 23219-4074

**ON BEHALF OF VANDERLANDE  
INDUSTRIES NEDERLAND BV AND  
VANDERLANDE INDUSTRIES  
INCORPORATED:**

John M. DiMatteo, Esq.  
**Patterson Belknap Webb and Tyler LLP**  
1133 Avenue of the Americas  
New York, New York 10036-6710

Cecilia H. Gonzalez, Esq.  
**Howrey Simon Arnold and White LLP**  
1299 Pennsylvania Avenue, NW  
Washington, DC 20004

**PUBLIC VERSION**

**UNITED STATES INTERNATIONAL TRADE COMMISSION**  
Washington, D.C.

**In the Matter of**

**CERTAIN SORTATION SYSTEMS,  
PARTS THEREOF, AND  
PRODUCTS CONTAINING SAME**

**Investigation No. 337-TA-460**

**INITIAL DETERMINATION ON VIOLATION OF SECTION 337  
AND RECOMMENDED DETERMINATION ON REMEDY AND BOND**

Administrative Law Judge Charles E. Bullock

(October 22, 2002)

**Appearances:**

For the Complainants:

V. James Adduci, II, Esq.; Tom M. Schaumberg, Esq.; Steven E. Adkins, Esq.;  
Michael G. McManus, Esq.; and Sarah E. Hamblin, Esq.; of Adduci, Mastriani &  
Schaumberg, L.L.P., of Washington, D.C.

Daniel Van Dyke, Esq.; and Terence J. Linn, Esq.; of Van Dyke, Gardner, Linn &  
Burkhart, L.L.P., of Grand Rapids, Michigan

Jerry B. Blackstock, Esq.; of Hunton & Williams, of Atlanta Georgia

W. Scott Creasman, Esq.; and Leslie B. Zacks, Esq.; of Powell, Goldstein, Frazer &  
Murphy, L.L.P., of Atlanta, Georgia

Jeffrey R. Heinze, Esq., of Siemens Dematic Corp., of Grand Rapids, Michigan

RECEIVED  
OFC OF INT. TRADE  
US INT. COMMISSION

02 NOV 13 09:26

000003

For the Respondents:

Cecilia H. Gonzalez, Esq.; Bert C. Reiser, Esq.; Margaret D. Macdonald, Esq.; Eugene R. Sullivan II, Esq.; of Howrey Simon Arnold & White, L.L.P., of Washington, D.C.

John M. DiMatteo, Esq.; Scott B. Howard, Esq.; Daniel L. Abrams, Esq.; Adeel A. Mangi, Esq.; Betsy C. Tsai, Esq.; of Patterson, Belknap, Webb & Tyler L.L.P., of New York, New York

For the Commission Investigative Staff:

Lynn I. Levine, Esq., Director; T. Spence Chubb, Esq., Supervisory Attorney; and David H. Hollander, Jr., Investigative Attorney; of the Office of Unfair Import Investigations, U.S. International Trade Commission, of Washington, D.C.

**TABLE OF CONTENTS**

DISCUSSION ..... 2

    I.    Introduction ..... 2

    II.   Overview of the Technology ..... 5

    III.  Jurisdiction ..... 8

    IV.  Claim Construction ..... 9

    V.   Infringement ..... 102

    VI.  Domestic Industry ..... 181

    VII.  Invalidity ..... 189

    VIII. Other Defenses ..... 252

FINDINGS OF FACT ..... 306

CONCLUSIONS OF LAW ..... 386

INITIAL DETERMINATION ..... 390

RECOMMENDED DETERMINATION ON REMEDY AND BOND ..... 391

    I.    Remedy ..... 391

    II.   Bond During Presidential Review Period ..... 394

APPENDIX OF EXHIBIT LISTS ..... Appendix

**PUBLIC VERSION**

**UNITED STATES INTERNATIONAL TRADE COMMISSION**  
Washington, D.C.

**In the Matter of**

**CERTAIN SORTATION  
SYSTEMS, PARTS THEREOF,  
AND PRODUCTS CONTAINING  
SAME**

**Investigation No. 337-TA-460**

**INITIAL DETERMINATION ON VIOLATION OF SECTION 337  
AND RECOMMENDED DETERMINATION ON REMEDY AND BOND**

Administrative Law Judge Charles E. Bullock

(October 22, 2002)

Pursuant to the Notice of Investigation, 66 Fed. Reg. 38741 (July 25, 2001), and Rule 210.42(a) of the Rules of Practice and Procedure of the United States International Trade Commission, 19 C.F.R. § 210.42(a), this is the Administrative Law Judge's Initial Determination in the Matter of Certain Sortation Systems, Parts Thereof, and Products Containing Same, Investigation No. 337-TA-460.

The Administrative Law Judge hereby determines that a violation of Section 337 of the Tariff Act of 1930, as amended, has been found in the importation into the United States, the sale for importation, or the sale within the United States after importation of certain sortation systems, parts thereof, and products containing same by reason of infringement of claims 1 and 4 of U.S. Letters Patent No. 5,127,510, and that a domestic industry exists in the United States that practices the patent at issue.



## **DISCUSSION**

### **I. Introduction**

#### **A. Procedural History**

On June 25, 2001, complainants Rapistan Systems Advertising Corp. and Siemens Dematic Corp. (collectively, "Complainants" or "Rapistan") filed a complaint with the Commission pursuant to Section 337 of the Tariff Act of 1930, as amended, 19 U.S.C. § 1337. Supplements to the complaint were subsequently filed on July 9, 2001 and July 13, 2001. The complaint, as supplemented, asserts unfair methods of competition and unfair acts in violation of Section 337 by Respondents Vanderlande Industries Nederland BV and Vanderlande Industries, Inc. (collectively, "Respondents" or "Vanderlande") in connection with the importation, sale for importation, and sale within the United States after importation of certain sortation systems, parts thereof, and products containing same that are manufactured by Vanderlande. The complaint accuses the Vanderlande products of infringing claims 1, 2, 3, 4, 8, 9, 13, 17, 18, 20, 22, 23, 24, 27, 29, 30, 33, 35, 36, 37, 39, 42, 43, 45, 46, 47 and 49 of U.S. Letters Patent No. 5,127,510 ("the '510 patent") owned by Rapistan. The complaint further alleges that there exists a domestic industry with respect to the '510 patent.

On July 19, 2001, the Commission issued a notice of investigation that was subsequently published in the Federal Register on July 25, 2001. See Notice of Investigation, 66 Fed. Reg. 38741 (July 25, 2001). Vanderlande filed its response to

the complaint and notice of investigation on August 21, 2001. Amendments to the response were filed by Vanderlande on October 1, 2001 and October 16, 2001.

In Order No. 32, which issued as an initial determination on May 16, 2002 and subsequently became a final Commission determination pursuant to 19 C.F.R. § 210.42(h), this investigation was terminated in part with respect to claims 2, 3, 8, 9, 18, 24, 36, 37, 39, 46, 47 and 49 of the '510 patent. Thus, the remaining claims at issue, as identified in the Joint Stipulation of Issues that was submitted by the parties on March 15, 2002, are 1, 4, 13, 17, 20, 22, 23, 27, 29, 30, 33, 35, 42, 43 and 45.

The parties have stipulated as to certain material facts. See Joint Stipulation of Material Facts (May 6, 2002) ("First Stipulation"); Second Joint Stipulation of Material Facts (June 5, 2002) ("Second Stipulation"); Third Joint Stipulation of Material Facts (June 11, 2002) ("Third Stipulation"); Fourth Joint Stipulation of Material Facts (June 14, 2002) ("Fourth Stipulation"). Particular stipulated facts that are relevant to this initial determination are listed herein as findings of fact and cited accordingly.

An evidentiary hearing before the Administrative Law Judge was conducted in this investigation on June 4-17, 2002. After the hearing, post-hearing briefs and reply briefs, together with proposed findings of fact, conclusions of law, and rebuttals

to the same, were filed on July 8, 2002 and July 22, 2002, respectively.<sup>1</sup> Closing argument was conducted on August 7, 2002.

**B. The Parties**

**1. Complainants**

Complainant Rapistan Systems Advertising Corp. ("RSAC") is a Delaware corporation with its principal place of business located at 425 Plymouth Avenue N.E., Grand Rapids, Michigan 49505. **FF 7** (First Stipulation No. 7). RSAC is the owner by assignment of the '510 patent. **FF 9-14** (First Stipulation Nos. 9-14).

Complainant Siemens Dematic Corp. ("Siemens") is a New York corporation with its principal place of business located at 507 Plymouth Avenue N.E., Grand Rapids, Michigan 49505. **FF 8** (First Stipulation No. 8). Siemens is the exclusive licensee of the '510 patent from RSAC. **FF 15** (First Stipulation No. 15). RSAC is a wholly-owned subsidiary of Siemens. **FF 13** (First Stipulation No. 13). Siemens manufactures and sells in the United States a sortation system product line known as the RS-200.

---

<sup>1</sup>The findings of fact of this Initial Determination are designated by "FF" and numbered. The post-hearing briefs are cited in this Initial Determination using the following convention:

CIB: Complainants' initial post-hearing brief  
RIB: Respondents' initial post-hearing brief  
SIB: Staff's initial post-hearing brief  
CRB: Complainants' reply post-hearing brief  
RRB: Respondents' reply post-hearing brief  
SRB: Staff's reply post-hearing brief

## **2. Respondents**

Respondent Vanderlande Industries Nederland BV ("VDL-Netherlands") is a Netherlands corporation with its principal place of business located at Vanderlandelaan 2, Veghel 5466 RB, Netherlands. **FF 21** (First Stipulation No. 21). VDL-Netherlands designs and manufactures accused sortation systems and components thereof in the Netherlands and then imports those products or sells them for importation into the United States.

Respondent Vanderlande Industries, Inc. ("VDL-U.S.") is a Delaware corporation with its principal place of business located at 1765 West Oak Parkway, Suite 700, Marietta, Georgia 30062-2260. **FF 22** (First Stipulation No. 22). VDL-U.S. has a branch office located at 8001 Crittenden Drive, Louisville, Kentucky 40209-1716. **FF 23** (First Stipulation No. 23). VDL-U.S. sells, imports, and installs in the United States accused sortation systems and components thereof manufactured by VDL-Netherlands.

## **II. Overview of the Technology**

Within the material handling industry, sortation systems are variously referred to as sorters, sortation conveyors, sortation conveying systems, and sortation systems, among other designations. There are several different categories of sortation systems including, without limitation, stationary-type, carrier-type, and diverter-type sortation systems (a sub-category of positive displacement-type sortation systems), that are specified for a given application based on a number of factors. The specific type of

---

sortation system at issue in this investigation is known as a "positive sortation system," or a "shoe-type sorter."

In general, sortation systems consist of a main or trunk conveyor line (resembling a highway) and a plurality of conveyor branches (resembling highway off-ramps), arranged in a spaced-apart relationship to one another, along one or both sides of the main conveyor or trunk line. These conveyor branches are also referred to as sortation spurs, discharge chutes, discharge lines, spur lines, take-away lines, take-away conveyors, and shipping lanes, among other designations.

In the prior art, the conveying surface in diverter-type sortation systems was made up of a series of non-rotating tubes connected together to form a closed loop. The tubes advanced to carry the packages forward and then returned beneath the sorter, like the loop of a conveyor belt. A series of diverter shoes (also known as pusher shoes) advanced with the conveying surface and traveled from side-to-side along the tubes. The diverter shoes were moved sideways to engage positively the side of the selected package as it was conveyed along the main conveyor line to push the selected package off the main conveyor line and onto an appropriate conveyor branch. All of the conveyed packages were similarly directed to appropriate conveyor branches, thereby sorting the packages for delivery to their proper unloading points. Therefore, the tubes formed the conveying surface, and the diverter shoes comprised the sorting elements. In the positive sortation systems in this investigation, the specific components at issue are the "slats," which function

like the tubes of the prior art conveying surface, and "shoes" that function like the diverter shoes of the prior art.

**A. The '510 Patent at Issue**

The '510 patent, entitled "Modular Diverter Shoe and Slat Construction," issued on July 7, 1992, based on an application (Application Serial No. 07/758,340) filed on August 28, 1991, that was a continuation of Application Serial No. 07/606,585, filed on October 31, 1990 and thereafter abandoned. FF 24 (First Stipulation No. 24). The named inventors are David H. Cotter, Bernard H. Woltjer, and Curtis E. LeMay.

The '510 patent has a total of fifty-one claims. FF 26 (First Stipulation No. 26). Of these, all five independent claims of the '510 patent are at issue here, consisting of claims 1, 13, 23, 30 and 42. FF 27-28 (First Stipulation Nos. 27 and 28). Also at issue are dependent claims 4 (depending from claim 1), 17 and 20 (both depending from claim 13), 22 (depending from claim 20), 27 (depending from claim 23), 29 (depending from claim 27), 33 (depending from claim 30), 35 (depending from claim 33), and 43 and 45 (both depending from claim 42). FF 28-46 (First Stipulation Nos. 28-46).

**B. The Products at Issue**

The Rapistan products at issue are collectively marketed under the "RS-200" product line. The Vanderlande products at issue are known as the "Mark 2 Posisorter." FF 66-67 (First Stipulation Nos. 67 and 68). Vanderlande has imported and installed the Mark 2 Posisorter at a large United Parcel Service ("UPS") sorting

facility in Louisville, Kentucky, known as the "Hub 2000" project. Physical exemplars of the components of the Mark 2 Posisorter that are relevant to this investigation and that were installed at the Hub 2000 project, together with engineering drawings of for that project, have been introduced into the record by stipulation. FF 49-58 and 62-64 (First Stipulation Nos. 49-58 and 62-64).

### **III. Jurisdiction**

#### **A. Subject Matter Jurisdiction**

The complaint alleges that Vanderlande has violated Subsection 337(a)(1)(A) and (B) in the importation and sale of products that infringe Rapistan's '510 patent. Rapistan and Vanderlande have stipulated that Vanderlande has imported into the United States 90,000 shoes and slats for use in a Mark 2 Posisorter in the United States. FF 107 (First Stipulation No. 122). Accordingly, the Commission has subject matter jurisdiction in this investigation. See Amgen, Inc. v. U.S. International Trade Comm., 902 F.2d 1532, 1536 (Fed.Cir. 1990).

#### **B. Personal Jurisdiction**

Vanderlande has responded to the complaint and has participated in the investigation, thereby submitting to the personal jurisdiction of the Commission. See Certain Miniature Hacksaws, Inv. No. 337-TA-237, U.S.I.T.C. Pub. No. 1948, Initial Determination (unreviewed by Commission in relevant part) at 4, 1986 WL 379287 (U.S.I.T.C., October 15, 1986); FF 5-6 (First Stipulation Nos. 5 and 6).

#### IV. Claim Construction

##### A. Relevant Law

Analyzing whether a patent is infringed “entails two steps. The first step is determining the meaning and scope of the patent claims asserted to be infringed. The second step is comparing the properly construed claims to the device or process accused of infringing.” Dow Chemical Co. v. United States, 226 F.3d 1334, 1338 (Fed.Cir. 2000), citing Markman v. Westview Instruments, Inc., 52 F.3d 967, 976 (Fed.Cir. 1995) (*en banc*), *aff’d*, 517 U.S. 370 (1996) (“Markman”). The first step is a question of law, whereas the second step is a factual determination. Markman, supra. To prevail, the patentee must establish by a preponderance of the evidence that the accused device infringes one or more claims of the patent either literally or under the doctrine of equivalents. Bayer AG v. Elan Pharmaceutical Research Corp., 212 F.3d 1241, 1247 (Fed.Cir. 2000) (“Bayer”).

Concerning the first step of claim construction, “[i]t is well-settled that, in interpreting an asserted claim, the court should look first to the intrinsic evidence of record, *i.e.*, the patent itself, including the claims, the specification and, if in evidence, the prosecution history . . . . Such intrinsic evidence is the most significant source of the legally operative meaning of disputed claim language.” Bell Atlantic Network Services, Inc. v. Covad Communications Group, Inc., 262 F.3d 1258, 1267 (Fed.Cir. 2001) (“Bell Atlantic”).

“In construing claims, the analytical focus must begin and remain centered on the language of the claims themselves, for it is that language that the patentee



chose to use to ‘particularly point[ ] out and distinctly claim[ ] the subject matter which the patentee regards as his invention.’ 35 U.S.C. § 112, ¶ 2.” Interactive Gift Express, Inc. v. CompuServe Inc., 256 F.3d 1323, 1331 (Fed.Cir. 2000) (“Interactive Gift Express”). Thereafter, if the claim language is not clear on its face, “[t]hen we look to the rest of the intrinsic evidence, beginning with the specification and concluding with the prosecution history, if in evidence” for the purpose of “resolving, if possible, the lack of clarity.” Id.

The specification is considered “always highly relevant” to claim construction and “[u]sually, it is dispositive; it is the single best guide to the meaning of a disputed term.” Bell Atlantic, supra, 262 F.3d at 1268. The prosecution history is also examined for a claim’s scope and meaning “to determine whether the patentee has relinquished a potential claim construction in an amendment to the claim or in an argument to overcome or distinguish a reference.” Id.

There is a “heavy presumption” that claim terms are to be given “their ordinary and accustomed meaning as understood by one of ordinary skill in the art,” and in aid of this interpretation, “[d]ictionaries and technical treatises, which are extrinsic evidence, hold a ‘special place’ and may sometimes be considered along with the intrinsic evidence when determining the ordinary meaning of claim terms.” Bell Atlantic, supra, 262 F.3d at 1267-68. However, caution must be used when referring to non-scientific dictionaries “lest dictionary definitions . . . be converted into technical terms of art having legal, not linguistic significance.” Id. at 1267 (internal quotation marks omitted).

The presumption in favor of according a claim term its ordinary meaning is overcome “(1) where the patentee has chosen to be his own lexicographer, or (2) where a claim term deprives the claim of clarity such that there is ‘no means by which the scope of the claim may be ascertained from the language used.’” Bell Atlantic, *supra*, 262 F.3d at 1268. In this regard, “[t]he specification acts as a dictionary ‘when it expressly defines terms used in the claims or when it defines terms by implication.’” *Id.*

“[I]f the meaning of the claim limitation is apparent from the intrinsic evidence alone, it is improper to rely on extrinsic evidence other than that used to ascertain the ordinary meaning of the claim limitation. [citation omitted] However, in the rare circumstance that the court is unable to determine the meaning of the asserted claims after assessing the intrinsic evidence, it may look to additional evidence that is extrinsic to the complete document record to help resolve any lack of clarity.” Bell Atlantic, *supra*, 262 F.3d at 1268-69. “Extrinsic evidence consists of all evidence external to the patent and prosecution history . . . .” Markman, *supra*, 52 F.3d at 980. It includes “such evidence as expert testimony, articles, and inventor testimony.” Bell Atlantic, *supra*, 262 F.3d at 1269. However, “[i]f the intrinsic evidence resolves any ambiguity in a disputed claim, extrinsic evidence cannot be used to contradict the established meaning of the claim language.” DeMarini Sports, Inc. v. Worth, Inc., 239 F.3d 1314, 1322-23 (Fed.Cir.2001). “What is disapproved of is an attempt to use extrinsic evidence to arrive at a claim construction that is clearly at odds with the claim construction mandated by the claims themselves, the

written description, and the prosecution history, in other words, with the written record of the patent.” Markman, supra, 52 F.3d at 979.

In interpreting particular limitations within each claim, “adding limitations to claims not required by the claim terms themselves, or unambiguously required by the specification or prosecution history, is impermissible.” Dayco Products, Inc. v. Total Containment, Inc., 258 F.3d 1317, 1327 (Fed.Cir. 2001), citing Laitram Corp. v. NEC Corp., 163 F.3d 1342, 1347 (Fed.Cir.1998) (“[A] court may not import limitations from the written description into the claims.”). Further, a patent is not limited to its preferred embodiments in the face of evidence of broader coverage by the claims. Acromed Corp. v. Sofamor Danek Group, Inc., 253 F.3d 1371, 1382-83 (Fed.Cir. 2001); Electro Med. Systems S.A. v. Cooper Life Sciences, 34 F.3d 1048, 1054 (Fed.Cir.1994) (“[P]articular embodiments appearing in a specification will not be read into the claims when the claim language is broader than such embodiments.”). “[T]here is sometimes ‘a fine line between reading a claim in light of the specification, and reading a limitation into the claim from the specification.’” Bell Atlantic, supra, 262 F.3d at 1270. On the other hand, a claim construction that excludes the preferred embodiment in the specification of a patent is “rarely, if ever, correct.” See Vitronics Corp. v. Conceptoronic, Inc., 90 F.3d 1576, 1583-34 (Fed.Cir. 1996) (“Vitronics”).

A patent claim limitation that is written in “means plus function” format is treated differently, however. Such a limitation identifies a function without reciting definite structure in support of that function, and as such is subject to the

requirements of 35 U.S.C. § 112, ¶ 6 in discerning its meaning. Serrano v. Telular Corp., 111 F.3d 1578, 1582 (Fed.Cir. 1997). “Literal infringement of a claim containing a means clause requires that the accused device perform the identical function as that identified in the means clause and do so with structure which is the same as or equivalent to that disclosed in the specification.” Id. Thus, in distinct contrast to the general rule that particular embodiments in the specification are not read into claim limitations, “means plus function” claim limitations are construed according to “[d]isclosed structure . . . which is described in a patent specification, including any alternative structures identified.” Id. at 1583. In other words, correctly construed “means plus function” limitations of claims cover “equivalents of the described embodiments.” Texas Instruments, Inc. v. U.S. Int’l. Trade Comm., 805 F.2d 1558, 1562 (Fed.Cir. 1986).

Claims amenable to more than one construction should, when it is reasonably possible to do so, be construed to preserve their validity. Karsten Mfg. Corp. v. Cleveland Golf Co., 242 F.3d 1376, 1384 (Fed.Cir. 2001). However, a claim cannot be construed contrary to its plain language. See Rhine v. Casio, Inc., 183 F.3d 1342, 1345 (Fed.Cir.1999). Claims cannot be judicially rewritten in order to fulfill the axiom of preserving their validity; “if the only claim construction that is consistent with the claim’s language and the written description renders the claim invalid, then the axiom does not apply and the claim is simply invalid.” Id.

**B. The Disputed Claim Terms of the '510 Patent and Their Interpretation**

**1. The Asserted Claims**

The claims of the '510 patent that are at issue in this investigation, with the principal terms in dispute in bold print for emphasis, read as follows:

Claim 1: In a conveying system having a longitudinally moving conveying surface defined by the uppermost ones of a plurality of slats connected at opposite ends in spaced relation with each other to a pair of endless chains; a plurality of diverter shoes each moveably mounted on one of said slats for lateral movement with respect to said conveying surface; and **track means** engaging said diverter shoes for imparting a lateral force to move said diverter shoes laterally to displace product positioned on said conveying surface, wherein the improvement comprises:

each of said slats being defined by a wall formed as a **right cylinder including an outer surface having a planar upper portion defining said conveying surface, and**

each of said diverter shoes having a **support portion including a substantially continuous glide surface surrounding said wall, said glide surface having substantially the same configuration as said outer surface of said slat.**

Claim 4: The conveying system in claim 1 wherein each of said slats is formed by extrusion.

Claim 13: In a conveying system having a longitudinally moving conveying surface defined by the uppermost ones of a plurality of slats connected in spaced relation with each other in an endless web; a plurality of diverter shoes each movably mounted on one of said slats for lateral movement with respect to said conveying surface; and **track means** engaging said diverter shoes for imparting a lateral force to move said diverter shoes laterally to displace product positioned on said conveying surface, wherein the improvement comprises:

each of said slats defined by a **wall having generally planar upper and lower wall portions joined by side wall portions defining joining edges between each of said wall portions;**

each of said diverter shoes having a **support portion** including a **glide surface surrounding said wall**; and

**bearing means** defining a bearing between at least one of said **joining edges** of each of said slats and an engaging portion of said **glide surface** of the corresponding one of said diverter shoes.

Claim 17: The conveying system in claim 13 further including **means defining lateral stabilizing means** between one of said wall portions of each of said slats and an engaging portion of said **glide surface** of the corresponding one of said diverter shoes, said lateral stabilizing means resisting vertical-axis reaction-force-couples.

Claim 20: The conveying system in claim 13 wherein said **support portion** is molded of a polymeric material.

Claim 22: The sortation system in claim 20 wherein said **support portion** is defined by a multiplicity of joined wall segments having substantially the same thickness.

Claim 23: In a conveying system having a longitudinally moving conveying surface defined by the uppermost ones of a plurality of slats connected in spaced relation with each other in an endless web; a plurality of diverter shoes each movably mounted on one of said slats for lateral movement with respect to said conveying surface; and **track means** engaging said diverter shoes for imparting a lateral force to move said diverter shoes laterally to displace product positioned on said conveying surface, wherein the improvement comprises:

each of said slats defined by a **wall having generally planar upper and lower wall portions** joined by side wall portions defining **joining edges between each of said wall portions**;

each of said diverter shoes having a **support portion** includes a **glide surface surrounding said wall**; and

**means defining lateral stabilizing means** between one of said wall portions of each of said slats and an engaging portion of said **glide surface** of the corresponding one of said diverter shoes, said lateral stabilizing means resisting vertical-axis reaction-force-couples.

Claim 27: The conveying system in claim 23 wherein said **support portion** is molded of a polymeric material.

Claim 29: The conveying system in claim 27 wherein said **support portion** is defined by a plurality of joined wall segments having substantially the same thickness.

Claim 30: A diverter shoe for use in a conveyor system having a longitudinally moving conveying surface defined by the uppermost ones of a plurality of slats connected in spaced relation with each other in an endless web; and **track means** extending below said uppermost ones of said slats for engaging and imparting a lateral force to displace selected ones of said diverter shoes laterally with respect to said conveying surface; said diverter shoe comprising:

a **support member** having a glide portion including **means defining a glide surface adapted to glide along one of said slats**; and

a diverting member joined to said support member and having at least one substantially vertical diverting surface on a lateral end thereof and a plurality of **contiguous, generally planar surfaces sloping downward from an upper extent of said diverting surface laterally inward and longitudinally forward or rearward.**

Claim 33: The diverter shoe in claim 30 wherein said **support member** glide portion is molded of a polymeric material.

Claim 35: The diverter shoe in claim 33 wherein said glide portion is defined by a multiplicity of interconnected wall segments having substantially the same thickness.

Claim 42: A diverter shoe for use in a conveyor system having a longitudinally moving conveying surface defined by the uppermost ones of a plurality of slats connected in spaced relation with each other in an endless web; and **track means** extending below said uppermost ones of said slats for engaging and imparting a lateral force to displace selected ones of said diverter shoes laterally with respect to said conveying surface; said diverter shoe comprising:

a **support member** having a glide portion including **means defining a glide surface adapted to glide along one of said slats**;

a diverting portion joined to said **support portion** and having at least one substantially vertical diverting surface on a lateral end thereof; and

wherein said **support member glide** portion is defined by a multiplicity of interconnected wall segments having substantially the same thickness.

Claim 43: The diverter shoe in claim 42 wherein said glide portion is molded of a polymeric material.

Claim 45: The diverter shoe in claim 42 wherein said **support member** includes a follower portion adapted to be engaged by said track means and a base portion defined by said glide portion for mounting of said follower portion, said base portion defined by a plurality of said wall segments arranged in a honey-comb manner.

An interpretation of each of the disputed terms of the foregoing claims follows.

2. **“Track means” (Claims 1, 13, 23, 30, 42)**

According to Rapistan, the claim term “track means” in claims 1, 13, 23, 30 and 42 is a structural element that includes a guide or set of guides that are engageable with the diverter shoes to force them to move laterally. CIB 25. Rapistan further contends that “track means” is not a “means plus function” element under the provisions of 35 U.S.C. § 112, ¶ 6. *Id.* In the alternative, if it were so interpreted, then Rapistan argues that the corresponding structure disclosed in the ‘510 specification is a guide rail. *Id.* It does not, in Rapistan’s view, require a diverter switch. CIB 33. In the alternative, Rapistan asserts, if a diverter switch is required, then it would encompass horizontally-pivoted, vertically-pivoted, pneumatic and electrical switches. CIB 34-35; CRB 31.



Vanderlande argues that “track means” is a “means plus function” element under 35 U.S.C. § 112, ¶ 6, and further argues that the corresponding structure of the “track means” is not only the guide rail that is disclosed in the ‘510 patent, but also a vertically-moving, electrically-driven diverter switch that is disclosed in a patent that is incorporated by reference into the ‘510 patent, which engages the diverter shoes and thereby initiates the lateral force that causes the diverter shoe to change direction and move across the slat. RIB 41-44; RRB 25-28.

The Staff agrees with Vanderlande that “track means” is a “means plus function” element under 35 U.S.C. § 112, ¶ 6. SIB 18-19; SRB 5. The Staff agrees with Rapistan, however, that a diverter switch is not required by the “track means” element. SIB 21; SRB 6-7. In the Staff’s view, the switch and track in a positive sorter like that described in the ‘510 patent perform related but distinct tasks, and interact with related but distinct structures on the shoe. SIB 22.

The claim term “track means” appears in the preambles of independent claims 1, 13, 23, 30 and 42. Sec CX-1 (‘510 patent, cols. 6:12, 63; 7:46; 8:14; 9:1). Of these, claims 1, 13 and 23 are directed to a “conveying system” overall and are written in “Jepson” format, which begins with a preamble reciting an old device, continues with the transition “wherein the improvement comprises,” and concludes with a statement of the new improvement upon the old device that makes up the invention. See 3 Chisum on Patents § 8.06[1][c] (2000) (“Chisum”); also see Ethicon Endo-Surgery, Inc. v. United States Surgical Corp., 93 F.3d 1572, 1577 (Fed.Cir. 1996); Ex parte Jepson, 243 O.G. 525 (Ass’t Comm’r Pat.1917). In a

Jepson claim, the terms in both the preamble describing the prior art and the element constituting the improvement are substantive claim limitations. See Kegel Company, Inc. v. AMF Bowling, Inc., 127 F.3d 1420, 1426 (Fed. Cir. 1997) (“[T]he claim preamble defines not only the context of the claimed invention, but also its scope.”). Thus, with regard to claims 1, 13 and 23, “track means” is an element of prior art conveying systems that substantively limits the scope of the claimed invention.

On the other hand, claims 30 and 42 are directed to a “diverter shoe” and are not written in Jepson format. Thus, the fact that “track means” appears in the preambles of those claims means that it is considered a limitation of those claims if “the claim cannot be read independently of the preamble and the preamble must be read to give meaning to the claim or is essential to point out the invention.” See Chisum, supra, § 8.06[1][d]. However, “track means” is not considered a limitation of those claims if “the preamble merely states a purpose or intended use and the remainder of the claim completely defines the invention.” Id.

If a claim element contains the word “means” and recites a function, it is presumed that the element is a means-plus-function element under 35 U.S.C. § 112, ¶ 6. Wenger Manufacturing, Inc. v. Coating Machinery Systems, Inc., 239 F.3d 1225, 1232 (Fed.Cir. 2001) (“Wenger”). That presumption falls, however, if the claim itself recites sufficient structure to perform the claimed function. Envirco Corp.v.Clestra Cleanroom, Inc., 209 F.3d 1360, 1364 (Fed.Cir. 2000) (“Envirco”). “Conversely, the recitation of some structure in a means plus function element does

not preclude the applicability of section 112(6).” York Products, Inc. v. Central Tractor Farm & Family Center, 99 F.3d 1568, 1574 (Fed.Cir. 1996) (“York”).

Rapistan argues that the word “track” in the claims connotes structure, and as such the addition of the word “means” does not invoke the provisions of 35 U.S.C. § 112, ¶ 6. CIB 25. Since the triggering “means” word is present in the claim element, the presumption applies and a determination must be made as to whether the claim recites “sufficient structure for performing the claimed function, thereby overcoming the presumption of § 112, ¶ 6.” Envirco, supra, 209 F.3d at 1365. This must be done by determining whether the wording of the “track means” element uses language that connotes a reasonably well understood meaning in the art as a name for structure. Watts v. XL Systems, Inc., 232 F.3d 877, 881 (Fed.Cir. 2000) (“Watts”).

In claims 1, 13 and 23, the “track means” element stated in full is “track means engaging said diverter shoes for imparting a lateral force to move said diverter shoes laterally to displace product positioned on said conveying surface.” See CX-1 (‘510 patent, col. 6:12-15 (claim 1); 6:63-66 (claim 13); 7:46-49 (claim 23)). In claims 30 and 42, the full statement of “track means” is only marginally different – “track means extending below said uppermost ones of said slats for engaging and imparting a lateral force to displace selected ones of said diverter shoes laterally with respect to said conveying surface.” See CX-1 (‘510 patent, col. 8:14-17 (claim 30); 9:1-4 (claim 42)). The claimed function in all instances is that of “engaging” the diverter shoes so as to “impart a lateral force” that moves or displaces the shoes laterally on the conveying surface.

In the “Background of the Invention” section of the specification, the following language is found:

Movement of the shoes is effected by a guide pin and coaxial bearing, depending from the shoe, which engage a network of guide tracks beneath the conveying surface. . . . When a package is to be diverted to a spur, a diverter switch is actuated to switch the guide pins for the shoes adjacent the package onto a diagonal track which causes the affected shoes to glide across the slats to divert the package.

CX-1 (‘510 patent, col. 1:23-33) (emphasis added); FF 108. Additional language is found in the “Description of the Preferred Embodiment,” referencing Figure 2 of the ‘510 patent:

Movement of the shoe is guided by a network of guide tracks 39 engaging a bearing 56 and changes in direction of movement are initiated by a diverter switch (not shown) engaging a diverter pin 54.

CX-1 (‘510 patent, col. 3:11-14) (emphasis added); FF 109.

The written description thus specifies two functions of the track network of the preferred embodiment: (i) that of “engaging a diverter pin” of the shoe in order to initiate “changes in direction of movement;” and (ii) that of “caus[ing] the affected shoes to glide across the slats to divert the package.” All parties acknowledge that these functions are distinct from one another, and Vanderlande further contends that the “track means” structure performs these two functions in an inseparable combination. CIB 25; RIB 45-46; RRB 25; SIB 22; also see Hoet Tr. 1962:23-25.

The word “track” is the only structural term of the claim element, and Rapistan argues that it connotes sufficient structure by its ordinary meaning, which Rapistan finds in a dictionary definition to be a rail or set of parallel rails upon which a train or trolley runs. CIB 25; CX-660. However, in the preferred embodiment, the

structures that perform the claimed functions of “engaging” the diverter shoes and “impart[ing] a lateral force” that moves or displaces the shoes laterally on the conveying surface are (i) the diverter switch, which performs the “engaging” function, and (ii) the diagonal portion of the track, which imparts “a lateral force” to the shoe. Neither structure is explicitly defined in any of the claims containing the “track means” element.

In connection with the diagonal track, the foregoing passage from the written description of the ‘510 patent specifically refers to this structural aspect in describing the claimed function: “When a package is to be diverted to a spur, a diverter switch is actuated to switch the guide pins for the shoes adjacent the package onto a diagonal track which causes the affected shoes to glide across the slats to divert the package.” CX-1 (‘510 patent, col. 1:28-33) (emphasis added); FF 110. The trial testimony of Bernard Woltjer, one of the named inventors of the ‘510 patent, affirms the importance of this structural aspect to the “track means” element. See Woltjer Tr. 328:7-15 (“Well, the track means is what I refer to as the angular divert means when I was doing this demonstration. The track means is, in this model, the orange bar that goes across, and it’s the member that forces the shoes to travel across the slats . . .”) (emphasis added), 486:19-487:1; FF 111. Yet the “track means” element of the claims does not describe the “track” as being “diagonal,” and therefore does not identify specific structure for the claimed function of “imparting a lateral force” to laterally displace the diverter shoes on the conveying surface.

The only structure shown in the body of the '510 patent that has anything to do with a track is a small portion of the "network of guide tracks 39" that is depicted in Figure 2:

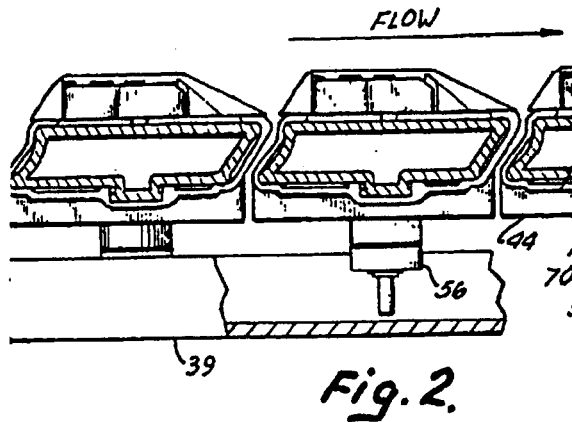

'510 Patent Fig. 2 (Part)

See CX-1 ('510 patent, Fig. 2 (part)); FF 112. This portion, however, is only of a part of the track that parallels the direction of flow. It does not depict the diagonal part of the track system that performs the claimed function of imparting lateral movement to the shoe. See Hoet Tr. 1962:5-22; Cotter Tr. 627:15-630:10; FF 113.

The written description of the '510 patent goes on to state, however, that "[p]ositive displacement sortation systems, such as the type disclosed in U.S. Pat. No. 4,738,347 for DIVERTER SHOE AND DIVERTING RAIL, issued to Gerald A. Brouwer and assigned to the present assignee, have long been known." See CX-1 ('510 patent, col. 1:14-18); FF 114. The written description describes this system as having "a network of guide tracks beneath the conveying surface." See CX-1 ('510

patent, col. 1:25-26); FF 115. In Figure 2 of the '347 Brouwer patent, this network of diagonal rails 31 is shown:

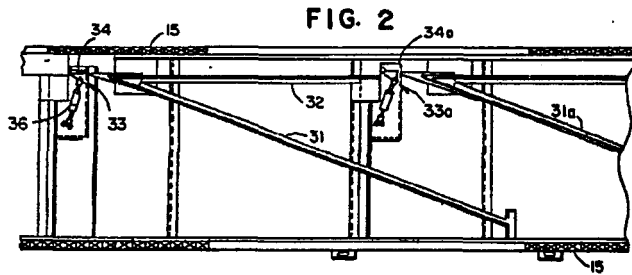

<sup>18</sup>  
**'347 Brouwer Patent Fig. 2**

See RX-333 ('347 Brouwer patent, Fig. 2); FF 116.

The written description of the '510 patent also states that "[t]he modular slats and diverter shoes provided by the present invention are intended to be used in combination with a vertically-actuated diverter switch, as disclosed in commonly-owned U.S. Pat. No. 5,038,912 for a VERTICALLY ACTUATED TRANSFER SYSTEM filed concurrently herewith, David H. Cotter inventor, the disclosure of which is hereby incorporated herein by reference." See CX-1 ('510 patent, col. 5:50-57); FF 117. Figure 1 of the '912 Cotter patent similarly depicts a track network that includes diagonal rails 18:

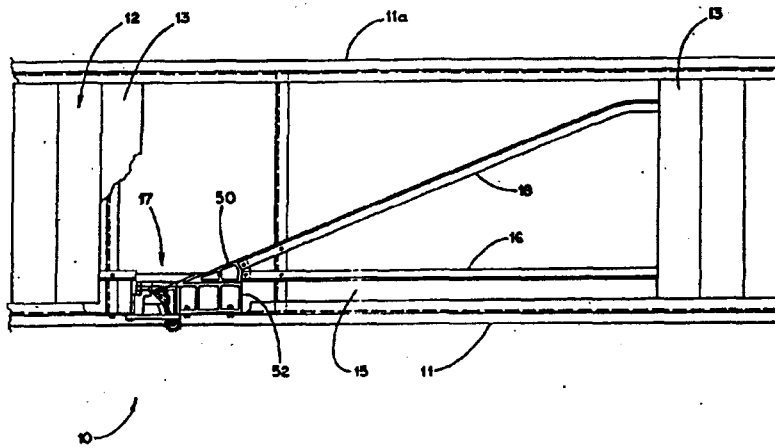

FIG. 1

'912 Cotter Patent Fig. 1

CX-2 ('912 Cotter patent, Fig. 1); FF 118.

Still further, the written description of the '510 patent states that "[b]i-directional diverter shoes are intended to be used in a bi-directional diverting sortation system utilizing a cross-over switch of the type disclosed in commonly-owned co-pending application Ser. No. 606,504 for a TRACK INTERSECTION PIN GUIDE filed concurrently herewith, David H. Cotter, inventor, the disclosure of which is hereby incorporated herein by reference." See CX-1 ('510 patent, col. 5:57-64). That application eventually issued as U.S. Letters Patent No. 5,235,100 to Cotter, et al. FF 119. The Cotter '100 patent depicts in Figure 1 a track network including a "diagonal track 19," shown thus:



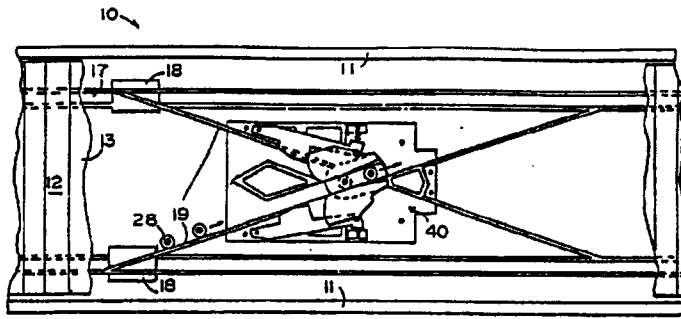

FIG. 1

**'100 Cotter Patent Fig. 1**

CX-3 ('100 Cotter patent, Fig. 1); FF 120.

The claims and written description of a patent are “to be understood for what it meant to one having ordinary skill in the art at the time the application was filed.” In re Koller, 613 F.2d 819, 824 (CCPA 1977); accord, U.S. Steel Corp. v. Phillips Petroleum Co., 865 F.2d 1247, 1251 (Fed.Cir. 1989). Moreover, “[w]hen a document is ‘incorporated by reference’ into a host document, such as a patent, the referenced document becomes effectively part of the host document as if it were explicitly contained therein.” Telemac Cellular Corp. v. Topp Telecom, Inc., 247 F.3d 1316, 1329 (Fed.Cir. 2001). Thus, it is clear from the standpoint of both the prior art ‘347 patent disclosed in the ‘510 patent itself as well as the incorporation by reference of the ‘912 and ‘100 patents that a track network that includes diagonal rails is fully disclosed in the written description of the ‘510 patent and provides the necessary specification of structure to support the claimed function of “impart[ing]

a lateral force” in the “track means” element of the asserted claims. To this extent, therefore, the word “track” in the “track means” element does not impart sufficient structure within the claim by itself, and the claim should be viewed as a “means plus function” claim under 35 U.S.C. § 112, ¶ 6.

The more significant dispute among the parties concerns the appropriate structure for the “engaging” function of the “track means” element. No structure is stated in the claim for this function, and “track means” must, therefore, be read as a “means plus function” element under 35 U.S.C. § 112, ¶ 6, to that extent. The parties dispute, however, whether the diverter switches that are disclosed in the ‘347, ‘912 and ‘100 patents must also be considered part of the claimed structure of the “track means” element of the asserted claims of the ‘510 patent, and if so, whether that structure is limited to the “vertical” diverter switch of the ‘912 patent or encompasses other diverter switches such as the “horizontal” switch that is shown in the ‘347 patent. See CIB 28-31; CRB 31-34; RIB 42-49; RRB 24-28; SIB 20-23; SRB 6-7.

The language of the “track means” element of claims 1, 13 and 23 alludes to two separate functions by speaking of “track means engaging [Function I] said diverter shoes for imparting a lateral force to move said diverter shoes laterally [Function II] to displace product positioned on said conveying surface.” Similarly, the “track means” element of claims 30 and 42 also alludes to two functions by referring to “track means extending below said uppermost ones of said slats for engaging [Function I] and imparting a lateral force [Function II] to displace selected ones of said diverter shoes laterally with respect to said conveying surface.”

As both a diverter switch and diagonal rails are necessary features of the disclosed embodiment with which to perform both claimed functions, the structure of both must be considered together in construing the “track means” element of claims 1, 13, 23, 30 and 42. See Micro Chemical, Inc. v. Great Plains Chemical Co., Inc., 194 F.3d 1250, 1258 (Fed.Cir. 1999) (“§ 112, ¶ 6 requires both identification of the claimed function and identification of the structure in the written description necessary to perform that function. The statute does not permit limitation of a means-plus-function claim by adopting a function different from that explicitly recited in the claim. Nor does the statute permit incorporation of structure from the written description beyond that necessary to perform the claimed function.”).<sup>2</sup>

---

<sup>2</sup>Vanderlande points out that construing “track means” in accordance with 35 U.S.C. § 112, ¶ 6 is consistent with the prosecution history of the ‘510 patent. RIB 42. In Rapistan’s original patent application, Vanderlande notes, the “track means” of claims 30 and 42 initially did not contain any function and only called for a “track means extending below said uppermost ones of said slats.” Id.; see CX-4 (‘510 patent prosecution history at R 028061 and R028063). After allowance, Rapistan abandoned the original application and filed a continuation application, correcting the “track means” elements of claims 30 and 42 to include the function “for engaging and imparting a lateral force to displace selected ones of said diverter shoes laterally with respect to said conveying surface.” RIB 42; CX-4 (‘510 patent prosecution history at R028366 and R028368). This change, Vanderlande contends, changed the limitation so as to embrace the “means plus function requirements of 35 U.S.C. § 112, ¶ 6. RIB 42. This interpretation of the prosecution history is consistent with the above claim construction, but not necessary to that result.

Vanderlande also points out that construing “track means” to include the diverter switch as well as diagonal rails is consistent with Rapistan’s own interpretation of the “track means” element that it took in a previous infringement action in 1996, also involving the ‘510 patent, against Hytrol Conveyor Company, Inc. (“Hytrol”), which was subsequently settled. See RIB 45-46; RRB 25; FF 19-20. (First Stipulation Nos. 19 and 20). Although consistent with the result here, Rapistan’s position in that case does not control or require the outcome here.

Vanderlande further contends, however if diverter switches are included as part of the structure of the “track means element, then horizontal, pneumatic diverter switches cannot be included as “track means” structures because to do so “would violate a fundamental rule of claim construction: an applicant cannot claim what he has explicitly disclaimed.” RIB 47-48, citing Cybor Corp. v. FAS Techs., Inc., 138 F.3d 1448, 1457 (Fed.Cir. 1998) (“Cybor”); KX Indus. L.P. v. PUR Water Purification Prods., Inc., 108 F.Supp.2d 380, 389-90 (D.Del. 2000) (“KX”). Vanderlande points to language in the written specification of the ‘912 patent suggesting that prior-art horizontal diverter switches were unsuitable for the claimed sortation system because they are too slow, and that the vertical switch of the ‘912 patent overcomes these difficulties. RIB 48, quoting from CX-2 (‘912 patent, cols. 5:60-6:31). This language, according to Vanderlande, evinces that the patentee, by incorporating the ‘912 patent into the ‘510 patent, expressly disclaimed prior art horizontal switches from the scope of the “track means” element of the ‘510 patent. RRB 25-26, citing J&M Corp. v. Harley-Davidson, Inc., 269 F.3d 1360, 1367-68 (Fed.Cir. 2001); Ballard Med. Prods. v. Allegiance Healthcare Corp., 268 F.3d 1352, 1359 (Fed.Cir. 2001) (“Ballard”); Signtech USA, Ltd. v. Vutek, Inc., 174 F.3d 1352, 1356-57 (Fed.Cir. 1999) (“Signtech”).

The Staff points out, however, that if this contention were correct, and the only switch structure permitted by the “track means” limitation is the vertically-moving switch of the ‘912 patent, then the ‘510 patent could not be infringed absent infringement of the ‘912 patent, which to the Staff would lead to an illogical result.

---

SRB 6, citing Modine Manufacturing Co. v. U.S. Int'l Trade Comm'n, 75 F.3d 1545, 1553 (Fed.Cir.), cert. denied, 518 U.S. 1005 (1996) (“incorporation by reference does not convert the invention of the incorporated patent into the invention of the host patent”).

Neither the language of the “track means” claim element nor any of the disclosed embodiments of the ‘510 patent and its internally-referenced patents limits the claimed diverter switch structure to any particular way of engaging the diverter shoes. See CX-1 (‘510 patent, cols. 6:13 (claim 1); 6:63 (claim 13); 7:46 (claim 23); 8:15-16 (claim 30); 9:1-3 (claim 42)). The disclosed embodiments use at least three different methods: (i) the “vertical,” electrically-controlled switch of the incorporated ‘912 patent, see CX-2 (‘912 patent, col. 1:65-68); (ii) the “horizontal,” pneumatically-controlled switch of the referenced ‘347 patent, see RX-333 (‘347 patent, col. 3:41-48); and (iii) the “black box” diverter switch of the incorporated ‘100 patent, which does not disclose the internal workings of the switch at all, see CX-3 (‘100 patent, col. 3:25-30).

To limit the “track means” element to any one way of “engaging,” and in particular to only the “vertical” way of engaging, would improperly import an unnecessary structure of only one embodiment into the claims, and at the same time would also improperly read out one or more of the other disclosed embodiments from coverage by the claims. See Wenger, supra, 239 F.3d at 1233 (“Under § 112, ¶ 6, a court may not import functional limitations that are not recited in the claim, or structural limitations from the written description that are unnecessary to perform the

claimed function.”); NeoMagic Corp. v. Trident Microsystems, Inc., 287 F.3d 1062, 1074 (Fed.Cir. 2002) (“It is elementary that a claim construction that excludes the preferred embodiment ‘is rarely, if ever correct and would require highly persuasive evidentiary support.’”).

It is true that “[a]n inventor may use the specification and prosecution history to define what his invention is and what it is not – particularly when distinguishing the invention over prior art. . . . Statements detailing the shortcomings of the relevant prior art have often proved useful in construing means-plus-function claims.” Ballard, supra. In Signtech, supra, the patentee, which had used means-plus-function claim format, noted in the specification that the structure used by certain prior art was “incapable” of achieving the desired results of the invention. The Federal Circuit held that statement to be an “explicit disavowal of prior art structure,” which was properly used in narrowly construing the means-plus-function claims to exclude that structure. Signtech, supra. However, the invention for which the ‘912 patentee specifically disavowed prior art horizontal diverter switches was only that of a vertical diverter switch (more specifically, as the claims of the ‘912 patent require, a “diverter means”), not of an entire conveyor system that comprises an improvement over prior art systems that included a “track means” encompassing both diagonal rails and a diverter switch, as well as equivalent structures to the disclosed “track means” that were known at the time of filing of the ‘510 patent application to perform the same functions. See Al-Site Corp. v. VSI Intern., Inc., 174 F.3d 1308, 1320 n.2 (Fed.Cir. 1999); Chiuminatta Concrete Concepts, Inc. v. Cardinal Industries, Inc.,

145 F.3d 1303, 1310-11 (Fed.Cir. 1998). To allow a disavowal of prior art diverter switches in connection with the much narrower invention of the '912 patent to swallow the scope of the clearly broader conveyor system invention of the '510 patent would, as the Staff observes, be illogical. It would also ignore both the Jepson claim structure of claims 1, 13 and 23 which identify the invention as an improvement over the prior art systems that use one of the disclosed "track means," as well as the preamble structure of claims 30 and 42 in which the "track means" may be read as not to constitute a limitation on the invention at all. See 3 Chisum § 8.06[1][c] and [d], supra.

Accordingly, the term "track means engaging said diverter shoes for imparting a lateral force to move said diverter shoes laterally to displace product positioned on said conveying surface" as used in claims 1, 13 and 23; and "track means extending below said uppermost ones of said slats for engaging and imparting a lateral force to displace selected ones of said diverter shoes laterally with respect to said conveying surface" as used in claims 30 and 42, are construed according to 35 U.S.C. § 112, ¶ 6 as "means plus function" elements to mean a guide track network that includes diverter switches and diagonal rails, the structures of which are disclosed in the '510 patent and in patents referenced therein, or their structural equivalents, that perform the claimed functions of "engaging" the diverter shoes (the function of the switches) and "imparting a lateral force" to move the diverter shoes (the function of the diagonal rails). In this regard, the diverter switches of the "track means" element can be any diverter switch known to persons of ordinary skill in the

art at the time of filing of the '510 patent application, and can include, inter alia, “vertical” switches, “horizontal” switches, electrically-controlled switches and pneumatically-controlled switches.

### 3. “A right cylinder” (Claim 1)

Rapistan contends that the element in claim 1 of “slats being defined by a wall formed as a right cylinder” includes surfaces generated by a straight line moving parallel to a fixed straight line and intersecting a plane curve at a right angle to the fixed straight line, with some minimal deviations. CIB 36. This shape, according to Rapistan, provides a generally closed loop structure to support the closed conveyor or support surface. Id. The description of the preferred embodiment, according to Rapistan, likewise describes the slat, shown in Figure 3 of the '510 patent, as a right cylinder. CIB 37. This embodiment includes a T-shaped projection 42 having certain cantilevered projections or flanges, and therefore, Rapistan argues, the claim term “right cylinder” must be interpreted to accommodate some degree of deviation from a mathematically precise right cylinder. CIB 37-38.

Vanderlande agrees that a cylinder is a surface traced by a straight line moving parallel to a fixed straight line and intersecting a fixed planar closed curve, and that right cylinder has a perpendicular axis joining the center point of the upper and lower bases. RIB 49. Vanderlande further argues, however, that the “fixed planar closed curve” of its right cylinder definition means “to have or take a turn, change, or deviation from a straight line or plane surface without sharp breaks or angularity.” RIB 49-50. “Closed” means “not open,” according to Vanderlande, and



therefore to be a “closed curve,” there can be no projections (either inward or outward). Id. Hence, for a slat to be a “right cylinder” according to Vanderlande, the walls that make up the slat must have no breaks or angularity and no projections, either internal or external. Id.

The Staff agrees with Rapistan and Vanderlande that a cylinder is a shape formed by the extension of a planar closed curve of any shape into the third dimension, and a right cylinder is one in which the extension into the third dimension is at a right angle to the planar curve. SIB 23. The closed curve that forms the cross section of a pure right cylinder, according to the Staff, must be a figure traceable from any starting point back to that point without any doubling back. Id. However, the Staff contends, the slat of the preferred embodiment of the ‘510 patent is not a pure right cylinder because of the T-shaped projection from the middle of the bottom of the slat, which results in wall segments that must be re-visited when one traces the center line of the slat wall. SIB 23-24. Accordingly, the Staff maintains, the term “right cylinder” as used in claim 1 should not be interpreted to require a pure right cylinder in the mathematical sense, but should be interpreted to encompass a slat with a cross-section having at least minor deviations from a pure closed curve. Id.

The shape of the cross-section of the slat of the preferred embodiment is portrayed in Figure 3 of the ‘510 patent as follows:

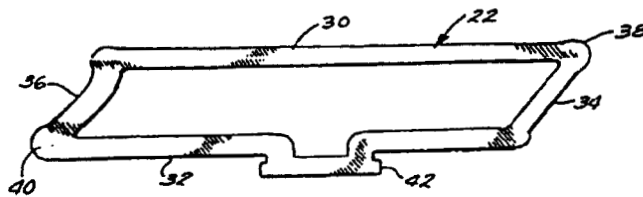

*Fig. 3.*

See CX-1 ('510 patent, Fig. 3); FF 121. Vanderlande's definitions of a "right cylinder" and a "closed curve" come from non-technical dictionary definitions. See RX-641 at 285 and 288. It is this dictionary definition of a "curve" that requires no "sharp breaks or angularity," not anything in the '510 patent. If this dictionary definition were adopted, then the embodiment shown in Figure 3, a parallelogram shape with well-defined angles, would be excluded from the "right cylinder" element of claim 1, an outcome that is, in the words of the Federal Circuit, "rarely, if ever, correct." See Vitronics Corp. v. Conceptor, Inc., 90 F.3d 1576, 1583-34 (Fed.Cir. 1996). It further shows the limitations of using non-technical dictionaries to construe claim terms, particularly in instances where the preferred embodiment would be excluded as a result. See Bell Atlantic Network Services, Inc. v. Covad Communications Group, Inc., 262 F.3d 1258, 1267 (Fed.Cir. 2001) ("[W]e have previously cautioned against the use of non-scientific dictionaries lest dictionary definitions be converted into technical terms of art having legal, not linguistic significance.") (internal quotes omitted).

The testimony of the experts of both Rapistan and Vanderlande also do not support Vanderlande's concept of a right cylinder. Rapistan's expert, Radcliffe, testified that with a right circular cylinder, in which the cross-sectional curve is a circle, even if the circle were distorted, pushed, or if a kink were put in it such that it is no longer a right circular cylinder, it remains a right cylinder. See Radcliffe Tr. 800:23-801:5; FF 122. Vanderlande's expert, Hoet, testified that there can be square cylinders. See Hoet Tr. 2026:6-9; FF 123. This testimony suggests that there can indeed be angularity to the closed curve that makes up the cross-section of a right cylinder.

Accordingly, in the term "slats being defined by a wall formed as a right cylinder" of claim 1, "right cylinder" is construed to mean a surface that is generated by a straight line moving parallel to a fixed straight line and intersecting a plane curve consisting of a generally closed loop at a right angle to the fixed straight line, with allowance for some minimal deviations, and such that there can be angularity in the curve.

**4. "An outer surface having a planar upper portion defining said conveying surface"/"A wall having generally planar upper and lower wall portions" (Claims 1, 13, 23)**

Rapistan contends that the term in claim 1 "an outer surface having a planar upper portion" and the term in claims 13 and 23 "a wall having generally planar upper and lower wall portions" includes surfaces forming an overall flat upper conveying surface that can include some raised surfaces that deviate from a true two-dimensional surface. CIB 36 and 38. These raised surfaces include raised, rounded

surfaces at the leading and trailing edges of the upper wall of the slat shown in Figure 3 of the '510 patent. CIB 39. Rapistan further contends that it is understood in the industry, and accepted by Vanderlande, that prior art devices, such as the CML sorter slat and the slat shown in Figure 14 of Vanderlande's design of its European patent application 0444734, are considered to have "flat" conveying surfaces even though both have substantial ridges on the slat's upper surface. CIB 40. Thus, according to Rapistan, wide latitude is to be applied to the requirement of a "planar upper portion" provided the combination of slats forming the conveyor surface collectively provides an essentially flat upper surface. CIB 40-41. Further, Rapistan argues, the term "generally planar" in claims 13 and 23 would accommodate still greater deviation from a mathematically precise two-dimensional surface. CRB 37.

Vanderlande disagrees with Rapistan that the "planar upper portion" of the slat can have deviations from a flat, two-dimensional surface. RIB 51. Rapistan's interpretation, according to Vanderlande, improperly adds the word "generally" before the word "planar" in claim 1 where it does not appear, whereas that term does appear in claims 13 and 23 ("generally planar upper and lower wall portions"). *Id.* According to Vanderlande, it is improper to read the limitations of one claim into another that does not contain the same limitation. *Id.* Vanderlande further argues that not all of the embodiments shown in the '510 patent have raised rounded corners like that shown in Figure 3; in Figure 10, the upper wall of the slat is perfectly flat. RRB 31.

---

The Staff agrees with Rapistan that “planar upper portion” should be interpreted to encompass surfaces with or without ridges that provide a flat conveying surface unlike that provided by tube-type sorters. SIB 25. The Staff disagrees with Vanderlande’s position that a person of ordinary skill in the art would understand “planar” as used in claim 1 to require a purely flat upper surface. SIB 24. The Staff points out that the upper surface of the slat of the preferred embodiment is not precisely flat because it has raised corners, such that at least some variation from a purely planar upper surface is contemplated by the claim language. *Id.* The Staff further points out that persons of ordinary skill in the art would be aware of two different types of positive sorters in the prior art, those with a closed-deck carrying surface defined by slats with a generally flat upper surface, and those with a carrying surface defined by cylindrical tubes with gaps between them. *Id.* The generally flat conveying surface, according to the Staff, is advantageous because the tube sorter has significant gaps between the tubes in which protrusions from conveyed parcels can become lodged, potentially causing the system to fail. *Id.* A planar upper portion of the slat provides a flat conveying surface and permits a broader range of material to be conveyed and sorted. SIB 25. Thus, the term “planar” would suggest to a person of ordinary skill in the art an attempt to draw a distinction between the claimed invention and prior art tube-type sorters. *Id.*

The only textual mention of this claim element in the written description of the ‘510 patent is in the section on the “Summary of the Invention,” which states that “[t]he invention is embodied in a sortation system in which each of the slats is

defined by a wall having a planar upper portion that defines the conveyor surface . . . .” CX-1 (‘510 patent, col. 1:56-58) (emphasis added); FF 124. The section on the “Description of the Preferred Embodiment” does not use such language, referring instead to the slat 22 as including only “an upper wall 30, a lower wall 32,” and such slat being “quadrilateral in cross-section in a manner which defines a parallelogram having parallel upper and lower walls . . . .” CX-1 (‘510 patent, col. 3:15-20). Also, Figure 3 of the ‘510 patent depicts a cross-section of the slat of the preferred embodiment as follows:

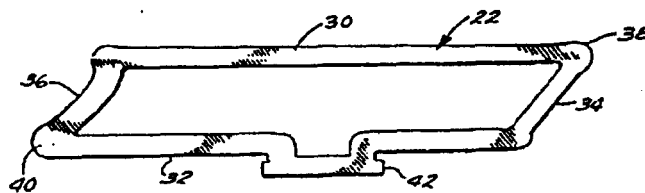

*Fig. 3.*

See CX-1 (‘510 patent, Fig. 3); FF 125. Upper wall 30 is described in the patent as joining forward wall 34 “at an enlarged radius corner 38.” See CX-1 (‘510 patent, col. 3:22-23); FF 126.

The parties make no reference to any portion of the prosecution history of the ‘510 patent in construing this claim term. Thus, having little intrinsic evidence to rely upon in construing this claim term, resort should be had to the extrinsic evidence of record. See *CCS Fitness, Inc. v. Brunswick Corp.*, 288 F.3d 1359, 1366 (Fed.Cir. 2002) (“Claim interpretation begins with an examination of the intrinsic evidence, *i.e.*, the claims, the rest of the specification and, if in evidence, the prosecution

history. [citations omitted]. Courts may also use extrinsic evidence (e.g., expert testimony, treatises) to resolve the scope and meaning of a claim term.”).

Vanderlande’s expert, Hoet, testified that the term “planar” is equated in engineering terms, “by and large,” with the term “flat,” and that a slight unevenness or slight variation would not affect the term “planar” in a surface. See Hoet Tr. 2006:4-9. Hoet further testified that upper surface 30 of the slat of the ‘510 patent as shown in cross-section in Figure 3 above deviates from “planar” because of the rounded corners at both ends of the upper surface. See Hoet Tr. 2006:10-19; FF 127. Also, Vanderlande’s Manager of Mechanical Development, van den Goor, characterized both the prior art CML sorter as “flat” and the upper conveying surface 86 of his own slat design shown in Figure 14 of Vanderlande’s European patent application 0444734 as being “flat, plate-shaped,” even though both surfaces have substantial ridges on them. See van den Goor Tr. 1546:10-13; RPX-9; RX-125 (EP ‘734 application, col. 11:28-29); FF 128. The “flat” CML conveying surface is depicted a the published French patent application as item 30 in Figure 9, as follows:

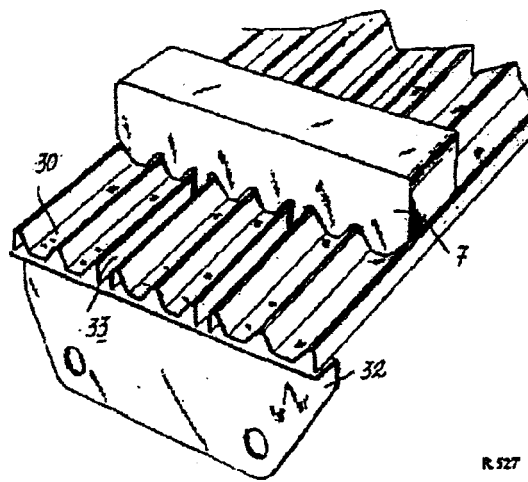

Fig. 9

R. 527

See Hoet Tr. 2109:14-16; RX-220 at R527; FF 129. The “flat, plate-shaped” conveying surface 86 of the slat and shoe combination shown in Figure 14 of the Vanderlande European patent application 0444734 is shown as follows:

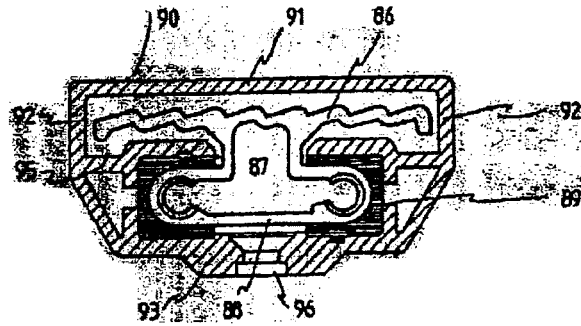

Fig 14

See RX-125; FF 130. As both figures demonstrate, the notion of a “flat” or “planar” conveying surface in the sortation industry tolerates a considerable degree of deviation from that of a perfectly flat, two-dimensional surface. The term “planar,” therefore, is “to be understood for what it meant to one having ordinary skill in the art at the time the application was filed.” *In re Koller*, 613 F.2d 819, 824 (CCPA 1977); accord, *U.S. Steel Corp. v. Phillips Petroleum Co.*, 865 F.2d 1247, 1251 (Fed.Cir. 1989); also see *Dow Chemical Co. v. Sumitomo Chemical Co., Ltd.*, 257 F.3d 1364, 1372 (Fed.Cir. 2001) (“Dow Chemical”) (“[A] technical term used in a patent claim is interpreted as having the meaning a person of ordinary skill in the field of the invention would understand it to mean.”).

Vanderlande points out, however, that the term “planar” in claim 1 is not modified by the adjective “generally” as it is in claims 13 and 23, and that this



intentional omission on the part of the claims drafter is significant. One cannot read the limitations of one claim into another that does not contain that limitation, Vanderlande contends. RIB 51, citing Grain Processing Corp. v. American Maize- Prods. Co., 840 F.2d 902, 911 (Fed.Cir. 1988); D.M.I., Inc. v. Deere & Co., 755 F.2d 1570, 1574 (Fed.Cir. 1985); RRB 32, citing Texas Instruments Inc. v. U.S.I.T.C., 988 F.2d 1165, 1171 (Fed.Cir. 1993); Intervet Am., Inc. v. Kee-Vet Labs., Inc., 887 F.2d 1050, 1054 (Fed.Cir. 1989); SRI Int'l. v. Matsushita Electric Corp., 775 F.2d 1107, 1122 (Fed.Cir. 1985).

The difference between “a planar upper portion defining said conveying surface” in claim 1 and “a wall having generally planar upper and lower wall portions” in claims 13 and 23 is readily explained, however, by the fact that claim 1 covers only the upper portion of the slat, whereas claims 13 and 23 cover both the upper and lower portions of the slat. As shown above in Figure 3 of the ‘510 patent, the lower wall portion of the slat deviates substantially from planar by virtue of its “T-shaped projection 42” that acts as the lateral stabilizing means of the shoe-and-slat combination. See CX-1 (‘510 patent, col. 4:53-61); **FF 131**. The term “generally” in claims 13 and 23 thus assures that the word “planar” covers both upper and lower wall portions. As the word “generally” is not used anywhere in the written description of the ‘510 patent in connection with the “planar” upper wall portion of the slat, there is no reason to attribute any more meaning to that term than the claims themselves imply. See Dow Chemical, supra, 257 F.3d at 1372 (“We look first to the claim language itself, to define the scope of the patented invention.”).

---

Accordingly, in the term “an outer surface having a planar upper portion” of claim 1, and in the term “a wall having generally planar upper and lower wall portions” in claims 13 and 23, “planar” is construed to mean an overall flat surface that can include some raised portions that deviate from a truly two-dimensional surface. The term “generally planar” in claims 13 and 23 cover “planar” surfaces on the upper and lower wall portions as well, but the term accommodates even more substantial deviations from the two-dimensional surface.

**5. “Support portion”/“Support member”/“Diverting member”/“Diverting portion” (Claims 1, 13, 20, 22, 23, 27, 29, 30, 33, 42, 45)**

Rapistan contends that the term “support portion” in claims 1, 13, 20, 22, 23, 27 and 29, and the term “support member” in claims 30, 33, 42 and 45, are to be construed equally as part of a device that holds up or serves as a foundation for another portion of the device. CIB 68. Rapistan also maintains that the term “diverting member” in claim 30 and “diverting portion” in claim 42 should also be construed equally to encompass a unitary forming of the diverting member with the support member as well as a support member that is physically separable from the diverting member. CIB 68-69; CRB 50-52. The word “portion,” Rapistan contends, encompasses a unitary forming of the support and diverting portions of the shoe. CIB 68-69. This is established, according to Rapistan, by the use of “portions” and “joining” elsewhere in the claims, such as claims 13, 23, and 29. *Id.* Where claims 13 and 23 claim “slats defined by a wall having generally planar upper and lower wall portions joined by sidewall portions,” the ‘510 patent discloses that the slat is

preferably extruded as an integral piece. *Id.* Thus, Rapistan reasons, “joined” must encompass such forming as an integral whole. CIB 70.

Vanderlande argues that the purpose of the “support member” is to provide contact surfaces that support the shoe on the slat while resisting reactive forces. RIB 40. Thus, the term “support member” and “support portion” require that the shoe have a support that surrounds the slat and provides support by contacting the top, bottom, and sides of the slat. RRB 22-23. Vanderlande also argues that the term “support member” in claims 30, 33, 42 and 45 require the “diverting member” to be a separate modular structure from the “support member.” RIB 60-62; RRB 45-46.<sup>3</sup> Vanderlande concedes, however, that the term “support portion” in claims 1, 13, 20, 22, 23, 27 and 29 does not require such two-piece construction. RRB 46.

According to the Staff, the term “support portion” in the context of claim 1 of the ‘510 patent does not require a separately manufactured component of the diverter shoe, and can be satisfied by either a one-piece shoe or a two-piece shoe. SIB 25-26, citing Rexnord Corp. v. Laitram Corp., 274 F.3d 1336 (Fed.Cir. 2001). Likewise, the Staff contends that the terms “diverting member”/“diverting portion” and “support member” in claims 30, 33, 42 and 45 should also be read to encompass both a unitary as well as a two-piece shoe. SIB 45-46.<sup>4</sup>

---

<sup>3</sup>Although Vanderlande makes reference in its briefs only to the use of the term “support member” in independent claims 30 and 42, it is assumed that the same arguments apply to claims 33 and 45 that depend from independent claims 30 and 42, respectively.

<sup>4</sup>As with Vanderlande’s contentions, it is presumed that the Staff’s references only to the “support member” term in claim 30 is intended to refer to independent  
(continued...)

---

Independent claims 1, 13, and 23 refer to “each of said diverter shoes having a support portion.” See CX-1 (‘510 patent, cols. 6:21 (claim 1), 7:3 (claim 13), 7:54 (claim 23)). Asserted dependent claims 20, 22, 27 and 29 refer back to the “support portion” element of the foregoing corresponding independent claims. See CX-1 (‘510 patent, cols. 7:34 (claim 20), 7:38 (claim 22), 8:4 (claim 27) and 8:8 (claim 29)). In non-asserted claim 9 depending from claim 1, “each of said diverter shoes further includes a diverting portion joined to said support portion.” See CX-1 (‘510 patent, col. 6:44-46). In non-asserted claim 12 depending from claim 9, “said diverting portion is joined to said support portion by a dovetail groove.” See CX-1 (‘510 patent, col. 6:54-56).

Similarly, independent claims 30 and 42 each have elements consisting of “a support member” and “a diverting member” (in the case of claim 30) or “a diverting portion” (in the case of claim 42). See CX-1 (‘510 patent, cols. 8:19 and 22 (claim 30) and 9:6 and 9 (claim 42)). Asserted dependent claims 33 and 45 refer back to the “support member” element of the foregoing corresponding independent claims. See CX-1 (‘510 patent, cols. 8:38-39 (claim 33) and 9:19-20 (claim 45)). In non-asserted claim 40 depending from claim 30 and non-asserted claim 50 depending from claim 42, “said diverting member is joined to said support member by a dove-tail joint.” See CX-1 (‘510 patent, cols. 8:60-62 and 10:17-19).

The specification of the ‘510 patent never refers to a “diverting portion” and refers to a “support portion” only once, in the “Summary of the Invention,” where the

---

<sup>4</sup>(...continued)  
claim 42 and dependent claims 33 and 45.

invention is described as having, inter alia, “diverter shoes having a support portion . . . .” See CX-1 (‘510 patent, col. 1:59-60). All other references in the specification are to a “diverting member” and a “support member.” See, e.g., CX-1 (‘510 patent, cols. 2:11, 2:14-15, 2:27-28, 3:26-27, 3:28, 3:66-68, 4:1, 4:27, 4:34-35, 4:40, 4:43-44, 4:51). The ‘510 patent provides no intrinsic explanation for the difference in the claim language between “support portion” and “support member” on the one hand and “diverting portion” and “diverting member” on the other hand.

The parties do not dispute that the term “support portion” encompasses a diverter shoe consisting of both (i) a one-piece shoe having both a support structure and a diverter structure that are physically integrated with one another, and (ii) a two-piece shoe having a support structure that is physically separate from the diverter structure, but joined together. CRB 30; RRB 45-46; SIB 25-26. Indeed, the Staff points out that the word “portion” has been construed specifically by the courts as not requiring a separate component as opposed to part of an integral whole. See SIB 26, citing Rexnord Corp. v. Laitram Corp., 274 F.3d 1336, 1343-48 (Fed.Cir. 2001). The parties differ only in connection with the terms “support member” and “diverting member”/“diverting portion,” with Vanderlande alleging, contrary to Rapistan, that these terms encompass only a two-piece diverter shoe, not a one-piece shoe. CRB 30; RRB 45-46.

Unlike the independent “support portion” claims 1, 13 and 23 that are directed toward an overall “conveying system” and make no specific reference to the

diverting portion of the shoe,<sup>5</sup> the independent “support member”/“diverting member”/“diverting portion” claims 30 and 42 are directed specifically to “a diverter shoe for use in a conveyor system” and include as an element “a diverting member joined to said support member.” See CX-1 (‘510 patent, cols. 8:10 and 22 (claim 30) and 8:65 and 9:9 (claim 42)). The only perceptible reason for the differing language, therefore, is that the latter claims include as an element the “diverting member”/“diverting portion” that is not a claimed feature of the former claims. There is no evidence to suggest that the term “member” is supposed to refer only to a two-piece shoe while “portion” can encompass either a one-piece shoe or a two-piece shoe. It is true, as Vanderlande argues, that the specification of the ‘510 patent does not show any embodiment where the “support member” and “diverting member” are formed as a single integral unit. RIB 60. However, the scope of these claim terms is not limited to the embodiments disclosed in the ‘510 patent. Teleflex, Inc. v. Ficosa North America Corp., \_\_\_ F.3d \_\_\_, 2002 WL 1358720 at \*10 (Fed.Cir. 2002) (“We have cautioned against limiting the claimed invention to preferred embodiments or specific examples in the specification.”) (internal quotation marks omitted).

---

<sup>5</sup>Only claim 9, which depends from claim 1, recites that “each of said diverter shoes further includes a diverting portion joined to said support portion.” See CX-1 (‘510 patent, col. 6:44-46) (emphasis added). The word “further” makes clear that the “diverting portion” is an additional feature in claim 9 that does not appear in claim 1. See 2 P. Rosenberg, Patent Law Fundamentals § 14.08, at 14-52 (1999 Rev.) (“Where the dependent claim adds an element of structure (whether a means or a step), its transitional phrase is usually preceded by the word ‘further’ (e.g., ‘The apparatus according to claim 1 further comprising . . . ’).”) (emphasis in original).

The use of the word “joined” in juxtaposition with the foregoing terms in various claims, such as in “a diverting portion joined to said support portion” in claim 9 and “a diverting member joined to said support member” in claim 30, does not alter the analysis. In the first place, there is no evidence that the ordinary meaning of the word “joined” implies any particular method of connection between the “support portion” and the “diverting portion.” Cf. Certain Personal Watercraft and Components Thereof, Inv. No. 337-TA-452, Order No. 32 at 17, 2001 WL 1646160 (U.S.I.T.C., August 14, 2001) (“Neither party points to any ordinary or customary definition of these terms [“assembly” and “joined”] that would require a cover and ventilation assembly to have members that are joined by mechanical fasteners, nor do they point to any definition that would preclude such an assembly from being joined by adhesive bonding.”). In the second place, the specification of the ‘510 patent describes the invention as “further provid[ing] modular diverter shoes having interchangeable upper diverting portions for use with right-handed, left-handed and bi-directional divert systems . . . .” Sec CX-1 (‘510 patent, col. 1:50-53). However, the modularity and interchangeability of the upper diverting portions is not an element of any claim of the ‘510 patent except in one respect – that in dependent claims 12, 40 and 50, the diverting portion or member is joined to the support portion or member by a “dovetail groove” or “dove-tail joint.” See CX-1 (‘510 patent, cols. 6:54-56 (claim 12), 8:60-62 (claim 40) and 10:17-19 (claim 50)). Such a groove or joint could not be used unless the support and diverter portions were modular in relation to one another. That implicit limitation in claims 12, 40 and 50, however,

cannot be read into the preceding claims from which they depend. See Intervet America, Inc. v. Kee-Vet Laboratories, Inc., 887 F.2d 1050, 1054 (Fed.Cir. 1989) (holding that it was reversible error to import a limitation from one claim into a second claim); SRI Intern. v. Matsushita Elec. Corp. of America, 775 F.2d 1107, 1122 (Fed.Cir. 1985) (“It is settled law that when a patent claim does not contain a certain limitation and another claim does, that limitation cannot be read into the former claim in determining either validity or infringement.”).

Accordingly, the term “support portion” in claims 1, 13, 20, 22, 23, 27 and 29, and the terms “support member,” “diverting member” and “diverting portion” in claims 30, 33, 42 and 45, are to be construed equally to encompass a support foundation and a diverting portion made up of either a single, integrated support and diverter structure or a modular, two-piece support structure joined to a diverter structure.

**6. “Glide surface” (Claims 1, 13, 17, 23) and “glide portion including means defining a glide surface adapted to glide along one of said slats” (Claims 30, 42)**

According to Rapistan, the claim term “glide surface” as used in claims 1, 13, 17, 23, 30 and 42 refers to the inner portion of the diverter shoe’s support portion that consists of a surface that moves over or along the surface of the slat without pivoting or rolling. CIB 49; CRB 22. A “substantially continuous glide surface,” according to Rapistan, is a glide surface that extends from one location or end of the glide surface to the other end without a substantial break. Id. Such a surface, Rapistan



further maintains, may or may not incorporate regions of contact or non-contact with the slat. Id. at 50.

Rapistan also argues that the term “glide portion including means defining a glide surface adapted to glide along one of said slats” as used in claims 30 and 42 is interpreted in accordance with the “means plus function” provisions of 35 U.S.C. § 112, ¶ 6 to mean the performance of the function of defining a glide surface adapted to glide along one of said slats by the corresponding structure disclosed in the ‘510 patent including a plurality of walls or wall segments that establish a glide surface relative to a slat, or its structural equivalent. CIB 55. However, Rapistan also argues that the required structure does not include a surface that surrounds the slat, a surface substantially the same configuration as the slat, a channel, two enlarged radius corners and two small radius corners, and a support rib. CRB 27.

Vanderlande argues that the claim term “glide surface” is a low friction surface that contacts an opposing surface to reduce friction to facilitate movement. RIB 30. Vanderlande argues, unlike Rapistan, that this term requires there to be contact between the glide surface of the support portion of the diverter shoe and the opposing slat surface. See id. at 31-32. More particularly, the term “glide surface” in context with the immediately following claim term “surrounding said wall” requires the low-friction surface of the support portion of the diverter shoe to contact the top, bottom, and side walls of the slat. Id. at 32. Vanderlande analogizes the term to a metal button attached to the bottom of a furniture leg to provide a low-friction contact surface between an object above the glide, such as the furniture leg, and an

opposing surface, such as a floor, in order to facilitate the movement of the object relative to the opposing surface. See id. at 30.

Vanderlande takes issue with Rapistan's contention that the corresponding structure for the "means plus function" element of "a glide portion including means defining a glide surface adapted to glide along one of said slats" in claims 30 and 42 is merely a plurality of walls or segments. RRB 21. Vanderlande agrees with the Staff's interpretation of this element (described below) in which the specific structure detailed in the written description of the '510 patent is incorporated into this element. RRB 20-21.

The Staff maintains that the term "glide surface" encompasses both contact and non-contact surfaces, as Rapistan maintains. SIB 29. According to the Staff, the contact surfaces enable the shoe to resist reaction forces and glide along the slat, whereas the non-contact surfaces provide structural integrity and connect the contact surfaces with the remainder of the diverter shoe. Id. The Staff points out, however, that not every combination of contact and non-contact surfaces necessarily qualifies as a "glide surface." Id. at 30. If the inner surface of a shoe, no matter how it is configured, were in all cases a "glide surface," the Staff argues, then the significance of the word "glide" would be eliminated and the term "glide surface" would reduce to "inner surface" or just "surface." Id. Thus, according to the Staff and consistent with Vanderlande's position, the "glide surface" limitation of claim 1 "requires a shoe having an interior surface that can be viewed as a single, unitary structure, shaped in such a way so as to make contact with the slat at one or more points so as

to allow the shoe to slide easily along the slat while resisting reactionary forces.” *Id.*;  
SRB 8-9.

The Staff also maintains that the term “glide portion including means defining a glide surface adapted to glide along one of said slats” in claims 30 and 42 invokes the “means plus function” provisions of 35 U.S.C. § 112, ¶ 6. SIB 44. Therefore, the Staff argues, consistent with the preferred embodiment of the invention that is disclosed in the written description of the ‘510 patent, this element “requires a substantially continuous surface that surrounds and has substantially the same configuration as the slat, with the slat having a roughly parallelogram-shaped cross-section, and contact points between the shoe and slat at diagonally opposite enlarged radius corners of the slat,” or an equivalent structure. SIB 45. The Staff disagrees with Rapistan’s contention that the structure corresponding to this element is merely a plurality of walls or segments. SRB 17-18.

The experts of both Rapistan and Vanderlande agree that the term “glide surface” in the ‘510 patent distinguishes this element from a device that rolls or makes rolling contact with another object such as the slat. CIB 52; CRB 23; Hoet, Tr. 1972:7-9, 15-17, 1973:20-1974:13; Cotter Tr. 659:1-3, 676:22-25; van den Goor Tr. 1714:3-7; Radcliffe, Tr. 1355:9-12, 2207-17-2208-22, 2211:4-2212:17, 2221:1-2222:16; **FF 132**. The difference between a “glide surface” in the ‘510 patent and wheels or rollers is, therefore, undisputed.

All parties also agree that the “glide portion including means defining a glide surface adapted to glide along one of said slats” limitation of claims 30 and 42 is a

“means plus function” element that invokes the provisions of 35 U.S.C. § 112, ¶ 6. CIB 55; SIB 44; RRB 20. Therefore, for purposes of literal infringement, this limitation requires an accused device to perform the identical function identified in the means clause using structure that is the same as or equivalent to that disclosed in the specification. See Serrano v. Telular Corp., *supra*, 111 F.3d at 1582.

Vanderlande bases its interpretation of “glide surface” on what it considers to be its ordinary meaning. RIB 30. Rapistan and the Staff, however, do not agree that the term as a whole has an ordinary meaning either in the industry or in general usage. See CIB 51; SIB 28. All parties point to only one passage in the written description of the ‘510 patent that utilizes the term. That passage makes reference to the following Figures 2, 8 and 9 of the patent:

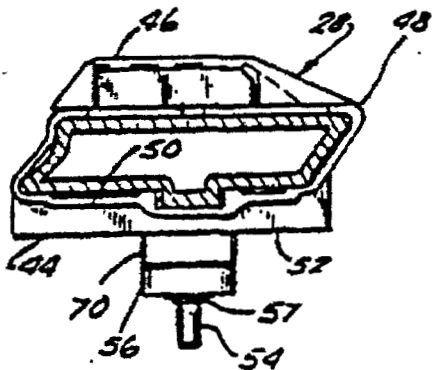

Part of Fig. 2

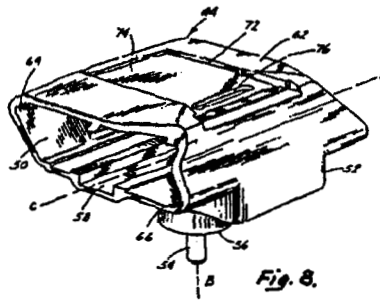

Fig. 8

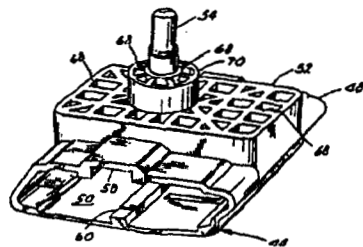

Fig. 9

Fig. 9

See CX-1 ('510 patent, Figs. 1, 8 and 9). The passage reads as follows, with relevant portions in italics for emphasis:

Support member 44 includes a glide portion 48 having a *continuous* glide surface 50 having *substantially the same configuration as the outer surface of slat 22 for gliding movement along the slat . . . .* Continuous surface 50 *includes* a channel 58 surrounding projection 42 of the slat such that the projection rides within the channel (FIGS. 8, 9 and 11). Continuous surface 50 *additionally includes* a support rib 60 which engages top wall 30 of the slat to support an upper wall 62 of the support member. Continuous surface 50 *additionally includes* an enlarged radius forward upper corner 64 and an enlarged radius lower

rear corner 66, in which enlarged radius corners 38 and 40 of the slat, respectively, ride. *This arrangement provides bearing engagement* between the enlarged radius corners of the slat and the corresponding corners of surface 50 to resist reaction forces tending to rotate the shoes about the axis of elongation of the slat.

CX-1 ('510 patent, col. 3:28-51) (emphasis added); CIB 50-51; RIB 32-33; SIB 29.

One characteristic of the “glide surface” of the preferred embodiment, as described in the foregoing passage, is that it is “continuous.” Another characteristic is that its configuration is “substantially the same” as the outer surface of the slat. These characteristics of a “glide surface” are imported from the written description directly into claim 1. See CX-1 ('510 patent, col. 6:22-25). The remaining characteristics of the “glide surface” that are mentioned in the foregoing passage have to do with points of contact, and are described as things that the glide surface “includes,” such as “channel” 58, “support rib” 60, “enlarged radius forward upper corner” 64 and “enlarged radius lower rear corner” 66. They do not specifically appear in claim 1, however. CRB 19; Hoet Tr. 1991:18-22. Of these features, the “enlarged radius forward upper corner” and “enlarged radius lower rear corner” are embraced by the “bearing means” element of claim 13, which is separate from the “glide surface” element of that claim as will be seen later herein. See id. (col. 7:5). Similarly, in claim 17 (which depends from claim 13) and independent claim 23, the “means defining lateral stabilizing means” embracing “channel 58” is a separate element from the glide surface element. See id. (col. 7:21 and 55).

Claims 30 and 42, unlike the other claims in which “glide surface” appears, require as an element “means defining a glide surface adapted to glide along one of said slats.” See CX-1 (‘510 patent, cols. 8:20-21 and 9:7-8). By using the word “means” in connection with the “defining” function, these claim elements invoke the provisions of 35 U.S.C. § 112, ¶ 6 whereby the function identified in the means clause is performed using structure that is the same as or equivalent to that disclosed in the specification. See Serrano v. Telular Corp., *supra*, 111 F.3d at 1582. Thus, in distinct contrast to the general rule that particular embodiments in the specification are not read into claim limitations, “means plus function” claim limitations are construed according to “[d]isclosed structure” and “any alternative structures identified.” *Id.*, 111 F.3d at 1583.

The varied wordings of claims 1, 13, 17, 23, 30 and 42 suggest that each is intended to cover a different aspect of the “glide surface” of the invention. Claim 1 encompasses the inventive “configurational” aspect of the glide surface, whereas claim 13 encompasses its inventive “bearing engagement” feature and claims 17 and 23 encompass the “means defining lateral stabilizing means” feature. The latter two features are among several points of contact that are “included” in “continuous surface 50” of the preferred embodiment as described in the passage from the written specification quoted above. However, they play no part in the “glide surface” element of claim 1. See SRI International v. Matsushita Electric Corp. of America, 775 F.2d 1107, 1122 (Fed.Cir. 1985) (“[It] is settled law that when a patent claim

does not contain a certain limitation and another claim does, that limitation cannot be read into the former claim in determining either validity or infringement.”).

The fact that the embodiment disclosed in the '510 patent shows points of contact between the glide surface and the slat does not mean that points of contact must necessarily be incorporated into every relevant claim through the “glide surface” element. The embodiment can disclose features that are not claimed; thus, claim 1 can encompass only certain features of the disclosed embodiment and not others that are encompassed in claims 13, 17 and 23, and vice versa. This is particularly so because claims 1, 13, 17 (through claim 13 from which it depends) and 23 all use the word “comprises” in the preamble of each claim, and therefore constitute “open-ended” claims that create “a presumption that the recited elements are only a part of the device, [and] that the claim does not exclude additional, unrecited elements.” Crystal Semiconductor Corp. v. TriTech Microelectronics Intern., Inc., 246 F.3d 1336, 1348 (Fed.Cir. 2001).

Claims 30 and 42, unlike claims 1, 13, 17 and 23, represent a combination of all of the foregoing features of the preferred embodiment into a single “means” element. None of the “configurational” or “contact point” structures of the invention are specifically mentioned in these claims, as they are in claims 1, 13, 17 and 23. Instead, by using the words “means defining a glide surface adapted to glide along one of said slats,” claims 30 and 42 combine the “configuration” of the disclosed embodiment with the structures encompassed by the “bearing means” and the “lateral



stabilizing means” in order to “adapt” the glide surface to the claimed function of “glid[ing] along one of said slats.”

The specific structure of the preferred embodiment is disclosed in the written specification as follows:

The invention is embodied in a sortation system in which each of the slats is defined by a wall having a planar upper portion that defines the conveyor surface in combination with diverter shoes having a support portion including a substantially continuous glide surface that surrounds the slat and has substantially the same configuration as the outer surface of the slat. In a preferred embodiment, the slat has a parallelogram cross-section and bearing means are defined between at least one edge of each slat and an engaging portion of the glide surface of the diverter shoe. The bearing means is provided by an enlarged radius surface at the slat edge. Such bearing means are preferable [sic] provided at diagonally opposite slat edges in order to better resist reaction forces about the axis of the slat.

SIB 44-45; CX-1 (‘510 patent, col. 1:56 - 2:2) (emphasis added). These underscored structural elements, or their structural equivalents, must be found in the “means defining a glide surface adapted to glide along one of said slats” in order to satisfy the requirements of 35 U.S.C. § 112, ¶ 6.

Where a claim term has a clear and well-defined meaning, extraneous limitations from the written description should not be read into the claim term in order to narrow that meaning. See Teleflex, Inc. v. Ficosa North America, 299 F.3d 1313, 1328 (Fed.Cir. 2002) (“Teleflex”) (where “record is devoid of ‘clear statements of scope’ limiting the term appearing in [the claim], we are constrained to follow the language of the claims, rather than that of the written description.”);

Comark, supra (“In this case, the term ‘video delay circuit’ has a clear and well-defined meaning. This term is not so amorphous that one of skill in the art can only reconcile the claim language with the inventor’s disclosure by recourse to the specification. See E.I. du Pont de Nemours, 849 F.2d at 1433 (stating that the specification can supply understanding of unclear terms, but should never trump the clear meaning of the claim terms).”). Although Vanderlande argues that “glide surface” has such a “clear and well-defined” ordinary meaning that resort to the ‘510 patent’s written description for further guidance is unnecessary (RIB 30), both Rapistan and the Staff disagree. CIB 51; SIB 28.

In support of its argument, Vanderlande relies upon dictionary definitions of the word “glide” as a noun, whereas Rapistan and the Staff point to dictionary definitions of the verb form. CIB 51-52 (referring to CX-660 and CX-661); RIB 30 (referring to RX-641); SIB 28 (referring to CX-660 and CX-661). Both the noun and the verb forms of the word “glide” have aspects that are relevant to the claim element in question. One dictionary definition of the noun form advocated by Vanderlande suggests “a device for facilitating movement of something,” such as the furniture glide that was introduced into the record. See RX-641; also see RPX-40; Tr. 1771; FF 133. The verb form advocated by Rapistan suggests moving “in a smooth, effortless manner” (CX-660) and “moving smoothly, continuously, and effortlessly” (CX-661); FF 134.

However, as the Staff points out, the word “glide” does not stand alone in the claims, but is linked as an adjective to the word “surface.” SIB 28. Consequently, the

complete term “glide surface” does not necessarily connote an object that is exactly the same thing as an object that one would refer to by the single word “glide.” The word “surface,” like the word “glide,” is susceptible to many different meanings, including in its noun form “the exterior or upper boundary of an object or body” and “a plane or curved two-dimensional locus of points (as the boundary of a three-dimensional region) . . . .” See Webster’s New Collegiate Dictionary 1163 (1979) (definitions 1 and 2 of “surface”). A “surface” may have a configuration or shape to it, as required by claim 1, or it may have portions that contact other surfaces, as required by claims 13 and 23. Both aspects are relevant in different ways to a surface’s “gliding” quality of moving smoothly and effortlessly in relation to another surface, and those differences are attributed to the invention by separate claims 1, 13 and 23 that have different wordings.

Thus, the term “glide surface,” rather than representing a definite structure, is a more abstract concept that takes on different characteristics of the invention in each of the foregoing claims. Rather than being a term that has “ordinary meaning” to one of skill in the art, “glide surface” is more a creation of the inventors in their role as “lexicographers” of the language of the ‘510 patent. See Trintec Industries, Inc. v. Top-U.S.A. Corp., 295 F.3d 1292, 1294-95 (Fed.Cir. 2002) (“Trintec”) (“As a general rule, claim language carries the ordinary meaning of the words in their normal usage in the field of invention. [citation omitted]. Nevertheless, the inventor may act as his own lexicographer and use the specification to supply implicitly or explicitly new meanings for terms.”).

The term “glide surface,” taking both words together, does not possess an ordinary meaning as a whole that conjures up any particular object or structure, and there is no evidence that the term would do so for a person of ordinary skill in the relevant art. Thus, Vanderlande’s effort to attribute to the term “glide surface” the ordinary dictionary definition of the word “glide” alone is misplaced. See, e.g., RRB 15. Vanderlande did not present any evidence outside of the dictionary definition of the word “glide” to show that “glide surface” has an ordinary meaning in the material handling industry or in the sortation industry. CRB 21. By contrast, Rapistan demonstrated, through its expert witnesses having personal experience in the material handling and diverter sortation field, that “glide surface” does not have an ordinary meaning, and the Staff agreed with this view. CRB 22; SIB 28; Woltjer Tr. 324:1-6, 413:25-414:2; Cotter Tr. 555:23-556:2; Radcliffe Tr. 1051:10-19.

As a result, we are permitted to look to the written description of the ‘510 patent in order to interpret the claim term “glide surface” in order “to determine if the patentee has limited the scope of the claims” in connection with this term. See Teleflex, supra, 299 F.3d at 1325; Trintec, supra. In this instance, the patentee did not limit the scope of the claim term “glide surface” by “including in the specification expressions of manifest exclusion or restriction, representing a clear disavowal of claim scope,” see Teleflex, supra, 299 F.3d at 1325. Rather, the patentee did restrict the scope of the claims themselves by including in each claim different language that limited one claim to the “configurational” aspects of the invention (i.e., claim 1), other claims to the “contact point” aspects of the invention

(i.e., claims 13, 17 and 23), and still other claims to a combination of the specific structures or structural equivalents that are disclosed in the written description of the '510 patent, in accordance with 35 U.S.C. § 112, ¶ 6 (i.e., claims 30 and 42).

If the claim term “glide surface” were interpreted to encompass within itself points of contact as Vanderlande and the Staff say it does, then the separate “bearing means” element of claim 13 and the separate “means defining lateral stabilizing means” of claims 17 and 23 would be superfluous because they denote specific kinds of contact points. See CRB 20-21; also see SRI International v. Matsushita Electric Corp. of America, 775 F.2d 1107, 1121 (Fed. Cir. 1985) (“[I]f everything in the specification were required to be read into the claims, or if structural claims were to be limited to devices operated precisely as a specification-described embodiment is operated, there would be no need for claims.”). Furthermore, that reading would violate the doctrine of claim differentiation, according to the Federal Circuit:

While we recognize that the doctrine of claim differentiation is not a hard and fast rule of construction, it does create a presumption that each claim in a patent has a different scope. “There is presumed to be a difference in meaning and scope when different words or phrases are used in separate claims. To the extent that the absence of such difference in meaning and scope would make a claim superfluous, the doctrine of claim differentiation states the presumption that the difference between claims is significant.”

Comark Communications, Inc. v. Harris Corp., 156 F.3d 1182, 1187 (Fed.Cir. 1998)

(“Comark”), quoting Tandon Corp. v. United States International Trade Commission,

831 F.2d 1017, 1023 (Fed.Cir.1987).

In countering this view, Vanderlande refers to an imaginary variant of a diverter shoe and slat that, according to its claim construction, has a “glide surface

surrounding said wall” but does not satisfy the specific contact locations of claims 13 and 23, as follows:

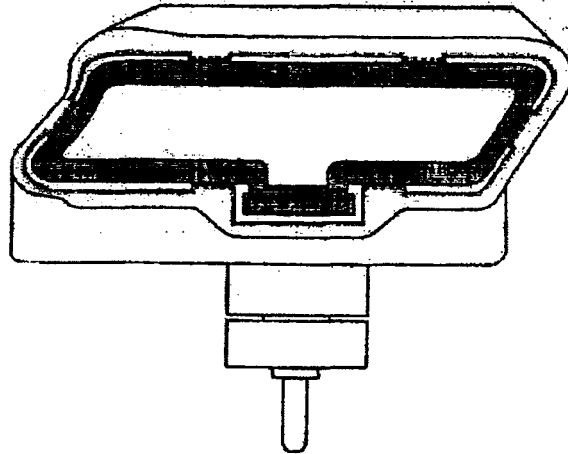

See RDX-73. Accordingly, Vanderlande contends, “the fact that Claims 13 and 23 relate to very specific locations for contact as found in the preferred embodiment of the ‘510 patent, does not compel under the doctrine of claim differentiation construing ‘glide surface’ as not requiring contact with the slat.” RRB 18.

It is unremarkable that the foregoing shoe and slat combination can be imagined that would design around Vanderlande’s claim construction. It simply shows that if Vanderlande’s claim construction were correct, it nevertheless would be possible to construct a non-infringing device. That does not prove, however, that the doctrine of claim differentiation is inapplicable here or that Vanderlande’s claim construction of the ‘510 is correct. The distinctions among claims must be made on the basis of what is shown in the patent and the recognized canons of claim construction, not on the basis of what can be imagined among the universe of possibilities. See Markman, supra. In any event, Vanderlande’s construct would

satisfy the claim term “glide surface” even if that term were construed not to require contact with the slat, so it is not clear how, if at all, it proves Vanderlande’s contention that the “glide surface” of the claimed invention must be in contact with the slat on all sides.

Vanderlande seeks further support for its interpretation of “glide surface” in an argument that Rapistan made in 1993 to the European Patent Office (“EPO”) during prosecution of the EPO counterpart application to the ‘510 patent (“the EP ‘150 application”). Statements made to foreign patent offices can be useful for claim construction purposes. See, e.g., Intellectual Property Development, Inc. v. UA-Columbia Cablevision of Westchester, Inc., 2002 WL 10479 (S.D.N.Y. 2002) (“Although varying legal and procedural requirements for obtaining patent protection in foreign countries might render consideration of certain types of representations inappropriate, instructions to foreign counsel and representations to foreign patent offices must be considered when such matters comprise relevant evidence.”).

Claim 1 of the EP ‘150 application paralleled claim 1 of the ‘510 patent in the U.S. using the following language:

[E]ach of the slats (22) is defined by a wall formed as a cylinder including an outer surface having a planar upper portion (3) defining the conveying surface, and each of the diverter shoes (28) has a support portion (44), including a substantially continuous glide surface (50) surrounding the said wall, the glide surface having substantially the same configuration as the outer surface of the slat.

See RX-126 (EP ‘150 application, col. 7:10-18); FF 135. The EPO rejected claim 1 in view of a Vanderlande published EPO patent application (“the EPO ‘734 application”) showing a design that, under the laws of the EPO, was “prior art” to

Rapistan's EPO application. The Vanderlande shoe-and-slat design in question was depicted in Figure 14 of the EPO '734 application as follows:

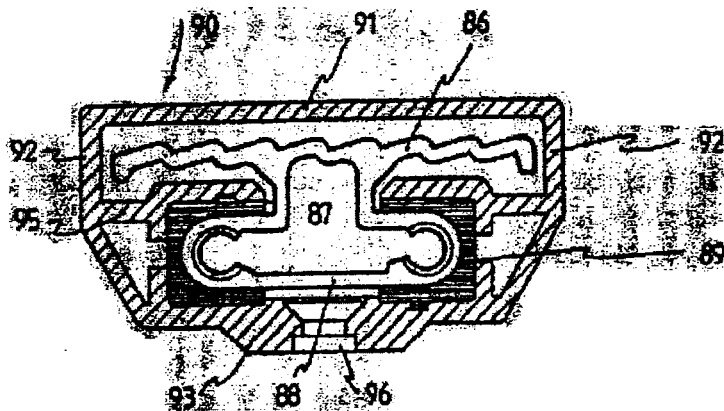

Fig 14

See RX-125; FF 136. In its rejection, the EPO likened the “wall formed as a cylinder including an outer surface having a planar upper portion (3)” of Rapistan’s claim 1 to item 86 of Figure 14, and the “substantially continuous glide surface (50) surrounding the said wall, the glide surface having substantially the same configuration as the outer surface of the slat” of Rapistan’s claim 1 to skids identified as item 89 in Figure 14. See RX-127 at R11634; FF 137.

In response to the EPO rejection, Rapistan argued as follows:

In Claim 1 of the present application, the slat is defined by a wall which has an upper portion defining the conveying surface, and the wall is surrounded by a glide surface of the diverter shoe. This does not appear to be the case in EP 0444734. In annex 1 of the official communication, the Examiner indicated that the planar upper portion (86) of Figure 14 of EP 0444734, as part of the wall, is surrounded by the skids (89), but this does not appear to be the case, because the planar upper portion (86) is above the skids.

See RX-128 at R11625; FF 138.



According to Vanderlande, the distinction that Rapistan made between its claim and the design of Figure 14 is that the diverter shoe of that design did not feature “a glide surface surrounding said wall” because the shoe did not contact the top conveying surface 86. RIB 35. According to the Staff, the fact that the EPO equated the skids of Figure 14 with the “glide surface” of claim 1 and ignored the remaining non-contact portions of the diverter shoe’s inner surface, together with the fact that Rapistan did not dispute that characterization and instead argued that the skids do not surround the slat, are evidence that the “glide surface” connotes something more than just the interior surface of the shoe, and that the structure of the contact surfaces of the skids distinguishes them from the claimed “glide surface.” SIB 31-32.

It is true as the Staff contends that the EPO equated the “glide surface (50)” of claim 1 of the EPO ‘150 application to the skids 89 of Figure 14, but the differing interpretations that Vanderlande and the Staff place on Rapistan’s response to the rejection do not put in full context the sparse statements of Rapistan’s counterargument to the EPO that each of the foregoing features of claim 1 of the ‘150 application “does not appear to be the case” in the Vanderlande design. The Vanderlande design of Figure 14 cannot be divorced from the written description of its structure that appears in the text of the EPO ‘734 application as follows:

Figure 14 shows an embodiment of a carrier comprising a flat, plate-shaped upper side 86, which is coupled, by means of two legs 87 extending downwards from said upper side, to a double-walled section part 88 having rounded corners, which extends parallel to the plate-shaped upper side. Complementarily shaped skids 89 of plastic material or the like are provided around the ends of the section part

88, said skids functioning to support a pusher shoe 90 which is movable in the longitudinal direction of the carrier illustrated in sectional view in Figure 14. Said pusher shoe is provided with a pusher part 91 extending above the plate-shaped upper side 86 of the carrier, the ends of said arms, which slope downwards in a direction towards each other, being interconnected by means of a connecting plate 93. The skids 89 are thereby confined, in the manner illustrated in Figure 14, between said connecting plate 93 and supporting arms 95 located between the pusher plate 91 and the connecting plate 93. In the connecting plate there is furthermore provided a hole 96 for a guide means to be mounted therein.

RX-125 (EPO '734 application, at col. 11:28-53) (emphasis added); FF 139. As the underscored language indicates, the “complimentarily shaped skids 89” of Figure 14 are plastic parts that are separate and apart from both the pusher shoe 90 and the unlabelled “slat” that is made up of components 86, 87 and 88. By contrast, the separate “skids 89” are “confined” by “connecting plate 93” and “supporting arms 95” that are integral components of the surrounding wall of pusher shoe 90.<sup>6</sup>

The EPO's rejection of claim 1 of Rapistan's '150 application does not mention the word “skid” anywhere. Accordingly, Rapistan must have picked the word up from the written description of the '734 application when it argued against the rejection. Thus, taking Figure 14 of the '734 application in context with the text of the '734 application, as Rapistan presumably did in making its counterargument to the EPO, “skids 89” are exactly what they are depicted to be in Figure 14 – separate structures that, if equated to the “glide surface” of claim 1 as the EPO Examiner chose to do, clearly fall below the “planar upper portion (86)” of the slat in their entirety. What is more, as so defined, these separate structures do not

---

<sup>6</sup>Rapistan notes this distinction in its Reply Brief. See CRB 65.

surround the upper portion of the slat at all; indeed, they are not even “continuous.” Thus, the terse distinctions in Rapistan’s counterargument to the EPO have nothing to do with whether or where the “glide surface” contacts the slat. Accordingly, the notion that Rapistan’s counterargument to the EPO supports the interpretations of either Vanderlande or the Staff for the claim term “glide surface” in the U.S. ‘510 patent must be rejected.

In sum, the term “glide surface” in claims 1, 13, 17, 23, 30 and 42 of the ‘510 patent is construed to mean the inner portion of the diverter shoe’s support portion that consists of a surface that moves over or along the surface of the slat in a smooth, effortless manner without pivoting or rolling. Structurally, the “glide surface” is merely a two-dimensional surface and does not imply any points of contact or non-contact between the inner surface of the diverter shoe and the outer surface of the slat wall. In claim 1, the “glide surface” element has the additional characteristics of being “substantially continuous” and “having substantially the same configuration as [the] outer surface of [the] slat,” but points of contact or non-contact between the glide surface and the slat are not claimed features of that element. By contrast, in claims 13, 17 and 23, “glide surface”is associated with points of contact with the slat wall, in that either the “bearing means” element of claim 13 or the “means defining lateral stabilizing means” element of claims 17 and 23 provide for contact between the glide surface and the slat. Claims 13, 17, and 23, however, do not require the glide surface to be “continuous” or to be configured substantially the same as the outer surface of the slat, as in claim 1. Finally, in claims 30 and 42, the “glide

portion including means defining a glide surface adapted to glide along one of said slats” is a “means plus function” element under the provisions of 35 U.S.C. § 112, ¶ 6 that requires the function of “glid[ing] along one of said slats” to be performed by structure consisting of a substantially continuous surface that surrounds and has substantially the same configuration as the slat, with the slat having a roughly parallelogram-shaped cross-section, and contact points between the shoe and slat at diagonally opposite enlarged radius corners of the slat. Further, in accordance with 35 U.S.C. § 112, ¶ 6, an equivalent structure would also literally satisfy this element.

**7. “Surrounding said wall” (Claims 1, 13, 23)**

Rapistan contends that the claim term “surrounding said wall” in claims 1, 13 and 23 has an ordinary meaning, which should be interpreted as “to extend on all sides; to encircle; to enclose on all sides to cut off communication or retreat.” CIB 61-62. Vanderlande does not dispute Rapistan’s interpretation as far as it goes, but adds that the term requires “a low friction surface that contacts the top, bottom, and side of the slat walls,” including, in particular, “contact on the upper conveying surface of the slat,” in order to constitute a “glide surface surrounding said wall” under claims 1, 13 and 23. RIB 23 and 32. The Staff agrees with Rapistan’s definition and disagrees with Vanderlande’s additional requirement of contact on all sides of the slat, considering Vanderlande’s interpretation to be a departure from the ordinary meaning of the term. SIB 32; SRB 9.

As already discussed in connection with the interpretation of the claim term “glide surface,” contact between the glide surface and the slat is not a requirement

of claim 1. The claim term “surrounding said wall” does not change this fact. As the Staff points out, the claim term “surrounding” does not imply the necessity of contact with that which is being surrounded. SRB 9. [

]

[

]

[

] this contention does not import “positioning points of contact on all sides of the slat” into the asserted claims for the purpose of finding literal infringement in the present case. [

] As the Staff

points out, contact on all four sides may be sufficient to meet the “surrounding” limitation in the case of a shoe that does not entirely encircle the slat, but it does not make contact on all four sides necessary to do so. See SRB 12.

The contentions of Rapistan’s attorneys in the Hytrol case constitute only extrinsic evidence of the proper construction of this claim term. As such, they are “to

be used for the court's understanding of the patent, not for the purpose of varying or contradicting the terms of the claims." Markman, supra, 52 F.3d at 980-81. As the Federal Circuit has also pointed out:

[T]estimony on the *technology* is far different from other expert testimony, whether it be of an attorney, a technical expert, or the inventor, on the *proper construction* of a disputed claim term . . . . The latter kind of testimony may only be relied upon if the patent documents, taken as a whole, are insufficient to enable the court to construe disputed claim terms. Such instances will rarely, if ever, occur. . . . Even in those rare instances, prior art documents and dictionaries, although to a lesser extent, are more objective and reliable guides. Unlike expert testimony, these sources are accessible to the public in advance of litigation. They are to be preferred over opinion testimony, whether by an attorney or artisan in the field of technology to which the patent is directed. Indeed, opinion testimony on claim construction should be treated with the utmost caution, for it is no better than opinion testimony on the meaning of statutory terms.

Vitronics Corp. v. Conceptoronic, Inc., 90 F.3d 1576, 1585 (Fed.Cir. 1996) (emphasis in italics in original; underscored emphasis added). In the present case, where it is undisputed that the Vanderlande shoe surrounds the Vanderlande slat in its entirety without any gaps, unlike the Hytrol device, it stands to reason that the distinctions that Rapistan made in connection with the Hytrol device are simply irrelevant here.

Accordingly, the term "surrounding said wall" in claims 1, 13 and 23 is construed to mean "to extend on all sides; to encircle; to enclose on all sides to cut off communication or retreat." As with the term "glide surface" that precedes it in the claims, the term "surrounding said wall" does not imply any points of contact or non-contact between the inner surface of the diverter shoe and the outer surface of the slat wall.

## 8. “Joining edges” (Claims 13 and 23)

According to Rapistan, in the element in claims 13 and 23 wherein the upper and lower wall portions of the slats are “joined by side wall portions defining joining edges between each of said wall portions,” the words “edge” and “between” are to be accorded their ordinary meaning. CRB 43. Rapistan contends that there are several dictionary definitions of the word “edge,” including “the cutting side of a blade” and “the narrow part adjacent to a border <walk on the ~ of the deck>.” *Id.*, quoting from Webster’s New Collegiate Dictionary 358. These definitions, Rapistan contends, are consistent with an interpretation of “edge” to include the region surrounding an outside edge. *Id.* Thus, Rapistan maintains, regions of a wall portion can be part of a joining edge and of a wall portion at the same time. CRB 45-46. As for the word “between,” Rapistan also refers to a dictionary definition of “something in common to or shared by.” *Id.*, quoting from Webster’s New Collegiate Dictionary 105. Thus, according to Rapistan, a “joining edge” is the region around the corner formed between two adjacent wall portions of the slat. CRB 43-44. The joining edges of the ‘510 patent, Rapistan argues, comprise the ends of the wall portions themselves, and therefore are part of the wall portions but are simply located at a particular region of the wall portion. CRB 44.

Vanderlande argues that “joining edges” between each of said wall portions” refers to the edges formed where wall portions meet. RIB 56. An “edge,” according to Vanderlande’s preferred dictionary definition, is “where an object or area ends or begins.” *Id.*, quoting from Merriam Webster’s Collegiate Dictionary 366. Thus,



according to Vanderlande, the “joining edge” is the line through the slat (from the outer surface to the inner surface) where either the upper or lower wall portion ends and the side wall portion begins. RIB 57. Vanderlande also argues that since the “means defining lateral stabilizing means” of claim 17 is located “between one of said wall portions of each of said slats and an engaging portion of said glide surface of the corresponding one of said diverter shoes,” the claimed “lateral stabilizing means” can only be located at a “wall portion,” not at a “joining edge.” RIB 57. According to Vanderlande, it is impossible for the same structure to be both (i) between a joining edge and an engaging portion fo the glide surface and (ii) between a wall portion and an engaging portion of a glide surface. Id.

The Staff argues that the “joining edges” of the slat are defined by the intersections where the side wall portions are “joined” with the upper and lower wall portions of the slat. SIB 35. In the preferred embodiment of the ‘510 patent, according to the Staff, the various wall portions are joined at “enlarged radius corners.” Id., citing CX-1 (‘510 patent, col. 3:22-24). Additionally, the Staff points out, the “bearing means” limitation (discussed later herein) requires contact between the shoe and the slat at at least one “joining edge,” thus confirming in the Staff’s view that the “joining edges” of the slat are the outside corners of the slat. Id.

Claims 13 and 23 state that the upper and lower wall portions are each “joined by side wall portions defining joining edges between each of said wall portions.” CX-1 (‘510 patent, cols. 6:68-7:2 (claim 13) and 7:50-53 (claim 23)). The words “joining edges” are not used anywhere in the specification of the ‘510 patent. In terms of the

preferred embodiment, the '510 patent specification refers to the corresponding structure as "corners." See CX-1 ('510 patent, col. 3:22-24 and 4:63-66; Fig. 3 items 38 and 40; Fig. 8 items 64 and 66). Relevant dictionary definitions of the word "edge" include that of a "border," "the narrow part adjacent to a border," and "a line or line segment that is the intersection of two plane faces (as of a pyramid) or of two planes." See Webster's New Collegiate Dictionary 358 (1979) (first definition of "edge").<sup>7</sup>

In short, at a point where an upper or lower wall portion of a slat meets a side wall portion, a "joining edge" is formed between each of them. The "bearing means" that is "defined" "between" such a joining edge and "an engaging portion of said glide surface" is not a mathematically precise point, however. See Radcliffe Tr. 1212:25-1213:8. It is, rather, a small region of the glide surface and a corresponding small region around the point at which a "joining edge" is located on the slat, and it is in this region that the "transfer of forces between the slat and the shoe" occurs. See

---

<sup>7</sup>Both Rapistan and Vanderlande refer in their post-hearing briefs to exhibits "CX-661A" and RX-641 that purportedly contain dictionary definitions of the word "edge." See CRB 43 and RIB 56. "CX-661A" has never been offered or admitted as an exhibit, and RX-641 does not include the purported definition. Aside from the inappropriate reference by both parties to nonexistent exhibits, the Administrative Law Judge is entitled to take judicial notice of dictionary definitions at any time as an aid to determining the ordinary meaning of claim terms, and does so here. See Bell Atlantic, supra, 262 F.3d at 1267-68 ("Dictionaries and technical treatises, which are extrinsic evidence, hold a 'special place' and may sometimes be considered along with the intrinsic evidence when determining the ordinary meaning of claim terms."); Vitronics, supra, 90 F.3d at 1584 n.6 (Judges are free to consult dictionaries "at any time in order to better understand the underlying technology and may also rely on dictionary definitions when construing claim terms, so long as the dictionary definition does not contradict any definition found in or ascertained by a reading of the patent documents.").

Radcliffe Tr. 878:20-879:13. This is also evident from Vanderlande's own view of "bearing means" as disclosed in the preferred embodiment of the '510 patent, which consists of such small regions of contact between the slat and shoe at the joining edges. See Radcliffe Tr. 1207:17-1208:3; RDX-23.

For this reason, Vanderlande's contention that a "lateral stabilizing means" as defined in claim 17 can only be located at a "wall portion," not at a "joining edge," is without merit. While the preferred embodiment of the '510 patent does not disclose any structure that fits both the "bearing means" and "lateral stabilizing means" elements simultaneously, it is not inconceivable that a structure could do so, and the patent does not preclude such a possibility from being covered by the claims. See Sun Studs, Inc. v. ATA Equipment Leasing, Inc., 872 F.2d 978, 989 (Fed.Cir. 1989) ("An apparatus claim describing a combination of components does not require that the function of each be performed by a separate structure in the apparatus. The claimed and accused devices must be viewed and evaluated as a whole."); Magrath v. Draper Corp., 384 F.2d 672, 673 (1st Cir.1967) (infringement is not avoided by making into one part that which has been shown as two). Inasmuch as a "joining edge" includes a small region of the wall portions surrounding the point at which the two meet, that small region could not only function as a "bearing means" covered by claim 13, but could also be the site of a "means defining lateral stabilizing means between one of said wall portions of each of said slats and an engaging portion of said glide surface of the corresponding one of said diverter shoes" under claim 17. See CX-1 ('510 patent, col. 7:21-24) (emphasis added).

Accordingly, the element in claims 13 and 23 wherein the upper and lower wall portions of the slats are “joined by side wall portions defining joining edges between each of said wall portions” is construed to mean that at a point where either an upper or lower wall portion of a slat meets a side wall portion of the slat, a line at the intersection of the two walls is formed between them that includes a small region adjacent to that line on each wall surface. That small region can be part of the “joining edge” of claims 13 and 23, as well as part of the “wall portion” of claim 17 that makes up, in part, the “lateral stabilizing means” of that claim.

**9. “Bearing means” (Claim 13)**

According to Rapistan, the element in claim 13 consisting of a “bearing means defining a bearing between at least one of said joining edges of each of said slats and an engaging portion of said glide surface of the corresponding one of said diverter shoes” is not a “means plus function” element that invokes the provisions of 35 U.S.C. § 112, ¶ 6, even though the word “means” is used. CIB 43; CRB 40. Rather, Rapistan maintains, “bearing means” is a structural element that engages another moving structure during relative motion between the two structures and provides ease of relative movement between them. CIB 42-43.

Rapistan further argues that claim 13 requires the bearing to be at a joining edge of the slat, but not at a joining edge of the shoe. CIB 43. Regarding the shoe, Rapistan contends, the bearing must only be at an unspecified “engaging portion” of the glide surface on the corresponding shoe. CIB 43-44. Consequently, Rapistan maintains, the preferred embodiment discloses seven components that each constitute

a “bearing means,” shown in the following demonstrative exhibit as “bearing surfaces” A-F:

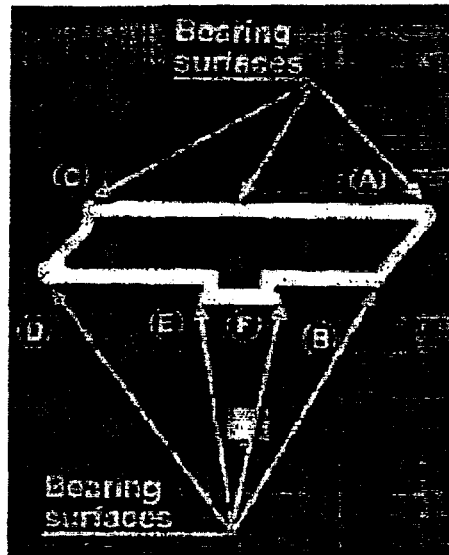

See CDX-34, slide 8a (part).

Vanderlande argues that the “bearing means” element is a “means plus function” element governed by 35 U.S.C. § 112, ¶ 6. RIB 55; RRB 36. The only structures in the specification of the ‘510 patent that fulfill this claim element, Vanderlande argues, are the “enlarged radius corners 38 and 40 at the upper forward and lower rear corners of the slat which come in contact with enlarged radius corners 64 and 66 of the inner wall of the support member of the diverter shoe. RIB 56; RRB 37-38.

The Staff agrees with Rapistan that “bearing means” is not a “means plus function” element governed by 35 U.S.C. § 112, ¶ 6, because the word “bearing” describes a structure rather than a function; namely, a “bearing” is a device across

which forces are transferred. SIB 36. The Staff further contends that this limitation requires that at least one of the contact surfaces of the shoe's glide surface engage the slat at an outside corner of the slat. SIB 37.

As discussed earlier in connection with the claim term "track means," if a claim element contains the word "means" and recites a function, it is presumed that the element is a means-plus-function element under 35 U.S.C. § 112, ¶ 6. Wenger, *supra*, 239 F.3d at 1232. That presumption falls, however, if the claim itself recites sufficient structure to perform the claimed function. Envirco, *supra*, 209 F.3d at 1364. "Conversely, the recitation of some structure in a means plus function element does not preclude the applicability of section 112(6)." York, *supra*, 99 F.3d at 1574.

Rapistan and the Staff argue that the word "bearing" in claim 13 connotes structure, and as such the addition of the word "means" does not invoke the provisions of 35 U.S.C. § 112, ¶ 6. Since the triggering "means" word is present in the claim element, the presumption applies and a determination must be made as to whether the claim recites "sufficient structure for performing the claimed function, thereby overcoming the presumption of § 112, ¶ 6." Envirco, *supra*, 209 F.3d at 1365. In the case of the "bearing means" element of claim 13, this must be done by determining whether the term "bearing" has a reasonably well understood meaning in the art as a name for structure. Watts, *supra*, 232 F.3d at 881.

The only word in the "bearing means" element that connotes a function of the claimed means is the word "defining." The function performed by the "bearing means" is nothing more than the defining of a structure that consists of a "bearing"

that exists between “at least one of said joining edges” of each slat and “an engaging portion” of the glide surface of the corresponding diverter shoe. See CX-1 (‘510 patent, col. 7:5-8). This “function” of “defining” a structure is indistinguishable from claim language that describes structure; but for the presence of the word “means,” the language of this element of claim 13 would delineate sufficient structure to qualify as a non-“means plus function” element. Therefore, unlike the “track means” element of other asserted claims of the ‘510 patent discussed earlier herein, the “bearing means” language of claim 13 does not evoke the provisions of 35 U.S.C. § 112, ¶ 6. See Wenger, supra, 239 F.3d at 1237 (rejecting applicability of 35 U.S.C. § 112, ¶ 6 to the element “means defining a plurality of separate product coating zones,” stating: “CMS asserts that the function of ‘defining’ is the function that corresponds to the word ‘means.’ Even assuming that is correct, we agree with Wenger that § 112, ¶ 6 does not apply because the claim recites sufficiently definite structure for performing the function of ‘defining.’”).

In addition, the experts for both Rapistan and Vanderlande agree that there is a wide variety of different kinds of bearings that are known in the art. See Radcliffe Tr. 874:23-875:20; Hoet Tr. 2031:24-2033:2; FF 142. The bearings used in the ‘510 patent, according to Rapistan’s expert, Radcliffe, are “surface-contact bearings.” Radcliffe Tr. 875:2-4; FF 143. According to Vanderlande’s expert, Hoet, they are “sliding surface bearings.” Hoet Tr. 2032:8-11, 15-25; FF 144. Both experts describe the function of such bearings in similar terms: Radcliffe, as “hav[ing] contacts between surfaces or portions of surfaces, and one surface presses against the

other to provide a force to engage across the bearing;” and Hoet, as “two surfaces that slide past each other.” Radcliffe Tr. 875 4-6; Hoet Tr. 2032:19-21; FF 145. Thus, both experts agree that the “bearing means” called for by claim 13 is a recognizable structure that has a reasonably well-understood meaning in the art. See Watts, supra.

Vanderlande refers to Louis Berkman Co. v. Davit Master Corp., 46 U.S.P.Q.2d 1380, 1998 WL 181603 (M.D. Fla. 1998) (“Berkman”) in which it was determined that the claim term “bearing means” in the patent at issue fell under the provisions of 35 U.S.C. § 112, ¶ 6. RIB 55-56; RRB 36. However, as the Staff points out, the claim element at issue in Berkman recites a “bearing means for slidably engaging said track means so as to slide along thereon.” SRB 13, citing Berkman, 1998 WL 181603 at \*1 (emphasis added). “Slidably engaging the track so as to slide thereon” connotes an active function rather than structure, as the court in Berkman found; that function is quite unlike the merely passive “definition” of structure that occurs in the “bearing means” element at issue here. Further, unlike this case, there is no evidence in Berkman of whether “bearing means” in that context was found to be a reasonably well-understood term in the art for the claimed structure. See Watts, supra.

Although Rapistan and the Staff are thus correct that the “bearing means” element of claim 13 recites sufficient structure to successfully rebut the presumption that 35 U.S.C. § 112, ¶ 6 applies in this instance, the structure so identified does not extend to all seven of the so-called “bearing surfaces” identified by Rapistan. As Vanderlande correctly points out, the only structure in the preferred embodiment that



is specifically covered by the claimed “bearing means” is set forth in the written description of the patent as follows:

The bearing means is provided by an enlarged radius surface at the slat edge. Such bearing means are preferably provided at diagonally opposite slat edges in order to better resist reaction forces about the axis of the slat.

\* \* \*

Continuous surface 50 additionally includes an enlarged radius forward upper corner 64 and an enlarged radius lower rear corner 66, in which enlarged radius corners 38 and 40 of the slat, respectively, ride. This arrangement provides bearing engagement between the enlarged radius corners of the slat and the corresponding corners of surface 50 to resist reaction forces tending to rotate the shoes about the axis of elongation of the slat.

\* \* \*

The bearings defined between enlarged radius corners 38 and 40 of the slats and corners 64 and 66 of the support members resist reaction forces about the long axis C of the slats (see FIG. 9). However, the bearings defined between the enlarged radius corners of the slat and support member allow easy gliding of the diverting shoe along the slat.

CX-1 (‘510 patent, cols. 1:66-2:2, 3:43-51; 4:63-5:1) (emphasis in bold in original; underscored emphasis added).

Thus, the only “bearing means” identified in the preferred embodiment of the ‘510 patent are the “enlarged radius corners 38 and 40 of the slats” that are located between “at least one of said joining edges of each of said slats,” and these corners contact “enlarged radius forward upper corner 64” and “enlarged radius lower rear corner 66” constituting the “engaging portion[s] of said glide surface” as claim 13 requires. These structures correspond exactly to components “A” and “D” of the

seven “bearing surfaces” shown in Rapistan’s demonstrative exhibit CDX-34 slide 8a (part) discussed previously. Also, since claim 13 requires that the bearing means must be “between one of said joining edges of each of said slats and an engaging portion of said glide surface,” and since “joining edge” is defined in the claim as “a wall having generally planar upper and lower wall portions joined by side wall portions defining joining edges between each of said wall portions,” components “B” and “C” of Rapistan’s demonstrative exhibit fulfill this claim term as well. However, as will be seen below, components “E” and “F” do not fulfill this claim term.

Claim 17, depending from claim 13, covers more patentable subject matter than claim 13. Besides the “bearing means” of claim 13, claim 17 adds more structure to the claimed conveying system by “further including means defining lateral stabilizing means between one of said wall portions of each of said slats and an engaging portion of said glide surface of the corresponding one of said diverter shoes . . . .” See CX-1 (‘510 patent, col. 7:20-24) (emphasis added). As Vanderlande points out, claim 17’s additional “means plus function” limitation is directed to a different function than the “bearing means” limitation of claim 13. See RRB 39. This “lateral stabilizing means” is not described in either the claim or the specification of the ‘510 patent as part of the “bearing means” structure, but rather as something different:

A lateral stabilizing means is additionally provided between each slat and an engaging portion of the glide surface of the corresponding diverter shoe in order to resist vertical axis reaction forces.

\* \* \*

When the diverting shoes are assembled in this manner and mounted to the slats 22, the T-shaped projections 42 on the slats engage channel 58 of the support member 44 in order to provide a lateral stabilizer to resist vertical-axis reaction forces applied about axis B to the diverting shoe 28 (see FIG. 8).

CX-1 ('510 patent, cols. 2:3-6, 4:52-57) (emphasis in bold in original; underscored emphasis added).

The word “further” in claim 17 makes clear that the “means defining lateral stabilizing means” is an additional feature in claim 17 that does not appear in claim 13. See 2 P. Rosenberg, Patent Law Fundamentals § 14.08, at 14-52 (1999 Rev.) (“Where the dependent claim adds an element of structure (whether a means or a step), its transitional phrase is usually preceded by the word ‘further’ (e.g., ‘The apparatus according to claim 1 further comprising . . . ’).”) (emphasis in original). Thus, claim 17 covers components “E” and “F” of Rapistan’s demonstrative exhibit CDX-34, slide 8a (part), but does not cover components “A” through “D.” It is conceivable, however, that a single component of an accused device could combine both the “bearing means” requirement of claim 13 and “lateral stabilizing means” requirement of claim 17. Although none of the aforementioned components of the preferred embodiment of the ‘510 patent do so, nothing in claims 13 and 17 prevent both claim elements from covering such a structure.

Rapistan contends that limiting the bearing means of claim 13 to the “enlarged radius corners” of the preferred embodiment would violate the doctrine of claim differentiation because it would then cover the same subject matter as claim 14, rendering that claim superfluous. CIB 45-46. Claim 14, which depends from

claim 13, covers “[t]he conveying system in claim 13 wherein said bearing means includes means defining an enlarged radius surface at said one of said joining edges.” See CX-1 (‘510 patent, col. 7:9-11). Vanderlande disagrees, arguing that claim 14 further defines the structure for performing the function of the bearing means of claim 13 (which, according to Vanderlande, is a “means plus function” element). RRB 38-39.

Merely pointing out particular structures in the preferred embodiment that satisfy the “bearing means” limitation of claim 13 does not limit the scope of that claim as Rapistan contends, irrespective of whether claims 13 and 14 are “means plus function” claims under 35 U.S.C. § 112, ¶ 6 or not. “[C]laims are construed in light of the specification, and are not limited to a designated ‘preferred embodiment’ unless that embodiment is in fact the entire invention presented by the patentee. [citation omitted]. When the claims include means-plus-function terms in accordance with § 112 ¶ 6, claim scope necessarily is not limited to the preferred embodiments, but includes equivalents thereof.” Vulcan Engineering Co., Inc. v. Fata Aluminium, Inc., 278 F.3d 1366, 1376 (Fed.Cir. 2002). Thus, since claim 13 is not a “means plus function” element as decided above, it therefore covers any accused structure on which it literally reads. This includes components “A” through “D” of Rapistan’s demonstrative exhibit RDX-34 slide 8a (part). By contrast, claim 14, as a dependent “means plus function” element, is more narrowly limited to bearing means that include the “enlarged radius surface at said one of said joining edges” that is depicted in items 38 and 40 on the slat and items 64 and 66 on the glide

surface of the diverter shoe, or their structural equivalents. This too could cover components “A” through “D” of Rapistan’s demonstrative, but could only cover other structures that are also functionally identical and structurally equivalent, as required by 35 U.S.C. § 112, ¶ 6.

Accordingly, the term “bearing means defining a bearing between at least one of said joining edges of each of said slats and an engaging portion of said glide surface of the corresponding one of said diverter shoes” is not to be construed according to 35 U.S.C. § 112, ¶ 6 as a “means plus function” element, and is construed to mean a structural element that engages another moving structure during relative motion between the two structures and provides ease of relative movement between them, and that is located between at least one of the joining edges of each slat and an engaging portion of the glide surface of the corresponding diverter shoe. Although this “bearing means” is different from the “lateral stabilizing means” of claims 17 and 23, a single component in an accused device could conceivably satisfy both claim elements.

**10. “Means defining lateral stabilizing means” (Claims 17 and 23)**

According to Rapistan, the element of dependent claim 17 (depending from claim 13) and independent claim 23 consisting of a “means defining lateral stabilizing means between one of said wall portions of each of said slats and an engaging portion of said glide surface of the corresponding one of said diverter shoes, said lateral stabilizing means resisting vertical-axis reaction-force-couples,” is a structural element, not a “means plus function” element that invokes the provisions

of 35 U.S.C. § 112, ¶ 6. CIB 73; CRB 47. The corresponding structure disclosed in the '510 patent, according to Rapistan, is a laterally extending, mating channel and extension arrangement cooperative between the shoe and the slat, with an operative length several times greater than its width. CIB 73. The purpose of the “lateral stabilizing means,” according to Rapistan, is described in the specification of the '510 patent as being “to resist vertical axis reaction forces.” *Id.*, quoting from CX-1 ('510 patent, col. 2:3-6). The preferred embodiment establishes, according to Rapistan, that the cooperative projection and channel “prevent wedging of the shoe by providing an approximate 5:1 length-to-width ratio.” CIB 74, quoting from CX-1 ('510 patent, col. 4:58-61). This element operates to provide two mating sets of spaced vertical walls that are relatively long as compared to the width spacing of those vertical walls. CIB 74.

According to Rapistan, the preferred embodiment is described in the '510 patent specification as “preferably a T-shaped outward extension of one portion of the slat engaging a mating portion of the shoe glide surface.” CIB 74-75, quoting from CX-1 ('510 patent, col. 2:7-9) (emphasis in brief). Thus, Rapistan maintains, the T-shape of the protrusion is not necessary to the element's structure. *Id.* The patent specification also provides that in this structure, “[a] definite clearance is provided between the bottom of projection and the bottom of channel 58 for debris tolerance.” See CX-1 ('510 patent, col. 4:61-63). However, Rapistan argues, a “definite clearance” for debris is not necessary to the claimed function of the “lateral stabilizing means.” CRB 50.

According to Vanderlande, the “means defining lateral stabilizing means” element of claims 17 and 23 is a “means plus function” element that invokes the provisions of 35 U.S.C. § 112, ¶ 6, not a structural element. RIB 58; RRB 40-41. The use of the word “means” creates a presumption that the limitation is a “means plus function” element, Vanderlande maintains, and Rapistan points to no structure in the claim to rebut the presumption. RRB 41. The phrase “lateral stabilizing,” Vanderlande argues, does not recite any structure let alone sufficient structure to take the claim out of Section 112, paragraph 6. RIB 58. Moreover, Vanderlande maintains, the T-shaped structure of the patented invention, as opposed to a rectangular projection, was recognized by the inventors as important to the invention for proper contact with the channel and they did not recognize that a rectangular projection could be used until years later. *Id.* The patent does not contain a description of any other structure for performing the claimed function, Vanderlande argues. RRB 43. Further, Vanderlande argues, if the T-shaped member were changed there would not be sufficient contact. RRB 45. The structure corresponding to the claimed “means,” according to Vanderlande, also requires a definite clearance between the bottom of the slat and the bottom of the channel for debris tolerance. *Id.*, quoting from CX-1 ((‘510 patent, col. 4:61-63). Without that clearance, Vanderlande argues, the diverter shoe would jam. RRB 44-45.

The Staff maintains that the “means defining lateral stabilizing means” element is a “means plus function” element that invokes the provisions of 35 U.S.C. § 112, ¶ 6, because the word “means” in the claim presumptively invokes that

provision and because the term is linked to the function of lateral stabilization, which is more specifically described in the claim as providing resistance to vertical-axis reaction-force-couples. SIB 37. Further, the Staff contends, the claim language is insufficient to inform a person of ordinary skill in the art of the precise structure necessary to perform the recited function of lateral stabilization without resort to the specification. SIB 38. In the Staff's view, Rapistan fails to suggest an adequate structural definition for the limitation, only an essentially functional one. SRB 14. Therefore, in the Staff's view, 35 U.S.C. § 112, ¶ 6 applies. SIB 38.

The Staff further argues that the lateral stabilizer is a mechanism for stabilizing the shoe with respect to rotation about the vertical axis, and allows the shoe to move across the slat without jamming or wedging. SIB 38. The only specified structure for performing the claimed function, according to the Staff, is a T-shaped projection extending from the bottom of the slat into a channel on the inside bottom surface of the shoe. SIB 39; SRB 15. The Staff argues that this structure, or its equivalent, must be present in an accused product in order for claim 17 to be literally infringed. *Id.*

As noted earlier herein in connection with other claim terms, a claim element that contains the word "means" and recites a function is presumed to be a means-plus-function element under 35 U.S.C. § 112, ¶ 6. *Wenger, supra*, 239 F.3d at 1232. That presumption falls if the claim itself recites sufficient structure to perform the claimed function. *Envirco, supra*, 209 F.3d at 1364.



Here, claims 17 and 23 use the words “means defining lateral stabilizing means.” See CX-1 (‘510 patent, col. 7:21 and 56). “Lateral stabilizing” connotes a function; it does not suggest a specific structure in and of itself. The claims go on to state that the function of lateral stabilizing is performed “between one of said wall portions of each of said slats and an engaging portion of said glide surface of the corresponding one of said diverter shoes.” See CX-1 (‘510 patent, col. 7:21-24 and 56-59). That statement of where the function is done is structural in nature, but does not remove the rest of this functional element from Section 112, paragraph 6. See Laitram Corp. v. Rexnord, Inc., 939 F.2d 1533, 1536 (Fed.Cir.1991) (“The recitation of some structure in a means-plus-function element does not preclude the applicability of [§ 112, ¶ 6 when it] merely serves to further specify the function of the means. The recited structure tells only what the means-for-joining does, not what it is structurally.”) (emphasis in original). Finally, the claims state that the purpose of the lateral stabilizing means is that of “resisting vertical-axis reaction-force-couples.” See CX-1 (‘510 patent, col. 7:24-25 and 59-61). This phrase, too, recites only the purpose of the claimed function; it adds nothing structural to the claim.

Rapistan points to no structural aspect of claims 17 and 23 to rebut the presumption, supported by the foregoing analysis, that the “means defining lateral stabilizing means” element of claims 17 and 23 are anything but functional in nature. Accordingly, this element is determined to be a “means plus function” element that invokes the provisions of 35 U.S.C. § 112, ¶ 6.

As a “means plus function” element, an accused device that possesses the required “means defining lateral stabilizing means” must perform the specifically-claimed function of “lateral stabilizing” at the claimed location “between one of said wall portions for each of said slats and an engaging portion of said glide surface of the corresponding one of said diverter shoes” for the claimed purpose of “resisting vertical-axis reaction-force couples,” and must do so using structure that corresponds to the “structure, material, or acts described in the specification” of the ‘510 patent “and equivalents thereof.” See 35 U.S.C. § 112, ¶ 6. The “corresponding structure” is described in the “Summary of the Invention” section of the ‘510 patent specification as follows:

A lateral stabilizing means is additionally provided between each slat and an engaging portion of the glide surface of the corresponding diverter shoe in order to resist vertical axis reaction forces. The lateral stabilizing means is preferably a T-shaped outward extension of one portion of the slat engaging a mating portion of the shoe glide surface.

CX-1 (‘510 patent, col. 2:3-9). It is further described in the Description of the Preferred Embodiment section of the ‘510 patent specification as follows:

... the T-shaped projections 42 on the slats engage channel 58 of the support member 44 in order to provide a lateral stabilizer to resist vertical-axis reaction forces applied about axis B to the diverting shoe 28 (see FIG. 8). The structure of the T-shaped projection 42 is to prevent wedging of the shoe by providing an approximate 5:1 length-to-width ratio for the interface with channel 58. A definite clearance is provided between the bottom of projection and the bottom of channel 58 for debris tolerance.

CX-1 (‘510 patent, col. 4:54-63). The “T-shaped projection 42” is depicted in Figure 3 of the ‘510 patent as follows:



**Fig. 3.**

Part of '510 Patent Fig. 3

See CX-1 ('510 patent, Fig. 3 (part)). The corresponding "channel 58" is depicted in Figure 8 of the '510 patent as follows:

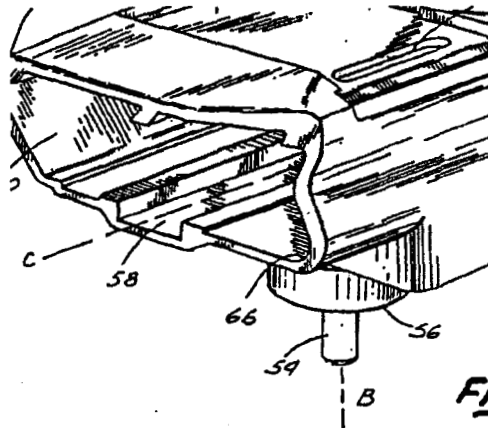

'510 Patent Fig. 8 (Part)

See CX-1 ('510 patent, Fig. 8 (part)).

The experts for both Rapistan and Vandcrlande agreed, as the foregoing description and drawings show, that the vertical walls of T-shaped projection 42 contact the vertical walls of channel 58 along the lateral axis of the shoe, for a sufficient length of the shoe in relation to its width (preferably a ratio of at least 5:1), to perform the claimed functional purpose of "resisting vertical-axis reaction-force-

---

couples” around axis B (as shown in Figure 8). See Radcliffe Tr. 935:8-936:14; Hoet Tr. 2038:17-2039:3; **FF 146**.

The written description also describes this structure as having “[a] definite clearance . . . between the bottom of projection and the bottom of channel 58 for debris tolerance.” CX-1 (‘510 patent, col. 4:61-63. “Debris tolerance” prevents debris from collecting between the lateral stabilizer projection of the slat and the channel of the shoe so that the shoe does not jam. See Cotter Tr. 625:14-626:19; **FF 147**. However, “debris tolerance” to prevent the shoe from jamming is not one of the recited functions of claims 17 and 23 and has not been demonstrated to have anything to do with the claimed purpose of “resisting vertical-axis reaction-force-couples.” By the same token, the particular shape of the disclosed structure as a “T” has not been shown to affect the claimed function, since it is only the correspondence of the vertical walls of the “T” shape with the vertical walls of the channel, and the lateral length of the shoe channel in relation to the shoe’s width, that affect the claimed function. Radcliffe Tr. 1247:24-1248:19; **FF 148**. “The corresponding structure to a function set forth in a means-plus-function limitation must actually perform the recited function, not merely enable the pertinent structure to operate as intended . . . .” Asyst Technologies, Inc. v. Empak, Inc. 268 F.3d 1364, 1371 (Fed.Cir. 2001).

Accordingly, the term “means defining lateral stabilizing means between one of said wall portions of each of said slats and an engaging portion of said glide surface of the corresponding one of said diverter shoes, said lateral stabilizing means resisting vertical-axis reaction-force-couples” as used in claims 17 and 23 is

construed according to 35 U.S.C. § 112, ¶ 6 as a “means plus function” element to mean a structure that performs the precise function of lateral stabilization, at a location between one of the wall portions of each slat and an engaging portion of the glide surface of the corresponding diverter shoe, for the purpose of resisting reaction-force-couples around the vertical axis of the shoe, by means of structure corresponding to the laterally-extending vertical walls of projection 42 of the slat that mate with the laterally-extending vertical walls of channel 58 of the shoe as shown in the preferred embodiment shown in the specification of the ‘510 patent, the channel of the shoe having a length-to-width ratio of at least 5:1, or equivalent structures thereof.

11. **“Contiguous, generally planar surfaces sloping downward from an upper extent of said diverting surface laterally inward and longitudinally forward or rearward” (Claim 30)**

Rapistan contends that the claim 30 term “a plurality of contiguous, generally planar surfaces sloping downward from an upper extent of said diverting surface laterally inward and longitudinally forward or rearward” includes two or more surfaces of the diverter surface of the diverter shoe that is operative to be contacted by an article, which surfaces are in contact with each other and are sloped downwardly from a horizontal plane that passes through the highest location on the shoe’s vertical diverting surface, at least one of which has a component that slopes laterally inward and at least one of which has a component that slopes either forwardly or rearwardly. CIB 78. According to Rapistan, these surfaces are disclosed in Figures 4, 5 and 6 of the ‘510 patent, showing in the preferred embodiment “a

series of contiguous deflecting surfaces 82a, 82b, 82c, 82d, 82e, 82f, 82g, 82h, 82i, 82j and 82k slop[ing] downwardly from diverting surfaces 78a, 78b toward the central axis A of diverting member 46a and forwardly and rearwardly with respect to the movement of the diverting member, which is in the direction of axis A.” Id.; CX-1 (‘510 patent, col. 4:3-9). Rapistan further contends that the purpose of these surfaces, as disclosed in the ‘510 patent, is so that “a package striking any of the surfaces 82a-82k will be deflective progressively upwardly to a point where the upper extent of the vertical diverting surfaces 78a, 78b may pass beneath the package.” CIB 79; CX-1 (‘510 patent, col. 4:9-13). In particular, Rapistan contends that surfaces 82c and 82j embody the “laterally inward” language of this claim element. CRB 55.

Vanderlande contends that this element requires two or more surfaces of the diverter surface to touch along a boundary, and that each of the surfaces must slant from the top of the diverting surface (the vertical wall at the end of the shoe to a lower place while heading towards the center line and either forward or inward. RIB 63 (emphasis in brief). Vanderlande further states that the topology of the walls is such that packages hitting any wall will travel upwards and outwards (the opposite of downward and inward) towards the side vertical walls so that the package will go over the side vertical wall. RIB 64. Vanderlande further contends that, to satisfy this claim element, every such surface must slope (1) downward, (2) laterally inward, and (3) either forward or rearwards. RRB 47-48. Vanderlande also contends that the ordinary meaning of the claim term applies in lieu of anything to the contrary in the specification of the ‘510 patent. RRB 48-49.

The Staff maintains that the plain language of this clause requires the upper portion of the diverter shoe to include (1) a substantially vertical diverting surface on at least one of its lateral ends and (2) at least two contiguous, generally flat surfaces sloping downward (from the upper extent of the diverting surface), laterally inward, and towards either the longitudinal front or rear of the shoe. SIB 46. Among the series of listed surfaces in the written description of the '510 patent that satisfy this claim element are at least two, identified as 82c and 82j, but in the Staff's view these surfaces slope downward and outward, not downward and inward. SIB 47. Thus, according to the Staff, these surfaces do not provide a sufficient basis to look to the specification for the meaning of "inwardly sloping," and the claim language should be given its "plain and ordinary meaning." SIB 48.

The specification describes three embodiments of diverting member -- a "bi-directional" member that can push packages laterally to both sides of the conveyor, and a "right-handed member" and "left-handed member," each of which can push packages to only one side or the other, respectively. See CX-1 ('510 patent, cols. 3:66-67 and 4:27-44); FF 149. The specification describes the bi-directional version (item 46a) of these components as follows:

A diverting member 46a is provided that is designed for use [on] a bi-lateral diverting sortation system. Diverting member 46a includes a right vertical diverting surface 78b. Diverting surfaces 78a and 78b are covered with a high friction polymeric band 80a, 80b. A series of contiguous deflecting surfaces 82a, 82b, 82c, 82d, 82e, 82f, 82g, 82h, 82i, 82j and 82k slope downwardly from diverting surfaces 78a, 78b toward the central axis A of diverting member 46a and forwardly and rearwardly with respect to the movement of the diverting member, which is in the direction of axis A. Therefore, a package striking any of the surfaces 82a-82k will be deflective progressively upwardly to

---

a point where the upper extent of the vertical diverting surfaces *78a*, *78b* may pass beneath the package.

CX-1 ('510 patent, cols. 3:66-4:13) (emphasis added); **FF 150**. The right-handed member (item *46b*), according to the specification, has a series of contiguous deflecting surfaces *82a - 82f* that correspond to the identically-numbered surfaces on one side of the bi-directional member, and the left-handed member (item *46c*) has a series of contiguous deflecting surfaces *82g - 82k* that correspond to the identically-numbered surfaces on the other side of the bi-directional member. See CX-1 ('510 patent, col. 4:27-43). Thus, the bi-directional member is simply a joining of the right-handed and left-handed versions.

The bi-directional, right-hand and left-hand diverting members of the invention of the '510 patent are depicted in Figures 4, 5 and 6, respectively, as follows:



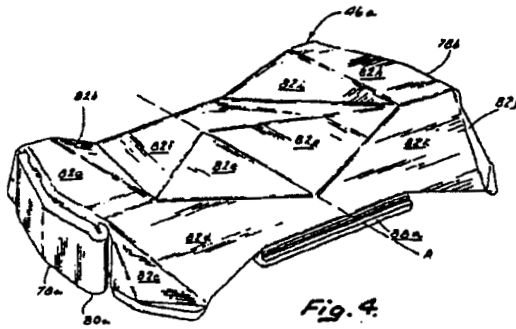

Fig. 4.

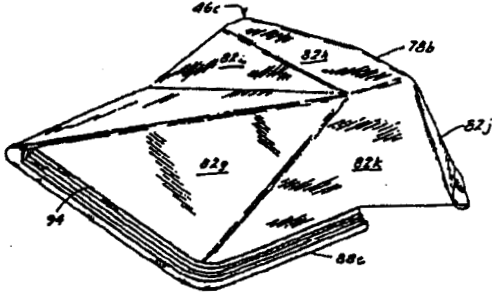

Fig. 6.

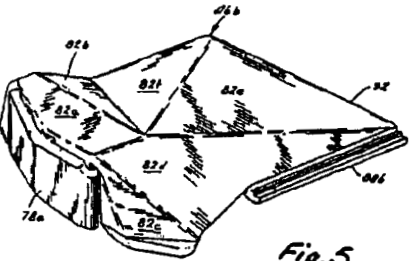

Fig. 5.

See CX-1 ('510 patent, Figs. 4-6); FF 151.

It is evident from the specification and drawings that the word "longitudinally" in the context of claim 30 means "in a direction parallel to the axis of flow of the conveyor system," and that the word "laterally" in that claim means "in a direction from one side of a slat to the other side along the axis of displacement of packages off the conveyor," i.e., perpendicular to the longitudinal direction. It is also evident from correlating the claim element to the corresponding portion of the written description that the claim term "inward" means the same thing as "toward the central axis A" of the bi-directional diverting member, as set forth in the written description and as shown in Figure 4. The right-hand member of Figure 5 and the left-hand

member of Figure 6 do not depict similar axis lines, but the written description of the '510 patent makes clear that "axis A" of the bi-directional member corresponds to the "laterally opposite side 92" of the right-hand member and to the "opposite lateral side 94" of left-hand member. See CX-1 ('510 patent, col. 4:27-43); **FF 152**. Accordingly, considering the specification and drawings, "inward" refers to a direction from the vertical diverting surface of the diverting member to either (i) the axis in between the vertical diverting surfaces, in the case of a bi-directional member; or (ii) the opposite side of the member from the diverting surface, in the case of a left-handed or right-handed member.

Vanderlande and the Staff both take issue with construing the claim term "inward" by resort to the specification of the '510 patent instead of using its ordinary meaning. SIB 47-48; RRB 48-49. However, both Vanderlande and the Staff have considerable difficulty in describing precisely what that ordinary meaning is, with Vanderlande attempting a construction in "topographical" terms and the Staff analogizing to a series of "trails" sloping up to a mountaintop. See RIB 63; SIB 48. "As a general rule, claim language carries the ordinary meaning of the words in their normal usage in the field of invention. [citation omitted]. Nevertheless, the inventor may act as his own lexicographer and use the specification to supply implicitly or explicitly new meanings for terms. [citation omitted]. Thus, a construing court may consult as well the written description, and, if in evidence, the prosecution history." Trintec Industries, Inc. v. Top-U.S.A. Corp., 295 F.3d 1292, 1294-95 (Fed.Cir. 2002). Here, in connection with the claim terms "downward," "laterally," "inward,"

“longitudinally,” “forward” and “rearward,” a mere reading of these directional words by themselves does not convey sufficient meaning without reading the specification and viewing the corresponding figures of the ‘510 patent because those intrinsic resources give particular definition to the spatial relationship of the diverting surfaces to one another in the disclosed structure. Accordingly, such intrinsic evidence must be taken into account in construing these terms.

Rapistan directs its arguments regarding the “plurality of contiguous, generally planar surfaces” claim element to surfaces 82c and 82j of the preferred embodiments. See CIB 79; CRB 55. In all three versions of the preferred embodiment, both of these surfaces slope in all three of the required directions of claim 30; namely, (i) downward from an upper extent of the vertical diverting surface; (ii) laterally inward toward the “central axis A” in the case of a bi-directional diverting member, or toward the “laterally opposite side” in the case of a right- or left-handed diverting member; and (iii) longitudinally forward toward the direction of movement of the conveyor system. Contrary to Vanderlande’s view, there is no need to consider whether all of the other surfaces of the disclosed embodiment satisfy these directions as well. See RIB 47-48. Claim 30 covers a diverter shoe “comprising,” inter alia, a diverting member having “a plurality of contiguous, generally planar surfaces . . .” See CX-1 (‘510 patent, col. 8:10, 17-18, and 22-25). “Plurality” means two or more, and in the context of this “open-ended” claim that uses the transition word “comprising,” if there are at least two such surfaces meeting all of the claim’s directional requirements, then there can also be other surfaces that

do not meet all of those requirements. See Certain Condensers, Parts Thereof and Products Containing Same, Including Air Conditioners For Automobiles, Inv. No. 337-TA-334 (Remand), Initial Determination at 35-36, 1996 WL 1056222 (U.S.I.T.C., December 10, 1996), adopted by Commission in relevant part, Commission Opinion, 1997 WL 599891 (U.S.I.T.C., September 10, 1997) (in an open-ended claim for an automobile condenser “comprising,” inter alia, “a plurality of tubes with flow paths of relatively small hydraulic diameter,” the fact that only some but not all of the tubes of the accused condenser had the required “relatively small hydraulic diameter” did not remove that accused device from the scope of the claim).

Accordingly, the claim 30 term “ a plurality of contiguous, generally planar surfaces sloping downward from an upper extent of said diverting surface laterally inward and longitudinally forward or rearward” is construed to mean at least two surfaces of the diverter surface of the diverter shoe that can contact an article, that are contiguous to other such generally planar surfaces, that slope downwardly from an upper extent of the diverting surface, that also slope laterally inward (i.e., either toward (i) the axis in between the vertical diverting surfaces, in the case of a bi-directional member; or (ii) the opposite side of the member from the diverting surface, in the case of a left-handed or right-handed member), and that also slope either forwardly toward or rearwardly from the direction of flow of the conveyor system.

## **V. Infringement**

### **A. Relevant Law**

#### **1. Literal Infringement**

Literal infringement is a question of fact. Tegal Corp. v. Tokyo Electron America, Inc., 257 F.3d 1331, 1350 (Fed.Cir. 2001). Literal infringement requires the patentee to prove that the accused device contains each limitation of the asserted claim(s). Each element of a claim is considered material and essential, and in order to show literal infringement, every element must be found to be present in the accused device. London v. Carson Pirie Scott & Co., 946 F.2d 1534, 1538 (Fed.Cir. 1991). If any claim limitation is absent from the accused device, there is no literal infringement of that claim as a matter of law. Bayer, *supra*, 212 F.3d at 1247.

#### **2. Infringement Under Doctrine of Equivalents**

Where literal infringement is not found, infringement nevertheless can be found under the doctrine of equivalents based on “the substantiality of the differences between the claimed and accused products or processes, assessed according to an objective standard” judged from “the vantage point of one of ordinary skill in the relevant art.” Hilton Davis Chemical Co. v. Warner-Jenkinson Co., 62 F.3d 1512, 1518-1519 (Fed.Cir. 1995) (“Hilton Davis”), *aff’d sub nom.* Warner-Jenkinson Co. v. Hilton Davis Chemical Co., 520 U.S. 17 (1997) (“Warner-Jenkinson”). Determining infringement under the doctrine of equivalents “requires an intensely factual inquiry.” Vehicular Technologies Corp. v. Titan Wheel International, Inc., 212 F.3d 1377, 1381 (Fed.Cir. 2000) (“Vehicular Technologies”). “In applying the

---

doctrine of equivalents, it is often enough to assess whether the claimed and accused products or processes include substantially the same function, way, and result.” Hilton Davis, 62 F.3d at 1518.

### 3. Prosecution History Estoppel

Although infringement can be demonstrated under the doctrine of equivalents in the absence of literal infringement, the doctrine of prosecution history estoppel “can prevent a patentee from relying on the doctrine of equivalents when the patentee relinquishes subject matter during the prosecution of the patent, either by amendment or argument.” Pharmacia & Upjohn Co. v. Mylan Pharm., Inc., 170 F.3d 1373, 1376-77 (Fed.Cir. 1999). Prosecution history estoppel is a legal question for the court. Bayer, *supra*, 212 F.3d at 1251-54; Insituform Technologies v. Cat Contracting, 99 F.3d 1098, 1107 (Fed.Cir.1996), *cert. denied*, 520 U.S. 1198 (1997).

According to the rule of “amendment-based estoppel,” “when an applicant narrows a claim element in the face of an examiner’s rejection based on the prior art, the doctrine estops the applicant from later asserting that the claim covers, through the doctrine of equivalents, features that the applicant amended his claim to avoid. A patentee is also estopped to assert equivalence to ‘trivial’ variations of such prior art features.” Litton Systems, Inc. v. Honeywell, Inc., 140 F.3d 1449, 1462 (Fed.Cir. 1998). Under the rule of “argument-based estoppel,” “[c]lear assertions made during prosecution in support of patentability, whether or not actually required to secure allowance of the claim, may also create an estoppel.” Southwall Technologies v. Cardinal IG Co., 54 F.3d 1570, 1583 (Fed.Cir.), *cert. denied*, 516 U.S. 987 (1995);

also see Canton Bio-Medical, Inc. v. Integrated Liner Technologies, Inc., 216 F.3d 1367, 1371 (Fed.Cir. 2000). In determining whether estoppel exists, “[t]he legal standard for determining what subject matter was relinquished is an objective one, measured from the vantage point of what a competitor was reasonably entitled to conclude, from the prosecution history, that the applicant gave up to procure issuance of the patent.” Hoganas AB v. Dresser Industries, Inc., 9 F.3d 948, 952 (Fed.Cir. 1993).

In Warner-Jenkinson, *supra*, the Supreme Court ruled that the reason for an amendment is relevant to prosecution history estoppel, particularly when it is “tied to amendments made to avoid the prior art, or otherwise to address a specific concern -- such as obviousness -- that arguably would have rendered the claimed subject matter unpatentable.” Warner-Jenkinson, 520 U.S. at 30-31. The Supreme Court further held that where the reason for an amendment is unclear, there is a presumption that prosecution history estoppel applies but is rebuttable “if an appropriate reason for a required amendment is established.” *Id.*, 520 U.S. at 33.

In Festo Corporation v. Shoketsu Kinzoku Kogyo Kabushiki Co., Ltd., \_\_\_U.S.\_\_\_, 122 S.Ct. 1831 (2002) (“Festo”), the Supreme Court elaborated on its prosecution history estoppel ruling in Warner-Jenkinson. Concerning the kinds of amendments that may give rise to estoppel, the Supreme Court decided that “a narrowing amendment made to satisfy any requirement of the Patent Act may give rise to an estoppel.” Festo, 122 S.Ct. at 1839. Thus, estoppel may arise not only from narrowing amendments to avoid prior art, but also from narrowing amendments to

satisfy the statutory requirements of usefulness, novelty and non-obviousness (35 U.S.C. §§ 101-103) as well as the statutory requirements of adequate descriptiveness in the specification and claims, enablement, and setting forth the best mode of carrying out the invention (35 U.S.C. § 112). See id. at 1839-40. While some Section 112 amendments may, according to the Supreme Court, be “truly cosmetic” and therefore would not narrow the patent’s scope or raise an estoppel, nevertheless “if a § 112 amendment is necessary and narrows the patent’s scope – even if only for the purpose of better description – estoppel may apply.” Id. at 1840.

The Supreme Court in Festo also addressed whether prosecution history estoppel bars the inventor from asserting infringement against any equivalent to the narrowed element, or whether some equivalents might still infringe. See Festo, supra, 122 S.Ct. at 1840. In reversing the Federal Circuit’s ruling below that a complete bar applies, the Supreme Court instead ruled in favor of a “flexible bar” that “requires an examination of the subject matter surrendered by the narrowing amendment.” Id. Recognizing the inherent limitation of words to describe an invention, the Supreme Court held:

The narrowing amendment may demonstrate what the claim is not; but it may still fail to capture precisely what the claim is. There is no reason why a narrowing amendment should be deemed to relinquish equivalents unforeseeable at the time of the amendment and beyond a fair interpretation of what was surrendered. Nor is there any call to foreclose claims of equivalence for aspects of the invention that have only a peripheral relation to the reason the amendment was submitted. The amendment does not show that the inventor suddenly had more foresight in the drafting of claims than an inventor whose application was granted without amendments having been submitted. It shows only that he was familiar with the broader text and with the difference between the two. As a result, there is no more reason for holding the



patentee to the literal terms of an amended claim than there is for abolishing the doctrine of equivalents altogether and holding every patentee to the literal terms of the patent.

Festo, supra, 122 S.Ct. at 1841.

The Supreme Court in Festo went on to hold that there is a rebuttable presumption that a narrowing amendment creates an estoppel, and that the patentee bears the burden of rebutting the presumption by proving that the amendment does not surrender the particular equivalent in question. See Festo, supra, 122 S.Ct. at 1842. “The equivalent may have been unforeseeable at the time of the application; the rationale underlying the amendment may bear no more than a tangential relation to the equivalent in question; or there may be some other reason suggesting that the patentee could not reasonably be expected to have described the insubstantial substitute in question.” Id. To rebut the presumption, “[t]he patentee must show that at the time of the amendment one skilled in the art could not reasonably be expected to have drafted a claim that would have literally encompassed the alleged equivalent.” Id.

**B. Direct Infringement**

**1. Do Respondents’ Mark 2 Posisorter Systems infringe claim 1 of the ‘510 patent?**

**a. Undisputed Claim Elements**

The parties do not dispute that the Mark 2 Posisorter system is, as required by claim 1, “a conveying system having a longitudinally moving conveying surface defined by the uppermost ones of a plurality of slats connected at opposite ends in spaced relation with each other to a pair of endless chains.” FF 153. They do not

dispute that the Mark 2 has “a plurality of diverter shoes each moveably mounted on one of said slats for lateral movement with respect to said conveying surface.” FF 154.

**b. “Track means”**

Rapistan and the Staff contend that the Mark 2 Posisorter system has the claim 1 requirement of a “track means engaging said diverter shoes for imparting a lateral force to move said diverter shoes laterally to displace product positioned on said conveying surface.” CIB 83-86; CRB 69-72; SIB 52; SRB 18-19. They point to the fact that the Mark 2 Posisorter utilizes a diagonally oriented rail or track that is engaged by a coaxial bearing on the underside of the diverter shoe. CIB 84; SIB 52. Rapistan additionally contends that the specification of the ‘510 patent references a diverter switch that is not restricted to any particular construction, orientation of movement, or manner of control such as by electric solenoid or pneumatic control. RIB 85. Of two different forms of diverter switches that are referenced in the specification of the ‘510 patent, Rapistan maintains, the diverter switch disclosed by the referenced Brouwer ‘347 patent is moved by pneumatic controls and pivoted horizontally. RIB 85. Rapistan points out that Vanderlande’s expert, Hoet, testified that the Mark 2 Posisorter system’s diverter switch is essentially the same as the diverter switch of the Brouwer patent. RIB 85. The Staff contends that a specific type of diverter switch is not required by the “track means” limitation, but if it is found to be so, then the prior art type of switch used by the Mark 2 is “corresponding structure” to the “track means” function. SIB 52; SRB 18-19.

Vanderlande contends that the Mark 2 Posisorter does not meet this “track means” limitation. RIB 78-79; RRB 54-55. According to Vanderlande, the Mark 2 Posisorter diverter switch rotates horizontally and is activated pneumatically, and therefore does not work the same way as the vertically-directed, electrically-powered solenoid of the diverter switch that is referenced in the specification of the ‘510 patent as being disclosed by the ‘912 patent. RIB 78-79. Accordingly, Vanderlande maintains, the diverter switch of the Mark 2 Posisorter does not satisfy the “track means” element literally or under the doctrine of equivalents. RRB 54-55.

The Mark 2 Posisorter system utilizes a diagonally oriented rail or track that is engaged by a coaxial bearing on the underside of the diverter shoe. Radcliffe Tr. 793:5-795:5, 1243:21-1245:14; Hoet Tr. 1954:10-1956:1; CX-221C; CPX-12; CPX-28; **FF 155**. The track imparts a lateral force to move the diverter shoes laterally in a manner that displaces product positioned on the conveying surface. Hoet Tr. 1954:10-1956:1; **FF 156**. Consistent with the diverter switch disclosed by the prior-art Brouwer ‘347 patent that is referenced by the specification of the ‘510 patent, the Mark 2 Posisorter system utilizes diverter switches that are moved by pneumatic controls and are pivoted horizontally. Hoet Tr. 1956:2-9; RX-333 (Brouwer ‘347 patent, cols. 3:41-58, 6:21-43); **FF 157**; **FF 69-71** (First Stipulation Nos. 70-72). As properly construed herein, the “track means” element is not restricted to electrically-controlled, vertically-oriented diverter switches, and encompasses the pneumatically-controlled, horizontally-oriented diverter switch of the prior-art Brouwer ‘347 patent. Accordingly, the Mark 2 Posisorter system literally satisfies the claim 1 element of

a “track means engaging said diverter shoes for imparting a lateral force to move said diverter shoes laterally to displace product positioned on said conveying surface.”<sup>8</sup>

**c. “Right cylinder”**

Rapistan and the Staff contend that in the Mark 2 Posisorter system, “each of said slats [are] defined by a wall formed as a right cylinder” as required by claim 1. CIB 88-91; CRB 70-72; SIB 52-53. Both Rapistan and the Staff recognize that the slat of the Mark 2 Posisorter has small deviations from a pure right cylinder, including two “drip edges” protruding from each end of the upper surface of the slat, two circular bolt-mounting holes designed for connecting the slat to the chain, a short side channel flange on the trailing side of the slat, and an internal wall. CIB 88 and 90; SIB 52. These deviations from a pure right cylinder, according to Rapistan and the Staff, are minor additions to the claimed “right cylinder” shape of the slat that, while more substantial than those shown in the preferred embodiment of the ‘510 patent (according to the Staff, SIB 53), nevertheless are small relative to the overall size and shape of the slat and do not detract from the structural strength given the slat by the closed right cylinder shape. CIB 91; SIB 53. Even if the Mark 2 slat is not literally found to comprise a right cylinder, Rapistan and the Staff maintain, it represents an insubstantial difference from the claim 1 requirement and would infringe under the doctrine of equivalents because the minor deviations from a right cylinder do not alter its functionality or detract from its structural nature of providing

---

<sup>8</sup>Throughout the infringement analysis of this Initial Determination, a finding of literal infringement also constitutes a finding of infringement under the doctrine of equivalents unless otherwise noted.

a closed shape that functions to provide strength and support to the planar conveying surface. CIB 91; SIB 53.

Vanderlande contends that the Mark 2 Posisorter does not meet this limitation. RIB 79-81; RRB 55-58. The Mark 2 slat, according to Vanderlande, does not have a fixed planar curved profile of a right cylinder, but instead is characterized by “sharp breaks, acute projections, and acutely angled corners.” RIB 79. To find infringement, Vanderlande argues, Rapistan’s expert, Radcliffe, simply ignored anything in the shape of the Mark 2 slat that would cause it not to be a right cylinder, including its drip edges, ridges, bolt holes, internal connecting wall, and rear support flange. RIB 80-81. These projections, according to Vanderlande, are vital to how the Mark 2 slat functions. RIB 81.

A cross-section of the slat of the Mark 2 Posisorter is depicted in CDX-14 as follows:

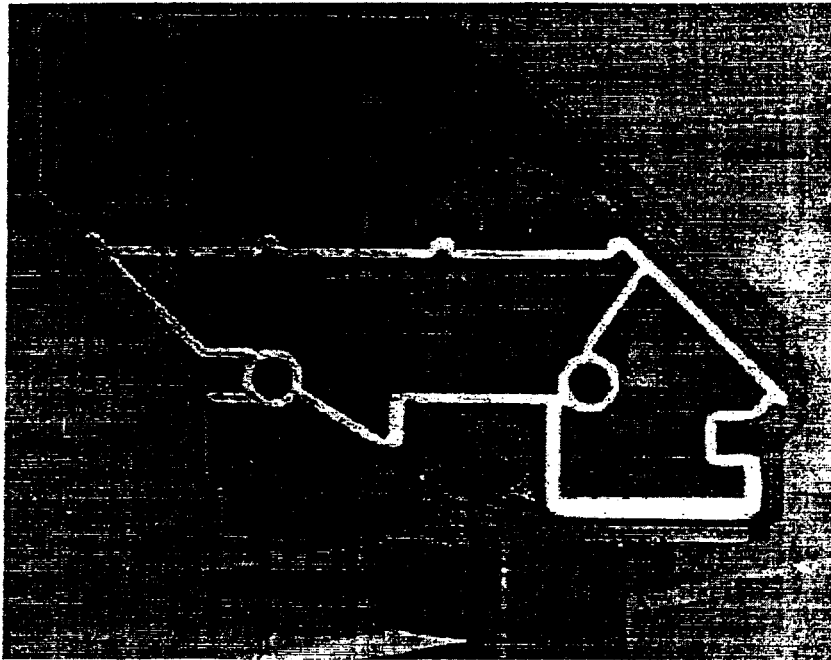

CDX-14; **FF 158**. The slat is defined by an outer wall, and that wall forms a “right cylinder” in that it forms a geometrically closed curve. See Radcliffe Tr. 811:13-14; **FF 159**. According to the specific language of claim 1, the “wall formed as a right cylinder” is what “defines” the slat of claim 1; in other words, it “establishes the boundaries of” the claimed slat. See Wenger, supra, 239 F.3d at 1237 (“define” means “establish the boundaries of”). Thus, the internal connecting wall on the right side of the profile provides inner support but does not contribute to the outer shape of the slat, and therefore is irrelevant to the claimed “wall formed as a right cylinder.” Radcliffe Tr. 1190:19-22; **FF 160**.

The two “drip edges” protruding from each end of the upper surface of the slat function to provide a sharp break so that liquids will not roll down the sides of the slats and damage the side channels. Van den Goor Tr. 1479:3-22; Radcliffe Tr. 1191:3-14; Hoet Tr. 2012:21-2014:13; **FF 161**. The ridges on the top conveying surface make a channel for liquids so that spilled liquids stay on the sorter until they are spilled off when the slat reaches the end of the sorter, and also so as to direct liquids to the lateral ends of the slats, away from the guide channels. Van den Goor Tr. 1480:3-1481:8; Hoet Tr. 2012:21-2014:13; **FF 162**. The ridges also provide increased friction to reduce or prevent packages from rotating when the sorter is sorting packages with soft bottoms, and also increase the stiffness of the slat. Van den Goor Tr. 1480:3-1481:8; **FF 163**. The two circular bolt-mounting holes are used to attach the diverter shoe to the chain that is used to move the slat and add stiffness to the slat. Van den Goor Tr. 1481:19-1482:6, 1482:11-12; **FF 164**. The short side

channel flange on the trailing side of the slat resists reaction forces and stabilizes the diverter shoe. Radcliffe Tr. 814:18-25; van den Goor Tr. 1482:22-1483:4; FF 165.

While all of these additional features of the Mark 2 Posisorter slat perform important functions, that fact does not permit the Mark 2 Posisorter to escape infringement. As the Federal Circuit has held:

An accused device cannot escape infringement by merely adding features, if it otherwise has adopted the basic features of the patent. [citation omitted]. Similarly, an accused device that contains the same feature as the patented device cannot escape infringement because in [sic] that feature performs an additional function it does not perform in the patented device.

Radio Steel & Mfg. Co. v. MTD Products, Inc., 731 F.2d 840, 848 (Fed.Cir.), cert. denied, 469 U.S. 831 (1984) (“Radio Steel”); accord, Amstar Corp. v. Envirotech Corp., 730 F.2d 1476, 1484 (Fed.Cir.), cert. denied, 469 U.S. 924 (1984) (“Amstar”).

Although Vanderlande argues that the slat of the Mark 2 Posisorter is not a right cylinder and therefore has not “adopted the basic features of the patent,” SRB 56, a right cylinder is merely a geometric shape. Vanderlande does not explain how or why the outer wall of its slat does not adopt this geometric shape, or why the additional features and their functions, important as they may be, remove the slat from that geometric shape. Accordingly, the Mark 2 Posisorter system literally satisfies the claim 1 element wherein “each of said slats [are] defined by a wall formed as a right cylinder.”

**d. “An outer surface having a planar upper portion”**

Rapistan and the Staff contend that in the Mark 2 Posisorter system, the wall formed as a right cylinder includes “an outer surface having a planar upper portion

defining said conveying surface” as required by claim 1. CIB 88-91; CRB 72-73; SIB 53-54. The Staff points to the raised projections or ridges on the upper surface of the Mark 2 Posisorter slat as deviations from a purely flat surface. SIB 53. Nevertheless, the Staff contends, a person of ordinary skill in the art would understand “planar upper portion” to encompass surfaces that provide a flat conveying surface, with or without ridges, in contrast to the conveying surface provided by prior art tube-type sorters. SIB 53.

Vanderlande contends that the Mark 2 Posisorter does not meet this limitation. RIB 82-83; RRB 58-59. The ridges on the upper surface of the slat help prevent jams and allow for the sortation of thin packages, such as letters, Vanderlande argues. RIB 82. Secondly, if a container being sorted accidentally spills material (such as maple syrup) on the conveying surface, the ridges reduce the amount of material that falls into the center of the system and damages the sorting mechanism. Id. Thirdly, the drip edge on the rear ridge prevents fluid from dripping into the rear guide channel. Id. Fourth, the ridges provide increased friction when the packages have soft bottoms. Id. Fifth, the ridges provide extra stiffness. Id.

As explained by Rapistan’s expert, Radcliffe, the Mark 2 Posisorter slat has “a planar upper portion” defining the conveying surface. Radcliffe Tr. 810:15-811:10; CDX-9; CDX-23; FF 166. As the claim term “planar upper portion” has been construed in this Initial Determination to mean an overall flat surface that can include some raised portions that deviate from a truly two-dimensional surface, the



ridges on the top surface of the Mark 2 Posisorter slat do not remove it from this claim element.

The ridges have many aspects that enhance the functionality of the upper conveying surface of the Mark 2 Posisorter slat. They help prevent jams and allow for the sortation of thin packages, such as letters. Van den Goor Tr. 1483:13-22; **FF 167**. If a container being sorted accidentally spills material (such as maple syrup) on the conveying surface, the ridges reduce the amount of material that falls into the center of the system and damages the sorting mechanism. Van den Goor Tr. 1480:3-1481:8; **FF 168**. The ridges also provide increased friction when the packages have soft bottoms. Van den Goor Tr. 1480:3-1481:8; **FF 169**. The ridges also provide extra stiffness. Van den Goor Tr. 1480:3-1481:8. However, the mere fact that these additional features enhance the functionality of the conveying surface of the Mark 2 Posisorter does not allow the Mark 2 Posisorter to escape infringement. See Radio Steel, supra; Amstar, supra. Accordingly, the Mark 2 Posisorter system literally satisfies the element requiring the wall formed as a right cylinder to include “an outer surface having a planar upper portion defining said conveying surface.”

**e. “A support portion”**

Rapistan and the Staff contend that in the Mark 2 Posisorter system, the diverter shoes have “a support portion” as required by claim 1. CIB 92-93; CRB 67-69; SIB 54-55; SRB 19-20. This element is met, according to Rapistan and the Staff, by the one-piece, unitarily-molded support portion and divert portion of the Mark 2 Posisorter shoe. CIB 92; SIB 54.

---

Vanderlande contends that the Mark 2 Posisorter does not meet this limitation. RIB 76-78; RRB 53-54. According to Vanderlande, the entire portion of the Mark 2 diverter shoe above the skids performs solely a diverting function and provides no support function because there is no contact between the upper portion of the slat and the diverter shoe. RIB 76.

As properly construed herein, the “support portion” element of claim 1 is the part of the shoe that holds up or serves as a foundation for another portion of the shoe. To serve as a “foundation,” the support portion does not necessarily have to contact the upper conveying surface of the slat. It can provide support in other ways, such as to preserve the configurational structure of the shoe when under force or stress. As the Staff correctly observes, Vanderlande’s contention is mistaken because it “is akin to arguing, with respect to a standing human being, that the thighs provide no support to the upper body because only the feet and not the thighs contact the ground.” SRB 19.

At trial, Rapistan’s expert, Radcliffe, offered an opinion consistent with the foregoing Staff observation that if the front and rear side walls of the Mark 2 Posisorter diverter shoe were cut at the level of the conveying surface just below the top diverting portion of the shoe, as shown in RX-660C, the side walls of the shoe would flex and there would be inadequate alignment for the bearing surfaces. See Radcliffe Tr. 1168:4-1169:24; RX-660C; FF 170. Radcliffe admitted on cross-examination, however, that he never actually cut a Mark 2 Posisorter diverter shoe to see what would happen. See Radcliffe Tr. 1169:23-25; FF 171. Van den Goor of

---

Vanderlande performed that task for illustrative purposes, and showed that when the Mark 2 Posisorter diverter shoe was cut at the level of the conveying surface as Radcliffe had surmised, the walls did not fall apart and the bottom portion of the shoe still had the ability to move back and forth on the slat. See van den Goor Tr. 1476:12-1477:23; Radcliffe Tr. 1170:1-10; RPX-1A; RPX-19; FF 172. To further illustrate this point, van den Goor also cut a second Mark 2 Posisorter diverter shoe just above the skids on the front and rear side walls. See van den Goor Tr. 1477:9-12; RPX-20. In this case, too, the lower portion of the cut-off shoe retained the ability to move back and forth on the slat. See van den Goor Tr. 1478:4-7; RPX-1A; RPX-20; FF 173.

However, in both instances, without the cut-off bottom part, the top part of both of van den Goor's cut-off Mark 2 Posisorter diverter shoes fell onto the slat, making contact with the slat. See van den Goor Tr. 1477:24-1478:3; 1478:8-10; RPX-1A; RPX-19; RPX-20; FF 174. By contrast, the top piece did not do so when the cuts were made on yet a third Mark 2 Posisorter diverter shoe at a point below the level of the skids. See van den Goor 1477:11-16, 1478:15-18; RPX-1A; RPX-21; FF 175. Although Vanderlande presented this evidence to refute Radcliffe's conjecture regarding the flexure of the side walls of the Mark 2 Posisorter shoe in the absence of the top portion, it does not support Vanderlande's position that the side walls provide no "support" for the top of the diverter shoe, as that word is commonly understood. Rather, it proves the opposite; namely, that the walls hold the top portion of the diverter shoe in place and prevent it from falling onto the slat.

Accordingly, as no other aspect of the Mark 2 Posisorter's satisfaction of this claim element is in dispute, the Mark 2 Posisorter system literally satisfies the element requiring each of the diverter shoes to have "a support portion."

**f. "Substantially continuous glide surface surrounding said wall"**

Rapistan contends that in the Mark 2 Posisorter system, the support portion includes "a substantially continuous glide surface surrounding said wall" as required by claim 1. CIB 94-99; CRB 58-63. In this regard, Rapistan maintains, the Mark 2 Posisorter diverter shoe includes a continuous inner wall surface that completely encircles or encompasses the slot. CIB 94. The inner wall also includes protrusions that form areas of contact with the Mark 2 slot. *Id.* The shoe glides along the slot, according to Rapistan, and there is no difference between "gliding" along a slot and "sliding" along a slot as Vanderlande described its own product in its European patent application for the Mark 2 Posisorter design. CIB 95.

According to Rapistan, it is irrelevant whether the upper surface of the Mark 2 Posisorter slot contacts the diverter shoe for the purpose of meeting the "surrounding" requirement of the claim, because this improvement over the preferred embodiment of the '510 patent does not avoid infringement. CIB 95-96; CRB 58-59 and 61-62. Rapistan also maintains that the particular structure of the preferred embodiment of the '510 patent and the Mark 2 Posisorter both utilize a series of protrusions in the glide surface that control reactive forces operating on the shoe, and that in both systems the protrusions utilize the same horizontal surfaces oriented in

the same direction in order to control forces about the long axis of the slat and use the same vertical surfaces oriented in the same direction to control forces acting around a vertical axis. CIB 97-98. Rapistan also contends that the Mark 2 shoe fully encircles the slat, thereby preventing retreat or removal of the slat other than by sliding the shoe off the slat's end, even if the three protrusions on the Mark 2 shoe were ignored. CIB 98-99.

Even if literal infringement of the "glide surface" element of claim 1 were not met, Rapistan argues, the Mark 2 Posisorter would satisfy that claim element under the doctrine of equivalents. CIB 99. The modification of the particular location of contacting surfaces along the inner wall of the shoe represents an insubstantial difference from that claimed and in fact disclosed in the preferred embodiment of the '510 patent, Rapistan maintains, and these contacting surfaces carried on an otherwise non-contacting wall perform the same force controlling operation in an identical fashion; one-to-one correspondents of components is not required for equivalency. CIB 99; CRB 60.

Vanderlande and the Staff contend that the Mark 2 Posisorter does not meet this limitation. RIB 73-75; RRB 50-53; SIB 55-56; SRB 20-21. Vanderlande argues that the diverter shoe of the Mark 2 Posisorter does not contact the upper conveying surface of its slat, which is required by Vanderlande's interpretation of "glide surface surrounding said wall" as contacting all walls of the slat. RIB 73. In particular, Vanderlande maintains, the section of the diverter shoe above the slat is not a glide surface because there is absolutely no contact above the conveying surface, and that

section of the diverter shoe is part of the diverting portion, not the support portion, which must be ignored in determining the location of the claimed glide surface. RIB 73-74. According to Vanderlande, the inventors of the '510 patented invention never considered a non-contacting design as a feature or an improvement of their invention. RRB 51.

Having contact portions only on the side and bottom of the shoe and not on the top conveying surface, according to Vanderlande, is a substantial difference from the invention of the '510 patent because it reduces any damage that a product (such as leaking maple syrup), sand, and other damage due to metal objects (such as a toolbox) can cause to the diverting shoe. RIB 74; RRB 51. [

] This lack of contact also changes the kinematics governing the movement of the diverter shoe, thus creating substantial differences that remove the Mark 2 Posisorter from satisfaction of this claim element under the doctrine of equivalents. RIB 75; RRB 53.

According to the Staff, the Mark 2 Posisorter does not satisfy the element of a "glide surface surrounding said wall" because the entire inner surface of the shoe cannot fairly be described as a "single unitary structure" that resists reactionary forces and permits smooth and easy movement along the slat. SIB 55. Rather, the Staff argues, the contact surfaces in the Mark 2 shoe that serve to resist reaction forces are found on the sides of three protrusions from the inner surface of the shoe. Id. Instead of being an integral part of an inner surface of the shoe consisting of both contact and

non-contact surfaces, the Staff maintains, these protrusions are more fairly described as distinct structural elements that extend from the inner surface. Id. Moreover, because these distinct protrusions “amount to significant discontinuities in the configuration of the inner surface of the Mark 2 shoe,” the Mark 2 shoe does not meet the requirement of a “substantially continuous” glide surface as required by claim 1. SIB 56. The protrusions in the Mark 2 Posisorter, according to the Staff, are not found in the preferred embodiment of the ‘510 patent; therefore, this distinction in the Mark 2 does not by the same token remove the preferred embodiment from coverage by the claim. SRB 20-21.

The parties have stipulated that the Mark 2 Posisorter has no contact between its diverter shoe and its upper conveying surface of the slat during normal usage. FF 68 (First Stipulation No. 69). However, as properly construed herein, the term “glide surface” in claim 1 is merely a two-dimensional surface and does not imply any points of contact or non-contact between the inner surface of the diverter shoe and the outer surface of the slat wall. Points of contact or non-contact between the glide surface and the slat wall are not claimed features of this element of claim 1. Thus, the foregoing distinctions by the parties between the Mark 2 Posisorter and the claimed invention on the basis of points of contact or non-contact between the inner surface of the Mark 2 shoe and the slat wall are irrelevant to a proper infringement analysis in this instance. All that matters to being a “glide surface,” really, is whether the inner surface of the Mark 2 Posisorter shoe (i) moves over or along the surface of the slat in a smooth, effortless manner without pivoting or rolling; and (ii) is two-

dimensional. There is no factual dispute that the Mark 2 Posisorter shoe's inner surface possesses these characteristics. **FF 176.** Ergo, the inner surface of the Mark 2 Posisorter shoe constitutes a "glide surface" as that term is used in claim 1.

Concerning the glide surface's claimed characteristic of being "substantially continuous," neither Rapistan nor Vanderlande dispute that the Mark 2 Posisorter shoe's inner surface satisfies this requirement. **FF 177.** The Staff points out, however, that the inner surface of the Mark 2 Posisorter has spring-like projections off of the ends of the three inward protrusions from the inner surface that come in contact with the slat. See Radcliffe Tr. 851:23-853:22; Hoet Tr. 2035:20-2038:1; CPX-9; CPX-28; **FF 178.** These projections, in Radcliffe's words, perform an "anti-rattle" function and, in the Staff's view, constitute distinct structural elements from the inner surface that are "significant discontinuities" from the configuration of that surface. **SIB 55.** The projections are not found in the preferred embodiment shown in the '510 patent, according to the Staff. **SRB 20-21.**

It is true, as the Staff points out, that these cantilevered projections break away from part of the inner surface of the Mark 2 Posisorter shoe in order to perform their springlike "anti-rattle" function. Therefore, when viewed in a cross-section taken at either lateral end of the diverter shoe, these projections do not appear to be "continuous" with the outline of the glide surface in a strict sense. However, if the cross-section were taken in the middle of the shoe rather than at either lateral end, these projections would not appear at all since they extend inwardly from each lateral end for only 1-½ inches at most, and the outline of the glide surface on that cross-



section would appear to be “continuous.” In any event, the claim limitation at issue is not merely “continuous,” but “substantially continuous,” and claim terms like “substantially” and “about” are considered “broadening usages” that “must be given reasonable scope; they must be viewed by the decisionmaker as they would be understood by persons experienced in the field of the invention.” See Modine Mfg. Co. v. U.S. International Trade Comm., 75 F.3d 1545, 1554 (Fed.Cir.), cert. denied, 518 U.S. 1005 (1996) (“Modine”); accord, Chemical Separation Technology, Inc. v. U.S., 51 Fed.Cl. 771, 782 n.4 (Fed.Cl. 2002) (“Chemical Separation Technology”). The Mark 2 Posisorter diverter shoe is an integrally molded unit in which the projections are integrally formed of plastic with the remainder of the diverter shoe wall. CRB 62. The only evidence in the record of the impact of these projections on infringement is that, in Radcliffe’s expert opinion, they are additional features. See Radcliffe Tr. 853:23-854:4. The preferred embodiment in the ‘510 patent likewise shows unclaimed projections from the “substantially continuous” glide surface, such as “support rib 60” in Figure 9 of the patent, that break the “continuity” of the inner surface of the diverter shoe. See CX-1 (‘510 patent, Fig. 9; col. 3:40-42). There is no evidence in the record that the “substantially continuous” limitation of claim 1 would not be considered by one of ordinary skill in the art to be literally met by a diverter shoe inner surface that includes such features.

As for the claimed feature of the glide surface’s “surrounding said wall,” that term as properly construed herein also does not imply any points of contact or non-contact between the inner surface of the diverter shoe and the outer surface of the slat

wall. Consequently, the distinctions by the parties between the Mark 2 Posisorter and the claimed invention on the basis of points of contact or non-contact on all four sides between the inner surface of the Mark 2 shoe and the slat wall are irrelevant to a proper infringement analysis in this instance. As to whether the inner surface of the Mark 2 Posisorter shoe extends on all sides or encircles the slat so as to cut off communication or retreat by any means other than sliding the shoe off the end of the slat, there is also no factual dispute among the parties. **FF 179.**

Accordingly, the inner surface of the Mark 2 Posisorter shoe literally constitutes a “substantially continuous glide surface surrounding said wall” as those words are properly used in claim 1.

**g. “Substantially the same configuration as said outer surface of said slat”**

Finally, Rapistan contends that in the Mark 2 Posisorter system, the glide surface has “substantially the same configuration as said outer surface of said slat” as required by claim 1. CIB 99-101; CRB 74-75. According to Rapistan, Vanderlande’s Mark 2 Posisorter shoe closely replicates the outer configuration of the slat except in the lower trailing edge. CIB 99. The fins on the top inner surface of the Mark 2 Posisorter diverter shoe correspond to rib 60 in the preferred embodiment of the ‘510 patent configuration, according to Rapistan, and, therefore, closely replicate the surface of the preferred embodiment. CRB 74. Rapistan argues that Vanderlande’s own expert, Hoet, testified at his deposition that the Mark 2 Posisorter shoe “is substantially the same configuration” as the slat. CIB 100. In the

area of the trailing edge of the slat, Rapistan maintains, metal may have been removed from the slat as a cost-saving measure, but the shape of the diverter shoe was left unchanged. *Id.* Rapistan argues that the amount of deviation in this area is “less than fifteen percent,” according to Rapistan’s expert, Radcliffe. *Id.* Even if this claim element were not literally met by the Vanderlande Mark 2 Posisorter shoe and slat, Rapistan argues, it would be met under the doctrine of equivalents because the deviation between the shoe and the slat is an insubstantial difference. CIB 100-101.

Vanderlande and the Staff contend that the Mark 2 Posisorter does not meet this limitation. RIB 83-85; RRB 59-62; SIB 56.<sup>9</sup> According to Vanderlande, there is no glide surface above the slat as it construes claim 1, and therefore no portion of the glide surface has substantially the same configuration as the upper surface of the slat. RIB 83. Even if the portion of the diverter shoe above the slat were considered part of the glide surface, Vanderlande contends, it cannot be viewed as having the same shape as the slat because there are projections coming down from the top of the inner surface of the diverter shoe and ridges on top of the conveying surface of the slat, as well as sharp angles for drip edges at each end of the slat. *Id.* There is, moreover, a significant difference between the lower rear section of the slat and the corresponding part of the diverter shoe, in Vanderlande’s view. RIB 84. Further, Vanderlande argues, Radcliffe’s fifteen-percent estimate of deviation between the

---

<sup>9</sup>The Staff agrees with Vanderlande that the Mark 2 Posisorter does not satisfy this limitation of claim 1, but only on the basis of its view that since the inner surface of the Mark 2 shoe does not qualify as a “glide surface,” therefore the requirement of a glide surface having substantially the same configuration as the outer surface of the slat is not met by the accused product. SIB 56. Thus, the Staff does not directly address this claim limitation.

Mark 2 Posisorter shoe and slat configuration underestimates the real difference because it ignores differences on the top of the slat (i.e., the fins on the shoe and ridges on the slat), at the drip edges, and at the semicircular portion of the rear guide channel. RIB 84. These differences, according to Vanderlande, raise the differences to thirty percent. Id.

Vanderlande further maintains that Rapistan cannot rely on the doctrine of equivalents in this instance, because the claim term “substantially” is not entitled to any range of equivalents. RIB 85; RRB 61-62. Even if the doctrine of equivalents were available to Rapistan, Vanderlande maintains, the differences between the invention of the ‘510 patent and the Mark 2 Posisorter in connection with this limitation are substantial because the Vanderlande design does not rely on the configuration of the slat and shoe to resist rotational forces, as the invention of the ‘510 patent does. Id. Thus, whereas Vanderlande was able to modify the rear bottom wall of the slat to save costs, the shape of the Vanderlande diverter shoe did not have to be modified, whereas a similar change on the invention of the ‘510 patent would also require a modification of the shoe design. Id. Consequently, Vanderlande argues, there is no infringement under the doctrine of equivalents. Id.

Rapistan and Vanderlande agree that the following Vanderlande demonstrative exhibit RDX-44-3 faithfully represents the slat and shoe configuration of the Mark 2 Posisorter:

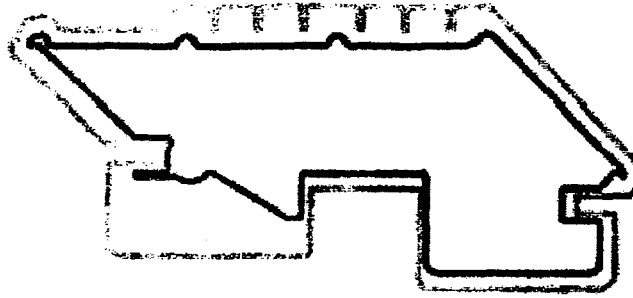

RDX-44-3; **FF 180**. According to Rapistan's expert, Radcliffe, it is important to the invention of the '510 patent that the glide surface have substantially the same configuration as the outer surface of the slat in order to allow the slats to be placed closer together without interference between adjacent divert shoes. Radcliffe Tr. 847:6-14; **FF 181**. It is also important structurally because the glide portion of the slat supports the glide surface better. Radcliffe Tr. 847:15-19; **FF 182**. As for the "substantially" modifier in the claim language, Radcliffe pointed out that the glide surface of the diverter shoe disclosed in the '510 patent does not have exactly the same configuration as the outer configuration of the slat, and that there are in fact a series of protrusions and ribs that differ from the configuration of the slat. Radcliffe Tr. 847:20-848:3; **FF 183**.

According to Radcliffe, the inner surface of the Mark 2 Posisorter diverter shoe "follows relatively closely the outer configuration of the slat" although there are regions in which the configuration is "really quite different," such as the ribs on the top surface of the shoe that are not reproduced on the outer portion of the slat.

Radcliffe Tr. 848:4-21; RDX-44-3; **FF 184**. Nevertheless, according to Radcliffe, as the claim requires only “substantially” the same configuration, it may vary “to a large degree.” Radcliffe Tr. 849:2-8; RDX-44-3; **FF 185**.

Radcliffe also performed a calculation of the amount of deviation of the slat configuration from the configuration of the inner surface of the diverter shoe in the Mark 2 Posisorter, and found that the diagonal portion of the slat in the lower left corner (as shown in RDX-44-3 above) represents approximately 15 percent of the overall perimeter of the slat as measured from the centerline of the slat wall. Radcliffe Tr. 1200:17-25, 1201:10-24; RX-658C; **FF 186**. Although this portion represents a substantial deviation in configuration between the shoe and the slat at that point, according to Radcliffe, the fact that it is under 15 percent means that the overall configuration is nevertheless “substantially the same.” Radcliffe Tr. 1201:25-1202:13; **FF 187**. However, in performing this calculation, Radcliffe did not consider the fins on the upper inner surface of the diverter shoe to be configured differently from the corresponding slat surface; if he had done so, it would have raised the foregoing percentage to as much as 30 percent. Radcliffe Tr. 1205:8-1206:9; **FF 188**.

Vanderlande’s expert, Hoet, testified at trial that the shape of the Mark 2 Posisorter shoe is not substantially the same configuration as the shape of the slat. Hoet Tr. 1851:16-1857:2; 1994:8-18; RDX-18-2; RDX-18-3; RDX-43; RDX-44-2; RDX-44-3; **FF 189**. Hoet pointed to a slat and shoe combination depicted in Figure 12 of the ‘912 patent, which is incorporated by reference into the ‘510 patent,

showing no deviation at all in the configuration of the slat and the shoe. Hoet Tr. 1851:23-1852:17; RDX-18-2; **FF 190**. In the slat and shoe configuration of Figure 10 of the '510 patent, however, Hoet testified that there are areas where the shoe and slat surface deviate. Hoet Tr. 1853:4-11; RDX-43; **FF 191**. In viewing the configuration of the slat and shoe of the Mark 2 Posisorter, Hoet pointed out that the upper inner surface of the shoe has fins sticking downward, which Hoet called "rake tines," and that the slat has ridges and drip edges that are not duplicated on the inner surface of the shoe, all of which he considered to be substantial deviations between the configurations of the slat and the shoe. Hoet Tr. 1855:1-14; **FF 192**.

Consistently with Radcliffe's testimony, Hoet further opined that the Mark 2 slat also has a slanted portion of the lower wall that deviates substantially from the corresponding squared-off corner of the shoe. Hoet Tr. 1855:15-19; **FF 193**. In considering whether Radcliffe's calculation that 15 percent of the outline of the slat deviated from the shoe at that location, Hoet deemed that amount to be substantial, and if the area of the fins on the top inner surface of the shoe were taken into account, the increase of this percentage to 30 percent was considered by Hoet to be substantial as well. Hoet Tr. 1856:4-1857:2; **FF 194**.

The credibility of Hoet's trial testimony was impeached by his deposition, in which he was asked the following question and gave the following answer:

Q: Addressing the shape of the inner surface on the shoe of Complainant's Exhibit B, is that inner surface, whatever you would call that overall inner surface, substantially the same configuration as the outer surface of the slat?

A: Substantially, it is. There are some differences shown in the lower-right forward corner, rear corner where the support part of the shoe deviates from the contour of the slat, and also in the upper part where it is parallel to the upper surface, there is some deviation from the surface of the slat. The rest of it is -- pretty much follows the contours of the slat.

Hoet Tr. 1994:19-1995:17, quoting from Hoet Dep. 197:21-198:11; **FF 195**. Hoet disavowed this deposition testimony at trial, contending that he corrected his answer on the deposition errata sheet. See Hoet Tr. 1995:19-22; **FF 196**. He admitted at trial that the deposition testimony he gave was his opinion at the time, but that after studying a printout of the deposition transcript to make corrections and after having an opportunity to study the Vanderlande shoe in more detail than he had done before, Hoet came to the conclusion that the Mark 2 Posisorter slat and shoe were not substantially the same configuration, that he had misspoken, and that he therefore offered the correction on his errata sheet. Hoet Tr. 1995:23-1997:2; **FF 197**.

As noted earlier herein, a claim term like “substantially” is considered to be a “broadening usage” that “must be given reasonable scope;” such words “must be viewed by the decisionmaker as they would be understood by persons experienced in the field of the invention.” See Modine, supra, 75 F.3d at 1554; accord, Chemical Separation Technology, supra. Although it is “rarely feasible to attach a precise limit” to such terms, “the usage can usually be understood in light of the technology embodied in the invention.” Modine, supra. The “technological scope” of such terms “is dependent on the context of the use of the term and the precision or significance of the measurements used.” Chemical Separation Technology, supra, 51 Fed.Cl. at 782, citing Zoltek Corp. v. U.S., 48 Fed.Cl. 290, 300 (Fed.Cl. 2000) and Eiselstein



---

v. Frank, 52 F.3d 1035, 1040 (Fed.Cir.1995) (“[t]he meaning of the word ‘about’ is dependent on the facts of a case, the nature of the invention, and the knowledge imparted by the totality of the earlier disclosure to those skilled in the art”).

On balance, Hoet’s testimony on this subject does not credibly refute the testimony of Radcliffe. As the depiction of the slat and shoe profile of the Mark 2 Posisorter in RDX-44-3 above demonstrates, the inner surface of the Mark 2 shoe generally follows the outline of the outer surface of the Mark 2 slat such that the shoe fits the slat and is therefore capable of gliding freely and effortlessly across the slat. This is not “an attempt to fit a square peg into a round hole” that “doesn’t fit,” as Vanderlande’s counsel declared during opening argument at trial. See De Matteo Tr. 156:16-18. Rather, in this case, the “peg” -- here, the Mark 2 Posisorter slat -- has several indentations, bumps and ridges, but nevertheless is configured overall to fit into the “hole” -- here, the Mark 2 Posisorter diverter shoe -- snugly and without difficulty.

In terms of the “substantially” modifier of this claim element, the “technology embodied in the invention” of the ‘510 patent in connection with this claim limitation allows the slats to be placed closer together without interference between adjacent divert shoes and allows the structure of the slat to better support the glide surface, as Radcliffe made clear. Also, as both sides acknowledged, the embodiment depicted in Figure 10 of the ‘510 patent shows deviations from an exact identity of configuration between the inner surface of the shoe and the outer surface of the slat, and thereby indicates that the term “substantially” makes room for such deviation in

the claim language. The configurations of the inner surface of the shoe and the outer surface of the slat of the Mark 2 Posisorter serve these same technological purposes, and therefore have “substantially” the same configuration as one another, even though there are differences in configuration between the two of from 15 to 30 percent in their perimeters. For these reasons, in the Mark 2 Posisorter system, the glide surface of the divertor shoe literally satisfies the claim 1 element of having “substantially the same configuration as said outer surface of said slat.”

In the alternative, if it is ultimately determined that the Mark 2 Posisorter system does not literally satisfy this claim element, it nevertheless does so under the doctrine of equivalents. As Radcliffe explained, there is an insubstantial difference between the configuration of the shoe and slat of the Mark 2 Posisorter and the claimed configuration of the glide surface of the shoe of the ‘510 patented invention that is “substantially the same” as the outer surface of the slat. Radcliffe Tr. 850:2-25. This is so because the glide surface of the Mark 2 shoe, like the invention, accomplishes the purpose of allowing the divert shoes to have clearance between one another while allowing the slats to be closely spaced, and also accomplishes the purpose of providing good structural support for the divert portion of the shoe over the top of the slat. Radcliffe Tr. 850:14-25; FF 198.

Vanderlande argues that Rapistan is not entitled to any range of equivalents in connection with the “substantially the same configuration” claim limitation because to do so “would reduce the claims to nothing more than a functional abstract[ ], devoid of a meaningful structural limitation.” RIB 85, quoting Zodiac

Pool Care, Inc. v. Hoffinger Industries, Inc., 206 F.3d 1408, 1416 (Fed.Cir. 2000) (internal quotation marks omitted); RRB 61. However, the Zodiac case does not support the proposition advanced by Vanderlande that just because the claim limitation at issue contains the word “substantially” means that the limitation is not entitled to any range of equivalents. Rather, Zodiac stands for the well-recognized “all-elements rule” of the doctrine of equivalents, to the effect that when an “issued patent contains clear structural limitations, the public has a right to rely on those limits in conducting its business activities. This court will not effectively remove such a limitation under a doctrine designed to prevent ‘fraud on the patent.’” Id. Such “clear structural limitations” can include a claim element that includes the word “substantially” in it. Id.

Here, the expert testimony of Radcliffe offered by Rapistan as evidence under the doctrine of equivalents does not eviscerate the “substantially the same configuration” limitation of claim 1 of the ‘510 patent. That the configurations must be “substantially the same” has been recognized; all that is broadened under the doctrine of equivalents is the degree to which the configurations can deviate from perfect identity. In this regard, Vanderlande has presented no credible testimony contrary to Radcliffe’s, and the fact that the Mark 2 Posisorter satisfies this limitation under the doctrine of equivalents is, therefore, recognized.

Accordingly, in the Mark 2 Posisorter system, the glide surface of the diverter shoe satisfies the claim 1 element of having “substantially the same configuration as

said outer surface of said slat,” both literally as well as under the doctrine of equivalents.

**h. Conclusion as to infringement of ‘510 patent  
claim 1**

For the foregoing reasons, the Vanderlande Mark 2 Posisorter system infringes claim 1 of the ‘510 patent.

**2. Do Respondents’ Mark 2 Posisorter Systems infringe  
claim 4 of the ‘510 patent?**

In order to infringe dependent claim 4 of the ‘510 patent, an accused conveying system must infringe independent claim 1 and, in addition, each of the slats of such system must be “formed by extrusion.” CX-1 (‘510 patent, col. 6:31-32). There is no dispute that the slats of the Vanderlande Mark 2 Posisorter system are made of extruded aluminum. Radcliffe Tr. 860:25-861:15; Hoet Tr. 2070:12-13; CX-214 (at R21826); FF 199. Accordingly, the Vanderlande Mark 2 Posisorter system infringes claim 4 of the ‘510 patent.

**3. Do Respondents’ Mark 2 Posisorter Systems infringe  
claim 13 of the ‘510 patent?**

**a. Undisputed Claim Elements**

The parties do not dispute that the Mark 2 Posisorter system is, as required by claim 13, “a conveying system having a longitudinally moving conveying surface defined by the uppermost ones of a plurality of slats connected in spaced relation with each other in an endless web.” FF 200. They do not dispute that the Mark 2 has

“a plurality of diverter shoes each moveably mounted on one of said slats for lateral movement with respect to said conveying surface.” FF 201.

**b. “Track means”**

As already determined in connection with claim 1, the Mark 2 Posisorter has the element also required by claim 13 of a “track means engaging said diverter shoes for imparting a lateral force to move said diverter shoes laterally to displace product positioned on said conveying surface.”

**c. “A wall having generally planar upper and lower wall portions”**

Rapistan contends that in the Mark 2 Posisorter, “each of said slats [is] defined by a wall having generally planar upper and lower wall portions joined by side wall portions defining joining edges between each of said wall portions,” as required by claim 13. CIB 101-106; CRB 76-80. The upper wall portion of the Mark 2 Posisorter is “generally planar” for the same reasons that it is “planar” for purposes of claim 1, according to Rapistan. CIB 101-102. As for the lower wall portion, Rapistan contends, the preferred embodiment shown in Figure 3 of the ‘510 patent shows that the lower wall portion would admit of greater deviation from a mathematically planar surface than the upper wall portion, because the lower wall portion includes a dramatic deviation in the form of a lateral stabilizing means. CIB 102. Rapistan contends that experts for both parties agree that the term “generally planar . . . lower wall portion” would properly exclude the lateral stabilizing means that may be present in that wall. *Id.*

Rapistan maintains that the lower wall portion of the Vanderlande slat consists only of the lowermost wall of the slat that parallels the upper conveying surface and the channel for the lateral stabilizing means; it does not include the slanted portion in the lower rear of the slat. CIB 103. If the slanted portion is included, however, Rapistan nevertheless contends that the lower wall of the Mark 2 slat has “an overall generally ‘horizontal’ orientation.” CIB 105. Rapistan contends that it is incorrect to include the slanted portion, however, because such a construct is “arbitrary” and produces slat side walls that are dramatically different in length and a trailing side wall that is only roughly half the height of the shoe’s leading side wall. CRB 78-80.

Even if it is found that the Vanderlande slat does not correspond literally to this claim element, Rapistan argues, then it would nevertheless be equivalent because the difference between a “generally planar lower wall portion” and the lower wall of the Vanderlande slat is insubstantial. CIB 106. Rapistan’s equivalence argument is not barred by prosecution history estoppel, Rapistan maintains, because the amendment of this claim during prosecution had nothing to do with the element in question nor did it narrow its scope. CRB 77-78.

Vanderlande does not dispute that the Mark 2 Posisorter has a “generally planar upper wall portion,” but contends that it does not have the claimed “generally planar lower wall portion.” RIB 86-88; RRB 62-64. The lower wall portion of the Mark 2 Posisorter, according to Vanderlande, extends from the front lower corner to the lower end of the rear guide channel, which includes the slanted region. RIB 86.

That wall, Vanderlande contends, is not generally planar, but is instead a complex shape that does not lie in a single plane. RIB 86 and 88. This is particularly evident, Vanderlande maintains, when a series of slats are viewed in profile upside-down. RIB 86-87. Vanderlande also maintains that Rapistan cannot rely on the doctrine of equivalents in this instance because this element was amended and narrowed during prosecution, thereby estopping Rapistan from arguing infringement under the doctrine of equivalents. RIB 88.

The Staff contends that the Mark 2 Posisorter has a “generally planar upper wall portion,” but does not have a “generally planar lower wall portion.” SIB 57-59; SRB 21-22. The Staff defines the beginning of the lower wall at a well-defined rounded corner at the lower front area of the slat, and further defines the wall as extending rearward via a flat wall segment for roughly one third of the slat’s front-to-back width, then turning upward to form a rear-facing vertical wall segment which is part of the channel that functions as a lateral stabilizer, and then, after emerging from the channel, angling upward slightly, passing over a curved segment, finally leveling out at the base of a rear facing channel. SIB 57-58.

The Staff considers the lower wall of the slat of the embodiment of the ‘510 patent to be “almost precisely planar,” except for the protrusion forming part of the lateral stabilizer, which divides the lower wall into two flat co-planar segments of roughly equal length. SIB 58. According to the Staff, it is appropriate to ignore or discount the lateral stabilizer in establishing the bounds of the lower wall of that embodiment. *Id.* By contrast, the Staff notes, the Mark 2 slat wall portion to the rear

of the lateral stabilizer channel is not co-planar with the front wall segment, nor is it flat. Id.

As already determined herein with regard to claim 1, the Mark 2 Posisorter has “an outer surface having a planar upper portion.” Consequently, it also satisfies the broader limitation found in claim 13 that requires “a wall having a generally planar upper . . . wall portion[ ].” FF 202. The only dispute among the parties concerns whether the Mark 2 Posisorter also has “a wall having a generally planar . . . lower wall portion[ ].”

Rapistan’s definition of the “lower wall portion” of the Mark 2 Posisorter slat consists only of the lowermost front part that parallels the upper conveying surface and the three sides that surround the bottom stabilizer channel. See CDX-34, slide 7. Vanderlande’s definition adds the slanted portion to the rear of that, and the Staff’s definition adds the curved rear screw mount and flat upper portion of the rear channel past that. Thus, there is disagreement as to exactly what part of the Mark 2 slat constitutes the “lower portion.”

When referring to the flat, “generally planar” appearance of the upper conveying surface of the slats of the Mark 2 Posisorter, Rapistan’s expert, Radcliffe, considered several slats together. See Radcliffe Tr. 746:9-20, 1194:14-22; FF 203. Upon viewing several slats upside down, Radcliffe admitted that the lower wall portion was not “generally planar” because “[t]here are some places along the bottom where there’s significant dips, if you will, in the surface formed if you put a bunch



of [slats] together.” Radcliffe Tr. 1195:21-1197:1; RDX-78; FF 204. Radcliffe’s opinion was based upon the following demonstrative exhibit:

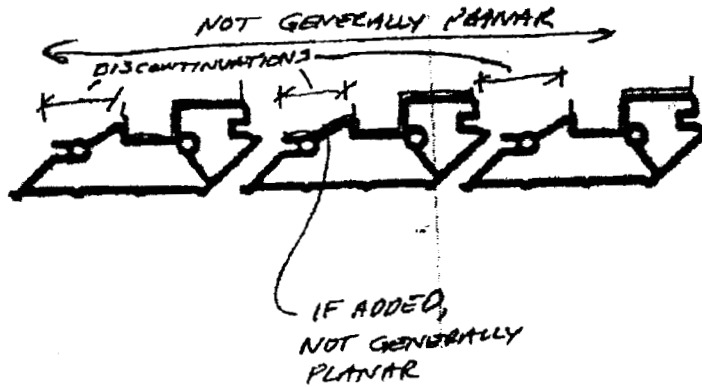

RDX-78; FF 205. Despite this admission, Radcliffe explained his view that the lower wall portion of the Mark 2 slat is “generally planar” by pointing out that his definition of the lower wall is more restrictive than those of Vanderlande and the Staff, and by stating that “the function associated with being generally planar is focused on the strength of the single slat.” Radcliffe Tr. 1197:13-19; FF 206.

When the Mark 2 slat is viewed upside-down in this way, it is evident that the lower wall portion of each slat is not “generally planar.” There is no requirement in the ‘510 patent that the slats must be viewed right-side up in order to determine their “planarity.” Also, contrary to Radcliffe’s unexplained distinction, there is no requirement that the “general planarity” of the lower wall portion must be assessed on the basis of viewing only one slat whereas that of the upper wall portion can be assessed on the basis of viewing a multitude of slats.

If there is any perceptible “planarity” to the lower wall at all, it can be most readily visualized by resort to a definition of the lower wall that is akin to the Staff’s; that is, a lower wall that, when viewing the slat right-side up, extends from the lower protrusion of the rear channel through the top of the stabilizer channel and ends at the top wall of the front channel. See RDX-78. This “planarity,” however, is broken by several discontinuities along the way, as Radcliffe was forced to recognize, including the slanting portion to the rear of the stabilizer channel and the entirety of the lowermost front portion between the stabilizer channel and the front side wall of the slat. Radcliffe was also forced to recognize (and Hoet agreed) that, unlike the lateral stabilizer protrusion of the slat of the ‘510 patent, the lateral stabilizer channel of the slat of the Mark 2 Posisorter does not begin and end in the same plane. Radcliffe Tr. 1199:14-1200:5; Hoet Tr. 1857:13-1858:18; RDX-79; FF 207.

As with the word “substantially” in claim 1, the word “generally” in claim 13 broadens the scope of the claim term “planar” in a way that “can usually be understood in light of the technology embodied in the invention.” Modine, supra, 75 F.3d at 1554. In the embodiment of the invention depicted in the ‘510 patent, the lower wall portion of the slat deviates from “planar” by virtue of its “T-shaped projection 42” that acts as the lateral stabilizing means of the shoe-and-slat combination. See CX-1 (‘510 patent, col. 4:53-61; Fig. 3). That is not the same as the Mark 2 Posisorter slat, which deviates from “planar” in other significant respects, including principally its slanted wall and the projection of all of the lowermost front portion of the wall between the stabilizer channel and the front side wall well beyond

what appears from the upside-down view of the slat to be the common plane of the lower wall portion. See RDX-78; FF 208. Thus, viewing the “generally planar . . . lower wall portion[ ]” element of claim 13 “in light of the technology embodied in the invention,” it cannot be said that the Mark 2 Posisorter slat literally satisfies this element.

The differing views of the parties as to exactly what constitutes the lower wall portion of the Mark 2 slat does not alter this analysis. Under even the most restrictive definition used by Rapistan, the lower wall is anything but planar; no two portions of the lower wall of the Mark 2 slat lie in the same plane. See Radcliffe Tr. 1199:4-1200:5; Hoet Tr. 1858:6-14, 1858:22-1859:1; RPX-1A; FF 209. Rather, the lower wall as Rapistan defines it exists in four separate planes formed by the lowermost forward part and the three walls of the stabilizer channel. See CDX-34, slide 7; FF 210. The definitions used by Vanderlande and the Staff merely add more distinctly separate planes of differing orientations to the mix.

Rapistan attempts to characterize the lower wall of the Mark 2 slat as “generally planar” in that it follows the general orientation of a hypothetical planar surface lying horizontally through the middle of the configuration of the actual wall. See Radcliffe Tr. 869:16-870:13; CPX-34, slide 7. This argument is not persuasive. Rapistan cannot assert infringement against Vanderlande on the basis of a hypothetical accused product; it must prove its case on the basis of the actual accused product. Cf. Laitram Corp. v. Cambridge Wire Cloth Co., 919 F.2d 1579, 1581 n.7 (Fed.Cir. 1990) (courts do not decide hypothetical cases or controversies; noting trial

court's colloquy with counsel that "[y]ou don't go out and create hypothetical products and ask the district court to rule on infringement by a hypothetical product.").

Not only does the lower wall portion of the Mark 2 Posisorter slat fail to satisfy the "generally planar" limitation literally; it also fails under the doctrine of equivalents. In the Mark 2 slat, according to Radcliffe, the lowermost wall of the slat is thicker than the rest of the wall because Vanderlande was concerned about the stiffness of the slat, and longer slats are stiffened by increasing the thickness of that wall. Radcliffe Tr. 870:14-871:3. Likewise, the purpose of having a "generally planar" lower wall is to provide structural stiffness to the closed shape of the slat, and the way to achieve such stiffness is by concentrating as much material away from the central axis as possible within the lower portion of the closed shape. Radcliffe Tr. 869:16-870:13; 871:18-872:13. Rapistan argues, therefore, that there is an insubstantial difference between the function of the claimed "generally planar . . . lower wall portion[ ]" of the invention of the '510 patent and that of the thickened portion of the lower wall of the Mark 2 slat.

Other than this conclusory expert testimony, Rapistan offers no rationale as to why the "generally planar" configuration of the lower wall portion of the slat claimed in the '510 patent affords substantially the same stiffness to the slat wall that a thickened wall provides in the Mark 2 Posisorter slat, such that a person of ordinary skill in the art would be led to conclude that the differences in function, way and result between the two are insubstantial. See Texas Instruments Inc. v. Cypress

Semiconductor Corp., 90 F.3d 1558, 1567 (Fed.Cir.1996) (“Generalized testimony as to the overall similarity between the claims and the accused infringer’s product or process will not suffice.”); Lear Siegler, Inc. v. Sealy Mattress Co., 873 F.2d 1422, 1426 (Fed.Cir.1989) (infringement under the doctrine of equivalents must be established with “particularized testimony and linking argument”). There is nothing in the ‘510 patent that says that the purpose of having a generally planar lower wall is to enhance stiffness or to concentrate material away from the center axis of the slat. Moreover, contrary to Radcliffe’s view of the Mark 2 slat, its lower wall includes inwardly projecting channels and an upwardly-sloping wall in addition to the thickened lowermost wall, and therefore does not concentrate material away from the center axis, but instead adds material closer to the center axis. See RPX-1A; FF 211. Accordingly, Rapistan’s arguments as to why the Mark 2 slat satisfies the “generally planar” limitation of claim 13 under the doctrine of equivalents, if not literally, are without merit.<sup>10</sup>

Accordingly, the Mark 2 Posisorter satisfies the requirement of claim 13 that “each of said slats [is] defined by a wall having generally planar upper . . . wall portions,” but does not satisfy the requirement that “each of said slats [is] defined by a wall having generally planar . . . lower wall portions,” that are “joined by side wall portions defining joining edges between each of said wall portions.”

---

<sup>10</sup>Since Rapistan’s argument under the doctrine of equivalents fails, it is unnecessary to consider Vanderlande’s contention that the doctrine of equivalents is barred by prosecution history estoppel.

**d. "A support portion"**

As already determined in connection with claim 1, the Mark 2 Posisorter has the element also required by claim 13 consisting of "a support portion."

**e. "A glide surface surrounding said wall"**

As already determined in connection with claim 1, the Mark 2 Posisorter has the element also required by claim 13 consisting of a "a glide surface surrounding said wall." Claim 13 does not require this glide surface to be "substantially continuous" as required by claim 1.

**f. "Bearing means"**

Rapistan contends that the Mark 2 Posisorter has the claim 13 requirement of a "bearing means defining a bearing between at least one of said joining edges of each of said slats and an engaging portion of said glide surface of the corresponding one of said diverter shoes." CIB 106-108; CRB 80-82. The bearing means on the Mark 2 Posisorter upon which Rapistan relies is located at the trailing end of the lower wall portion as Rapistan defines it, and is depicted as follows:

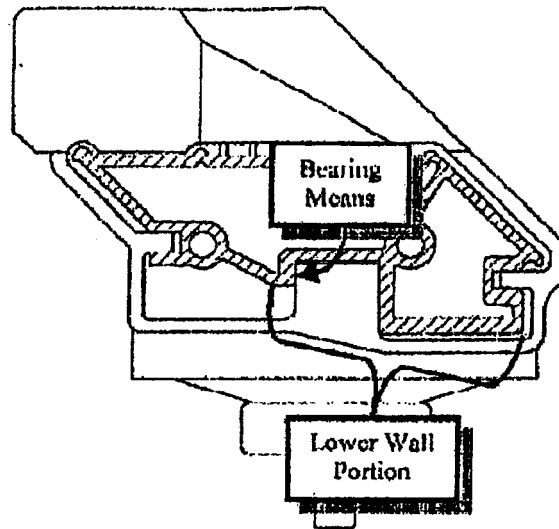

CIB 107. As Rapistan notes, the sliding surface bearing of the lateral stabilizing means is also positioned at this joining edge. CIB 107. According to Rapistan, enlarged radius corners are not necessary to meet the bearing means requirement of claim 13, and a joining edge encompasses the region in the vicinity of the border between wall portions. CRB 80. Even if the lower wall portion of the Mark 2 slat were interpreted to extend up along the sloped side wall portion to the guide tab in that side wall, Rapistan argues, a bearing satisfying this claim element would be found at the lower surface of the U-channel on the trailing side of the slat. CIB 107-08. Further, it is asserted that even if the bearing means of the accused slat were found not to respond literally to claim 13, it would still infringe under the doctrine of equivalents because the Mark 2 bearings transfer forces in a manner that is insubstantially different from the device disclosed in claim 13. CIB 108.

Vanderlande and the Staff contend that the Mark 2 Posisorter does not meet this limitation. RIB 89-91; RRB 64-66; SIB 59-60; SRB 22-23. According to Vanderlande, the Mark 2 Posisorter slats and diverter shoes do not have enlarged radius corners, and there is absolutely no engagement at any of the joining edges of the Mark 2. RIB 89. Further, in Rapistan's concept of the bearing means depicted above, the contact for such a bearing is located only along a portion of the lower wall of the slat, not at a joining edge as required by the claim, Vanderlande maintains. RIB 89-90. Further, Vanderlande argues, Rapistan identifies the same structure for the bearing means as for the lateral stabilizing means of claim 17, which cannot be between a "joining edge" and the glide surface as required by claim 13 at the same time that it is between a "wall portion" and the glide surface as required by claim 17. RIB 90. According to Vanderlande, a point on the slat is either a wall portion or a joining edge; it cannot be both. RRB 65. This fact also precludes Rapistan from relying on the doctrine of equivalents, Vanderlande contends, because to allow the same structure to fulfill two conflicting claim elements would vitiate one such limitation and thereby run afoul of the all-limitations rule. RRB 66. Finally, Vanderlande argues, the structure identified by Rapistan as the "bearing means" does not function the same as the claimed bearing means because the bearing means resists reaction forces about the long axis of the slat, whereas the lateral stabilizer resists forces about the vertical axis of the shoe. RIB 90-91.

According to the Staff, the "bearing means" limitation requires that at least one of the contact surfaces of the shoe's glide surface engage the slat at an outside



corner of the slat. SIB 59. The Mark 2 Posisorter, instead of using rounded corners to create the bearing surfaces that permit gliding of the shoe across the slat as in the '510 patent, uses channels on the slat and corresponding protrusions from the shoe for guiding movement of the shoe along the slat and for resisting rotational forces. Id. Thus, the Staff argues, the “bearing means” limitation is not met by the Mark 2 Posisorter, either literally or under the doctrine of equivalents, because it requires contact between a joining edge (i.e., a corner) of the slat and a corresponding surface on the shoe, and there is no point of contact between the Mark 2 shoe and slat at any of the four intersections of the various slat wall portions. Id. In the Staff’s view, in the context of the '510 patent, contact between the shoe and slat “in the vicinity” of a joining edge is not substantially equivalent to contact “at” a joining edge. SIB 59-60; SRB 22-23.

The arguments of each party as to the presence or absence of a “bearing means” in the Mark 2 Posisorter turns on each party’s definition of the “lower wall portion” of the Mark 2 slat. Taking Rapistan’s definition first, see CDX-34, slide 7, it is Rapistan’s position that the short vertical trailing segment of the lower wall portion of the Mark 2 slat is a “joining edge” that defines a bearing between that wall segment and the “engaging portion” of the lateral stabilizer surface of the diverter shoe. See Radcliffe Tr. 878:20-879:20, 1209:24-1214:13; RDX-81. This “joining edge” was delineated by Radcliffe on demonstrative exhibit RDX-81 as item “B” as follows:

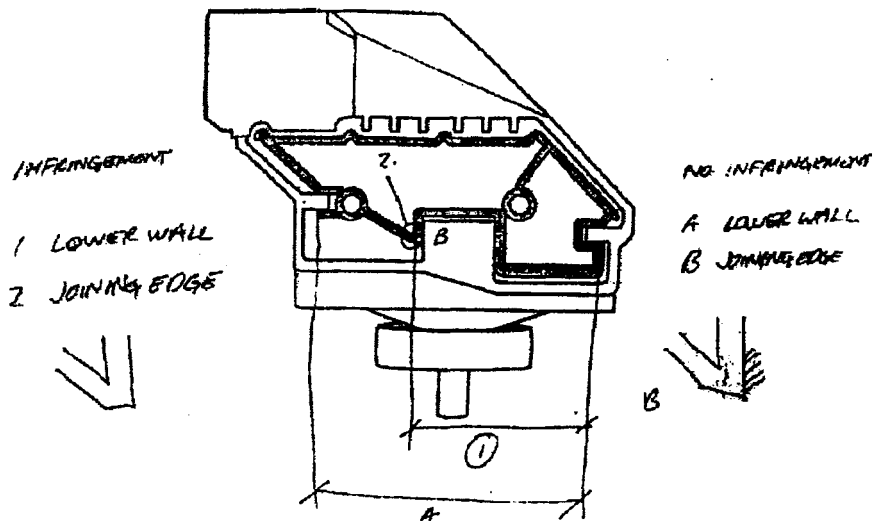

See RDX-81; FF 212. This purported “joining edge” is a small region of the wall itself, which, according to Radcliffe, has some thickness and therefore is not a mathematical point. See Radcliffe Tr. 1212:25-1213:8; RDX-81; FF 213. The two surfaces in contact with one another that form this “bearing means,” Radcliffe opines, consist of the vertical forward-facing surface of the slat in this region and the opposing vertical rearward-facing surface on the lateral stabilizer of the diverter shoe. See Radcliffe Tr. 879:14-20; FF 214. Contact between these surfaces, according to Radcliffe, occurs entirely to one side of the small vertical wall segment and does not occur at the corner where that segment meets the slanted wall portion. See Radcliffe Tr. 1212:25-1213:8, 1213:15-22; RDX-81; FF 215.

Radcliffe conceded at trial that no contact occurs between the Mark 2 slat and shoe (i) at the upper front corner where the front side wall of the slat meets the upper

wall portion (Radcliffe Tr. 1209:9-13); (ii) at the upper rear corner where the rear side wall of the slat meets the upper wall portion (Radcliffe Tr. 1209:14-15); (iii) at the lower front corner where the front side wall of the slat meets the “lower wall portion” (as all parties define that term in relation to the Mark 2) (Radcliffe Tr. 1209:16-18). **FF 216.** Moreover, since Radcliffe’s definition of the “lower wall portion” does not include the part of the wall extending from the bottom of the rear stabilizer channel wall and slanting upward to the rear U-shaped channel, he therefore found no contact in that region either. Radcliffe Tr. 1209:19-23; **FF 217.** Thus, Rapistan’s expert conceded that if the “lower wall portion” of the Mark 2 slat is defined as either Vanderlande or the Staff define it, then there is no “bearing means” element between any joining edge of the lower wall portion of the Mark 2 slat as so defined and the glide surface of the corresponding Mark 2 shoe.

As determined earlier herein, the element in claim 13 wherein the lower wall portion is “joined by side wall portions defining joining edges between each of said wall portions” has been construed to mean that at a point where either an upper or lower wall portion of a slat meets a side wall portion of the slat, a line at the intersection of the two walls is formed between them that includes a small region adjacent to that line on each wall surface. Under Rapistan’s definition, the point indicated by Radcliffe is a “joining edge” because what Radcliffe calls the “lower wall portion” meets the “rear side wall” of the slat at that point.

Vanderlande’s expert, Hoet, disagrees that this point is a “joining edge” because it is not located at a “corner” where the lower wall portion and a side wall

of the Mark 2 slat meet. See Hoet Tr. 1814:22-1815:6. Vanderlande also argues that the “joining edge” advocated by Rapistan also does not function in conjunction with the engaging portion of the glide surface of the shoe as a “bearing means” because the purpose of the claimed structure, as stated in the specification of the ‘510 patent, is to “resist reaction forces about the long axis C of the slats (see Fig. 9).” RIB 90-91; also see CX-1 (‘510 patent, col. 4:65-66).

Rapistan’s view that this point of contact between the Mark 2 slat and shoe is a “bearing means” under claim 13 is unpersuasive. As already noted, Rapistan’s definition of the “lower wall portion” of the Mark 2 slat fails because it is not “generally planar” as claim 13 requires. Accordingly, since a “joining edge” is defined by the claim as a point where either the upper or lower wall portions of the slat meet a side wall of the slat, point “B” cannot be a “joining edge.”

The purpose of a “bearing means” in the invention, as stated frequently in the written description of the patent, is to “resist reaction forces about the long axis C of the slats.” See CX-1 (‘510 patent, cols. 1:66-2:2, 3:43-51; 4:63-5:1). This purpose is not incorporated as such into the wording of claim 13, and therefore is not a requirement of claim 13 that an accused device must satisfy in order to be covered by the “bearing means” claim element. See Laitram Corp. v. NEC Corp., supra, 163 F.3d at 1347 (“[A] court may not import limitations from the written description into the claims.”); also see Honeywell, Inc. v. Victor Co., 298 F.3d 1317 (Fed.Cir. 2002) (“The fact that the patentee chose to include language in claim 1 relating to only one of the two cited prior art problems is persuasive evidence that the claim does not

require the solution of both problems.”). Nevertheless, it is worth noting that Rapistan’s contention, if adopted, would lead to an anomalous result that is not in keeping with the ‘510 patent’s stated purpose for a “bearing means.”

Rapistan’s expert, Radcliffe, was cross-examined at some length during trial regarding the differing reaction forces that are experienced in both the Mark 2 slat (as shown in Exhibit RDX-77) and the slat of the invention of the ‘510 patent (as shown in Exhibit RDX-76) as a result of rotations of the shoe along its vertical axis (i.e., axis B in Figure 8 of the ‘510 patent) and the lateral or “long” axis of the slat (i.e., axis C in Figure 8 of the ‘510 patent). See CX-1 (‘510 patent, Fig. 8); Radcliffe Tr. 1351:2-1352:21; RDX-76; RDX-77. It was demonstrated during that cross-examination that rotation of the Mark 2 shoe about the long axis of the Mark 2 slat produced reaction forces at certain points in the slat (identified as reaction forces “A” through “D”) that corresponded to points in the slat of the ‘510 invention, and that rotation of the Mark 2 shoe about its own vertical axis produced reaction forces at different points in the slat (identified as reaction forces “E” and “F”) that corresponded to points in the slat of the ‘510 invention. See RDX-76; RDX-77; FF 218. However, at the point in the Mark 2 slat where Rapistan contends that a “bearing means” is present, only reaction forces caused by rotations around the vertical axis (i.e., reaction forces “E” and “F”) were shown to exist. See Radcliffe Tr. 1351:2-1352:21; RDX-77; FF 219. Although these forces at this point were shown to correspond to a “lateral stabilizing means” that is required by claims 17 and 23 of the ‘510 patent to resist “vertical-axis reaction-force-couples,” there is no evidence

in the record to demonstrate that this point is also the location of forces resisting rotation along the long axis of the slat as well, as a “bearing means” is meant to do.

Rapistan has also failed to show that the “bearing means” element of claim 13 is satisfied by the Mark 2 Posisorter under the doctrine of equivalents, if not literally. The only reason given by Rapistan as to why Mark 2 Posisorters meet this limitation by equivalence is that “they still transfer forces” like the invention of the ‘510 patent. See Radcliffe Tr. 880:18-25. However, as explained above, the difference between the transfer of forces at Rapistan’s purported Mark 2 “bearing means” and at the “bearing means” of the embodiment of the invention disclosed in the ‘510 patent is a substantial one, basically the difference between the forces caused by rotation about the long axis of the slat and by rotation about the vertical axis of the shoe. Further, Rapistan’s equivalence argument does not give any reason as to why the point at which its purported “lower wall portion” of the Mark 2 slat meets the purported “side wall” of that slat should be deemed equivalent to the point at which a “joining edge” is formed in the invention of the ‘510 patent. Rapistan cannot merely gloss over this claim limitation under the guise of the doctrine of equivalents. See Hogan AB v. Dresser Industries, Inc., 9 F.3d 948, 954 (Fed. Cir. 1993) (Patentholder “is not entitled to a range of equivalents which would erase meaningful structural and functional limitations of the claim on which the public is entitled to rely in avoiding infringement.”) (internal quotation marks omitted).

Accordingly, Rapistan’s position that the Mark 2 shoe and slat satisfy the “bearing means” element of claim 13 must be rejected. Further, inasmuch as

Rapistan concedes that the Mark 2 has no “bearing means” under the definitions of the Mark 2 slat’s “lower wall portion” propounded by Vanderlande and the Staff, it therefore has not been demonstrated that the Mark 2 satisfies this claim limitation at all.

**g. Conclusion as to infringement of ‘510 patent claim 13**

For the foregoing reasons, the Vanderlande Mark 2 Posisorter system does not infringe claim 13 of the ‘510 patent.

**4. Do Respondents’ Mark 2 Posisorter Systems infringe claim 17 of the ‘510 patent?**

**a. “Means defining lateral stabilizing means”**

Rapistan contends that the Mark 2 Posisorter meets all of the limitations of independent claim 13 and, in addition, satisfies the additional limitation of dependent claim 17 in that it “includ[es] means defining lateral stabilizing means between one of said wall portions of each of said slats and an engaging portion of said glide surface of the corresponding one of said diverter shoes, said lateral stabilizing means resisting vertical-axis reaction-force-couples.” CIB 108-110; CRB 82-83. According to Rapistan, the Mark 2 utilizes mating sets of vertical walls formed by a channel and protrusion on the slat and shoe lower region. CIB 108. These mating vertical walls, Rapistan argues, utilize a relatively high length-to-width ratio that is in excess of the preferred five-to-one ratio disclosed in the ‘510 patent. CIB 109. According to Rapistan, it is irrelevant to the force couple resisting operation of the Mark 2 structure that the vertical walls on the slat extend inwardly or outwardly. CIB 109-

---

110. Further, Rapistan argues, neither the Mark 2 Posisorter lateral stabilizer's lack of a "T"-shape nor the debris clearance between shoe and slat would be necessary to perform the lateral stabilizer function. CRB 83.

Vanderlande contends that the Mark 2 Posisorter does not satisfy claim 13 and does not meet the additional limitation of claim 17 either. RIB 91-93; RRB 66-67. Vanderlande agrees that the upward rectangular projection with a 6:1 length-to-width ratio arising from the bottom of the diverter shoe and the channel at the bottom of the slat performs the function of resisting vertical axis reaction forces. RRB 66. However, according to Vanderlande, the Mark 2's upward rectangular (not "T"-shaped) projection rising (not descending) from the bottom of the inner surface of the diverter shoe (not the slat) and extending upward into an upside-down recess of the slat is not the same or equivalent structure to the embodiment disclosed in the '510 patent. RIB 91. These structural differences from the embodiment of the '510 patent are substantial, according to Vanderlande. *Id.* The inventors of the '510 patent rejected a rectangular projection, according to Vanderlande. RIB 91. Also, Vanderlande argues, by having contact points for the lateral stabilizer that are upward and internal to the slat rather than downward and outside as in the invention of the '510 patent, the forces in the Mark 2 Posisorter are reversed completely. *Id.* Further, by positioning the projection up into the slat, the Mark 2 Posisorter shoe does not need a clearance at the bottom of the channel to provide debris tolerance as required by the claimed stabilizer. *Id.* However, Vanderlande contends, because the Mark 2 Posisorter uses a recess on the underside of the slat, an additional closed deck



---

structure is required between the slats making up the conveying surface and the slats returning on the bottom of the conveyor to prevent debris from falling onto the channel. Id. The '510 stabilizer, which projects outward, does not require a closed deck system, Vanderlande maintains. Id.

The Staff contends that the Mark 2 Posisorter satisfies the additional limitation of claim 17, as discussed earlier herein, but since the Mark 2 does not meet all of the limitations of claim 13, it therefore does not satisfy claim 17. SIB 60-62. According to the Staff, the primary difference between the accused device and the corresponding structure in the '510 patent is the reversal in orientation, in that the '510 patent describes a downward protrusion from the slat into the shoe, while the Mark 2 uses an upward protrusion from the shoe into the slat. SIB 60. Additionally, the Staff maintains, the "T"-shaped protrusion in the '510 patent differs from the rectangular protrusion in the Mark 2. Id. Finally, according to the Staff, while the embodiment in the '510 patent has an approximately five-to-one length-to-width ratio in the channel, the length-to-width ratio in the Mark 2 is approximately six or seven-to-one. SIB 60-61. These differences, according to the Staff, are insubstantial so that the lateral stabilizer of the Mark 2 is an "equivalent structure" to the lateral stabilizer described in the specification of the '510 patent. SIB 61. The Staff points out that the Mark 2's lateral stabilizer works the same way as the '510 patent's lateral stabilizer to resist vertical-axis reaction forces by providing two vertical walls between the shoe and slat. SIB 61. According to the Staff, a person of ordinary skill in the art would understand that while the '510 patent specifies an approximately five-to-one

length-to-width ratio, a higher ratio would increase the effectiveness of the lateral stabilizer, and thus the slightly higher ratio of the Mark 2 is not a significant difference. Id. As for the “T” shape of the protrusion in the ‘510 patent, the Staff argues, this does not affect the functioning of the lateral stabilizing device, nor does the specification identify any reason for constructing the lateral stabilizer with a T-shape as opposed to a rectangular projection. Id. Thus, the Staff argues, the rectangular projection of the Mark 2 is equivalent to the “T”-shaped protrusion of the ‘510 patent. Id. Further, the Staff argues, the protrusion and channel arrangement of the Mark 2 Posisorter is located in the same area on the center of the underside of the slat as in the invention of the ‘510 patent, and accomplishes the function of lateral stabilization in substantially the same way as the protrusion and channel arrangement of the ‘510 patent. SIB 62. Thus, the Staff argues, this limitation is literally met by the accused product under 35 U.S.C. § 112, ¶ 6, but claim 17 is not infringed because claim 13 from which it depends is not infringed. Id.

The parties agree that the Mark 2 Posisorter has a lateral stabilizer consisting of a protrusion and a mating channel creating a pair of vertical walls that are on the lower part of the shoe and slat, which resist rotation about the vertical axis of the shoe, and have at least a shoe length-to-shoe width ratio of 6:1 that is better for stabilization than the 5:1 ratio of the embodiment disclosed in the ‘510 patent. See Radcliffe Tr. 1249:7-23; Hoet Tr. 2038:12-2039:6; **FF 220**. Vanderlande concedes that the Mark 2 lateral stabilizer performs the claimed function of the element of claim 17. RRB 66. Vanderlande disputes only that the Mark 2 lateral stabilizer is not

an equivalent structure to the embodiment of the '510 patent, and to that extent its argument fails. The only structural distinctions noted between the lateral stabilizer of the Mark 2 and the lateral stabilizer of the invention of the '510 patent is that: (i) the projection is rectangular instead of "T"-shaped; (ii) the projection is upward from the shoe and inward to the slat instead of downward from the slat and inward to the shoe; and (iii) no clearance for "debris tolerance" is necessary. These structural differences, however, are totally superfluous to the structures that are necessary to perform the claimed function of lateral stabilization, which is performed only by: (i) the mating of the vertical walls of the slat and the shoe, and (ii) the length-to-width shoe ratio of more than 5:1. As noted above, the lateral stabilizer of the Mark 2 Posisorter literally possesses these structures. Thus, the lateral stabilizer of the Mark 2 Posisorter is an equivalent structure to the lateral stabilizer of the invention of the '510 patent that performs the same function as the structure of the invention.

**b. Conclusion as to infringement of '510 patent  
claim 17**

Accordingly, the Mark 2 Posisorter literally satisfies the element of claim 17 wherein the conveying system of claim 13 "further includ[es] means defining lateral stabilizing means between one of said wall portions of each of said slats and an engaging portion of said glide surface of the corresponding one of said diverter shoes, said lateral stabilizing means resisting vertical-axis reaction-force-couples." However, since the Mark 2 Posisorter does not infringe independent claim 13 from which claim 17 depends, it therefore does not infringe claim 17.

**5. Do Respondents' Mark 2 Posisorter Systems infringe claim 20 of the '510 patent?**

In order to infringe dependent claim 20 of the '510 patent, an accused conveying system must infringe independent claim 13 and, in addition, the support portion must be "molded of a polymeric material." CX-1 ('510 patent, col. 7:33-34). There is no dispute that the diverter shoes of the Vanderlande Mark 2 Posisorter system are made of a polymeric material. Radcliffe Tr. 940:2-12; Hoet Tr. 2070:9-11; CPX-9; FF 221. However, since the Vanderlande Mark 2 Posisorter system does not infringe claim 13, it therefore does not infringe claim 20.

**6. Do Respondents' Mark 2 Posisorter Systems infringe claim 22 of the '510 patent?**

In order to infringe claim 22 of the '510 patent, an accused conveying system must infringe claims 13 and 20 and, in addition, the diverter shoe's support portion must be "defined by a multiplicity of joined wall segments having substantially the same thickness." CX-1 ('510 patent, col. 7:37-39). The language of this claim is not disputed, nor is it disputed that the Mark 2 Posisorter satisfies this limitation. See Radcliffe Tr. 944:5-947:8; Hoet Tr. 2074:22-2075:3; FF 222. There is also no dispute that the Mark 2 Posisorter satisfies the limitation of claim 20, as discussed earlier herein. However, since the Vanderlande Mark 2 Posisorter system does not infringe claim 13, it therefore does not infringe claim 22.

**7. Do Respondents' Mark 2 Posisorter Systems infringe claim 23 of the '510 patent?**

Independent claim 23 recites a combination of elements that appear in, and have already been construed in connection with, earlier claims. Accordingly, it is

unnecessary to recount the positions of the parties on each element in stating the outcome as to each element.

**a. Undisputed Claim Elements**

The parties do not dispute that the Mark 2 Posisorter system is, as required by claim 23, “a conveying system having a longitudinally moving conveying surface defined by the uppermost ones of a plurality of slats connected in spaced relation with each other in an endless web.” **FF 223**. They do not dispute that the Mark 2 has “a plurality of diverter shoes each moveably mounted on one of said slats for lateral movement with respect to said conveying surface.” **FF 224**.

**b. “Track means”**

As already determined in connection with claims 1 and 13, the Mark 2 Posisorter has the element also required by claim 23 of a “track means engaging said diverter shoes for imparting a lateral force to move said diverter shoes laterally to displace product positioned on said conveying surface.”

**c. “A wall having generally planar upper and lower wall portions”**

As already determined in connection with claim 13, the Mark 2 Posisorter satisfies the requirement also recited in claim 23 that “each of said slats [is] defined by a wall having generally planar upper . . . wall portions,” but does not satisfy the requirement that “each of said slats [is] defined by a wall having generally planar . . . lower wall portions,” that are “joined by side wall portions defining joining edges between each of said wall portions.”

**d. “A support portion”**

As already determined in connection with claims 1 and 13, the Mark 2 Posisorter has the element also required by claim 23 consisting of “a support portion.”

**e. “A glide surface surrounding said wall”**

As already determined in connection with claims 1 and 13, the Mark 2 Posisorter has the element also required by claim 23 consisting of a “a glide surface surrounding said wall.” Claim 23, like claim 13, does not require this glide surface to be “substantially continuous” as required by claim 1.

**f. “Means defining lateral stabilizing means”**

Finally, as already determined in connection with claim 17, the Mark 2 Posisorter has the element also required by claim 23 consisting of a “means defining lateral stabilizing means between one of said wall portions of each of said slats and an engaging portion of said glide surface of the corresponding one of said diverter shoes, said lateral stabilizing means resisting vertical-axis reaction-force-couples.”

**g. Conclusion as to infringement of ‘510 patent claim 23**

For the foregoing reasons, the Vanderlande Mark 2 Posisorter system does not infringe claim 23 of the ‘510 patent.

**8. Do Respondents’ Mark 2 Posisorter Systems infringe claim 27 of the ‘510 patent?**

In order to infringe dependent claim 27 of the ‘510 patent, an accused conveying system must infringe independent claim 23 and, in addition, the support

portion must be “molded of a polymeric material.” CX-1 (‘510 patent, col. 8:3-4). It has already been determined in connection with claim 20 that the diverter shoes of the Vanderlande Mark 2 Posisorter system are made of a polymeric material. However, since the Vanderlande Mark 2 Posisorter system does not infringe claim 23, it therefore does not infringe claim 27.

**9. Do Respondents’ Mark 2 Posisorter Systems infringe claim 29 of the ‘510 patent?**

In order to infringe claim 29 of the ‘510 patent, an accused conveying system must infringe claims 27 and 23 and, in addition, the diverter shoe’s support portion must be “defined by a plurality of joined wall segments having substantially the same thickness.” CX-1 (‘510 patent, col. 8:7-8). As has already been determined in connection with claim 22, the language of this claim is not disputed, nor is it disputed that the Mark 2 Posisorter satisfies this limitation. It has also been determined already that the Mark 2 Posisorter satisfies the limitation of claim 27. However, since the Vanderlande Mark 2 Posisorter system does not infringe claim 23 (and therefore does not infringe claim 27 either), it therefore does not infringe claim 29.

**10. Do Respondents’ Mark 2 Posisorter Systems infringe claim 30 of the ‘510 patent?**

**a. Undisputed Claim Elements**

The parties do not dispute that the Mark 2 Posisorter system has, as required by claim 30, “a diverter shoe for use in a conveyor system having a longitudinally moving conveying surface defined by the uppermost ones of a plurality of slats connected in spaced relation with each other in an endless web.” FF 225.

**b. "Track means"**

Consistent with the determinations already made for claims 1, 13 and 23, the Mark 2 Posisorter has the element required by claim 30 of a "track means extending below said uppermost ones of said slats for engaging and imparting a lateral force to displace selected ones of said diverter shoes laterally with respect to said conveying surface." **FF 226.**

**c. "A support member"**

It has already been determined in connection with claims 1, 13, 20, 22, 23, 27 and 29 that the Mark 2 Posisorter has "a support portion," and as construed herein, that element is the same as claim 30's requirement of "a support member." **FF 227.**

**d. "A glide portion . . ."**

Rapistan contends that the diverter shoe of the Mark 2 Posisorter has a support member having "a glide portion including means defining a glide surface adapted to glide along one of said slats" as required by claim 30. CIB 112; CRB 63-66. This claim, Rapistan maintains, does not require the shoe's glide surface to surround the slat. CIB 112; CRB 66. It is also unnecessary, according to Rapistan, to interpret this "means plus function" element to incorporate all of the components of the embodiment of the '510 patent into the claim, particularly those elements connected with the slat rather than the shoe. CRB 63-65. This element also literally encompasses the protrusions on the two sides of the Mark 2 diverter shoe's inner surface that Vanderlande refers to as "skids," Rapistan contends. CRB 65.



Vanderlande and the Staff contend that the Mark 2 Posisorter does not meet this limitation. RIB 75-76; SIB 65-67. Vanderlande points out that this limitation is governed by 35 U.S.C. § 112, ¶ 6, and as such covers a glide surface surrounding the slat having a bearing means with enlarged radius corners; a lateral stabilization means with a channel formed in the support member; an upper support rib; and an inner glide surface having substantially the same configuration as the outer wall of the slat. RIB 75. The Mark 2 Posisorter, Vanderlande maintains, does not have a glide surface that surrounds the slat, nor does it have enlarged radius corners, a channel at the bottom of the shoe, or an upper support rib. RIB 76. Vanderlande contends that the Mark 2 shoe also does not have an inner surface that is substantially the same configuration as the outer wall of the slat. *Id.* Accordingly, Vanderlande argues, there is no infringement of claim 30. *Id.*

According to the Staff, this “means plus function” element is governed by 35 U.S.C. § 112, ¶ 6 and can be satisfied by the presence in the Mark 2 Posisorter of the glide surface structure found in the ‘510 patent specification or an equivalent structure that performs the claimed function. SIB 65. The Staff contends that the ‘510 patent describes a substantially continuous glide surface surrounding the slat, with contact between an engaging portion of the shoe and least one enlarged radius corner of the slat, preferably at diagonally opposite slat edges. *Id.* The preferred embodiment, according to the Staff, describes areas of contact between the shoe and slat at all four corners of the slat. *Id.* The Staff further contends that the contact

surfaces of the glide surface of that embodiment provide the bearings that permit the shoe to resist reaction forces and slide along the slat. Id.

The Staff points out that the Mark 2 Posisorter uses contact bearings to enable gliding, and the contact surfaces between the shoe and slat of the Mark 2 are roughly analogous functionally to the contact surfaces between the shoe and slat as shown in the '510 patent. SIB 66. However, the Staff argues, the structural design that creates the contact surfaces in the Mark 2 is substantially different from the structure described in the '510 patent. Id. The contact surfaces of the Mark 2 Posisorter are found on the sides of three protrusions from the inner surface of the shoe. Id. These protrusions require matching channels in the slat, according to the Staff, unlike the structure described in the '510 patent, in the which shoe contacts the slat on outward facing surfaces at the corners of the slat. Id.

The Staff also argues that the Mark 2 Posisorter does not use the corners of the slat to resist reaction forces in the manner described in the '510 patent. SIB 66. There is no contact at all between the upper surface of the slat and the inner surface of the shoe in the Mark 2 Posisorter, according to the Staff. Id. As a result of these substantial structural differences in the Mark 2 Posisorter shoe and slat combination, the Staff argues, the “means defining a glide surface” limitation is not met. Id.

As construed herein, the element in claim 30 consisting of “a glide portion including means defining a glide surface adapted to glide along one of said slats” combines all of the structural features of the preferred embodiment of the invention of the '510 patent that perform the function of “adapt[ing]” the shoe “to glide along

one of said slats.” These include (i) the configurational structures, such as the shoe’s inner surface being “substantially continuous,” having “substantially the same configuration” as the outer surface of the slat, “surrounding” the slat, and having an overall “parallelogram-shaped cross-section;” and (ii) the contact structures, such as the “bearing means” and the “lateral stabilizing means.” As this element of claim 30 is, by agreement of all parties, a “means plus function” element that invokes the provisions of 35 U.S.C. § 112, ¶ 6, it therefore encompasses structure that is the same as, or equivalent to, the foregoing structural features that perform the function of adapting a glide surface to glide along a slat.

As already determined herein in connection with other claims, the Mark 2 Posisorter diverter shoe has either the same or equivalent configurational features to the embodiment of the invention disclosed in the ‘510 patent.<sup>11</sup> It has also been determined in connection with other claims, however, that although the Mark 2 has an equivalent “lateral stabilizing means” structure to that shown in the preferred embodiment, it does not have the “bearing means” structure of the preferred embodiment or its structural equivalent. Therefore, it does not have the same or equivalent structure that performs the function of “adapt[ing]” the glide surface “to glide along one of said slats,” and does not meet this limitation of claim 30.

---

<sup>11</sup>Although dependent claim 3, which claims a right cylinder having “a parallelogram-shaped cross-section,” is not at issue, and no evidence has been taken as to whether the Mark 2 Posisorter has “a parallelogram-shaped cross-section” as does the embodiment of the invention disclosed in the ‘510 patent, it is presumed that the shape of the Mark 2 slat and shoe, which have been found to constitute a right cylinder, is structurally equivalent to the right cylinder embodied in the parallelogram-shaped cross section of the invention.

**e. “A diverting member joined to said support member . . .”**

According to Rapistan and the Staff, the diverter shoe of the Mark 2 Posisorter has “a diverting member joined to said support member” as required by claim 30 that are joined by integral molding. CIB 113; CRB 84; SIB 67. Vanderlande contends that the Mark 2 Posisorter does not meet this limitation because the claim requires a two-part shoe, not a one-part shoe. RIB 93; RRB 67-68.

All parties agree that in the Mark 2 Posisorter shoe, the support member and diverting member are joined as a single unit by integral molding. See Radcliffe Tr. 1007:24-1008:3; Hoet 1998:23-1999:1; FF 228. Accordingly, since an integral, one-piece shoe structure satisfies this claim element as well as a two-piece shoe structure, the Mark 2 Posisorter shoe satisfies this claim element.

**f. “At least one substantially vertical diverting surface on a lateral end thereof”**

The parties do not dispute that the diverter shoe of the Mark 2 Posisorter has “at least one substantially vertical diverting surface on a lateral end thereof” as required by claim 30. FF 229.

**g. “A plurality of contiguous, generally planar surfaces . . .”**

According to Rapistan, the diverter shoe of the Mark 2 Posisorter has “a plurality of contiguous, generally planar surfaces sloping downward from an upper extent of said diverting surface laterally inward and longitudinally forward or

rearward” as required by claim 30. CIB 113-115; CRB 85-86. According to Rapistan, the sloped leading corners of the Mark 2 shoe slope in generally the same direction as those of the embodiment of the invention disclosed in the ‘510 patent. CIB 113; CRB 86.

Vanderlande and the Staff contend that the Mark 2 Posisorter does not meet this limitation. RIB 94-96; RRB 68-71; SIB 67-68; SRB 23-24. According to Vanderlande and the Staff, the two sloped corners of the Mark 2 Posisorter identified by Rapistan as satisfying this claim term slope laterally outward, not laterally inward as claim 30 requires. RIB 94-95; RRB 68-70; SIB 68. Moreover, Vanderlande and the Staff contend, the two corner surfaces are not adjacent and do not share a common border with one another, and also the surface between them slopes forward, not inward as claim 30 requires. RIB 95; RRB 68; SIB 68. Vanderlande and the Staff further contend that Rapistan has presented no evidence that these slopes satisfy the claim element under the doctrine of equivalents, if not literally. RIB 95-96; RRB 70-71; SRB 23-24.

Since the Mark 2 Posisorter shoe is a “bi-directional” member in that it can push a package laterally either way across a slat, the relevant construction of the claim term “laterally inward,” as set forth earlier herein, is toward the axis in between the vertical diverting surfaces; i.e., toward the middle of the shoe. As for the particular surfaces on the Mark 2 shoe that Rapistan contends satisfy the claim, Rapistan focuses on two slopes on either side of the shoe that, according to Rapistan, correspond to sloping surfaces 82c and 82j of the depiction of the preferred

embodiment of the invention shown in Figure 4 of the '510 patent. See CX-1 ('510 patent, Fig. 4).

Rapistan's expert, Radcliffe, testified that the Mark 2 shoe has three contiguous generally planar surfaces consisting of two lateral sloping surfaces and one forward sloping surface that, like the embodiment described in the '510 patent, slope downward from an upper extent of the diverting surface laterally inward and longitudinally forward toward the direction of flow of the conveyor. Radcliffe Tr. 1008:4-1009:7; CDX-9 slides 11 and 12; CDX-34 slides 11 and 12. According to Radcliffe, the two lateral surfaces on either side of and contiguous to the forward surface have the claimed laterally inward and longitudinally forward slope corresponding to surfaces 82c and 82j of the embodiment shown in the '510 patent. Radcliffe Tr. 1008:11-19; CDX slide 11; CDX-34 slide 11; FF 230. A comparison of the comparable surfaces on the two shoes is shown in CDX-9, slide 11 (corresponding to CDX-34, slide 11) as follows:

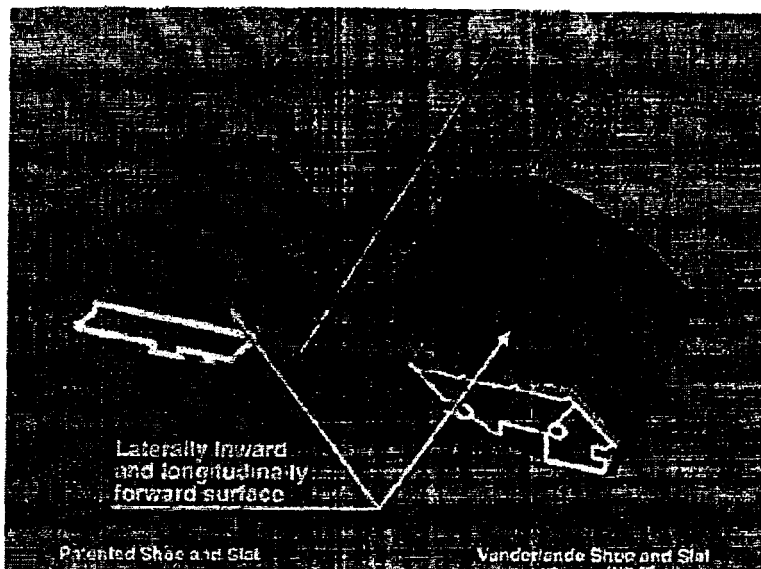

CDX-9, slide 11; CDX-34, slide 11.

Vanderlande and the Staff argue that this surface of the Mark 2 shoe faces laterally outward, not inward. In an attempt to prove that point, Vanderlande's expert, Hoet, prepared a series of demonstrative exhibits of both a Rapistan RS 200 shoe and a Vanderlande Mark 2 Posisorter shoe oriented in the same direction of conveyor flow and immersed in liquid (blackened water in the case of the Rapistan RS 200 shoe, milk in the case of the Mark 2 Posisorter shoe) in order to show the directions in which the liquid retreated from the slopes in question as each shoe emerges from the liquid. See Hoet Tr. 1866:24-1867:12; RDX-61-1 through RDX-61-8; RDX-62-1 through RDX-62-13; **FF 231**<sup>12</sup> As each shoe emerged, the boundary between the shoe's surface and the liquid formed a line that represents the slope of the surface at that line. Successive photographs were taken of that boundary as each shoe emerged from the liquid. See, e.g., RDX-61-4 (Rapistan RS 200 shoe); RDX-62-3 (Vanderlande Mark 2 Posisorter shoe); **FF 233**. Successive lines showing the boundary of the shoe and the liquid as each shoe emerged were then traced from the photographs onto topographic views of each shoe, and, at trial, Rapistan's counsel drew circles denoted "A" and "B" around the portions of the two topographic views that corresponded to the slopes in question. See Hoet Tr. 2055:1-2058:15; CDX-42A; CDX-42B; **FF 234**. Those exhibits are as follows:

---

<sup>12</sup>In order to more easily visualize the directionality of these sloping surfaces, Hoet referred to a physical Rapistan RS200 shoe as an exemplar of the preferred embodiment of the '510 patent because he recognized it to be a commercialization of that embodiment. See Hoet Tr. 2054:11-21; **FF 232**.

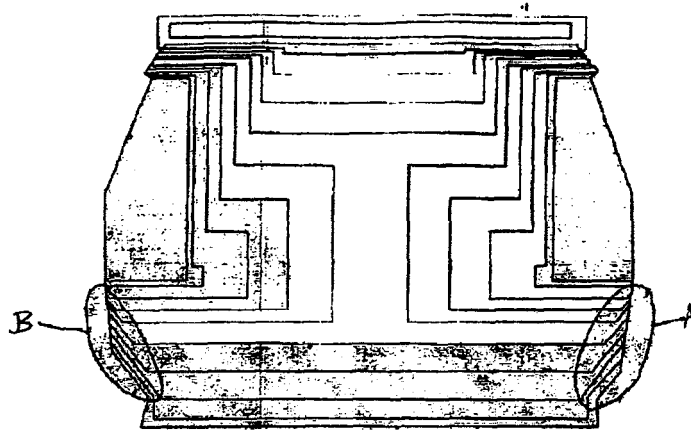

**Topographic View of RS 200 Shoe**

CDX-42A; and

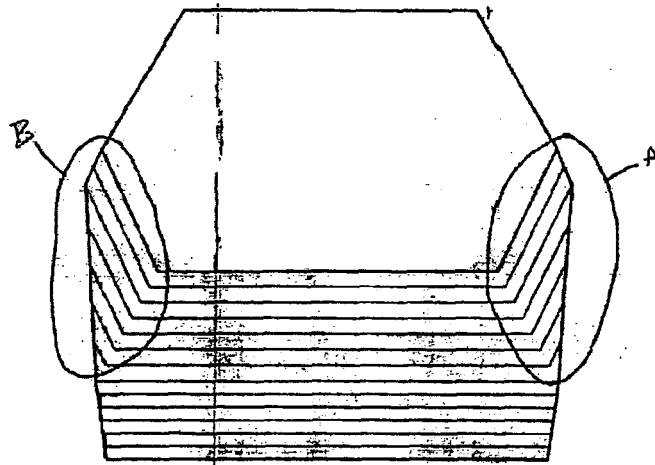

**Topographic View of Mark 2 Posisorter Shoe**

CDX-42B.

As is evident from these two topographic views, the lines representing the slopes of the RS200 and Mark 2 shoe surfaces marked "A" are both angled laterally



---

inward in the same direction toward the center of the shoe (i.e., from the upper right to the lower left), and the lines representing the slopes of the two shoe surfaces marked "B" are also both angled laterally inward in the same direction toward the center of the shoe (i.e., from the upper left to the lower right). CDX-42A; CDX-42B; **FF 235**. Thus, contrary to the assertions of Vanderlande and the Staff, the directions of the slopes of these two lateral surfaces of the Mark 2 shoe are the same as the directions of the slopes of the two corresponding lateral surfaces of the RS 200 shoe, not opposite.

Since the lines representing the slopes of the two lateral surfaces of the Mark 2 shoe are oriented the same way as those of the RS200 when the directions of conveyor flow are the same, and since the RS200, as the exemplar of the preferred embodiment of the '510 patent, is necessarily covered by the "laterally inward" element of claim 30, it follows, therefore, that the Mark 2 shoe is also covered by this element. As for the forward-sloping surface contiguous to and in between the two lateral slopes of the Mark 2 shoe, it too is oriented the same way as corresponding forward surfaces 82d and 82k of the embodiment of the '510 patent, as represented identically in the RS200 shoe, and therefore is covered by this element as well. If that were not the case, then the preferred embodiment of the '510 patent would not be covered by that element of the claim, and "[a] claim construction that excludes from its scope a preferred embodiment 'is rarely, if ever, correct and would require highly persuasive evidentiary support.'" Bowers v. Baystate Technologies, Inc., \_\_

F.3d \_\_, 2002 WL 1917337 at \*7 (Fed.Cir. 2002), quoting from Vitronics Corp. v. Conceptronic, Inc., 90 F.3d 1576, 1583 (Fed.Cir.1996).<sup>13</sup>

The fact that the two lateral slopes of the Mark 2 shoe are not contiguous to one another, as Vanderlande and the Staff also contend, is irrelevant because they are both contiguous to the forward-sloping surface in between them that is also covered by the claim, as Radcliffe pointed out and as further explained above.<sup>14</sup> Accordingly, the Mark 2 Posisorter literally satisfies the element of claim 30 requiring “a plurality of contiguous, generally planar surfaces sloping downward from an upper extent of said diverting surface laterally inward and longitudinally forward or rearward.”

---

<sup>13</sup>Although Vanderlande and the Staff maintain that the intermediate surface of the Mark 2 shoe is not sloped inward and therefore does not satisfy the claim element, it is noted that this surface is level in the inward direction, just like the corresponding slope of surfaces 82d and 82k on the embodiment of the invention of the ‘510 patent, as exemplified in the commercialized RS200 shoe. See CX-1 (‘510 patent, Fig. 4); compare CPX-4 with CPX-28; FF 236. Since a level surface is not sloped “outwardly” and this surface of the preferred embodiment satisfies the claim term, it follows that the same-sloped corresponding surface of the Mark 2 shoe satisfies the claim term as well.

<sup>14</sup>In support of its position on this point, Rapistan has referred to a recent decision in Honeywell, Inc. v. Victor Co., 298 F.3d 1317 (Fed.Cir. 2002) (“Honeywell”), in which the Federal Circuit probed the meaning of the word “contiguous” in instances where two things are “near” one another but do not touch. See Honeywell, 298 F.3d at 1324-25. In Honeywell, the Court analyzed this question in the context of the contiguity of a slice of bread to a slice of bologna in a sandwich when there is an intervening piece of cheese, and determined that the two are not contiguous to one another when the cheese is American whereas they may be if the cheese is Swiss, depending upon the content, if any, of the holes in the Swiss cheese. Id. Rapistan citation of Honeywell is not persuasive. In the instant investigation, the “bread” (here, one lateral slope) is clearly contiguous to the “cheese” (irrespective of its type, and here, the intermediate forward slope), which in turn is contiguous to the “bologna” (here, the other lateral slope). Honeywell, therefore, is inapplicable; a more appropriate food analogy in this case would be to the “contiguous” slices of a pizza.

**h. Conclusion as to infringement of '510 patent  
claim 30**

For the foregoing reasons, the Vanderlande Mark 2 Posisorter system does not infringe claim 30 of the '510 patent.

**11. Do Respondents' Mark 2 Posisorter Systems infringe claim 33 of the '510 patent?**

In order to infringe dependent claim 33 of the '510 patent, the diverter shoe of an accused conveying system must infringe independent claim 30 and, in addition, the support portion must be "molded of a polymeric material." CX-1 ('510 patent, col. 8:38-40). It has already been determined in connection with claims 20 and 27 that the diverter shoes of the Vanderlande Mark 2 Posisorter system are made of a polymeric material. However, since the Vanderlande Mark 2 Posisorter system does not infringe claim 30, it therefore does not infringe claim 33.

**12. Do Respondents' Mark 2 Posisorter Systems infringe claim 35 of the '510 patent?**

In order to infringe claim 35 of the '510 patent, the diverter shoe of an accused conveying system must infringe claims 30 and 33 and, in addition, the diverter shoe's glide portion must be "defined by a multiplicity of interconnected wall segments having substantially the same thickness." CX-1 ('510 patent, col. 8:43-45). As has already been determined in connection with claims 22 and 29, the language of this claim is not disputed, nor is it disputed that the Mark 2 Posisorter satisfies this limitation. It has also been determined already that the Mark 2 Posisorter satisfies the limitation of claim 33. However, since the Vanderlande Mark

2 Posisorter system does not infringe claim 30, it therefore does not infringe claim 35.

**13. Do Respondents' Mark 2 Posisorter Systems infringe claim 42 of the '510 patent?**

Independent claim 42 recites a combination of elements that appear in, and have already been construed in connection with, earlier claims. Accordingly, it is unnecessary to recount the positions of the parties on each element in stating the outcome as to each element.

**a. Undisputed Claim Elements**

The parties do not dispute that the Mark 2 Posisorter system has, as required by claim 42, "a diverter shoe for use in a conveyor system having a longitudinally moving conveying surface defined by the uppermost ones of a plurality of slats connected in spaced relation with each other in an endless web." FF 237.

**b. "Track means"**

As already determined in connection with claims 1, 13, 23 and 30, the Mark 2 Posisorter has the element also required by claim 42 of a "track means extending below said uppermost ones of said slats for engaging and imparting a lateral force to displace selected ones of said diverter shoes laterally with respect to said conveying surface."

**c. "A support member"**

As already determined in connection with claims 1, 13, 23 and 30, the diverter shoe of the Mark 2 Posisorter has the element also required by claim 42 consisting of "a support member."

**d. "A glide portion ..."**

As already determined in connection with claim 30, the "support member" of the Mark 2 Posisorter shoe does not have the element also required by claim 42 consisting of a "a glide portion including means defining a glide surface adapted to glide along one of said slats."

**e. "A diverting portion joined to said support portion ..."**

As already determined in connection with claim 30, the Mark 2 Posisorter has the element also required by claim 42 consisting of a "a diverting portion joined to said support portion."

**f. "At least one substantially vertical diverting surface on a lateral end thereof"**

As already determined in connection with claim 30, the diverting portion of the Mark 2 Posisorter shoe has "at least one substantially vertical diverting surface on a lateral end thereof" as also required by claim 42.

- g. “A multiplicity of interconnected wall segments  
...”**

As already determined in connection with claims 22, 29 and 35, the support member of the Mark 2 Posisorter shoe “is defined by a multiplicity of interconnected wall segments having substantially the same thickness.”

- h. Conclusion as to infringement of ‘510 patent  
claim 42**

For the foregoing reasons, the Vanderlande Mark 2 Posisorter system does not infringe claim 42 of the ‘510 patent.

- 14. Do Respondents’ Mark 2 Posisorter Systems infringe  
claim 43 of the ‘510 patent?**

In order to infringe dependent claim 43 of the ‘510 patent, the diverter shoe of an accused conveying system must infringe independent claim 42 and, in addition, the glide portion of the diverter shoe must be “molded of a polymeric material.” CX-1 (‘510 patent, col. 9:15-16). It has already been determined in connection with claims 20, 27 and 33 that the diverter shoes of the Vanderlande Mark 2 Posisorter system are made of a polymeric material. However, since the Vanderlande Mark 2 Posisorter system does not infringe claim 42, it therefore does not infringe claim 43.

- 15. Do Respondents’ Mark 2 Posisorter Systems infringe  
claim 45 of the ‘510 patent?**

In order to infringe claim 45 of the ‘510 patent, the diverter shoe of an accused conveying system must infringe claim 42 and, in addition, the diverter shoe’s support member must “include[ ] a follower portion adapted to be engaged by said

track means and a base portion defined by said glide portion for mounting of said follower portion, said base portion defined by a plurality of said wall segments arranged in a honey-comb manner.” CX-1 (‘510 patent, cols. 9:19-10:2). The language of this claim is not disputed, nor is it disputed that the Mark 2 Posisorter satisfies this limitation. See Radcliffe Tr. 1028:4-13; FF 238. However, since the diverter shoe of the Mark 2 Posisorter system does not infringe claim 42, it therefore does not infringe claim 45.

### **C. Contributory and Induced Infringement**

#### **1. Relevant Law**

To establish a claim for induced infringement, a complainant must show that a respondent has actively induced a person to make, use, or sell a product or use a method that falls within the scope of the claims of the patent at issue. 35 U.S.C. § 271(b). The required elements of a claim of induced infringement are: “(1) an act of direct infringement; (2) the accused infringer actively induced a third party to infringe the patent; and (3) the accused infringer knew or should have known that his actions would induce infringement.” Certain Flash Memory Circuits and Products Containing Same, Inv. No. 337-TA-382, U.S.I.T.C. Pub. 3046, Commission Opinion on the Issues Under Review and on Remedy, the Public Interest, and Bonding, at 16, 1997 WL 817778 (U.S.I.T.C., July 1997) (“Flash Memory, Commission Opinion”).

Under 35 U.S.C. § 271(c), a seller of a component of an infringing product can be held liable for contributory infringement if: “(1) there has been an act of direct infringement by a third party; (2) the accused contributory infringer knows that

the combination for which its component was made was both patented and infringing; and (3) there are no substantial non-infringing uses for the component part, *i.e.*, the component is not a 'staple article' of commerce." Flash Memory, Commission Opinion at 9-10.

**2. Have Respondents induced infringement or engaged in contributory infringement of the '510 patent?**

According to Rapistan, Vanderlande's activities in importing infringing shoes and slats and assembling them in Kentucky (and at other locations in the United States) constitute both contributory and induced infringement of the asserted claims of the '510 patent. CIB 120-121; CRB 86-88. The Mark 2 Posisorter directly infringes the asserted claims of the '510 patent, according to Rapistan. CIB 121; CRB 87. Further, Rapistan argues, Vanderlande knew that the shoe and slat were used in an infringing manner because Vanderlande obtained and reviewed the '510 patent and was put on notice by Rapistan that the Mark 2 Posisorter would infringe that patent if sold and used by customers in the United States. CIB 121; CRB 87. The shoes and slats of the Mark 2 Posisorter, according to Rapistan, are especially made by Vanderlande and have been imported by Vanderlande for use in building an infringing conveyor system or as replacement parts for that infringing system, and therefore are not "staple articles or commodities of commerce suitable for substantial noninfringing use." CIB 122-23; CRB 87. In addition, Rapistan contends, Vanderlande knowingly shipped these products into the United States and instructed its customers on how to make and use an infringing conveyor system, thereby inducing infringement. CIB 123; CRB 87-88.



Vanderlande contends that its activities in connection with sale and importation of the Mark 2 Posisorter to the United States constitute neither contributory nor induced infringement. RIB 96-99; RRB 72-75. First, Vanderlande contends, there is no direct infringement of any asserted claim of the '510 patent. RIB 99; RRB 74. Further, Vanderlande contends that there is no evidence that Vanderlande has actively, knowingly and intentionally aided and abetted infringing activity by another. RIB 99; RRB 73. Vanderlande further contends that there is no evidence that it knew that the accused product is both patented and infringing. RIB 99.

The Staff contends that the Mark 2 Posisorter does not infringe any of the claims of the '510 patent, and therefore that Vanderlande does not engage in contributory or induced infringement. SIB 71; SRB 26. However, the Staff argues, if the Mark 2 Posisorter is found to infringe any or all claims of the '510 patent, then Vanderlande does engage in contributory and induced infringement. SIB 71-72; SRB 24-26. According to the Staff, the Mark 2 Posisorter shoes and slats are a material part of the invention, are especially made for use in an infringement of the '510 patent (assuming that the Mark 2 is found to infringe), and are not staple articles of commerce suitable for substantial noninfringing use. SIB 71. The Staff further maintains that Vanderlande also had the requisite knowledge, prior to the importation of the Mark 2 components, of the '510 patent. Id.

The Vanderlande Mark 2 Posisorter has been found herein to infringe claims 1 and 4 of the '510 patent. Accordingly, the first criterion of both induced and

---

contributory infringement, direct infringement of the '510 patent, has been established.

In connection with Vanderlande's knowledge of infringement, it is undisputed that Vanderlande has known of the '510 patent since November 1992. CX-218; van den Goor Tr. 1735:21-1736:21; FF 239. Vanderlande was informed by Rapistan's counsel, the Van Dyke firm, by letter dated June 19, 1998, prior to Vanderlande's submission of its bid to UPS, that the Mark 2 Posisorter "would constitute an infringement of at least United States Patent 5,127,510 if made, used, sold or offered for sale or imported to the United States of America." RX-426; FF 240. Vanderlande's president, Rein van der Lande, postponed responding to this letter because of the ongoing bid process with UPS. Van der Lande Tr. 1614:12-18, 1642:12-1643:3; FF 241. It was not until after the UPS bid was awarded to Vanderlande in August 1998 that Rein van der Lande responded to Rapistan asserting that the Mark 2 Posisorter did not infringe the '510 patent. Van der Lande Tr. 1660:1-14; FF 242. [

] Bobilin Tr. 1295:4-11; Martin Tr. 1905:9-15; FF 243. Thus, Vanderlande knew or should have known at the time it submitted its bid to UPS that the Mark 2 Posisorter system, if imported into the United States and sold to UPS, would infringe the '510 patent, and knew or should have known that doing so would induce UPS to infringe that patent.

Vanderlande argues that because it received an opinion of counsel in support of its non-infringement position, and because Rapistan delayed for so many years in

---

suing Vanderlande for infringement, that Vanderlande therefore did not have the requisite intent to engage in induced infringement under 35 U.S.C. § 271(b). RRB 73-74. Rapistan concedes that it must establish “actual intent to cause the acts which constitute the infringement [which] is a necessary prerequisite to finding active inducement.” CIB 119, citing Hewlett-Packard Co. v. Bausch & Lomb, Inc., 909 F.2d 1464, 1469 (Fed.Cir. 1990). However, Rapistan argues, the opinion of counsel that Vanderlande received and referred to in its January 1999 response to Rapistan is not in the record, and absent that evidence, and in the presence of notice from Rapistan, Vanderlande’s intent to induce infringement is established. CIB 120, citing Water Technologies Corp. v. Calco, Ltd., 850 F.2d 660, 668-69 (Fed.Cir.), cert. denied, 488 U.S. 968 (1988) (upholding finding of induced infringement under Section 271(b) despite evidence of subjective belief in non-infringement, in the absence of obtaining non-infringement opinion of counsel).

“Active inducement requires a finding of actual intent to cause the acts which cause the infringement.” FMT Corp., Inc. v. Nissei ASB Co., 1991 WL 541113 at \*8 (N.D.Ga.,1991) (“FMT”). “[C]onduct including licensing, repair and maintenance, instruction and advertising, design and assisting in manufacture have been sufficient to hold one liable for [inducing] infringement under § 271(b).” Symbol Technologies, Inc. v. Metrologic Instruments, Inc., 771 F.Supp. 1390, 1405 (D.N.J. 1991) (emphasis added) (“Symbol Technologies”). As discussed later herein in connection with Vanderlande’s estoppel defense, Vanderlande’s active conduct in the design and assembly of the UPS Hub 2000 facility in Louisville, Kentucky is well-established

in the record. As for Vanderlande's opinion of counsel, to the extent that it is of record here, such evidence has been found by at least one district court to have no relevance in determining whether there is induced infringement. See Symbol Technologies, supra, 771 F.Supp. at 1405. Accordingly, the elements of induced infringement are established.

Concerning contributory infringement, the Mark 2 Posisorter shoe and slat are the only components that constitute the subject matter of the '510 patent, and therefore their use and sale in the United States cannot have any use other than an infringing use. See CX-1 ('510 patent); FF 244. Thus, all of the elements of contributory infringement are established.

Accordingly, Vanderlande's importation and sale of the Mark 2 Posisorter system in the United States constitutes contributory infringement and induced infringement in violation of 35 U.S.C. § 271(b) and (c).

## **VI. Domestic Industry**

In a patent-based complaint, a violation of Section 337 can be found "only if an industry in the United States, relating to the articles protected by the patent . . . concerned, exists or is in the process of being established." 19 U.S.C. § 1337(a)(2). This "domestic industry requirement" has an "economic" prong and a "technical" prong.

### **A. Economic Prong**

#### **1. Relevant Law**

---

Section 337(a)(3) sets forth the following economic criteria for determining the existence of a domestic industry in investigations based on patent infringement:

an industry in the United States shall be considered to exist if there is in the United States, with respect to the articles protected by the . . . patent . . . concerned –

- (A) significant investment in plant and equipment;
- (B) significant employment of labor or capital; or
- (C) substantial investment in its exploitation, including engineering, research and development, or licensing.

19 U.S.C. § 1337(a)(3). The existence of a domestic industry is measured at the time the complaint is filed. Bally/Midway Mfg. Co. v. U.S. Int'l Trade Comm., 714 F.2d 1117, 1122 (Fed.Cir. 1983).

**2. Is there a domestic industry that meets the economic criteria of Section 337?**

Inasmuch as Rapistan has satisfied the technical prong of the domestic industry analysis as set forth below, Rapistan has also, by stipulation of the parties, satisfied the economic prong of the domestic industry requirement. FF 106 (First Joint Stipulation No. 121).

**B. Technical Prong**

**1. Relevant Law**

In addition to meeting the economic criteria of the domestic industry requirement, a complainant in a patent-based Section 337 investigation must also demonstrate that it is practicing or exploiting the patents at issue. See 19 U.S.C. § 1337(a)(2) and (3); also see Certain Microsphere Adhesives, Process for Making

Same, and Products Containing Same, Including Self-Stick Repositionable Notes, Inv. No. 337-TA-366, Commission Opinion at 8, 1996 WL 1056095 (U.S.I.T.C., January 16, 1996) (“Microsphere Adhesives”), aff’d sub nom. Minnesota Mining & Manufacturing Co. v. U.S. Int’l. Trade Comm., 91 F.3d 171 (Fed.Cir. 1996) (Table); Certain Plastic Encapsulated Integrated Circuits, Components Thereof, and Products Containing Same, Inv. No. 337-TA-315, U.S.I.T.C. Pub. No. 2574, Commission Opinion at 16, 1992 WL 813959 (U.S.I.T.C., February 18, 1992). In order to find the existence of a domestic industry exploiting a patent at issue, it is sufficient to show that the domestic industry practices any claim of that patent, not necessarily an asserted claim of that patent. Microsphere Adhesives, Commission Opinion at 7-16. Fulfillment of this so-called “technical prong” of the domestic industry requirement is not determined by a rigid formula, but rather by the articles of commerce and the realities of the marketplace. Certain Diltiazem Hydrochloride and Diltiazem Preparations, Inv. No. 337-TA-349, U.S.I.T.C. Pub. No. 2902, Initial Determination at 138, 1995 WL 945191 (U.S.I.T.C., February 1, 1995) (unreviewed in relevant part); Certain Double-Sided Floppy Disk Drives and Components Thereof, Inv. No. 337-TA-215, 227 U.S.P.Q. 982, 989 (Commission Opinion 1985).

The test for claim coverage for the purposes of the technical prong of the domestic industry requirement is the same as that for infringement. Certain Doxorubicin and Preparations Containing Same, Inv. No. 337-TA-300, Initial Determination at 109, 1990 WL 710463 (U.S.I.T.C., May 21, 1990), aff’d, Views of the Commission at 22 (October 31, 1990). “First, the claims of the patent are

construed. Second, the complainant's article or process is examined to determine whether it falls within the scope of the claims." Id. As with infringement, the first step of claim construction is a question of law, whereas the second step of comparing the article to the claims is a factual determination. Markman, supra, 52 F.3d at 976. To prevail, the patentee must establish by a preponderance of the evidence that the domestic product practices one or more claims of the patent either literally or under the doctrine of equivalents. See Bayer, supra, 212 F.3d at 1247.

**2. Does the domestic industry practice the '510 patent?**

Rapistan contends that its RS200 conveyor system slat and shoe fulfill the technical prong of the domestic industry requirement because they are virtually identical to the '510 patent drawings of the preferred embodiment, as Vanderlande's expert admitted. CIB 175-76. Only minor changes have been made to the slat and shoe, according to Rapistan. Id. Rapistan maintains that the RS200 practices at least claims 1 and 23 of the '510 patent. CIB 175; CRB 163.

Vanderlande argues that Rapistan has failed to meet its burden of proving that the alleged domestic industry practices at least one claim of the '510 patent. RIB 156. According to Vanderlande, the testimony of Rapistan's expert, Radcliffe, on this subject was conclusory and without foundation, and that he admitted at trial that he had never visited a customer site to inspect a functioning commercial RS200 product. RIB 156; RRB 113. Vanderlande argues that Radcliffe also accepted that there are numerous differences between the product described in the '510 patent and what he understands Rapistan manufactures as the RS200. RRB 113. For instance,

Vanderlande maintains that there is now no T-shaped projection on the bottom of the RS200 slat; that the enlarged radius corners on the slat are not present, but instead flattened out; that the center support rib does not contact the top of the slat; and that the slat has internal supports. RIB 156; RRB 113. According to Vanderlande, the presence of internal supports means that the RS200 slat is no longer a “right cylinder” as claim 1 requires, the absence of a “T”-shaped projection means that there is no “lateral stabilizing means” as required by claim 23, and the absence of enlarged radius corners means that there is no “bearing means” of claim 13 and “means . . . adapted to glide” of claims 30 and 42. RRB 114. Vanderlande also contends that Rapistan failed to adduce evidence regarding the form of the diverter switch required by the ‘510 patent’s “track means” element, and if that element requires a horizontal switch as Rapistan advocates, then the RS200 product is not covered by that element of the ‘510 patent claims. RIB 156-57; RRB 115.

According to the Staff, the evidence shows that Rapistan’s RS200 sortation system, which is manufactured in the United States, is covered by at least claim 1 of the ‘510 patent based a proper claim construction. SIB 96-98. The RS200 closely resembles the preferred embodiment described in the ‘510 patent, with only minor variations, according to the Staff. SIB 96-97. Thus, the Staff contends, a claim construction that excludes the RS200 from coverage by the ‘510 patent would have to be viewed with suspicion. SIB 97.

[



] Brouckman Tr. 221:16-23; Van Alten Tr. 2184:22-2185:7;

**FF 245.** The original versions of the RS200 slat and shoe are exemplified by physical exhibits CPX-31 (left-handed diverter shoe) and CPX-32 (slat). Van Alten Tr. 2184:22-2185:7; CPX-31; CPX-32; **FF 246.** The current versions of the RS200 slat and shoe that are manufactured in Michigan and marketed by Rapistan are exemplified by physical exhibits CPX-21 (slat) and CPX-22 (bi-directional diverter shoe). Woltjer Tr. 316:5-15, 317:16-20; CPX-21; CPX-22; **FF 247.**

Rapistan's expert, Radcliffe, testified that the current version of the RS200 made by Rapistan practices claim 1 of the '510 patent. Radcliffe Tr. 859:4-860:24; CPX-21; CPX-22; **FF 248.** In particular, Radcliffe testified that the RS200 is a conveying system having a longitudinally moving conveying surface defined by the uppermost ones of a plurality of slats. Id. The slats, according to Radcliffe, are connected at opposite ends in spaced relation to each other to a pair of endless chains. Id. To space the slats on the conveyor, Radcliffe stated, there is a plurality of diverter shoes, each of which is movably mounted on the slats. Id. Radcliffe also stated that the RS200 has track means for engaging the diverter shoes for imparting a lateral force to move the diverter shoes laterally to displace product. Id. Each of the slats in the RS200 is defined by a wall that is formed as a right cylinder and includes an outer surface having an upper planar portion defining the conveying surface. Id. Each of the diverter shoes, according to Radcliffe, has a support portion that includes a substantially continuous glide surface on the interior surface of the support portion of the diverter shoe which surrounds the wall. Id.

Radcliffe also testified that the current version of the RS200 practices claim 23 of the '510 patent as well. Radcliffe Tr. 953:3-954:12; CPX-21; CPX-22; FF 249. In particular, Radcliffe testified that the RS200 shoe and slat are part of a conveying system having a longitudinally moving conveying surface defined by the uppermost ones of a plurality of slats connected in spaced relation with each other in an endless web. Id. The current RS200, according to Radcliffe, has a plurality of diverter shoes each movably mounted on one of the slats for lateral movement with respect to the conveying surface, and there is a track means for engaging these diverter shoes to impart a lateral force to move the diverter shoes laterally to displace product positioned on the conveying surface. Id. In addition, Radcliffe testified, the RS200 has slats defined by a wall having generally planar upper and lower wall portions, and each of these portions is joined by sidewall portions defining four joining edges between each of the wall portions. Id. Radcliffe also stated that each of the diverter shoes includes a glide surface, the inner surface of the shoe surrounding the wall. Id. There is also a means defining a lateral stabilizing means in the lower wall portion of the slat, according to Radcliffe, and an engaging portion constituting a channel in the diverter shoe where the lateral stabilizing means resists vertical-axis reaction-force-couples. Id.

There have been some changes made to the RS200 slat and shoe since it was originally introduced. Woltjer Tr. 317:21-318:3; Radcliffe Tr. 733:17-734:19; CPX-21; CPX-22; CPX-31; CPX-32; FF 250. In 1993, an internal web was added to the interior of the slat to absorb noise and the cutouts on either side of the lateral

stabilizer projection that gave it a “T”-shape were eliminated. Woltjer Tr. 318:7-319:3; Radcliffe Tr. 734:15-19, 1241:7-11 and 1241:25-1242:3; **FF 251**. In 1995, the enlarged radius corners at the front and rear of the upper conveying surface of the slat were flattened out. Woltjer Tr. 319:4-15; Radcliffe 1241:12-18; **FF 252**. Also, the center support rib in the middle of the upper glide surface of the shoe was reduced so that its contact with the upper conveying surface of the slat was eliminated. Woltjer Tr. 319:16-11; Radcliffe 734:8-11 and 1241:19-24; **FF 253**.

None of the foregoing alterations to the original RS200 change the foregoing domestic industry analysis as the claims of the ‘510 patent are construed in this Initial Determination. As with the Mark 2 Posisorter, the presence of an internal web in the current version of the RS200 does not alter the fact that the outer surface of the wall of the slat is a “right cylinder” as construed herein. As with the Mark 2 Posisorter, the rectangular shape of the current RS200’s lateral stabilizer instead of the original “T”-shape is structurally equivalent to the original design, and therefore literally covered by the “lateral stabilizing means” element of claim 23. The fact that the enlarged radius corners of the upper conveying surface of the original RS200 were flattened out in the current version makes no difference to either claim 1 or claim 23, which do not include the “bearing means” element. Finally, the reduced center support rib of the upper glide surface of the current version of the RS200 diverter shoe has nothing to do with the “glide surface” element of either claim as construed herein.

Vanderlande's argument that the RS200's use of either a vertical or magnetic diverter switch in its track system excludes the RS200 from the '510 patent claims also fails, because as construed in this Initial Determination, the diverter switch can be horizontal, vertical, electrical, or pneumatic, and a "magnetic" switch is presumably electrically controlled.

In short, with only a few insubstantial differences, the current version of the Rapistan RS200 sortation system slat and shoe is identical to the preferred embodiment of the invention of the '510 patent and practices claims 1 and 23 of that patent. The technical prong of the domestic industry requirement of Section 337 is, therefore, literally satisfied.

## **VII. Invalidity**

### **A. Relevant Law**

A patent is presumed valid. 35 U.S.C. § 282; Richardson-Vicks Inc. v. The Upjohn Co., 122 F.3d 1476, 1480 (Fed.Cir. 1997) ("Richardson-Vicks"). The party challenging a patent's validity has the burden of overcoming this presumption by clear and convincing evidence. Richardson-Vicks, supra; Uniroyal, Inc. v. Rudkin-Wiley Corp., 837 F.2d 1044 (Fed.Cir.), cert. denied, 488 U.S. 825 (1988).

Since the claims of a patent measure the invention at issue, the claims must be interpreted and given the same meaning for purposes of both validity and infringement analyses. As with an infringement analysis, an analysis of invalidity involves two steps: the claim scope is first determined, and then the properly construed claim is compared with the prior art to determine whether the claimed

invention is anticipated and/or rendered obvious. Amazon.com, Inc. v. Barnesandnoble.com, Inc., 239 F.3d 1343, 1351 (Fed.Cir. 2001).

A determination that an independent claim is invalid does not automatically mean that a dependent claim that depends from it is also invalid. “Each claim carries an independent presumption of validity, 35 U.S.C. § 282, and stands or falls independent of the other claims.” Continental Can Co., USA v. Monsanto Co., 948 F.2d 1264, 1266-67 (Fed.Cir. 1991) (“Continental Can”); also see 35 U.S.C. § 282.<sup>15</sup>

**1. Anticipation -- 35 U.S.C. §§ 102(a), (b) and (e)**

A patent may be found invalid as anticipated under 35 U.S.C. § 102(a) if “the invention was known or used by others in this country, or patented or described in a printed publication in this or a foreign country, before the invention thereof by the applicant for patent.” 35 U.S.C. § 102(a). Under 35 U.S.C. § 102(b), a patent is invalid as anticipated if “the invention was patented or described in a printed

---

<sup>15</sup>In Richardson-Vicks, supra, a Federal Circuit panel held that if the validity of a dependent claim is not argued separately from the independent claim from which it depends, its validity will stand or fall with the independent claim. See Richardson-Vicks, supra, 122 F.3d at 1480; rehearing denied, in banc suggestion declined. However, an earlier Federal Circuit panel ruled that the notion that failure to argue validity of dependent claim separately makes claim stand or fall with claim from which it depends “flies in the face of the presumption of validity” and, although relevant in prosecuting patent applications before PTO, has “no application in a district court proceeding to determine whether the claims of an issued patent are valid.” Shellcore, Inc. v. Durham Industries, Inc., 745 F.2d 621, 624-25 (Fed.Cir. 1984). In Shellcore, the Federal Circuit further held that “a party challenging the validity of a claim, absent a pretrial agreement or stipulation, must submit evidence supporting a conclusion of invalidity of each claim the challenger seeks to destroy.” Id. Hence, under Shellcore, and contrary to Richardson-Vicks, if an independent claim is ruled invalid and no separate argument is made concerning the validity or invalidity of a claim that depends from it, the presumption of validity of 35 U.S.C. § 282 operates to render the dependent claim valid. To date, the Federal Circuit has not cleared up this conflict by an en banc ruling.

---

publication in this or a foreign country . . . more than one year prior to the date of the application for patent in the United States.” 35 U.S.C. § 102(b). Under 35 U.S.C. § 102(e), a patent is invalid as anticipated if “the invention was described in a patent granted on an application for patent by another filed in the United States before the invention thereof by the applicant for patent.” 35 U.S.C. § 102(e). Anticipation is a question of fact. Texas Instruments, Inc. v. U.S. Int’l. Trade Comm., 988 F.2d 1165, 1177 (Fed.Cir. 1993).

Under the foregoing statutory provisions, a claim is anticipated and therefore invalid when “the four corners of a single, prior art document describe[s] every element of the claimed invention, either expressly or inherently, such that a person of ordinary skill in the art could practice the invention without undue experimentation.” Advanced Display Systems, Inc. v. Kent State University, 212 F.3d 1272, 1282 (Fed.Cir. 2000). To be considered anticipatory, the prior art reference must be enabling and describe the applicant’s claimed invention sufficiently to have placed it in possession of a person of ordinary skill in the field of the invention. Helifix Ltd. v. Blok-Lok, Ltd., 208 F.3d 1339, 1346 (Fed.Cir. 2000); In re Paulsen, 30 F.3d 1475, 1478 (Fed.Cir. 1994). However, the degree of enabling detail contained in the reference does not have to exceed that contained in the patent at issue. See In re Paulsen, supra, at 1481 n.9. Further, the disclosure in the prior art reference does not have to be express, but may anticipate by inherency where the inherency would be appreciated by one of ordinary skill in the art. Glaxo Inc. v. Novopharm Ltd., 52 F.3d 1043, 1047 (Fed.Cir.), cert. denied, 516 U.S. 988 (1995).

## 2. Derivation – 35 U.S.C. § 102(f)

A patent is valid unless, under 35 U.S.C. § 102(f), the inventor “did not himself invent the subject matter sought to be patented.” 35 U.S.C. § 102(f). A patent is invalid under 35 U.S.C. § 102(f) as derived from another if someone else conceived the invention earlier than the patentee and communicated that conception to the patentee. Price v. Symsek, 988 F.2d 1187, 1190 (Fed.Cir. 1993). The communication of the prior conception must be sufficient to enable a person of ordinary skill in the art, “without the exercise of any ingenuity and special skill on his part, to construct and put the improvement in successful operation.” Gambro Lundia AB v. Baxter Healthcare Corp., 110 F.3d 1573,1577 (Fed.Cir. 1997) (“Gambro”). Derivation under Section 102(f) is a question of fact. Price v. Symsek, supra.

## 3. Obviousness -- 35 U.S.C. § 103(a)

Under 35 U.S.C. § 103(a), a patent is valid unless “the differences between the subject matter sought to be patented and the prior art are such that the subject matter as a whole would have been obvious at the time the invention was made to a person having ordinary skill in the art to which said subject matter pertains.” 35 U.S.C. § 103(a). The ultimate question of obviousness is a question of law, but “it is well understood that there are factual issues underlying the ultimate obviousness decision.” Richardson-Vicks, supra, 122 F.3d at 1479; Wang Laboratories, Inc. v. Toshiba Corp., 993 F.2d 858, 863 (Fed.Cir. 1993).

Once claims have been properly construed, “[t]he second step in an obviousness inquiry is to determine whether the claimed invention would have been obvious as a legal matter, based on underlying factual inquiries including : (1) the scope and content of the prior art, (2) the level of ordinary skill in the art, (3) the differences between the claimed invention and the prior art; and (4) secondary considerations of non-obviousness” (also known as “objective evidence”). Smiths Industries Medical Systems, Inc. v. Vital Signs, Inc., 183 F.3d 1347, 1354 (Fed.Cir. 1999) (“Smiths Industries”), citing Graham v. John Deere Co., 383 U.S. 1, 17 (1966).

In this case, the parties have stipulated that one of ordinary skill in the art with respect to the ‘510 patent is a person having at least an associate’s degree in science and engineering, and from three to five years of experience in the field of equipment design, including experience in the design and operation of material handling equipment or conveyor sortation equipment, or a corresponding amount of practical experience. **FF 48** (First Joint Stipulation No. 48).

In order to prove obviousness, the patent challenger must demonstrate, by clear and convincing evidence, that “there is a reason, suggestion, or motivation in the prior art that would lead one of ordinary skill in the art to combine the references, and that would also suggest a reasonable likelihood of success.” Smiths Industries, supra, 183 F.3d at 1356; also see United States Surgical Corp. v. Ethicon, Inc., 103 F.3d 1554, 1564 (Fed.Cir. 1997), cert. denied, 522 U.S. 950 (1997); Certain Integrated Circuit Telecommunication Chips and Products Containing Same, Including Dialing Apparatus, Inv. No. 337-TA-337, Commission Opinion at 18



(August 3, 1993). When an obviousness determination relies on the combination of two or more references, “[t]he suggestion to combine may be found in explicit or implicit teachings within the references themselves, from the ordinary knowledge of those skilled in the art, or from the nature of the problem to be solved . . . the question is whether there is something in the prior art as a whole to suggest the desirability, and thus the obviousness, of making the combination.” WMS Gaming, Inc. v. International Game Technology, 184 F.3d 1339, 1355 (Fed.Cir. 1999) (“WMS Gaming”).

“Secondary considerations,” also referred to as “objective evidence of non-obviousness,” such as “commercial success, long felt but unsolved needs, failure of others, etc.” may be used to understand the origin of the subject matter at issue, and may be relevant as indicia of obviousness or non-obviousness. Graham v. John Deere Co., *supra*, 383 U.S. at 17-18. Secondary considerations may also include copying by others, prior art teaching away, and professional acclaim. See Perkin-Elmer Corp. v. Computervision Corp., 732 F.2d 888, 894 (Fed.Cir.), *cert. denied*, 469 U.S. 857 (1984); Avia Group Int’l, Inc. v. L.A. Gear California, 853 F.2d 1557, 1564 (Fed.Cir. 1988) (copying by others); In re Hedges, 783 F.2d 1038, 1041 (Fed.Cir. 1986) (prior art teaching away; invention contrary to accepted wisdom); Kloster Speedsteel AB v. Crucible Inc., 793 F.2d 1565 (Fed.Cir. 1986), *cert. denied*, 479 U.S. 1034 (1987) (wide acceptance and recognition of the invention).

Evidence of “objective indicia of non-obviousness,” also known as “secondary considerations,” must be considered in evaluating the obviousness of a

claimed invention, but the existence of such evidence does not control the obviousness determination. A court must consider all of the evidence under the Graham factors before reaching a decision on obviousness. Richardson-Vicks, supra, 122 F.3d at 1483-84. In order to accord objective evidence substantial weight, its proponent must establish a nexus between the evidence and the merits of the claimed invention, and a prima facie case is generally made out “when the patentee shows both that there is commercial success, and that the thing (product or method) that is commercially successful is the invention disclosed and claimed in the patent.” In re GPAC Inc., 57 F.3d 1573, 1580 (Fed.Cir. 1995); Demaco Corp. v. F. Von Langsdorff Licensing Ltd., 851 F.2d 1387, 1392 (Fed.Cir.), cert. denied, 488 U.S. 956 (1988) (“Demaco”); Certain Crystalline Cefadroxil Monohydrate, 15 U.S.P.Q.2d 1263, 1270 (U.S.I.T.C. 1990). Once the patentee has made a prima facie case of nexus, the burden shifts to the challenger to show that the commercial success was caused by “extraneous factors other than the patented invention, such as advertising, superior workmanship, etc.” Id. at 1393.

#### 4. Indefinite Written Description -- 35 U.S.C. § 112, ¶ 1

Section 112, ¶ 1 of Title 35 requires that “[t]he specification shall contain a written description of the invention.” Although this requirement does not mean that the applicant must describe exactly the subject matter claimed, it is satisfied if the specification “clearly allow[s] persons of ordinary skill in the art to recognize that he or she invented what is claimed.” In re Hayes Microcomputer Products, Inc. Patent Litigation, 982 F.2d 1527, 1533 (Fed.Cir. 1992) (“Hayes”). The specification must

demonstrate that the inventor was in possession of the invention at the time of filing of the application. See In re Alton, 76 F.3d 1168, 1172 (Fed.Cir. 1996) (“The adequate written description requirement . . . serves ‘to ensure that the inventor had possession, as of the filing date of the application relied on, of the specific subject matter later claimed by him; how the specification accomplishes this is not material.’”). Whether the written description requirement has been met is a question of fact. Wang Laboratories, Inc. v. Toshiba Corporation, 993 F.2d 858, 865 (Fed.Cir. 1993).

#### 5. Indefinite Claims – 35 U.S.C. § 112, ¶ 2

Claims must “. . . particularly point[ ] out and distinctly claim[ ] the subject matter which the applicant regards as his invention.” 35 U.S.C. § 112, ¶ 2. When “means plus function” language is used in the claims, the specification must set forth “adequate disclosure showing what is meant by that language.” In re Donaldson, 16 F.3d 1189, 1195 (Fed.Cir. 1994). Claim indefiniteness under Section 112, ¶ 2 is a question of law. Exxon Research and Engineering Co. v. U.S., 265 F.3d 1371, 1376 (Fed.Cir. 2001) (“Exxon Research”); Union Pacific Resources Co. v. Chesapeake Energy Corp., 236 F.3d 684, 692 (Fed.Cir. 2001).

“[I]f the claims, read in light of the specification, reasonably apprise those skilled in the art both of the utilization and scope of the invention, and if the language is as precise as the subject matter permits, the courts can demand no more.” Shatterproof Glass Corp. v. Libby-Owens-Ford Co., 758 F.2d 613, 624 (Fed.Cir.), cert. dismissed, 474 U.S. 976 (1985) (“Shatterproof Glass”); accord, Hybritech, Inc.

v. Monoclonal Antibodies, Inc., 802 F.2d 1367, 1385 (Fed.Cir. 1986), cert. denied, 480 U.S. 947 (1987) (“Hybritech”). Further in this connection, the Federal Circuit has observed:

We have not insisted that claims be plain on their face in order to avoid condemnation for indefiniteness; rather, what we have asked is that the claims be amenable to construction, however difficult that task may be. If a claim is insolubly ambiguous, and no narrowing construction can properly be adopted, we have held the claim indefinite. If the meaning of the claim is discernible, even though the task may be formidable and the conclusion may be one over which reasonable persons will disagree, we have held the claim sufficiently clear to avoid invalidity on indefiniteness grounds.

Exxon Research, supra, 265 F.3d at 1375. “By finding claims indefinite only if reasonable efforts at claim construction prove futile,” the Federal Circuit continued in Exxon Research, “we accord respect to the statutory presumption of patent validity.” Id. In this regard, where claims on their face cover various methods that produce widely varying and non-overlapping results such that they “fail to put competitors on notice of the limits of the claimed invention, so that they may fairly know the point at which their activities may begin to pose a serious risk of infringement,” those claims are indefinite under Section 112, ¶ 2. Certain Polyethylene Terephthalate Yarn and Products Containing Same, Inv. No. 337-TA-457, Commission Opinion at 18, 2002 WL 1349938 (U.S.I.T.C., June 18, 2002).

**B. Is the Mark 1 Posisorter prior art to the ‘510 patent?**

According to Vanderlande,<sup>16</sup> a sortation system that predated the accused Mark 2 Posisorter at issue in this investigation was Vanderlande’s Mark 1 Posisorter

---

<sup>16</sup>Since Vanderlande bears the burden of proving invalidity, its contentions on such issues shall be recited first.

system. Vanderlande contends that the Mark 1 Posisorter is prior art to the '510 patent under 35 U.S.C. § 102(f) because the invention of the '510 patent was derived, at least in part, from features of the Mark 1 that Vanderlande disclosed to the inventors prior to the filing of their patent application. RIB 107-09. Vanderlande contends that on March 7, 1990, more than seven months before the '510 patent application was filed on October 31, 1990, drawings of the Mark 1 Posisorter were given by Hans Bodewes of Vanderlande to '510 co-inventor Bernard Woltjer, who in turn provided them to '510 co-inventor David Cotter. RIB 108; RRB 79. As of that date, Vanderlande argues, the named inventors did not have a complete conception of what they argue is the claimed invention in that they had not conceived of an embodiment of their invention in which the shoe did not touch the upper surface of the slat. RIB 108. That idea, Vanderlande argues, came from Vanderlande's Mark 1 Posisorter, in that the Mark 1 drawings show a positive sorter that only contacts the slat underneath the conveying surface and does not contact the upper conveying surface of the slat. RIB 108; RRB 79. That fact, Vanderlande maintains, is all that is necessary to establish the Mark 1 as prior art to the '510 patent. RIB 108. If the claims are interpreted so broadly as to cover a glide surface that does not contact the conveying surface of the slat, Vanderlande argues, then the Mark 1 Posisorter is prior art. RRB 79.

Rapistan contends that the Mark 1 Posisorter is not prior art to the '510 patent. CIB 129-37. Rapistan argues that the Mark 1 was not conceived of by Vanderlande until several months after the date of conception of the inventions

claimed in the '510 patent, and therefore cannot be prior art. CIB 129-30. Woltjer's March 1990 viewing of the concept drawing of the Mark 1 occurred eight months after Rapistan had commenced working on the project that led to the '510 patent, and half a year after the inventors had conceived of most of the claimed elements of the '510 patent and all of the claimed elements that Vanderlande might suggest were present in that concept drawing, Rapistan maintains. CIB 130. According to Rapistan, the inventors had conceived of the final version of the RS200 devices, referred to as the "production intent version," weeks prior to the March 1990 disclosure. *Id.* Further, Rapistan contends, an actual Mark 1 sorter device was neither created nor disclosed by Vanderlande to the named inventors until well after the October 31, 1990 filing date of the '510 patent application. CIB 132. According to Rapistan, the only features of the '510 patented invention that the inventors did not conceive of prior to viewing the Mark 1 concept drawing in March 1990 were the lateral stabilizer means and the inclusion of sloping surfaces that slope downwardly laterally inward and longitudinally forward or rearward, but neither of these features are disclosed in the Mark 1 concept drawing. CIB 135. Concerning Vanderlande's contention that the Mark 1 disclosed a shoe that does not contact the slat's upper surface and that the '510 patent, to the extent that its claims are broad enough to encompass such a feature, is invalid under 35 U.S.C. § 102(f) by reason of that prior disclosure, Rapistan argues that whether or not there is contact between the shoe and the upper surface of the slat is irrelevant since the claims neither require nor exclude such contact. CIB 136; CRB 97-98.

The Staff agrees with Rapistan that the Mark 1 Posisorter is not prior art to the '510 patent. SIB 74-75. According to the Staff, the evidence does not support the conclusion that the invention of the '510 patent was derived in whole or in part from the Mark 1 Posisorter. SIB 75. By February 15, 1990, the Staff argues, Rapistan had designed a shoe and slat very similar to the RS200 that was ultimately manufactured and sold, and also very similar to the description of the preferred embodiment in the '5110 patent. *Id.* By March 16, 1990, the Staff continues, engineering drawings of the new shoe and slat design were sufficiently complete to permit release of the drawings for purchase or manufacture. *Id.* Thus, according to the Staff, the Rapistan inventors had essentially completed the design of their shoe and slat before they saw the sketches of the Mark 1 Posisorter, and the Mark 1 Posisorter had no impact on the development of the RS200. *Id.* Moreover, the Staff argues, Vanderlande's contention that the Mark 1 is prior art if the '510 patent claims are broadly interpreted is unsupported by any case law showing that the prior art status of a reference can be contingent on the interpretation of the claims of the asserted patent. SRB 26-27. Thus, the Staff maintains, the Mark 1 Posisorter does not qualify as prior art to the '510 patent. SIB 75.

As the Staff points out (at SIB 74-75), a patent is invalid on derivation grounds under 35 U.S.C. § 102(f) if someone else conceived the invention earlier than the patentee and communicated that conception to the patentee. Price v. Symsek, *supra*, 988 F.2d at 1190. The communication of the prior conception must be sufficient to enable a person of ordinary skill in the art, "without the exercise of any

ingenuity and special skill on his part, to construct and put the improvement in successful operation.” Gambro, supra, 110 F.3d at 1577. This is a stricter standard than communicating “at least so much of the claimed invention as would have made it obvious to one of ordinary skill in the art,” a standard that the Federal Circuit specifically disavowed in Gambro. See Gambro, supra, 110 F.3d at 1578.

Whereas proving invalidity under 35 U.S.C. § 102(f) requires a showing that the derived invention is more than merely obvious from that which is communicated, proving invalidity under 35 U.S.C. § 103(a) using the communicated information as a prior art reference is another matter. Such information constitutes prior art except when the communicated information and the claimed invention “were, at the time the invention was made, owned by the same person or subject to an obligation of assignment to the same person.” 35 U.S.C. § 103(c); OddzOn Products, Inc. v. Just Toys, Inc., 122 F.3d 1396, 1401-04 (Fed.Cir. 1997) (“OddzOn”).

Rapistan differs with Vanderlande and the Staff over whether the foregoing Federal Circuit precedents permit (according to Vanderlande and the Staff) or preclude (according to Rapistan) the Mark 1 Posisorter concept drawing that Vanderlande showed to one of the co-inventors of the ‘510 patent on March 7, 1990 from being considered as a prior art reference to the ‘510 patent for purposes of an obviousness analysis under 35 U.S.C. § 103(a). See RIB 107-08; RRB 79-80; CIB 131-32; SIB 74-75. Gambro and OddzOn are not in conflict, however. They clearly deal with two different and alternative types of invalidity defense and spring from altogether distinct legal histories. Gambro makes clear that the “enablement, not



obviousness” standard for finding invalidity by reason of derivation under Section 102(f) is a long-standing doctrine that was not overruled by dictum in a particular case. Gambro, supra, 110 F.3d at 1577-78. OddzOn clarifies that before Section 103 was amended in 1984, the patent laws did not generally recognize as prior art “that which is not accessible to the public,” such as the type of information usually communicated under Section 102(f), but the 1984 amendment to Section 103 changed that law by implicitly enacting the rule that, except for commonly-owned subject matter, such information is indeed prior art for the purpose of determining obviousness. OddzOn, supra, 122 F.3d at 1402-03. Thus, a patent may not be invalid under Section 102(f) if the information communicated to the inventor does not enable a person of ordinary skill in the art to make the invention, but may be invalid under Section 103(a) if the differences between the information so communicated and the invention are such that the invention would have been obvious to such a person at the time.

In connection with an obviousness analysis under 35 U.S.C. § 103(a), the prior art reference in question must have existed “at the time the invention was made” in order to be considered. See 35 U.S.C. § 103(a). Thus, prior art for the purpose of applying Section 103 includes only references with effective dates before the date of the invention. See 2 Chisum on Patents § 5.03[2]. The “date of the invention” is presumed to be the filing date of the patent application unless an earlier date is proved. Weathercheem Corp. v. J.L. Clark, Inc., 937 F.Supp. 1262, 1286 (N.D. Ohio 1996). That earlier date can be either (i) the date of reduction to practice

prior to the effective date of the reference, or (ii) the date of conception of the invention prior to the effective date of the reference, coupled with due diligence from said date to a subsequent reduction to practice or to the filing of the application. See 1 Chisum on Patents § 3.08[1].

As the Federal Circuit has often stated:

Conception is the formulation of a definite and permanent idea of the complete and operative invention as it is hereafter to be applied in practice. [citation omitted]. Conception must include every feature or limitation of the claimed invention. [citation omitted]. It turns on the inventor's ability to describe the invention with particularity, and the idea must be sufficiently formed so that only ordinary skill would be necessary to reduce the invention to practice, without extensive research or experimentation. [citation omitted]. Inventor testimony alone is insufficient to prove conception; some form of corroboration must be shown.

Slip Track Systems, Inc. v. Metal Lite, Inc., \_\_\_ F.3d \_\_\_, 2002 WL 31018206 at \*3 (Fed. Cir. 2002) ("Slip Track Systems").

It is stipulated by the parties that on March 7, 1990, more than seven months before the '510 patent application was filed on October 31, 1990, a set of concept drawings of the Mark 1 Posisorter were given by Hans Bodewes of Vanderlande to '510 co-inventor Bernard Woltjer of Rapistan, who in turn provided them to '510 co-inventor David Cotter of Rapistan. Woltjer Tr. 385:25-386:16 and 434:6-10; Cotter Tr. 608:17-20; CX-415C; **FF 25 and 87** (First Stipulation Nos. 25 and 90). The first concept drawing showed an overview of the Mark 1 in action, and the second concept drawing showed a cross-section of the Mark 1 shoe and slat, as follows:

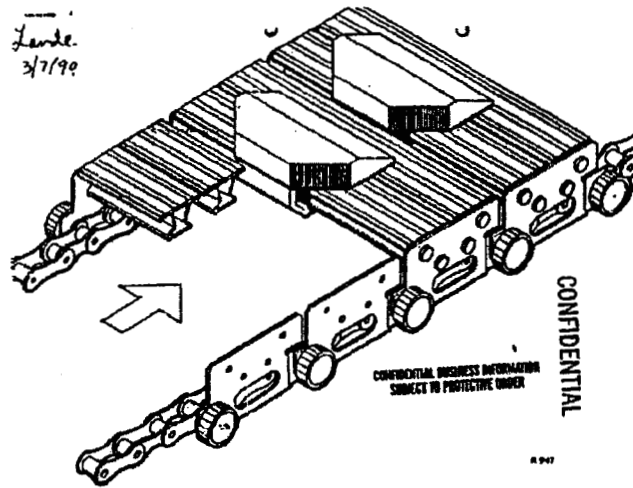

**Mark 1 Posisorter Overview**

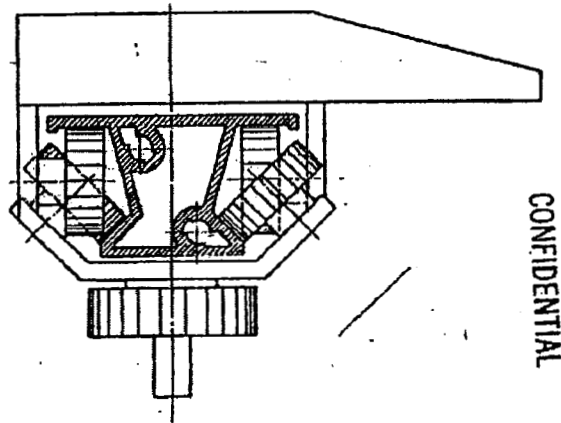

**Mark 1 Posisorter Cross-section**

CX-415C; FF 254. At the time that Woltjer and Cotter of Rapistan received these concept drawings from Bodewes of Vanderlande, Rapistan was already in the middle of designing the RS200 sortation system, which had begun with discussions in 1988

and had proceeded to documentation by at least as early as July 24, 1989. Woltjer Tr. 340:24-345:3; 440:9-14; Cotter Tr. 558:1-559:2; CX-303C; CX-307C; CX-308C; CDX-26; **FF 255**. In its preliminary plans around that date, Rapistan envisioned creating a sortation system using a diverter shoe made of molded plastic and a carrier slat made of extruded aluminum or composite material. Cotter Tr. 560:8-561:5; 670:20-671:20; CX-308C; **FF 256**. On or about August 3, 1989, Rapistan prepared a concept drawing for a trapezoidal slat and shoe prototype. Cotter Tr. 561:6-23; CX-310C; **FF 257**. Around September 8, 1989, Rapistan created a production drawing of that prototype shoe. Woltjer Tr. 345:4-12, 357:15-21; CX-321C; **FF 258**. A production drawing of the prototype slat was created on or about October 20, 1989. Cotter Tr. 563:19-25; CX-339C; **FF 259**. A physical prototype shoe and slat of the design was prepared by Rapistan around December 1989. Woltjer Tr. 357:22-358:10; CPX-13; CPX-14; **FF 260**.

By December 1989, according to Woltjer, the only two claimed elements of the '510 patent that were not yet part of Rapistan's trapezoidal prototype design were the "lateral stabilizing means" of claims 17 and 23, and the "plurality of contiguous, generally planar surfaces sloping downward from an upper extent of said diverting surface laterally inward and longitudinally forward or rearward" of claim 30. Woltjer Tr. 360:13-361:18; CX-321C; **FF 261**.

Rapistan tested the trapezoidal prototype slat and shoe design in January 1990, with less than satisfactory results. Woltjer Tr. 362:14-24; Cotter Tr. 559:3-13; CPX-13; CPX-14; CDX-26; **FF 262**. Those results led to a redesign, shown on

drawings having a so-called "V.A. date" of February 15, 1990 standing for the date on which the manufacturing department agreed upon the final design. Woltjer Tr. 363:18-365:22; Cotter Tr. 559:13-16; CX-403C; CX-422C; **FF 263**. By the following March, Rapistan had confirmed that this new design worked for its intended purpose. Cotter Tr. 657:8-658:15; **FF 264**. By March 16, 1990, Rapistan released its final design for product manufacturing. Woltjer Tr. 365:23-367:10; CX-861C; **FF 265**. This design ultimately became the final RS200 diverter shoe support portion and slat, and also became the preferred embodiment disclosed in the '510 patent. Woltjer Tr. 439:22-440:2; **FF 266**.

The drawings of the redesign show the "lateral stabilizing means of claims 17 and 23 that Woltjer said was not present in the earlier prototype design, but do not show the "plurality of contiguous, generally planar surfaces" of claim 30. CX-403C; CX-422C; **FF 267**. Those surfaces were worked out by co-inventor Curtis LeMay, but a definitive date for his work was not established by Rapistan during the trial. Cotter Tr. 567:20-568:16; CX655C; CX-656C; **FF 268**.

It is evident from the foregoing facts that, at least from the standpoint of the "date of invention," the Mark I Posisorter constitutes a potential prior art reference to only a few, and certainly not all, of the asserted claims of the '510 patent. Rapistan has presented sufficient and corroborated evidence to prove that, by February 15, 1990, prior to learning of the Mark 1 Posisorter on March 7, 1990, it had conceived of "a definite and permanent idea of the complete and operative invention as it is hereafter to be applied in practice" and had diligently reduced to

practice every element of every asserted claim of the '510 patent except for the "plurality of contiguous, generally planar surfaces" element of independent claim 30 and, in turn, of dependent claims 33 and 35. See Slip Track Systems, *supra*. Consequently, the Mark 1 Posisorter cannot be considered a prior art reference to any asserted claim of the '510 patent other than claims 30, 33 and 35.

In connection with those remaining claims, the only reason given by Vanderlande for asserting the Mark 1 Posisorter as a reference is to show that the concept of the shoe not touching the upper surface of the slat was in the prior art. Although this concept is not an express element of any claim of the '510 patent, a prior art reference cannot be ruled out simply because its teachings do not speak directly to the claim elements of the patent at issue. "It is well settled that a prior art reference is relevant for all that it teaches to those of ordinary skill in the art." In re Fritch, 972 F.2d 1260, 1264 (Fed.Cir.1992) (emphasis added). Thus, the relevant teachings of the Mark 1 Posisorter will be considered in analyzing derivation under 35 U.S.C. § 102(f) and obviousness under 35 U.S.C. § 103(a) as a prior art reference in connection with claims 30, 33 and 35 of the '510 patent.

**C. Are claims 1 and 4 of the '510 patent invalid under 35 U.S.C. § 102(f) based on the Mark 1 Posisorter?**

In view of the foregoing conclusion that the Mark 1 Posisorter is not a relevant prior art reference to claims 1 and 4 of the '510 patent, the contention that those claims are invalid under 35 U.S.C. § 102(f) as derived from the Mark 1 Posisorter must be rejected.

**D. Are claims 1 and 4 of the '510 patent invalid under 35 U.S.C. § 103(a) based on the Mark 1 Posisorter?**

In view of the foregoing conclusion that the Mark 1 Posisorter is not a relevant prior art reference to claims 1 and 4 of the '510 patent, the contention that those claims are invalid under 35 U.S.C. § 103(a) based solely on the Mark 1 Posisorter must be rejected.

**E. Are claims 1 and 4 of the '510 patent invalid under 35 U.S.C. § 103(a) based on United States Patent No. 3,361,247 and United States Patent No. 4,884,677?**

U.S. Letters Patent No. 3,361,247 ("the Lauzon '247 patent reference"), entitled "Article Sorting System and Method," issued on January 2, 1968 to James N. Lauzon, Raymond J. Sandner, and Jorgen S. Bildsoe. RX-577; FF 72 and 73 (First Stipulation Nos. 73 and 74). U.S. Letters Patent No. 4,884,677 ("the Yu '677 patent reference"), entitled "Package Sortation Conveyor," issued on December 5, 1989 to Thomas C. Yu, Robert K. Vogt, and John J. Wilkens. RX-602; FF 76 and 77 (First Stipulation Nos. 77 and 78).

The Lauzon '247 and Yu '677 patent references are among the prior art references that were considered by the PTO Examiner during prosecution of the '510 patent at issue. See CX-1 ('510 patent, first page); FF 74 and 78 (First Stipulation Nos. 75 and 79). Consequently, Vanderlande's reliance upon these references must overcome the presumption that the PTO Examiner properly performed the task of evaluating the validity of the '510 patent in view of these references. See American Hoist & Derrick Co. v. Sowa & Sons, Inc., 725 F.2d 1350, 1359 (Fed.Cir.), cert. denied, 469 U.S. 821 (1984) ("American Hoist & Derrick").

Vanderlande contends that claims 1 and 4 of the '510 patent are invalid under 35 U.S.C. § 103(a) as obvious in view of the Lauzon '247 and Yu '677 patent references. RIB 112-15. Vanderlande argues that both the Lauzon '247 and Yu '677 patent references possess many of the elements of claim 1. RIB 113. As for elements of claims 1 and 4 that these references do not possess, Vanderlande contends that a person of ordinary skill in the art facing the advantages and disadvantages of both would have taken pieces from both systems and combined them. RIB 112.

In particular, Vanderlande argues, although the circular cylindrical slats of Yu'677 do not constitute "an outer surface having a planar upper portion defining said conveying surface," a person of ordinary skill in the art would have been motivated to use a slat having a flat upper portion, such as that used with Lauzon '247, in order to solve the problems associated with roller conveyors such as Yu '677. RIB 114. Concerning the requirement of claim 1 that "each of said diverter shoes hav[e] a support portion including a substantially continuous glide surface surrounding said wall, said glide surface having substantially the same configuration as the outer surface of the slat," Vanderlande contends that both the Lauzon '247 and Yu '677 patent references have this limitation if it is interpreted to require only a surface that moves easily, regardless of contact, and that the diverter shoes of both references surround each slat, are substantially continuous, and have the same configuration as the slat. RIB 114. Finally, in connection with the added limitation of dependent claim 4 "wherein each of said slats is formed by extrusion," Vanderlande contends that a person of ordinary skill in the art would make the slats



of Lauzon '247 or Yu '677 by extrusion because it was less expensive and more accurate than formed sheet metal. RIB 115.

Vanderlande also argues that Rapistan has not shown any objective indicia of non-obviousness, so-called "secondary considerations," by failing to show a nexus between the commercial success of its sortation system and the RS200 portion of it, and by failing to show its relative share of the relevant market for sortation systems. RRB 84-85. Vanderlande also contends that Rapistan has not shown any long-felt need in the industry because the delay in developing such systems had more to do with the development of plastics with correct characteristics. RRB 85. Finally, Vanderlande argues that its use of a rolling diverter shoe for the Union Transport contract does not show a teaching away from the invention of the '510 patent at the time of the invention, but instead shows a use of the best design for the very demanding requirements of the Union Transport sorter. RRB 86.

Rapistan contends that the Lauzon '247 and Yu '677 patent references do not render claims 1 and 4 of the '510 patent obvious under 35 U.S.C. § 103(a). CIB 140-142. Rather, Rapistan argues, Vanderlande's obviousness analysis is only a hindsight reconstruction of the invention of the '510 patent using the Lauzon '247 and Yu '677 references. CRB 105-06. In particular, Rapistan contends, the Lauzon system utilized two separate elements, one being the flat-topped slat and the other being a through-rod for providing guidance and stabilization to the diverter shoe. CIB 140; CRB 106. Lauzon '247 used rollers as the contact between the slat and the shoe, which is not a glide surface as in the invention of claims 1 and 4 of the '510 patent.

CIB 140; CRB 106. The slat of the Lauzon '247 device is not a right cylinder, according to Rapistan, and a person of ordinary skill in the art would not have been motivated to close this gap because it would have destroyed the device's functionality. CRB 107. Concerning the Yu '677 tube sorter system, Rapistan contends that such systems suffered from a significant problem of large gaps between the circular tubes that permitted materials to jam the sorter. CIB 141-42. It would not have been obvious to modify the Yu device to include a flat-topped slat, Rapistan argues, because such a modification would have increased the material costs of the Yu device. CRB 107-08. Prior to the '510 patent, Rapistan contends, no one had ever devised a way to merge the flat-top slat designs with sliding shoes, and the conventional thinking was that the two separate designs were not compatible. CRB 106. Even if one were to combine the Yu and Lauzon references, neither discloses or suggests a shoe with a glide surface that surrounds the slat, as required by claims 1 and 4. CRB 108.

[

] CIB 144-45. Rapistan also contends that the sortation industry experienced a long-felt need for some 20-25 years before Rapistan's invention, and that others tried and failed to fulfill that need. CIB 145.

The Staff contends that claims 1 and 4 of the '510 patent are not rendered obvious by a combination of the Lauzon '247 and Yu '677 patent references. SIB 77.

According to the Staff, these two patents are directed to distinct classes of sorters, and combining their features would not have been obvious to a person of ordinary skill in the art. Id. Further, the Staff contends, there is considerable objective evidence of non-obviousness. Id.

Figure 15 of the Lauzon '247 patent and Figure 9 of the Yu '677 patent show cross-sections of the two prior-art references that depict all of the features relevant to this obviousness analysis:

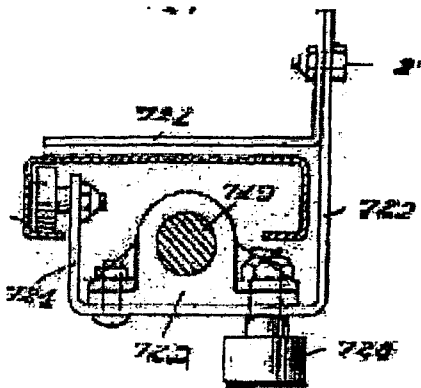

Lauzon '247 Fig. 15

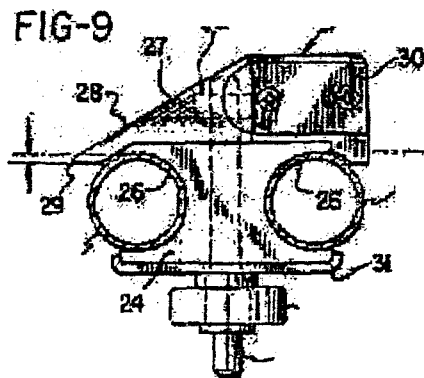

Yu '677 Fig. 9

RX-577; RX-602; FF 269.

As required by claim 1 of the '510 patent, both the Lauzon '247 and Yu '677 patent references are conveying systems "having a longitudinally moving conveying surface" made up of the top set of a series of slats connected at opposite ends by a pair of endless chains. Hoet Tr. 1873:20-21, 1881:20-23; RX-577 (Lauzon '247 patent, col. 6:56-62; Figs. 1-11 and 17); RX-602 (Yu '677 patent, col. 2:63-3:10 and Figs. 1-2); **FF 270**. Both Lauzon '247 and Yu '677 have the required "plurality of diverter shoes . . . for lateral movement with respect to the conveying surface," but only in the Lauzon '247 reference is each shoe "moveably mounted on one of said slats" (emphasis added). Hoet Tr. 1881:24-25; Radcliffe Tr. 1389:14-23; CDX-27 at 5; RX-577 (Lauzon '247 patent, Fig. 15); RX-602 (Yu '677 patent col. 3:13-17 and Figs. 1, 2 and 9); **FF 271**. Both systems have "track means for imparting a lateral force to move said diverter shoes laterally to displace product positioned on said conveying surface." Hoet Tr. 1873:24-1874:2, 1882:1-2; RX-577 (Lauzon '247 patent, col. 7:62-13:37); RX-602 (Yu '677 patent, col. 3:18-24, 5:38-49, and Figs. 1-2, 5 and 10-14); **FF 272**.

The slats of the Yu '677 system are "defined by a wall formed as a right cylinder." Hoet Tr. 1882:3-4; RX-602 (Yu '677 patent, Fig. 9); **FF 273**. The slats of the Lauzon '247 system are not closed walls, but rather have a "C"-shaped cross-section (i.e., open at the bottom) and therefore are not "right cylinders." Radcliffe Tr. 2207:17-21; CDX-27 at 4; RX-577 (Lauzon '247 patent, col. 7:39-40 and Fig. 15); **FF 274**. The walls of the slats of the Lauzon '247 system include "an outer surface having a planar upper portion defining said conveying surface," but the walls of the

slats of the Yu '677 system, being circular cylinders, do not have a planar upper portion. Hoet Tr. 1874:16-20; Radcliffe Tr. 2214:18-2215:12; CDX-27 at 5; RX-577 (Lauzon '247 patent, Fig. 15); RX-602 (Yu '677 system, Fig. 9); **FF 275**.

Both the Lauzon '247 and Yu '677 systems have "a support portion." Hoet Tr. 1877:10-16; 1882:5-6; RX-577 (Lauzon '247 patent, Fig. 15); RX-602 (Yu '677 patent, Fig. 9); **FF 276**. However, in neither system does the support portion include "a substantially continuous glide surface surrounding said wall, said glide surface having substantially the same configuration as said outer surface of said slat." Instead, the shoe of the Lauzon '247 reference is supported by rolling bearings and does not have a glide surface that glides along the slat or surrounds the slat. Radcliffe Tr. 2207:17-2208:2; CDX-27 at 4; RX-577 (Lauzon '247 patent, Fig. 15); **FF 277**. The shoe of the Yu '677 reference has a glide surface, but it is not continuous, does not surround the slat, and does not have substantially the same configuration as the outer surface of the slat. Radcliffe Tr. 2214:18-2216:19; CDX-27 at 5; RX-602 (Yu '677 patent, Fig. 9); **FF 278**.

In connection with the element of dependent claim 4 "wherein each of said slats is formed by extrusion," neither the Lauzon '247 patent nor the Yu '677 patent indicate that their slats are so made, but there is undisputed evidence in the record that extrusion would have resulted in a cheaper manufacturing process. Cotter Tr. 534:20-535:6; Hoet Tr. 1875:24-1876:3, 1879:23-24; **FF 279**. Accordingly, a person of ordinary skill in the art would have been motivated to form the slats of Lauzon '247 and Yu '677 by extrusion.

In connection with “a reason, suggestion, or motivation in the prior art that would lead one of ordinary skill in the art to combine the references and that would also suggest a reasonable likelihood of success,” Smiths Industries, supra, Vanderlande relies only on the professed “ordinary knowledge of those skilled in the art,” WMS Gaming, supra, in connection with the Lauzon ‘247 and Yu ‘677 references in order to substitute the desirable characteristics of one, if any, for undesirable or missing characteristics of the other to come up with each of four elements of claims 1 and 4, namely: (i) the mounting of each diverter shoe on only one slat (missing from Yu ‘677 but present in Lauzon ‘247); (ii) forming the wall of each slat as a right cylinder (missing from Lauzon ‘247 but present in Yu ‘677); (iii) each slat having a planar upper portion (missing from Lauzon ‘247 but present in Yu ‘677); and (iv) forming slats by extrusion (missing from both). As for the element in claim 1 of “a substantially continuous glide surface surrounding said wall” and having “substantially the same configuration” as the slat that is missing from both references, Vanderlande relies on an overly broad interpretation of that claim element and a vague motivation on the part of the person of ordinary skill in the art to reduce costs by substituting glide surfaces for wheel bearings. See Hoct Tr. 2094:13-2098:3.

Other than forming slats by extrusion as required by claim 4, none of Vanderlande’s reasons persuasively explain or clearly and convincingly demonstrate why a person of ordinary skill in the art would make such substitutions, or why such a person would consider those substitutions to have a reasonable likelihood of success, given the differing basic modes of operation of the systems of the Lauzon

'247 and Yu '677 patents and the relative advantages and disadvantages of each. Indeed, as Hoet admitted on cross-examination, "if you do remove parts from any sorter, whether it's the RS 200 shoe or slat or the Mark 2 shoe and slat, you destroy its operation. I mean, that's common. You take it apart, it won't work anymore." Hoet Tr. 2091:16-20; FF 280. As the Federal Circuit has held, "a proposed modification [is] inappropriate for an obviousness inquiry when the modification render[s] the prior art reference inoperable for its intended purpose." In re Fritch, supra, 972 F.2d at 1266 n.12.

[

] Brouckman Tr. 223:16-224:25;

CDX-11C; CDX-12C; FF 281. [

] Brouckman Tr. 224:2-25; CDX-

11C; CDX-12C; FF 282.

[

]

Brouckman Tr. 272:23-276:6; CDX-11C; CDX-12C; FF 283. The RS200T system

has a tube-type conveyor that is built within the framework of the RS200, using the frame, drive components and switch components of the RS200. Woltjer Tr. 355:10-20; **FF 284**. [

] Woltjer Tr. 355:21-356:11; **FF 285**. Although there is no evidence in the record that such systems meet the requirements of any claim of the '510 patent, the evidence also does not demonstrate that tube-type sorters represent a large portion of Rapistan's RS200 sales volume.

To accord substantial weight to objective evidence of non-obviousness, a nexus must be shown between the evidence and the merits of the claimed invention. In re GPAC, supra. Here, Rapistan presented the testimony of Dale Manzel, a director of distribution centers and material handling systems for K-Mart Corporation, who purchased an RS200 system in April 1991 for installation at K-Mart's Ocala, Florida distribution facility. Manzel Tr. 289:1-6; 290:16-291:2; 293:5-7; **FF 286**. According to Manzel, the RS200 demonstrated increased throughput and product conveyability over its predecessor that K-Mart also utilized, the Rapistan PS140 sortation system. Manzel Tr. 291:3-24; **FF 287**. In terms of "conveyability," Manzel explained that the old PS140 was a tube sorter that had gaps between the rollers, whereas the RS200 is a fairly flat surface. Manzel Tr. 291:18-24; **FF 288**. In the former, products could fall into the gaps between the rollers and cause jams and blowups, whereas the RS200 with its flat conveying surface would keep sorting under such conditions. Manzel Tr. 291:25-294:1; **FF 289**. After purchasing an



RS200 system for the Ocala facility, K-Mart purchased additional RS200s. Manzel Tr. 294:2-7; **FF 290**. This evidence demonstrates the requisite nexus, “both that there is commercial success, and that the thing (product or method) that is commercially successful is the invention disclosed and claimed in the patent.” In re GPAC, supra.

Rapistan also argues that there was a long-felt need in the sortation industry for some 20-25 years before the invention of the ‘510 patent that others tried and failed to fulfill, notwithstanding the presence of all of the technology necessary to create the invention. CIB 145. Rapistan also contends that Vanderlande was skeptical of Rapistan’s approach, as exemplified by the prior art approach that it took in connection with its own product. Id. Vanderlande counters that the delay in the industry was caused by delay in the development of plastics by third parties rather than inability to fulfill this long-felt need. RRB 85-86. As for its own products, particularly in developing and installing a sortation system for the Union Transport facility, Vanderlande contends that its design choices met the very demanding requirements of the contract that impelled Vanderlande to choose a rolling shoe design rather than a sliding shoe design. RRB 86. Unlike the objective evidence of commercial success discussed above, these other objective indicia of non-obviousness are inconclusive.

Although depending from claim 1, claim 4 claim carries an independent presumption of validity and stands or falls separately from claim 1. Continental Can, supra, 948 F.2d at 1266-67. However, a dependent claim is “construed to incorporate

by reference all the limitations of the claim to which it refers.” 35 U.S.C. § 112, ¶ 4. Here, not all of the elements of claim 1 have been found to be obvious, and claim 4 merely adds the slat extrusion element to those of claim 1 which, in view of the Lauzon ‘247 and Yu ‘677 devices, was well known in the art at the time of the invention. Consequently, taking all elements of claims 1 and 4 as incorporated together in assessing the validity of claim 4, claim 4 has not been shown to be obvious in view of the Lauzon ‘247 and Yu ‘677 references. Cf. Scheller-Globe Corp. v. Milsco Mfg. Co., 206 U.S.P.Q. 42, 54 (E.D. Wisc. 1979), aff’d in relevant part, 636 F.2d 177 (7th Cir. 1980) (“The remaining dependent claims include subsidiary elements which themselves are old and well known in the urethane art. [transcript citation omitted] They stand or fall with the two main claims.”).

Accordingly, for the foregoing reasons, Vanderlande has not demonstrated clearly and convincingly that claims 1 and 4 of the ‘510 patent are invalid under 35 U.S.C. § 103(a) based on the Lauzon ‘247 and Yu ‘677 patent references.

**F. Is claim 1 of the ‘510 patent invalid under 35 U.S.C. § 102(b) based on French Publication 2,388,737?**

French published patent application 2,388,737 (“the CML ‘737 reference”), entitled “Facility for transferring and sorting miscellaneous objects,” was published on November 24, 1978, and named as applicant Francesco Canziani. RX-220; FF 291. The CML ‘737 reference was not among the prior art references that were considered by the PTO Examiner during prosecution of the ‘510 patent at issue. See CX-1 (‘510 patent, first page); FF 84 and 85 (First Stipulation Nos. 85 and 86). What Rapistan and Vanderlande agree is a physical counterpart of the embodiment

disclosed in the CML '737 reference was introduced into evidence at trial as exhibit RPX-9. CIB 141; Hoet Tr. 2080:24-2081:1.

Vanderlande contends that claim 1 of the '510 patent is invalid under 35 U.S.C. § 102(b) as anticipated by the CML '737 reference. RIB 115-16. Vanderlande argues the CML '737 reference possesses all of the elements of claim 1. Id.

Rapistan contends that the CML '737 reference does not anticipate claim 1 under 35 U.S.C. § 102(b). CIB 141; CRB 109-10. In particular, Rapistan contends, the slats of the CML '737 device are not right cylinders as required by claim 1. CRB 109. The diverter shoes of the device, according to Rapistan, do not have a glide surface, but instead move from one side of the conveyor to another side by way of a roller carriage positioned underneath the slats. CRB 109-10. Even if the arms or surfaces of the shoe were deemed to be glide surfaces, Rapistan maintains, they would not meet the claim 1 requirement that the glide surface surround the slat wall. CRB 110. The shoes only sit above and between the slats, according to Rapistan, do not extend along the underside of the slats, and do not surround the ends of the two outermost slats that lie underneath the pusher shoe. Id.

The Staff agrees with Rapistan that the CML '737 reference does not anticipate claim 1 of the '510 patent. SIB 77. The Staff points out that the CML device lacks a slat in the shape of a right cylinder, and lacks a glide surface as that term is used in claim 1. Id.

As required by 35 U.S.C. § 102(b) for anticipation purposes, the CML '737 reference was published in France more than one year prior to the date of the

application for the '510 patent in the United States. See 35 U.S.C. § 102(b); RX-220; FF 293. Figures 7, 8 and 9 of the CML '737 reference best show the combination of slats (items 30 and 31) and shoes (item 7) disclosed in this reference:

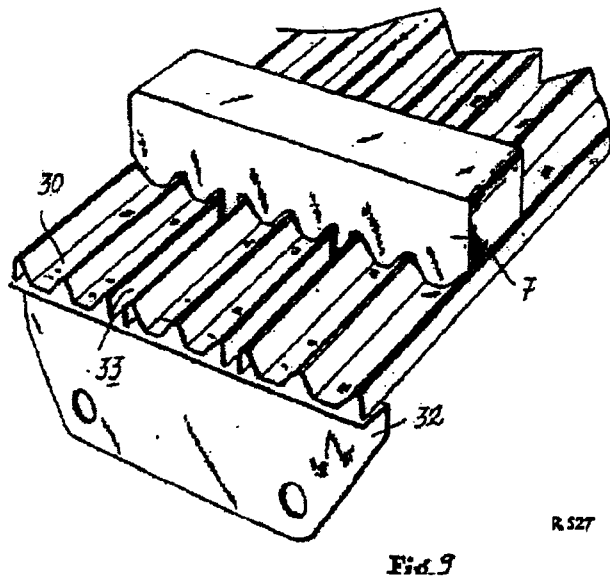
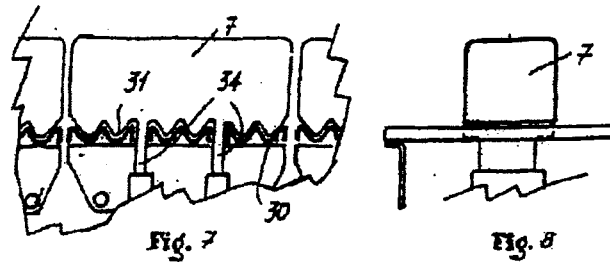

RX-220; FF 294. The reference discloses in the text that the shoes are connected to carriages that “reduce the friction against” sliding rods underneath the slats. RX-220 (CML '737 reference at 2388737); FF 295. Although the reference does not specify how the carriages “reduce the friction” against the “sliding rods,” the physical

counterpart of the CML '737 reference uses rollers for this purpose. Radcliffe Tr. 2210:3-14; RPX-9; **FF 296**.

As required by claim 1 of the '510 patent, the CML '737 reference discloses “a conveying system having a longitudinally moving conveying surface defined by the uppermost ones of a plurality of slats connected at opposite ends in spaced relation with each other to a pair of endless chains.” Hoet Tr. 1878:17-21; RX-220 (CML '737 reference, Figs. 1-3); **FF 297**. The CML '737 reference has the required “plurality of diverter shoes . . . for lateral movement with respect to the conveying surface.” Hoet Tr. 1878:22-24; RX-220 (CML '737 reference, Figs. 1-3 and 7-9); **FF 298**. The parties do not dispute that each shoe is “moveably mounted on one of said slats,” namely, the middle of a series of three slats. **FF 299**. The CML '737 reference also has “track means for imparting a lateral force to move said diverter shoes laterally to displace product positioned on said conveying surface.” Hoet Tr. 1878:25-1879:2; RX-220 (CML '737 reference at 4-6 and Figs. 5 and 6); **FF 300**.

The limitation of claim 1 requiring that each of the slats must be “defined by a wall formed as a right cylinder” is not present in the CML '737 device. Radcliffe Tr. 2211:4-14; CDX-27 at 7; RX-220 (CML '737 reference Fig. 7); **FF 301**. Vanderlande argues that the slat of the CML device should be considered a right cylinder if this limitation covers the Mark 2 Posisorter slat, with its internal and external projections and sharp angles. RIB 116. However, although there can be projections and angularity to a “right cylinder” as that term is used in claim 1 and construed herein, that is not the totality of the term’s construction. A “right cylinder”

as construed herein is a surface that intersects a perpendicular plane at a curve consisting of a generally closed loop, which is not the case with the slats of the CML '737 device. RX-220 (CML '737 reference Fig. 7); **FF 302**.

Each slat of the CML '737 device has "an outer surface having a planar upper portion defining said conveying surface." Hoet Tr. 1879:6-9; RX-220 (CML '737 reference, Figs. 7 and 9); **FF 303**. However, this outer surface is not included in "a wall formed as a right cylinder," as explained above, and therefore does not satisfy claim 1 in this respect. Radcliffe Tr. 2211:12-14; CDX-27 at 7; **FF 304**.

The diverter shoe of the CML '737 reference has "a support portion" as claim 1 requires. Hoet Tr. 1879:10-12; RX-220 (CML '737 reference, Figs. 7-9); **FF 305**. However, the support portion of the CML '737 device does not include "a substantially continuous glide surface surrounding said wall, said glide surface having substantially the same configuration as said outer surface of said slat" as claim 1 requires and as construed herein. Instead, the shoe of the CML '737 reference is supported by roller bearings and does not have a glide surface that glides along the slat or surrounds the slat. Radcliffe Tr. 2211:20-2212:7; CDX-27 at 7; RX-220 (CML '737 reference, Figs. 4 and 7-8); RPX-9; **FF 306**.

Accordingly, for the foregoing reasons, Vanderlande has not demonstrated clearly and convincingly that claim 1 of the '510 patent is invalid under 35 U.S.C. § 102(b) as anticipated by the CML '737 reference.

**G. Is claim 4 of the '510 patent invalid under 35 U.S.C. § 103(a) based on French Publication 2,388,737?**

In connection with the limitation of dependent claim 4 of the '510 patent that "each of said slats is formed by extrusion," Vanderlande argues that a person of ordinary skill in the art would make the slats by extrusion because it was less expensive and more accurate than formed sheet metal, as used in the device of the CML '737 reference. RIB 117. Rapistan and the Staff disagree, citing the multiple structural changes that would have been necessary and the lack of any evidence from Vanderlande that extrusion was possible or desirable prior to the invention of the '510 patent. CRB 110-11; SIB 77.

The evidence in the record is undisputed that the stamped slats of the CML '737 device are expensive compared to extruded slats. Hoet Tr. 1879:23-24; FF 307. This consideration would have provided sufficient motivation for a person of ordinary skill in the art at the time of the invention to substitute extruded slats for stamped slats. Hence, the element in claim 4 of forming slats by extrusion is an obvious modification over the prior art to one of ordinary skill.

Although Rapistan and the Staff point to the same objective indicia of non-obviousness discussed earlier herein as applying equally to this instance, the objective evidence of commercial success of the RS200 sortation system found to exist in connection with claim 1 must be considered in connection with claim 4 as well, but does not necessarily control the obviousness determination in this instance. Richardson-Vicks, *supra*, 122 F.3d at 1483-84.

As explained previously in connection with the non-obviousness of claim 4 in view of the Lauzon '247 and Yu '677 references, claim 4 carries an independent presumption of validity and does not stand or fall with claim 1. Continental Can, supra, 948 F.2d at 1266-67. Nevertheless, a dependent claim is "construed to incorporate by reference all the limitations of the claim to which it refers." 35 U.S.C. § 112, ¶ 4. Here, not all of the elements of claim 1 have been found to be anticipated by the CML '737 reference, and claim 4 merely adds the slat extrusion element which, in view of the CML device, was well known in the art at the time of the invention. Consequently, taking all elements of claims 1 and 4 as incorporated together in assessing the validity of claim 4, claim 4 is not obvious in view of the CML '737 device.

**H. Are claims 13 and 17 of the '510 patent invalid under 35 U.S.C. § 102(f) based on the Mark 1 Posisorter?**

In view of the foregoing conclusion that the Mark 1 Posisorter is not a relevant prior art reference to claims 13 and 17 of the '510 patent, the contention that those claims are invalid under 35 U.S.C. § 102(f) as derived from the Mark 1 Posisorter must be rejected.

**I. Are claims 13 and 17 of the '510 patent invalid under 35 U.S.C. § 103(a) based on the Mark 1 Posisorter?**

In view of the foregoing conclusion that the Mark 1 Posisorter is not a relevant prior art reference to claims 13 and 17 of the '510 patent, the contention that those claims are invalid under 35 U.S.C. § 103(a) based solely on the Mark 1 Posisorter must be rejected.



**J. Are claims 13, 17, 20 and 22 of the '510 patent invalid under 35 U.S.C. § 103(a) based on United States Patent No. 3,361,247 and either United States Patent No. 4,884,677 or United States Patent No. 4,738,347?**

The Lauzon '247 and Yu '677 patents have already been discussed as prior art references in connection with claim 1 of the '510 patent. In addition, U.S. Letters Patent No. 4,738,347 ("the Brouwer '347 patent reference"), entitled "Diverter Shoe and Diverting Rail," issued on April 19, 1988 to Gerald A. Brouwer, William J. Campbell, Charles W. Saur and Bernard H. Woltjer. RX-333; FF 80 and 81 (First Stipulation Nos. 81 and 82). As with the Lauzon '247 and Yu '677 patent references, the Brouwer '347 patent reference is among the prior art references that were considered by the PTO Examiner during prosecution of the '510 patent at issue. See CX-1 ('510 patent, first page); FF 82 (First Stipulation No. 83). Consequently, Vanderlande's reliance upon these references must overcome the presumption that the PTO Examiner properly performed the task of evaluating the validity of the '510 patent in view of these references. See American Hoist & Derrick, supra.

Vanderlande contends that claims 13, 17, 20 and 22 of the '510 patent are invalid under 35 U.S.C. § 103(a) as obvious in view of the combination of the Lauzon '247 patent with either the Yu '677 patent or the Brouwer '347 patent. RIB 118-21. Vanderlande argues that all three references satisfy the limitations in claim 13 of "a conveying system having a longitudinally moving conveying surface defined by the uppermost ones of a plurality of slats connected in spaced relation with each other in an endless web," and a "track means engaging said diverter shoes for imparting a lateral force to move said diverter shoes laterally to displace product

positioned on said conveying surface.” RIB 118-19. As for all of the other limitations of claims 13, 17, 20 and 22, Vanderlande argues that a person of ordinary skill in the art would have been motivated to design various features or that a properly broad interpretation of the claim term means that one of the references has the limitation. RIB 119-21. As explained earlier herein in connection with claim 1, Vanderlande also argues that Rapistan has not shown any objective indicia of non-obviousness. RRB 84-85.

Rapistan contends that the Lauzon ‘247, Yu ‘677 and Brouwer ‘347 patent references do not render claims 13, 17, 20 and 22 of the ‘510 patent obvious under 35 U.S.C. § 103(a). CRB 115-21. Rapistan argues that none of the three references disclose the claim 13 requirement of a bearing means between at least one joining edge of the slat and an engaging portion of the glide surface. CRB 116-17. Rapistan also argues that Vanderlande’s obviousness analysis is only a hindsight reconstruction of the invention of the ‘510 patent using the Brouwer ‘347 reference. CRB 117-18. Rapistan further contends that Vanderlande’s proposed modifications to the Lauzon, Brouwer and Yu references are contrary to the conventional thinking at the time of the ‘510 patent. CRB 118-19.

In connection with the lateral stabilizer means of claim 17, Rapistan argues that none of the three references relied upon by Vanderlande discloses any such structure. CRB 119. As for claim 20, which requires the support portion of the diverter shoe to be molded of a polymeric material, there is no motivation to modify the Lauzon device to be made of plastic. *Id.* As for claim 22, which requires the

support portion to be defined by a multiplicity of joined wall segments of substantially the same thickness, Rapistan dismisses Vanderlande's obviousness contention as "overly simplistic." CRB 120. According to Rapistan, the modifications proposed by Vanderlande to the Lauzon device are of such extent that it is doubtful that any walls of substantially the same thickness would remain. Id.

The Staff contends that claims 13, 17, 20 and 22 of the '510 patent are not rendered obvious by a combination of the Lauzon '247, Yu '677 and Brouwer '347 patent references. SIB 78-79. According to the Staff, these patents are directed to distinct classes of sorters, and combining their features would not have been obvious to a person of ordinary skill in the art. SIB 79. Further, the Staff contends, there is considerable objective evidence of non-obviousness. Id.

In addition to Figure 15 of the Lauzon '247 patent and Figure 9 of the Yu '677 patent which have already been depicted herein, Figure 4 of the Brouwer '347 patent shows a cross-section of the prior art device that depicts all of the features relevant to this obviousness analysis:

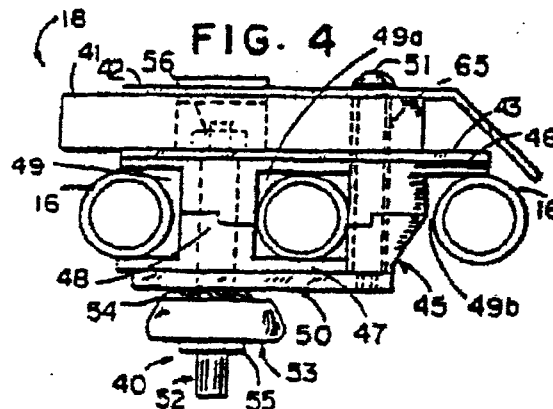

**RX-333; FF 308.**

The Lauzon '247, Yu '677 and Brouwer '347 patent references all satisfy the requirement in claim 13 that they are “conveying system[s] having a longitudinally moving conveying surface defined by the uppermost ones of a plurality of slats connected in spaced relation with each other in an endless web.” Hoet Tr. 1873:20-21, 1879:25-1880:3, 1881:20-23; RX-333 (Brouwer '347 patent, col. 3:30-31 and Fig. 1); RX-577 (Lauzon '247 patent, col. 6:56-62; Figs. 1-11 and 17); RX-602 (Yu '677 patent, col. 2:63-3:10 and Figs. 1-2); **FF 309**. All three references have the required “plurality of diverter shoes . . . for lateral movement with respect to the conveying surface,” but only in the Lauzon '247 reference is each shoe “moveably mounted on one of said slats” (emphasis added). Hoet Tr. 1881:24-25; Radcliffe Tr. 2217:9-2219:12, 1389:14-23; CDX-27 at 5 and 6; RX-333 (Brouwer '347 patent, Fig. 4); RX-577 (Lauzon '247 patent, Fig. 15); RX-602 (Yu '677 patent col. 3:13-17 and Figs. 1, 2 and 9); **FF 310**. All three systems have “track means engaging said diverter shoes for imparting a lateral force to move said diverter shoes laterally to displace product positioned on said conveying surface.” Hoet Tr. 1873:24-1874:2, 1880:6-8, 1882:1-2; RX-333 (Brouwer '347 patent, col. 3:31-51 and Figs. 1 and 2); RX-577 (Lauzon '247 patent, col. 7:62-13:37); RX-602 (Yu '677 patent, col. 3:18-24, 5:38-49, and Figs. 1-2, 5 and 10-14); **FF 311**.

The slat of the Lauzon '247 patent has a wall having a “generally planar” upper portion as required by claim 13, but, having a “C”-shaped cross-section (i.e., open at the bottom), does not have any lower wall at all, much less a “generally

planar” lower wall. Radcliffe Tr. 2207:17-21; RX-577 (Lauzon ‘247 patent, col. 7:39-40; Fig. 15); **FF 312**. The slats of the Brouwer ‘347 and Yu ‘677 patents, having circular tubes, have no “generally planar” upper or lower wall portions at all. Radcliffe Tr. 2214:18-2215:15, 2217:9-24; CDX-27 at 5 and 6; RX-333 (Brouwer ‘347 patent, Fig. 4); RX-602 (Yu ‘677 system, Fig. 9); **FF 313**.

The upper wall portion of the slat of the Lauzon ‘247 patent is “joined by side wall portions defining joining edges between each of said wall portions.” Hoet Tr. 1876:8-11; RX-577 (Lauzon ‘247 patent, Fig. 15); **FF 314**. The Brouwer ‘347 and Yu ‘677 patents, having circular tubes, have neither side walls nor joining edges. Radcliffe Tr. 2214:18-2215:17, 2217:9-2218:1; CDX-27 at 5 and 6; RX-333 (Brouwer ‘347 patent, Fig. 4); RX-602 (Yu ‘677 system, Fig. 9); **FF 315**.

In all three references, the diverter shoes have “a support portion.” Hoet Tr. 1877:10-16, 1880:19-20, 1882:5-6; RX-333 (Brouwer ‘347 patent, Fig. 4); RX-577 (Lauzon ‘247 patent, Fig. 15); RX-602 (Yu ‘677 patent, Fig. 9); **FF 316**. In neither the Lauzon ‘247 device nor the Yu ‘677 device, however, does the support portion include “a glide surface surrounding said wall.” Instead, the shoe of the Lauzon ‘247 reference is supported by rolling bearings and does not have a glide surface that glides along the slat or surrounds the slat. Radcliffe Tr. 2207:17-2208:2; CDX-27 at 4; RX-577 (Lauzon ‘247 patent, Fig. 15); **FF 317**. The shoe of the Yu ‘677 reference has a glide surface, but it does not surround the slat. Radcliffe Tr. 2214:18-2216:19; CDX-27 at 5; RX-602 (Yu ‘677 patent, Fig. 9); **FF 318**. On the other hand, the shoe of the Brouwer ‘347 patent has one glide surface that surrounds the wall of the

middle one of the three slats on which it glides. Hoet Tr. 1880:21-23; Radcliffe Tr. 2218:14; RX-333 (‘Brouwer ‘347 patent, Fig. 4); **FF 319**.

None of the three references has the element in claim 13 of a “bearing means defining a bearing between at least one of said joining edges of each of said slats and an engaging portion of said glide surface of the corresponding one of said diverter shoes.” The Lauzon ‘247 patent, having no glide surface, has no such bearing at any joining edge. Radcliffe Tr. 2207:12-2208:9; CDX-27 at 4; RX-577 (Lauzon ‘247 patent, Fig. 15); **FF 320**. Each of the Brouwer ‘347 and Yu ‘677 patents, having multiple circular tubes for slats that have no joining edges, has no such bearing at the glide surface. Radcliffe Tr. 2214:18-2216:7, 2216:20-2218:23; CDX-27 at 4 and 5; RX-333 (Brouwer ‘347 patent, Fig. 4); RX-602 (Yu ‘677 patent, Fig. 9); **FF 321**.

In connection with the element in dependent claim 17 of “means defining lateral stabilizing means” that can “resist[ ] vertical-axis reaction-force-couples,” the evidence of record does not sufficiently show whether the Lauzon ‘247 device or the Yu ‘677 device have such means. The Brouwer ‘347 patent does not have structure that is identical to that disclosed in the ‘510 patent consisting of a set of vertical surfaces associated with a single slat and a single shoe. Radcliffe Tr. 2217:9-2219:1; CDX-27 at 6; RX-333 (Brouwer ‘347 patent, Fig. 4); **FF 322**. However, the Brouwer ‘347 patent has equivalent structure that performs the same function as the disclosed structure of the ‘510 patent. Hoet Tr. 1881:6-8; Radcliffe Tr. 1133:2-1136:3; RX-330 (Brouwer ‘347 patent, col. 6:67-7:7 and Fig. 4); RDX-74; **FF 323**. Therefore, the Brouwer ‘347 patent satisfies this claim element.

In connection with the element in dependent claim 20 “wherein said support portion is molded of a polymeric material,” the shoe of the Lauzon ‘247 patent is made of metal. Hoet Tr. 1877:4-5; FF 324. However, the Yu ‘677 device satisfies this element in that it includes a body base 24 that is a molded polymer. Hoet Tr. 1883:7-9; RX-602 (Yu ‘677 patent, col. 4:4-8 and Fig. 9, item 24); FF 325. The Brouwer ‘347 patent also satisfies this element in that the shoe consists of a “body 45” having an “upper portion 46” and a “lower portion 47” that overall is “preferably made from a rigid plastic material.” Hoet Tr. 1881:9-11; RX-333 (Brouwer ‘347 patent, cols. 4:31-32, 5:4-5 and Fig. 4); FF 326. As these references show, plastics were well-known and used in the sortation industry at the time of the invention of the ‘510 patent, and a person of ordinary skill would have been motivated to use plastics to make a diverter shoe. Hoet Tr. 1871:7-1872:4, 2079:8-15; RDX-92; FF 327. Accordingly, a person of ordinary skill in the art would have been motivated to mold the diverter shoes of the Lauzon ‘247 device of a polymeric material.

Finally, in connection with the element in dependent claim 22 “wherein said support portion is defined by a multiplicity of joined wall segments having substantially the same thickness,” the shoe of the Lauzon ‘247 patent meets this limitation. RX-577 (Lauzon ‘247 patent, Fig. 15); FF 328.<sup>17</sup> The support portions

---

<sup>17</sup>Rapistan’s expert, Radcliffe, stated that the Lauzon ‘247 device does not meet this limitation on the ground that it does not have “a glide portion defined by a multiplicity of interconnected wall segments of substantially the same thickness, because it does not have a glide surface.” Radcliffe Tr. 2208:17-22; CDX-27 at 4. However, in so doing, Radcliffe mischaracterized claim 22, which refers to “said support portion” being so defined, not a “glide portion.” As noted earlier, the Lauzon ‘247 device has a “support portion,” and Figure 15 of that patent indicates that its  
(continued...)

of the shoes of the Brouwer '347 patent and the Yu '677 patent do not meet this claim limitation. Radcliffe Tr. 2214:18-2216:19, 2217:9-2219:12; CDX-27 at 5 and 6; RX-333 (Brouwer '347 patent, Fig. 4); RX-602 (Yu '677 patent, Fig. 9); FF 329.

Turning to the question of whether there is “a reason, suggestion, or motivation in the prior art that would lead one of ordinary skill in the art to combine the references and that would also suggest a reasonable likelihood of success,” Smiths Industries, supra, Vanderlande again relies only on the professed “ordinary knowledge of those skilled in the art” in connection with the three references in order to substitute desirable characteristics of either the Yu '677 patent or the Brouwer '347 patent, if any, for missing characteristics of the Lauzon '247 patent in order to come up with five elements of the claims at issue that the Lauzon '247 patent lacks, namely: (i) a slat having a “generally planar” lower wall portion (missing from all three references); (ii) a shoe having “a glide surface surrounding said wall” (missing from Lauzon '247 and Yu '677 but present in Brouwer '347); (iii) “bearing means defining a bearing between at least one of said joining edges of each of said slats and an engaging portion of said glide surface of the corresponding one of said diverter shoes” (missing from all three references); (iv) “means defining lateral stabilizing means” that can “resist[ ] vertical-axis reaction-force-couples” (missing from Lauzon '247 and Yu '677 but present in Brouwer '347); and (v) a diverter shoe having a

---

<sup>17</sup>(...continued)  
walls (item 724) are of equal thickness.



support portion that “is molded of a polymeric material” (missing from Lauzon ‘247 but present in Yu ‘677 and Brouwer ‘347).

Other than molding the support portion of the diverter shoe of a polymeric material as required by claim 20, none of Vanderlande’s reasons persuasively explain or clearly and convincingly demonstrate why a person of ordinary skill in the art would make such substitutions, or why such a person would consider those substitutions to have a reasonable likelihood of success, given the differing basic modes of operation of the systems of the three references and the relative advantages and disadvantages of each.

Turning to the “secondary considerations” element of the obviousness analysis, Rapistan offers the same evidence of commercial success that was offered in connection with the obviousness analysis of claim 1, and that evidence is equally persuasive here.

As with claim 4 discussed above, dependent claims 17, 20 and 22 each carry an independent presumption of validity, and each stands or falls separately from claim 13. Continental Can, *supra*, 948 F.2d at 1266-67. However, a dependent claim is “construed to incorporate by reference all the limitations of the claim to which it refers.” 35 U.S.C. § 112, ¶ 4. Here, some of the elements of claim 13 and the elements of claims 17 and 22 have not been shown to be obvious in view of the combination of the Lauzon ‘247 patent with either the Yu ‘677 or Brouwer ‘347 patents, and claim 20 merely adds an element to claim 13 that, in view of those references, was well known in the art at the time of the invention. Consequently,

taking all elements of claim 13 as incorporated into claims 17, 20 and 22 respectively, those claims have not been shown to be obvious in view of the foregoing references.

Accordingly, for the foregoing reasons, Vanderlande has not demonstrated clearly and convincingly that claims 13, 17, 20 and 22 of the '510 patent are invalid under 35 U.S.C. § 103(a) based on a combination of the Lauzon '247 patent and either the Yu '677 patent or the Brouwer '347 patent.

**K. Are claims 20 and 22 of the '510 patent invalid under 35 U.S.C. § 103(a) based on the Mark 1 Posisorter and either United States Patent No. 4,884,677 or United States Patent No. 4,738,347?**

In view of the foregoing conclusion that the Mark 1 Posisorter is not a relevant prior art reference to claims 20 and 22 of the '510 patent, the contention that those claims are invalid under 35 U.S.C. § 103(a) as obvious in view of a combination of the Mark 1 Posisorter with any other prior art reference must be rejected.

**L. Is claim 23 of the '510 patent invalid under 35 U.S.C. § 102(f) based on the Mark 1 Posisorter?**

In view of the foregoing conclusion that the Mark 1 Posisorter is not a relevant prior art reference to claim 23 of the '510 patent, the contention that claim 23 is invalid under 35 U.S.C. § 102(f) as derived from the Mark 1 Posisorter must be rejected.

**M. Is claim 23 of the '510 patent invalid under 35 U.S.C. § 103(a) based on the Mark 1 Posisorter?**

In view of the foregoing conclusion that the Mark 1 Posisorter is not a relevant prior art reference to claim 23 of the '510 patent, the contention that claim 23 is invalid under 35 U.S.C. § 103(a) based solely on the Mark 1 Posisorter must be rejected.

**N. Are claims 27 and 29 of the '510 patent invalid under 35 U.S.C. § 103(a) based on the Mark 1 Posisorter and either United States Patent No. 4,884,677 or United States Patent No. 4,738,347?**

In view of the foregoing conclusion that the Mark 1 Posisorter is not a relevant prior art reference to claims 27 and 29 of the '510 patent, the contention that those claims are invalid under 35 U.S.C. § 103(a) as obvious in view of a combination of the Mark 1 Posisorter with any other prior art reference must be rejected.

**O. Are claims 23, 27, and 29 of the '510 patent invalid under 35 U.S.C. § 103(a) based on United States Patent No. 3,361,247 and either United States Patent No. 4,884,677 or United States Patent No. 4,738,347?**

Independent claim 23 and dependent claims 27 and 29 recite combinations of elements that appear in claims 13, 17, 20 and 22, which have been found above to be non-obvious under 35 U.S.C. § 103(a) in view of a combination of the Lauzon '247 patent with either the Yu '677 patent or the Brouwer '347 patent. For the same reasons, claims 23, 27 and 29 are non-obvious as well.

**P. Are claims 30 and 33 of the '510 patent invalid under 35 U.S.C. § 102(b) based on United States Patent No. 4,738,347?**

The Brouwer '347 patent has already been discussed as a prior art reference in connection with claims 13, 17, 20, 22, 23, 27 and 29 of the '510 patent. As mentioned earlier herein, the Brouwer '347 patent reference is among the prior art references that were considered by the PTO Examiner during prosecution of the '510 patent at issue. See CX-1 ('510 patent, first page). Consequently, Vanderlande's reliance upon this reference must overcome the presumption that the PTO Examiner properly performed the task of evaluating the validity of the '510 patent in view of this reference. See American Hoist & Derrick, supra.

Vanderlande contends that claims 30 and 33 of the '510 patent are invalid under 35 U.S.C. § 102(b) as anticipated by the Brouwer '347 reference. RIB 122-23. Vanderlande argues the Brouwer '347 reference possesses all of the elements of claims 30 and 33. Id.

Rapistan contends that the Brouwer '347 reference does not anticipate claims 30 and 33 under 35 U.S.C. § 102(b). CRB 128-29. In particular, Rapistan contends, the Brouwer '347 patent fails to disclose a shoe diverting member that includes at least two contiguous surfaces that slope downwardly. Id.

The Staff agrees with Rapistan that the Brouwer '347 reference does not anticipate claims 30 and 33 of the '510 patent. SIB 81. The Staff points out that the Brouwer '347 device lacks a "means defining a glide surface" and "laterally inward" sloping surfaces as those terms are used in claim 30. Id.

As required by 35 U.S.C. § 102(b) for anticipation purposes, the Brouwer '347 patent was issued more than one year prior to the date of the application for the '510 patent in the United States. See 35 U.S.C. § 102(b); RX-333 (Brouwer '347 patent, first page); FF 330. The only element of claims 30 and 33 that the parties dispute as being present in the Brouwer '347 patent is that of "a plurality of contiguous, generally planar surfaces sloping downward from an upper extent of said diverting surface laterally inward and longitudinally forward or rearward."

Vanderlande admits that the diverting shoe of the Brouwer '347 patent has no adjacent surfaces that slope downward and inward. RIB 123; RX-333 (Brouwer '347 patent Figs. 5 and 9); FF 331. Vanderlande only argues that if the claim limitation allows a plurality of adjacent surfaces to include no adjacent surfaces sloping downward and inward, then the Brouwer '347 patent has that limitation. RIB 123. Claim 30 has not been so construed in this Initial Determination. Consequently, Vanderlande's contention is moot.

Accordingly, claims 30 and 33 have not been shown clearly and convincingly to be invalid under 35 U.S.C. § 102(b) as anticipated by the Brouwer '347 patent.

**Q. Is claim 30 of the '510 patent invalid under 35 U.S.C. § 102(f) based on the Mark 1 Posisorter?**

As determined earlier herein, the Mark 1 Posisorter is a prior art reference for purposes of derivation under 35 U.S.C. § 102(f) only with regard to claims 30, 33 and 35 because Rapistan has not adequately demonstrated that Vanderlande's disclosure of that device to Rapistan on March 7, 1990 occurred later than Rapistan's invention of every element of claim 30.

Vanderlande contends that claim 30 of the '510 patent is invalid under 35 U.S.C. § 102(f) as anticipated by the Mark 1 Posisorter. RIB 123-24. Vanderlande argues the Mark 1 Posisorter possesses all of the elements of claim 1. Id.

Rapistan contends that the Mark 1 Posisorter does not anticipate claim 1 under 35 U.S.C. § 102(f). CRB 129-30. In particular, Rapistan contends, the Mark 1 does not disclose a shoe having a diverting member with at least two contiguous, downwardly sloping surfaces. CRB 129.

The Staff argues that the evidence does not support the conclusion that any claims of the '510 patent were derived from materials relating to the Mark 1 Posisorter. SIB 81. The Staff points out that the Mark 1 drawings that were disclosed to Rapistan by Vanderlande on March 7, 1990 do not disclose the entirety of the invention claimed in claim 30 because the Mark 1 lacks, at a minimum, "means defining a glide surface" and a "plurality of contiguous . . . surfaces sloping downward [and] laterally inward" as those terms are used in the '510 patent. SIB 81-82.

Derivation is proven under 35 U.S.C. § 102(f) if it is shown by clear and convincing evidence that the previously conceived concept that was communicated to the inventor of the patent at issue is sufficient to enable a person of ordinary skill in the art, "without the exercise of any ingenuity and special skill on his part, to construct and put the improvement in successful operation." Gambro, supra, 110 F.3d at 1577. The only aspect of the derivation defense that the parties raise as an issue here is whether the Mark 1 Posisorter, as conveyed to Rapistan by Vanderlande on

March 7, 1990, possesses any such concept that lies within the scope of claims 30, 33 and 35.

The Mark 1 Posisorter drawings that were conveyed to Rapistan by Vanderlande on March 7, 1990 suggest nothing about the only element of claim 30 that Rapistan did not conceive before learning of the Mark 1; namely, that of “a plurality of contiguous, generally planar surfaces sloping downward from an upper extent of said diverting surface laterally inward and longitudinally forward or rearward.” Radcliffe Tr. 2219:16-2220:4, 2222:5-2222:12; CDX-27 at 3; RX-30; FF 332. Indeed, Vanderlande admits that the Mark 1 has no adjacent downward and inward sloping surfaces. RIB 123.

As for the remaining elements of claim 30, not only was the Mark 1 conveyed by Vanderlande to Rapistan after Rapistan conceived of those elements on its own, the Mark 1 does not even satisfy those elements. In particular, the Mark 1 Posisorter lacks the element consisting of a “support member having a glide portion including means defining a glide surface adapted to glide along one of said slats,” because the diverter shoe of the Mark 1 Posisorter uses rollers to contact the slat, not a glide surface. Hoet Tr. 2033:11-2034:1; Radcliffe Tr. 2221:17-20; CDX-27 at 3, RX-30; FF 333.

Accordingly, claim 30 has not been shown clearly and convincingly to be invalid under 35 U.S.C. § 102(f) as derived or anticipated by the Mark 1 Posisorter.

**R. Is claim 30 of the ‘510 patent invalid under 35 U.S.C. § 103(a) based on the Mark 1 Posisorter?**

As to whether claim 30 of the '510 patent is invalid under 35 U.S.C. § 103(a) based on the Mark 1 Posisorter, Vanderlande offers no obviousness argument or evidence aside from its contentions concerning anticipation and derivation under 35 U.S.C. § 102(f). RIB 124. Rapistan and the Staff dispute Vanderlande's contention in this regard. CRB 130; SIB 82.

Accordingly, claim 30 has not been shown clearly and convincingly to be invalid under 35 U.S.C. § 103(a) as obvious in view of the Mark 1 Posisorter.

**S. Are claims 30, 33 and 35 of the '510 patent invalid under 35 U.S.C. § 103(a) based on United States Patent No. 3,361,247 and United States Patent No. 4,884,677?**

The only element of claims 30, 33 and 35 of the '510 patent that has not been discussed earlier herein in connection with obviousness under 35 U.S.C. § 103(a) in view of the Lauzon '247 and Yu '677 patents is the element of "a diverting member joined to said support member and having at least one substantially vertical diverting surface on a lateral end thereof and a plurality of contiguous, generally planar surfaces sloping downward from an upper extent of said diverting surface laterally inward and longitudinally forward or rearward." Vanderlande admits that the Yu '677 patent does not disclose adjacent surfaces that slope downward and inward. RIB 124. Vanderlande only argues that if the claim limitation allows a plurality of adjacent surfaces to include no adjacent surfaces sloping downward and inward, then the Yu '677 patent has that limitation. RIB 124. Rapistan and the Staff oppose Vanderlande's contentions. CRB 131-33; SIB 82.



Claim 30 has not been so construed in this Initial Determination. Consequently, Vanderlande's contention is moot. Accordingly, claims 30, 33 and 35 have not been shown clearly and convincingly to be invalid under 35 U.S.C. § 103(a) as obvious in view of the Lauzon '247 and Yu '677 patents.

**T. Are claims 33 and 35 of the '510 patent invalid under 35 U.S.C. § 103(a) based on the Mark 1 Posisorter and either United States Patent No. 4,884,677 or United States Patent No. 4,738,347?**

In connection with the element in dependent claim 33 "wherein said support member guide portion is molded of a polymeric material," the Yu '677 device includes a molded polymer body base, as already discussed herein. The Brouwer '347 patent also has a plastic diverter shoe, as already discussed herein. Also, it has already been shown with relation to these references that plastics were well-known and used in the sortation industry at the time of the invention of the '510 patent, and a person of ordinary skill would have been motivated to use plastics to make a diverter shoe. Accordingly, a person of ordinary skill in the art would have been motivated to mold the diverter shoes of the Mark 1 Posisorter of a polymeric material.

In connection with the element in dependent claim 35 "wherein said glide portion is defined by a multiplicity of interconnected wall segments having substantially the same thickness," as already discussed herein, the support portions of the shoes of the Brouwer '347 patent and the Yu '677 patent do not meet this claim limitation. Vanderlande argues, however, that the Mark 1 Posisorter has wall segments having substantially the same thickness. RIB 125-26.

Rapistan and the Staff dispute Vanderlande's contentions in this regard. CRB 133-34; SIB 83. Having failed to demonstrate how claim 30, from which claims 33 and 35 ultimately depend, is obvious in light of the foregoing references, Vanderlande has also failed to show how the additional limitations of claims 33 and 35 are obvious.

Accordingly, claims 33 and 35 have not been shown clearly and convincingly to be invalid under 35 U.S.C. § 103(a) as obvious in view of the Mark 1 Posisorter and either the Brouwer '347 or Yu '677 patents.

**U. Is claim 42 of the '510 patent invalid under 35 U.S.C. § 102(f) based on the Mark 1 Posisorter?**

In view of the foregoing conclusion that the Mark 1 Posisorter is not a relevant prior art reference to claim 42 of the '510 patent, the contention that claim 42 is invalid under 35 U.S.C. § 102(f) as derived from the Mark 1 Posisorter must be rejected.

**V. Are claims 42, 43, and 45 of the '510 patent invalid under 35 U.S.C. § 103(a) based on the Mark 1 Posisorter?**

In view of the foregoing conclusion that the Mark 1 Posisorter is not a relevant prior art reference to claims 42, 43 and 45 of the '510 patent, the contention that those claims are invalid under 35 U.S.C. § 103(a) based solely on the Mark 1 Posisorter must be rejected.

**W. Are claims 42, 43, and 45 of the '510 patent invalid under 35 U.S.C. § 103(a) based on United States Patent No. 3,361,247 and United States Patent No. 4,884,677?**

Vanderlande contends that claims 42, 43 and 45 of the '510 patent are invalid under 35 U.S.C. § 103(a) as obvious based on the Lauzon '247 patent and the Yu '677 patent. RIB 127-28. Rapistan and the Staff dispute these contentions. CRB 136-37; SIB 84. As previously discussed herein in connection with claims 1 and 30, neither the Lauzon '247 nor Yu '677 patent references have the element of claim 42 consisting of "a support member having a glide portion including means defining a glide surface adapted to glide along one of said slats." As this element is common to all three claims 42, 43 and 45, Vanderlande therefore has failed to demonstrate clearly and convincingly that claims 42, 43 and 45 are obvious under 35 U.S.C. § 103(a) in light of the Lauzon '247 and Yu '677 references.

- X. Are claims 1, 4, 13, 17, 20, 22, 23, 27, 29, 30, 33, 35, 42, 43, and 45 of the '510 patent invalid under 35 U.S.C. §§ 101, 102(f), and/or 112 for claiming a glide surface broader than the glide surface "invented" by the applicants?**

According to Vanderlande, all of the asserted claims of the '510 patent are invalid under 35 U.S.C. §§ 101, 102(f), and/or 112 for claiming a glide surface that is broader than the glide surface invented by the named inventors of the patent. RIB 99-103; RRB 75-77. According to Vanderlande, the inventors of the '510 patent conceded that they had never thought of an embodiment of their invention that did not have a diverter shoe in contact with the conveying surface of the slat. RIB 101-02; RRB 76. From this alleged concession, Vanderlande argues that the "glide surface" limitations of the foregoing claims are overbroad because they improperly encompass diverter shoes that do not contact the conveying surface of the slat, as is the case with the Mark 2 Posisorter. RIB 103.

Rapistan disputes Vanderlande's contention. CIB 147-48; CRB 88-95. According to Rapistan, these contentions misunderstand fundamental tenets of patent law. CRB 88. The invention is defined by the claims, Rapistan contends, and the invention may be broader than the embodiment disclosed in the patent. *Id.* In this case, according to Rapistan, contact between the glide surface and the upper slat wall is not a requisite part of the claimed invention. CRB 89. Further, Rapistan maintains, inventor testimony is inappropriate to use in assessing the validity of claims under 35 U.S.C. § 112, ¶ 2. CRB 91-92.

The Staff also disagrees with Vanderlande. SIB 84; SRB 27-28. According to the Staff, Vanderlande fails to recite a specific legally-recognized ground for invalidating a patent. SIB 84. The Staff also maintains that Vanderlande's argument leads to the faulty conclusion that any modification or improvement to a claimed invention that was not "thought of" by the inventors necessarily falls outside the coverage of the claim. SRB 28. Contrary to this argument, the Staff contends, a claim containing limitations A, B, and C can be infringed by a device having A, B, C, and D, even if D was not part of the inventor's conception of the invention. *Id.*

Vanderlande's contention is premised on inventor statements. At trial, David Cotter testified as follows:

Q Now, every design that you worked on had contact on the top conveying surface; correct?

A That's correct.

Q And you never considered any design that didn't contact the top conveying surface; correct?

A That is correct.

Cotter Tr. 660:5-10; FF 334.

Similarly, at his deposition, Bernard Woltjer testified as follows:

Q Before filing this patent, did you think of any variation of your invention which did not have a glide surface that had contact on the top?

A No.

JX-24C (Woltjer Dep. 176:13-16); FF 335. At trial, Woltjer testified somewhat differently as follows:

Q And during that entire effort over that year, you never considered any variation of your invention that did not have a glide surface which contacted the top of the slat; correct?

A I don't know that we didn't, but it's not in the record. So what we have is what we have.

Q There's no record of you considering any other design other than one that had contact on the top of the conveying surface?

A Right. I didn't keep all the napkins from the cafeteria, so I don't know exactly all the possibilities we covered, but this is the evidence.

Woltjer Tr. 441:21-442:7; FF 336. The third inventor, Curtis LeMay, was involved with the design of the diverting member, not the support member or the glide surface of the support member. JX-8C (LeMay Dep. 16:6-17:12, 22:16-23:1, 30:14-18, 71:5-8); FF 337.

What Vanderlande essentially contends is that there is an "element" of all asserted claims of the '510 patent that requires the glide surface to have "contact on the top conveying surface." In construing the claims, however, this "element" has not been found to exist in any of them. Vanderlande cannot read such a straw-man

“element” into the claims and then go hunting for prior art that includes this “element,” touting the ‘510 patent claims’ invalidity as a result. By the same token, Vanderlande cannot aver that the Mark 2 Posisorter does not infringe any claim of the ‘510 patent because it does not have this imaginary “element.” In analyzing invalidity and infringement, one is limited to what is claimed, and other features of the prior art, the disclosed embodiment and the accused product are irrelevant.

An inventor does not have to conceive of every possible embodiment of the claimed invention in order to secure a patent. As the Federal Circuit has held:

The law does not require the impossible. Hence, it does not require that an applicant describe in his specification every conceivable and possible future embodiment of his invention. The law recognizes that patent specifications are written for those skilled in the art, and requires only that the inventor describe the “best mode” known at the time to him of making and using the invention.

SRI Intern. v. Matsushita Elec. Corp. of America, 775 F.2d 1107, 1121 (Fed.Cir. 1985); accord, Lockwood v. American Airlines, Inc., 107 F.3d 1565, 1572 (Fed.Cir. 1997) (“It is not sufficient for purposes of the written description requirement of § 112 that the disclosure, when combined with the knowledge in the art, would lead one to speculate as to modifications that the inventor might have envisioned, but failed to disclose. Each application in the chain [of patent prosecution] must describe the claimed features.”). Further, it is the claims, not the features of the preferred embodiment or of any accused device, that define the scope of the invention; in the words of the Federal Circuit, “the name of the game is the claim.” See In re Hiniker Co., 150 F.3d 1362, 1368-69 (Fed.Cir. 1998). Moreover, the testimony of a patent’s inventor does not govern the scope of the claims. See Solomon v. Kimberly-Clark

Corp., 216 F.3d 1372, 1379-80 (Fed.Cir. 2000) (“It is particularly inappropriate to consider inventor testimony obtained in the context of litigation in assessing validity under section 112, paragraph 2, in view of the absence of probative value of such testimony . . . it is not unusual for there to be a significant difference between what an inventor thinks his patented invention is and what the ultimate scope of the claims is after allowance by the PTO.”).

The cases cited by Vanderlande do not support its position on this issue.<sup>18</sup> The seminal case of Graver Tank & Mfg. Co. v. Linde Air Products Co., 336 U.S. 271, 276-77 (1949) (“Graver Tank”), is particularly instructive in this regard. In Graver Tank, the District Court decided to invalidate patent claims as overbroad, reasoning that the claims comprehended more than the invention because the claim terms “silicates” and “metallic silicates” encompassed more than the nine specified metallic silicates that had been proved to be operative. Id. at 276. The Court of Appeals reversed, holding that there was nothing in the record to show that the applicants for the patent intended by these claims to assert a monopoly broader than the nine metallic silicates named in the specifications, and therefore the claims should have been construed narrowly as so limited by the specifications. Id. at 276-77.

---

<sup>18</sup>Vanderlande cites University of Colorado Foundation, Inc. v. American Cyanamid Co., 105 F.Supp.2d 1164, 1175 (D.Colo. 2000) for the proposition that “[b]ecause patents reward the inventors for disclosing new technology to the public, only a true inventor is entitled to a patent.” RIB 100; RRB 76. Other than stating this general proposition of patent law, the case has to do with inventorship, not overbroad claiming, and has no further relevance to the issue at hand.

The Supreme Court sided with the District Court, ruling as follows:

We have frequently held that it is the claim which measures the grant to the patentee. [citations omitted] While the cases more often have dealt with efforts to resort to specifications to expand claims, it is clear that the latter fail equally to perform their function as a measure of the grant when they overclaim the invention. When they do so to the point of invalidity and are free from ambiguity which might justify resort to the specifications, we agree with the District Court that they are not to be saved because the latter are less inclusive. [citations omitted].

Graver Tank, *supra*, 336 U.S. at 277 (emphasis added). The underscored language identifies where Graver Tank departs from Vanderlande's rationale. According to Graver Tank, the claims measure the scope of the patent grant, but when they claim too broadly as written, (as, for example, when they ensnare prior art), they are invalid even if they could be interpreted by resort to the specification to be no broader than the narrow preferred embodiment. Here, by contrast, the asserted claims of the '510 patent are silent about a feature of the preferred embodiment that falls beyond the claims as written – namely, that the glide surface of the diverter shoe of the preferred embodiment has contact on the top conveying surface of the slat. Thus, Graver Tank has no impact on principle applicable here that “[t]he written description part of the specification itself does not delimit the right to exclude. That is the function and purpose of claims.” Markman v. Westview Instruments, Inc., 52 F.3d 967, 980 (Fed.Cir. 1995), *aff'd*, 517 U.S. 370 (1996).

Gentry Gallery, Inc. v. Berkline Corp., 134 F.3d 1473, 1479 (Fed.Cir. 1998) (“Gentry Gallery”) does not compel a different conclusion. In Gentry Gallery, the Federal Circuit found a claim to be invalid as overbroad, but noted its difference



from the prior case of Ethicon Endo-Surgery, Inc. v. United States Surgical Corp., 93

F.3d 1572, 1582 n. 7 (Fed.Cir.1996) (“Ethicon I”), which is relevant here:

Gentry’s reliance on Ethicon II is misplaced. It is true, as Gentry observes, that we noted that “an applicant . . . is generally allowed claims, when the art permits, which cover more than the specific embodiment shown.” Ethicon II, 93 F.3d at 1582 n. 7, 40 U.S.P.Q.2d at 1027 n. 7 . . . . However, we were also careful to point out in that opinion that the applicant “was free to draft claim[s] broadly (within the limits imposed by the prior art) to exclude the lockout’s exact location as a limitation of the claimed invention” only because he “did not consider the precise location of the lockout to be an element of his invention.” Id. Here, as indicated above, it is clear that Sproule considered the location of the recliner controls on the console to be an essential element of his invention. Accordingly, his original disclosure serves to limit the permissible breadth of his later-drafted claims.

Gentry Gallery, supra (emphasis added). Here, as in Ethicon I, there is no evidence suggesting that a glide surface having contact on the top conveying surface is an essential element of the invention of the ‘510 patent, much less any element of any claim at all. Thus, Gentry Gallery does not govern this case.

The same is true of Tronzo v. Biomet, Inc., 156 F.3d 1154, 1158-59 (Fed.Cir. 1998) (“Tronzo”), in which the Federal Circuit determined in the case of a patent for an artificial hip prosthesis, including a cup implant for a hip socket, that the patent’s specification described only a conical cup shape, and therefore did not provide sufficient support for claims that were generic as to the shape of the cup. Id. In Tronzo, the Federal Circuit found that a reading of the specification disclosed only the conical cup shape and no other, and that the specification’s only reference to a different shape was a recitation of the prior art. Id. That recitation, the Court further found, specifically distinguished the prior art as inferior and touted the advantages

of the conical shape of the cup of the patented invention. *Id.* “Such statements make clear,” the Federal Circuit held, “that the ‘589 patent discloses only conical shaped cups and nothing broader.” *Id.* Again, the claim at issue in Tronzo was held invalid for what it explicitly covered improperly, not for what it was silent about.

In short, Vanderlande fails to demonstrate, clearly and convincingly, that claims 1, 4, 13, 17, 20, 22, 23, 27, 29, 30, 33, 35, 42, 43, and 45 of the ‘510 patent are invalid under 35 U.S.C. §§ 101, 102(f), and/or 112 for claiming a glide surface broader than the glide surface invented by the applicants.

**Y. Are claims 1, 4, 13, 17, 20, 22, 23, 27, 29, 30, 33, 35, 42, 43, and 45 of the ‘510 patent invalid under 35 U.S.C. § 112 for not disclosing the structure that corresponds to the “track means?”**

According to Vanderlande, if the specification of the ‘510 patent does not provide a sufficient description of the “track means” limitation of the asserted claims of the ‘510 patent, then it is invalid under 35 U.S.C. § 112, ¶ 2 for being indefinite. RIB 103-04; RRB 77-79. Rapistan and the Staff dispute this contention. CIB 148-49; CRB 96-97; SIB 85. As explained herein in connection with the construction of the “track means” claim limitation, the ‘510 patent specification discloses sufficient structure to be understood by one skilled in the art to be adequate to perform the recited functions. See Budde v. Harley-Davidson, Inc., 250 F.3d 1369, 1376-77 (Fed.Cir. 2001).

Accordingly, Vanderlande has failed to demonstrate clearly and convincingly that claims 1, 4, 13, 17, 20, 22, 23, 27, 29, 30, 33, 35, 42, 43, and 45 of the ‘510

patent are invalid under 35 U.S.C. § 112 for not disclosing the structure that corresponds to the “track means” element of the asserted claims.

## VIII. Other Defenses

### A. License/Co-ownership

#### 1. Relevant Law

##### a. Inventorship

The patent statute provides that when an invention is made by two or more persons, they shall apply for the patent jointly. 35 U.S.C. § 116; also see Certain EPROM, EEPROM, Flash Memory, and Flash Microcontroller Semiconductor Devices, and Products Containing Same, Inv. No. 337-TA-395, USITC Pub. No. 3136, Commission Opinion at 7 (October 1998) (“EPROM”). Where there is joint inventorship, the patent must issue to all inventors. 35 U.S.C. §§ 102(f), 116, and 256.

The issuance of a patent creates a presumption that the named inventors are the true and only inventors. Ethicon, Inc. v. United States Surgical Corp., 135 F.3d 1456, 1460 (Fed.Cir.), cert. denied, 525 U.S. 923 (1998) (“Ethicon II”). “In order to rebut this presumption, a party challenging patent validity for omission of an inventor must present clear and convincing evidence that the omitted individual actually invented the claimed invention.” See Acromed Corp. v. Sofamor Danek Group, Inc., 253 F.3d 1371, 1379 (Fed.Cir. 2001). Inventorship is a question of law. Ethicon II, supra.

“Conception is the touchstone of inventorship.” Burroughs Wellcome Co. v. Barr Laboratories, Inc., 40 F.3d 1223, 1227 (Fed.Cir. 1994), cert. denied, 516 U.S. 1070 (1996). It is the “formation in the mind of the inventor, of a definite and permanent idea of the complete and operative invention as it is hereafter to be applied in practice.” Hybritech, Inc. v. Monoclonal Antibodies, Inc., 802 F.2d 1367, 1376 (Fed.Cir. 1986) (“Hybritech”). “An idea is sufficiently ‘definite and permanent’ when ‘only ordinary skill would be necessary to reduce the invention to practice, without extensive research or experimentation.’” Ethicon II, supra, 135 F.3d at 1460. “The conceived invention must include every feature of the subject matter claimed in the patent.” Id. Moreover, in the case of patent claims having means-plus-function language, “the contributor of any disclosed means of a means-plus-function claim element is a joint inventor as to that claim, unless one asserting sole inventorship can show that the contribution of that means was simply a reduction to practice of the sole inventor’s broader concept.” Ethicon II, supra, 135 F.3d at 1463; quoted in EPROM, supra.

To be a joint inventor, “an individual must make a contribution to the conception of the claimed invention that is not insignificant in quality, when that contribution is measured against the dimension of the full invention.” Fina Oil & Chemical Co. v. Ewen, 123 F.3d 1466, 1473 (Fed.Cir. 1997) (“Fina”). However, each of the joint inventors does not have to make the same type or amount of contribution to the invention; each needs to perform only a part of the task which produces the invention. Ethicon II, supra. Further, a co-inventor need not make a

contribution to every claim of a patent; a contribution to one claim is enough. Id.  
“Thus, the critical question for joint conception is who conceived, as that term is  
used in the patent law, the subject matter of the claims at issue.” Id.

A person does not qualify as a joint inventor by merely assisting the actual  
inventor after conception of the claimed invention. Ethicon II, supra. “One who  
simply provides the inventor with well-known principles or explains the state of the  
art without ever having ‘a firm and definite idea’ of the claimed combination as a  
whole does not qualify as a joint inventor.” Id.

In order to be considered a joint inventor, there must be clear and convincing  
evidence corroborating the individual’s contribution. Fina, supra, 123 F.3d at 1474.

In Ethicon II, the Federal Circuit noted in this regard that:

an inventor’s testimony respecting the facts surrounding a  
claim of derivation or priority of invention cannot, standing  
alone, rise to the level of clear and convincing proof. Price v.  
Symsek, 988 F.2d 1187, 1194, 26 USPQ2d 1031, 1036  
(Fcd.Cir. 1993). The rule is the same for an alleged  
co-inventor’s testimony. See Hess, 106 F.3d at 980. Thus, an  
alleged co-inventor must supply evidence to corroborate his  
testimony. See Price, 988 F.2d at 1194. Whether the  
inventor’s testimony has been sufficiently corroborated is  
evaluated under a “rule of reason” analysis. Id. at 1195.  
Under this analysis, “[a]n evaluation of all pertinent evidence  
must be made so that a sound determination of the credibility  
of the [alleged] inventor’s story may be reached.” Id.

Corroborating evidence may take many forms. Often  
contemporaneous documents prepared by a putative inventor  
serve to corroborate an inventor’s testimony. See id. at  
1195-96. Circumstantial evidence about the inventive process  
may also corroborate. See Knorr v. Pearson, 671 F.2d 1368,  
1373, 213 USPQ 196, 200 (CCPA 1982) (“[S]ufficient  
circumstantial evidence of an independent nature can satisfy  
the corroboration rule.”) Additionally, oral testimony of

someone other than the alleged inventor may corroborate. See Price, 988 F.2d at 1195-96.

Ethicon II, supra, 135 F.3d at 1461; quoted in EPROM, Initial Determination at 97-98 (March 19, 1998, Pub. vers. April 29, 1998).

b. **Ownership and License**

“Questions of patent ownership are distinct from questions of inventorship.” Ethicon II, supra, 135 F.3d at 1465. In the context of joint inventorship, “each co-inventor presumptively owns a pro rata undivided interest in the entire patent, no matter what their respective contributions.” Id. Thus, a joint inventor as to even one claim enjoys a presumption of ownership in the entire patent. Id. at 1466. Such a co-inventor might thus acquire ownership in a patent with dozens of claims. See id. Under such circumstances, “where inventors choose to cooperate in the inventive process, their joint inventions may become joint property without some express agreement to the contrary.” Id.

As such, all co-owners (or, in the alternative, the exclusive licensee of each co-owner) must join as plaintiffs under any action for infringement of the patent. Ethicon II, supra, 135 F.3d at 1468; accord, International Nutrition Co. v. Horphag Research Ltd., 257 F.3d 1324, 1331 (Fed.Cir. 2001) (“International Nutrition”). “One co-owner has the right to impede the other co-owner’s ability to sue infringers by refusing to voluntarily join in such a suit.” International Nutrition, supra; Schering Corp. v. Roussel-UCLAF S.A., 104 F.3d 341, 345 (Fed.Cir.1997). Nevertheless, “if, by agreement, a co-owner waives his right to refuse to join a suit, his co-owners may

subsequently force him to join in a suit.” International Nutrition, supra; Ethicon II, supra, 135 F.3d at n. 9.

If nonjoinder of an actual inventor is proved by clear and convincing evidence, the patent is rendered invalid. See Pannu v. Iolab Corp., 155 F.3d 1344, 1349 (Fed.Cir. 1998). In the absence of deceptive intent, the invalidity may be overcome by naming the non-joined inventor as an inventor of the patent by court order or by application to the PTO, in accordance with the procedures set forth in 35 U.S.C. § 256. Stark v. Advanced Magnetics, Inc., 119 F.3d 1551, 1555 (Fed.Cir. 1997). The U.S. International Trade Commission, however, has no power in Section 337 investigations to correct inventorship. EPRON, supra at 9. Consequently, the failure to add a joint inventor renders a patent “unenforceable, at least temporarily” for purposes of Section 337 “unless and until either the PTO or a court makes the correction.” Id.

**2. Is either Jacobus van den Goor and/or Ton van der Wielen an omitted inventor of the invention claimed in the ‘510 patent?**

Vanderlande argues that if Rapistan’s “overly broad interpretation” of the claim term “glide surface” is adopted (that is, an interpretation that does not require contact between the glide surface and the upper surface of the slat), then Jacobus van den Goor is an unnamed co-inventor of the ‘510 patent by reason of the Mark 1 Posisorter drawings that he showed to Rapistan employees on March 7, 1990. RIB 130; RRB 87. Further, Vanderlande argues, if Rapistan’s interpretation of the claim term “a diverting member . . . having at least one substantially vertical diverting

surface on a lateral end thereof and a plurality of contiguous, generally planar surfaces sloping downward from an upper extent of said diverting surface laterally inward and longitudinally forward or rearward” is adopted, and if it is found that this term covers the Mark 2 Posisorter, then Ton van der Wielen is an unnamed co-inventor of the ‘510 patent as well by reason of a memorandum that he prepared and gave to Rapistan in November 1989. RIB 130-31; RRB 87-88.

Rapistan disputes that either van den Goor or van der Wielen are co-inventors of the ‘510 patent. CIB 149-52; CRB 138-43. Rapistan argues that neither van den Goor nor van der Wielen contributed anything to the inventions disclosed and claimed in the ‘510 patent. CIB 151. Indeed, Rapistan contends, van den Goor and Vanderlande’s former president, Rein van der Lande, admitted that van den Goor was not a co-inventor. CIB 151; CRB 138.

The Staff agrees with Rapistan that neither van den Goor nor van der Wielen are co-inventors of the ‘510 patent. SIB 86. There is no evidence, the Staff submits, that Vanderlande personnel had any involvement in the development of the RS-200. SIB 86.

The interpretation of the claim term “glide surface” adopted by this Initial Determination does not require contact between the glide surface and the upper surface of the slat. Moreover, the interpretation of the claim term “a diverting member . . . having at least one substantially vertical diverting surface on a lateral end thereof and a plurality of contiguous, generally planar surfaces sloping downward from an upper extent of said diverting surface laterally inward and longitudinally



forward or rearward” adopted by this Initial Determination covers the Mark 2 Posisorter. Accordingly, Vanderlande’s co-inventorship arguments are not moot.

At trial, van den Goor admitted that he is not a co-inventor of the ‘510 patent. Van den Goor Tr. 1736:22-1737:9; FF 338. Rein van der Lande, Vanderlande’s former president, agreed with that assessment. Van der Lande Tr. 1675:5-14; FF 339. Accordingly, by the purported co-inventor’s own admission under oath and in the presence of Vanderlande’s trial counsel, Jacobus van den Goor is not a co-inventor of the ‘510 patent.

As for van der Wielen, the relevant facts are as follows. [

] JX-19C (van der Wielen Dep. 71:23-72:3); FF 342. In November 1989, Bernard Woltjer visited Vanderlande at its headquarters in Veghel, The Netherlands.

---

<sup>19</sup>The record contains two versions of the November 8, 1989 van der Wielen memo, CX-154C and CX-511C. CX-511C is a copy of the memo that Woltjer received from van den Goor at the November 8, 1989 meeting at Veghel. CX-154C is a copy of the memo that Vanderlande retained in its possession. There are some differences between the Vanderlande and Rapistan copies of the November 8 memo. Specifically, the Rapistan version does not contain a so-called lead line in the upper right hand drawing on page 2 of the memo. Compare CX-154C (Vanderlande version) with CX-511C (Rapistan version). Since the issue at hand concerns what, if anything, that Vanderlande conveyed to Rapistan about the concepts in this memo, further references shall be to CX-511C unless otherwise noted.

Woltjer Tr. 369:12-370:2; FF 343. He met with van den Goor on November 8, 1989, and at that meeting Woltjer received a copy of the van der Wielen memorandum. JX-24C (Woltjer Dep. 55:19-24); Woltjer Tr. 376:23-377:12; CX-511C; FF 344.

In one of the questions of the November 8 memo, van der Wielen memo asked Rapistan for an opinion about two proposed shoe shapes. CX-511C. Underneath that question are four drawings of top and side views of the proposed shapes that van der Wielen drew on the memo. JX-19C (van der Wielen Dep. 60:6-61:2); CX-511C. They appear as follows:

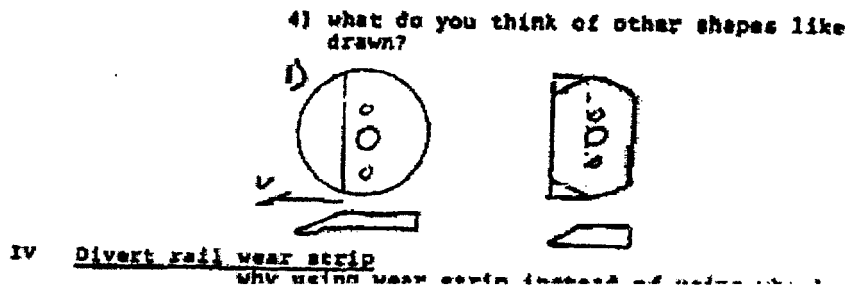

CX-511C; FF 345.

At his deposition, van der Wielen was asked to explain what he was trying to depict in the drawing on the right hand side. His relevant testimony is as follows:

[

]

JX-19C (van der Wielen Dep. 64:2-13); FF 346. Van der Wielen further testified at his deposition as follows:

[

]

JX-19C (van der Wielen Dep. 122:11-123:2, 123:11-21); FF 347.

[

] These two slopes of the Mark 2 shoe are the same surfaces that have been identified by Rapistan as corresponding to surfaces 82c and 82j of the preferred embodiment of the '510 patent, thereby satisfying the requirement in claim 30 of the patent for "contiguous, generally planar surfaces sloping downward from an upper extent of said diverting surface laterally inward and longitudinally forward or rearward."

Woltjer prepared a written response to van der Wielen's memo. Woltjer Tr. 380:23-381:12; RX-430C; FF 349. In response to the question about the two proposed shoe shapes, Woltjer's written reply stated as follows:

When the shoe first impacts the product it will over rotate and the rear corner will become caught in any gap between the shoes, so at the end of the divert angle where it goes straight, it gives the corner of these cartons a flick which spins them a little. The best shapes [sic] shoe would provide a continuous surface when several are pushing product.

RX-430C; FF 350. At trial, Woltjer explained his response as follows:

Well, in responding to that question, "what do you think of shapes like that," in this business you really cannot tell a lot unless you have experience doing it or you observed it or you test it, and not having tested that sort of thing I kind of responded in a generic way and kind of gave them guidelines for how a design ought to be made, as opposed to a direct answer to whether of those two shapes, would be one better than the other or one more appropriate than the other.

Woltjer Tr. 383:4-12; FF 351.

When Woltjer returned to Rapistan from his trip to Vanderlande in The Netherlands, he shared with others at Rapistan the information that he learned from Vanderlande. Woltjer Tr. 431:9-15; JX-24C (Woltjer Dep. 80:3-7); **FF 352**. Those with whom he shared such information probably included the other inventors of the '510 patent, Cotter and LeMay. Woltjer Tr. 431:16-21; JX-24C (Woltjer Dep. 80:21-81:3); **FF 353**. There is no evidence in the record, however, that Woltjer showed or discussed the November 8, 1989 van der Wielen memo to anyone at Rapistan.

Curtis LeMay is credited with designing the shape of the sloping surfaces of the top of the diverter shoe of the '510 patent. Cotter Tr. 522:14-23; **FF 354**. According to LeMay's deposition testimony, Cotter told LeMay in the fall of 1989 to work on that design, and of the need for the shoe top to be able to relieve jams that could happen on a sorter. JX-8C (LeMay Dep. 17:3-12); **FF 355**. According to LeMay, Cotter gave two suggestions on the design: "that it was the direction and movement of the sorter shoe relative to the cartons that were being conveyed;" and that, to be safe, the backside of the shoe should be tapered in addition to the front side "just in case there was some kind of strange happenstance from where the sorter jammed from behind rather than from ahead." JX-8C (LeMay Dep. 18:6-17); **FF 356**.

In order to design the shape of the shoe top, LeMay made clay models of proposed shapes with the objective of minimizing the slope of the faces on the shoe, thereby minimizing the potential for jamming. JX-8C (LeMay Dep. 19:11-20:3); **FF 357**. According to LeMay, Cotter suggested minimizing the slopes as a result of Woltjer's request that the shoe cap should alleviate any jamming. JX-8C (LeMay

Dep. 46:17-18:7); **FF 358**. The clay model shapes were input into a 3-dimensional computer-aided design unit, or "CAD." JX-8C (LeMay Dep. 20:4-7); **FF 359**. A "production intent" drawing was generated by the CAD having a date of March 17, 1990. JX-8C (LeMay Dep. 50:4-19); RX-337C; **FF 360**. LeMay testified that, other than his memory, he had no other way to show when he completed his work on the shoe top. JX-8C (LeMay Dep. 51:12-18); **FF 361**.

In a document dated July 26, 1989, Rapistan created a "preliminary design specification" for a "high rate sorter" that eventually became the RS200 sortation system. Woltjer Tr. 341:24-342:8; CX-308C; **FF 362**. In that specification, one of Rapistan's stated objectives was that the design should be "contoured to prevent 'pinch' type jams." Woltjer Tr. 342:9-22; CX-308C; **FF 363**. Thus, Rapistan focused on solving the jamming problem that the contour of the shoe top surface addresses in the '510 patent well before van der Wielen raised his questions in the November 8, 1989 memo and well before Woltjer received that memo during his trip to Vanderlande that same month.

There is no connection in the record whatsoever between van der Wielen's memo and LeMay's work at Rapistan that resulted in the final design for the shoe top that eventually became the preferred embodiment of the '510 patent. There is no evidence of record that LeMay, in creating his design for the shoe top, had a copy of the van der Wielen memo, discussed the van der Wielen memo with anyone, or was made aware of its contents by anyone in any other way. By the drafter's own admission, the van der Wielen memo does not convey in and of itself the notion of

---

angled, sloped surface like surfaces 82c and 82j of the preferred embodiment of the '510 patent, and there is no evidence of record that van der Wielen ever conveyed to Woltjer or anyone else that it did convey such a notion. Although van der Wielen testified at his deposition that the sloped surfaces shown in the drawing in the November 8 memo correspond to the sloped surfaces of the Mark 2 Posisorter that are accused of meeting the "laterally inward and longitudinally forward or rearward" surface element of claim 30 of the '510 patent, the surfaces shown in the memo do not duplicate the surfaces on the Mark 2 Posisorter.

The fact that van der Wielen conceived of a design feature that later evolved into part of the allegedly infringing design of the Mark 2 Posisorter does not, without more, translate into the notion that van der Wielen is a co-inventor of the '510 patent. "[F]or the conception of a joint invention, each of the joint inventors need not 'make the same type or amount of contribution' to the invention." Ethicon II, supra, 135 F.3d at 1460. However, each joint inventor has to perform "a part of the task which produces the invention." Id. There is no evidence of record that van der Wielen took any part in the task that produced the invention of the '510 patent.

Accordingly, Vanderlande has failed to demonstrate that either Jacobus van den Goor or Ton van der Wielen is an omitted inventor of the invention claimed in the '510 patent.

**3. If Jacobus van den Goor is an omitted inventor of the '510 patent, are Respondents co-owners of the '510 patent?**

As determined above, Jacobus van den Goor is not an omitted inventor of the '510 patent, and therefore Vanderlande is not a co-owner of the '510 patent.

**4. If Ton van der Wielen is an omitted inventor of the '510 patent, are Respondents co-owners of the '510 patent?**

As determined above, Ton van der Wielen is not an omitted inventor of the '510 patent, and therefore Vanderlande is not a co-owner of the '510 patent.

**5. Is UPS licensed under the '510 patent?**

**6. If UPS is licensed in Louisville under the '510 patent, is there any infringement?**

Vanderlande has omitted from its pre-hearing brief and post-hearing briefs all argument on the above-referenced issues of licensure and infringement on the part of UPS under the '510 patent. Accordingly, these issues are deemed to be waived and need not be adjudicated. See Order No. 2, Ground Rules 10 and 20 (August 8, 2001).

**B. Estoppel**

**1. Relevant Law**

In order to bar a patentee's infringement action by the defense of equitable estoppel, the alleged infringer must establish three elements:

1) the patentee, through misleading conduct, leads the alleged infringer to reasonably infer that the patentee does not intend to enforce its patent against the alleged infringer, 2) the alleged infringer relies on that conduct, and 3) due to its reliance, the alleged infringer will be materially prejudiced if the patentee is allowed to proceed with its claim.



Ecolab, Inc. v. Envirochem, Inc., 264 F.3d 1358, 1371 (Fed.Cir. 2001) (“Ecolab”); A.C. Aukerman Co. v. R.L. Chaides Construction Co., 960 F.2d 1020, 1041-43 (Fed.Cir. 1992 (*en banc*) (“Aukerman”). “Unlike laches, which focuses on the reasonableness of the [patentholder’s] behavior, estoppel focuses on what the [alleged infringer] has been led to reasonably believe from the [patentholder’s] conduct.” ABB Robotics, Inc. v. GMFanuc Robotics Corp., 828 F.Supp. 1386, 1397 (E.D. Wisc. 1993), *aff’d*, 52 F.3d 1062 (Fed.Cir. 1995) (“ABB”).<sup>20</sup> Moreover, “[u]nlike laches, equitable estoppel does not require the passage of an unreasonable period of time in filing suit.” Aukerman, supra, 960 F.2d at 1042.

The first estoppel element usually involves conduct by the patentee consisting of either an affirmative act, or inaction, that suggests to the alleged infringer that an infringement claim will not be made against it. See Aukerman, supra, 960 F.2d at 1042. The second element requires that the defendant “substantially relied on the misleading conduct of the patentee in connection with taking some action.” *Id.* The third element requires a showing of prejudice if the suit is allowed to go forward, typically by reason of a change of economic position by the alleged infringer during the period of delay. See, e.g., ABB Robotics, Inc. v. GMFanuc Robotics Corp., 52 F.3d 1062, 1065 (Fed.Cir. 1995).

---

<sup>20</sup>The defense of laches, which only affects the amount of damages and does not apply to prospective relief of an injunctive nature such as the remedies available under Section 337, is not recognized by the Commission as a defense under Section 337. Certain Personal Watercraft and Components Thereof, Inv. No. 337-TA-452, Order No. 54 at 2, 2001 WL 1117935 (U.S.I.T.C., September 19, 2001) (Initial Determination not reviewed by Commission).

The alleged infringer's burden of proof in connection with all three elements of the equitable estoppel defense is a preponderance of the evidence. Aukerman, supra, 960 F.2d at 1046. Moreover, even if all three elements are established, "any other evidence and facts respecting the equities of the parties" must be considered, and the court may exercise discretion in deciding whether to allow the defense of equitable estoppel to bar the suit. Id. at 1043.

## 2. Primary Facts

The primary facts underpinning Vanderlande's equitable estoppel defense are as follows. Rapistan and Vanderlande share a longstanding relationship. [

] See van der Lande Tr. 1603:20-1604:3; CX-217C; **FF 88**  
(First Stipulation No. 93).

[

] CX-217C at 3-4; **FF 364**. During the period of the License Agreement, there was "an enormous amount of cooperation" between Rapistan and Vanderlande, with the parties working together on several projects. Van der Lande Tr. 1605:13-20; **FF 365**. These cooperative efforts included Rapistan's assisting Vanderlande in

securing business from Compaq Computer in Holland in 1992, in which Vanderlande installed Mark 2 Posisorters and other sortation equipment at Compaq's Dutch computer facility. Van der Lande Tr. 1606:1-18 and 21-25; **FF 366**.

On October 31, 1991, Rapistan filed an application for a European patent corresponding to the U.S. '510 patent, which was published on May 6, 1992. RX-126; RX-482C; **FF 367**. The application was granted and issued on March 1, 1995 as the EP '150 patent. RX-130; **FF 368**.

On or around December 2, 1992, personnel from Rapistan's German parent company, Mannesmann Dematic AG, visited the Compaq facility in Holland to investigate and view Vanderlande's installation of the Mark 2 Posisorter. RX-49; RX-613C; **FF 89** (First Stipulation No. 94). While there, the Mannesmann Dematic personnel took photos of the Mark 2 Posisorter. CX-25C; RX-49C; **FF 90** (First Stipulation No. 95). In February 1993, the photos from the Compaq visit were forwarded to Frederick Burkhart, Rapistan's patent lawyer at the law firm of Van Dyke, Gardner, Linn & Burkhart ("the Van Dyke firm"), who prosecuted the PTO application that eventually matured into the '510 patent in the United States. RX-49C; RX-482C; RX-613C; **FF 47 and 91** (First Stipulation Nos. 47 and 96). On May 10, 1993, shortly after the License Agreement had expired, Mr. Burkhart and his firm provided Rapistan with a written opinion concerning Vanderlande's Mark 2 Posisorters at the Compaq installation in Holland. See RX-482C; **FF 92** (First Stipulation No. 97). However, from December 2, 1992 through June 18, 1998,

Rapistan did not inform Vanderlande of any potential patent infringement issue concerning the '510 patent. **FF 93** (First Stipulation No. 98).

[

]Metros Tr. 896:15-

897:7; Bobilin Tr. 1281:20–22; **FF 369**. [

]Metros Tr.

897:6-7; JX-10C (Metros Dep.) at 117:3-6; Bobilin Tr. 1281:23-24; **FF 370**. [

]

Martin Tr. 1899:6-9; **FF 371**. Notwithstanding that directly competitive activity.

Rapistan never sued Vanderlande in Europe on the EP '150 patent. Metros Tr. 897:8-

898:6; 915:11-13; **FF 372**.

[

] Bobilin Tr. 1283:18-21; Brouckman Tr. 252:12-18; van

der Lande Tr. 1617:4-13; **FF 373**. [

]Van der Lande Tr. 1616:19-23; **FF 374**. [

] Martin Tr. 1899:15-21; Edwards Tr. 1438:5-23, 1439:2-4; **FF 375**. Photos of the Posisorters at Fechenheim were shared with counsel for Rapistan between February 27 and March 3, 1998. **FF 95** (First Stipulation No. 100).

The Van Dyke firm's evaluation of the Mark 2 Posisorter shown in the Fechenheim photographs led to an oral opinion being provided to Rapistan's general counsel in June 1998. **FF 96** (First Stipulation No. 104). Subsequently, Rapistan authorized Terry Linn of the Van Dyke firm to send a letter dated June 19, 1998 to Vanderlande stating the following:

Be advised that the system installed by Vanderlande at United Parcel Service in Frankfurt, Germany, would constitute an infringement of at least United States Patent 5,127,510 if made, used, sold, or offered for sale in or imported to the United States of America.

RX-426; **FF 100 and 101** (First Stipulation Nos. 108 and 109). This letter arrived at Vanderlande approximately one month before Vanderlande submitted its bid to UPS. Van der Lande Tr. 1636:14-18; **FF 376**. Vanderlande viewed this letter as a threat to sue it for infringement and a form of intimidation during the bidding phase of the Hub 2000 project. Van der Lande Tr. 1640:6-13; **FF 377**. However, Vanderlande postponed a response to this letter for the duration of the bid process. Van der Lande Tr. 1642:18-1643:3; **FF 378**. [

] JX-10C (Metros Dep.) at 100:14-19; JX-1C (Beasley Dep.) at 82:1-8; JX-3C (Brouckman Dep.) at 59:11-24; Bobilin Tr. 1295:4-8; Martin Tr. 1905:9-15; **FF 379**.

In August 1998, UPS awarded Vanderlande the Hub 2000 contract, which was signed in October 1998. Van der Lande Tr. 1616:9-12; CX-212C-A; **FF 380**.

Rapistan found out that it had lost the bid, and Vanderlande had won the bid, in September 1998. Metros Tr. 901:17-22; **FF 97** (First Stipulation No. 105). [

] **JX-1C** (Beasley Dep.) at 87:8-16, 88:1-4; **RX-99C**; Martin Tr. 1902:2-22; **FF 381**; **FF 98 and 99** (First Stipulation Nos. 106 and 107). At that meeting, UPS told Rapistan's attendees that Vanderlande would use the Mark 2 Posisorter for Hub 2000. **RX-99C**; **JX-1C** (Beasley Dep.) at 88:13-15; **FF 382**. Later in 1998, during discussions among James Brouckman (Rapistan's executive vice-president), John Raab (Rapistan's vice-president of marketing) and Earl Beasley (one of Rapistan's employees on the Hub 2000 bid project), Raab told Brouckman that Vanderlande was "allegedly going to use the Posisorter, which would then infringe upon the patent rights of the RS 200 and that if sales wanted to take any kind of action, this was – this would be an appropriate time to take action." **JX-13** (Raab Dep.) at 68:3-8; 68:10-11; **FF 383**.

On December 8, 1998, Brouckman of Rapistan wrote a letter to Rein van der Lande, then the president of Vanderlande, to propose that Vanderlande buy the RS200 from Rapistan for use at the Hub 2000 facility. **CX-583C**; **FF 384**; **FF 102** (First Stipulation No. 111). The letter was reviewed and commented upon by Rapistan's counsel, Burkhart, before being sent. **JX-26C** (Burkhart Dep.) at 110:6-19; **FF 385**. In his letter, Brouckman characterized his offer to Vanderlande as follows:

This is a win-win situation for everybody. UPS gets proven technology they have already accepted with local US support, you get out from under the potential of a patent infringement on this product, and we get some business.

CX-583C; FF 386. At trial, Rein van der Lande characterized his reaction to this letter at the time as “a threat and also somewhat an opportunistic letter.” Van der Lande Tr. 1619:14-18; FF 387.

On January 29, 1999, Rein van der Lande wrote back to Brouckman rejecting the Rapistan offer. CX-584C; FF 388. In the letter, van der Lande also acknowledged receipt of the earlier letter from Linn of the Van Dyke firm, and further stated as follows:

From the beginning we were of the opinion that we do not infringe the patents referred to in the above-mentioned letter and this opinion has in the meantime been confirmed by US counsel’s opinion.

Taking the above into account we do not see a reason to discuss your offer to conclude a cooperation for the Hub 2000 project of UPS.

CX-584C; FF 389.

Van der Lande testified at trial that after his letter was sent in January 1999, “[w]e didn’t hear back from anyone, and therefore, we believed that Brouckman and his law firm agreed with our position. And as a matter of fact, two months after sending the letter and not having heard anything from Rapistan, or the attorneys, I called our counsel, Freshfields in Amsterdam, and asked them to close our files.” Van der Lande Tr. 1621:23-1622:5; FF 390; FF 103 (First Stipulation No. 112).

Pete Metros, the president and CEO of Rapistan, testified at trial about Rapistan’s actions after the UPS contract for Hub 2000 was awarded to Vanderlande.

According to Metros, when the Brouckman letter was sent in December 1998, he was aware of the possibility that Vanderlande would import Mark 2 Posisorters for the project, but was uncertain as to whether Vanderlande would do so because “they had an option” to use other products. Metros Tr. 902:13-18, 903:11-14; FF 391. Metros testified that he was still uncertain whether Vanderlande would use the Mark 2 Posisorter for the Hub 2000 project even after Rapistan received Vanderlande’s January 1999 rejection of the Linn and Brouckman letters. Metros Tr. 905:22-907:5; FF 392. Metros also testified that Rapistan did not inform UPS of its infringement position on the Mark 2 Posisorter because it would be unethical “to get the customer in the middle of this” and would be “negative selling.” Metros Tr. 909:14-910:3; FF 393. Metros also stated, in answer to a question as to whether he would always authorize a lawsuit for patent infringement if advised by his employees that he could do so, as follows:

Gentlemen, lawsuits cost a lot of money. I think every case has to stand on its own merits relative to pursuing a lawsuit. I would tell you that, as a matter of our philosophy, that we protect our patented products, but I would tell you, in all cases, we would not do that.

Metros Tr. 918:17-25; FF 394.

At approximately the same time as Vanderlande was closing its legal file on the Linn and Brouckman letters, by a contract dated May 3, 1999, Rapistan, under its former name Mannesmann Dematic Rapistan Corp., entered into an agreement with UPS to install a system for the sortation of “irregular-sized” packages at the Hub 2000 facility (the “irregulars system” or “irregulars project”). RX-313C; FF 395. The irregulars system deals with irregular-shaped packages or parcels that cannot be



handled on the normal transport system. Van Helmond Tr. 1317:19-21; **FF 396**. It is more akin to a traditional airport baggage-handling system, and uses such equipment because of the size of the cargo. JX-7C (Langen Dep.) at 22:12-20; **FF 397**. The main system installed by Vanderlande and the irregulars system physically go “one over the other” at Hub 2000. Brouckman Tr. 265:5-7; RPX-17; **FF 398**. [

] Martin Tr. 1904:1-4; RPX-17; **FF 399**. The controls of the main system and the irregulars system share electronic information between them. JX-9C (Litchfield Dep.) at 52:3-53:24; RX-247; **FF 400**.

The bidding and installation of the irregulars system at Hub 2000 was handled by a team from Rapistan’s German affiliate, Mannesmann Dematic of Offenbach, Germany. Rapistan argues that the Grand Rapids-based company known as Rapistan is a different company from the Offenbach-based Mannesmann Dematic company that handled the irregulars project. CIB 160. Karl-Heinz Langen, a member of the board of directors of Mannesmann Dematic, submitted the bid to UPS and handled the layout work. JX-7C (Langen Dep.) at 7:21-23, 13:9-12, 31:1-3, 11-17; RX-313C at R030191; **FF 401**. According to Rapistan, the contract was placed in the name of Rapistan at the time merely as a legal formality because the German affiliate did not operate in the United States. See JX-9C (Litchfield Dep.) at 90:24-92:19; **FF 402**. Langen testified at his deposition that the Offenbach-based German team did not

communicate with Grand Rapids-based Rapistan regarding the project. See JX-7C (Langen Dep.) at 21:22-22:7, 28:18-21, 32:25-33:2, 56:7-57:19; **FF 403**.

[

] Martin Tr. 1909:7-14; **FF 404**. Moreover, Mannesmann Dematic's project manager on the irregulars project, David Litchfield, testified at his deposition that as of 2000, when he was placed on the payroll of Rapistan, he was not uncomfortable with the arrangement because the relationship of Rapistan to Mannesmann Dematic was "close enough" in his view. See JX-9C (Litchfield Dep.) at 100:6-18; **FF 405**. Litchfield also testified that he communicated with a Rapistan employee as his contact with the purchasing department for dealing with his U.S. subcontractors on the project. JX-9C (Litchfield Dep.) at 102:7-19; **FF 406**. Litchfield also termed the relationship between Rapistan and Mannesmann Dematic on the irregulars project as a "subcontract" from Rapistan to Mannesmann Dematic's German affiliate. JX-9C (Litchfield Dep.) at 108:8-109:7; **FF 407**. Thus, although it is evident that Mannesmann Dematic's German personnel were the primary workers on the Hub 2000 irregulars project, Rapistan's U.S. operations were directly involved.<sup>21</sup>

Vanderlande argues that the close proximity of Rapistan's irregulars system to Vanderlande's Mark 2 Posisorter system at the Hub 2000 facility necessitated a

---

<sup>21</sup>Hereafter, for convenience, references to Mannesmann Dematic in connection with the team from Offenbach, Germany that worked on the irregulars system of the Hub 2000 project will instead be to "Rapistan."

“cooperative effort” between Rapistan and Vanderlande personnel so that their systems would be compatible. RIB 139-41. Henk van Helmond, Vanderlande’s contract manager on the project, testified at trial that Vanderlande and Rapistan had to interface with each other as part of their contractual obligations to UPS because of limited space available in the building site. Van Helmond Tr. 1320:17-1321:9; **FF 408**. Van Helmond further testified that he met several times with Litchfield of Rapistan and had meetings with Rapistan personnel both at Vanderlande’s headquarters in Veghel, The Netherlands, during the design phase of the project as well as on-site at Louisville, Kentucky during installation, the latter occurring on a weekly basis. Van Helmond Tr. 1321:10-1322:15; **FF 409**. [

] Martin Tr. 1904:5-1905:8;

**FF 410**.

Litchfield of Rapistan testified at his deposition that he did not meet with any Vanderlande people during his trips to Louisville in 1999, but that he did have one visit to Vanderlande at Veghel in mid-September 1999 together with Achim Planz, an employee of Mannesmann’s airport department in Germany, and Wayne Speir of UPS, for the purpose of finding a path for the irregular system through some

complicated areas where Vanderlande had “an awful lot of equipment” and to “check[ ] layouts and interfaces so that the conveyor systems did not clash with each other.” JX-9C (Litchfield Dep.) at 27:11-22, 28:24-29:5, 30:10-22; **FF 411**. According to Litchfield, UPS chaired the meeting to resolve the problem, “[a]nd the only way was to get our system designer there and the Vanderlande system designer, so they could literally sit next to each other” and move conveyors on a drawing “to make sure they miss”each other. JX-9C (Litchfield Dep.) at 32:2-12; **FF 412**. They worked with a composite layout drawing that showed the conveyor path for each of the two parties but lacked details, and they tried to integrate the two conveyors to make sure that both could be installed. JX-9C (Litchfield Dep.) at 33:20-34:14; **FF 413**.

It is therefore evident that there was a contractual obligation and at least some direct cooperation and meetings between Rapistan and Vanderlande at the behest of UPS during the design and installation of the irregulars system at Hub 2000, but the facts do not suggest that the relationship was particularly warm or “cooperative.” Rather, the facts suggest that both parties did whatever UPS wanted them to do when asked, and no more.

The first Vanderlande Mark 2 Posisorters arrived at the Hub 2000 facility in September or October 1999. Van Helmond Tr. 1342:24-1343:2; **FF 414**. Vanderlande installed the first Mark 2 Posisorter at the Hub 2000 facility commencing in November 1999. Van Helmond Tr. 1314:22-25; **FF 415**. Posisorter parts were kept on the floor of the work area in full view of anyone working on the

project and were never concealed. Van Helmond Tr. 1316:19-1317:7; 1320:7-16; **FF 416**. Langen of Rapistan saw Posisorter parts there when he first visited the site in February 2000, although he was not aware at the time that they were Vanderlande Posisorter parts. JX-7C (Langen Dep.) at 40:24-41:22; **FF 417**; **FF 104** (First Stipulation No. 114).

The performance of the Hub 2000 project was divided into several phases: engineering, procurement, installation, testing, commissioning, and integration. Van Helmond Tr. 1313:10-14; **FF 418**. The engineering phase began in October 1998 when Vanderlande obtained the contract, and ended in 2000. Van Helmond Tr. 1313:15-24; **FF 419**. In October 1999, during the engineering phase, Vanderlande first gained access to the Hub 2000 facility. Van Helmond Tr. 1314:8-11; **FF 420**. In January 2000, the German team from Rapistan arrived at Hub 2000 to commence work on the irregulars system. Van Helmond Tr. 1319:17-19; **FF 421**. The next phase, procurement, lasted until July 2001. Van Helmond Tr. 1313:25-1314:7; **FF 422**. The next phase, installation, was implemented in three overlapping phases: Phase I, started in November 1999 and completed in March 2001, called for 24,000 packages sorted per hour and cost over \$130 million; Phase II, started in March 2000 and completed in August 2001, called for 32,000 packages sorted per hour and cost over \$90 million; and Phase III, started in October 2000 and completed in July 2002, called for 144,000 packages sorted per hour and cost over \$200 million. RIB 148; Van Helmond Tr. 1313:5-9; **FF 423**. Currently, there are 96 Vanderlande Mark 2 Posisorters installed at the Hub 2000 facility. Van Helmond Tr. 1314:12-14; **FF 424**.

On October 3, 2000, Rapistan's lawyers visited the Hub 2000 site to inspect Posisorters, and they provided a written opinion to Rapistan related to their inspection later the same month. JX-26C (Burkhart Dep.) at 98:17-99:5; RX-482C; **FF 425; FF 105** (First Stipulation No. 116). Approximately nine months later, on June 25, 2001, Rapistan filed its Section 337 complaint with the Commission.

[

]

RX-504C; Bobilin Tr. 1298:8-1299:10; **FF 427**.

3. **Did Complainants through misleading words, conduct, and/or silence lead the Respondents to infer that the Complainants did not intend to enforce their patent (*i.e.*, the '510 patent) against the Respondents?**

A patentholder's statements and conduct are examined under the first estoppel element to determine if they "communicate something in a misleading way."

Aukerman, supra, 960 F.2d at 1042. “The ‘something’ . . . is that the accused infringer will not be disturbed by the plaintiff patentee in the activities in which the former is currently engaged.” Id. “In the most common situation, the patentee specifically objects to the activities . . . as infringement . . . and then does not follow up for years.” Id. “However, plaintiff’s inaction must be combined with other facts respecting the relationship or contacts between the parties to give rise to the necessary inference that the claim against the defendant is abandoned.” Id. (citations omitted).

The evidence demonstrates that Rapistan, beginning shortly after the termination of the License Agreement with Vanderlande in 1993 and continuing until 2001, engaged in a consistent course of conduct of not enforcing its patent rights in the ‘510 patent and its European counterpart, the EP ‘150 patent, against Vanderlande’s alleged infringement on the part of its Mark 2 Posisorter system. Rapistan engaged in this course of conduct despite direct competition between Vanderlande and itself for UPS’s business both in Europe and in the United States, and despite Rapistan’s knowledge and the knowledge of its counsel, the Van Dyke firm, of the design of the Mark 2 Posisorter that was learned from two inspections at the Compaq facility in Holland in 1992 and at the UPS facility in Fechenheim, Germany in 1997. Rapistan finally made this knowledge and opinion regarding infringement known to Vanderlande in the June 19, 1998 Linn letter by stating therein that the Mark 2 Posisorter “would constitute an infringement of at least United States Patent 5,127,510 if made, used, sold, or offered for sale in or imported

to the United States of America.” See RX-426. It cannot be doubted, and there is no evidence to the contrary, that the Mark 2 Posisorter must have been viewed by Rapistan as an infringement of the EP ‘150 patent to the same extent as its U.S. counterpart patent, and by not suing Vanderlande for infringement in Europe, Rapistan established a pattern of behavior that continued undisturbed from 1993 until the Linn letter was sent to Vanderlande in June 1998.<sup>22</sup>

The circumstances under which Rapistan engaged in this conduct in Europe were identical to the circumstances that presented themselves to Vanderlande in the United States. In both instances, Rapistan and Vanderlande were direct competitors for UPS’s business; after 1993, they were no longer constrained by the division of markets represented by the License Agreement. The first instance of competition between the two companies that appears in the record occurred, not on Rapistan’s “turf” as matters stood under the expired License Agreement, but on Vanderlande’s – Rapistan sought UPS’s business in Vanderlande’s formerly exclusive European territory by bidding for the Fechenheim project. Despite losing that bid, and despite taking the opportunity to inspect the Mark 2 Posisorter that had been installed in Fechenheim and seeking an infringement opinion from the Van Dyke firm, Rapistan did not assert and has never asserted its rights under the EP ‘150 patent either against

---

<sup>22</sup>There is evidence in the record that Rapistan has been contesting Vanderlande’s European patent claims relating to the Mark 2 Posisorter and the RS200 through interference proceedings for several years. CRB 148 n.58; van den Goor Tr. 1737:10-1739:24; FF 428. However, this proceeding, involving only the future of Vanderlande’s patent rights in Europe, has nothing to do with Rapistan’s failure to enforce its own existing patent rights in Europe against Vanderlande’s alleged infringement of those rights.



Vanderlande for making and selling the Mark 2 Posisorter, or against UPS for using it. [

] See RX-504C; Bobilin Tr. 1298:8-1299:10.

As in Europe, Rapistan and Vanderlande have become direct competitors for UPS's business in the United States as well. Vanderlande has now invaded Rapistan's "turf," the United States, by bidding for and winning the UPS Hub 2000 project. This time, however, Rapistan took a stand against Vanderlande by sending the Linn letter during the bidding phase. Neither party, however, informed UPS at the time. Neither party took any steps during the bidding phase as a consequence of the letter – Rapistan did not sue Vanderlande for infringement despite its right to do so by virtue of Vanderlande's having made an offer for sale to UPS, and Vanderlande did not sue Rapistan for a declaratory judgment of noninfringement despite its right to do so after receiving the Linn letter.<sup>23</sup> Both chose instead to take a "wait and see"

---

<sup>23</sup>As Vanderlande correctly points out (RRB 89 and 96-98), Rapistan could have sued Vanderlande in the U.S. for infringement, or for a declaratory judgment of future infringement, as soon as Rapistan knew that Vanderlande had bid Mark 2 Posisorters for the Hub 2000 project. See 35 U.S.C. § 271(a) ("[W]hoever without authority . . . offers to sell . . . any patented invention, within the United States . . . infringes the patent."); also see Glaxo, Inc. v. Novopharm, Ltd., 110 F.3d 1562, 1570 (Fed.Cir. 1997) ("A patentee may seek a declaration that a person will infringe a patent in the future."); Lang v. Pacific Marine & Supply Co., 895 F.2d 761, 763 (Fed.Cir.1990) (same). Vanderlande's potential for infringement had to have been clear to Rapistan by June 1998, when the Linn letter was sent, or else the warning in that letter would have been unwarranted, as Rapistan readily admits. See CRB 149. By the same token, Vanderlande could have sued Rapistan in the U.S. for a declaratory judgment of non-infringement as soon as it received the Linn letter. See 28 U.S.C. § 2201; also see Amana Refrigeration, Inc. v. Quadlux, Inc., 172 F.3d 852, 855 (Fed.Cir.1999) ("The Federal Circuit applies a two-part test to determine whether

(continued...)

approach until UPS awarded the contract. After the contract went to Vanderlande in August 1998, however, Rapistan still took no action for four more months.

Rapistan's next move came in December 1998, when Brouckman sent his letter to Linn offering to sell the RS200 sortation system to Vanderlande for use at the Hub 2000 facility. See CX-583C. This offer was posited by Rapistan as a "carrot-and-stick" to Vanderlande, or, as Brouckman put it in his letter, "a win-win situation for everybody. UPS gets proven technology they have already accepted with local US support, you get out from under the potential of a patent infringement on this product, and we get some business." Id. Compared to the Linn letter, the Brouckman letter was a much milder overture on Rapistan's part. However, Vanderlande was in no mood to share its "piece of the cake," as Rcin van der Lande termed his company's newfound presence in the United States, and viewed the letter as "opportunistic." See van der Lande Tr. 1610:10-1611:9; 1619:14-18. Contrary to his former reticence during the bidding phase in replying to the more-direct Linn letter, and with the UPS contract now safely awarded to his company, van der Lande replied to Brouckman within two months with a short rejection letter and, hearing nothing further from Rapistan, closed his legal file on the matter within two months after that. See CX-584C; van der Lande Tr. 1621:23-1622:5.

---

<sup>23</sup>(...continued)

a case or controversy exists in a declaratory judgment action seeking a declaration of non-infringement or invalidity of patents. [citation omitted] For an actual controversy to exist, there must be both (1) an explicit threat or other action by the patentee, which creates a reasonable apprehension on the part of the declaratory plaintiff that it will face an infringement suit, and (2) present activity which could constitute infringement or concrete steps taken with the intent to conduct such activity.") (internal quotation marks omitted).

Thereafter, Rapistan relapsed into a two and one-half year silence regarding its rights against Vanderlande under the '510 patent, much as it had done in Europe in connection with the counterpart EP '150 patent for the previous three years. While Rapistan remained quiet, with the full knowledge of its legal counsel, Vanderlande advanced through virtually all phases of the enormous, rapidly-moving, \$430 million Hub 2000 project for UPS, recognized by both parties to be the largest material-handling project either had ever seen up to that time.

Rapistan's slowgoing approach to enforcing its infringement rights in the face of such an enormous undertaking in the industry as the Hub 2000 project must be viewed as indicative of the persistence with which it chose to adhere to its non-litigious course of conduct, and is consistent with the pattern that Rapistan had already established in Europe in connection with the far-smaller UPS project at Fechenheim, Germany. Rapistan's two and one-half year silence in enforcing its patent rights under these circumstances was thus misleading, particularly in view of Vanderlande's clear-cut challenge to Rapistan's infringement position in its January 1999 response to the Brouckman letter, in that these facts "give rise to the necessary inference that the claim against the defendant is abandoned." Aukerman, supra, 960 F.2d at 1042.

The rationales given by Rapistan's president and CEO, Pete Metros, for Rapistan's inaction following UPS's award of the Hub 2000 project to Vanderlande are unavailing when viewed in light of the enormity of the project and the speed with which it proceeded. Metros' contention that he was not certain whether Vanderlande

would use the Mark 2 Posisorter for the Hub 2000 facility (Metros Tr. 902:13-18, 903:11-14, 905:22-907:5) docs not ring true; Rapistan was clearly aware of Vanderlande's intentions even before bids were submitted, as their pre-bid visit to UPS's Fechenheim facility should have made clear. The fact that Vanderlande had "an option" to use other products, as Metros put it (Metros Tr. 902:13-18, 903:11-14) is equally unavailing; rather than promoting inaction, this fact should have prompted Rapistan, if it was serious about its infringement position, to take early steps to prevent an unwarranted expenditure of millions of dollars by UPS and Vanderlande in an infringing product, particularly after Vanderlande had made its noninfringement position clear to Rapistan in January 1999. A patentholder may not "intentionally lie silently in wait watching damages escalate . . . particularly where an infringer, if he had had notice, could have switched to a noninfringing product." Aukerman, supra, 960 F.2d at 1033 (emphasis added). The notion that Rapistan did not tell UPS about its infringement position on the Mark 2 Posisorter for "cthical" reasons (Metros Tr. 909:14-910:3) is particularly puzzling; it would appear that a policy of full disclosure to UPS would have been more "ethical" for both Rapistan and Vanderlande to pursue than the policy of non-disclosure that they both followed. Informing UPS up front would have afforded all three parties an opportunity to resolve the problem at an early stage before substantial resources were committed to the project. The most plausible reason that Metros gave for failing to act sooner was simply that "lawsuits cost a lot of money," (Metros Tr. 918:17-25), but it is evident from Rapistan's

belated filing of the complaint in June 2001 that the amount of lost business at stake ultimately outweighed that concern.

The fact that Rapistan worked side-by-side with Vanderlande in the installation of the irregulars system at the Hub 2000 facility adds an additional dimension to the “necessary inference that the claim against the defendant is abandoned.” Aukerman, supra, 960 F.2d at 1042. Although this evidence of Rapistan’s “cooperation” with Vanderlande does not suggest that “all was forgiven,” it does imply that Rapistan had, and continues to have, an ongoing business relationship with UPS that it does not want to jeopardize. [

] [

] [

] [

] Thus, Rapistan’s ongoing

relationship with UPS, as manifest in its work on the irregulars system for the Hub 2000 project, must have served as a powerful indicator to Vanderlande at the time the project was ongoing that Rapistan would do nothing to jeopardize that relationship by suing Vanderlande for infringement, either in the U.S. or in Europe. See, e.g., ABB, supra, 828 F.Supp. at 1398 (patentee's silence after warning accused infringer implied that patentee had decided to forego suit in order to maintain its business relationship with accused infringer's parent company).

Rapistan contends that the length of its delay in suing Vanderlande was not misleading because it could not have sued before Vanderlande had imported any Mark 2 Posisorters for the Hub 2000 project, an event that did not happen until September or October 1999. CIB 158-59; Van Helmond Tr. 1342:24-1343:2. Even if that were true, it still would not explain Rapistan's additional 20 months of delay in filing its Section 337 complaint with the Commission, as Vanderlande points out. See RRB 94-95. It is not true, however, because under the Commission's precedent, at that time and now, the October 1998 signing of the contract between UPS and Vanderlande for the engineering and installation of the sortation system at the Hub 2000 facility in Louisville, Kentucky constituted a "sale" on which a Section 337 complaint could be brought. See 19 U.S.C. § 1337(a)(1)(B)(i); also see Certain Variable Speed Wind Turbines and Components Thereof, Inv. No. 337-TA-376, U.S.I.T.C. Pub. No. 3003 (November 1996), Initial Determination at 7-19 (June 20, 1996) (adopted by Commission in relevant part) (a "sale" of accused products occurs under Section 337 "if it is determined that Respondents have entered into a contract

for the accused products.”); aff’d sub nom. Enercon GmbH v. U.S. International Trade Comm., 151 F.3d 1376 (Fed.Cir. 1998) (“Wind Turbines”).

UPS told Rapistan shortly after that contract was awarded that Vanderlande would import the Mark 2 Posisorter for installation at the project. See RX-99C; JX-1C (Beasley Dep.) at 88:13-15. Rapistan’s own management knew internally that that moment was “an appropriate time to take action.” See JX-13 (Raab Dep.) at 68:3-8; 68:10-11. Still, Rapistan waited an additional two years and eight months to file suit. Given the impending rapid onset of the engineering and installation of this enormous project after the contract was signed; given the fact that Rapistan had already issued both its warning letter in June 1998 and its “win-win” offer of sale letter in December 1998; and given that Rapistan’s infringement position had been definitively rejected by Vanderlande in January 1999, the “necessary inference” from Rapistan’s silence thereafter is that it was abandoning its infringement claim, as it had already done in Europe. See Aukerman, supra, 960 F.2d at 1042.

Rapistan further argues that it could not have sued Vanderlande earlier than it did because it did not know for a certainty that Mark 2 Posisorters would be used by Vanderlande on the Hub 2000 project until its attorneys from the Van Dyke firm viewed them at the project in October 2000. CRB 149-50; JX-26C (Burkhart Dep.) at 98:17-99:5; RX-482C. According to Rapistan, Vanderlande had other options available to it besides using the Mark 2 Posisorter. CRB 149-50; Brouckman Tr. 214:10-12, 244:19-21; 258:21-259:3. Rapistan also argues in this vein that its counsel would have risked sanctions under Rule 11 of the Federal Rules of Civil

---

Procedure if they had instituted this Section 337 action before engaging in a thorough investigation of the facts of Vanderlande's importation of Mark 2 Posisorters into the United States. See CRB 152-53. Rapistan also contends that in the cases on equitable estoppel that have been cited by the parties, the misleading conduct or inaction giving rise to estoppel involved longer periods of time. See CRB 157-58 and cases cited therein.

As already explained, Rapistan did not have to wait until Vanderlande actually imported Mark 2 Posisorters into the United States in September and October of 1999 in order to have a cause of action under Section 337; it already had that one year earlier, when the contract between Vanderlande and UPS was signed. See Wind Turbines, supra. At that time, Rapistan was well aware of the execution of that contract and of Vanderlande's intention, with UPS's approval, to import Mark 2 Posisorters to fulfill the requirements of the contract. See JX-13 (Raab Dep.) at 68:3-8; 68:10-11. What is more, the Van Dyke firm's June 1998 warning letter to Vanderlande noted the potential for Rapistan to sue not only upon the execution of a contract with UPS, but even beforehand, by stating that Vanderlande would be infringing the '510 patent if the Mark 2 Posisorter was "made, used, sold, or offered for sale in or imported to the United States of America." See RX-426 (emphasis added).

Further, Rapistan and the Van Dyke firm already had all the information that they needed about the Mark 2 Posisorter with which to sue Vanderlande for infringement of the '510 patent on the basis of the offer of that product for sale to



UPS in the United States. Rapistan and the Van Dyke firm had seen the Mark 2 Posisorter as early as 1993, when photos of the product from the Compaq facility in Holland were sent to the law firm, and the Van Dyke firm had already given Rapistan an infringement opinion. See RX-49C; RX482C; RX-613C. [

] See Martin Tr. 1899:15-21; Edwards Tr. 1438:5-23, 1439:2-4. Rapistan's viewing of that installation formed the basis for the Linn letter to Vanderlande the following June. RX-426 ("Be advised that the system installed by Vanderlande at United Parcel Service in Frankfurt, Germany, would constitute an infringement . . . .") (emphasis added).

It strains credulity to accept that Rapistan delayed filing suit against Vanderlande for two and one-half years after the UPS-Vanderlande contract was signed on the ground that Rapistan and the Van Dyke firm felt the need to prepare more thoroughly before commencing litigation. [

]

Every day of delay on a project of such proportion was critical, and it is not enough to argue, as Rapistan has done, that misleading conduct in all of the equitable estoppel cases cited by the parties involved longer periods of time. "Unlike laches,

equitable estoppel does not require the passage of an unreasonable period of time in filing suit.” Aukerman, supra, 960 F.2d at 1042. “[G]iven misleading conduct, there is no reason why equitable estoppel could not arise in three-and-a-half years or even sooner.” Scholle Corp. v. Blackhawk Molding Co., Inc., 133 F.3d 1469, 1473 (Fed.Cir. 1998) (emphasis added).

It makes sense for attorneys to thoroughly investigate the facts and the law before filing lawsuits; indeed, they are obligated to assure that their “allegations and other factual contentions have evidentiary support or, if specifically so identified, are likely to have evidentiary support after a reasonable opportunity for further investigation or discovery” in order to avoid the sanctions of Rule 11 of the Federal Rules of Civil Procedure and its counterpart under the Commission’s Rules of Practice and Procedure, 19 C.F.R. § 210.4, for filing frivolous pleadings. See Fed. R. Civ. P. 11(b)(3) (2002 rev.); 19 C.F.R. § 210.4. In that regard, attorneys in patent cases such as the instant investigation are obligated to make a reasonable pre-filing inquiry that includes construing the claims and comparing the accused device with the construed patent claims in such a manner that “an objectively reasonable attorney would [ ] believe, based on some actual evidence uncovered during the pre-filing investigation, that each claim limitation reads on the accused device either literally or under the doctrine of equivalents.” Antonious v. Spalding & Evenflo Cos., Inc., 275 F.3d 1066, 1074 (Fed.Cir. 2002). It is reasonable to infer from the facts here that the Van Dyke firm had made the necessary inquiry by at least as early as 1993, when it viewed photos of the Mark 2 Posisorter as installed at the Compaq facility in

Holland and gave Rapistan a legal opinion concerning infringement, and at the latest by June 1998, when it sent its letter to Vanderlande warning that Vanderlande's product "would constitute an infringement" of the '510 patent "if made, used, sold, or offered for sale in or imported to the United States of America." See RX-426 (emphasis added).

Under these circumstances, our legal system does not preclude prompt and rapid action when the circumstances require it, even well before the importation of an infringing product into the United States has begun. Here, the enormity of the UPS Hub 2000 project and the disastrous consequences for failure to take effective legal steps at the earliest possible date strongly impel the "necessary inference" that Rapistan, by its two and one-half year silence after the contract was executed, had decided to abandon its infringement claim against Vanderlande, and that conduct in view of Rapistan's subsequent filing of its Section 337 complaint was misleading.

Accordingly, Vanderlande has demonstrated, by a preponderance of the evidence, that the first element of the equitable estoppel defense has been satisfied in that Rapistan's failure to sue, both in Europe and in the United States, constituted misleading conduct.

**4. Did Respondents rely on the misleading conduct?**

"The second element of equitable estoppel that an alleged infringer must show is reliance. In order to prove reliance, the alleged infringer must show that it 'had a relationship or communication with the [patentee] which lull[ed] the infringer into a sense of security' that the infringer's conduct would not invite an infringement

suit. [citations omitted] The fact that an alleged infringer failed to take affirmative actions to protect itself from an infringement lawsuit is evidence of its reliance. [citations omitted]” Forest Laboratories, Inc. v. Abbott Laboratories, 1999 WL 33299123 at \*8 (W.D.N.Y. 1999) (“Forest Laboratories”), citing Aukerman, supra, 960 F.2d at 1043; ABB, supra, 828 F.Supp at 1398-1400. In the present investigation, Vanderlande has demonstrated its reliance on Rapistan’s misleading conduct.

After the License Agreement between Vanderlande and Rapistan ended in 1993, the two companies competed head-to-head for UPS business in Europe. Despite Rapistan’s possession of patent rights under its EP ‘150 patent to positive sortation systems in Europe, and despite Rapistan’s knowledge of the structure of Vanderlande’s Mark 2 Posisorter, Rapistan did not sue Vanderlande for infringement in Europe through 1998, and has not done so ever since. This fact was not lost on Vanderlande’s then-president, Rein van der Lande, when his company prepared to bid on the UPS Hub 2000 project in Louisville, Kentucky:

Q Now, at the time Vanderlande was putting its UPS bid together in 1998, you were – pretty well aware of [the ‘510 patent] at that time, were you not?

A Most likely, but we did not consider that that was an issue also, because we were competing or had been competing with Rapistan on many occasions, many – in several occasions in Europe, including the UPS facility in Frankfurt.

van der Lande Tr. 1635:22-1636:4; **FF 429**. This fact also was not lost on Hermann Miedel, Vanderlande’s former president of its United States operations, who, in response to a question at his deposition of whether there was a “concern on the part

of Vanderlande that a possible infringement action by Rapistan would interfere with the Hub-2K project,” stated that “we installed these sorters in front of Rapistan Dematic in Frankfurt two years ago and they had nothing against it.” See JX-11C (Miedel Dep.) at 114:7-19; FF 430.

When Vanderlande received the Linn warning letter in June 1998 while it was preparing its bid for Hub 2000, van der Lande similarly assessed the reliability of this threat of legal action against his experience with Rapistan in Europe:

Q [reading the Linn letter] . . . “Be advised that the system installed by Vanderlande at United Parcel Service in Frankfurt, Germany would constitute an infringement of at least United States patent 5,127,510 if made, used, sold or offered for sale in or imported to the United States.”

You fully understood what Mr. Linn was telling you there, did you not?

A Yes, I understood. But if I may, Mr. Van Dyke, Mr. Linn wrote this letter, of course upon instigation of Rapistan, in a period in which we, the two companies, were competing for the largest material handling project ever in the world. And I would think that, as part of that bidding process, an intimidating letter would be one of the weapons which Rapistan would use, in the hope that they could scare us off.

Q Could you just read -- I'm sorry.

A And in addition, you can write or Mr. Linn can write that providing something similar to what we provided in Frankfurt would be an infringement of the U.S. patent '510, but then when I read that, I also wonder how come he never wrote me a letter of similar nature after I received a contract for the UPS facility in Europe, because we used the same product and we would be infringing on the same patent for that matter.

van der Lande Tr. 1639:24-1640:22; FF 431. Notwithstanding Rapistan's clear threat of legal action directed toward Vanderlande if the latter submitted a bid for the

Hub 2000 project, Vanderlande relied upon Rapistan's docility in Europe to press forward with the UPS bid. Vanderlande in fact submitted its bid to UPS one month later, without first responding to the Linn letter, without telling UPS of the letter, and without taking any legal action of its own, in the form of a declaratory judgment action of noninfringement or otherwise, to protect itself from Rapistan.

Upon receiving the Brouckman letter from Rapistan in December 1998, which Rein van der Lande viewed as "a threat and also somewhat an opportunistic letter" (van der Lande Tr. 1619:1418), Vanderlande this time responded to Rapistan by obtaining an opinion from its own U.S. counsel that the Mark 2 Posisorter did not infringe the '510 patent, and by informing Rapistan in writing of that opinion. See CX-584C. By this time the UPS contract had been awarded to Vanderlande, and by obtaining its own opinion of counsel that confirmed its position (see van der Lande Tr. 1669:18-24), Vanderlande had more to rely upon than Rapistan's conduct in Europe alone in order to move forward with the contract at that juncture. At that point, Rein van der Lande was confident enough of his position to wait only two months for a response from Rapistan to his letter, and when no response came, he was sufficiently satisfied to authorize his attorneys to close their file on the matter. See van der Lande Tr. 1621:23-1622:5. No protective legal action was undertaken by Vanderlande, and UPS remained uninformed of Rapistan's warnings.

Although obtaining a confirming opinion of counsel understandably encourages an accused infringer to move forward, it does not necessarily shield that person from liability for infringement, even from damages for willful infringement.

See Electro Medical Systems, S.A. v. Cooper Life Sciences, Inc., 34 F.3d 1048, 1056 (Fed.Cir. 1994) (“Possession of a favorable opinion of counsel is not essential to avoid a willfulness determination; it is only one factor to be considered, albeit an important one.”). Given that fact, it is implausible that Vanderlande in general, and a businessman as experienced as Rein van der Lande<sup>24</sup> in particular, would have taken on the enormous responsibility of the fast-moving Hub 2000 project in the face of the threat of a patent infringement suit from Rapistan without more protection than an opinion of counsel,<sup>25</sup> and without informing UPS about the potential danger and any steps being taken to counteract it. It is also unlikely that Rein van der Lande would have lightly dismissed the warning set forth in the Linn letter, even after having received a countering opinion from his own counsel, given his 30-year personal relationship with the Van Dyke firm’s name partners, Daniel Van Dyke and Donald Gardner. See van der Lande Tr. 1630:22-1631:5, 1638:12-22.<sup>26</sup> It is far more

---

<sup>24</sup>At trial, van der Lande testified that he had worked in Vanderlande, which his father had founded, since 1971, had been CEO of the company from January 1981 until April 2002, had a bachelor’s degree in mechanical engineering and a master’s degree in business administration from Northeastern University in Boston, and had received an award from the Queen of The Netherlands for his contributions “to society in general or to industry, export or employment for the region in particular.” Van der Lande Tr. 1595:1-1596:21; FF 432.

<sup>25</sup>Rein van der Lande characterized the opinion of counsel as one that “wasn’t an opinion favorable to us, it was an opinion which confirmed our position, which is quite different.” Van der Lande Tr. 1669:18-24; FF 433. The substance of this opinion of counsel has not been disclosed in this investigation on grounds of privilege, and, as such, has been accorded little substantive weight here. See Order No. 11 (January 4, 2002); van der Lande Tr. 1665:17-1669:9.

<sup>26</sup>Van der Lande testified that he did not know Terence J. Linn, the attorney who authored the June 1998 letter from the Van Dyke firm. See van der Lande Tr.

(continued...)

plausible that Vanderlande relied on Rapistan's actions -- and inactions -- in assessing its business risk.

The additional factor that Vanderlande relied upon was Rapistan's prolonged silence after the January 1999 letter from Rein van der Lande rejecting the Linn and Brouckman letters.<sup>27</sup> This silence was consistent with Rapistan's behavior toward Vanderlande in Europe under identical conditions. As Rein van der Lande testified at trial:

Q In what way does this [January 29, 1999 rejection] letter constitute any reliance by Vanderlande with respect to Rapistan activity?

A At the time of writing the letter, it did not, not on the 29th of January. In the period thereafter, of course it did.

Q So the lack of a reply had a bearing, did impact your behavior; is that correct?

A Yes, because I clearly confirmed to Mr. Brouckman that we would go ahead with importing the product, the alleged product, as referred to in Mr. Linn's letter, and that, in our opinion, there is no infringement whatsoever, even after having received U.S. and Dutch counsel opinion.

---

<sup>26</sup>(...continued)

1637:17-1638:3. He admitted, however, that he knew who the Van Dyke firm was, that he was personally familiar with Daniel Van Dyke, and that Linn's letter had to have been authorized by that firm in order to be sent to Vanderlande. See van der Lande Tr. 1638:4-22; FF 434.

<sup>27</sup>Although Rapistan also had an incentive not to disturb the Hub 2000 project because of its economic stake in the design and installation of the irregulars system, this fact did not play a role in Vanderlande's reliance on Rapistan's behavior. The circumstances of the irregulars project were noted by Vanderlande in this context only in that Rapistan's German team from Offenbach made no mention of patent infringement issues when it came to Vanderlande's headquarters in Veghel, The Netherlands to work jointly with UPS on a problem at the Hub 2000 project. See van der Lande Tr. 1626:5-17; 1681:14-1682:8; FF 435.



van der Lande Tr. 1662:1-12; FF 436. In other words, after both sides had clearly staked out their positions on infringement and notified the other side of those positions, Rapistan's prolonged silence while the massive UPS project progressed rapidly to completion at enormous expense was relied upon by Vanderlande as an acceptance by Rapistan of Vanderlande's position. As Rein van der Lande testified, "the fact that they didn't do anything until – in fact, never ever did anything, meant we went ahead in the execution of the contract." Van der Lande Tr. 1648:18-20; FF 437. In short, every day of Rapistan's silence was, for Vanderlande, an affirmation of the views of Vanderlande's management that Rapistan's warning letters were to be discounted and that Rapistan's European pattern of not enforcing its patent rights against Vanderlande would continue in the United States.<sup>28</sup> See van der Lande Tr. 1635:22-1636:4; JX-11C (Miedel Dep.) at 114:7-19.

Rapistan argues that even if its own conduct was misleading, Vanderlande did not rely on that conduct but rather relied on its own analysis of the situation and the advice of its own U.S. counsel. CIB 164; CRB 145-46. This is of course true, but the evidence is uncontroverted that Vanderlande's "own analysis of the situation" was

---

<sup>28</sup>At trial, Rein van der Lande used a Dutch aphorism, "silence admits," to describe his view of the meaning behind Rapistan's silence. See van der Lande Tr. 1626:18-1627:9. This saying was later used against him in cross-examination, when the suggestion was made that van der Lande's six-month silence after receiving the Linn letter constituted an admission by van der Lande that Rapistan's infringement position in that letter was correct. See van der Lande Tr. 1646:14-1647:20. While this Dutch maxim clearly cuts both ways and has been so used by both Rapistan and Vanderlande, see CIB 163-64; RIB 147-48, it is not the sole basis of this determination of reliance on Vanderlande's part. The basis for this determination is Vanderlande's reliance upon Rapistan's longstanding silence both in Europe and in the United States, despite its patent rights in both places.

that Rapistan would not sue, as in Europe. Rapistan's conduct merely fulfilled Vanderlande's expectations from prior experience.

Rapistan also argues that Vanderlande made its final decision to use the Mark 2 Posisorter for the Hub 2000 project before Rapistan could have filed suit, and therefore that "it is factually, logically and legally impossible for Respondents to prove the second required factor – reliance on any action or inaction of Complainants." CIB 154. As Vanderlande points out in response, however, this contention is incorrect because, as has already been explained above, Rapistan could have sued Vanderlande much sooner than it chose to do. See RRB 103. It is also contrary to the facts of record and Rapistan's own contentions elsewhere because, as Brouckman of Rapistan himself testified several times at trial, Vanderlande had other options available to it on the Hub 2000 project besides using the Mark 2 Posisorter if litigation had ensued. See Brouckman Tr. 214:10-12, 244:19-21; 258:21-259:3; CRB 149-50; RRB 103-04. [

] RX-

449C-A at 18; van der Lande Tr. 1624:11-1626:16; FF 438.

The Staff argues that Vanderlande has failed to prove reliance because it committed to the use of the Mark 2 Posisorter for the Hub 2000 installation in early to mid-1999, "before it had reason to conclude that Rapistan would not sue," and that

the preceding Rapistan letters of June and December 1998 gave Vanderlande “every reason to believe that it would be sued if it imported the Mark 2 Posisorter, and yet it never seriously considered any other option.” SIB 94. This rationale, however, fails to take into account the importance of Vanderlande’s reliance on Rapistan’s earlier longstanding conduct in Europe, in addition to its conduct in the United States, as Vanderlande’s reason to go forward with the Hub 2000 project notwithstanding Rapistan’s warning letters.

Accordingly, Vanderlande has demonstrated, by a preponderance of the evidence, that the reliance element of the equitable estoppel defense has been satisfied in that Rapistan’s longstanding conduct of failure to defend its patent rights in the face of competition from Vanderlande both in Europe and the United States “lulled” Vanderlande into a false “sense of security” that Vanderlande’s conduct “would not invite an infringement suit.” Forest Laboratories, supra.

**5. Would Respondents, due to their reliance, be materially prejudiced if the Complainants are allowed to proceed with their claim under the ‘510 patent?**

The third and final element of the equitable estoppel defense that an accused infringer must show is that it will be materially prejudiced if the patentee is permitted to proceed with an enforcement claim against the alleged infringer. Prejudice may be either economic or evidentiary. Aukerman, supra, 960 F.2d at 1033, 1043. Economic prejudice may be a change of economic position during the period of delay. Id. For example, economic prejudice may arise where the alleged infringer will suffer the loss of monetary investments or incur damages which likely would

have been prevented had the patentee asserted its infringement claim earlier. Id. at 1033. Evidentiary prejudice occurs where an alleged infringer is unable “to present a full and fair defense on the merits, due to the loss of records, the death of a witness, or the unreliability of memories of long past events.” Id.

In the present case, only economic prejudice, not evidentiary prejudice, is alleged by Vanderlande in support of its equitable estoppel defense. See RIB 149-54; RRB 109-10. In particular, Vanderlande alleges prejudice stemming from: (i) its investment in U.S. operations; (ii) its investment in Hub 2000; (iii) its loss of opportunity to consider obviously non-infringing alternatives;(iv) its loss of opportunity to consider exercising the walk-away clause in its contract with UPS for Hub 2000; and (v) the impact on UPS. RIB 150-54; RRB 109.

Of the five allegations of prejudice identified by Vanderlande, the most sizable and tangible by far are its investment in Hub 2000 and the impact of Rapistan’s lawsuit on UPS. Vanderlande alleges that during the three years in which Rapistan knowingly opted not to bring suit, Vanderlande expended over \$300 million towards the fine-tuning, manufacture, importation and installation of Posisorters and related equipment, all to be used by UPS at the Hub 2000 facility. RIB 151-52. An adverse result in this case, according to Vanderlande, would not only seriously undermine its relationship with UPS, its largest customer, but would also have catastrophic effects on UPS. RIB 153. [

]

Martin Tr. 1906:1-5; **FF 439**

[

]

[

][

] See RX-504C. As the only remedy available under Section 337 is prospective and injunctive in nature and damages are not awarded, therefore future shipments of spare parts for the Mark 2 Posisorters at the Hub 2000 facility are to be exempted from any exclusion order or cease-and-desist order that the Commission might issue and any expenditures on the Hub 2000 project made by UPS and Vanderlande cannot be recovered by Rapistan as damages through this investigation. Accordingly, any prejudice to Vanderlande arising out of the Hub 2000 project is moot. By the same token, Vanderlande's allegations of prejudice based on its loss of opportunity to consider non-infringing alternatives during the Hub 2000 project, and its loss of opportunity to consider exercising the walk-away clause of the contract for that project, are equally moot.

In connection with Vanderlande's remaining contention of prejudice stemming from its investment in U.S. operations, Vanderlande argues that in reliance upon Rapistan's misleading conduct, it forged ahead with its plans to penetrate the

U.S. market. RIB 150. [

] Van der Lande Tr.

1627:13-16; FF 443.

The foregoing facts are an insufficient basis on which to base a claim of prejudice stemming from Rapistan's misleading conduct before and during the Hub 2000 project and Vanderlande's reliance on that conduct. These expenditures are not

---

of the type that would likely have been prevented had Rapistan sued Vanderlande earlier. Rather, they are damages that are normally associated with a finding of infringement, particularly when a firm believes from the outset that its product is noninfringing, as Vanderlande did. Vanderlande's economic decisions in this regard "were merely business decisions to capitalize on a market opportunity." Ecolab, supra, 264 F.3d at 1371-72. What is more, to the extent that these expenditures were spawned by the Hub 2000 project and the need to service and maintain that facility after completion of the project, they too are safeguarded by the fact that Vanderlande will be allowed to continue providing spare parts to that project and cannot be assessed damages under Section 337.

Finally, Vanderlande raises "other equitable factors" to consider in the estoppel analysis. RIB 154-55; RRB 110-12. This consideration is required, according to Vanderlande, by the following statement of the Federal Circuit in Aukerman:

Finally, the trial court must, even where the three elements of equitable estoppel are established, take into consideration any other evidence and facts respecting the equities of the parties in exercising its discretion and deciding whether to allow the defense of equitable estoppel to bar the suit.

Aukerman, supra, 960 F.2d at 1043.<sup>29</sup> These "equities," according to Vanderlande, include the fact that Rapistan has "foresworn the very remedy they are ostensibly

---

<sup>29</sup>Although the Staff argues that this passage in Aukerman does not require analysis of other equitable factors absent proof of the required three elements of equitable estoppel, see SRB 30, the factors raised by Vanderlande will be considered nonetheless, in case the findings of this Initial Determination on the 3 elements are reversed on review or appeal.

seeking through this action” by admitting that it does not seek to enforce any Section 337 remedy with respect to UPS. RIB 154; RRB 110. That factor has already been taken into account previously herein, however, and contrary to Vanderlande’s contention, it militates against a finding of prejudice. Vanderlande also protests that Rapistan “systematically sought and gathered confidential information about Vanderlande from former Vanderlande engineers” in their “unlimited desire to ‘learn as much as [they could] about [their] competitor.’” RIB 154-55; RRB 110-11. Such allegations about Rapistan’s competitive methods hardly deserves serious reflection, even in view of Vanderlande’s avowal that, by “sharp contrast,” anyone in the employ of Vanderlande who offers the company a competitor’s confidential information “is asked to leave the business.” RRB 155; Chevalier Tr. 1436:1-13.

Accordingly, Vanderlande has failed to show, by a preponderance of the evidence, that it would be materially prejudiced if Rapistan is allowed to proceed with its claim under the ‘510 patent. Further, having thus demonstrated misleading conduct on the part of Rapistan, reliance on that conduct by Vanderlande, but no prejudice to Vanderlande stemming from those factors, Vanderlande has therefore failed to demonstrate that the defense of equitable estoppel applies in this investigation.



## **FINDINGS OF FACT**

### **Parties' Relevant Stipulations of Fact**

- FF 1.** The Complaint in this Investigation was filed on June 25, 2001.
- FF 2.** Supplements to the Complaint were filed on July 9, 2001, and July 13, 2001.
- FF 3.** The Investigation was instituted by the Commission on July 19, 2001.
- FF 4.** The Notice of Investigation was published in the Federal Register on July 25, 2001, at 66 Fed. Reg. 38741.
- FF 5.** The Response to the Complaint and Notice of Investigation was filed on August 21, 2001.
- FF 6.** Leave to file an Amended Response to the Complaint and Notice of Investigation was filed on October 1, 2001 and was granted October 16, 2001.
- FF 7.** Complainant Rapistan Systems Advertising Corp. is a Delaware corporation with its principal place of business located at 425 Plymouth Avenue N.E., Grand Rapids, Michigan 49505.
- FF 8.** Complainant Siemens Dematic Corp. (Siemens Dematic), formerly known as Mannesmann Dematic Rapistan Corp., is a New York corporation with its principal place of business located at 507 Plymouth Avenue N.E., Grand Rapids, Michigan 49505.
- FF 9.** Rapistan Corp. was a predecessor company to Complainant Siemens Dematic.

- FF 10.** On June 28, 1991, Rapistan Corp. assigned all of its rights, title and interest in the '510 patent to Rapistan Demag Corp.
- FF 11.** On August 1, 1997, Rapistan Demag Corp. changed its name to Mannesmann Dematic Rapistan Corp.
- FF 12.** Mannesmann Dematic Rapistan Corp. was an affiliate of Mannesmann Dematic AG, a worldwide material handling company.
- FF 13.** In November 1998 Rapistan Systems Advertising Corp. was incorporated in Delaware as a wholly-owned subsidiary of Mannesmann Dematic Rapistan Corp.
- FF 14.** On December 1, 1998, Mannesmann Dematic Rapistan Corp. assigned all of its right, title and interest in and to the '510 patent to Rapistan Systems Advertising Corp.
- FF 15.** On December 1, 1998, Rapistan Systems Advertising Corp. granted an exclusive license of whatever rights it had in the '510 patent to Mannesmann Dematic Rapistan Corp., now Siemens Dematic Corp.
- FF 16.** On or about May 7, 2001 Mannesmann Dematic Rapistan Corp. became Siemens Dematic Corp.
- FF 17.** The '510 parent patent application was filed on October 31, 1990.
- FF 18.** The inventors named on the '510 parent patent application assigned their rights to Rapistan Corp. in October 1990.
- FF 19.** Rapistan Demag Corp. previously sued Hytrol Conveyor Company, Inc. for infringing United States Patent No. 5,127,510.

- FF 20.** The patent infringement action with Hytrol Conveyor Company, Inc. was settled.
- FF 21.** Respondent Vanderlande Industries Nederland BV is a Netherlands corporation with its principal place of business located at Vanderlandelaan 2, Veghel 5466 RB, Netherlands.
- FF 22.** Respondent Vanderlande Industries, Inc. is a Delaware corporation with its principal place of business located at 1765 West Oak Parkway, Suite 700, Marietta, Georgia 30062-2260.
- FF 23.** Respondent Vanderlande Industries, Inc. has a branch office located at 8001 Crittenden Drive, Louisville, Kentucky 40209-1716.
- FF 24.** The '510 patent, entitled "Modular Diverter Shoe and Slat Construction," issued on July 7, 1992, based on an application (Application Serial No. 07/758,340) filed on August 28, 1991, that was a continuation of Application Serial No. 07/606,585, filed on October 31, 1990, now abandoned.
- FF 25.** The effective filing date of the '510 patent is October 31, 1990.
- FF 26.** The '510 patent has fifty-one claims.
- FF 27.** The five independent claims of the '510 patent are claims 1, 13, 23, 30 and 42.
- FF 28.** Complainants are asserting independent claims 1, 13, 23, 30, and 42, and dependent claims 4, 17, 20, 22, 27, 29, 33, 35, 43, and 45 of the '510 patent.

- FF 29.** Claim 1 of the '510 patent is an independent claim.
- FF 30.** Claim 4 of the '510 patent depends from claim 1.
- FF 31.** Claim 13 of the '510 patent is an independent claim.
- FF 32.** Claim 17 of the '510 patent depends from claim 13.
- FF 33.** Claim 20 of the '510 patent depends from claim 13.
- FF 34.** Claim 22 of the '510 patent depends from claim 13.
- FF 35.** Claim 22 of the '510 patent depends from claim 20.
- FF 36.** Claim 23 of the '510 patent is an independent claim.
- FF 37.** Claim 27 of the '510 patent depends from claim 23.
- FF 38.** Claim 29 of the '510 patent depend from claim 23.
- FF 39.** Claim 29 of the '510 patent depends from claim 27.
- FF 40.** Claim 30 of the '510 patent is an independent claim.
- FF 41.** Claim 33 of the '510 patent depends from claim 30.
- FF 42.** Claim 35 of the '510 patent depends from claim 30.
- FF 43.** Claim 35 of the '510 patent depends from claim 33.
- FF 44.** Claim 42 of the '510 patent is an independent claim.
- FF 45.** Claim 43 of the '510 patent depends from claim 42.
- FF 46.** Claim 45 of the '510 patent depends from claim 42.
- FF 47.** Frederick Burkhart was the attorney responsible for prosecuting the '510 patent application before the United States Patent & Trademark Office ("PTO" or "Patent Office").

- FF 48.** One of ordinary skill in the art with respect to the '510 patent is a person having at least an associate's degree in science and engineering, and from three-to-five years experience in the field of equipment design, including experience in the design and operation of material handling equipment or conveyer sortation equipment, or a corresponding amount of practical experience.
- FF 49.** CPX-8 and RPX-13 are physical exemplars of a reduced length section of a Mark 2 carrier that is representative of the carriers imported and installed at the United Parcel Service Hub 2000 project, in Louisville, Kentucky.
- FF 50.** CPX-9 and RPX-12 are physical exemplars of a Mark 2 diverter shoe that is representative of the diverter shoes imported and installed at the United Parcel Service Hub 2000 project, in Louisville, Kentucky.
- FF 51.** CPX-10 and RPX-14 are physical exemplars of a Mark 2 diverter shoe and reduced length section of carrier that are representative of the diverter shoes and carriers imported and installed at the United Parcel Service Hub 2000 project, in Louisville, Kentucky.
- FF 52.** CPX-12 is a physical exemplar of a diverter rail section that is representative of the diverter rails imported and installed at the United Parcel Service Hub 2000 project, in Louisville, Kentucky.
- FF 53.** CPX-27 and RPX-1A are physical exemplars of a Mark 2 carrier that is representative of the carriers imported and installed at the United Parcel Service Hub 2000 project, in Louisville, Kentucky.

- FF 54.** CPX-28 and RPX-1B are physical exemplars of a Mark 2 diverter shoe that is representative of the diverter shoes imported and installed at the United States Parcel Service Hub 2000 project, in Louisville, Kentucky.
- FF 55.** CX-34(a)C is a true copy of a manufacturing drawing of a Mark 2 carrier that was used in the manufacture of the carriers imported and installed at the United Parcel Service Hub 2000 project, in Louisville, Kentucky.
- FF 56.** CX-176C and RX-443C are copies of a drawing of a Mark 2 carrier that is representative of the carriers imported and installed at the United Parcel Service Hub 2000 project, in Louisville, Kentucky.
- FF 57.** CX-28C is a true copy of a drawing of a part of a Mark 2 diverter shoe that is representative of the diverter shoes imported and installed at the United Parcel Service Hub 2000 project, in Louisville, Kentucky.
- FF 58.** CX-179C and RX-446C are true copies of a drawing of a Mark 2 diverter shoe that is representative of the diverter shoes imported and installed at the United Parcel Service Hub 2000 project, in Louisville, Kentucky.
- FF 59.** CX-31C and RX-362C are true copies of a drawing of a Mark 2 carrier that is representative of a carrier used by Respondents for current Mark 2 Posisorter installations other than for United Parcel Service.
- FF 60.** CX-175C and RX-442 are true copies of a drawing of a Mark 2 carrier that is representative of a carrier used by Respondents for current Mark 2 Posisorter installations other than for United Parcel Service.

- FF 61.** CX-31C and CX-175C depict the shoe and carrier configuration sold by Respondents to Genesco to be installed in the United States.
- FF 62.** CX-225C, RX-343C, and RX-455C are true copies of a drawing of a divert unit assembly representative of assemblies imported and installed at the United Parcel Service Hub 2000 project, in Louisville, Kentucky.
- FF 63.** CX-226C and RX-456C are true copies of a drawing of a divert unit assembly representative of assemblies imported and installed at the United Parcel Service Hub 2000 project, in Louisville, Kentucky.
- FF 64.** CX-227C and RX-457C are true copies of a drawing of a divert unit assembly representative of assemblies imported and installed at the United Parcel Service Hub 2000 project, in Louisville, Kentucky.
- FF 65.** CX-214 is a true copy of materials distributed by Respondents in the United States.
- FF 66.** The accused product is known as the Mark 2 Posisorter (also known as the Mark II Posisorter). The sole difference between the Mark 2 and the Mark II is one of nomenclature.
- FF 67.** The accused product is made by or on behalf of Respondents.
- FF 68.** The accused Mark II Posisorter has no contact between its diverter shoe and its upper conveying surface of the slat during normal usage.
- FF 69.** The accused Mark II Posisorter diverter switch is pneumatically actuated.

- FF 70.** The accused Mark II Posisorter divert switch has a curved portion as shown in CX-225C, CX-226C, CX-227C, RX-343C, RX-455C, RX-456C, RX-457C, RPX-2A, and RPX-2B.
- FF 71.** The accused Mark II Posisorter divert switch rotates horizontally.
- FF 72.** United States Patent No. 3,361,247 (“the ‘247 patent”), entitled “Article Sorting System and Method,” issued on January 2, 1968, based on an application filed on March 28, 1966.
- FF 73.** A true and correct copy of the ‘247 patent was submitted to the Administrative Law Judge as Hearing Exhibit RX-577.
- FF 74.** The ‘247 patent was before the patent examiner during the prosecution of the application that led to the issuance of the ‘510 patent.
- FF 75.** United States Patent No. 3,361,247 is in the same field as the ‘510 patent.
- FF 76.** United States Patent No. 4,884,677 (“the ‘677 patent”), entitled “Package Sortation Conveyor” issued on December 5, 1989, based on an application filed on February 16, 1988.
- FF 77.** A true and correct copy of the ‘677 patent was submitted to the Administrative Law Judge as Hearing Exhibit RX-602.
- FF 78.** The ‘677 patent was before the patent examiner during the prosecution of the application that led to the issuance of the ‘510 patent.
- FF 79.** United States Patent No. 4,884,677 is in the same field as the ‘510 patent.



- FF 80.** United States Patent No. 4,738,347 (“the ‘347 patent”), entitled “Diverter Shoe and Diverting Rail” issued on April 19, 1988, based on an application filed on August 15, 1986.
- FF 81.** A true and correct copy of the ‘347 patent was submitted to the Administrative Law Judge as Hearing Exhibit RX-333.
- FF 82.** The ‘347 patent was before the patent examiner during the prosecution of the application that led to the issuance of the ‘510 patent.
- FF 83.** United States Patent No. 4,738,347 is in the same field as the ‘510 patent.
- FF 84.** During the prosecution of the ‘510 patent, the existence of the CML sorter parts identified as RPX-9, CPX-30 was never disclosed by or on behalf of Complainants to the U.S. Patent Office.
- FF 85.** French published patent application 2,388,737 (RX-220) is prior art to the ‘510 patent.
- FF 86.** French published patent application 2,388,737 (RX-220) is in the same field as the ‘510 patent.
- FF 87.** On March 7, 1990, Hans Bodewes provided the drawings that make up CX-415, and CX-416C and RX-477 (except for the memorandum written by David Cotter) to Rapistan Corp.
- FF 88.** [
- ]
- A true and complete copy of the Licensing Agreement is at CX-217C and RX-452C.

- FF 89.** On or around December 2, 1992, personnel from Mannesmann Dematic AG visited a Compaq facility to investigate and viewed a Vanderlande installation of a Mark 2 Posisorter.
- FF 90.** While at Compaq in 1992, the Mannesmann Dematic AG personnel took photos of a Mark 2 Posisorter. Copies of these photos are at CX-25C and RX-49C.
- FF 91.** In February 1993, photos of the Compaq visit were forwarded to Frederick Burkhart, a patent lawyer for Rapistan Demag Corp.
- FF 92.** Mr. Burkhart and his firm provided Rapistan Demag Corp. with an opinion concerning the Compaq installation on May 10, 1993.
- FF 93.** From December 2, 1992 through June 18, 1998, Rapistan Demag Corp. and Mannesmann Dematic Rapistan Corp. did not inform Vanderlande of any potential patent infringement issue concerning the '510 patent.
- FF 94.** [
- ]
- FF 95.** Photos of the Posisorters photographed at the UPS's Frankfurt Germany facility shown in CX-32C and RX-139C were shared with counsel for Mannesmann Dematic Rapistan Corp. between February 27 and March 3, 1998.
- FF 96.** The Van Dyke firm's evaluation of the Mark 2 Posisorter shown in the photographs of CX-32C and RX-139C led to an oral opinion being

provided to Mannesmann Dematic Rapistan Corp.'s general counsel in June 1998.

- FF 97.** By September 22, 1998, Mannesmann Dematic Rapistan Corp. had learned that UPS accepted Vanderlande's bid over its bid.
- FF 98.** On October 15, 1998, several employees of Mannesmann Dematic Rapistan Corp. visited UPS headquarters in Atlanta, Georgia in order to meet with Mike Martin.
- FF 99.** The employees who made the October 15, 1998, trip to UPS headquarters were Earl Beasley, Roy Freas, Al Cianfarani and Mark Mills.
- FF 100.** A true and correct copy of Terence Linn's letter to Rein van der Lande dated June 19, 1998, is at CX-144, CX-582 and RX-132C.
- FF 101.** Mr. Linn was authorized by Mannesmann Dematic Rapistan Corp. to send his letter of June 19, 1998, which is at CX-144, CX-582 and RX-132C, to Rein van der Lande.
- FF 102.** CX-148, CX-583 and RX-612C is a true and accurate copy of a letter sent by James C. Brouckman to Rein Van Der Lande on December 8, 1998.
- FF 103.** Rein Van Der Lande's January 29, 1999, letter to Jim Brouckman, a true and correct copy of which is CX-149, CX-584 and RX-134C, was the last communication between the parties concerning possible patent infringement or the patent-in-suit until Complainants commenced this investigation in late June of 2001.

**FF 104.** In February 2000, Karl Langen, a senior project engineer for Mannesmann Dematic A.G. visited the Hub 2000 facility.

**FF 105.** On October 3, 2000, Mr. Burkhart (a lawyer from the Van Dyke firm), Jeff Heinze, and Earl Beasley visited the Hub 2000 facility and had access to visually inspect the Posisorters installed by Vanderlande.

**FF 106.** If the Administrative Law Judge finds that Complainants have satisfied the technical prong of the domestic industry analysis, they have satisfied the economic prong of the domestic industry requirement.

**FF 107.** Respondents have imported into the United States 90,000 shoes and slats for use in a Mark 2 Posisorter in the United States.

#### **Administrative Law Judge's Findings of Fact**

**FF 108.** In the "Background of the Invention" section of the specification of the '510 patent, the following language is found:

Movement of the shoes is effected by a guide pin and coaxial bearing, depending from the shoe, which engage a network of guide tracks beneath the conveying surface. . . . When a package is to be diverted to a spur, a diverter switch is actuated to switch the guide pins for the shoes adjacent the package onto a diagonal track which causes the affected shoes to glide across the slats to divert the package.

CX-1 ('510 patent, col. 1:23-33).

**FF 109.** In the "Description of the Preferred Embodiment" section of the specification of the '510 patent, the following language references Figure 2 of the '510 patent:

Movement of the shoe is guided by a network of guide tracks 39 engaging a bearing 56 and changes in direction of movement are

initiated by a diverter switch (not shown) engaging a diverter pin 54.

CX-1 ('510 patent, col. 3:11-14).

**FF 110.** In connection with the diagonal track, the specification of the '510 patent states as follows: "When a package is to be diverted to a spur, a diverter switch is actuated to switch the guide pins for the shoes adjacent the package onto a diagonal track which causes the affected shoes to glide across the slats to divert the package." CX-1 ('510 patent, col. 1:28-33).

**FF 111.** Bernard Woltjer, one of the named inventors of the '510 patent, testified at trial: "Well, the track means is what I refer to as the angular divert means when I was doing this demonstration. The track means is, in this model, the orange bar that goes across, and it's the member that forces the shoes to travel across the slats . . ."). Woltjer Tr. 328:7-15, 486:19-487:1.

**FF 112.** The only structure shown in the body of the '510 patent that has anything to do with a track is a small portion of the "network of guide tracks 39" that is depicted in Figure 2. See CX-1 ('510 patent, Fig. 2 (part)).

**FF 113.** This small portion of the "network of guide tracks 39" is only of a part of the track that parallels the direction of flow. It does not depict the diagonal part of the track system that performs the claimed function of imparting lateral movement to the shoe. See Hoct Tr. 1962:5-22; Cotter Tr. 627:15-630:10.

**FF 114.** The written description of the '510 patent goes on to state that "[p]ositive displacement sortation systems, such as the type disclosed in U.S. Pat. No.

4,738,347 for DIVERTER SHOE AND DIVERTING RAIL, issued to Gerald A. Brouwer and assigned to the present assignee, have long been known." See CX-1 ('510 patent, col. 1:14-18).

**FF 115.** The written description of the '510 patent describes this system as having "a network of guide tracks beneath the conveying surface." See CX-1 ('510 patent, col. 1:25-26).

**FF 116.** This network of diagonal rails is shown in Figure 2 of the '347 Brouwer patent. See RX-333 ('347 Brouwer patent, Fig. 2).

**FF 117.** The written description of the '510 patent states that "[t]he modular slats and diverter shoes provided by the present invention are intended to be used in combination with a vertically-actuated diverter switch, as disclosed in commonly-owned U.S. Pat. No. 5,038,912 for a VERTICALLY ACTUATED TRANSFER SYSTEM filed concurrently herewith, David H. Cotter inventor, the disclosure of which is hereby incorporated herein by reference." See CX-1 ('510 patent, col. 5:50-57).

**FF 118.** Figure 1 of the '912 Cotter patent similarly depicts a track network that includes diagonal rails. CX-2 ('912 Cotter patent, Fig. 1).

**FF 119.** The written description of the '510 patent also states that "[b]i-directional diverter shoes are intended to be used in a bi-directional diverting sortation system utilizing a cross-over switch of the type disclosed in commonly-owned co-pending application Ser. No. 606,504 for a TRACK INTERSECTION PIN GUIDE filed concurrently herewith, David H.

Cotter, inventor, the disclosure of which is hereby incorporated herein by reference.” See CX-1 (‘510 patent, col. 5:57-64). That application eventually issued as U.S. Letters Patent No. 5,235,100 to Cotter, et al. CX-3.

**FF 120.** The ‘100 Cotter patent similarly depicts in Figure 1 a track network including a “diagonal track 19.” CX-3 (‘100 Cotter patent, Fig. 1).

**FF 121.** The shape of the cross-section of the slat of the preferred embodiment is portrayed in Figure 3 of the ‘510 patent. See CX-1 (‘510 patent, Fig. 3).

**FF 122.** Rapistan’s expert, Radcliffe, testified that with a right circular cylinder, in which the cross-sectional curve is a circle, even if the circle were distorted, pushed, or if a kink were put in it such that it is no longer a right circular cylinder, it remains a right cylinder. See Radcliffe Tr. 800:23-801:5.

**FF 123.** Vanderlande’s expert, Hoet, testified that there can be square cylinders. See Hoet Tr. 2026:6-9.

**FF 124.** In the specification of the ‘510 patent, the section on the “Summary of the Invention” states that “[t]he invention is embodied in a sortation system in which each of the slats is defined by a wall having a planar upper portion that defines the conveyor surface . . . .” CX-1 (‘510 patent, col. 1:56-58).

**FF 125.** Figure 3 of the ‘510 patent depicts a cross-section of the slat of the preferred embodiment. See CX-1 (‘510 patent, Fig. 3).

**FF 126.** Upper wall 30 is described in the ‘510 patent as joining forward wall 34 “at an enlarged radius corner 38.” See CX-1 (‘510 patent, col. 3:22-23).

- FF 127.** Vanderlande's expert, Hoet, testified that the term "planar" is equated in engineering terms, "by and large," with the term "flat," and that a slight unevenness or slight variation would not affect the term "planar" in a surface. See Hoet Tr. 2006:4-9. Hoet further testified that upper surface 30 of the slat of the '510 patent as shown in cross-section in Figure 3 deviates from "planar" because of the rounded corners at both ends of the upper surface. See Hoet Tr. 2006:10-19.
- FF 128.** Vanderlande's Manager of Mechanical Development, van den Goor, characterized both the prior art CML sorter as "flat" and the upper conveying surface 86 of his own slat design shown in Figure 14 of Vanderlande's European patent application 0444734 as being "flat, plate-shaped," even though both surfaces have substantial ridges on them. See van den Goor Tr. 1546:10-13; RPX-9; RX-125 (EP '734 application, col. 11:28-29).
- FF 129.** The "flat" CML conveying surface is depicted in Figure 9 of French published patent application 2,388,737 as item 30. See Hoet Tr. 2109:14-16; RX-220 at R527.
- FF 130.** The "flat, plate-shaped" conveying surface of Vanderlande's slat and shoe design in its European patent application 0444734 is shown in Figure 14 as item 86. See RX-125.
- FF 131.** As shown above in Figure 3 of the '510 patent, the lower wall portion of the slat deviates substantially from planar by virtue of its "T-shaped



---

projection 42” that acts as the lateral stabilizing means of the shoe-and-slat combination. See CX-1 (‘510 patent, col. 4:53-61).

**FF 132.** The experts of both Rapistan and Vanderlande agree that the term “glide surface” in the ‘510 patent is distinguishable from a device that rolls or makes rolling contact with another object such as the slat. Hoet, Tr. 1972:7-9, 15-17, 1973:20-1974:13; Cotter Tr. 659:1-3, 676:22-25; van den Goor Tr. 1714:3-7; Radcliffe, Tr. 1355:9-12, 2207-17-2208-22, 2211:4-2212:17, 2221:1-2222:16.

**FF 133.** A dictionary definition of the noun form of “glide” is “a device for facilitating movement of something,” such as a furniture glide. See RX-641; also see RPX-40; Tr. 1771.

**FF 134.** A dictionary definition of the verb form of “glide” is moving “in a smooth, effortless manner” (CX-660) and “moving smoothly, continuously, and effortlessly” (CX-661).

**FF 135.** Claim 1 of the EP ‘150 application states as follows:

[E]ach of the slats (22) is defined by a wall formed as a cylinder including an outer surface having a planar upper portion (3) defining the conveying surface, and each of the diverter shoes (28) has a support portion (44), including a substantially continuous glide surface (50) surrounding the said wall, the glide surface having substantially the same configuration as the outer surface of the slat.

See RX-126 (EP ‘150 application, col. 7:10-18).

**FF 136.** The EPO rejected claim 1 of the EP ‘150 application in view of the published Vanderlande EPO ‘734 patent application showing a design that,

under the laws of the EPO, was “prior art” to Rapistan’s EPO application. The Vanderlande shoe-and-slat design in question was depicted in Figure 14 of the EPO ‘734 application. See RX-125.

**FF 137.** In its rejection of the EP ‘150 application, the EPO likened the “wall formed as a cylinder including an outer surface having a planar upper portion (3)” of Rapistan’s claim 1 to item 86 of Figure 14 of the EPO ‘734 application, and the “substantially continuous glide surface (50) surrounding the said wall, the glide surface having substantially the same configuration as the outer surface of the slat” of Rapistan’s EP ‘150 claim 1 to skids identified as item 89 in EPO ‘734 application Figure 14. See RX-127 at R11634.

**FF 138.** In response to the EPO rejection of the EP ‘150 application, Rapistan argued as follows:

In Claim 1 of the present application, the slat is defined by a wall which has an upper portion defining the conveying surface, and the wall is surrounded by a glide surface of the diverter shoe. This does not appear to be the case in EP 0444734. In annex 1 of the official communication, the Examiner indicated that the planar upper portion (86) of Figure 14 of EP 0444734, as part of the wall, is surrounded by the skids (89), but this does not appear to be the case, because the planar upper portion (86) is above the skids.

See RX-128 at R11625.

**FF 139.** The structure of the Vanderlande design of Figure 14 of the EPO ‘734 application is set forth in the written description that appears in the text of the application as follows:

Figure 14 shows an embodiment of a carrier comprising a flat, plate-shaped upper side 86, which is coupled, by means of two legs 87 extending downwards from said upper side, to a double-walled section part 88 having rounded corners, which extends parallel to the plate-shaped upper side. Complementarily shaped skids 89 of plastic material or the like are provided around the ends of the section part 88, said skids functioning to support a pusher shoe 90 which is movable in the longitudinal direction of the carrier illustrated in sectional view in Figure 14. Said pusher shoe is provided with a pusher part 91 extending above the plate-shaped upper side 86 of the carrier, the ends of said arms, which slope downwards in a direction towards each other, being interconnected by means of a connecting plate 93. The skids 89 are thereby confined, in the manner illustrated in Figure 14, between said connecting plate 93 and supporting arms 95 located between the pusher plate 91 and the connecting plate 93. In the connecting plate there is furthermore provided a hole 96 for a guide means to be mounted therein.

RX-125 (EPO '734 application, at col. 11:28-53).

FF 140. [

] Radcliffe Tr. 1125:7-9; RX-131C at R23165 and R23166.

FF 141. [

]

See RX-131C at R23100-01.

- FF 142.** The experts for both Rapistan and Vanderlande agree that there is a wide variety of different kinds of bearings that are known in the art. See Radcliffe Tr. 874:23-875:20; Hoet Tr. 2031:24-2033:2.
- FF 143.** The bearings used in the '510 patent, according to Rapistan's expert, Radcliffe, are "surface-contact bearings." Radcliffe Tr. 875:2-4.
- FF 144.** According to Vanderlande's expert, Hoet, the bearings used in the '510 patent are "sliding surface bearings." Hoet Tr. 2032:8-11, 15-25.
- FF 145.** Both Radcliffe and Hoet describe the function of the bearings used in the '510 patent in similar terms: Radcliffe, as "hav[ing] contacts between surfaces or portions of surfaces, and one surface presses against the other to provide a force to engage across the bearing;" and Hoet, as "two surfaces that slide past each other." Radcliffe Tr. 875 4-6; Hoet Tr. 2032:19-21.
- FF 146.** The experts for both Rapistan and Vanderlande agree that the vertical walls of T-shaped projection 42 of the preferred embodiment of the '510 patent contact the vertical walls of channel 58 along the lateral axis of the shoe for a sufficient length of the shoe in relation to its width (preferably a ratio of at least 5:1) to perform the claimed functional purpose of "resisting

vertical-axis reaction-force-couples” around axis B (as shown in Figure 8 of the ‘510 patent). See Radcliffe Tr. 935:8-936:14; Hoet Tr. 2038:17-2039:3.

**FF 147.** The written description of the ‘510 patent describes the lateral stabilizer structure as having “[a] definite clearance . . . between the bottom of projection and the bottom of channel 58 for debris tolerance.” CX-1 (‘510 patent, col. 4:61-63. “Debris tolerance” prevents debris from collecting between the lateral stabilizer projection of the slat and the channel of the shoe so that the shoe does not jam. See Cotter Tr. 625:14-626:19.

**FF 148.** The “T”-shape of the disclosed structure of the lateral stabilizer of the preferred embodiment of the ‘510 patent does not affect its claimed function of “resisting vertical-axis reaction-force-couples,” since it is only the correspondence of the vertical walls of the “T” shape with the vertical walls of the channel, and the lateral length of the shoe channel in relation to the shoe’s width, that affect the claimed function. Radcliffe Tr. 1247:24-1248:19.

**FF 149.** The specification of the ‘510 patent describes three embodiments of diverting member -- a “bi-directional” member that can push packages laterally to both sides of the conveyor, and a “right-handed member” and “left-handed member,” each of which can push packages to only one side or the other, respectively. See CX-1 (‘510 patent, cols. 3:66-67 and 4:27-44).

**FF 150.** The specification describes the bi-directional diverting member (item 46a)

as follows:

A diverting member 46a is provided that is designed for use [on] a bi-lateral diverting sortation system. Diverting member 46a includes a right vertical diverting surface 78b. Diverting surfaces 78a and 78b are covered with a high friction polymeric band 80a, 80b. A series of contiguous deflecting surfaces 82a, 82b, 82c, 82d, 82e, 82f, 82g, 82h, 82i, 82j and 82k slope downwardly from diverting surfaces 78a, 78b toward the central axis A of diverting member 46a and forwardly and rearwardly with respect to the movement of the diverting member, which is in the direction of axis A. Therefore, a package striking any of the surfaces 82a-82k will be deflective progressively upwardly to a point where the upper extent of the vertical diverting surfaces 78a, 78b may pass beneath the package.

CX-1 ('510 patent, cols. 3:66-4:13).

**FF 151.** The bi-directional, right-hand and left-hand diverting members of the invention of the '510 patent are depicted in Figures 4, 5 and 6 of the patent.

See CX-1 ('510 patent, Figs. 4-6).

**FF 152.** The right-hand diverting member of Figure 5 and the left-hand diverting member of Figure 6 do not depict similar axis lines, but the written description of the '510 patent makes clear that "axis A" of the bi-directional diverting member corresponds to the "laterally opposite side 92" of the right-hand member and to the "opposite lateral side 94" of left-hand member. See CX-1 ('510 patent, col. 4:27-43).

**FF 153.** The Mark 2 Posisorter system is, as required by claim 1, "a conveying system having a longitudinally moving conveying surface defined by the

uppermost ones of a plurality of slats connected at opposite ends in spaced relation with each other to a pair of endless chains.”

**FF 154.** The Mark 2 Posisorter system has “a plurality of diverter shoes each moveably mounted on one of said slats for lateral movement with respect to said conveying surface.”

**FF 155.** The Mark 2 Posisorter system utilizes a diagonally oriented rail or track that is engaged by a coaxial bearing on the underside of the diverter shoe. Radcliffe Tr. 793:5-795:5, 1243:21-1245:14; Hoet Tr. 1954:10-1956:1; CX-221C; CPX-12; CPX-28.

**FF 156.** The track of the Mark 2 Posisorter system imparts a lateral force to move the diverter shoes laterally in a manner that displaces product positioned on the conveying surface. Hoet Tr. 1954:10-1956:1.

**FF 157.** Consistent with the diverter switch disclosed by the prior-art Brouwer ‘347 patent that is referenced by the specification of the ‘510 patent, the Mark 2 Posisorter system utilizes diverter switches that are moved by pneumatic controls and are pivoted horizontally. Hoet Tr. 1956:2-9; RX-333 (Brouwer ‘347 patent, cols. 3:41-58, 6:21-43).

**FF 158.** A cross-section of the slat of the Mark 2 Posisorter is depicted in CDX-14. CDX-14.

**FF 159.** The slat of the Mark 2 Posisorter system is defined by an outer wall, and that wall forms a “right cylinder” in that it forms a geometrically closed curve. See Radcliffe Tr. 811:13-14.

- FF 160.** The internal connecting wall of the slat of the Mark 2 Posisorter system on the right side of the profile of the slat provides inner support but does not contribute to the outer shape of the slat. Radcliffe Tr. 1190:19-22.
- FF 161.** The two “drip edges” protruding from each end of the upper surface of the slat of the Mark 2 Posisorter system function to provide a sharp break so that liquids will not roll down the sides of the slats and damage the side channels. Van den Goor Tr. 1479:3-22; Radcliffe Tr. 1191:3-14; Hoet Tr. 2012:21-2014:13.
- FF 162.** The ridges on the top conveying surface of the Mark 2 Posisorter slat make a channel for liquids so that spilled liquids stay on the sorter until they are spilled off when the slat reaches the end of the sorter, and also so as to direct liquids to the lateral ends of the slats, away from the guide channels. Van den Goor Tr. 1480:3-1481:8; Hoet Tr. 2012:21-2014:13.
- FF 163.** The ridges on the top conveying surface of the Mark 2 Posisorter slat provide increased friction to reduce or prevent packages from rotating when the sorter is sorting packages with soft bottoms, and also increase the stiffness of the slat. Van den Goor Tr. 1480:3-1481:8.
- FF 164.** The two circular bolt-mounting holes are used to attach the diverter shoe of the Mark 2 Posisorter system to the conveyor chain that is used to move the slat and add stiffness to the slat. Van den Goor Tr. 1481:19-1482:6, 1482:11-12.



- FF 165.** The short side channel flange on the trailing side of the Mark 2 Posisorter slat resists reaction forces and stabilizes the diverter shoe. Radcliffe Tr. 814:18-25; van den Goor Tr. 1482:22-1483:4.
- FF 166.** The Mark 2 Posisorter slat has “a planar upper portion” defining the conveying surface. Radcliffe Tr. 810:15-811:10; CDX-9; CDX-23.
- FF 167.** The ridges on the top conveying surface of the Mark 2 Posisorter slat help prevent jams and allow for the sortation of thin packages, such as letters. Van den Goor Tr. 1483:13-22.
- FF 168.** If a container being sorted accidentally spills material (such as maple syrup) on the conveying surface, the ridges of the Mark 2 Posisorter slat reduce the amount of material that falls into the center of the system and damages the sorting mechanism. Van den Goor Tr. 1480:3-1481:8.
- FF 169.** The ridges of the Mark 2 Posisorter slat also provide increased friction when the packages have soft bottoms. Van den Goor Tr. 1480:3-1481:8.
- FF 170.** If the front and rear side walls of the Mark 2 Posisorter diverter shoe were cut at the level of the conveying surface just below the top diverting portion of the shoe, as shown in RX-660C, the side walls of the shoe would flex and there would be inadequate alignment for the bearing surfaces. See Radcliffe Tr. 1168:4-1169:24; RX-660C.
- FF 171.** Radcliffe admitted on cross-examination that he never actually cut a Mark 2 Posisorter diverter shoe to see what would happen. See Radcliffe Tr. 1169:23-25.

- FF 172.** Van den Goor of Vanderlande performed the task of cutting the diverter shoe for illustrative purposes, and showed that when the Mark 2 Posisorter diverter shoe was cut at the level of the conveying surface as Radcliffe had surmised, the walls did not fall apart and the bottom portion of the shoe still had the ability to move back and forth on the slat. See van den Goor Tr. 1476:12-1477:23; Radcliffe Tr. 1170:1-10; RPX-1A; RPX-19.
- FF 173.** Van den Goor cut a second Mark 2 Posisorter diverter shoe just above the skids on the front and rear side walls. See van den Goor Tr. 1477:9-12; RPX-20. In this case, too, the lower portion of the cut-off shoe retained the ability to move back and forth on the slat. See van den Goor Tr. 1478:4-7; RPX-1A; RPX-20.
- FF 174.** In both instances, without the cut-off bottom part, the top part of both of van den Goor's cut-off Mark 2 Posisorter diverter shoes fell onto the slat, making contact with the slat. See van den Goor Tr. 1477:24-1478:3; 1478:8-10; RPX-1A; RPX-19; RPX-20.
- FF 175.** By contrast, the top piece did not fall onto the slat when the cuts were made on yet a third Mark 2 Posisorter diverter shoe at a point below the level of the skids. See van den Goor 1477:11-16, 1478:15-18; RPX-1A; RPX-21.
- FF 176.** The inner surface of the Mark 2 Posisorter shoe: (i) moves over or along the surface of the slat in a smooth, effortless manner without pivoting or rolling; and (ii) is two-dimensional.

- FF 177.** There is no dispute among the parties that the inner surface of the Mark 2 Posisorter shoe is “substantially continuous.”
- FF 178.** The inner surface of the Mark 2 Posisorter has spring-like projections off of the ends of the three inward protrusions from the inner surface that come in contact with the slat. See Radcliffe Tr. 851:23-853:22; Hoet Tr. 2035:20-2038:1; CPX-9; CPX-28.
- FF 179.** The inner surface of the Mark 2 Posisorter shoe extends on all sides and encircles the slat so as to cut off communication or retreat by any means other than sliding the shoe off the end of the slat.
- FF 180.** Vanderlande demonstrative exhibit RDX-44-3 faithfully represents the slat and shoe configuration of the Mark 2 Posisorter. RDX-44-3.
- FF 181.** According to Rapistan’s expert, Radcliffe, it is important to the invention of the ‘510 patent that the glide surface have substantially the same configuration as the outer surface of the slat in order to allow the slats to be placed closer together without interference between adjacent divert shoes. Radcliffe Tr. 847:6-14.
- FF 182.** It is also important structurally because the glide portion of the slat supports the glide surface better. Radcliffe Tr. 847:15-19.
- FF 183.** The glide surface of the diverter shoe disclosed in the ‘510 patent does not have exactly the same configuration as the outer configuration of the slat, and that there are in fact a series of protrusions and ribs that differ from the configuration of the slat. Radcliffe Tr. 847:20-848:3.

- FF 184.** According to Radcliffe, the inner surface of the Mark 2 Posisorter diverter shoe “follows relatively closely the outer configuration of the slat” although there are regions in which the configuration is “really quite different,” such as the ribs on the top surface of the shoe that are not reproduced on the outer portion of the slat. Radcliffe Tr. 848:4-21; RDX-44-3.
- FF 185.** Nevertheless, according to Radcliffe, as the claim requires only “substantially” the same configuration, it may vary “to a large degree.” Radcliffe Tr. 849:2-8; RDX-44-3.
- FF 186.** Radcliffe performed a calculation of the amount of deviation of the slat configuration from the configuration of the inner surface of the diverter shoe in the Mark 2 Posisorter, and found that the diagonal portion of the slat in the lower left corner (as shown in RDX-44-3 above) represents approximately 15 percent of the overall perimeter of the slat as measured from the centerline of the slat wall. Radcliffe Tr. 1200:17-25, 1201:10-24; RX-658C.
- FF 187.** Although this portion of the Mark 2 Posisorter shoe represents a substantial deviation in configuration between the shoe and the slat at that point, according to Radcliffe, the fact that it is under 15 percent means that the overall configuration is nevertheless “substantially the same.” Radcliffe Tr. 1201:25-1202:13.
- FF 188.** In performing this calculation, Radcliffe did not consider the fins on the upper inner surface of the diverter shoe to be configured differently from

the corresponding slat surface; if he had done so, it would have raised the foregoing percentage to as much as 30 percent. Radcliffe Tr. 1205:8-1206:9.

**FF 189.** Vanderlande's expert, Hoet, testified at trial that the shape of the Mark 2 Posisorter shoe is not substantially the same configuration as the shape of the slat. Hoet Tr. 1851:16-1857:2; 1994:8-18; RDX-18-2; RDX-18-3; RDX-43; RDX-44-2; RDX-44-3.

**FF 190.** Hoet pointed to a slat and shoe combination depicted in Figure 12 of the '912 patent, which is incorporated by reference into the '510 patent, showing no deviation at all in the configuration of the slat and the shoe. Hoet Tr. 1851:23-1852:17; RDX-18-2.

**FF 191.** In the slat and shoe configuration of Figure 10 of the '510 patent, there are areas where the shoe and slat surface deviate. Hoet Tr. 1853:4-11; RDX-43.

**FF 192.** In viewing the configuration of the slat and shoe of the Mark 2 Posisorter, Hoet pointed out that the upper inner surface of the shoe has fins sticking downward, which Hoet called "rake tines," and that the slat has ridges and drip edges that are not duplicated on the inner surface of the shoe, all of which he considered to be substantial deviations between the configurations of the slat and the shoe. Hoet Tr. 1855:1-14.

**FF 193.** Consistently with Radcliffe's testimony, Hoet further opined that the Mark 2 slat also has a slanted portion of the lower wall that deviates substantially

from the corresponding squared-off corner of the shoe. Hoet Tr. 1855:15-19.

**FF 194.** In considering whether Radcliffe's calculation that 15 percent of the outline of the slat deviated from the shoe at that location, Hoet deemed that amount to be substantial, and if the area of the fins on the top inner surface of the shoe were taken into account, the increase of this percentage to 30 percent was considered by Hoet to be substantial as well. Hoet Tr. 1856:4-1857:2.

**FF 195.** The credibility of Hoet's trial testimony was impeached by his deposition, in which he was asked the following question and gave the following answer:

Q: Addressing the shape of the inner surface on the shoe of Complainant's Exhibit B, is that inner surface, whatever you would call that overall inner surface, substantially the same configuration as the outer surface of the slat?

A: Substantially, it is. There are some differences shown in the lower-right forward corner, rear corner where the support part of the shoe deviates from the contour of the slat, and also in the upper part where it is parallel to the upper surface, there is some deviation from the surface of the slat. The rest of it is -- pretty much follows the contours of the slat.

Hoet Tr. 1994:19-1995:17, quoting from Hoet Dep. 197:21-198:11.

**FF 196.** Hoet disavowed this deposition testimony at trial, contending that he corrected his answer on the deposition errata sheet. See Hoet Tr. 1995:19-22.

**FF 197.** Hoet admitted at trial that the deposition testimony he gave was his opinion at the time, but that after studying a printout of the deposition transcript to

make corrections and after having an opportunity to study the Vanderlande shoe in more detail than he had done before, Hoet came to the conclusion that the Mark 2 Posisorter slat and shoe were not substantially the same configuration, that he had misspoken, and that he therefore offered the correction on his errata sheet. Hoet Tr. 1995:23-1997:2.

**FF 198.** As Radcliffe explained, there is an insubstantial difference between the configuration of the shoe and slat of the Mark 2 Posisorter and the claimed configuration of the glide surface of the shoe of the '510 patented invention that is "substantially the same" as the outer surface of the slat. Radcliffe Tr. 850:2-25. This is so because the glide surface of the Mark 2 shoe, like the invention, accomplishes the purpose of allowing the divert shoes to have clearance between one another while allowing the slats to be closely spaced, and also accomplishes the purpose of providing good structural support for the divert portion of the shoe over the top of the slat. Radcliffe Tr. 850:14-25.

**FF 199.** The slats of the Vanderlande Mark 2 Posisorter system are made of extruded aluminum. Radcliffe Tr. 860:25-861:15; Hoet Tr. 2070:12-13; CX-214 (at R21826).

**FF 200.** The Mark 2 Posisorter system is, as required by claim 13, "a conveying system having a longitudinally moving conveying surface defined by the uppermost ones of a plurality of slats connected in spaced relation with each other in an endless web."

- FF 201.** The Mark 2 Posisorter system has “a plurality of diverter shoes each moveably mounted on one of said slats for lateral movement with respect to said conveying surface.”
- FF 202.** As the Mark 2 Posisorter has “an outer surface having a planar upper portion” as required by claim 1 of the ‘510 patent, it therefore also satisfies the limitation found in claim 13 that requires “a wall having a generally planar upper . . . wall portion[ ].”
- FF 203.** When referring to the flat, “generally planar” appearance of the upper conveying surface of the slats of the Mark 2 Posisorter, Rapistan’s expert, Radcliffe, considered several slats together. See Radcliffe Tr. 746:9-20, 1194:14-22.
- FF 204.** Upon viewing several Mark 2 Posisorter slats upside down, Radcliffe admitted that the lower wall portion was not “generally planar” because “[t]here are some places along the bottom where there’s significant dips, if you will, in the surface formed if you put a bunch of [slats] together.” Radcliffe Tr. 1195:21-1197:1; RDX-78.
- FF 205.** Radcliffe’s opinion that the lower wall portion of the Mark 2 Posisorter was not “generally planar” when viewing several slats upside-down was based upon demonstrative exhibit RDX-78. See RDX-78.
- FF 206.** Despite this admission, Radcliffe explained his view that the lower wall portion of the Mark 2 slat is “generally planar” by pointing out that his definition of the lower wall is more restrictive than those of Vandcrlande



and the Staff, and by stating that “the function associated with being generally planar is focused on the strength of the single slat.” Radcliffe Tr. 1197:13-19.

**FF 207.** Unlike the lateral stabilizer protrusion of the slat of the ‘510 patent, the lateral stabilizer channel of the slat of the Mark 2 Posisorter does not begin and end in the same plane. Radcliffe Tr. 1199:14-1200:5; Hoet Tr. 1857:13-1858:18; RDX-79.

**FF 208.** In the embodiment of the invention depicted in the ‘510 patent, the lower wall portion of the slat deviates from “planar” by virtue of its “T-shaped projection 42” that acts as the lateral stabilizing means of the shoe-and-slat combination. See CX-1 (‘510 patent, col. 4:53-61; Fig. 3). That is not the same as the Mark 2 Posisorter slat, which deviates from “planar” in other significant respects, including principally its slanted wall and the projection of all of the lowermost front portion of the wall between the stabilizer channel and the front side wall well beyond what appears from the upside-down view of the slat to be the common plane of the lower wall portion. See RDX-78.

**FF 209.** No two portions of the lower wall of the Mark 2 Posisorter slat lie in the same plane. See Radcliffe Tr. 1199:4-1200:5; Hoet Tr. 1858:6-14, 1858:22-1859:1; RPX-1A.

- FF 210.** The lower wall of the Mark 2 Posisorter slat as Rapistan defines it exists in four separate planes formed by the lowermost forward part and the three walls of the stabilizer channel. See CDX-34, slide 7.
- FF 211.** The lower wall of the Mark 2 Posisorter slat includes inwardly projecting channels and an upwardly-sloping wall in addition to the thickened lowermost wall, and therefore does not concentrate material away from the center axis, but instead adds material closer to the center axis. See RPX-1 A.
- FF 212.** Radcliffe identifies as a “joining edge” on the Mark 2 Posisorter slat an item marked “B” on demonstrative exhibit RDX-81. See RDX-81.
- FF 213.** The “joining edge” on the Mark 2 Posisorter slat identified by Radcliffe is a small region of the wall itself, which, according to Radcliffe, has some thickness and therefore is not a mathematical point. See Radcliffe Tr. 1212:25-1213:8; RDX-81.
- FF 214.** The two surfaces in contact with one another that form the “bearing means” at the “joining edge” of the Mark 2 Posisorter shoe and slat, as identified by Radcliffe, consist of the vertical forward-facing surface of the slat in this region and the opposing vertical rearward-facing surface on the lateral stabilizer of the diverter shoe. See Radcliffe Tr. 879:14-20.
- FF 215.** Contact between these surfaces, according to Radcliffe, occurs entirely to one side of the small vertical wall segment and does not occur at the corner where that segment meets the slanted wall portion. See Radcliffe Tr. 1212:25-1213:8, 1213:15-22; RDX-81.

**FF 216.** Radcliffe conceded at trial that no contact occurs between the Mark 2 slat and shoe (i) at the upper front corner where the front side wall of the slat meets the upper wall portion (Radcliffe Tr. 1209:9-13); (ii) at the upper rear corner where the rear side wall of the slat meets the upper wall portion (Radcliffe Tr. 1209:14-15); (iii) at the lower front corner where the front side wall of the slat meets the “lower wall portion” (as all parties define that term in relation to the Mark 2) (Radcliffe Tr. 1209:16-18).

**FF 217.** Since Radcliffe’s definition of the “lower wall portion” does not include the part of the wall extending from the bottom of the rear stabilizer channel wall and slanting upward to the rear U-shaped channel, he therefore found no contact in that region either. Radcliffe Tr. 1209:19-23.

**FF 218.** During Radcliffe’s cross-examination regarding the differing reaction forces that are experienced in both the Mark 2 slat (as shown in Exhibit RDX-77) and the slat of the invention of the ‘510 patent (as shown in Exhibit RDX-76) as a result of rotations of the shoe along its vertical axis (i.e., axis B in Figure 8 of the ‘510 patent) and the lateral or “long” axis of the slat (i.e., axis C in Figure 8 of the ‘510 patent), it was demonstrated that rotation of the Mark 2 shoe about the long axis of the Mark 2 slat produced reaction forces at certain points in the slat (identified as reaction forces “A” through “D”) that corresponded to points in the slat of the ‘510 invention, and that rotation of the Mark 2 shoe about its own vertical axis produced reaction forces at different points in the slat (identified as reaction forces

“E” and “F”) that corresponded to points in the slot of the ‘510 invention. See CX-1 (‘510 patent, Fig. 8); Radcliffe Tr. 1351:2-1352:21; RDX-76; RDX-77.

**FF 219.** At the point in the Mark 2 slot where Rapistan contends that a “bearing means” is present, only reaction forces caused by rotations around the vertical axis (i.e., reaction forces “E” and “F”) were shown to exist. See Radcliffe Tr. 1351:2-1352:21; RDX-77.

**FF 220.** The Mark 2 Posisorter system has a lateral stabilizer consisting of a protrusion and a mating channel creating a pair of vertical walls that are on the lower part of the shoe and slot, which resist rotation about the vertical axis of the shoe, and have at least a shoe length-to-shoe width ratio of 6:1 that is better for stabilization than the 5:1 ratio of the embodiment disclosed in the ‘510 patent. See Radcliffe Tr. 1249:7-23; Hoet Tr. 2038:12-2039:6.

**FF 221.** The diverter shoes of the Vanderlande Mark 2 Posisorter system are made of a polymeric material. Radcliffe Tr. 940:2-12; Hoet Tr. 2070:9-11; CPX-9.

**FF 222.** In the Mark 2 Posisorter, the diverter shoe’s support portion is “defined by a multiplicity of joined wall segments having substantially the same thickness” as required by claim 22 of the ‘510 patent. CX-1 (‘510 patent, col. 7:37-39); Radcliffe Tr. 944:5-947:8; Hoet Tr. 2074:22-2075:3.

**FF 223.** The Mark 2 Posisorter system is, as required by claim 23, “a conveying system having a longitudinally moving conveying surface defined by the

uppermost ones of a plurality of slats connected in spaced relation with each other in an endless web.”

**FF 224.** The Mark 2 Posisorter system has “a plurality of diverter shoes each moveably mounted on one of said slats for lateral movement with respect to said conveying surface” as required by claim 23.

**FF 225.** The Mark 2 Posisorter system has, as required by claim 30, “a diverter shoe for use in a conveyor system having a longitudinally moving conveying surface defined by the uppermost ones of a plurality of slats connected in spaced relation with each other in an endless web.”

**FF 226.** The Mark 2 Posisorter has the element required by claim 30 of a “track means extending below said uppermost ones of said slats for engaging and imparting a lateral force to displace selected ones of said diverter shoes laterally with respect to said conveying surface.”

**FF 227.** The Mark 2 Posisorter has “a support portion,” and as construed herein, that element is the same as claim 30’s requirement of “a support member.”

**FF 228.** In the Mark 2 Posisorter shoe, the support member and diverting member are joined as a single unit by integral molding. See Radcliffe Tr. 1007:24-1008:3; Hoet 1998:23-1999:1.

**FF 229.** The diverter shoe of the Mark 2 Posisorter has “at least one substantially vertical diverting surface on a lateral end thereof” as required by claim 30.

**FF 230.** Rapistan’s expert, Radcliffe, testified that the Mark 2 shoe has three contiguous generally planar surfaces consisting of two lateral sloping

surfaces and one forward sloping surface that, like the embodiment described in the '510 patent, slope downward from an upper extent of the diverting surface laterally inward and longitudinally forward toward the direction of flow of the conveyor. Radcliffe Tr. 1008:4-1009:7; CDX-9 slides 11 and 12; CDX-34 slides 11 and 12. According to Radcliffe, the two lateral surfaces on either side of and contiguous to the forward surface have the claimed laterally inward and longitudinally forward slope corresponding to surfaces 82c and 82j of the embodiment shown in the '510 patent. Radcliffe Tr. 1008:11-19; CDX slide 11; CDX-34 slide 11.

**FF 231.** Vanderlande's expert, Hoet, prepared a series of demonstrative exhibits of both a Rapistan RS 200 shoe and a Vanderlande Mark 2 Posisorter shoe oriented in the same direction of conveyor flow and immersed in liquid (blackened water in the case of the Rapistan RS 200 shoe, milk in the case of the Mark 2 Posisorter shoe) in order to show the directions in which the liquid retreated from the slopes in question as each shoe emerges from the liquid. See Hoet Tr. 1866:24-1867:12; RDX-61-1 through RDX-61-8; RDX-62-1 through RDX-62-13.

**FF 232.** In order to more easily visualize the directionality of these sloping surfaces, Hoet referred to a physical Rapistan RS200 shoe as an exemplar of the preferred embodiment of the '510 patent because he recognized it to be a commercialization of that embodiment. See Hoet Tr. 2054:11-21.

- FF 233.** As each shoe emerged from its liquid, the boundary between the shoe's surface and the liquid formed a line that represents the slope of the surface at that line. Successive photographs were taken of that boundary as each shoe emerged from the liquid. See, e.g., RDX-61-4 (Rapistan RS 200 shoe); RDX-62-3 (Vanderlande Mark 2 Posisorter shoe).
- FF 234.** Successive lines showing the boundary of the shoe and the liquid as each shoe emerged were then traced from the photographs onto topographic views of each shoe, and, at trial, Rapistan's counsel drew circles denoted "A" and "B" around the portions of the two topographic views that corresponded to the slopes in question. See Hoet Tr. 2055:1-2058:15; CDX-42A; CDX-42B.
- FF 235.** As is evident from these two topographic views, the lines representing the slopes of the RS200 and Mark 2 shoe surfaces marked "A" are both angled laterally inward in the same direction toward the center of the shoe (i.e., from the upper right to the lower left), and the lines representing the slopes of the two shoe surfaces marked "B" are also both angled laterally inward in the same direction toward the center of the shoe (i.e., from the upper left to the lower right). CDX-42A; CDX-42B
- FF 236.** The intermediate surface of the Mark 2 shoe is level in the inward direction, just like the corresponding slope of surfaces 82d and 82k on the embodiment of the invention of the '510 patent, as exemplified in the

commercialized RS200 shoe. See CX-1 ('510 patent, Fig. 4); compare CPX-4 with CPX-28.

**FF 237.** The Mark 2 Posisorter system has, as required by claim 42, “a diverter shoe for use in a conveyor system having a longitudinally moving conveying surface defined by the uppermost ones of a plurality of slats connected in spaced relation with each other in an endless web.”

**FF 238.** The Mark 2 Posisorter diverter shoe’s support member “include[s] a follower portion adapted to be engaged by said track means and a base portion defined by said glide portion for mounting of said follower portion, said base portion defined by a plurality of said wall segments arranged in a honey-comb manner.” CX-1 ('510 patent, cols. 9:19-10:2); see Radcliffe Tr. 1028:4-13.

**FF 239.** Vanderlande has known of the '510 patent since November 1992. CX-218; van den Goor Tr. 1735:21-1736:21.

**FF 240.** Vanderlande was informed by Rapistan’s counsel, the Van Dyke firm, by letter dated June 19, 1998, prior to Vanderlande’s submission of its bid to UPS, that the Mark 2 Posisorter “would constitute an infringement of at least United States Patent 5,127,510 if made, used, sold or offered for sale or imported to the United States of America.” RX-426.

**FF 241.** Vandcrlande’s president, Rein van der Lande, postponed responding to this letter because of the ongoing bid process with UPS. Van der Lande Tr. 1614:12-18, 1642:12-1643:3.



**FF 242.** It was not until after the UPS bid was awarded to Vanderlande in August 1998 that Rein van der Lande responded to Rapistan asserting that the Mark 2 Posisorter did not infringe the '510 patent. Van der Lande Tr. 1660:1-14.

**FF 243.** [

] Bobilin Tr. 1295:4-11; Martin Tr. 1905:9-15.

**FF 244.** The Mark 2 Posisorter shoe and slat are the only components that constitute the subject matter of the '510 patent. See CX-1 ('510 patent).

**FF 245.** [

] Brouckman Tr. 221:16-23; Van Alten Tr.

2184:22-2185:7.

**FF 246.** The original versions of the RS200 slat and shoe are exemplified by physical exhibits CPX-31 (left-handed diverter shoe) and CPX-32 (slat). Van Alten Tr. 2184:22-2185:7; CPX-31; CPX-32.

**FF 247.** The current versions of the RS200 slat and shoe that are manufactured in Michigan and marketed by Rapistan are exemplified by physical exhibits CPX-21 (slat) and CPX-22 (bi-directional diverter shoe). Woltjer Tr. 316:5-15, 317:16-20; CPX-21; CPX-22.

**FF 248.** Rapistan's expert, Radcliffe, testified that the current version of the RS200 made by Rapistan practices claim 1 of the '510 patent. Radcliffe Tr. 859:4-860:24; CPX-21; CPX-22.

- FF 249.** Radcliffe also testified that the current version of the RS200 practices claim 23 of the '510 patent as well. Radcliffe Tr. 953:3-954:12; CPX-21; CPX-22.
- FF 250.** There have been some changes made to the RS200 slat and shoe since it was originally introduced. Woltjer Tr. 317:21-318:3; Radcliffe Tr. 733:17-734:19; CPX-21; CPX-22; CPX-31; CPX-32.
- FF 251.** In 1993, an internal web was added to the interior of the slat to absorb noise and the cutouts on either side of the lateral stabilizer projection that gave it a "T"-shape were eliminated. Woltjer Tr. 318:7-319:3; Radcliffe Tr. 734:15-19, 1241:7-11 and 1241:25-1242:3.
- FF 252.** In 1995, the enlarged radius corners at the front and rear of the upper conveying surface of the slat were flattened out. Woltjer Tr. 319:4-15; Radcliffe 1241:12-18.
- FF 253.** Also, the center support rib in the middle of the upper glide surface of the shoe was reduced so that its contact with the upper conveying surface of the slat was eliminated. Woltjer Tr. 319:16-11; Radcliffe 734:8-11 and 1241:19-24.
- FF 254.** In connection with the set of concept drawings of the Mark 1 Posisorter that were given by Hans Bodewes of Vanderlande to '510 co-inventor Bernard Woltjer of Rapistan on March 7, 1990, the first concept drawing showed an overview of the Mark 1 in action, and the second concept drawing showed a cross-section of the Mark 1 shoe and slat. CX-415C.

- FF 255.** At the time that Woltjer and Cotter of Rapistan received these concept drawings from Bodewes of Vanderlande, Rapistan was already in the middle of designing the RS200 sortation system, which had begun with discussions in 1988 and had proceeded to documentation by at least as early as July 24, 1989. Woltjer Tr. 340:24-345:3; 440:9-14; Cotter Tr. 558:1-559:2; CX-303C; CX-307C; CX-308C; CDX-26.
- FF 256.** In its preliminary plans around that date, Rapistan envisioned creating a sortation system using a diverter shoe made of molded plastic and a carrier slat made of extruded aluminum or composite material. Cotter Tr. 560:8-561:5; 670:20-671:20; CX-308C.
- FF 257.** On or about August 3, 1989, Rapistan prepared a concept drawing for a trapezoidal slat and shoe prototype. Cotter Tr. 561:6-23; CX-310C.
- FF 258.** Around September 8, 1989, Rapistan created a production drawing of that prototype shoe. Woltjer Tr. 345:4-12, 357:15-21; CX-321C.
- FF 259.** A production drawing of the prototype slat was created on or about October 20, 1989. Cotter Tr. 563:19-25; CX-339C.
- FF 260.** A physical prototype shoe and slat of the design was prepared by Rapistan around December 1989. Woltjer Tr. 357:22-358:10; CPX-13; CPX-14.
- FF 261.** By December 1989, according to Woltjer, the only two claimed elements of the '510 patent that were not yet part of Rapistan's trapezoidal prototype design were the "lateral stabilizing means" of claims 17 and 23, and the "plurality of contiguous, generally planar surfaces sloping downward from

- an upper extent of said diverting surface laterally inward and longitudinally forward or rearward” of claim 30. Woltjer Tr. 360:13-361:18; CX-321C.
- FF 262.** Rapistan tested the trapezoidal prototype slat and shoe design in January 1990, with less than satisfactory results. Woltjer Tr. 362:14-24; Cotter Tr. 559:3-13; CPX-13; CPX-14; CDX-26.
- FF 263.** Those results led to a redesign, shown on drawings having a so-called “V.A. date” of February 15, 1990 standing for the date on which the manufacturing department agreed upon the final design. Woltjer Tr. 363:18-365:22; Cotter Tr. 559:13-16; CX-403C; CX-422C.
- FF 264.** By the following March, Rapistan had confirmed that this new design worked for its intended purpose. Cotter Tr. 657:8-658:15.
- FF 265.** By March 16, 1990, Rapistan released its final design for product manufacturing. Woltjer Tr. 365:23-367:10; CX-861C.
- FF 266.** This design ultimately became the final RS200 diverter shoe support portion and slat, and also became the preferred embodiment disclosed in the ‘510 patent. Woltjer Tr. 439:22-440:2.
- FF 267.** The drawings of the redesign show the “lateral stabilizing means of claims 17 and 23 that Woltjer said was not present in the earlier prototype design, but do not show the “plurality of contiguous, generally planar surfaces” of claim 30. CX-403C; CX-422C.

- FF 268.** Those surfaces were worked out by co-inventor Curtis LeMay, but a definitive date for his work was not established by Rapistan during the trial. Cotter Tr. 567:20-568:16; CX655C; CX-656C.
- FF 269.** Figure 15 of the Lauzon '247 patent and Figure 9 of the Yu '677 patent show cross-sections of the two prior-art references. RX-577; RX-602.
- FF 270.** As required by claim 1 of the '510 patent, both the Lauzon '247 and Yu '677 patent references are conveying systems "having a longitudinally moving conveying surface" made up of the top set of a series of slats connected at opposite ends by a pair of endless chains. Hoet Tr. 1873:20-21, 1881:20-23; RX-577 (Lauzon '247 patent, col. 6:56-62; Figs. 1-11 and 17); RX-602 (Yu '677 patent, col. 2:63-3:10 and Figs. 1-2).
- FF 271.** Both Lauzon '247 and Yu '677 have the required "plurality of diverter shoes . . . for lateral movement with respect to the conveying surface," but only in the Lauzon '247 reference is each shoe "moveably mounted on one of said slats" (emphasis added). Hoet Tr. 1881:24-25; Radcliffe Tr. 1389:14-23; CDX-27 at 5; RX-577 (Lauzon '247 patent, Fig. 15); RX-602 (Yu '677 patent col. 3:13-17 and Figs. 1, 2 and 9).
- FF 272.** Both systems have "track means for imparting a lateral force to move said diverter shoes laterally to displace product positioned on said conveying surface." Hoet Tr. 1873:24-1874:2, 1882:1-2; RX-577 (Lauzon '247 patent, col. 7:62-13:37); RX-602 (Yu '677 patent, col. 3:18-24, 5:38-49, and Figs. 1-2, 5 and 10-14).

- FF 273.** The slats of the Yu '677 system are "defined by a wall formed as a right cylinder." Hoet Tr. 1882:3-4; RX-602 (Yu '677 patent, Fig. 9).
- FF 274.** The slats of the Lauzon '247 system are not closed walls, but rather have a "C"-shaped cross-section (i.e., open at the bottom) and therefore are not "right cylinders." Radcliffe Tr. 2207:17-21; CDX-27 at 4; RX-577 (Lauzon '247 patent, col. 7:39-40 and Fig. 15).
- FF 275.** The walls of the slats of the Lauzon '247 system include "an outer surface having a planar upper portion defining said conveying surface," but the walls of the slats of the Yu '677 system, being circular cylinders, do not have a planar upper portion. Hoet Tr. 1874:16-20; Radcliffe Tr. 2214:18-2215:12; CDX-27 at 5; RX-577 (Lauzon '247 patent, Fig. 15); RX-602 (Yu '677 system, Fig. 9).
- FF 276.** Both the Lauzon '247 and Yu '677 systems have "a support portion." Hoet Tr. 1877:10-16; 1882:5-6; RX-577 (Lauzon '247 patent, Fig. 15); RX-602 (Yu '677 patent, Fig. 9).
- FF 277.** In neither Lauzon '247 nor Yu '677 does the support portion include "a substantially continuous glide surface surrounding said wall, said glide surface having substantially the same configuration as said outer surface of said slat." Instead, the shoe of the Lauzon '247 reference is supported by rolling bearings and does not have a glide surface that glides along the slat or surrounds the slat. Radcliffe Tr. 2207:17-2208:2; CDX-27 at 4; RX-577 (Lauzon '247 patent, Fig. 15).

**FF 278.** The shoe of the Yu '677 reference has a glide surface, but it is not continuous, does not surround the slat, and does not have substantially the same configuration as the outer surface of the slat. Radcliffe Tr. 2214:18-2216:19; CDX-27 at 5; RX-602 (Yu '677 patent, Fig. 9).

**FF 279.** In connection with the element of dependent claim 4 "wherein each of said slats is formed by extrusion," neither the Lauzon '247 patent nor the Yu '677 patent indicate that their slats are so made, but there is undisputed evidence in the record that extrusion would have resulted in a cheaper manufacturing process. Cotter Tr. 534:20-535:6; Hoet Tr. 1875:24-1876:3, 1879:23-24.

**FF 280.** Hoet stated cross-examination, "if you do remove parts from any sorter, whether it's the RS 200 shoe or slat or the Mark 2 shoe and slat, you destroy its operation. I mean, that's common. You take it apart, it won't work anymore." Hoet Tr. 2091:16-20.

**FF 281.** [

] Brouckman Tr. 223:16-224:25;

CDX-11C; CDX-12C.

**FF 282.** [

]

Brouckman Tr. 224:2-25; CDX-11C; CDX-12C.

**FF 283.** [

] Brouckman Tr. 272:23-276:6; CDX-11C; CDX-12C.

**FF 284.** The RS200T system has a tube-type conveyor that is built within the framework of the RS200, using the frame, drive components and switch components of the RS200. Woltjer Tr. 355:10-20.

**FF 285.** [

] Woltjer Tr. 355:21-356:11.

**FF 286.** Dale Manzel, a director of distribution centers and material handling systems for K-Mart Corporation, testified that K-Mart purchased an RS200 system in April 1991 for installation at K-Mart's Ocala, Florida distribution facility. Manzel Tr. 289:1-6; 290:16-291:2; 293:5-7.

**FF 287.** According to Manzel, the RS200 demonstrated increased throughput and product conveyability over its predecessor that K-Mart also utilized, the Rapistan PS140 sortation system. Manzel Tr. 291:3-24.

**FF 288.** In terms of "conveyability," Manzel explained that the old PS140 was a tube sorter that had gaps between the rollers, whereas the RS200 is a fairly flat surface. Manzel Tr. 291:18-24.



- FF 289.** In the former, products could fall into the gaps between the rollers and cause jams and blowups, whereas the RS200 with its flat conveying surface would keep sorting under such conditions. Manzel Tr. 291:25-294:1.
- FF 290.** After purchasing an RS200 system for the Ocala facility, K-Mart purchased additional RS200s. Manzel Tr. 294:2-7.
- FF 291.** French published patent application 2,388,737 (“the CML ‘737 reference”), entitled “Facility for transferring and sorting miscellaneous objects,” was published on November 24, 1978, and named as applicant Francesco Canziani. RX-220.
- FF 292.** What Rapistan and Vanderlande agree is a physical counterpart of the embodiment disclosed in the CML ‘737 reference was introduced into evidence at trial as exhibit RPX-9. Hoet Tr. 2080:24-2081:1.
- FF 293.** The CML ‘737 reference was published in France more than one year prior to the date of the application for the ‘510 patent in the United States. See 35 U.S.C. § 102(b); RX-220.
- FF 294.** Figures 7, 8 and 9 of the CML ‘737 reference show the combination of slats (items 30 and 31) and shoes (item 7) disclosed in this reference. RX-220.
- FF 295.** The CML ‘737 reference discloses in the text that the shoes are connected to carriages that “reduce the friction against” sliding rods underneath the slats. RX-220 (CML ‘737 reference at 2388737).
- FF 296.** Although the reference does not specify how the carriages “reduce the friction” against the “sliding rods,” the physical counterpart of the CML

'737 reference uses rollers for this purpose. Radcliffe Tr. 2210:3-14; RPX-9.

**FF 297.** As required by claim 1 of the '510 patent, the CML '737 reference discloses "a conveying system having a longitudinally moving conveying surface defined by the uppermost ones of a plurality of slats connected at opposite ends in spaced relation with each other to a pair of endless chains." Hoet Tr. 1878:17-21; RX-220 (CML '737 reference, Figs. 1-3).

**FF 298.** The CML '737 reference has the required "plurality of diverter shoes . . . for lateral movement with respect to the conveying surface." Hoet Tr. 1878:22-24; RX-220 (CML '737 reference, Figs. 1-3 and 7-9).

**FF 299.** Each shoe of the CML '737 reference is "moveably mounted on one of said slats," namely, the middle of a series of three slats.

**FF 300.** The CML '737 reference also has "track means for imparting a lateral force to move said diverter shoes laterally to displace product positioned on said conveying surface." Hoet Tr. 1878:25-1879:2; RX-220 (CML '737 reference at 4-6 and Figs. 5 and 6).

**FF 301.** The limitation of claim 1 requiring that each of the slats must be "defined by a wall formed as a right cylinder" is not present in the CML '737 device. Radcliffe Tr. 2211:4-14; CDX-27 at 7; RX-220 (CML '737 reference Fig. 7).

**FF 302.** A "right cylinder" as construed herein is a surface that intersects a perpendicular plane at a curve consisting of a generally closed loop, which

is not the case with the slats of the CML '737 device. RX-220 (CML '737 reference Fig. 7).

**FF 303.** Each slat of the CML '737 device has "an outer surface having a planar upper portion defining said conveying surface." Hoet Tr. 1879:6-9; RX-220 (CML '737 reference, Figs. 7 and 9).

**FF 304.** However, this outer surface is not included in "a wall formed as a right cylinder," as explained above, and therefore does not satisfy claim 1 in this respect. Radcliffe Tr. 2211:12-14; CDX-27 at 7.

**FF 305.** The diverter shoe of the CML '737 reference has "a support portion" as claim 1 requires. Hoet Tr. 1879:10-12; RX-220 (CML '737 reference, Figs. 7-9).

**FF 306.** However, the support portion of the CML '737 device does not include "a substantially continuous glide surface surrounding said wall, said glide surface having substantially the same configuration as said outer surface of said slat" as claim 1 requires and as construed herein. Instead, the shoe of the CML '737 reference is supported by roller bearings and does not have a glide surface that glides along the slat or surrounds the slat. Radcliffe Tr. 2211:20-2212:7; CDX-27 at 7; RX-220 (CML '737 reference, Figs. 4 and 7-8); RPX-9.

**FF 307.** The stamped slats of the CML '737 device are expensive compared to extruded slats. Hoet Tr. 1879:23-24.

**FF 308.** Figure 4 of the Brouwer '347 patent shows a cross-section of that prior art device. RX-333.

**FF 309.** The Lauzon '247, Yu '677 and Brouwer '347 patent references all satisfy the requirement in claim 13 that they are "conveying system[s] having a longitudinally moving conveying surface defined by the uppermost ones of a plurality of slats connected in spaced relation with each other in an endless web." Hoet Tr. 1873:20-21, 1879:25-1880:3,1881:20-23; RX-333 (Brouwer '347 patent, col. 3:30-31 and Fig. 1); RX-577 (Lauzon '247 patent, col. 6:56-62; Figs. 1-11 and 17); RX-602 (Yu '677 patent, col. 2:63-3:10 and Figs. 1-2).

**FF 310.** All three references have the required "plurality of diverter shoes . . . for lateral movement with respect to the conveying surface," but only in the Lauzon '247 reference is each shoe "moveably mounted on one of said slats" (emphasis added). Hoet Tr. 1881:24-25; Radcliffe Tr. 2217:9-2219:12, 1389:14-23; CDX-27 at 5 and 6; RX-333 (Brouwer '347 patent, Fig. 4); RX-577 (Lauzon '247 patent, Fig. 15); RX-602 (Yu '677 patent col. 3:13-17 and Figs. 1, 2 and 9).

**FF 311.** All three systems have "track means engaging said diverter shoes for imparting a lateral force to move said diverter shoes laterally to displace product positioned on said conveying surface." Hoet Tr. 1873:24-1874:2, 1880:6-8, 1882:1-2; RX-333 (Brouwer '347 patent, col. 3:31-51 and Figs.

1 and 2); RX-577 (Lauzon '247 patent, col. 7:62-13:37); RX-602 (Yu '677 patent, col. 3:18-24, 5:38-49, and Figs. 1-2, 5 and 10-14).

**FF 312.** The slat of the Lauzon '247 patent has a wall having a "generally planar" upper portion as required by claim 13, but, having a "C"-shaped cross-section (i.e., open at the bottom), does not have any lower wall at all, much less a "generally planar" lower wall. Radcliffe Tr. 2207:17-21; RX-577 (Lauzon '247 patent, col. 7:39-40; Fig. 15).

**FF 313.** The slats of the Brouwer '347 and Yu '677 patents, having circular tubes, have no "generally planar" upper or lower wall portions at all. Radcliffe Tr. 2214:18-2215:15, 2217:9-24; CDX-27 at 5 and 6; RX-333 (Brouwer '347 patent, Fig. 4); RX-602 (Yu '677 system, Fig. 9).

**FF 314.** The upper wall portion of the slat of the Lauzon '247 patent is "joined by side wall portions defining joining edges between each of said wall portions." Hoet Tr. 1876:8-11; RX-577 (Lauzon '247 patent, Fig. 15).

**FF 315.** The Brouwer '347 and Yu '677 patents, having circular tubes, have neither side walls nor joining edges. Radcliffe Tr. 2214:18-2215:17, 2217:9-2218:1; CDX-27 at 5 and 6; RX-333 (Brouwer '347 patent, Fig. 4); RX-602 (Yu '677 system, Fig. 9).

**FF 316.** In all three references, the diverter shoes have "a support portion." Hoet Tr. 1877:10-16, 1880:19-20, 1882:5-6; RX-333 (Brouwer '347 patent, Fig. 4); RX-577 (Lauzon '247 patent, Fig. 15); RX-602 (Yu '677 patent, Fig. 9).

- FF 317.** In neither the Lauzon '247 device nor the Yu '677 device, however, does the support portion include "a glide surface surrounding said wall." Instead, the shoe of the Lauzon '247 reference is supported by rolling bearings and does not have a glide surface that glides along the slat or surrounds the slat. Radcliffe Tr. 2207:17-2208:2; CDX-27 at 4; RX-577 (Lauzon '247 patent, Fig. 15).
- FF 318.** The shoe of the Yu '677 reference has a glide surface, but it does not surround the slat. Radcliffe Tr. 2214:18-2216:19; CDX-27 at 5; RX-602 (Yu '677 patent, Fig. 9).
- FF 319.** On the other hand, the shoe of the Brouwer '347 patent has one glide surface that surrounds the wall of the middle one of the three slats on which it glides. Hoet Tr. 1880:21-23; Radcliffe Tr. 2218:14; RX-333 ('Brouwer '347 patent, Fig. 4).
- FF 320.** None of the three references has the element in claim 13 of a "bearing means defining a bearing between at least one of said joining edges of each of said slats and an engaging portion of said glide surface of the corresponding one of said diverter shoes." The Lauzon '247 patent, having no glide surface, has no such bearing at any joining edge. Radcliffe Tr. 2207:12-2208:9; CDX-27 at 4; RX-577 (Lauzon '247 patent, Fig. 15).
- FF 321.** Each of the Brouwer '347 and Yu '677 patents, having multiple circular tubes for slats that have no joining edges, has no such bearing at the glide

surface. Radcliffe Tr. 2214:18-2216:7, 2216:20-2218:23; CDX-27 at 4 and 5; RX-333 (Brouwer '347 patent, Fig. 4); RX-602 (Yu '677 patent, Fig. 9).

**FF 322.** In connection with the element in dependent claim 17 of “means defining lateral stabilizing means” that can “resist[ ] vertical-axis reaction-force-couples,” the evidence of record does not sufficiently show whether the Lauzon '247 device or the Yu '677 device have such means. The Brouwer '347 patent does not have structure that is identical to that disclosed in the '510 patent consisting of a set of vertical surfaces associated with a single slat and a single shoe. Radcliffe Tr. 2217:9-2219:1; CDX-27 at 6; RX-333 (Brouwer '347 patent, Fig. 4).

**FF 323.** However, the Brouwer '347 patent has equivalent structure that performs the same function as the disclosed structure of the '510 patent. Hoet Tr. 1881:6-8; Radcliffe Tr. 1133:2-1136:3; RX-330 (Brouwer '347 patent, col. 6:67-7:7 and Fig. 4); RDX-74.

**FF 324.** In connection with the element in dependent claim 20 “wherein said support portion is molded of a polymeric material,” the shoe of the Lauzon '247 patent is made of metal. Hoet Tr. 1877:4-5.

**FF 325.** However, the Yu '677 device satisfies this element in that it includes a body base 24 that is a molded polymer. Hoet Tr. 1883:7-9; RX-602 (Yu '677 patent, col. 4:4-8 and Fig. 9, item 24).

**FF 326.** The Brouwer '347 patent also satisfies this element in that the shoe consists of a “body 45” having an “upper portion 46” and a “lower portion 47” that

overall is “preferably made from a rigid plastic material.” Hoet Tr. 1881:9-11; RX-333 (Brouwer ‘347 patent, cols. 4:31-32, 5:4-5 and Fig. 4).

**FF 327.** Plastics were well-known and used in the sortation industry at the time of the invention of the ‘510 patent, and a person of ordinary skill would have been motivated to use plastics to make a diverter shoe. Hoet Tr. 1871:7-1872:4, 2079:8-15; RDX-92.

**FF 328.** In connection with the element in dependent claim 22 “wherein said support portion is defined by a multiplicity of joined wall segments having substantially the same thickness,” the shoe of the Lauzon ‘247 patent meets this limitation. RX-577 (Lauzon ‘247 patent, Fig. 15).

**FF 329.** The support portions of the shoes of the Brouwer ‘347 patent and the Yu ‘677 patent do not meet this limitation of claim 22. Radcliffe Tr. 2214:18-2216:19, 2217:9-2219:12; CDX-27 at 5 and 6; RX-333 (Brouwer ‘347 patent, Fig. 4); RX-602 (Yu ‘677 patent, Fig. 9).

**FF 330.** The Brouwer ‘347 patent was issued more than one year prior to the date of the application for the ‘510 patent in the United States. See 35 U.S.C. § 102(b); RX-333 (Brouwer ‘347 patent, first page).

**FF 331.** The diverting shoe of the Brouwer ‘347 patent has no adjacent surfaces that slope downward and inward. RX-333 (Brouwer ‘347 patent Figs. 5 and 9).

**FF 332.** The Mark 1 Posisorter drawings that were conveyed to Rapistan by Vanderlande on March 7, 1990 suggest nothing about “a plurality of contiguous, generally planar surfaces sloping downward from an upper



extent of said diverting surface laterally inward and longitudinally forward or rearward.” Radcliffe Tr. 2219:16-2220:4, 2222:5-2222:12; CDX-27 at 3; RX-30.

**FF 333.** The Mark 1 Posisorter lacks the element of claim 30 consisting of a “support member having a glide portion including means defining a glide surface adapted to glide along one of said slats,” because the diverter shoe of the Mark 1 Posisorter uses rollers to contact the slat, not a glide surface. Hoet Tr. 2033:11-2034:1; Radcliffe Tr. 2221:17-20; CDX-27 at 3, RX-30.

**FF 334.** David Cotter testified at trial as follows:

Q Now, every design that you worked on had contact on the top conveying surface; correct?

A That’s correct.

Q And you never considered any design that didn’t contact the top conveying surface; correct?

A That is correct.

Cotter Tr. 660:5-10.

**FF 335.** At his deposition, Bernard Woltjer testified as follows:

Q Before filing this patent, did you think of any variation of your invention which did not have a glide surface that had contact on the top?

A No.

JX-24C (Woltjer Dep. 176:13-16)

**FF 336.** At trial, Woltjer testified as follows:

Q And during that entire effort over that year, you never considered any variation of your invention that did not have a glide surface which contacted the top of the slat; correct?

A I don't know that we didn't, but it's not in the record. So what we have is what we have.

Q There's no record of you considering any other design other than one that had contact on the top of the conveying surface?

A Right. I didn't keep all the napkins from the cafeteria, so I don't know exactly all the possibilities we covered, but this is the evidence.

Woltjer Tr. 441:21-442:7

**FF 337.** Co-inventor Curtis LeMay was involved with the design of the diverting member, not the support member or the glide surface of the support member. JX-8C (LeMay Dep. 16:6-17:12, 22:16-23:1, 30:14-18, 71:5-8).

**FF 338.** At trial, van den Goor admitted that he is not a co-inventor of the '510 patent. Van den Goor Tr. 1736:22-1737:9.

**FF 339.** Rein van der Lande, Vanderlandc's former president, agreed with van den Goor's assessment that he was not a co-inventor of the '510 patent. Van der Lande Tr. 1675:5-14.

**FF 340.** [

] JX-19C (van der Wielen

Dep. 13:20-14:11).

**FF 341.** [

] JX-19C (van der Wielen Dep. 56:15-20, 57:16-24, 58:1-4,60:6-61:2, 121:1-24); CX-154C; CX-511C.

**FF 342.** [

] JX-19C (van der Wielen Dep. 71:23-72:3).

**FF 343.** In November 1989, Bernard Woltjer visited Vanderlande at its headquarters in Veghel, The Netherlands. Woltjer Tr. 369:12-370:2.

**FF 344.** Woltjer met with van den Goor on November 8, 1989, and at that meeting Woltjer received a copy of the van der Wielen memorandum. JX-24C (Woltjer Dep. 55:19-24); Woltjer Tr. 376:23-377:12; CX-511C.

**FF 345.** In one of the questions of the November 8 memo, van der Wielen memo asked Rapistan for an opinion about two proposed shoe shapes. CX-511C. Underneath that question are four drawings of top and side views of the proposed shapes that van der Wielen drew on the memo. JX-19C (van der Wielen Dep. 60:6-61:2); CX-511C.

**FF 346.** [

]

JX-19C (van der Wielen Dep. 64:2-13).

**FF 347.** [

]

JX-19C (van der Wielen Dep. 122:11-123:2, 123:11-21).

FF 348. [

]JX-19C

(van der Wielen Dep. 123:24-124:13, 125:2-9, 125:14-19, RX-468C.

FF 349. Woltjer prepared a written response to van der Wielen's memo. Woltjer Tr. 380:23-381:12; RX-430C.

FF 350. In response to the question about the two proposed shoe shapes, Woltjer's written reply stated as follows:

When the shoe first impacts the product it will over rotate and the rear corner will become caught in any gap between the shoes, so at the end of the divert angle where it goes straight, it gives the corner of these cartons a flick which spins them a little. The best shapes [sic] shoe would provide a continuous surface when several are pushing product.

RX-430C.

FF 351. At trial, Woltjer explained his response as follows:

Well, in responding to that question, "what do you think of shapes like that," in this business you really cannot tell a lot unless you have experience doing it or you observed it or you test it, and not having tested that sort of thing I kind of responded in a generic way and kind of gave them guidelines for how a design ought to be made, as opposed to a direct answer to whether of those two shapes, would be one better than the other or one more appropriate than the other.

Woltjer Tr. 383:4-12.

FF 352. When Woltjer returned to Rapistan from his trip to Vanderlande in The Netherlands, he shared with others at Rapistan the information that he

learned from Vanderlande. Woltjer Tr. 431:9-15; JX-24C (Woltjer Dep. 80:3-7).

**FF 353.** Those with whom he shared such information probably included the other inventors of the '510 patent, Cotter and LeMay. Woltjer Tr. 431:16-21; JX-24C (Woltjer Dep. 80:21-81:3).

**FF 354.** Curtis LeMay is credited with designing the shape of the sloping surfaces of the top of the diverter shoe of the '510 patent. Cotter Tr. 522:14-23.

**FF 355.** According to LeMay's deposition testimony, Cotter told LeMay in the fall of 1989 to work on that design, and of the need for the shoe top to be able to relieve jams that could happen on a sorter. JX-8C (LeMay Dep. 17:3-12).

**FF 356.** According to LeMay, Cotter gave two suggestions on the design: "that it was the direction and movement of the sorter shoe relative to the cartons that were being conveyed;" and that, to be safe, the backside of the shoe should be tapered in addition to the front side "just in case there was some kind of strange happenstance from where the sorter jammed from behind rather than from ahead." JX-8C (LeMay Dep. 18:6-17).

**FF 357.** In order to design the shape of the shoe top, LeMay made clay models of proposed shapes with the objective of minimizing the slope of the faces on the shoe, thereby minimizing the potential for jamming. JX-8C (LeMay Dep. 19:11-20:3).

- FF 358.** According to LeMay, Cotter suggested minimizing the slopes as a result of Woltjer's request that the shoe cap should alleviate any jamming. JX-8C (LeMay Dep. 46:17-18:7).
- FF 359.** The clay model shapes were input into a 3-dimensional computer-aided design unit, or "CAD." JX-8C (LeMay Dep. 20:4-7).
- FF 360.** A "production intent" drawing was generated by the CAD having a date of March 17, 1990. JX-8C (LeMay Dep. 50:4-19); RX-337C.
- FF 361.** LeMay testified that, other than his memory, he had no other way to show when he completed his work on the shoe top. JX-8C (LeMay Dep. 51:12-18).
- FF 362.** In a document dated July 26, 1989, Rapistan created a "preliminary design specification" for a "high rate sorter" that eventually became the RS200 sortation system. Woltjer Tr. 341:24-342:8; CX-308C.
- FF 363.** In that specification, one of Rapistan's stated objectives was that the design should be "contoured to prevent 'pinch' type jams." Woltjer Tr. 342:9-22; CX-308C.
- FF 364.** [

] CX-217C at 3-4.

**FF 365.** During the period of the License Agreement between Rapistan and Vanderlande, there was “an enormous amount of cooperation” between Rapistan and Vanderlande, with the parties working together on several projects. Van der Lande Tr. 1605:13-20.

**FF 366.** These cooperative efforts included Rapistan’s assisting Vanderlande in securing business from Compaq Computer in Holland in 1992, in which Vanderlande installed Mark 2 Posisorters and other sortation equipment at Compaq’s Dutch computer facility. Van der Lande Tr. 1606:1-18 and 21-25.

**FF 367.** On October 31, 1991, Rapistan filed an application for a European patent corresponding to the U.S. ‘510 patent, which was published on May 6, 1992. RX-126; RX-482C.

**FF 368.** The application was granted and issued on March 1, 1995 as the EP ‘150 patent. RX-130.

**FF 369.** [

] Metros Tr. 896:15-897:7; Bobilin Tr. 1281:20–22.

**FF 370.** [ ] Metros Tr. 897:6-7; JX-10C (Metros Dep.) at 117:3-6; Bobilin Tr. 1281:23-24.



**FF 371.** [

] Martin Tr. 1899:6-9.

**FF 372.** Notwithstanding that directly competitive activity, Rapistan never sued Vanderlande in Europe on the EP '150 patent. Metros Tr. 897:8-898:6; 915:11-13.

**FF 373.** [

] Bobilin Tr. 1283:18-

21; Brouckman Tr. 252:12-18; van der Lande Tr. 1617:4-13.

**FF 374.** [

] Van der Lande Tr. 1616:19-23.

**FF 375.** [

] Martin Tr. 1899:15-21; Edwards Tr. 1438:5-23, 1439:2-4.

**FF 376.** The June 19, 1998 letter from Terry Linn of the Van Dyke firm to Vanderlande arrived at Vanderlande approximately one month before Vanderlande submitted its bid to UPS. Van der Lande Tr. 1636:14-18.

**FF 377.** Vanderlande viewed this letter as a threat to sue it for infringement and a form of intimidation during the bidding phase of the Hub 2000 project. Van der Lande Tr. 1640:6-13.

**FF 378.** However, Vanderlande postponed a response to this letter for the duration of the bid process. Van der Lande Tr. 1642:18-1643:3.

**FF 379.** [

] JX-10C (Metros Dep.) at 100:14-19; JX-1C (Beasley Dep.) at 82:1-8; JX-3C (Brouckman Dep.) at 59:11-24; Bobilin Tr. 1295:4-8; Martin Tr. 1905:9-15.

**FF 380.** In August 1998, UPS awarded Vanderlande the Hub 2000 contract, which was signed in October 1998. Van der Lande Tr. 1616:9-12; CX-212C-A.

**FF 381.** [

]JX-1C (Beasley Dep.) at 87:8-16, 88:1-4; RX-99C; Martin Tr. 1902:2-22.

**FF 382.** At that meeting, UPS told Rapistan's attendees that Vanderlande would use the Mark 2 Posisorter for Hub 2000. RX-99C; JX-1C (Beasley Dep.) at 88:13-15.

**FF 383.** Later in 1998, during discussions among James Brouckman (Rapistan's executive vice-president), John Raab (Rapistan's vice-president of marketing) and Earl Beasley (one of Rapistan's employees on the Hub 2000 bid project), Raab told Brouckman that Vanderlande was "allegedly going to use the Posisorter, which would then infringe upon the patent rights of the RS 200 and that if sales wanted to take any kind of action, this was —

this would be an appropriate time to take action.” JX-13 (Raab Dep.) at 68:3-8; 68:10-11.

**FF 384.** On December 8, 1998, Brouckman of Rapistan wrote a letter to Rein van der Lande, then the president of Vanderlande, to propose that Vanderlande buy the RS200 from Rapistan for use at the Hub 2000 facility. CX-583C.

**FF 385.** The letter was reviewed and commented upon by Rapistan’s counsel, Burkhardt, before being sent. JX-26C (Burkhart Dep.) at 110:6-19.

**FF 386.** In his letter, Brouckman characterized his offer to Vanderlande as follows:

This is a win-win situation for everybody. UPS gets proven technology they have already accepted with local US support, you get out from under the potential of a patent infringement on this product, and we get some business.

CX-583C.

**FF 387.** At trial, Rein van der Lande characterized his reaction to this letter at the time as “a threat and also somewhat an opportunistic letter.” Van der Lande Tr. 1619:14-18.

**FF 388.** On January 29, 1999, Rein van der Lande wrote back to Brouckman rejecting the Rapistan offer. CX-584C.

**FF 389.** In the letter, van der Lande also acknowledged receipt of the earlier letter from Linn of the Van Dyke firm, and further stated as follows:

From the beginning we were of the opinion that we do not infringe the patents referred to in the above-mentioned letter and this opinion has in the meantime been confirmed by US counsel’s opinion.

Taking the above into account we do not see a reason to discuss your offer to conclude a cooperation for the Hub 2000 project of UPS.

CX-584C.

**FF 390.** Van der Lande testified at trial that after his letter was sent in January 1999, “[w]e didn’t hear back from anyone, and therefore, we believed that Brouckman and his law firm agreed with our position. And as a matter of fact, two months after sending the letter and not having heard anything from Rapistan, or the attorneys, I called our counsel, Freshfields in Amsterdam, and asked them to close our files.” Van der Lande Tr. 1621:23-1622:5.

**FF 391.** Pete Metros, the president and CEO of Rapistan, testified at trial about Rapistan’s actions after the UPS contract for Hub 2000 was awarded to Vanderlande. According to Metros, when the Brouckman letter was sent in December 1998, he was aware of the possibility that Vanderlande would import Mark 2 Posisorters for the project, but was uncertain as to whether Vanderlande would do so because “they had an option” to use other products. Metros Tr. 902:13-18, 903:11-14.

**FF 392.** Metros testified that he was still uncertain whether Vanderlande would use the Mark 2 Posisorter for the Hub 2000 project even after Rapistan received Vanderlande’s January 1999 rejection of the Linn and Brouckman letters. Metros Tr. 905:22-907:5.

**FF 393.** Metros also testified that Rapistan did not inform UPS of its infringement position on the Mark 2 Posisorter because it would be unethical “to get the customer in the middle of this” and would be “negative selling.” Metros Tr. 909:14-910:3.

**FF 394.** Metros also stated, in answer to a question as to whether he would always authorize a lawsuit for patent infringement if advised by his employees that he could do so, as follows:

Gentlemen, lawsuits cost a lot of money. I think every case has to stand on its own merits relative to pursuing a lawsuit. I would tell you that, as a matter of our philosophy, that we protect our patented products, but I would tell you, in all cases, we would not do that.

Metros Tr. 918:17-25.

**FF 395.** At approximately the same time as Vanderlande was closing its legal file on the Linn and Brouckman letters, by a contract dated May 3, 1999, Rapistan, under its former name Mannesmann Dematic Rapistan Corp., entered into an agreement with UPS to install a system for the sortation of “irregular-sized” packages at the Hub 2000 facility (the “irregulars system” or “irregulars project”). RX-313C.

**FF 396.** The irregulars system deals with irregular-shaped packages or parcels that cannot be handled on the normal transport system. Van Helmond Tr. 1317:19-21.

**FF 397.** The irregulars system is more akin to a traditional airport baggage-handling system, and uses such equipment because of the size of the cargo. JX-7C (Langen Dep.) at 22:12-20.

**FF 398.** The main system installed by Vanderlande and the irregulars system physically go “one over the other” at Hub 2000. Brouckman Tr. 265:5-7; RPX-17.

**FF 399.** [

] Martin Tr. 1904:1-4; RPX-17.

**FF 400.** The controls of the main system and the irregulars system share electronic information between them. JX-9C (Litchfield Dep.) at 52:3-53:24; RX-247.

**FF 401.** Karl-Heinz Langen, a member of the board of directors of Mannesmann Dematic, submitted the bid to UPS and handled the layout work. JX-7C (Langen Dep.) at 7:21-23, 13:9-12, 31:1-3, 11-17; RX-313C at R030191.

**FF 402.** According to Rapistan, the contract was placed in the name of Rapistan at the time merely as a legal formality because the German affiliate did not operate in the United States. See JX-9C (Litchfield Dep.) at 90:24-92:19.

**FF 403.** Langen testified at his deposition that the Offenbach-based German team did not communicate with Grand Rapids-based Rapistan regarding the project. See JX-7C (Langen Dep.) at 21:22-22:7, 28:18-21, 32:25-33:2, 56:7-57:19.

**FF 404.** [

] Martin Tr.

1909:7-14.

**FF 405.** Moreover, Mannesmann Dematic's project manager on the irregulars project, David Litchfield, testified at his deposition that as of 2000, when he was placed on the payroll of Rapistan, he was not uncomfortable with the arrangement because the relationship of Rapistan to Mannesmann Dematic was "close enough" in his view. See JX-9C (Litchfield Dep.) at 100:6-18.

**FF 406.** Litchfield also testified that he communicated with a Rapistan employee as his contact with the purchasing department for dealing with his U.S. subcontractors on the project. JX-9C (Litchfield Dep.) at 102:7-19.

**FF 407.** Litchfield also termed the relationship between Rapistan and Mannesmann Dematic on the irregulars project as a "subcontract" from Rapistan to Mannesmann Dematic's German affiliate. JX-9C (Litchfield Dep.) at 108:8-109:7.

**FF 408.** Henk van Helmond, Vanderlande's contract manager on the UPS Hub 2000 project, testified at trial that Vanderlande and Rapistan had to interface with each other as part of their contractual obligations to UPS because of limited space available in the building site. Van Helmond Tr. 1320:17-1321:9.

**FF 409.** Van Helmond further testified that he met several times with Litchfield of Rapistan and had meetings with Rapistan personnel both at Vanderlande's headquarters in Veghel, The Netherlands, during the design phase of the project as well as on-site at Louisville, Kentucky during installation, the latter occurring on a weekly basis. Van Helmond Tr. 1321:10-1322:15.

**FF 410.** [

] Martín Tr. 1904:5-1905:8.

**FF 411.** Litchfield of Rapistan testified at his deposition that he did not meet with any Vanderlande people during his trips to Louisville in 1999, but that he did have one visit to Vanderlande at Veghel in mid-September 1999 together with Achim Planz, an employee of Mannesmann's airport department in Germany, and Wayne Speir of UPS, for the purpose of finding a path for the irregular system through some complicated areas where Vanderlande had "an awful lot of equipment" and to "check[ ] layouts and interfaces so that the conveyor systems did not clash with each other." JX-9C (Litchfield Dep.) at 27:11-22, 28:24-29:5, 30:10-22.



- FF 412.** According to Litchfield, UPS chaired the meeting to resolve the problem, “[a]nd the only way was to get our system designer there and the Vanderlande system designer, so they could literally sit next to each other” and move conveyors on a drawing “to make sure they miss” each other. JX-9C (Litchfield Dep.) at 32:2-12.
- FF 413.** They worked with a composite layout drawing that showed the conveyor path for each of the two parties but lacked details, and they tried to integrate the two conveyors to make sure that both could be installed. JX-9C (Litchfield Dep.) at 33:20-34:14.
- FF 414.** The first Vanderlande Mark 2 Posisorters arrived at the Hub 2000 facility in September or October 1999. Van Helmond Tr. 1342:24-1343:2.
- FF 415.** Vanderlande installed the first Mark 2 Posisorter at the Hub 2000 facility commencing in November 1999. Van Helmond Tr. 1314:22-25.
- FF 416.** Posisorter parts were kept on the floor of the work area in full view of anyone working on the project and were never concealed. Van Helmond Tr. 1316:19-1317:7; 1320:7-16.
- FF 417.** Langen of Rapistan saw Posisorter parts there when he first visited the site in February 2000, although he was not aware at the time that they were Vanderlande Posisorter parts. JX-7C (Langen Dep.) at 40:24-41:22.
- FF 418.** The performance of the Hub 2000 project was divided into several phases: engineering, procurement, installation, testing, commissioning, and integration. Van Helmond Tr. 1313:10-14.

- FF 419.** The engineering phase began in October 1998 when Vanderlande obtained the contract, and ended in 2000. Van Helmond Tr. 1313:15-24.
- FF 420.** In October 1999, during the engineering phase, Vanderlande first gained access to the Hub 2000 facility. Van Helmond Tr. 1314:8-11.
- FF 421.** In January 2000, the German team from Rapistan arrived at Hub 2000 to commence work on the irregulars system. Van Helmond Tr. 1319:17-19.
- FF 422.** The next phase, procurement, lasted until July 2001. Van Helmond Tr. 1313:25-1314:7.
- FF 423.** The next phase, installation, was implemented in three overlapping phases: Phase I, started in November 1999 and completed in March 2001, called for 24,000 packages sorted per hour and cost over \$130 million; Phase II, started in March 2000 and completed in August 2001, called for 32,000 packages sorted per hour and cost over \$90 million; and Phase III, started in October 2000 and completed in July 2002, called for 144,000 packages sorted per hour and cost over \$200 million. RIB 148; Van Helmond Tr. 1313:5-9.
- FF 424.** Currently, there are 96 Vanderlande Mark 2 Posisorters installed at the Hub 2000 facility. Van Helmond Tr. 1314:12-14.
- FF 425.** On October 3, 2000, Rapistan's lawyers visited the Hub 2000 site to inspect Posisorters, and they provided a written opinion to Rapistan related to their inspection later the same month. JX-26C (Burkhart Dep.) at 98:17-99:5; RX-482C.

**FF 426.** [

] **Bobilin Tr.**

1295:4-11.

**FF 427.** [

]

**RX-504C; Bobilin Tr. 1298:8-1299:10.**

**FF 428.** Rapistan has been contesting Vanderlande's European patent claims relating to the Mark 2 Posisorter and the RS200 through interference proceedings for several years. CRB 148 n.58; van den Goor Tr. 1737:10-1739:24.

**FF 429.** At trial, Rein van der Lande testified as follows:

Q Now, at the time Vanderlande was putting its UPS bid together in 1998, you were – pretty well aware of [the ‘510 patent] at that time, were you not?

A Most likely, but we did not consider that that was an issue also, because we were competing or had been competing with Rapistan on many occasions, many – in several occasions in Europe, including the UPS facility in Frankfurt.

Van der Lande Tr. 1635:22-1636:4.

FF 430. Hermann Miedel, Vanderlande’s former president of its United States operations, testified in his deposition in response to a question of whether there was a “concern on the part of Vanderlande that a possible infringement action by Rapistan would interfere with the Hub-2K project,” that “we installed these sorters in front of Rapistan Dematic in Frankfurt two years ago and they had nothing against it.” See JX-11C (Miedel Dep.) at 114:7-19.

FF 431. Concerning Vanderlande’s receipt of the Linn warning letter in June 1998 while it was preparing its bid for Hub 2000, van der Lande testified as follows:

Q [reading the Linn letter] . . . “Be advised that the system installed by Vanderlande at United Parcel Service in Frankfurt, Germany would constitute an infringement of at least United States patent 5,127,510 if made, used, sold or offered for sale in or imported to the United States.”

You fully understood what Mr. Linn was telling you there, did you not?

A Yes, I understood. But if I may, Mr. Van Dyke, Mr. Linn wrote this letter, of course upon instigation of Rapistan, in a period in which we, the two companies, were competing for the largest material handling project ever in the world. And I would

think that, as part of that bidding process, an intimidating letter would be one of the weapons which Rapistan would use, in the hope that they could scare us off.

Q Could you just read -- I'm sorry.

A And in addition, you can write or Mr. Linn can write that providing something similar to what we provided in Frankfurt would be an infringement of the U.S. patent '510, but then when I read that, I also wonder how come he never wrote me a letter of similar nature after I received a contract for the UPS facility in Europe, because we used the same product and we would be infringing on the same patent for that matter.

Van der Lande Tr. 1639:24-1640:22.

**FF 432.** At trial, van der Lande testified that he had worked in Vanderlande, which his father had founded, since 1971, had been CEO of the company from January 1981 until April 2002, had a bachelor's degree in mechanical engineering and a master's degree in business administration from Northeastern University in Boston, and had received an award from the Queen of The Netherlands for his contributions "to society in general or to industry, export or employment for the region in particular." Van der Lande Tr. 1595:1-1596:21.

**FF 433.** Rein van der Lande characterized the opinion of counsel as one that "wasn't an opinion favorable to us, it was an opinion which confirmed our position, which is quite different." Van der Lande Tr. 1669:18-24.

**FF 434.** Van der Lande testified that he did not know Terence J. Linn, the attorney who authored the June 1998 letter from the Van Dyke firm. See van der Lande Tr. 1637:17-1638:3. He admitted, however, that he knew who the

Van Dyke firm was, that he was personally familiar with Daniel Van Dyke, and that Linn's letter had to have been authorized by that firm in order to be sent to Vanderlande. See van der Lande Tr. 1638:4-22.

**FF 435.** Rapistan's German team from Offenbach made no mention of patent infringement issues when it came to Vanderlande's headquarters in Veghel, The Netherlands to work jointly with UPS on a problem at the Hub 2000 project. See van der Lande Tr. 1626:5-17; 1681:14-1682:8.

**FF 436.** Rein van der Lande testified at trial as follows:

**Q** In what way does this [January 29, 1999 rejection] letter constitute any reliance by Vanderlande with respect to Rapistan activity?

**A** At the time of writing the letter, it did not, not on the 29th of January. In the period thereafter, of course it did.

**Q** So the lack of a reply had a bearing, did impact your behavior; is that correct?

**A** Yes, because I clearly confirmed to Mr. Brouckman that we would go ahead with importing the product, the alleged product, as referred to in Mr. Linn's letter, and that, in our opinion, there is no infringement whatsoever, even after having received U.S. and Dutch counsel opinion.

Van der Lande Tr. 1662:1-12.

**FF 437.** Rein van der Lande testified that "the fact that [Rapistan] didn't do anything until – in fact, never ever did anything, meant we went ahead in the execution of the contract." Van der Lande Tr. 1648:18-20.

**FF 438.** [

]RX-449C-

A at 18; van der Lande Tr. 1624:11-1626:16.

FF 439. [

] Martin Tr. 1906:1-5.

FF 440. [

]

Van der Lande Tr. 1611:5-17.

FF 441. [

] Chevalier Tr. 1417:19-25.

FF 442. [

] Chevalier Tr. 1417:19-25.

**FF 443. [**

**] Van der Lande Tr. 1627:13-16.**

**FF 444. [**

**] See Bobilin Tr. 1298-99; RX-504C.**

**FF 445. [**

**] JX-4C (Chevalier Dep. 24:16-18, 44:4-45:23, 60:2-8); JX-12C  
(Pastorino Dep. 40:2-25).**



## CONCLUSIONS OF LAW

1. The Commission has subject matter jurisdiction in this investigation.
2. The Commission has personal jurisdiction over Respondent Vanderlande.
3. The Vanderlande Mark 2 Posisorter sortation system infringes claims 1 and 4 of U.S. Letters Patent No. 5,127,510 in violation of 35 U.S.C. § 271(a).
4. The Vanderlande Mark 2 Posisorter sortation system does not infringe claims 13, 17, 20, 22, 23, 27, 29, 30, 33, 35, 42, 43, or 45 of U.S. Letters Patent No. 5,127,510.
5. Vanderlande's importation and sale of the Mark 2 Posisorter sortation system in the United States constitutes contributory infringement and induced infringement of U.S. Letters Patent No. 5,127,510 in violation of 35 U.S.C. § 271(b) and (c).
6. An industry in the United States exists with respect to the Rapistan RS200 sortation system that is protected by U.S. Letters Patent No. 5,127,510 as required by 19 U.S.C. §§ 1337(a)(2) and (3).
7. Claims 1 and 4 of U.S. Letters Patent No. 5,127,510 are not invalid under 35 U.S.C. § 102(f) based on the Mark 1 Posisorter.
8. Claims 1 and 4 of U.S. Letters Patent No. 5,127,510 are not invalid under 35 U.S.C. § 103(a) based on the Mark 1 Posisorter.
9. Claims 1 and 4 of U.S. Letters Patent No. 5,127,510 are not invalid under 35 U.S.C. § 103(a) based on U.S. Letters Patent No. 3,361,247 and U.S. Letters Patent No. 4,884,677.

10. Claim 1 of U.S. Letters Patent No. 5,127,510 is not invalid under 35 U.S.C. § 102(b) based on French Patent Publication 2,388,737.
11. Claim 4 of U.S. Letters Patent No. 5,127,510 is not invalid under 35 U.S.C. § 103(a) based on French Patent Publication 2,388,737.
12. Claims 13 and 17 of U.S. Letters Patent No. 5,127,510 are not invalid under 35 U.S.C. § 102(f) based on the Mark 1 Posisorter.
13. Claims 13 and 17 of U.S. Letters Patent No. 5,127,510 are not invalid under 35 U.S.C. § 103(a) based on the Mark 1 Posisorter.
14. Claims 13, 17, 20 and 22 of U.S. Letters Patent No. 5,127,510 are not invalid under 35 U.S.C. § 103(a) based on U.S. Letters Patent No. 3,361,247 and either U.S. Letters Patent No. 4,884,677 or U.S. Letters Patent No. 4,738,347.
15. Claims 20 and 22 of U.S. Letters Patent No. 5,127,510 are not invalid under 35 U.S.C. § 103(a) based on the Mark 1 Posisorter and either U.S. Letters Patent No. 4,884,677 or U.S. Letters Patent No. 4,738,347.
16. Claim 23 of U.S. Letters Patent No. 5,127,510 is not invalid under 35 U.S.C. § 102(f) based on the Mark 1 Posisorter.
17. Claim 23 of U.S. Letters Patent No. 5,127,510 is not invalid under 35 U.S.C. § 103(a) based on the Mark 1 Posisorter.
18. Claims 27 and 29 of U.S. Letters Patent No. 5,127,510 are not invalid under 35 U.S.C. § 103(a) based on the Mark 1 Posisorter and either U.S. Letters Patent No. 4,884,677 or U.S. Letters Patent No. 4,738,347.

19. Claims 23, 27 and 29 of U.S. Letters Patent No. 5,127,510 are not invalid under 35 U.S.C. § 103(a) based on U.S. Letters Patent No. 3,361,247 and either U.S. Letters Patent No. 4,884,677 or U.S. Letters Patent No. 4,738,347.
20. Claims 30 and 33 of U.S. Letters Patent No. 5,127,510 are not invalid under 35 U.S.C. § 102(b) based on U.S. Letters Patent No. 4,738,347.
21. Claim 30 of U.S. Letters Patent No. 5,127,510 is not invalid under 35 U.S.C. § 102(f) based on the Mark 1 Posisorter.
22. Claim 30 of U.S. Letters Patent No. 5,127,510 is not invalid under 35 U.S.C. § 103(a) based on the Mark 1 Posisorter.
23. Claims 30, 33 and 35 of U.S. Letters Patent No. 5,127,510 are not invalid under 35 U.S.C. § 103(a) based on U.S. Letters Patent No. 3,361,247 and U.S. Letters Patent No. 4,884,677.
24. Claims 33 and 35 of U.S. Letters Patent No. 5,127,510 are not invalid under 35 U.S.C. § 103(a) based on the Mark 1 Posisorter and either U.S. Letters Patent No. 4,884,677 or U.S. Letters Patent No. 4,738,247.
25. Claim 42 of U.S. Letters Patent No. 5,127,510 is not invalid under 35 U.S.C. § 102(f) based on the Mark 1 Posisorter.
26. Claims 42, 43 and 45 of U.S. Letters Patent No. 5,127,510 are not invalid under 35 U.S.C. § 103(a) based on the Mark 1 Posisorter.
27. Claims 42, 43 and 45 of U.S. Letters Patent No. 5,127,510 are not invalid under 35 U.S.C. § 103(a) based on U.S. Letters Patent No. 3,361,247 and U.S. Letters Patent No. 4,884,677.

28. Claims 1, 4, 13, 17, 20, 22, 23, 27, 29, 30, 33, 35, 42, 43, and 45 of U.S. Letters Patent No. 5,127,510 are not invalid under 35 U.S.C. §§ 101, 102(f), or 112 for claiming a glide surface broader than the glide surface invented by the applicants.
29. Claims 1, 4, 13, 17, 20, 22, 23, 27, 29, 30, 33, 35, 42, 43, and 45 of U.S. Letters Patent No. 5,127,510 are not invalid under 35 U.S.C. § 112 for not disclosing the structure that corresponds to the “track means” element of the asserted claims.
30. Neither Jacobus van den Goor nor Ton van der Wielen are omitted inventors from U.S. Letters Patent No. 5,127,510.
31. Vanderlande is not a co-owner of U.S. Letters Patent No. 5,127,510.
32. Rapistan is not barred by the doctrine of equitable estoppel from asserting infringement of U.S. Letters Patent No. 5,127,510 against Vanderlande.
33. There is a violation of 19 U.S.C. § 1337(a)(1)(B) in the importation into the United States, the sale for importation, and the sale within the United States after importation of certain sortation systems, parts thereof, and products containing same manufactured and sold by Vanderlande Industries Nederland BV and Vanderlande Industries, Inc.

## INITIAL DETERMINATION

Based on the foregoing opinion, findings of fact, conclusions of law, the evidence, and the record as a whole, and having considered all pleadings and arguments, including the proposed findings of fact and conclusions of law, it is the Administrative Law Judge's INITIAL DETERMINATION that a violation of Section 337 of the Tariff Act of 1930, as amended, exists in the importation into the United States, sale for importation, or the sale within the United States after importation of certain sortation systems, parts thereof, and products containing same by reason of infringement of claims 1 and 4 of U.S. Letters Patent No. 5,127,510, and that a domestic industry exists in the United States that practices the patent at issue.

The Administrative Law Judge hereby CERTIFIES to the Commission this Initial Determination, together with the record of the hearing in this investigation consisting of the following:

- The transcript of the trial, with appropriate corrections as may hereafter be ordered by the Administrative Law Judge; and further,
- The exhibits accepted into evidence in this investigation as listed in the attached exhibit lists.

Pursuant to 19 C.F.R. § 210.42(h), this Initial Determination shall become the determination of the Commission unless a party files a petition for review pursuant to 19 C.F.R. § 210.43(a) or the Commission, pursuant to 19 C.F.R. § 210.44, orders on its own motion a review of the Initial Determination or certain issues therein.

## RECOMMENDED DETERMINATION ON REMEDY AND BOND

Pursuant to Commission Rules 210.36(a) and 210.42(a)(1)(ii), the Administrative Law Judge is to consider evidence and argument on the issues of remedy and bonding, and issue a recommended determination thereon.

### I. Remedy

#### A. General or Limited Exclusion Order

Section 337(d)(2) authorizes the Commission to issue a general exclusion order only if it determines that --

(A) a general exclusion from entry of articles is necessary to prevent circumvention of an exclusion order limited to products of named persons; or

(B) there is a pattern of violation of this section and it is difficult to identify the source of infringing products.

19 U.S.C. § 1337(d)(2); 19 C.F.R. § 210.50(c). Rapistan seeks only a limited exclusion order directed solely against the accused products of Vanderlande.

#### B. Scope of Exclusion From Entry

##### 1. "Entry for Consumption"

The Commission's authority under Section 337 to issue orders excluding unfair imports from entry into the United States extends to all forms of Customs "entry," not only to entry for consumption in the United States. Certain Devices for Connecting Computers Via Telephone Lines, Inv. No. 337-TA-360, U.S.I.T.C. Pub. No. 2843, Commission Opinion at 9, 1994 WL 932382 (U.S.I.T.C., December 1994). This authority, however, is generally applied by the Commission "in measured

fashion,” and the Commission issues “only such relief as is adequate to redress the harm caused by the prohibited imports.” *Id.* In this regard, the type of entry that adversely affects complainants in most cases is entry for consumption, and an exclusion order covering other types of entry, such as entry for transshipment in bond through the United States, normally is not issued absent a showing by the complainant of a need for such an order. *Id.* at 9-10.

In the present case, Rapistan has not made any showing of the need for an exclusion order that extends beyond “entry for consumption.”

## **2. Replacement Parts**

In this case, the products at issue are the slat and shoe components of an overall sortation system. These parts are imported in component form and are installed in sortation systems such as Hub 2000 in Louisville, Kentucky that are unique to each system site. Thus, there is no recognizable physical difference between slats and shoes that are imported as part of an original installation of a sortation system in the United States and slats and shoes that are imported as spare parts.

[

] See Bobilin Tr.

1298-99; RX-504C; FF 444. [

]

If the Commission determines that Vanderlande Mark 2 Posisorter slats and shoes being imported as spare parts should be excluded to the same extent as slats and shoes being imported for an original installation, it should exempt spare parts being imported exclusively for use at the UPS Hub 2000 facility altogether.

**C. Certification Provision**

Limited exclusion orders may contain a “certification” provision whereby a respondent may import goods by providing to the Customs Service a written certification that the imported products in question are not covered by the asserted claims of the patents at issue. Such provisions facilitate Customs’ administration of the order by eliminating the often difficult task of determining how a product was made by examining its contents or appearance. Similar certification provisions have been included in previous exclusion orders, particularly when respondents imported both infringing and non-infringing products. See, e.g., Certain Condensers, Parts Thereof, and Products Containing Same, Inv. No. 337-TA-334 (Remand Proceeding), Commission Opinion at 39, 1997 WL 599891 (U.S.I.T.C., September 10, 1997); Certain Minoxidil Powders, Salts, and Compositions for Use in Hair Treatment, Inv. No. 337-TA-267 (1988); Certain Curable Fluoroelastomer Compositions and Precursors Thereof, Inv. No. 337-TA-364, U.S.I.T.C. Pub. No. 2890 (May 8, 1995).

If the Commission determines that Vanderlande Mark 2 Posisorter slats and shoes being imported exclusively as spare parts for use at the UPS Hub 2000 facility are to be specifically exempted from the exclusion order, then as an aid to the Customs Service in distinguishing between excluded slats and shoes and UPS Hub



2000 spare parts, Vanderlande could be required to certify that any importation of Mark 2 Posisorter slats and shoes are for use exclusively as replacement parts for the UPS Hub 2000 facility in Louisville, Kentucky.

**D. Cease and Desist Order**

Cease and desist orders are warranted primarily when the respondent maintains a commercially significant inventory of the accused products in the United States. See Certain Crystalline Cefadroxil Monohydrate, 15 U.S.P.Q.2d 1263, 1277-79 (U.S.I.T.C. 1990). Here, Rapistan has shown that [

](Chevalier Dep. 24:16-18, 44:4-45:23, 60:2-8); JX-12C (Pastorino Dep. 40:2-25); **FF 445; FF 59-61 and 65** (First Stipulation Nos. 59-61 and 65). However, as both Vanderlande and the Staff note in opposing a cease and desist order, Rapistan has failed to demonstrate that Vanderlande maintains any inventory in the United States, and in the absence of such inventory, the Commission's practice is to refrain from issuing a cease and desist order. RIB 159; RRB 117; SIB 99; SRB 31. Accordingly, a cease and desist order is unwarranted and is not recommended.

**II. Bond During Presidential Review Period**

If the Commission enters an exclusion order or cease and desist order, parties may continue to import and sell their products during the pendency of the Presidential review under a bond in an amount determined by the Commission to be "sufficient to protect the Complainants from any injury." 19 U.S.C. § 1337(e); 19 C.F.R. § 210.50(a)(3).

---

The Commission frequently sets the bond by attempting to eliminate the difference in sales prices between the patented domestic product and the infringing product. See, e.g., *Microsphere Adhesives*, supra, Commission Opinion at 24. However, in the absence of reliable price information, the Commission has used other methods to determine an appropriate bond. For example, where a price comparison is unworkable, the Commission has determined that a bond of 100 percent is appropriate. See, e.g., *Certain Variable Speed Wind Turbines and Components Thereof*, Inv. No. 337-TA-376, U.S.I.T.C. Pub. No. 3003, Commission Opinion at 27-28 and 40, 1996 WL 1056330 (U.S.I.T.C., September 23, 1996). In other instances where a direct comparison between a patentee's product and the accused product was not possible, the Commission has set the bond at a reasonable royalty rate. See, e.g., *Certain Digital Satellite System (DSS) Receivers and Components Thereof*, Inv. No. 337-TA-392, U.S.I.T.C. Pub. No. 3418, Initial and Recommended Determinations at 245, vacated on other grounds, Commission Determination (May 13, 1999), 2001 WL 535427 (U.S.I.T.C., October 20, 1997).

In this instance, Rapistan argues that the appropriate bond is 100% of either the entered value of the infringing sortation systems and/or components thereof, or Vanderlande's 2002 offering price for the infringing sortation system and/or components thereof, whichever is higher. CIB 183; CRB 167. The Staff agrees, pointing out that the products at issue are generally sold as subsystems of larger, custom-designed conveying systems and that it is therefore impractical to make price comparisons between the accused products and Rapistan's domestic product. SIB

100. Vanderlande contends that no bond is warranted, particularly since Rapistan has indicated that it does not intend to enforce any remedial orders against Vanderlande products imported for use in the UPS facility. RIB 160; RRB 118-19.

As the Staff points out, the Mark 2 Posisorter slats and shoes at issue are generally sold as part of larger, custom-designed conveying systems and price comparisons are, therefore, impractical. Accordingly, a bond of 100% of the entered value of Mark 2 Posisorter systems and components thereof is warranted and recommended. However, it is the Customs Service, not Rapistan, that enforces the bonding provision of an exclusion order. Accordingly, Rapistan cannot excuse Vanderlande from posting a bond for sortation systems and components thereof that are destined for the UPS Hub 2000 facility at Louisville, Kentucky. An exception from the bonding provision must be carved out for that purpose. Accordingly, an exception from a 100% bond for imports destined for the UPS Hub 2000 facility at Louisville, Kentucky is warranted and recommended.

Within seven days of the date of this document, each party shall submit to the office of the Administrative Law Judge a statement as to whether or not it seeks to have any portion of this document deleted from the public version. The parties' submissions may be made by facsimile and/or hard copy by the aforementioned date.

Any party seeking to have any portion of this document deleted from the public version thereof must submit to this office a copy of this document with red brackets indicating any portion asserted to contain confidential business information. The parties' submissions concerning the public version of this document need not be filed with the Commission Secretary.

**SO ORDERED.**

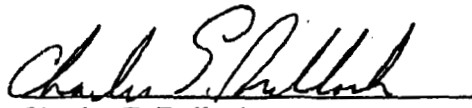
A handwritten signature in cursive script, appearing to read "Charles E. Bullock", written over a horizontal line.

Charles E. Bullock  
Administrative Law Judge

**APPENDIX OF EXHIBIT LISTS**

**IN THE MATTER OF CERTAIN SORTATION  
SYSTEMS, PARTS THEREOF, AND  
PRODUCTS CONTAINING SAME**

**INV. NO. 337-TA-460**

**CERTIFICATE OF SERVICE**

I, Marilyn R. Abbott, hereby certify that the attached ORDER was served upon, David H. Hollander, Jr., Commission Investigative Attorney, and the following parties via first class mail and air mail where necessary on November 13, 2002.



Marilyn R. Abbott, Secretary  
U.S. International Trade Commission  
500 E Street, S.W., Room 112A  
Washington, D.C. 20436

**FOR COMPLAINANTS RAPISTAN SYSTEMS ADVERTISING CORP., AND  
SIEMENS DEMATIC CORP.:**

V. James Adduci, II, Esq.

Tom M. Schaumberg, Esq.

Robert A. Westerlund, Esq.

Steven E. Adkins, Esq.

Michael G. McManus, Esq.

Sarah E. Hamblin, Esq.

**ADDUCI, MASTRIANI & SCHAUMBERG, L.L.P.**

1200 Seventeenth Street, N.W.

Fifth Floor

Washington, D.C. 20036

Daniel Van Dyke, Esq.

Terence J. Linn, Esq.

**VAN DYKE, GARDNER, LINN & BURKHART, LLP**

2851 Charlevoix Drive S.E.

Grand Rapids, Michigan 49588-8695

**IN THE MATTER OF CERTAIN SORTATION  
SYSTEMS, PARTS THEREOF, AND  
PRODUCTS CONTAINING SAME**

**INV. NO. 337-TA-460**

R. Brent Hatcher, Jr., Esq.  
W. Scott Creasman, Esq.  
Leslie B. Zacks, Esq.  
**POWELL, GOLDSTEIN, FRAZER & MURPHY LLP**  
191 Peachtree Street, N. E.  
Sixteen Floor  
Atlanta, Georgia 30303

Jerry B. Blackstock, Esq.  
J. Wilcox Dunn, III, Esq.  
Thomas J. Mazziotti, Esq.  
Joel K. Gerber, Esq.  
**HUNTON & WILLIAMS**  
Bank of America Plaza  
600 Peachtree Street, N.E.  
Suite 4100  
Atlanta, GA 30308

Robert R. Merhige, Jr., Esq.  
**HUNTON & WILLIAMS**  
Riverfront Plaza, East Tower  
951 East Byrd Street  
Richmond, VA 23219-4074

**FOR RESPONDENTS VANDERLANDE INDUSTRIES NEDERLAND BV AND  
VANDERLANDE INDUSTRIES INC.:**

John M. DiMatteo, Esq.  
Scott B. Howard, Esq.  
**PATTERSON, BELKNAP, WEBB & TYLER, LLP**  
1133 Avenue of the Americas  
New York, New York 10036-6710

Cecilia H. Gonzalez, Esq.  
Bert C. Reiser, Esq.  
Margaret D. Macdonald, Esq.  
**HOWREY SIMON ARNOLD & WHITE, L.L.P.**  
1299 Pennsylvania Avenue, N.W.  
Washington D.C. 20004

**IN THE MATTER OF CERTAIN SORTATION  
SYSTEMS, PARTS THEREOF, AND  
PRODUCTS CONTAINING SAME**

**INV. NO. 337-TA-460**

**PUBLIC MAILING LIST**

Donna Wirt  
LEXIS - NEXIS  
1150 18th Street, N.W.  
Suite 600  
Washington, D.C. 20036

Ronnita Green  
West Group  
Suite 230  
901 Fifteenth Street, N.W.  
Washington, D.C. 20005