



NEHRP Seismic Design Technical Brief No. 7



Seismic Design of Reinforced Concrete Mat Foundations

A Guide for Practicing Engineers

Ron Klemencic
Ian S. McFarlane
Neil M. Hawkins
Sissy Nikolaou

NEHRP Seismic Design

Technical Briefs

NEHRP (National Earthquake Hazards Reduction Program) Technical Briefs are published by NIST, the National Institute of Standards and Technology, as aids to the efficient transfer of NEHRP and other research into practice, thereby helping to reduce the nation's losses from earthquakes.

NIST National Institute of Standards and Technology

NIST is a federal technology agency within the U.S. Department of Commerce that promotes U.S. innovation and industrial competitiveness by advancing measurement science, standards, and technology in ways that enhance economic security and improve our quality of life. It is the lead agency of the NEHRP. Dr. John (Jack) R. Hayes, Jr., is the Director of NEHRP within NIST's Engineering Laboratory (EL). Dr. Steven L. McCabe managed the project to produce this Technical Brief for EL.

NEHRP Consultants Joint Venture

This NIST-funded publication is one of the products of the work of the NEHRP Consultants Joint Venture carried out under Contract SB134107CQ0019, Task Order 11175. The partners in the NEHRP Consultants Joint Venture are the Applied Technology Council (ATC) and the Consortium of Universities for Research in Earthquake Engineering (CUREE). The members of the Joint Venture Management Committee are James R. Harris, Robert Reitherman, Christopher Rojahn, and Andrew Whittaker, and the Program Manager is Jon A. Heintz.

About The Authors

Ron Klemencic, P.E., S.E., is President of Magnusson Klemencic Associates (MKA), a structural and civil engineering firm headquartered in Seattle, Washington. Ron is an American Concrete Institute (ACI) Fellow and serves on the ACI Board of Directors. He is a voting member of ACI 318, 318H, 318D, ITG 5, and 374. Ron is a former chairman of ACI 374 and was awarded the ACI 2010 Alfred E. Lindau Award. He recently led the development and U.S. adoption of Performance-Based Seismic Design methodology for high-rise structures.

Ian S. McFarlane, P.E., is a Senior Design Engineer at Magnusson Klemencic Associates (MKA), a structural and civil engineering firm headquartered in Seattle, Washington. He is the firm's in-house foundation design specialist, and has experience designing a number of building types including high-rise residential towers, healthcare, and office buildings.

Neil M. Hawkins, PhD, Dist. M. American Society of Civil Engineers, Hon. M. ACI, Fellow Structural Engineering Institute, Fellow Portland Cement Institute, is Professor Emeritus of Civil and Environmental Engineering, University of Illinois at Urbana-Champaign. He has served on the Main Committee and the Seismic Code Committee of ASCE 7 since 2001. He has been a member of the Main Committee and the Seismic Subcommittee of ACI 318 since 1995. He served on the Building Seismic

Safety Council (BSSC) Foundations and Concrete Subcommittees from 1987 through 2010 and on the BSSC Provisions Update Committee from 1997 through 2010.

Sissy Nikolaou, PhD, PE, is a Senior Associate at Mueser Rutledge Consulting Engineers in New York City. She leads the firm's geo-seismic services, which have been key on design or retrofit of several critical projects, such as the Hillview Reservoir Cover, Columbia University's Manhattanville Campus, and the Queensboro and Woodrow Wilson Bridges. She chairs the committee for the NYC Seismic Building Code. Sissy has received the Shamsheer Prakash award for Excellence in Geotechnical Earthquake Engineering and was recently elected as the first President of the New York-Northeast regional Earthquake Engineering Research Institute chapter.

About the Review Panel

The contributions of the three review panelists for this publication are gratefully acknowledged.

Gregg E. Brandow, PhD, P.E., S.E., is the former President of Brandow & Johnston, Structural Engineers, in Los Angeles, California, where he led the firm's design of over 4,000 projects, including schools, hospitals, and highrise buildings. He is now a Principal with Brandow & Nastar and a Professor of Engineering Practice at the University of Southern California. He has over 40 years of structural design experience, earthquake reconnaissance opportunities, and forensic engineering. He is active with SEI and ASCE and is Chair of the Structural Engineering Licensure Coalition.

Viral B. Patel, P.E., S.E., is Senior Principal and Managing Director of the Research and Development Group at Walter P. Moore and Associates Inc., a National structural/civil engineering firm headquartered in Houston, Texas. Mr. Patel is responsible for directing the Research & Development group, which develops and disseminates standardized resources, processes, and design tools to all Walter P Moore offices around the country. Mr. Patel also serves as consultant to senior project managers on all major projects throughout the firm. He is a member of ACI committees 375 and 314 and subcommittee 318-E.

James K. Wight, P.E., is the F.E. Richart, Jr. Collegiate Professor of Civil Engineering at the University of Michigan. He is a Fellow of ASCE and ACI. He is well-known nationally and internationally for his research in earthquake-resistant design of concrete structures. Professor Wight is the current President of the American Concrete Institute and has previously held several important positions including Chair of the ACI Building Code Committee. He has received numerous awards for his teaching and research including the ACI Joe Kelly Award, the C.P. Siess Award for Excellence in Structural Research, and the Wason Medal for the Most Meritorious Paper.



Applied Technology Council (ATC)
201 Redwood Shores Parkway - Suite 240
Redwood City, California 94065
(650) 595-1542
www.atcouncil.org email: atc@atcouncil.org



Consortium of Universities for Research in Earthquake Engineering (CUREE)
1301 South 46th Street - Building 420
Richmond, CA 94804
(510) 665-3529
www.curee.org email: curee@curee.org

NIST GCR 12-917-22

Seismic Design of Reinforced Concrete Mat Foundations

A Guide for Practicing Engineers

Prepared for
*U.S. Department of Commerce
Engineering Laboratory
National Institute of Standards and Technology
Gaithersburg, MD 20899-8600*

By

Ron Klemencic
Magnusson Klemencic Associates

Ian S. McFarlane
Magnusson Klemencic Associates

Neil M. Hawkins
University of Illinois, Urbana-Champaign

Sissy Nikolaou
Mueser Rutledge Consulting Engineers

August 2012



U.S. Department of Commerce
Rebecca M. Blank, Acting Secretary

National Institute of Standards and Technology
*Patrick D. Gallagher, Under Secretary of Commerce for
Standards and Technology and Director*

Contents

1. Introduction	1
2. Historical Perspectives.....	3
3. Soil Properties.....	6
4. Soil-Structure Interaction.....	8
5. Load Combinations.....	11
6. Proportioning.....	14
7. Analysis.....	16
8. Design.....	18
9. Mats Supported on Deep Foundation Elements.....	19
10. Detailing.....	20
11. Constructability Issues.....	22
12. References.....	24
13. Notation and Abbreviations.....	26
14. Credits.....	29

Disclaimers

This Technical Brief was prepared for the Engineering Laboratory of the National Institute of Standards and Technology (NIST) under the National Earthquake Hazards Reduction Program (NEHRP) Earthquake Structural and Engineering Research Contract SB134107CQ0019, Task Order 11175. The statements and conclusions contained herein are those of the authors and do not necessarily reflect the views and policies of NIST or the U.S. Government.

This report was produced by the NEHRP Consultants Joint Venture, a partnership of the Applied Technology Council (ATC) and the Consortium of Universities for Research in Earthquake Engineering (CUREE). While endeavoring to provide practical and accurate information, the NEHRP Consultants Joint Venture, the authors, and the reviewers assume no liability for, nor express or imply any warranty with regard to, the information contained herein. Users of the information contained in this report assume all liability arising from such use.

The policy of NIST is to use the International System of Units (metric units) in all of its publications. However, in North America in the construction and building materials industry, certain non-SI units are so widely used instead of SI units that it is more practical and less confusing to include measurement values for customary units only in this publication.

Cover photo – Mat foundation under construction.

How to Cite This Publication

Klemencic, Ron, McFarlane, Ian S., Hawkins, Neil M., and Nikolaou, Sissy (2012). "Seismic design of reinforced concrete mat foundations: A guide for practicing engineers," *NEHRP Seismic Design Technical Brief No. 7*, produced by the NEHRP Consultants Joint Venture, a partnership of the Applied Technology Council and the Consortium of Universities for Research in Earthquake Engineering, for the National Institute of Standards and Technology, Gaithersburg, MD, NIST GCR 12-917-22.

1. Introduction

Seismic design of reinforced concrete mat foundations has advanced significantly in the last twenty years. As analytical capabilities have improved, primarily in the form of finite element analysis, the mathematical modeling of these continuous structural elements has led to seemingly more precise designs. Yet, fundamental questions still remain regarding the seismic performance of these thick foundation systems.

This Technical Brief attempts to address what is known and what is unknown about this subject, so that a structural engineer can proceed with a seismic design in an informed manner. Because many of the parameters associated with a mat foundation design can be highly variable, designs that consider this variability are encouraged.

What is Known

Plate Mechanics. The mathematical modeling of continuous mat foundations has been correlated with laboratory testing, providing confidence that typical finite element modeling techniques can offer a reasonable representation of the performance of mat foundations.

Material Properties. Structural material properties of the concrete and reinforcing steel that comprise reinforced mat foundations are well defined and generally well documented.

What remains Unknown

Soil Properties. Despite thorough geotechnical investigations, additional challenges in seismic mat foundation design are still present, including properly identifying elastic dynamic soil properties, quantifying strain-dependent soil behavior under cyclic loading, and conducting sufficient in-situ and laboratory testing to accurately capture the variability of the subsurface conditions under the mat foundation.

Demand levels. Seismic demand levels defined by the current applicable building codes and standards in the United States are not the same as the actual forces a mat foundation may experience. Instead, demand levels are defined as inertial actions transferred by the super-structure considering Response Modification Factors, R . This approach can call into question the response of the foundation and the superstructure as a whole, which can be particularly important for buildings of significant height or complexity.

Seismic Ground Motions. When seismic demands provided in the codes and standards are not used and instead response history analyses are performed, the uncertainties of the regional hazard at the mat location should be considered. For large mat foundations, spatial variability of the ground motions in terms of wave passage and soil effects should be considered.

Building Codes and Standards

In this document, the following building codes and standards are frequently referred to as the following:

- 2012 edition of the International Building Code, IBC (2012), which provides the overall seismic and other design requirements; referred to as IBC
- 2010 edition of *Minimum Design Loads for Buildings and Other Structures*, ASCE/SEI 7-10, ASCE (2010), which defines the criteria for seismic and other loads; referred to as ASCE 7
- 2011 edition of *Building Code Requirements for Structural Concrete*, 318-11 American Concrete Institute, ACI (2011), which is the basic materials standard that applies to reinforced concrete mat foundations; referred to as ACI 318

Older editions of these codes and standards may currently be the legal basis for design in various jurisdictions in the United States, but toward the objective of making this Technical Brief a forward-looking guide and to keep it from quickly becoming outdated, the latest editions listed above are used here. Structural designers need to verify their locally applicable requirements and discuss design criteria with the building officials.

This Technical Brief, like companion ones in the NEHRP Seismic Design Technical Brief series, goes beyond minimum codes and standards criteria to suggest best practices and areas where special investigations are required.

Shear. Traditionally, mat foundations have been proportioned based on local punching shear demands associated with column loading. Global, one-way shear has not been well addressed and can be particularly important in large mats subjected to significant over-turning demands from concrete core walls, shear walls, or braced frames. There are also some unknowns regarding the transfer of overturning through flexure and punching shear from a wall to a mat foundation, as the ACI 318 provisions that are applied in practice were developed for slabs and columns.

Embedment of Reinforcing Steel. Current building code provisions require only that vertical reinforcing steel be developed for tension where moments and/or overturning forces exist. This embedment length can be much smaller than some very thick mat foundations, calling into question

the activation of the entire mat section in resisting the imposed forces.

Soil-Structure Interaction (SSI). Interaction of the structure with the supporting soil can be idealized through numerical modeling. These models can be tested for sensitivity to the underlying assumptions regarding soil and structural stiffness. Guidelines and standards for soil-structure interaction are still being developed as discussed in NIST (2012).

This Technical Brief is organized to lead the reader through the following sequence of topics:

- What is a Mat Foundation?
- Historical Perspectives
- Soil Properties
- Soil-Structure Interaction
- Load Combinations
- Proportioning
- Analysis
- Design
- Mats Supported on Deep Foundation Elements
- Detailing
- Constructability Issues

1.1 What is a Mat Foundation?

A reinforced concrete mat foundation is a common type of foundation system used in many buildings. They are a specific type of shallow foundation that uses bearing capacity of the soil at or near the building base to transmit the loads to the soil. Compared to individual spread footings, a mat foundation may encompass all or part of the building's footprint. Compared to an ordinary slab on grade, a reinforced concrete mat is much thicker and is subjected to more substantial loads from the building.

A mat foundation is often used where soil and load conditions could cause substantial differential settlement between individual spread footings but where conditions are not so poor as to require a deep foundation system. For buildings with significant overturning moments, which can occur in regions of high seismicity or because of irregularities of the superstructure, a mat foundation is commonly used to distribute the bearing pressure over a large footprint and/or to resist significant uplift forces that can develop. Another frequent application for a mat foundation is where individual spread footings would be large and close together. Similarly, where many grade beam ties between footings are required, it may not be economical to excavate and form individual spread footings as compared to building a single mat foundation. For

a basement that is below the water table, a mat foundation is often used to create a "bathtub" system to keep the basement dry and to use the weight of the mat to resist hydrostatic uplift forces. Where a mat is supported on deep foundation elements, the mat also functions as the pile cap.

The behavior of a mat foundation can be correlated to a two-way slab system turned upside down. The distributed soil pressure applied to the bottom of the mat is analogous to a distributed slab load, and the columns and walls above the mat become the supports for the mat foundation. Therefore, it is common to apply analysis and design methods from two-way slabs to a mat foundation.

The design forces, load combinations, and some analysis requirements for a mat foundation are in ASCE7, which has been adopted into the IBC. In adopting ASCE7 provisions, IBC includes some modifications and additions that will be discussed later. As noted in the sidebar on the previous page, IBC 2012 is the current version of this code but may not yet be adopted by all jurisdictions; therefore, the governing code should be confirmed for each particular project jurisdiction as appropriate. The design and detailing requirements for a reinforced concrete mat foundation are presented in ACI 318, which has been adopted by the IBC as an incorporated standard.

For concrete design, structural engineers predominately consider ultimate strength design methods where the ultimate/factored loading is compared to the member's nominal strength. This method has been incorporated into ACI 318 since the 1960s. However, geotechnical engineers predominately consider allowable stress design, comparing service loads to allowable stresses and soil bearing pressures. This fundamental difference must be understood and addressed when designing a mat foundation. There is on-going development in building code committees to codify ultimate strength design for geotechnical engineers, but its use is not yet commonplace. This issue of coordination between the structural engineer and geotechnical engineer will be addressed in greater detail throughout this Technical Brief.

Topics Beyond the Scope of this Document

Soil-structure interaction is only briefly addressed in this Technical Brief. For a complete discussion, refer to NIST GCR 12-917-21 "Soil-Structure Interaction of Building Structures" (NIST 2012).

The design of a mat foundation supporting tanks, vessels, and other non-building structures is not addressed in this Technical Brief.

Prestressed concrete is outside the scope of this document.

2. Historic Perspectives

2.1 General

The design of mat foundations has long been recognized as a problem in Soil-Structure Interaction that designers have strived to simplify by designing mats that can be classified as rigid bodies. More recent requirements for earthquake-resistant design have made that approach less appealing and have increased the need for detailed considerations of soil-structure interaction effects for mats. The increasing use of finite element analyses in the mid-1980s and subsequent increases in available computing power have made such detailed considerations more realistic and reliable. Hence, it is convenient to confine this historical perspective on mat foundation design to the body of knowledge developed prior to the mid-1980s and to have the remainder of this document address knowledge developed since then as a result of detailed finite element analyses. At approximately the same time as computational capabilities evolved significantly, structural engineers adopted ultimate strength design. Thus, the division of knowledge into that existing prior to the mid-1980s and that developed since is also consistent with the timeline of two ACI 336 committee reports (ACI Committee 336 1966, 1988) on foundation design. The procedures of the 1966 report were repeatedly reaffirmed until the publication of the second report in 1988. The 1988 report has continued to be reapproved by ACI pending completion of work on an updated document.

2.2 Early Designs

Mat foundations were originally envisaged as a floating foundation with distinct advantages where the soil was poor or unacceptable differential settlements were likely to occur. Early work showed that mats on sand (loose compacted, medium, or dense) posed few problems. The factor of safety assumed for such mats was twice that for an individual spread footing and therefore no strength difficulties were to be expected if the loading imposed on the mat by the superstructure was effectively uniform. The allowable soil pressure was governed by settlement and differential settlements between the walls and columns supported by a mat. Typically, these allowable soil bearing pressures were less than those for isolated footings subject to the same loading.

By contrast, mats on clays had factors of safety against bearing failures that were the same as those for footings and were dependent on the length-to-width ratio of the mat or footing. Otherwise the bearing strength was practically independent of the area loaded by the mat or footing. Many of the initial uses of mats were for large grain elevators and their performance demonstrated those findings.

A mat foundation was envisaged as a large combined footing and designed as an inverted slab system spanning between

columns and walls, carrying the building weight as a load assumed to be uniformly distributed over the soil. The principles of reinforced concrete design were used to design the mat with three types of mats recognized: flat plates, beams with a slab underneath (like waffle slab construction), and beams with a slab on top. For plates, design for moments and shears was based on the coefficients for flat slab design specified in the building code, with the slab thickness based on stiffness considerations and punching shears around columns and walls. By theory, a perfectly rigid structure located on an elastic subgrade has a minimum pressure near the center and maximum pressure at the edge. Designs were prepared assuming the ratio of the maximum to minimum pressure was about two, and the two design conditions of both uniform and varying soil pressures were used to proportion the mat. Consequently, resulting designs called for providing more reinforcement than that required by a more rigorous analysis. In addition, it was common to provide the same amount of reinforcement top and bottom in the mat. Where the primary design consideration was differential settlements resulting from uneven column or wall loads and a compressible layer or variations in the properties of the soil below the mat were present, beams were often used to stiffen the mat.

The typical rule of thumb used for a mat on sand was, for uniform loading, that the superstructure could tolerate a differential settlement of about 0.75 inches between adjacent columns, with a maximum settlement of 2 inches overall. For a mat on clay, the differential settlement was chiefly due to dishing and was roughly half the maximum settlement. Dishing refers to the deflected shape of the mat foundation. However, the mat thickness was typically not greater than about 0.01 times the radius of curvature, with some local increases acceptable around columns and walls.

2.3 Basic Foundation Design Procedures

The existing procedures of ACI 318 for the design of mats are based primarily on results of tests reported by Talbot (1913), Richart (1948), and ACI-ASCE Committee 326 (1962, 1974). The procedures effectively assume that foundations are designed using allowable stress for the soil and strength design for the concrete foundation. Three limiting conditions were assumed for the soil supporting the foundation: bearing failure of the soil under the foundation, serviceability failure because of excessive differential settlements causing nonstructural or structural damage to the superstructure, and excessive total settlements. Two limiting conditions must be considered for the concrete foundation below the columns and walls of the superstructure: local flexural failure of the foundation (including reinforcement anchorage failure) and shear failure of the foundation. The geotechnical engineer typically specified an allowable soil bearing pressure, q_a , a service load stress

that takes into consideration the three limiting conditions for the soil. The structural engineer then typically designed the foundation for an ultimate soil pressure, q_u , that resulted from the factored loads applied to the foundation. Soil pressures were traditionally calculated by assuming linear elastic action of the soil in compression and no tension capacity offered by the soil. For a centrally loaded foundation, as shown in **Figure 2-1**, the stress under the footing is given by:

$$q = P/A \pm My/I$$

where, as illustrated in **Figure 2-1(a)** and **Figure 2-1(b)**:

- P = axial force
- A = area of contact surface between the soil and the foundation
- I = moment of inertia of contact area A
- M = moment about centroidal axis of area A
- y = distance from centroidal axis to position where q is calculated

If separation (uplift) between the soil and the foundation is to be avoided, the eccentricity $e = M/P$ must lie within the kern of the contact surface. The kern area, which is shaded area in **Figure 2-1(c)**, is the area for which applied loads within that region will produce only compression over the area of the footing.

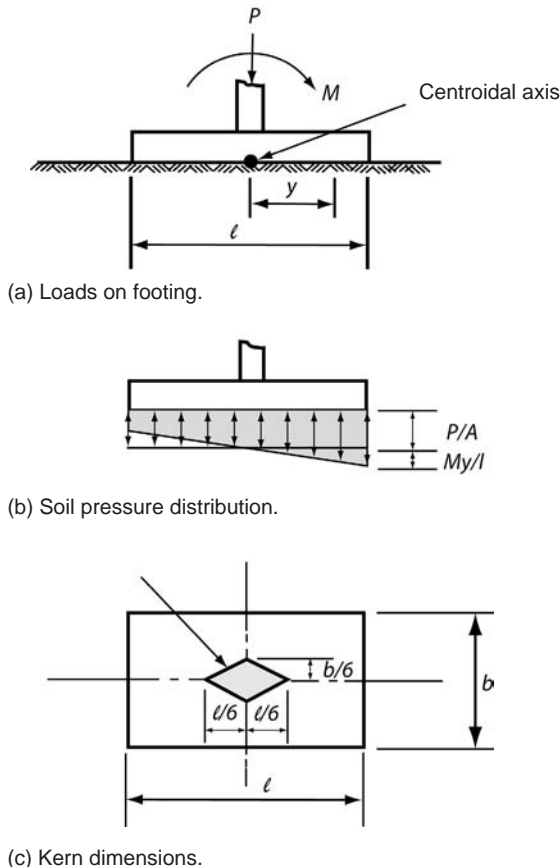

Figure 2-1 – Soil pressure under centrally loaded foundation.

Critical sections and design requirements for moments in footings are specified in §15.3 and §15.4 of ACI 318. Those requirements have remained essentially unchanged between the 1941 and the 2011 standards. In the 2011 standards, critical sections and design requirements for shear in footings are specified in §15.5. The shear strength is to be evaluated using the same provisions as those for elevated slabs. This design philosophy has remained essentially unchanged since 1941. However, nominal shear strengths and bond requirements have changed substantially over the same period. The current punching shear strength concepts date essentially from the 1963 edition of ACI-318 and development length concepts from the 1971 edition.

2.4 ACI 336.2R-66

This report (American Concrete Institute 1966) addresses the design of foundations carrying more than a single column or load. The report suggests that the contact pressures at the base of the foundation be taken as either a straight-line distribution, for a rigid foundation, or a distribution governed by elastic subgrade reaction, for a flexible foundation. The report provides recommendations to determine the foundation rigidity, considering the spacing of columns or walls, the relative rigidity of the foundation compared to the soil, and the rigidity of the superstructure. Given this determination, analysis guidelines are provided to design mats with strip-based analysis or with plate theory.

2.5 ACI 336.2R-88

This report (American Concrete Institute 1988) endorsed the procedures of the 1966 report and provided detailed comments on the constructive use of finite element methods to compute bending moments, displacements, and soil pressures. The report noted that although mats can be designed as rigid bodies or as flexible plates on an elastic foundation, a combination of analyses is desirable because the state of the art in computerized analysis was substantially ahead of the ability to accurately determine soil properties. There is great difficulty in predicting subgrade responses and in assigning even approximate properties to the soils because of soil-strata thickness, variations in soil properties both horizontally and vertically, and rate of loading. There are effects of mat shape and variation in superstructure loads and their development, and there are effects of superstructure stiffness on mat response and vice versa. For those reasons, mats were conservatively designed to ensure adequate performance.

The suggested design procedure using strength methods for proportioning the mat was as follows:

1. Proportion the mat plan using unfactored loads and overturning moments as:

$$q = \frac{\Sigma P}{b\ell} (1 \pm (6e_x/b) + (6e_y/\ell))$$

where the eccentricities e_x and e_y of the resultant column loads ΣP include the effects of any column moments and any overturning moments because of wind and other effects. The value of q is required to be less than the allowable limiting soil stress recommended by the geotechnical engineer. The value q is then scaled to a pseudo “ultimate” value as:

$$q_u = (\text{sum of factored design loads/sum of unfactored loads}) \cdot q$$

2. Compute the minimum required mat thickness based on punching shear at critical columns and walls without the use of shear reinforcement.

3. Design the reinforcing steel for bending based on the strip methods described in the ACI 336.2R-66 report.

4. Run a computer analysis of the resultant mat, such as with the finite element method as described in the ACI 336.2-88 report. Revise the rigid body design as necessary.

2.6 Observations

The methods described in the ACI 336.2R-66 report oversimplify behavior and result in designs that are too approximate for such critical and expensive structural components. In addition, these methods were not able to accurately predict settlement due to the rigid versus flexible behavior approximations.

The multiplication of the bearing pressure, q , by the pseudo factor in the ACI 336.2R-88 report is of limited accuracy as the value of q changes for each load combination. In addition, the use of the pseudo factor could be considered a superposition of results, which may not be appropriate for a nonlinear problem such as a mat foundation resting on soil.

The foregoing procedures are all effectively based on assuming mats of uniform thickness. It is often desirable to use mats with thicknesses varying based on the loads acting on the local area of the mat. Further, none of the prior committee reports have addressed the multiple issues related to the performance of mats subjected to earthquake loads. Both the 1966 and 1988 reports presented state-of-the-art techniques at the time of publication; however, many of the methods described are now obsolete due to the widespread use of three-dimensional finite element analysis software.

3. Soil Properties

3.1 *Communication Between the Structural Engineer and Geotechnical Engineer*

Critical to the appropriate design of any foundation system is the clear and effective communication between the structural and geotechnical engineers. Early discussions regarding the magnitude of acceptable building settlements and SSI effects are important prior to the definition of soil parameters and structural analysis and design techniques. Clarification of the governing code(s) and the consideration of seismic ground motions are required as a starting point.

Items that should be discussed include the following:

- Magnitude of acceptable differential and total settlements, with sustained gravity loading as well as transient wind and seismic demands being considered
- Soil type, site category, and structural occupancy “or risk” category
- Details of any soil-structure interaction analysis to be conducted
- Approach to the structural modeling
- Type of seismic analysis that will be performed (i.e., simple base shear, response spectrum, or dynamic response history analysis)
- Definition of the assumed “seismic base” of the building for defining the location and magnitude of input ground motions
- Elevation of mat, presence of any basement levels
- Drainage issues
- Presence of corrosive soils that may affect the concrete mix specification
- Existing adjacent structures, or substructure (such as tunnels), that could interact with the mat

3.2 *Parameters Needed From the Geotechnical Engineer*

To design a mat foundation, the geotechnical engineer will need to provide the following parameters to the structural engineer:

- Site Class
- Design response spectrum

- Allowable bearing pressure for static loads (indicating gross or net bearing pressures) and the assumed factor of safety
- Allowable bearing pressure for transient loads (wind or seismic) and the assumed factor of safety
- Subgrade modulus for both static and transient loadings (uniform or variable under the mat)
- Mat foundation spring and dashpots for static and dynamic conditions
- Anticipated total and differential settlements
- Passive soil resistance and friction coefficients for sliding calculations and the assumed factors of safety
- Guidance on how to adjust unit subgrade moduli for the size of the mat and on how to use an iterative process to account for consolidation settlement of clays from sustained loads
- Response histories, where applicable for input in the structural model
- Spatial variability of the seismic motions

This list includes only the parameters necessary to complete the mat foundation design. The first iteration of parameters should be made based on an analysis assuming a fixed base condition foundation, which would be the upper bound of the solution. In addition to this information, the geotechnical engineer will need to provide information to produce complete construction documents, such as subgrade preparation and drainage requirements.

3.3 *Definition of Soil Parameters*

3.3.1 *Allowable Soil Bearing Pressures*

Traditionally, the starting point in designing the mat foundation is setting an allowable soil bearing pressure. Currently, prescriptive codes provide recommendations for allowable soil bearing pressures for example, AASHTO (2010), based on the generic soil type. These values were developed for static load conditions and could be increased by at least a factor of 2 for the transient nature of the seismic loading within limits set by the local governing codes. Alternatively, an allowable bearing pressure for mats can be derived based on expected performance in terms of limiting settlements or other key performance indexes as those are defined by the project objectives under long-term and seismic loading.

3.3.2 *Subgrade Parameters*

Until recent years, the modeling of the subgrade has relied on the conventional parameter called the modulus of subgrade reaction, usually expressed in a force per volume parameter

for a 1-ft by 1-ft plate based on load tests. Modern modeling of the subgrade of a mat foundation should include both soil and mat foundation properties that represent load-displacement elastic springs distributed below the mat foundation.

For mat foundations considered to be rigid, subgrade parameters should be developed for six modes of vibration: three translational and three rotational. For each mode, soil can be replaced for the structural analysis by a dynamic spring of stiffness \bar{K}_z and by a dashpot of modulus C_z . Closed form solutions for the impedances of footings can be applied to derive the stiffness and damping for the mat foundations (Gazetas 1991). The stiffness and damping parameters represent an elastic spring concentrated at the foundation as shown in the physical model of **Figure 3-1** (Mylonakis et al. 2006). They can be distributed according to the stiffness and the loading of the mat and adjusted based on iterative procedures.

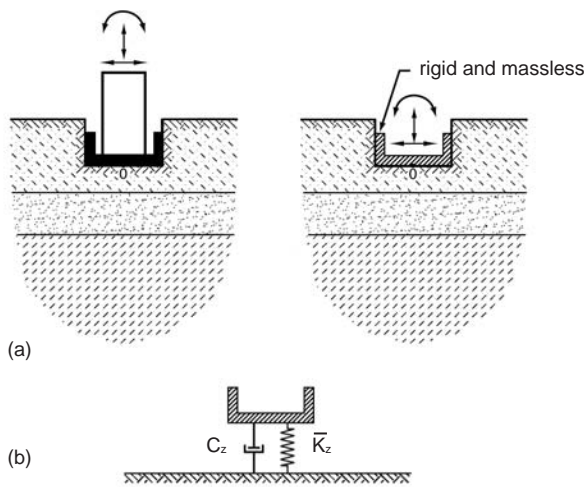

Figure 3-1 – Subgrade springs and dashpots: Physical interpretation shown for the vertical vibration mode of the mat foundation.

3.3.3 Soil Properties and Strain-Dependency

The most important soil parameter for the identification of the subgrade and modeling of the mat foundation is an elastic, low-strain parameter, such as the Young's Modulus or Shear Modulus, E_o or G_o , that can be directly derived from measurements of shear wave velocity, v_s , in the field using geophysical methods.

The in-situ measurements should generate minimal disturbance to the soil being tested so as to provide low-strain elastic values. These values should be adjusted and be compatible not only with the strains expected in the soil because of the earthquake shaking, but also for the long-term static loading conditions. The adjustments can be taken from the equivalent-linear properties as calculated from the site response analysis or can be evaluated from **Table 3-1**, derived from ASCE 7-10 Table 19-2-1, for the shear modulus parameter. The reduction in stiffness of the soil depends both on the soil type and on the level of ground excitation. These are represented by a generic soil type and a value of the seismic design acceleration

Site Class	$S_{DS} / 2.5$			
	≤ 0.1	0.2	0.4	≥ 0.8
A	1	1	1	1
B	1	0.98	0.95	0.90
C	0.95	0.90	0.75	0.60
D	0.90	0.75	0.50	0.10
E	0.60	0.40	0.05	<i>a</i>
F	<i>a</i>	<i>a</i>	<i>a</i>	<i>a</i>

a : should be evaluated from site specific analysis

Table 3-1 – Values of ratios, G/G_o , between strain-compatible shear modulus, G , with respect to the low strain values, G_o , for selected ground motion levels and soil types (ASCE 2010).

coefficient for short period accelerations, S_{DS} , divided by 2.5, equivalent to the peak ground acceleration at the site.

An upper- and lower-bound analysis using minimum and maximum ranges of the spring properties should be conducted to understand the sensitivity of the soil modulus to the overall behavior of the structural system. The guidelines of FEMA (2000) and of ASCE (2007) recommend bounds of 2.5 times of the expected values, depending on the variability in site conditions and scatter in measured soil properties. The analyses should always be compared to a fixed base assumption to better understand the importance of soil-structure interaction in the structural response and the shifts in structural behavior.

For the long-term condition of the mat foundation under static loading and larger strains in the soils than the transient ones expected in an earthquake, the in-situ elastic or shear modulus should further be reduced from those in **Table 3-1**. This is done empirically, with a rule of thumb using about 10 % of the low-strain elastic modulus. Alternatively, values from engineering practice manuals that correlate conventional soil site testing to static settlement parameters are used, for example in the EPRI Manual (Kulhawy and Mayne 1990). A sensitivity study should be conducted to evaluate the static values as well. The effective depth within which the springs are determined, z_p , is (NIST 2012):

$$\text{Horizontal (x \& y)} : z_p = B_e^A, B_e^A \sqrt{A/4} = \sqrt{BL}$$

$$\text{Rocking (xx \& y)} : z_p \approx B_e^A,$$

$$xx : B_e^I = \sqrt[4]{0.75I_x} = \sqrt[4]{B^3L},$$

$$yy : B_e^I = \sqrt[4]{0.75I_y} = \sqrt[4]{BL^3}$$

where B and L are the half-width and half-length of the mat, respectively. Especially for the case where no abrupt changes in the soil stiffness occur below rigid mat foundations, the effective depth for rocking can be reduced to up to half of the value computed above because the area of soil affected by the rocking motion of a mat is likely to be limited as compared to the relatively large dimensions of the mat foundation.

4. Soil-Structure Interaction

In the case of mat foundations placed within 10 feet of the ground surface, seismic ground shaking can be considered as the ground surface motion. In the case of mat foundations placed at greater depths (see **Figure 4-2**), the side walls and mat act as a single unit and interaction between ground and substructure may become more important in the seismic analysis and design of the building and its foundation.

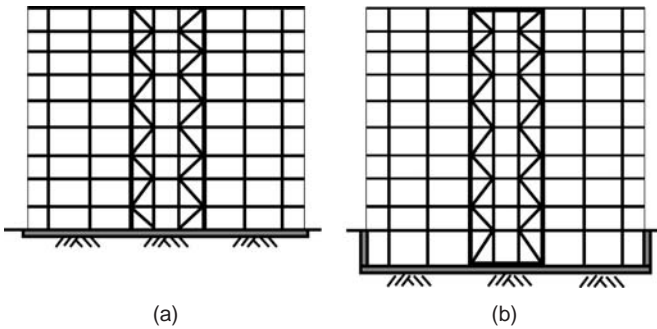

Figure 4-1 – Mat foundations placed (a) close to the ground surface and (b) at greater depths.

4.1 General Soil-Structure Interaction Principles

Where SSI may be important, there are three primary issues to consider (**Figure 4-3**):

- Kinematic Interaction - The modification of the effective input ground motion because of the depth and rigidity of the foundation system.
- Additional loading on basement sidewalls.
- The foundation impedances (springs and dashpots) that represent the surrounding and supporting soil in the Inertial Interaction studies that reflect reactions on the foundation elements because of the response of the superstructure to the seismic excitation.

A more detailed discussion of these topics can be found in NIST GCR 12-917-21, *Soil-Structure Interaction of Building Structures*, NIST (2012).

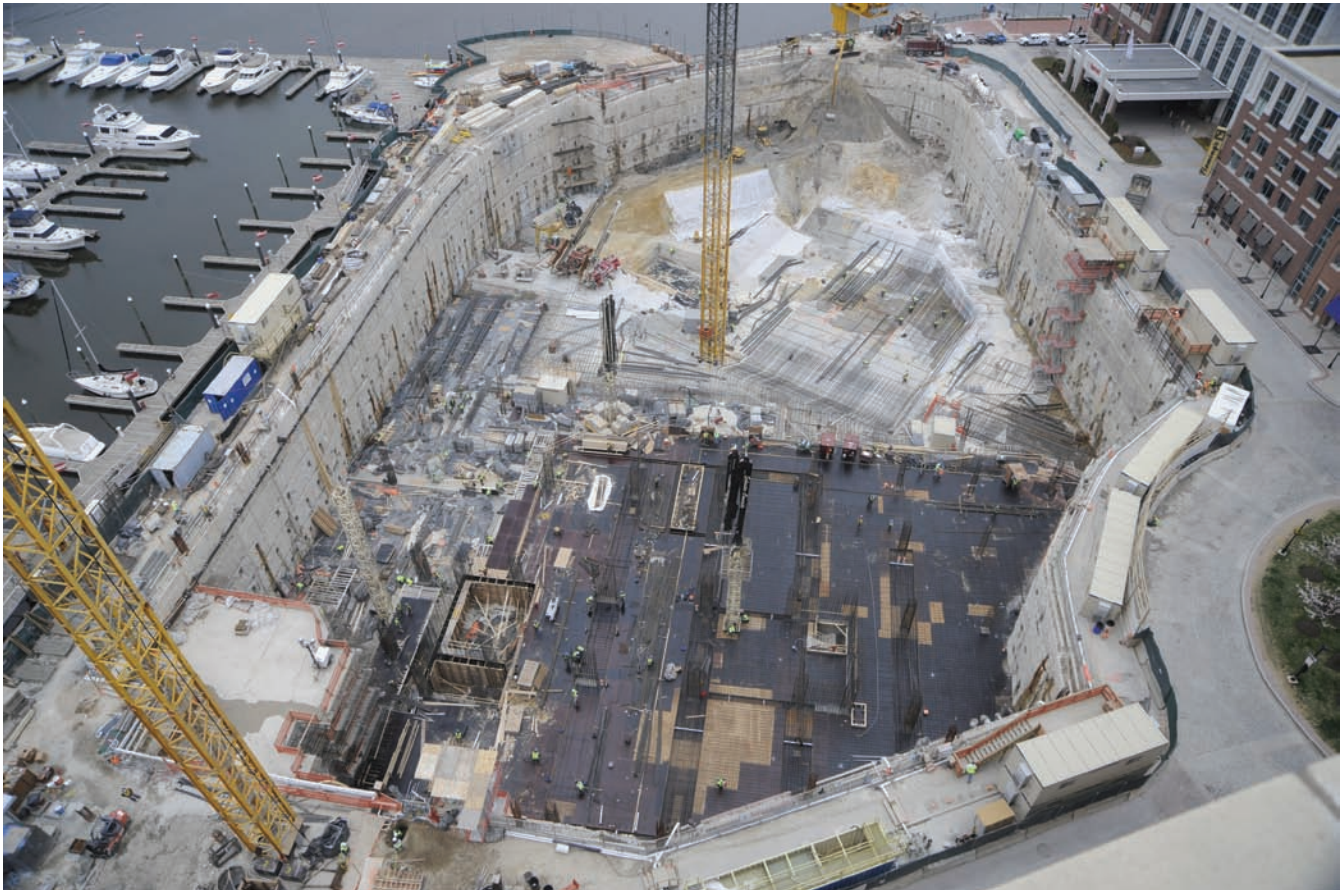

Figure 4-2 – Mat Foundation in Baltimore, MD.

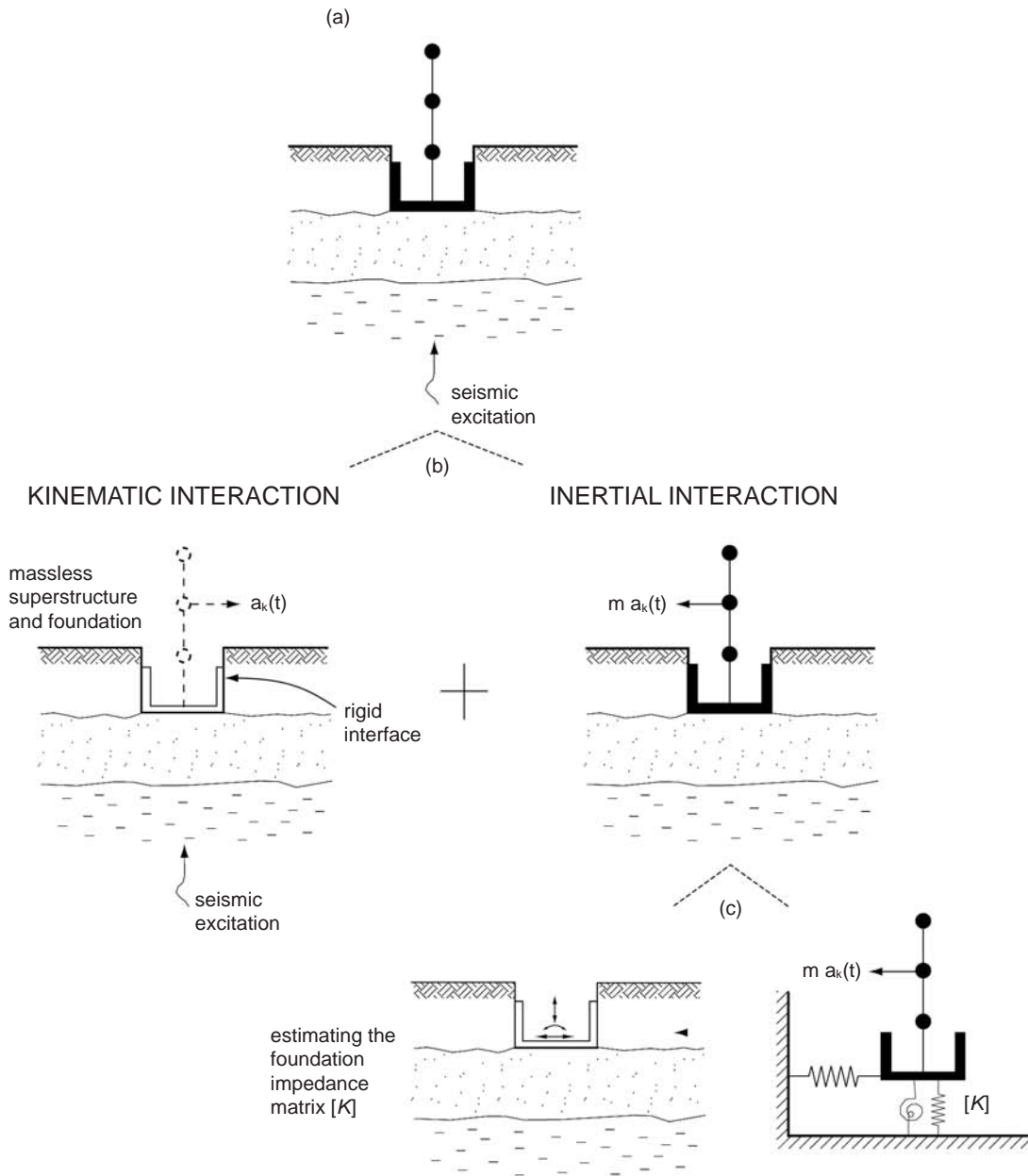

Figure 4-3 – (a) Geometry of soil-structure interaction, (b) decomposition of response into kinematic and inertial interaction, (c) two-step analysis of inertial interaction.

4.2 Practical Soil-Structure Interaction Implementation

In common code design applications, a design response spectrum $S_{a,design}$ is developed at the base of the mat. The superstructure will experience Foundation Input Motions (FIM) that will be filtered through the presence of the mat foundation in the horizontal and the rocking modes. For the structural period T ($T = 2\pi/\omega$), the transfer functions H_U and H_ϕ of **Figure 4-4** can be applied to calculate the FIM horizontal spectrum $S_{a,FIM}$ as $S_{a,FIM} = S_{a,design} \cdot H_U(T)$ and to simulate the rocking motion by applying equal-and-opposite vertical spectra ($1/2 H_\phi S_{a,design}$) at the two edges of the mat (**Figure 4-5**):

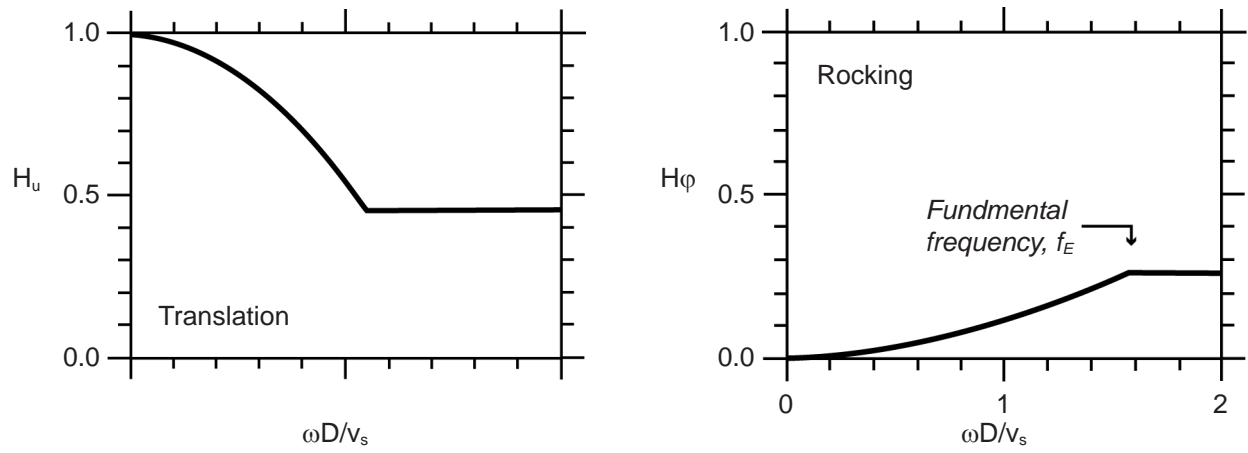

Figure 4-4 – Transfer functions for horizontal translation H_u and rocking H_ϕ (Stewart et al. 2003). For the horizontal motion, this is straightforward: $S_{a, FIM} = S_{a, design} \cdot H_u(T)$. For the rocking effects, the rotational motion can be applied as equal-and-opposite vertical accelerations ($1/2 H_\phi S_{a, design}$) at the two edges of the mat (Gazetas 2012).

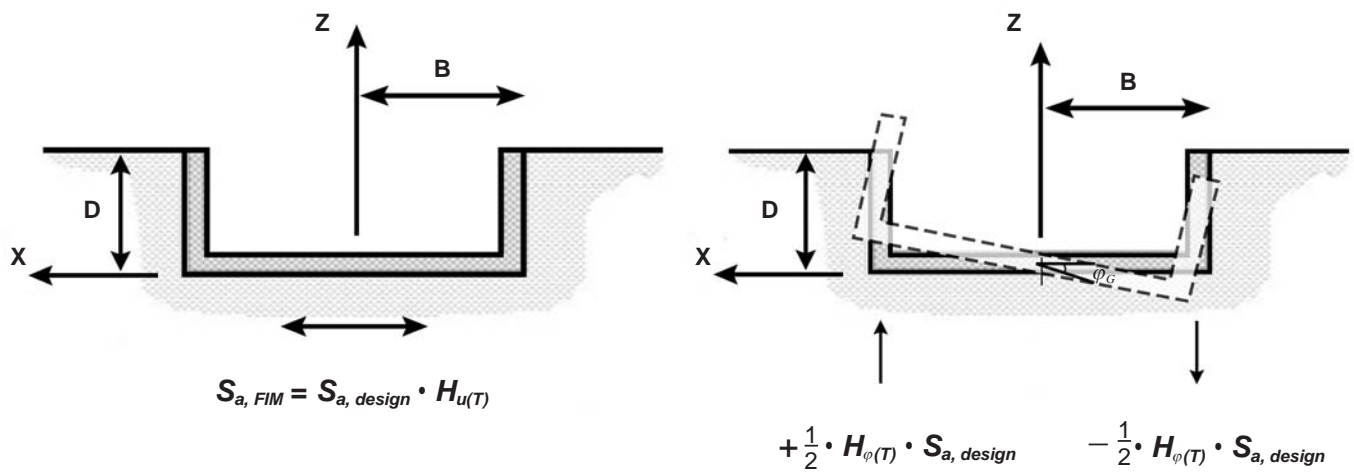

Figure 4-5 – Foundation Input Motion (FIM) accounting for combination of horizontal and rocking motion by applying a horizontal motion at the base and a pair of counterbalancing motions at the edges of the mat.

5. Load Combinations

Selecting the appropriate load combinations for the design of mat foundations is critical. More than one set of load combinations may be necessary to complete a mat foundation design. The divide between a geotechnical engineer working in allowable strength design (ASD) and structural engineer working in ultimate strength design (USD) adds another layer of complexity to load combinations. The typical procedure is to proportion the foundation using allowable strength design load combinations and then design the concrete foundation element using ultimate strength design load combinations. Proportioning in this case refers to sizing the soil-to-foundation interface in terms of bearing pressure. Design refers to the strength design of concrete, including the determination of required flexural or shear reinforcement.

5.1 ASD Load Combinations

There are two types of allowable strength design load combinations: basic allowable strength design and alternative basic allowable strength design. Basic allowable strength design load combinations (IBC 2012 §1605.3.1) are adopted from ASCE 7, with the high overturning load combination defined as $0.6D + 0.7E$. The alternative basic allowable strength design load combinations (IBC 2012 §1605.3.2) are legacy load combinations from the Uniform Building Code, with the high overturning load combination defined as $0.9D + E/1.4$.

A major difference between these load combinations for the design of a mat foundation is the reduction of seismic overturning effects at the soil-foundation interface as permitted by ASCE 7-10 §12.13.4. This reduction of seismic overturning (10 % or 25 % reduction depending on the analysis type) can be applied only if the basic allowable strength design load combinations is used, not when the alternative basic allowable strength design load combinations. The result is a mat foundation design using basic allowable strength design load combinations will typically be more conservative as compared to a design using the alternative basic allowable strength design load combinations. Although alternative basic allowable strength design combinations are allowed in IBC, it is expected they will eventually be removed from the code so that all load combinations will be adopted from ASCE 7.

Noticeably absent from current building codes are a safety factor for overturning and a required stability ratio. Historically, a requirement to maintain a stability ratio (sum of the resisting moments divided by sum of the overturning moments) equal or greater than 1.4 was adopted. However, current load combinations already include an inherent safety factor by reducing the factor on dead load. In addition, current building codes do not have an explicit requirement to eliminate foundation rocking. Therefore, provided that a mat foundation

is able to maintain equilibrium under the applicable allowable strength design load combination and not exceed the allowable bearing pressure of the soil, the mat would be considered stable and acceptable. If an adequate stability ratio is not achieved, then tiedowns will be required.

5.2 USD Load Combinations

Load and resistance factor design load combinations are provided in IBC 2012 §1605.2 and are adopted from ASCE 7. Similar to the basic allowable strength design load combinations, reducing the seismic overturning demands at the soil-foundation interface using the load and resistance factor design load combinations in accordance with ASCE 7-10 §12.13.4 is permitted.

5.3 Additional Load Combination Considerations

Earthquake load effects, E , are defined in ASCE 7-10 §12.4. Inherent in the definition of these seismic demand levels is the structural response modification factor, R , which is dependent on the type of lateral force-resisting system considered for the superstructure. The same overturning that is determined at the base of the superstructure is to be applied directly to the mat foundation. Consideration of higher foundation demand levels is triggered only by unusual structural geometries, such as a cantilever column system or a discontinuous lateral system, which require the consideration of a system overstrength factor, per ASCE 7-10 §12.4.3. By defining earthquake load effects with an inherent R value, some inelastic behavior is assumed in the superstructure and therefore implies that a mat foundation also may experience inelastic demands.

For any load combinations that include earthquake load effects, directionality in accordance with ASCE 7-10 §12.5 shall be considered. Additionally, the redundancy factor, ρ , per ASCE 7-10 §12.3.4 shall be included.

Another component of load combinations for mat foundation design is the vertical seismic load effect (E_v). Per ASCE 7-10 §12.4.2.2, E_v is permitted to be taken as zero when determining demands on the soil-structure interface of foundations. However, this is applied only to the basic allowable strength design load combinations provided in ASCE 7. Similarly, per IBC 2012 §1605.3.2, E_v is permitted to be taken as zero when using the alternative basic allowable strength design load combinations to proportion footings. Therefore, the vertical seismic load effect does not need to be included in either allowable strength design load combination for mat foundation design.

Seismic Demand Levels

In certain instances, it may be appropriate to consider maximum predicted seismic demands that may be imposed on a mat foundation. For instance, in the case of a high-rise building where the superstructure has been designed using Performance-Based Design techniques, the foundation designer should consider the demands that might be imposed by the superstructure so that the overall building system performs as expected. Numerous other instances of unique geometry and/or critical performance requirements may also encourage a more direct accounting of maximum predicted demand levels on the foundation. Some techniques that have been used when higher foundation demand levels are considered include the following:

- Evaluating the demands predicted by a nonlinear time history analysis
- Introducing code-defined overstrength factors in determining demand levels, attempting to ensure yielding in the lateral force-resisting system prior to inelastic behavior in the foundation
- Designing the foundation for lateral forces with a reduced R value when compared to the main lateral force-resisting system
- Detailing the foundation to avoid brittle failure, such as providing minimum flexural reinforcement to ensure

$$\phi M_n \geq 1.2 M_{cr} \geq 1.2 (f_r I_g / y_i)$$

ϕ Factor for Brittle Members in High-Seismic Design Categories

For structures with precast intermediate structural walls, special moment frames, or special structural walls resisting earthquake effects in Seismic Design Category D, E, or F, ACI 318 §9.3.4 requires that brittle structural members be designed for shear with $\phi = 0.6$. This phi factor is commonly applied to structural walls where it is impractical to provide enough shear reinforcement to raise the shear strength to exceed the nominal flexural strength. ACI 318 does not clearly state if this should be applied to shear in mat foundations. Many designers do not include this ϕ factor for mat foundation design; however, this requirement is the subject of further discussion in the process of updating ACI 318.

Ultimate Strength Design for Foundations: Proposed Code Revisions

Revisions have been proposed to ASCE 7 for the next code cycle to incorporate strength design of foundations as an alternative to the allowable stress design that is common practice. Although a strength design approach has not been included in current standards for new buildings, similar strength design principles have been used for the seismic evaluation and retrofit of existing buildings. The objective of the proposed provisions is to provide a more direct and realistic method to design foundations in accordance with ASCE 7 §12.1.5, which requires the design of foundations to resist the forces developed and movements imparted to the structure by the design ground motions. The proposed code revisions direct the designer to:

1. Establish foundation design forces that consider the degree of ductility desired in the superstructure design [based on whether the model assumes a fixed base or if foundation flexibility is considered.]
2. Establish nominal strengths for vertical, lateral, and rocking loading as best estimate average values.
3. Establish resistance factors for cohesive and cohesionless soils that reflect uncertainty in soil conditions and reliability of the geotechnical analysis methods.
4. Establish acceptance criteria that reflect the reliability of structural analysis methods.

The proposed provisions have not yet been formally adopted, but the proposal appears to address many questions identified throughout this report regarding ductility, foundation flexibility, and the discrepancies between allowable strength design and ultimate strength design for foundation design.

Backstay Effect

For structures with below-grade levels, a force couple can be developed between the grade level diaphragm and the mat foundation because of the stiffness of the surrounding basement walls. See **Figure 5-1**. The corresponding couple will effectively reduce the overturning moment delivered to the mat foundation by the lateral force-resisting system above. This reduction in demand level can be highly sensitive to analysis assumptions related to

the stiffness of the floor diaphragms, basement walls, and passive soil resistance. Because of these uncertainties, some designers elect to conservatively envelope the design by applying no less than the overturning moment at ground level directly to the mat foundation. Others elect to perform sensitivity analyses of the various stiffness assumptions in an attempt to better define the anticipated demand levels.

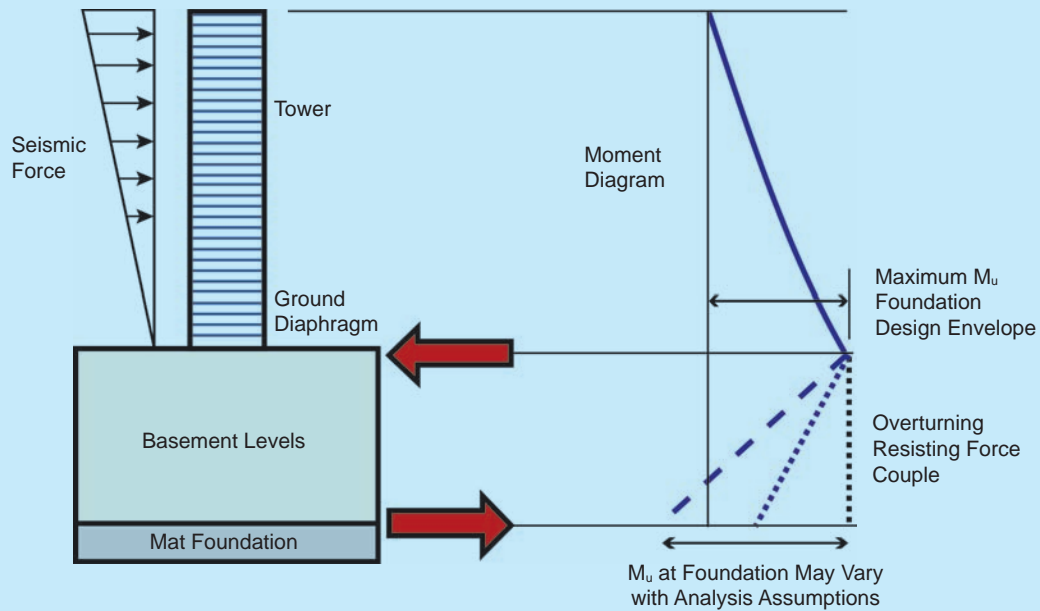

Figure 5-1 – Backstay effect on moment diagram.

6. Proportioning

During preliminary design, mat foundations are commonly proportioned considering overall building geometry, performance objectives, and allowable bearing stresses. The plan area of a mat foundation may be simply proportioned using a rigid-body approximation as described in the Historical Perspectives section of this Technical Brief. Traditionally, mat thickness has been determined considering punching shear demands in accordance with ACI 318 §11.11.2.1 at core walls, columns, and any substantial concentrated loaded areas. Mat foundations have not typically been proportioned considering one-way shear or flexure.

6.1 Proportioning for Bearing Pressure

For preliminary sizing, use of a rigid foundation assumption to estimate bearing pressures with a linear pressure distribution can be appropriate. Although this is not the most technically accurate approach when considering the actual foundation and subgrade stiffness, it can be a helpful tool for initial proportioning until a complete analysis can be performed. Refer to Section 2 for more discussion of this type of analysis.

6.2 Proportioning for Punching Shear

Punching shear design for a mat foundation is nearly identical to punching shear design for a slab per ACI 318 §11.11. The punching critical perimeter, b_o , is calculated at $d/2$ away from edges, corners, walls, or locations of concentrated loads. Then, V_c is calculated in accordance with ACI 318 §11.11.2.1. Shear stress on the punching interface is calculated as a combination of the shear caused by the axial load from the supported element plus the shear stress because of any unbalanced moment transferred via eccentricity of shear in accordance with ACI 318 §11.11.7.2.

Proportioning a mat foundation for two-way shear considering a maximum shear stress of $4\sqrt{f'_c}$ or less depending on aspect ratio of the critical shear perimeter per ACI 318 §11.11.2.1 without the use of shear reinforcement is recommended. If this shear stress limit is exceeded, shear reinforcing should be included. If shear reinforcement is used for two-way shear, the spacing and distribution requirements of ACI 318 §11.11.3.3 shall be met and the anchorage requirements of ACI 318 §12.3 shall be satisfied by engaging the flexural reinforcement with a hook.

See **Figure 6-1** for an example of punching shear at a column. For punching calculations of a shear wall on mat foundation, the design procedure is the same. See **Figure 6-2** for an example of critical perimeters to consider at shear walls.

Two-Way Shear

Punching shear tests of slabs have shown that Equation 11-33 of ACI 318, $V_c = 4\sqrt{f'_c}b_o d$ can be unconservative for thick members with low reinforcement ratios (Guandalini et al. 2009). In addition, ACI 318 §11.11.3.1 requires the use of V_c not greater than $2\sqrt{f'_c}b_o d$ when reinforcement is provided for punching shear resistance. Therefore, a value of $V_c = 2\sqrt{f'_c}b_o d$ is recommended for design purposes.

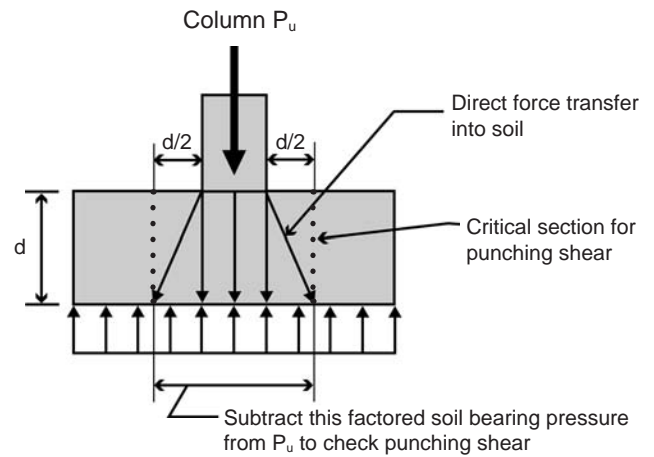

Figure 6-1 – Punching shear diagram at column.

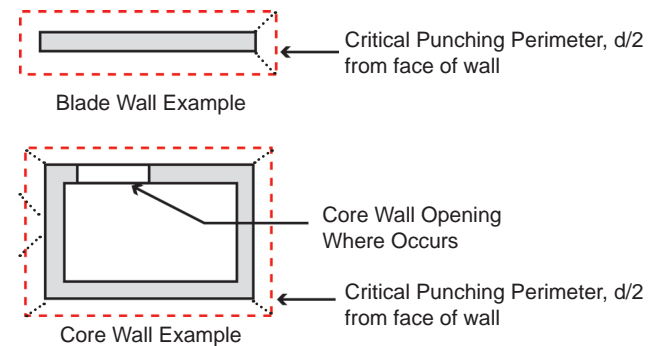

Figure 6-2 – Examples of critical punching perimeter at shear walls.

One-Way Shear

Overall building geometry may result in a mat foundation extending over the entire footprint of the superstructure. However, in many buildings, seismic resistance is assigned to a limited number of shear walls and/or braced frames, superstructure elements that impose concentrated overturning moments on the foundation. In these cases, it may be appropriate to consider one-way shear in proportioning the mat thickness to maintain acceptable shear stress levels. There is disagreement in the ACI code committees on the best way to address this specific issue. Two variables, the effective width and the maximum shear stress, are being debated. Current building code provisions allow for the consideration of the full width of the mat in evaluating one-way shear resistance. This does not seem reasonable or appropriate in the case of concentrated demands and the large width of mat foundations. Peak shear stresses have traditionally been considered as $2\sqrt{f'_c}$, while some research (Reineck et al., 2003) suggests that for thick structural elements in one-way shear this is unconservative, and $1\sqrt{f'_c}$ is a more appropriate shear stress threshold when no vertical reinforcement is provided. Larger crack widths in thick structural elements can result in reduced aggregate interlock and therefore reduced stress threshold. Recent practice has adopted the use of an effective width equal to the width of the superstructure element imposing the demand, plus one mat thickness either side of the

same element. This limited width, combined with a lower shear stress threshold of $1\sqrt{f'_c}$ for mats with no vertical reinforcement is generally considered a conservative approach, perhaps overly so.

More recent research has investigated the size effect on shear and found that one-way shear capacity for large footings can be predicted with a slenderness parameter of the shear span divided by member depth, where the shear span is the distance from the face of column or wall to the point of zero shear (Uzel et al., 2011). It is challenging to relate shear capacity to the shear span for a complex mat foundation where the shear span may be unclear and there may be more than 50 load combinations and, therefore, more than 50 shear diagrams to consider to evaluate one-way shear capacity.

When vertical reinforcement in accordance with ACI 318 §11.4.6 is provided in a mat foundation, aggregate interlock is maintained, and it is recommended to use $V_c = 2\sqrt{f'_c}bd$ in combination with V_s corresponding to the vertical reinforcement provided. Therefore, a thinner mat may be possible by providing a nominal amount of vertical reinforcement as compared to a mat without vertical reinforcement.

6.3 Proportioning for Sliding

Sliding of the mat must also be considered. Sliding may be resisted in whole or in part by friction between the mat foundation and subgrade. In addition, if the mat foundation is below grade with basement levels and a perimeter foundation wall, passive resistance of the surrounding soil may also be mobilized. The geotechnical engineer should advise the structural engineer on the use of friction and passive resistance, as it may not be appropriate to use these concurrently due to the differences in displacement required to mobilize each resistance mechanism. In addition, the construction means and methods such as excavation and backfill methods may affect the sliding resistance values. The geotechnical engineer will typically provide the structural engineer with the resistance values at a service level with a safety factor already included. Therefore, the service level sliding shear demands can be compared to the service level resistance values to ensure that the demand does not exceed capacity.

7. Analysis

Today, analysis of a mat foundation is typically performed using finite element analysis software. The geometry, loading, and soil spring properties are defined as inputs, and the analysis results typically include bearing pressure distributions, mat deformations, and moment and shear diagrams. Some analysis software can also be used to design and detail flexural reinforcement. This Technical Brief does not provide recommendations for any specific analysis software, but instead provides analysis guidance that is common to most mat foundation design.

The typical analysis for an isolated spread footing assumes that the foundation is rigid with respect to the soil, where a concentric load applied to the foundation would result in uniform soil bearing. When a spread footing is compared to a mat foundation, there is a fundamental difference in that the stiffness of the mat foundation is included in the analysis. The mat deforms as a result of bearing pressure, and bearing pressure is redistributed according to the mat deformation. Therefore, a non-uniform bearing pressure distribution can result. Methods used in the past often assumed a rigid mat foundation with respect to the soil, but analysis including foundation flexibility can result in significantly different bearing pressure distributions and therefore different moment and shear distributions.

7.1 Typical Modeling Practice

Finite element analysis of mat foundations typically assumes gross section concrete stiffness with no cracking. In developing a numerical model for a mat foundation analysis model, stiffness of the complete structure should be considered. For shear walls or basement walls above a mat foundation, the in-plane flexural stiffness should be added to the analysis model. This can be accomplished with a very deep beam or slab element. When beam or thickened slab elements are used, it should be verified that the model is not overestimating stiffness in an unanticipated manner, such as for torsion or weak axis bending.

At elevator pits, the pit configuration should be reflected in the analysis model. Where the pit depth is less than the mat thickness, a reduced mat thickness should be used. For pits that extend below the mat foundation, a combination of reduced mat thickness and flexural releases should be used to reflect the pit configuration. See **Figure 7-1** for examples.

Pit Within Mat:
Model with reduced mat
thickness at pit



Pit Below Mat:
Model with flexural release
at pit walls, reduced
thickness of pit slab



Figure 7-1 – Pit Configuration Effects on Analysis Model.

Stiffness Modifier Assumptions

Strict application of code procedures permits the use of gross cross section stiffness to determine moments and shears in a mat foundation. Depending on the relative stiffness of the mat foundation and soil, the use of effective moment of inertia could have a negligible or substantial effect on bearing pressure and moment distribution. Some examples have shown a change in peak bearing pressure of approximately 1 % to 5 %, and a change in peak moment of approximately 5 % to 50 %, as a result of using effective moment of inertia versus gross moment of inertia (Horvilleur and Patel 1995). Therefore, a sensitivity analysis is recommended to compare the results of gross moment of inertia versus effective moment of inertia assumptions.

Dishing (or cupping) can be visualized by considering the difference in pressure at the center of a uniformly loaded mat as compared to the very edge of the mat. The pressure at the edge of the mat dissipates quickly into the soil continuum because of lack of pressure on the adjacent soil, but the pressure at the center of the mat dissipates more slowly because of the adjacent loaded soil. To accurately model this effect, a variable subgrade modulus may need to be used in the analysis model. To select the appropriate modulus, iterations must be performed between the structural engineer and geotechnical engineer. Depending on the subgrade behavior, dishing may have a relatively small effect on soil pressure distribution but may have a more significant effect on bending moments in the mat foundation (Horvilleur and Patel 1995).

7.2 Analysis Options

Most analysis software commonly permit the use of a “thick plate” element formulation to include the effects of shear strains and therefore shear deformations. For very thick mat foundations, such as those with span-to-depth ratios of 10 or less, this option should be used to provide a more realistic force distribution.

No-tension iteration is a fundamental requirement of any finite element software for mat foundation analysis. Upon application of overturning or uplift forces on the mat, the software should iterate to determine a soil bearing pressure distribution that satisfies equilibrium but results in compression only in the soil springs with zero tension. For mat foundations with large overturning or significant uplift, the no-tension iteration may take significant computational effort. An analysis model that is unable to complete the no-tension iteration could result in a mat foundation that is under-proportioned, unstable, or both. It is necessary to perform the no-tension iteration analysis for each load combination. If the load cases were to be analyzed separately, it would not be accurate to superimpose the bearing pressure distribution, moments, shears, and deformations in the mat due to the nonlinearity of the analysis.

7.3 Iteration with Geotechnical Engineer

When a mat foundation analysis is completed, the resulting bearing pressure distributions and deformations should be discussed with and reviewed by the geotechnical engineer. **Figure 7-2** is an example of a bearing pressure distribution that may be sent to a geotechnical engineer, who should verify that the predicted bearing pressure falls within an acceptable range. At local peak bearing pressures, the geotechnical engineer may permit pressures exceeding initial recommendations provided that the majority of the bearing pressures are less than the allowable limit. Using the procedures from finite element method analysis, the geotechnical engineer may perform settlement analysis. Using the computed settlement from such analysis and the pressures from finite element method analysis by the structural engineer, the geotechnical engineer may revise the subgrade modulus and re-analyze the model. This iteration should be performed with the geotechnical engineer until an acceptable and compatible bearing pressure distribution and settlement are found.

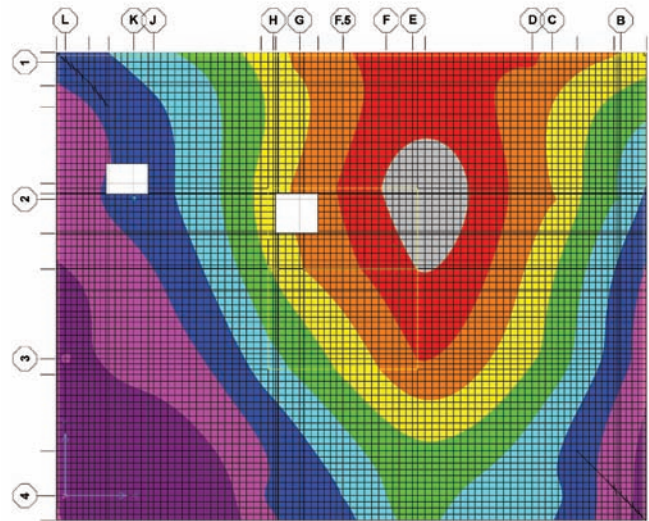

Figure 7-2 – Bearing pressure distribution example (peak value shown in grey color).

7.4 Sensitivity Analysis

Given the number of unknowns and approximations of material properties and stiffness in a mat foundation analysis, it is important to consider sensitivity of the model to the input parameters. Some parameters that may be studied in a sensitivity analysis include soil springs and dashpots, concrete modulus of elasticity, and gross versus effective moment of inertia. The sensitivity analysis should compare metrics such as bearing pressure, moment and shear diagrams, and settlements. These results can be used to help validate the analysis model and envelope the final design.

8. Design

To use the analysis results for design purposes, finite element analysis software will typically integrate the predicted moments and shears of all elements encompassed along a strip of defined width to produce design-strip moments and shears. For flexural design, the strip width should be wide enough to smooth local reinforcement spikes. It is common for detailing purposes to use the simplification that strips are equal in width to a column bay, as shown in **Figure 8-1**. Flexural design should be in accordance with ACI 318 Chapter 10. When determining reinforcement area, care should be taken to include proper cover (in accordance with ACI 318 §7.7) and appropriate d for mats with multiple layers of flexural reinforcement. Flexural demands should be checked at critical sections, such as the face of columns, the face of walls, and any mat thickness transitions.

Two-way or punching shear should be checked in accordance with ACI 318 §11.11 and as discussed in Section 6. Although two-way shear may have been checked in the proportioning process, it should be verified again for final design. If the mat thickness from the initial proportioning is found not to work for the final design check, additional two-way shear capacity

may be provided by increasing thickness locally, adding a plinth to increase the failure perimeter, or increasing concrete strength.

There is not a specific code requirement for strip width for one-way shear design. Some designers elect to check one-way shear using a strip width of the entire mat. Refer to the sidebar on page 15 for discussion of effective width for one-way shear design. One-way shear should be checked at d away from supports in accordance with ACI 318 §11.1.3.1. From the perspective of a mat foundation, columns or walls can be considered as supports. Therefore, there may be relatively few locations where one-way shear needs to be checked in a mat foundation depending on the thickness, geometry, and configuration of the superstructure. Refer to the sidebar on one-way shear on page 15 for a discussion of the shear strength of thick concrete sections. Where the concrete alone is inadequate to resist the one-way shear demand, shear reinforcement should be provided with vertical reinforcement legs in the mat foundation. See Section 10 for guidance on detailing vertical reinforcement in the mat.

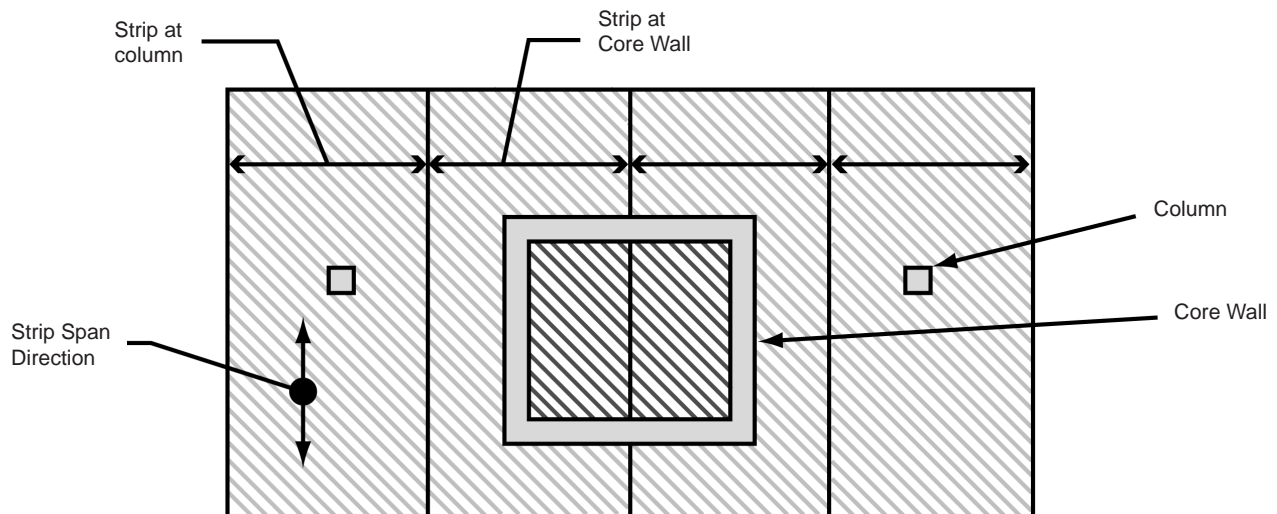

Figure 8-1 – Example strip width layout for flexure.

9. Mats Supported on Deep Foundation Elements

Mat foundations supported on deep foundation elements require additional consideration when compared to mat foundations supported directly on soil.

For mat foundations supported on closely spaced deep foundation elements, such as an extensive field of precast piles, the mat foundation may be analyzed and designed similarly to a mat supported directly on soil. The geotechnical engineer should be consulted to provide isolated springs for each foundation element. Most finite element analysis tools allow the definition of isolated springs with different tension and compression stiffness values, which may be appropriate depending on the deep foundation and soil properties. Upon definition of these springs, the remainder of the design is similar to a mat foundation supported directly on soil.

Alternatively, a mat foundation supported on few discrete and widely spaced deep foundation elements may require a much different approach to analysis and design. Where the angle between the foundation element axis and column or wall axis is 25° or greater, strut and tie analysis should be used in accordance with ACI 318 Appendix A. Alternatively, a finite element analysis that accounts for nonlinear distribution of strain could be used, however, strut and tie is more commonly used in practice. It may be necessary to build a three-dimensional strut and tie model to analyze a load path through a mat foundation supported on large deep foundation elements. A mat of this type is more analogous to a grade beam or pile cap. When a strut and tie analysis is not employed, ACI 318 §15.5.4 provides additional requirements for the critical shear section of footings supported by piles. If piles are used, then the critical location for the punching shear check may not be at a distance of $d/2$, as shown in **Figure 6-1**, but instead, at the location of the piles.

10. Detailing

The detailing of a mat foundation should consider the ACI 318 requirements for reinforcement development, anchorage, and curtailment. In addition, constructability issues should also be kept in mind, as discussed in Section 11 of this Technical Brief.

Flexural reinforcement should first be detailed to meet the minimum shrinkage and temperature reinforcement requirements of ACI 318 §7.12. Assuming Grade 60 deformed bar reinforcement, the ratio of reinforcement area to gross concrete area of 0.0018 is to be provided in each direction. This reinforcement requirement may be met by providing the required area in the top or bottom layer or in a combination of the two layers. Many designers will split this reinforcement equally between the top and bottom reinforcement mats. In addition to the minimum reinforcement mat, reinforcement should be added as necessary to meet flexural strength requirements. For a mat subject to uplift demands because of earthquake effects, additional top reinforcement should be provided to meet the requirements of ACI 318 §21.12.2.4. When bar spacing in a single layer becomes too congested, reinforcement should be placed in multiple layers. For this case, reinforcement layering and direction should be clearly identified in the design drawings. See **Figure 10-1**.

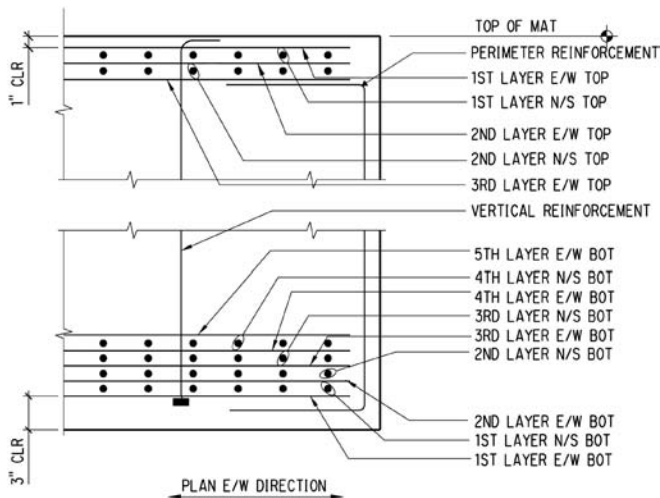

Figure 10-1 – Example of placement diagram to clarify layering.

Where reinforcement is added for flexural strength above the minimum reinforcement requirement, the added reinforcement may be curtailed in accordance with ACI 318 §12.10. Flexural reinforcement may be cut off at a distance of d or $12d_b$ beyond the point it is no longer required. In a thick mat foundation, this is almost always an extension distance d . It should also be verified that the bar is fully developed at the critical section, such as at the face of the column or wall. When cutoff points are determined, it is most efficient to round bar lengths to an interval that subdivides a stock length (20, 30, or 60 ft) to minimize waste.

Lap splices are needed where bars are longer than stock length, typically 60 ft. Lap splice lengths should be in accordance with ACI 318 §12.15. It is common to denote the typical lap splice length on the design drawings and then allow the detailer to lap where most efficient. Lap splices should be staggered 2 ft where possible.

In some markets, #14 and #18 bars are available in Grade 60 or Grade 75 and may be used to ease congestion of flexural reinforcement layers. The availability of these bars should be confirmed, and the use should be discussed with the contractor. Both #14 and #18 bars require mechanical or welded splices per ACI 318 §12.14.2.1, and #18 bars are quite heavy and may require heavy equipment for placement.

Where provided, shear reinforcement should be detailed in accordance with the anchorage requirements of ACI 318 §12.13, which requires that web reinforcement be extended as close to the tension and compression surfaces as possible. In addition, ACI 318 §12.13.2 requires hooking shear reinforcement around longitudinal reinforcement with additional embedment requirements for #6 and larger bars. These detailing requirements can be difficult to achieve for tightly spaced flexural reinforcement mats when using larger diameter shear reinforcement bar with a 90° hook. Shear reinforcement is often placed after both top and bottom mats are in place, and therefore requires fishing a hooked bar through the congested reinforcement mats, as shown in **Figure 10-2**. Some designers will use shear reinforcement with a head at the bottom that may be easily dropped through the top and bottom reinforcing mats. The disadvantage to headed bars is that they can be more costly than hooked bars.

At moment frame columns and shear wall boundary elements, dowels are required for the connection to the foundation. These dowels must lap with the column or wall reinforcement and be fully developed for tension into the mat. Refer to the sidebar for discussion of aspects of this issue that are not fully specified in the codes and standards.

Where a column or boundary element of a wall lands within one-half of the footing depth from the edge of a mat, ACI 318 §21.12.2.3 requires that edge reinforcement be provided into the depth of the footing. This requirement may be satisfied by providing U-bars developed for f_y in tension into the foundation. See **Figure 10-3**. ACI 318 does not specify how far to extend this reinforcement into the depth of the mat foundation; however, it is recommended to extend the reinforcement to the bottom of the mat foundation. This requirement should also be applied where an elevator pit is adjacent to a column or wall boundary element.



Figure 10-2 – Mat foundation under construction, 90° hook shear reinforcement (painted orange) being placed from above.

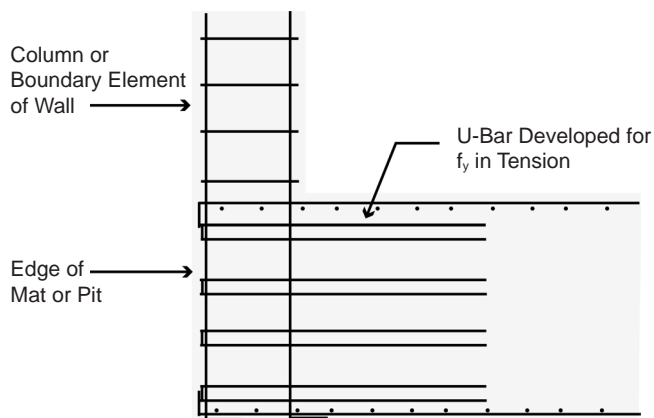

Figure 10-3 – Example of edge reinforcement at mat foundation edge.

There is no code requirement to provide vertical reinforcement around the edge of a mat foundation; however, it is good practice to detail this reinforcement because of the possible temperature gradient within the mat caused by the heat of hydration and because of the exposed edge condition. Where vertical shear reinforcement is being used throughout a mat, the edge reinforcement can match the vertical reinforcement size and spacing. Alternatively, a nominal bar of # 5 to # 9 spaced at 12 to 24 inches on center may be used, depending on the mat thickness.

Anchorage of Longitudinal Reinforcement

Longitudinal reinforcement of columns and structural walls must be developed into the mat foundation for tension in accordance with ACI 318-11 §21.12.2.1. There is no guidance in the building code regarding extension of longitudinal reinforcement any deeper than the development length for either straight or hooked reinforcement. In the case of very thick foundations, activation of the entire mat cross section can be called into question. Some designers argue that vertical reinforcement should be extended to the bottom of the mat foundation to create a complete load path to avoid the equivalent of a potential laminar tearing problem as seen in steel plates. Additionally, from a constructability standpoint, it may be easier to detail bars that hook at the bottom of the mat so that they are not “floating” between the top and bottom mats.

11. Constructability Issues

There are many considerations when detailing a mat foundation that can result in a more constructible and economical design.

First, consider the clear space between flexural reinforcement. In a single layer of reinforcement, ACI 318 §7.6.1 requires a minimum of one reinforcing bar diameter but not less than one inch between bars. In a mat foundation, the flexural reinforcement should be spaced out farther than this in an attempt to eliminate challenges with concrete consolidation or rock pockets. In addition, adequate space should be provided to drop a concrete vibrator into the full depth of the mat. This may mean allowing for specific clear zones of approximately six inches square in the top flexural reinforcement mat. This and other constructability requirements should be discussed with the contractor.

The top layer of flexural reinforcement requires tall chair supports or standees to place the reinforcing bars at the appropriate elevation, as shown in **Figure 11-1**. If vertical reinforcement is already present, the contractor may request to use the vertical reinforcement as chairs by laying the top reinforcing mat on top of the 90° hook of the vertical reinforcement. While the temporary stability and support of the reinforcement mat is typically the contractor's responsibility, the design engineer is frequently asked to evaluate the acceptability of this approach as it modifies the vertical reinforcement detailing. This detail alone does not satisfy development of shear reinforcement in accordance with ACI 318 §12.13; therefore, this detail should be avoided or supplemented with adequately detailed vertical reinforcement.

For foundations that are thick or cover a large footprint, (see **Figure 11-2**) it may not be feasible to place all of the concrete in a single, monolithic operation. In this case, it is necessary to use a vertical construction joint or bulkhead. Ideally, this joint should be located at a point where the flexural and shear demands are minimal. Flexural reinforcement should be lapped in accordance with ACI 318 §12.14 on each side of the vertical joint. Shear transfer through the joint should be checked in accordance with ACI 318 §11.6.4 for shear friction, with additional reinforcement provided as necessary.

A horizontal construction joint through the thickness of a mat foundation may also be considered. However, this requires consideration of shear flow through the joint and proper detailing of shear reinforcement through the horizontal joint. This type of construction joint is typically more difficult to analyze, design, and reinforce when compared to a vertical construction joint. Therefore, a vertical construction joint or bulkhead is the preferred joint method when a mat foundation cannot be cast monolithically.

The construction of most mat foundations is classified as massive concrete where the heat of hydration of the concrete should be considered. For massive concrete with a significant temperature differential between the core and exterior, cracks can develop as the concrete cures and cools. Therefore, it is common practice to limit the maximum temperature difference between the core and the surface of the foundation to 35 °F. This is known to be a conservative limit developed for the placement of unreinforced mass concrete (Gadja and Vangeem 2002). To relax the differential temperature requirement, performing a temperature analysis specific to the mat foundation in question is recommended because curing concrete at high temperatures can result in reduced compressive strength, so it is common practice to limit the maximum temperature during curing of the mass concrete to 170 °F.

Where excessive temperatures in massive concrete are a concern, the first consideration should be the concrete mix. The amount of cement in the mix should be minimized and replaced with slag or fly ash as much as possible to reduce and/or delay the peak heat of hydration. Some designers specify a compressive strength requirement for 56 or 90 days in lieu of 28 days to allow a mix with less cement content to cure for a longer duration to reach a similar strength of a 28-day mix with more cement content. Another method to control temperatures is to place the massive concrete at a cooler temperature by mixing with cooled water (or even ice). Many mat foundations are placed at night to take advantage of a reduced initial concrete temperature because of a lower ambient air temperature, which can reduce the absolute maximum temperature. More extreme mitigation methods that are sometimes used include cooling the aggregate with liquid nitrogen or embedding pipes to circulate cool water in the core of the concrete section.



Figure 11-1 – Vertical reinforcement and steel angle standees.



Figure 11-2 – A 10-ft thick mat foundation, pour in progress.

12. References

- AASHTO (2010). "LRFD bridge design specifications," 5th Edition, American Association of State Highway and Transportation Officials.
- ACI Committee 336 (1966). "Suggested design procedures for combined footings and mats," Report ACI 336.2R-66, American Concrete Institute, Farmington Hills, MI, 13 pp.
- ACI Committee 336 (1988). "Suggested analysis and design for combined footings and mats," Report ACI 336.2R-88, American Concrete Institute, Farmington Hills, MI, 20 pp.
- ACI (2011). *Building code requirements for structural concrete (ACI 318-11) and commentary*, American Concrete Institute, Farmington Hills, MI.
- ACI-ASCE Committee 326 (1962). "Shear and diagonal tension, part 3, slabs and footings," *ACI Journal*, Vol. 59 (3), March, pp. 353-396.
- ACI-ASCE Committee 326 (1974). "The shear strength of reinforced concrete members—slabs," *Proceedings, ASCE*, 100 (ST 8), pp. 1543-1591.
- ASCE (2007). *Seismic rehabilitation of existing buildings, Standard ASCE/SEI 41/06 (ASCE 41-06)*, American Society of Civil Engineers, Reston, VA.
- ASCE (2010). *Minimum design loads for buildings and other structures (ASCE/SEI 7-10)*, American Society of Civil Engineers, Reston, VA.
- FEMA (2000). *Report on the prestandard and commentary for the seismic rehabilitation of buildings*, FEMA 356, Federal Emergency Management Agency, Washington, DC.
- Gadja, J. and Vangeem, M. (2002). "Controlling temperatures in mass concrete," *Concrete International*, January 2002, pp. 59-62.
- Gazetas, G. (1991). "Formulas and charts for impedances of surface and embedded foundations," *J. Geotech. Eng. Div.*, American Society of Civil Engineers, 117(9), pp. 1363–81.
- Gazetas, G. (2012). Personal communication.
- Guandalini, S., Burdet, O. L., and Muttoni, A. (2009). "Punching tests of slabs with low reinforcement ratios," *ACI Structural Journal*, 106 (1), pp. 87-95.
- Horvilleur, J.F., and Patel, V. B. (1995). "Mat foundation design – A soil-structure interaction problem," *ACI Special Publication*, 152, pp. 51-94.
- IBC (2012). *International building code*, International Code Council, Washington, DC.
- Kausel, E., Roesset, J.M., Christian, J.T. (1976). "Nonlinear behavior in soil–structure interaction," *J. Geotech. Eng. Div.*, American Society of Civil Engineers, 102 (GT12), pp. 1159–78.
- Kulhawy, F.H. and Mayne, P.W. (1990). "Manual on estimating soil properties for foundation design," *Report EL-6800*, Electric Power Research Institute, Palo Alto, CA.
- Mylonakis, G., Nikolaou, S., and Gazetas, G. (2006). "Footings under seismic loading: Analysis and design issues with emphasis on bridge foundations," *Soil Dynamics & Earthquake Engineering*, 26(9), pp. 824-853.

NIST (2012). *Soil-Structure Interaction for Building Structures*, GCR 12-917-21, prepared by the NEHRP Consultants Joint Venture, a partnership of the Applied Technology Council and the Consortium for Universities for Research in Earthquake Engineering, for the National Institute of Standards and Technology, Gaithersburg, MD.

Reineck, K. H., Kuchma, D.A., Kim, K.S., and Marx, S. (2003). "Shear database for reinforced concrete members without shear reinforcement," *ACI Structural Journal*, 100, (2) pp. 240-249.

Richart, F.E., (1948). "Reinforced concrete wall and column footings," *ACI Journal*, 45 (10), pp. 97-128 and 45 (11), pp. 327-360.

Stewart, J.P., and Tileylioglu, S. (2007). "Input ground motions for tall buildings with subterranean levels." Pacific Earthquake Engineering Research Center (PEER) – Tall Buildings Initiative, Task 8. <http://peer.berkeley.edu/tbi/tasks/task-8/> Accessed 08-02-2012.

Talbot, A.N., (1913). *Reinforced concrete wall footings and column footings*, University of Illinois Experiment Station Bulletin 67, Urbana, IL, 96 pp.

Uzel, A., Podgorniak, B., Bentz, E.C., and Collins, M.P. (2003). "Design of large footings for one-way shear," *ACI Structural Journal*, 108 (2) pp. 131-138.

13. Notations and Abbreviations

a_k	kinematic acceleration
A	area
b	width of the footing
b_o	perimeter of critical section for shear
B	half-width of the mat
C_z	dashpot coefficient
d	distance from extreme compression fiber to centroid of longitudinal tension reinforcement
d_b	nominal diameter of bar
D	mat foundation embedment depth
e	eccentricity of axial load relative to geometric centroid of section
E	earthquake load effects
E_o	Young's Modulus, low-strain elastic value
E_v	vertical earthquake load effects
f'_c	specified compressive strength of concrete
f_E	fundamental frequency
f_r	Modulus of rupture of concrete
f_y	specified yield strength of reinforcement
G	shear modulus, strain-compatible
G_o	shear Modulus, low-strain elastic value
H_ϕ	rocking transfer function
H_U	horizontal transfer function
I	moment of inertia for the foundation
I_g	gross moment of inertia
K	static stiffness
\bar{K}_z	dynamic stiffness
ℓ	length of the footing
L	half-length of the mat
m	superstructure mass

M	moment
M_{cr}	cracking moment
M_n	nominal flexural strength
M_u	factored moment
P	axial force
P_u	factored axial force
q	bearing pressure
q_a	allowable soil bearing pressure
q_u	ultimate soil pressure
R	response modification factor
$S_{a,design}$	design response spectrum
$S_{a,FIM}$	Foundation Input Motion (FIM) response spectrum
S_{DS}	seismic design acceleration coefficient for short period accelerations
t	time
T	structural period
V_c	nominal shear strength provided by concrete
V_s	nominal shear strength provided by shear reinforcement
v_s	soil or rock shear wave velocity
x	longitudinal axis
y	distance from centroid
y	transverse axis
y_i	distance from centroidal axis of gross section
z	vertical axis
Z_p	effective depth within which the springs are determined
ρ	redundancy factor
ϕ	strength reduction factor
ω	cyclic frequency

Abbreviations

ACI	American Concrete Institute
ASCE	American Society of Civil Engineers
ATC	Applied Technology Council
BSSC	Building Seismic Safety Council
CUREE	Consortium of Universities for Research in Earthquake Engineering
IBC	International Building Code
NEHRP	National Earthquakes Hazard Reduction Program
NIST	National Institute of Standards and Technology
SEI	Structural Engineering Institute

14. Credits

Cover photo	Image courtesy of Magnusson Klemencic Associates
Figure 2-1	Image courtesy of Wight, James K.; MacGregor, James G., Reinforced Concrete: Mechanics and Design, 6th Edition, © 2013, p. 816. Reprinted by permission of Pearson Education, Inc., Upper Saddle River, NJ.
Figure 3.1.	Image courtesy of Mueser Rutledge Consulting Engineers
Figure 4-1	Image courtesy of Mueser Rutledge Consulting Engineers
Figure 4-2	Image courtesy of Armada Hoffler Construction Co., Inc.
Figure 4-3	Image courtesy of Mueser Rutledge Consulting Engineers after Mylonakis et al. 2006
Figure 4-4	Image courtesy of NIST GCR 12-917-21
Figure 4-5	Image courtesy of Mueser Rutledge Consulting Engineers
Figure 5-1	Image courtesy of Magnusson Klemencic Associates
Figure 6-1	Image courtesy of Magnusson Klemencic Associates
Figure 6-2	Image courtesy of Magnusson Klemencic Associates
Figure 7-1	Image courtesy of Magnusson Klemencic Associates
Figure 7-2	Image courtesy of Magnusson Klemencic Associates
Figure 8-1	Image courtesy of Magnusson Klemencic Associates
Figure 10-1	Image courtesy of Magnusson Klemencic Associates
Figure 10-2	Image courtesy of Magnusson Klemencic Associates
Figure 10-3	Image courtesy of Magnusson Klemencic Associates
Figure 11-1	Image courtesy of Magnusson Klemencic Associates
Figure 11-2	Image courtesy of Magnusson Klemencic Associates