

National Institute of Standards and Technology

NET ZERO ENERGY RESIDENTIAL TEST FACILITY

NIST Campus
Gaithersburg, MD



PROJECT DESCRIPTION

These plans describe an energy efficient net zero single family home to be built in Gaithersburg, MD. The home has four bedrooms, three full baths and a full basement. The drawing set and specifications were developed by Building Science Corporation with support from the Department of Energy's Building America Program. The home will be registered under USGBC's LEED for Homes program and will target Platinum Certification. During project planning and construction, all efforts should be made to meet the goals of this project.

BUILDING CODE

These plans are submitted under the 2009 Edition of the International Residential Code For One-and Two-Family Dwellings.

SQUARE FOOTAGES - Area calculations according to ANSI Z765-2003

Basement	1,518 sq. ft.
First Floor	1,518 sq. ft.
Second Floor	1,191 sq. ft.

PROJECT TEAM

CLIENT
National Institute of Standards and Technology
100 Bureau Drive
Gaithersburg, MD 20899
Contact: Hunter Fanney
(301) 975-5900
hunter.fanney@nist.gov

MEP ENGINEER
EBL Engineers, LLC
8005 Harford Road
Baltimore, MD 21234
Contact: Ed Hubner
(410) 668-8000
ehubner@eblengineers.com

SPECIFICATIONS CONSULTANT
Kalin Associates
1121 Washington Street
Newton, MA 02465
Contact: Mark Kalin
(617) 964-5477
mkalin@kalinassociates.com

ARCHITECT
Building Science Corporation
30 Forest Street
Somerville, MA 02143
Contact: Betsy Pettit
(978) 589-5100
betsy@building-science.com

LEED for HOMES PROVIDER
Everyday Green
1877 Ingleside Terrace NW
Washington, DC 20010
Contact: Andrea Foss
(202) 213-6984
andrea@everydaygreen.com

CONSTRUCTION MANAGER
Jacobs Engineering Group, Inc.
Contact:

DRAWING LIST

ARCHITECTURAL

A-001	DESIGN CRITERIA, ABBREVIATIONS, & GEN. STRUCTURAL NOTES
A-101	ARCHITECTURAL SITE PLAN
A-101A	ARCHITECTURAL SITE PLAN DETAILS
A-102	FOUNDATION PLAN
A-103	BASEMENT PLAN
A-104	FIRST FLOOR FRAMING PLAN
A-105	FIRST FLOOR PLAN
A-106	FIRST FLOOR KEY PLAN & WALL FRAMING ELEVATIONS
A-107	SCREEN PORCH & GARAGE KEY PLANS & WALL FRAMING ELEVATIONS
A-108	SECOND FLOOR & LOWER ATTIC FRAMING PLAN
A-109	SECOND FLOOR PLAN
A-110	SECOND FLOOR KEY PLAN & WALL FRAMING ELEVATIONS
A-111	ATTIC FRAMING PLAN
A-112	ROOF FRAMING PLAN
A-113	ROOF PLAN
A-114	LOWER ROOF OVERHANG FRAMING PLAN
A-115	UPPER ROOF OVERHANG FRAMING PLAN
A-121	FIRST AND SECOND FLOOR REFLECTED CEILING PLANS

A-201	EXTERIOR ELEVATIONS
A-202	EXTERIOR ELEVATIONS
A-203	EXTERIOR ELEVATIONS
A-204	INTERIOR ELEVATIONS
A-205	INTERIOR ELEVATIONS
A-206	INTERIOR ELEVATIONS
A-207	INTERIOR ELEVATIONS

A-301	BUILDING SECTION
A-302	BUILDING SECTION
A-303	BUILDING SECTION
A-304	BUILDING SECTION
A-305	GARAGE, BREEZEWAY & SCREEN PORCH SECTIONS

A-401	WALL SECTIONS & DETAILS
A-402	WALL SECTIONS

A-501A	REQUIRED CONSTRUCTION SEQUENCE - PART A
A-501B	REQUIRED CONSTRUCTION SEQUENCE - PART B
A-501C	REQUIRED CONSTRUCTION SEQUENCE - PART C
A-502	ADVANCED FRAMING DETAILS
A-503	WINDOW DETAILS & INSTALLATION SEQUENCE
A-504	DOOR DETAILS & INSTALLATION SEQUENCE
A-505	ENCLOSURE PENETRATION DETAILS & SEQUENCES
A-506	FOUNDATION DETAILS
A-507	HORIZONTAL DETAILS
A-508	VERTICAL DETAILS
A-509	ROOF DETAILS

A-601	WINDOW & DOOR SCHEDULES & TYPES
A-602	INTERIOR FINISH SCHEDULE
A-603	PENETRATION SCHEDULE

A-701	FIRST FLOOR OPEN WEB FLOOR TRUSS TYPE ELEVATIONS
A-702	SECOND FLOOR OPEN WEB FLOOR TRUSS TYPE ELEVATIONS

FIRE PROTECTION

F-001	FIRE PROTECTION GENERAL NOTES, LEGEND, AND ABBREVIATIONS
F-101	BASEMENT FLOOR PLAN
F-102	FIRST FLOOR PLAN
F-103	SECOND FLOOR PLAN
F-104	ATTIC FLOOR PLAN
F-601	FIRE PROTECTION DETAILS AND MATRIX

PLUMBING

P-101	BASEMENT FLOOR PLAN - PLUMBING
P-102	FIRST FLOOR PLAN - PLUMBING
P-103	SECOND FLOOR PLAN - PLUMBING
P-104	ATTIC FLOOR PLAN - PLUMBING
P-501	PLUMBING DETAILS
P-601	PLUMBING RISERS AND SCHEDULES

MECHANICAL

M-001	MECHANICAL LEGEND, SCHEDULES & DETAILS
M-002	MECHANICAL SITE PLAN
M-101	BASEMENT FLOOR PLAN - HVAC
M-102	FIRST FLOOR PLAN - HVAC
M-103	FIRST FLOOR PLAN GARAGE - HVAC
M-104	SECOND FLOOR PLAN - HVAC
M-105	ATTIC FLOOR PLAN - HVAC
M-106	BASEMENT FLOOR PLAN - RADIANT FLOOR HEAT
M-501	MECHANICAL DETAILS
M-502	MECHANICAL DETAILS
M-601	MECHANICAL SCHEDULES

ELECTRICAL

E-001	ELECTRICAL LEGEND, ABBREVIATIONS, SYMBOLS & LIGHTING FIXTURE SCHEDULE
E-101	BASEMENT FLOOR PLAN - ELECTRICAL
E-102	FIRST FLOOR PLAN - LIGHTING
E-103	FIRST FLOOR PLAN - POWER
E-104	SECOND FLOOR PLAN - LIGHTING & POWER
E-105	ATTIC FLOOR PLAN - ELECTRICAL
E-501	ELECTRICAL RISER DIAGRAM
E-502	ELECTRICAL DETAILS
E-601	ELECTRICAL PANEL SCHEDULES

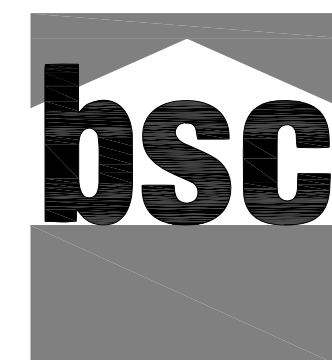

Building Science Corporation
30 Forest Street
Somerville, MA 02143
978.589.5100
Contact: Betsy Pettit
betsy@building-science.com

CONSTRUCTION DOCUMENTS
31 MARCH 2010 ISSUED FOR CONSTRUCTION



U.S. DEPARTMENT OF ENERGY | Energy Efficiency & Renewable Energy

GENERAL STRUCTURAL NOTES

1. ALL CONSTRUCTION SHALL BE IN ACCORDANCE WITH THESE PLANS, THE INTERNATIONAL RESIDENTIAL CODE (IRC 2009), TRUSS MANUFACTURER SHOP DRAWINGS, AND THE MATERIAL MANUFACTURERS' INSTALLATION INSTRUCTIONS.
2. WHERE CONFLICTING INFORMATION EXISTS BETWEEN THESE PLANS AND OTHER REFERENCED REQUIREMENTS, THE MORE STRINGENT REQUIREMENT SHALL APPLY UNLESS OTHERWISE APPROVED BY THE DESIGN PROFESSIONAL RESPONSIBLE FOR THESE PLANS.
3. THE CONTRACTOR IS RESPONSIBLE TO IDENTIFY AND RESOLVE ALL CONFLICTS AND DISCREPANCIES PRIOR TO AND DURING CONSTRUCTION AND FACILITATE PROPER CONSTRUCTION AS INTENDED BY THESE PLANS.
4. CONTRACTOR SHALL BE RESPONSIBLE FOR PROVIDING ADEQUATE STRUCTURAL SUPPORT OF CONSTRUCTION LOADS DURING ALL PHASES OF CONSTRUCTION INCLUDING, BUT NOT LIMITED TO, FOUNDATION BACKFILL, BRACING OF WALL FRAMING TO RESIST CONSTRUCTION FLOOR LOADS AND LATERAL BUILDING LOADING, BRACING OF TRUSSES DURING INSTALLATION AND SUBSEQUENT CONSTRUCTION LOADING, AND OTHER CONDITIONS AS DICTATED BY THE CONTRACTOR'S CONSTRUCTION PRACTICE.
5. CONTRACTOR SHALL COMPLY WITH THE MOST CURRENT CONSTRUCTION SAFETY REGULATIONS OF OSHA.
6. ALL CONSTRUCTION SHALL BE PERFORMED IN A GOOD, WORKMANLIKE MANNER FOLLOWING ACCEPTED CONSTRUCTION PRACTICES AND TOLERANCES. DEFECTIVE OR DAMAGED MATERIALS SHALL NOT BE USED AND SHALL BE REPLACED.

ENCLOSURE THERMAL ENVELOPE CRITERIA

COMPONENT	R-VALUE	U-VALUE
FRAMED WALLS	R-45	
ROOF	R-72	
WINDOWS		U-0.19
BASEMENT WALLS	R-23	
BASEMENT FLOOR	R-10	

DESIGN CRITERIA

STRUCTURAL DESIGN CRITERIA

DESIGN ITEM	CRITERIA	CODE REFERENCE
GROUND SNOW LOAD	30 PSF – SEE NOTE 1	IRC 2009 FIG R301.2(5), ASCE 7 FIG 7-1
BASIC WIND SPEED	90 MPH (GUST)	IRC 2003, FIG R301.2(4) ASCE 7, FIG 6-1C
WIND EXPOSURE	C	IRC 2003, SEC R301.2.1.4 ASCE 7, Sect 6.5.6
WIND BORNE DEBRIS REGION	NO	IRC 2009 Sect. R301.2.1.2 ASCE 7, Sect. 6.5.9
MAPPED SEISMIC HAZARD	S _s = 0.16g S ₁ = 0.05g	ASCE 7, CH 11 & CH 22
SEISMIC SITE CLASS	D (firm soil assumed) (F _a = 1.6; F _v = 2.4)	ASCE 7, Sect. 11.4.2
SEISMIC DESIGN SPECTRAL ACCELERATION PARAMETERS	SDS = 2/3(1.6)(0.16g) = 0.17g SD1 = 2/3(2.4)(0.05g) = 0.08g	ASCE 7, Sect. 11.4
SEISMIC DESIGN CATEGORY	B (IRC DWELLINGS EXEMPT)	ASCE 7, Sect. 11.6
IRC 2009, FIG R301.2(2) LIVE LOADS		IRC 2009, TABLE R301.4 ASCE TABLE 4-1
FLOORS & DECKS	40 PSF	
FLOORS (BEDROOM AREAS)	30 PSF	
ATTIC WITH STORAGE	20 PSF	
ATTIC W/O STORAGE	10 PSF	
ROOF	20 PSF - SEE NOTE 2	
DEAD LOADS	Main house roof/ceiling dead load is 20 psf to account for solar panels and non-standard framing.	
FLOOR	10 PSF	
ROOF	15 PSF (20 PSF main house)	
WALL	8 PSF	
FROST DEPTH	30 INCHES	Based on local practice
AIR-FREEZING INDEX	350 deg. F-DAYS	ASCE 32-01, IRC FIG. R403.3(2)
SOIL BEARING VALUE (ASD)	3,000 PSF – SEE NOTE 3	Based on preliminary information for soils report provided by NIST consultant (otherwise use presumptive value per IRC Table 401.4.1)
LATERAL SOIL LOAD	45 PCF	Backfill Soil Class I or II required per IRC 2009 Table R404.1.2(4) and Table 405.1
CONVENTIONAL LIGHT-FRAME CONSTRUCTION REQUIREMENTS	SEE CODE REFERENCE	IRC 2009, CH 3, 4, 5, 6, 8 IBC 2009, CH 18 AND SEC 2308

NOTES:

1. UNIFORM ROOF SNOW LOAD (23 PSF) SHALL BE USED ONLY WITH LOAD COMBINATIONS INVOLVING MORE LOAD EFFECTS THAN DEAD PLUS SNOW. GROUND SNOW LOAD SHALL BE USED FOR DESIGN OF ROOF FRAMING AND WHEN CHECKING D+S LOAD COMBINATION. DRIFT SNOW LOAD OF 54 PSF SHALL BE USED FOR LOWER ROOFS.
2. ROOF LIVE LOADS SHALL BE USED FOR THE DESIGN OF ROOF ELEMENTS ONLY. THESE LOADS ARE INTENDED TO ADDRESS MAINTENANCE, ACCESS, AND TEMPORARY CONSTRUCTION LOADS AND ARE NOT INTENDED FOR USE IN COMBINATION WITH OTHER LOAD EFFECTS.
3. MINIMUM 2,700 PSF SOIL BEARING VALUE REQUIRED FOR 36"X36" BASEMENT COLUMN FOOTINGS; MINIMUM 1,500 PSF SOIL BEARING VALUE REQUIRED FOR CONTINUOUS FOUNDATION WALLS.

ABBREVIATIONS

A.F.F.	ABOVE FINISHED FLOOR
B.O.	BOTTOM OF
BTW	BETWEEN
C/L	CENTER LINE
CLR.	CLEAR
EL.	ELEVATION
ELEV.	ELEVATION
EQ.	EQUAL
GWB	GYPSUM WALLBOARD
HRV	HEAT RECOVERY VENTILATOR
HVAC	HEATING VENTILATING AND AIR CONDITIONING
INSUL	INSULATION
LSL	LAMINATED STRAND LUMBER
MIN.	MINIMUM
O.C.	ON CENTER
PCF	POUNDS PER CUBIC FOOT
PV	PHOTOVOLTAIC
T & G	TONGUE & GROOVE
T.O.	TOP OF
TYP.	TYPICAL
W/	WITH
WD.	WOOD
W/O	WITHOUT

BUILDING SCIENCE CORPORATION



30 FOREST STREET SOMERVILLE, MA
T: (978) 589-5100 F: (978) 589-5103
www.buildingscience.com

CONSULTANT:

PROJECT:

National Institute of Standards and Technology

NET ZERO ENERGY RESIDENTIAL TEST FACILITY

NIST Campus
Gaithersburg, MD



U.S. DEPARTMENT OF ENERGY | Energy Efficiency & Renewable Energy

MARK	DATE	DESCRIPTION
ISSUE:	03/31/10	ISSUED FOR CONSTRUCTION

PROJECT NO:	NIST NZERTF
CAD DWG FILE:	A-PLOT-SPEC-NZERTF
DRAWN BY:	CG
CHECKED BY:	BP

COPYRIGHT © 2009
BUILDING SCIENCE CORPORATION

SHEET TITLE:

DESIGN CRITERIA, ABBREVIATIONS & GEN. STRUCTURAL NOTES

SCALE AS NOTED



A-001

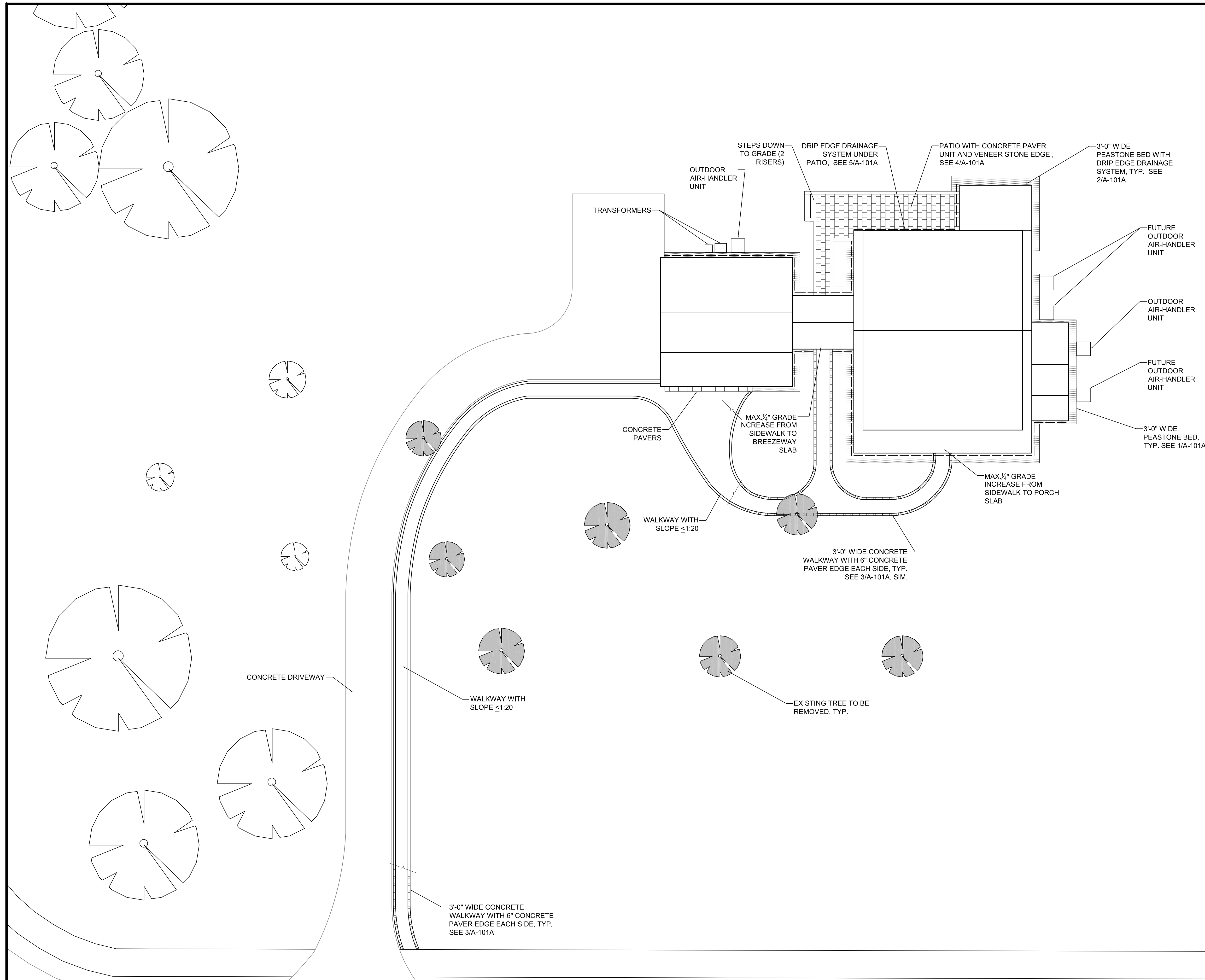

GENERAL SHEET NOTES

1. FOR PROPERTY LINE, LIMIT OF DISTURBANCE, GRADING CHANGES, LANDSCAPING, AND LOCATION OF BUILDING ON SITE, SEE SITE/CIVIL DRAWINGS.

BUILDING SCIENCE CORPORATION



30 FOREST STREET SOMERVILLE, MA
 T: (978) 589-5100 F: (978) 589-5103
 www.buildingscience.com

CONSULTANT:

PROJECT:

National Institute of Standards and Technology

NET ZERO ENERGY RESIDENTIAL TEST FACILITY

NIST Campus
 Gaithersburg, MD



MARK	DATE	DESCRIPTION
	05/07/10	UPDATED
ISSUE:	03/31/10	ISSUED FOR CONSTRUCTION

PROJECT NO: NIST NZERTF
 CAD DWG FILE: A-PLOT-PLAN-NZERTF
 DRAWN BY: HW
 CHECKED BY: BP

COPYRIGHT © 2009
 BUILDING SCIENCE CORPORATION

SHEET TITLE:

ARCHITECTURAL SITE PLAN

SCALE AS NOTED

A-101

1 ARCHITECTURAL SITE PLAN
 SCALE: 1:10

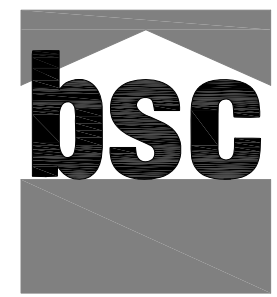

CONSULTANT:

PROJECT:

National Institute of Standards and Technology

NET ZERO ENERGY RESIDENTIAL TEST FACILITY

NIST Campus
 Gaithersburg, MD

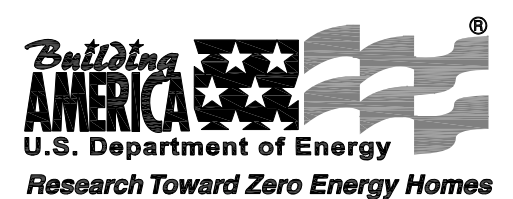

U.S. DEPARTMENT OF ENERGY | Energy Efficiency & Renewable Energy

MARK	DATE	DESCRIPTION
	05/07/10	UPDATED
ISSUE:	03/31/10	ISSUED FOR CONSTRUCTION

PROJECT NO: NIST NZERTF
 CAD DWG FILE: A-PLOT-PLAN-NZERTF
 DRAWN BY: HW
 CHECKED BY: BP

COPYRIGHT © 2009
 BUILDING SCIENCE CORPORATION

SHEET TITLE:

ARCHITECTURAL SITE PLAN DETAILS

SCALE AS NOTED

A-101A

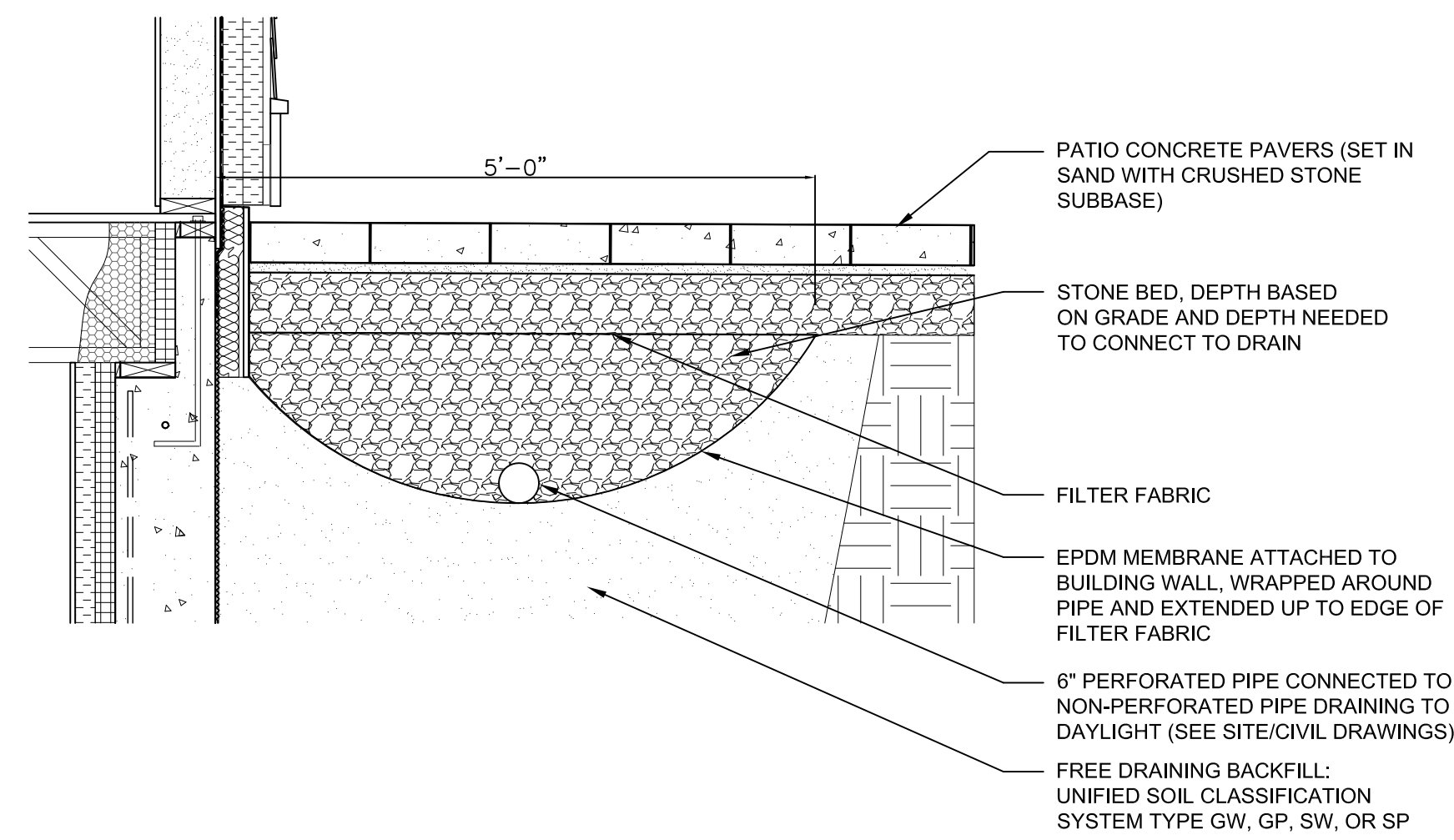

5 DRIP EDGE DRAINAGE UNDER PATIO
 SCALE: 3/4" = 1'-0"

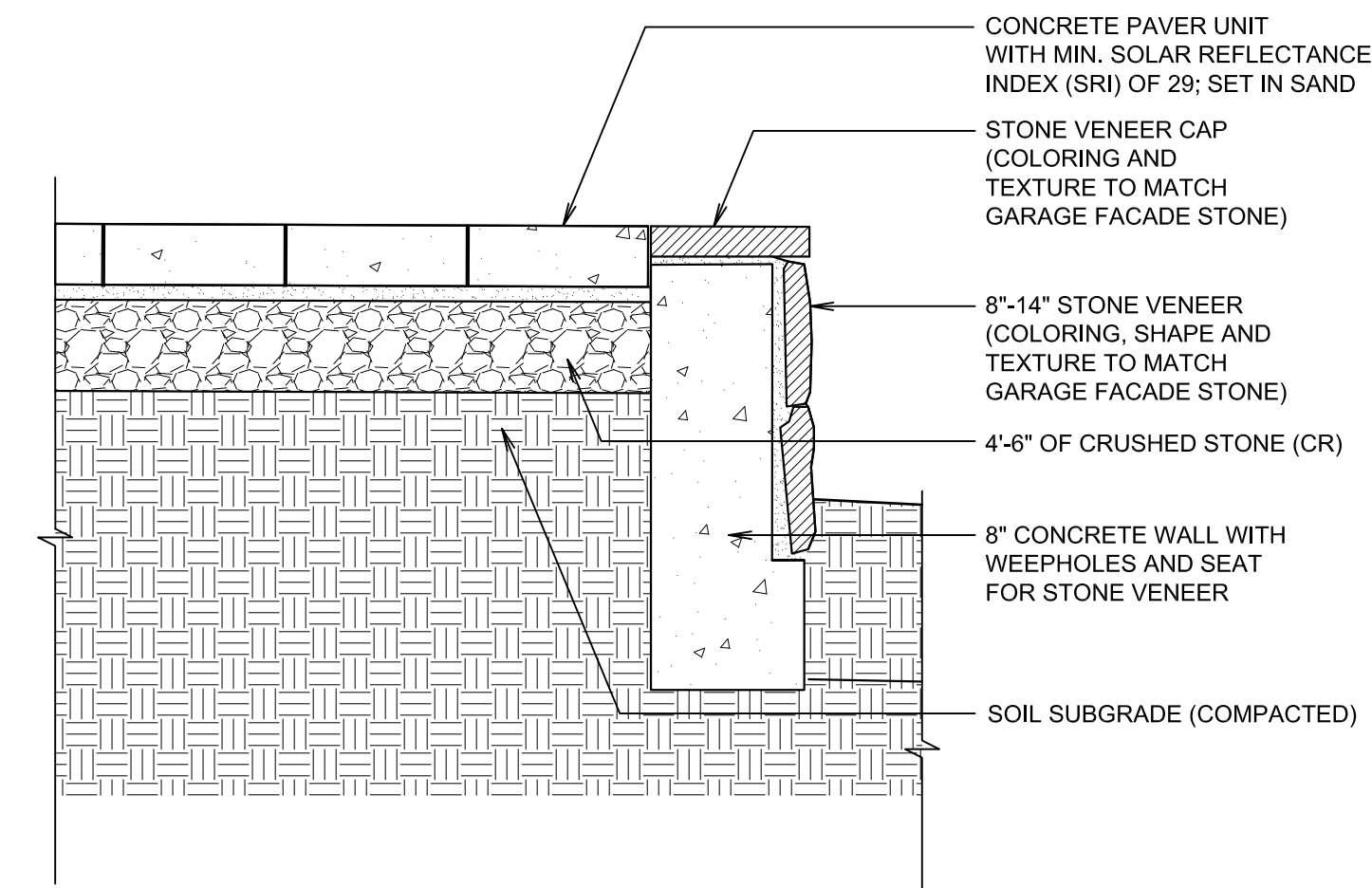

4 PATIO EDGE
 SCALE: 1" = 1'-0"

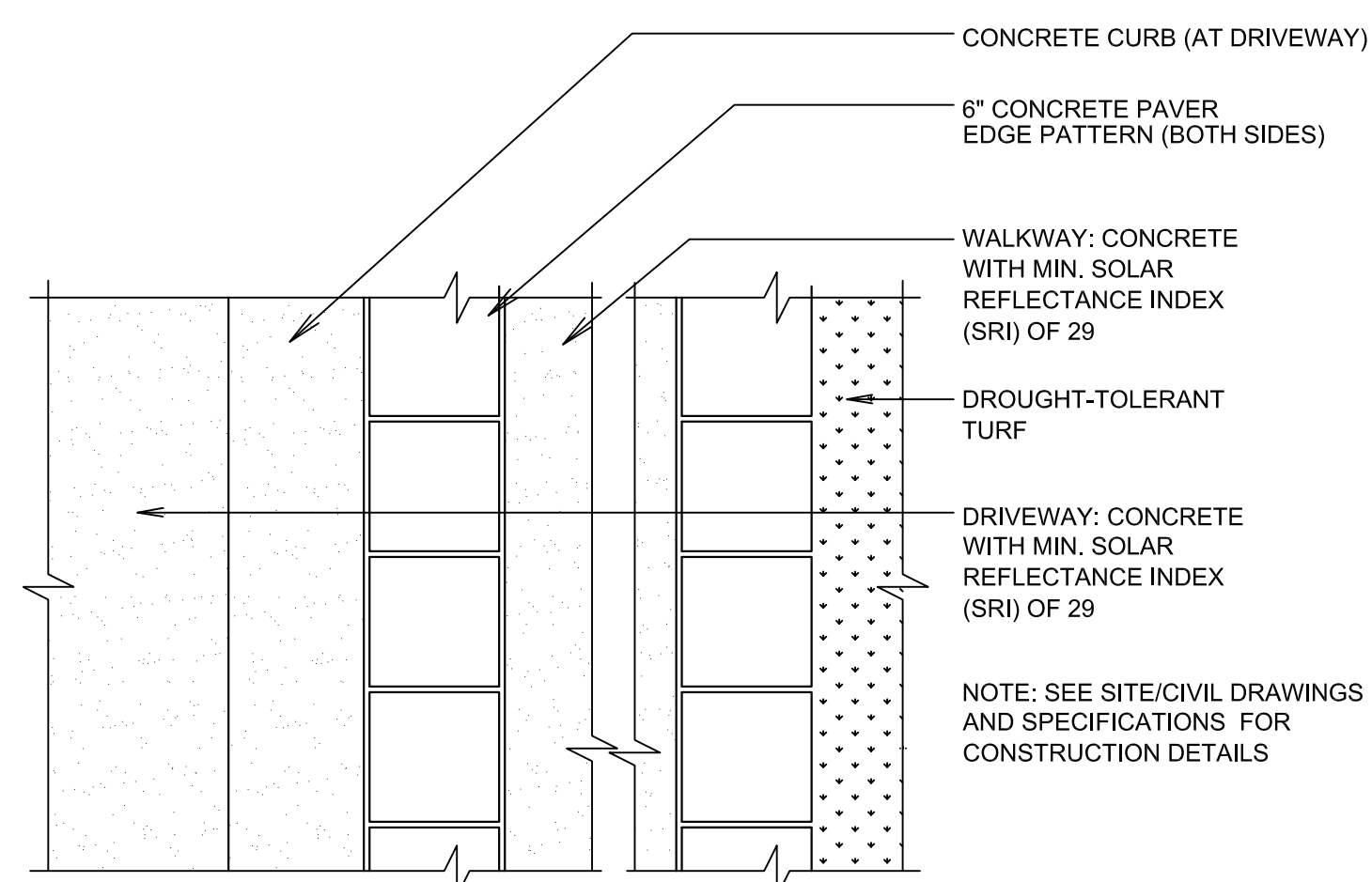

3 PAVING PLAN
 SCALE: 1" = 1'-0"

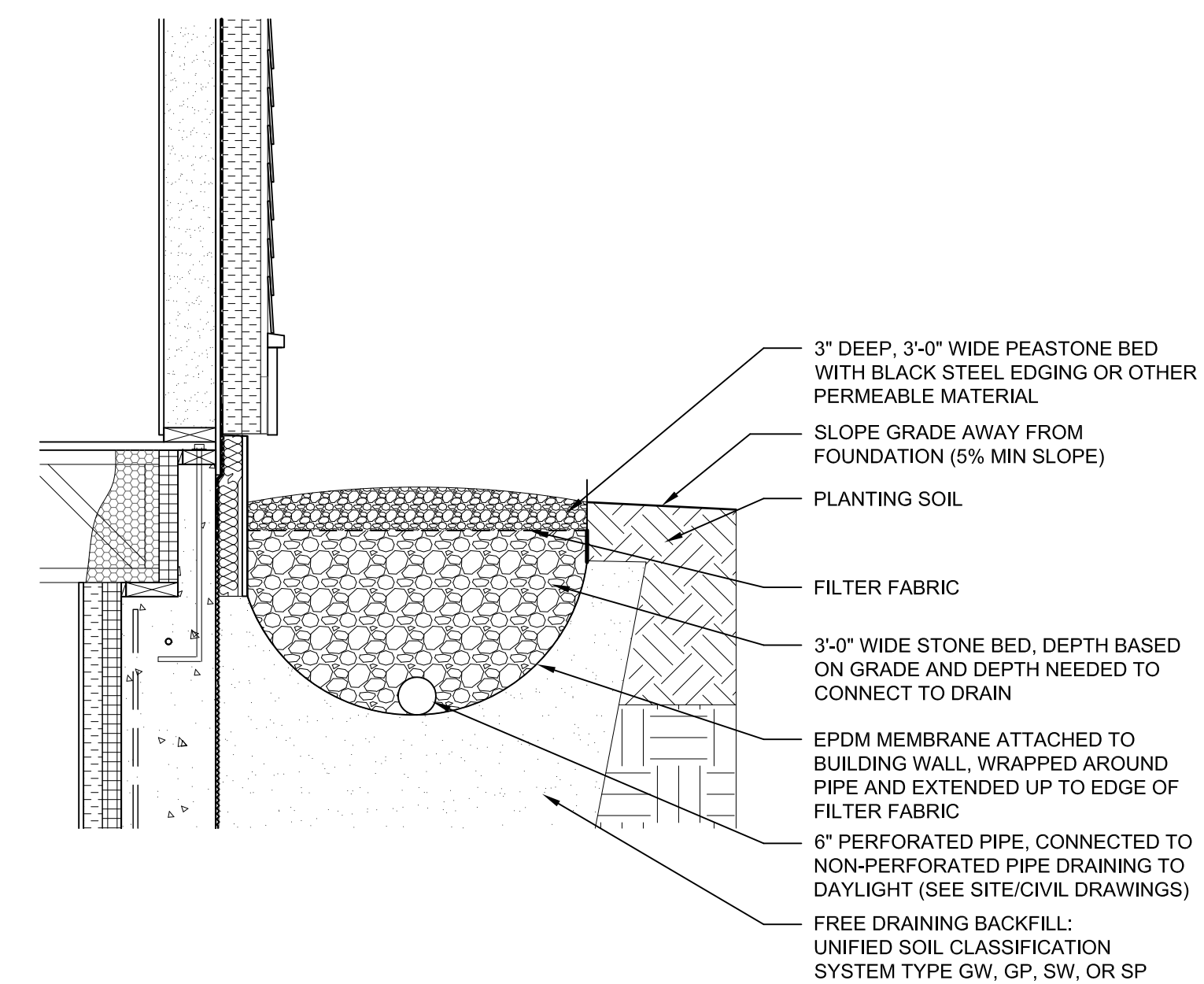

2 PEASTONE BED WITH DRIP EDGE DRAINAGE
 SCALE: 3/4" = 1'-0"

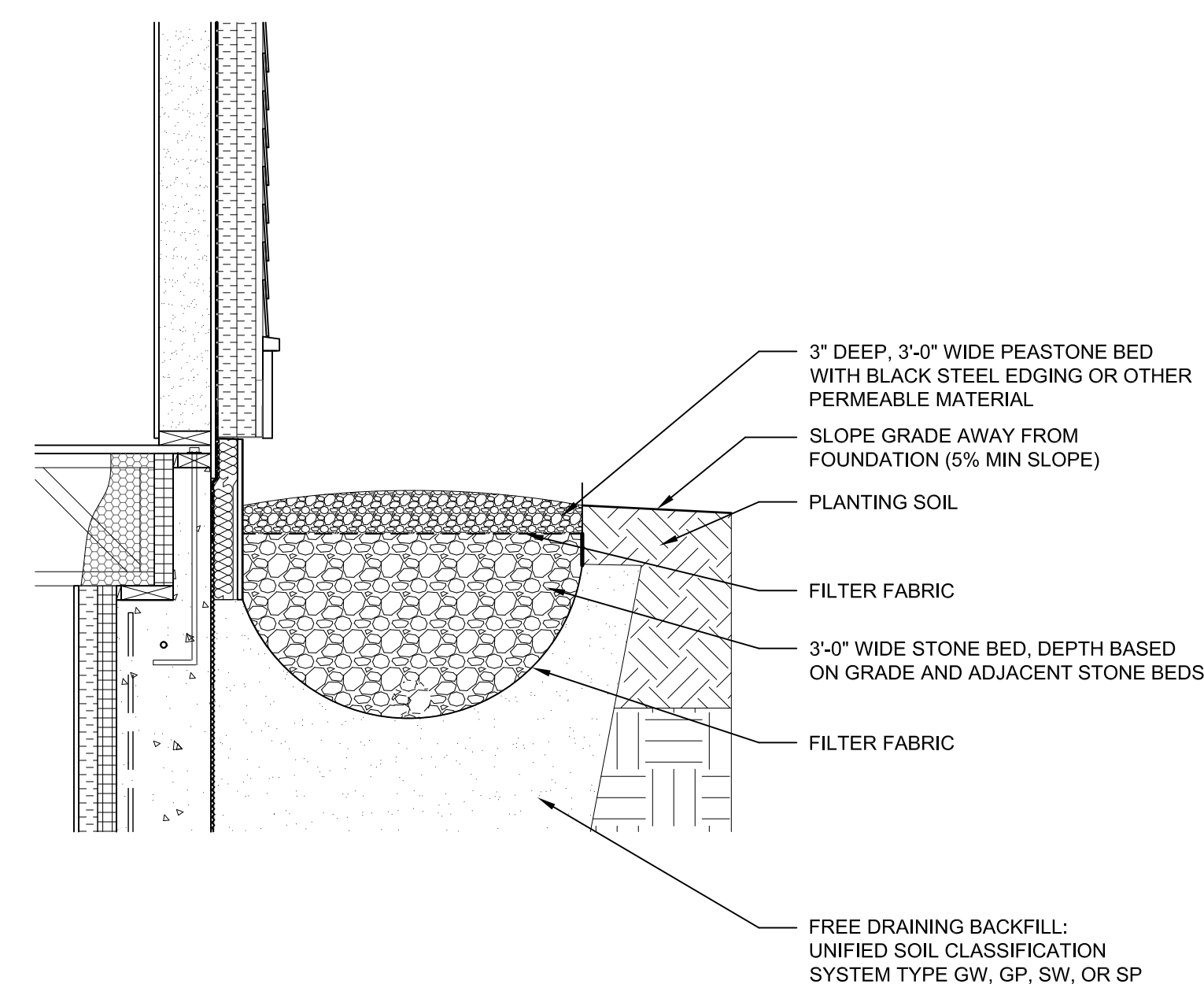

1 PEASTONE BED W/O DRIP EDGE DRAINAGE
 SCALE: 3/4" = 1'-0"

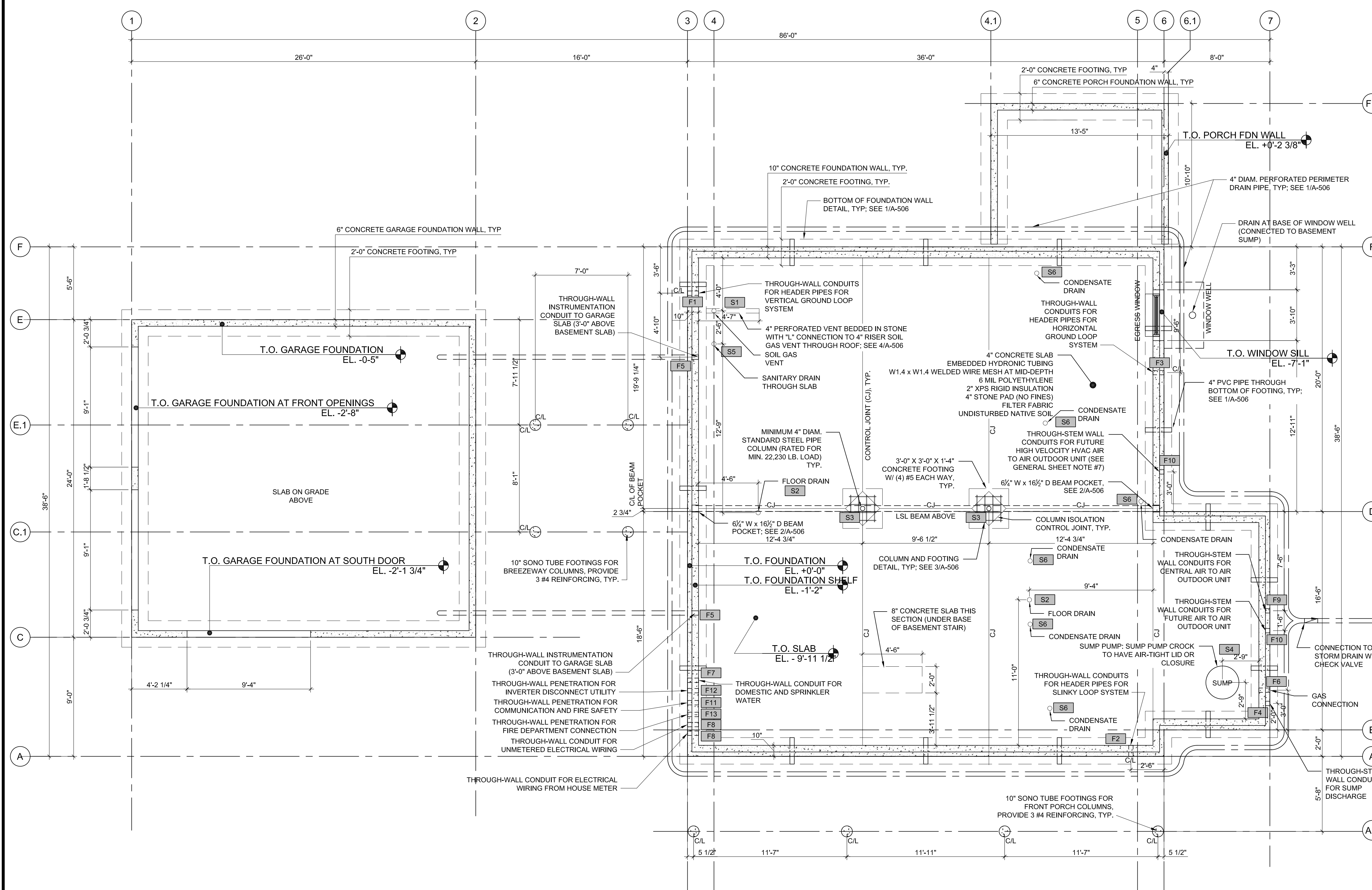

GENERAL SHEET NOTES

- BASEMENT FOUNDATION WALL TO HAVE (1) #4 HORIZONTAL REINFORCEMENT W/ MATCHING CORNER BAR AT TOP AND (1) AT EACH MIDDLE THIRD, AND (1) #4 VERTICAL REINFORCEMENT AT 48" O.C. LOCATED WITH 1-1/4" CONCRETE COVER MEASURED FROM THE INSIDE FACE OF THE FOUNDATION WALL.
- LOCATE 4" CONNECTION PIPE THROUGH BASE OF FOOTING WITHIN 5' OF EVERY CORNER AND EVERY 15' MAX ALONG LENGTH OF WALL SEGMENT WITH MIN OF 1 PER WALL SEGMENT.
- LOCATE CONDENSATE DRAINS BASED ON LAYOUT OF MECHANICAL EQUIPMENT
- SEE A-506 FOR FOUNDATION DETAILS.
- SEE A-603 FOR PENETRATION SCHEDULE.
- EL. +0'-0" IN THE ARCHITECTURAL DRAWINGS CORRESPONDS TO 461.30' IN THE SITE/CIVIL DRAWINGS
- IF THE HIGH VELOCITY HVAC OPTION IS NOT AWARDED, THE PENETRATION FOR THE CONDUITS WILL NOT BE PROVIDED.

SHEET KEYNOTES

PENETRATION KEY

- S1. SOIL GAS VENT
- S2. FLOOR DRAIN
- S3. STEEL PIPE COLUMN
- S4. SUMP PUMP
- S5. SEWER CONNECTION
- S6. CONDENSATE DRAIN
- F1. VERTICAL GROUND LOOP SYSTEM
- F2. SLINKY LOOP SYSTEM
- F3. HORIZONTAL GROUND LOOP SYSTEM
- F4. SUMP PUMP OUTLET
- F5. INSTRUMENTATION CONDUIT
- F6. GAS CONNECTION
- F7. WATER CONNECTION
- F8. ELECTRICITY CONNECTION
- F9. AIR-TO-AIR OUTDOOR UNIT CONNECTION
- F10. FUTURE AIR-TO-AIR OUTDOOR UNIT CONNECTION
- F11. COMMUNICATION/FIRE SAFETY CONNECTION
- F12. INVERTER UTILITY DISCONNECT CONNECTION
- F13. FIRE DEPARTMENT CONNECTION

BUILDING SCIENCE CORPORATION



30 FOREST STREET SOMERVILLE, MA
 T: (978) 589-5100 F: (978) 589-5103
 www.buildingscience.com

CONSULTANT:

PROJECT:
National Institute of Standards and Technology
NET ZERO ENERGY RESIDENTIAL TEST FACILITY
 NIST Campus
 Gaithersburg, MD

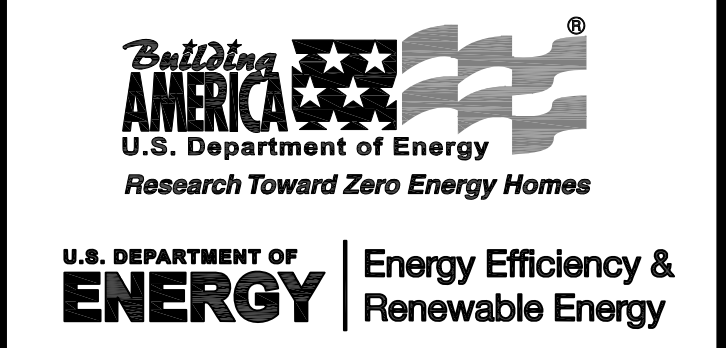

MARK	DATE	DESCRIPTION
	07/27/10	UPDATED
	06/29/10	UPDATED
ISSUE:	03/31/10	ISSUED FOR CONSTRUCTION

PROJECT NO: NIST NZERTF
 CAD DWG FILE: A-PLOT-PLAN-NZERTF
 DRAWN BY: CG
 CHECKED BY: BP
 COPYRIGHT © 2009
 BUILDING SCIENCE CORPORATION
 SHEET TITLE:

FOUNDATION PLAN

SCALE AS NOTED

A-102

1 FOUNDATION PLAN
 SCALE: 1/4" = 1'-0"

GENERAL SHEET NOTES

1. BASEMENT AREA TO OUTSIDE FACE OF FOUNDATION WALL: 1,518 SQ. FT.
2. SEE A-602 FOR FINISH SCHEDULE.

BUILDING SCIENCE CORPORATION



30 FOREST STREET SOMERVILLE, MA
 T: (978) 589-5100 F: (978) 589-5103
 www.buildingscience.com

CONSULTANT:

SHEET KEYNOTES

1. PROVIDE BLOCKING IN WALL TO SUPPORT FUTURE STAIR LIFT. BLOCKING SHOULD EXTEND UP TO A HEIGHT OF 3'-0" ABOVE STAIR TREADS.
2. STAIR FROM BASEMENT TO FIRST FLOOR TO HAVE 16 RISERS AT 6-2/3", 15 TREADS AT 10" WITH 1/2" NOSING.

PROJECT:

National Institute of Standards and Technology

NET ZERO ENERGY RESIDENTIAL TEST FACILITY

NIST Campus
 Gaithersburg, MD



U.S. DEPARTMENT OF ENERGY | Energy Efficiency & Renewable Energy

MARK	DATE	DESCRIPTION
ISSUE:	03/31/10	ISSUED FOR CONSTRUCTION

PROJECT NO: NIST NZERTF
 CAD DWG FILE: A-PLOT-PLAN-NZERTF
 DRAWN BY: CG
 CHECKED BY: BP

COPYRIGHT © 2009
 BUILDING SCIENCE CORPORATION

SHEET TITLE:

BASEMENT PLAN

SCALE AS NOTED

A-103

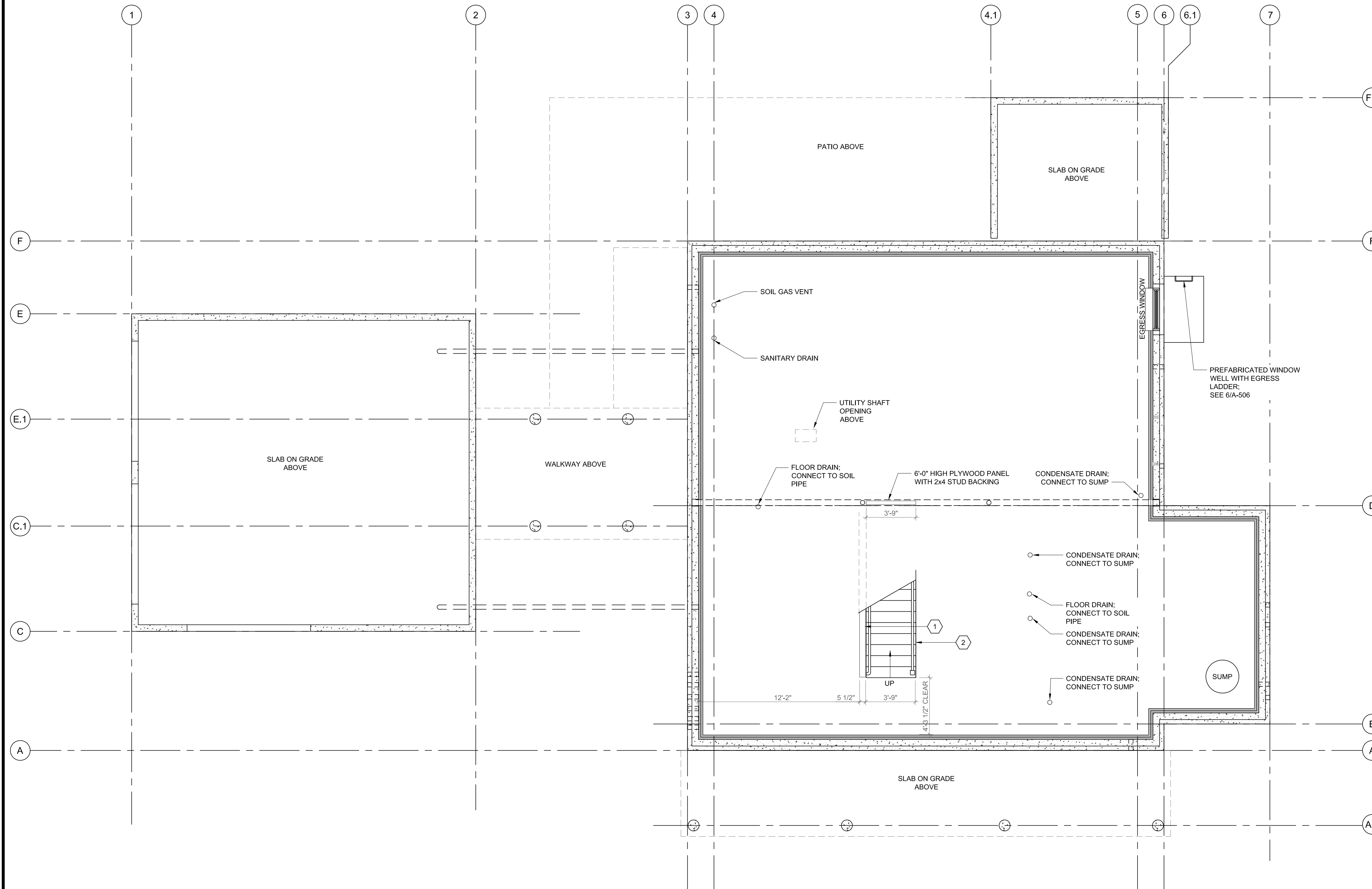

1 BASEMENT PLAN
 SCALE: 1/4" = 1'-0"

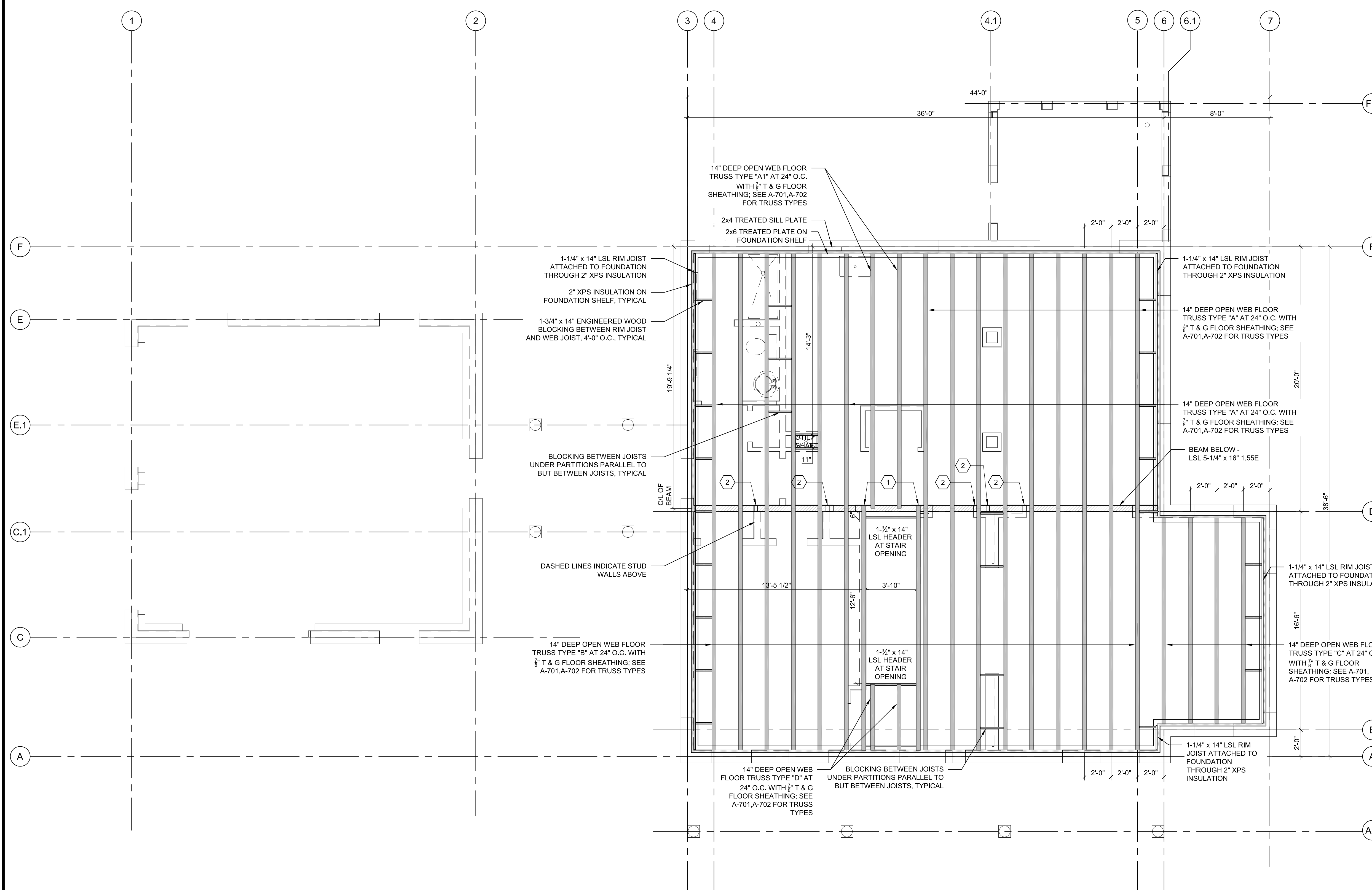

GENERAL SHEET NOTES

1. CONTRACTOR TO VERIFY ENGINEERED WOOD PRODUCT (EWP) MEMBER SIZES WITH EWP SUPPLIER.
2. EWP CONNECTIONS TO FOLLOW EWP SUPPLIER INSTRUCTIONS.
3. LIMIT THE OVERALL ESTIMATED WASTE FACTOR ON THE FRAMING ORDER TO 10% OR LESS.
4. PROVIDE ENGINEERED WOOD BLOCKING BETWEEN JOISTS UNDER PARTITIONS PARALLEL TO, BUT BETWEEN, JOISTS; COORDINATE LOCATION OF BLOCKING WITH MECHANICAL DUCTWORK.
5. SEE A-701 AND A-702 FOR OPEN WEB FLOOR JOIST TYPES; OPEN WEB FLOOR JOISTS TO BE CONSTRUCTED USING FSC-CERTIFIED WOOD; OPEN WEB FLOOR JOISTS TO BE ENGINEERED BY TRUSS SUPPLIER TO MEET LOCAL CODE.
6. GENERAL STRUCTURAL FRAMING CONNECTIONS:
 LSL CEILING JOISTS TO FLOOR HEADERS: USP THD179 ENGINEERED WOOD JOIST HANGER;
 DOUBLE LSL FLOOR HEADER TO TRIMMER: USP HD 410 DOUBLE HANGER.
7. STRUCTURAL FRAMING CONNECTIONS FOR CENTER BEARING WALL (TO RESIST ROOF UPLIFT):
 RAFTER TO RIDGE BOARD: USP AC7 ANGLE BRACKET WITH 4 10d NAILS EACH LEG
 RAFTER TO STUD IN ATTIC BEARING WALL: USP LTW12 WITH R 10d NAILS EACH END
 STUD IN ATTIC BEARING WALL TO CEILING JOIST: USP LTW12 WITH 4 10d NAILS EACH END
 CEILING JOIST TO STUD IN SECOND FLOOR BEARING WALL: USP RT10 WITH 4 8d NAILS EACH END (USE USP LTW12 AT CONNECTIONS TO WALL HEADERS)
 STUD TO SOLE PLATE IN SECOND FLOOR BEARING WALL: (2) USP S01 CLIP ANCHORS
 SOLE PLATE TO FLOOR DECK: (2) #8x3" WOOD SCREWS AT 12" O.C.
 ATTIC FLUSH-FRAMED BEAM TO WALL STUDS AT ENDS OF BEAM: USP LTW12 WITH 6 10d NAILS EACH END OF STRAP; PROVIDE CONTINUOUS LOAD PATH DOWN TO BASEMENT BEAM USING SIMILAR SIZED STRAPS AT ALL FRAMING JOINTS.

SHEET KEYNOTES

1. END OF FLOOR JOIST TO BE FULL BEARING ON BEAM BELOW.
2. 2-2x6 BLOCKS IN FLOOR BELOW JACK STUDS TO TRANSFER LOAD TO BEAM BELOW WHERE JACK STUDS ARE NOT ALIGNED WITH FLOOR JOIST.

BUILDING SCIENCE CORPORATION



30 FOREST STREET SOMERVILLE, MA
 T: (978) 589-5100 F: (978) 589-5103
 www.buildingscience.com

CONSULTANT:

PROJECT:
National Institute of Standards and Technology

NET ZERO ENERGY RESIDENTIAL TEST FACILITY

NIST Campus
 Gaithersburg, MD



U.S. DEPARTMENT OF ENERGY | Energy Efficiency & Renewable Energy

MARK	DATE	DESCRIPTION
ISSUE:	03/31/10	ISSUED FOR CONSTRUCTION

PROJECT NO: NIST NZERTF
 CAD DWG FILE: A-PLOT-PLAN-NZERTF
 DRAWN BY: CG
 CHECKED BY: BP

COPYRIGHT © 2009
 BUILDING SCIENCE CORPORATION
 SHEET TITLE:

FIRST FLOOR FRAMING PLAN

SCALE AS NOTED

A-104

FIRST FLOOR FRAMING PLAN
 SCALE: 1/4" = 1'-0"

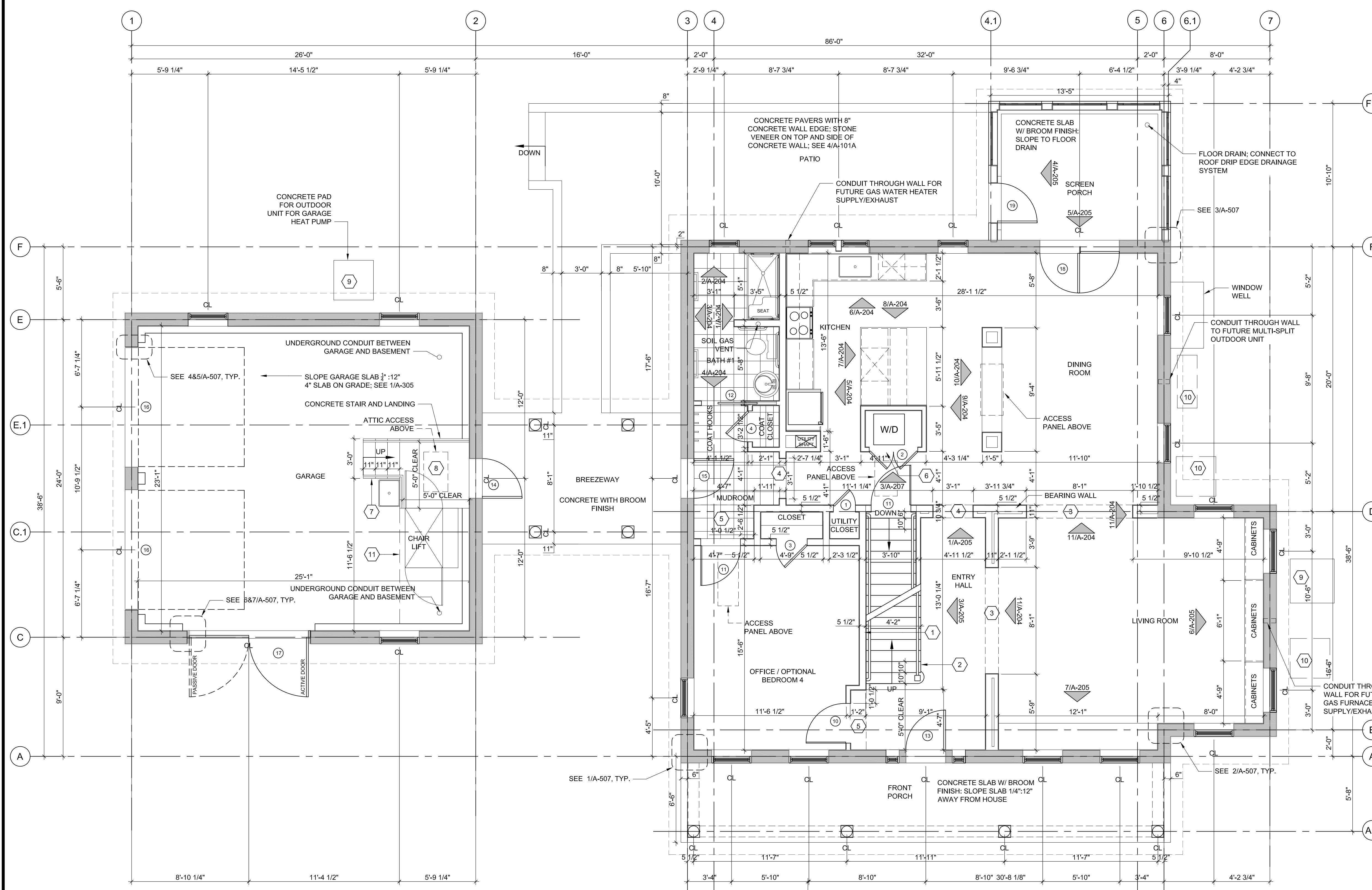

GENERAL SHEET NOTES

- FIRST FLOOR AREA TO OUTSIDE FACE OF STUD WALL: 1,518 SQ. FT.
- DIMENSIONS ARE TO FACE OF STUD UNLESS OTHERWISE NOTED.
- INTERIOR PARTITIONS FRAMED WITH 2x4 WOOD STUDS UNLESS OTHERWISE NOTED.
- INTERIOR BEARING WALLS FRAMED WITH 2x6 WOOD STUDS UNLESS OTHERWISE NOTED.
- INTERIOR DOORS TO BE CENTERED BETWEEN THE NEAREST WALL PERPENDICULAR ON EACH SIDE OF THE DOOR UNLESS OTHERWISE NOTED.
- SEE A-602 FOR FINISH SCHEDULE
- REFER TO POCKET DOOR FRAME KIT INSTALLATION INSTRUCTIONS TO DETERMINE ROUGH OPENING OF POCKET DOOR.

SHEET KEYNOTES

- PROVIDE BLOCKING IN WALL TO SUPPORT FUTURE STAIR LIFT. BLOCKING SHOULD EXTEND UP TO A HEIGHT OF 3'-0" ABOVE STAIR TREADS.
- STAIR FROM FIRST TO SECOND FLOOR TO HAVE 16 RISERS AT 7 1/2", 10" TREADS WITH 1/2" NOSING.
- CASED OPENING, 7'-6" FINISHED HEIGHT
- CASED OPENING, 6'-8" FINISHED HEIGHT
- DROPPED CEILING, 7'-9" FINISHED HEIGHT
- 18" x 18" ACCESS PANEL ABOVE DOOR FOR ACCESS TO FCU-2 UNIT.
- CONCRETE GARAGE STAIR TO HAVE 4 RISERS AT 6 1/2", 11" TREADS.
- GARAGE ATTIC ACCESS PANEL TO FIT WITHIN ROOF TRUSSES; SEE A-112 ROOF FRAMING PLAN FOR LOCATION AND SIZE. PANEL TO BE FASTENED FROM BELOW AND REMOVABLE WITHOUT REMOVING PANEL TRIM. ACCESS PANEL TO BE INSULATED. CELLULOSE ATTIC INSULATION SHALL BE HELD BACK FROM ACCESS OPENING.
- SIZE OF CONCRETE PAD TO BE SPECIFIED BY MANUFACTURER OF AIR-TO-AIR OUTDOOR UNIT.
- LOCATION OF FUTURE OUTDOOR AIR-TO-AIR UNIT.
- DO NOT SLOPE SLAB IN THIS AREA; THICKEN SLAB UNDER CHAIR LIFT IF SPECIFIED BY MANUFACTURER OF LIFT.

DOOR KEY

- 1'-8" x 6'-8" LH
- (2) 1'-10" x 6'-8"
- 2'-4" x 6'-8" LH
- 2'-4" x 6'-8" RH
- 2'-4" x 6'-8" POCKET
- 2'-6" x 6'-8" RH
- 2'-6" x 6'-8" LH
- 2'-8" x 6'-8" LH
- 2'-8" x 6'-8" RH
- 3'-0" x 6'-8" LH
- 3'-0" x 6'-8" RH
- 3'-0" x 6'-8" POCKET
- 3'-0" x 7'-0" RH W/ 12" SIDELITES
- 3'-0" x 7'-0" LH
- 3'-0" x 7'-0" RH
- 9'-0" x 8'-0" OVERHEAD
- (2) 4'-6" x 8'-0"
- 6'-0" x 6'-8" (1) LH PANEL, (1) FIXED PANEL
- 3'-0" x 6'-8" RH

BUILDING SCIENCE CORPORATION



30 FOREST STREET SOMERVILLE, MA
 T: (978) 589-5100 F: (978) 589-5103
 www.buildingscience.com

CONSULTANT:

PROJECT:
National Institute of Standards and Technology
NET ZERO ENERGY RESIDENTIAL TEST FACILITY
 NIST Campus Gaithersburg, MD

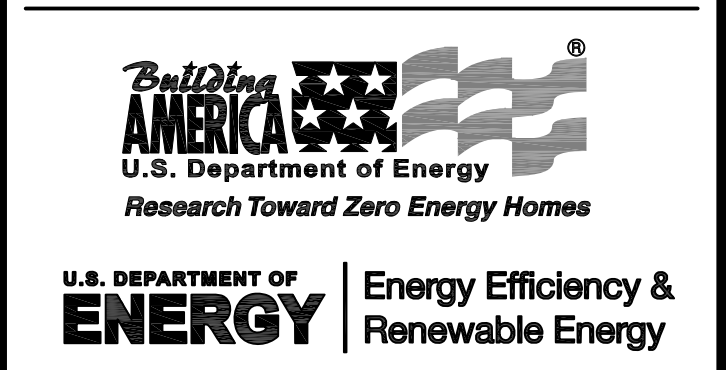

MARK	DATE	DESCRIPTION
	07/27/10	UPDATED
	06/29/10	UPDATED
ISSUE:	03/31/10	ISSUED FOR CONSTRUCTION

PROJECT NO: NIST NZERTF
 CAD DWG FILE: A-PLOT-PLAN-NZERTF
 DRAWN BY: CG
 CHECKED BY: BP
 COPYRIGHT © 2009 BUILDING SCIENCE CORPORATION
 SHEET TITLE:

FIRST FLOOR PLAN

SCALE AS NOTED

A-105

1 FIRST FLOOR PLAN
 SCALE: 1/4" = 1'-0"

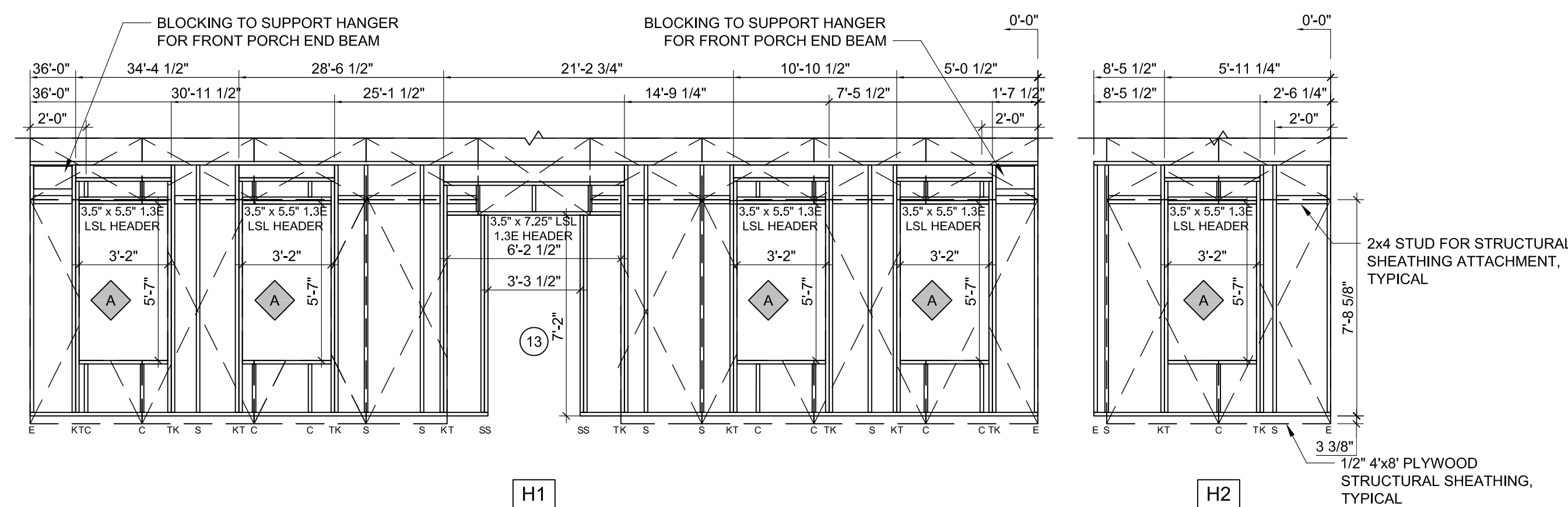
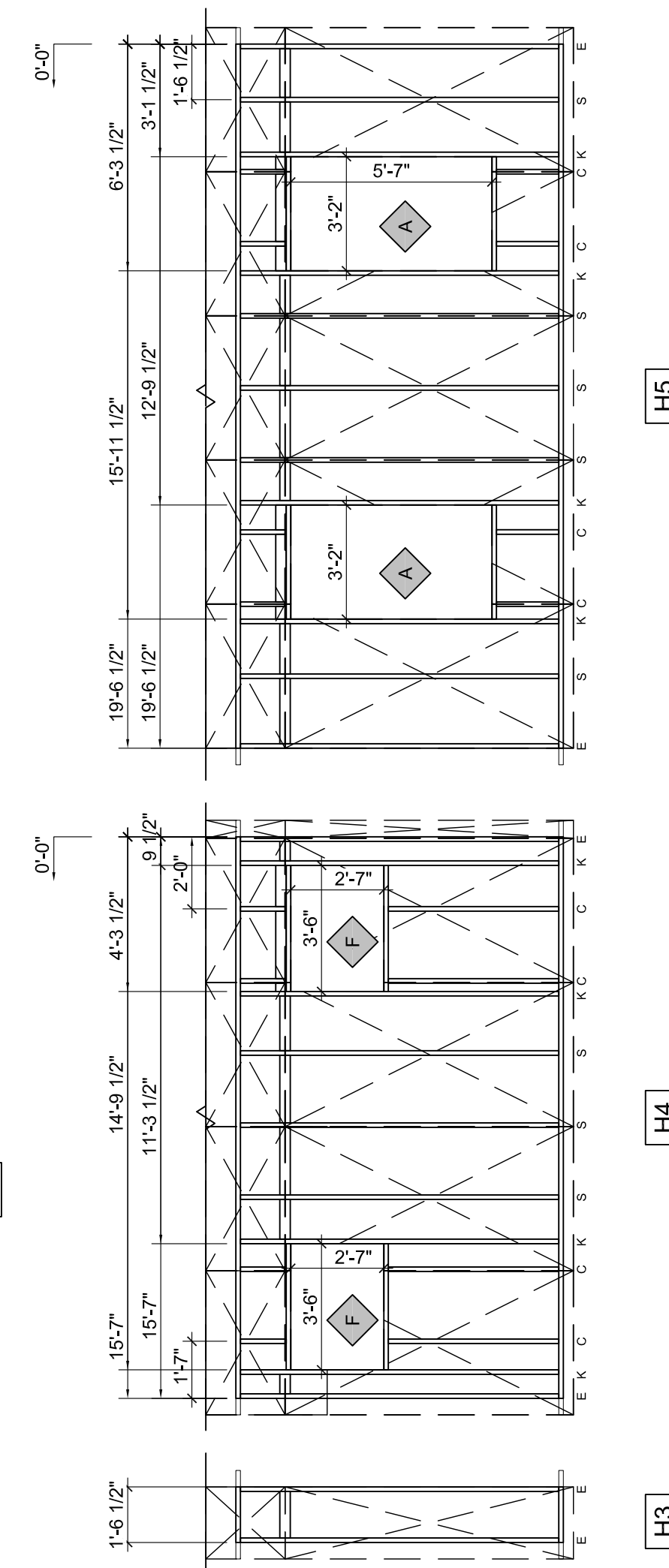
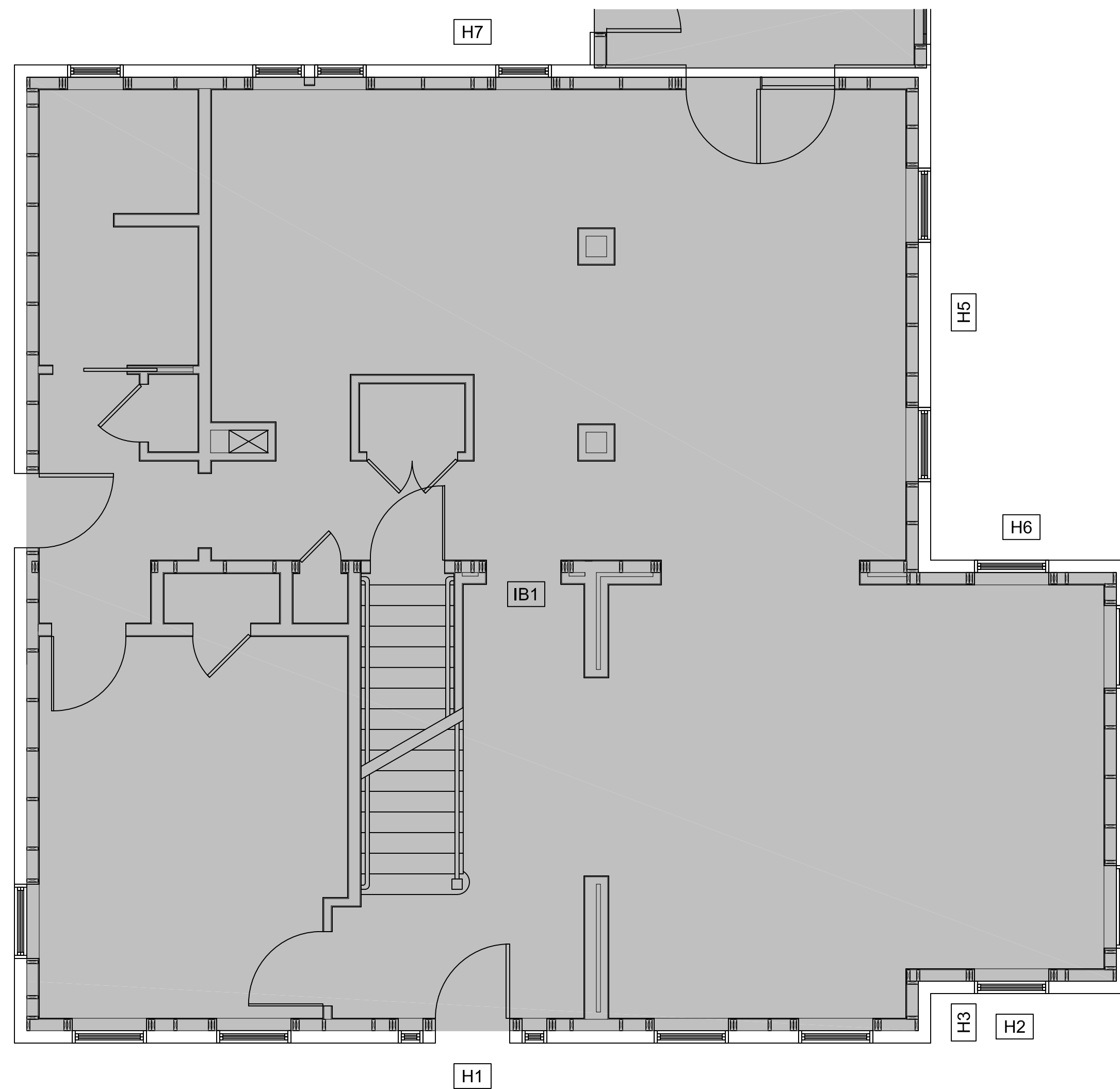
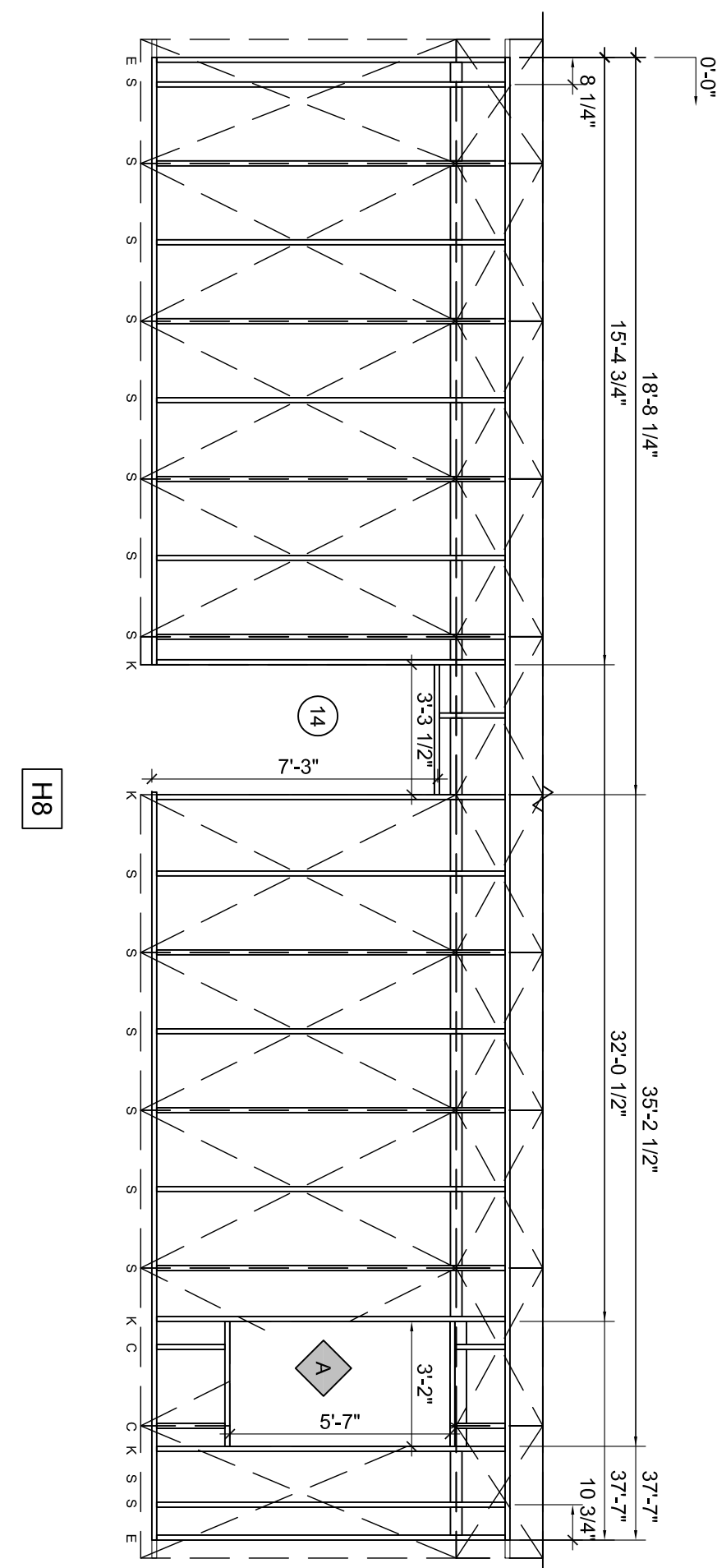
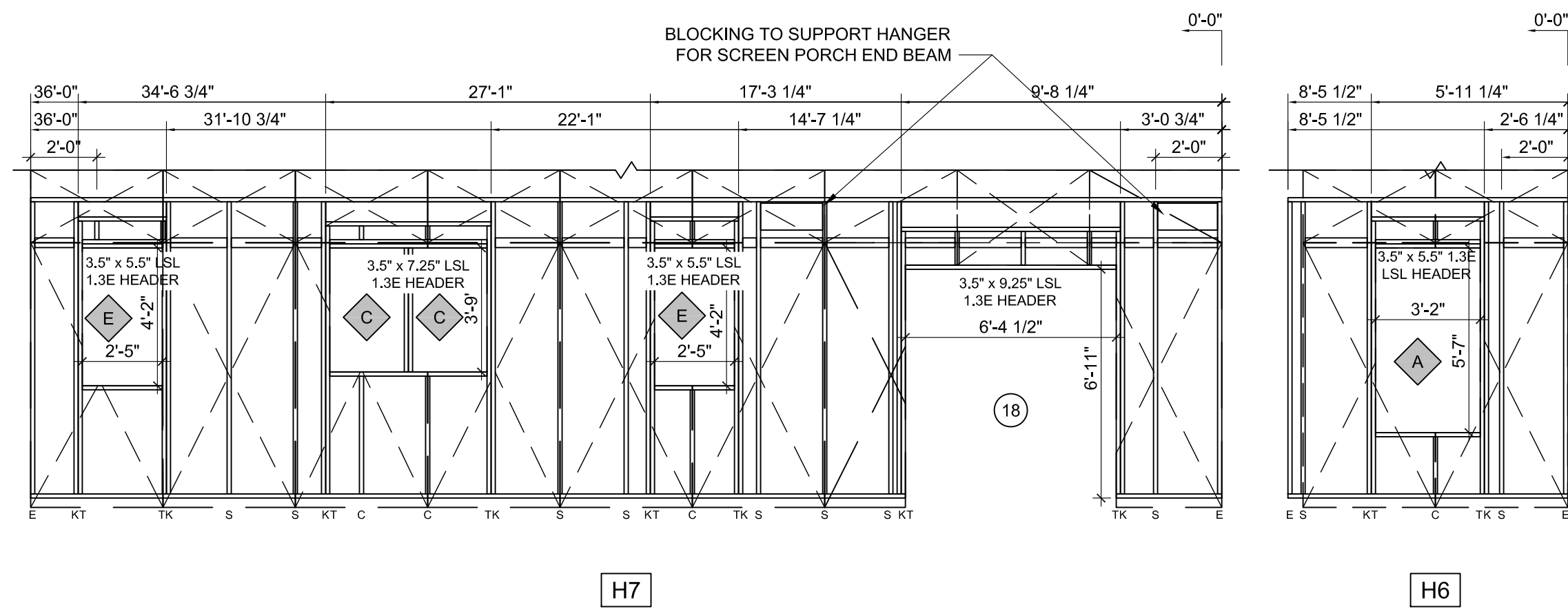
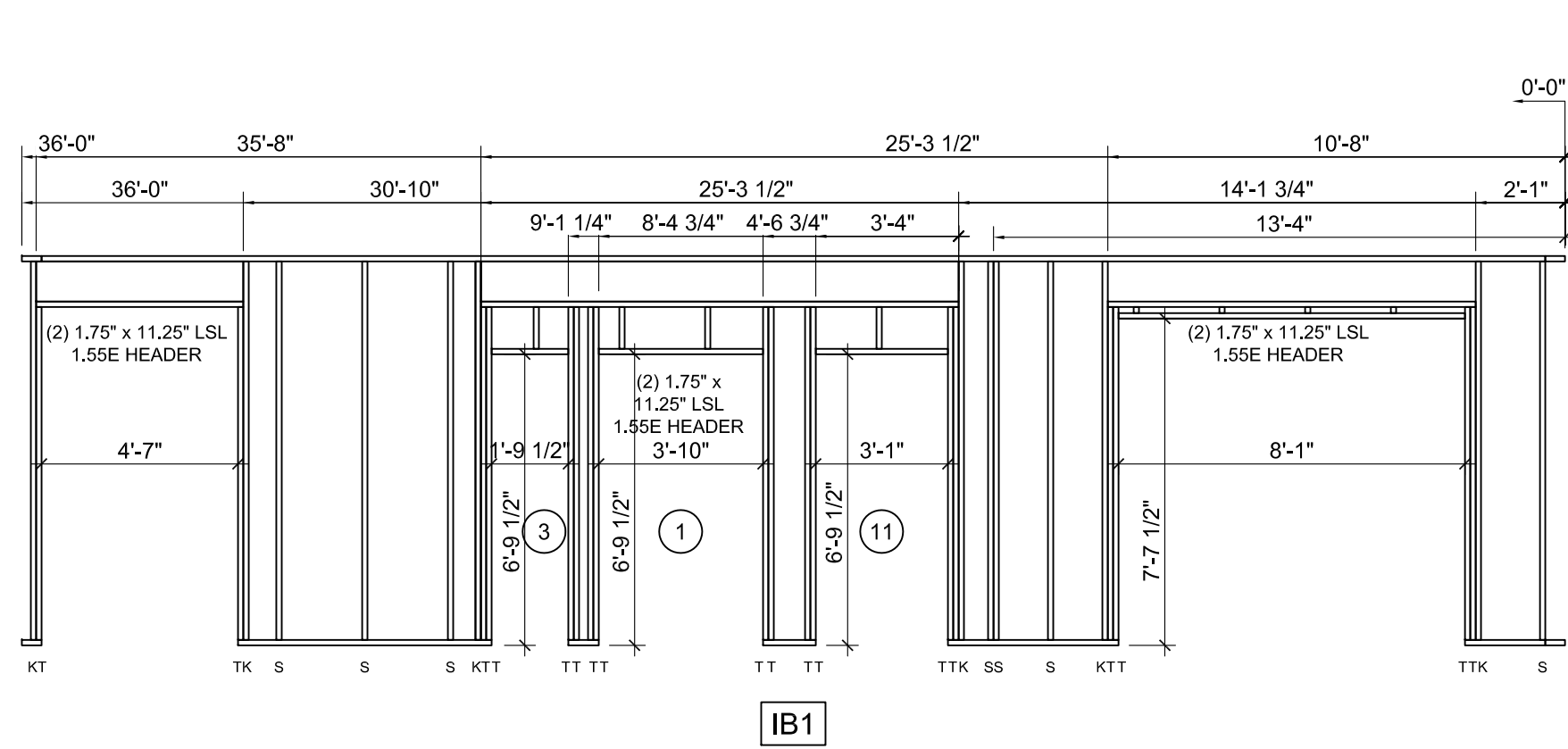

GENERAL SHEET NOTES

- REAR WALL FRAMING ELEVATIONS DRAWN AS SEEN FROM INTERIOR; INTERIOR BEARING WALL FRAMING ELEVATION DRAWN AS SEEN FROM THE FRONT; ALL OTHER ELEVATIONS DRAWN AS SEEN FROM EXTERIOR
- TYPICAL WALL HEIGHT = 9'-1"
- TYPICAL FIRST FLOOR WINDOW FRAMING HEAD HEIGHT = 7'-6 3/4"
- WINDOW AND EXTERIOR DOOR FRAMING OPENING DIMENSIONS TO BE ADJUSTED PER MANUFACTURER SELECTION AS FOLLOWS:
 - A. FRAMING WIDTH FOR DOORS AND WINDOWS: INCREASE THE MANUFACTURER'S SPECIFIED ROUGH OPENING WIDTH BY ADDING 1/2" TO EACH SIDE.
 - B. FRAMING HEIGHT FOR WINDOWS: INCREASE THE MANUFACTURER'S SPECIFIED ROUGH OPENING HEIGHT BY ADDING 1/2" TO THE TOP AND 1" TO THE BOTTOM.
 - C. FRAMING HEIGHT FOR DOORS: INCREASE THE MANUFACTURER'S SPECIFIED ROUGH OPENING HEIGHT BY ADDING 1/2" TO THE TOP.
- FRAMING STUDS TO BE FSC-CERTIFIED LUMBER.
- LIMIT THE OVERALL ESTIMATED WASTE FACTOR ON THE FRAMING ORDER TO 10% OR LESS.
- STRUCTURAL SHEATHING CONNECTIONS (TO RESIST ROOF UPLIFT):
 - LAP SHEATHING ON RAFTER RIM BOARD: MINIMUM 8d NAILS AT 3" O.C.
 - HORIZONTAL SHEATHING EDGES AT BLOCKING OR FRAMING: MINIMUM 8d NAILS AT 3" O.C.
 - HORIZONTAL SHEATHING EDGES BELOW SECOND FLOOR: MINIMUM 8d NAILS AT 6" O.C.

SHEET KEYNOTES

BUILDING SCIENCE CORPORATION

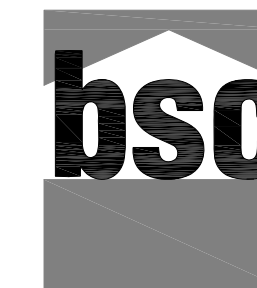

30 FOREST STREET SOMERVILLE, MA
T: (978) 589-5100 F: (978) 589-5103
www.buildingscience.com

CONSULTANT:

PROJECT:

National Institute of Standards and Technology

NET ZERO ENERGY RESIDENTIAL TEST FACILITY

NIST Campus
Gaithersburg, MD



U.S. DEPARTMENT OF ENERGY | Energy Efficiency & Renewable Energy

MARK	DATE	DESCRIPTION
ISSUE:	03/31/10	ISSUED FOR CONSTRUCTION

PROJECT NO: NIST NZERTF
CAD DWG FILE: A-PLOT-PLAN-NZERTF
DRAWN BY: HW
CHECKED BY: BP

COPYRIGHT © 2009
BUILDING SCIENCE CORPORATION
SHEET TITLE:

FIRST FLOOR KEY PLAN & WALL FRAMING ELEVATIONS

SCALE AS NOTED

A-106

1 FIRST FLOOR KEY PLAN & WALL FRAMING ELEVATIONS

SCALE: 1/4" = 1'-0"

GENERAL SHEET NOTES

- REAR WALL FRAMING ELEVATIONS DRAWN AS SEEN FROM INTERIOR; ALL OTHER ELEVATIONS DRAWN AS SEEN FROM EXTERIOR
- TYPICAL GARAGE WALL HEIGHT = 9'-4"
- TYPICAL GARAGE WINDOW FRAMING HEAD HEIGHT = 6'-10 1/2" ABOVE TOP OF GARAGE FOUNDATION WALL.
- WINDOW AND EXTERIOR DOOR FRAMING OPENING DIMENSIONS TO BE ADJUSTED PER MANUFACTURER SELECTION AS FOLLOWS:
 - FRAMING WIDTH FOR DOORS AND WINDOWS: INCREASE THE MANUFACTURER'S SPECIFIED ROUGH OPENING BY ADDING 1/2" TO EACH SIDE.
 - FRAMING HEIGHT FOR WINDOWS: INCREASE THE MANUFACTURER'S SPECIFIED ROUGH OPENING HEIGHT BY ADDING 1/2" TO THE TOP AND 1" TO THE BOTTOM.
 - FRAMING HEIGHT FOR DOORS: INCREASE THE MANUFACTURER'S ROUGH OPENING HEIGHT BY ADDING 1/2" TO THE TOP.
- FRAMING STUDS TO BE FSC-CERTIFIED LUMBER.
- LIMIT THE OVERALL ESTIMATED WASTE FACTOR ON THE FRAMING ORDER TO 10% OR LESS.
- STRUCTURAL SHEATHING CONNECTIONS ON GARAGE (FOR BRACING):
FASTEN PLYWOOD SHEATHING ON WEST WALL WITH MINIMUM 8d NAILS AT 3" O.C.

SHEET KEYNOTES

BUILDING SCIENCE CORPORATION

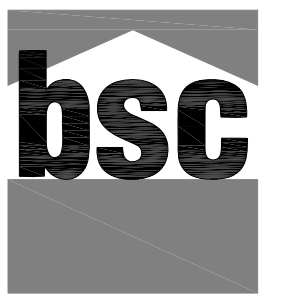

30 FOREST STREET SOMERVILLE, MA
T: (978) 589-5100 F: (978) 589-5103
www.buildingscience.com

CONSULTANT:

PROJECT:

National Institute of Standards and Technology

NET ZERO ENERGY RESIDENTIAL TEST FACILITY

NIST Campus
Gaithersburg, MD



U.S. DEPARTMENT OF ENERGY | Energy Efficiency & Renewable Energy

MARK	DATE	DESCRIPTION
ISSUE:	03/31/10	ISSUED FOR CONSTRUCTION

PROJECT NO: NIST NZERTF
CAD DWG FILE: A-PLOT-PLAN-NZERTF
DRAWN BY: HW
CHECKED BY: BP

COPYRIGHT © 2009
BUILDING SCIENCE CORPORATION

SHEET TITLE:

SCREEN PORCH & GARAGE KEY PLANS & WALL FRAMING ELEVATIONS

SCALE AS NOTED

A-107

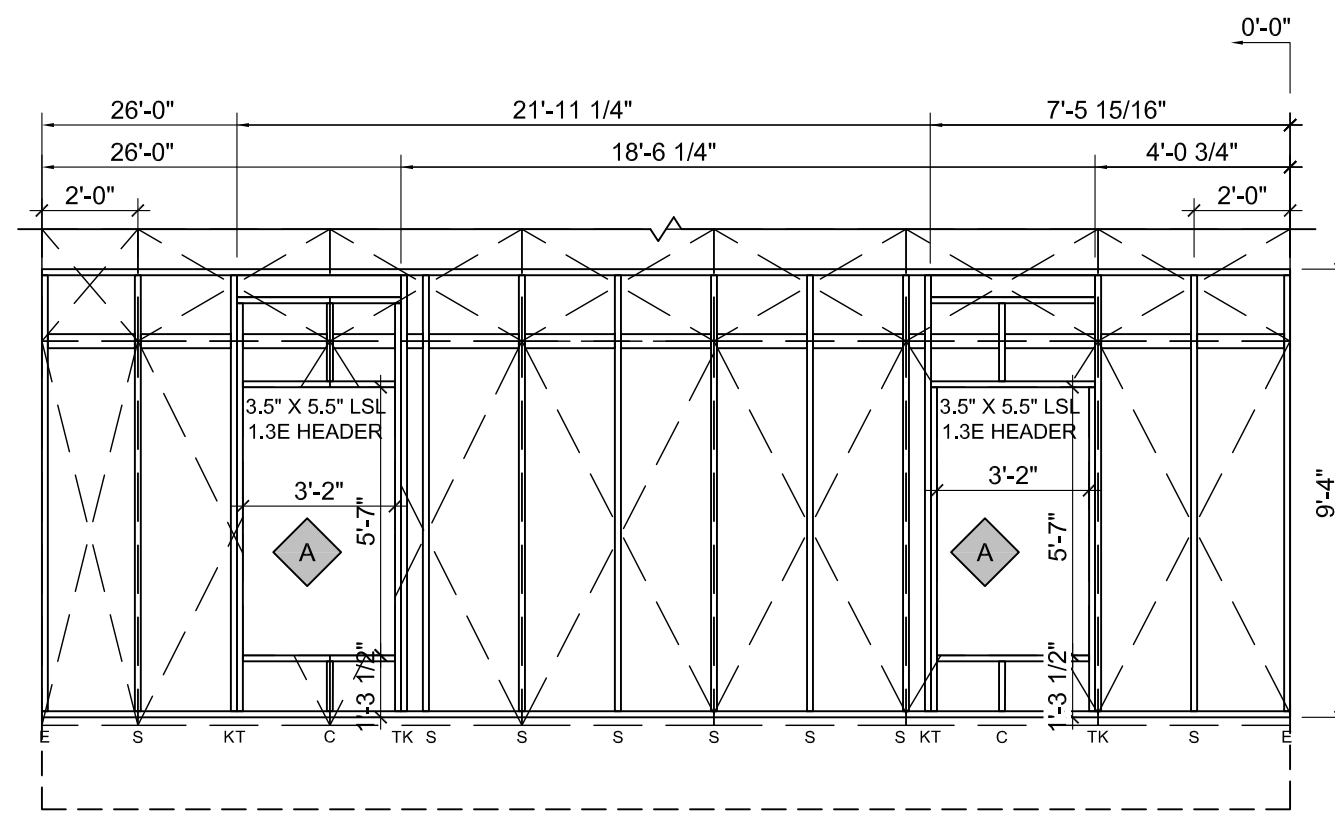

G3

G3

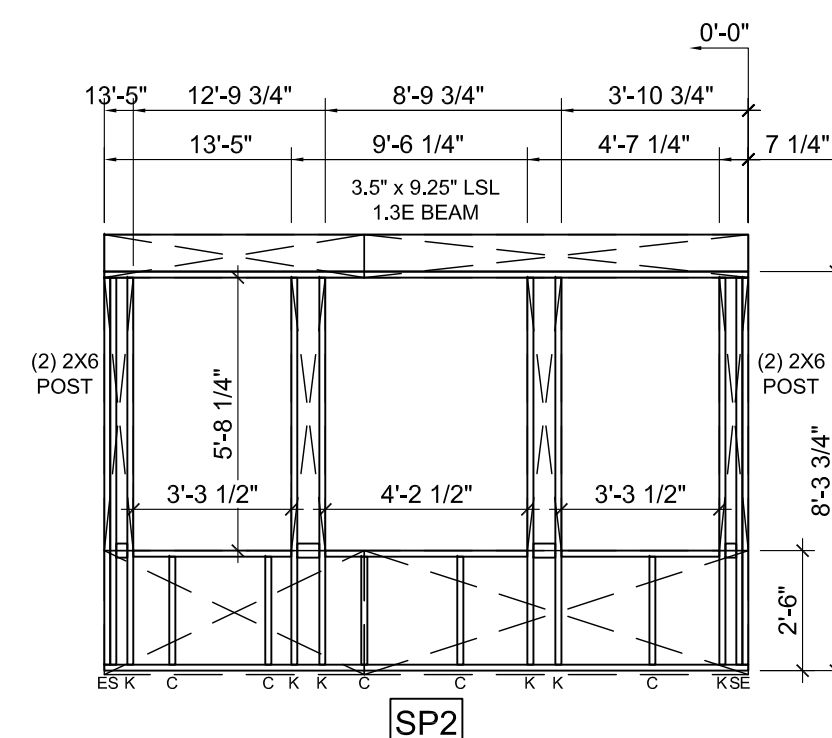
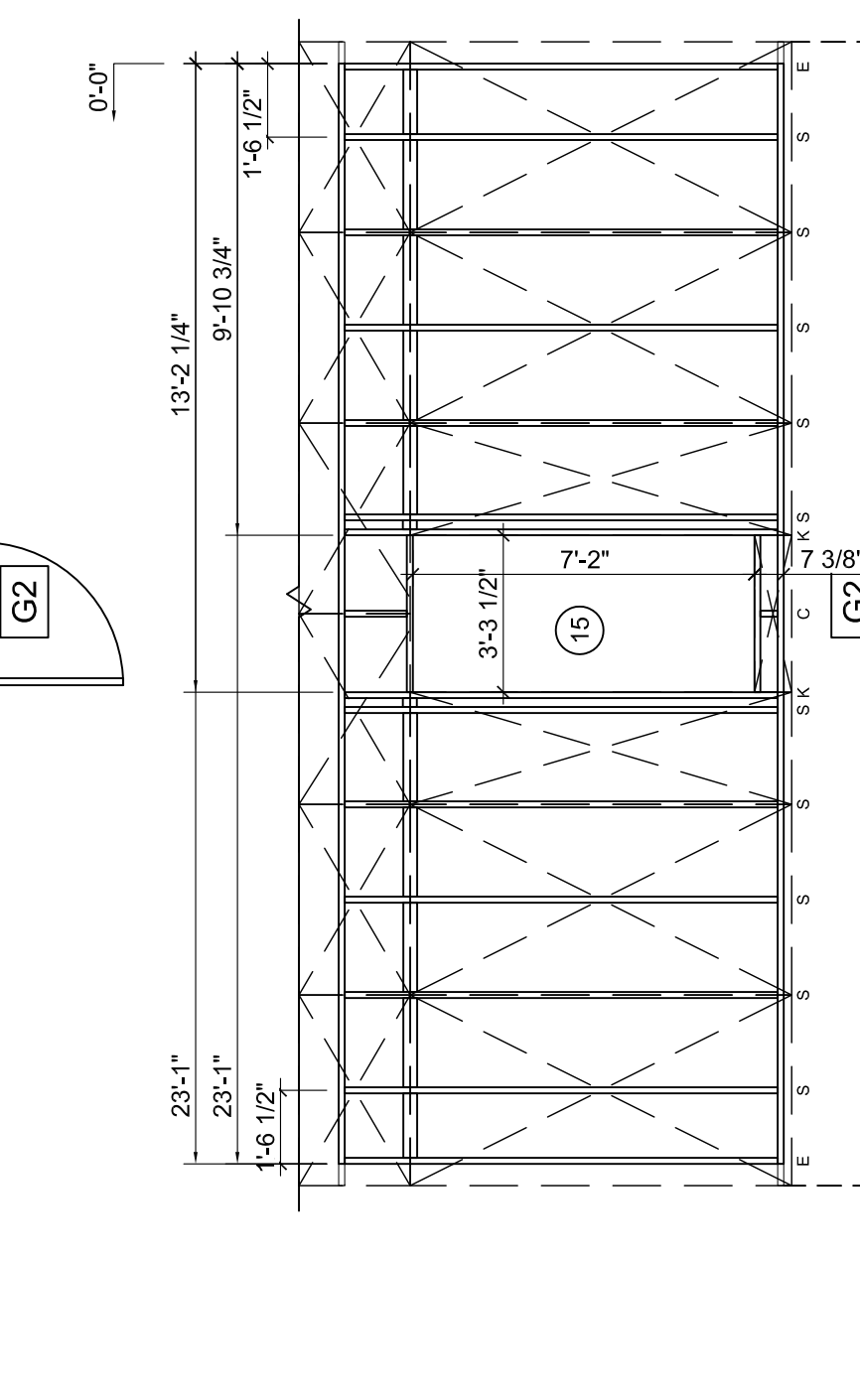
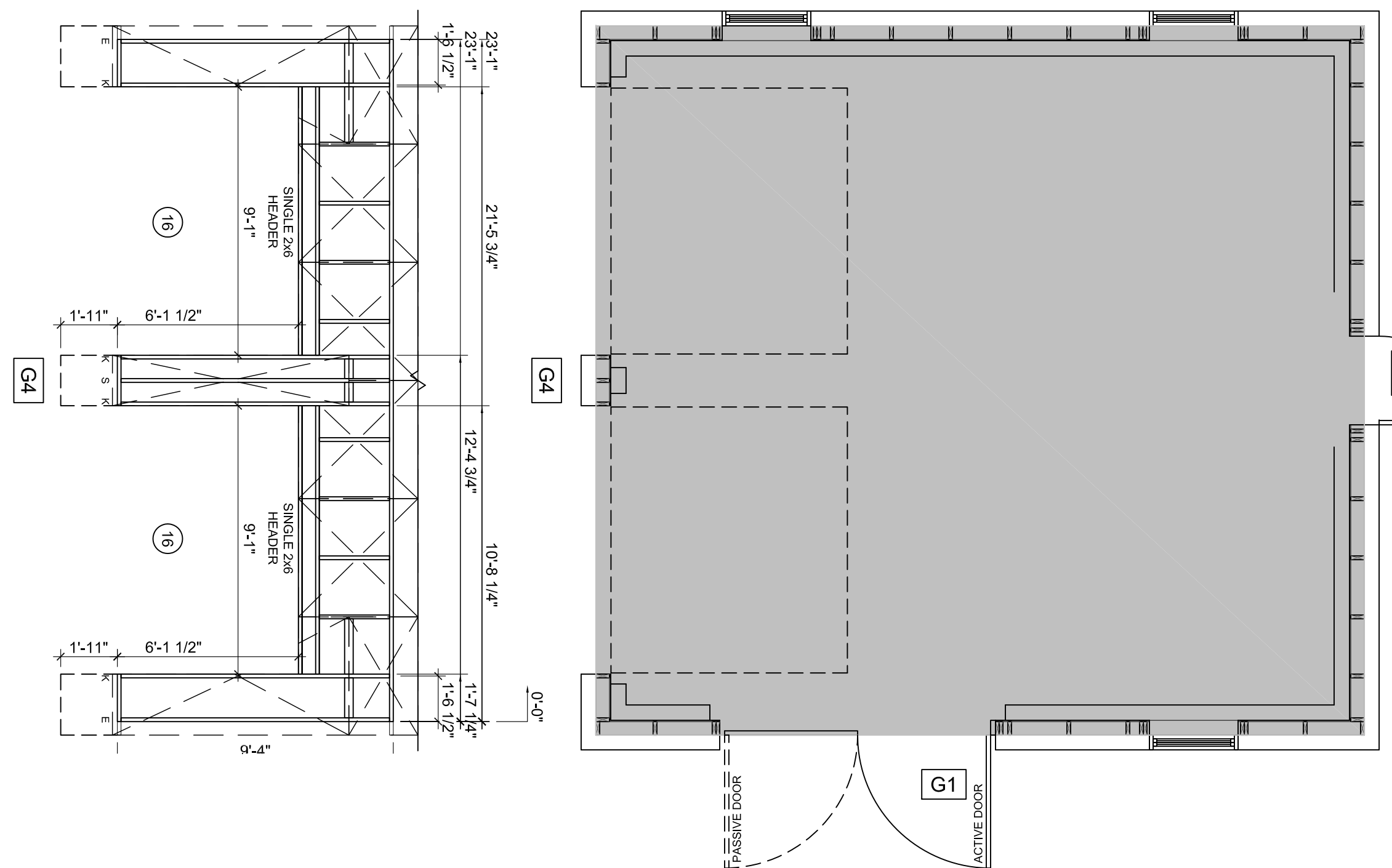

SP2

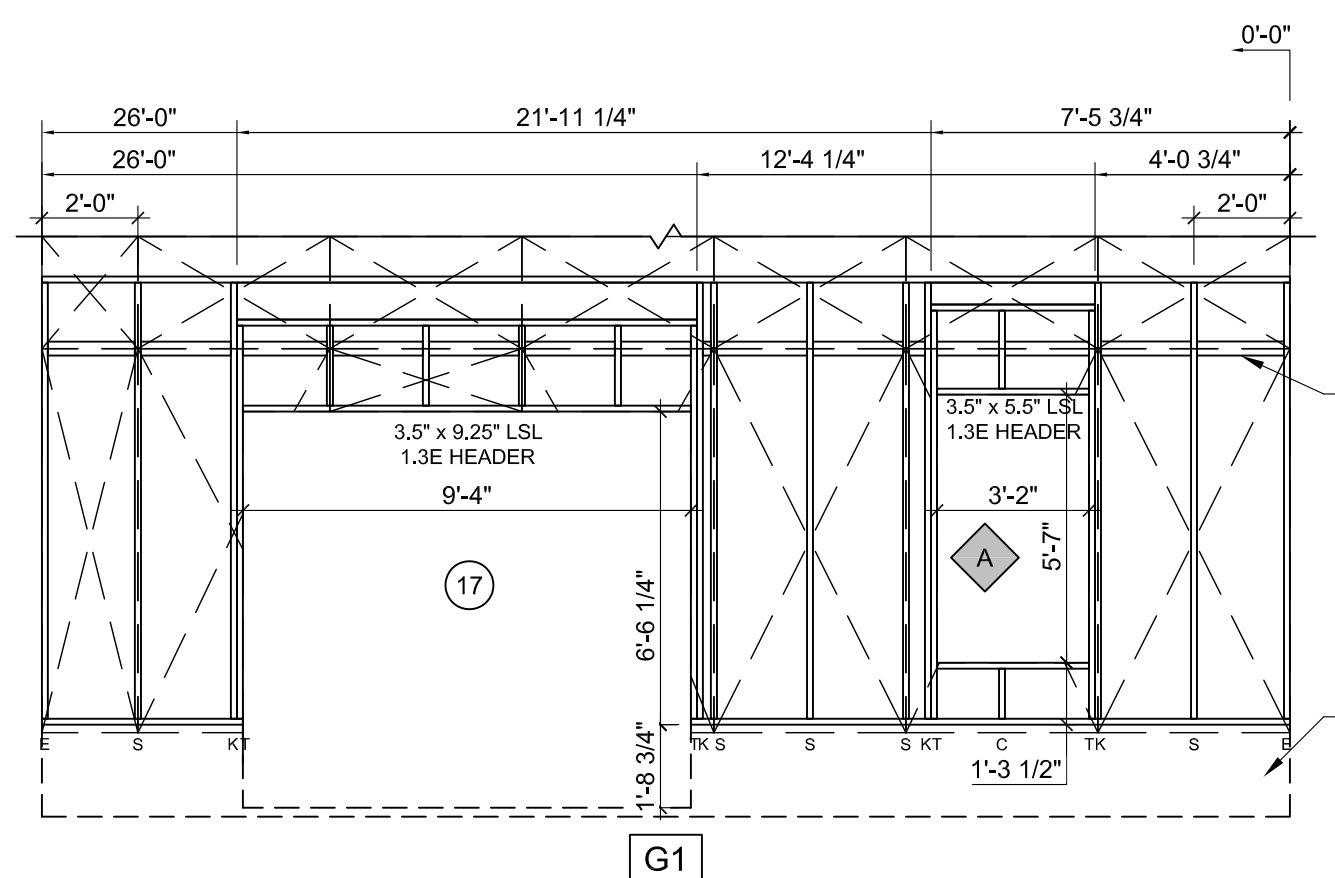

G1

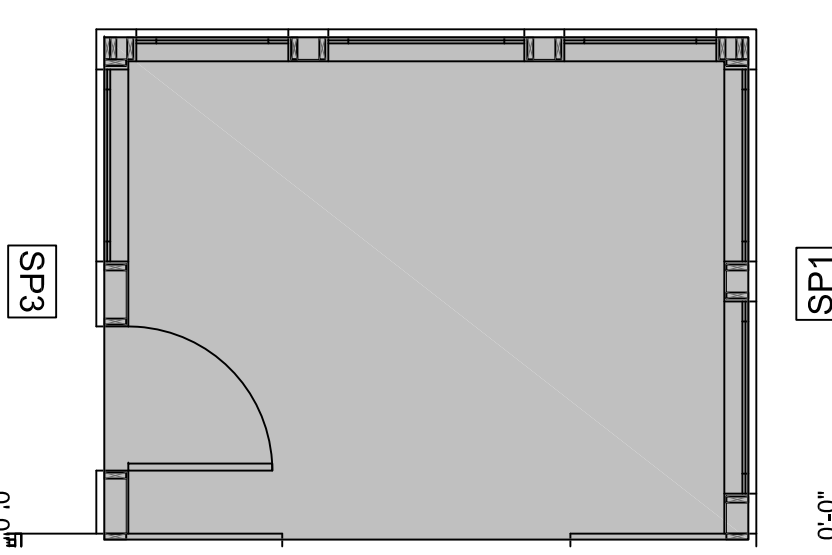
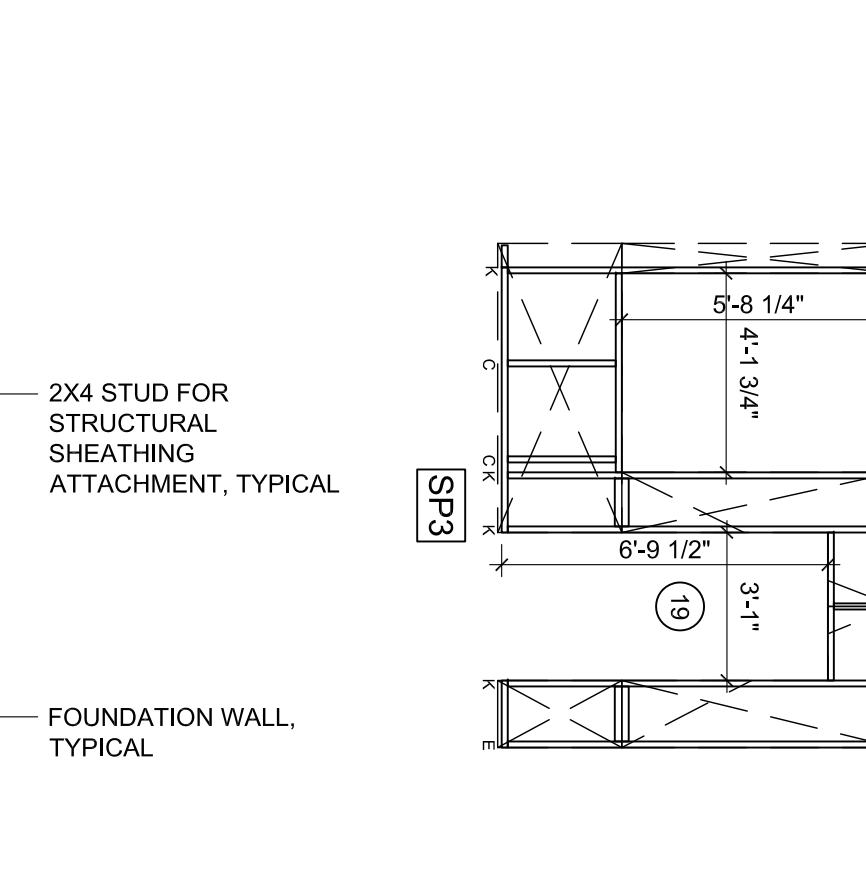

SP3

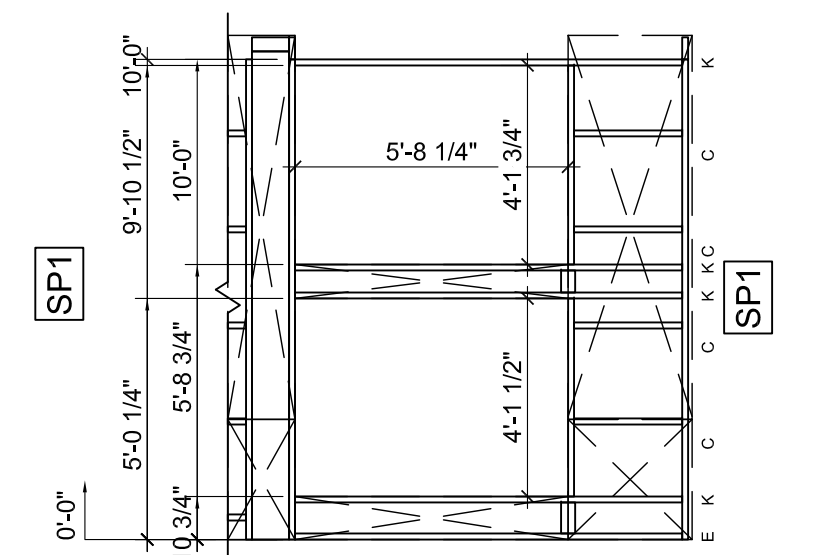

SP1

2 GARAGE KEY PLAN & WALL FRAMING ELEVATIONS
SCALE: 1/4" = 1'-0"

1 SCREEN PORCH KEY PLAN & WALL FRAMING ELEVATIONS
SCALE: 1/4" = 1'-0"

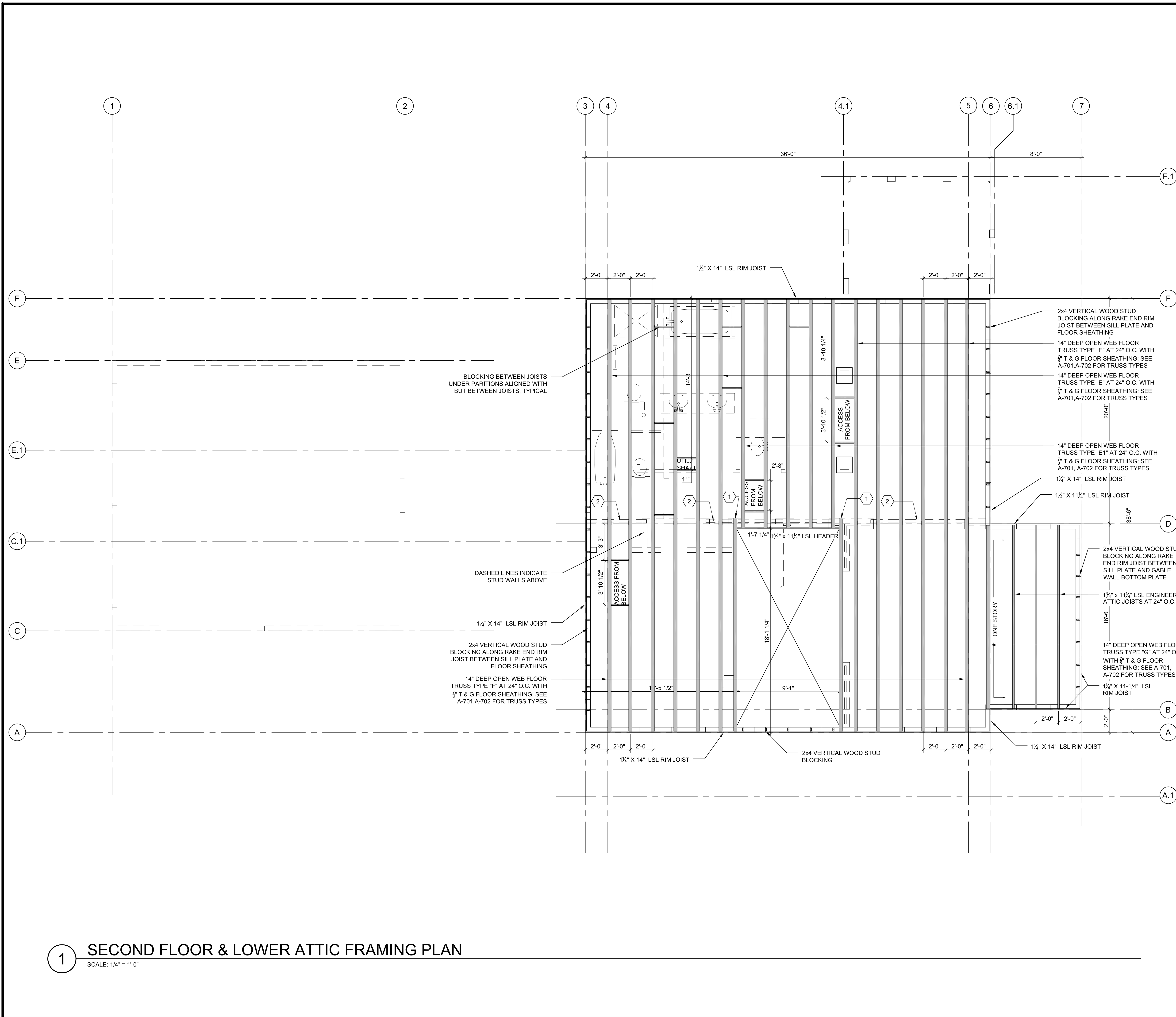

GENERAL SHEET NOTES

1. CONTRACTOR TO VERIFY ENGINEERED WOOD PRODUCT (EWP) MEMBER SIZES WITH EWP SUPPLIER.
2. EWP CONNECTIONS TO FOLLOW EWP SUPPLIER INSTRUCTIONS.
3. LIMIT THE OVERALL ESTIMATED WASTE FACTOR ON THE FRAMING ORDER TO 10% OR LESS.
4. PROVIDE ENGINEERED WOOD BLOCKING BETWEEN JOISTS UNDER PARTITIONS PARALLEL TO, BUT BETWEEN, JOISTS; COORDINATE LOCATION OF BLOCKING WITH MECHANICAL DUCTWORK.
5. SEE A-701 AND A-702 FOR OPEN WEB FLOOR JOIST TYPES; OPEN WEB FLOOR JOISTS TO BE CONSTRUCTED USING FSC-CERTIFIED WOOD; OPEN WEB FLOOR JOISTS TO BE ENGINEERED BY TRUSS SUPPLIER TO MEET LOCAL CODE.
6. GENERAL STRUCTURAL FRAMING CONNECTIONS:
 LSL CEILING JOISTS TO FLOOR HEADERS: USP THD179 ENGINEERED WOOD JOIST HANGER;
 DOUBLE LSL FLOOR HEADER TO TRIMMER: USP HD 410 DOUBLE HANGER.
 STRUCTURAL FRAMING CONNECTIONS FOR CENTER BEARING WALL (TO RESIST ROOF UPLIFT):
 RAFTER TO RIDGE BOARD: USP AC7 ANGLE BRACKET WITH 4 10d NAILS EACH LEG
 RAFTER TO STUD IN ATTIC BEARING WALL: USP LTW12 WITH R 10d NAILS EACH END
 STUD IN ATTIC BEARING WALL TO CEILING JOIST: USP LTW12 WITH 4 10d NAILS EACH END
 CEILING JOIST TO STUD IN SECOND FLOOR BEARING WALL: USP RT10 WITH 4 8d NAILS EACH END (USE USP LTW12 AT CONNECTIONS TO WALL HEADERS)
 STUD TO SOLE PLATE IN SECOND FLOOR BEARING WALL: (2) USP S01 CLIP ANCHORS
 SOLE PLATE TO FLOOR DECK: (2) #8x3" WOOD SCREWS AT 12" O.C.
 ATTIC FLUSH-FRAMED BEAM TO WALL STUDS AT ENDS OF BEAM: USP LTW12 WITH 8 10d NAILS EACH END OF STRAP; PROVIDE CONTINUOUS LOAD PATH DOWN TO BASEMENT BEAM USING SIMILAR SIZED STRAPS AT ALL FRAMING JOINTS.

SHEET KEYNOTES

1. END OF FLOOR JOIST TO BE FULL BEARING ON BEARING WALL BELOW.
2. FOR SIZE AND LOCATION OF HEADERS IN THE BEARING WALL BELOW, SEE A-108, WALL 1B1.

BUILDING SCIENCE CORPORATION

30 FOREST STREET SOMERVILLE, MA
 T: (978) 589-5100 F: (978) 589-5103
 www.buildingscience.com

CONSULTANT:

PROJECT:

National Institute of Standards and Technology

NET ZERO ENERGY RESIDENTIAL TEST FACILITY

NIST Campus
Gaithersburg, MD

U.S. Department of Energy
Research Toward Zero Energy Homes

U.S. DEPARTMENT OF ENERGY | Energy Efficiency & Renewable Energy

MARK	DATE	DESCRIPTION
ISSUE:	03/31/10	ISSUED FOR CONSTRUCTION

PROJECT NO: NIST NZERTF
 CAD DWG FILE: A-PLOT-PLAN-NZERTF
 DRAWN BY: CG
 CHECKED BY: BP

COPYRIGHT © 2009
 BUILDING SCIENCE CORPORATION

SECOND FLOOR & LOWER ATTIC FRAMING PLAN

SCALE AS NOTED

A-108

1 SECOND FLOOR & LOWER ATTIC FRAMING PLAN
 SCALE: 1/4" = 1'-0"

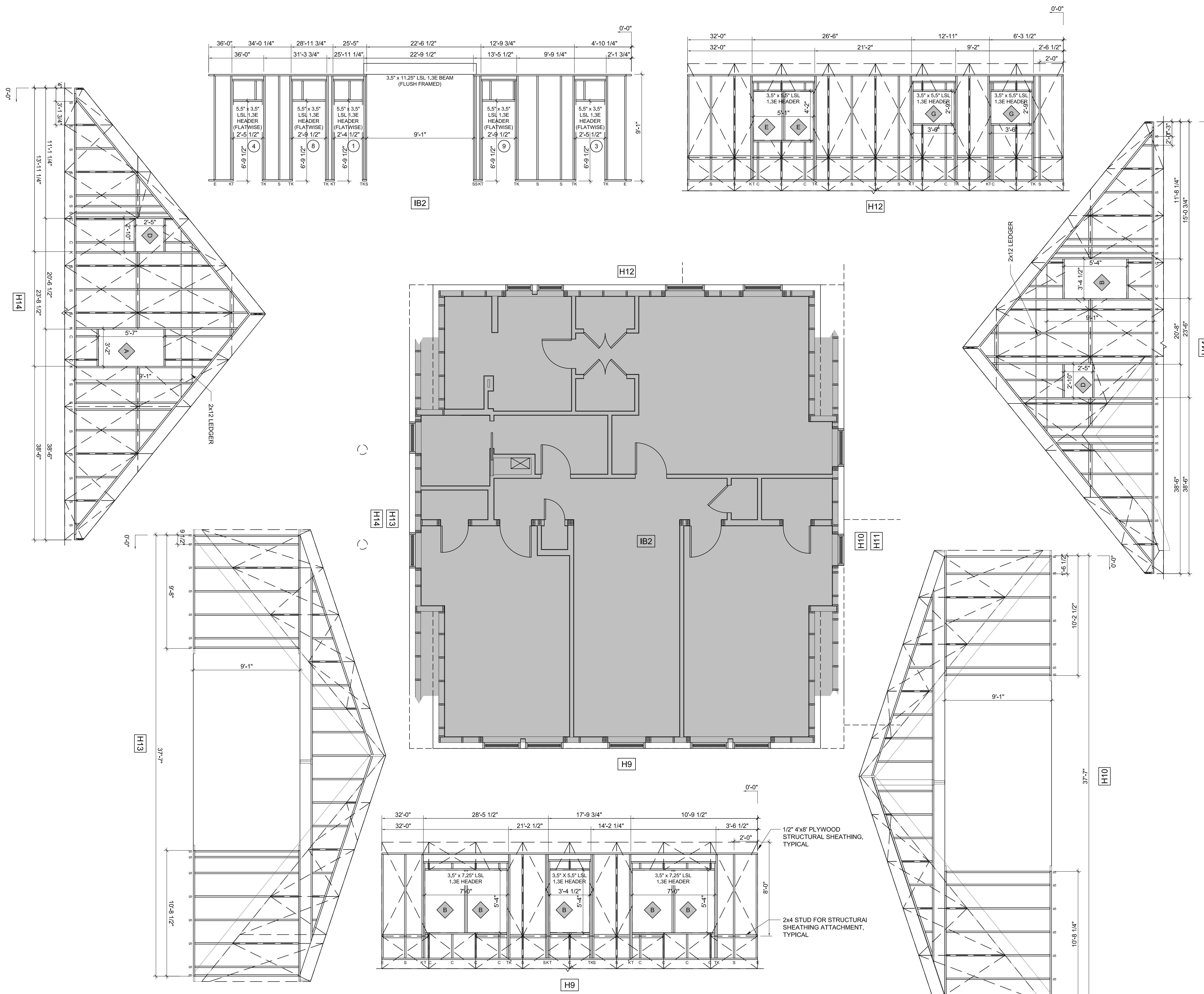

GENERAL SHEET NOTES

1. REAR WALL FRAMING ELEVATIONS DRAWN AS SEEN FROM INTERIOR; INTERIOR BEARING WALL FRAMING ELEVATION DRAWN AS SEEN FROM THE FRONT; ALL OTHER ELEVATIONS DRAWN AS SEEN FROM EXTERIOR
2. TYPICAL WALL HEIGHT = 9'-1"
3. TYPICAL SECOND FLOOR WINDOW FRAMING HEAD HEIGHT = 7'-7 1/2"
4. WINDOW AND EXTERIOR DOOR FRAMING OPENING DIMENSIONS TO BE ADJUSTED PER MANUFACTURER SELECTION AS FOLLOWS:
 - A. FRAMING WIDTH FOR DOORS AND WINDOWS: INCREASE THE MANUFACTURER'S SPECIFIED ROUGH OPENING WIDTH BY ADDING 1/2" TO EACH SIDE.
 - B. FRAMING HEIGHT FOR WINDOWS: INCREASE THE MANUFACTURER'S SPECIFIED ROUGH OPENING HEIGHT BY ADDING 1/2" TO THE TOP AND 1" TO THE BOTTOM.
 - C. FRAMING HEIGHT FOR DOORS: INCREASE THE MANUFACTURER'S SPECIFIED ROUGH OPENING HEIGHT BY ADDING 1/2" TO THE TOP.
5. FRAMING STUDS TO BE FSC-CERTIFIED LUMBER.
6. LIMIT THE OVERALL ESTIMATED WASTE FACTOR ON THE FRAMING ORDER TO 10% OR LESS.
7. STRUCTURAL SHEATHING CONNECTIONS (TO RESIST ROOF UPLIFT):
 - LAP SHEATHING ON RAFTER RIM BOARD: MINIMUM 8d NAILS AT 3" O.C.
 - HORIZONTAL SHEATHING EDGES AT BLOCKING OR FRAMING: MINIMUM 8d NAILS AT 3" O.C.
 - HORIZONTAL SHEATHING EDGES BELOW SECOND FLOOR: MINIMUM 8d NAILS AT 6" O.C.

SHEET KEYNOTES



BUILDING SCIENCE CORPORATION



30 FOREST STREET SOMERVILLE, MA
 T: (978) 589-5100 F: (978) 589-5103
 www.buildingscience.com

CONSULTANT:

PROJECT:
 National Institute of Standards and Technology

NET ZERO ENERGY RESIDENTIAL TEST FACILITY

NIST Campus
 Gaithersburg, MD



U.S. DEPARTMENT OF ENERGY | Energy Efficiency & Renewable Energy

MARK	DATE	DESCRIPTION
ISSUE:	03/31/10	ISSUED FOR CONSTRUCTION

PROJECT NO: NIST NZERTF
 CAD DWG FILE: A-PLOT-PLAN-NZERTF
 DRAWN BY: HW
 CHECKED BY: BP

COPYRIGHT © 2009
 BUILDING SCIENCE CORPORATION
 SHEET TITLE:

SECOND FLOOR KEY PLAN & WALL FRAMING ELEVATIONS
 SCALE AS NOTED

A-110

1 SECOND FLOOR KEY PLAN & WALL FRAMING ELEVATIONS
 SCALE: 1/4" = 1'-0"

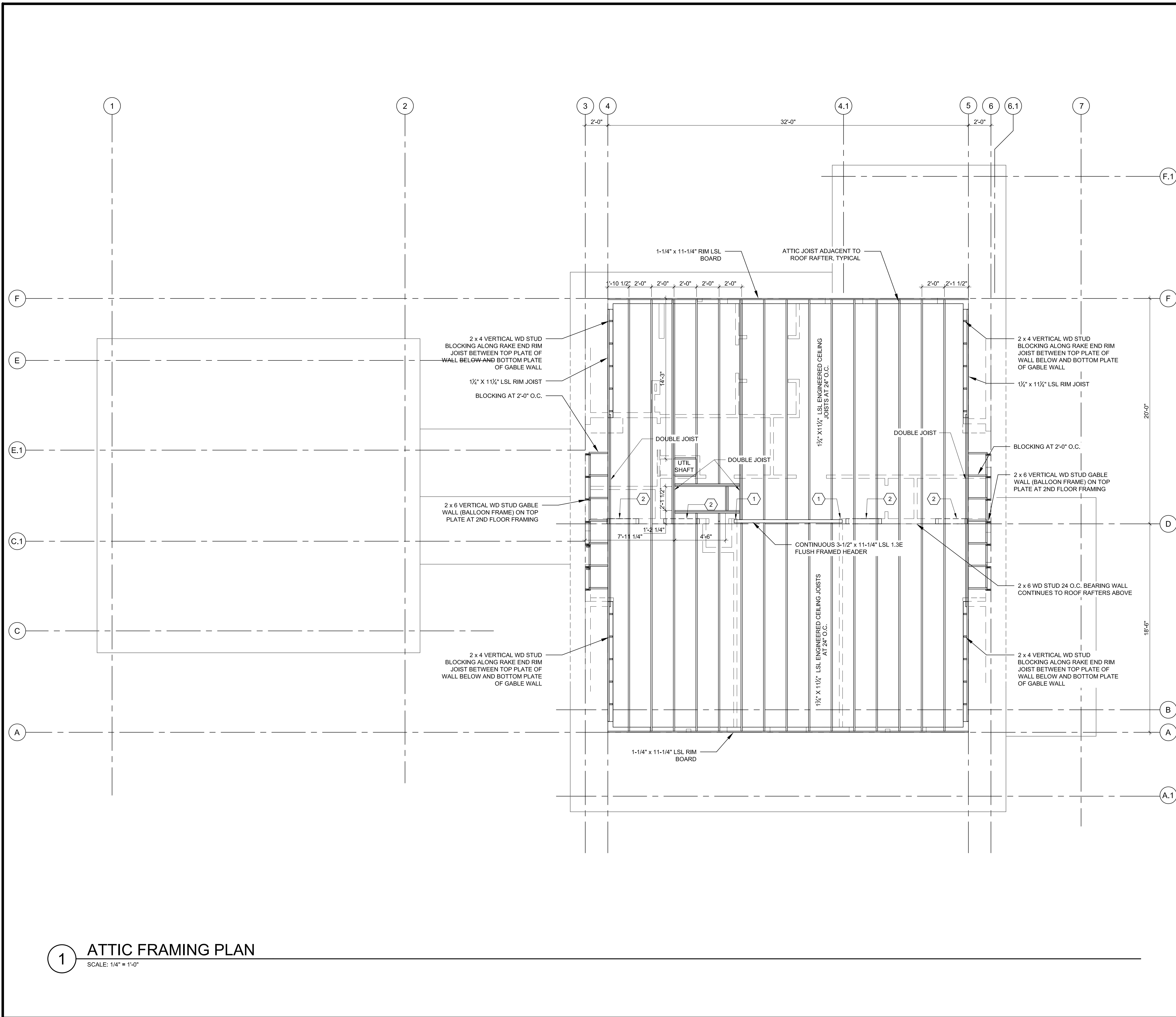

GENERAL SHEET NOTES

- CONTRACTOR TO VERIFY ENGINEERED WOOD PRODUCT (EWP) MEMBER SIZES WITH EWP SUPPLIER.
- EWP CONNECTIONS TO FOLLOW EWP SUPPLIER INSTRUCTIONS.
- LIMIT THE OVERALL ESTIMATED WASTE FACTOR ON THE FRAMING ORDER TO 10% OR LESS.
- GENERAL STRUCTURAL FRAMING CONNECTIONS:
 LSL CEILING JOISTS TO FLOOR HEADERS: USP THD179 ENGINEERED WOOD JOIST HANGER;
 DOUBLE LSL FLOOR HEADER TO TRIMMER: USP HD 410 DOUBLE HANGER.
- STRUCTURAL FRAMING CONNECTIONS FOR CENTER BEARING WALL (TO RESIST ROOF UPLIFT):
 RAFTER TO RIDGE BOARD: USP AC7 ANGLE BRACKET WITH 4 10d NAILS EACH LEG
 RAFTER TO STUD IN ATTIC BEARING WALL: USP LTW12 WITH R 10d NAILS EACH END
 STUD IN ATTIC BEARING WALL TO CEILING JOIST: USP LTW12 WITH 4 10d NAILS EACH END
 CEILING JOIST TO STUD IN SECOND FLOOR BEARING WALL: USP RT10 WITH 4 8d NAILS EACH END (USE USP LTW12 AT CONNECTIONS TO WALL HEADERS)
 STUD TO SOLE PLATE IN SECOND FLOOR BEARING WALL: (2) USP S01 CLIP ANCHORS
 SOLE PLATE TO FLOOR DECK: (2) #8x3" WOOD SCREWS AT 12" O.C.
 ATTIC FLUSH-FRAMED BEAM TO WALL STUDS AT ENDS OF BEAM: USP LTW12 WITH 6 10d NAILS EACH END OF STRAP; PROVIDE CONTINUOUS LOAD PATH DOWN TO BASEMENT BEAM USING SIMILAR SIZED STRAPS AT ALL FRAMING JOINTS.

SHEET KEYNOTES

- FOR LOCATION OF FLUSH FRAMED HEADER AND SUPPORT, SEE A-110, WALL IB2
- FOR SIZE AND LOCATION OF HEADERS IN THE BEARING WALL BELOW SEE A-110, WALL IB2.

BUILDING SCIENCE CORPORATION



30 FOREST STREET SOMERVILLE, MA
 T: (978) 589-5100 F: (978) 589-5103
 www.buildingscience.com

CONSULTANT:

PROJECT:

National Institute of Standards and Technology

NET ZERO ENERGY RESIDENTIAL TEST FACILITY

NIST Campus
 Gaithersburg, MD

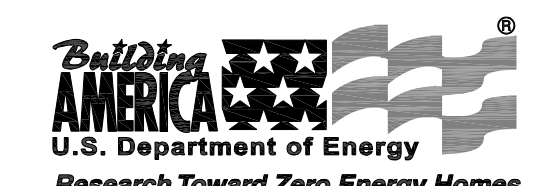

U.S. DEPARTMENT OF ENERGY | Energy Efficiency & Renewable Energy

MARK	DATE	DESCRIPTION
ISSUE:	03/31/10	ISSUED FOR CONSTRUCTION
PROJECT NO:	NIST NZERTF	
CAD DWG FILE:	A-PLOT-PLAN-NZERTF	
DRAWN BY:	CG	
CHECKED BY:	BP	
COPYRIGHT © 2009 BUILDING SCIENCE CORPORATION		
SHEET TITLE:		

ATTIC FRAMING PLAN

SCALE AS NOTED

A-111

1 ATTIC FRAMING PLAN
 SCALE: 1/4" = 1'-0"

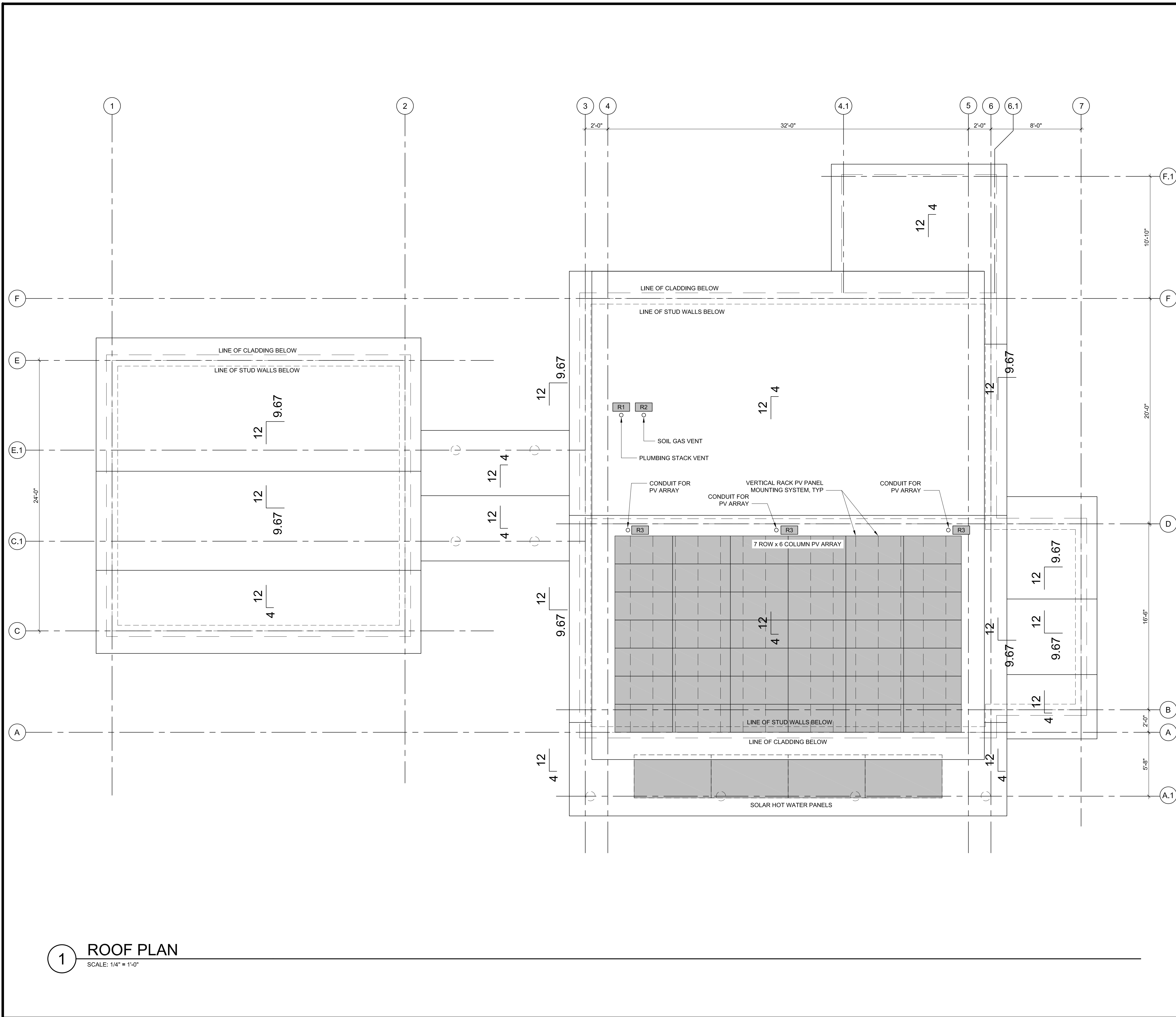

GENERAL SHEET NOTES

1. ROOF PENETRATIONS TO BE LOCATED SO AS TO AVOID POSSIBILITY OF SHADING PHOTOVOLTAIC ARRAY.
2. AT HOUSE, CONTINUOUS FULLY-ADHERED PEEL AND STICK ROOFING MEMBRANE TO BE APPLIED SHINGLE STYLE OVER ENTIRE ROOF INCLUDING OVERHANGS AT EAVES AND RAKES AND OVER PORCHES AND BREEZEWAY.
3. AT HOUSE, CONTINUOUS FULLY-ADHERED PEEL AND STICK ROOFING MEMBRANE TO BE EXTENDED MIN. 12" UP PLYWOOD WALL SHEATHING AT ALL ROOF-WALL INTERSECTIONS EXCEPT WHERE PORCH OR BREEZEWAY ROOF MEETS WALL.
4. AT HOUSE, ADDITIONAL STRIP OF FULLY-ADHERED PEEL AND STICK ROOFING MEMBRANE TO BE APPLIED AT ALL ROOF-WALL INTERSECTIONS EXTENDING MIN. 12" OVER ROOF MEMBRANE AND 12" UP FACE OF WALL INSULATING SHEATHING.
5. AT GARAGE, CONTINUOUS FULLY-ADHERED PEEL AND STICK ROOFING MEMBRANE TO BE APPLIED TO 4:12 SECTION OF ROOF AND AT EAVE OF 9.67:12 SLOPE EXTENDING A MIN. OF 36" FROM THE EXTERIOR WALL TOWARDS THE RIDGE.
6. SEE A-603 FOR PENETRATION SCHEDULE.

SHEET KEYNOTES

PENETRATION KEY

- R1. PLUMBING STACK VENT
- R2. SOIL GAS VENT
- R3. PV CONDUIT

BUILDING SCIENCE CORPORATION



30 FOREST STREET SOMERVILLE, MA
 T: (978) 589-5100 F: (978) 589-5103
 www.buildingscience.com

CONSULTANT:

PROJECT:
National Institute of Standards and Technology

NET ZERO ENERGY RESIDENTIAL TEST FACILITY

NIST Campus
 Gaithersburg, MD



U.S. DEPARTMENT OF ENERGY | Energy Efficiency & Renewable Energy

MARK	DATE	DESCRIPTION
	06/29/10	UPDATED
ISSUE:	03/31/10	ISSUED FOR CONSTRUCTION

PROJECT NO: NIST NZERTF
 CAD DWG FILE: A-PLOT-PLAN-NZERTF
 DRAWN BY: CG
 CHECKED BY: BP
 COPYRIGHT © 2009 BUILDING SCIENCE CORPORATION
 SHEET TITLE:

ROOF PLAN

SCALE AS NOTED

A-113

1 ROOF PLAN
 SCALE: 1/4" = 1'-0"

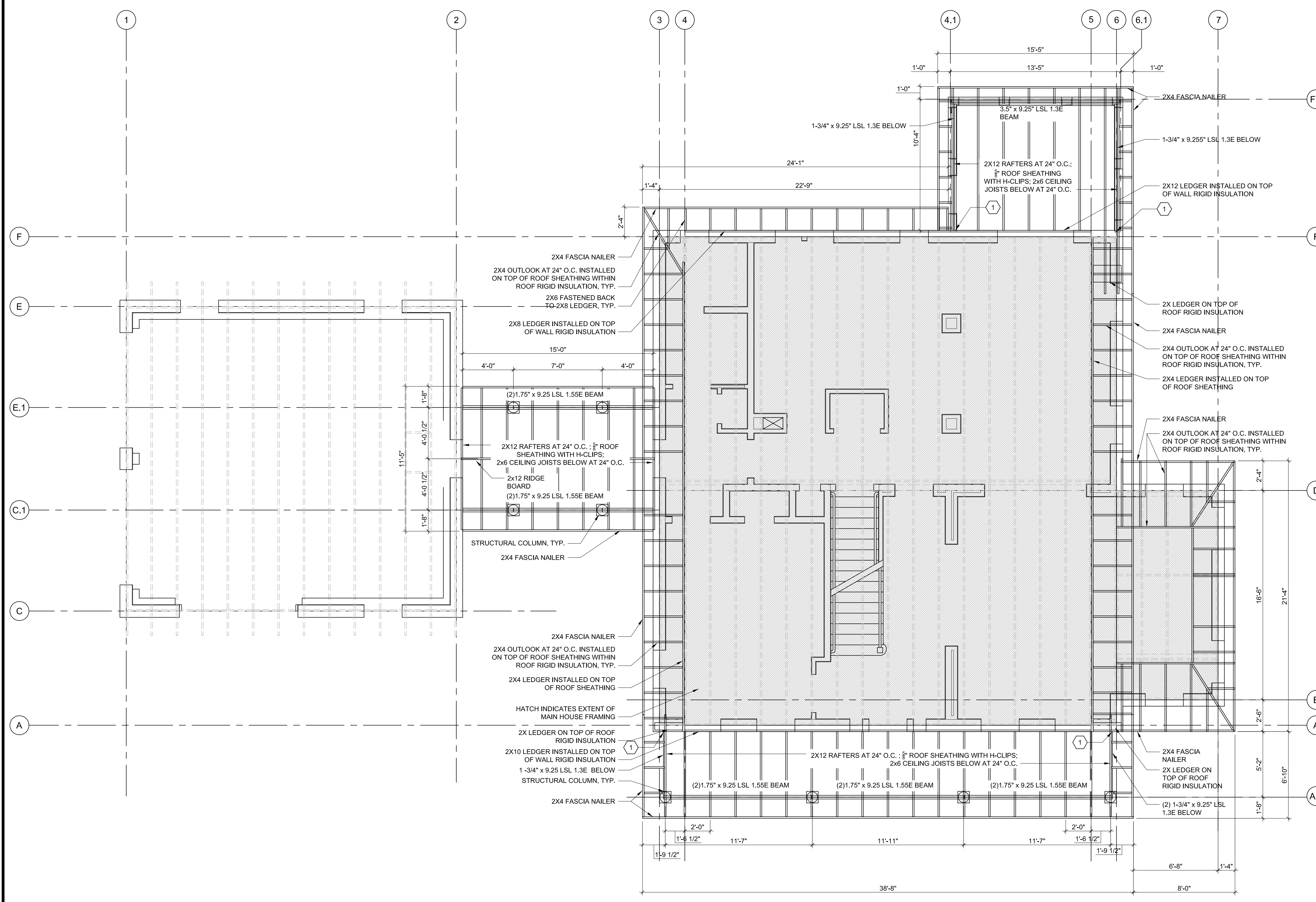

GENERAL SHEET NOTES

- LIMIT THE OVERALL ESTIMATED WASTE FACTOR ON THE FRAMING ORDER TO 10% OR LESS
- STRUCTURAL FRAMING CONNECTIONS FOR 2x4 ROOF OVERHANG OUTRIGGERS (TO RESIST WIND UPLIFT):
(1) #10 x 5" WOOD SCREW THROUGH 2x4 INTO RAFTER RIM BOARD;
(1) #10 x 5" WOOD SCREW THROUGH 2x4 INTO RAFTER, 4" FROM END OF 2x4.
- STRUCTURAL FRAMING CONNECTIONS FOR FRONT PORCH ROOF TO RESIST WIND UPLIFT:
RAFTER LEDGER TO WALL STUDS: (2) 3/8" LAG SCREWS AT 24" O.C. (MINIMUM PENETRATION INTO STUD OF 2");
CEILING JOIST LEDGER TO WALL STUDS: (1) 3/8" LAG SCREW AT 24" O.C. (MINIMUM PENETRATION INTO STUD OF 2");
RAFTER TO LEDGER: USP A37 ANGLE BRACKET;
CEILING JOIST TO LEDGER: 4 16d TOE-NAILS OR USE USP A3 ANGLE BRACKET.
- STRUCTURAL FRAMING CONNECTIONS FOR BREEZEWAY:
USE TIE STRAP AT EACH RAFTER TO TIE RAFTERS TO CEILING JOISTS.
- STRUCTURAL FRAMING CONNECTIONS FOR FRONT PORCH AND BREEZEWAY COLUMNS (TO RESIST WIND UPLIFT):
BEAM TO STRUCTURAL COLUMN AND COLUMN BASE TO SONOTUBE CONNECTION TO FOLLOW COLUMN SUPPLIER'S INSTRUCTIONS; UPLIFT LOAD IS 800 LBS NOMINAL.
- STRUCTURAL FRAMING CONNECTIONS FOR SCREEN PORCH ROOF (TO RESIST WIND UPLIFT AND FOR BRACING):
FASTEN 2x LEDGER AT SLOPE-CUT ENDS OF RAFTERS TO WALL STUDS AT 24" O.C. USING (2) 3/8" LAG SCREWS, TOP AND BOTTOM PENETRATING MINIMUM 2-1/2" INTO STUDS ALONG LENGTH OF LEDGER;
FASTEN PORCH ROOF SHEATHING TO LEDGER USING 8d COMMON NAILS AT 3" O.C.
- 2x FRAMING MEMBERS TO BE FSC-CERTIFIED.

SHEET KEYNOTES

- CONCEALED HANGER SCREWED THROUGH INSULATION TO BLOCKING IN HOUSE WALL

BUILDING SCIENCE CORPORATION



30 FOREST STREET SOMERVILLE, MA
T: (978) 589-5100 F: (978) 589-5103
www.buildingscience.com

CONSULTANT:

PROJECT:
National Institute of Standards and Technology

NET ZERO ENERGY RESIDENTIAL TEST FACILITY

NIST Campus
Gaithersburg, MD



U.S. DEPARTMENT OF ENERGY | Energy Efficiency & Renewable Energy

MARK	DATE	DESCRIPTION
ISSUE:	03/31/10	ISSUED FOR CONSTRUCTION

PROJECT NO:	NIST NZERTF
CAD DWG FILE:	A-PLOT-PLAN-NZERTF
DRAWN BY:	CG
CHECKED BY:	BP

COPYRIGHT © 2009
BUILDING SCIENCE CORPORATION
SHEET TITLE:

LOWER ROOF OVERHANG FRAMING PLAN

SCALE AS NOTED

A-114

1 LOWER ROOF OVERHANG FRAMING PLAN
SCALE: 1/4" = 1'-0"

GENERAL SHEET NOTES

- LIMIT THE OVERALL ESTIMATED WASTE FACTOR ON THE FRAMING ORDER TO 10% OR LESS
- STRUCTURAL FRAMING CONNECTIONS FOR 2x4 ROOF OVERHANG OUTRIGGERS (TO RESIST WIND UPLIFT):
 - (1) #10 x 5" WOOD SCREW THROUGH 2x4 INTO RAFTER RIM BOARD;
 - (1) #10 x 5" WOOD SCREW THROUGH 2x4 INTO RAFTER, 4" FROM END OF 2x4.
- 2x FRAMING MEMBERS TO BE FSC-CERTIFIED.

BUILDING SCIENCE CORPORATION



30 FOREST STREET SOMERVILLE, MA
T: (978) 589-5100 F: (978) 589-5103
www.buildingscience.com

CONSULTANT:

SHEET KEYNOTES

PROJECT:

National Institute of Standards and Technology

**NET ZERO ENERGY
RESIDENTIAL TEST
FACILITY**

NIST Campus
Gaithersburg, MD



U.S. DEPARTMENT OF ENERGY | Energy Efficiency & Renewable Energy

MARK	DATE	DESCRIPTION
ISSUE:	03/31/10	ISSUED FOR CONSTRUCTION

PROJECT NO: NIST NZERTF
CAD DWG FILE: A-PLOT-PLAN-NZERTF
DRAWN BY: CG
CHECKED BY: BP

COPYRIGHT © 2009
BUILDING SCIENCE CORPORATION
SHEET TITLE:

UPPER ROOF OVERHANG FRAMING PLAN

SCALE AS NOTED

A-115

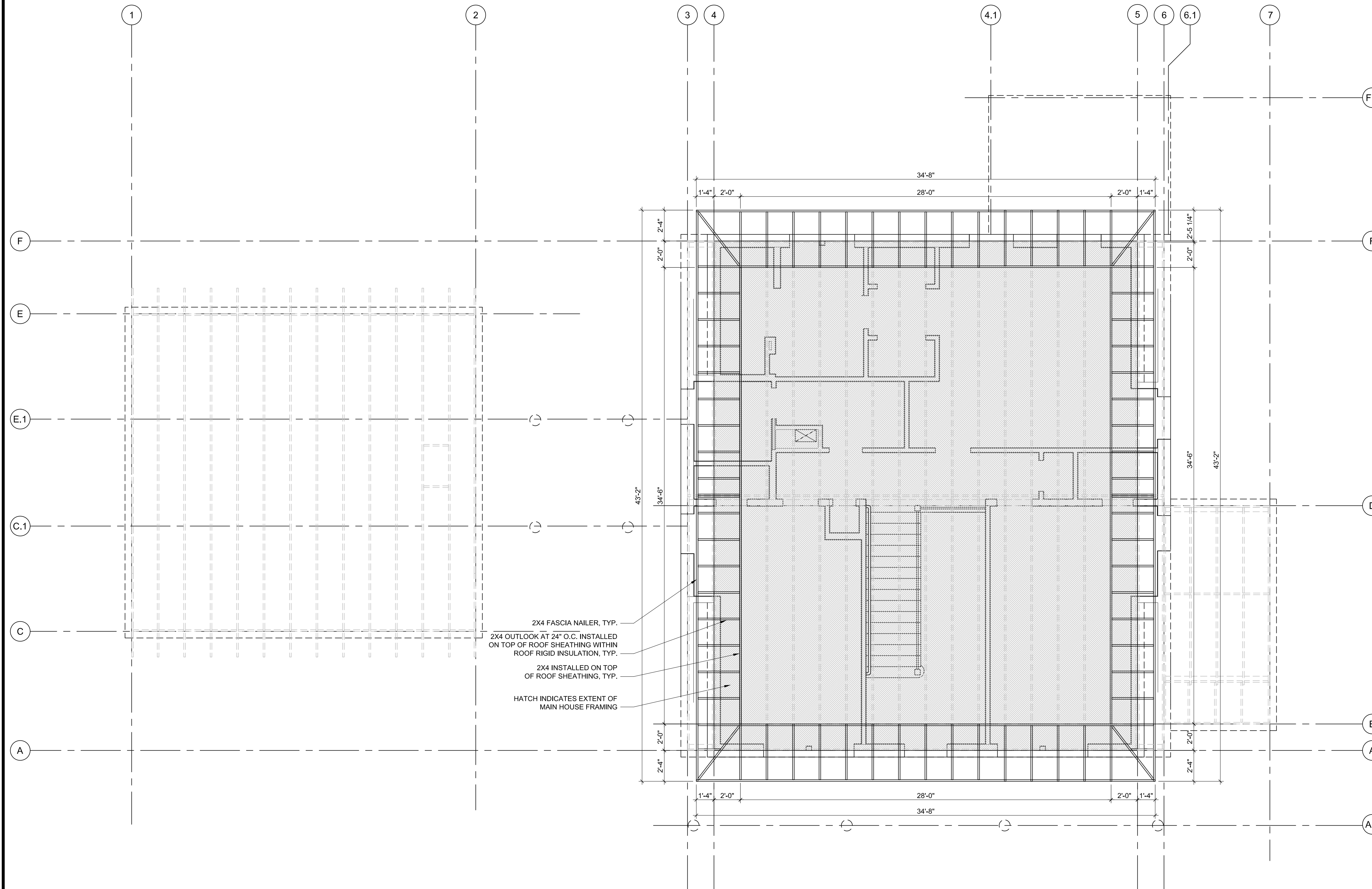

1 UPPER ROOF OVERHANG FRAMING PLAN

SCALE: 1/4" = 1'-0"

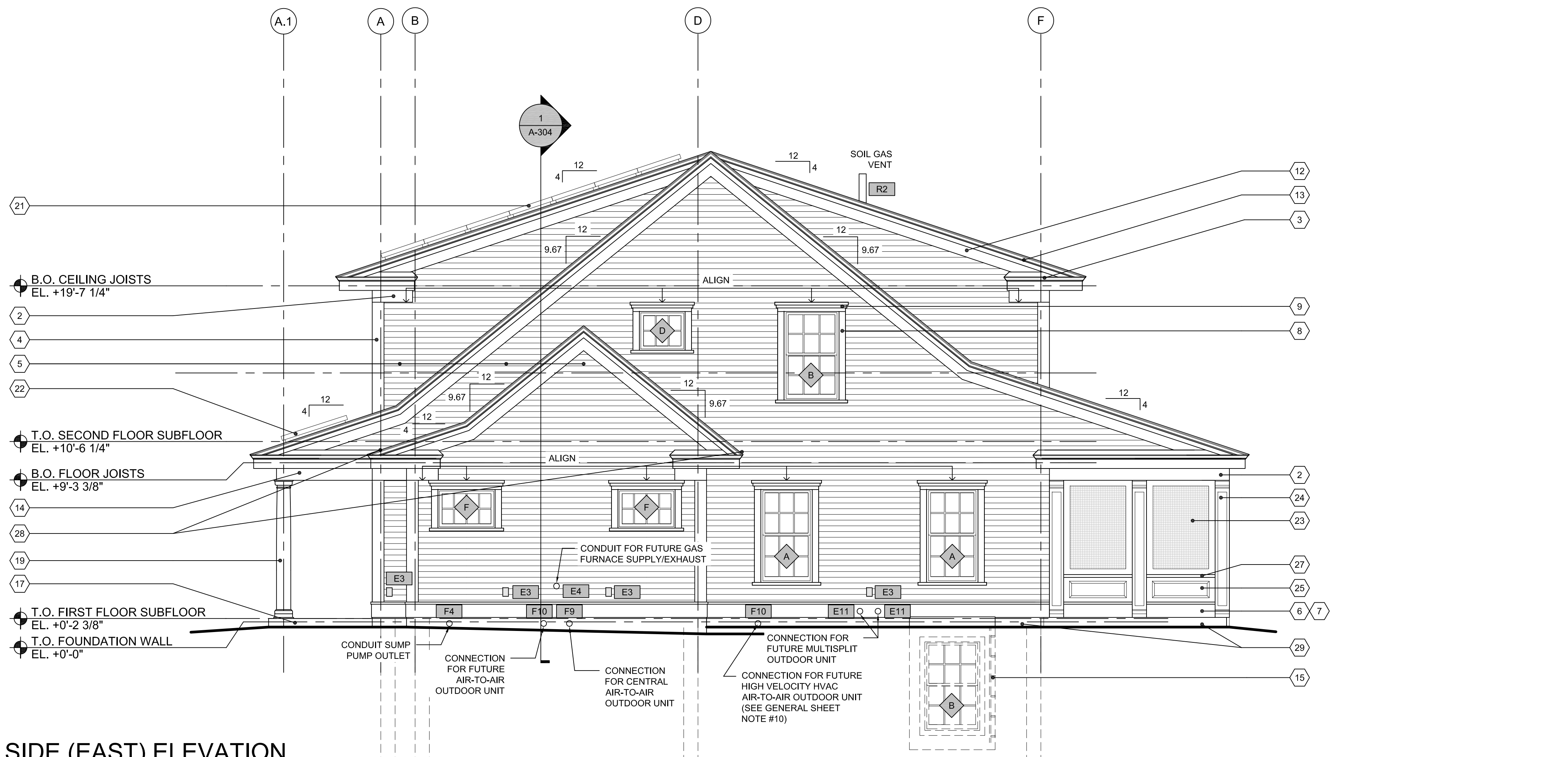

2 RIGHT SIDE (EAST) ELEVATION
SCALE: 1/4" = 1'-0"

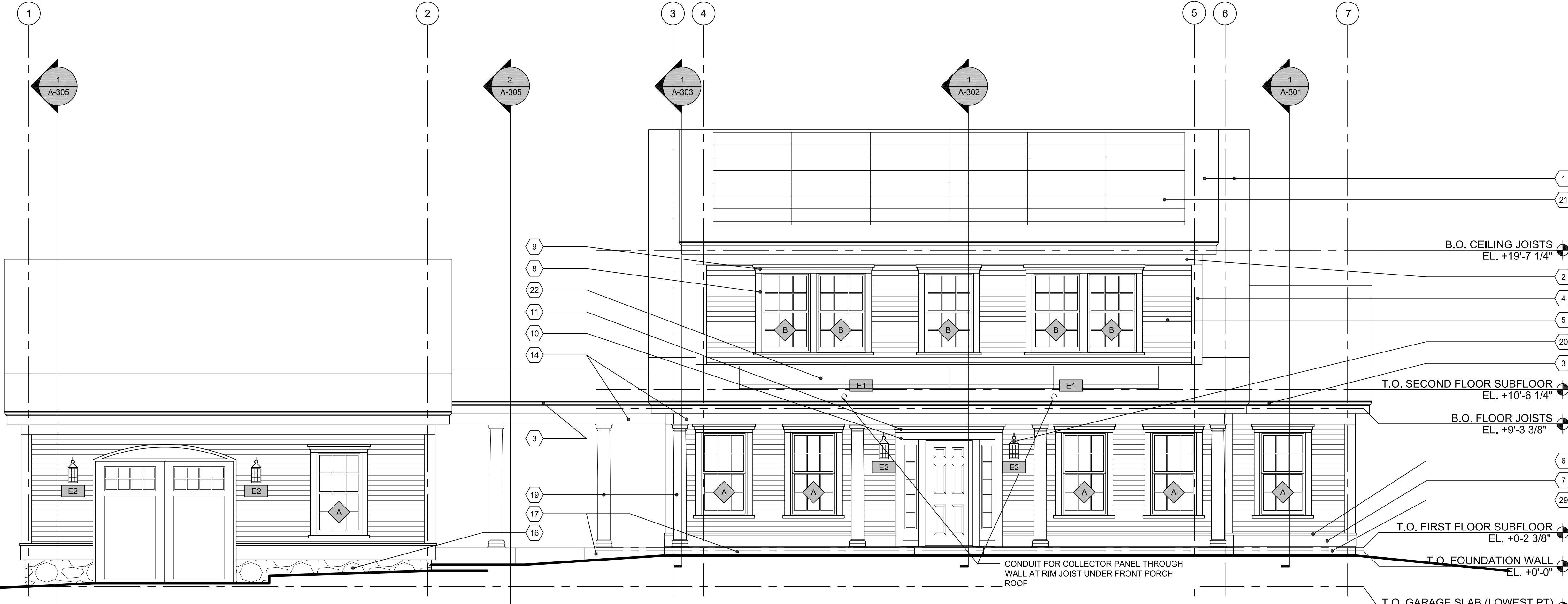

1 FRONT (SOUTH) ELEVATION
SCALE: 1/4" = 1'-0"

GENERAL SHEET NOTES

- FIRST FLOOR SOFFITS AND SECOND FLOOR SOFFITS TO ALIGN AROUND PERIMETER OF HOUSE.
- SEE A-601 FOR WINDOW SCHEDULE.
- SEE A-603 FOR PENETRATION SCHEDULE.
- SIDING TO BE PAINTED P-12.
- ALL TRIM AND SOFFITS TO BE PAINTED P-13.
- ALL DOORS TO BE PAINTED P-14.
- CEILINGS OF PORCHES AND BREEZEWAY TO BE PAINTED P-15.
- FRONT PORCH AND BREEZEWAY COLUMNS TO BE PAINTED P-13.
- EL. +0'-0" IN THE ARCHITECTURAL DRAWINGS CORRESPONDS TO 461.30' IN THE SITE/CIVIL DRAWINGS.
- IF THE HIGH VELOCITY HVAC OPTION IS NOT AWARDED, THE PENETRATION FOR THE CONNECTION WILL NOT BE PROVIDED.

SHEET KEYNOTES

- ASPHALT ROOF SHINGLES
- 1" x 8" FRIEZE BOARD TRIM MOULDING
- 5/8" x 8" TRIM WITH 3" CROWN MOULDING
- 1" x 8 1/2" TRIM
- FIBER CEMENT SIDING, 4" EXPOSURE
- 2 x 2 TRIM
- 5/8" x 10 TRIM
- 1" x 4 1/2" WINDOW TRIM
- BUILT-UP WINDOW CROWN
- 1" x 6" DOOR TRIM
- BUILT-UP DOOR CROWN
- 5/4 x 8 TRIM
- 5/8" x 6 RAKE EDGE TRIM WITH 3" CROWN MOULDING
- 1" x 8 3/8" BEAM TRIM
- EGRESS WINDOW WELL AND LADDER
- STONE VENEER AT GARAGE FOUNDATION WALL
- CONCRETE DECK
- CONCRETE WALL WITH STONE VENEER EDGES
- LOAD-BEARING COLUMN
- EXTERIOR LANTERN
- PV ARRAY
- SOLAR COLLECTOR (HOT WATER SYSTEM)
- SCREEN PANEL
- PREFABRICATED PILASTER
- FIBER CEMENT PANEL
- FIBER CEMENT TRIM
- 2" SILL
- KICK-OUT FLASHING
- ALUMINUM COIL STOCK COVERING

WINDOW KEY

- A. 3'-0" x 5'-5" DH
- B. 3'-2 1/2" x 5'-2" DH
- C. 2'-1" x 3'-7" DH
- D. 2'-8" x 2'-3" AWN
- E. 2'-3" x 4'-0" DH
- F. 3'-4" x 2'-3" AWN
- G. 3'-4" x 2'-7" AWN

PENETRATION KEY

- E1. COLLECTOR PANEL CONDUIT
- E2. EXTERIOR LANTERN
- E3. WEATHER PROTECTED OUTLET
- E4. CONDUIT FOR FUTURE GAS FURNACE
- E5. DRYER VENT
- E6. RANGE HOOD VENT
- E7. HRV EXHAUST
- E8. HRV INLET
- E9. INSTRUMENTATION CONDUIT
- E10. CONDUIT FOR FUTURE GAS WATER HEATER
- E11. FUTURE MULTI-SPLIT OUTDOOR UNIT CONNECTION
- E12. HOSE BIBB
- F4. SUMP PUMP OUTLET
- F9. AIR-TO-AIR OUTDOOR UNIT CONNECTION
- F10. FUTURE AIR-TO-AIR OUTDOOR UNIT CONNECTION
- R1. PLUMBING STACK VENT
- R2. SOIL GAS VENT

BUILDING SCIENCE CORPORATION



30 FOREST STREET SOMERVILLE, MA
T: (978) 589-5100 F: (978) 589-5103
www.buildingscience.com

CONSULTANT:

PROJECT:

National Institute of Standards and Technology
NET ZERO ENERGY RESIDENTIAL TEST FACILITY
NIST Campus Gaithersburg, MD



U.S. DEPARTMENT OF ENERGY | Energy Efficiency & Renewable Energy

MARK	DATE	DESCRIPTION
	08/03/10	UPDATED
	07/27/10	UPDATED
	06/29/10	UPDATED
ISSUE:	03/31/10	ISSUED FOR CONSTRUCTION

PROJECT NO: NIST NZERTF
CAD DWG FILE: A-PLOT-ELEV-NZERTF
DRAWN BY: CG
CHECKED BY: BP
COPYRIGHT © 2009 BUILDING SCIENCE CORPORATION

EXTERIOR ELEVATIONS

SCALE AS NOTED

A-201