

UNITED STATES DEPARTMENT OF THE INTERIOR

GEOLOGICAL SURVEY



**An Evaluation of Installation Methods  
For STS-1 Seismometers**

By

L. Gary Holcomb

Charles R. Hutt

Open File Report 92-302

This report is preliminary and has not been reviewed for  
Conformity with U.S. Geological Survey editorial standards.  
Any use of trade names is for descriptive purposes only and  
Does not imply endorsement by the U.S. Geological Survey.

Albuquerque, New Mexico

1992

# 1 INTRODUCTION

This report documents the results of a series of experiments conducted by the authors at the Albuquerque Seismological Laboratory (ASL) during the spring and summer of 1991; the object of these experiments was to obtain and document quantitative performance comparisons of three methods of installing STS-1 seismometers.

Historically, ASL has installed STS-1 sensors by cementing their thick glass base plates to the concrete floor of the vault (see Peterson and Tilgner, 1985, p 44 and Figure 31, p 51 for the details of this installation technique). This installation technique proved to be fairly satisfactory for the China Digital Seismic Network and for several sets of STS-1 sensors installed in other locations since that time. However, the cementing operation is rather labor intensive and the concrete requires a lengthy (about 1 week ) curing time during which the sensor installed on it is noisy. In addition it is difficult to assure that all air bubbles have been removed from the interface between the cement and the glass base plate. If air bubbles are present beneath the plate, horizontal sensors can be unacceptably noisy. Moving a sensor installed in this manner requires the purchase of a new glass base plate because the old plate normally can not be removed without breakage.

Therefore, this study was undertaken with the aim of developing an improved method of installing STS-1's. The goals were to develop a method which requires less field site labor during the installation and assures a higher quality installation when finished. In addition, the improved installation technique should promote portability.

Two alternate installation techniques were evaluated in this study. One method replaces the cement between the base plate and the vault floor with sand. This method has been used in the French Geoscope program and in several IRIS/IDA installations made by the University of California at San Diego (UCSD) and possibly others. It is easily implemented in the field and is quite cheap. The other method utilizes a so called warpleless housing designed by E. Wielandt and implemented at ASL. This housing is quite similar to the case design of the STS-2 sensor system. It is designed to minimize the effects of atmospheric pressure variations on the sealed housing.

## 2 DATA PROCESSING

The quantitative results of the various test configurations are presented in terms of power spectral density (PSD) plots. Briefly, the PSD data was computed as follows. The time series from which the PSD plots were generated were originally sampled at 1 sample per second. They were then lowpass filtered, decimated by a factor of 2, and split up into 2048 point segments with a 50% overlap between segments. All of the data was fast Fourier transformed (FFT) and the power spectra for each segment was calculated. The power spectrum of each segment was summed between 30 and 100 seconds and only the 10% of the segments for which this sum were smallest were included in the final segment averaged estimate for the system PSD. Thus, the quietest 10% of the original segments were averaged to yield the final PSD estimate. The system noise estimates were derived with the direct method (see Holcomb, 1989). This method is capable of evaluating the individual noise levels of two sensors with a common input signal even if the noise levels are unique. It calculates these noise levels directly without invoking the coherence function as an intermediate step.

All of the PSD figures in this report contain three sets of data. The heavy thick curve labeled LNM is Peterson's low noise model for a typical quiet continental site. This low noise model was derived from data recorded at several sites around the world (see Peterson, 1980). This data does not change from figure to figure; it is included to provide a reference against which the sensor system performance can be compared between the different test configurations. The thin line plot labeled P11 in the figure headers is the estimate of the total power out of the sensor system under the conditions indicated in the figure captions. The thin line curve with superimposed small circles labeled N1 in the figure headers is the estimate of the system noise for the sensor system.

The sensor system is assumed to be composed of two parts; they are the STS-1 seismometer plus the installation hardware. In this report, the seismometers themselves will be assumed to be equally noisy and any differences in calculated noise estimates between installation methods will be attributed to differences in the installations themselves.

The qualitative results are presented in the time domain figures. Each figure contains 24 hours of data at an arbitrary gain (the gain in all of the figures is the same however). Prior to plotting, the data has been filtered with a 15 second low pass filter to eliminate the 6 second microseisms and enhance the appearance of long period ground motion.

### 3 GLASS PLATE WITH SEALED PLASTIC BELL JAR INSTALLED ON SAND

This installation technique replaces the rigid airtight concrete interface between the glass base plate and the vault floor with a layer of specially selected sand. This sand is called crystal sand and was supplied by Don Miller of UCSD. First the vault floor was cleaned of all loose material and allowed to dry. Then a layer of sand was spread on the floor and leveled to cover an area equal to the area of the base plate plus approximately 3 inches on each side. The base plate was then placed on the sand and gently worked into the sand approximately half an inch deep. The sensor was installed on the glass plate under a sealed plastic bell jar.

Both the sand and cement installed systems were allowed to operate undisturbed for over 10 days starting at 1991,173,18:35 to allow the newly installed sand system to settle down and reach quiet operating conditions.

Figures 3.1 and 3.2 contain the time domain record for day 178 obtained from the STS-1 horizontal sensor installed on a glass base plate resting on sand and the time domain record for the same day obtained from the STS-1 horizontal sensor installed on a cemented glass base plate respectively. Both bell jars were sealed during this time period. This record is typical of the data obtained during the entire 10 day recording period. Inspection of the time traces in the figures indicates that the sensor installed on sand was very noisy at long periods as compared with the cemented STS-1. This is true at all times during day 178 but the sand installed system is especially noisy while the wind was blowing during the last 4 hours or so of the day.

Figure 3.3 presents estimates of the total power spectral density at the output of the sand installed STS-1 and estimates of the system noise in this installation. Figure 3.4 contains the same information for the cemented installation. The total power out of the sand installed STS-1 (P11, the thin solid line) is considerably greater than the total power out of the cemented sensor above approximately 20 seconds. At 100 seconds the sand STS-1 output power is almost 10 times that for the cemented unit and at 1000 seconds it is nearly 1000 times as great. The system noise estimate for the cemented sensor (N1, the thin solid line with small circles) is a factor of about 70 lower than that for the sand installed instrument at 100 seconds. Above 100 seconds, the noise estimate for the sand installed instrument is nearly equal to the total power out of the instrument. For the cemented instrument, the noise estimate above 100 seconds as shown in Figure 3.4 is biased upward because the total power out of the sand instrument is so high in that part of the spectrum. It is physically impossible for the noise power out of the instrument (N1) to be greater than the total power out of the instrument (P11) as is shown in Figure 3.4. Above 100 seconds, the system noise for the cemented instrument is considerably lower than is shown in the figure.

This data obtained in this experiment demonstrates that installing a horizontal STS-1 on sand under a sealed bell jar creates excessive noise at long periods.

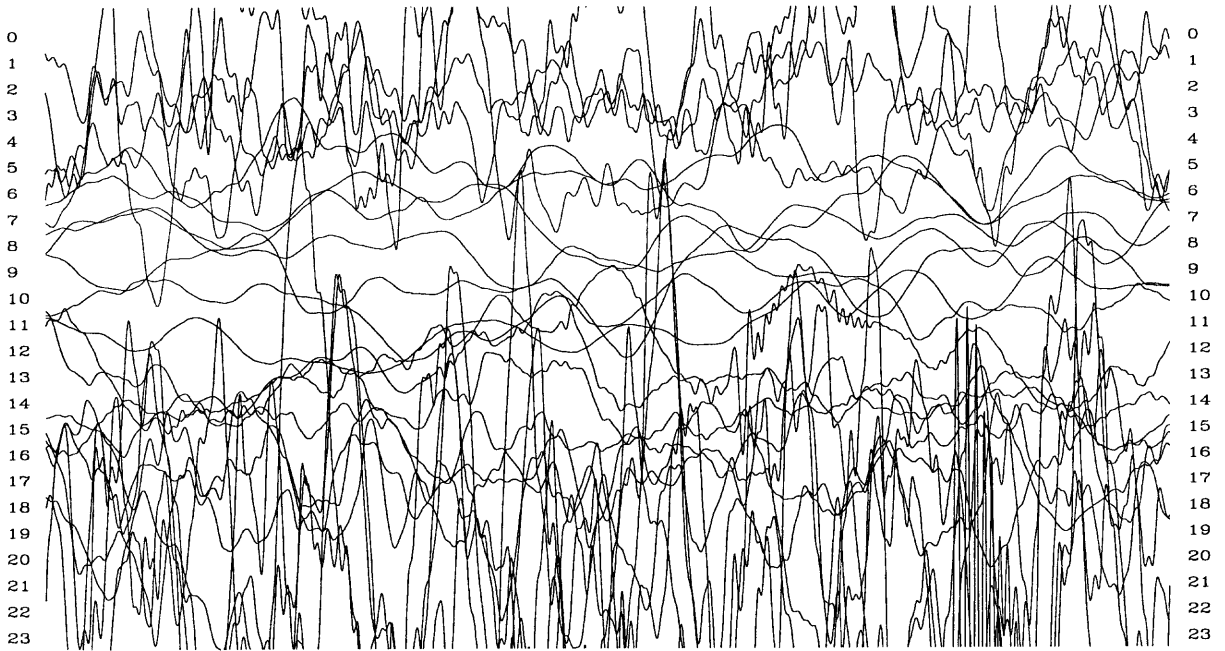

Figure 3.1 Time record for day 178 from the STS-1 horizontal sensor installed on a glass plate resting on sand under a sealed plastic bell jar. The last four hours of the record contain data during a windy time period.

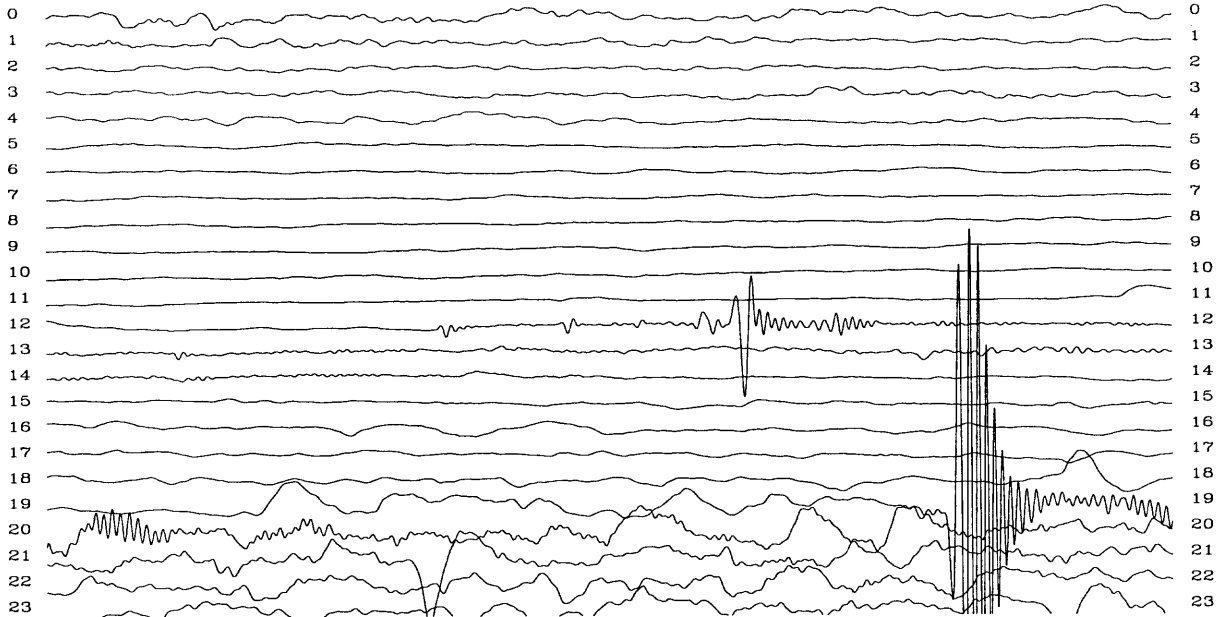

Figure 3.2 Time record for day 178 from the STS-1 horizontal sensor installed on a glass plate cemented to the floor under a sealed glass bell jar. The last four hours of the record contain data during a windy time period

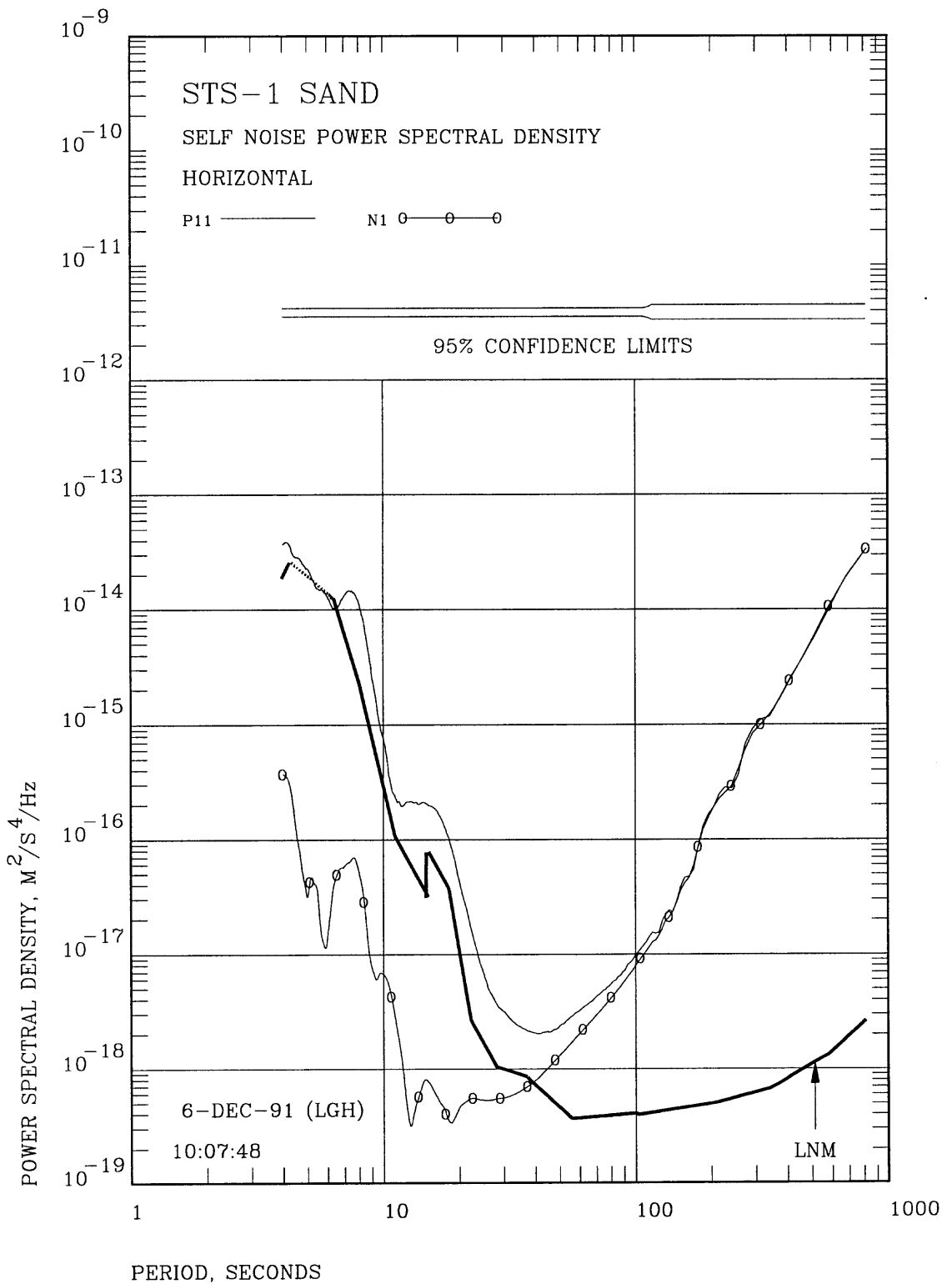

Figure 3.3 Estimated noise level of a STS-1 horizontal sensor installed on a glass plate resting on sand under a sealed plastic bell jar.

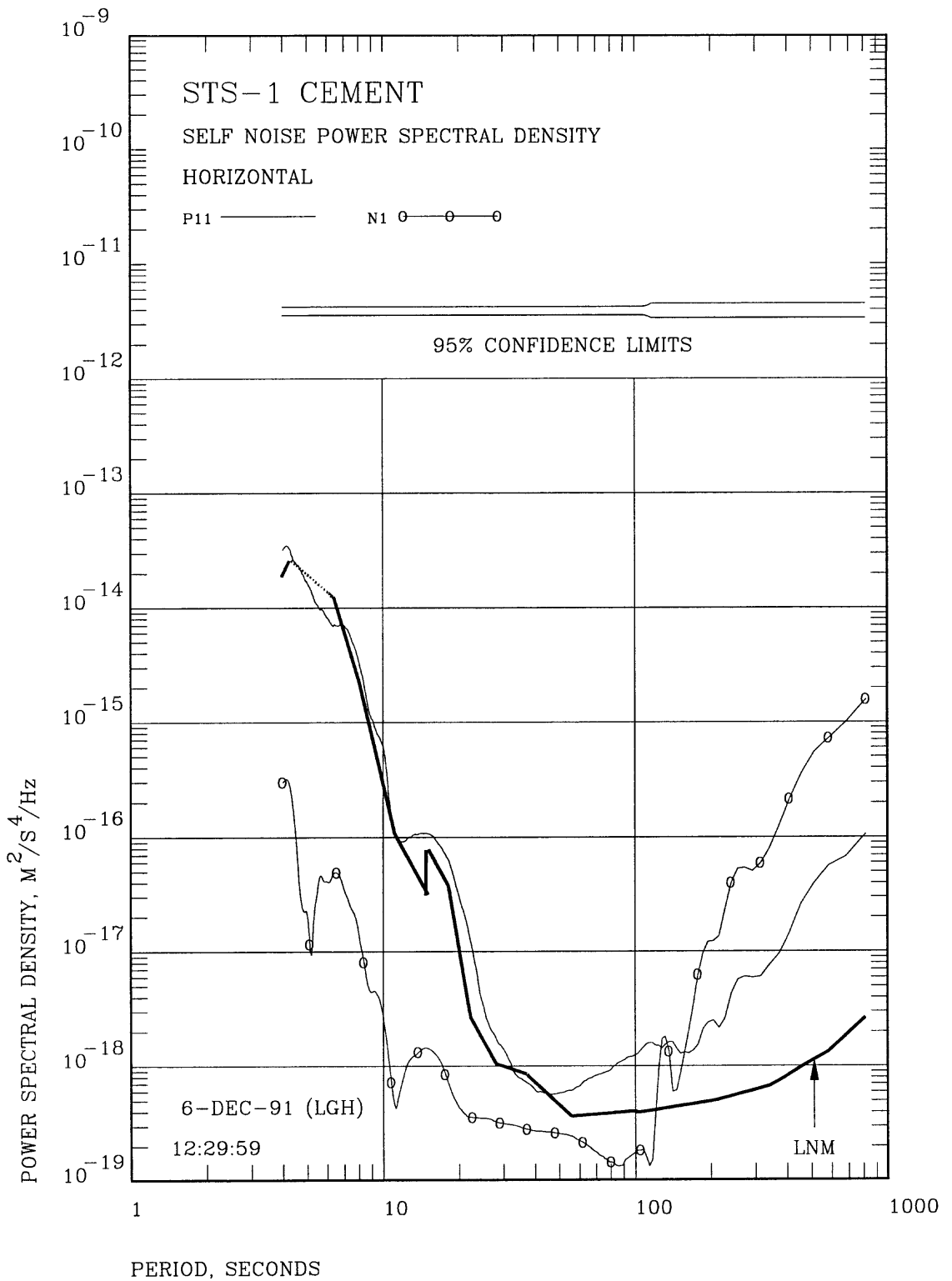

Figure 3.4 Estimated noise level of a STS-1 horizontal sensor installed on a glass plate cemented to the floor under a sealed glass bell jar. (See text for an explanation of  $N_1$  greater than  $P_{11}$  from 100 to 1000 seconds period)

## 4 GLASS PLATE WITH VENTED PLASTIC BELL JAR INSTALLED ON SAND

In this section, the technique used to install the seismometer is the same as that in Section 3 except that the plastic bell jar was left vented (open to the atmosphere) while the data was recorded. Experience in the past at ASL with the heavy prestressed half inch thick steel bottomed High Gain Long Period (HGLP) environmental isolation tanks indicates that even very heavily constructed containers bend under external atmospheric pressure variations during windy time periods. This bending generates incredible levels of tilt noise in long period seismic sensors. A glass plate installed on a bed of sand is subject to atmospheric pressure variations over its entire lower surface because the sand is porous. A sealed bell jar installed on top of the plate creates a bending moment on the glass plate because the top of the plate is isolated from atmospheric pressure variations. Venting the bell jar eliminates the bending moment by equalizing the pressure variations on both sides of the glass plate as the data contained in this section will demonstrate.

The only change in the configuration of the two systems between that in Section 3 and this section was to vent the sand installed system by opening the evacuation valve. Otherwise, the two systems were not disturbed. Therefore, a minimum of settling time should be expected. The two systems were allowed to operate undisturbed for over 6 and a half days starting at 1991,189,21:30.

Figure 4.1 contains the time record from day 192 for the horizontal STS-1 installed on a glass plate resting on sand under a vented plastic bell jar. Comparing Figure 4.1 with the record for the sealed plastic bell data contained in Figure 3.1 shows that the improvement in noise levels created by venting the bell jar is very dramatic. The vented sand time domain data is obviously quieter than was the sealed data. However, there are several obviously non seismic events, which are evident in the time domain data. For instance, possible settling burps are visible at approximately 09:50, 10:40, 13:45, and 14:05. These events may also be due to activity in the vault such as doors opening and closing because they occur during the daytime. Otherwise, there is a large degree of visible coherence between the vented sand and the cemented instrument time traces shown in the figure below.

Figure 4.2 contains the time record for day 192 for the horizontal STS-1 installed on a glass plate cemented to the vault floor. Comparing this figure with the data for the vented sand installation in Figure 4.1 indicates that the vented sand data is nearly as quiet as the cemented installation data at times. Although not all of the data is shown, there was some settling noise in the vented sand installation early in the test period. However, by day 192, the sand data compares very favorably with the cemented data. In particular note the similarity of the data during hours 21, 22, and 23 for day 192. It is the authors' contention that what little settling noise is present in the data will die out with time.

Figure 4.3 contains estimates of the total power spectral density out of the STS-1 installed on sand under a vented bell jar and estimates of the system noise level under these conditions. Note the extensive decrease in both of these power spectral density estimates as compared with the sealed bell jar situation shown in Figure 3.3.



Figure 4.4 contains estimates of the total power spectral density out of the STS-1 installed on a glass plate cemented to the floor for the same time period as for the vented sand results in Figure 4.3. The vented sand installation data of Figure 4.3 compares quite favorably with the sealed cemented data shown in Figure 4.4. The total power out of the vented sand STS-1 is slightly higher than for the cemented instrument and the system noise estimates are also slightly higher but the overall performance of the vented sand installation is quite acceptable.

The results of Sections 3 and 4 dramatically illustrate the potential pitfalls of installing horizontal long period instruments in sealed containers. Atmospheric pressure variations bend the bottom of any container and this bending translates into tilt generated long period noise. Venting the container eliminates the majority of this noise. At ASL, this noise source was first identified many years ago in the old HGLP systems and their impressively massive environmental isolation tanks. As rugged as the HGLP tanks were, the bottoms still flexed if the tanks were sealed, whereas venting them significantly reduced the long period noise levels on horizontal instruments.

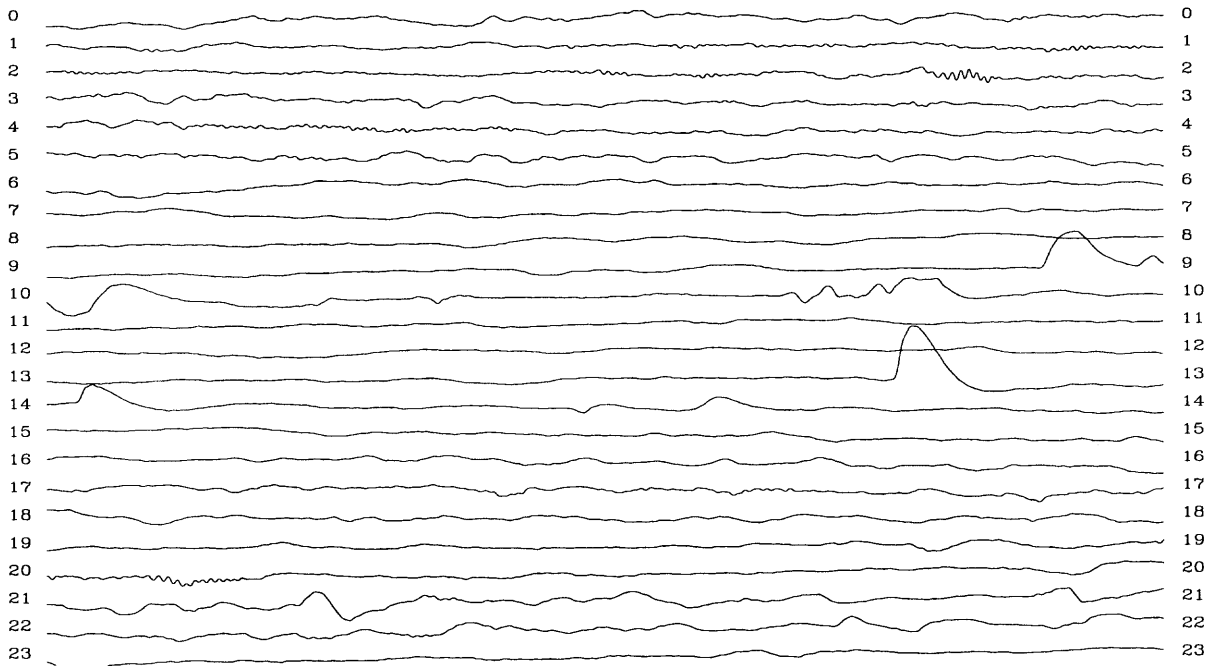

Figure 4.1 Time record for day 192 from the STS-1 horizontal sensor installed on a glass plate resting on sand under a vented plastic bell jar.

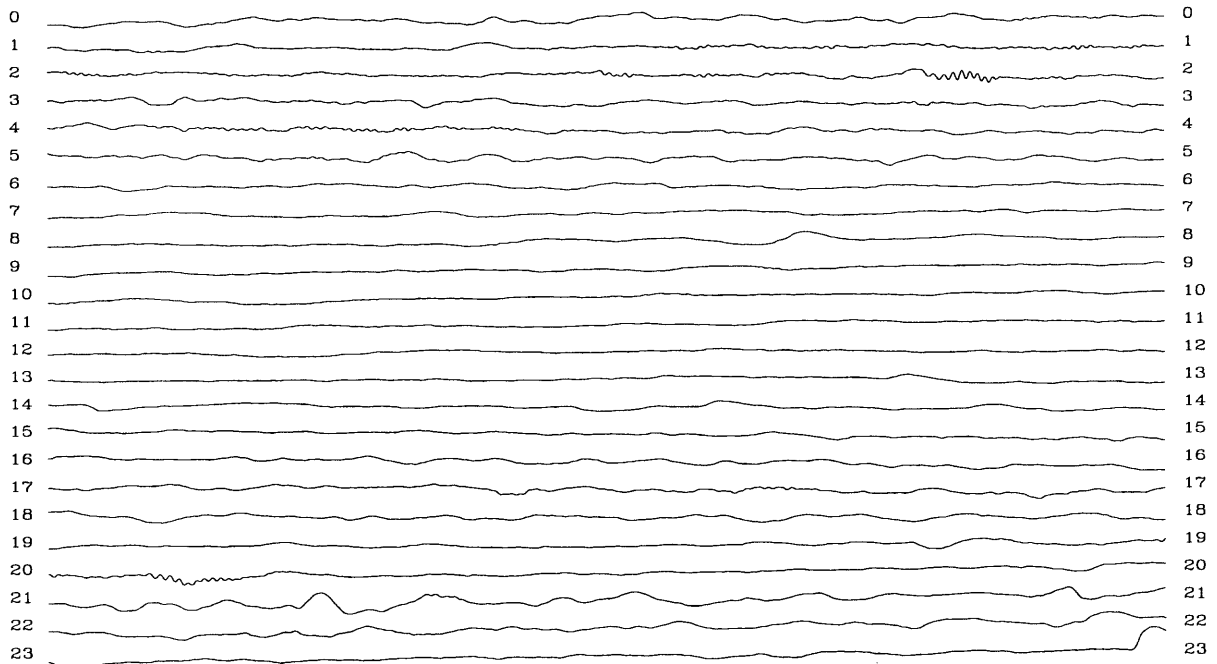

Figure 4.2 Time record for day 192 from the STS-1 horizontal sensor installed on a glass plate cemented to the floor under a sealed glass bell jar.

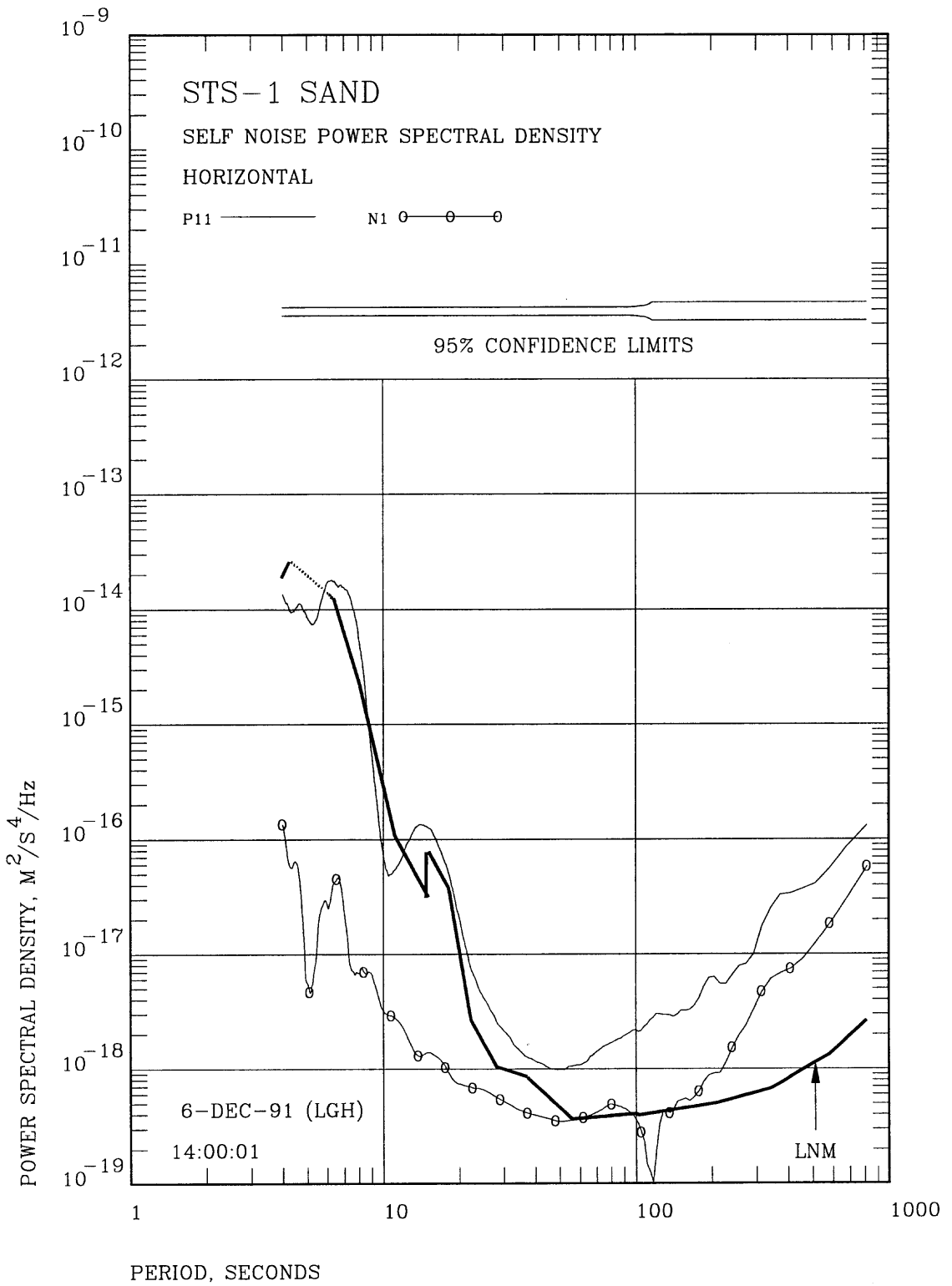

Figure 4.3 Estimated noise level of a STS-1 horizontal sensor installed on a glass plate resting on sand under a vented plastic bell jar.

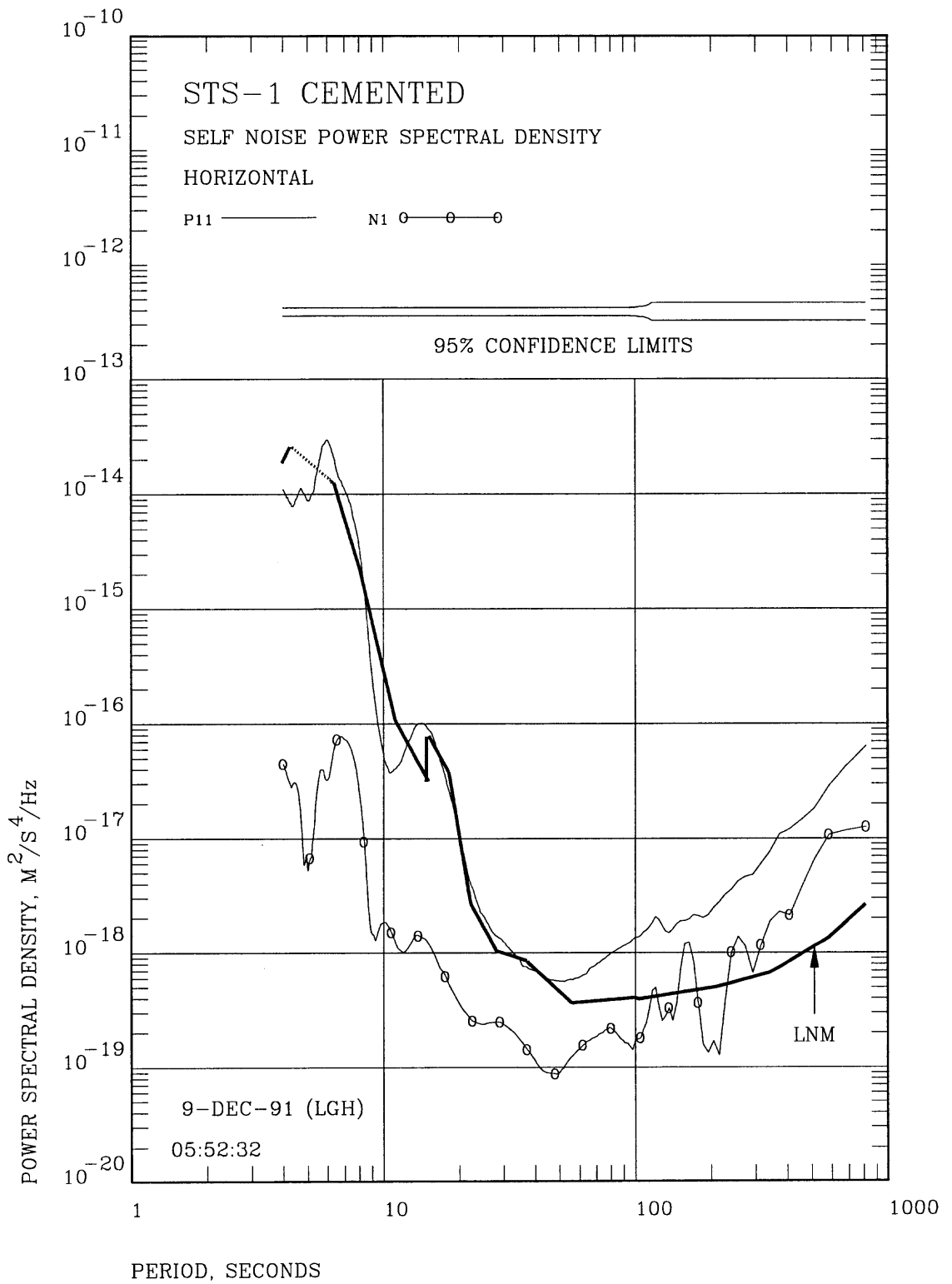

Figure 4.4 Estimated noise level of a STS-1 horizontal sensor installed on a glass plate cemented to the floor under a sealed glass bell jar.

## 5 ALUMINUM WARPLESS BASE PLATE WITH A SEALED PLASTIC BELL JAR

The warpless housing design was obtained from E. Wielandt , Stuttgart University, and was refined and implemented by Bob Hutt at ASL. Detailed engineering drawings (these drawings courtesy of Bob Young, ASL) of the assembly and its major individual parts are presented in this report as appendix A. Basically the warpless housing is a mechanical scheme which replaces the thick glass base plate of a conventional STS-1 installation with a thick metal plate (referred to as "PLATE 2" in the DETAIL-2 drawing in the appendix). The construction of the assembly equalizes the air pressure on both sides of the plate by creating an equal pressure chamber on the side of the plate opposite the bell jar. Thus, the bell jar can be sealed without creating any significant pressure generated bending moment on the metal base plate. The details of the equal pressure chamber are visible in the ASSEMBLY CROSS SECTION drawing in the appendix.

A warpless housing with an aluminum base plate (referred to as "PLATE 2" in the drawing on page A-1) was fabricated and fitted with a plastic bell jar. Earlier tests conducted at ASL had established that STS-1 performance under a plastic bell jar was equivalent to their performance under a glass bell jar. Since plastic bell jars are cheaper and much less susceptible to breakage, they are preferred over the older glass versions. A STS-1 horizontal sensor was installed in the warpless housing in the ASL vault and allowed to operate in conjunction with the cemented system for approximately 7 days beginning at 1991,155,23:00:00.

Figure 5.1 contains a time record for day 161 from the STS-1 horizontal installed in a warpless housing under a sealed plastic bell jar. Comparing this figure with Figure 5.2, which contains a time record for the same day from the STS-1 horizontal installed on a cemented glass base plate, reveals that the warpless sealed plastic bell jar installation is noisier at long periods particularly during hours 20 through 23. Both sensors became noisier during this time period; this increase in noise in both sensors is probably generated by wind.

Figure 5.3 contains estimates of the noise levels for the STS-1 installed in the warpless housing. The segments used to calculate these noise estimates were selected by the aluminum base plate warpless housing output data. Figure 5.4 contains estimates of the noise levels for the STS-1 installed on a glass plate cemented to the vault floor. The segments used to calculate these noise estimates were selected by the data from the STS-1 installed in the aluminum base plate warpless housing. Therefore, the data contained in Figures 5.3 and 5.4 favors the warpless installation. Here again, the noise estimates for the cemented installation in Figure 5.4 are biased upwards at long periods due to the high noise levels of the warpless installation. However, comparing Figure 5.3 with 5.4 indicates that the warpless installation becomes noticeably noisier than the cemented installation above about 20 seconds. Above 70 seconds, the noise levels for the aluminum base plate warpless housing (Figure 5.3) are slightly higher than those for the vented sand installation (Figure 4.3).

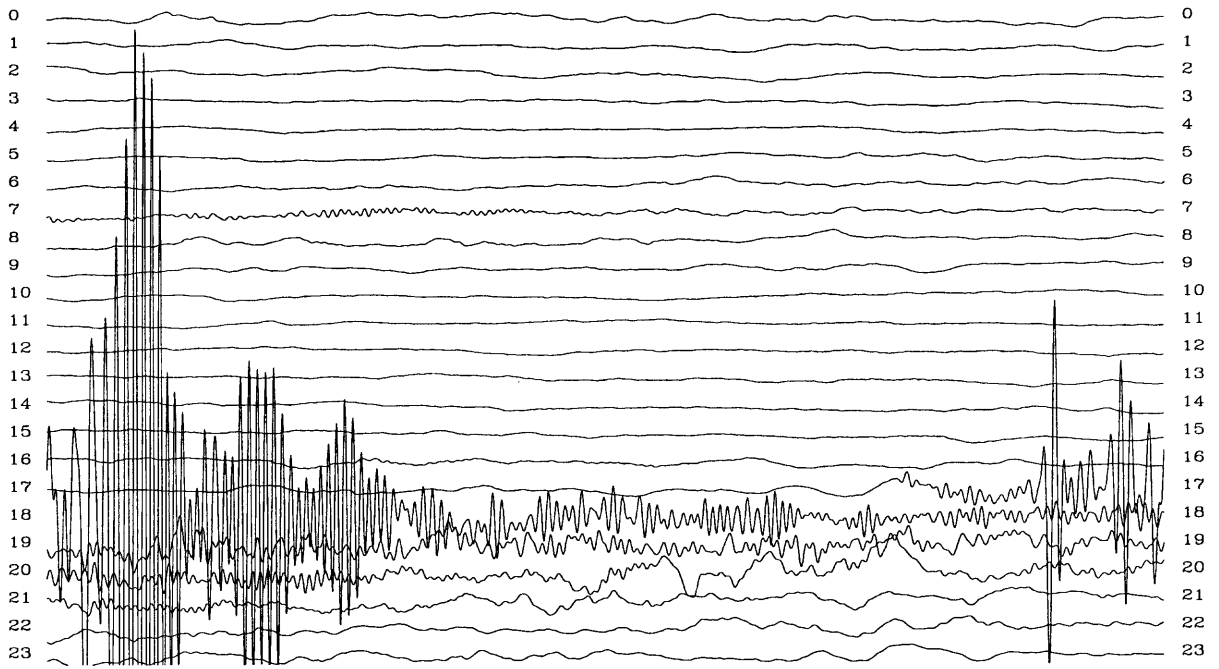

Figure 5.1 Time record for day 161 from a STS-1 horizontal sensor installed in a warpless housing with an aluminum

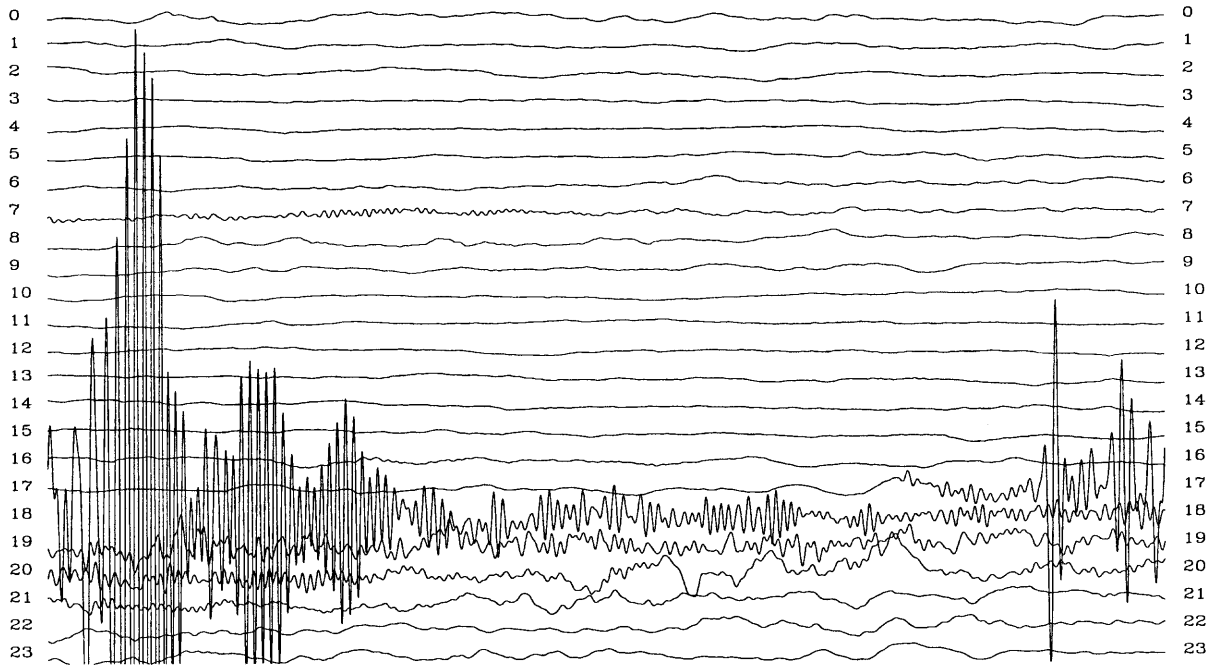
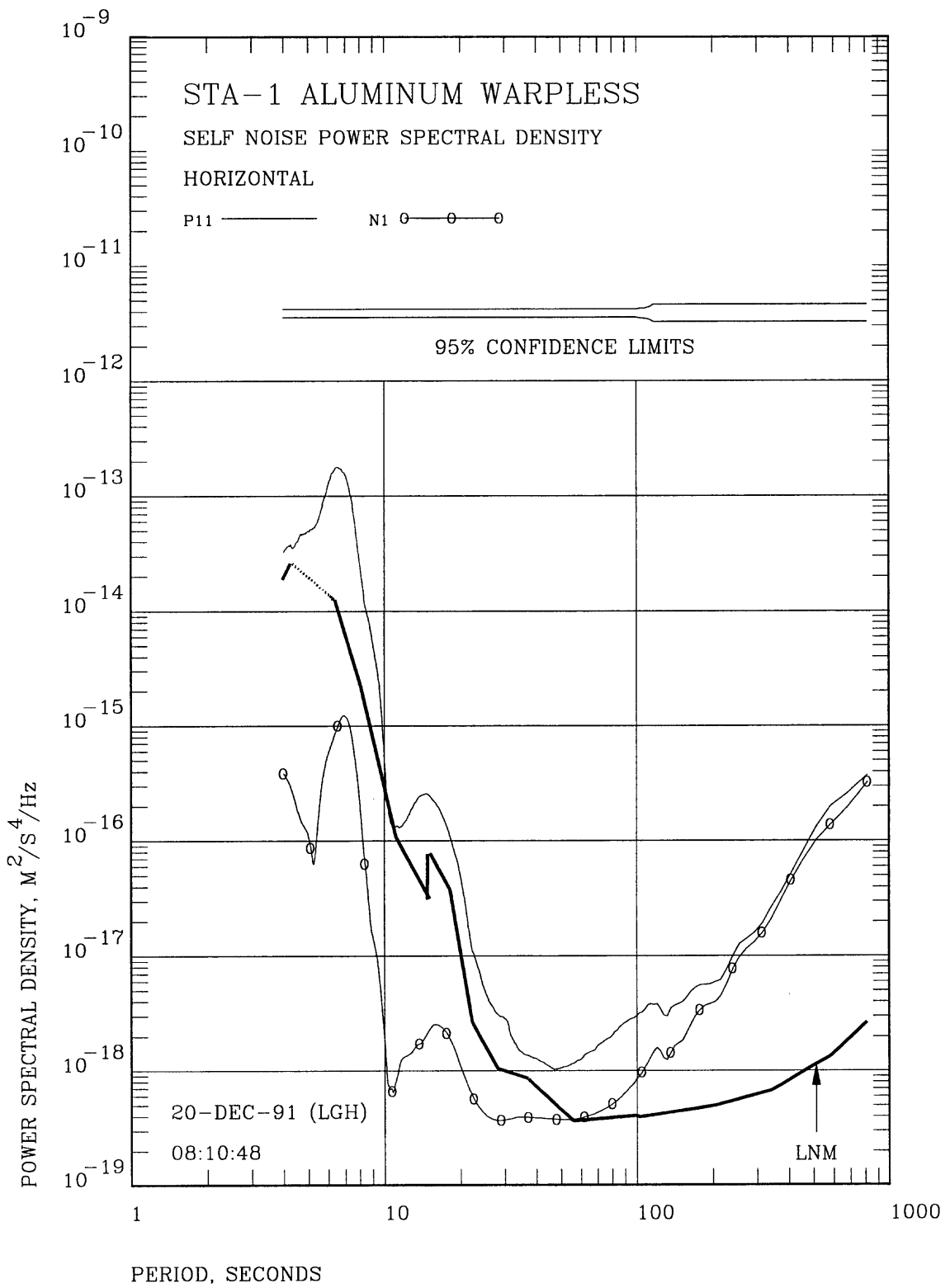

Figure 5.2 Time record for day 161 from a STS-1 horizontal sensor installed on a glass plate cemented to the floor under a sealed glass bell jar.



**Figure 5.3 Estimated noise level of a STS-1 horizontal sensor installed in a warpless housing with an aluminum base plate under a sealed plastic bell jar.**

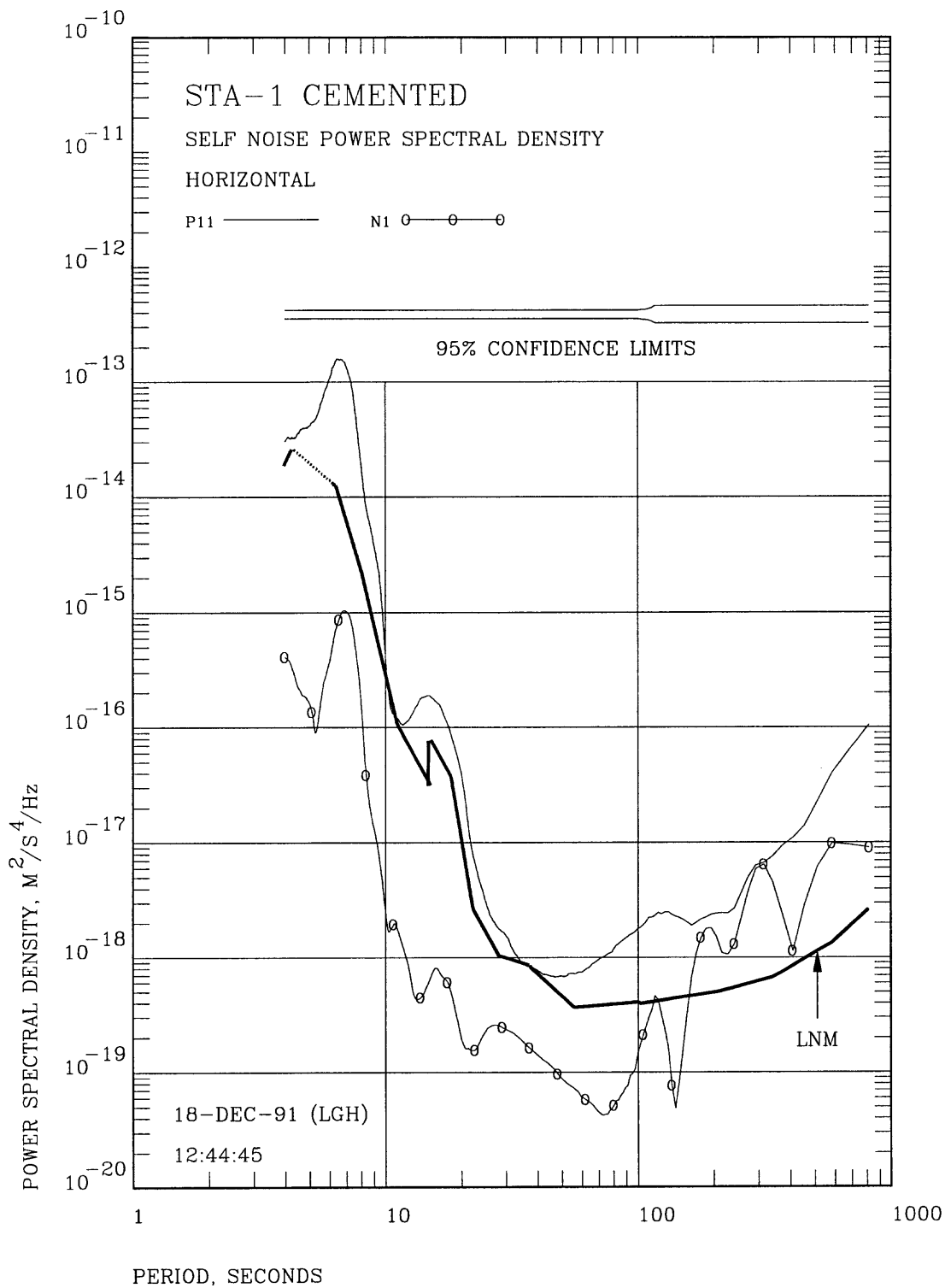

Figure 5.4 Estimated noise level of a STS-1 horizontal sensor installed on a glass plate cemented to the floor under a sealed glass bell jar



## 6 ALUMINUM WARPLESS BASE PLATE WITH A VENTED PLASTIC BELL JAR

The effects of venting the plastic bell jar are investigated in this section. Experience in the past at ASL has shown that sealed containers deform under the influence of atmospheric pressure variation whereas venting the container eliminates bending. Housing deformation translates into tilt in horizontal instruments which generates long period noise during periods of high atmospheric pressure activity such as that experienced during windy conditions. If pressure generated tilt is responsible for the noise observed in Section 5, venting the bell jar should decrease this type of noise.

As far as is known, the installation was exactly the same as that described in Section 5 except that the bell jar was vented by removing the cor from the warpless SEIS-RING (see the DETAIL-1 drawing in the appendix). The sensor was then allowed to operate undisturbed in conjunction with the cemented system for approximately 11 days beginning at 1991,162,23:00:00.

The time record for the aluminum base plate warpless housing with a vented plastic bell jar for day 172 is shown in Figure 6.1. The corresponding time record for the cemented reference horizontal is in Figure 6.2. Differences in the two time domain records are readily observable particularly during hours 19 through 23 during which the wind was probably blowing.

Figures 6.3 and 6.4 contain noise estimates for the aluminum base plate housing with a vented plastic bell jar and the cemented installation respectively. The warpless housing noise level is still quite a bit above the level for the cemented installation at periods above approximately 20 seconds. Comparing Figure 6.4 for a sealed bell jar warpless housing with Figure 5.4 for a vented bell jar warpless housing indicates that venting the bell jar has had little if any effect on the estimated noise level for the installation. This result is counter to the arguments presented elsewhere in this report and may indicate that an additional process is contributing to the noise levels in this installation.

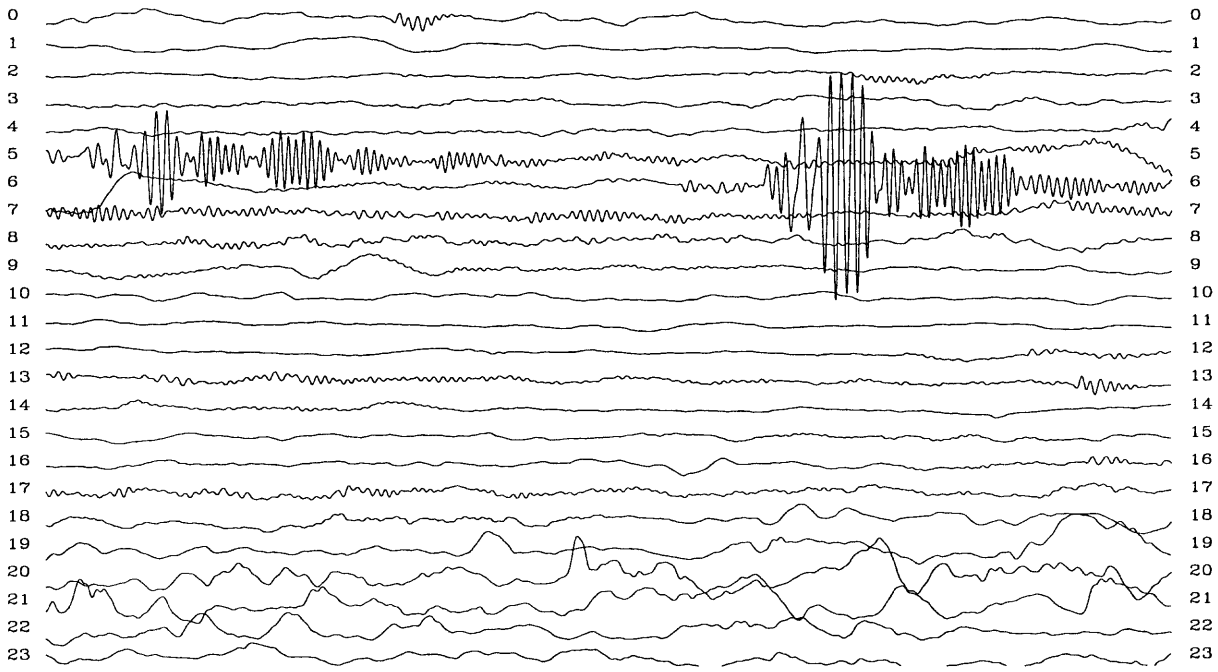

Figure 6.1 Time record for day 172 from the STS-1 horizontal sensor installed in a warpless housing under a vented plastic bell jar.

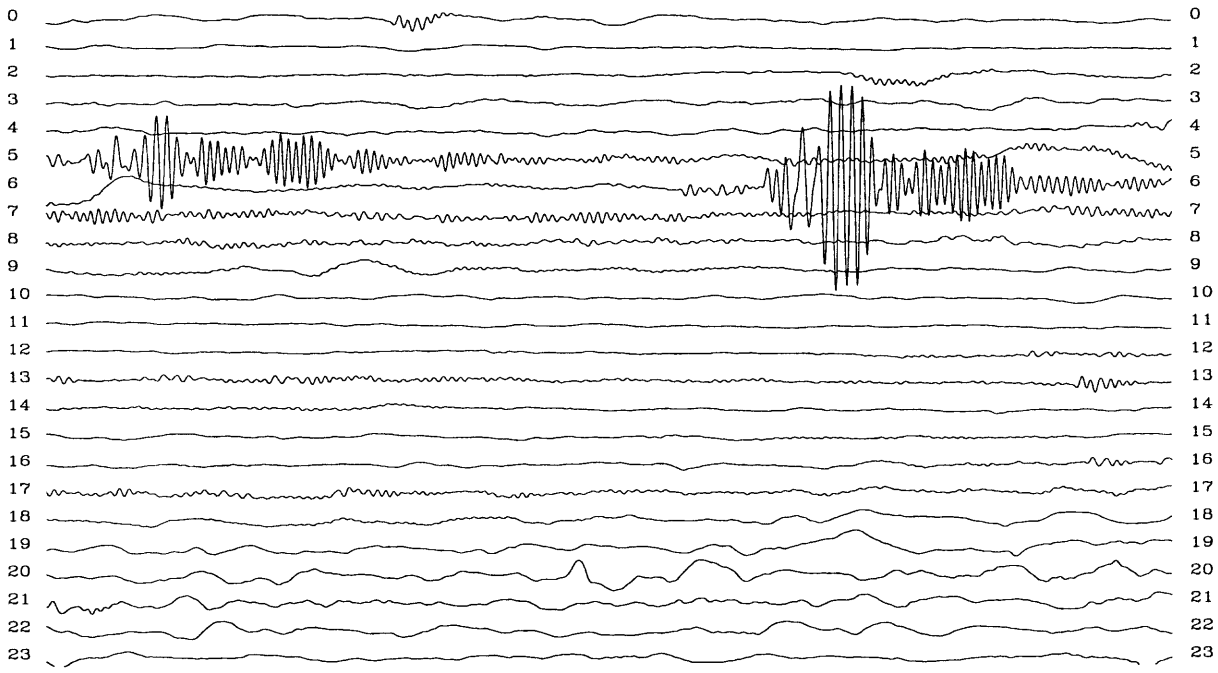

Figure 6.2 Time record for day 172 from the STS-1 horizontal sensor installed on a glass plate cemented to the floor under a sealed glass bell jar.

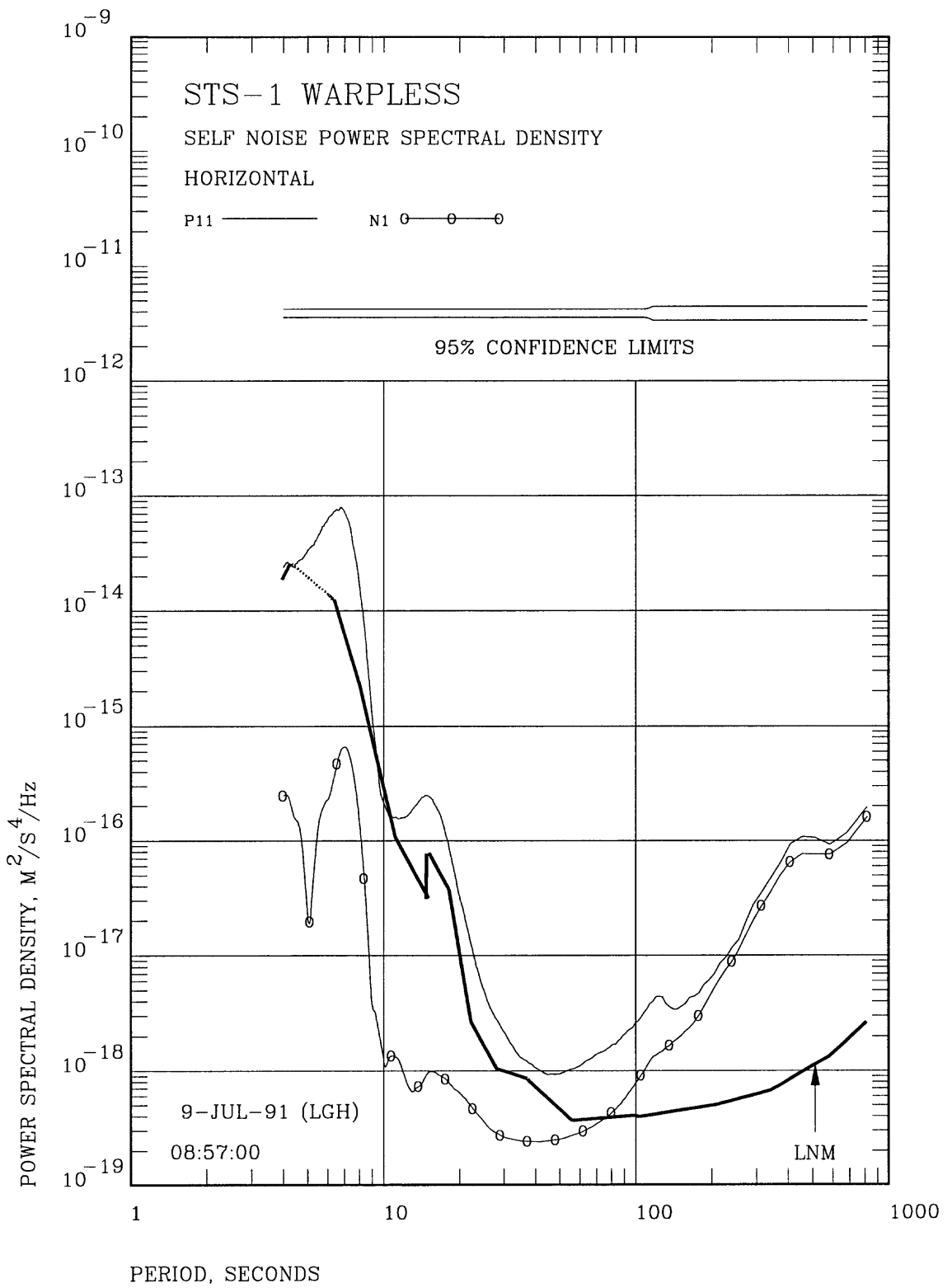

Figure 6.3 Estimated noise level of a STS-1 horizontal sensor installed in a warpless housing under a vented glass bell jar.

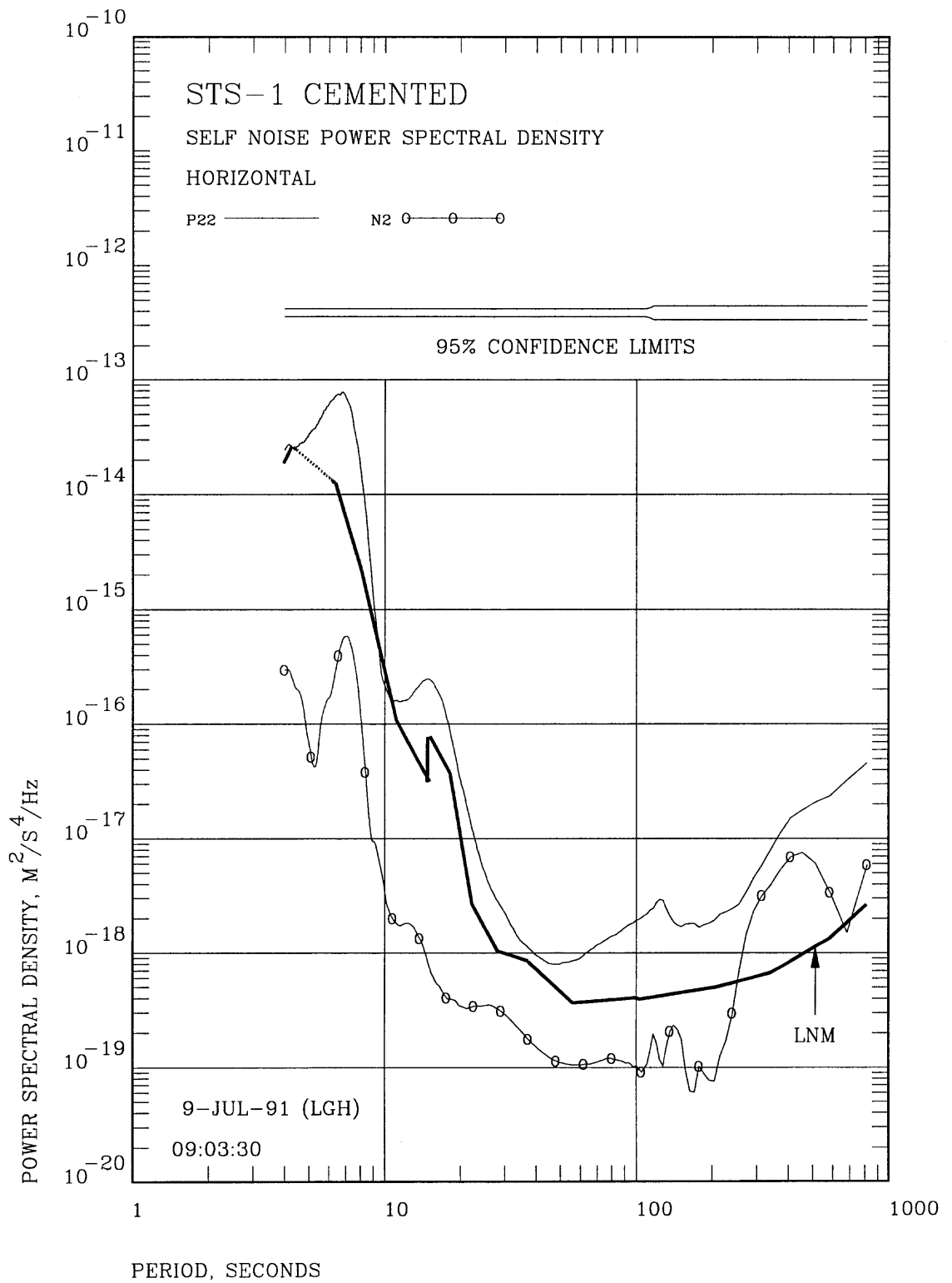

Figure 6.4 Estimated noise level of a STS-1 horizontal sensor installed on a glass plate cemented to the floor under a sealed glass bell jar

## 7 STAINLESS STEEL WARPLESS BASE PLATE WITH A SEALED PLASTIC BELL JAR

The performance of the aluminum base plate warpless housing in the tests presented in Sections 5 and 6 was somewhat disappointing. Estimated noise levels were higher than desired in both the sealed and vented experiments. Therefore, a new base plate was fabricated from stainless steel stock to increase the rigidity of the base plate.

The new warpless housing with the stainless steel base plate and a sealed plastic bell jar was installed in the ASL vault with a horizontal STS-1 sensor in it and operated undisturbed along side the cemented installation for approximately 5 days starting at 1991,220,23:00:00.

The time record for the stainless steel base plate warpless housing installed horizontal STS-1 is shown in Figure 7.1 and the corresponding time record for the cemented instrument is in Figure 7.2. These two figures are remarkably similar throughout most of the 24 hour period. One large excursion is visible at approximately 0250 in the warpless housing data, but otherwise differences are quite small. Careful study will reveal that the warpless data in Figure 7.1 contains more long period roll during hours 0 through about hour 11 than does the cemented data of Figure 7.2 during the same time period. The data between hours 18 through 23 is visually highly coherent.

The estimated noise levels for the stainless steel base plate warpless housing as shown in Figure 7.3 are quite low. They compare quite favorably with the estimated noise levels for the cemented STS-1 in Figure 7.4. The noise estimates for the two installation methods are quite comparable out to periods near 60 seconds. Between 60 and 120 seconds, the warpless noise estimate is below the cemented estimate, but above 120 seconds, the warpless noise estimate lies somewhat above the cemented noise estimate.

The data presented in Figures 7.1 through 7.4 was obtained during quiet time periods. In particular, windy time periods were edited out of the noise analysis process by the segment selection scheme described in Section 2. Housing performance under windy conditions is important because atmospheric pressure variations in the long period band become more intense when the wind is blowing. Therefore, a short windy time period was analyzed to document housing performance under windy conditions.

Figures 7.5 and 7.6 contain 3 hour long somewhat windy time histories of the outputs of the stainless steel warpless housing and the cemented installation respectively. Note that the apparent anomaly during the first five minutes or so of each record, which is particularly evident in Figure 7.6, is generated by the 15 second lowpass digital filtering of the data prior to creating the time domain figures. Visually, these two figures are highly coherent as one should expect them to be under high signal conditions.

Figures 7.7 and 7.8 contain the PSD results computed from analyzing all of the data contained in the 3 hour time period shown in Figures 7.5 and 7.6; 100 % of the data was included in the

analysis. Note that the total PSD out of both sensors lies considerably above the LNM above approximately 20 seconds. This excess power is being generated by the wind; it is probably real ground tilt. Both the levels and the shape of the total PSD out of both installations are essentially the same and the calculated noise PSD levels of the two systems are also approximately equal.

The data produced by the stainless steel base plate warpleless housing indicates that this design performs essentially as well as the cemented installation. Both the quiet background and the windy condition performance of the stainless warpleless housing installation produce estimated noise levels at nearly the same low levels as does a cemented installation.

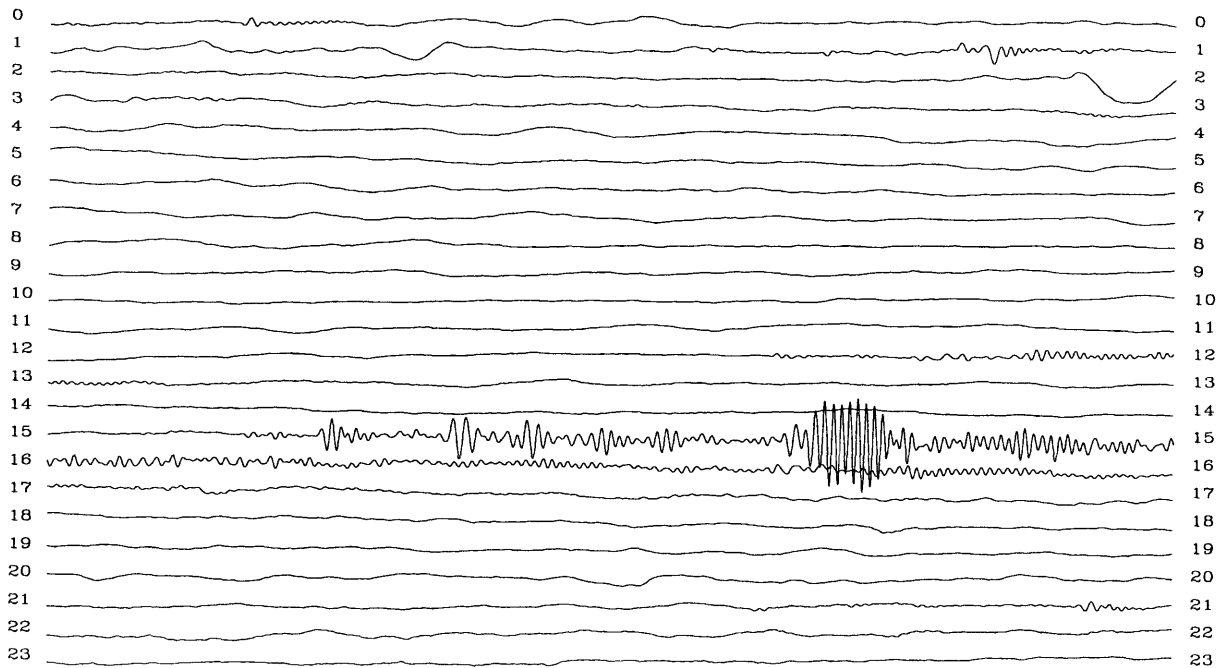

Figure 7.1 Time record for day 223 of a STS-1 horizontal sensor installed in a warpless housing with a stainless steel base plate under a sealed plastic bell jar.

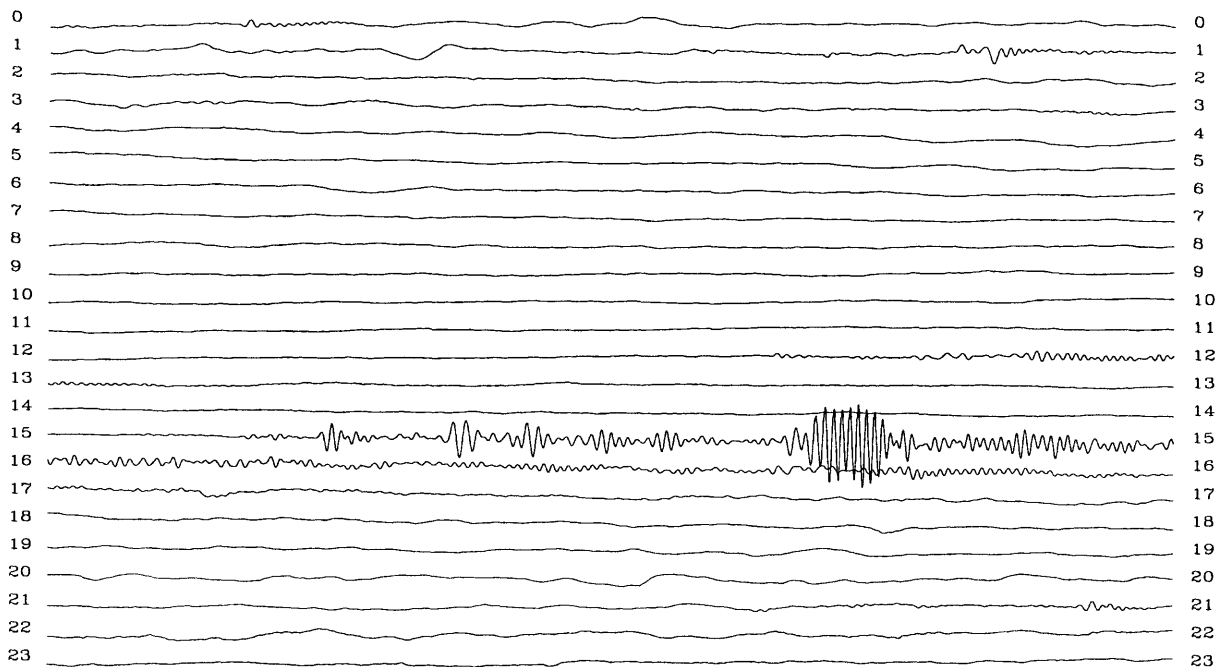
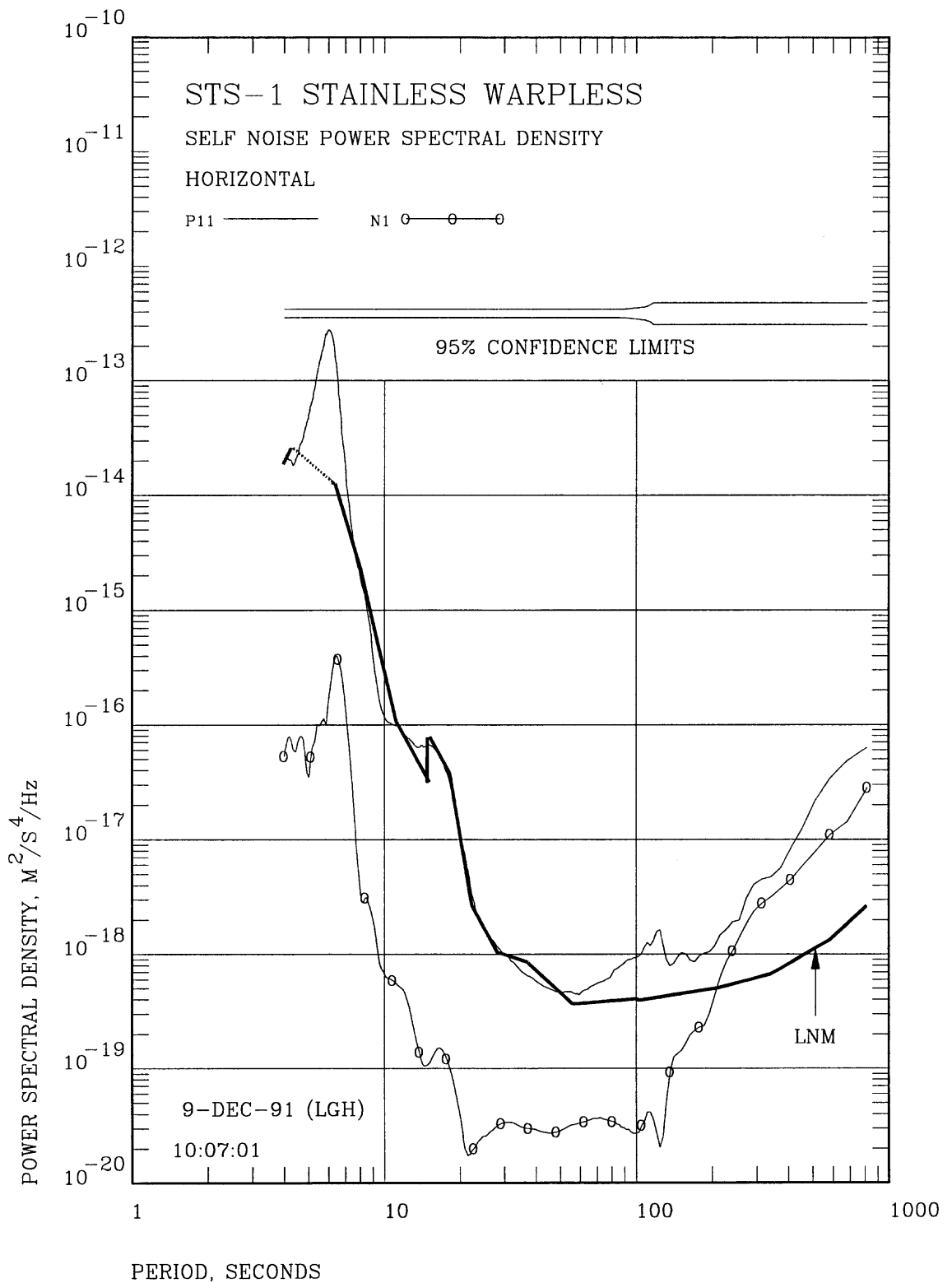

Figure 7.2 Time record for day 223 of a STS-1 horizontal sensor installed on a glass plate cemented to the floor under a sealed glass bell jar.



**Figure 7.3** Estimated noise level of a STS-1 horizontal sensor installed in a warpless housing with a stainless steel base plate under a sealed plastic bell jar.



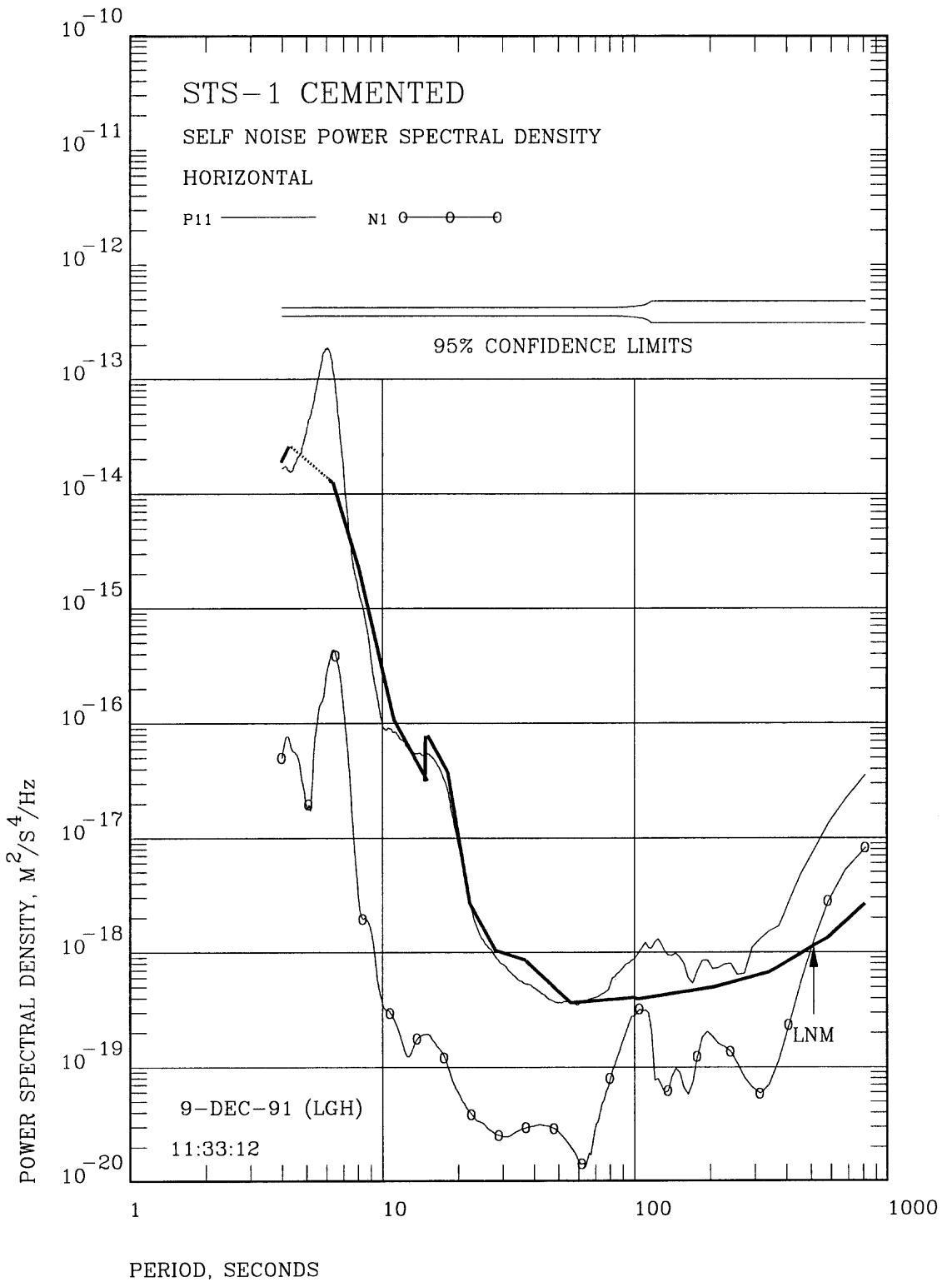

Figure 7.4 Estimated noise level of a STS-1 horizontal sensor installed on a glass plate cemented to the floor under a sealed glass bell jar.

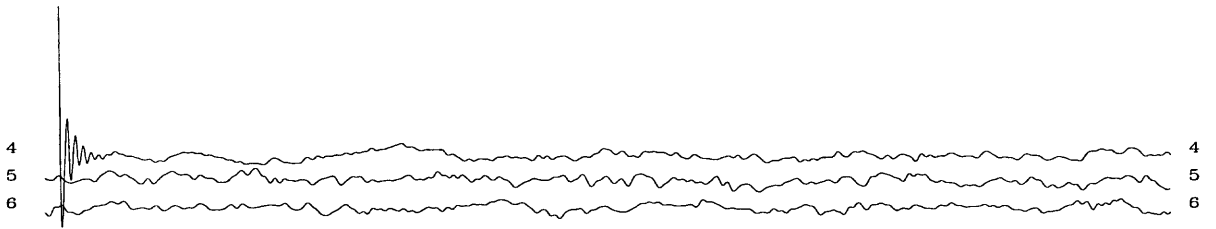

Figure 7.5 Time record for day 221 of a STS-1 horizontal sensor installed in a warpless housing with a stainless steel base plate under a sealed plastic bell jar under windy conditions.

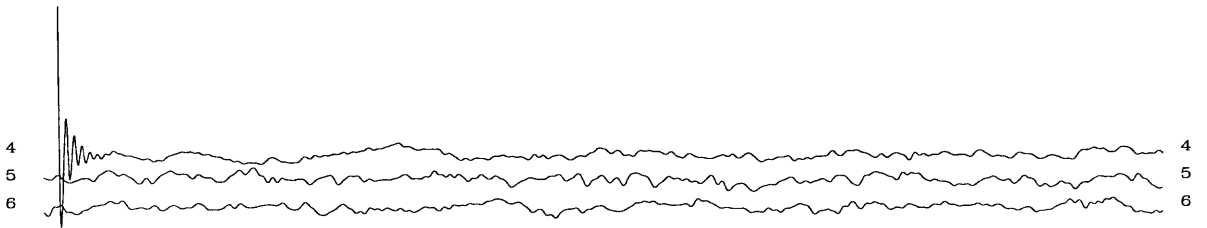
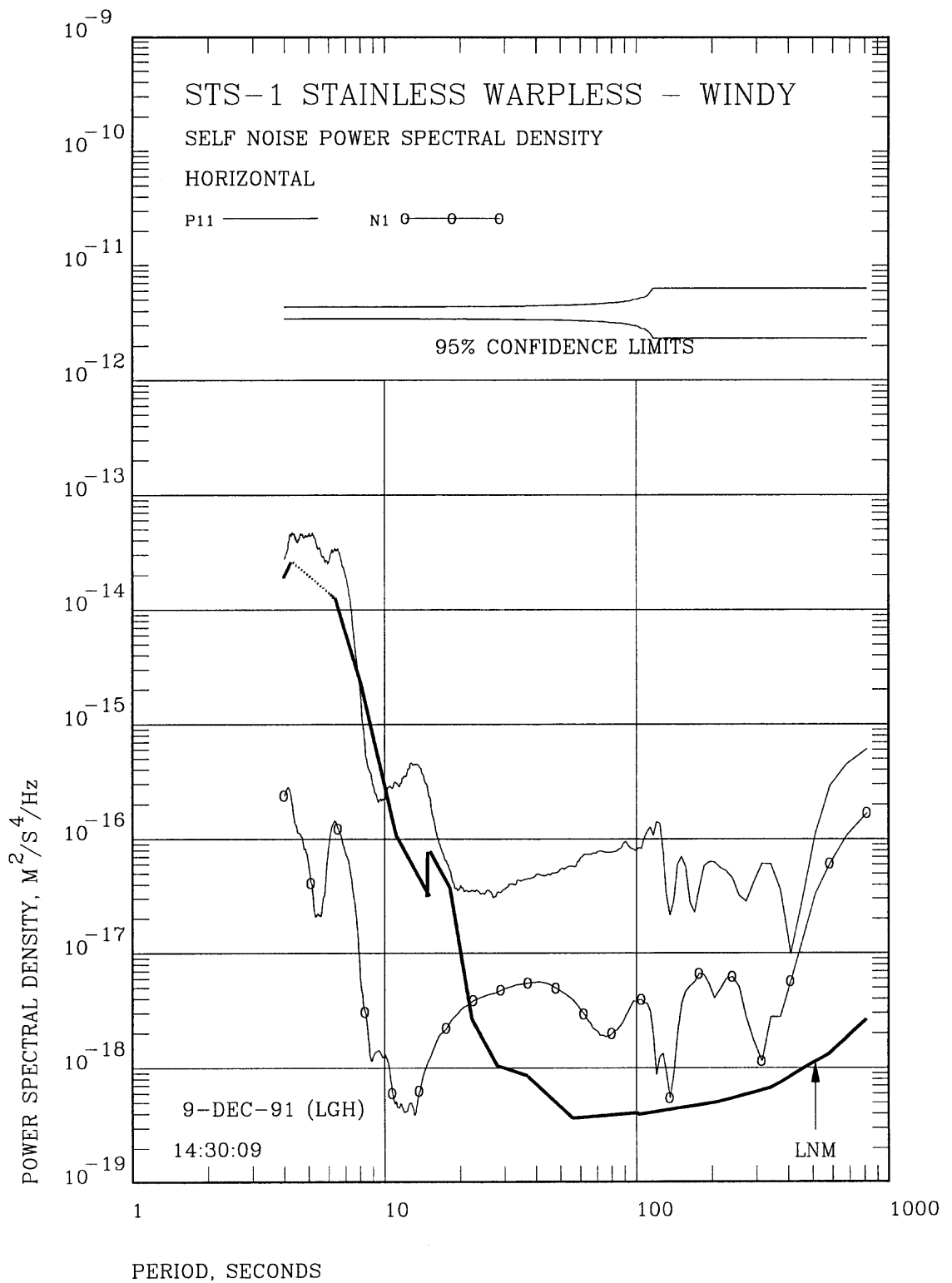

Figure 7.6 Time record for day 221 of a STS-1 horizontal sensor installed on a glass plate cemented to the floor under a sealed glass bell jar under windy conditions.



**Figure 7.7** Estimated noise level of a STS-1 horizontal sensor installed in a warpless housing with a stainless steel base plate under a sealed plastic bell jar under windy conditions.

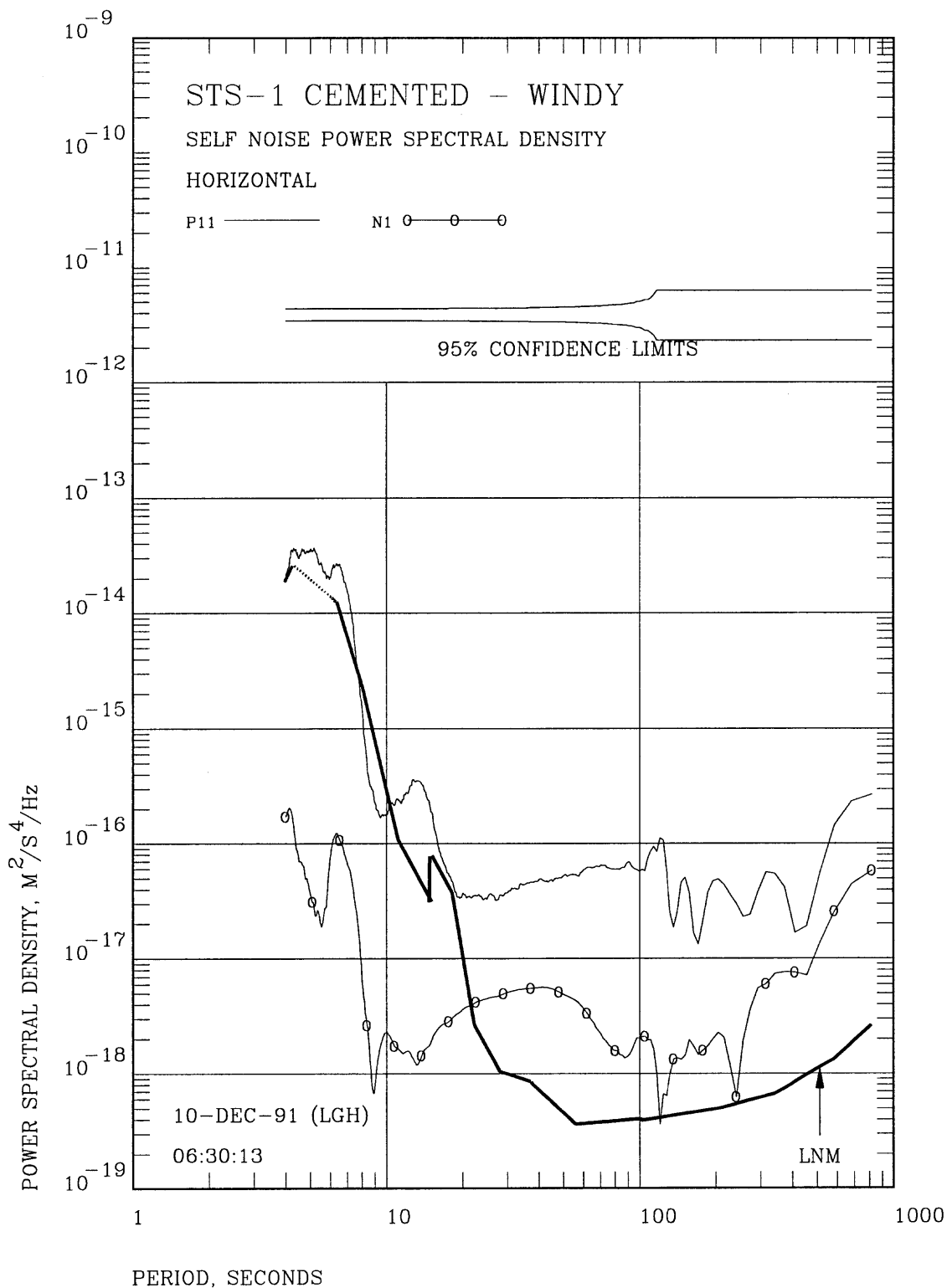

Figure 7.8 Estimated noise level of a STS-1 horizontal sensor installed on a glass plate cemented to the floor under a sealed glass bell jar under windy conditions.



## 8 RELATIVE COSTS

A warpless housing installation will cost more than either a cemented or vented sand installation because the additional hardware involves mechanical machine work. However, this cost is partially offset by the fact that some of the hardware usually supplied as part of a standard STS-1 purchase (glass base plate, glass bell jar etc.) is not required in a warpless housing installation. Early in 1991, the savings in the original purchase of a 3 component STS-1 warpless installation was approximately \$2000 (this figure will float around depending on the foreign exchange rate). The added cost of the additional warpless hardware, most of which as produced by a local Albuquerque machine shop, was approximately \$4230 for a 3 component installation. Thus, the hardware differential between a warpless installation and a cemented or vented sand installation was approximately \$2230 per site.

The final installed cost differential is less than this figure because of the difference in on-site labor costs. A warpless installation will require a minimum amount of on-site labor, a vented sand installation should require only slightly more labor, but a cemented installation requires considerably more labor and on-site installation time for completion.

E. Wielandt has suggested that the cost of the stainless steel warpless housing could be further reduced by replacing the stainless steel plate with a thicker aluminum plate. The performance of a thicker aluminum plate will be evaluated at a future date.

## 9 CONCLUSIONS

The relative performance characteristics of three methods of installing horizontal STS-1 seismometers have been quantitatively evaluated.

Installing a horizontal STS-1 under a sealed plastic bell jar on a glass plate resting on sand generates incredible levels of long period noise. This noise is attributed to tilting of the sensors caused by flexing of the glass plate due to atmospheric pressure variations. Venting the bell jar in this type of installation eliminates the majority of this noise and converts a sand installation into a competitive alternative to cementing the glass plate to the vault floor. The vented installations in this report were simply vented directly to the atmosphere. An actual operational field installation would require some means of preventing humidity and insects from entering the sensor chamber. This can be achieved by a flexible bellows system or a desiccant container on the air inlet line.

The Wielandt designed warpless housing performs superbly with a stainless steel baseplate. It should prove to be an easily installed, highly portable method for installing horizontal STS-1 sensors.

Final installed system cost may prove to be an important criteria for determining the installation method chosen for a given site. A vented sand installation is the cheapest installation method but the vented sand long period noise levels presented in this report are higher than those found for the other two methods. However, the vented sand installation method performs quite well; it will meet the requirements of some programs. If absolute low noise performance at long periods must be achieved, a cement or stainless steel warpless housing installation must be made. These two types of installations produce essentially equal noise levels at similar final installed cost. The big difference between them is portability and ease of installation in the field. The warpless housing installation wins this contest hands down.

## 10 ACKNOWLEDGMENTS

Bob Young, ASL, generously supplied the mechanical drawings of the warpless housing. Special thanks go to E. Wielandt of the University of Stuttgart for the initial design of the warpless housing and an informative review of this report.



## 11 REFERENCES

Holcomb, L. Gary,(1989),"A Direct Method for Calculating Instrument Noise Levels in Side-by-Side Seismometer Evaluations":U.S.Geological Survey Open-File Report 89-214,35p.

Peterson, Jon,(1980),"Preliminary Observations of Noise Spectra at the SRO and ASRO Stations":U.S. Geological Survey Open-File Report 80-992,25p.

Peterson, Jon, Tilgner, E.,(1985),"Description and Preliminary Testing of the CDSN Seismic Sensor Systems":U.S. Geological Survey Open-File Report 85-188,60p.

## 12 APPENDIX

This appendix contains the mechanical drawings of the warpless housing. Although the dimensions on the drawings are virtually unreadable, the drawings are included so that the reader can get a basic idea of the design of the device. For readable drawings, please contact the Albuquerque Seismological Laboratory.



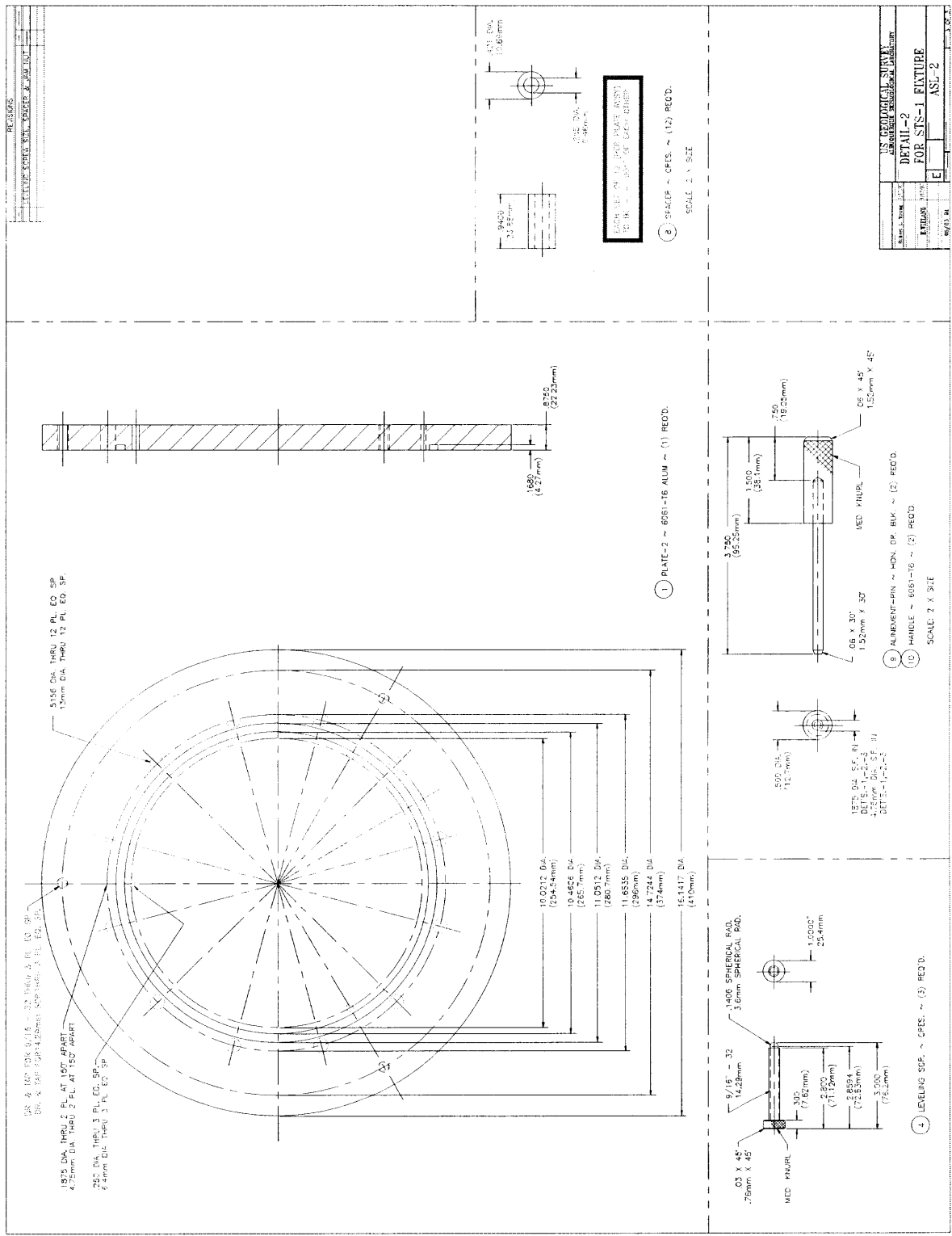

REVISIONS	
NO.	DESCRIPTION

NOTES:  
 1. CLASS PLATE TO BE EMPLOYED AND FINISHED BOTH SIDES  
 AND BANGED TO DETAIL A AND SECTION

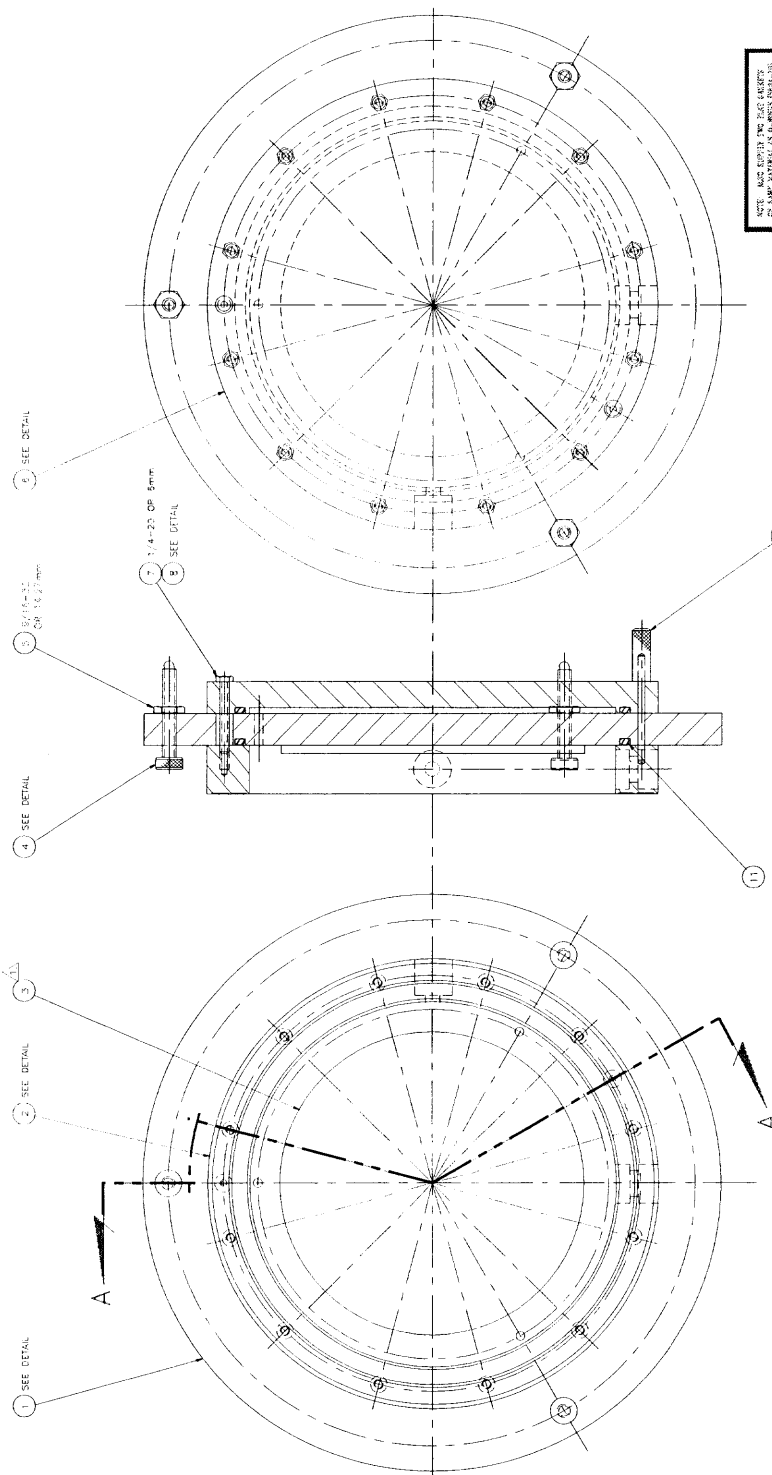

NOTE: ALL DIMENSIONS ARE IN INCHES UNLESS OTHERWISE SPECIFIED  
 DIMENSIONS IN PARENTHESIS ARE IN MILLIMETERS

NO.	DESCRIPTION	QTY	UNIT	REMARKS
11	11	1	PC	CLASS PLATE
10	10	1	PC	CLASS PLATE
9	9	1	PC	CLASS PLATE
8	8	1	PC	CLASS PLATE
7	7	1	PC	CLASS PLATE
6	6	1	PC	CLASS PLATE
5	5	1	PC	CLASS PLATE
4	4	1	PC	CLASS PLATE
3	3	1	PC	CLASS PLATE
2	2	1	PC	CLASS PLATE
1	1	1	PC	CLASS PLATE

ASSEMBLY CROSS SECTION FOR STS-1 FLUTTER	
NO.	DESCRIPTION
1	1
2	2
3	3
4	4
5	5
6	6
7	7
8	8
9	9
10	10
11	11

SECTION: A-A

NOTE: ALL DIMENSIONS ARE IN INCHES UNLESS OTHERWISE SPECIFIED