

# RECLAMATION

*Managing Water in the West*

Desalination and Water Purification Research  
and Development Program Report No. 144

## Barriers to Thermal Desalination in the United States



U.S. Department of the Interior  
Bureau of Reclamation

March 2008

# REPORT DOCUMENTATION PAGE

Form Approved  
OMB No. 0704-0188

Public reporting burden for this collection of information is estimated to average 1 hour per response, including the time for reviewing instructions, searching existing data sources, gathering and maintaining the data needed, and completing and reviewing this collection of information. Send comments regarding this burden estimate or any other aspect of this collection of information, including suggestions for reducing this burden to Department of Defense, Washington Headquarters Services, Directorate for Information Operations and Reports (0704-0188), 1215 Jefferson Davis Highway, Suite 1204, Arlington, VA 22202-4302. Respondents should be aware that notwithstanding any other provision of law, no person shall be subject to any penalty for failing to comply with a collection of information if it does not display a currently valid OMB control number. **PLEASE DO NOT RETURN YOUR FORM TO THE ABOVE ADDRESS.**

<b>1. REPORT DATE</b> (DD-MM-YYYY) March 2008		<b>2. REPORT TYPE</b> Final		<b>3. DATES COVERED</b> (From - To) October 2005 – December 2007	
<b>4. TITLE AND SUBTITLE</b> Barriers to Thermal Desalination in the United States				<b>5a. CONTRACT NUMBER</b> Agreement No. 04-FC-81-1154	
				<b>5b. GRANT NUMBER</b>	
				<b>5c. PROGRAM ELEMENT NUMBER</b>	
<b>6. AUTHOR(S)</b> John Tonner				<b>5d. PROJECT NUMBER</b>	
				<b>5e. TASK NUMBER</b> Task B	
				<b>5f. WORK UNIT NUMBER</b>	
<b>7. PERFORMING ORGANIZATION NAME(S) AND ADDRESS(ES)</b> Water Consultants International 10201 N. Concord Drive Mequon, Wisconsin 53097				<b>8. PERFORMING ORGANIZATION REPORT NUMBER</b>	
<b>9. SPONSORING / MONITORING AGENCY NAME(S) AND ADDRESS(ES)</b> U.S. Department of the Interior Bureau of Reclamation Denver Federal Center PO Box 25007, Denver CO 80225-0007				<b>10. SPONSOR/MONITOR'S ACRONYM(S)</b>	
				<b>11. SPONSOR/MONITOR'S REPORT NUMBER(S)</b> DWPR Report No. 144	
<b>12. DISTRIBUTION / AVAILABILITY STATEMENT</b> Available from the National Technical Information Service Operations Division, 5285 Port Royal Road, Springfield VA 22161					
<b>13. SUPPLEMENTARY NOTES</b> Report can be downloaded from Reclamation Web site: <a href="http://www.usbr.gov/pmts/water/publications/reports.html">www.usbr.gov/pmts/water/publications/reports.html</a>					
<b>14. ABSTRACT (Maximum 200 words)</b> This report quantifies where thermal desalination processes should be competitive, citing examples and documenting regulations and practices that are impeding the implementation of thermal desalination in the United States. This was accomplished through the following series of steps: <ul style="list-style-type: none"> <li>• Investigating our domestic power market regulations and practices (both State and national)</li> <li>• Summarizing the Federal Energy Regulatory Commission's (FERC) cogeneration policies</li> <li>• Profiling existing industrial and dual-purpose power/water cogeneration projects</li> <li>• Discussing carbon footprint and prime energy consumption of various desalination processes</li> <li>• Outlining target criteria for future cogeneration applications</li> <li>• Discussing exergistic analyses of single-purpose and dual-purpose desalination plants</li> </ul> <p>Note: Exergistic analysis involves a detailed review of all energy consumed in a process and all products or services the process provides. This is in contrast to simpler methods which focus on conversion of fuel into a single product (e.g., electricity) and does not consider that additional products can be cogenerated from the same primary source and quantity of energy.</p>					
<b>15. SUBJECT TERMS</b> Brackish Water Treatment, Carbon Footprint, Cogeneration, Desalting, Distiller, Evaporator, Exergy, Hybrid Desalination, Multi-Stage Flash Distillation, Multi-Effect Distillation, Reverse Osmosis, Seawater Treatment, Thermal Desalination, Thermal Energy, Vapor Compression, Waste Heat					
<b>16. SECURITY CLASSIFICATION OF:</b> UL			<b>17. LIMITATION OF ABSTRACT</b> SAR	<b>18. NUMBER OF PAGES</b> 53	<b>19a. NAME OF RESPONSIBLE PERSON</b> Harry Remmers
<b>a. REPORT</b> UL	<b>b. ABSTRACT</b> UL	<b>c. THIS PAGE</b> UL			<b>19b. TELEPHONE NUMBER</b> (include area code) 303-445-2261

**Desalination and Water Purification Research  
and Development Program Report No. 144**

# **Barriers to Thermal Desalination in the United States**

**Prepared for Reclamation Under Agreement No. 04-FC-81-1154**

*by*

**John Tonner**

**Water Consultants International  
Mequon, Wisconsin**



**U.S. Department of the Interior  
Bureau of Reclamation  
Technical Service Center  
Water and Environmental Services Division  
Water Treatment Engineering Research Team  
Denver, Colorado**

**March 2008**

## MISSION STATEMENTS

The mission of the Department of the Interior is to protect and provide access to our Nation's natural and cultural heritage and honor our trust responsibilities to Indian tribes and our commitments to island communities.

---

The mission of the Bureau of Reclamation is to manage, develop, and protect water and related resources in an environmentally and economically sound manner in the interest of the American public.

### **Disclaimer**

The views, analysis, recommendations, and conclusions in this report are those of the authors and do not represent official or unofficial policies or opinions of the United States Government, and the United States takes no position with regard to any findings, conclusions, or recommendations made. As such, mention of trade names or commercial products does not constitute their endorsement by the United States Government.

# Acknowledgements

Water Consultants International wishes to thank the Bureau of Reclamation and its Desalination and Water Purification Research (DWPR) Program for sponsoring this project as well as the following individuals for their guidance and assistance throughout the project:

Frank Leitz – Program Manager, DWPR Program

Harry Remmers – Grant and Cooperative Agreement Officer's Technical Representative

# Glossary

ADWED	Abu Dhabi Water and Electricity Authority
AMPCO	Atlantic Methanol
AVR	Afvalverwerking (Dutch for “Treatment of Waste”)
BOO	build/own/operate
Btu/lb	British thermal units per pound
CAPEX	capital costs
CCX	Chicago Climate Exchange
CDM	clean development mechanism
CFR	Code of Federal Regulations
DBB	design/bid/build
DBOO	design/build/own/operate
DBOOT	design/build/own/operate/transfer
DWPR	Desalination and Water Purification Research
FERC	Federal Energy Regulatory Commission
GCC	Gulf Cooperation Council (Bahrain, Kuwait, Oman, Qatar, Saudi Arabia and the United Arab Emirates)
GOR	gained output ratio
gpd	gallons per day
gpm	gallons per minute
GTTPC	Gulf Total Tractebel Power Company
HRSG	heat recovery steam generator
ISO	independent systems operators
IWP	independent water producer
IWPP	independent water and power producer
kgH <sub>2</sub> O	kilograms of water
KGRA	known geothermal resource area
kWh <sub>e</sub> /m <sup>3</sup>	kilowatthours (electric) per cubic meter
kWh <sub>th</sub> /m <sup>3</sup>	kilowatthours (thermal) per cubic meter
lb of H <sub>2</sub> O	pounds of water
m <sup>3</sup> /d	cubic meters per day
MED	multiple effect distillation
MGD or mgd	million gallons per day
MIGD	million Imperial gallons per day
MSF	multistage flash
MVC	mechanical vapor compression
MW	megawatts
OPEX	operating costs
PG&E	Pacific Gas and Electric

## Glossary (continued)

PJM	Pennsylvania, Jersey, Maryland Power Pool, an RTO which has expanded to other States since it was created
PR	Performance Ratio
psig	pounds per square inch gauge
PTA	terephthalic acid
PURPA	Public Utility Regulatory Policy Act of 1978
PV	photovoltaic
PWPA	Power and Water Purchase Agreement
QF	qualifying facility
RO	reverse osmosis
RSB	Regulatory Services Bureau (UAE)
RTO	regional transmission organizations
SPC	special purpose company
SWRO	seawater reverse osmosis
t/h	tons per hour
TDA	U.S. Trade and Development Agency
TDS	total dissolved solids
TVC	thermal vapor compression
UNFCCC	United Nations Framework Convention on Climate Change
water stress	Water stress occurs when the demand for water exceeds the amount available during a certain period or when poor quality restricts its use (UNEP definition).
WEB	Water en Energieberijf, Aruba
WED	Water and Electricity Authority, Abu Dhabi
WPA	Water Purchase Agreement

# Table of Contents

	<i>Page</i>
Glossary .....	v
1 Executive Summary .....	1
2 Relevant Definitions .....	2
3 Discussion of Findings.....	6
3.1 Minimum Energy of Separation.....	6
3.2 Cogeneration.....	7
3.3 Maximum Thermal Efficiency Not Always Justified.....	11
3.4 Waste Heat.....	14
3.5 Cogeneration in Practice.....	15
3.6 U.S. Power and Cogeneration.....	17
3.7 Public-Owned Treatment Works or Long-Term Purchase of Water? .....	21
3.8 Heat Rate, Exergy, and Cogeneration Policy.....	23
3.9 Carbon Footprint and Potential Use of Renewable Energy Sources .....	24
3.10 Potential Application Guidance and Recommendations.....	27
Appendix A—Al Taweelah Desalination Facility (UAE).....	31
Appendix B—Shuweihat Desalination Plant (UAE).....	39

## List of Tables

### *Table*

1 Power-to-Water Ratio (MSF) .....	10
2 Power-to-Water Ratio (MED).....	11

## List of Figures

### *Figure*

1 Distillation Energy Consumption .....	5
2 Block Diagrams for Generic Desalination of Seawater .....	8
3 Block Diagram for Waste Heat Thermal Desalination.....	10
4 Power Generation Utilizing Steam Turbine.....	10
5 Power Generation Utilizing Combined Cycle .....	10
6 Distiller GOR Versus Capital Expenditures (CAPEX) and Operating Expenditures (OPEX).....	13
7 AVR Rotterdam Waste Incinerator .....	16
8 Fujairah, UAE Hybrid Cogeneration .....	16
9 Exergy Cost Allocations .....	24
10 Generic Diagram for Solar (or Geothermal) Power and Water Production .....	25



# 1. Executive Summary

The Bureau of Reclamation (Reclamation) awarded a project to Water Consultants International to study “Barriers to Thermal Desalination in the United States.” The purpose of the study was to objectively quantify where thermal desalination processes should be competitive, citing examples, and documenting regulations and practices that impede the implementation of thermal desalination in the United States.

This report presents the results and explains various cogeneration techniques that are used internationally, highlighting the significant differences these have from definitions and expectations of “cogeneration” within the United States. Thermal desalination is often erroneously compared to other desalting processes based on the heat being produced by the direct combustion of fossil fuels. In fact, most thermal desalination systems operating internationally utilize heat from secondary sources, such as waste or byproduct heat which would otherwise be discarded.

Initially, this project had the following objectives as they relate to the subject – “Barriers to Thermal Desalination in the United States”:

- Investigate our domestic power market regulations and practices (both State and national)
- Summarize Federal Energy Regulatory Commission’s (FERC) Cogeneration Policy
- Profile existing industrial and dual-purpose power/water cogeneration projects
- Outline target criteria for future cogeneration applications

These objectives were later modified to also include exergistic analyses of single-purpose and dual-purpose desalination plants. Exergistic analyses involve a detailed review of all energy consumed in a process and all products or services the process provides; this is in contrast to simpler methods that focus on conversion of fuel into a single product (e.g., electricity) and does not consider that additional products can be cogenerated from the same primary source and quantity of energy.

## 2. Relevant Definitions

### *What is thermal desalination and what is a distiller?*

Thermal desalination is a process that involves changing saline water into vapor. This vapor, or steam, is generally free of the salt, minerals, and other contaminants that were in the saline water. When condensed, this vapor forms a high-purity distilled water. There are several different methods of achieving this distillation. The quality of water produced and the heat consumed in its production can both be defined when the system is designed. The efficiency of these systems covers an order of magnitude. The selected efficiency is project-specific and reflects the increased capital cost for higher efficiency designs that is offset by a lower operating (energy) cost. Conversely, where low cost or low-grade thermal energy is utilized, there is economic justification in utilizing lower efficiency designs.

A distiller produces distilled water. When water must be re-mineralized for potability, there may be no advantage in producing high-quality distillate. When water is required for industrial purposes, there is an economic and process gain obtained from using distilled water rather than reverse osmosis (RO) permeate (which often must be treated further by RO and/or polished by another treatment process).

Distillation is, from a practical perspective, a macroscopic process. Vapor chambers are large enough for inspections by groups of people. Tubes can be visually inspected with the naked eye as can most other components. This is in contrast to the active surfaces of a membrane process such as RO that operates on a microscopic level and can only be inspected as part of a destructive autopsy. Distillers require simple screening as pretreatment and are more tolerant to changes in intake water quality. Oxidants such as chlorine can cause problems in distillers, but this is orders of magnitude lower than the potential impact they have on current RO membranes.

### *How is thermal desalination different from membrane processes like RO?*

There are a few RO plants that operate using fossil-fuel-driven pumps, usually diesel-engine pumps in remote locations. There is talk about a large RO project at the low elevation of the Dead Sea being fed with water flowing downhill from the Red Sea; the elevation difference reportedly is adequate to cover most or all of the pressure required to drive the RO process. However, for the most part, all RO systems utilize electric-driven motors; they use a prime source of energy that could otherwise be used elsewhere or not generated in the first place. Even when these electric RO plants are connected to renewable energy sources such as wind farms, they are consuming prime energy that otherwise could be used elsewhere.

Distillers also require pumping, but depending upon the distillation process, this can be one-third of the electric power required by RO (when considering seawater desalting). Distillers need heat in addition to pumping power. If fossil fuels are burned to provide the heat for thermal desalination, it will never be economically competitive with other desalting processes like RO. If thermal desalination units are heated with the byproduct of electricity generation – heat that is often discharged to the environment via heat exchangers or cooling towers – then the economics and efficiency can fall in favor of distillers.

### ***Why cogenerate power and water?***

Most all power and water cogeneration facilities have a common thread no matter where they are located globally: the offtaker accepts both products, and the regulatory framework of the country was developed for water and power simultaneously under the auspices of a single government agency. From Aruba (in the Caribbean) to Saudi Arabia and points in between, water and power are systematically linked. Water-En Energiebedrijf (WEB), which is Aruba's electricity and water authority, celebrated 75 years of cogeneration in 2007, while neighboring Curaçao will celebrate 80 years of cogeneration in 2008. The Arabian Peninsula nations have cogenerated for over 40 years, as have the United States Virgin Islands.

The lure of cogeneration is quite simply to try to use the heat from burning fuel for two purposes: first to turn turbines and make electricity, secondly to condense in a desalination plant and make water. Even with single-purpose power generation, the steam must be condensed and the heat dissipated to the environment, typically via cooling towers or condensers cooled by surface water. The attraction is then obvious: instead of throwing the heat away, utilize it in a linked process – desalination.

There have been many detailed analyses of cogeneration from an efficiency perspective, which will be covered later in detail. An exergetic analysis is when the First Law of Thermodynamics is used to analyze the efficiency of a process. All exergetic analyses show that cogeneration is significantly more efficient than generating power and water in two disconnected processes. Cogeneration should, therefore, be more economical and environmentally friendly than the alternative (this statement assumes that desalination is required for any case being studied).

Desalination processes require significant quantities of feedwater and energy. Co-locating the desalination process with a power generation facility, therefore, is a practical benefit, even if the two production processes are not intrinsically linked.

***Why are the terms Gained Output Ratio and Performance Ratio important design parameters for a thermal desalination system?***

Gained Output Ratio (GOR) is a measure of how much thermal energy is consumed in a desalination process, typically defined as the number of kilograms of distilled water produced per kilogram of steam consumed, i.e.,

$$GOR = \frac{kg_{H_2O}}{kg_{steam}} = \frac{lb_{H_2O}}{lb_{steam}}$$

Obviously, the GOR value is the same when the United States (U.S.) customary units of pounds are used (figure 1).

The value of GOR generally ranges from 1 to 10:1. Lower values are typical of applications where there is a high availability of low-value thermal energy. Higher values, as high as 18:1, have been associated with situations where local energy values are very high, when the local value or need for water is high, or a combination of both.

GOR should be considered at the design stage of a desalination system when the quantity and economic value of energy and water can be used to compare the capital and operating costs of units with different GORs. Typically, higher GOR systems cost more but consume less energy and, therefore, have lower operating costs (at least the energy component of operating cost is lower).

Performance Ratio (PR) is a closely related measurement, but slightly more technically defined. PR was developed from the U.S. version of GOR, (i.e., lbs of water per lb of steam). It is not uncommon to assume each pound of steam has an average enthalpy of 1,000 British thermal units (Btu), hence:

$$P_R = \frac{lb_{H_2O}}{1,000Btu}$$

The metric version has been adopted by industry to be:

$$P_R = \frac{kg_{H_2O}}{2,326kJ}$$

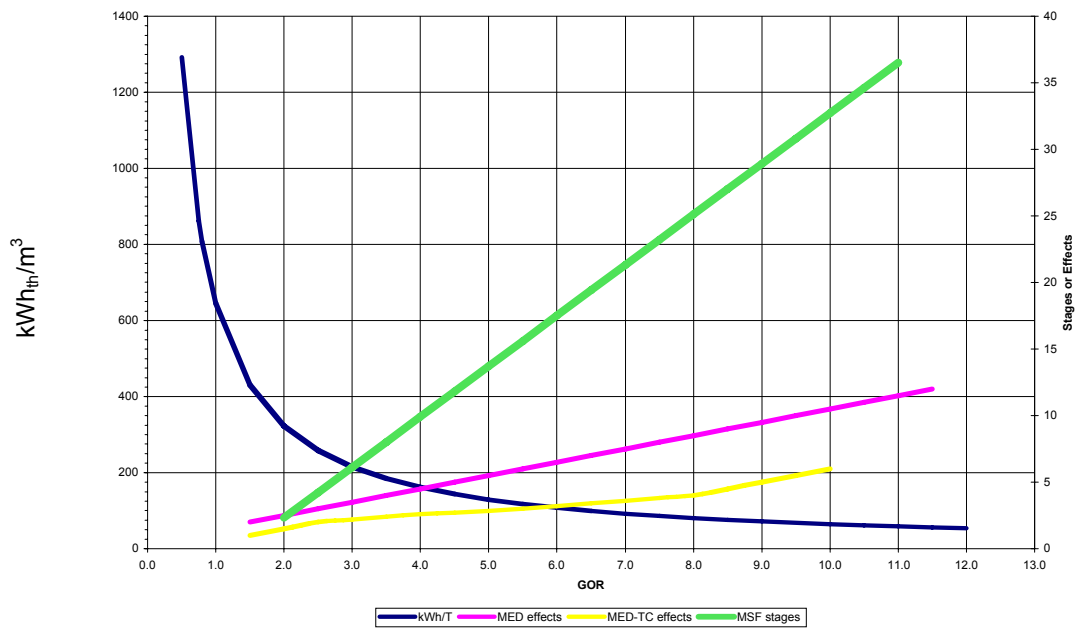

**Figure 1. Distillation Energy Consumption.**

## 3. Discussion of Findings

Desalination is becoming more widespread both domestically as well as globally, particularly as water stress increases. Most of the newer desalting processes, such as reverse osmosis (RO), are membrane-based. Reverse osmosis has gained wide acceptance and is considered to be energy efficient. It is well known that more energy is required to boil and distill salt water than to operate a hyper-filtration RO process.

### 3.1 Minimum Energy of Separation

All desalination processes have the same target for the minimum amount of energy required to separate salt from water; it is defined by the laws of physics. For separating salt from seawater, the target is approximately 0.7 kilowatthour (electric) per cubic meter (kWh/m<sup>3</sup>)<sup>1</sup>; this value considers some practical factors, but assumes an ideal process – a theoretical concept.

Boiling water requires about 650 kWh/m<sup>3</sup>, which is commonly expressed as 1,000 British thermal units per pound (Btu/lb). This is the amount of energy required to boil water that is already heated to the point where it is about to boil. RO, on the other hand has demonstrated it can desalt seawater using as little as 1.6 kWh/m<sup>3</sup>.<sup>2</sup> Why consider a distillation process requiring energy hundreds of times higher than the theoretical minimum in favor of RO, which is approaching two times the theoretical minimum? The question is very simple, but the answer requires the consideration of some practical issues. First, it is important to recognize some key points.

- RO is an efficient process, but for seawater, the electrical energy consumption is more typically 2.25 to 2.75 kWh/m<sup>3</sup>.
- RO produces a permeate that contains slightly less than 1 percent (%) of the salt found in the saline water. For seawater, the permeate is typically 300 milligrams per liter (mg/L) total dissolved solids (TDS); if better quality permeate is required, a second stage (second pass) of RO treatment is typically incorporated.
- Several different types of distillation processes are used for desalination, but they all generally produce distillate (product water) between 5 and 25 mg/L TDS and can achieve 2 mg/L TDS or better with feedwater as saline as seawater.
- Distillers generally require 0.8 to 4.5 kilowatthour (electric) per cubic meter (kWh/m<sup>3</sup>) of electrical energy for process pumps, and an

---

<sup>1</sup> There are many references that explain this theoretical calculation, including Speigler and El Sayed, ISBN086689-034-3; Chapter 3.

<sup>2</sup> Demonstrated by the Affordable Desalination Coalition <http://www.affordabledesal.com>.

additional 40 to 1,200 kilowatt-hour (thermal) per cubic meter ( $\text{kWh}_{\text{th}}/\text{m}^3$ ) of thermal energy to operate the process.<sup>3</sup>

These process differences are identified in figure 2. This figure shows the generic similarity between thermal and membrane processes as separation techniques highlighting the fundamental differences. Energy is a primary concern for any desalination project, even with the highly efficient RO process. Recently projects in Perth and Sydney, Australia, have elected to utilize 100% renewable energy for their RO plants by contracting for power from remote wind farms. An exciting possibility exists to enhance the overall carbon footprint by utilizing thermal desalination.

### 3.2 Cogeneration

Distillation processes include multi-stage flash (MSF), multiple-effect distillation (MED), and mechanical or thermal vapor compression (MVC, TVC), and the facilities are often referred to as distillers, evaporators, or simply thermal desalination units.

Some distillation desalination processes use a relatively small quantity of electricity. These are primarily the thin-film processes such as MED, which consume between 0.8 and 1.25  $\text{kWh}_e/\text{m}^3$ . If these processes are combined with existing sources of unused heat, then the overall carbon footprint will be lower than using RO. Even if electricity is generated by 100% renewable energy, using a distiller in this manner means that more renewable energy can be sent to the grid to reduce fossil fuel generation elsewhere.

As shown in figure 3, by combining a source of waste heat with a thin-film distiller, the value of prime energy required to drive the process is closer to the minimum energy of separation than any other desalting technique. Figure 3 is a theoretical configuration for discussion purposes, but it highlights why distillation may not only be competitive with RO but may also have a lower carbon footprint.

Distillation techniques have long been popular in the countries of the GCC<sup>4</sup> in the Arabian Peninsula. The seas around the GCC countries have large seasonal variations in temperature and salinity along with high organic loads that, until recently, proved challenging for RO desalination. Therefore, MSF has been the backbone of water production in the GCC countries.

---

<sup>3</sup> An explanation as to why distillers have a wide range of thermal energy requirements is provided in the section titled “Maximum Thermal Efficiency Not Always Justified.”

<sup>4</sup> Gulf Cooperation Council; Bahrain, Kuwait, Oman, Qatar, Saudi Arabia and the United Arab Emirates.

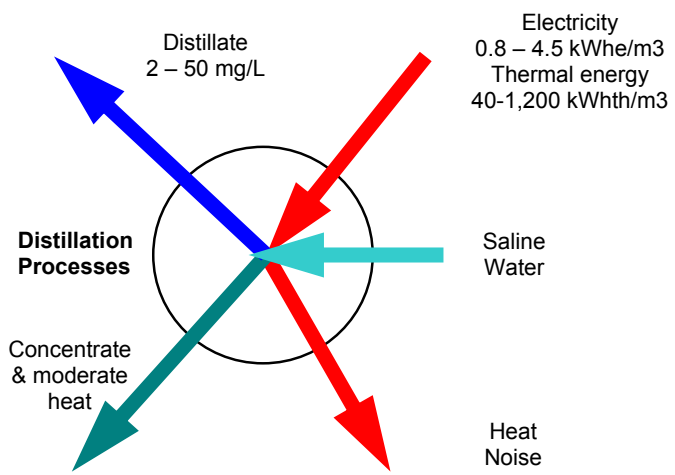
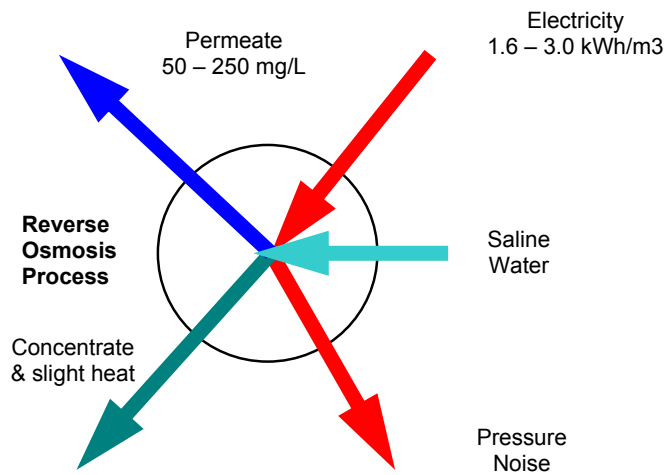
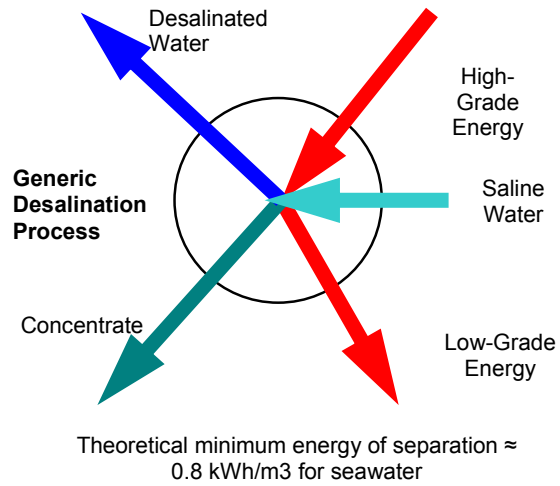

**Figure 2. Block Diagrams for Generic Desalination of Seawater ( $\approx$ 35,000 mg/L TDS).**



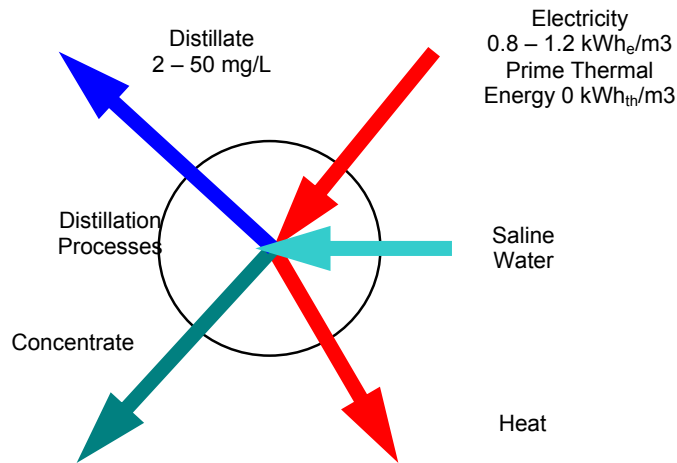

**Figure 3. Block Diagram for Waste Heat Thermal Desalination.**

There are several ways to generate power, all of which involve a minimum of one thermodynamic cycle.<sup>5</sup> Reciprocating engine-driven generators utilize the Otto or diesel-engine cycles. Steam turbine generators operate on the Rankine cycle, while gas turbines follow the Brayton cycle. Each of these cycles is a well understood ideal thermodynamic process; however, all equipment and facilities based on these cycles are far from ideal; they have unavoidable thermodynamic losses that represent heat which can potentially be recovered for further use. In many cases, heat MUST be removed from the cycle, which means equipment must be installed to keep the process cooled.

The GCC countries usually combine their desalination and power facilities in such a manner that the heat remaining after power generation is directed to the MSF units. MSF is a robust process relatively insensitive to the rugged and seasonally varied sea conditions. In chemical engineering terminology, MSF is a forced-circulation rather than thin-film process, with the result that it consumes a similar quantity of electricity as RO.

Examples of two such dual-purpose cogeneration facilities are Taweelah and Shuweihat, which are profiled in appendices A and B, respectively. These projects were chosen because Taweelah is currently the largest facility in the world, while Shuweihat has the largest individual machines (for MSF or any other process). If these plants are base-loaded and the heat is truly “waste,” then there is little or no net-energy footprint between RO and MSF. This is, of course, a simplification; the processes have different capital and operating costs, are robust to different degrees, and produce water of slightly different qualities. Perhaps more importantly, the plants are not always base loaded; if insufficient waste heat is provided from the powerplant’s turbine, then either

<sup>5</sup> A thermodynamic cycle is a series of processes which returns a system to its initial state. The series of processes can be repeated the most commonly known being the Otto cycle which repeats every four revolutions, or strokes, of a gasoline engine.

water must be taken from storage or auxiliary heat must be provided. Auxiliary heat is usually obtained by operating fuel burners installed after the gas turbine exhaust which is inefficient and expensive.

For many years the efficiency of these large distillers has been defined not by what distillation technology can achieve but by the normal demand for water and nominal quantity of heat available. The quantity of heat available depends upon the type of power generation utilized on the project.

The facilities shown in figures 4 and 5 could both be configured to generate a given quantity of electricity, say 500 megawatts (MW). Clearly, when all the electricity is generated in a steam turbine (figure 4), there is a greater quantity of steam available than when part of the power is produced by a gas turbine (figure 5). If identical efficiency distillers are used, then a different quantity of water will be produced in either case. Numerous power generation configurations have been developed, and over the years, some ratios have become rules of thumb. Usually expressed as million Imperial gallons per day (MIGD)<sup>6</sup> per installed MW, the ratios are shown in tables 1 and 2.

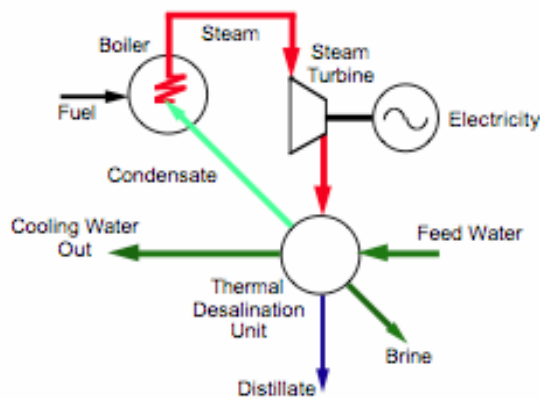

Figure 4. Power Generation Utilizing Steam Turbine.

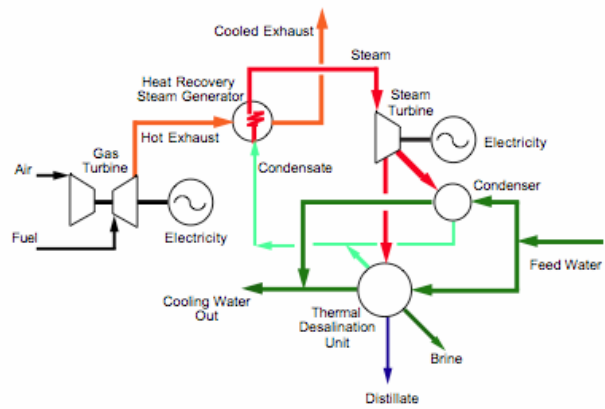

Figure 5. Power Generation Utilizing Combined Cycle.

Table 1. Power-to-Water Ratio (MSF)

Power generating configuration	MW/MIGD	MW/ (1,000 m <sup>3</sup> /d)
Back-pressure steam turbine (MSF)	5	1.1
Extraction steam turbine (MSF)	10	2.2
Gas turbine (HRSG-MSF)	8	1.76
Combined cycle back pressure turbine (MSF)	16	3.52
Combined cycle condensing turbine (MSF)	19	4.18

m<sup>3</sup>/d = cubic meters per day.

<sup>6</sup> Million Imperial gallons per day, where an Imperial gallon  $\approx$  1.2 times larger than a U.S. gallon.

**Table 2. Power-to-Water Ratio (MED)**

<b>Power generating configuration</b>	<b>MW/MIGD</b>	<b>MW/ (1,000 m<sup>3</sup>/d)</b>
Back-pressure steam turbine (MED)	3.5	0.77
Extraction steam turbine (MED)	7	1.54
Gas turbine heat recovery steam generator (HRSG-MED)	6	1.32
Combined cycle back pressure turbine (MED)	10	2.2
Combined cycle condensing turbine (MED)	12	2.64

m<sup>3</sup>/d = cubic meters per day.

With the backdrop of tough and variable seawater conditions and the proven reliability of distillers, one of the above configurations continues to be selected for most of the seawater desalination in the GCC. Which configuration is selected depends upon many factors, most of which are not directly related to desalination at all. The main water consideration is simply identifying the total demand for water. Other factors, such as the total power production and fuel available for the generation process, are what really determine what configurations are possible, practical, and ultimately are selected.

MED systems also have lower investment costs than MSF plants, which means that as RO systems are proven reliable, there is a trend away from MSF toward both MED and RO, and sometimes in hybrid configurations.<sup>7</sup>

Prior to RO being accepted as a reliable and economically viable alternative, the GCC planners were forced to face the limits placed on them by the above configurations. Water demand is quite constant throughout the year, while power demand peaks daily but also has severe summer spikes.

### **3.3 Maximum Thermal Efficiency Not Always Justified**

Strangely, there has been little or no consideration of different distiller efficiencies (as measured by the GOR) for this particular application. This is partly because of the large size of the MSF and MED distillers used in the GCC countries, with maximum sizes of 70,000 cubic meters per day (m<sup>3</sup>/d) (18.5 million gallons per day [MGD]) and 36,000 m<sup>3</sup>/d (9.5 MGD), respectively, but also because of a lack of knowledge shared between large municipal and smaller industrial thermal desalters.

<sup>7</sup> The term hybrid in desalination terminology most frequently refers to a facility that has both thermal and membrane desalination processes operating in parallel. There can be economic advantages to the use of heat, and electricity can also provide operational flexibility based on energy type availability and the potential for blended potable water quality (e.g., distillate and permeate). Detailed discussions of the various types of desalination hybrids can be found in the Middle East Desalination Research Center's reports 97-AS-008a and 97-AS-008b, which can be downloaded from <http://www.medrc.org>.

Thermal desalination is different from other industrial types of distillation or evaporation in two respects. The first difference is size; these are physically large machines often more than 100 meters (m) long, weighing thousands of metric tons, and producing 75,000 m<sup>3</sup>/d (20 MGD) of water from a single unit, with a facility often incorporating six or more identical units operating side by side. One phase of a thermal desalination project can easily exceed \$500 million (2007). A second difference is their thermal efficiency. Most evaporators used in various chemical and process industries are less sophisticated (than desalination distillers), and they typically operate with much smaller volumes of higher value fluids. Due to the smaller volumes, and the higher value of the fluids evaporated, most industrial distillers operate with GORs between 1 and 4:1.

Industrial thermal desalination systems are often coupled with waste heat sources and are designed with GORs in the range of 1 to 4:1, similar to other industrial stills. These desalination units may only be distinguished from their municipal relatives by their materials of construction. Larger thermal desalination systems, often referred to as “land based,” are for municipal water production in significant quantities ranging from 5,000 to 75,000 m<sup>3</sup>/d per unit. The largest plants, up to 75,000 m<sup>3</sup>/d each, are all designed with GORs in the range of 8 to 9:1 and are frequently coupled with thermoelectric power plants (as discussed above). Most of these systems are located in the GCC countries of the Arabian Peninsula. Smaller systems with unit capacities of 5,000 to 15,000 m<sup>3</sup>/d are found globally in higher energy value regions, such as the Caribbean, where GORs are in the range of 10 to 15:1 range.<sup>8,9,10</sup>

These high GOR designs are not found in other industrial distillation or evaporation applications such as sugar evaporation, caustic concentration, or petro-chemical distillations, to name a few. The two main driving factors that economically justify a high GOR design are a higher demand for additional water production and/or a higher energy value.

Thermal desalination processes can be designed (and are currently operating) with GORs ranging from less than 1 to over 15:1. One distiller can, therefore, be more than an order of magnitude more efficient than another. This is distinctly different from RO desalination designs, which have much less variability in energy consumption; all RO plants use similarly performing membranes, pumps, and energy recovery devices.

---

<sup>8</sup> Virgin Islands Power and Water Authority (VI-WAPA) has several MED units with a minimum GOR of 8 and maximum of 10, operating since 1981. Aruba's Water en Energiebedrijf (WEB), the local water and power utility, has six MSF units with a GOR of 11:1. Saint-Martin's Union Caraïbes de Desallement d'eau de Mer (UCDEM) has several highly efficient MED units, one of which has a GOR exceeding 15:1.

<sup>9</sup> Dual-purpose desalination plant: high-efficiency multi-effect evaporator operating with a turbine for power production; Temstet and Laborie, IDA World Congress, Abu Dhabi 1995.

<sup>10</sup> Case Study of Operating Experience of 9 Low Temperature MED plants in the U.S. Virgin Islands; Elovic & Willocks, IDA World Congress, San Diego 1999.

Distillers can be designed with vastly different quantities of stages (effects or other process sections), each of which operate at different temperatures and degrees of vacuum. The number of these process sections that are employed and how the thermal energy cascades between them determines both the GOR and the capital cost of the equipment. A higher GOR is obtained by having more process sections, which leads to a higher capital cost and is, therefore, only justified by appropriate energy costs. The total water cost is optimized when the tradeoff between operating costs (of which energy is a large portion) and capital costs is minimized, as shown in figure 6.

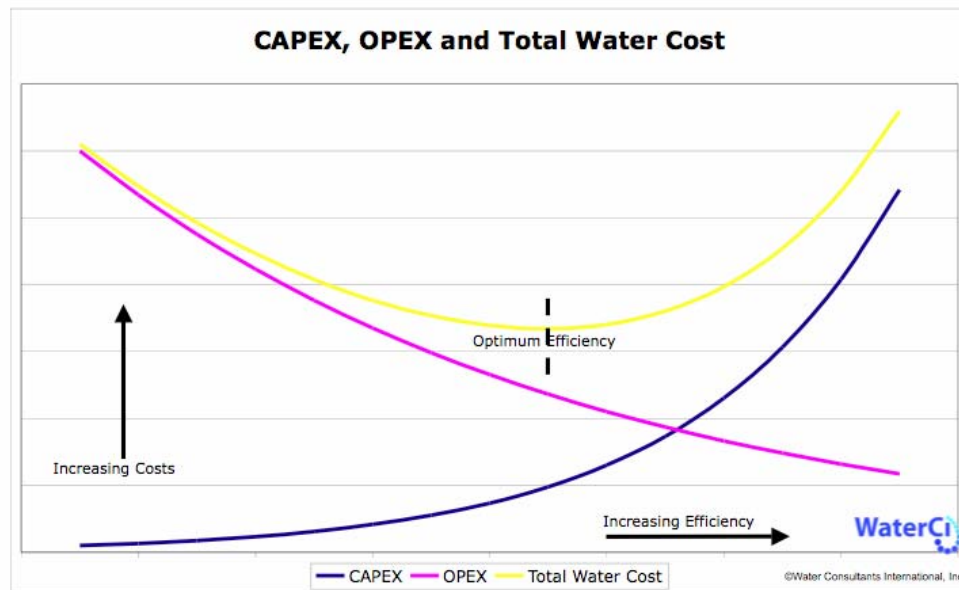

**Figure 6. Distiller GOR Versus Capital Expenditures (CAPEX) and Operating Expenditures (OPEX).**

Consider a methanol production facility that has copious quantities of waste heat and a limited demand for distilled water. There are several such facilities around the world which have optimized their designs with GORs in the range of 3 to 4:1.<sup>11</sup> Such a design reduces the capital cost but can also make it economical to utilize expensive (and very reliable) materials of construction, which would be cost-prohibitive with a larger, more efficient, high-GOR design.

<sup>11</sup> The world's largest methanol facility at Cape Horn, Punta Arenas, Chile has five MSF units all designed with a GOR of around 4:1 to utilize the waste heat available and to cool the methanol production facility while also producing high purity distilled water. Atlantic Methanol (AMPCO) in Equatorial Guinea and Titan Methanol in Trinidad are two other examples of low-GOR designs matching heat available with facility demand for high purity distillate.

Conversely, consider a cogeneration project in the U.S. Virgin Islands where potable water is required in multi-million gallon quantities. Even when waste heat from power generation is used, this energy still has a relatively high value due to the prevailing local fuel cost. Water also has a higher economic value in this location, so the distillation plants used here and elsewhere in the Caribbean have a GOR of 10:1.

Theoretically, distillers can have GORs of up to 20:1, but this must be supported by project specific economics. To date, the author is not aware of any desalination distillers that have operated with GORs over 16:1.

### 3.4 Waste Heat

Despite the potential to design for a wide range of GORs, it is not widely known within the desalination industry, particularly among those who are only proponents and experts in the use of RO and other membrane processes. The paradox is that a system designed to be inefficient with its use of waste heat may be both economically and environmentally sound. In fact, when the source of heat comes from an industrial process that must always be cooled, then the distiller must never exceed a minimum efficiency; to utilize less heat would not cool the industrial process. Frequently, comparisons are made between the operating and capital costs of distillers versus RO systems, and invariably these are based on the more expensive installations (plants with GORs greater than 8:1), not the lower capital cost designs specifically configured for waste heat applications.

One of the best examples of a waste heat thermal desalination application is one that uses the heat of dilution that naturally occurs when fresh water is added to a concentrated acid.<sup>12</sup> This heat can be used to produce the fresh water required for the dilution using seawater as the feedwater, providing a solution for an arid industrial location. This case has been specifically studied by several desalination contractors and at least one U.S. Trade and Development Agency (TDA) study for the phosphate mining industry that is the industrial backbone of Morocco. The TDA study for OCP Morocco considered several different options for recovering heat that could produce steam for power and/or water production or hot water from the exothermic heat of dilution, which would drive the desalination process.<sup>13</sup>

The studied project in Morocco has not been developed but a similar project at a large Australian nickel mine, Ravensthorpe, is now in operation in a very arid region. Two 3,300 m<sup>3</sup>/d MED units provide all the facility fresh water requirements using the heat of dilution from an inhouse acid plant (while it is

---

<sup>12</sup> When a solvent is added to make a solution more dilute, the reaction can release heat. For some solutions such as sulfuric acid, the heat released when it is diluted is substantial.

<sup>13</sup><https://www.ustda.gov/library/NTISInfo.cfm?cfid=319052&cftoken=60637343&holdno=200110025A01>.

in operation) or alternatively using steam. The desalination system for Ravensthorpe was provided by Veolia Water Systems.

Another example of a simpler waste heat and process cooling type application is the production of 7,500 m<sup>3</sup>/d of distilled water for an Amoco-Mitsui joint venture producing purified terephthalic acid (PTA) facility in Indonesia. The distiller was an MSF unit built by Aqua-Chem, Milwaukee, Wisconsin (now part of Aquatech International), which took heat from a process condensation tower. It was critical for PTA production that the MSF units always accepted the quantity of heat being rejected from the condensation tower.

The AVR solid waste incinerator in Rotterdam (Netherlands) burns almost 400,000 metric tons of waste per year (figure 7). Part of the heat from the incinerator also desalinates 24,000 m<sup>3</sup>/d of brackish groundwater. AVR uses two 12,000 m<sup>3</sup>/d desalination units based on the MED process, which were provided by VA-Tech WABAG.

### **3.5 Cogeneration in Practice**

Cogeneration in desalination terminology creates an expectation for a facility that will produce large, balanced quantities of power and water. There are few, if any, desalination cogeneration locations where anything other than power is cogenerated. In many cases, most if not all, of the steam that expands in a turbine to produce electricity is then condensed in a desalination process. Power and water cogeneration facilities, such as the one shown in figure 8 at Fujairah UAE, are typically very large, with power generation in excess of 500 MW and water production over 550,000 m<sup>3</sup>/d (145 MGD).

Cogeneration may not have the same definition outside the desalination industry. Several combined heat and power projects distribute heat for building heating or other purposes. A few projects are considered tri-generation because some of the heat may be used (seasonally) to provide central cooling via the use of absorption chillers. Most of these co- and tri-generation projects are smaller, usually linked to decentralized or captive power production rather than the utility-scale projects normally found in the desalination industry.

Non-desalination cogeneration facilities typically involve a relatively small portion of steam, or heat, being used for anything other than the prime generation (which is usually electricity). Typical U.S. projects would involve 10% of the powerplant heat source being usefully utilized to cogenerate something other than electricity (often it may be district heating or cooling via absorption chillers).



**Figure 7. AVR Rotterdam Waste Incinerator  
2 x 12,000 m<sup>3</sup>/d/ MED Units (Photo Courtesy Magy  
Al-Allawy).**



**Figure 8. Fujairah, UAE Hybrid Cogeneration –  
650 MW 300,000 m<sup>3</sup>/d MSF and 170,000 m<sup>3</sup>/d  
SWRO.**



### 3.6 U.S. Power and Cogeneration

The U.S. power and cogeneration industry has a specific definition of cogeneration that is in line with the common usage of the term associated with desalination projects. It also is in a state of flux, with key changes to the cogeneration regulations happening in 2006 and 2007.

Understanding the national power market and regulations would seem to be a reasonable goal to allow comparison with international cogeneration projects. While it may be a reasonable goal, it is far from simple, and many within the energy sector have already attempted to align the two with limited success.

It is probably best to consider the simpler reference point for international markets which have (desal) cogeneration. In most cases, the market started with 100% public sector involvement. Government agencies, such as Aruba's WEB or Abu Dhabi's Water and Electricity Department (WED), owned and operated their facilities and produced water and electricity for delivery via government-owned distribution networks. WED no longer exists; it was split into several groups to allow for privatization. Abu Dhabi Water and Electricity Authority (ADWEA) licenses the private owner/operators who purchased the old WED facilities and who now competitively bid to build new capacity. The Regulatory Services Bureau (RSB) sets quality and performance standards and ensures the wholesale market functions properly. Saudi Arabia's power and water market is similarly being privatized, and others in the region have already done so, all following legal and regulatory structures similar to Abu Dhabi's.

The U.S. electricity market is complex, and in the opinion of some, is a "half complete restructuring of electricity markets."<sup>14</sup> Prior to the Public Utility Regulatory Policy Act (PURPA) of 1978, electricity generation and distribution was a monopolistic and franchised market. PURPA required the utility generators to purchase power from smaller independent generators and encouraged these facilities to use newer more efficient generation and cogeneration techniques. By meeting some simple rules where there was "presumptively useful" use of thermal energy, a project would become a Qualifying Facility (QF), removing the need for compliance and regulatory issues/procedures that public utilities have to face. Apparently Congress was aware that this was an experiment with a partially competitive and incentivized market.

The QF facilities could force the public utility to buy power at attractive rates based on the utility's "avoided cost." While the term "avoided cost" may be simple for economists, and perhaps accountants, it has proven difficult to

---

<sup>14</sup> Electricity Market Design and Structure: Working Paper on Standardized Transmission Service and Wholesale Electric Market Design; William Hogan, docket RM01-12-000 submitted to FERC April 10, 2002.

apply to the PURPA regulation, leading to disputes and generally adding to the confusion. The regulatory, operating, and tax benefits of being a QF facility added up to one benefit, a lower cost of power. The burden required to achieve and retain QF status was simply that the waste heat from power generation was used “purposefully.” In addition, a public utility could not own and operate a QF facility, since the *raison d’être* for QFs was to encourage competition and efficiency gains at public utilities.

A typical QF facility is a small, between 5 and 25 MW, combined-cycle facility.<sup>15</sup> A common configuration has a natural gas combustion turbine, literally a modified jet engine, connected to and spinning an electric generator. The hot gas leaving the engine passes through a heat recovery steam generator (HRSG) which cools the gas and uses the heat to make steam. The steam from the HRSG passes through and rotates a steam turbine which is connected to a second electric generator. Gas passing through a jet engine follows the thermodynamic rules defined by the Brayton cycle, while the steam in its turbine behaves within the confines of the Rankine cycle; when these two systems are used together, the power facility is known as “combined cycle.” Some of the steam from the QF facility can be directed to a third party facility where it is “presumptively useful,” and then usually returned as condensate for reuse in the Rankine cycle. Examples of this type of QF facility include steam provided for fruit juice concentration factories or for digesters in pulping mills, facilities that may also have purchased some or all of the electricity generated by the QF.

For some time, FERC and the public utilities have had concerns about some aspects of PURPA and QFs, including the potential for sham projects taking liberty with the guideline for “presumptively useful” thermal energy.<sup>16</sup> The author is not aware of projects that were envisaged as shams from the beginning, although they may exist, but the author can point out projects that later developed questionable attributes. These developments may be little more than unintended but inevitable consequences of PURPA QF regulations. As an example, consider a QF facility providing 25% of its steam to a third party (a fruit juice concentrator), which, after many years, suddenly ceases operation. The QF facility then decides to use the steam to cogenerate distilled water but is immediately faced with several practical problems. The QF facility may have been designed to include equipment that can condense 100% of its steam production (for cases when the third party was off-line) but

---

<sup>15</sup> Fossil-fired QF facilities cannot be larger than 30 MW.

<sup>16</sup> <http://energylegalblog.com/archive/2006/02/07/177.aspx> Energy Legal Blog: Rule Narrows Universe of Qualifying Facilities, Widens Ownership. FERC has recently tried to update PURPA and avoid “sham” QF facilities. The Energy Policy Act of 2005 provided a new PURPA Section 210 which updates the original 1978 QF requirements in two ways which impact this report. First public utilities can now challenge the usefulness of the thermal energy being used for cogeneration but perhaps more practically public utilities can now own QFs. More than the author have asked how long it will be until public utilities own and close most of the QF facilities and Congress’s 30-year experiment will be over.

it was not configured to incorporate and cool a distiller. When a QF loses its third-party thermal host, there are immediate concerns that the same percentage of thermal energy must continue to be used for cogeneration or the facility will no longer meet QF requirements – with subsequent loss of its cost-saving exemptions and guaranteed purchase of power by a public utility. Also, the QF facility never had a sales or marketing strategy for water (or heat) in its business plan. The result of this combination of parameters is that the QF has a sudden desire for a distiller that will condense as much steam as possible, yet produce a limited amount of water. The QF did not know how to sell and did not have the infrastructure to handle large quantities of water production.

The author has visited QF facilities which had juice concentration factories or pulp mills as their third-party thermal host. When the third parties ceased operation (through bankruptcy or otherwise) the QF facilities had few options in their quest for a new “steam host.” The PURPA QF projects that currently have desalination cogeneration facilities are diametrically opposite to the desalination industry’s view of a cogeneration plant. The PURPA cogeneration facilities incorporate very-low-GOR distillers; they are encouraged by circumstances to make as little water as possible, as inefficiently as possible. Re-distilling distilled water was at least considered on one project the author is aware of, which involved consuming more thermal energy and reducing the quantity of distilled water produced.

Prior to FERC’s partial deregulation of the power industry in 1978, it was clear that utilities were responsible for spinning reserve capacity and distribution of power to their consumers. The country’s power distribution grid had minimal interconnections between regional grids. Since then, competition and efficiency improvements on the generation side and greater access for independent generators to the transmission grid have developed, but other complexities have arisen. Who or where is the spinning reserve capacity? How is access to transmission grids prioritized? When loads increase on a transmission line, how are the increased losses assigned to the multiple generating entities? To manage the power transmission market, regional transmission organizations (RTOs) were created (RTOs are also known as Independent Systems Operators or ISOs). Each RTO has a slightly different structure and objectives that consider the needs of the region. Some States have greater influence than others within an RTO, and some States must participate in several RTOs. Some areas may not be served by an ISO or an RTO. Efforts to streamline and simplify this market continue but slowly. As recently as December 31, 2006, efforts to make a joint and common market between the Midwest and East Coast RTO were challenged by some generators because it would still not make a single common market (Midwest ISO & PJM).

The bottom line is that the U.S. power market is complex and not yet a single open market. The distribution grids and RTOs are not ideal, but it is now

possible for electricity to be “wheeled” in both the commercial and residential markets.<sup>17</sup> Charges for wheeling can vary depending upon the congestion on the transmission system at any given time, just as the base cost per kW varies with spot energy markets.

This makes for a complex situation, with various RTOs operating regional markets and utilities trying to compete for the most stable and maximum base load within the markets they serve. Independent power producers and QF facilities are often at odds with the RTO and utilities about the level of access the former have to the power market.

The situation is even more complicated if activities that are not core to power generation are to be added to the mix, such as water production. Even though overall thermodynamic efficiency can be improved by cogeneration, the United States does not have a distributed or competitive market for water. Cogeneration of power and water in other geographic regions all have a common theme—single offtakers for power and water, e.g., U.S. Virgin Islands **Power and Water Authority**, **Water en Energieberijf Aruba**, or Abu Dhabi **Water and Electricity Authority**.

The Energy Policy Act of 1992 sought to improve efficiencies in several ways, including integrated resource planning. The possibility of integrating power and water production never seemed to merit consideration. This is especially troubling when so much energy is consumed in the transportation of water within the Nation, particularly to meet the needs of the arid Southwest. Water- and energy-strapped southern California highlights the situation—transporting water around the State consumes one-fifth of the State’s total consumption of energy.<sup>18</sup> While renewable and lower greenhouse gas methods of generating electricity are hotly pursued, the impact of transporting water from one watershed to another is ignored. California’s energy consumption is of a similar order of magnitude to current (and steadily improving) seawater desalination. California’s movement of water creates environmental impacts such as drying up the Colorado River delta and affecting fish in key coastal rivers. Thousands of miles of major water transfer piping and canals are also vulnerable to earthquake damage. Many of these issues, including greenhouse emissions, could be mitigated by the local production of distilled water utilizing waste heat. There are no open markets or regional transmission organizations for water. Water transportation is complex, with multiple layers of public-sector wholesale agencies trading water and distributing allocations. There is an existing power and influence

---

<sup>17</sup> Wheeling is the ability of a power producer to deliver power to a consumer (residential or commercial) over distribution grids and networks that are owned and operated by others. It is similar to the ability of the consumer to choose telephone service from Company B even though Company A still owns and operates the telephone line connected to his home.

<sup>18</sup> This is well summarized in *Water Desalination Report Volume 43, Number 24*, June 25, 2007, which includes a comparison of various desalination, recycling, and water transportation energy consumption values per unit volume of water.

structure associated with the current method of water distribution that is resistant to drought-proof water supplies such as desalination. Introducing new water supplies would erode the power these water wholesale agencies have over the local water authorities who provide water within communities. New local supplies from brackish groundwater, seawater, or other saline sources provide communities with self reliance and control over their own pace of development, rather than being directed from remote and partially unaccountable water wholesalers.

### **3.7 Public-Owned Treatment Works or Long-Term Purchase of Water?**

Access to water consumers has been a significant issue for the potential development of desalination of any type within the Nation. Traditional water treatment facilities are largely publicly owned, and new projects typically follow a design/bid/build (DBB) approach. In many jurisdictions, DBB is mandated by law, resulting in municipal engineers developing generic designs that can then be bid by many contractors and then built by the lowest bidder. Advanced water treatment processes like desalination may involve competing proprietary treatment processes or at least significant variations in either the design or operation schemes offered by bidders.

Over the past 20 to 30 years, the international desalination market has shifted away from the DBB or equipment supply model to focus on the supply of water rather than equipment. Water Purchase Agreements (WPAs) for 20 to 30 years are now common and are often referred to by various acronyms that explain some aspects of the contract, for example:

DBOO – design/build/own/operate

DBOOT – design/build/own/operate/transfer<sup>19</sup>

These schemes remove the need for investment and ownership from the public sector, but there are options for the public to take over ownership after a predefined period of successful operation (the T in DBOOT). Many political issues have arisen regarding the involvement of the private sector, but these have been solved in many other jurisdictions; a key point to remember is that existing procurement techniques such as DBB are hampering the deployment of desalination (and other advanced technologies). The focus of WPA project evaluations are the proposed future cost of water production, which includes guarantees on power, consumable and, often, manpower cost increases over the life of the contract. Efficiency is usually guaranteed, while energy costs are passed through to consumers at current rates (as is done today with electricity bills).

---

<sup>19</sup> Transfer means assignment of ownership.

The ability to purchase desalinated water rather than build and own water treatment facilities has allowed some communities to consider advanced water treatment. Desalination and similar advanced processes are more capital-intensive and arguably more complex than traditional treatment works, which are largely unchanged in decades. It has been stated that the Tampa Bay Desalination Project would never have been initiated<sup>20</sup> if it had not been based on an alternative project delivery model similar to WPA/DBOOT. Bankruptcy of the main contractor (for reasons unrelated to the desalination project) led to a complex commercial and legal situation that opened the door for technical compromises, resulting in a delayed and problematic project. Nonetheless, a major barrier to considering this type of project is the entrenched DBB project delivery method. Most, if not all, desalination projects being considered in California and Texas all appear to be based on some form of public-private partnership similar to a WPA or DBOOT arrangement.

All these projects, however, rely upon the public entity (the offtaker) either initiating the need to utilize alternative water supplies or being open to private sector approaches. There are currently limited channels that a private sector developer can take to get the water he produces by desalination to third parties. “Wheeling” water through the existing water transportation infrastructure is difficult and has not been deregulated in any way. This obstacle is difficult enough for a stand-alone RO facility to overcome, but is more complex for a project that may also be integrated with power production or waste heat availability. Just because cogeneration introduces more variables (than RO) does not mean that the potential environmental and economic savings of integrated thermal desalination should not be considered or even encouraged.

There are economic and political forces at work in the Southwest United States as communities, farmers, and industries compete for the shrinking supply of water. Recycling, reuse, and conservation are encouraged, along with consideration of desalination. What is missing from this is consideration or encouragement to cut back on the use of freshwater and to investigate potential saline sources along with waste heat for desalination. Industries that have waste heat should be encouraged to use that heat to meet their water supply needs or to assess the potential for supplying water to their neighboring communities.

In many places, such as Abu Dhabi, the privatization of power and water utilities has shifted to WPA and privatization, but retains strong public sector involvement. The bidder that is selected as having the best design and proposed water rates (known internationally as tariffs) creates a special purpose company (SPC) to build, own, and operate the facility over the life of the contract. The public sector offtaker normally stipulates the range of debt-to-equity considered acceptable and also may take an equity interest in the SPC. This arrangement creates a risk sharing between the public and

---

<sup>20</sup> Personal discussions between the author and Tampa Bay Water staff.

private sectors and ensures that any future cost savings are also shared. The Abu Dhabi model that is largely being replicated in many other countries was developed by U.S.-based legal teams.<sup>21</sup>

Channels to market water produced by cogeneration are a key factor whether this is done on a large scale (as in the GCC) or on a smaller industrial scale. Currently, an industrial facility that has waste heat but little or no demand for water has no incentive to utilize the heat or an outlet for water it could produce. This can be the case even when the industry is in an arid community that could use the water. As has been previously discussed, using waste heat and thermal desalination to produce water could provide a community with the lowest carbon footprint path toward a new water supply.

### 3.8 Heat Rate, Exergy, and Cogeneration Policy

The Energy Policy Act of 2005 does not specifically address cogeneration but did require FERC to issue a new rule for QF criteria in 18 Code of Federal Regulations (CFR) 292.205. This rule clarifies that 50% of the aggregate electrical, thermal, and mechanical output of the cogeneration facility on an average annual basis must be used in a “productive and beneficial manner.” Perhaps more importantly, this CFR defines efficiency limits that generally must be met for both baseload and peaking (or topping) operation. The efficiency is not explicitly defined but is likely a fuel-to-electric line efficiency of around 45%.

Many exergistic analyses of power and water cogeneration exist, most of which were aimed at putting a rigorous scientific basis on the allocation of shared costs between power and water production (and therefore between the costs of power and water); see figure 9.<sup>22, 23</sup> All of these analyses show that cogeneration raises the exergistic efficiency of the production of power and water significantly, because maximum efficiency is gained by making full use of the thermal energy.

---

<sup>21</sup> Water Purchase Agreements and DBOOT contracts have been common for many years in the Caribbean, including the U.S. Virgin Islands. Other novel public-private partnerships have also been applied to desalination, including the Australian “Alliance” concept. Alliancing is an integrated project delivery model that has been shown to streamline and expedite challenging projects in several industries. See <http://www.dtf.vic.gov.au/CA25713E0002EF43/pages/asset-management---project-support-project-alliancing>.

<sup>22</sup> Energy is never lost or destroyed in a process; this statement is better known as the First Law of Thermodynamics. Exergy is the quantity of energy that is available to be used (usually productively in lay terms). Exergistic analysis apply this concept within the rules of the Second Law of Thermodynamic to measure how efficient a process is, such as converting fuel oil into electricity, water and/or useful heat.

Thermoeconomic Analysis of a Cogeneration Plant, Munoz & Valero, International Symposium on Thermodynamic Analysis and Improvement of Energy Systems, Beijing (1989).

<sup>23</sup> Thermo-economic assessment of fossil fuel fired dual purpose power/water plants; Breidenbach, Rautenbach & Tusel, *IDE Congress*, Madrid (1997).

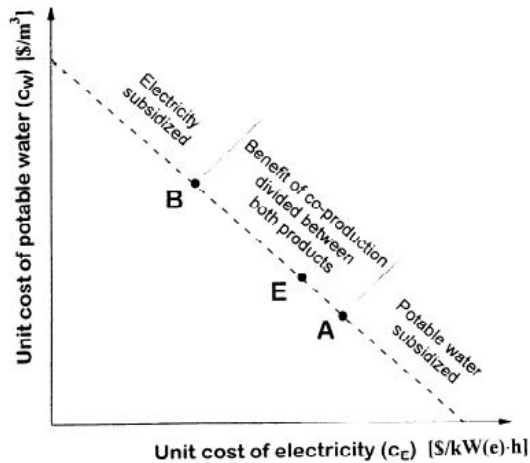

**Figure 9. Exergy Cost Allocations (From Breidenback, et al.).**

Appropriate CFR guidance could expand on the qualification criteria for both Small (18 CFR 292.204) and Cogeneration Power Plants (18 CFR 292.205) to highlight the potential positive environmental impact for cogeneration of water via thermal desalination.

The Energy Policy Act of 2005 does cover renewable power generation but does not directly or explicitly consider renewables relative to desalination. Several desalination processes utilize only electrical energy and could be easily driven by electricity generated from renewable sources. While this is more environmentally friendly than desalination driven by fossil-fueled energy, it prevents this electricity from being utilized elsewhere, perhaps mitigating an even greater potential environmental impact.

### **3.9 Carbon Footprint and Potential Use of Renewable Energy Sources**

As previously discussed, the smallest carbon footprint for seawater (or highly saline water) is achieved when waste heat is combined with thin-film evaporation processes; even if the pumping energy uses electricity from fossil fuels, the specific power consumption is lower than RO. Since this configuration uses less electricity than RO, it is also easier to power using a renewable energy source.

Renewables using geothermal and solar energy are of particular interest. Many, if not most, of these power generation schemes are based on the use of steam turbines where the steam is produced by the renewable energy source. Just like fossil-fueled steam turbine plants, these thermal facilities must condense the steam after it has rotated the turbine-generator. This is exactly where thermal desalination processes can be integrated with the power production, as shown in figure 10.



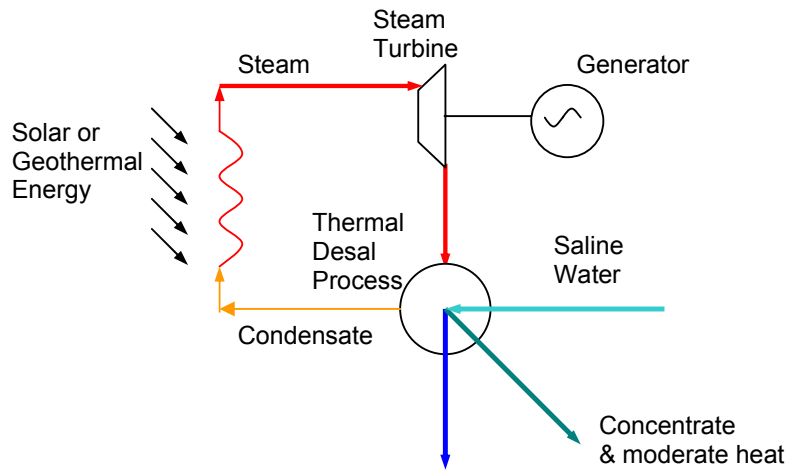

**Figure 10. Generic Diagram for Solar (or Geothermal) Power and Water Production.**

Several different ways of generating electricity using renewable heat are available; not all involve steam turbines but all of them require the engine or turbine to be cooled.<sup>24</sup> It is this cooling of the generator’s prime mover device that provides the heat for the desalination process. The desalination process must then be cooled using ambient air or a water source such as a river, lake, or the sea (via cooling towers or fin/fan heat exchangers). If the desalination process were not present, then the ambient air or water could cool the electricity generation process slightly more effectively; each unit of renewable energy would produce slightly more kW of electricity. The quantity of electricity produced from each unit of energy or fuel is known as “the heat rate.” To an electrical engineer, anything that reduces the heat rate is called a “parasitic loss.” These simplistic analyses are focused on single-purpose power generation and do not consider the benefit of cogenerating a second product – water. The entire U.S. power sector is dominated by considerations of heat rate, not exergy. Regulations and practices to determine which power plants provide electricity to the grid are based largely around heat rate. This alone is a major obstacle to development of any true desalination cogeneration in the United States.

Significant work has been done to minimize the potential reduction in heat rate, or to design thermal desalination distillers that could be retrofitted to existing powerplants. One of the ways to achieve this is to design more efficient heat transfer systems that can operate within the small temperature differential between the power plant cooling system and the environment that cools it. Such systems can obviously be integrated with renewable or waste heat sources. The Bureau of Reclamation, for example, has a thermal

<sup>24</sup> Several renewable energy electricity generation techniques do not involve heat, most notably solar photovoltaic cells and wind power.

desalination demonstration project at the Salton Sea in southern California that utilizes waste heat from a geothermal power plant owned by CalEnergy Operating Corporation (CalEnergy). The project is funded in part by a State of California Desalination Proposition 50 grant. CalEnergy currently operates 10 geothermal power plants in the Salton Sea area rated at 327 MW and has plans for an additional 185 MW. Two other geothermal power producers, Hudson Ranch Power and Iceland America Energy, also have plants each rated at 49 MW scheduled to come on line by 2010. The Known Geothermal Resource Area (KGRA) at the Salton Sea is estimated to be between 1,400 and 1,500 MW.<sup>25</sup> Overall, the State of California is estimated to have over 14,000 MW of KGRA, all of which could be developed for dual-purpose cogeneration with thermal desalination.<sup>26</sup>

California's KGRA is located, for the most part, near arid cities and adjacent to major water transportation schemes. Reclamation's thermal desalination demonstration project at the Salton Sea will produce approximately 50,000 gallons per day (gpd); however, the existing two CalEnergy geothermal power plants at the test site appear to have adequate heat to produce 10-20 MGD of water. The projected cost of water production has been estimated at \$653 per acre-foot (2008 dollars), which is comparable with coastal desalination alternatives, and does not include any credit for the lower carbon footprint of the geothermal desalination process.

Solar power projects currently being developed in the desert Southwest do not currently consider the integration of thermal desalination. As previously discussed, many solar generation schemes are based around steam turbines; after generating electricity, the steam can be usefully condensed in the thermal desalination process.

Photovoltaic (PV) cells producing electricity are well known, powering many things from calculators to homes and commercial buildings. Thermal solar generation systems come in several types but are all aimed at industrial or, more likely, utility-sized projects. Various types of thermal solar plants have been around for many years, including several in California and elsewhere. The most common and the largest of these systems use the sun's rays to heat oil or hot water. The oil or water is stored in insulated tanks, ensuring a constant supply of heat day and night and during cloudy periods, allowing electricity to be generated 24/7. This is an advantage not possible with PV, wind, or wave power because the energy produced by these processes cannot be effectively stored (there are no practical, large batteries or capacitors).

---

<sup>25</sup> DOE Data (2005), Salton Sea area: 1,500 MW, GeothermEx-CEC (2004), Salton Sea area: 1,400 MW. Other estimates, including USGS and others, have ranged from 500-3,400 MW.

<sup>26</sup> DOE Data (2005), California: 12,170 MW, Petty (1992), California: 24,750 MW. Other estimates range from a low of 3,182 MW and an average of 10,900 MW.

Solar thermal power generation combined with thermal desalination creates a system that partly overcomes the inability to store electricity; both the thermal energy and water can be stored providing operational flexibility.

In June 2007, Pacific Gas and Electric (PG&E), a major California utility, agreed to purchase 553 MW of electricity from Mojave Solar Park starting in 2011, the world's largest single solar power project.<sup>27</sup> This facility will incorporate mirrors arranged in a parabola around a trough containing water pipes and heating them to produce the steam required for turbines. The technology is patented by Solel Solar Systems and currently produces over 350 MW annually in multiple locations.

In November 2007, PG&E announced another 177 MW thermal solar project, this time using flat-reflector technology to heat overhead water pipes, thereby producing steam for the power generating turbines.<sup>28</sup> This technology is provided by Ausra.

These two projects alone represent 730 MW of renewable power that could be configured as dual-purpose power and water facilities. Depending upon the steam turbine configuration, these facilities should be able to produce in excess of 100 MGD of high-purity water for drinking, irrigation, or industrial use, taking saline or even waste water as the source. This type of thermal desalination cogeneration is in wide use overseas and has decades of proven experience.

### **3.10 Potential Application Guidance and Recommendations**

Several points should be considered when new water sources are being developed and especially when any type of desalination is being considered.

- Although not intuitively obvious, thermal processes can have the lowest carbon footprint of all seawater desalination options.
- Waste heat is abundant from industrial and commercial facilities.
- Waste heat can be coincident with the demand for water.
- It is possible that waste heat is available at one facility but demand for water is not within that facility but at another community or industrial complex.
- Thermal desalination technology is proven, and there are no technological barriers.

---

<sup>27</sup> [http://www.solel.com/files/press-pr/pge\\_solel.pdf](http://www.solel.com/files/press-pr/pge_solel.pdf).

<sup>28</sup> <http://ausra.com/news/releases/071105.html>.

- Water utility inexperience with desalination and the entrenched practices and regulations of the power industry create an institutional barrier to implementing cogeneration.

If we are to address water shortages, develop new sources, and consider environmental impacts, then we are missing the potential to turn an existing waste product (heat) into an asset that can be a catalyst for new, drought-proof clean water supplies.

Co-locating distillers along the sea coast with sources of heat and within practical distances of industrial water consumers clearly has potential.

These are some of the factors that make distillation processes generally more robust than membrane processes and make distillation more attractive in challenging locations. However, these factors can have a negative impact on distillers; their lack of sensitivity to the typical salinity range of surface and seawater means they do not have the capital or operating cost savings that RO can achieve when provided with lower salinity feedwater.

The potential for the bulk sale of water on a wheeling basis should be considered and evaluated as part of regional water supply schemes. The ability to connect appropriate water sources with distant consumers while utilizing existing water transportation infrastructure should allow greater flexibility in selecting the most appropriate water supply, while considering both technical and economic factors. In this case, economics is used in its broadest sense and includes all costs—social, environmental, and financial.

There is also potential for low-carbon-footprint cogeneration of water, along with electricity generation and other industrial facilities that can be sources of waste or low-grade heat. Integration of water production with power generation has some institutional and regulatory barriers driven by our national focus on heat rate rather than total process exergy. With this position prevalent in electricity generation, the maxim that electricity and water don't mix will prevail in the United States, despite evidence from Abu Dhabi to the U.S. Virgin Islands that they don't just mix but can flourish.

Use of waste heat may also yield potential carbon credits which can be securitized or otherwise converted into a saleable asset. The United Nations Framework Convention on Climate Change (UNFCCC) has a standard procedure through the Clean Development Mechanism (CDM) to audit and issue credits to approved projects.<sup>29</sup> The CDM is part of the implementation of the Kyoto Protocol and requires registration through national registries maintained by the signatory nations. There are other means of registering and then trading carbon credits that are not linked to the Kyoto Protocol. One of the best-known, completely commercial registry

---

<sup>29</sup> <http://cdm.unfccc.int/index.html>.

and securitization marketplaces is the Chicago Climate Exchange (CCX), although other options may also be available.<sup>30</sup>

Integration of thermal desalination to utilize heat released from other industrial processes is technically feasible but routinely encounters economic barriers. Industry must have an economic justification if it is to invest in the capital required to make use of marginal or otherwise tainted water sources. Inappropriately low water rates that encourage overuse of traditional water sources do not encourage conservation or the consideration of other sources such as desalination. Industrial processes that require cooling will ultimately discharge heat to the environment; using some of that heat for desalination means a lower, less harmful emission temperature. While this approach reduces the temperature impact on the environment, the use of desalinated water can reduce overpumping of other surface and groundwater sources.

There is no silver bullet that will solve all our water problems; however, if we continue to review cases in isolation and do not consider integration of all our resources, including those currently discarded, we will not arrive at the optimum solutions. Thermal desalination will not solve the majority of water problems that the Nation faces; however, it has a proven track record on a very large scale and should not be ignored. Simplistic reviews of the energy requirements for desalination should be discouraged, and more complete audits of the resources and needs of a community should consider the pros and cons of thermal desalination rather than relying on misguided oversimplifications.

---

<sup>30</sup> <http://www.chicagoclimatex.com/>.

## **Appendix A—Al Taweelah Desalination Facility (UAE)**

## Al Taweelah Desalination Facility—United Arab Emirates



Plant Name	A1 (Phase 1)	B	B2	A2	A1 (Phase 2)
Date commissioned	1989	1995/1997	1999/2001	2001	2002
Operating company	GTTPC	ATPC	ATPC	ECPC	GTTPC
Thermal process	MSF	MSF	MSF	MSF	MED
Units/capacity, m <sup>3</sup> /d	4@36,200	6@57,230	3@34,975	4@57,456	14@17,124
Total capacity, m <sup>3</sup> /d	144,800	343,380	104,925	229,824	239,730
Stages or effects	16	20	20	19	6
Top brine temp, °C	108	112	105	109	63
GOR	8.0	8.0	6.5	8.0	8.0
Desalination system supplier	Sidem	Fisia Italimpianti	Hitachi Zosen	Doosan	Sidem
Desal electric power, kWh/m <sup>3</sup>	4.3	4.2	4.2	3.5	1.65
Electric power production, MW	255	732	337	720	1095

Power and water capacities are nominal and may differ slightly from licensed values

The Abu Dhabi government and Abu Dhabi Water & Electricity Authority (ADWEA) have embarked on a long-term program to privatize the water and electricity sector. As part of this program, Independent Water and Power Projects (IWPP) have been introduced on a build, own, and operate (BOO) basis via joint venture arrangements between ADWEA and various international companies. In each IWPP, ADWEA is a 60% shareholder and the remaining 40% of the shares are held by international private investors. These IWPPs sell water and electricity from their production plant to the single buyer of the sector, Abu Dhabi Water & Electricity Company (ADWEC), under long-term Power and Water Purchase Agreements (PWPAs).

Three power and water production companies currently operate on the Taweelah site and currently produce 1.36 million m<sup>3</sup>/d of water and over 3,000 MW of electricity. Located on the Arabian Gulf Coast, approximately 50 kilometers (km) north of Abu Dhabi, it is operated under the direction of ADWEA and is one of the largest seawater desalination plant sites in the world. A new plant, referred to as 'B3,' is currently under construction.

### **Taweelah A1—Gulf Total Tractebel Power Company (GTTPC)**

GTTPC is a private joint stock company that operates the Taweelah A1 power generation and desalination plants with licensed capacities of 1,350 MW for electricity and 381,530 m<sup>3</sup>/d for water. The company is owned by ADWEA (60%), Total Fina Elf (20%), and Tractebel (20%) and sells its capacity and output to ADWEC.

The 2,000 IWPP was implemented under Abu Dhabi's privatization program and included the purchase of the existing Taweelah A1 power and desalination plant, which had a gross capacity of 255 MW of power and 132,626 m<sup>3</sup>/d of water. The existing A1 plant was refurbished and rehabilitated, and additional capacity was added to produce the licensed capacities.

Four existing MSF seawater desalination units originally furnished by Veolia Water's Sidem in 1989/1994 were upgraded from 32,730 m<sup>3</sup>/day to produce an additional 10.6% of product water. Sidem also served as EPC contractor to furnish 14 new MED units, each rated at 17,124 m<sup>3</sup>/day, under an accelerated 24-month delivery schedule. The stainless steel units operate at a top temperature of 63°C using 2.8 bar steam with a gain output ratio of 8.0, and have an evaluated life cycle cost 7.5% lower than a comparable MSF plant.

The first year published price of for water production at the Taweelah A1 facility is \$0.70/m<sup>3</sup>.



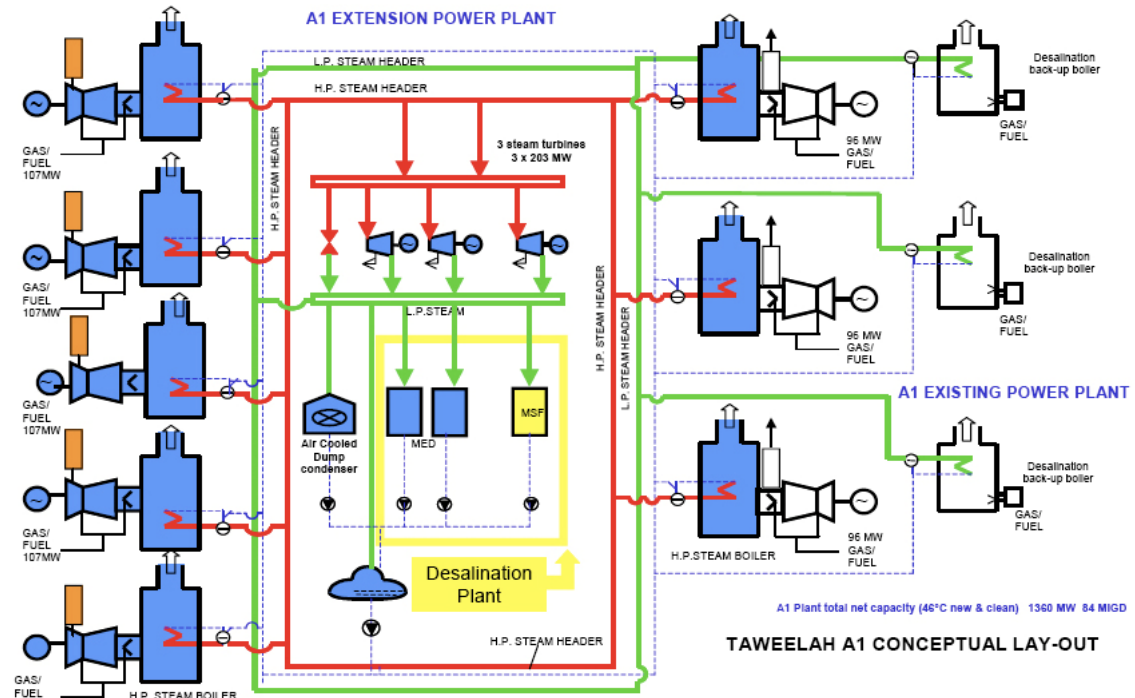

**Taweelah A1 Concept Layout.**



**Taweelah A1 MED Units.**

## **Taweelah A2—Emirates CMS Power Company (ECPC)**

ECPC is a private joint stock company established to build, own, and operate the Taweelah A2 power generation and water desalination plants with licensed capacities of 710 MW for power and 227,100 m<sup>3</sup>/d for water. The company is owned by ADWEA (60%) and CMS Generation (40%) and sells its capacity and output to ADWEC



**Taweelah A2 MSF Unit.**

Construction and commissioning of the facility was undertaken by a consortium of Siemens and Korean Heavy Industries (Hanjung) under a fixed-price turnkey agreement. The agreement provided for the training of operating and maintenance personnel, as well as for spare parts to cover an initial 6-year operating period, which has since been extended another 6 years.

The Taweelah A-2 Operating Company Limited (TA2OC), a wholly owned subsidiary of CMS Generation, provides on-going management, as well as operation and maintenance of the A-2 facility under terms of a 20-year agreement. Scheduled major maintenance of the generating equipment, inclusive of labor and parts, has been contracted to Siemens.

The current price for water produced at the A2 facility is reportedly \$0.84/m<sup>3</sup>.

## **Taweelah B—Al Taweelah Power Company (ATPC)**

ATPC is a public joint stock company and one of three power and water production companies operating on the site. It was incorporated as an independently licensed private joint stock company when the Electricity & Water Sector unbundled from Government on December 31, 1998. The Company currently remains 100% in Government ownership as a member of the Abu Dhabi Water & Electricity Authority group of companies.

ATPC operates the B and B2 power generation and water desalination stations at the Taweelah complex with a total licensed capacity of 1,075 MW and 431,492 m<sup>3</sup>/d. The company sells its capacity and output to Abu Dhabi Water & Electricity Company (ADWEC). It was constructed and commissioned in two phases – Phase 1 being of cogeneration design and Phase 2 being combined cycle.



**Taweelah B Power and Water Facility.**

Phase 1 (Plant B) was commissioned between 1995 and 1997 and consists of six identical units; each unit includes a steam boiler and condensing steam turbine generator, with steam extraction to a MSF seawater desalination distiller.

Phase 2 (Plant B2) was commissioned between 1999 and 2001 and consists of two gas turbines (operating in either simple or combined cycle), each exhausting into a heat recovery steam generator raising steam to drive a back-pressure steam turbine generator which, in turn, supplies steam to three MSF seawater desalination distillers.

Certain facilities shared with the adjacent Taweelah A-1 and Taweelah B plants are operated and maintained by the Shared Facilities Company, owned 17% by ECPC, 66% by Taweelah B, and 17% by Taweelah A-1. Taweelah B is the “operating shareholder” of the Shared Facilities Company.

### **Future Project: New Plant B Extension**

In addition to the initial Plant B and the initial Plant B2 Extension, a “New Plant B Extension” is currently being executed by a consortium of Marubeni/BTU/Powertek/JGC. The new plant is planned to include four MSF units each rated at 78,575 m<sup>3</sup>/d to be furnished by Fisia Italimpianti, and an additional 1,045 MW of power production capacity. The new plant is scheduled for commissioning in mid-2008.

**Future Project: Seawater Reverse Osmosis**

A 227,100 m<sup>3</sup>/d seawater desalination project planned to be the first major Independent Water Producer (IWP) project is expected to be established before 2010. A pilot study was conducted and an EPC contractor was selected, but the project status remains uncertain.

It is expected that an RO project company will be established with 40% share holding by the successful bidder and 60% by ADWEA. The project Company will enter into a Water Purchase Agreement (WPA) with ADWEC for supply of water to the TRANSCO system.

## **Appendix B—Shuweihat Desalination Plant (UAE)**

## Shuweihat Desalination Plant – United Arab Emirates



Date commissioned	2004
Thermal Process	MSF
Units/Capacity	6 @ 75,700 m <sup>3</sup> /d
Total desalination capacity	454,200 m <sup>3</sup> /d
Performance Ratio	<250 mg/L
Top brine temperature Nom/Max	110°C/112°C
Nominal seawater temperature	35°C
Performance Ratio	8.92
Number of stages	22 (19+3)
Design fouling allowance	0.12 m <sup>2</sup> /kW°C
Brine recycle concentration	1.37
Seawater to heat rejection section	25,400 tons per hour (t/h)
Brine recycle to heat recovery	29,000 t/h
Makeup seawater to deaerator	9,000 t/h
Brine blowdown	5,800 t/h
Equipment supplier	Fisia Italimpianti
Power plant production capacity	1,500 MW
Desal/power plant capital cost	\$1.6 billion

Power and water capacities are nominal and may differ slightly from licensed values

The Shuweihat S1 Independent Water and Power Project consists of a greenfield power generation and water desalination facility located approximately 260 km west of the city of Abu Dhabi. The IWPP project was developed on a build, own, and operate basis by Shuweihat CMS International

Power Company (SCIPCO), a private joint stock company. The company is owned by ADWEA (60%), CMS (20%) and International Power (20%).

Operations and maintenance (O&M) of the plant has been undertaken under the terms of a 20-year O&M Agreement with Shuweihat O&M Limited Partnership, a company formed specifically by CMS Energy and International Power for this purpose. Both CMS Energy and International Power own 50% of the O&M Company, and will select “key” staff to direct and manage the O&M Company.

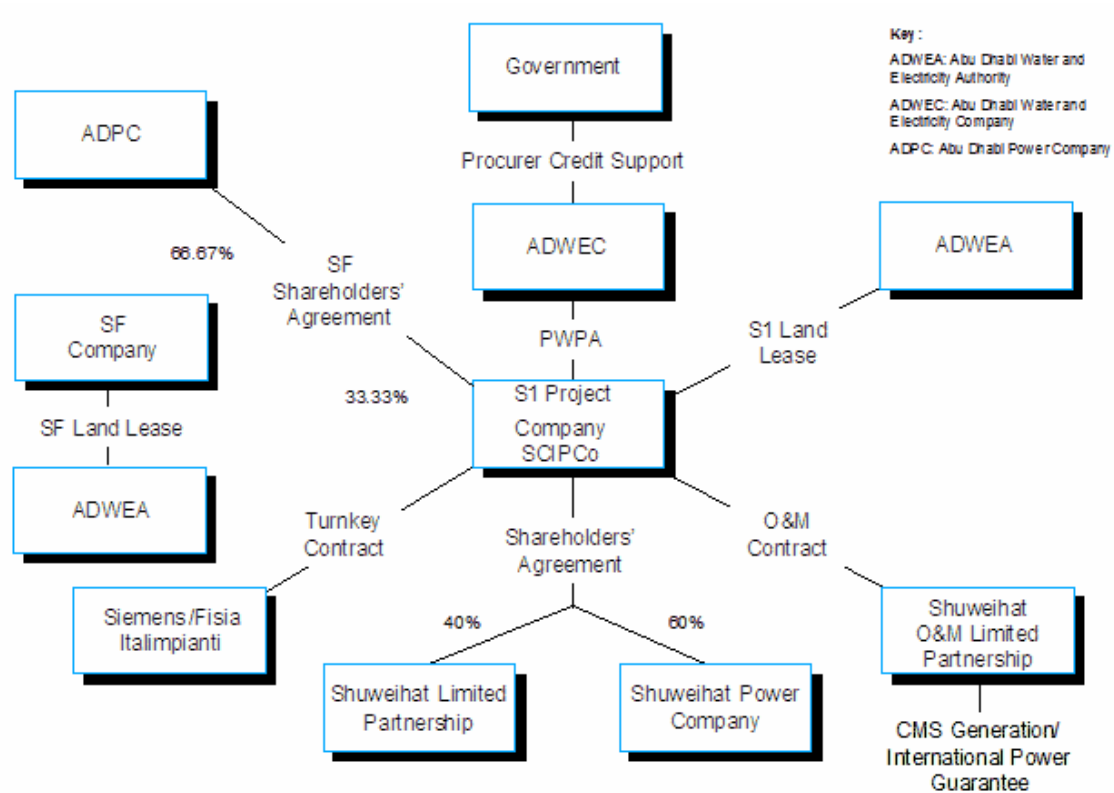

**SCIPPO Project Structure.**

### World's Largest MSF Units

At a nominal capacity of 75,700 m<sup>3</sup>/d per unit, the six MSF units are 30% larger than the previous largest units built. The distillers use 70 MW of power capacity to reach the full production of 454,200 m<sup>3</sup>/d.

Each unit has 200,000 m<sup>2</sup> of heat transfer surface area. The tube material in the heat recovery section is copper-nickel, while titanium is used for the heat reject section tubes. The shell material is carbon steel hot-roll clad with stainless steel.

## Innovative Condensate Cooler

A modification to the operating cycle was introduced to recover the excess heat in the condensate back into the MSF cycle, reducing both stack loss and MSF steam consumption. This is accomplished through the use of a small heat exchanger located in the brine heater condensate return stream.

The heat exchanger cools the condensate return flow using product water from the last heat recovery stage. The “product recycle” is heated in the heat exchanger as the brine heater condensate flow is cooled.

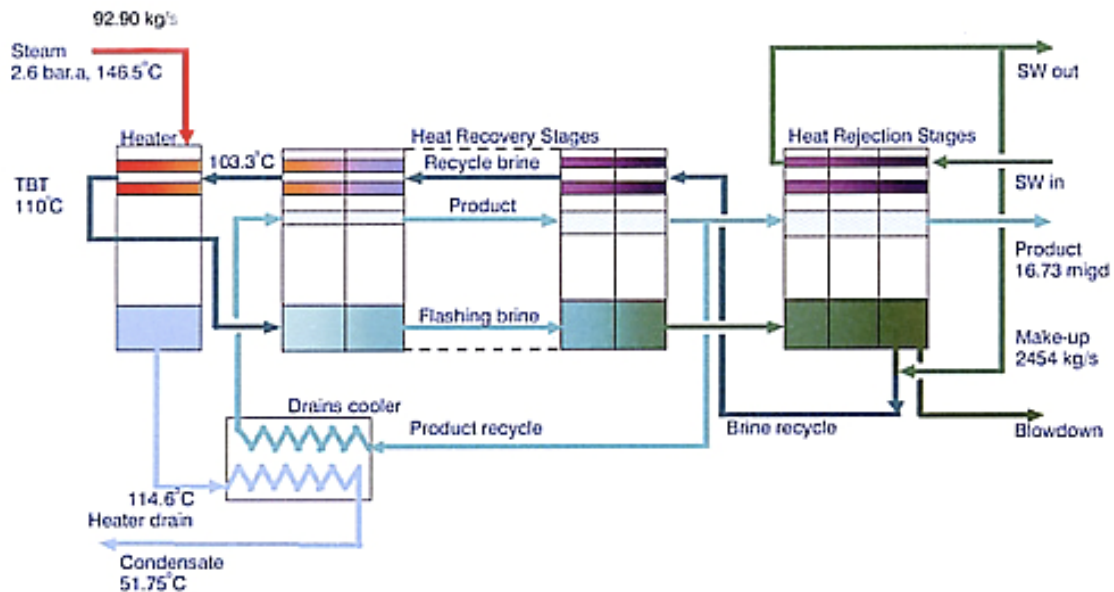

**Modified MSF Flow Diagram.**

The condensate cooler is a simple but patented addition to the basic MSF distiller. It requires a small external heat exchanger, pump, and some piping, and it requires no significant change to the basic distiller design other than the need to accommodate a slightly larger flow in the product trough of the heat recovery stages. The costs associated with the modification are less than 0.1% of the capital cost, yet it achieved a 6% steam reduction from the MSF process and a fuel saving of 1.5 to 2%, with corresponding reductions in CO<sub>2</sub> emissions.

The system was developed and patented by PB Power who served as the owner's engineer for the Shuweihat project.