

**NIST Measurement Services:**

---

# **Optical Fiber Power Meter Nonlinearity Calibrations at NIST**

**NIST  
Special  
Publication  
250-56**

**Igor Vayshenker  
Shao Yang  
Xiaoyu Li  
Thomas R. Scott  
Christopher L. Cromer**

---



**T**he National Institute of Standards and Technology was established in 1988 by Congress to “assist industry in the development of technology . . . needed to improve product quality, to modernize manufacturing processes, to ensure product reliability . . . and to facilitate rapid commercialization . . . of products based on new scientific discoveries.”

NIST, originally founded as the National Bureau of Standards in 1901, works to strengthen U.S. industry’s competitiveness; advance science and engineering; and improve public health, safety, and the environment. One of the agency’s basic functions is to develop, maintain, and retain custody of the national standards of measurement, and provide the means and methods for comparing standards used in science, engineering, manufacturing, commerce, industry, and education with the standards adopted or recognized by the Federal Government.

As an agency of the U.S. Commerce Department’s Technology Administration, NIST conducts basic and applied research in the physical sciences and engineering, and develops measurement techniques, test methods, standards, and related services. The Institute does generic and precompetitive work on new and advanced technologies. NIST’s research facilities are located at Gaithersburg, MD 20899, and at Boulder, CO 80303. Major technical operating units and their principal activities are listed below. For more information contact the Publications and Program Inquiries Desk, 301-975-3058.

---

### **Office of the Director**

- National Quality Program
- International and Academic Affairs

### **Technology Services**

- Standards Services
- Technology Partnerships
- Measurement Services
- Information Services

### **Advanced Technology Program**

- Economic Assessment
- Information Technology and Applications
- Chemistry and Life Sciences
- Materials and Manufacturing Technology
- Electronics and Photonics Technology

### **Manufacturing Extension Partnership Program**

- Regional Programs
- National Programs
- Program Development

### **Electronics and Electrical Engineering Laboratory**

- Microelectronics
- Law Enforcement Standards
- Electricity
- Semiconductor Electronics
- Radio-Frequency Technology<sup>1</sup>
- Electromagnetic Technology<sup>1</sup>
- Optoelectronics<sup>1</sup>

### **Materials Science and Engineering Laboratory**

- Intelligent Processing of Materials
- Ceramics
- Materials Reliability<sup>1</sup>
- Polymers
- Metallurgy
- NIST Center for Neutron Research

### **Chemical Science and Technology Laboratory**

- Biotechnology
- Physical and Chemical Properties<sup>2</sup>
- Analytical Chemistry
- Process Measurements
- Surface and Microanalysis Science

### **Physics Laboratory**

- Electron and Optical Physics
- Atomic Physics
- Optical Technology
- Ionizing Radiation
- Time and Frequency<sup>1</sup>
- Quantum Physics<sup>1</sup>

### **Manufacturing Engineering Laboratory**

- Precision Engineering
- Automated Production Technology
- Intelligent Systems
- Fabrication Technology
- Manufacturing Systems Integration

### **Building and Fire Research Laboratory**

- Applied Economics
- Structures
- Building Materials
- Building Environment
- Fire Safety Engineering
- Fire Science

### **Information Technology Laboratory**

- Mathematical and Computational Sciences<sup>2</sup>
- Advanced Network Technologies
- Computer Security
- Information Access and User Interfaces
- High Performance Systems and Services
- Distributed Computing and Information Services
- Software Diagnostics and Conformance Testing
- Statistical Engineering

---

<sup>1</sup> At Boulder, CO 80303.

<sup>2</sup> Some elements at Boulder, CO.

NIST Special Publication 250-56

# **NIST MEASUREMENT SERVICES: Optical Fiber Power Meter Calibrations at NIST**

---

Igor Vayshenker  
Shao Yang\*  
Xiaoyu Li  
Thomas R. Scott  
Christopher L. Cromer

*Optoelectronics Division  
Electronics and Electrical Engineering Laboratory  
National Institute of Standards and Technology  
Boulder, CO 80303*

*\*Biostar  
6655 Lookout Road  
Boulder, CO 80301*

August 2000



---

U.S. Department of Commerce  
*Norman Y. Mineta, Secretary*

Technology Administration  
*Dr. Cheryl L. Shavers, Under Secretary of Commerce for Technology*

National Institute of Standards and Technology  
*Raymond G. Kammer, Director*

Certain commercial entities, equipment, or materials may be identified in this document in order to describe an experimental procedure or concept adequately. Such identification is not intended to imply recommendation or endorsement by the National Institute of Standards and Technology, nor is it intended to imply that the entities, materials, or equipment are necessarily the best available for the purpose.

**National Institute of Standards and Technology Special Publication 250-56**  
**Natl. Inst. Stand. Technol. Spec. Publ. 250-56, 34 pages (August 2000)**  
**CODEN: NSPUE2**

**U.S. GOVERNMENT PRINTING OFFICE**  
**WASHINGTON: 2000**

---

For sale by the Superintendent of Documents, U.S. Government Printing Office, Washington, DC 20402-9325

## Contents

1. Introduction	1
2. Measurement of Nonlinearity and Range Discontinuity	1
2.1 Definition and Basic Expressions	2
2.2 Polynomial Expression for Conversion Function	4
2.2.1 Triplet Superposition Method	5
2.3 Correction Factor for Nonlinearity and Range Discontinuity	6
3. Nonlinearity Measurement System	8
4. Uncertainty Assessment	11
5. References	17
Appendix A. Laser Diode Optical Spectra	18
Appendix B. Measurement Flow Chart	19
Appendix C. Sample of a Calibration Report	20

## **Optical Fiber Power Meter Nonlinearity Calibrations at NIST**

Igor Vayshenker, Shao Yang\*, Xiaoyu Li, Thomas R. Scott, and Christopher L. Cromer  
National Institute of Standards and Technology, 325 Broadway, Boulder, CO 80303

\*Biostar, 6655 Lookout Rd, Boulder, CO 80301

We describe a system for measuring the response nonlinearity of optical fiber power meters and detectors over a wide power dynamic range at telecommunication wavelengths. The system uses optical fiber components and is designed to accommodate commonly used optical fiber power meters. The system also measures the range discontinuities between neighboring power ranges or scale settings of the optical fiber power meter. Measurements with this system yield correction factors for all power ranges of the meter. The measurement system is capable of producing results which have standard deviations as low as 0.01 %. The measurement uncertainties associated with the system are described.

**Key words:** calibration; detector; linearity; measurement service; nonlinearity; optical fiber power meter; optical power; range discontinuity; uncertainty.

### **1. Introduction**

There are several methods currently used for the measurement of optical fiber power meter (OFPM) or detector nonlinearity: differential, attenuation, and superposition. These methods were compared analytically using a unified mathematical expression for nonlinearity [1-3]. Based on these results, we developed a system, which uses a superposition method known as the triplet method. This method relies on the principle that for a linear OFPM, the sum of the OFPM outputs corresponding to inputs from two individual beams should equal the output when the two beams are combined and incident on the OFPM at the same time. The triplet method does not require a standard; a measurement system based on the triplet method is the standard by itself.

### **2. Measurement of Nonlinearity and Range Discontinuity**

Generally, an OFPM has a dynamic range of more than 60 dB with many meters exceeding 90 dB. To achieve these dynamic ranges, an OFPM is designed to switch ranges during optical power measurements. The power ranges have their own gains or amplifications, which often differ by a factor of 10. When the meter switches from one range to another, it is critical that two neighboring ranges indicate the same power. If the power readings at these two ranges are not the same, then the OFPM has a range discontinuity (assuming the power has remained constant). A simplified schematic of a typical OFPM is depicted in Figure 1.

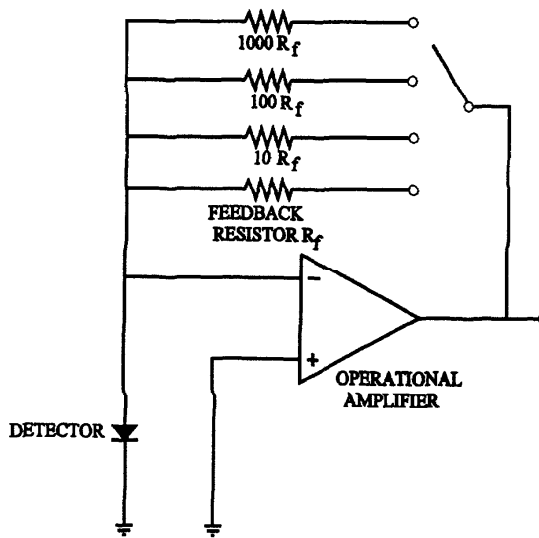

Figure 1. Simplified schematic of a typical optical power meter.

The NIST nonlinearity system is capable of measuring the nonlinearity of OFPMs over a dynamic range of more than 60 dB at the three nominal telecommunication wavelengths: 850, 1300, and 1550 nm. This system uses optical fiber components and is designed to accommodate commonly used OFPMs and other optical detectors. The system also measures the range discontinuity between neighboring power ranges or scale settings of the OFPM. Measurements with this system yield a correction factor for each power range of an OFPM. Note: for a bare detector, the ranges may be the electrical voltage or current ranges of the output electronics.

### 2.1 Definition and Basic Expressions

The nonlinearity of an OFPM is defined as the relative difference between the responsivity at an arbitrary power and the responsivity at the calibration power (i.e., the power at which the meter was calibrated). This definition can be expressed as

$$\Delta_{NL}(P;P_c) = \frac{R(P) - R(P_c)}{R(P_c)}, \quad (1)$$

where  $R(P) = V/P$  is the responsivity of the OFPM at incident optical power  $P$ ; the subscript  $c$  indicates the calibration point, and  $V$  is the OFPM output, which can be electrical current,

voltage, or the display reading from the OFPM. A function that describes the relationship between the incident optical power  $P$  and an OFPM or detector output is called the response function and is expressed as:

$$V = V(P). \tag{2}$$

The response function is depicted in Figure 2. We can express the nonlinearity of eq (1) in terms of the response function:

$$\Delta_{NL}(P;P_c) = \frac{V(P)P_c}{V(P_c)P} - 1. \tag{3}$$

The inverse function (when the dependent and independent axes are switched) of the response function is called the conversion function and is depicted in Figure 3. This conversion function converts the output  $V$  to the input power  $P$  and is expressed as

$$P = P(V). \tag{4}$$

The response function and the conversion function represent the same physical quantity in inverted variables. Consequently, the nonlinearity can equivalently be expressed and calculated in terms of the response function and input power  $P$ .

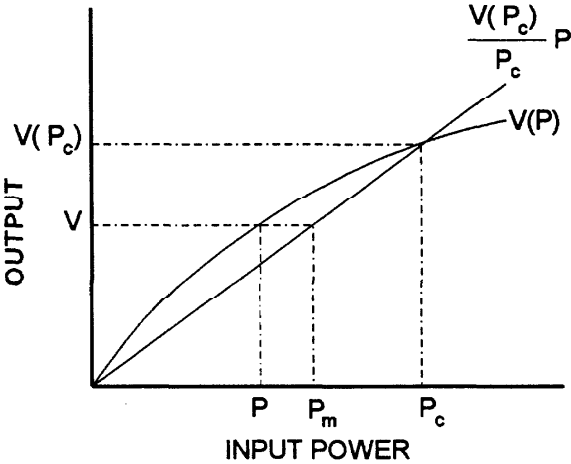

Figure 2. A response function.



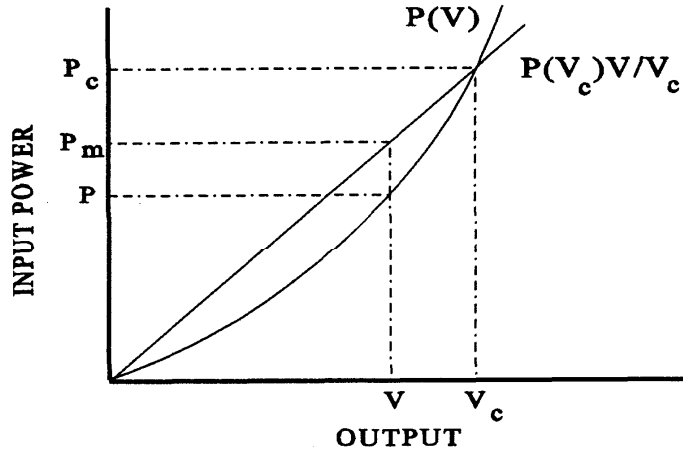

Figure 3. A conversion function.

In practice, it is often more convenient to use the conversion function rather than the response function. We can define the nonlinearity in terms of the output  $V$  as

$$\Delta_{NL}(V; V_c) = \frac{P(V_c)V}{P(V)V_c} - 1. \quad (5)$$

## 2.2 Polynomial Expression for Conversion Function

When the nonlinearity is small, a polynomial can represent the conversion function well [4,5]; that is

$$P(V) = \sum_{k=1}^n a_k V^k, \quad (6)$$

where  $n$  is the order of the polynomial and  $a_k$  are the coefficients of the polynomial. The coefficients  $a_k$  correspond to a calibrated conversion function [1].

The output responses of the commonly used photodiodes, Si, Ge, or InGaAs, are exponential (see conversion function in Figure 3) with respect to the input power. However, they are often used in nearly short-circuited or reverse-biased configurations to achieve a linear response. As a result, their responses can be approximated as polynomials produced by the Taylor-series expansion of the form shown in eq (6), where the zero-order term is not included because we always measure the dark signal and later subtract it from the output of an OFPM. With the assumption of

$$\sum_{k=2}^n \frac{a_k}{a_1} V^{k-1} \ll 1,$$

the nonlinearity  $\Delta_{NL}$  of eq (5) can be approximated by (for the nonlinearity of less than 1 %, the approximation error is less than 0.01 %)

$$\Delta_{NL}(V; V_c) \approx -\sum_{k=2}^n \frac{a_k}{a_1} (V^{k-1} - V_c^{k-1}). \quad (7)$$

If we divide all the coefficients  $a_k$  in eq (6) by the first coefficient  $a_1$ , the polynomial thus obtained is called the normalized conversion function, denoted by  $p(V)$  and expressed as

$$p(V) = V + \sum_{k=2}^n b_k V^k, \quad (8)$$

where  $b_k = a_k/a_1$ . The coefficients  $b_k$  correspond to an uncalibrated conversion function described in reference [1]. Typically,  $n$  is equal to 3.

The nonlinearity can be expressed as

$$\Delta_{NL}(V; V_c) \approx -\sum_{k=2}^n b_k (V^{k-1} - V_c^{k-1}). \quad (9)$$

### 2.2.1 Triplet Superposition Method

In the triplet superposition method, a group of three power measurements is made, two for individual powers from each beam and one for the combination of the two. For the  $i^{\text{th}}$  group of measurements, we have a set of three equations:

$$\left\{ \begin{array}{l} p_{1i} = V_{1i} + \sum_{k=2}^n b_k V_{1i}^k, \\ p_{2i} = V_{2i} + \sum_{k=2}^n b_k V_{2i}^k, \\ p_{1i} + p_{2i} = V_{3i} + \sum_{k=2}^n b_k V_{3i}^k, \end{array} \right. \quad (10)$$

where the  $p_i$  are arbitrary unknowns and the  $V_i$  are measured output values. A new equation is formed by subtracting the first and second equations from the third equation while eliminating the unknown  $p_i$  in the group of the three equations in eq (10):

$$(V_{3i} - V_{1i} - V_{2i}) + \sum_{k=2}^n b_k (V_{3i}^k - V_{1i}^k - V_{2i}^k) = 0. \quad (11)$$

The coefficients  $b_k$  can be obtained by linear least-squares fitting of the measured data. The three measurement runs are usually made in immediate succession, which helps reduce the uncertainty that might occur due to drift of the laser source output. The details of the measurements are described in Section 3.

### 2.3 Correction Factor for Nonlinearity and Range Discontinuity

While calibration gives the true relationship between the input power and the OFPM reading (output) at the calibration point, the measurement of nonlinearity and range discontinuity, together with calibration, provides this input-output relation at any power over the whole dynamic range of the OFPM. It is, therefore, convenient to express the measured nonlinearity,  $\Delta_{NL}(V;V_c)$  in terms of the conversion function  $P = P(V)$ , which relates the input power  $P$  to the output  $V$ , referred to the calibration output  $V_c$ .

We denote the range setting of the OFPM with brackets;  $[m]$  denotes some range  $m$  ( $m = 1, 2, 3, \dots$ ), and  $[c]$  is the range where the reference power is used. Calibration determines  $a_1$  in range  $[c]$  where the calibration reference point is selected;  $P_c$  is the calibration power at a reference power of approximately  $100 \mu\text{W}$  and  $V_c$  is the calibration output as shown below:

$$a_1[c] = \frac{P_c}{V_c + \sum_{k=2}^n b_k[c] V_c^k} \quad (12)$$

The true input power  $P$  is obtained from the OFPM reading  $V$  for any given range  $m$  by

$$P = \frac{V}{F_c \cdot CF[m]}, \quad (13)$$

where  $F_c = V_c/P_c$  is the calibration factor described in reference [6] and  $CF[m]$  is a correction factor for nonlinearity over the entire range  $m$  and range discontinuity in any range (except the range that corresponds to the lowest power used in a nonlinearity calibration). This correction factor can be calculated by:

$$CF[m] = \frac{a_1[c]}{a_1[m]} \times \frac{1 + \sum_{k=2}^n b_k[c] V_c^{k-1}}{1 + \sum_{k=2}^n b_k[m] V^{k-1}}, \quad (14)$$

where the discontinuity coefficients  $a_1[m]$  outside range  $[c]$  are determined using eqs (15) and (16):

$$\frac{a_1[c]}{a_1[m]} = \frac{a_1[c]}{a_1[c+1]} \times \dots \times \frac{a_1[m-1]}{a_1[m]} \quad \text{for } m > c, \quad (15)$$

or

$$\frac{a_1[c]}{a_1[m]} = \frac{1}{\frac{a_1[m]}{a_1[m+1]} \times \dots \times \frac{a_1[c-1]}{a_1[c]}} \quad \text{for } c > m. \quad (16)$$

The coefficients of the noncalibrated conversion function  $b_k[m]$  in eq (14), are determined from the measured nonlinearity by means of a least squares curve fitting. The ratio of  $a_1$  between two neighboring ranges  $a_1[m]/a_1[m+1]$  is determined by the measured range discontinuity. Typically, we use a third-order polynomial ( $n = 3$ ) to calculate the correction factor in eq (14). Each range of an OFPM has its own correction factor.

### 3. Nonlinearity Measurement System

The NIST OFPM nonlinearity system is depicted in Figure 4. The system is fully automated. After the measurements are completed (typically in 3 h), the computer program analyzes the data and prints the calibration data in a table form. We use high-power, single-mode, fiber-pigtailed lasers whose powers are stabilized. All the lasers are temperature controlled for power and wavelength stability. An external optical attenuator with a dynamic range of more than 60 dB provides variable optical power. The output of the attenuator is divided into two approximately equal parts by using a fiber splitter; one of the splitter arms has an additional length of fiber (approximately 100 m, compared to the coherence length of the laser of only a few centimeters) to avoid interference. A computer-controlled shutter is inserted into a collimated beam in each arm. Both signals are combined in a fiber coupler which has an FC/APC connector at the output to decrease reflections back to the laser and other components of the measurement system. We use single-mode fiber components (e.g., splitters and couplers) throughout the system. Loose system fibers are wrapped on spools 5 cm in diameter to minimize transient microbend losses. Also, in this regard, all fibers are securely fixed so that they cannot move during the measurements. All the lasers are of Fabry-Perot type and have several longitudinal (spectral) modes (see Appendix A).

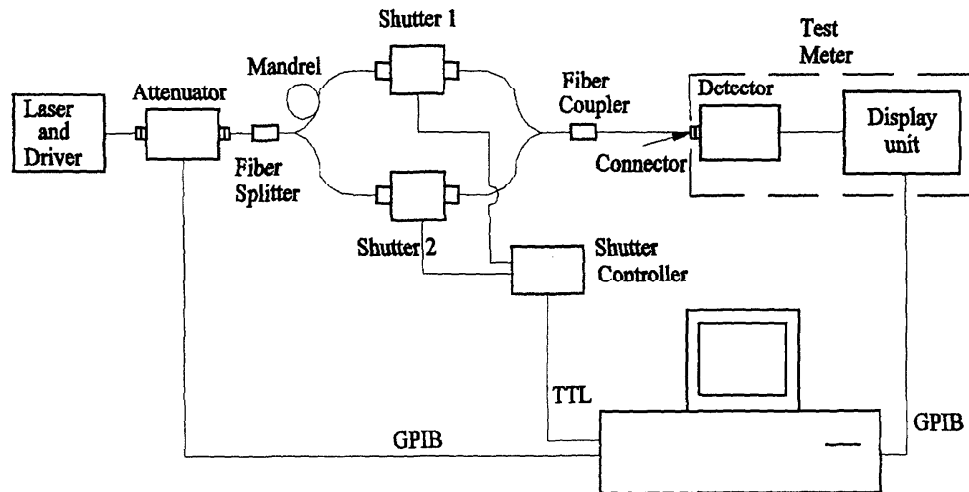

Figure 4. The nonlinearity measurement system.

The data are acquired using the triplet superposition method. The measurements are performed by taking three power readings from the OFPM: (1) when the shutter 1 is open (1 s) and shutter 2 is closed, (2) when both shutters are open (1 s), and (3) when the shutter 1 is closed and shutter 2 is open (1 s). These three power measurements are called a triplet. Shutters are controlled by the computer, which sends a TTL signal to the shutter controller. This sequence is then repeated at different powers. The OFPM response is linear when the sum of the two individual power readings is equal to the combined-power reading. We usually divide each power range of an OFPM into 10 parts or sets spaced equally in the logarithmic scale. Each set is a triplet measurement taken three times and averaged. Each single measurement in a triplet is taken three times as well, and the result is averaged. Thus, there are 27 single measurements for each set. Generally, there are total of 270 single measurements per single power range. If an OFPM has six ranges, the computer will take 1,620 single measurements for one run. The computer takes three runs to calculate the final results. Thus, to measure an OFPM nonlinearity, the computer will collect nearly 5,000 single measurements. For each measurement run, the averaged data, grouped in three columns are saved on the hard drive of the computer. Each row of the data represents a measurement set of a triplet.

To measure the range discontinuity (offsets between ranges or scales), readings are taken at the lower-power end of each range and compared to the readings on the higher-power end of the next lower range at the same input power. Generally, three sets of measurements for each range are taken to calculate the range discontinuity. When shutter 1 is closed and shutter 2 is open, five single measurements are taken (and averaged) for two neighboring ranges. Then, three values of the range discontinuity (for each range except the lowest one) is stored in the data file. The background or offset of each range is measured and the value is subtracted from the signal.

Using the system shown in Figure 4, the nonlinearity of an OFPM is characterized over the power between 1.5 nW and 3.5 mW at a wavelength of 1314 nm. Sample results obtained on a NIST OFPM are presented in Table 1 and shown graphically in Figure 5, in which a symbol represents a power range of an OFPM. The correction factors result from meter nonlinearity within each range, combined with the range discontinuity. Most OFPMs use power ranges in decibels/meter units. **Note:** decibel/meter is not an SI unit, but is related to a power of 1 mW as  $10 \log(x)$ , where  $x$  is an unknown power in milliwatts. Each correction value listed in the Table 1 is the average of six correction factors (except the 10 dBm or 10 mW range, which is represented by only three points due to a limited laser power) found throughout that range. If the nonlinearity of an OFPM is not negligible, it is necessary to provide correction factors at each power, as for the highest power range in Figure 5, and avoid averaging correction factors as it is done for ranges with small nonlinearities. The flow chart of the measurement is shown in Appendix B.

To correct for nonlinearity and range discontinuity, the OFPM readings should be **divided** by the appropriate correction factors. The standard deviation of the correction factors for each range in Table 1 was calculated using three data runs. A sample copy of a calibration report is provided in Appendix C.

Table 1. Nonlinearity and range discontinuity correction factors.

	Meter range [m] (dBm)*	Output power	Mean correction factor	Standard deviation (%)
1:	10	1.5-3.5 mW	1.007	0.30
2:	0	0.15-2 mW	0.9995	0.06
3:	-10 [c]	15-200 $\mu$ W	1.000	0.01
4:	-20	1.5-20 $\mu$ W	0.9993	0.02
5:	-30	0.15-2 $\mu$ W	1.003	0.04
6:	-40	15-200 nW	1.002	0.06
7:	-50	1.5-20 nW	1.003	0.06

\* dBm is not an SI unit, but is related to a power of 1 mW as  $10 \log(x)$ , where x is an unknown power in milliwatts.

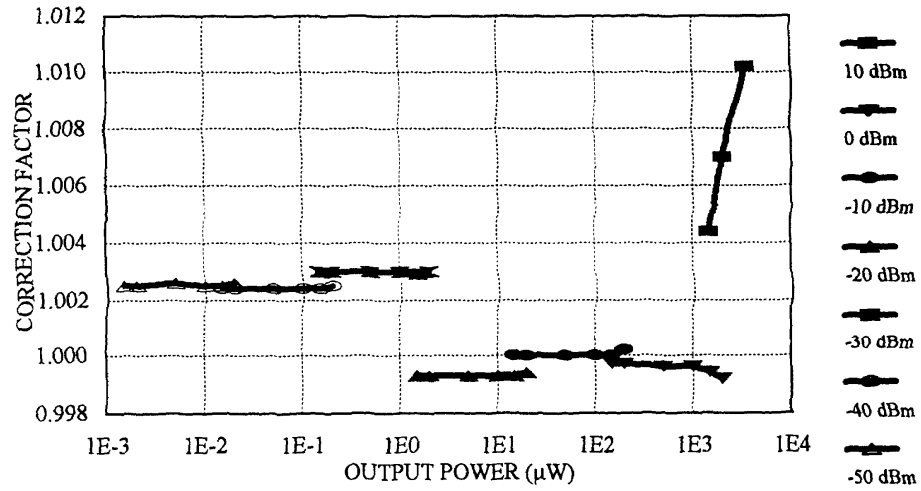

Figure 5. Correction factor versus output power.

#### 4. Uncertainty Assessment

In this section we assess the associated uncertainty of the OFPM nonlinearity measurements. The uncertainty estimates for the NIST OFPM nonlinearity measurements are described and combined using the referenced guidelines [7]. To establish the uncertainty limits, the uncertainty sources are separated into Type A, whose magnitudes are obtained statistically from a series of measurements, and Type B, whose magnitudes are determined by subjective judgement.

The Type A uncertainty components are assumed to be independent and, consequently, the standard deviation,  $S_r$ , for each component is

$$S_r = \sqrt{\frac{\sum_i x_i^2 - \frac{(\sum_i x_i)^2}{N}}{N-1}}, \quad (17)$$

where the  $x_i$  values represent the individual measurements and  $N$  is the number of  $x_i$  values used for a particular Type A component. The standard deviation of the mean is  $S_r/N^{1/2}$ , and the total standard deviation of the mean is  $[\sum(S_r^2/N)]^{1/2}$ , where the summation is carried out for all Type A components.

All the Type B components are assumed to be independent and have rectangular or uniform distributions (that is, each has an equal probability of being within the region,  $\pm\delta_s$ , and zero probability of being outside that region). If the distribution is rectangular, the standard deviation,  $\sigma_s$ , for each Type B component is equal to  $\delta_s/3^{1/2}$  and the total 'standard deviation' is  $(\sum\sigma_s^2)^{1/2}$ , where the summation is performed over all Type B components.

The combined uncertainty is determined by combining the Type A and Type B standard deviations in quadrature; the expanded uncertainty is obtained by multiplying this result by a coverage factor of 2. The expanded uncertainty,  $U$ , is then

$$U = 2 \sqrt{\sum_s \sigma_s^2 + \sum_r \frac{S_r^2}{N}}. \quad (18)$$

The number of decimal places used in reporting the mean values of the calibration factor are determined by expressing the expanded NIST uncertainty in percentage to two significant digits. In Table 2, we describe the nonlinearity of an OFPM calibration uncertainty using Type A and Type B components as follows:



### Type A

Repeatability: This is an uncertainty due to the scatter of data points around the measurement average obtained from three calibration runs on the OFPM being calibrated.

### Type B

a. Laser power stability: During the nonlinearity calibration of an OFPM, changes in optical power such as drift or fluctuations can cause a possible error. The power stability is measured during the time interval in which the three measurements are taken. The low power (when an individual shutter is open) is measured before and after the high power (when both shutters are open). The value for laser stability is found by measuring the drift for each laser source. The slope of the drift (percent per second) is then multiplied by the interval that the three shutters are open (3 s) during an actual nonlinearity calibration. The maximum measured value of the power drift is 0.21 % at 850 nm, and 0.09 % at 1300 nm and 1550 nm. The standard uncertainty for laser stability is  $0.21/(2\sqrt{3}) = 0.06$  % at 850 nm, and  $0.09/(2\sqrt{3}) = 0.03$  % at 1300 nm and 1550 nm.

b. Polynomial truncation: The conversion function of an OFPM is a least-squares fit to a third-order polynomial. The uncertainty is due to truncation of the polynomial of higher orders. The maximum value of the error can be found from Figure 9 of reference [1] and is equal to 0.007 %. The standard uncertainty is  $0.007/(2\sqrt{3}) = 0.002$  %.

c. Test meter spectral responsivity: This uncertainty is caused by drift of the source wavelength and a drift of the optical spectrum analyzer during each triplet measurement. The size of the uncertainty depends on the absorbing material of the power meter detector. The value is estimated based on the spectral responsivity curves for Si, Ge, and InGaAs detectors. We assume a combined variation for the lasers wavelengths and accuracy of the optical spectrum analyzer of 0.1 nm.

Table 2 lists typical spectral responsivity slopes (percent per nanometer) for Si, Ge, and InGaAs detectors used in most OFPMs.

Table 2. Spectral responsivity slope (percent per nanometer) for Si, Ge, and InGaAs detectors.

Diode type	Wavelength (nm)		
	850	1300	1550
Si	0.14	NA	NA
Ge	0.48	0.14	0.92
InGaAs	0.53	0.09	0.05

Table 3. Standard uncertainty (%) for spectral responsivity for Si, Ge, and InGaAs detectors.

Diode Type	Wavelength (nm)		
	850	1300	1550
Si	0.004	NA	NA
Ge	0.014	0.004	0.027
InGaAs	0.015	0.003	0.001

Table 3 presents the standard uncertainty values for Si, Ge, and InGaAs detectors. The standard uncertainty due to this wavelength effect is equal to the appropriate value from Table 2 multiplied by 0.1 nm and divided by  $2\sqrt{3}$ .

d. Equation approximation: This uncertainty is due to the approximation defined by eq (7). The uncertainty is of second-order in magnitude, i.e., if the nonlinearity is 1 %, then the uncertainty is  $(0.01)^2$  or  $10^{-4}$ . This uncertainty depends on the value for the nonlinearity in each case. The maximum uncertainty will be divided by  $(2\sqrt{3})$ .

e. Polarization: This uncertainty is due to effects caused by changes in polarization of the incident power during each triplet measurement set. This uncertainty is related to polarization dependent loss (PDL) of the nonlinearity system. Polarization uncertainty of the nonlinearity system is assumed to be small because we take a large number of measurements (810 measurements per one power range) and because measurement time scales are short compared to changes in the system polarization state. The PDL of the nonlinearity system was measured using a random-polarization generator. The maximum value of the system PDL is 0.002 dB or 0.05 %. The standard uncertainty is  $0.05/(2\sqrt{3}) = 0.014$  %.

Tables 4 through 6 list typical measurement uncertainties for calibrations of OFPMs which use Si, Ge, and InGaAs detectors, respectively. The exact values of these various components change for the particular measurement conditions at the time of the measurement.

Table 4. Example of nonlinearity measurement uncertainties for a Si optical fiber power meter at 850 nm.

Source	Standard uncertainty (type) (%)
Laser stability @ 850 nm	0.06 (B)
Polynomial truncation	0.002 (B)
Test meter spectral responsivity @ 850 nm (Si)	0.004 (B)
Equation approximation*	0.026 (B)
Polarization	0.014 (B)
Repeatability (N = 3)	0.05 (A)
Combined uncertainty	0.073
Expanded uncertainty (k = 2)	0.15

\* This uncertainty depends on the nonlinearity value for each particular case.

**Table 5. Example of nonlinearity measurement uncertainties for a Ge optical fiber power meter at 1300 nm.\***

Source	Standard uncertainty (type) (%)
Laser stability @ 1300 nm	0.03 (B)
Polynomial truncation	0.002 (B)
Test meter spectral responsivity @ 1300 nm (Ge)	0.004 (B)
Equation approximation**	0.003 (B)
Polarization	0.014 (B)
Repeatability (N = 3)	0.07 (A)
Combined uncertainty	0.053
Expanded uncertainty (k = 2)	0.11

\* For other wavelengths, use the appropriate uncertainty arising from a test meter spectral responsivity (Table 3).

\*\* This uncertainty depends on the nonlinearity value for each particular case.

Table 6. Example of nonlinearity measurement uncertainties for a InGaAs optical fiber power meter at 1550 nm.\*

Source	Standard uncertainty (type) (%)
Laser stability @ 1550 nm	0.01 (B)
Polynomial truncation	0.002 (B)
Test meter spectral responsivity @ 1550 nm (InGaAs)	0.0014 (B)
Equation approximation**	0.012 (B)
Polarization	0.014 (B)
Repeatability (N = 3)	0.03 (A)
Combined uncertainty	0.039
Expanded uncertainty (k = 2)	0.08

\* For other wavelengths, use the appropriate uncertainty arising from a test meter spectral responsivity (Table 3).

\*\* This uncertainty depends on the nonlinearity value for each particular case.

---

This work was supported in part by the Calibration Coordination Group (CCG) of the Department of Defense; the lead agency for this project is the U.S. Naval Warfare Assessment Division, Corona, California and NIST's Calibration Services Development Fund. Kent Rochford, Steven Mechels, Rex Craig, and Jack Wang of NIST reviewed the manuscript; the authors thank them for their valuable comments.

## 5. References

- [1] Yang, S.; Vayshenker, I.; Li, X.; Zander M.; Scott, T.R. Optical detector nonlinearity: Simulation. Natl. Inst. Stand. Technol. Technical Note 1376; May 19, 1995.
- [2] Yang, S.; Vayshenker, I.; Li, X.; Scott, T.R. Optical detector nonlinearity: a comparison of five methods, Digest, Conf. Precision Electromagnetic Measurements: 455-456; June-July 1994.
- [3] Yang, S.; Vayshenker, I.; Li, X.; Scott, T.R. Accurate measurement of optical detector nonlinearity. Proc., Natl. Conf. Standards Laboratories Workshop & Symposium, Session 5A: 353-362; July-August, 1994.
- [4] Vayshenker, I.; Yang, S.; Li, X.; Scott, T.R. Automated measurement of nonlinearity of optical fiber power meters. Proc. Int. Symp. IMEKO, Vol. 2550, San Diego, CA; July 11-12; 1995.
- [5] Vayshenker, I.; Yang, S.; Li, X.; Scott, T.R. Nonlinearity of optical power meters. Natl. Inst. Stand. Technol. Spec. Publ. 905: 101-104; 1996.
- [6] Vayshenker, I.; Li, X.; Livigni, D.J.; Scott, T.R.; Cromer, C.L. Optical fiber power meter calibration at NIST. To be published as Natl. Inst. Stand. Technol. Spec. Publ. 250-54, 2000.
- [7] Taylor, B.N.; Kuyatt, C.E. Guidelines for evaluating and expressing the uncertainty of NIST measurement results. Natl. Inst. Stand. Technol. Tech. Note 1297; January 1993.

**Appendix A. Laser Diode Optical Spectra**

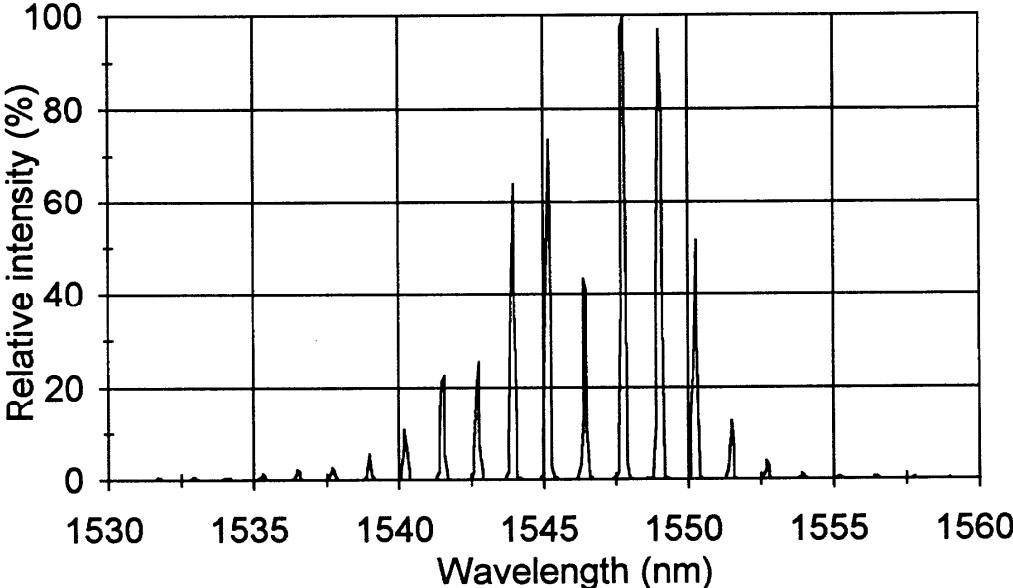
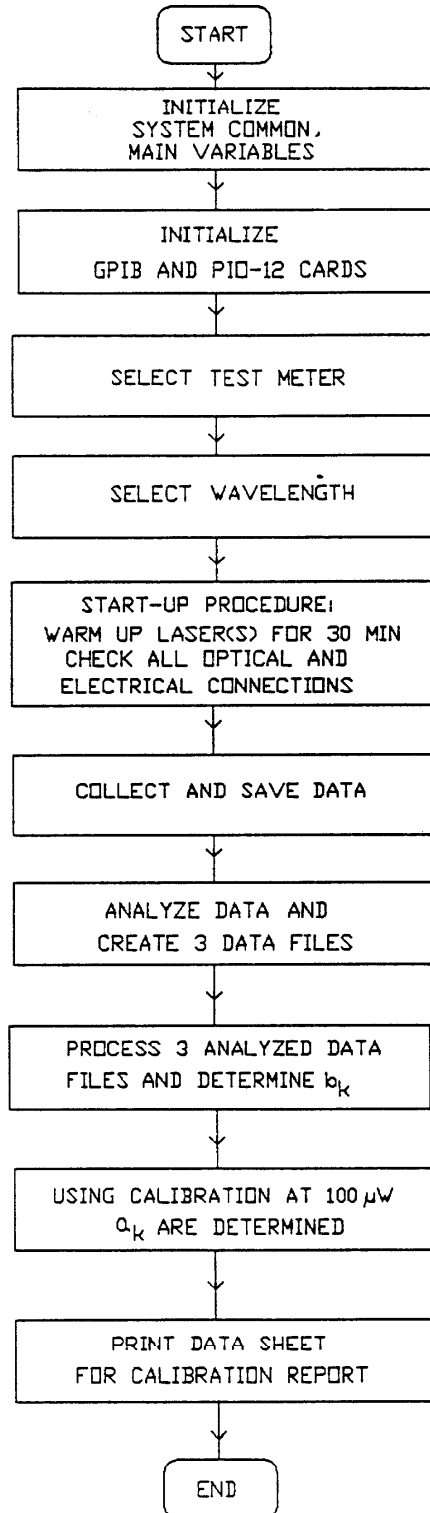

Figure A-1. Optical spectra of a typical laser diode used in the linearity calibration system.

## Appendix B. Measurement Flow Chart





## Appendix C. Sample of a Calibration Report

U.S. DEPARTMENT OF COMMERCE  
NATIONAL INSTITUTE OF STANDARDS AND TECHNOLOGY  
ELECTRONICS & ELECTRICAL ENGINEERING LABORATORY  
Boulder, Colorado 80303

# REPORT OF NONLINEARITY CALIBRATION for

## OPTICAL POWER METER

Meter's Manufacturer

Model Number

with Sensors

Model Number X, Serial Number 1

Model Number Y, Serial Number 2

Submitted by:

Company name

Address

### Nonlinearity Measurement Summary

Using the system shown in Figure 1, the nonlinearity of the optical fiber power meter (OFPM) was characterized over the following ranges: (1) 150 pA to 600  $\mu$ A at a wavelength of 860 nm for Model X with S/N 1 (Si), and (2) 150 pA to 600  $\mu$ A at 860 nm, 150 pA to 2.0 mA at 1314 nm and 1542 nm for Model Y with S/N 2. The data were acquired and analyzed using the triplet superposition method in which measurements were performed by taking sets of three power readings from the test meter with: (1) shutter 1 open, shutter 2 closed, (2) both shutters open, and (3) shutter 1 closed, shutter 2 open. This sequence was then repeated at different powers. In principle, the detector is considered linear when the sum of the two individual power readings is equal to the combined power reading. The actual equations used to characterize the degree of nonlinearity and resulting correction factors are discussed in the next section of this report. To measure range discontinuity (i.e., offsets between range or scale settings), readings were taken at the lower power end of each range and compared to the readings on the higher power region of the next lower range (if available) at a constant power.

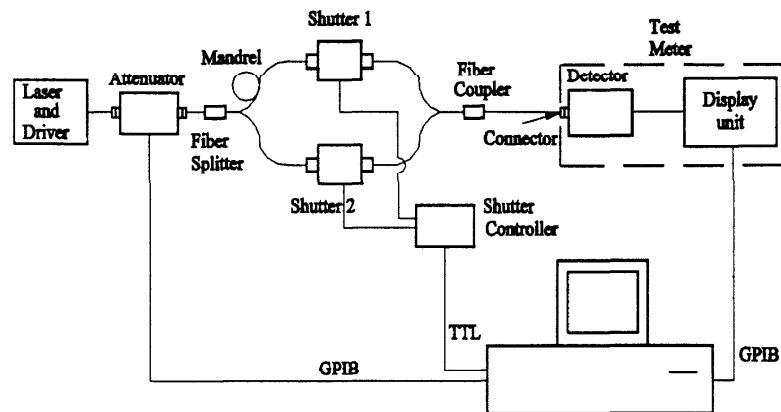

Figure 1. The nonlinearity measurement system.

Folder No. & NISTID: 26000 & 81300  
Date of Report: April 30, 2000  
Reference: P.O. No. 2121 04/15/00

1 of 10

OPTICAL POWER METER

Meter's Manufacturer

Model Number, Serial Number

with Sensors

Model Number X, Serial Number 1

Model Number Y, Serial Number 2

The results of these measurements are presented in Tables 1 through 4 and shown graphically in Figures 2 through 5. To correct for nonlinearity and range discontinuity, the OFPM readings should be divided by the appropriate correction factors in Tables 1 through 4. The correction factors result from meter/detector nonlinearity within each range combined with the range discontinuity (i.e., offsets between ranges). Except for the third, fourth, and fifth ranges for Model Y, S/N 2 detector at 860 nm, each correction value listed in the table is the average of six correction factors found throughout that particular range. Because of the observed nonlinearity, the correction factors for these ranges at 860 nm are for individual powers rather than for the entire range. The uncertainty values listed in Table 1 through 4. The laboratory temperature during these measurements was 22 °C (±2 °C) and the relative humidity was 11 % (±4 %).

Table 1. Nonlinearity correction factors (CF) at 860 nm for optical fiber power meter, Model Number X, Serial Number 1.

Meter/scale range	Output current	CF	Standard deviation for 3 runs (%)	Expanded uncertainty of CF (%)
3	150-600 μA	1.000	0.08	0.12
4	15-200 μA	1.001	0.04	0.08
5	1.5-20 μA	1.000	0.02	0.07
6	150-2000 nA	0.9998	0.03	0.08
7	15-200 nA	0.9993	0.03	0.08
8	1.5-20 nA	0.9995	0.05	0.09
9	150-2000 pA	0.9988	0.03	0.08

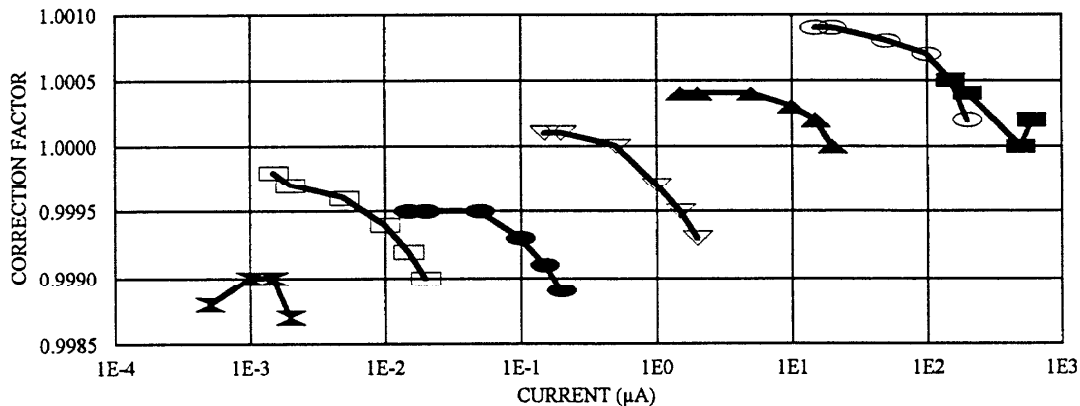

Figure 2. Correction factor versus output current at 860 nm for optical fiber power meter, Model Number X, Serial Number 1.

Folder No. & NISTID: 26000 & 81300  
 Date of Report: April 30, 2000  
 Reference: P.O. No. 2121 04/15/00

OPTICAL POWER METER

Meter's Manufacturer

Model Number, Serial Number

with Sensors

Model Number X, Serial Number 1

Model Number Y, Serial Number 2

Table 2. Nonlinearity correction factors (CF) at 860 nm for optical fiber power meter, Model Number Y, Serial Number 2.

Meter/scale range	Output current	CF	Standard deviation for 3 runs (%)	Expanded uncertainty of CF (%)
3	600 $\mu$ A	1.014	0.02	0.08
	200 $\mu$ A	1.006	0.01	0.08
	150 $\mu$ A	1.004	0.01	0.08
4	200 $\mu$ A	1.005	0.02	0.08
	100 $\mu$ A	1.002	0.00	0.07
	20 $\mu$ A	0.9979	0.01	0.08
5	20 $\mu$ A	0.9969	0.04	0.09
	10 $\mu$ A	0.9963	0.03	0.08
6	2 $\mu$ A	0.9954	0.05	0.09
	150-2000 nA	0.9948	0.03	0.08
7	15-200 nA	0.9941	0.02	0.08
8	1.5-20 nA	0.9941	0.05	0.09
9	150-2000 pA	0.9932	0.08	0.12

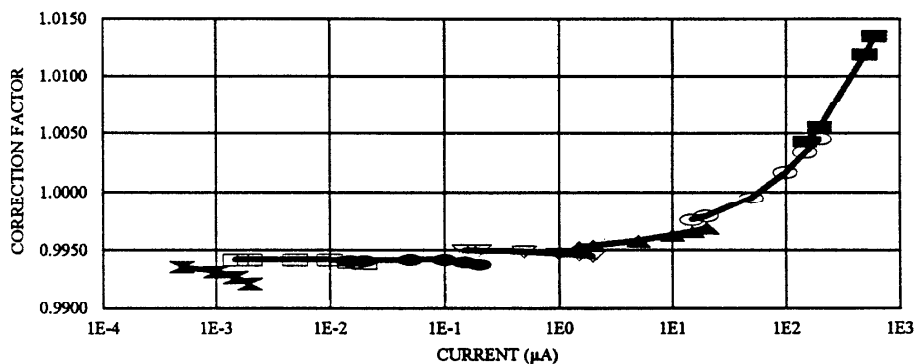

Figure 3. Correction factor versus output current at 860 nm for optical fiber power meter, Model Number Y, Serial Number 2.

Folder No. & NISTID: 26000 & 81300  
 Date of Report: April 30, 2000  
 Reference: P.O. No. 2121 04/15/00

OPTICAL POWER METER  
 Meter's Manufacturer  
 Model Number, Serial Number  
 with Sensors  
 Model Number X, Serial Number 1  
 Model Number Y, Serial Number 2

Table 3. Nonlinearity correction factors at 1314 nm for optical fiber power meter, Model Number Y, Serial Number 2.

Meter/scale range	Output current	CF	Standard deviation for 3 runs (%)	Expanded uncertainty of CF (%)
3	0.15-2 mA	0.9999	0.05	0.07
4	15-200 $\mu$ A	1.000	0.03	0.05
5	1.5-20 $\mu$ A	0.9998	0.03	0.05
6	0.15-2 $\mu$ A	0.9995	0.04	0.06
7	15-200 nA	0.9992	0.03	0.05
8	1.5-20 nA	0.9993	0.02	0.04
9	150-2000 pA	0.9984	0.08	0.10

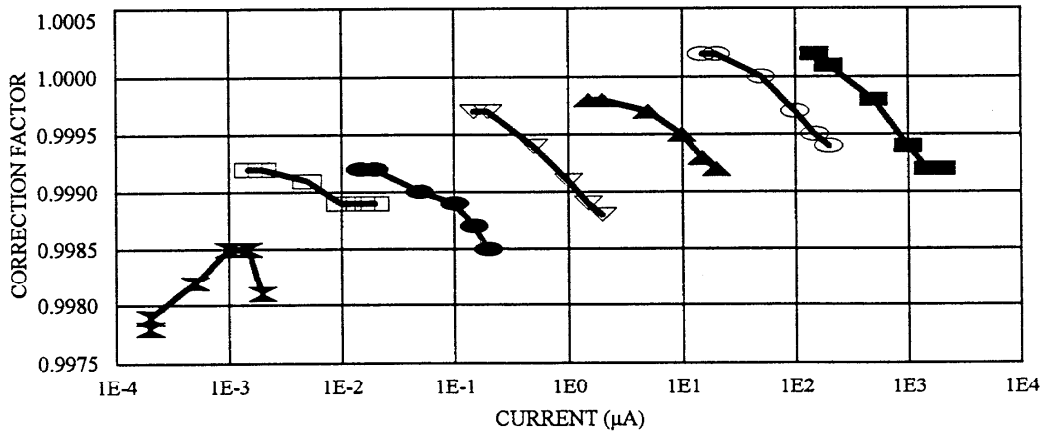

Figure 4. Correction factor versus output current at 1314 nm for optical fiber power meter, Model Number Y, Serial Number 2.

Folder No. & NISTID: 26000 & 81300  
 Date of Report: April 30, 2000  
 Reference: P.O. No. 2121 04/15/00

OPTICAL POWER METER  
 Meter's Manufacturer  
 Model Number, Serial Number  
 with Sensors  
 Model Number X, Serial Number 1  
 Model Number Y, Serial Number 2

Table 4. Nonlinearity correction factors (CF) at 1542 nm for optical fiber power meter, Model Number Y, Serial Number 2.

Meter/scale range	Output current	CF	Standard deviation for 3 runs (%)	Expanded uncertainty of CF (%)
3	0.15-2 mA	1.001	0.06	0.08
4	15-200 $\mu$ A	1.000	0.04	0.06
5	1.5-20 $\mu$ A	0.9997	0.03	0.05
6	0.15-2 $\mu$ A	0.9991	0.04	0.06
7	15-200 nA	0.9987	0.03	0.05
8	1.5-20 nA	0.9985	0.05	0.07
9	150-2000 pA	0.9990	0.17	0.20

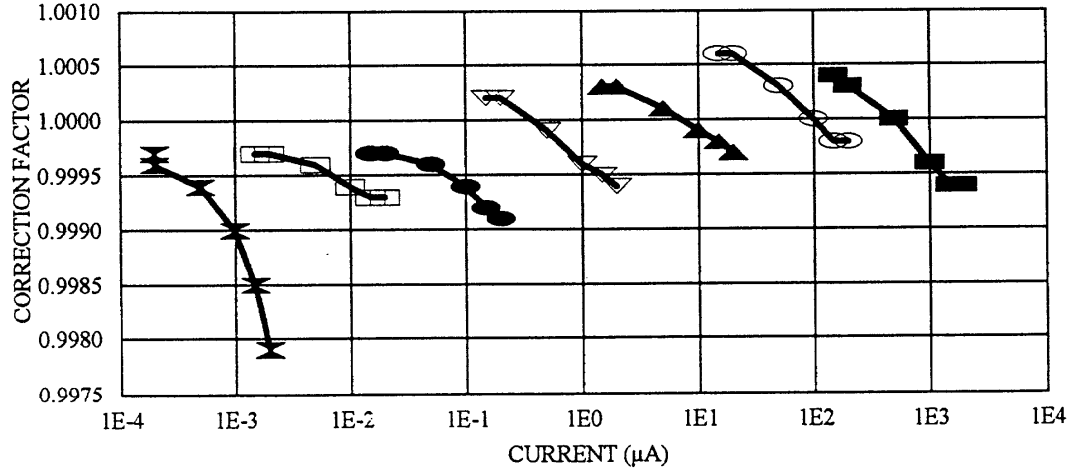

Figure 5. Correction factor versus output current at 1542 nm for optical fiber power meter, Model Number Y, Serial Number 2.

Folder No. & NISTID: 26000 & 81300  
 Date of Report: April 30, 2000  
 Reference: P.O. No. 2121 04/15/00

## OPTICAL POWER METER

Meter's Manufacturer

Model Number, Serial Number  
with Sensors

Model Number X, Serial Number 1

Model Number Y, Serial Number 2

### Correction Factor for Nonlinearity and Range Discontinuity

The nonlinearity of the OFPM and associated correction factors were found using the following guidelines. As mentioned earlier in the report, the outputs corresponding to the two individual beams and their combination are measured at different powers in each measurement range of the OFPM. Range discontinuity is also measured at several overlapping powers between two neighboring ranges.

The relationship between the incident power  $P$  and its corresponding reading  $V$  of the OFPM on any range,  $m$  is expressed as:

$$P = a_1[m](V + \sum_{k=2}^n b_k[m]V^k), \quad (1)$$

where  $n$  is the order of the polynomial,  $n = 3$ , and  $m$  indicates the measurement range.  $b_k[m]$  are determined from the measured nonlinearity by means of the least squares curve fitting. The range discontinuity between two neighboring ranges,  $m$  and  $m + 1$ , is found from  $a_1[m]/a_1[m + 1]$ .

When the OFPM is calibrated at power  $P_c$  which produces power meter reading,  $V_c$  in range  $[c]$ , the calibration factor  $F_c$  is determined by  $F_c = V_c/P_c$ . The correction factor  $CF[m]$  due to both nonlinearity and range discontinuity at any power reading  $V$  in any range  $[m]$  can be calculated by:

$$CF[m] = \frac{a_1[c]}{a_1[m]} \times \frac{1 + \sum_{k=2}^n b_k[c]V_c^{k-1}}{1 + \sum_{k=2}^n b_k[m]V^{k-1}}, \quad (2)$$

where

$$\frac{a_1[c]}{a_1[m]} = \frac{a_1[c]}{a_1[c+1]} \times \dots \times \frac{a_1[m-1]}{a_1[m]} \quad \text{for } m > c, \quad (3)$$

or

$$\frac{a_1[c]}{a_1[m]} = \frac{1}{\frac{a_1[m]}{a_1[m+1]} \times \dots \times \frac{a_1[c-1]}{a_1[c]}} \quad \text{for } c > m. \quad (4)$$

The incident power  $P[m]$  is obtained from the power meter reading  $V$  by for any given range  $m$  by

$$P[m] = \frac{V}{F_c \cdot CF[m]}. \quad (5)$$

Tables 1 through 4 list  $CF$  values for each measurement range. These  $CF$  values represent an average of the individual  $CF$  values found at various power levels within the range (except the ranges from 3 through 5 described in Table 2).

Folder No. & NISTID: 26000 & 81300  
Date of Report: April 30, 2000  
Reference: P.O. No. 2121 04/15/00

6 of 10

OPTICAL POWER METER  
 Meter's Manufacturer  
 Model Number, Serial Number  
 with Sensors  
 Model Number X, Serial Number 1  
 Model Number Y, Serial Number 2

**Uncertainty Assessment**

The uncertainty estimates in Tables 1 through 4 for the NIST linearity measurements are described and combined using the guidelines of NIST Technical Note 1297. To establish the uncertainty limits, the uncertainty sources are separated into Type A, whose magnitudes are obtained statistically from a series of measurements, and Type B, whose magnitudes are determined by subjective judgement.

The Type A uncertainty components are assumed to be independent and, consequently, the standard deviation,  $S_r$ , for each component is

$$S_r = \sqrt{\frac{\sum_i x_i^2 - \frac{(\sum_i x_i)^2}{N}}{N-1}}, \tag{6}$$

where the  $x_i$  values represent the individual measurements and N is the number of  $x_i$  values used for a particular Type A component. The standard deviation of the mean is  $S_r/N^{1/2}$ , and the total standard deviation of the mean is  $[\sum(S_r^2/N)]^{1/2}$ , where the summation is carried out for all Type A components.

All the Type B components are assumed to be independent and have rectangular or uniform distributions (that is, each has an equal probability of being within the region,  $\pm\delta_s$ , and zero probability of being outside that region). If the distribution is rectangular, the standard deviation,  $\sigma_s$ , for each Type B component is equal to  $\delta_s/3^{1/2}$  and the total 'standard deviation' is  $(\sum\sigma_s^2)^{1/2}$ , where the summation is performed over all Type B components.

The combined uncertainty is determined by combining the Type A and Type B standard deviations in quadrature; the expanded uncertainty is obtained by multiplying this result by a coverage factor of 2. The expanded uncertainty, U, is then

$$U = 2 \sqrt{\sum_s \sigma_s^2 + \sum_r \frac{S_r^2}{N}} \tag{7}$$

The values used to calculate the NIST expanded uncertainty (shown in Tables 1 through 4) are listed in Table 5. The number of decimal places used in reporting the mean values of the correction factor were determined by expressing the expanded NIST uncertainty to two significant digits.

**Type A**

Repeatability: This is an uncertainty due to the scatter of data points around the measurement average obtained from three calibration runs on the OFPM being calibrated.

**Type B**

a. Laser power stability: During the nonlinearity calibration of an OFPM, changes in optical power such as drift or fluctuations can cause a possible error. The power stability is measured during the time interval in which the three

Folder No. & NISTID: 26000 & 81300  
 Date of Report: April 30, 2000  
 Reference: P.O. No. 2121 04/15/00

## OPTICAL POWER METER

Meter's Manufacturer

Model Number, Serial Number

with Sensors

Model Number X, Serial Number 1

Model Number Y, Serial Number 2

measurements are taken. The low power (when an individual shutter is open) is measured before and after the high power (when both shutters are open). The value for laser stability is found by measuring the drift for each laser source. The slope of the drift (percent per second) is then multiplied by the interval that the three shutters are open (3 s) during an actual nonlinearity calibration. The maximum measured value of the power drift is 0.21 % at 850 nm, and 0.09 % at 1300 nm and 1550 nm. The standard uncertainty for laser stability is  $0.21/(2\sqrt{3}) = 0.06$  % at 850 nm, and  $0.09/(2\sqrt{3}) = 0.03$  % at 1300 nm and 1550 nm.

b. Polynomial truncation: The conversion function of an OFPM is a least-squares fit to a third-order polynomial. The uncertainty is due to truncation of the polynomial of higher orders. The maximum value of the error is equal to 0.007 %. The standard uncertainty is  $0.007/(2\sqrt{3}) = 0.002$  %.

c. Test meter spectral responsivity: This uncertainty is caused by drift of the source wavelength and a drift of the optical spectrum analyzer during each triplet measurement. The size of the uncertainty depends on the absorbing material of the power meter detector. The value is estimated based on the spectral responsivity curves for Si, Ge, and InGaAs detectors. We assume a combined variation for the lasers wavelengths and accuracy of the optical spectrum analyzer of 0.1 nm.

d. Equation approximation: This uncertainty is due to the approximation in the nonlinearity equation. The uncertainty is of second-order in magnitude, i.e., if the nonlinearity is 1 %, then the uncertainty is  $(0.01)^2$  or  $10^{-4}$ . This uncertainty depends on the value for the nonlinearity in each case. The maximum uncertainty will be divided by  $(2\sqrt{3})$ .

e. Polarization: This uncertainty is due to effects caused by changes in polarization of the incident power during each triplet measurement set. This uncertainty is related to polarization dependent loss (PDL) of the nonlinearity system. Polarization uncertainty of the nonlinearity system is assumed to be small because we take a large number of measurements (810 measurements per one power range) and because measurement time scales are short compared to changes in the system polarization state. The PDL of the nonlinearity system was measured using a random-polarization generator. The maximum value of the system PDL is 0.002 dB or 0.05 %. The standard uncertainty is  $0.05/(2\sqrt{3}) = 0.014$  %.

Table 5 lists typical measurement uncertainties associated with the nonlinearity calibration of an OFPM. The exact value of these various components can change depending on the particular measurement conditions.

Folder No. & NISTID: 26000 & 81300  
Date of Report: April 30, 2000  
Reference: P.O. No. 2121 04/15/00

8 of 10



OPTICAL POWER METER  
 Meter's Manufacturer  
 Model Number, Serial Number  
 with Sensors  
 Model Number X, Serial Number 1  
 Model Number Y, Serial Number 2

Table 5. Typical nonlinearity measurement uncertainties.

Source	Standard uncertainty (type) (%)
Laser stability	
@ 850 nm	0.06 (B)
@ 1300 & 1550 nm	0.03 (B)
Polynomial truncation	0.002 (B)
Test meter spectral responsivity	
@ 850 nm (Si)	0.004 (B)
@ 850 nm (Ge)	0.014 (B)
@ 850 nm (InGaAs)	0.015 (B)
@ 1300 nm (Ge)	0.004 (B)
@ 1300 nm (InGaAs)	0.003 (B)
@ 1550 nm (Ge)	0.027 (B)
@ 1550 nm (InGaAs)	0.001 (B)
Polarization	0.014 (B)
Equation approximation	0.003 (B)
Repeatability (N = 3)	See Tables 1 through 4 (A)
Typical combined uncertainty	0.05
Typical expanded uncertainty (k = 2)	0.10

Folder No. & NISTID: 26000 & 81300  
 Date of Report: April 30, 2000  
 Reference: P.O. No. 2121 04/15/00

OPTICAL POWER METER  
Meter's Manufacturer  
Model Number, Serial Number  
with Sensors  
Model Number X, Serial Number 1  
Model Number Y, Serial Number 2

For the Director,  
National Institute of Standards  
and Technology

Report Reviewed By:

Gordon W. Day, Division Chief  
Optoelectronics Division

Thomas R. Scott, Group Leader  
Sources and Detectors Group  
Optoelectronics Division

Report Reviewed By

Report Prepared/Calibrated By:

Christopher L. Cromer, Project Leader  
Sources and Detectors Group  
Optoelectronics Division

Igor Vayshenker, Electronics Engineer  
Sources and Detectors Group  
Optoelectronics Division

Folder No. & NISTID: 26000 & 81300  
Date of Report: April 30, 2000  
Reference: P.O. No. 2121 04/15/00

10 of 10

## THE SP 250 SERIES ON NIST MEASUREMENT SERVICES\*

SP 250-1	Spectral Radiance Calibrations PB87179883	SP 250-24	Standard Cell Calibrations PB88123690
SP 250-2	Far Ultraviolet Detector Standards PB87227609	SP 250-25	Calibration Service for Inductive Voltage Dividers
SP 250-3	Radiometric Standards in the Vacuum Ultraviolet PB87227625	SP 250-26	NBS Phase Angle Calibration Services PB88225636
SP 250-4	Fricke Dosimetry in High-Energy Electron Beams PB88110374	SP 250-27	AC-DC Difference Calibrations PB892222616
SP 250-5	Alpha-Particle Calibrations PB88168620	SP 250-28	Solid-State DC Voltage Standard Calibrations PB88168703
SP 250-6	Regular Spectral Transmittance PB88108550	SP 250-29	Traceable Frequency Calibrations PB88168364
SP 250-7	Radiance Temperature Calibrations PB88123674	SP 250-30	GOES Satellite Time Code Dissemination: Description and Operation PB88168760
SP 250-8	Spectral Reflectance PB88109905	SP 250-31	Mass Calibrations PB89153894
SP 250-9	Calibration of Beta-Particle-Emitting Ophthalmic Applicators PB88108535	SP 250-32	A Calibration Service for 30 MHz Attenuation and Phase Shift PB88238324
SP 250-10	Radioactivity Calibrations with the "4 $\pi$ " Gamma Ionization Chamber and Other Radioactivity Calibration Capabilities PB88123708	SP 250-33	A Calibration Service for Voltage Transformers and High-Voltage Capacitors PB882252903
SP 250-11	Dosimetry for High Dose Applications PB88201587	SP 250-34	High Vacuum Standard and Its Use PB89193841
SP 250-12	Neutron Personnel Dosimetry PB87227617	SP 250-35	The Calibration of Thermocouples and Thermocouple Materials PB89209340
SP 250-13	Activation Foil Irradiation with Californium Fission Sources PB88217443	SP 250-36	A Calibration Service for Current Transformers PB91216770
SP 250-14	Activation Foil Irradiation by Reactor Cavity Fission Sources PB88217435	SP 250-37	Photometric Calibrations PB97148472
SP 250-15	Photometric Calibrations PB88153747	SP 250-38	NIST Leak Calibration Service PB92149772
SP 250-16	Calibration of X-Ray and Gamma-Ray Measuring Instruments PB88211826	SP 250-39	NIST Pressure Calibration Service PB94164043
SP 250-17	The NBS Photodetector Spectral Response Calibration Transfer Program PB88201595	SP 250-40	Absorbed-Dose Calibration of Ionization Chambers in a <sup>60</sup> Co Gamma-Ray Beam SN003-003-03034-1 \$2.00
SP 250-18	Neutron Source Strength Calibrations PB88211818	SP 250-41	Spectroradiometric Detector Measurements: Part I - Ultraviolet Detectors and Part II - Visible to Near-Infrared Detectors SN003-003-03550-5 \$9.50
SP 250-19	Calibration of Gamma-Ray-Emitting Brachytherapy Sources PB89193858	SP 250-42	Spectroradiometric Detector Measurements: Part III - Infrared Detectors SN003-003-03582-3 \$5.25
SP 250-20	Spectral Irradiance Calibrations PB88123781	SP 250-43	Radiance Temperature Calibrations SN003-003-03511-4 \$10.00
SP 250-21	Calibration of Beta-Particle Radiation Instrumentation PB88201579	SP 250-44	Radiation Processing Dosimetry Calibration Services and Measurement Assurance Program SN003-003-03513-1
SP 250-22	Platinum Resistance Thermometer Calibrations PB88138367		
SP 250-23	Liquid-in-Glass Thermometer Calibration Service PB89128888		

\* Entries containing a stock number (SN003-003-) and price can be purchased from the Superintendent of Documents, U.S. Government Printing Office, Washington, DC 20402-9325. GPO will accept checks, money orders, VISA, and MasterCard. For more information, or to place an order, call (202) 512-1800. Be sure to cite the stock number on all orders.

Entries containing PB numbers can be purchased from the National Technical Information Service, Springfield, VA 22161. NTIS will accept American Express in addition to the payment methods listed for GPO. For more information call (703)487-4650; to place an order call (800) 553-6487. Fax: (703) 321-8547. Be sure to cite the PB number on all orders.

Entries without stock or PB numbers are in preparation.

## THE SP 250 SERIES ON NIST MEASUREMENT SERVICES\* — Continued

- SP 250-45 Radiation Processing Dosimetry Calibration Services: Manual of Calibration Procedures  
SN003-003-03514-9 \$4.00
- SP 250-46 NIST Multifunction Calibration System  
SN003-003-03515-7 \$2.75
- SP 250-47 NIST Calibration Service for Capacitance Standards at Low Frequencies  
SN003-003-03549-1 \$7.00
- SP 250-48 Spectral Reflectance  
SN003-003-03545-9 \$14.00
- SP 250-49 NIST Calibration Services for Gas Flow Meters: Piston Prover and Bell Prover Gas Flow Facilities  
SN003-003-03560-2 \$6.00
- SP 250-51 Calibration Service of Optoelectronic Frequency Response at 1319 nm for Combined Photodiode/rf Power Sensor Transfer Standards  
SN003-003-03623-4
- SP 250-52 Error Analysis and Calibration Uncertainty of Capacitance Standards at NIST
- SP 250-53 Calibration Service for Spectral Responsivity of Laser and Optical-Fiber Power Meters at Wavelengths Between 0.4  $\mu\text{m}$  and 1.8  $\mu\text{m}$   
SN003-003-03624-2
- SP 250-54 Optical Fiber Power Meter Calibrations at NIST
- SP 250-56 Optical Fiber Power Meter Nonlinearity Calibrations at NIST

\* Entries containing a stock number (SN003-003-) and price can be purchased from the Superintendent of Documents, U.S. Government Printing Office, Washington, DC 20402-9325. GPO will accept checks, money orders, VISA, and MasterCard. For more information, or to place an order, call (202) 512-1800. Be sure to cite the stock number on all orders.

Entries containing PB numbers can be purchased from the National Technical Information Service, Springfield, VA 22161. NTIS will accept American Express in addition to the payment methods listed for GPO. For more information call (703)487-4650; to place an order call (800) 553-6487. Fax: (703) 321-8547. Be sure to cite the PB number on all orders.

Entries without stock or PB numbers are in preparation.

# **NIST** *Technical Publications*

## **Periodical**

---

**Journal of Research of the National Institute of Standards and Technology**—Reports NIST research and development in those disciplines of the physical and engineering sciences in which the Institute is active. These include physics, chemistry, engineering, mathematics, and computer sciences. Papers cover a broad range of subjects, with major emphasis on measurement methodology and the basic technology underlying standardization. Also included from time to time are survey articles on topics closely related to the Institute's technical and scientific programs. Issued six times a year.

## **Nonperiodicals**

---

**Monographs**—Major contributions to the technical literature on various subjects related to the Institute's scientific and technical activities.

**Handbooks**—Recommended codes of engineering and industrial practice (including safety codes) developed in cooperation with interested industries, professional organizations, and regulatory bodies.

**Special Publications**—Include proceedings of conferences sponsored by NIST, NIST annual reports, and other special publications appropriate to this grouping such as wall charts, pocket cards, and bibliographies.

**National Standard Reference Data Series**—Provides quantitative data on the physical and chemical properties of materials, compiled from the world's literature and critically evaluated. Developed under a worldwide program coordinated by NIST under the authority of the National Standard Data Act (Public Law 90-396). NOTE: The Journal of Physical and Chemical Reference Data (JPCRD) is published bi-monthly for NIST by the American Chemical Society (ACS) and the American Institute of Physics (AIP). Subscriptions, reprints, and supplements are available from ACS, 1155 Sixteenth St., NW, Washington, DC 20056.

**Building Science Series**—Disseminates technical information developed at the Institute on building materials, components, systems, and whole structures. The series presents research results, test methods, and performance criteria related to the structural and environmental functions and the durability and safety characteristics of building elements and systems.

**Technical Notes**—Studies or reports which are complete in themselves but restrictive in their treatment of a subject. Analogous to monographs but not so comprehensive in scope or definitive in treatment of the subject area. Often serve as a vehicle for final reports of work performed at NIST under the sponsorship of other government agencies.

**Voluntary Product Standards**—Developed under procedures published by the Department of Commerce in Part 10, Title 15, of the Code of Federal Regulations. The standards establish nationally recognized requirements for products, and provide all concerned interests with a basis for common understanding of the characteristics of the products. NIST administers this program in support of the efforts of private-sector standardizing organizations.

*Order the following NIST publications—FIPS and NISTIRs—from the National Technical Information Service, Springfield, VA 22161.*

**Federal Information Processing Standards Publications (FIPS PUB)**—Publications in this series collectively constitute the Federal Information Processing Standards Register. The Register serves as the official source of information in the Federal Government regarding standards issued by NIST pursuant to the Federal Property and Administrative Services Act of 1949 as amended, Public Law 89-306 (79 Stat. 1127), and as implemented by Executive Order 11717 (38 FR 12315, dated May 11, 1973) and Part 6 of Title 15 CFR (Code of Federal Regulations).

**NIST Interagency Reports (NISTIR)**—A special series of interim or final reports on work performed by NIST for outside sponsors (both government and nongovernment). In general, initial distribution is handled by the sponsor; public distribution is by the National Technical Information Service, Springfield, VA 22161, in paper copy or microfiche form.