

**NATIONAL WEATHER SERVICE MANUAL 10-942**  
**FEBRUARY 10, 2010**

**Operations and Services**  
**Hydrologic Services Program, NWSPD 10-9**  
**FLOOD WARNING SYSTEMS MANUAL**

---

**NOTICE:** This publication is available at: <http://www.nws.noaa.gov/directives/>

---

**OPR:** W/OS31 (J. Bradley)

**Certified by:** W/OS3 (T. Graziano)

**Type of Issuance:** Routine.

---

**SUMMARY OF REVISIONS:** This directive supersedes NWS Manual 10-942, "Flood Warning Systems Manual," dated November 29, 2005. The following revisions were made to this manual:

- 1) Modifies Section 2.5 to delete specific references to AFWS grants.
- 2) Modifies Section 3.7 to add a reference to the ongoing transition activities from the IFLOWS web site to the AFWS web site.
- 3) Modifies Section 3.8 to add a reference to the new AFWS program activity and delete references to the old IFLOWS program activities.
- 4) Adds Section 3.9: AFWS Web Site.
- 5) Adds Section 3.10: AFWS Connectivity.
- 6) Modifies Section 4.4 to delete specific references to AFWS grants.
- 7) Modifies Section 4.8 to delete the reference to the GMF.
- 8) Modifies Section 5.2 to include a reference to NDS 1-1201.
- 9) Modifies the link in Section 5.2 to the CFO web site, which provides agency information on Memorandum of Agreements.
- 10) Modifies Appendix A to include language covering data access rights.
- 11) Deletes Appendix D: AFWS Grant Application Guide.
- 12) Simplifies the figure numbering system in the appendices.
- 13) Updates e-mail addresses throughout the entire document.
- 14) Updates hyperlinks throughout the entire document.

(Signed)

January 26, 2010

---

David B. Caldwell  
Director, Office of Climate,  
Water, and Weather Services

Date

Table of Contents.....	Page
<b>Chapter 1 Introduction to Flood Warning Systems .....</b>	<b>1</b>
1.1 Purpose .....	1
1.2 Concept.....	1
1.3 Benefits.....	1
1.4 Costs .....	2
<b>Chapter 2 Automated Flood Warning System Planning.....</b>	<b>3</b>
2.1 General Planning .....	3
2.2 Design Cost Estimates .....	3
2.3 Procurement Cost Estimates.....	4
2.4 Operation and Maintenance Cost Estimates.....	5
2.5 Grant Funding.....	6
2.6 Alternate Uses .....	6
2.7 Documentation .....	6
2.8 Backup System.....	6
<b>Chapter 3 Technical Information.....</b>	<b>8</b>
3.1 Radio Reporting Rain Gages .....	8
3.2 Rain Gage Selection Factors .....	9
3.3 Stream Gages.....	9
3.4 Communications Media.....	10
3.5 Software.....	10
3.6 Automated Local Evaluation in Real Time (ALERT) Configuration .....	11
3.7 Integrated Flood Observing and Warning System (IFLOWS) Configuration .....	12
3.8 IFLOWS Technical Support at NWS Offices .....	13
3.9 IFLOWS Technical Support at NWS Offices .....	13
3.10 Getting Data on the New AFWS Website.....	13
<b>Chapter 4 Transmitter Licenses.....</b>	<b>15</b>
4.1 Federal and Non-Federal Licensing .....	15
4.2 Hydrologic Frequencies.....	15
4.3 Transmitter Narrowband Compliance .....	15
4.4 Existing Licenses.....	16
4.5 Applying for an FCC License.....	16
4.6 License Renewal.....	18
4.7 Responsibility of Licensee .....	18
4.8 Special Procedures for Transitioning Licenses from NWS to non-NWS Entities .....	18
<b>Chapter 5 Memorandum of Agreement .....</b>	<b>20</b>
5.1 Uses for an Agreement .....	20
5.2 Critical Agreement Requirements .....	20
5.3 Signatories .....	21
<b>Appendix A General Memorandum of Agreement .....</b>	<b>A-1</b>
<b>Appendix B Guide for Obtaining an FCC License on Hydrologic Radio Frequencies.....</b>	<b>B-1</b>
1. Introduction .....	B-1

- 1.1 Overview .....B-1
- 1.2 Frequencies Available For Use .....B-1
- 1.3 Configuring Web Browsers.....B-2
- 2. Licensing Process .....B-2
  - 2.1 New Applicants .....B-2
  - 2.2 Requesting New Licenses.....B-2
  - 2.3 Phase I - Collect All Pertinent Information For Each License Required .....B-3
  - 2.4 Phase II - Enter All Information Collected From Phase I Into The ULS .....B-3
    - 2.4.1 Application Information Tab .....B-4
    - 2.4.2 Applicant Tab .....B-5
    - 2.4.3 Ownership/Qualification Questions Tab .....B-6
    - 2.4.4 General Certification Statements Tab .....B-7
    - 2.4.5 Control Point Tab .....B-8
    - 2.4.6 Administrative Tab.....B-9
    - 2.4.7 Location Tab.....B-10
    - 2.4.8 Antenna Tab .....B-11
    - 2.4.9 Frequency Tab .....B-12
  - 2.5 Phase III - Submit Exported ULS Information for Federal Approval.....B-13
  - 2.6 Phase IV - Complete and File The ULS Application .....B-13
- 3. Modifying Existing Licenses.....B-14
  - 3.1 Phase I - Determine the Type of Modification .....B-15
  - 3.2 Phase II - Create a Modification Application in the ULS .....B-15
  - 3.3 Phase III - Enter License Modifications Into The ULS.....B-15
    - 3.3.1 Application Information Tab .....B-16
    - 3.3.2 Applicant Tab .....B-17
    - 3.3.3 Ownership/Qualification Tab .....B-18
    - 3.3.4 General Certification Tab .....B-19
    - 3.3.5 Control Point Tab .....B-20
    - 3.3.6 Administrative Tab .....B-21
    - 3.3.7 Location Tab.....B-22
    - 3.3.8 Antenna Tab .....B-23
    - 3.3.9 Frequency Tab .....B-24
  - 3.4 Phase IV - Submit Exported ULS Information for Federal Approval.....B-25
  - 3.5 Phase V - Complete and File the ULS Application.....B-25
- 4. Renewing Existing Licenses.....B-25
  - 4.1 Canceling An Existing License .....B-25
- 5. Glossary .....B-25

**Appendix C Sample Letter to AFWS Owner Indicating Need to Obtain FCC License ...C-1**

**Appendix D Response Planning Guidance ..... D-1**

- 1. Introduction ..... D-1
- 2. Warning Dissemination ..... D-1
  - 2.1 Warning Dissemination Identification Task..... D-1
  - 2.2 Warning Dissemination Procedures Development Task ..... D-1
- 3. Evacuation and Rescue..... D-1
  - 3.1 Evacuation Area Identification Task ..... D-2
  - 3.2 Evacuation Procedures Development Task ..... D-2

3.3	Reception Center Operations Task.....	D-3
3.4	Emergency Action Task.....	D-3
4.	Damage Reduction Element.....	D-4
4.1	Flood-Fighting Task.....	D-4
4.2	Utility Management Task.....	D-4
4.3	Traffic Control Task.....	D-5
4.4	Maintenance of Vital Services Task.....	D-5
5.	Recovery Element.....	D-6
5.1	Maintenance of Public Health Task.....	D-6
5.2	Return of Services Task.....	D-6
5.3	Rehabilitation and Repair Task.....	D-6
6.	Public Information Element.....	D-7
6.1	Community Education Task.....	D-7
6.2	Emergency Information Task.....	D-8
7.	Plan Implementation Element.....	D-8
7.1	Resource Identification Task.....	D-8
7.2	Responsibility Allocation Task.....	D-9
7.3	Coordination Task.....	D-9
8.	Plan Maintenance.....	D-10
8.1	Plan Updating Task.....	D-10
8.2	Plan Improvement Task.....	D-10
8.3	Plan Practice Task.....	D-11
<b>Appendix E ALERT Format.....</b>		<b>E-1</b>
1.	Introduction.....	E-1
2.	ALERT/IFLOWS Data Formats.....	E-1
<b>Appendix F Gage Maintenance Primer.....</b>		<b>F-1</b>
1.	Sensor Cleaning and Clearing Problems.....	F-1
2.	Preparing for a Visit to a Gage.....	F-1
3.	Tools.....	F-2
4.	Arriving at a Site.....	F-3
5.	Taking Apart the Gage.....	F-4
6.	Cleaning the Tipping Bucket.....	F-5
7.	Leveling the Tipping Bucket.....	F-7
8.	Final Steps.....	F-7
9.	Electronic Component Servicing.....	F-7
<b>Appendix G Selected References.....</b>		<b>G-1</b>

## Chapter 1 Introduction to Flood Warning Systems

### 1.1 Purpose

Both the National Weather Service (NWS) and the emergency management community recognize the importance of flood warning systems (FWS) for protecting lives and livelihoods. Communities across the country have created FWS to warn areas of flood danger, and to provide NWS with critical rainfall, stream level, and other hydrometeorological data. Nearly all FWS are built and operated using gages and a communications system to collect and distribute information. FWS, however, require a high level of ongoing commitment and support beyond one-time installation costs. Those with the most success have proactive, energetic staff members; strong long term operational funding; and a good rapport with the local NWS forecast office. This manual provides guidance for working with local communities who want to develop, implement, and operate FWS.

### 1.2 Concept

The basic benefit of a local flood warning program is an increased lead time for watches and warnings at locations subject to flood risk. The information can be used to predict whether a flood is about to occur, when it will arrive, and how severe it will be. Organizations and individuals are given notice by the system so they can protect themselves and their property. The basic parts of a flood warning program are:

- The FWS, including equipment, people, and procedures for recognizing an impending flood and disseminating warnings
- A prepared plan of action to be taken before and during the flood
- Arrangements for updating and maintenance of equipment and plans

Local flood warning programs can be extremely effective. Those now in use have been credited with saving scores of lives and preventing millions of dollars of damage. They are most valuable where flooding occurs very quickly following heavy rains. Local flood warning programs also have been credited with preventing unnecessary evacuations and other overreactions in cases when floods threatened but did not occur. Thousands of communities that are threatened by floods lack the elementary protection of a flood warning program despite the many success stories, the relatively low cost for their development, and the simplicity of their operation. NWS can play an important role in promoting local flood warning systems by providing technical support, maintaining regular communications and feedback, and working with community officials on outreach and education programs about the risk from flooding.

### 1.3 Benefits

While relying on NWS forecasts for generalized information, communities can reduce risks by establishing local flood warning programs. Timely collection of more detailed information on local rainfall and stream levels allows more accurate and reliable predictions of floods. Advance knowledge about an impending flood can be used to:

- Warn low-lying areas to evacuate
- Schedule closure of schools and transportation of students
- Curtail electric and gas service to prevent fire and explosions

- Provide evacuation assistance to invalids, convalescents and others requiring help;
- Establish traffic controls to facilitate evacuation and prevent inadvertent travel into hazardous areas
- Deploy fire and rescue services for continued protection

When enough time is made available by a local flood warning system, it can also often be put to use to reduce property damage including:

- Moving vehicles and equipment from low areas
- Relocating or stacking contents of private structures
- Shutting down motors and pumps to prevent damage
- Initiating flood fighting efforts
- Establishing security to prevent looting

#### 1.4 Costs

The costs to develop, operate, and maintain systems will vary greatly, and are discussed in detail in Chapter 2. One major cost factor is whether to use manual or automatic gages. Manual gages are relatively inexpensive to purchase and maintain, but labor intensive to operate. By contrast, automatic gages (Figure 1-1) are usually more expensive to buy and maintain, but do not require any labor to collect and report data. Manual gages require a person to travel to the site, read the data, and report the readings to NWS and emergency operations centers. Automatic gages offer several advantages over manual gages, including:

- Ability to provide information from places and at times when people are unavailable
- Ability to report information almost instantaneously
- Ability to communicate during severe weather, when other communications channels may become unavailable
- Uniform standards for data collection and reporting

Because of these advantages, the automatic rain gage is preferred by many system operators. Automatic gages, along with their associated communications and computer software, are called Automated Flood Warning Systems (AFWS). Although manual gages should be considered by flood warning system planners, the remainder of this document will focus upon AFWS.



**Figure 1-1.** Automatic rain gage.

## Chapter 2 Automated Flood Warning System Planning

### 2.1 General Planning

The objective of an AFWS is to increase the amount of warning time given to people who may be affected by rising waters in flood-prone areas. Success depends on good planning—knowing what areas are the most vulnerable; what sensor locations will best serve the vulnerable areas, and what type and frequency of measurements are needed. Success also depends on recognizing practical limitations that affect both startup and operational costs. Factors that will generally increase costs include the number of sensor types and locations, site accessibility, equipment accuracy, reporting frequency, number of operational locations where reports are needed, and redundancy requirements. Communities often use a combination of local resources, NWS support, and private consultants to develop and document a system design. NWS staff is encouraged to collaborate with communities developing AFWS, especially in selecting sites and assuring that NWS will receive data that it can ingest into its Advanced Weather Information Processing System (AWIPS). NWS staff should also make efforts to provide ongoing feedback to the AFWS system owner on the usefulness and dependability of data being provided. One of the first steps in the AFWS planning process is to gather general information about AFWS. The National Hydrologic Warning Council (NHWC) website, [www.hydrologicwarning.org](http://www.hydrologicwarning.org), is an excellent source of information related to AFWS. NHWC members include the ALERT Users Group (AUG), the Southwestern Association of ALERT Systems (SAAS), and the ALERT/IFLOWS users group. Many AFWS users also participate in the Yahoo Groups “Floodsystems” bulletin board, and will answer questions that are posted at this site.

### 2.2 Design Cost Estimates

Most AFWS are configured with three major components: (1) data collection (gages); (2) data processing (computer and software); and (3) information dissemination. The most significant AFWS design cost factor is the number of gage site locations—the more sites there are, the more the AFWS will cost. Unfortunately, it is difficult to quickly estimate an average cost per site, because the site costs are strongly influenced by communications. Each gage site sends information to a collection point, but gage physical locations may limit the choices of how the messages can be sent. In addition, each communications medium has physical properties that can be “good” or “bad”, depending on the system requirements. This makes it very important in the early planning process to evaluate the pros and cons of each type of communications medium, and decide which ones best meet operational requirements and budget limitations.

Aside from physical locations, other important factors that influence the choice of communications media are: how dependent is the medium on local communications infrastructure which might fail or become clogged with traffic during severe weather; are there limits on how often the medium sends reports; is it necessary for the medium to handle large quantities of data (broadband capability); and is the medium capable of providing diagnostic reports or other performance information.

Communications media fall into two general categories—contract and owner-operated. Contract media are usually provided by telecommunications companies that charge monthly fees, establish minimum performance standards, and provide a level of built-in maintenance support. Examples of contract media are telephone systems (both cellular and land-based), cable, DSL,

and satellite. Owner-operated media are systems in which the owner assumes full responsibility for communications equipment operation and licensing, but does not incur a monthly fee from a service provider. Owners are often governmental entities, who sometimes pool communications resources. Examples of owner-operated communications media are microwave radio networks, radio reporting gages, wireless local area networks, and directly connected wiring. Table 1 below summarizes common communications media and properties for each. It is very general, and is meant only to provide an overview. AFWS planners should obtain more specific information from NWS, vendors, and other government agencies to develop an accurate cost estimate for system installation and ongoing maintenance. Funding for AFWS systems is usually through the local tax base.

Communications Medium	Availability for Sites In Remote Areas	Dependence on Local Infrastructure	Broadband (High-Volume ) Capability	Near-Real Time Data Available?	Network Health Reported to Customer	Installation Costs	Recurring Communications Charges
<b>CONTRACTED SERVICES</b>							
Telephone (wired network)	Poor	High	No	On demand	No	Low	Fixed monthly
Telephone (cellular)	Fair	Medium	No	Yes	No	Low	Fixed and usage-based
Cable/DSL	Poor	High	Yes	Yes	No	Low	Fixed monthly
Two-Way Satellite (Internet network)	Good	Low	Yes	Yes	No	Medium	Fixed monthly
Two-Way Satellite (private network)	Good	Low	No	Yes	Yes	Medium	Fixed and usage-based
NOAA GOES	Good	Low	No	Sometimes	No	Medium	None
<b>OWNER-OPERATED MEDIA</b>							
VHF/UHF Radio	Good	Low	No	Yes	N/A	Medium	None
Microwave Radio	Fair	Low	No	Yes	N/A	High	Not usually
Wireless LAN	Poor	Low	Yes	Yes	N/A	Low	None
Direct Wire	Poor	None	Yes	Yes	N/A	Low	None

Table 1 Communications Media

### 2.3 Procurement Cost Estimates

Early in the process, AFWS planners have to decide how much of the design, implementation, and operation phases will be contractor versus owner-operated. Like the communications media choices described above, there is no “best” answer. Fee-based providers can perform tasks ranging from limited design and software support to turnkey operational management. Similar tasks may also be performed by in-house staff, partnering agencies, and volunteer organizations at lower costs, but with higher levels of coordination required. AFWS planners should discuss



these options with current AFWS owners to get a diverse range of opinions. Examples of partnering agencies that may be able to pool resources are listed in Table 2.

FEDERAL AGENCIES	WEB SITES
U.S. Army Corps of Engineers	<a href="http://www.usace.army.mil/">http://www.usace.army.mil/</a>
U.S. Bureau of Reclamation	<a href="http://www.usbr.gov/">http://www.usbr.gov/</a>
Natural Resources Conservation Service	<a href="http://www.nrcs.usda.gov/">http://www.nrcs.usda.gov/</a>
U.S. Geological Survey	<a href="http://www.usgs.gov/">http://www.usgs.gov/</a>
Tennessee Valley Authority	<a href="http://www.tva.gov/">http://www.tva.gov/</a>
Federal Emergency Management Agency	<a href="http://www.fema.gov/">http://www.fema.gov/</a>
National Park Service	<a href="http://www.nps.gov/index.htm">http://www.nps.gov/index.htm</a>
NON-FEDERAL AGENCIES	
State/county transportation departments	
State/county police/fire/EMA	
Association of State Floodplain Managers	<a href="http://www.floods.org/">http://www.floods.org/</a>
National Hydrologic Warning Council	<a href="http://www.hydrologicwarning.org/">http://www.hydrologicwarning.org/</a>
ALERT Users Group	<a href="http://www.alertsystems.org/">http://www.alertsystems.org/</a>
Southwest Association of ALERT Systems	
ALERT/IFLOWS	

Table 2 Coordination Agencies

## 2.4 Operation and Maintenance Cost Estimates

The importance of long-term operations and maintenance (O&M) cannot be underestimated. Too often, systems are planned, built, and installed with inadequate O&M support. Within a few months to a few years, poorly managed systems will begin to report unreliably. When this happens, users lose confidence in the information and the investment in the AFWS effort is wasted. Often, it takes more resources to restore adequate performance to a poorly-maintained system than it would have if it had not been allowed to deteriorate. Cost planning for a good O&M program has to cover all elements of the AFWS: gages, communications media, software and computer, outreach, preparedness and response, and, most importantly, sound administrative management of the O&M budget. Generally, the greatest demand on O&M resources is the travel time to remote gage sites. Although AFWS equipment is built to withstand rugged conditions and has a long life span, all environmental sensors are subject to the harshness of nature. Even simple things like insects, pollen, bird droppings, and fallen leaves will have profound effects upon gage performance, and gage cleaning has to be continuously addressed. Preventive maintenance schedules should be established and followed for each type of hardware component. Along with equipment O&M, AFWS users should be continuously trained and

updated on their roles and responsibilities. Conducting practice drills routinely with the NWS has been valuable in maintaining a high-level of system readiness. The AFWS owner has to prepare for life cycle, equipment replacement. The most expensive components (gages and communication equipment) have maintainable life spans of 10-15 years, but the life cycle of associated subcomponents, such as batteries, gage tipping buckets, solar panels, and antennas are much shorter. A very rough rule of thumb is to assume that annual O&M will cost 10%-15% of the initial system costs. Further O&M information is provided elsewhere in this manual.

## 2.5 Grant Funding

Private foundations, state agencies, and Federal agencies (including NOAA) make grant funding available for a variety of purposes, including hazard mitigation and flood warning. The Federal Government has consolidated its grant funding information at the [www.grants.gov](http://www.grants.gov) website.

## 2.6 Alternate Uses

Although AFWS are designed to collect rainfall and stream level data, the same technology and communications systems can be used to convey other types of data, usually with a small incremental cost. AFWS planners should consider partnerships with commercial businesses, public utilities, and State, Federal, and local agencies to share the costs and benefits of data collection. Government agencies responsible for highway safety and maintenance, pollution control, homeland security, and water management may be willing to participate. Likewise, public utilities and commercial enterprises with property, personnel, and operations in flood prone areas are potential partnership candidates. Aside from the obvious benefits of data collection, a broader base of participants can create efficiencies of scale that demonstrate taxpayer funds are being spent conservatively and wisely; while providing a larger baseline constituency for support.

## 2.7 Documentation

Along with technical documentation, AFWS planners should consider the following documents as essential requirements for a successful flood warning system:

- Memorandum of Agreement between the AFWS owners and NWS describing each participating party's support. (See Chapter 5, page 20, for detailed information.)
- Transmitter licenses issued by the Federal Communications Commission (FCC) for each communications site that requires a radio transmitter. (See Chapter 4, page 15.).
- Preparedness plans that integrate automated data collection with elements of education, public information, and response and recovery. Appendix D provides an outline for a community preparedness plan.

## 2.8 Backup System

To ensure the integrity of its local flood warning effort, the AFWS owner-operator should maintain an auxiliary power supply (i.e., uninterruptible power supply or generator) and a backup data collection capability. Backup capability includes necessary redundancies to assure key data in the system will be available at all times. Where such backup cannot be automated, it may be necessary to establish a network of observers to report rainfall and river stages when the automated system is not functioning. Although circumstances vary, many areas of the country

have found computerized backup to be less expensive and more reliable than maintaining an auxiliary network of observers.

## Chapter 3 Technical Information

### 3.1 Radio Reporting Rain Gages

Gages have two primary functions—sensing and communicating. Sensing involves detection of an “event”, which is the smallest unit of measurement desired, such as 1 millimeter of rain, 1/100 inch of stage height, etc. Communicating involves reporting the event to a user location. For maximum flexibility, nearly all gages are designed to allow multiple sensors at a particular site to report through a single communications platform. The gage assigns a unique identifier to each individual sensor type (rain, stream, temperature, wind speed, etc.), and communicates both. Gage manufacturers have implemented many techniques, both proprietary and open-source, for both sensing and communicating. In some cases other information such as time of day, system health, and other site specific information is also conveyed.

One of the most common gages is the radio-reporting gage (RRG) shown in Figure 3-1. The RRG is a VHF or UHF communications transmitter with connectors that allow it to interface with one or more sensors. The RRG converts sensor events into data that can be sent by radio and interpreted as measurements at the processing site. The most common RRG use the Automated Local Evaluation in Real Time (ALERT) data protocol, and are often called ALERT gages. A slight variation to this protocol was developed for the NWS IFLOWS, which is implemented in much of the northeastern US. For most applications, the terms IFLOWS gages and ALERT gages are interchangeable. More information about the ALERT protocol can be found in Appendix F.

Because RRG are often needed in remote areas where commercial power is unavailable, they are usually battery powered with a solar panel recharging system. A common RRG implementation is the 1 millimeter tipping bucket ALERT gage, shown in Figure 3-1.

When 1 millimeter of rain fills the RRG hinged bucket through the top opening of the funnel, the bucket tips, spilling the water and tripping a switch that activates the ALERT data transmitter. The tipping action also resets the bucket, readying it for the next millimeter of rain. The same ALERT gage that reports rainfall can also be interfaced with other sensors to sense and communicate stream level, wind speed and direction, barometric pressure, temperature, relative humidity, water quality, and soil moisture. ALERT gages are designed to report a “no rain” event at least once per day as a “health” check. Alternatively, they can be programmed to report battery voltage for remote diagnosis and monitoring.

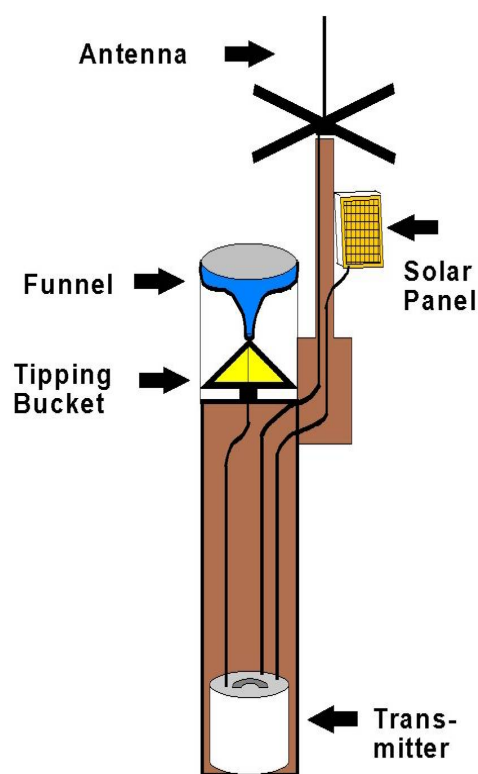

**Figure 3-1.** Radio Reporting Rain Gage.

### 3.2 Rain Gage Selection Factors

Generally, the performance of an AFWS improves as the number and density of gages increase. Increasing the gage density over a given area will increase the likelihood of detecting flood-producing rainfall. The number and placement of gages, however, depends on the rainfall variability and local geography. More gages will be needed over mountainous areas compared to the number needed in flat lands. Areas subject to local, convective storms require more gages than areas experiencing a higher frequency of non-convective precipitation. AFWS planners should collaborate with emergency management officials and the NWS to identify problem areas and how they can best be served by gage sites.

When selecting proposed gage sites, planners should choose one or more backup sites that will provide information for the same area. Installing a gage requires permission from the property owner; clearance of nearby obstructions; and in the case of radio reporting gages, a clear radio path to the destination receiver. By choosing several alternate sites, AFWS planners can assure that requirements will be met if the primary site proves to be unsuitable.



**Figure 3-3.** Well sited gage.



**Figure 3-2.** Obstructed gage.

Rain gages should be placed on the ground, in locations that are uniformly exposed in all directions, such as an opening in a grove of trees (Figure 3-3). The gage has to be positioned away from trees, buildings and other obstructions that may cause erratic airflow affecting the gage catch (Figure 3-2). Likewise, airflow will adversely affect gages in wide-open spaces and elevated sites. If a gage has to be located near an object, then the distance between the gage and the object should be at least twice the height of the object. More guidance on this topic is available in the World Meteorological Organization's Guide to Meteorological

Instruments and Methods of Observation ([http://www.wmo.int/e-catalog/detail\\_en.php?PUB\\_ID=509&SORT=N&q=instruments](http://www.wmo.int/e-catalog/detail_en.php?PUB_ID=509&SORT=N&q=instruments)).

Planners can quickly evaluate the viability of radio communications for many sites using commercial software that has a built-in terrain elevation database. If only a few sites are required, local technicians and radio users may be able to provide advice. If doubt persists, system planners should conduct field tests with portable radio transceivers to measure signal strength between proposed communications points.

### 3.3 Stream Gages

In small watersheds, typical of those associated with AFWS, streamflow observations are used to calibrate watershed models, verify forecasts from models, or trigger alarms when flooding is impending or occurring. The placement of stream gages in an AFWS is guided by public warning requirements and forecast model requirements. Gages used for stage alarms should be

located at key points of potential damage and at points that are far enough upstream to yield enough warning time for downstream locations.

### 3.4 Communications Media

Most VHF/UHF radio-based communications platforms use the ALERT radio transmission protocol, which transmits in real time when each sensor event occurs. ALERT systems are fast, have good resolution, and low operating costs, but they have a limited transmission range. If the distance or terrain between the RRG and the receiving site prevents the signal from being received reliably, a “repeater” can be used to extend the range. The repeater is a specialized transmitter that receives an incoming signal, waits until the entire signal has been received, and retransmits it. It is usually placed at a high elevation, midway between the RRG and the processing site. Transmission distances can also be extended by using existing microwave radio systems. A microwave system is a series of cascaded repeater transceivers that are capable of carrying many independent channels at the same time over long distances. They are most commonly used by law enforcement and public safety agencies, and may be available for use by AFWS owners at a small incremental cost.

Despite their advantages, ALERT gages and other forms of radio transmissions are susceptible to interference from man-made electrical noise, atmospheric conditions, and other transmitters on the same or adjacent frequencies. Because multiple ALERT transmitters share common radio frequencies, there are instances when simultaneous transmissions occur. Satellite data collection platforms and cellular data networks are alternatives to owner-operated ALERT VHF radio transmission networks. Such networks take advantage of newer technology, making them less susceptible to interference, and easy to configure. Satellite platforms typically require an unobstructed view of the southern sky, enabling site locations to be established with a minimum of design effort. Likewise, cellular platforms typically operate from locations served by the provider’s voice network, and can be effectively established. Service providers often include licensing and network monitoring in their fee structure, but often charge proportionally according to the amount of data traffic. Potential risk factors with satellite networks include delays in data delivery (depending on the network); and disruptions due to solar activity, planetary alignment, or atmospheric conditions. Potential risk factors for cellular networks may include denial of service during extreme traffic loading situations or outages related to severe weather.

In instances where broadband Internet is available, devices are available that will convert serial data streams, including ALERT data, into internet packets (IP). These packets can be sent securely via the Internet, and may be a cost-effective backup method for providing primary or backup data feeds.

### 3.5 Software

The primary function of AFWS software is to collect and interpret raw data sent from remote gage locations. Most software also includes one or more applications that enable the user to view the data as graphical or text information, both locally and on the internet. The National Hydrologic Warning Council maintains a website at [www.hydrologicwarning.org](http://www.hydrologicwarning.org) that provides links to manufacturers of flood warning system software and hardware.

In the 1980's, NWS developed software under the IFLOWS program to distribute to eligible AFWS owner-operators in the IFLOWS program. The software has been used by AFWS owner-operator networks in KY, NC, NY, PA, TN, VA, and WV; and at many Weather Forecast Offices (WFO) and River Forecast Centers (RFC) with forecast responsibilities in these states. The AFWS Program Leader (NWS Office of Climate, Water and Weather Services) continues to provide contract support to NWS WFO/RFC that use IFLOWS software. Software documentation may be found at <http://www.afws.net/ldadsupport.htm>. Requests for support from NWS offices may be made to the AFWS Program Leader. IFLOWS software is no longer being distributed to AFWS owner-operators, nor are any future enhancements expected.

### 3.6 Automated Local Evaluation in Real Time (ALERT) Configuration

ALERT is a common AFWS configuration that consists of automated event-reporting meteorological and hydrologic sensors, communications equipment, and computer software and hardware (Figure 3- 4). ALERT sensors transmit coded radio signals to a base station. If the distance or terrain between the transmitter and the processing site prevents the signal from being received reliably, a radio repeater station can be used to extend the range. The base station, which consists of radio receiving equipment and a micro-processor running ALERT software, collects the coded signals and processes them into meaningful hydrometeorological information.

Processed information can be displayed on a computer screen according to various preset criteria, with both visual and audible alarms activated when these criteria are reached. Most systems have the capability of automatically notifying individuals or initiating other programmed actions when preset criteria are exceeded. Systems typically display both text and graphic information, and can be used in combination with other data to show geospatial flood inundation. A system can consist of more than one base station connected through repeater networks to pass along raw, unprocessed information from one user group to another.

ALERT systems are locally funded and supported. Many systems are owned or maintained by more than one participating organization with each ALERT participant owning or maintaining a small portion of the entire system. The NWS does not typically own any ALERT AFWS equipment. In many cases, local system sponsors have provided equipment to the NWS for use in its field offices to assure NWS receives timely data for its forecasts and warnings.

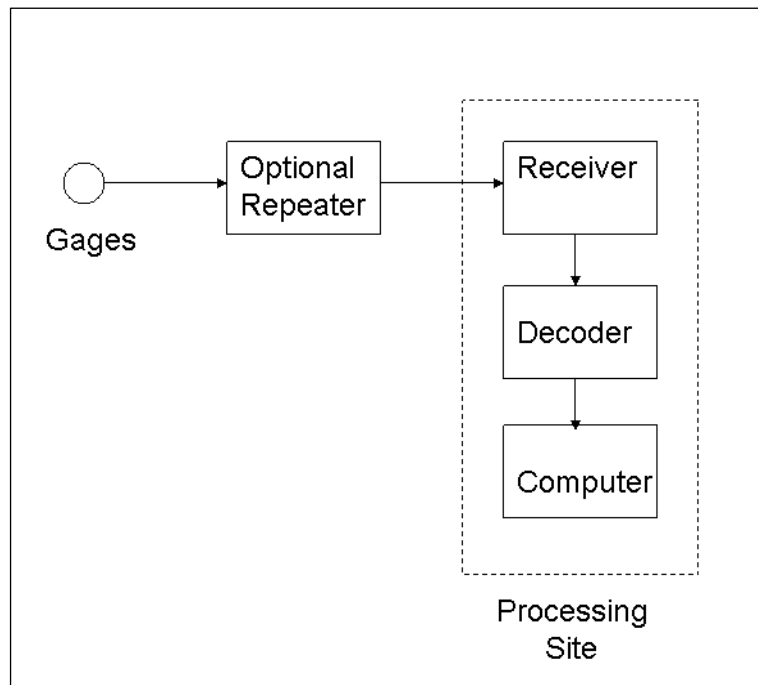

**Figure 3- 4.** ALERT System Configuration.

### 3.7 Integrated Flood Observing and Warning System (IFLOWS) Configuration

IFLOWS was created in the late 1970's to assist flood prone communities in Appalachian states with development of automated flood warning systems. IFLOWS is a cost-sharing partnership between Federal, state, and local government agencies. The NWS provides grant funding assistance to assist in the purchase, enhancement, and refurbishment of AFWS. Most IFLOWS grant funds have been used by AFWS owner-operators in Appalachian states to purchase rain gages. IFLOWS networks currently collect data from over 1000 gages in 200 counties throughout the northeastern US. The website for IFLOWS is <http://www.afws.net>.

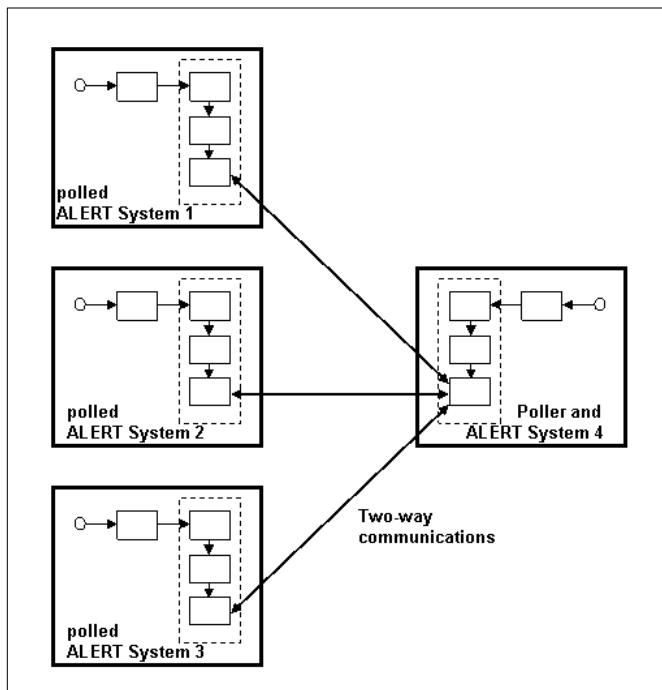

Figure 3- 5. IFLOWS Configuration.

In addition to providing grant funds, the NWS developed “IFLOWS software” during the 1980’s that continues to be used in some networks. IFLOWS software operates as a as a polled network of ALERT-type systems as shown in Figure 3- 5. The IFLOWS software uses a dedicated communications port to exchange data and text information with other locations in the IFLOWS network, using an error-controlled packet data format, sometimes called the “IFLOWS backbone.” One designated polling site per network directs traffic on the backbone, routing data to correct destinations and preventing data packet collisions among the polled stations. Current IFLOWS backbone communications circuits use VHF/UHF radio, microwave, leased telephone lines, satellites, and the Internet to convey data between computers. This

configuration enables each locality that directly receives gages to operate standalone, while enabling it share data with other sites in the network. IFLOWS software also has the ability to display gage data, set alarms, and exchange text messages with other network users.

Many AFWS owner-operators in the northeastern US continue to use IFLOWS software configurations and software in their AFWS. Because IFLOWS is a network-based system, data from IFLOWS is usually available from more than one location. The following list summarizes the locations from which IFLOWS data can generally be obtained:

- AWIPS
- PC in local office
- PC in another office that is part of the state IFLOWS network
- The Internet at [www.afws.net](http://www.afws.net)
- IFLOWS PC at the AFWS owner-operator location

Documentation for IFLOWS software and its interface to AWIPS is found at <http://www.afws.net/ldadsupport.htm>.



This configuration is currently in the process of being modified to the new AFWS configuration described in section 3.9

### **3.8 IFLOWS Technical Support at NWS Offices**

The NWS is transitioning to a new AFWS website at <http://afws.erh.noaa.gov/afws/national.php>. Once this transition is completed, support for IFLOWS related equipment and software at NWS offices will no longer be needed.

### **3.9 New AFWS Website**

The NWS provides limited types of support for ALERT and IFLOWS activities through the NWS AFWS program in the Office of Climate, Water and Weather Services, Hydrologic Services Division (HSD), at NWS headquarters. The AFWS program supports centralized processing of data from ALERT and IFLOWS networks at NWS headquarters. AFWS data are fed to the NWS AWIPS network as well as web servers which provide access to the data at <http://afws.erh.noaa.gov/afws/national.php>. Figure 3- 6 shows the flow of AFWS data from a sensor to the AWIPS network and web servers. An end user's guide for the website can be found at [http://afws.erh.noaa.gov/afws/AFWS\\_End\\_User\\_Guide.pdf](http://afws.erh.noaa.gov/afws/AFWS_End_User_Guide.pdf).

HSD uses a contractor to provide 24/7 operational support to WFO/RFC for the acquisition of AFWS data. Requests for support from NWS offices should be made in advance via email to the AFWS Program Manager in HSD, who will determine whether the request falls under the scope of the support contract. If HSD staff is unavailable, or operational needs require an immediate response, the request may be made directly to the contractor at [afws.cms@noaa.gov](mailto:afws.cms@noaa.gov), with a follow-up email to the HSD AFWS Program Leader.

### **3.10 Getting Data on the New AFWS Website**

Data partners can have their data made available on the AFWS website by following the steps described in the Data Partner Requirements Document at [http://afws.erh.noaa.gov/afws/AFWS\\_Data\\_Partner.pdf](http://afws.erh.noaa.gov/afws/AFWS_Data_Partner.pdf). As covered in that document, a prospective data partner should contact John Bradley, AFWS Program Leader at NWS Headquarters, Office of Climate, Water, and Weather Services via email at [john.bradley@noaa.gov](mailto:john.bradley@noaa.gov) or by phone at (301) 713-0006 ext. 154 for additional information about becoming an AFWS data partner.

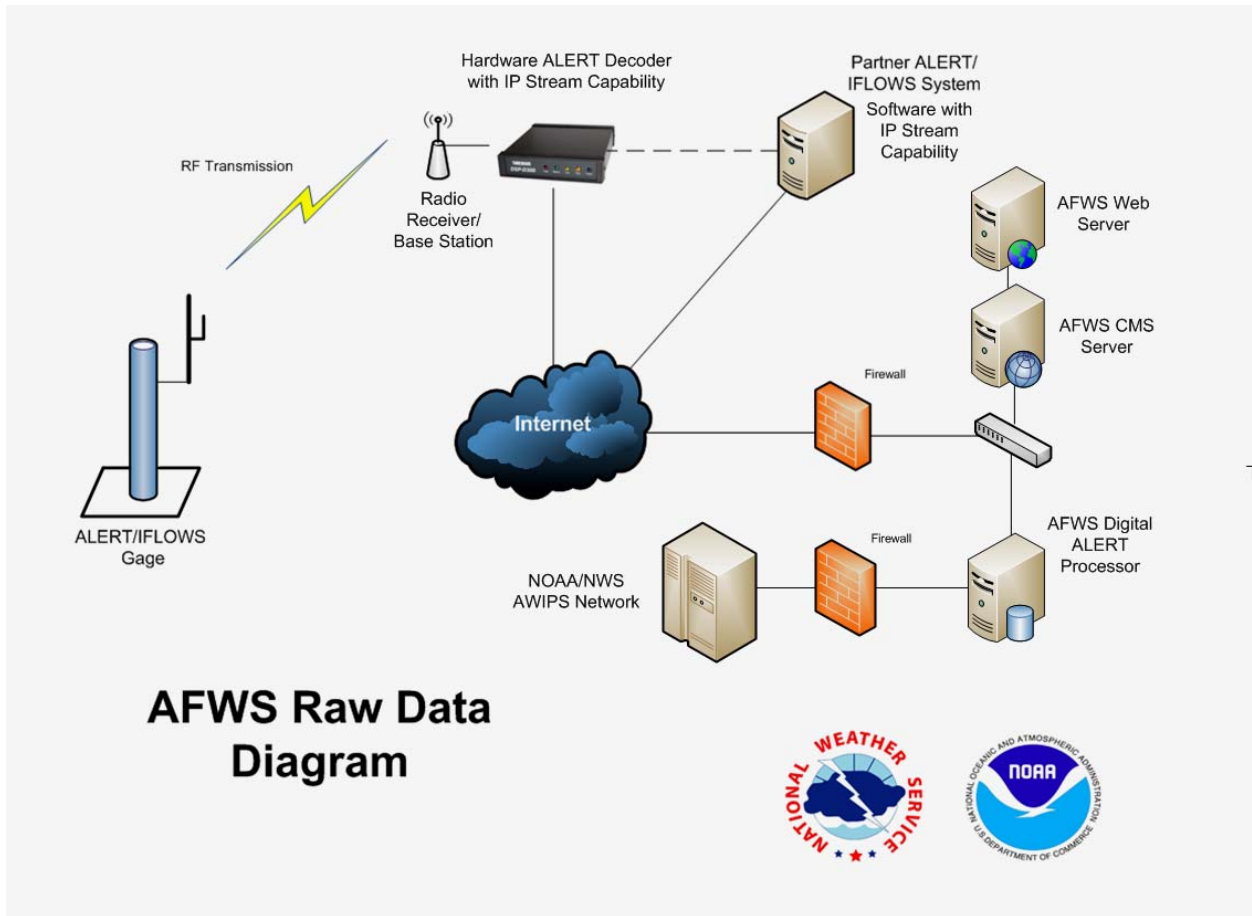

Figure 3- 6. AFWS data path.

## Chapter 4 Transmitter Licenses

### 4.1 Federal and Non-Federal Licensing

Because radio transmitters use public airwaves, they require licenses to legally operate. The license grants the licensee the right to use the frequency; affords a limited amount of protection from interference by others; and holds the licensee accountable for compliance with laws governing radio transmissions. Licenses are issued based on whether the owner/operator of the transmitter is a Federal entity or a non-Federal entity. The Federal Communications Commission (FCC) issues licenses to all non-Federal radio transmitter owners; and the National Telecommunications and Information Administration (NTIA) issues authorizations to all Federal owners. The NWS has no licensing responsibility for AFWS transmitters, nor may it apply for licenses on behalf of non-Federal owner-operators. NWS staff should encourage non-Federal AFWS owners to consult the FCC web site ([www.fcc.gov](http://www.fcc.gov)) and Appendix B to obtain FCC license filing procedures. The FCC uses an Internet-based Universal Licensing System (ULS) that will allow AFWS owners to apply online. Filing consists of providing the FCC with detailed technical information related to the station location and equipment. The FCC makes exceptions for unlicensed operation of very low power transmitters such as wireless local area networks and low power spread spectrum transmissions. If an AFWS purchases services from a commercial satellite service provider, FCC licensing is normally handled by the provider on behalf of the AFWS owner.

When the NWS is clearly the owner-operator of the transmitter, then the NWS will obtain an NTIA license. Local WFOs or RFCs that originate NTIA license requests will do so through each Region's radio frequency coordinator. FCC licenses will be renewed every ten years, and NTIA licenses will be reviewed every five years. Both types will be modified as changes to the station location or transmitter parameters occur.

### 4.2 Hydrologic Frequencies

Appendix B lists Federal government radio frequencies specifically designated for hydrologic use by Federal agencies. Both the FCC and the NTIA have made exceptions to their rules to allow non-Federal AFWS owners to use these Federal government hydrologic frequencies. Use of these "hydrologic frequencies" has become popular with AFWS owners because the channels are often less congested than other non-Federal alternatives. NWS supports the use of these Federal frequencies by AFWS owners in support of the NWS mission. Non-Federal applicants are required to obtain approval to use Federal hydrologic frequencies before submitting transmitter license applications to the FCC. See Appendix B for more detailed licensing information.

### 4.3 Transmitter Narrowband Compliance

Most AFWS transmitters operate in frequencies designated for Federal hydrologic use in the 169-172 MHz band. Effective January 1, 2005 all such transmitters are required to be NTIA narrowband compliant, regardless of whether the licensee is a Federal or non-Federal entity. Narrowband compliance means that the transmitter licensee is required to meet NTIA technical regulations that help to conserve the use of the radio frequency spectrum. Although new AFWS transmitters are typically narrowband compliant, some AFWS may be using older, outdated transmitters that do not comply. NWS staff should advise its AFWS partners of their obligation

to comply with these rules, and encourage them to upgrade their equipment to compliant models to assure uninterrupted operation. Non-compliant systems may continue to operate beyond January 1, 2005 on an “unprotected” basis. Unprotected basis means that if any of these transmitters cause harmful interference to compliant transmitters, the owner will be required to shut down the transmitters immediately.

#### 4.4 Existing Licenses

NWS is ending a long-standing practice of applying for new NTIA licenses on behalf of AFWS owners, and plans to delete existing assignments for stations that it neither owns nor operates. The reasons for these changes are:

- AFWS operators who file with the FCC make use of a modern, web-based licensing system that enables applicants to efficiently file online requests, obtain automatic renewal notifications, and check status of pending applications. The NWS/NTIA filing system has no such features.
- The NTIA assesses Federal agencies annual database administration costs of one hundred dollars for each license record, which may be passed on to NWS. By contrast, the FCC imposes no licensing fees for state/local governments and non-profit agencies.
- The AFWS owner is, by law, the appropriate licensee. As the purchaser, operator and maintainer of transmitters bought on their own behalf, AFWS operators have the responsibility to comply with rules that govern transmitter use.
- NWS has no ongoing resources to provide support for AFWS transmitter compliance.

NWS recognizes the importance of AFWS data, and will work closely with AFWS owners to manage an orderly transition. NWS HSD has established a contract that will assist AFWS owners with renewals. NWS personnel should refer cooperators to [Hydro.Radio.Freq@noaa.gov](mailto:Hydro.Radio.Freq@noaa.gov) for assistance with licensing questions. During this process, some AFWS owner-operators may choose not to apply for FCC licenses, or may lack resources to upgrade transmitters to meet NTIA narrowband regulations. In extreme cases it is possible that the local WFO/RFC could experience the permanent loss of AFWS data. In other cases it is possible that unauthorized transmissions will occur if the AFWS owner-operator fails to follow through with obtaining FCC licenses. Section 4.8 describes special procedures that NWS personnel should follow to reduce these possibilities and assure that an orderly licensing transition occurs.

In a few isolated cases NWS has assumed ownership and operational responsibility for transmitters that link the AFWS to local WFO/RFC. In cases where NWS is clearly the owner/operator of the transmitter, NWS will obtain NTIA approval through each Region’s Regional Frequency Manager. NWS policy discourages the long term continuation of such arrangements. Staff members should work with AFWS system owner/operators to transfer ownership and licensing responsibility to the AFWS system owner to the extent it is feasible. Licensing arrangements should be renegotiated and included in Memoranda of Agreement between NWS and the AFWS owner/operator.

#### 4.5 Applying for an FCC License

AFWS owner-operators who wish to use radio transmitters on Federal hydrologic frequencies are required to follow a three step process before legally being allowed to transmit:

- Obtain a letter supporting the use of Federal hydrologic frequencies from the NWS.
- Obtain approval to use Federal hydrologic frequencies (see Section 4.1 above).
- Obtain an FCC license authorizing transmitter use. File online, and attach (1) and (2) as part of the application.

To complete Step 1, the AFWS owner-operator has to send a request to the NWS that declares an intent to:

- Own and operate a hydrologic data collection network at no cost to NWS
- Provide data at no cost to NWS
- Permit free distribution of collected data by NWS

Upon receipt of the request, the NWS will provide a letter of endorsement, indicating support for the request, with a copy of the original letter attached. The NWS letter of endorsement should identify the name of the applicant's organization, the benefit the AFWS will have to local NWS operations, and knowledge of the applicant that supports the applicant's likely ability to sustain an operational AFWS for the long term.

Step 2 requires the AFWS owner-operator to provide information for Federal hydrologic radio frequency approval. NOAA chairs a panel of Federal agencies that review the request to affirm that the request is a legitimate hydrologic use, and the hydrologic information is not already available from other activities. Information required includes:

- Letter of request and endorsement described in Step 1 above
- Location name
- Type of station transmitter (sensing, repeater, base station, etc.)
- Latitude and longitude of station to the nearest second
- Transmit (T) and receive (R) frequencies required
- Transmitter Output Power in watts
- Antenna type (yagi, corner reflector, or collinear)
- Antenna orientation (non-directional, or three digit number in degrees from true north if directional)
- Antenna gain in decibels (dBd)
- Antenna height above ground (feet)
- Station ground elevation above mean sea level
- Necessary bandwidth of emission expressed in kilohertz using the letter K in lieu of the decimal (e.g., use 2K85 instead of 2.85 KHz)
- Emission Classification Symbols (use "F1D")
- Type of hydrologic data to be transmitted (precipitation, river stage, etc.)
- Map showing location of transmitting and receiving stations and limits of operational area. A coordinate grid (latitude and longitude) should be shown on the map. When proposed stations are additions to or modifications of an existing network, the map should show the complete system that will exist after pending actions are completed.
- Justification that explains how the collected data will be used and why a radio is to be used in lieu of land lines or other means.

Because much of the information required for Federal hydrologic radio frequency approval is the same as the FCC filing information, AFWS owner-operators can reduce workload by using the FCC's online Universal Licensing System (ULS) to generate information for both purposes. Details are described in Appendix B. The email address for the Federal hydrologic radio frequency approval is: [Hydro.Radio.Freq@noaa.gov](mailto:Hydro.Radio.Freq@noaa.gov). Mailing address is:

Federal Hydrologic Radio Frequency Panel  
National Weather Service, SSMC2 13466  
Office of Climate, Water and Weather Services  
1325 East-West Highway  
Silver Spring, MD 20910-3283

Note that the hydrologic frequency coordination typically takes at least a month, but the FCC's ULS system purges all incomplete applications after 30 days. To avoid losing the data that had been entered in the ULS while waiting for hydrology approval, the AFWS operator should use the "Check Errors" button in the ULS to re-start the 30-day clock.

If the AFWS operator's proposal is rejected for Federal hydrologic radio frequency use, a counter-proposal will be suggested. If the AFWS operator accepts the counter-proposal, the Federal panel will advise the AFWS operator of required revisions to the original proposal in order to overcome the objections. All transmitter modifications, including changes to station locations, require new Federal hydrologic radio frequency approval and FCC license modifications.

#### **4.6 License Renewal**

FCC Licenses are normally valid for a period of ten years. The non-Federal agency that holds the license is responsible for renewing the license before the expiration date, using the ULS. When renewing, the applicant may use the original letter of support, but is required to obtain a new approval letter (paragraph 4.5, step 2) for Federal hydrologic radio frequency use before filing with the FCC.

#### **4.7 Responsibility of Licensee**

The licensee is responsible for all radio transmissions that occur. If the transmissions cause interference with another project, the license holder will be ordered by the authorizing agency (either NTIA or FCC) to correct the situation. Corrective action will be taken or penalties may be imposed. When the authorized frequency assignment(s) is no longer needed, termination of the operation should be reported through appropriate channels to the FCC or NTIA, and to [Hydro.Radio.Freq@noaa.gov](mailto:Hydro.Radio.Freq@noaa.gov).

#### **4.8 Special Procedures for Transitioning Licenses from NWS to non-NWS Entities**

NWS staff should follow these procedures to assist the transition of AFWS operators to FCC licensing. This process will give owners notice that the license has to be applied for, how to apply, and what assistance might be available. It also tracks the licensing progress by the AFWS owner, and gives NWS the ability to delete its own licenses as corresponding new licenses from AFWS owners are approved by the FCC. The process does not assign a specific date for closure, but will implement a tracking method to assure all station owners are contacted prior to each

station's next NTIA five year review (renewal). It is important that every effort is made to communicate and work with the AFWS owners, because failure to follow these procedures could eventually result in deleted licenses and cause unintended illegal operation.

1. Identify AFWS systems with NWS licenses. Each region's Regional Frequency Manager should provide a current list of NWS-licensed transmitters to the Hydrologic Service Division chiefs. These lists should, in turn, be distributed to appropriate WFO/RFC personnel for initial contact.
2. Talk to the system owners. Explain why the NWS is asking AFWS owners to obtain FCC licenses, as described in Section 4.4.
3. Send a formal request. Using the sample provided in Appendix B, send a letter or email to the AFWS owner. Also, send a copy to [Hydro.Radio.Freq@noaa.gov](mailto:Hydro.Radio.Freq@noaa.gov) so that the contact information is recorded. The sample letter provides sources of information and assistance for AFWS owners.
4. If the AFWS operator responds affirmatively, the applicant will apply for Federal hydrologic frequency approval through a submission to [Hydro.Radio.Freq@noaa.gov](mailto:Hydro.Radio.Freq@noaa.gov). The [Hydro.Radio.Freq@noaa.gov](mailto:Hydro.Radio.Freq@noaa.gov) contact point will assure that the NWS license is deleted at the same time the FCC license is approved. If the [Hydro.Radio.Freq@noaa.gov](mailto:Hydro.Radio.Freq@noaa.gov) contact point sees that no response has been received after 60 days, the contact point will notify the regional representative who initiated the action for follow up.
5. If the AFWS operator responds that the transmitters are no longer operational, the tracking monitor will initiate an instruction to delete the NWS license.
6. If no contact with the AFWS operator is initiated, the [Hydro.Radio.Freq@noaa.gov](mailto:Hydro.Radio.Freq@noaa.gov) will contact the Regional Frequency Manager to establish status.

## Chapter 5 Memorandum of Agreement

### 5.1 Uses for an Agreement

An agreement, also termed a Memorandum of Agreement, Interagency Agreement or Memorandum of Understanding, is used to specify the terms under which the NWS engages in collaborative undertakings in which the parties have a mutual interest. NWS recommends the use of written agreements to clearly establish each party's AFWS responsibilities. Such agreements are "good-faith" efforts to adhere to mutually beneficial conditions. Aside from obvious areas of agreement, the MOA should also include language that tries to anticipate and address worst-case situations, such as when one party fails to fulfill its obligations, or wishes to withdraw or amend terms. The MOA should be periodically reviewed to assure that it is current. In most cases, a well run AFWS with active participants will seldom refer to the MOA. Experience shows, however, that the MOA becomes very important as time passes. Participating agencies' policies and personnel will inevitably change. As changes occur, the agency's "institutional memory" that provided support to the AFWS will also change--sometimes to the detriment of the AFWS and its other partners. The MOA serves as a reminder to all participants of the institutional obligations made by their predecessors, and the periodic reviews of the MOA enable all parties to continually reassess their commitments and communicate them to others.

The NOAA Office of General Counsel has determined that AFWS agreements are most appropriately classified as Joint Project Agreements, as defined in 31 USC Section 1525. The stipulations of a Joint Project Agreement are:

- Any non-profit, research or any public organization, including other federal organizations may participate
- Projects focus on matters of mutual interest to all participating parties
- Projects could not be done as effectively without the participation of all parties
- Project is essential to the Department of Commerce and NOAA missions

### 5.2 Critical Agreement Requirements

All agreements will include the following elements, terms and conditions, as appropriate:

- Project Title
- Citation of Agreement, Program, and Legal Authority (See example in Appendix A)
- Identify of All Parties
- Purpose and Scope.
- Responsibilities of Each Party
- Data Access – The NWS desires to have full and unrestricted access to the data. Please see NDS1-1201 Obtaining Environmental Data from External Parties (<http://www.nws.noaa.gov/directives/sym/pd00112001curr.pdf>) for further details regarding terms and conditions that may apply if full an unrestricted access to the data cannot be granted.
- Period of Performance
- Resource Requirements
- Non-monetary Resources (if applicable)
- Channels and Protocols for working relationships and liaisons.



- Guidelines for Release of Technical and Public Information regarding the project, including rights for data access and use.
- Method for Dispute Settlement
- Termination/Cancellation Clause
- Performance Standards and Review Procedures
- Approving Signatures and Clearances

These points have been encapsulated in a generic Memorandum of Agreement (Appendix A) that is recommended for use by NWS offices working with AFWS owner-operators. More information about MOAs may be found at the NOAA Chief Financial Officer's website at ([http://www.nws.noaa.gov/cfo/budget\\_execution\\_accountability/agreeover.htm](http://www.nws.noaa.gov/cfo/budget_execution_accountability/agreeover.htm))

### **5.3 Signatories**

There is no hard fast rule for AFWS signatories. The decision of who may be a signatory is left to the Region, and may be delegated to the local WFO or RFC. Likewise, the cooperator's AFWS signatory may be anyone with sufficient authority to act on behalf of his/her agency in matters of this type. Such authority is likely to vary widely among cooperators. Because the operation of an AFWS is likely to require a commitment of local resources, it may be beneficial (though not required) to obtain an MOA signed by a mayor, county commissioner, or other local official with authority to appropriate resources for the AFWS.

## Appendix A General Memorandum of Agreement

This Memorandum of Agreement (MOA) between the National Weather Service (NWS) of the National Oceanic and Atmospheric Administration (/NOAA), an agency of the U.S. Department of the Commerce, and \_\_\_\_\_, herein referred to as the Cooperator, is undertaken for the development and operation of an Automated Flood Warning System (AFWS).

The Parties, providing their best assurances, represent that they have a mutual interest in identifying and formalizing the basic flood control, forecasting and warning support services to be provided under this Agreement. The costs associated with this project have been equitably apportioned with each party bearing the costs associated with its participation. This agreement does not involve the transfer of funds between parties. All costs incurred by the parties under this agreement are subject to the availability of appropriated funds.

### 1) Legal Authority

NWS authority to conduct its meteorological and flood forecasting operations and activities is derived from 15 U.S.C. § 313 et seq., which provides that the NWS, under the direction of the Secretary of Commerce, shall have charge of the forecasting of weather, the issue of storm warnings, the display of weather and flood signals for the benefit of agriculture, commerce, and navigation...the distribution of meteorological observations as may be necessary to establish and record the climatic conditions of the United States, or as are essential for the proper execution of the foregoing duties; 15 U.S.C. § 1525, the Department of Commerce's Joint Project authority; and 33 U.S.C. § 706, flood control authority.

### 2) Purpose of Agreement

The purpose of this agreement is to establish and outline the respective responsibilities of each Party in developing and implementing a program for the installation and operation of an AFWS in the area designated in Attachment I, for the purpose of providing advance warning of (flash) flooding.

This project is necessary and essential to further the mission of the NWS in that it will provide data related to the hydrologic activity in the designated area, which is needed to produce a specific forecast for residents.

The NWS has determined that this project cannot be done as effectively without the participation of the Cooperator, because the Cooperator is the owner and operator of the equipment used to monitor the designated area, and is the provider of the data to the NWS, without which the NWS would not be able to monitor the hydrologic activity.

### 3) Responsibilities of the Cooperator

Ensure development and operation of an emergency response plan prior to or concurrent with the execution of this MOA that includes coordination with the NWS and dissemination of warnings to the public;

- a) Install, maintain, and operate the flood warning system, including hardware, software, and communications at locations specified in Attachment. This responsibility shall include maintenance and funding of the NWS base station, if any, located upon Federal government premises, to deliver information in near real-time;
- b) Provide calibration of the AFWS software hydrologic model on an ongoing basis.
- c) Arrange for volunteer network observers that can provide rainfall and/or flood information and act as backup should automated equipment fail;
- d) Provide training in a timely manner to the NWS on the operation of the AFWS, including changes and/or upgrades to the system;
- e) Designate, by name or position a local representative who shall act as the Cooperator's Flood Warning Coordinator, designating also at least one back-up representative;
- f) Establish an emergency operations center for the purpose of:
  - Receiving and recording all reports and flood conditions;
  - Promptly relaying or making available all such reports to the Cooperator's Flood Warning Coordinator or designee;
  - Serving as the distribution point for all warnings and statements.

When emergency conditions and lack of time prevent warnings being issued by the NWS, the designated local official(s) shall be prepared to issue appropriate warnings, ensuring that, in addition to general public distribution, flood warnings or statements reach warning action points as listed in the Cooperator's response plan, and relaying stream and rainfall reports, flood data, and warnings to the local NWS office as soon as possible after local requirements have been satisfied.

- g) Monitor the AFWS and immediately notify the NWS of any significant problems;
- h) Review annually with the NWS this MOA and the response plan, updating as necessary;
- i) Conduct an annual drill, in coordination with the NWS, to test the system.
- j) Authorize the NWS to disclose or redistribute data provided by the gage in whole or in part in an unrestricted manner.

#### **4) Responsibilities of the NWS**

- a) Designate a primary NWS contact point (focal point), and at least one back-up contact point at the local NWS forecast office, for routine coordination; concerning AFWS training, maintenance, operations, and related issues. If the primary/backup focal points are unavailable during flooding, the MIC or his/her designee will act as the AFWS owner/operator point of contact.
- b) Provide knowledge about AFWS design and equipment;
- c) Provide information on hydrologic history and current hydrometeorological status of the service area;
- d) Advise on site specific gage locations;
- e) Provide specific information about NWS communications interfaces that will allow the AFWS user to successfully provide data to AWIPS;
- f) Provide contact names, addresses, and procedures for AFWS owner-operators to obtain Federal hydrological radio frequency approval;
- g) Provide information on flood forecasts and warnings;
- h) Assist the AFWS cooperator in determining ways to obtain NWS products;

- i) Develop local forecasting procedures in conjunction with the appropriate NWS River Forecast Center;
- j) Distribute warning information;
- k) Disclose or redistribute data provided by the gage in whole or in part in an open and unrestricted manner.
- l) Provide training for the AFWS cooperator's flash flood coordinators and local authorities, including network observers. The scope of training includes:
  - The NWS flood/flash flood warning program
  - Local flood warning programs
  - Need for emergency response planning
  - How to establish and maintain observer networks

### **5) Title to Equipment**

Title to any equipment purchased under this Agreement shall remain vested with the purchaser of that equipment.

### **6) Resource Requirement**

No transfer of financial resources will occur under this Agreement. In the event that either party to this Agreement anticipates funding limitations that would result in the failure to meet all or any portion of their responsibilities, the responsible party will promptly notify the appropriate contact person for this Agreement. Pursuant to each Party's in-kind contributions, all costs incurred by the Parties under this Agreement shall be equitably apportioned among the Parties, with each Party bearing its own costs of performance under this Agreement..

Due to the nature of this agreement and the mutual benefit provided to both Parties, completion of each Party's responsibilities under this Agreement is subject to the availability of appropriated funds. Each Party will be responsible for obtaining its own funding for the activities agreed upon by the Parties. If adequate appropriations are not forthcoming, the Parties may terminate this Agreement upon mutual written consent.

### **7) Duration of Agreement, Termination, and Amendments**

- a) Duration: This Agreement is rendered effective on the date of the last signature shown below upon execution by the Parties hereto. This Agreement shall be reviewed as changes occur, and updated if necessary. The Agreement shall remain in force until completion of the tasks identified herein, but will not be effective for a period in excess of five (5) years from the effective date. This agreement is subject to the availability of appropriated funds.
- b) Termination: Any Party may terminate this agreement by providing 60 days written notice to the other party. All equipment shall be returned within 60 days to the purchasing Party of such equipment. Equipment shall be returned in the condition it was as the time of termination.
- c) Amendments: The Agreement may be amended at any time by mutual consent of the Parties. Additional responsibilities by either Party are listed on an Addendum attached

hereto and made a part hereof. Changes and/or modifications to this agreement shall be in writing.

In Witness Whereof, the Parties have duly acknowledged the aforementioned representations and executed this agreement.

AGREED TO AND BY:

Cooperator

BY: \_\_\_\_\_  
NAME: \_\_\_\_\_  
TITLE: \_\_\_\_\_  
ADDRESS: \_\_\_\_\_  
ADDRESS: \_\_\_\_\_  
DATE: \_\_\_\_\_

NWS

BY: \_\_\_\_\_  
NAME: \_\_\_\_\_  
TITLE: \_\_\_\_\_  
ADDRESS: \_\_\_\_\_  
ADDRESS: \_\_\_\_\_  
DATE: \_\_\_\_\_

**Attachment I to Memorandum of Agreement**

1. Area/Specific Locations Covered:
  
  
  
  
  
  
  
  
  
  
2. Cooperator Focal Point, including Address, Telephone, and E-Mail:
  
  
  
  
  
  
  
  
  
  
3. Cooperator Alternate Focal Point:
  
  
  
  
  
  
  
  
  
  
4. NWS Focal Point:
  
  
  
  
  
  
  
  
  
  
5. Equipment Owned/Operated and Maintained by Cooperator:

**Appendix B Guide for Obtaining an FCC License on Hydrologic Radio Frequencies**

**1. Introduction**

**1.1 Overview**

The purpose of this guide is to assist Automated Flood Warning System (AFWS) owners on how to obtain Federal Communications Commission (FCC) licenses for Federal hydrologic radio frequencies. These instructions should also be used to transition NWS licenses to non-Federal owners in cases where NWS does not operate or maintain the transmitter. The FCC provides a web-based method for applying for transmitter licenses called the Universal Licensing System (ULS). The ULS has many advantages over paper application filing:

**Memory** – The ULS remembers what you have already entered on a form and inserts that data into subsequent forms. It also monitors what you type, and provides prompts if you try to enter inaccurate information to ensure you fill out a complete and correct application.

**Accessibility** – The ULS uses common Internet browser software for ease-of-use, and can be accessed from any location with Internet capability. Applications filed by the ULS arrive immediately—there are no delay times or lost applications.

**Flexibility** – The system dynamically creates screens that will only ask you for the information that is needed. Likewise, if you want to make an administrative change in the FCC licensing database, check application status, or are required to submit a filing on a specific call sign, you'll be able to access your records with a password and immediately make the changes.

The ULS is accessible via the web at <http://wireless.fcc.gov/uls/> and works with most popular web browsers. Using the ULS requires a basic knowledge of computers, knowledge of how to use and configure web browsers such as Microsoft Internet Explorer and Netscape Navigator, and software that scan documents into Adobe Portable Document Format (PDF). Many vendors sell software that can convert scanned documents into PDF. They can be found by entering the keywords “PDF conversion” using any popular Internet search engine (Yahoo, Google, MSN, etc.). A free PDF reader may be downloaded at <http://www.adobe.com>

**1.2 Frequencies Available For Use**

The following Federal government frequencies (in MHz) are available for use through the ULS: Use of these frequencies is restricted to hydrologic data collection. All users are required to obtain Federal hydrologic approval before applying for an FCC license to use these frequencies. Section 2.5 explains how this is accomplished.

All Frequencies shown in MHz

169.4250	170.2250	171.0250	171.8250	406.125	412.6625	415.1250
169.4375	170.2375	171.0375	171.8375	406.175	412.6750	415.1750
169.4500	170.2500	171.0500	171.8500		412.6750	
169.4625	170.2625	171.0625	171.8625		412.6875	
169.4750	170.2750	171.0750	171.8750		412.7125	
169.4875	170.2875	171.0875	171.8875		412.7250	
169.5000	170.3000	171.1000	171.9000		412.7375	

169.5125	170.3125	171.1125	171.9125	412.7625
169.5250	170.3250	171.1250	171.9250	412.7750

NOTE: Applications for northern United States counties may require Canadian government coordination. Consult with the FCC for further information.

### 1.3 Configuring Web Browsers

The FCC's ULS requires:

- Either a Netscape 4.7.x, or Internet Explorer 5.5+ browser. Other browsers may work, but have not been tested by the FCC
- Java and JavaScript must be enabled.
- "Accept All Cookies" must be enabled.

More information on how to configure browsers is available at <http://esupport.fcc.gov/gettingconnected.htm>. Applicants should also review the FCC's online filing assistance at <http://esupport.fcc.gov/licensing.htm>.

## 2. Licensing Process

### 2.1 New Applicants

Before using the ULS system the first time, applicants have to register with the ULS to obtain:

- FCC Registration Number (FRN)
- Password

Applicants are required to provide the Employer Identification Number (EIN) and agency contact information, to use the ULS. The Internal Revenue Service issues EIN's.

### 2.2 Requesting New Licenses

The following pages provide step-by-step instructions on how to enter technical information into the ULS. The steps are:

- Phase I – Collect Information
- Phase II-- Enter information to the ULS, and save it as a draft application
- Phase III—Use the draft application to generate a request for Federal hydrologic radio frequency approval
- Phase IV—Attach the Federal hydrologic radio frequency approval to the ULS draft, and file it as a completed FCC application.

**IMPORTANT:** The FCC's ULS online data entry process allows applicants to save incomplete applications as drafts before submitting them for acceptance. Because of time delays in obtaining attachments required for FCC filing, applicants may need to create draft applications before final submissions are sent to the FCC. The ULS, however, will automatically delete all draft applications after 30 days of inactivity. To avoid losing draft applications, applicants have to re-access draft applications at least once every 30 days by using the "Check Errors" button to re-start the 30 day clock.



### 2.3 Phase I - Collect All Pertinent Information For Each License Required

The following information has to be collected for each hydrologic frequency license:

- Applicant — agency name, name of contact person, address, phone, email.
- Control Point — address, city/town, state, county, phone number for each administrative office that controls or administers the station.
- Administrative -- each existing call sign that is part of this network.
- Location — latitude, longitude, street address or location description, city/town, state, antenna support structure type, ground elevation, height of support structure, height from ground to tip of antenna.
- Antenna — azimuth in degrees (would be 360 if omni type), beamwidth (would be 360 if omni type), polarization (e.g., vertical, horizontal, etc.), gain in dB.
- Frequency — transmit frequency, operational output power (watts), ERP.

### 2.4 Phase II - Enter All Information Collected From Phase I Into The ULS

Enter all of the information collected in Phase I into the ULS, then select "Online Filing." After the ULS application finishes loading, enter the information in the following order:

2.4.1 Application Information Tab

Figure B-1 shows the Application Information tab. The shaded boxes are auto-filled. The editable fields (non-shaded) should have the following information filled-in.

NOTE: The editable information should be filled-in as shown in the sample application below:

Administrative	Location	Antenna	Frequency
Application Information	Applicant	Ownership Questions/Qualification Questions	General Certification Statements
<p><b>FCC 601</b>      <b>FCC Application for Wireless Telecommunications Bureau</b>      Approved by OMB</p> <p style="text-align: center;"><b>Radio Service Authorization</b>      3060-0798</p>			
<p><b>Application Purpose</b> <input type="text" value="NE"/>      Radio Service Code: <input type="text" value="PW"/>      File Number: <input type="text"/>      Callsign: <input type="text"/></p>	<p>If this request is for a Developmental License, Demonstration License, or a Special Temporary Authorization (STA), enter the code and attach the required exhibit as described in the instructions. Otherwise enter N (Not Applicable) <input type="text" value="N"/></p> <p>If this request is for Special Temporary Authority due to an emergency situation, enter 'Y'; otherwise enter 'N'. Refer to Rule 1.915 for an explanation of situations considered to be an emergency.      <input type="radio"/> Yes      <input type="radio"/> No</p> <p>If this request is for a New, Amendment, Renewal Only, or Renewal/Modification enter the requested authorization expiration date, MM/DD (this item is optional): <input type="text"/></p> <p>Is this request "major" as defined in Section 1.929 of the Commission's Rules when read in conjunction with the applicable radio service rules found in Parts 22 and 90 of the Commission's Rules? (NOTE: This question only applies to certain site-specific applications. See the instructions for applicability and full text of Section 1.929).      <input type="radio"/> Yes      <input checked="" type="radio"/> No</p> <p>Does this filing request a Waiver of the Commission's rules? If 'Yes', attach an exhibit providing rule numbers and explaining circumstances.      If a feeable waiver request is attached, multiply the number of stations (call signs) times the number of rule sections and enter the result.      Are the frequencies or parameters requested in this filing covered by grandfathered privileges, previously approved by waiver, or functionally integrated with an existing station?      <input type="radio"/> Yes      <input checked="" type="radio"/> No</p> <p><input type="radio"/> Yes      <input checked="" type="radio"/> No      <input type="text"/>      <input type="radio"/> Yes      <input checked="" type="radio"/> No</p> <p>Are attachments being filed with this application?      <input checked="" type="radio"/> Yes      <input type="radio"/> No</p>		
<p><b>Regulatory Status</b></p> <p>This filing is for authorization to provide or use the following type(s) of radio service offering (enter all that apply):</p> <p><input type="checkbox"/> Common Carrier      <input type="checkbox"/> Non-Common Carrier      <input checked="" type="checkbox"/> Private, internal communications      <input type="checkbox"/> Broadcast Services      <input type="checkbox"/> Band Manager</p>			
<p><b>Type of Radio Service</b></p> <p>This filing is for authorization to provide the following type(s) of radio service (enter all that apply):</p> <p><input checked="" type="checkbox"/> Fixed      <input type="checkbox"/> Mobile      <input type="checkbox"/> Radiolocation      <input type="checkbox"/> Satellite (sound)      <input type="checkbox"/> Broadcast Services</p> <p>Interconnected Service?      <input type="radio"/> Yes      <input checked="" type="radio"/> No</p>			
<p><b>Fee Status</b></p> <p>Is the Applicant exempt from FCC application fees?      <input checked="" type="radio"/> Yes      <input type="radio"/> No</p> <p>Is the Applicant exempt from FCC regulatory fees?      <input checked="" type="radio"/> Yes      <input type="radio"/> No</p> <p>Receipt Date (MM/DD/YY)</p>			

Figure B-1. Sample Application Information Tab

2.4.2 Applicant Tab

Figure B-2 shows the Applicant tabbed-panel based on sample data. It should be customized based on the applicant’s own information.

Administrative	Location	Antenna	Frequency
Application Information	Applicant	Ownership Questions/Qualification Questions	General Certification Statements
Control Point			

**Applicant Information**

FCC Registration Number (FRN):  The Licensee is a(n):

First Name:  MI:  Last Name:  Suffix:

Entity Name:

Attention To:

P.O. Box:  Address:

City:  State:  Zip:

Phone No.:  FAX:  E-Mail:

Name of Real Party in Interest (if different from applicant):  TIN of Real Party in Interest:  Enter to retrieve RPI name

**Name of Contact Representative** (if different from the applicant)

First Name:  MI:  Last Name:  Suffix:

Company:

P.O. Box:  Address:

City:  State:  Zip:

Phone No.:  FAX:  E-Mail:

**Race, Ethnicity, Gender of Applicant/Licensee (Optional)**

Race:  American Indian or Alaska Native  Asian  Black or African-American  
 Native Hawaiian or Other Pacific Islander  White

Ethnicity:  Gender:

?	Login	Print Preview	Attachment	Check Errors	Previous Page	Next Page	Ownership
---	-------	---------------	------------	--------------	---------------	-----------	-----------

Figure B-2. Sample Applicant Tab

2.4.3 Ownership/Qualification Questions Tab

Answers to the questions displayed in Figure B-3 are required and should be self-explanatory.

Administrative	Location	Antenna	Frequency
Application Information	Applicant	Ownership Questions/Qualification Questions	General Certification Statements   Control Point
<b>Alien Ownership Questions (If any answer is Yes, attach exhibit explaining circumstances.)</b>			
Is the applicant a foreign government or the representative of any foreign government?			No
Is the applicant an alien or the representative of an alien?			No
Is the applicant a corporation organized under the laws of any foreign government?			No
Is the applicant a corporation of which more than one-fifth of the capital stock is owned of record or voted by aliens or their representatives or by a foreign government or representative thereof or by any corporation organized under the laws of a foreign country?			No
Is the applicant directly or indirectly controlled by any other corporation of which more than one-fourth of the capital stock is owned of record or voted by aliens, their representatives, or by a foreign government or representative thereof, or by any corporation organized under the laws of a foreign country?			No
<b>Basic Qualification Questions (If any answer is Yes, attach exhibit explaining circumstances.)</b>			
Has the applicant or any party to this application or amendment had any FCC station authorization, license, or construction permit revoked or had any application for an initial, modification or renewal of FCC station authorization, license, construction permit denied by the Commission?			No
Has the applicant or any party to this application or amendment, or any party directly or indirectly controlling the applicant, or any party to this application ever been convicted of a felony by any state or federal court?			No
Has any court finally adjudged the applicant or any party directly or indirectly controlling the applicant guilty of unlawfully monopolizing or attempting unlawfully to monopolize radio communication, directly or indirectly, through control of manufacture or sale of radio apparatus, exclusive traffic arrangement, or any other means or unfair methods of competition?			No
Is the applicant or any party directly or indirectly controlling the applicant, currently a party in any pending matter referred to in the preceding two items?			No

Figure B-3. Sample "Ownership Questions/Qualification Questions" Tab

2.4.4 General Certification Statements Tab

The contact person who is responsible for the contents of the application has to type in his/her name and title, as shown in Figure B-4. The signature field will automatically be filled in with this person's name.

Administrative	Location	Antenna	Frequency
Application Information	Applicant	Ownership Questions/Qualification Questions	General Certification Statements
			Control Point

**General Certification Statements**

The applicant waives any claim to the use of any particular frequency or of the electromagnetic spectrum as against the regulatory power of the United States because of the previous use of the same, whether by license or otherwise, and requests an authorization in accordance with this application.

The applicant certifies that grant of this application would not cause the applicant to be in violation of any pertinent cross-ownership, attribution, or spectrum cap rule.\*

\*If the applicant has sought a waiver of any such rule in connection with this application, it may make this certification subject to the outcome of the waiver request.

The applicant certifies that all statements made in this application and in the exhibits, attachments, or documents incorporated by reference are material, are part of this application, and are true, complete, correct, and made in good faith.

The applicant certifies that neither the applicant nor any other party to the application is subject to a denial of Federal benefits pursuant to Section 5301 of the Anti-Drug Abuse Act of 1988, 21 U.S.C § 862, because of a conviction for possession or distribution of a controlled substance. This certification does not apply to applications filed in services exempted under Section 1.2002(c) of the rules, 47 CFR § 1.2002(c). See Section 1.2002(b) of the rules, 47 CFR § 1.2002(b) for the definition of 'party to the application' as used in this certification.

The applicant certifies that it either (1) has a current Form 602 on file with the Commission, (2) is filing an updated Form 602 simultaneously with this application, or (3) is not required to file Form 602 under the Commission's rules.

The applicant certifies that the facilities, operations, and transmitters for which this authorization is hereby requested are either: (1) categorically excluded from routine environmental evaluation for RF exposure as set forth in 47 C.F.R. § 1.1307(b); or, (2) have been found not to cause human exposure to levels of radiofrequency radiation in excess of the limits specified in 47 C.F.R. § 1.1310 and 2.1093; or, (3) are the subject of one or more Environmental Assessments filed with the Commission.

**Typed or Printed Name of Party Authorized to Sign:**

First Name:  MI:  Last Name:  Suffix:

Title:

Signature:

**Upon grant of this license application, the licensee may be subject to certain construction or coverage requirements. Failure to meet the construction or coverage requirements will result in termination of the license. Consult appropriate FCC regulations to determine the construction or coverage requirements that apply to the type of license requested in this application.**

**WILLFUL FALSE STATEMENTS MADE ON THIS FORM OR ANY ATTACHMENTS ARE PUNISHABLE BY FINE AND/OR IMPRISONMENT (U.S. Code, Title 18, Section 1001) AND/OR REVOCATION OF ANY STATION LICENSE OR CONSTRUCTION PERMIT (U.S. Code, Title 47, Section 312(a)(1)), AND/OR FORFEITURE (U.S. Code, Title 47, Section 503).**

?	Login	Print Preview	Attachment	Check Errors	Previous Page	Next Page	Ownership
---	-------	---------------	------------	--------------	---------------	-----------	-----------

Figure B-4. Sample "General Certification Statements" Tab

2.4.5 Control Point Tab

A Control Point may be defined as the administrative office that is responsible for maintenance of the transmitters and/or the receiver point. Figure B-5 shows an application after one Control Point has been added.

- At least one control point has to be listed.
- Multiple Control Points can be listed on a license.
- The maximum number of locations that can be associated to a single control point is 20.

Click on the "Add" button and then complete the location/phone information for the Control Point used by all of the stations listed on the license.

Administrative	Location	Antenna	Frequency
Application Information	Applicant	Ownership Questions/Qualification Questions	General Certification Statements
Control Point			

Select Control Point

1 542 CountyFarm	Action: <input type="button" value="A"/>
------------------	--

<input type="button" value="Add"/> <input type="button" value="Modify"/> <input type="button" value="Delete"/> <input type="button" value="Save"/> <input type="button" value="Clear"/>	<p>Address: <input type="text" value="1234 Courthouse Lane"/></p> <p>City or Town: <input type="text" value="Anytown"/> State: <input type="text" value="PA"/></p> <p>County: <input type="text" value="Sullivan"/></p> <p>Phone Number: <input type="text" value="(717)555-3456"/></p>
---	---

Figure B-5. Sample "Control Point" Tab

2.4.6 Administrative Tab

In the Rule Section text box under the administrative tab, enter “90.173c” as shown in Figure B-6. The "Describe Activity" text box should be completed with a statement such as “Collect hydrologic data in cooperation with Federal government. See attached letter of approval”. Section 2.5 provides more information about this attachment. The Frequency Coordinator Section is not editable, nor does it apply.

Applicants should click on the "Add Call Sign" button and list any associated FCC call signs that are also part of this local network. It is necessary to use the "Save Call Sign" button before adding a second call sign.

Application Information	Applicant	Ownership Questions/Qualification Questions	General Certification Statements	Control Point
Administrative	Location	Antenna	Frequency	

**Eligibility**

Rule Section:  Describe Activity:

**Frequency Coordinator Information (if not self-coordinated)**

Freq Coordination #:

Name of Freq Coordinator:

Other:

Telephone Number:  Coordination Date:  Has this application been successfully coordinated?:

**Extended Implementation (Slow Growth)**

Are you requesting a new or modified extended implementation plan?   
 If "Yes", attach an exhibit with a justification and a proposed station construction schedule.

**Associated Call Signs**

Select Call Sign #	Action	Call Sign
WPHF929	<input type="button" value="Add Call Sign"/>	WPHF929
WPHF933	<input type="button" value="Modify Call Sign"/>	
WPHF937	<input type="button" value="Delete Call Sign"/>	

**Broadcast Auxiliary Only**

Is there an associated Parent Station?

Facility Id of Parent Station:  Radio Service of Parent Station:  City of Parent Station Principal Community:  State of Parent Station Principal Community:

If there is no associated parent station, this application is a:  State of Primary Operation:

?	Login	Print Preview	Attachment	Check Errors	Previous Page	Next Page	Ownership
---	-------	---------------	------------	--------------	---------------	-----------	-----------

Figure B-6. Sample "Administrative" Tab

2.4.7 [Location](#) Tab

Referring to Figure B-7, the FCC form allows applicants to enter up to 6 unique transmitter locations per application. A separate application has to be filed for every 6 additional locations.

- Click the "Add" button.
- Complete the editable information for a location.
- Choose "F Fixed" for the location.
- Select "N/A" for "FCC Antenna Structure Registration #" unless the FCC's TOWAIR Determination has stated that antenna structure registration is necessary (see glossary). Completion of Airport Identifier and Site Status boxes is not needed unless the transmitter is near an airport.

If the proposed site is within the National Radio Quiet Zone in VA or WV (see glossary), the date authorization was obtained has to be entered.

Administrative	Location	Antenna	Frequency																
Select Location																			
<table border="1"> <tr><td>1</td><td>Fixed</td><td>41-29-29.8N</td><td>76-36-9.3W</td></tr> <tr><td>2</td><td>Fixed</td><td>41-21-25.0N</td><td>76-32-6.0W</td></tr> <tr><td>3</td><td>Fixed</td><td>41-18-51.8N</td><td>76-38-48.5W</td></tr> <tr><td>4</td><td>Fixed</td><td>41-14-12.2N</td><td>76-42-5.4W</td></tr> </table>		1	Fixed	41-29-29.8N	76-36-9.3W	2	Fixed	41-21-25.0N	76-32-6.0W	3	Fixed	41-18-51.8N	76-38-48.5W	4	Fixed	41-14-12.2N	76-42-5.4W	<input type="button" value="Add"/> <input type="button" value="Save"/> <input type="button" value="Modify"/> <input type="button" value="Clear"/> <input type="button" value="Delete"/>	
1	Fixed	41-29-29.8N	76-36-9.3W																
2	Fixed	41-21-25.0N	76-32-6.0W																
3	Fixed	41-18-51.8N	76-38-48.5W																
4	Fixed	41-14-12.2N	76-42-5.4W																
Action	Location Description	Area of Operation Code	Location Name																
A	F Fixed																		
FCC Antenna Structure Registration # or N/A (FAA Notification not Required)		Registration Number Press Enter to retrieve Tower data	Latitude (DD-MM-SS.S) Longitude (DDD-MM-SS.S)																
<input type="text" value="N/A"/>		<input type="text" value=""/>	<input type="text" value="41-29-29.8"/> <input type="text" value="N"/> <input type="text" value="076-36-09.3"/> <input type="text" value="W"/>																
Street Address, Name of Landing Area, or Other Location Description		City	State																
<input type="text" value="NE corner of the SR87 bridge across Loyalsock Creek"/>		<input type="text" value="Hillsgrove"/>	<input type="text" value="PA"/>																
County		Elevation of Site AMSL (meters) ('a' in antenna structure example):	Overall Ht AGL without appurtenances (meters) ('b' in antenna structure example):																
<input type="text" value="Sullivan"/>		<input type="text" value="309.0"/>	<input type="text" value="4.1"/>																
Support Structure Type		Other																	
<input type="text" value="PIPE Any type pipe"/>		<input type="text" value=""/>																	
Location Number: (only for Area of Operation Code 'A')	Temporary Fixed or Mobile Radius (km)	Airport Identifier	Site Status																
<input type="text" value=""/>	<input type="text" value=""/>	<input type="text" value=""/>	<input type="text" value=""/>																
Maximum Latitude (DD-MM-SS.S) Use for rectangle only (Northwest corner) NAD 83 N or S		Maximum Longitude (DDD-MM-SS.S) Use for rectangle only (Northwest corner)																	
<input type="text" value=""/>		<input type="text" value=""/>																	
Do you propose to operate in an area that requires frequency coordination with Canada?																			
<input type="text" value=""/>																			
Description (only for Area of Operation Code 'O')																			
<input type="text" value=""/>																			
Number of Units	Hand Held	Mobile	Temporary Fixed																
<input type="text" value=""/>	<input type="text" value=""/>	<input type="text" value=""/>	<input type="text" value=""/>																
Would a Commission grant of Authorization for this location be an action which may have a significant environmental effect? See Section 1.1307 of 47 CFR. If 'Yes', submit an environmental assessment as required by 47 CFR, Sections 1.1308 and 1.1311																			
<input type="text" value="No"/>																			
If the proposed site is located in one of the quiet zones listed in Item 27 of the Instructions, provide the date (mm/dd/yy) the proper authority was notified																			
<input type="text" value=""/>																			
?	Login	Print Preview	Attachment																
	Check Errors	Previous Page	Next Page																
	Ownership																		

Figure B-7. Sample "Location" Tab



2.4.8 [Antenna](#) Tab

Referring to Figure B-8, click on the first antenna location under the "Select Location" list. (Up to 6 locations may be displayed.) Then, click on the "1" under "Select Antenna". It should now be possible to click "Add" to enter specifications for that antenna. Since this location is not a repeater there should be only one antenna in the list.

“AAT” should be left blank (see glossary). For "Antenna Ht.", enter the height from tip to ground. If the antenna is a yagi, enter the azimuth relative to the receiver; otherwise, for an omni antenna enter "360". Beamwidth will also be "360" if the antenna is omni-directional. The polarization and gain for the transmitter should be specified in the manufacturer's literature. The figure below shows antenna information for a location that uses a yagi antenna.

Application Information	Applicant	Ownership Questions/Qualification Questions	General Certification Statements	Control Point				
Administrative		Location	Antenna	Frequency				
<p>Select Location</p> <table border="1"> <tr> <td>1</td> <td>36-0-0.0N</td> <td>76-33-33.0W</td> </tr> </table>		1	36-0-0.0N	76-33-33.0W	<p>Select Antenna</p> <table border="1"> <tr> <td>1</td> </tr> </table>	1	<p>Add</p> <p>Modify</p> <p>Save</p> <p>Delete</p> <p>Refresh</p> <p>Clear</p>	
1	36-0-0.0N	76-33-33.0W						
1								
<p>Action: <input type="text" value="A"/></p>								
<p>AAT(meters) <input type="text"/></p>								
<p>Antenna Ht. (meters) <input type="text" value="4.3"/></p>								
<p>Azimuth (degrees) <input type="text" value="221.0"/></p>								
<p>Beamwidth (degrees) <input type="text" value="80.0"/></p>								
<p>Polarization <input type="text" value="V"/></p>								
<p>Gain (dB) <input type="text" value="7.0"/></p>								

Figure B-8. Sample "Antenna" Tab

2.4.9 [Frequency Tab](#)

"Frequency" is the final tab of the ULS licensing application (shown in Figure B-9):

- Click on the first location in "Select Location" > Select your antenna > "Add Freq"
- The lower fields on the form should now be editable. Enter the frequency in the "Lower or Center Frequency" field. (Do not use the other frequency tabs.)
- Enter "FX" for Station Class and "1" for Number of Units.
- Enter the operational power and ERP for the transmitter.
- Click the "Save Freq" button before entering emission information
- Select the specific frequency and click "Add Emission" before typing in the emission designator (see glossary). A typical narrowband transmitter emission designator is 11K0F2D, as shown in the example.
- Click "Save Emission". There will be only one emission listed because there should be just one frequency per location.

Figure B-9 shows frequency and emission information that has been added for the third location transmitting with a single antenna.

Figure B-9. Sample "Frequency" Tab

## 2.5 Phase III - Submit Exported ULS Information for Federal Approval

Before an applicant submits the final application to the FCC, he/she is required to first obtain Federal hydrologic radio frequency approval (See Section 4.1). Federal hydrologic approval is a certification from the Federal Government that the proposed application complies with rules governing hydrologic use. This approval is NOT a license to transmit. NOAA is one of many agencies that reviews the request, and acts as a liaison between the Federal agencies and the applicant. To apply for Federal hydrologic radio frequency approval, the applicant has to submit the following information in PDF format (see glossary) to [Hydro.Radio.Freq@noaa.gov](mailto:Hydro.Radio.Freq@noaa.gov)

- A draft ULS application(s) that has been exported to PDF, containing all technical information about your proposed stations.
- A network drawing or block diagram showing the system configuration.
- A letter to the NWS from the applicant asking for use of federal hydrologic frequencies for hydrologic data collection, and affirming data will be provided to NWS at no cost and for free distribution to the public. (Usually the local forecast office is the contact point.)
- A reply letter from the NWS that supports the request.

If email is unavailable, the information may be sent to the Office of Hydrologic Radio Frequency, NOAA, National Weather Service, SSMC2, Room 13415, Silver Spring, MD 20910.

## 2.6 Phase IV - Complete and File The ULS Application

Phase IV describes how the applicant uploads the Federal hydrological frequency approval letter to the ULS and submits the final application to the FCC.

When the applicant receives Federal hydrological frequency approval, he/she must log in to the ULS and do the following:

- Click the "Attachment" button (located at the bottom of the screen). Upload both the Federal hydrological frequency request and approval letters to the ULS. All uploads should be in PDF.
- File the application by clicking "Submit" on the ULS application. NOTE: Do not use the "Batch File/Submit Pack" button that is visible after logging in; this will not produce a successful submission.

After the applicant has submitted each FCC application, the ULS will display a confirmation page (Figure B-10). Record the file number for future reference. If the ULS does not display a confirmation page, contact the FCC at 1-888-225-5322, option 2, for assistance about how to proceed.

**Federal Communications Commission**

**ULS Online Filing**

**Application Confirmation**

---

Application has been submitted. The file number for this application is 0001362800.

Return      ?      Print Preview  
ULS Home      Ownership      Login

File Number	Payment Type Code	Quantity	Subtotal
No application or regulatory fees are required			

Before leaving this page, you must click and print the 159 Form to attach to your payment to ensure proper fee association and to avoid possible dismissal of this application.

If you have fees due for this filing, mail or deliver FCC Form 159 along with payment for the amount denoted in Form 159 Box 3 to:

Federal Communications Commission  
P. O. Box 358994  
Pittsburgh, PA 15251-5994

*The Form 159 and accompanying fee must be received by the Commission within 10 days of filing the application.*

If you believe the calculated fee is incorrect, please call 1-888-CALLFCC and go to option #2 for assistance.

Form 159      Fees Help

Figure B-10. "Application Confirmation"

### 3. Modifying Existing Licenses

Applicants can use the ULS for all license modifications for associated call signs as follows:

- Phase I – Determine the type of modification
- Phase II—Create a modification application in the ULS
- Phase III—Enter license modifications into the ULS

- Phase IV—Use the draft application to generate a request for Federal hydrologic radio frequency approval
- Phase V—Attach the Federal hydrologic radio frequency approval to the ULS draft, and file it as a completed FCC application.

**IMPORTANT PRECAUTIONS:**

- Do not submit the information as a final application until Federal hydrologic frequency approval is received. (See section 2.5)
- Re-access all draft ULS applications at least once every 30 days, and click on the Check Errors button. (See section 2.2).

**3.1 Phase I - Determine the Type of Modification**

If the license modification is an Administrative Update (see glossary), then skip to Phase IV and do not submit attachments with the application. If the change to the license is a major filing (see glossary), then you will need to complete all the phases.

**3.2 Phase II - Create a Modification Application in the ULS**

- Log in to the ULS.
- Select the "New Filing" button.
- Within the "Purpose of Application", select "Modification" or "Renewal/Modification."
- When presented with the list of call signs, select the desired call sign, then click "Continue."
- Wait for the ULS application to appear.

**3.3 Phase III - Enter License Modifications Into The ULS**

This phase consists of entering the applicant's license changes into the ULS. Some of the existing license information will automatically be downloaded and editable. Applicants should proceed completing the application in the following order:

3.3.1 Application Information Tab

In the "Application Information" tab shown in Figure B-11, the shaded boxes are auto-filled. The editable fields (non-shaded) should have the following information filled-in. Use "Check Errors" when finished.

NOTE: The editable information should be filled-in as shown in the sample application below:

Administrative	Location	Antenna	Frequency
Application Information	Applicant	Ownership Questions/Qualification Questions	General Certification Statements
			Control Point
<p><b>FCC 601</b>      <b>FCC Application for Wireless Telecommunications Bureau</b>      Approved by OMB</p> <p style="text-align: center;"><b>Radio Service Authorization</b>      3060-0798</p>			
<p><b>Application Purpose</b> <input type="text" value="MD"/>      Radio Service Code: <input type="text" value="PW"/>      File Number: <input type="text" value=""/>      Callsign: <input type="text" value="WPHF933"/></p>			
<p>If this request is for a Developmental License, Demonstration License, or a Special Temporary Authorization (STA), enter the code and attach the required exhibit as described in the instructions. Otherwise enter N (Not Applicable) <input type="text" value="N"/></p> <p>If this request is for Special Temporary Authority due to an emergency situation, enter 'Y'; otherwise enter 'N'. <input type="radio"/> Yes      <input type="radio"/> No</p> <p>If this request is for a New, Amendment, Renewal Only, or Renewal/Modification enter the requested authorization expiration date, MM/DD (this item is optional): <input type="text" value=""/></p> <p>Is this request "major" as defined in Section 1.929 of the Commission's Rules when read in conjunction with the applicable radio service rules found in Parts 22 and 90 of the Commission's Rules? (NOTE: This question only applies to certain site-specific applications. See the instructions for applicability and full text of Section 1.929). <input checked="" type="radio"/> Yes      <input type="radio"/> No</p> <p>Does this filing request a Waiver of the Commission's rules? If "Yes", attach an exhibit providing rule numbers and explaining circumstances. <input type="radio"/> Yes      <input checked="" type="radio"/> No      <input type="text" value=""/></p> <p>If a feeable waiver request is attached, multiply the number of stations (call signs) times the number of rule sections and enter the result. <input type="text" value=""/></p> <p>Are the frequencies or parameters requested in this filing covered by grandfathered privileges, previously approved by waiver, or functionally integrated with an existing station? <input type="radio"/> Yes      <input checked="" type="radio"/> No</p> <p>Are attachments being filed with this application? <input checked="" type="radio"/> Yes      <input type="radio"/> No</p>			
<p><b>Regulatory Status</b></p> <p>This filing is for authorization to provide or use the following type(s) of radio service offering (enter all that apply):</p> <p><input type="checkbox"/> Common Carrier      <input type="checkbox"/> Non-Common Carrier      <input checked="" type="checkbox"/> Private, internal communications      <input type="checkbox"/> Broadcast Services      <input type="checkbox"/> Band Manager</p>			
<p><b>Type of Radio Service</b></p> <p>This filing is for authorization to provide the following type(s) of radio service (enter all that apply):</p> <p><input checked="" type="checkbox"/> Fixed      <input type="checkbox"/> Mobile      <input type="checkbox"/> Radiolocation      <input type="checkbox"/> Satellite (sound)      <input type="checkbox"/> Broadcast Services</p> <p>Interconnected Service?      <input type="radio"/> Yes      <input checked="" type="radio"/> No</p>			
<p><b>Fee Status</b></p> <p>Is the Applicant exempt from FCC application fees?      <input checked="" type="radio"/> Yes      <input type="radio"/> No</p> <p>Is the Applicant exempt from FCC regulatory fees?      <input checked="" type="radio"/> Yes      <input type="radio"/> No</p>			
<p>Receipt Date (MM/DD/YY)</p> <p><input type="text" value="9/26/03"/></p>			
?	Login	Print Preview	Attachment
	Check Errors	Previous Page	Next Page
			Ownership

Figure B-11. Sample "Application Information" Tab

3.3.2 Applicant Tab

Figure B-12 shows the "Applicant" tabbed-panel based on sample data. Fill in any changes that are needed. Use the "Check Errors" button when finished.

Administrative	Location	Antenna	Frequency								
Application Information	Applicant	Ownership Questions/Qualification Questions	General Certification Statements								
Control Point											
<b>Applicant Information</b>											
FCC Registration Number (FRN)	XX06909964		The Licensee is a(n): Government Entity								
First Name:	MI:	Last Name:	Suffix:								
Entity Name: STATE EMERGENCY MANAGEMENT AGENCY											
Attention To: JOHN A. DOE											
P.O. Box:	Address: 321 RIDGEWAY BLVD.										
City:	State:	Zip: 20910									
Phone No.:	FAX:	E-Mail: JOHN.DOE@ATT.NET									
Name of Real Party in Interest (if different from applicant)	TIN of Real Party in Interest		Enter to retrieve RPI name								
<b>Name of Contact Representative (if different from the applicant)</b>											
First Name:	MI:	Last Name:	Suffix:								
Company:											
P.O. Box:	Address:										
City:	State:	Zip:									
Phone No.:	FAX:	E-Mail:									
<b>Race, Ethnicity, Gender of Applicant/Licensee (Optional)</b>											
Race	<input type="checkbox"/> American Indian or Alaska Native	<input type="checkbox"/> Asian	<input type="checkbox"/> Black or African-American								
	<input type="checkbox"/> Native Hawaiian or Other Pacific Islander	<input type="checkbox"/> White									
Ethnicity	Gender										
<table border="1"> <tr> <td>?</td> <td>Login</td> <td>Print Preview</td> <td>Attachment</td> <td>Check Errors</td> <td>Previous Page</td> <td>Next Page</td> <td>Ownership</td> </tr> </table>				?	Login	Print Preview	Attachment	Check Errors	Previous Page	Next Page	Ownership
?	Login	Print Preview	Attachment	Check Errors	Previous Page	Next Page	Ownership				

Figure B-12. Sample "Applicant" Tab

3.3.3 Ownership/Qualification Tab

Answers to the questions displayed in Figure B-13 below are required and will likely be the same as on the original license.

Administrative		Location	Antenna	Frequency
Application Information	Applicant	Ownership Questions/Qualification Questions		General Certification Statements   Control Point
<b>Alien Ownership Questions (If any answer is Yes, attach exhibit explaining circumstances.)</b>				
Is the applicant a foreign government or the representative of any foreign government?				No
Is the applicant an alien or the representative of an alien?				No
Is the applicant a corporation organized under the laws of any foreign government?				No
Is the applicant a corporation of which more than one-fifth of the capital stock is owned of record or voted by aliens or their representatives or by a foreign government or representative thereof or by any corporation organized under the laws of a foreign country?				No
Is the applicant directly or indirectly controlled by any other corporation of which more than one-fourth of the capital stock is owned of record or voted by aliens, their representatives, or by a foreign government or representative thereof, or by any corporation organized under the laws of a foreign country?				No
<b>Basic Qualification Questions (If any answer is Yes, attach exhibit explaining circumstances.)</b>				
Has the applicant or any party to this application or amendment had any FCC station authorization, license, or construction permit revoked or had any application for an initial, modification or renewal of FCC station authorization, license, construction permit denied by the Commission?				No
Has the applicant or any party to this application or amendment, or any party directly or indirectly controlling the applicant, or any party to this application ever been convicted of a felony by any state or federal court?				No
Has any court finally adjudged the applicant or any party directly or indirectly controlling the applicant guilty of unlawfully monopolizing or attempting unlawfully to monopolize radio communication, directly or indirectly, through control of manufacture or sale of radio apparatus, exclusive traffic arrangement, or any other means or unfair methods of competition?				No
Is the applicant or any party directly or indirectly controlling the applicant, currently a party in any pending matter referred to in the preceding two items?				No
?	Login	Print Preview	Attachment	Check Errors
			Previous Page	Next Page
Ownership				

Figure B-13. Sample "Ownership Questions/Qualification Questions" Tab



3.3.4 General Certification Tab

The contact person who is responsible for the contents of the application must type in his/her name and title, as shown in Figure B-14. The signature field will automatically be filled in with this person's name.

Administrative	Location	Antenna	Frequency
Application Information	Applicant	Ownership Questions/Qualification Questions	General Certification Statements
			Control Point

**General Certification Statements**

The applicant waives any claim to the use of any particular frequency or of the electromagnetic spectrum as against the regulatory power of the United States because of the previous use of the same, whether by license or otherwise, and requests an authorization in accordance with this application.

The applicant certifies that grant of this application would not cause the applicant to be in violation of any pertinent cross-ownership, attribution, or spectrum cap rule.<sup>5</sup>

\*If the applicant has sought a waiver of any such rule in connection with this application, it may make this certification subject to the outcome of the waiver request.

The applicant certifies that all statements made in this application and in the exhibits, attachments, or documents incorporated by reference are material, are part of this application, and are true, complete, correct, and made in good faith.

The applicant certifies that neither the applicant nor any other party to the application is subject to a denial of Federal benefits pursuant to Section 5301 of the Anti-Drug Abuse Act of 1988, 21 U.S.C § 862, because of a conviction for possession or distribution of a controlled substance. This certification does not apply to applications filed in services exempted under Section 1.2002(c) of the rules, 47 CFR § 1.2002(c). See Section 1.2002(b) of the rules, 47 CFR § 1.2002(b) for the definition of 'party to the application' as used in this certification.

The applicant certifies that it either (1) has a current Form 602 on file with the Commission, (2) is filing an updated Form 602 simultaneously with this application, or (3) is not required to file Form 602 under the Commission's rules.

The applicant certifies that the facilities, operations, and transmitters for which this authorization is hereby requested are either: (1) categorically excluded from routine environmental evaluation for RF exposure as set forth in 47 C.F.R. § 1.1307(b); or, (2) have been found not to cause human exposure to levels of radiofrequency radiation in excess of the limits specified in 47 C.F.R. § 1.1310 and 2.1093; or, (3) are the subject of one or more Environmental Assessments filed with the Commission.

**Typed or Printed Name of Party Authorized to Sign:**

First Name:  MI:  Last Name:  Suffix:

Title:

Signature:

**Upon grant of this license application, the licensee may be subject to certain construction or coverage requirements. Failure to meet the construction or coverage requirements will result in termination of the license. Consult appropriate FCC regulations to determine the construction or coverage requirements that apply to the type of license requested in this application.**

**WILLFUL FALSE STATEMENTS MADE ON THIS FORM OR ANY ATTACHMENTS ARE PUNISHABLE BY FINE AND/OR IMPRISONMENT (U.S. Code, Title 18, Section 1001) AND/OR REVOCATION OF ANY STATION LICENSE OR CONSTRUCTION PERMIT (U.S. Code, Title 47, Section 312(a)(1)), AND/OR FORFEITURE (U.S. Code, Title 47, Section 503).**

?	Login	Print Preview	Attachment	Check Errors	Previous Page	Next Page	Ownership
---	-------	---------------	------------	--------------	---------------	-----------	-----------

Figure B-14. Sample "General Certification Statements" Tab

3.3.5 Control Point Tab

A Control Point may be defined as the administrative office that is responsible for maintenance of the transmitters and/or the receiver point (see glossary). Figure B-15 shows an application after one Control Point has been added.

- At least one control point must be listed.
- Multiple Control Points can be listed on a license.
- The maximum number of locations that can be associated to a single control point is 20.

Select the Control Point that is to be modified, and click "Modify". Use the "Add" button to create additional Control Points or the "Delete" button for removing Control Points.

Administrative	Location	Antenna	Frequency
Application Information	Applicant	Ownership Questions/Qualification Questions	General Certification Statements
Control Point			
<p>Select Control Point</p> <div style="border: 1px solid gray; padding: 2px;"> <p>1 LYCOMING CTY EM</p> </div> <p style="text-align: right;">Action: <input type="button" value="M"/></p>			
<input type="button" value="Add"/> <input type="button" value="Modify"/> <input type="button" value="Delete"/> <input type="button" value="Save"/> <input type="button" value="Clear"/>	<p>Address: <input type="text" value="1234 COURTHOUSE LANE"/></p> <p>City or Town: <input type="text" value="ANYTOWN"/> State: <input type="text" value="PA"/></p> <p>County: <input type="text" value="Sullivan"/></p> <p>Phone Number: <input type="text" value="(717) 555-2334"/></p>		
?	Login	Print Preview	Attachment
	Check Errors	Previous Page	Next Page
		Ownership	

Figure B-15. Sample “Control Point” Tab

3.3.6 Administrative Tab

Use rule section 90.173c for the application, as shown in Figure B-16. The "Describe Activity" text box should be completed with a description similar to "Collect hydrologic data in cooperation with Federal government. See attached letter of approval". Section 2.5 provides more information about this attachment. The Frequency Coordinator Section is not editable, nor does it apply.

Answer the question about "Extended Implementation" and click "Check Errors".

Application Information	Applicant	Ownership Questions/Qualification Questions	General Certification Statements	Control Point
Administrative		Location	Antenna	Frequency

**Eligibility**

Rule Section: 90.173c

Describe Activity: <State your intended usage>

---

**Frequency Coordinator Information (if not self-coordinated)**

Freq Coordination #

Name of Freq Coordinator

Other

Telephone Number

Coordination Date

Has this application been successfully coordinated?

---

**Extended Implementation (Slow Growth)**

Are you requesting a new or modified extended implementation plan? No

If "Yes", attach an exhibit with a justification and a proposed station construction schedule.

---

**Associated Call Signs**

Select Call Sign #	Action	Call Sign	
WPHF929		WPHF929	Add Call Sign
WPHF933			Modify Call Sign
WPHF937			Delete Call Sign

Save Call Sign

Clear Call Sign

---

**Broadcast Auxiliary Only**

Is there an associated Parent Station?

Facility Id of Parent Station

Radio Service of Parent Station

City of Parent Station Principal Community

State of Parent Station Principal Community

If there is no associated parent station, this application is a

State of Primary Operation

---

?	Login	Print Preview	Attachment	Check Errors	Previous Page	Next Page	Ownership
---	-------	---------------	------------	--------------	---------------	-----------	-----------

Figure B-16. Sample "Administrative" Tab

3.3.7 Location Tab

Figure B-17 shows the location tab. Follow these steps to modify a station:

- Select a location and then click "Modify".
- Make the changes to the station as shown below.
- Use the "Save" button at the top of the form when you are done.
- Click "Add" to add another location (up to 6 total) or "Delete" to remove a location. Then provide the information in the editable fields. Use the FCC's TOWAIR Determination at <http://wireless2.fcc.gov/UlsApp/AsrSearch/towairSearch.jsp> to assure no Antenna Structure Registration (ASR) is necessary. (See glossary.)

Click the "Save" button before attempting to add another location.

Administrative	Location	Antenna	Frequency																
Select Location																			
<table border="1"> <tr><td>1</td><td>Fixed</td><td>41-29-29.8N</td><td>76-36-9.3W</td></tr> <tr><td>2</td><td>Fixed</td><td>41-21-25.0N</td><td>76-32-6.0W</td></tr> <tr><td>3</td><td>Fixed</td><td>41-18-51.8N</td><td>76-38-48.5W</td></tr> <tr><td>4</td><td>Fixed</td><td>41-14-17.5N</td><td>76-43-5.4W</td></tr> </table>		1	Fixed	41-29-29.8N	76-36-9.3W	2	Fixed	41-21-25.0N	76-32-6.0W	3	Fixed	41-18-51.8N	76-38-48.5W	4	Fixed	41-14-17.5N	76-43-5.4W	<input type="button" value="Add"/> <input type="button" value="Save"/> <input type="button" value="Modify"/> <input type="button" value="Delete"/> <input type="button" value="Clear"/>	
1	Fixed	41-29-29.8N	76-36-9.3W																
2	Fixed	41-21-25.0N	76-32-6.0W																
3	Fixed	41-18-51.8N	76-38-48.5W																
4	Fixed	41-14-17.5N	76-43-5.4W																
Action	Location Description	Area of Operation Code	Location Name																
A	F Fixed																		
FCC Antenna Structure Registration # or N/A (FAA Notification not Required)		Registration Number Press Enter to retrieve Tower data	Latitude (DD-MM-SS.S) Longitude (DDD-MM-SS.S)																
N/A			41-29-29.8 N 076-36-09.3 W																
Street Address, Name of Landing Area, or Other Location Description		City	State																
NE corner of the SR87 bridge across Loyalsock Creek		Hillsgrove	PA																
County		Elevation of Site AMSL (meters) (*' in antenna structure example):	Overall Ht AGL without appurtenances (meters) (*' in antenna structure example): Overall Ht AGL with appurtenances (meters) (*' in antenna structure example):																
Sullivan		309.0	4.1 4.3																
Support Structure Type	PIPE Any type pipe																		
Location Number: (only for Area of Operation Code 'A')	Temporary Fixed or Mobile Radius (km)	Airport Identifier	Site Status																
Maximum Latitude (DD-MM-SS.S) Use for rectangle only (Northwest corner) NAD 83 N or S	Maximum Longitude (DDD-MM-SS.S) Use for rectangle only (Northwest corner)	Do you propose to operate in an area that requires frequency coordination with Canada?																	
Description (only for Area of Operation Code 'D')																			
Number of Units	Hand Held	Mobile	Temporary Fixed Aircraft Itinerant																
Would a Commission grant of Authorization for this location be an action which may have a significant environmental effect? See Section 1.1307 of 47 CFR. If 'Yes', submit an environmental assessment as required by 47 CFR, Sections 1.1308 and 1.1311																			
No																			
If the proposed site is located in one of the quiet zones listed in Item 27 of the Instructions, provide the date (mm/dd/yy) the proper authority was notified																			
? Login	Print Preview	Attachment	Check Errors																
Previous Page		Next Page																	
Ownership																			

Figure B-17. Sample "Location" Tab

3.3.8 Antenna Tab

To change information for an antenna, do the following:

- Click Select Location
- Modify >> Make the information changes
- Click Save

Check for errors before selecting/changing another location. Refer to the Glossary for definitions of the antenna terms in this form. Figure B-18 below shows Antenna # 3 selected for modification.

Application Information	Applicant	Ownership Questions/Qualification Questions	General Certification Statements	Control Point																			
Administrative		Location	Antenna	Frequency																			
<p>Select Location</p> <table border="1"> <tr><td>1</td><td>41-19-1.3N</td><td>77-20-38.9W</td></tr> <tr><td>2</td><td>41-20-21.3N</td><td>76-46-41.8W</td></tr> <tr style="background-color: #d3d3d3;"><td>3</td><td>41-35-40.3N</td><td>76-35-36.8W</td></tr> <tr><td>4</td><td>41-24-50.2N</td><td>77-29-43.9W</td></tr> <tr><td>5</td><td>41-31-7.3N</td><td>77-17-21.9W</td></tr> <tr><td>6</td><td>41-26-20.3N</td><td>76-40-18.8W</td></tr> </table>		1	41-19-1.3N	77-20-38.9W	2	41-20-21.3N	76-46-41.8W	3	41-35-40.3N	76-35-36.8W	4	41-24-50.2N	77-29-43.9W	5	41-31-7.3N	77-17-21.9W	6	41-26-20.3N	76-40-18.8W	<p>Select Antenna</p> <table border="1"> <tr><td>1</td></tr> </table>	1	<p>Add</p> <p>Modify</p> <p>Save</p> <p>Delete</p> <p>Refresh</p> <p>Clear</p>	
1	41-19-1.3N	77-20-38.9W																					
2	41-20-21.3N	76-46-41.8W																					
3	41-35-40.3N	76-35-36.8W																					
4	41-24-50.2N	77-29-43.9W																					
5	41-31-7.3N	77-17-21.9W																					
6	41-26-20.3N	76-40-18.8W																					
1																							
Action:		<input type="text"/>																					
AAT(meters)		<input type="text"/>																					
Antenna Ht. (meters)		<input type="text" value="4.0"/>																					
Azimuth (degrees)		<input type="text"/>																					
Beamwidth (degrees)		<input type="text"/>																					
Polarization		<input type="text"/>																					
Gain (dB)		<input type="text"/>																					
?	Login	Print Preview	Attachment	Check Errors																			
			Previous Page	Next Page																			
Ownership																							

Figure B-18. Sample "Antenna" Tab

3.3.9 Frequency Tab

"Frequency" is the final tab, shown in Figure B-19. Select:

- Location number >> Antenna number >> Frequency
- Make the frequency changes, then use "Save" before selecting another location.

Note that each frequency for each antenna/frequency combination has its own emission designator.

Application Information		Applicant		Ownership Questions/Qualification Questions		General Certification Statements		Control Point	
Administrative			Location		Antenna		Frequency		
Select Location 1 41-19-1.3N 77-20-38.9W 2 41-20-21.3N 76-46-41.8W 3 41-35-40.3N 76-35-36.8W 4 41-24-50.2N 77-29-43.9W 5 41-31-7.3N 77-17-21.9W			Select Antenna 1		Select Frequency 00169.45000		Add Freq    Clear Freq Modify Freq    Delete Freq Save Freq		
Freq Action		Lower or Center Frequency (MHz)		Upper Frequency (MHz)		Frequency Carrier (MHz)			
		169.45							
Station Class		No. of Units		No. of Paging Receivers		Output Power (watts)		ERP (watts)	
FXO		1				25.000		50.000	
Select Emission									
1 8K00F2D			Emission Action		Emission Designator		Add Emission Delete Emission Save Emission Clear Emission Modify Emission		
					8K00F2D				
Refresh									
?	Login	Print Preview	Attachment	Check Errors			Previous Page	Next Page	Ownership

Figure B-19. Sample "Frequency" Tab

### 3.4 Phase IV - Submit Exported ULS Information for Federal Approval

Refer to Section 2.5 and follow the instructions given to submit information.

### 3.5 Phase V - Complete and File the ULS Application

Refer to Section 2.6 and follow the steps to complete the filing.

## 4. Renewing Existing Licenses

License renewals can be done through the ULS for associated call signs. The FCC notifies license holders by mail approximately 90 days prior to license expiration, but applicants are held responsible for renewing in time. Before renewing, applicants should reapply for hydrologic radio frequency approval as described in Section 2.5, and attach it to the license renewal.

To renew a license, perform the following steps:

- Log in to the ULS
- Select the "New Filing" button.
- For "Purpose of Application", select "Renewal Only".
- Select the desired call sign(s), read over the certification statements, fill out the signature information fields, and then click the "Renew" button.

The renewal application is typically processed within 30 days.

### 4.1 Canceling An Existing License

Applicants may cancel their licenses through the ULS for associated call signs. To cancel a license, perform the following steps:

- Log in to the ULS.
- Select the "New Filing" button.
- For "Purpose of Application", select "Cancellation of License."
- Select the desired call sign(s), read over the certification statements, fill out the signature information fields, and then click the "Cancellation" button.

## 5. Glossary

The glossary contains a list of technical terms and definitions used in this appendix.

**AAT** - Abbreviation for "Above Average Terrain," measured in meters.

**Administrative Update** - An application filing that allows a licensee to update administrative data on its license(s) in the ULS licensing database. (Previously, applicants made administrative updates with a formal FCC modification request or an informal letter request.) Administrative changes are limited to changes in licensee name (provided there is no change in license ownership, control, or corporate structure), address, phone number, fax number, control point, e-mail address, and point of contact information. Administrative changes do not include changes in technical specifications to a license, control points, assignments or transfers, or other changes that would require a modification application. (See Modification.)

**Antenna Structure Registration (ASR)** - As part of its ongoing effort to promote air safety, the FCC requires owners to register certain antenna structures (generally those more than 60.96 meters (200 feet) in height or located near an airport) with the Commission.

**Associated Call Sign** - Call signs are considered by the FCC to be "associated" if they are linked with an FRN within the online ULS system. If the call sign was obtained before December 2001, the license call sign may not be explicitly associated with an FRN since the TIN may not have been provided. Only call signs associated with an FRN may be revised using the ULS.

**Attachment** --There is a Yes/No question in the ULS application regarding whether the application includes attachments. An application for a new license or a request to modify an existing license will likely require submission of attachments pertaining to Federal hydrologic radio frequency approval. Applicants are required to upload and submit Federal hydrologic radio frequency requests and approvals as attachments. The FCC accepts Word Documents and text files as attachments, but it is strongly advised that all attachments be in Adobe Acrobat PDF format.

**Azimuth**--The direction that the transmitter faces relative to its receiver relative to true north. Azimuth angles can thus range from 0 degrees (north) through 90 (east), 180 (south), 270 (west), and up to 360 (north again).

**Beamwidth** - an angular measure of the main lobe (or main beam) in either (or both) the horizontal-plane or vertical-plane pattern. There are several definitions for beamwidth. The half-power, or 3 dB, beamwidth is most commonly used. Consult transmitter technical specifications to determine the narrowest acceptable antenna beamwidth for use.

**Call Sign** - The combination of letters and numbers that serve to identify an FCC license.

**Control Point**--A common point (e.g. administrative office) that monitors or uses data transmitted from the locations listed on the license. The control point is usually responsible for maintenance of the locations

**Draft** - An application within the ULS that has some or all input screens completed, but the user has not submitted the data by clicking the "Submit" button.

**EIN** - The IRS identification (also known as TIN) number for a business, non-profit, or government agency. An agency's payroll department will generally provide the agency's EIN.

**Emission Designator** - A combination of symbols that designate transmitter bandwidth, modulation, nature of signal, and type of information. Emissions are classified and symbolized according to the following characteristics:

**First Symbol** - antenna bandwidth.

**Second Symbol** - type of modulation of the main carrier.

**Third Symbol** - nature of signal(s) modulating the main carrier.

**Fourth Symbol** - type of information to be transmitted.



**ERP (Effective Radiated Power)** - The power supplied to an antenna multiplied by the antenna gain in a given direction. If the direction is not specified, the direction of maximum gain is assumed.

**Export to PDF** - The conversion of a file from a native format (e.g., html, MS Word, MS Powerpoint, etc.) into Adobe Acrobat PDF format. A PDF file can be opened by any user that has Acrobat Reader.

**Fixed Location** - An antenna that is permanently mounted. A land mobile station is an example of a station that is not fixed.

**FRN** - Before using ULS, applicants have to first register with the FCC's Commission Registration System (CORES) to receive an FCC Registration Number (FRN). If an applicant previously registered with CORES, the applicant will already have an FRN.

**Gain** - The ratio of output current, voltage, or power to input current, voltage, or power, respectively. Gain is usually expressed in dB.

**Html** - The language used to create web pages for display in browsers.

**Location** - Term used by the FCC to refer to a transmitting station.

**Low Power** - a transmitter whose operational power usage is kept to a minimum; typically 25 watts or less.

**Major Filing** - An amendment to an application or a request for modification of license that is defined as "major" in Part 1 of the Commission's rules. Examples of major filings are new applications, extension of time requests, and modifications to technical information.

**Minor Filing** - An amendment to an application or a request for modification of license that is defined as "minor" in Part 1 of the Commission's rules. In general, any change not defined as major is considered minor. Examples of minor filings are duplicate license, withdrawal, and cancellation.

**Modification** - An applicant's request to change the terms, conditions, or specifications of an existing license, other than administrative changes. (See Administrative Update.) Modifications may be major or minor. (See Major Filing and Minor Filing.)

**Network Drawing** - The network drawing must show the proposed and existing stations that are part of the network. Existing stations are previously-licensed sites that are operational. Each type should be noted as such. Network connectivity should also be depicted. Upon completion, the drawing needs to be converted to Adobe PDF format.

**Password** - A password is assigned upon sign-up in the Federal Communications Commission Registration System (CORES). The user should save a printout of their FRN and password during registration. The password has to be 6 to 15 characters long and is case-sensitive. Applicants should use a password hint that does not contain the actual password itself. If an applicant forgets his/her password or has other password-related questions, the FCC technical support team should be contacted at 877-480-3201 or [CORES@fcc.gov](mailto:CORES@fcc.gov).

**PDF Printer Driver** - A printer that can be selected when a user wants to create PDF files from a software application. PDF printer drivers are available only when Adobe Acrobat software has been installed.

**Polarization** - The property that describes the antenna orientation. Use the following codes when polarization into a licensing application:

- E – Elliptical
- F - 45 degrees
- H – Horizontal
- J – Linear
- L - Left-hand circular
- R - Right-hand circular
- S - Horizontal and vertical
- T - Right and left-hand circular
- V – Vertical
- X - Other (provide a description in an attachment)

**Quiet Zone** - A rectangular area which is located within Virginia, West Virginia, and Garrett County, Maryland and bounded by 39 degrees 15' N on the north, 78 degrees 30' W on the east, 37 degrees 30' N on the south, and 80 degrees 30' W on the west. On February 25, 1997, the National Weather Service IFLOWS program received authority to operate transmitters, assuming locations use the lowest possible power. As of the writing of this document, the National Radio Astronomy Observatory (NRAO) still acknowledges this letter as proper authorization. For further information, contact Denise Wirt of the NRAO at (304) 456-2107.

**Renewal** - A grant to a licensee of an additional license term at the conclusion of the current license term. To obtain a renewal, licensees is required to file a renewal application on or before the current license expiration date.

**TIN (Taxpayer Identification Number)** - The identification number the Internal Revenue Service associates with individuals and organizations. For individuals, the TIN is their social security number and for businesses and governmental organizations, it is usually their EIN.

**TOWAIR** - A tool on the ULS website that allows the user to input antenna information and location coordinates for the purpose of determining if Antenna Structure Registration is required. TOWAIR can be found by clicking [here](#).

**Universal Licensing System (ULS)** - The ULS is browser-based system for allowing electronic radio frequency licensing. The system will dynamically create a screen that will ask only for the information that is needed.

**Appendix C Sample Letter to AFWS Owner Indicating Need to Obtain FCC License**

The sample wording shown below may be used to contact the AFWS point of contact by regular or electronic mail. Before sending this letter, please refer to Section 4.8 Special Procedures for Transitioning Licenses from NWS to non-NWS Entities, and obtain necessary technical information about the transmitters. It is also advisable to verbally or personally contact the affected parties so that they are aware of the reasons for the NWS request.

(AFWS Point of Contact)

(AFWS Organization Name)

(AFWS Organization Address)

(AFWS Organization City and State)

Dear (AFWS Point of Contact):

Our records indicate that (AFWS Organization Name) is the owner of radio transmitters listed in Attachment 1. (attachment 1 is the list of NWS radio frequency assignments believed to be owned by the addressee).

These transmitters have been licensed by the National Telecommunications and Information Administration (NTIA) to the National Weather Service (NWS) for operation on government hydrologic radio frequencies of (enter frequencies here). Our information indicates that these transmitters are still in use and were originally licensed in (enter year of issue here).

NWS has determined that it can no longer hold licenses for these transmitters, because it neither operates nor maintains them, and therefore cannot assure the NTIA that the transmitters comply with the laws governing their operation. Therefore, if you wish to continue using these transmitters for hydrometeorological data collection, it will be necessary for you to directly obtain licenses from the Federal Communications Commission (FCC), and to verify equipment compliance with current licensing requirements. The FCC does not assess fees for these licenses, nor are there any frequency coordination fees for use of Federal hydrologic frequencies. NWS regrets the additional workload the FCC filing may cause upon your organization, and recognizes the value of the data your transmitters provide. To assist in this transition, we have developed information on how to obtain an FCC license for transmitters on Federal frequencies. A printable version of the guide may be found online at online at [http://afws.erh.noaa.gov/afws/Hydro\\_Freq\\_Lic\\_Guide.pdf](http://afws.erh.noaa.gov/afws/Hydro_Freq_Lic_Guide.pdf). A presentation of a workshop on the licensing process may be found online at <http://afws.erh.noaa.gov/afws/workshop.php>. Information about how to file with the FCC can be found at <http://wireless.fcc.gov/uls/>. If further assistance is necessary, please email your request to [Hydro.Radio.Freq@noaa.gov](mailto:Hydro.Radio.Freq@noaa.gov).

Sincerely,

(Appropriate NWS Official)

## Appendix D Response Planning Guidance

### 1. Introduction

An effective flood warning system requires a community response plan that includes written procedures that will help to reduce loss of life and property. The plan should include elements of:

- Warning Dissemination
- Evacuation and Rescue
- Damage Reduction
- Recovery
- Public Information
- Plan Implementation
- Plan Maintenance

### 2. Warning Dissemination

Planning Objective: To disseminate timely, accurate, and reliable warnings that address the following items.

- Ensure prompt attention to information concerning flood threats
- Specify what types of warnings are issued for various possible conditions
- Ensure that product content is commensurate with the expected severity of the flood
- Ensure that the NWS warnings are disseminated to need-to-know individuals in a timely manner
- Ensure that locally generated advisories are coordinated with NWS

#### 2.1 Warning Dissemination Identification Task

- Identify special recipients who are to be notified under various possible conditions of flood threat
- Describe the means of communications to be used in alerting each special recipient
- Specify record keeping, acknowledgment, and other processes to assure notices are given and received

#### 2.2 Warning Dissemination Procedures Development Task

- Adequately ensure affected persons receive timely warnings notwithstanding telephone and power failures
- Provide various warnings according to seriousness of flood threat
- Specify the conditions about the means of warning dissemination will be used
- Describe how parties responsible for dissemination are instructed to begin distributing warnings
- Consider the time of day, day of week, or seasonal factors affecting the means of warning dissemination

### 3. Evacuation and Rescue

Planning Objective: To prevent the loss of life due to flooding or to flood-related causes.

### 3.1 Evacuation Area Identification Task

Identify areas that will be inundated at each potential level of flooding due to:

- Overbank flows
- Entry of floodwaters through sewers, drainage channels, etc.
- Internal drainage or ponding unrelated to flood height in streams
- Identify areas requiring evacuation for reasons other than inundation including:
  - Loss of access or escape routes
  - Loss or curtailment of utility or other emergency services
  - Site-specific problems

### 3.2 Evacuation Procedures Development Task

Select evacuation destinations for each area to be evacuated which are:

- Safe from flooding and other related hazards
- Easily identified to the public
- Within time and distance commensurate with the warning time
- Suitable for use for the expected duration of flooding

Identify best available evacuation routes which are:

- Safe from early flooding due to urban drainage or other impediments;
- Passable in all weather
- Adequate to handle expected traffic

Establish priorities for evacuation which take into account:

- Time of flooding with respect to other areas
- Severity of flooding
- Loss of escape routes

Establish procedures for carrying out evacuation which are consistent with the warning time available including:

- Ensuring that the affected public is advised of the need to evacuate, safe destinations, routes, and time available for evacuation
- Providing general assistance in transportation and in preparing homes and businesses for evacuation
- Providing special assistance to those having unusual evacuation needs;
- Assuring evacuation is complete
- Establishing traffic controls to prevent accidental entry into dangerous areas, identifying evacuation routes, and facilitating evacuation traffic
- Establishing surveillance over the evacuation area to ensure safety of the area.

### 3.3 Reception Center Operations Task

Estimate the duration, damage, and population affected in the case of a severe flood and determine reception center requirements including:

- Number of evacuated persons likely to require emergency overnight housing
- Number of meals to be served
- Type and extent of medical or other care that may be required
- Required services, equipment, and supplies for operation
- Required personnel for operation

Select reception centers which meet the following:

- Safe under conditions of severe flooding
- Have or can be provided with necessary equipment and services
- Provide sufficient space for required activities
- Available on short notice for the required duration
- Are readily identifiable to the public and accessible from all areas

Establish procedures for the operation of reception centers including:

- Basis on which reception center operations will be activated and terminated
- Source and means of providing necessary supplies, equipment, and services
- Allocation of space for reception center functions
- Provision of temporary assistance and information on long-term recovery aid

### 3.4 Emergency Action Task

Evaluate flooded areas related to the types of emergency activities including:

- Emergency evacuation of persons from dangerous areas
- Emergency provision of medical attention, fire control, or other assistance
- Emergency operation or curtailment of power, water, gas, and other services
- Control or containment of toxics, explosive gases, and other dangerous commodities
- Search for survivors

Determine requirements for conducting emergency actions including:

- Personnel
- Transportation
- Heavy-duty equipment (e.g., boats, trucks, earthmovers, and others)
- Portable hand tools and other equipment.

Establish procedures for carrying out emergency actions including:

- Organization of rescue squads
- Placement of personnel and equipment for conducting emergency activities
- Coordination arrangements for identifying needs for assistance and responding to calls
- Maintenance of communications

#### 4. Damage Reduction Element

Planning Objectives: To reduce public and private property damages from flooding or flood-related causes.

##### 4.1 Flood-Fighting Task

Identify needed flood-fighting actions to reduce overflow, seepage, and other types of flooding as well as erosion due to floodwaters including:

- Assuring floodgates or sewer outlets are closed
- Temporary heightening of levees or floodwalls;
- Securing of openings in levees and other embankments
- Containing overflows through manholes and other openings in the sewer system
- Pumping of internal drainage waters and
- Control of erosion at bridges, levees, building foundations, and roadway embankments

Establish flood-fighting procedures to control overflow, seepage, or other types of flooding with respect to:

- Locations where each action is to be carried out
- Maintaining surveillance to determine the need for personnel, equipment, and further actions
- Priority for accomplishment and
- Extent of action required for various flood heights.

Establish procedures for the evacuation or temporary removal and relocation of automobiles, furniture, valuables, clothes, business and personal records, machinery, and other movable property to reduce damage including:

- Identification of types of action required at various locations and expected flood heights
- Arrangements for the provision of labor and transportation assistance
- Identification of safe locations for storage of property

##### 4.2 Utility Management Task

Establish procedures for the curtailment of utility services to flooded areas including:

- Need for curtailment by area or individual property for each flood height
- Means for accomplishing curtailment (i.e., homeowner, utility staff, or other)
- Preparations to be made by property owner (within allowable time) prior to evacuation to minimize damage and facilitate the eventual return of services

Establish utility operation procedures to be used immediately prior to and during floods to:

- Minimize losses and risks caused by damaged utility systems
- Reduce damage done to utility equipment, supplies, and operational capabilities
- Maintain necessary utility services to vital community facilities

#### 4.3 Traffic Control Task

- Identify needs for traffic control prior to, during, and immediately after floods including:
- Preventing accidental travel in areas which are or will be flooded
- Establishing evacuation routes and speeding evacuation traffic
- Facilitating access to evacuation areas for transportation, rescue, and other essential traffic
- Preventing use of damaged roadways and bridges and
- Controlling access to damaged areas.

Establish procedures for traffic control which:

- Identify areas to be controlled at each expected flood height
- Specify locations where traffic control is to be established
- Identify detours or types of control to be effected
- Specify placement of personnel, barricades, and signs to effect necessary control and means of enforcement
- Restrict access to flood-damaged areas to residents and other authorized persons.

#### 4.4 Maintenance of Vital Services Task

Identify police, fire, medical, and other vital community services and facilities with respect to:

- Location
- Vulnerability to interference by inundation, loss of access, or communications
- Interdependencies on other services and facilities including utilities
- Temporary flood proofing or other actions required to prevent the loss of service or function
- Need for and means of providing auxiliary power, heat, water, sewage disposal, and other services necessary for continued operation of vital facilities.

Establish operational procedures for police, fire, utility repair, rescue, medical, and other services prior to and during floods including:

- Placement of equipment and personnel to prevent loss of access due to flooding of roads and underpasses or failure of bridges
- Means of relaying calls for assistance and coordinating responses
- Alternate routes for entering areas where traffic is controlled and avoiding evacuation routes

Establish procedures for evacuation or protection of important records and documents located in areas subject to flooding including those relating to:

- Vital statistics
- Tax and payroll information
- Court records
- Utility records
- Property ownership



- Business records

## 5. Recovery Element

Planning Objectives: To initiate and carry out post-flood actions to maintain public health, return community services to normal at the earliest possible time, provide aid, and assist in recovery operations.

### 5.1 Maintenance of Public Health Task

Establish procedures for handling of the dead including:

- Morgue location and method of operation
- Handling of personal effects and
- Identification and release of bodies.

Establish procedures for actions to preserve public health including:

- Provision of emergency medical services and care for injured persons
- Procedure for locating missing persons and providing information to friends and relations
- Collection and destruction of contaminated foodstuffs
- Disinfection of private water supply sources and systems
- Inoculations and other preventive medical care
- Disease control
- Control of insects, rodents, and other pests.

### 5.2 Return of Services Task

Establish procedures for actions to resume provision of utility services including:

- Preparations to be made by property owners
- System preparations including decontamination of water supplies
- Sequence for returning services
- Priority for resuming services

Establish procedures for returning to normal traffic patterns including:

- Evaluation of road and bridge safety
- Debris clearance
- Priority for providing access.

### 5.3 Rehabilitation and Repair Task

Establish procedures for post-flood cleanup including:

- Clearing, collecting, and disposing of debris and discarded goods
- Street washing
- Pumping basements
- Returning material previously relocated for safekeeping.

Establish procedures for management of damaged structures including:

- Procedures for identification and evaluation of damage and
- Demolition or temporary repair of hazardous buildings.

Identify the sources and programs for recovery assistance and the means of obtaining each including:

- Volunteer organizations
- Mutual aid agreements
- State assistance
- Federal assistance

Establish procedures for mobilizing assistance from each available source including:

- Conditions under which requests for assistance will be made
- Channels to be followed in requesting assistance
- Preparation of necessary requests, disaster declarations, or other documentation required as a condition of assistance

## 6. Public Information Element

The objective of the Public Information Element is to develop community awareness and understanding of the flood hazard, and to prepare for the accurate and timely provision of information during flood emergencies.

### 6.1 Community Education Task

Prepare the materials for and carry out a continuing public information program, including letters to residents in evacuation areas to increase community awareness of floods and evacuation area residents' knowledge with respect to:

- Source, nature, frequency, and potential severity of floods
- Community's system for flood recognition and dissemination of warnings to the public
- Meaning of various types of warning announcements, siren signals, and/or evacuation notices
- Areas likely to be inundated or evacuated at each level of expected flooding
- Procedures for evacuation including preparations for evacuation, routes, safe destinations, and identification of reception centers
- Actions which can be taken by property owners to reduce damages, including moving furniture and valuables, curtailing electrical power and gas service, and temporary flood proofing
- Means of requesting identification as a special warning recipient or receiving special assistance in evacuation and
- Safety and remedial actions to be taken when returning to flood-damaged buildings.

Prepare and continually provide technical information to those people employing temporary flood-proofing measures, or developing detailed subplans for warning dissemination, evacuation, and damage reduction including the:

- Identification of areas where the depth and flow of expected flooding and opportunities for egress enable the use of temporary, flood-proofing measures
- Procedures for temporary flood-proofing
- Relation between forecast flood heights and on-site depths
- Guidelines and criteria for warning dissemination and evacuation plans for hotels, motels, hospitals, and/or other facilities requiring more detailed arrangements

## 6.2 Emergency Information Task

Identify the types of emergency information to be conveyed to the public in the period prior to, during, and immediately following a flood including:

- Early watches, warnings, and evacuation notices, worded appropriately to obtain maximum public response
- Information on actions to be taken, location of safe areas and areas to be avoided, location of reception centers, and ways of obtaining emergency assistance
- Actions being taken or to be taken to deal with the flood
- Calls for labor, equipment, or other types of assistance needed for evacuation, damage reduction, and/or recovery activities
- Information concerning sources and availability of recovery assistance

Identify the means and procedures to be used in communicating each type of information with respect to:

- Form and content of each type of message
- Handling of flood warnings and other related messages
- Source and verification of messages
- Interfacing of communications equipment

Prepare warning announcements for use in various potential circumstances and expected flood heights which:

- Provide specific information and instructions
- Reference an authoritative and familiar source
- Ensure an immediate and adequate response to warning messages by the public and responsible officials by considering the various factors governing warning confirmation and warning belief

## 7. Plan Implementation Element

Planning Objective: To develop the administrative arrangements necessary for effective implementation of the flood preparedness plan.

### 7.1 Resource Identification Task

Identify type and amount of resources required for implementing the plan including:

- Technical, administrative, and other personnel
- Equipment and supplies
- Facilities.

Identify the sources of personnel, equipment, supplies, and facilities for implementing the plan including:

- Community resources
- Private resources
- Assistance through mutual aid agreements
- Federal and/or state assistance

## 7.2 Responsibility Allocation Task

Evaluate each aspect of plan implementation with respect to:

- Actions requiring detailed and specific assignments of responsibility
- Actions suitable for assignment on an organizational basis

Assign responsibility for implementation of each aspect of the plan including:

- Instructions as to how, when, and by whom implementation is to be assured
- Requirements for any necessary subplans or supplemental procedures
- Establishment of a chain of command to ensure plan implementation will proceed in the absence or incapacity of key personnel

## 7.3 Coordination Task

Establish procedures for coordination of local governmental actions through an EOC (emergency operations center), if available, or other mechanisms including:

- Identification of responsibilities to be assigned to the EOC
- Operational procedures for staffing and operation of the EOC to carry out the assigned responsibilities
- Procedures for activation and termination of the EOC

Establish necessary arrangements, including mutual aid agreements, for use of facilities, equipment, personnel, and services necessary for implementation of the plan including:

- Location of river and rainfall gages, participation of observers, and receipt of information from upstream areas
- Land rights for flood fighting and other purposes
- Use of reception centers, hospitals, and areas for property storage
- Use of vehicles for evacuation or movement of property
- Participation of volunteer organizations
- Provision of necessary supplies, materials, construction equipment, and other items

Fully coordinate the local plan with other state and local emergency operations plans. (See a list of recommended agencies for coordination in Table 2, page 5.) Establish procedures for:

- Integration with regional or statewide flood warning systems and communication networks, state flood disaster plans, and other local natural disaster plans
- Coordination of evacuation plans with those for flood control, particularly where closure of floodgates in levees or floodwalls may affect escape routes and

- Coordination with the NWS with respect to use of all available information and issuance of warnings.

Establish procedures to guide and coordinate more detailed site-specific planning for warning dissemination, evacuation, and damage reduction in public and private buildings including:

- Process for identifying locations where such plans are necessary
- Minimum elements and appropriate level of detail to be included in planning and
- Provision of technical assistance in planning.

## 8. Plan Maintenance

To update, extend, and improve the flood response plan and ensure readiness for executing the plan.

### 8.1 Plan Updating Task

Establish procedures and schedules for plan contents subject to rapid obsolescence including:

- Addresses, telephone numbers, and names of key participants
- Assignments of responsibility
- Changes in flood potential
- Areas requiring evacuation
- Availability of facilities for reception centers
- Evacuation routes and priorities
- Flood-fighting requirements
- Utility extensions or system modifications
- Traffic control requirements

Establish procedures for updating plans based on events such as the:

- Constructing, or modifying, operational, upstream, water-control structures affecting the height, severity, or time of flooding
- Natural, or unplanned, events modifying the flood potential
- Constructing, or modifying, operational facilities downstream of the community which increases the height, severity, or duration of floods

### 8.2 Plan Improvement Task

Describe needed and planned extensions of the warning system and response plan including:

- Coverage of additional area
- Incorporation of elements, tasks, and subtasks omitted from the initial plan

Describe needed and planned refinements to the warning system and response plan including:

- Provision of additional observers, gages, and flash flood alarms to improve the flood recognition system
- Detailed identification of areas to be evacuated

- Strengthening of communications involved in all aspects of the plan and
- Development of additional subplans for various affected organizations and locations.

Establish procedures for the critical evaluation of performance in real and simulated implementation of the plan including:

- Process for initiation, organization, and conduct of the evaluation and
- Process for modification of the plan based on findings of the evaluation.

### 8.3 Plan Practice Task

Establish procedures and schedules for testing those aspects of the flood warning system and response plan which are susceptible to periodic use such as:

- Procedures for communication with observer networks, the NWS, and other Federal offices, special warning recipients, organizations, and officials responsible for warning dissemination and plan execution, and others as may be appropriate
- Communications equipment including sirens, radio transmitters and receivers, flash flood alarm circuits, with particular attention to battery-powered equipment
- Auxiliary sources of electrical power and other services
- Procedures for activating the emergency operations center, sending and receiving observer reports, handling messages, preparing forecasts, disseminating warnings, placing equipment and personnel for evacuation and rescue, protecting vital facilities, and other steps in execution of the plan
- Availability and operational status of equipment for evacuation, rescue, and damage-reduction activities
- Availability and procedures to use key maps, lists, and other important plan documentation

Establish procedures and schedules for periodic simulation of those aspects of the warning system and response plan not susceptible to direct testing such as:

- Decisions to issue warnings or direct evacuation
- Evacuation
- Implementation of traffic control procedures
- Activation of reception centers
- Curtailment of utility services and
- Procedures for rescue, handling of injuries and casualties, and public health measures

**Appendix E ALERT Format**

1. Introduction

ALERT/IFLOWS gages transmit a message whenever a monitored event occurs. Messages contain two fields: an address, which indicates which sensor is reporting, and event data, which describes the event in some way. Gages can support one or more sensors whose addresses are clustered about a base address assigned to the gage when it is installed.

Selected ALERT/IFLOWS radio transmitter specifications for use on Federal Hydrologic Frequencies are:

- Modulation type: Audio frequency shift keying
- Tones: zero = 1920 Hz; one = 2133 Hz
- Speed: 300 or 1200 bits per second
- Transmitter Frequency: 169-171 MHz or 406-412 MHz bands
- Transmitter Frequency Deviation: 2.5 kHz maximum permitted
- Frequency tolerance: 2.5 parts per million

2. ALERT/IFLOWS Data Formats

Each ALERT/IFLOWS message consists of 40 bits, representing four 8-bit characters, each preceded by a single start bit and followed by a single stop bit. Bits within each byte are transmitted in order from the least to the most significant. Each site transmits its primary address and current data accumulator value at 12 hour intervals as a heartbeat message. The following table describes the transmission format, where:

A<sub>i</sub> = Address bit, where A<sub>0</sub> is the least significant bit and A<sub>12</sub> is the most significant.

D<sub>i</sub> = Data bit, where D<sub>0</sub> is the least significant bit and D<sub>10</sub> is the most significant.

Start = start bit, always 0 (space)

Stop = stop bit, always 1 (mark)

Character 1	Stop	0	1	A5	A4	A3	A2	A1	A0	Start
Character 2	Stop	0	1	A11	A10	A9	A8	A7	A6	Start
Character 3	Stop	1	1	D4	D3	D2	D1	D0	A12	Start
Character 4	Stop	1	1	D10	D9	D8	D7	D6	D5	Start

This format provides an identifier range of 0 through 8191 and a data range of 0 through 2047. The bits identified with 1 or 0 are used to confirm that an incoming message is formatted in the ALERT/IFLOWS binary code.

## Appendix F Gage Maintenance Primer

Generally, site maintenance falls into one of three categories:

- Sensor cleaning and clearing
- Sensor Alignment and Calibration
- Transmitter Alignment and Calibration

Sensor cleaning and clearing is usually needed much more frequently than calibration and alignment. Depending on the location and season, it may be necessary to visit rain gage locations as often as every few weeks to keep insects, pollen, leaves, droppings, or other debris from obstructing their catchments. Cleaning and clearing does not require as much technical skill as alignment or calibration. The AFWS system manager should determine the most cost-effective balance between frequent cleaning/clearing visits by non-technical personnel, and infrequent alignment/calibration visits by skilled personnel.

### 1. Sensor Cleaning and Clearing Problems



**Figure F- 1.** Debris in catchment

Debris from leaves, insects, and droppings are a major cause of inaccurate gage readings. To help keep debris from clogging the funnel, rain gage top sections have screens to prevent large debris and leaves from going into the funnel below. Figure F-1 shows a picture looking down into the top of a gage into the screen over the funnel. Figure F-2 shows the same view with the screen removed. Many smaller particles can be seen that have gone through the screen and are clogging the smaller funnel opening that feeds the tipping bucket.

Another common problem is low hanging branches and trees near the gage. Some sites that were installed a long time ago have become grown in, and other sites that were poorly placed to begin with may have gotten worse.

Ideally, a site should have no trees or branches anywhere near it. A good rule of thumb is to stand near a gage and estimate a 45 degree angle (hold your arms straight out, and then move them about halfway up). If you see trees “above your fingertips,” they are likely to have some effect on the gage’s reading. The bigger or closer the tree, the worse the problem is.



**Figure F- 2.** Clogged funnel

### 2. Preparing for a Visit to a Gage

If the person servicing the gage has never been to a particular site, it is best to go with someone who has been there before. Maps do not always provide enough detail to find gages, especially in heavily wooded areas. The gages are painted brown to blend in with the woods, sometimes making them hard to spot. Before visiting a gage site, personnel should call the system administrator and the National Weather Service to let them know work is planned. When cleaning gages it is likely that personnel will have to tip the tipping bucket inside



the gage. The system users and managers need to know that these tips are not being caused by rain, or by a malfunction.

### 3. Tools

The following checklist includes recommended tools for non-technical work. Figure F-3 shows some useful cleaning tools.

- Screwdrivers - An assortment of Phillips and flat blade
- Allen Wrenches – 3/32, 9/64, and 1/8 inch sizes are common
- Pliers or vise grips
- Cordless Drill – optional, but makes screw replacement go faster
- Ladder (6-8 feet) – necessary to work on gages. Use caution when climbing
- Screws – take an assortment in case you lose some, or some are missing
- “Skate” key – used to quickly remove top section from certain brand gages. Check with local coordinator or system administrator to find out whether you need this key, and where you can get it
- Pencil – used to mark the top section, and for taking notes
- Notepad – used to take notes during your visit
- Water (1-2 gallons) for cleaning and pouring into the gage as a test
- Cleaning tools including:
  - Paper shop cloths or rags
  - Teflon and brass mini-brushes
  - Bottle brush—approximately ½ inch in diameter and 12 inches long
- Brush clearing tools—clippers, hand saw, machete, bush axe, or chain saw to cut brush, trees, and branches
- Bug spray - for killing bees and wasps that sometimes nest in gages
- Scanner radio - optional but confirms site is transmitting. Set to frequency of transmitting gage.
- First aid kit



**Figure F- 3.** Cleaning tools: paper shop cloth, teflon mini-brush, bottle brush, water.

#### 4. Arriving at a Site

When you get to a gage site, follow these steps:

1. Identify yourself. If you are not sure whether the gage is on private property, and there is a house or building nearby, identify yourself and explain why you are there. It is also good to thank the landowner for his/her civic-mindedness in allowing the use of their property. If trees or bushes need to be trimmed, ask the landowner for permission.
2. Look for obvious problems. Are brush, trees, and shrubs making it hard to get close to the gage? If so, cut down the brush. In level, cleared areas away from home sites, a quick solution is to run grass over a few times with the vehicle, taking care there are no large rocks hidden that could do damage to the underbody.
  - a) Are there overhanging trees or limbs? You should have clear line of sight to most of the sky. If possible, trim trees and branches that are in the way.
  - b) Do you see all the major gage parts? Make sure the antenna and solar panel are there, and that no one has vandalized the gage by shooting or driving into it.
  - c) Is the gage noticeably leaning or damaged? Gages should be standing vertically, undamaged by shot holes or dents, and steady in the ground. If the gage leans or moves easily, contact the system administrator.
3. Decide whether to continue. If you see something wrong with the gage, write down the problem and end your visit. If parts of the gage are damaged or missing, a repair is needed before cleaning. Tell the county contact point or system administrator about the problem you discovered.

## 5. Taking Apart the Gage

To clean a gage, you will have to remove the top section. In most types of gages, the top section holds the funnel, and is above a shorter tipping bucket section, as shown in Figure F-4. In a few gages, they are combined as one piece. The directions are similar for either type. You will need a ladder, and a screwdriver, Allen wrenches, or a special access key for certain brands of gages.



**Figure F- 4.** Tipping buckets and top sections for two gage brands.

Follow these steps to disassemble the top section:

1. Check for bees. Before starting to take off the top section, make sure there are no bee or wasp nests inside. Usually you will notice activity near the top section, or through the drain holes about two feet down from the top. If there are no obvious signs, tap the top section of the gage to make sure. A common location for a nest is underneath the funnel. If you notice activity, spray insect killer into the gage and wait for the spray to take effect.
2. Remove the screws holding the top section in place. The screws holding the top section in place are near the bottom of the section. Some gages also have screws at the very top that hold the funnel in place. Always use caution when climbing ladders.
3. Mark the top section. Before you remove the top section, make a pencil mark that will help you line up the sections that you are separating. It will make it easier to reassemble. Also, if the solar panel is mounted on the top section, mark which way it is pointing so that it can be put back correctly.
4. Remove the top section by lifting upward and rocking it slightly. Then, carry the top section down the ladder, or pass it to your helper on the ground. For most brands of gages, the top section contains only the funnel. If you are comfortable with working on a ladder, you can clean the tipping bucket in place, as in Figure F-5. If you have a top section different from those shown in Figure F-4, or if you prefer to work on the ground, there should be enough slack in the tipping bucket cable for it to reach the ground.



**Figure F- 5.** Working on a gage.

6. Cleaning the Tipping Bucket

Figure F-6 and Figure F-7 show pictures of a tipping bucket and how it works. The tipping bucket is built like a seesaw with two buckets that catch water from above. When the first side fills up, the weight of the water makes the seesaw tip. The water in the first bucket dumps out and the second bucket moves into place to catch more water. When the bucket tips, a magnet on the side of the bucket passes another magnet on the stationary part of the tipping bucket assembly, making an electronic pulse. A wire carries this pulse to the transmitter. Each tip of the bucket measures 1 millimeter, equal to four-hundredths of an inch of rain.



Figure F- 6. Tipping bucket.

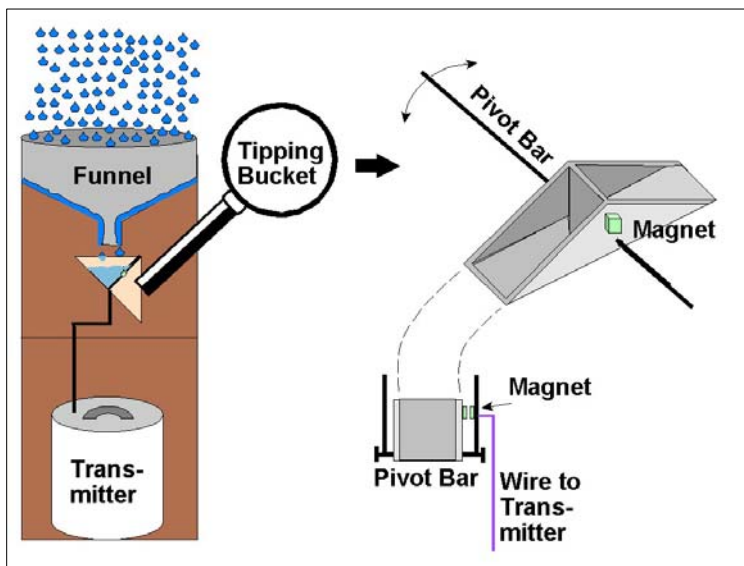

Figure F- 7. Tipping bucket operation.

While you have the tipping bucket apart, look for signs of obvious damage, like cracks or leaks. Some tipping buckets may distort in shape from freezing water. If you see anything you think is a problem, write it down in your notebook, and let the system administrator know. Figure F-8 and Figure F-9 show examples of debris that accumulates in tipping buckets. Use the cleaning brushes to remove stuck on dirt and debris that has accumulated in the buckets and in the funnel. Wipe all parts thoroughly with a shop cloth or rags, then pour some water through the funnel and bucket opening to rinse it out. Remember that each

time you tip the bucket it transmits a message that shows up as rain, so try to keep the number of tips to a minimum. When you are finished cleaning, the parts should look like Figure F-10 and Figure F-11. Figure F-12 and Figure F-13 are photos of a clean funnel and clean screen, looking down from the top.



**Figure F- 8.** Clogged tipping bucket, top view.



**Figure F- 9.** Dirty tipping bucket, side view.



**Figure F- 10.** Clean tipping bucket, top view.



**Figure F- 11.** Clean tipping bucket, side view.



**Figure F- 12.** Clean funnel, top view.

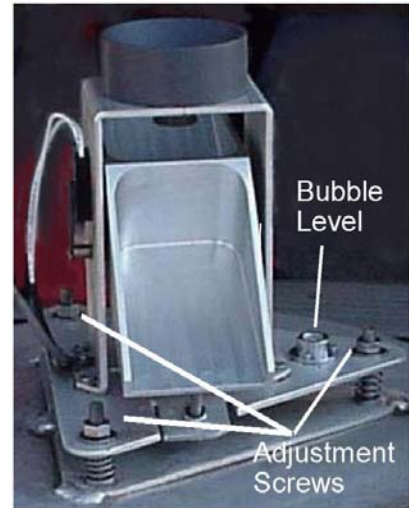

**Figure F- 13.** Clean screen, top view.

## 7. Leveling the Tipping Bucket

After you have cleaned the parts mentioned above, the tipping bucket must be leveled. Leveling is very important for rainfall reporting accuracy. The tipping bucket is carefully designed to hold four-hundredths of an inch of rain for each tip. If the tipping bucket is not level, the amount of rain in each tip is wrong, and will show up as an error in measurement. Large errors can be noticed, but the smaller errors can fool forecasters into thinking a gage is reporting accurately when it is not. To level the tipping bucket:

1. Mount the base of the tipping bucket back onto the standpipe. Check your pencil marks to line it up the same way as when you started.
2. Set the tipping bucket on the base. Make sure it is turned so that the bucket won't hit the vent tube or cables when it tips. Also turn it so that it is not in direct line to the four weep holes in the side of the top section. This is to prevent the wind from blowing into the hole and tipping the bucket.
3. Check the bubble level on the base of the tipping bucket shown in Figure F-14. Turn the adjustment screws so that the bubble is centered in the glass window.



**Figure F- 14.** Tipping bucket level adjustments.

## 8. Final Steps

Before putting the funnel and screen back in place, do the following:

1. Wipe the solar panel clean with water and a shop cloth.
2. Turn on your scanner and listen to the transmit frequency of the gage. Tip the bucket and listen for a short “chirp” from the transmitter. The chirp may take up to 20 seconds after a tip, especially if you are only allowing a second or two between tips. If you do not eventually hear a chirp when you tip the bucket, something is wrong with the transmitter. Report this to the system administrator.
3. Reinstall the funnel and screen, replacing the screws you took out.
4. Pour water into the top of the gage, slowly and steadily, to confirm the gage is still chirping.
5. Before leaving, write the date and time you visited the site, what you did, and any observations you have that will help maintain the gage.
6. Report to the system administrator when you return, either by web board, email, or telephone call.

## 9. Electronic Component Servicing

Additional servicing that is normally done by qualified service personnel includes the following:

- Battery
  1. Check voltage both before and during transmission
  2. Check terminals for corrosion and loose terminals/connections

3. Follow battery manufacturer's instructions for discharging battery prior to recharging. Note: A solar panel charging system is highly recommended as part of the field installation.
- Antenna
    1. Position antenna elements so that they are not directly above the rain gage's collector.
    2. Check reflective power in and out
    3. Conduct visual inspection for missing elements or other damage. Look for broken or exposed antenna cable.
    4. Check antenna clamps to assure bolts are tight.
    5. Verify antenna direction for directional type antennas
    6. Plug top of antenna mast, if necessary, to keep water out of standpipe.
  - Tipping bucket
    1. Conduct static and dynamic calibration tests at least once every two years
  - Water Level Sensor (Shaft Encoder)
    1. Check reed switches when unit will not hold calibration.
    2. Rotate wheel several turns to make sure chain doesn't jump off sprocket, at every visit.
    3. Check wires at terminal block and plug with ohmmeter, at every visit.
  - Calibrate to ensure accuracy, at every visit.
    1. Water Level Sensor (Pressure Transducer)
    2. Check for vandalism and for biological fouling, silting, sand, wood, plastic, etc, at every visit.
    3. Check to make sure straps are holding, at every visit. Replace straps or add more if movement is noticed.
    4. Check pressure transducer plug at transmitter for loose or broken wires, at every visit.
    5. Reseal any electronic components in a liquid epoxy, when necessary.
  - Transmitter
    1. Disconnect, clean, and reconnect the connections between main board, back board, and plug-in sockets to ensure positive electrical contact, once per year.
    2. Measure output in watts, at every visit.
    3. Replace desiccant pack, once per year.
    4. Check frequency and modulation yearly.
  - Standpipes
    1. Re-level pipes if required.
    2. Seal any gunshot holes.

- Base Station (Computer/Software/Radios)
  1. Check station, daily
  2. Switch to standby power on a regular schedule to ensure proper operation
  
- Repeater
  1. Check battery and connections, at every visit
  2. Check antennas for damage, at every visit.
  3. Check coaxial transmission line and connectors to antennae for damage, at every visit.
  4. Check commercial power and/or solar panel and connecting cables, at every visit.
  5. Check frequency and modulation yearly



**Appendix G Selected References**

Hydrology Subcommittee of the Federal Interagency Advisory Committee on Water Data. August 1985. Guidelines on Community Local Flood Warning and Response Systems.

National Weather Service, Office of Hydrology. August 1993. Integrated Flood Observing and Warning System Management Guide. Department of Commerce, NOAA, Silver Spring, Maryland.

National Weather Service, Eastern Region. 1988. Unpublished Technical Memorandum on ALERT Systems. Department of Commerce, NOAA, Northeast River Forecast Center, Taunton, Massachusetts.

National Weather Service, Western Region. October 1982. Automated Local Evaluation in Real Time—A Cooperative Flood Warning System for Your Community. Department of Commerce, NOAA, Silver Spring, Maryland.

Owen, H. James. 1977. Guide for Flood and Flash Flood Preparedness Planning. Prepared for Department of Commerce, NOAA, National Weather Service, Silver Spring, Maryland.

Owen, H. James. 1979. Information for Local Officials on Flood Warning Systems. Prepared for Department of Commerce, NOAA, National Weather Service, Silver Spring, Maryland.

U.S. Bureau of Reclamation. 1995. Emergency Planning and Exercise Guidelines. Department of the Interior, Denver, Colorado.