

Department Of Veterans Affairs
Decentralized Hospital Computer Program

LABORATORY TECHNICAL MANUAL

Version 5.2

October 1994

Information System Center
Dallas, Texas

Preface

The Laboratory Technical Manual has been designed to provide the Department of Veterans Affairs Medical Center (VAMC), Information Resources Management Service (IRM), and the Laboratory Information Manager (LIM) with the necessary technical information required to efficiently and effectively implement, maintain, and manage Laboratory Version 5.2 software package.

The technical documentation provides sufficient information about the software package for programmers and IRM technical personnel to operate and maintain the software package without additional assistance from package Developers. This Technical Manual was created to fulfill that requirement.

Table of Contents

Introduction.....	1
Purpose.....	3
Area of Application	3
Organization of Manual.....	3
Functional Description	4
Functionality	5
Laboratory Module Work Flow.....	7
Package Specific Notations.....	8
Implementation and Maintenance.....	9
System Integrity Checks.....	11
Check Files for Inconsistencies [LRCHKFILES].....	11
Check Patient and Lab Data Cross Pointers [LRCKPTR].....	13
Laboratory Package Routine Integrity Menu	14
Lab Routine Integrity Menu.....	14
[LR Integrity Loop]	15
[LR Integrity Load].....	15
[LR Integrity Single]	15
File Editing.....	16
Other Laboratory Configurable Files	17
Laboratory Files Not to be Edited.....	18
New Data Names.....	19
Add a New Data Name Using a Option	19
Add a New Data Name Using VA FileMan	20
File Structure/Interaction	21
Editing the Files.....	23
General Laboratory.....	24
Menu Description	24
Laboratory Security Keys.....	25
Workload Recording.....	26
Lab Labels.....	28
Microfiche of Path Reports	30
Cumulative Report.....	31
Further Cumulative Functionality (Version 5.2).....	32
TaskManager.....	37
Device Parameters.....	38
Initialize LAC Globals & X References [LRAC INITIALIZE]	38
Interim Reports.....	39
Tasking the Interim.....	41
Batched Interim	41
Instrumentation and Interfacing.....	43
Supervisors/Choosers of Instrumentation.....	45
Load/Work Lists	46
Instrument Data Flow.....	47
Automated Instrument Interfacing.....	49

Table of Contents

Automated Instrument Data Flow.....	50
AUTO INSTRUMENT file (#62.4) Fields List.....	51
AUTO INSTRUMENT file (#62.4) Fields Description.....	53
Bidirectional Communications.....	60
Handshake Routines (Bi-directional)	61
Processing Routine.....	62
Download Routine.....	63
Bidirectional Related Fields	63
Version 2 LSI Eprom Installation.....	65
LSI Wire Wrapping.....	71
Other LSI Chip Information.....	74
Wiring Diagrams and Pin Definitions for Automated Instruments.....	75
Automated Instrument Interface Specifications.....	75
Automated Instruments Interface	77
Interfacing Pin Definitions.....	78
LSI Interface Testing	78
Checklist for Instrument Interface	78
Instrument Interface Troubleshooting	79
LAPORTX X Routine.....	84
LAPX Routine	84
Instrument Routines.....	85
^LA & ^LAH Global Descriptions	90
Justification and Descriptions	90
Description of ^LA Global.....	90
Description of ^LAH Global.....	90
VAX Example of Device Setup	91
Example of How to Define the Echo Device.....	93
Bar Code Readers (Blood Bank Module).....	94
Bar Code Labels	95
Implementation for the OTC 800 Printer.....	96
Implementation for Intermec 8646 Printer	98
MicroScan Interface.....	100
Implementation.....	100
MicroScan Mainframe Interface Version 19.02 Software.....	102
The Upload.....	110
The Download	112
VITEK Interface.....	114
VITEK Interface Instructions.....	114
Troubleshooting for VITEK	133
Printout A	136
Printout B	137
Printout C	139
Printout D	140
Printout E	142
Interface Guide for OE/RR Package.....	145
Routine Descriptions.....	149
OE/RR Routines	170

Callable Routines	171
Supported References.....	173
Entry Point References.....	174
File List and Descriptions	177
File List	179
Brief File Descriptions.....	181
Exported Options.....	187
Laboratory Options List.....	189
Distribution of Menus.....	200
Menus with Entry or Exit Action.....	200
Security Keys.....	201
Individual Module Requirements/Concerns	202
Anatomic Pathology	202
Blood Bank.....	202
Chemistry/Immunology	203
Microbiology	203
Phlebotomy.....	203
LRTASK Options.....	204
Cross References	207
Purging and Archiving	219
Force Cumulative Data to Permanent Page [LRAC FORCE]	221
Purge Old Orders and Accessions [LROC]	223
Archive of LAB DATA file (#63)	224
Archive Options.....	224
Search for Lab Data to Archive.....	225
Write Data to Off-Line Media	225
Clear data from the LAR global	225
Read Data from Off-Line Media	225
Purge Data Found in the Search Option.....	225
Find Patient's Archived Data.....	225
Convert Archived LR Data.....	226
Restore Archived Data to LR Global	226
External Relations.....	227
External Referenced Files and Fields.....	229
External Routines.....	230
External Variables.....	230
Required Software	230
DBA Integration Agreements	231
Laboratory as a Subscriber.....	233
Internal Relations.....	253
Stand Alone Menus.....	255
Package-wide Variables.....	257

Table of Contents

Committee (SACC) Exemptions	261
On-line Documentation.....	265
File Number Ranges	267
Namespacing	267
Special Templates.....	267
On-Line Help Using Kernel.....	267
On-line Help From Your Terminal Screen	268
How To Print Data Dictionaries.....	269
Global Journaling.....	271
Mapping Routines.....	275
Glossary.....	279
Appendix A.....	305
Index	315

INTRODUCTION

Introduction

Introduction

Purpose

The purpose of the Laboratory Technical Manual is to provide the Department of Veterans Affairs Medical Center (VAMC), Information Resource Management Service (IRM), and Laboratory Information Manager (LIM) with a technical description of the Lab package setup, special capabilities, files, security, routines, globals, and data dictionaries. Familiarity with the fundamentals of MUMPS, VA FileManager, Laboratory User Manual, Blood Bank User Manual, Anatomic Pathology User Manual, and the Planning and Implementation Guide is assumed.

Area of Application

The Laboratory V. 5.2 package covers every functional area of the Clinical Laboratory:

- Anatomic Pathology
- Blood Bank
- Chemistry
- Coagulation
- Hematology
- Microbiology
- Phlebotomy
- Quality Control
- Results Reporting
- Serology
- Surgical Pathology
- Test Accessioning/Ordering
- Toxicology
- Urinalysis
- Auto Instrument
- Workload Recording

Organization of Manual

This manual is organized into major chapters plus an Introduction and a Glossary for the complete guide. The chapters represent functional content areas or issues to be addressed in package implementation and maintenance.

Other manuals relevant to the Laboratory package are:

- Anatomic Pathology User Manual
- Blood Bank User Manual
- Laboratory User Manual
- Laboratory Technical Manual
- Laboratory Planning and Implementation Guide
- VA FileManager User Manual
- VA FileManager Programmer Manual
- Users Guide To Computing
- MailMan User Manual
- Kernel Systems Manual
- Kernel Technical Manual

Functional Description

- What is the Laboratory Package?

The Laboratory package is part of the integrated Decentralized Hospital Computer Program (DHCP) Core Package and a clinically oriented system designed to provide data to health care providers as well as to other health care personnel. Its primary function is to assist the Pathology & Laboratory Medicine Service in managing and automating the workload and reporting process. The Laboratory package includes software for all major functional areas; selected examples of software modules are illustrated in this section.

- Who does the Laboratory package serve?

Health Care Providers/Other Health Care Providers:

The Laboratory package is a clinically oriented application, designed to provide data to health care providers as well as to other health care personnel. For this reason, it is a multifaceted package with many spin off advantages for other hospital services. Its primary function is to assist the Pathology & Laboratory Medicine Service in managing and automating workload generated by the Medical Center primary mission.

- Who can use the Laboratory Package and for what purpose?

The Health Care Provider:

The Laboratory package provides a method for Health Care Providers to place requests into the system for collection and analysis of patient's specimens. It also provides a means of tracking work activities to completion and reporting. When results become available, users may view the results in a variety of formats.

The Clinical Pathology & Laboratory Medicine Service:

The package provides methods of identifying and processing workload.

Test result values are accepted from manual input and/or automated instruments and test data is displayed for review before verification.

After verification, the results may be automatically distributed to appropriate locations throughout the institution.

Data is provided for management reports and administrative support.

- What are the benefits of the Laboratory Package?

Lab test information is more accurate, timely, and accessible.

Status of orders is more accessible to lab and hospital personnel.

Abnormal and critical values can be flagged to assist in verification and review of data.

Quality control data can be collected, automatically performed, and reported.

Delta checks can be made on a series of data to establish trends or significant clinical variations in value.

Functionality

- **Phlebotomy/Ordering**

Supports ward order entry.

Reports status and transactions of tests.

Prints collection lists/labels.

Tracks the laboratory accession numbers and order numbers.

Provides maximum ordering frequency (number per day, daily, user defined limits).

Flag duplicate orders.

Processes special ward instructions at time of ordering.

- **Specimen Processing**

Provides worklists by urgency and accession number (instrument-specific).

Produces incomplete lists.

Produces workload/data capture reports.

Produces review lists for verification of data.

- **Verification/Release of Data**

Provides Delta Checks, flagging high/low/critical results.

Provides customized input checking.

Provides automatic calculations (e.g., LDL).

Supports review/verification by group or individuals accessions.

Unidirectional and Bi-directional Auto Instrument Support.

- **Reports**

Produces supervisory management reports, audit trail reports, system integrity reports, quality assurance, and utilization review reports.

Produces discharge summaries and cumulative and discrete episode reports.

Produces automatic transmission of data at time of verification to the ordering location.

Provides quality control.

Provides search capabilities (SNOMED criticals, HI-LO).

Provides Antimicrobial Trend Reports.

Provides Infection Control Reports.

Provides Health Department Reports.

Provides multiple reports of microbial interpretation.

Provides searches for cytological agents with defined antimicrobial patterns.

Laboratory Module Work Flow

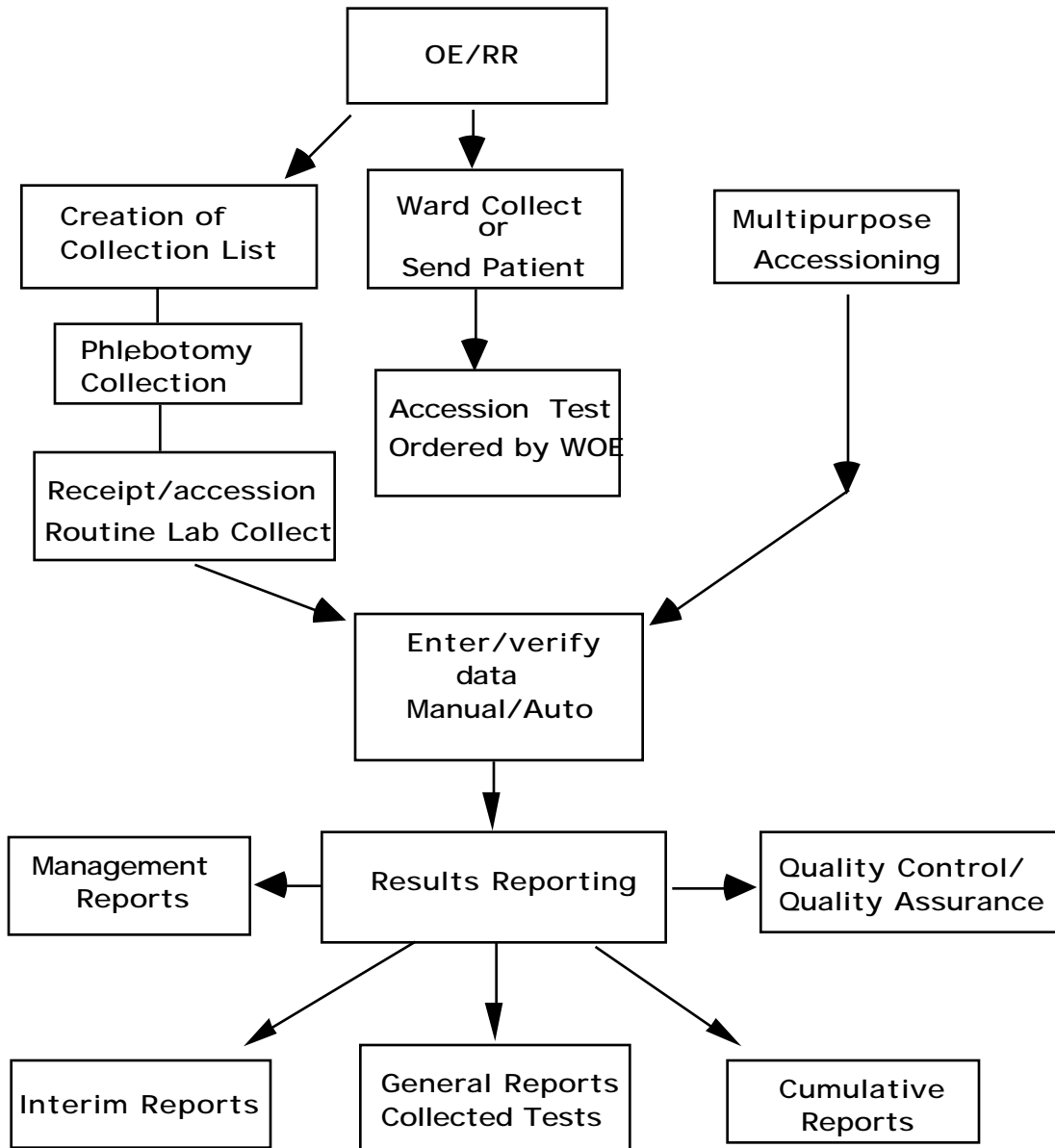

Package Specific Notations

This section describes notes and warnings used to indicate user responses.

Warning Symbol

⚠ **WARNING:** The warning symbol indicates that the action to be performed is critical.

Note Box

NOTE: The note box indicates that a special action may be recommended or required.

IMPLEMENTATION AND MAINTENANCE

System Integrity Checks

Check Files for Inconsistencies [LRCHKFILES]

This option includes the check from Check Patient and Lab data Cross Pointers [LRCKPTR] option plus additional checks on potential inconsistencies in various files. The following is a list of some of the messages which might be generated if there are discrepancies or problems. There are several routines that run when this option is called up. This option is most useful when you are initially setting up your files.

NOTE: Only the first 20 errors are totaled for the section, but a total error count is provided with the group.

Messages: Messages are labeled either: **F** (fatal) or **W** (warning).

NOTES:

- Messages are labeled either **F** (fatal) or **W** (warning).
- Fatal indicates potential problems with various software functions. Consult your Regional ISC if necessary.
- Warning is not critical, and under most situations can be ignored. However, if you are experiencing problems with a particular item, please investigate. Consult your respective ISC if uncertain of the impact.

From File #60: The user can choose not to check tests that are defined as NEITHER in the TYPE field when the option is selected.

- F - A test can NOT be Atomic and Cosmic at the same time.
- W - Atomic test has no site/specimen; therefore no units or range
- F - Test MUST have a HIGHEST URGENCY value
- F - The data name field must be re-entered to set up location and field
- F - BAD Data name
- F - Needs a print name entered
- W - Does not have a print order
- F - BAD pointer to the ACCESSION file (#68)
- F - BAD lab collection sample pointer to the COLLECTION SAMPLE file (#62)
- F - BAD pointer to the PROCEDURE file (#61.5)
- F - BAD Edit code pointer to the EXECUTE CODE file (#62.07)
- F - BAD Batch data code pointer to the EXECUTE CODE file (#62.07)
- F - BAD pointer in panel
- F - Test is on its own panel (infinite loop)
- F - BAD entry in Specimen/Site subfile
- F - BAD Specimen/Site subfile pointer to TOPOGRAPHY FIELD file (#61)
- F - BAD type of DELTA CHECKS file (#62.1) pointer
- F - BAD collection sample pointer to COLLECTION SAMPLE file (#62)
- F - BAD required comment pointer to EXECUTE CODE file (#62.07)

From File #68:

- F - Missing the LR subscript
- W - Missing the print order
- F - Has no abbreviation
- F - BAD common accession # pointer to the ACCESSION file (#68)
- F - BAD accession transform pointer to the EXECUTE CODE file (#62.07)
- F - Accession transform field and EXECUTE CODE file (#62.07) not match
- F - BAD verification code pointer to the EXECUTE CODE file (#62.07)
- F - Verification code and EXECUTE CODE file (#62.07) don't match
- F - Does not have an accession
- W - Does not have an order number
- F - Does not have an Order on file
- F - BAD pointer to test LABORATORY TEST file (#60)
- F - BAD pointer to URGENCY file (#62.05)
- F - BAD pointer to the specimen COLLECTION SAMPLE file (#62)
- F - BAD pointer to COLLECTION SAMPLE file (#62)
- F - BAD instrument pointer to the AUTO INSTRUMENT file (#62.4)
- F - BAD control name pointer to the LAB CONTROL NAME file (#62.3)

From File #69:

- F - Entry LRDFN in ^LR(is missing
- F - Does not have an ORDER number
- F - BAD pointer to COLLECTION SAMPLE file (#62)
- F - BAD pointer to the USER file (#)
- F - BAD pointer to the LABORATORY TEST file (#60)
- F - BAD pointer to the URGENCY file (#62.05)
- F - BAD pointer to the ACCESSION file (#68)
- F - BAD pointer to the specimen TOPOGRAPHY file (#61)

From File #s 68.2 and 62.4

- F - MISSING ZERO NODE
- F - Has duplicate routine entry
- F - SYSTEM must have a device to get the data from
- F - Has no program name. This will prevent data processing
- F - Must have a Load/Work List entry
- F - Enter a number that has a BAD test pointer
- W - A sequence/batch should have 0 cups/tray
- F - BAD pointer in the LOAD transform field
- F - BAD pointer in the INITIAL setup field
- F - Does not have a profile defined
- F - Has a BAD test pointer
- F - At least one test of the panel must NOT be build name only
- F - BAD accession area pointer

All of the **F** or **W** messages give you a place to start looking within each file mentioned; most of them you can fix by making required field changes. Some will have to be fixed by using some of the utility functions of VA FileMan or re-cross-referencing certain fields within files. If the “fix” is not evident to you, ask your ISC for help.

You should run this check every three months and after any unscheduled downtimes.

Check Patient and Lab Data Cross Pointers [LRCKPTR]

This option should probably be run on some kind of routine basis (monthly would probably be more than adequate). This could be part of a laboratory quality assurance program to verify the internal consistency of the laboratory data files. The program goes through each file to see if there is an LR pointer. If there is, it then looks to see if that pointer is correct. The program then goes through the lab data file to see what file is being pointed to and makes sure there is a corresponding entry in that file.

Laboratory Package Routine Integrity Menu

Lab Routine Integrity Menu

This menu option is designed for IRM Site Managers to provide the means to load LR ROUTINE INTEGRITY CHECKER file (#69.91) with data after package installation and provide a method to view data on a single routine. It loops through the File #69.91 to determine if any routines have been changed/edited. Lab Routine Integrity [LR INTEGRITY] menu is composed of three options:

- 1) LR Integrity Load
- 2) LR Integrity Loop
- 3) LR Integrity Single

This menu is also designed for support persons to determine the integrity of the laboratory routines, by determining the routine size and the ASCII value of the characters which are in the routine. By using these values you can determine:

- If the routine has been altered or edited.
- The size of the routine (used in determining routine map space.)
- A double-check on patch application. (This is not foolproof.)
- The total number of routines (excluding all INITs).
- Options which have been deleted or renamed. These are used in the post INITs.

NOTES:

- LR ROUTINE INTEGRITY CHECKER file (#69.91) is based upon versions. If a version is no longer in use, that version can be deleted from the file.
- The Lab Routine Integrity [LR INTEGRITY] menu is distributed on the Lab liaison [LRLIAISON] menu.
- You must delete all INITs before loading these routines.

This file is not exported with routines. The site must load the routines into the global/file. Option LR Integrity Load is provided for that purpose.

Loop thru LR Integrity [LR Integrity Loop]

This option will loop through the entire LR ROUTINE INTEGRITY CHECKER file (#69.91) to determine if any of the loaded routines in the file have been changed or edited.

Load Integrity File [LR Integrity Load]

This option will load the LR ROUTINE INTEGRITY CHECKER file (#69.91) with lab routines which have the correct version number in the second line. Those routines which do not match (e.g., LRINITs) will not be loaded.

The option should be done as soon as possible. Users can be logged on during this process.

If there are local routines in the LRZ namespace and you wish these to be included in the LR ROUTINE INTEGRITY CHECKER file (#69.91), they must have the correct second line format and version number.

Second line format

```
;;xx.xx;LAB SERVICE;**pn**;date/time
```

where xx.xx=Version Number

pn=Patch Number

Check a Single Routine Size [LR Integrity Single]

This option allows you to review stored data about a single routine. After entering the routine name, the option will show you the current data and compare this data with values stored in LR ROUTINE INTEGRITY CHECKER file (#69.91). It then indicates if the routine has been changed/edited.

This option will also allow you to determine if a patch has been applied correctly. To get a complete listing, use the VA FileMan Print option.

File Editing

Editing file entries can be performed by the Laboratory Information Manager if they have VA FileMan access. File attributes **generally** can not be edited.

There are certain files and or fields which require great caution when editing or entering data. Some of these fields may contain mumps codes. A FileMan access code of programmer is required to edit these files/fields. The assignment of programmer access codes is a local issue. Therefore, certain files and fields may not be accessible by the LIM.

NOTE: Deletion from most files is strongly discouraged. It can be done in certain instances, but use caution. If there is any uncertainty, do not delete entries until advised by your Regional ISC.

If file entries are edited (either initially or after system implementation), they **must** be done in this order:

1. TOPOGRAPHY FIELD file (#61)
2. COLLECTION SAMPLE file (#62)
3. ACCESSION file (#68)
4. LAB DATA file (#63)
5. LABORATORY TEST file (#60)
6. ACCESSION TEST GROUP file (#62.6)
7. LABORATORY SITE file (#69.9)

It is recommended that before adding entries to the above files, you run Check Files for Inconsistencies [LRCHKFILES] option to find any inconsistencies. Correct any **fatal** responses listed. When this is completed, you will be ready to add new entries.

After the above files are finished, other files may be changed in any order. The above seven files must be changed in that order because of the interdependence of the files.

Other Laboratory Configurable Files

- MORPHOLOGY FIELD file (#61.1)
- ETIOLOGY FIELD file (#61.2)
- FUNCTION FIELD file (#61.3)
- DISEASE FIELD file (#61.4)
- PROCEDURE FIELD file (#61.5)
- OCCUPATION FIELD file (#61.6)
- URGENCY file (#62.05)
- ANTIMICROBIAL SUSCEPTIBILITY file (#62.06)
- EXECUTE CODE file (#62.07)
- DELTA CHECKS file (#62.1)
- LAB SECTION file (#62.2)
- LAB CONTROL NAME file (#62.3)
- AUTO INSTRUMENT file (#62.4)
- LAB DESCRIPTIONS file (#62.5)
- AGGLUTINATION STRENGTH file (#62.55)
- WKLD CODE file (#64)
- WKLD LOG file (#64.03)
- WKLD NON WORKLOAD PROCEDURES file (#64.05)
- WKLD CODE LAB SECT file (#64.21)
- LAB REPORTS file (#64.5)
- INTERIM REPORTS file (#64.6)
- BLOOD INVENTORY file (#65)
- BLOOD BANK UTILITY file (#65.4)

Implementation and Maintenance

- BLOOD DONOR file (#65.5)
- LAB LETTER file (#65.9)
- BLOOD PRODUCTS file (#66)
- OPERATION (MSBOS) file (#66.5)
- BLOOD COMPONENT file (#66.9)
- REFERRAL PATIENT file (#67)
- RESEARCH file (#67.1)
- STERILIZER file (#67.2)
- ENVIRONMENTAL file (#67.3)
- LOAD/WORK LIST file (#68.2)
- WORKLIST HEADINGS file (#68.4)
- LAB JOURNAL file (#95)

Laboratory Files Not to be Edited

- ARCHIVED LR DATA file (#63.9999)
- WKLD SUFFIX CODE file (#64.2)
- ARCHIVED WORKLOAD DATA file (#64.19999)
- WKLD ITEM FOR COUNT file (#64.22)
- WKLD INSTRUMENT MANUFACTURER file (#64.3)
- CUMULATIVE file (#64.7)
- ARCHIVED BLOOD INVENTORY file (#65.9999)
- NON PATIENT WORKLOAD file (#67.4)
- LAB MONTHLY WORKLOADS file (#67.9)
- ARCHIVED LAB MONTHLY WORKLOADS file (#67.99999)
- LAB ORDER ENTRY file (#69)

New Data Names

In the LABORATORY TEST file (#60), each test entry with a CH subscript and a type of BOTH or OUTPUT has a location or data name. See the location Data Name field of File #60. This data name points to a unique field in the LAB DATA file (#63) where the data for that test is to be stored. This unique field also defines what type of value can be entered as a result for the test (free text, numeric, or a set of codes).

NOTE: Panels, profiles, and tests with subscripts other than CH do not have data name entries.

The exported version of the LAB DATA file (#63), subfield #4 contains subfield entries called data names, most of which are associated with corresponding pre-supplied entries in the LABORATORY TEST file (#60). These data names determine the type of response allowable when entering a result for a laboratory test. You should print a list of possible subfields to determine if additional entries must be added. The addition of data names must be done by using Add a new data name [LRWU5] option.

Add a New Data Name Using a Option

Select Lab liaison menu Option: **DATA** Add a new data name

This option will add a new data name to the lab package.

DATA NAME: **GLUCOSE-TIMED**

ARE YOU ADDING GLUCOSE-TIMED (SUBFIELD # 7022001) AS A NEW DATA NAME? NO// **Y**
(YES)

Enter data type for test: (N)umeric, (S)et of Codes, or (F)ree text? **F**

Minimum length: **2**

Maximum length: **30**

'GLUCOSE-TIMED' added as a new data name

Data Name: GLUCOSE-TIMED Subfield #: 7022001 Type: FREE TEXT

Input Transform: K:\$L(X)>30!(\$L(X)<2) X

Minimum length: 2

Maximum length: 30

You must now add a new test in the LABORATORY TEST file and use GLUCOSE-TIMED as the entry for the DATA NAME field.

Add a New Data Name Using VA FileMan

```
Select VA FileMan Option:  4  Modify File Attributes
MODIFY WHAT FILE: //  63  LAB DATA
Select FIELD:  4  CHEM, HEM, TOX, RIA, SER, etc. (Multiple
LABEL:  CHEM, HEM, TOX, RIA, SER, etc.  Replace <RET>
READ ACCESS (OPTIONAL) <RET>
WRITE ACCESS (OPTIONAL):<RET>
SOURCE: <RET>

Select DESTINATION: <RET>
Select GROUP: <RET>

Select CHEM, HEM, TOX, RIA, SER, etc.  SUB-FIELD: 555001
  (enter the sub-field number = station # + entry # in the format of
  "555001", "555002", "555003", etc.)
ARE YOU ADDING A NEW CHEM, HEM, TOX, RIA, SER, etc. SUB-FIELD NUMBER (THE
800TH)? Y//<RET>(YES)

LABEL:  SERUM MAYONNAISE
  CHEM, HEM, TOX, RIA, SER, etc. SUB-FIELD NUMBER:  555001// <RET>

DATA TYPE OF SERUM MAYONNAISE:  FREE TEXT
MINIMUM LENGTH:  1
MAXIMUM LENGTH:  10
(OPTIONAL) PATTERN MATCH (IN 'X'): <RET>
WILL SERUM MAYONNAISE FIELD BE MULTIPLE ?  NO// <RET>
SUBSCRIPT:  49// 555001  (**NOTE: this must always match the sub-field
number!!!)
-POSITION:  1// <RET>  (**NOTE:  this answer must always be '1')
IS SERUM MAYONNAISE ENTRY MANDATORY  (Y/N):  NO// <RET> (NO)
'HELP' - PROMPT: ANSWER MUST BE !-!) CHARACTERS IN LENGTH  Replace
EXECUTABLE 'HELP':  <RET>

Select CHEM, HEM, TOX, RIA, SER, etc.  SUB-FIELD:  ^
```

You now have a new data name for the test SERUM MAYONNAISE. When you enter SERUM MAYONNAISE as a new test in the LABORATORY TEST file (#60), be sure to fill in the Data Name field with the number **555001**. The test name will then point to the correct new data name.

File Structure/Interaction

Before you begin the process of reviewing and editing the Laboratory package files (also known as site-configuring), it is important to note which of the files should be edited prior to implementation and the sequence in which they should be modified.

The database for the Laboratory package is composed of a series of files. These files contain all the information that is needed by the system to process or interpret test data and are the basis for storage, organization, and retrieval of that data.

The files and the data they contain form the backbone of a comprehensive network that is used on three levels:

- 1) within files
- 2) between files in the lab package
- 3) among files in the lab package and other package files.

Information within a file may in some ways be dependent upon other elements stored in the **same file**. When this occurs, it is said that the file points to, or references itself. Similarly, data contained in one file may point to another separate file or a group of files. Finally, files within the lab package can be pointers to files found in other packages in the system (i.e., ADT or PHARMACY). This occurs when the lab file information is drawn **from** data contained in an outside file or when the lab file information **points to** an outside file.

Based on the relationships which exist between the files, the sequence of events during file modification becomes very important. Files which must be edited or modified in sequence are:

1. TOPOGRAPHY file (#61)
2. COLLECTION SAMPLE file (#62)
3. ACCESSION file (#68)
4. LAB DATA file (#63)
5. LABORATORY TEST file (#60)
6. ACCESSION TEST GROUP file (#62.6)
7. LABORATORY SITE file (#69.9)

These seven files are also known as Day One files, although editing of other files in addition to those listed above must be done in order to bring up a fully functional Laboratory package.

We are classifying them as primary or preimplementation files, which include the following:

1. TOPOGRAPHY file (#61)
2. COLLECTION SAMPLE file (#62)
3. ACCESSION file (#68)
4. LAB DATA file (#63)
5. LABORATORY TEST file (#60)
6. ACCESSION TEST GROUP file (#62.6)
7. LABORATORY SITE file (#69.9)
8. LAB CONTROL NAME file (#62.3)
9. AUTO INSTRUMENT file (#62.4)
10. LAB REPORTS file (#64.5)
11. INTERIM REPORTS file (#64.6)
12. LOAD/WORK LIST file (#68.2)

NOTE: Remember that the first seven files must be reviewed/edited in that order. These are the Day One files.

We have included review here, since in most cases you will only have to review the entries in the TOPOGRAPHY file (#61) to make sure the site/specimens you need are there. If you have to add an entry, do it first. The remaining primary files can be modified in any order you wish, with a few exceptions. If you want to put controls on a load or worklist, the entry must be made in the LAB CONTROL NAME file (#62.3) first. In order to specify what load or worklist is run on a particular instrument, you have to build the LOAD/WORK LIST file (#68.2) entry first and then associate it with the correct instrument in the AUTO INSTRUMENT file (#62.4).

To better understand the interrelationships of the files and their corresponding field characteristics, one of the first things you should do is use VA FileMan to obtain a list of file attributes (otherwise known as a data dictionary) for each and every Laboratory package file. These listings will provide the information on type of field, length of field, number of decimals allowed, whether a field requires an entry, input transforms, output transforms, cross references and identifiers, as well as pointers which exist between the files. A good understanding of the files, what information they contain and how they interrelate is important in the implementation process.

Editing the Files

If you have lots of extra time, feeling ambitious, or a stickler for details, you can also modify the other Laboratory package files prior to implementation, although the package initially will be fully functional without extensive editing. Three exceptions here are Microbiology, Anatomic Pathology, and Blood Bank related files. These files should be reviewed and modified before bringing up those portions of the lab package. Specific information about those pre-implementation files can be found in the Microbiology, Anatomic Pathology, and Blood Bank sections in the Planning and Implementation Guide.

Listed below are some suggested steps you should take when adding to, editing, modifying, or otherwise changing any entries in the laboratory package files before and after implementation:

1. FAMILIARIZE YOURSELF WITH THE FILES - list the entries (if any); obtain a printout of the data dictionary for the file; figure out what type of information goes into the file.
2. GATHER APPROPRIATE INFORMATION - compile and organize the necessary information for editing the file; consult existing lab documentation and procedures; consult with department personnel from each area of the lab.
3. EDIT THE FILE - add new entries or modify existing entries; **DO NOT DELETE** existing entries unless absolutely necessary; consult with your site manager or regional ISC for any questions or problems. **BE CAREFUL!**
4. DOCUMENT YOUR WORK - obtain new copies of any and all file listings and printouts for reference after making any changes.
5. CHANGES AFTER GOING LIVE - determine what other file(s) (if any) will be affected by the change, **always** make any changes to the day one files in the specified order, and document your changes (what fields and files, as well as the date).

NOTE: For a complete description of each field in the LABORATORY files (#60-#69.91 and #95), see the Planning and Implementation Guide.

General Laboratory

Menu Description

Familiarize yourself with as many of the options available as possible in the exported package. The more you review and practice, the more benefits you will gain from all the time you spent modifying the lab files. Even the most carefully defined database would not be much help if the lab personnel do not know how to **use** the package.

The laboratory options are exported as menus which group the options with similar functions together into general categories, as follows:

Menu	Function
Laboratory DHCP Menu	This is the primary menu options
Phlebotomy Menu [LR GET]	Options the lab uses to get (collect) the test orders and specimens
Accessioning Menu [LR IN]	Options the lab uses to put the orders in (enter into) the system
Process Data In Lab Menu [LR DO!]	Option the lab uses to do (process) the work on the specimens
Quality Control Menu	Options for maintaining quality assurance
Results Menu [LR OUT]	Options the lab uses to report or send out patient test results
Information-Help Menu [LR HELP]	Options the lab uses to obtain additional "help" or information about tests, orders, make inquiries, etc.
Anatomic Pathology [LRAP]	Options used by the Anatomic Pathology module
Blood Bank [LRBL]	Options used by the Blood Bank module
Microbiology Menu {LRMI}	Options related to the microbiology section
Supervisor Menu [LRSUPERVISOR]	Options used by supervisors to perform specialized functions in the lab
Ward Lab Menu [LRWARDM]	Options used by the ward personnel to place orders, make inquiries, etc.

Laboratory Security Keys

The laboratory package supplies various security keys that act as follows:

- Some routines check for user security keys. If you do not have the appropriate security key assigned to you, the routine will not work for you.
- Certain options and menus are **locked** with security keys. These keys are used as locks for particular options, and are also checked elsewhere during the execution of the option. In some cases, the lack of the appropriate security key will prevent you from seeing an option even though you have been assigned a menu that normally contains that option.

Each user of the Laboratory package must have the appropriate security keys assigned before accessing the package. The SECURITY KEY file (#19.1) contains the key names with a short description. The following is a list of the Lab keys:

KEY	USERS
LRANAT	Anatomic Pathology users
LRAPSUPER	Anyone allowed to use the Anatomic Pathology Supervisor Menu and edit SNOMED codes
LRAU	Autopsy Module users
LRBLOODBANK	Blood Bank users
LRBLSUPER	For Blood Bank supervisory level decisions
LRCY	Cytology Module users
LREM	Electron Microscopy Module users
LRLAB	Laboratory Personnel only
LRLIASON	Laboratory Information Manager*
LRMICRO	Microbiology users
LRMIVERIFY	Microbiology personnel
LRSP	Surgical Pathology Module users
LRSUPER	Laboratory Supervisors
LRVERIFY	Anyone who is authorized to verify lab results
LRPHMAN	Phlebotomists
LRPHSUPER	Supervisor of the phlebotomy collection team

Any combination of the above security levels may be used, as deemed appropriate by the Laboratory.

* Highest security level of all keys. The Laboratory Information Manager* key should be reserved for LIM and IRM Support staff.

Workload Recording

The DHCP Laboratory Workload recording and reporting system is a flexible and comprehensive technique for capturing work performed. The system covers all areas of the laboratory, both clinical and anatomical. Although differing methods for capturing the workload data are used, all data is uniform in structure and content. The level of reporting may be general or specific depending on how the files are setup. The data is designed to allow either gross bottom line figures or highly detailed line item reports.

There are four levels of data concentration or reporting levels.

1. National level
2. Administrative level (Site specific)
3. Lab section level
4. Accession level (data for each patient sample)

The highest report would be the “National level” and it is similar to the AMIS report. This report supplies total work load for the reporting institutions. Various miscellaneous reports could be obtained from the national roll-up data base as needs are identified. The report would be used by offices dealing with national and regional issues (i.e., Regional Director, Central Office).

The next lower reporting level would be the “Administrative level” which contains site specific data in more detail. Administrative reports contain data dealing with ordering location, or time of day work was completed. This type of report can be used by the hospital director, chief of staff, or Laboratory service.

The next reporting level is of the most benefit (internally) to the laboratory service would be the “Lab section level”. The site can then control the level of granularity they wish the data to be collected. This level contains all information known about the work performed except the patients identity and accession number. There could be several reports dealing with specific areas or sections of the laboratory. Reports may be generated for a particular bench or workstation.

The lowest reporting level is of the most benefit to lab supervisors would be the “Accession level”. This data level is the most detailed, and includes more than 30 data elements at this level. There are a wide variety of potential views of the data collected, and unique displays can be devised by the user. Remember this level contains the patient identity and the accession numbers.

All levels of reporting below the national level (the highest collecting point) can be manipulated via VA FileMan sorts and prints, thus allowing ad hoc reports to be designed by the reporting sites. The data structure is flexible and standard, providing data that is standardized at the national level yet customized at the site levels. The degree of granularity at the site level will not effect the data at the national level. The data collected at the national level will be consistent and standardized.

To achieve standardized and consistent data content at all levels, the schemes outlined in the “Manual For Laboratory Workload Reporting” published by the College of American Pathologists (CAP) was used. This manual outlines methods for identifying and collecting workload. The terminology, categories, methods, etc., were adopted into the DHCP reporting methods. The elements of the most current CAP manual are loaded into DHCP files. The CAP manual represents the seed for the DHCP National Laboratory Test File. From this basic guideline, additional data elements are collected to satisfy specific concerns of Department of Veterans Affairs. It is recommended that the LIM get a copy of the manual and review it before implementation. Using a functional specific outline by the Laboratory program office, a system of data collection and tabulation was devised.

The actual process of data collection is designed to relieve the verifying technologist of as much of the burden of additional work tasks or key strokes. The technologist need only to answer one or two additional questions while in the course of normal activity to trigger data collection. Additional keystrokes will be necessary to capture many non-routine procedures. The collecting process is virtually transparent to the technologist. The collecting system has a great deal of flexibility inherently designed into it, thus allowing each site the ability to tailor their system to their particular work flow.

Although methods of collecting may vary from site to site, the data is comparable to any other site's data at any level. This supports management and functional needs without regard to data source. If a particular procedure and method is performed at one site, it will be identified the same way at any other site.

Approximately 80-85% of workload data is collected automatically by the system. The remaining 15-20% can be entered into the system manually. This feature allows for input during periods when the system was unavailable to capture the data automatically.

As new instruments, techniques and procedures become available, new workload code will be distributed via national releases. This ensures that data remains standardized and consistent for site to site. A procedure for coordinating DHCP activity and the College of American Pathologist will be worked out to remove any conflicts of methods and terms.

For Blood Bank, Cytology, Surgical Pathology, EM, and Autopsy sections, you will have to add necessary tests as specified to capture workload. See details in the individual sections.

NOTE: For further detail on the implementation of Workload, please see the Planning and Implementation Guide.

Lab Labels

There are seven lab label types available for use in the Laboratory package. Only one of these label types can be used at any given time. The label type is defined in the LABORATORY SITE file (#69.9).

Barcode labels are now supported, not all labels are distributed with barcode functionality.

- 3.5 X 15/16 Accession # 1st (LRLABEL):** This is the default label if no label is entered in the LABORATORY SITE file.

Example:

HE 0904 ET	AAA,A 09/04/88
	000-11-1222 W:OLD
B:4401-C	LAVENDER Order:
1101	CBC

- 2 X 5 UNEVEN (LRLABEL1):** This is the 10-part SLC label at 16.5 CPI, with 1 label printed for every four tests on the accession.

Example:

AAA,A	CH 0910 2	CH 0910 2	CH 0910 2	CH 0910 2	CH 0910 2
000-11-1222 W:1B	09/10/88	09/10/88	09/10/88	09/10/88	09/10/88
SMALL RED TOP Order: 1118		AAA,A	AAA,A	AAA,A	AAA,A
CHEM 7		RED TOP	RED TOP	RED TOP	RED TOP
AAA,A	CH 0910 2	CH 0910 2	CH 0910 2	CH 0910 2	CH 0910 2
000-11-1222 W:1B	09/10/88	09/10/88	09/10/88	09/10/88	09/10/88

- ORDER # FIRST (LRLABEL2):** The order number appears on the top line.

Example:

Order: 1101	
AAA,A	
000-11-1222 W:OLD	
HE 0904 35	LAVENDER
CBC	

Microfiche of Path Reports

The storage of Anatomic Pathology reports over a number of years requires a considerable amount of space for the bound volumes, whether they are all retained in the Pathology Service or stored off-site. Other methods of compact storage can greatly economize on use of this space. Some such methods include microfilming and microfiche. Newer techniques such as compact laser discs are emerging, and may already be available, but at considerable expense. This section provides instructions for setting up and using microfiche within the Anatomic Pathology module of the Laboratory package.

Microfiche and microfilming are technologies well developed at this time and are relatively inexpensive. Many hospitals are using these techniques in various departments on a daily basis, even those which are computerized. The equipment and service costs to microfiche anatomic pathology reports are reasonable and can be accommodated by almost any budget.

A microfiche reader-printer in the Anatomic Pathology department is an absolute necessity for using microfiche. Reader/printers range in cost from about \$550 - \$600 for the low usage installations, and from \$2500 for the higher volume pathology laboratories. A Xerox or copy machine, which is accessible in most hospitals, is a helpful adjunct.

For further information, please see the Planning and Implementation Guide.

Cumulative Report

The cumulative reports are a printed accumulation of laboratory test results that have been reported (verified) during a given time interval (usually one day). With these reports, it is possible to see trends in laboratory results over a period of time. New data is displayed together with previous data so that the ultimate result is better patient care. Another feature is the ease with which results can be retrieved in a patient's chart. Some sites may choose to print these reports daily. While others may choose to print them Monday-Friday only.

The cumulative is generally printed alphabetically by location. Within each location, it is printed alphabetically by patient name. When the location is FILEROOM, the cumulative prints by the last four digits of the patient's SSN# (sorted by last 2, then the next 2 digits). The report is designed to replace the usual lab reporting slips that are filed in the patient's chart. With these reports, it is possible to see trends in lab data over a long period of time. The LAB REPORTS file (#64.5) is used to define a site's cumulative report.

The fields that must have entries in LAB REPORTS file (#64.5) are:

Lab Report Name: For each printer that you set up, you will need a lab report name. An entry here allows you to designate a device for printing and a range of locations to print for each device.

Device: Name of printer to be used.

Starting Location: First location to print to the device.

Ending Location: Last location to print to the device.

If you have decided to start your cumulatives by the using the Manual queuing of cumulative [LRAC MANUAL] option, this is all you need to set up.

Further Cumulative Functionality (Version 5.2)

With Version 5.2, the capability to print the FILE ROOM cumulatives at a different time from the INPATIENT cumulatives exists.

Two new functionalities exist.

1. Inpatients and separate locations print on one time schedule and all other outpatients print on another schedule. For the outpatients to print on the different schedule, the following file entries **must** exist.

64.5,4 (File Room) =“YES”

64.5,17 (Separate File Room) = “YES”

Reports multiple has File Room 1 and File Room 2 with 64.56,3 (FileRoom Report) =“YES” in each Starting and Ending location containing “FileRoom”

2. Inpatients and separate locations print on one time schedule, one set of outpatient reports print on a different time schedule, one location and another set of outpatient reports print at the same time of the other outpatients but at a different location. This is done by filling out 64.57,1 (Alternate File Room).

Fields for Fileroom Cumulative (LAB REPORTS file (#64.5))

A. File Room Report Date field (#16): This field is used if the site prints the FILEROOM location on a different schedule than the regular Cumulative print. If this feature is utilized, the last date the FILE ROOM location(s) were printed is stored in this field.

B. Separate File Room field (#17): This new field is used to designate the FILE ROOM cumulative being printed on a schedule different from the regular cumulative. To utilize this feature the following needs to be setup.

C. File Room Report field (#3) in Report Name multiple field (#2): This new field is used to designate a report to print a file room location. It is used in conjunction with File Room field (#4) and Separate File Room field (#17). It allows the cumulative to identify those reports which should be run when a site wishes to print the file room reports and they are doing so on a schedule separate from the regular cumulative.

D. Alternate File Room field (#1) in the Separate Report Location multiple field (#6): This new field is used to designate those locations which a site wishes to print to a “FILE ROOM” location but which they do not wish to be a standard file room. This could be sites which have satellite clinics which have their own file rooms. The name entered here will cause this location to be sorted to a location called “FILE ROOM_ alternate file room name” followed by a “1” or “2”. The patients will be sorted in terminal digit order similar to the regular file room. This requires that the site has File Room field (#4) set to “YES” to sort non inpatients to location “FILE ROOM”.

Setting up the files

1. Set Separate File Room field (#17) to "YES" - this tells the cumulative that you are printing the FILE ROOM on a schedule different from the regular cumulative schedule.
2. For regular FILE ROOM patients, set up one or two reports as follows (FileMan requires the different names):

If one report: starting location: FILE ROOM1
 ending location: FILE ROOM2

If two reports:
 first report: starting location: FILE ROOM1
 ending location: FILE ROOM1

 second report: starting location: FILE ROOM2
 ending location: FILE ROOM2

Define the other fields as with a regular report.

3. Set File Room field (#4) to "YES" - this old field allows the program to sort all non-inpatients to two locations, FILE ROOM1 and FILE ROOM2, based on terminal digit of SSN.
4. If you also want to print certain locations to an alternate file room, such as a file room at a satellite clinic then in addition to #2 above, perform the following:
 - A. Enter the location(s) that you want to print as a separate report location by entering them in the Separate Report Location field (#6).
 - B. Enter in Alternate File Room field (#1), the name to use for this File Room. This name will be concatenated with "FILE ROOM".

Example: DALLAS OPC would result in file rooms FILE ROOM_DALLAS OPC1 and "FILE ROOM_DALLAS OPC2."

NOTES:

- The "_", underscore is used to insure that these locations sort after the regular file room locations.
- Two locations for each file room would be created based on terminal digit of SSN or identifier (non PATIENT file (#2)) similar to the regular file rooms. These locations will print on the same schedule as regular file rooms. Either set up separate reports to print these locations or utilize reports defined in Step #3 above and alter the ending location to include these locations.

5. On each report, set the File Room Report field (#3) in the Report Name multiple field (#2) to "YES".

The cumulative software will check when attempting to print a cumulative for a location that contains the name "FILE ROOM" in the following. If Separate File Room field (#17) is set to "YES" and the report being run is not set to "YES" for File Room Report field (#3) then it will skip running the cumulative for that location. This is to prevent another report which may print locations "A" thru "Z" from printing the file rooms unintentionally.

Example: Sample of a filled in file

```
Select OPTION: ENTER OR EDIT FILE ENTRIES

INPUT TO WHAT FILE: LAB REPORTS// <RET>
EDIT WHICH FIELD: ALL// 17 SEPARATE FILE ROOM
THEN EDIT FIELD: 2 REPORT NAME (multiple)
    EDIT WHICH REPORT NAME SUB-FIELD: ALL// .01 REPORT NAME
    THEN EDIT REPORT NAME SUB-FIELD: 5 STARTING LOCATION
    THEN EDIT REPORT NAME SUB-FIELD: 10 ENDING LOCATION
    THEN EDIT REPORT NAME SUB-FIELD: 3 FILE ROOM REPORT
    THEN EDIT REPORT NAME SUB-FIELD: <RET>
THEN EDIT FIELD: 4 FILE ROOM
THEN EDIT FIELD: 6 SEPARATE REPORT LOCATION (multiple)
    EDIT WHICH SEPARATE REPORT LOCATION SUB-FIELD: ALL// .01 SEPARATE REPORT
LOCATION
    THEN EDIT SEPARATE REPORT LOCATION SUB-FIELD: 1 ALTERNATE FILE ROOM
    THEN EDIT SEPARATE REPORT LOCATION SUB-FIELD: <RET>
THEN EDIT FIELD: <RET>
STORE THESE FIELDS IN TEMPLATE:

Select LAB REPORTS NAME: CUMULATIVE REPORTS
SEPARATE FILE ROOM: YES// <RET>
Select REPORT NAME: FILE ROOM1// <RET>
    REPORT NAME: FILE ROOM1// <RET>
    STARTING LOCATION: FILE ROOM1// <RET>
    ENDING LOCATION: FILE ROOM1// <RET>
    FILE ROOM REPORT: YES// <RET>
Select REPORT NAME: <RET>
FILE ROOM: YES// <RET>
Select SEPARATE REPORT LOCATION: CARDIOLOGY// <RET>
    SEPARATE REPORT LOCATION: CARDIOLOGY// <RET>
    ALTERNATE FILE ROOM: EEE TEST// <RET>
Select SEPARATE REPORT LOCATION: <RET>
SEPARATE FILE ROOM: YES// <RET>
```

Changed routines

1. Routine LRAC changes:

- A. Code to prevent selection of file room reports if printing on separate schedule.
- B. Task separate file room reports both using tasked option and manually.

- C. Includes the last file room patient list in building the current list. Same criteria apply, if the report date is greater than the report date stored for the patient then it is added to the list. This was to catch any patients who are on the previous file room cumulative but were not actually printed. If for some reason a patient is not printed, they will roll forward to the next cumulative list.
2. Routine LRAC1: Code to check if report and location are file room and is this a file room report. Will skip location if it is not suppose to print.
 3. Routine LRAC8: Routine to only go thru LAC global once when checking for header changes. Previously it would go thru global for each change. If more than one change would increase delay in starting the printing by factor of the number of changes. This routine allows the LIM to make multiple changes without adversely delaying start on cumulative.
 4. Routine LRACK:
 - A. Routine to check if separate file rooms are implemented and only clear those reports which are not file room.
 - B. Changed cumulative device status report to print manual print and file room report fields, separate file room turned on and last file room report date.
 5. Routine LRACKL1: Routine to check if site wants alternate file rooms in addition to regular file rooms. Checks separate locations for alternate file room name.
 6. Routine LRACM2F
 - A. Display the date of last cumulative (REPORT DATE) when asking for report date.
 - B. Allow user to select multiple locations or all locations. When printing file rooms on a separate schedule, the list can get quite long.
 - C. Patients are numbered within location, corresponds to display when user uses reprint option. Also tells you how many patients in each location. Total of all patients and number processed at end of report.
 - D. If user prints only some locations then report indicates those locations printed.
 - E. On FILE ROOM patients, the report prints the patients SSN not the sorted terminal digit number. The reports still come out in the sorted terminal digit number order.
 - F. If printed to a terminal, does page breaks at end of page.

G. If location continued on successive pages, locations marked as continued.

H. Prints date/time report is generated and report date.

These are the tasked and interactive options to control printing of the File Room Cumulative:

1. NAME: LRTASK CUM FILEROOM

MENU TEXT: Task Cumulative Fileroom Report

DESCRIPTION: This option is used to print fileroom cumulative patients. This option determines the last time the fileroom patients were printed. It then identifies all fileroom patients that require printing since the last run and moves them into the patient list for the most recent cumulative run. Finally, it queues a task to print these patients to specified printers.

WHEN THE LAB REPORTS FILE HAS BEEN PROPERLY SET, THIS OPTION WILL ALLOW THE PRINTING OF THE FILEROOM CUME ON A DIFFERENT SCHEDULE THAN THE INPATIENT CUMES.

**The manual version of this option is LRAC MANUAL FILE ROOM CUM. This option is designed to be tasked. The manual version SHOULD NOT be tasked.
ROUTINE: CLOCK^LRACFR**

2. NAME: LRAC MANUAL FILE ROOM

MENU TEXT: Manual queuing of File Room cumulative

TYPE: run routine

DESCRIPTION: This option is the manual version of the LRTASK CUM FILEROOM option. If you do not wish to schedule automatic printing of the fileroom cum via the LRTASK CUM FILEROOM option, you may use this option instead. This option should never be tasked. There are some questions asked when this option is used. When the proper file setup as been done, this option will allow the printing of the file room cum on a different schedule than inpatient cums.

ROUTINE: LRACFR

TaskManager

The TaskManager can control the printing of the cumulative by means of LRTASK CUM option in OPTION file (#19). Although the time interval between prints is usually one day, it may be set to any time period convenient to your station. The output device can be any printing terminal.

The cumulative has the ability to print portions of the report to different devices, thereby sending reports to locations near where they will be needed.

Example: Locations ranging from A to LZ can be sent to device A and locations ranging from LAX to ZZZ can be sent to device B. Or a remote site can specify a printer at the remote site. Dividing the task between printers and CPUs will optimize the run-time required for the cumulative.

Automatic queuing of the report is done using the LRTASK CUM options. The fields QUEUED TO RUN AT WHAT TIME and RESCHEDULING FREQUENCY in the OPTION file (#19) need to be set up appropriately. This option will then spawn reports for all devices defined in the Lab Report Name field of the LAB REPORTS file (#64.5), with the exception of those reports that have an entry in the Manual Print Field of the LAB REPORTS file (#64.5).

If you want to queue a device on another CPU, the DEVICE file (#3.5) on each CPU must have the queued device as one of its entries with the field OTHER CPU containing the Volume set of the other CPU.

Device Parameters

The device parameters for all devices that print (or reprint) the cumulative should be the same. Because paging and permanent determinations are made at the time of printing, the device parameters (IOM, IOSL, CPI, LPI, etc., see the VA FileManager Programmer Manual for a discussion of these parameters) need to remain constant.

When initially setting up the device parameters, there are no restrictions on selection of lines per inch, characters per inch, form length, or form width. If you are using profiles that are large and require multiple lines of headings (horizontal format), then it is suggested that you use eight lines per inch and possibly greater than 80 columns in your definitions to accommodate more data per page.

The cumulative should not be sent to a CRT except for testing purposes. If you do specify a CRT, you will need to redefine the lines per screen and number of columns to emulate a printer.

The horizontal display uses the variable IOM (right margin) to decide when to break a line of tests into a second line. If a line of tests is too long to fit on one line, changing the value of IOM (through the DEVICE file (#3.5) or when prompted with "DEVICE:") may get all the tests on one line. Be sure to choose the correct pitch on the printer that you are using.

The vertical display calculates the number of data columns, based on the total number of columns defined in IOM. Likewise, by manipulating the page length (IOSL), you can reduce or increase the number of sets of data to be printed on a given page.

Once these parameters have been determined and you are in production, they should not be changed. It is critical if another printer is used, that the parameters are identical to the previous printer.

☛ **WARNING:** This rule applies to new, additional, or different printer devices. Otherwise the cumulative report may be seriously affected.

Initialize LAC Globals & X References [LRAC INITIALIZE]

This option is used when the medical center is ready to begin actual charting of the daily cumulative. It may be run multiple times to restart the page numbering during the testing phase of implementation. Once actual charting has begun, **IT SHOULD NEVER BE RUN AGAIN!** While all pages are numbered and dated, the potential for confusion is obvious.

☛ **WARNING:** Once in production, this option **should be removed** from menus or disabled!

Interim Reports

Interim reports are designed to display or produce a printed report of verified lab results that occur in the interim of the running of the cumulative. These reports are in a different format from the cumulative and should not be charted.

It is most important to remember that the interim was not intended to keep up with patient movement. The location entered during the accessioning process will be the location used for printing purposes.

Interim reports will include comments from LABORATORY TEST file (#60), Site/Specimen field (#100), and Interpretation subfield (#5.5). At this time, these comments do not appear on the cumulative report.

Both MI and CH subscribed are available for review with the interim report options. An accession area must have a print order set up in ACCESSION file (#68), for results to print on the interim report. For non lab users (no LRLAB key), only those tests set up as Both or Output in File #60 will print on interim reports. Users having the LRLAB key may see data entered as "Input Only."

Since only verified reports will be displayed, the interim reports will not display the status of tests (i.e., incomplete, testing in progress) and hospital staff should be instructed to check the option "Order/Test Status" before generating an interim.

Interim reports can be printed at various times during the day to a centralized printer. Printing is controlled by the LRTASK options, run by TaskMan, and the INTERIM REPORTS file (#64.6). The appropriate LRTASK option should have Fields #200, #201, and #202 filled in with the tasking information. File #64.6 needs to have locations defined for which interim reports are printed, and the HOSPITAL LOCATION file (#44) must also have the Abbreviation field filled in. Whether or not to transmit results immediately upon verification and whether or not to include location on interim reports is also defined. In order to transmit results upon verification, the Que Verified Test(s) fields in the LABORATORY SITE file (#69.9) needs to contain a value of "YES". If an accession area does not have a print order, the results for that area will not be printed on the interims.

There are several ways to generate interim reports:

- Called up automatically for various times of the day using TaskManager
- Printed as reports become available (Immediate Interims)

The automatic interim report feature allows a site to select a range of urgencies to print. A field is available in File 64.6 called Urgency Cutoff. This field can be used to establish a range of urgencies to print automatically to a certain location (i.e., If Stat = 1, Pre Op= 2, Routine = 3, and Pre Op is entered into this field, then any urgency less than or equal to 2 will print automatically. The numeric designation is assigned during the enter/edit process on creation of the urgency in the URGENCY file (#62.05).

When deciding to use the automatic interim feature, please keep in mind that every time a test is verified, reverified, etc., a report will print. If you have several tests per accession number and each test is verified separately, you will generate a sheet for each time a test on the accession number is verified.

- Called up manually through a menu option for either one patient, a hospital location, or by physician.

Those using the interim for lookup purposes (other than Interim Report for Selected Tests as Ordered [LRRSP]), you need to remember that the dates used in the selection for review are the collection date and time. All interim reports print in inverse date order. This can be very frustrating if your Lab routinely holds tests over for batching purposes. If you verify a test today but it's collection time is last week, it will not print with today's interims since the interim option works from the collection date and not the verify date.

Both MI and CH subscribed tests can be available for review with the interim report options.

Tasking the Interim

There are two different interim reports that can be tasked. There is the tasked batched interim which is generated at a particular time of day and another interim that is called an immediate interim.

Immediate Interim

You must edit several files or have the files edited.

File (#69.9): Field:Que Ch, He Etc. Verified Test(S)
Field:Que Micro Verified Test(S)
These fields must be set to "NO" if you do not want the interim to print automatically.

File (#64.6): Field:Location
Must contain the location name that acts as a pointer to File #44.
Field:Immediately Transmit Results
Must be set to "YES"
Field:Device
Field:Urgency Cutoff
All reports will print if field is blank. When it has an entry, only higher urgencies will print

Batched Interim

Batched Interim can be set up for various times of the day to a centralized printer.

NOTE: This device is set up in File #19 under the option name and is NOT that designated in File #64.6.

The information that will print on this report will be the verified data for that day, from midnight until the time of printing. If you elect to have more than one printing each day, you will not get just the reports since the time of the last printing but all verified results for the day. The printing will occur alphabetically by location and within each location, alphabetically by patient name.

File (#64.6) Field:Location
Must contain an entry for each ward location

Field:Interim Reporting must contain "YES".

File (#19) Option Name: LRTASK Daily Interim 1, Fields #200, #201, and #202 must contain entries. These fields are for device, frequency (once a day, once a week), and time. For each interim time of day, you will need a different tasked option. (e.g., LRTASK daily Interim I, LRTASK Daily Interim 2, etc.)

LAB TEST CYCLE CHART

Lab Test Cycle Chart

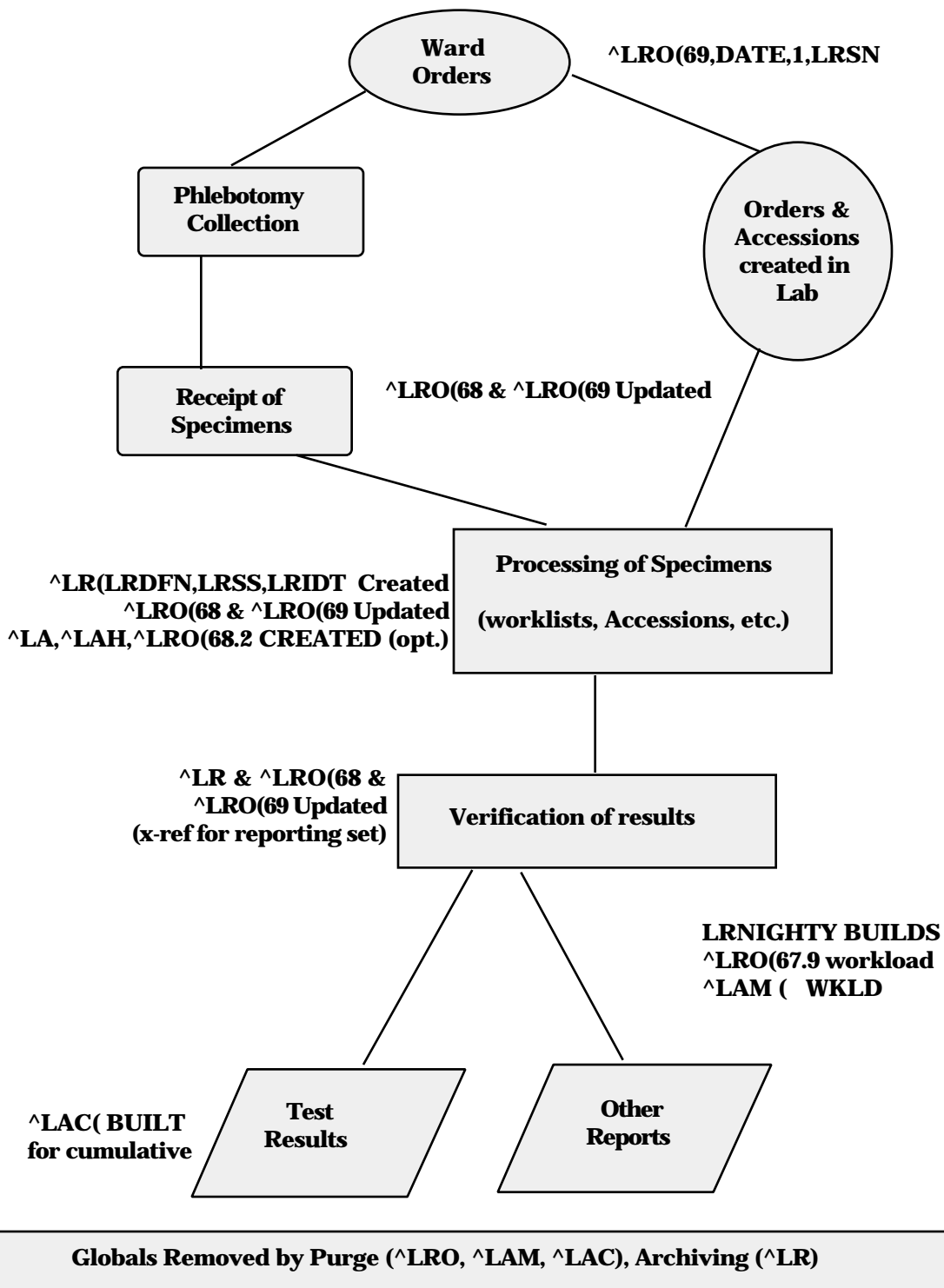

INSTRUMENTATION AND INTERFACING

Instrumentation and Interfacing

Introduction

Since interfacing instruments is such an important part of the modern laboratory, all users should be familiar with the process of “interfacing” and why it is not just a “plug the machine in” process as many instrument sales representatives claim.

Supervisors/Choosers of Instrumentation

☛ **WARNING:** If you are involved with selecting an instrument to use in your Laboratory, be aware that there are three possible scenarios facing you when you decide to interface.

1. There is a completed approved interface routine written for that particular instrument. It may be unidirectional or it may be bidirectional, but either way, it has been tested and works at other DHCP sites.
2. There is an interface routine written for that particular instrument but it has not been completely tested. It may still be in Alpha test (first try) or Beta test (later tries). In this case, you have the option of waiting until other sites finish the testing or becoming an Alpha/Beta site. If you choose to become a test site, you will have to commit your time and IRM time to checking the data for problems and working with the developer to correct those problems.
3. There is not a interface routine written for that particular instrument. In this case, you can become an Alpha site yourself or you can wait until another site purchases the instrument, goes through the process of having the routine created and approved. If you choose to become a test site, remember that you will have to commit your time and IRM time to checking the data for problems and working with the developer to correct those problems.

NOTE: Remember, a DHCP routine must exist in order for you to effectively interface your new instrument.

It does not matter that the Manufacturer Sales Representative says that it can be interfaced. (To most Sales Representatives, that means the instrument has a RS-232 plug in the back and it can be connected to an outside computer with a standard communication line.) Without the interface program to “translate,” your DHCP system will not understand what the instrument “is saying” and where to store the data.

Load/Work Lists

The LOAD/WORK LIST file (#68.2) controls the building and printing of load/work lists. Each automated instrument has to be linked to a load/work list entry. For each load/work list entry, there is at least one profile that lists the tests and controls that are used with that profile on that load/work list. In normal operation there is at least one load/work list and profile per type of instrument and one for each bench.

For example, a multiple profiles for a load/work list might be a particular kind of test that is run on a weekly basis; e.g., a Thursday profile. At other times during the week, it is run with another profile. The definition of the profile determines what tests are going to be pulled out of the accessions to be included on that load/work list. You predefine all the various ways that you will reference that test. You may use synonyms, define it as parts of profiles or subparts of other panels or profiles in the LABORATORY TEST file (#60).

You need to specify individually in the load list Profile field (#50) those tests that need to be verified. The Build Name Only field (#2) in LOAD/WORK LIST file (#68.2) is a "YES/NO" question. If you answer "YES" the test (either single or a panel) will be used only to build the profile for the load/work list. If set to "NO", (and the test is a single test), then the sequence of tests on the profile will be defined by the order in which they are added to this field. If set to "NO", and the test is a panel, the test sequence will be defined by the order in which they have been added to the panel test name in LABORATORY TEST file (#60) in the Lab tests included in Panel field (#200).

For example, if you enter a load/work list for Electrolytes and define one profile for the list, also called Electrolytes. Into this profile you will be putting the **single tests** Na, K, Cl, and CO₂ from LABORATORY TEST file (#60). Set these tests BUILD NAME ONLY=NO. Also, add the panel LYLES which includes all these tests and set its BUILD NAME ONLY=YES.

Instrument Data Flow

The general flow of data from the instrument to the computer to verification is described here. The first staging of the data is in the LSI INTERFACE. The data is stored with a flag as to what hardware port the data came from. The data is sent from the LSI INTERFACE to the host system one at a time (with handshaking) by the LAB routine and then goes into the ^LA global with the first subscript representing the individual instrument line using the internal entry # for the instrument from the AUTO INSTRUMENT file (#62.4). This data is then processed by a special routine for that instrument and the processed data is stored in the ^LAH global until it is verified by a lab tech or deleted. When no data has accumulated for approximately 3 minute, the ^LA global for the instrument is deleted and completely removed.

The LAB routine runs continuously and looks for data from the LSI INTERFACE. As soon as the LAB routine receives data from the instrument, it starts putting the data into the ^LA global, subscripted by instrument number, and simultaneously executes the NEW DATA node for this instrument in the AUTO INSTRUMENT file (#62.4) to start up the routine responsible for processing the data out of the ^LA global. The data that is contained in the ^LA global is the raw instrument data. If additional data is coming in from the same instrument and the ^LA global already exists, the LAB routine does not restart a new routine. The new data continues to be accumulated in the ^LA global. This means that if data already exists in the ^LA global and the routine is not running for that instrument, data will continue to accumulate in the ^LA global, but will not be processed out. This situation will exist until the LRJOB function is run to start the proper routine.

The running of the appropriate routine processes the data out of the ^LA global and stores the data in the ^LAH global. This is a temporary storage area. The AUTO INSTRUMENT file (#62.4) contains information on the tests that are run, where in the input string the test value is located, and where to store the data in the ^LAH global. This is the same as the location used in the ^LR global. Also there is a pointer to the LOAD/WORK LIST file (#68.2) that gives the subscript for the ^LAH global, what method to use in linking the data to a sample in the ACCESSION file (#68), whether to OVERLAY data and whether to process by accession number, sequence number or tray cup. The first subscript of the ^LAH global is tied uniquely to a given load/work list. If data is NOT overlaid, then each new sample's data will get a new entry in ^LAH. If the data is to be overlaid, then a new entry will be made only if the linking variable cannot be found in the file.

☛ **WARNING:** Neither ^LA nor ^LAH is VA FileMan compatible.

The processing of the data out of the ^LAH global is usually done during verification of instrument data. If not, it accumulates data for a day or until the CLEAR INSTRUMENT function is done. When the instrument data is cleared, data in ^LA, ^LAH is purged. Upon verification, the data from ^LAH is moved into the ^LR global. This global, ^LR(, LAB DATA file (#63) is VA FileManager compatible. All data that remains unverified stays in the ^LAH global.

To avoid confusion with data from the previous shift, the Clear Instrument/Worklist data [LRINSTCLR] option should be run at the beginning of every day (or perhaps, every shift). For example, if there is an accession number 120 verified, then that data still exists under that accession number. If you then run a new accession number 120, you would get the data from the previous accession number 120. If you ran another sample through the system for accession 120 for the current time period, you would then have two sets of data for the accession number 120. If you have ROLLOVER specified in ACCESSION file (#68) and the data is unverified, you would not be able to create a new 120. This is complicated by the fact that the AUTO INSTRUMENT file (#62.4) allows two ways of running the programs, one of which is that every sample gets a unique entry in the ^LAH global, even if it belongs to the same tray and cup and to the same person. This means you can consecutively accumulate multiple copies of data. The technologist then must make a decision about which set of data or combination of sets is correct. This cannot be batch verified. To avoid this situation you clear the instrument using the Clear Instrument/Worklist data option.

Verification (and movement of data from ^LAH to ^LR) can be accomplished two ways:

1. Use the Enter/Verify Data (auto instrument) option. This takes one accession number, one sequence number, or one tray/cup at a time, displays the data and asks for verification. When it is verified, it moves to ^LR and is then available to the wards, on cumulative reports, etc.
2. Use the Group Unverified Review (auto instrument) option. This prints the data from the ^LAH global. You may check it for critical values, delta checks, etc. When you are ready to verify all or parts of the data, use the Group Verify (auto instrument) option to verify it and move it to the ^LR global. You cannot group verify data that has multiple entries of data not overlaid. If there are cases of multiple sets of data, the group verify skips the data and notifies you. The technologist must make the decision as to which data to use. To do this, use the Enter/Verify (auto instrument) option to make a manual selection.

If the Overlay Data field in the AUTO INSTRUMENT file (#62.4) is set to "YES", then a test is overlaid by a new run of the same test. If, for example, you get an out of range check, you can rerun the sample and the values will replace the previous values. This is done for all values that are transmitted from the instrument. To correctly use this method, you must remember that new data substitutes for old data (that is, new data writes over existing data).

Automated Instrument Interfacing

The LAB routine ties a port to the LSI device (data concentrator). If multiple LSI devices are used, corresponding multiple LAB routines would have to run, and each would be designated separately (i.e., LAB1, LAB2, LAB3, etc.). They are all identical except that each one increments by 10 the internal count on the first subscript of the ^LA global. Data goes across the line that is specified as the beginning lab data line (specified in the device file). Because it goes by name (LABDATA) rather than by line number, it is always LABDATA, LABDATA1, LABDATA2, etc., depending on which line you are using.

When the LAB routine is running, any data that comes from a given line hooked to the LSI goes to the same designated number line in the ^LA global; (i.e., if it comes out of line number 5 it would go into ^LA(5,. At the same time, if this is new data and nothing exists in the ^LA(5, global), the LAB program starts up whatever appropriate automated instrument routine belongs to number 5 as defined in the AUTO INSTRUMENT file (#62.4). The AUTO INSTRUMENT file (#62.4) is number meaningful in that the Field #.001 is defined. The individual entries tie to individual devices. For example, if you have multiple Coulters, you would have multiple entries with a different name for each Coulter, in the AUTO INSTRUMENT file (#62.4) (e.g., coulter1, coulter2). It is essentially a one to one mapping of line to the specific instrument.

If the data is already defined in the ^LA global and the processing routine is not running, data will continue to accumulate in that ^LA global and nothing will happen to it. The LAB program assumes that the target global already exists and the processing routine is running. If the target global does not exist, it assumes that the program is not running and tasks the routine to process that global.

AUTO INSTRUMENT file (#62.4) determines what load listing mechanism it is supposed to use for moving the data in the ^LAH global. The ^LAH global is defined in the LOAD/WORK LIST file (#68.2). The ^LAH global is a temporary global where data is brought in and retained sequentially. Each succeeding piece of data is stored in the ^LAH global and its first subscript based on the same subscript as the entries in the File #68.2. When the data is verified and placed in the ^LR global, it is removed from the ^LAH global.

NOTE: If you need help with an Auto Instrument, your respective ISC will be very happy if you can supply them a hard copy of the routines being run, a copy of the ^LAH and ^LA globals, parameters from the instrument, version of the software on the instrument, and a hard copy of the AUTO INSTRUMENT file (#62.4).

Automated Instrument Data Flow

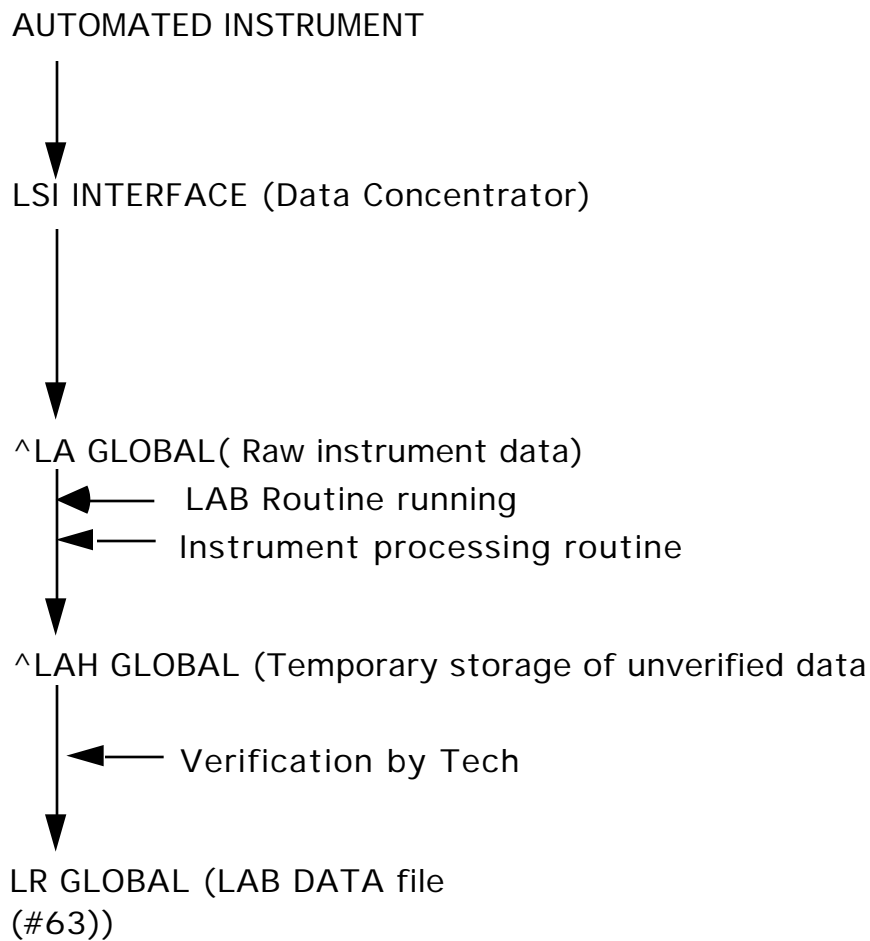

AUTO INSTRUMENT file (#62.4) Fields List

The AUTO INSTRUMENT file (#62.4) contains all specific information related to each automated instrument in the laboratory. It is used to define the site specific parameters by which each instrument will be run, including what automated interface routine program will be used, the type of load or work list that will be run on the instrument, and the individual tests which will generate data from that instrument. The file specifically defines for each instrument the name, echo device, program, load/work list, entry for LAGEN routine, lab test associated with the instrument, WKLD suffix code, and alarm terminal (the alerting terminal when the interface line is not working).

It is necessary to review and edit this file prior to interfacing any automated instruments to be run on-line. For more complete information on how this is accomplished and the implications of editing this file, please refer to the section of this manual entitled Instrumentation/Interfacing.

- (.001) NUMBER
- (.01) NAME
- (.14) WKLD METHOD
- (.15) WKLD CODE METHOD NAME
- (.16) WKLD CODE SUFFIX
- (1) ECHO DEVICE
- (2) PROGRAM
- (3) LOAD/WORK LIST
- (5) ENTRY for LAGEN ROUTINE
- (6) CROSS LINKED BY
- (9) *ECHO ALL INPUT
- (10) METHOD
- (11) DEFAULT ACCESSION AREA
- (12) OVERLAY DATA
- (20) NEW DATA
- (25) RESTART
- (26) HANDSHAKE RESPONSE
- (27) ACK TRIGGER VALUE
- (28) ACK RESPONSE VALUE
- (29) DIRECT DEVICE
- (30) CHEM TESTS (Subfile 62.41)
 - (.001) Number
 - (.01) Test
 - (2) Param 1
 - (3) Param 2
 - (4) Param 3
 - (6) Download Code
 - (11) Routine Storage
- (31) LOAD CHEM TESTS

- (40) ALARM TERMINAL (Subfile 62.42)
 - (.01) Alarm Terminal
- (60) MICRO CARD TYPE (Subfile 62.43)
 - (.01) Micro Card Type
 - (.5) Card Name
 - (.7) Process Card Call
 - (1) Organism (Subfile 62.44)
 - (.01) Organism
 - (1) Card Code For Organism
 - (2) Drug (Subfile 62.46)
 - (.001) Number
 - (.01) Drug
 - (1) Drug Node
 - (2) Param 1
 - (3) Card Code
 - (4) Display Order
 - (9) Section
 - (10) Bit Position
 - (3) Message (Subfile 62.461)
 - (.001) Number
 - (.01) Code
 - (2) Flag Value
 - (3) Message
- (70) INTERFACE NOTES
- (91) DOWNLOAD ENTRY
- (92) DOWNLOAD PROTOCOL ROUTINE
- (93) FILE BUILD ENTRY
- (94) FILE BUILD ROUTINE
- (95) SEND TRAY/CUP LOCATION
- (96) QUEUE BUILD
- (97) MICRO INTERPRETATION CHECK
- (100) METH NAME
- (101) MEAN DATA VALUE 1
- (102) MEAN DATA VALUE 2
- (103) MEAN DATA VALUE 3
- (105) MICRO AUTO APPROVAL METHOD
- (106) DEFAULT AUTO MICRO TEST
- (107) SITE NOTES DATE (Subfile 62.4107)
 - (.01) Site Notes Date
 - (1) TEXT (Subfile 62.41071)
 - (.01) Text

AUTO INSTRUMENT file (#62.4) Fields Description

(.001) NUMBER: The internal number assigned by the system whenever an entry is added. Do not edit.

(.01) NAME: This is the name (3-30 characters) of the instrument. If you have more than one of the same instrument, be sure to designate them; e.g., Ektachem 400-I and Ektachem 400-II.

(.14) WKLD METHOD: This field indicates what method the system should use as a default method for workload identification purposes.

(.15) WKLD CODE METHOD NAME: This field is automatically filled in when a selection of WKLD code method name is made. It represents an eye readable name of the code selected.

(.16) WKLD CODE SUFFIX: This field indicates what suffix should be used as a default suffix code for this instrument.

(1) ECHO DEVICE: Echo of raw instrument data to a CRT or a printer is no longer supported. This field is used when setting up a LSI or a direct connect auto instrument. Refer to the section on automated instrument file set up for more information. This field identifies the device name that the auto instrument data line is connected.

(2) PROGRAM: The free text name of the interface routine (copies of the presupplied entries in this file. If the program (routine) is not listed here in the exported version for your instrument, contact your regional ISC or Site Manager to see whether the appropriate routine is available.

(3) LOAD/WORK LIST: Points to the LOAD/WORK LIST file (#68.2). This is a required field. Choose the load/work list name that will be used for this instrument if you plan to run by list. If you plan to run by accession number, this field must also be filled in with the name of the load/work list, even though you may not use it when running the instrument.

(5) ENTRY FOR LAGEN ROUTINE: Choose from a set of codes based on how you plan to run this instrument. (This entry sets up the correct cross-reference between the raw data and the patient or specimen identification.)

You may have to test different combinations, depending on the particular interface routine and/or the way your instrument transmits the raw data, especially if you are lucky enough to have an older or more obsolete instrument. Check with the instrumentation/interface portion of this guide for more information.

(6) CROSS LINKED BY: This field specifies a variable from the interface program which helps set up the cross-reference between data and sample, and is dependent on the interface routine itself. (See the instrumentation/interface section.)

(9) *ECHO ALL INPUT: If the echo device field has been filled in, answering "YES" will tell the system to echo all data to that device. If you choose "NO", no data will be echoed. This field will be deleted in later version.

(10) METHOD: A free text field (1-20 Characters) specifying the method of the testing performed by the instrument. (It is easiest to fill this in with the instrument name.)

(11) DEFAULT ACCESSION AREA: Points to the ACCESSION file (#68) and defines a default accession area from which the tests run on the instrument are pulled. (If no accession area is specified, as in the case of running by accession, when only the numeric portion of the entire accession is specified, the system will assign that accession number to the default accession area listed here as an entry.) If the load/worklist field has been filled in, this field should match the accession area for that list.

(12) OVERLAY DATA: Setting this field to "YES" will allow data to overlay (or replace) previous unverified data (i.e., when specimens are rerun). If you set this field to "NO", the second set of data will be transmitted **in addition to** the existing data. You would have to clear instrument data to remove the previous data first, and then re-run the specimens, especially if you will be group reviewing and verifying.

(20) NEW DATA: For most instruments, this field will have an entry of D NEW^LASET. This is a string of executable code which is used whenever a new string of data starts to come from the automated instrument.

(25) RESTART: This is a string of executable code which restats everything for this particular instrument if there has been a power failure, or if the routines have become totally lost.

(26) HANDSHAKE RESPONSE: If the instrument requires a handshake response, this field contains the executable MUMPS code to set the response into the variable OUT. S OUT=\$C (6) (OUT contains the ASCII character 6 "ACK")

(27) ACK TRIGGER VALUE: This field contains the ASCII sequence use to acknowledge an auto instrument. Not all instruments utilize this field. This is the decimal value that will trigger the ACK response (0-99).

(28) ACK RESPONSE VALUE: If this instrument setup instructions indicate a standard ACK value is required by the instrument, enter the \$C(X) for the acknowledgment. Not all instrument make use of this field. Where X= the ASCII number of the ACK character.

(29) DIRECT DEVICE: This field is used when bypassing the LSI. It is the name of the device that is used to communicate with a direct connect instrument.

(30) CHEM TESTS (Subfile): This is actually a misnomer - it should read TESTS or LAB TESTS, since the entries in this multiple field specify the laboratory test names which will be run (generate data) on the instrument. (You do not run chem tests on a Coulter!)

(.001) Number: Internal entry number of the test entry in this field, assigned by the system. Can only be changed if you delete the test first, and re-enter it. This number may be meaningful to the auto instrument and how it identifies the test.

(.01) Test: Points to the appropriate test(s) in the LABORATORY TEST file (#60). Again these entries can be changed only by deleting them first and then re-entering.

(2) PARAM 1: This is used to extract a test from a data stream. It may contain a line number or character number. Set by LASET into TC(I,2) this field. Check the interface notes or review the routine.

(3) PARAM 2: This is used to extract a test from a data stream. It may contain a line number or character number set by LASET into TC(I,3) in this field. Type a whole number between 0 and 10000. Refer to the instrumentation/interface section for information about these five fields.

(4) PARAM 3: This is used to extract a test from a data stream. It may contain a line number or character number set by LASET into TC(I,4) in this field.

(6) Download Code: This is the code to send the instrument for downloading of load lists that this test is requested.

(11) Routine Storage: Pointer to the LAB DATA file (#63) and is triggered by the test name, above. Do not edit.

(31) LOAD CHEM TESTS: This field is used by the LASET routine to determine what to do with the chem test subfile. T or blank moves the data into the TC array. U moves the data into the ^TMP("LA",SJ, global. N will not move at all. Set according to needs of instrument routine.

(40) ALARM TERMINAL (Subfile): A multiple field to be filled in with the device name(s) where a warning message will print should the LSI/interface stop.

(.01) Alarm Terminal: This field contains the name/numbers of devices which will report the status of the interface. This points to the DEVICE (#3.5). Enter the device names that should be told of a LSI interface stop.

(60) MICRO CARD TYPE (Subfile): This entire subfile is at present devoted to supporting bidirectional interfacing of the Microbiology auto instrument. If you are not attempting to interface one of these types of instruments, you may ignore this entire subfile. If you are attempting to interface such an instrument, consult Microbiology Instruments Guide. There are examples available for various instruments.

(.01) Micro Card Type: Enter the Micro Card Type. Answer must be 1-4 characters in length (Instrument card type). This is a HEX code which represent the card type. OE=GRAM.

(.5) Card Name: Enter the Card Type Name e.g., Gram Neg Id Card Name. Refer to the instrumentation/interface section of the guide for information.

(7) Process Card Call: If a routine is required to process incoming data from the instrument, enter a routine name. See interface notes for routine(s) names. These fields have been added to facilitate the interfacing of microbiology instruments.

(1) Organism (Subfile): This subfield contains a list of possible identifiable organism which can be identified on or by this card. It is a multiple field and contains particulars for each organism.

(.01) Organism: Enter the name of organism which is in ETIOLOGY file (#61.2). This file will only allow organism which are either Bacterium, Fungus, or Mycobacterium identifiers.

(1) Card Code For Organism: Enter the card code for this organism. It is usually a two digit Hex code.

(2) Drug (Subfile): This subfield contains a list of drugs which Card is capable of testing and reporting.

(.001) Number: Enter the number used by the instrument to identify the drug in uploaded data stream. Enter 1-99 matching the index from the instrument.

(.01) Drug: Field 4 under the existing multiple field Drug, called display order, has been added. This is to assist Micro in displaying the drugs in the order in which they come off the instrument.

(1) Drug node: Enter the drug name which the number corresponds to in File #62.06.

(2) PARAM1: Enter a MUMPS code string needed to convert/extract data into the variable V. This field is similar to Param 1 fields in other auto instruments. The name has been changed to prevent confusion in referring to the two fields.

(3) Card code: This is the code from the card to do the lookup on. On each card it is possible to have codes represent different messages or canned comments. This subfield identifies the relationship. Enter the code, the card upload data will be contained.

(4) Display Order: Enter a number between 1-100 for display order, or 0 for file entry order.

(9) Section: Answer must be 2-30 characters in length.

(10) Bit Position: What bit (number of characters from the left) position the drug is located.

(3) Message (Subfile): For each card code, there can be an associated message to represent that code. This subfield setup that relationship.

(.001) Number: Type a whole number between 1 and 99. This field represents the internal file number for this message. This number must be unique to the file.

(.01) Code: Message code, entry must be 1-10 characters in length.

(2) Flag value: This field contains the flag value sent by the instrument with the upload data. Value if matches then include msg.

(3) Message: When the flag value is detected this message will be used. This field is similar to the LAB DESCRIPTION file and Expanded comments.

(70) INTERFACE NOTES: This word processing field contains notes on how to set up the instrument and other pertinent information on interfacing the instrument, entered by lab package developers.

(91) DOWNLOAD ENTRY: This field is used to indicate an entry point into the routine used to do the actual downloading of data to the instrument.

(92) DOWNLOAD PROTOCOL ROUTINE: This field is used to indicate the routine used to do the actual downloading of records to instrument.

(93) FILE BUILD ENTRY: This field is used to indicate the entry point into a routine that is used to reformat the worklist record for transmission and place it in the 0 nodes of the LA global.

(94) FILE BUILD ROUTINE: This field is the name of the routine which is used to reformat the worklist records for transmission.

(95) SEND TRAY/CUP LOCATION: This field will contain the default to the question, Send Tray/Cup location, used by the same bidirectional routines.

(96) QUEUE BUILD: This field contains the Default answer to Queue to build Question.

(97) MICRO INTERPRETATION CHECK: This field specifies how the data being processed should be handled.

(100) METH NAME: Pointer to the method field of this file, and will be stuffed automatically. Refers to the statistical method used by the instrument.

(101) MEAN DATA VALUE 1: These fields should contain the expected mean values of the first, second, and third results.

(102) MEAN DATA VALUE 2: A group of three results to be used in the Bull Algorithm quality control calculations.

(103) MEAN DATA VALUE 3: Example, the MCV, MCH, and MCHC values from a CBC.

(105) MICRO AUTO APPROVAL METHOD: This field selects the method to be used with this instrument during verification. This entry will allow "RPT DATE APPROVAL" prompt during verification. The default is VS (Verify Supervisor). If one wants the report to release and verified, enter VS, otherwise a supervisor must release the report before being verified and printed to the cumulative.

NOTE: The Micro Auto Approval Method field (#105) is associated with the Micro Approval Method field in the LAB REPORTS file (#64.5). Make sure the fields agree and are appropriate for your site. **This field is only used for MICROBIOLOGY AUTOMATED INSTRUMENTS.**

(106) DEFAULT AUTO MICRO TEST: This is the default Laboratory test name to be used to record workload for each organism when using the Automated Micro Instrument to verify test.

(107) SITE NOTES DATE (Subfile): Date of the note.

(.01) Site Notes Date: Date

(1) TEXT (Subfile): The actual text of the note. This is a word processing field.

(.01) Text: The actual text of the note.

Bidirectional Communications

Bidirectional communications of Laboratory instruments can be done at your site if the following items have been accomplished:

1. Version 2 EPROM chips have been installed in the LSI. These chips may be obtained from your regional ISC.
2. Version 5.1 or greater of the DHCP Automatic Lab instruments package has been installed.
3. DHCP bidirectional routines have been written for the instrument to be interfaced. These routines will include the bi-directional communication routine(s) for downloading and uploading, routine(s) to move the data from ^LA to the ^LAH globals, and may also include verification routine(s) in the case of microbiology instruments.
4. The AUTOMATED INSTRUMENT file (#62.4) has been properly defined for the instrument to be interfaced.
5. A LOAD/WORK LIST file (#68.2) has been properly defined.
6. Ability of the instrument to function in the bidirectional mode. This ability should have documentation provided by the instrument manufacturer which should include complete information on the bidirectional communications protocol and procedure, instrument setup (there may be many ways to configure an instrument), and an example of the expected download and upload data stream.

It is important to mention that there are no industry standards which define bidirectional communications. This means each manufacturer may have completely different approaches to the problem of downloading and uploading information from an instrument to and from a host CPU. Each instrument is a completely separate experience. For this chapter we have defined the term "download" as patient demographic data, specimen and test information and other necessary data required to perform and report test results sent from the host CPU to the instrument. Upload is defined as data sent from the automated instrument to the host CPU as completed test result and other information necessary for the verification and reporting of test results in the DHCP laboratory software. For example, the communication protocol KERMIT, used by Kodak in their Ektachem, is the choice of the manufacturer and may not be the choice of other instrument manufacturers.

Handshake Routines (Bi-directional)

The handshake program called by the Lab program is used to check the incoming records. The program has several responsibilities:

1. Check for the start of the data block.
2. Calculate the checksum for the data block.
3. Check for the end of the data block.
4. Compare the calculated checksum to the checksum received in the data block.
5. If the checksum is correct, the program may send an acknowledgment that it has received the data correctly if it is required, and send the next block of data to the instrument, or do nothing but return to the Lab program.
6. If the checksum is invalid, the program resets the "I" subscript entry so that the next record received will overwrite the bad record and send a negative acknowledgment to the instrument if it is required.
7. If a record is to be sent to the instrument, the appropriate number of requests for service are generated in the "Q" subscript of the ^LA global and the program returns to the Lab program for actual sending of the record(s).

Processing Routine

Each instrument has a unique single routine. The Lab program will find which routine to use from the Program field of the AUTOMATED INSTRUMENT file (#62.4) for each automated instrument that is interfaced. The processing routine also has several responsibilities:

1. Gets data from the ^LA global.
2. Determines the accession number.
3. Breaks out the raw data into individual elements.
4. Manipulates the raw data from the instrument.
5. Stores manipulated data in ^LAH(Load/Work list #, for that accession number.

Storage of data in ^LA is done in three main areas. Results data being received is stored sequentially under the ^LA(T, "I" subscript for each instrument (where T is the internal number of the AUTO INSTRUMENT file (#62.4). Download data is stored sequentially under the ^LA(T, O subscript for each instrument. An additional area under the Q subscript is used to indicate service requests made for each instrument. These service requests are stored sequentially so that the requests are processed in a first-in-first-out (FIFO) manner. An instrument requesting service for incoming records or by the download programs for outgoing records lists its request under this Q node.

The following is an example of ^LA for instrument T: (Where T = Instrument #)

^LA(T,"I")	=34	The total number of records received
^LA(T,"I",0)	=1	Number of records processed
^LA(T,"I",1)	=data	Data received from instrument T
^LA(T,"I",34)	=data	Last record of data received
^LA(T,"O")	=10	Total number of records to be sent
^LA(T,"O",0)	=1	Number of last record sent to instrument T
^LA(T,"O",1)	=data	Record to be sent to instrument T
^LA(T,"O",10)	=data	Last record to be sent
^LA("Q")	=25	Last request number for service
^LA("Q",25)	=7	Service request to LAB program from instrument on port 7 of LSI

Download Routine [LA DOWN]

This option invokes an instrument specific routine to process a load worklist for downloading to the instrument. The option will prompt you with a series of questions relating to the building of the download record. Care must be taken to ensure that only the desired accessions are built on the worklist.

The building of the download records are performed in two steps:

Step 1: All of the accessions which have tests indicated on the load worklist are collected and stored in the load worklist file, indexed by cup.

Step 2: The protocol converting process transforms the data stored at the above node into the correct format for downloading, which includes headers, checksum, and end of file marker.

It usually requires several programs to execute a bidirectional protocol, and they are namespaced accordingly.

Related Fields

With the advent of bidirectional software, several fields were added to the file. It is recommended that a new set of file attributes be generated for Version 5.1 or later versions.

LABORATORY TEST file (#60)

Field #412, called Culture ID prefix, is used to indicate to the VITEK that this is a test to be downloaded and used to indicate a multiplier factor. This is so multiple tests can be downloaded for one accession.

AUTO INSTRUMENT file (#62.4)

Field #91, called Download entry, is used to indicate an entry point (line tag) into the download protocol routine.

Field #92, called Download protocol routine, is used to indicate the routine used to do the actual downloading of data records to the auto instrument.

Field #93, called File build entry, is used to indicate the entry point into (line tag) a File Build routine.

Field #94, called File build routine, is used to enter the name of the routine which is used to reformat the load/worklist records for transmission and places the reformatted record in the O nodes of the ^LA global.

Field #95, called Send tray/cup, is used to indicate the default answer to the question SEND TRAY/CUP.

Field #96, called Queue build, is used to indicate the default answer to the question, QUEUE BUILD.

Field #4, under the existing field Micro Card multiple field Drug called display order has been added. This is to assist Micro in displaying the drugs in the order in which they come off the instrument.

Field #6, under the existing multiple field Chem tests, is where a new field called Download code has been added. This new field is used to store the character code that is used in the download to indicate the actual laboratory test to be run.

LABORATORY SITE file (#69.9)

Field #210, called Download Full Data, is used to indicate to the download routine how much data to download to the instrument. If a site answers "NO" to this field, the download routine will only download the instrument required fields. If "YES" is answered to this field, the download routine will download all possible data fields that the instrument will accept. The time taken to download each record and storage capacity of the instrument are the issues here. The smaller the download record, the less time it will take to complete the process. Check your automated instrument setup and try to send the minimum amount of data necessary to meet the auto instrument and your site requirements.

Version 2 LSI Eprom Installation

There are two methods for upgrading the LSI with the Version 2 Eprom chips.

- A. If you do not have the expertise available to change the EPROM chips, you can call your regional ISC for advice on installing the new chips.

NOTE: Some ISCs may also provide installation of the chips at the ISC. This, of course, should be arranged in advance of sending the LSI to an ISC. Each ISC will have its own policy about EPROM chip installation.

- B. If you do have the expertise available to change the chips, you can use the following procedure to do the upgrade/installation.

1. If your LSI is on-line to the system, shut down the Lab program gracefully. This is done by entering the following command in programmer mode in the UCI and on the CPU where the Lab routine is running. Be sure to do a system status to verify where the Lab routine is running and do not shut down the Lab routine if any automated instruments are still sending automated testing data.

S ^LA("STOP",x)=" where x = Instrument number (i.e., 1 for the first LSI and 11 for the second LSI, etc.)

For example: S ^LA("STOP",1)="

will stop the LAB routine for a systems first LSI.

NOTE: If your LSI is not on line, or you are planning to change the EPROMs in the backup LSI, it is very important to check out the backup/inactive LSI in the unidirectional mode first. Do this by switching LSIs and running the backup LSI and checking it out with ALL AUTOMATED INSTRUMENTS THAT HAVE BEEN INTERFACED with exactly the same four wire phone cables. This will check the functionality and wire wrapping of the backup LSI. If a particular automated instrument works with the first LSI and does not work with the second LSI, first check that the RJ11 plug is properly plugged in, then check the wire wrapping of the second LSI on the port that does not work. **** If the LSI has been sent out for repair, many times boards may be exchanged at the repair shop and your wire wrapping is altered. The best way to ensure that both LSIs are always working properly is to rotate the LSIs on a regular basis.

2. Do a system status to verify that the LAB routine has stopped. If the LAB routine has stopped, turn off the LSI.
3. Disconnect power from the LSI.
4. Disconnect the CPU line to port 1 on the LSI.
5. Remove 2 screws from the rear of the LSI where ports are connected.
6. Carefully lower the panel, remove and label the cables from the top two boards before disconnecting.

←**WARNING:** For the following steps, it is advisable to have some means of grounding yourself and the board work area to eliminate the possibility of differential ground potentials which could damage the board components or EPROM chips. Most biomedical engineering sections will have grounding equipment and anti static foam to place the LSI boards and new EPROM chips on. Adherence to the above caution will ensure a trouble-free EPROM chip installation.

7. Carefully remove the top board from the card cage and lay it on the work area with the gold edge connector on your left and the 2-ribbon connector plugs on your right.
8. Referring to figure 2-1 on page 2-2 of the General Digital GDC 2100 Data Concentrator Maintenance and Operations Manual, locate sockets XE39 and XE32 in the upper center of the board. These pages are also included in the appendix at the end of this chapter.

LSI Graphic - Processor Board

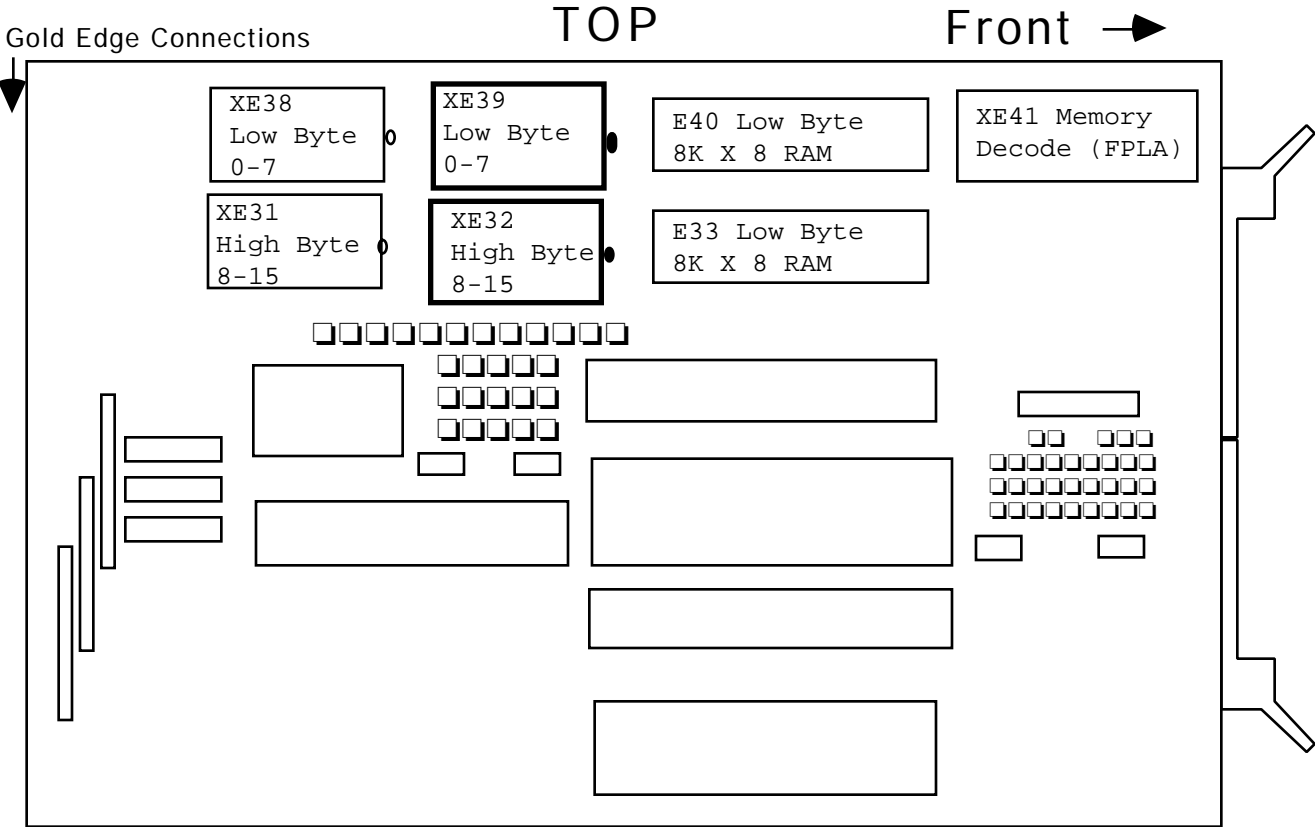

9. Orient the new chips with the chips in XE39 and XE32.

NOTE: The new EPROM chips you receive may look different from the chips that are in the LSI. The chip may have a notch in the end, a cut corner, a small dot in one corner or some other type of corner marking. This marking is used to determine which corner pin is Pin number 1 of the chip. It is critical that the new EPROM chip be installed in exactly the same orientation as the old one. This is done by locating where the pin number 1 is on the old and the new chip. To properly align PIN 1 of the chip, place the notch or the small dot pointing to the right or toward the handle.

10. The chip in XE39 is the LOW byte (bits 0-7) chip and the chip in XD32 is the HIGH byte (bits 8-15) chip and the new chips should be oriented in the same manner, ensuring that PIN 1 is inserted into the PIN 1 slot.

NOTE: It is very important to be careful when installing the new chips to know where pin 1 is, avoid damaging any of the pins and to be sure all pins are seated in the chip holder on the board. This can be accomplished by following the notes and instructions about PIN 1 and holding the chip at an angle and starting to seat all pins on one side of the chip into the socket. Using gentle pressure toward the seated side and downward, rotate the chip until the pins from the other side are seated into the socket. Then apply pressure to the center of the chip and/or to both ends and seat the new chip firmly into the socket.

11. Using a chip remover, remove chips from XE39 (LOW byte) site, observing where pin 1 is. Install the new EPROM LOW byte chip with pin 1 in the proper orientation. Remove the XD32 (HIGH byte) chip and install the new EPROM HIGH byte chip, being careful to observe where pin 1 is located.
12. Replace the board in the empty top position card cage of the LSI, making sure it is fully seated.

NOTE: The new EPROM chips check the baud rate, parity, number of data bits and number of stop bits more stringently than the Version 1 chips. Even though your automated instruments worked with the old chips, there may be configuration inconsistencies between the LSI and your automated instruments with the new EPROM chips. For this reason, while you have the LSI opened up, double check the port boards (DLV11J's) in the LSI to be sure the baud rate, number of stop bits, number of data bits and parity are EXACTLY that which the instrument(s) are transmitting. If the setting(s) are not correct, you may get no data, a mix of lower case and upper case characters, or get garbled data in the ^LA global. Parity was not checked adequately in the Version 1 chip. This has been corrected in the Version 2 chip, so if your site has problems, we suggest looking at this wire wrap first. If you have questions on wire wrapping, refer to the section in this manual. You should also have handy the interface information supplied by the AUTOMATED instrument manufacturer and double check what parameters the automated instrument is set to transmit. If there are transmission inconsistencies, change the one that is easiest for your site.

13. Double check the port boards (DLV11Js) to be sure that the baud rate, number of stop bits, number of data bits and the parity are EXACTLY that which the automated instrument is transmitting. Refer to the above note if there are inconsistencies. If you are not sure about the port numbering sequence, refer to the diagram in this chapter on LSI Interface ports.
14. Reconnect the removed cables to their proper locations.
15. Raise and replace the panel and screws removed in steps 5 and 6.

NOTE: It is now time to do some verification that the installation of the new EPROM chip has been successful. This verification should be done in a step by step mode for the best results.

16. Using a RJ11 four wire system, connect a CRT terminal to port 1 of the LSI. Additional information on wiring configuration is elsewhere in this section.
17. Set the CRT for 2400 baud, no parity, 8 data bit characters and 1 stop bit.
18. Reconnect the power to the LSI.
19. Turn on the LSI Interface.
20. After a few seconds you should see a startup message that looks something like:

```
STARTED V 2.24 XXXXXXXXX
```

If you do not see this message, go back and double check all your work to be sure everything is right, including your terminal cable pins 2 and 3.
21. When you see the STARTUP message, on the CRT, all upper case, type T00L000<RET><RET> (these are number zero, and not the letter O).
22. If you see the character A on the screen, everything is fine and you can continue to the next step. If you see nothing, double check the lines from the LSI to the terminal and return to step 20. If this does not help and you are still not able to obtain the A character on the CRT, call your ISC for help.
23. Shut off the interface.

24. Disconnect the CRT from port 1 of the LSI and reconnect the CPU line to the LSI port 1.
25. Modify the system device table for the Device Number (IO) the LSI is connected to, from 1200 to 2400 baud.
26. Use Test the Interface option [LA LAB Test] to verify that the LSI can communicate to the host CPU and the host CPU can transmit to the LSI. If the option is successful, you will get the message:

STARTED V2.24 XXXXXXXXXXXX

followed by additional line by line information as the LSI and host CPU communicate with each other. A Control C will exit the option when you are satisfied all is working OK. If you do not get the STARTED message, do a Control C and run the option again.

When you are prompted to turn off and then on the LSI, be sure the LSI is off for a full five seconds. If you still do not get the STARTED message, go back to step 24 to check your RJ11 connection and then check each additional step. If you are still unable to get the STARTED message, call your ISC for assistance.

27. Restart the LAB program using the Restart processing of instrument data option [LA JOB]. The option sometimes takes 10 to 30 seconds to start the LAB job, so be sure to not start the LAB job more than once. If the LAB job does not start, contact your System Manager/IRM Chief for help in starting the LAB job.
28. After the LAB job has been successfully started, run the Check the Interface [LA 1103] option to verify that the lab interface system is OK and ready to transmit automated instrument data.
29. If the Check the Interface report is OK, then run each automated instrument in the UNIDIRECTIONAL mode that they were running in before installing the new EPROM chips. See if you are able to verify results from each automated instrument, using the EA (Enter/Verify Data-Auto Instrument) [LRVR] option, or whatever option your site uses to verify test results from interfaced automated instruments.
30. You have now successfully completed the installation of the new EPROM chips. Please mail the old chips back to your ISC in the chip carrier the chips were sent to you in, for recycling. (Please do this quickly, since there is a limited supply of the EPROM chips.)

LSI Wire Wrapping

The following steps should be taken to reconfigure the LSI. Be sure the unit is unplugged and the area is free of static. The boards requiring reconfiguration are DLV11J DEC boards.

1. Place LSI on table with RJ11 phone jacks facing you.
2. Remove two screw which hold the RJ11 panel to the LSI.
3. Carefully lower the RJ11 panel.
4. The ribbon cable is connected to three boards. The top board is the processor and needs no adjustments. Make sure to number or mark the tags on the wire cables before you remove them from the plugs. Carefully remove the appropriate board. The middle board corresponds to 1J3 through 1J0, while the lower board corresponds to 2J3 through 2J0. The board slides out through the space created by the RJ11 panel removal. Pull gently on the two thumb tabs located on either side of the board. A gentle rocking to either side may dislodge the board easier. Place the board along side of the LSI so the four plugs remain at the front of the RJ11 panel of the LSI and so the little black chips on the board face up. Rotate the board 180 degrees so you can read the lettering on the board.
5. Inspect the board for loose wires and/or chips. On the lower left is a 3 x 9 row set of pins with tiny wires wrapped around some of the pins. It is labeled A5 at the left and 01X at the bottom. At the lower right is another set of pins labeled A6 and BXH. These pins determine the address and vector jumpers for the processor and do not require any change. At the top left and top right are 4 x 3 rows of pins. These pins configure the DLV11J board to be RS232 or RS423 EIA-compatible. These sets of pins do not need to be changed. At the top center of the board is a set of 2 x 5 row pins and one set of three pins. The factory has pins 0, 1, 2, 3 connected to pin W. The W corresponds to 1200 baud and by connecting the W to 0, 1, 2, 3, all 4 RJ11 phone ports are set for 1200 baud. The numbers correspond to the RJ11 ports, while each letter corresponds to a different baud rate (letter: U=150, T=300, V=600, W=1200, 6=4800, N=9600, K=19200, Z=38400). The wires are frequently daisy chain wire wrapped. Along the left side of the board are four sets of 3 x 4 rows of pins. The top set is labeled CH0 for the corresponding J0 RJ11 jack and its left label is EDSP. There are wire wraps or blue chips on the pins. The pins determine the other line parameters (D=data bits, S=stop bits, P=parity inhibit, E=even parity enabled).
6. Wire wrap the appropriate pins using a wire wrap tool. The tool is usually available in your BMET shop.

Example: I want to change P2 and 2J3, 2J2, and 2J1 to 2400 baud, no parity, 1 stop, and 7 data bits. I want to change 2J0 to 4800 baud, even parity, 1 stop, and 8 data bits.

Solution 1:

P2 is factory set to 1200 baud, no parity, 8 data bits, and 1 stop bit. This should not be changed. The wire wrap is on the processor board and is different from the previous discussion. It is unlikely that you will have 9 devices interfaced, and you should save this channel (P2) for last. If problems develop, you can fall back to this channel.

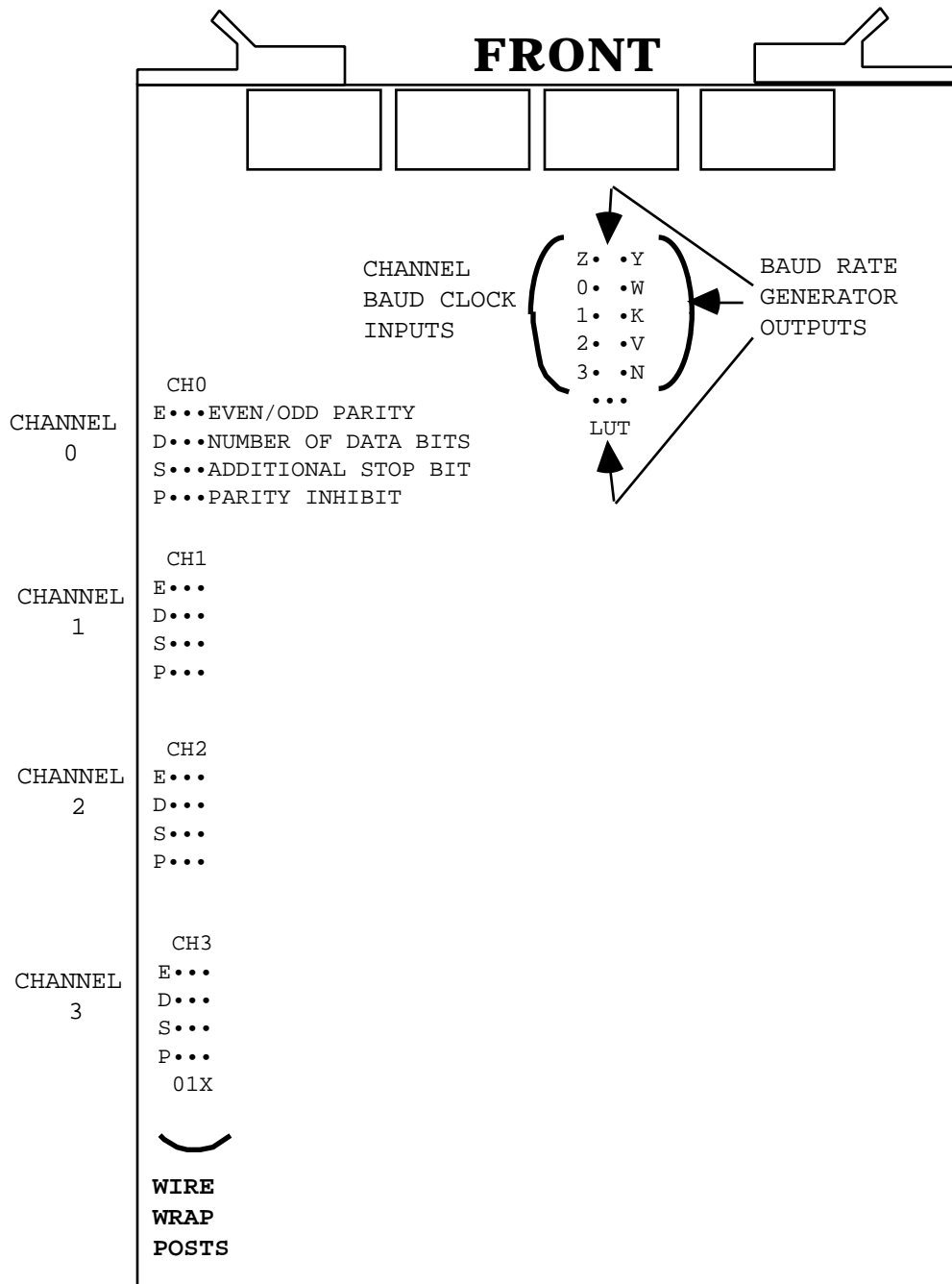

Solution 2:

To set 2J3, 2J2, 2J1, to 2400 baud, find the top center set of pins and unjumper the leads from 1, 2, 3, to W and re-jumper 1, 2, 3, to Y. Unjumper pin 0 to W and re-jumper 0 to pin L. Avoid touching other pins with un-insulated wires. To set 2J3, 2J2, 2J1, to no parity, locate the left hand 4 sets of 3 x 4 pins and verify for CH3, CH2, CH1, the P letter has the right two pins jumpered (1 and X pins). Remember, this is factory preset to no parity. The E jumper must be connected from X to 0 or 1 even if the parity bit is disabled. Verify that channel 1, 2, 3 letter E is wire-wrapped. The factory preset stop bit is one so channels 1, 2, 3, for letter S should have the left and right pins wrapped, bypassing the center 1 pin. To set channels 1, 2, 3 for, 7 data bits, remove the blue plastic clips or wire wrap from the D set of pins and wire wrap the left and right (X to 0) pins. To set J0 to even parity, wire wrap CH0 letter E center and right pins together (X to 1) and CH0 letter P left and right pins together (X to 0).

The factory has preset the CH0 to 1 stop but 8 data bits, so the S letter should have the left and right pins wrapped (X to 0) and the D letter should have the center and right pins wire wrapped.

7. Label the RJ11 outlets with the appropriate configuration.
8. A complete explanation can be found on pages 2-12 through 2-14 of Section III in the General Digital, GDC2100 Data Concentration Maintenance, and Operations Manual, November 30, 1984.

Other LSI Chip Information

Using Version 1 chips, you will notice many blank lines in the LA global. These lines usually are not blank, but have control characters which were not printable. With the advent of the Version 2 chips, all control characters have been made printable. This is done by taking each control character and generating a two character printable code, which makes it easy to see what has been received by the system. The printable code is in the following format:

~C

where ~ is a prefix notation telling you that the next character is a control character. The C is the printable form of the control character. This is generated by taking the ASCII value of the control character and adding 64 to it, giving a new value. This value is then used to get the printable character.

Example: ACK has an ASCII value of 66
 add 64 to this 64
 giving a value of 70
 The ASCII value for the letter F is 70
 Therefore an ACK would be represented as ~F

Some of the most common control codes you will see in the LA data stream are:

Example: STX(start of text)	ASCII value 2 = ~B
ETX(end of text)	ASCII value 3 = ~C
EDT(end of transmission)	ASCII value 4 = ~D
ENQ (enqueue request)	ASCII value 5 = ~E
ACK(acknowledge)	ASCII value 6 = ~F
NAK (negative acknowledgment)	ASCII value 21 = ~U

Whenever a control code is seen, the LSI changes the code into the above format and sends it with a carriage return, line feed after it. Therefore, a control code will always be either on a line by itself or the last character on the line.

The components of the LSI are well defined in the General Digital Maintenance and Operation manual that was supplied with each LSI. It would be very wise to locate one of these manuals at your Medical Center and keep it handy for reference. General Digital has gone out of business, so repair service for the LSI must be obtained by your site from a local vendor. If you can't find a local vendor, we suggest calling your ISC for information on vendors who will repair the LSI. Except for the special EPROM chips provided by the Dallas ISC, all components of the LSI are standard equipment and may be purchased from vendors on the open market. Using the General Digital Maintenance and Operation manual as a guide, the Medical Center's biomedical engineering shop could purchase all the LSI components and assemble another LSI. If this approach is taken, a Medical Center would be able to service their own LSIs and always have a spare. Any site wishing to take this route could request additional EPROMs from their ISC and buy the other components on the open market.

Wiring Diagrams and Pin Definitions for Automated Instruments

Automated Instrument Interface Specifications

TYPE OF INTERFACE: RS 232

CABLES: Two 2: twisted pairs
 Pair 1: 1 transmit signal, 1 signal ground
 Pair 2: (Optional) 1 receive signal, 1 signal ground
 Shield: (Optional)

CONNECTORS:

- A. Connector for the instrument end of cable is instrument specific. Usually a DB 25P or DB 25S connector.
- B. The Interface end of cable needs a modular phone plug to connect to a modular phone jack located on the LSI.

NOTE: Use the fact that the ground wires on the LSI are shorted together to eliminate wiring problems when wiring up instruments.

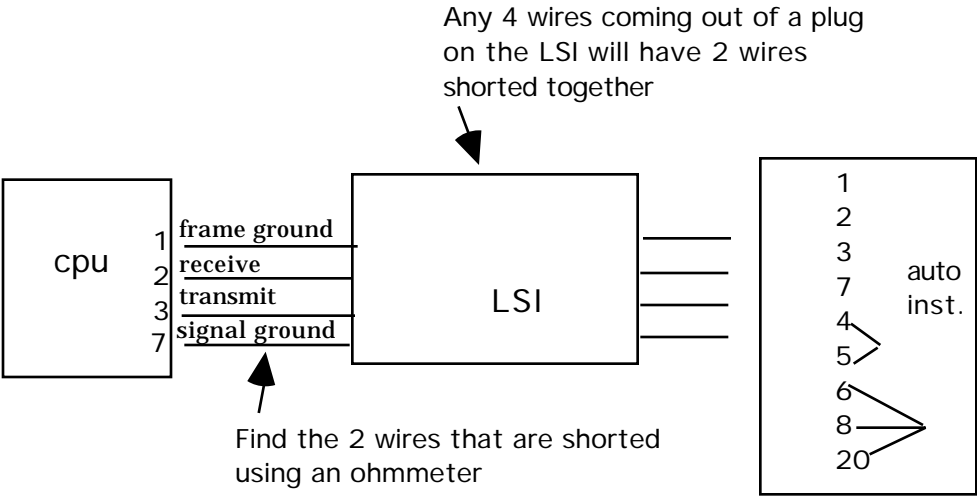

If you plug into the LSI, then check the four wires at the other end to find out which two are shorted. These are ground wires and will be connected to pins 1 and 7 (it does not matter which) on the computer port or the instrument. Now there are only two wires to worry about and they will go on 2, and 3 so if one combination does not work, try the other.

If the instrument requires jumpers, start out by shorting pins 4 to 5, and pins 6, 8, and 20 together.

For runs of any distance, you should always use four wires, two twisted pairs, properly terminated on pins 2, 3, 7, and 1.

NOTE: On the instrument side of the LSI connect pin 1 only at one end.

Automated Instruments Interface

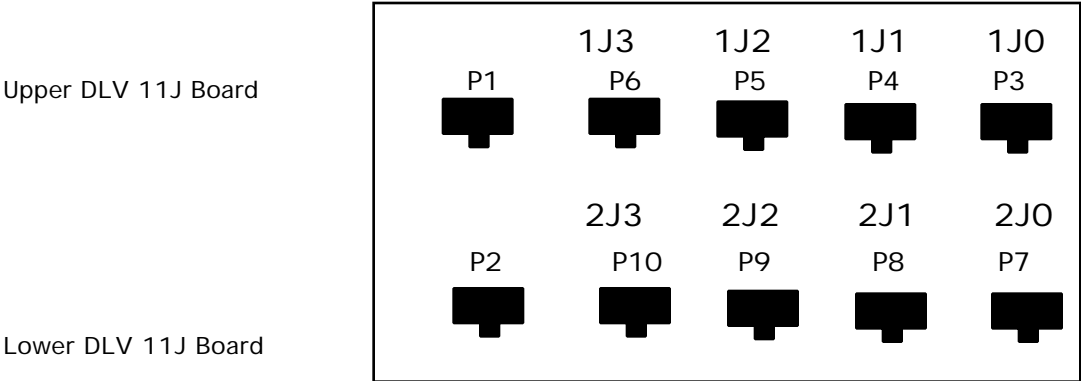

LSI CABLES

All ports have been preset to 1200 baud by the factory. P1 is only to be used for the LSI-to -Host connection. The baud rates for ports P1 and P2 are hardwired to 1200 baud. All other ports may be site-configured from 150 to 9600 baud by wire wrapping or dip switch setting selected posts on the DLV11J board(s).

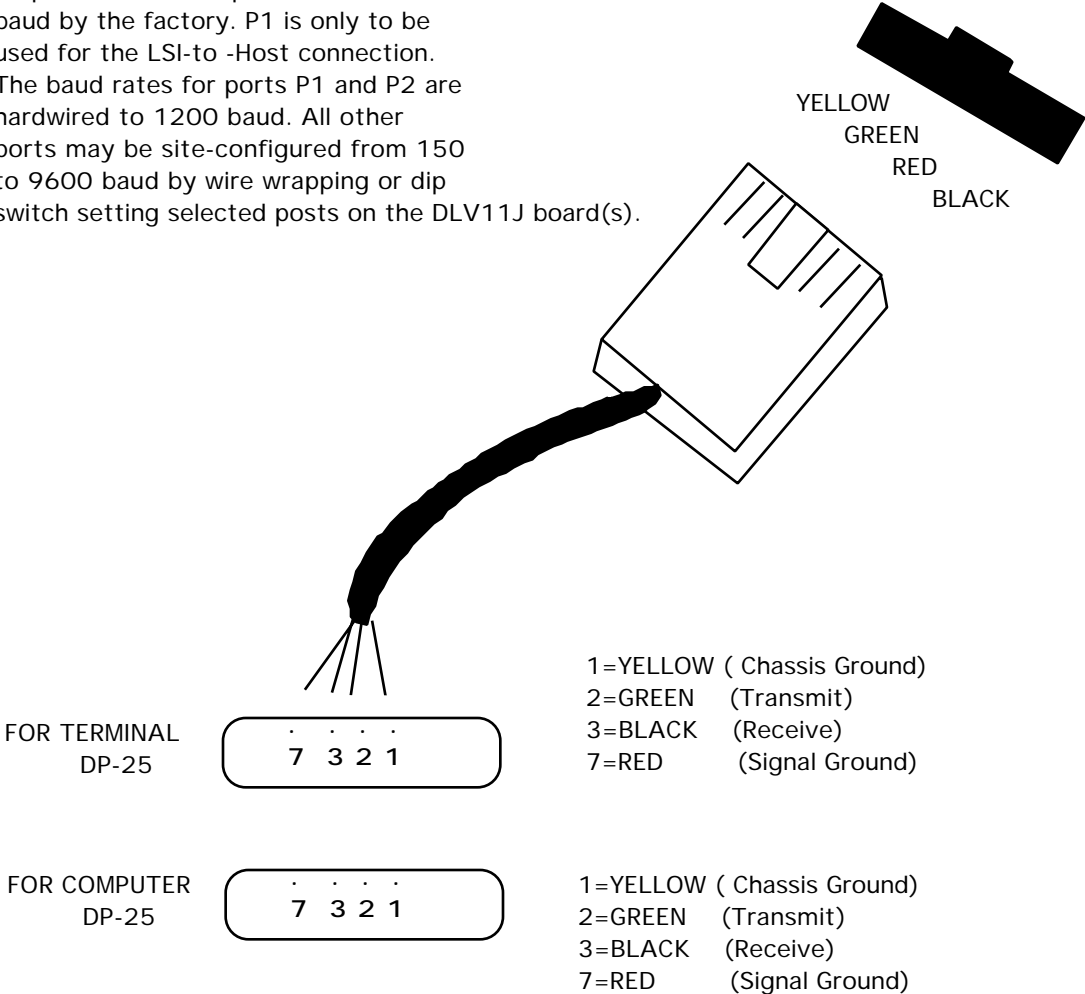

Interfacing Pin Definitions

The default configuration of the interface ports (i.e., the way they are shipped) is 1 stop bit, 8 data bits, no parity, and 1200 baud rate. The configuration of the interface and the instruments must match each other. Wire wrap connections must be changed to modify the configuration.

LSI Interface Testing

When the LSI is first turned on, the LED on the processor board will go on for 1/2 second, then off for 1 to 2 seconds, then on for 1/2 second, then off. In the time that the LED is off, the software is doing a memory test. At this time, the LED will flash at a 1 second rate, and the message STARTED V. 2.24 123456789: X is sent to the host from port 1 of the LSI. At this time a terminal can simulate the host for checking the LSI, as shown below.

```
D ^LABTEST
=>T01L001 1 1 A
<==T01L011M001      .M001,H0000
==>T00L000 A
==>T00L00  A
```

Checklist for Instrument Interface

1. Instrument must be transmitting data.
2. Correct baud Rate:
$$\text{instrument baud rate} = \text{interface instrument port baud rate}$$
$$\text{host system baud rate} = \text{interface system port baud rate}$$
3. Echo device defined in the DEVICE file.
4. LAB program routine must be running.
5. The device baud rate is correct.
6. ZTM program routine must be running (Task Manager).
7. AUTO INSTRUMENT file (#62.4) is defined correctly.
8. Input lines are wired correctly.

Instrument Interface Troubleshooting

**By Randy Frommater, Developer
Salt Lake City ISC**

- **LSI management:** To shut down the LAB program set the STOP node by entering the following:

S ^LA("STOP",N)=" " (WHERE N represents the AUTO INSTRUMENT file (#62.4) entry number for the LSI)

The LAB job will continue starting processing routines until no more data remains in ^LA global. At this time, LAB will check the STOP node and if it exists, it will kill off ^LA and shut itself down. This is the proper way to bring down the LAB job and not have partial data left in ^LA.

NOTE: This will not work if the LAB job is not actually running as happens sometimes when it shows up on system status but no processing routines get started.

- **Multiple LSI:** The procedure is the same except the LSI need to be stopped and started in a certain order.

1. Stopping LAB: shut down in reverse order LSI #3, then LSI #2, then LSI # 1.
2. Starting LAB: start in numerical order...first LSI #1, then LSI #2, etc.

Crashes and just having IRM kill the LAB job can account for incomplete data streams in ^LA which in turn may cause the processing routine to error out when the LAB job is started again. If this happens, the best thing to do is have IRM kill the ^LA(n) node and either retransmit your data or rerun it.

- **Troubleshooting** (with and without programmer access): Techs reports the Enter/verified data (auto instrument) option, EA indicated there is no data to verify. Use Lab interface [LA INTERFACE] menu and observe the system status display. Is there data in ^LA? ^LAH? If "YES" to both, use the Watch the data in ^LA global [LA WATCH] option to look at upload data. If ^LA(n, "I", 0) = less than ^LA(n, "I"), this is the last line that was processed and you should look at ^LA(n, "I", value of ^LA(n, "I", 0)) for any unusual characters. To view ^LAH global data you can do the following:

1. Version 5.2: Use the Watch the data in ^LA global [LA WATCH] option.
2. Check to see if the results reported missing are in fact in ^LAH.

- **The normal identifier node in ^LAH looks like this:**

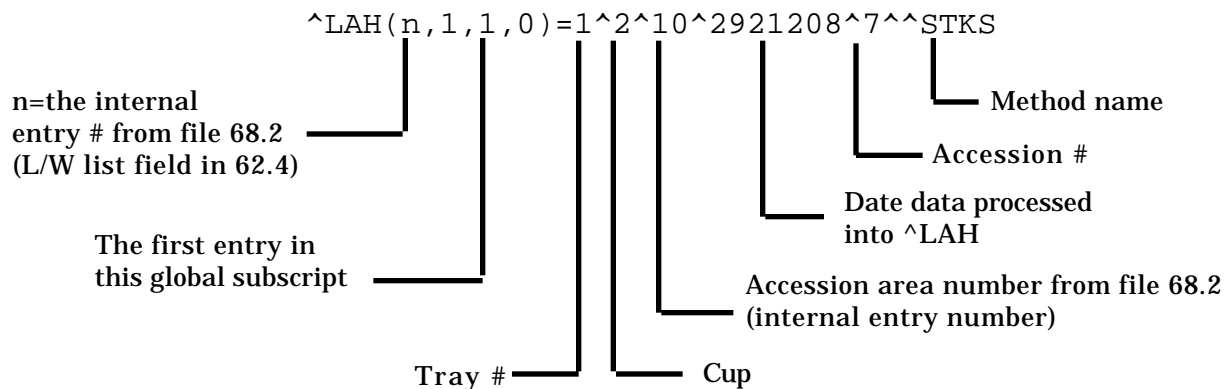

For the most part, the above data stream will be what you look for as a healthy identifier node. The most common problem is a missing date entry. The probable cause of this is that the ID or Account number transmitted did not find a match in the accession file. If you were in "EA" and entered the tray and cup as 1 & 2, the results would be displayed to you. There is an occasion where all you might see is this:

$\text{^LAH}(n, 1, 1, 0) = 1^2\text{^STKS}$

This is a healthy identifier node for an instrument set to verify by tray/cup. This is not all that common since verify by accession is the most common choice.

- **Data in ^LA? YES, ^LAH? NO:**

Again, check the "I") and "I",0) nodes in ^LA. If "I") has value and "I",0)=0 check the error log to find out what may have happened to the processing routine. (Lab Interface menu => Lab error trap listing option, or the ^LA("ERR") node). Verify that the routine entered in the AUTO INSTRUMENT file (#62.4) is correct and if there was an entry in the error log, make sure the variable LANM equals this entry. Check to see that other instruments on the same LSI are still running. If not, the Lab program has shut down. If they are, suspect a problem in the ^LA data stream causing the processing routine to quit or crash.

If the later is the case, it is time to call in IRM. Have them clear the variables from the partition leaving only the basic system variables. If ^LA("LOCK",n) is set, kill it. Set ^LA(n, "I",0)=0, zload the processing routine and start executing the code command by command writing variables as you go until you get to the point where the data stream fails the code and causes it to either ignore the data or quit.

- **Data in ^LA? NO, ^LAH? NO:**

What you are seeing here could be one of two things: **1)** the instrument has stopped transmitting (suspect either a wiring problem or instrument parameter has been reset to a default of no transmission), or **2)** the processing routine completed its task and killed off ^LA(n) and ^LA("LOCK",n). You can check number "1" by watching the ^LA global while a transmission is in progress. If you suspect number two, have IRM set ^LA(n, "I")=0, and ^LA(n, "I",0)=0. This will stop the processing routine from acting on the new data that you will now transmit and give IRM a chance to step through the code as in the procedure previously stated.

- **Illegal Number or Maximum Errors:**

The most likely cause is having the letter E as part of the value of V when it is used for setting the value of a variable in the plus form.

Example: S ID=+V. Find out who or what is adding this E to the data. Accession numbers should not contain alpha characters although some instruments allow this type of entry.

- **Variables used in auto instrument interface routines:**

TSK,T = both are used to represent the port or instrument number.
LANM = processing routine name.
ID = accession number.
IDE = instrument sequence number.
TRAY and CUP are self explanatory.
TC() = the array built when ^LASET is run.

These variables contain the information from the AUTO INSTRUMENT file (#62.4) for test name, data name location, and params 1-3:

Example: TC(I,0)=1.....First test in AI chem test field.
 TC(I,1)=TV (384,1)....Data name location (storage)
 TC(I,2)=.....Param 1 value
 TC(I,3)=.....Param 2 value
 TC(I,4)=WBC.....Param 3 value

TV() = the array built by indirection in the processing routine, used to set test values into ^LAH.

Code example: S @TEST(TEST)=+V will set the following:

where TEST = WBC and TEST("WBC")= TV(384,1) TV(384,1)=5.7
where TEST = RBC and TEST("RBC") = TV(385,1) TV(385,1)=4.32
etc.

TEST() = array that holds test name identifiers built from param
3 or TC(I,4)

Example: TEST("WBC") = TV(384,1)

IN = the value of the data node being processed (^LA(n,"I",X)

Y (1) = the value of IN. This may be a single entry or an array. It is used
for parsing out data.

V = used for passing a value to the subroutine NUM and then setting a
variable upon returning.

LAGEN =- contains the executable code determined by the ENTRY for
LAGEN ROUTINE entry in the AUTO INSTRUMENT file (#62.4).

LWL = the internal entry number for the load/worklist used by this
instrument. It is set by taking the 4th piece of the auto instruments zero
node from AUTO INSTRUMENT file (#62.4).

Example: ^LAB(62.4,2,0)=Coulter STKS^^LACOLTSE^7^^LOG^ID^^^STKS

without programmer access you can use FileMan Inquiry option and use
number instead of standard output when inquiring on the load/worklist
entry.

• **Local AUTO INSTRUMENT files:**

The most important trouble shooting tool you can have is to keep a file on each
instrument interfaced. This file should contain the following information captured
when the interface is up and working well:

- 1) samples of the LA and LAH data streams,
- 2) copy of the routine used,
- 3) captured print of the AUTO INSTRUMENT file (#62.4) and LOAD/WORKLIST
file (#68.2) entries,
- 4) any pertinent data related to the wiring of the interface,
- 5) instrument parameter settings.

- **Direct connect instruments:**

Direct connecting of instruments should be reserved for those instances where going through the LSI just will not work. This happens sometimes when two or more major instruments are on the same LSI. The traffic during transmission slows the verification process down to unacceptable levels. If the instrument in question does not have a direct connect routine as part of the released package there are three alternatives available to you:

- 1) place one instrument on its own LSI,
- 2) get a local programmer to modify a copy of the LAPORTXX routine to work with this instrument,
- 3) submit an official request to the Auto Instrument ARG for approval of development. Some sites have expressed the desire to bypass the LSI completely and direct connect ALL instruments. This causes much overhead on the system because every instrument would have to have a background job associated with it which increases the chances for problem by how ever many background jobs you have running. The LSI is old, it is simple, but it works.

LAPORTX X Routine

The LAPORTXX routine is provided to be copied and modified when developing a new direct connect routine. It is meant to be a starting point only, and cannot be ran as is. Once modified, this routine will act like the LAB job in that it will watch a single port (not from the LSI) and store the data transmitted into a specified ^LA(XX port. The important criteria here is that you choose a port outside the range of existing LSI(s). Remember each LSI has a range of ten starting with 1-10, 11-20, 21-30, and so on. If you have two LSIs in use on your system select a direct port of 33 for example.

LAPX Routine

The LAPX routine is provided to be copied and modified when developing a new unidirectional routine. Just like the LAPORTXX routine, this routine is meant to be a starting point only and cannot be used without modification.

Instrument Routines

The following is a list of instruments that have been written and tested. Most of these are unidirectional routines. Where there is a bidirectional routine for the instrument, this is so indicated.

NOTE: All the routines that began with a "LAI" have been renamed to prevent any accidental confusion with INIT routines.

Status code

5.1 Released with Version 5.1

#nn Patch number (Version 5.1)

UD Under active development - either at the Dallas ISC or in cooperation with a local site initiative at an official test site

I Inactive (a site may have it interfaced but it is not officially supported)

5.2 To be released with Version 5.2

Bi/Uni code

B Bidirectional

U Unidirectional

Name	Routine(s)	Bi/Un	Status
ABL3 RADIOMETER	LAABL3	U	5.1
ABL4 RADIOMETER	LAABL3	U	5.1
ABL300 RADIOMETER	LAABL3	U	5.1
ABL330 RADIOMETER		U	I
ABL500 BLOODGAS	LAABL500	U	#117
ACA3	LAACA	B	5.1
ACA4	LAACA4	B	5.1
ACA5	LAACA4	B	5.1
ACCUDATA GTS		U	UD
ALTAIRE	LAALTA	U	5.1
APPRAISE, BECKMAN		U	I
ARRAY, BECKMAN		U	I
ASTRA (4,6,8/8E, IDEAL, LINKED)	LAASTRA	U	5.1
ATLAS	LACLT20P	U	#113
AXSYM, ABBOTT		U/B	UD
AUTOSCAN 4	LAMSA	U	5.1
BIOVATION KEYPAD (URINALYSIS)	LABIOU	U	5.1
BIOVATION KEYPAD (HEMATOLOGY)	LABIOH	U	5.1
BMD 8700 (printer port)	LABMD87P	U	5.1
CELLDYNE 1600		U	I
CELLDYNE 3000		U	I
CENTRIFICHEM 600	LACCHEM6	U	5.1
CHEM 1, TECHNICON	LACHEM1	U	5.1
CHEM 1, TECHNICON		B	UD
CLINITEK 200	LACLT200	U	5.1
CLINITEK 200 W/ DMS	LACTDMS	U	5.1
CLINITEK 200+	LACLT20P	U	#113
CLINITEK 2000	LACLNTEK	U	5.1
CLINITEK 5500	LACL5500	U	5.1
CLINTEK FORM PRINTER	LACLNTE	U	5.1

Instrumentation and Interfacing

COAGAMATE		U	I
COAGAMATE X2	LACOAGX2	U	5.1
COAG XC+		U	I
COAG RA4		U	I
COBAS BIO	LACBIO	U	5.1
COBAS FARA	LACFARA	U	5.1
COBAS FARA BI		B	I
COBAS FARA II	LAFARA2	U	5.2
COBAS MIRA	LACMIRA	U	5.1
COBAS MIRA S	LACMIRAS	U	5.1
COBRA/PACKARD		U	I
COMP-U-DIFF, MODULUS	LAMODH	U	5.1
CORNING ACS 180		U	I
CORNING 178	LAC178	U	5.1
CORNING 178 THRU HP	LAC178H	U	5.1
CORNING 278 LS1		U	I
CORNING 278 LS2		U	I
CORNING 288		U	I
COULTER 770	LAS550	U	5.1
COULTER JR+5	LACOLT5	U	5.1
COULTER JT	LACOLT5	U	5.1
COULTER JT3	LACOLT5	U	5.1
COULTER JT3 (running EO#,BA#)	LACOLT6	U	5.1
COULTER MAXIM	LACOLTES	U	#11
COULTER S EDMAC 2400 INTERFACE	LACOLT24	U	5.1
COULTER S PLUS	LACOLT1	U	5.1
COULTER S PLUS 2	LACOLT2	U	5.1
COULTER S w/COURT II	LASCT	U	5.1
COULTER S SR	LACOLT5	U	5.1
COULTER S+ JR	LACOLT5	U	5.1
COULTER S+4	LACOLT5	U	5.1
COULTER S+5	LACOLT5	U	5.1
COULTER S+6	LACOLT5	U	5.1
COULTER S+6, DT W/DH INT	LACOLT6	U	5.1
COULTER SR+2 W/QC MODULE	LACOLT3	U	5.1
COULTER STKR-S	LACOLT5	U	5.1
COULTER STKS 1E	LACOLTSE	U	#11
COULTER Sr.	LACOLT	U	5.1
COULTER S550	LAS550	U	5.1
COULTER S560	LAS550	U	5.1
COULTER S770	LAS550	U	5.1
COULTER S790	LAS790	U	5.1
COULTER S880	LAS790	U	5.1
COULTER T660	LACOLT5	U	5.1
CX3, BECKMAN	LASTRA	U	5.1
CX4, BECKMAN	LABCX4B	U	5.1
CX4, BECKMAN	LABCX4B	B	5.1
	LABCX4D		
	LABCX4H		
	LABCX4XX		
CX5, BECKMAN	LABCX4B	U	5.1
CX5, BECKMAN	LABCX4B	B	5.1
	LABCX4D		
	LABCX4H		
	LABCX4XX		
CX7, BECKMAN		U	UD
CX7, BECKMAN		B	I
DACOS, COULTER	LADACOS	U	5.1

Instrumentation and Interfacing

DEMAND	LADMND	U	5.1
DIMENSION, DUPONT	LAACA4	U	5.1
DIMENSION DIRECT CON, DUPONT	LAAIMPXX	B	5.1
	LADIMD		
	LADIMPI		
DIMENSION H-6000, DUPONT	LAH6K	U	5.1
E4A, BECKMAN	LAE4A	U	5.1
EDC, HELENA	LAHEDC	B	I
	LAHEDCD		
EKTACHEM 400	LAEKT4	U	5.1
EKTACHEM 700	LAEKT7	U	5.1
EKTACHEM 700 (printer port)	LAEKT7P	U	5.1
EKTACHEM 700 BI	LAEKT7B	B	5.1
	LAEKT7B1		
	LAEKT7B2		
	LAEKT7B3		
	LAEKT7D		
	LAKERM2		
	LAKERM3		
EKTACHEM 700 DIR.CON.		B	I
EKTACHEM 700 (updated software)		B	I
ELECTRA 900, MLA	LAMLA1KC	U	5.2
ELECTRA 1000, MLA	LAMLA1KC	U	5.2
ELT 1500	LAELT8D	U	5.1
ELT8, DS	LAELT	U	5.1
ELT8 with 3 cell diff	LAELT8D	U	5.1
EPX BI DIRECT CON	LAEPXD, LAEPXPX	B	5.2
ERA, PHOTON	LAERA	U	5.1
EXECUTIVE, ABBOTT	LAEXEC	U	5.1
H1, TECHNICON	LAH1	U	5.1
H3, TECHNICON		U	I
H6000, TECHNICON	LAH6K	U	5.1
HEMALOG D, TECHNICON	LAHLOG	U	5.1
HEMATRAK 360	LAH480	U	5.1
HEMATRAK 480	LAH480	U	5.1
HEMATRAK 590 GEOMETRIC	LAH480	U	5.1
HEMATRAK 590 W/ DIFFS	LAHTRK	U	5.1
HITACHI 704	LAH705	U	5.1
HITACHI 705	LAH705	U	5.1
HITACHI 717	LAH717U	U	5.1
HITACHI 717 THRU CCA	LAHTCCA	U	5.1
HITACHI 717 BI		B	I
HITACHI 717 W/JT		B	UD
HITACHI 736 W/ JT1000	LAHT1K	B/U	5.1
	LAHT1KD		
HITACHI 737	LAH737	U	5.1
HITACHI 747	LAH747	U	5.1
HITACHI 747	LAH747	B	#99
HITACHI 911		B	UD
IL 1303	LAL13	U	5.1
IL 1306	LAL1306	U	5.1
IL 1312	LAL1312	U	5.1
IL 508	LAL508	U	5.1
IL 943	LAL943	U	5.1
IL CELLECT 8E	LACEL8E	U	5.1
IL BGE		U	I
IL BG3	LALBG3	U	5.2
IMX, ABBOTT	LAAIMX	U	#118

Instrumentation and Interfacing

INTERLINK, BECKMAN	LABITKU	U	5.1
IRIS	LAYRIS	U	5.1
KDA, AMERICAN MONITOR	LAKDA	U	5.1
KEYBOARD DIFF	LAKDIFF	U	5.1
	LAKDIFF1		
	LAKDIFF2		
	LAKDIFF3		
KEYBOARD URINE	LAKUR	U	5.1
	LAKUR1		
KOAGULAB 40-A	LAKOAG40	U	5.1
MICROSCAN	LAMSA	U	5.1
MICROSCAN	LAMSA1	B	5.1
	LAMILL		
	LAMSBLD		
	LAMSD		
	LAMSP		
	LAMSPAN		
MLA 700	LAMLA7	U	5.1
MLA 900	LAMLA1K	U	#98
MLA 900C	LAMLA1K	U	#98
MLA 1000C	LAMLA1K	U	#98
MONARCH 2000, IL	LAMONARK	U	5.1
MULTISTAT 3	LAMSTAT	U	5.1
NE 8000 (same as SYSMEX 8000)	LASYS8K	U	5.1
	LASYSMEX		
NOVA 4+4	LANOVA	U	5.1
NOVA 11+11	LANOVA	U	5.1
NOVA STAT PROFILE	LANOVST	U	5.1
PARALLEL, AMERICAN MONITOR	LAPARA	U	5.1
PARALLEL (printer port)	LAPARAP	U	5.1
PARAMAX, BAXTER	LAPMAX	U	5.1
PARAMAX, BAXTER	LAPMAX	B	5.1
	LAPMAXD		
PARAMAX 700ZX		B	I
PERSPECTIVE	LAPER	U	5.1
PERSPECTIVE	LAPER	B	5.1
	LAPERD		
RA4, ORGANON	LACOARA4	U	5.2
RA-1000, TECHNICON	LARA1K	U	5.1
RA-2000, TECHNICON	LARA2K	U	5.1
RA2X, TECHNICON	LARA2K	U	5.1
RA2XT, TECHNICON	LARA2K	U	5.1
RAPIMAT II, BEHRING	LARAPMT	U	5.1
RAPIMAT II BI, BEHRING		B	I
REP, HELENA		U	I
SMA II/C	LASMA2C	U	5.1
SMA II/Gen 2	LASMA2	U	5.1
SMA 60	LASMA12	U	5.1
SMA 18/60-VICKERS SP120 INTERFACE	LASP120	U	5.1
SMAC I	LASMACA	U	5.1
SMAC I	LASMACA4	B	5.1
	LASMACA		
	LATECH1		
	LATECHHS		
	LATECHD		
SPECTRUM, ABBOTT	LASPEC	U	5.1
SPECTRUM		B	I
STRATUS, BAXTER		U	I

SYSMEX 8000	LASYS8K	U	5.1
SYSMEX E-5000	LASYSMEX	U	5.1
SYSMEX E2000	LASYSMEX	U	5.1
SYSMEX K1000	LASYSMEX	U	5.1
TDX, ABBOTT	LATDX	U	5.1
TDX (with specimen ID) V10.1	LATDX1	U	5.1
TDX, PACKARD	LATDX	U	5.1
TOA	LATOA	U	5.1
UR-O-COMP, MODULUS	LAMODU	U	5.1
UR-O-COMP, MODULUS VERT FORM	LAMODUT	U	5.1
VITEK (Version 5.0 or less)	LAMIVTK	B	5.1
	LAMIVTKC		
	LAMIVTKD		
	LAMIVTKU		
	LAMIV11		
	LAMIV12		
	LAMIV10		
	LAMIV00		
	LAMIVT5		
	LAMIVT6		
	LAMIVTE6		
	LAMIVTK6		
	LAMIAUT7		
	LAMIAUT8		
	LAMICRA		
VITEK (Version 5.0 or more)	LAMIVTK	B	5.2
	LAMIVTKC		
	LAMIVTKD		
	LAMIV11		
	LAMIV12		
	LAMIV10		
	LAMIV00		
	LAMIAUT7		
	LAMIAUT8		
	LAMICRA		
	LAMIVT5		
	LAMIVT6		
	LAMIVTE6		
	LAMIVTK6		

^LA & ^LAH Global Descriptions

Justification and Descriptions of Non VA FileMan Compatible Globals

The ^LA and ^LAH globals are used by the automated instrument routines in the lab package to capture the raw data produced by lab instruments and then to process the data into a usable format.

The data in the ^LA and ^LAH globals is transient, but is different from ^TMP(\$J) globals in that its existence transcends a single job and needs to be translated.

Description of ^LA Global

```

^LA(0)=RAW AUTO INSTRUMENT DATA           ^62.45P
^LA(INSTRUMENT #, "I")                     = Pointer to last data node added
^LA(INSTRUMENT #,"I",0)                    = Pointer to last data node processed
^LA(INSTRUMENT #,"I",IFN)                  = Raw data
^LA(INSTRUMENT #,"0")                      = Count of nodes queued for sending
^LA(INSTRUMENT #,"0",0)                    = Count of nodes sent
^LA(INSTRUMENT #,"O",IFN)                  = Raw data
^LA(INSTRUMENT #,"Q")                      = Count (used in queuing)
^LA("LOCK",IFN) =                          "" (Running flag to only allow one routine
                                           to run)
^LA("STOP",IFN) =                          "" (If set, tells routine to stop
                                           running)
^LA("Q") =                                  Count (Used in queuing)
^LA("Q",IFN) =                              =(Tells LAB routine which instruments have
                                           data)
^LA("TP",0) =                               Pointer to last data node added (If set,
                                           the LAB routine stores a copy of all
                                           instrument data under this node; can be
                                           used in trouble-shooting an instrument)
^LA("TP",IFN) =                             Instrument #^Raw data...

```

Description of ^LAH Global

```

^LAH(0) =                                   PROCESSED LOAD/WORK LIST DATA^68.3P^
^LAH(LOADLIST #) =                         Count of entries
^LAH(LOADLIST #,1,IFN,0)                   = Tray^Cup^Accession area
                                           #^Date^Accession #^^Method
^LAH(LOADLIST #,1,IFN,TEST FLD #)          = Result^^Flags
^LAH(LOADLIST #,1,"B",TRAY;CUP,IFN)        = "" (Cross-reference for tray/cup
^LAH(LOADLIST #,1,"C",ACCESSION #,IFN)     = "" (Cross-reference for Accession #)
^LAH(LOADLIST #,1,"E",IDE #,IFN)           = "" (Cross-reference for IDE #)

```

The LAB DATA file (#63) is strictly a storage file for all the test results (data), comments, etc. The field names are descriptive of the contents in that they are the names of the tests, procedures, antibiotics, etc. The content of the field is the data value.

VAX Example of Device Setup for the Laboratory System Interface (LSI) Excerpted from the VAX Cookbook - May 1989, pp 4-52-53

* WIRING DIAGRAM:

LSI	DECSERVER
2 -----	2
3 -----	3
7 -----	7

* DECSERVER PORT SETUP:

From the DECserver local> prompt:

(where xx would be a DECserver port #, and DHCP is the name of the dedicated service.)

```
Local> set port xx access remote modem disabled name LSI speed 2400**
Local> save port xx
```

Using Terminal Server Configurator (TSC) (see Chapter 5.E Terminal Server Software for more info on TSC)

```
TSC> define port xx access remote modem disabled name LSI speed 2400**
```

If Port 8 on a DECserver were SET and DEFINED in this manner, the DECserver SHOW PORT command would result in the following:

```
Local> show port 8
```

```
Port 8:
Character size :           8           Input Speed:           2400**
Flow Control:           xon           Output Speed:           2400**
Parity:                 none          Modem Control:   disabled

Access:                 Remote        Local Switch:           none
Backward Switch:       none          Name:                   LSI
Break:                 Disabled      Sessions Limit:         4
Forward Switch:        none          Type:                   ANSI

Preferred/Dedicated Service: none

Authorized/Current Groups:      0

Enabled Characteristics:

Message Codes, Verification
```

NOTE: For Version 1 EPROM chips, the speed is 1200 baud. For Version 2 EPROM (bidirectional) chips, the speed is 2400 baud. Check with the Lab Application Coordinator to determine if the Version 2 chips have been installed.

*** VMS SETUP :**

Under \$MGR LATCP a port must CREATED and SET. See example of LTLOAD.COM in Chapter 5.E Terminal Server Software. In the following example with LTAxxx, xxx would be replaced by the actual name assigned to the port at the site. DSVnn would be replaced by the actual DECserver name. 'port_name' would be replaced by the physical name of the port (e.g. LC-1-6) or other site-specific format. It is IMPORTANT that 'port_name' be the same as defined on the DECserver and as created by LATCP.

LTLOAD.COM

```
Ex. $MCR LATCP
    CREATE PORT LTAxxx: /NOLOG
    SET PORT LTAxxx: /APPLICATION/NOLOG/NOQUEUE/NODE-DSVnn/NAME-port_name
```

The system manager must run the following VMS command procedure to create the Automatic Log-in File database, SYSALF.DAT:

```
$ @SYS$MANAGER:ALFMAINT.COM
```

Once created, the DSM utility ^ALF is used to tie terminals to a VMS username.

*** DSM SETUP:**

The LSI port on the DECserver should be set up to bypass the VMS username prompt. A DSM utility ^ALF is used, as follows. In this example, DECserver DSV22, port LC-1-8 is the port the LSI is connected to that is tied to username DHCP:

```
>D ^ALF
```

Edit or List the VMS Automatic Log-in file: SYS\$SYSTEM:SYSALF.DAT

Do you want to add or modify (A),delete (D), or list (L) records? **A**
Add record, or modify an existing record.

```
Terminal (ddcu)? DSV22/LC-1-8
User Name? DHCP
Terminal DSV22/LC-1-8 user DHCP record added
```

SYS\$SYSTEM:SYSALF.DAT has been updated.

Example of How to Define the Echo Device for the "System" Auto Instrument

(The device entered is the IO port on the host CPU that will be connected to P1 of the LSI.)

Select Systems Manager Menu Option: **F** VA FileMan

VA FileMan Version 17.32

Select VA FileMan Option: **Enter** or Edit File Entries

INPUT TO WHAT FILE: **AUTO INSTRUMENT**

EDIT WHICH FIELD: ALL// **<RET>**

Select AUTO INSTRUMENT NAME: **SYSTEM**

NAME: SYSTEM// **<RET>**

ECHO DEVICE: 70// **<RET>**

PROGRAM: LAB// **<RET>**

LOAD/WORK LIST: **^**

Select AUTO INSTRUMENT NAME: **<RET>**

Select VA FileMan Option: **<RET>**

Bar Code Readers (Blood Bank Module)

The Blood Bank Module uses bar code technology for the input of data relating to the units of blood/blood components - i.e., the blood component (a five digit code), the donor unit ID number (an 8-11 characters number) and the donor ABO/Rh. While the data can be entered manually, it requires at least 50% more time and obviously introduces the possibility of clerical errors. In facilities where the number of units in inventory is relatively large, repetitive entry of groups of numbers or letters of 8-11 characters can result in a significant error rate. In facilities where donors are drawn, the savings in time are even more dramatic, in that labeling of the units after processing is decreased from two technologists to one technologist with a bar code reader.

There are two types of bar code readers available, the pen/wand type and the laser. The ONLY requirements for the bar code reader to be used in the Blood Bank Module are as follows:

- 1) ability to read Codabar, since this is used for all donor labels in accordance with the Uniform Blood Labeling Act.
- 2) ability to be connected in line between the CRT and the CPU via cables.
- 3) ability to set the unit to read stop codes.

To determine which type of reader is appropriate for your facility, and to evaluate the various readers on the market, you should consider the following:

- Overall numbers of blood/blood components being handled in a given period of time, equating to the likelihood of typographical errors.
- Number of rejections, i.e., the ease with which the reading is attempted before the data is accepted, since this will have a major effect on time savings.
- The condition of the units being scanned; i.e., are most of the units red blood cells whose labels are in good shape, even though not a flat surface? OR are many of the units of Fresh Frozen Plasma and/or Cryoprecipitate, since this requires reading through cellophane covering on the box, around curves, through moisture, etc.?
- The ease of handling the reader. Wand/pens are much easier to handle because you can still use your hands for something else, whereas with the laser gun model, you must keep setting the laser down to enter the expiration dates, etc. unless it is also bar coded.

Example of Bar Code Reader set up

Symbol Technologies Laser scan 7000II Hand Held Laser Scanner with the Symbol link LL340 Controller box. (Tampa, Florida is using this technology)

All settings are set up by scanning the proper bar code in the instruction booklet. Use the following settings:

CODABAR ONLY	
NOTIS EDITING	ENABLED
DECODE UPC/EAN SUPPLEMENTAL	ENABLED
UPC-E PREAMBLE	NONE
UPC-A PREAMBLE	NONE
BAUD	9600
CHECK PARITY OF RECEIVED CHARACTERS	DISABLED
TRANSMISSION DIRECTION	TALK & H'SHAKE SEC ONLY
STOP BIT SELECT	1 STOP BIT

NOTE: This example is to show you what sort of setting you will see. The Laboratory package does not advocate using this particular brand.

Bar Code Labels (Accession Labels)

Version 5.2 includes the ability to print bar codes labels for specified accession areas. One bar code label, with the number part of the accession barcoded, along with the regular accession label can be printed. This ability is broken down by accession areas. It will allow a laboratory to turn on or off the printing of bar codes for a specific accession area.

At present, the routine is written only for the default label type which is a 15/16" x 3.5" label using the LRLABEL routine and the VAF 10-1392 label using the LRLABEL5 routine. Two printers have been defined to allow the printing of bar codes. They are the OTC 800 dot-matrix printer and the Intermec heat sensitive printer.

Implementation for the OTC 800 Printer

The following files must be edited for bar code printing:

1. ACCESSION file (#68)

There is a new field (#5) called BAR CODE PRINT. For printing of bar codes for a specified area, this field needs to be set to "YES". To turn off the bar codes for an area, delete the "YES".

2. TERMINAL TYPE file (#3.2)

A terminal type needs to be created for an OTC printer that has the Bar Code ON field (#60) and BAR CODE OFF field (#61) defined as follows:

BAR CODE ON: *27,"[4;3;0;;;]",*27,"[3t"

BAR CODE OFF: *27,"[0t"

Within the BAR CODE ON, the numbers between the [] define the format of the bar code. In some circumstances these could be changed, but realize the LRLABEL routine will need to be modified to accommodate the changes (i.e., changing the height of the bar code or printing the eye readable bar code).

The following format is used:

[P1;P2;P3;P4;P5;P6;P7;P8]

P1 specifies the type of bar code to print

- 0 Interleaved 2 of 5
- 4 Code 39 (default value)
- 5 EAN-8
- 6 EAN-13
- 9 Codabar a/a start and stop character a
- 10 Codabar b/b start and stop character b
- 11 Codabar c/c start and stop character c
- 12 Codabar d/d start and stop character d
- 13 UPC - A
- 14 UPC - E

P2 is the height adjustment. The height is adjustable from 1/12 inch to 10 inches in 1/12-inch increments. $P2=n$, where height = $(n * 1/12)$ ". The valid range of n is 1 to 120. $P2=3$ gives a barcode 1/4" high (equivalent to 2 lines). Any barcode larger than this will require a label greater than 15/16" or routine modification.

P3 specifies a readable line which is printed below the bar code.

O - Do not print human readable line

1 - Print human readable line

Parameters P4 through P8 should not be specified. These have to do with the width of the bars and spaces in the bar code symbol.

A suggested name for your newly created Terminal type is P-OTC (LAB BAR CODES).

3. DEVICE file (#3.5)

In the field Subtype (#3), enter in the newly created OTC (bar code) terminal type for your OTC label printer.

4. LABORATORY SITE file (#69.9)

In the field LABEL TYPE (#302), either leave it empty to use the default routine (LRLABEL) or if you had to modify LRLABEL enter in your modified routine LRLABEL4.

Label Example:

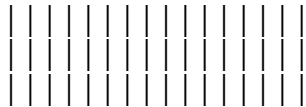
HE 0123 100 NAME,PATIENT 1234  CBC,DIFF

Implementation for Intermecc 8646 Printer

Printer setup

There are three banks of program (DIP) switches in the back panel of the Intermecc 8646 printer. Check and set them up as follows:

Top DIP switch bank: 1 to 5 OFF

Middle DIP switch bank: 1 ON, 2 and 3 OFF, 4 and 5 ON, 6 and 7 OFF

Bottom DIP switch bank: 1 and 2 OFF, 3 and 4 ON, 5 OFF, 6 ON, 7 and 8 OFF

The settings specify these parameters for the printer:

1. Character set = USA
2. Batch = disable
3. Self-trip mode = disable
4. Baud = 9600
5. Parity = space
6. Stop bit = one
7. Label stock = regular
8. Control mode = Computer
9. Protocol command = user designed/interfaced
10. Print direction/Format rotation = breach
11. Right margin override = disable
12. Bar width = 10 millimeter

Label size used: 1 by 3 inch (Intermecc Part No. 049114)

Files setup

The following files must be edited for bar code printing:

1. ACCESSION file (#68)

Set field (#5) Bar Code Print to "YES" for printing bar codes for a specified area. To turn off the bar codes, delete the "YES".

2. TERMINAL TYPE file (#3.2)

P-Other

3. DEVICE file (#3.5)

In the Subtype field (#3), enter the newly created Intermec (bar code) terminal type for your Intermec label printer.

Example:

```

NAME: BARCODE PRT                               $I: _LTA 109:
VOLUME SET (CPU): DEV                          SIGN-ON: NO
KEY OPERATOR: FRANK & TUAN                    NEAREST PHONE: 270
FORM FEED: #                                  MARGIN WIDTH: 132
BACK SPACE: $C(8)                             PAGE LENGTH:
MNEMONIC: INTERMEC
SUBTYPE:P-OTHER                                TYPE: TERMINAL
# OF ATTEMPT: 5                                LOCK-OUT TIME:5
TIME READ (#OF SEC.): 300

```

4. LABORATORY SITE file (#69.9)

In the Label Type field (#302), either leave it empty to use the default routine LRLABEL6 or if you have to modify LRLABEL6, enter your modified routine LRLABEL4.

One of the functions of the LRLABEL6 routine is to specify and to down load the format of the bar codes. For more information on the setting of the format, consult the Intermec 8640 Series Thermal Transfer Printer Manual.

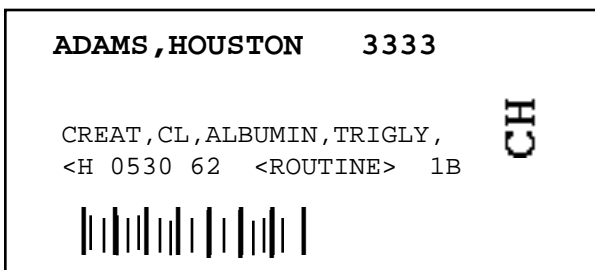

MicroScan Interface

Implementation

AutoSCAN 4 and AutoSCAN W/A

Read volumes 1 and 2 of the MicroScan[©] Mainframe Interface documentation thoroughly before proceeding.

1. System Wiring

The MicroScan AutoSCAN 4 and the AutoSCAN W/A are wired identically to the LSI for either unidirectional or bidirectional transmission. A 9-pin female connector links a communication port on the MicroScan to the LSI. Use comm port #2 for the AutoSCAN 4 and comm port #3 for the W/A.

MicroScan	RJ11 Block	LSI
3	-----	2-----2
2	-----	3-----3
5	-----	7-----7
4	-----	20-----1

a. The MicroScan is wired to an RJ11 block.

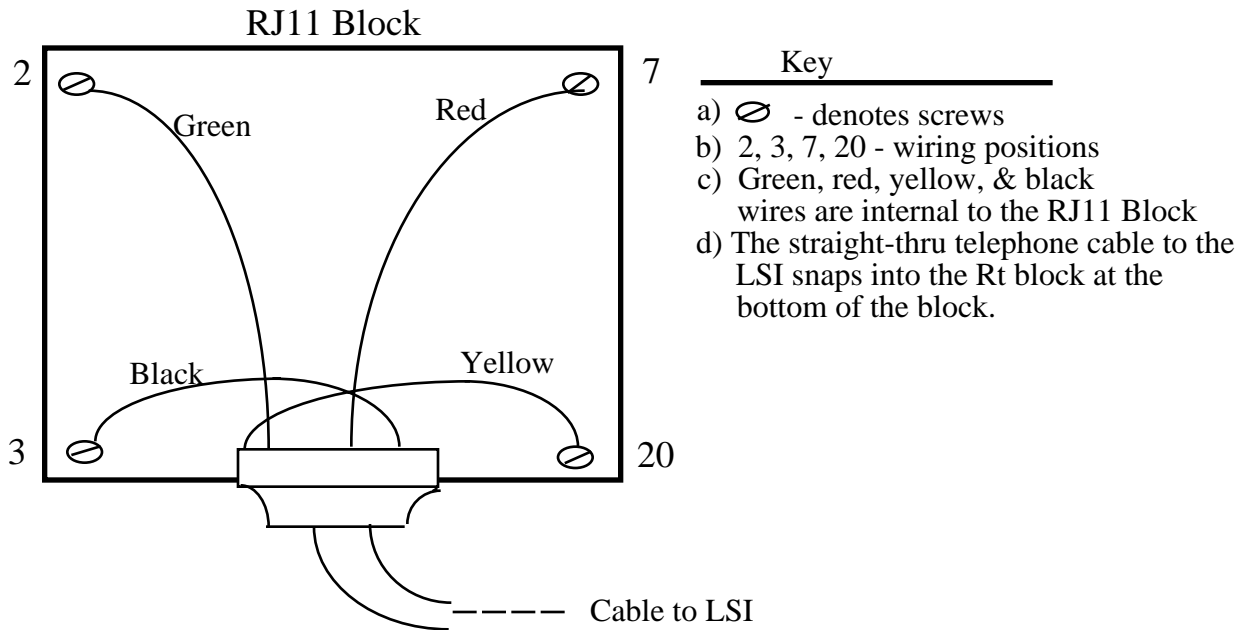

b. A straight thru telephone wire connects the RJ11 block to the LSI.

NOTE: No jumping is necessary.

2. Software Requirements

- a. MicroScan: Two Way DMS Interface Version 18.0 or higher
- b. Host: DHCP Laboratory Version 5.0 or higher

3. Interface Setup

The Interface customization files are found by selecting option #8, optional programs, from the MicroScan DMS main menu. You must select the appropriate interface program from the optional program menu to have the interface main menu displayed.

INTERFACE MAIN MENU

1. Interface Customization
2. Request Specimens from the Mainframe (Two-Way)
3. Select/Transmit Specimens to Mainframe
4. Log on New Dataset
5. Transmit/Request DMS Customizable information
6. Interface log file and Maintenance
7. Backup/Restore Interface Customization & Log File
8. Process WalkAway Specimens (V. 19.02)

MicroScan Mainframe Interface Version 19.02 Software

The Interface Customization Menu option will display the communication parameters and formats menu. The DMS computer is configured and the date format established through this menu.

NOTE: All references to DMS files refers to the MicroScan computer files not DHCP files.

INTERFACE CUSTOMIZATION MENU

1. Communication Parameters
2. Custom Data Fields Formats
3. Suppress/Customize Data Field Transmission
4. Cross-Reference Table
5. Protocol Character Definitions
6. Device Maintenance
7. Print Interface Customization (not discussed)
8. Customize WalkAway Specimen Processing

#1 COMMUNICATION PARAMETERS MENU

Device Name/Type: **LABSYSTEM** - VA SYSTEM

1. Baud Rate: **1200** (bps)
2. Word Length: **8** (bits)
3. # Of Stop Bits: **1**
4. Parity: **None**
5. Protocol: **XON**
6. Serial Port #: **Comm-#**
7. Timeout Delay: **20** (secs)
8. Checksum Type: **SUM-ASCII**
9. Null Field OK: **Yes**
10. Field Delimiter: **124 ACSII (|)**
11. String Delimiter: **0 ASCII (^ @)**
12. Delimit Character Fields: **No**
13. Hospital/Lab ID: **None**
14. Use Modem Commands: **No**
15. Phone Number: **<RET>**
16. Modify Modem Commands

#2 CUSTOM DATA FIELD FORMATS MENU

Device Name: **LABSYSTEM**

1. Specimen Number Type: **Normal**
2. Date/Time Format: **YYMMDD|HHMMSS**
3. Organism Name Format: **Abbreviated**
4. Single Therapy Reporting: **NO**
5. Sort Transmission Selections: **Specimen Number**
6. Combine Panel Transmit Method: **1**
7. Suppress MICs for Breakpoint Panels: **No**
8. Transmit Data In Long Patient Report Format: **Yes**
9. Transmit QC Data: **No**

Remember field #5 always sort by Specimen Number, not by Patient ID.

#3 SUPPRESS/CUSTOMIZE DATA FIELDS TRANSMISSION

- | | |
|------------------------------|--------------------------|
| 1. Patient Name | 13. Comment Records |
| 2. Physician Name | 14. Panel Names |
| 3. Ward Names | 15. Organism Names |
| 4. Source Names | 16. Long Drug Names |
| 5. Comment Text | 17. Patient Records |
| 6. Service Names | 18. Specimen Records |
| 7. Institution Name | 19. Isolate Records |
| 8. Free Text Records | 20. End Records |
| 9. Additional Drugs | 21. Biotype Number |
| 10. MicroScan Interpretation | 22. Header Records |
| 11. MicroScan Dosages | 23. Drug/Therapy Records |
| 12. NCCLS Interpretation | 24. Technician Names |

Select those options (1-24) that you wish to change. Options that are highlighted will be suppressed from transmission.

NOTE: Do not suppress #17, Patient Records.

#4 CROSS-REFERENCE TABLES MENU

NOTE: It is the site decision to set up cross-reference tables. You can set up a cross-reference tables for (a) ward mnemonics and (b) source mnemonics. The ward mnemonics associates every hospital location abbreviation in the DHCP HOSPITAL LOCATION file (#44) with the DMS CUSTOMIZATION file for ward locations. This is only needed if the site wants data stored differently from the downloaded ward abbreviation or site/specimens.

Instrumentation and Interfacing

1. Cross-reference Status: Enable, Key length = 5
2. Select/Suppress Data Fields
3. Edit Tables
4. Print Tables
5. Rebuild Tables
6. Set Maximum Field Length

NOTE: EXCEPTION, if a site/specimen has an alternate screen define in the ANTIMICROBIAL SUSCEPTIBILITY file (#62.06), the cross-reference table for SOURCE mnemonics must be defined to upload the internal entry number for that source:

MicroScan Code

1. Enter MicroScan code for specified site/specimen (example: URI)

Mainframe Equivalent Code

Enter the internal entry number from the topography file for that site/specimen (ex. 71 for urine)

#5 PROTOCOL CHARACTER DEFINITONS MENU

1.	<STX>	- -	2
2.	<EXT>	- -	3
3.	<EOT>	- -	4
4.	<CR>	- -	13
5.	<LF>	- -	13
6.	<XON>	- -	17
7.	<XOFF>	- -	19
8.	<ACK>	- -	6
9.	<NAK>	- -	21
10.	<ENQ>	- -	5
11.	<Prefix	- -	0
12.	<Suffix> 1	- -	0
13.	<Suffix> 2	- -	0
14.	<Suffix> 3	- -	0

#6 DEVICE MAINTENANCE MENU

1. Create a New Device
2. Log on to New Device
3. Edit Current Device Attributes
4. Delete a Device

Option 3 DEVICE ATTRIBUTES MENU

1. Device Name: **LABSYSTEM** (free text entry)
2. Device Type: **VA System**
3. Auto-Monitor: **No**
4. Auto-Transmit Time: **Disabled**
5. Auto-Transmit Format: **Test Date**
All Results
6. Auto-Request Time: **Disabled**
7. Auto-Request Format: **Test Date**
All Results
8. Number of search Days for Auto-select Data: **1**

(Types for #2: 1=LIS, 2=MicroScan system, 3=PharmLink and 4=VA/SAIC)

#8 CUSTOMIZE WALKAWAY SPECIMEN PROCESSING MENU

WALKAWAY SPECIMEN PROCESS LIST OPTIONS SUB-MENU

1. WalkAway Selection Enabled for: **All Isolates**
2. Sort Process List by: **Transmission order**
3. Suppress Oxidase Prompting: **Yes**
4. Suppress Indole Prompting: **No**
5. Default to Non-Hemolytic Reaction: **No**
6. Auto-Process Complete Isolates: **No**

NOTE: Above is site/configurable.

4. MicroScan File Setup

a. The DMS ward table listing file includes the most common ward/clinic locations used by the microbiology department of the VAMC.

Example:

1. 1 AG
2. 2 A1
3. 3 A2

- 34 B1 MEDICAL CLINICS
- 35 B2 ALCOHOLIC CLINIC
- etc

NOTE: A cross-reference table can be set up under the interface customization menu to correlate the MicroScan DMS file with the DHCP HOSPITAL LOCATION file (#44).

b. The source table listing file includes the names of all site/specimens or sources encountered by the microbiology dept.

NOTE: The source called URINE must be DESIGNATED as urine to DMS.

Example:

```
1. 1 NOSE/SINUS
2. 2 THROAT/MOUTH
3. 3 SPUTUM
34 99 NOT SPECIFIED
Press RETURN to continue or '^' to exit:
```

NOTE: A cross-reference table can be set up under the interface customization menu to correlate this DMS file with the DHCP TOPOGRAPHY FIELD file (#61).

c. The ORGANISM file on the MicroScan contains all the organisms identified by the MicroScan.

NOTE: All these organisms must be accounted for by DHCP in the ETIOLOGY file (#61.2) and AUTO INSTRUMENT file (#62.4).

d. The selected panel list displays those MIC panels selected by the microbiology department to be analyzed by either the autoSCAN 4 or the autoSCAN W/A.

5. DHCP Laboratory Files

a. ANTIMICROBIAL SUSCEPTIBILITY file (#62.06)

- 1) Use the autoSCAN 4 and autoSCAN W/A documentation to get a list of all drugs reported by MicroScan.
- 2) Refer to the Microbiology Implementation section for the procedure of adding new drugs to the DHCP and add any drug not already in File #62.06.
- 3) Reindex the following indices in File #62.06 AD,AJ,AO,AI, and AS.
- 4) D ^LAMSBLD to build the MicroScan MIC x-reference in File #62.06
- 5) Manually enter the MIC values (dilution ratios) for trimeth/sulfa, amox/k clavulanate, and ticar/k clavulanate in File #62.06.

b. LABORATORY DATA file (#63)

- 1) New drug entries must be added to the LABORATORY DATA file (#63).
- 2) Follow the procedure in the Laboratory Technical Manual for adding these new drugs to File #63.

c. ETIOLOGY FIELD file (#61.2)

- 1) Get a list of all organisms which the AutoSCAN 4 and the W/A will report.
- 2) Follow the procedure described in the Lab Implementation Guide for adding these organisms.

d. LABORATORY SITE file (#69.9)

- 1) A new field called DOWNLOAD FULL DATA must be filled in. Answer "NO" to this field.
- 2) The Micro report format is site-specific. The choices are:

I INTERPRETATION ONLY
R RESULTS ONLY
B BOTH INTERPRETATION AND RESULT

No entry defaults to interpretation only.

e. LOAD/WORK LIST file (#68.2)

- 1) Create separate load/worklists for the AutoSCAN 4 and/or the W/A. Tests listed on the worklist are site-specific.

2) AutoSCAN 4 worklist:

```
Name: BR-MICROSCAN(AUTOSCAN 4) Type: SEQUENCE/BATCH
CUPS PER TRAY: 0 FULL TRAY ONLY: NO
EXPAND PANELS ON PRINT:NO VERIFY BY: ACCESSION
SUPPRESS SEQUENCE #: NO INCLUDE UNCOLLECTED ACCESS.:NO
RUN OR TRAY NUMBER: 1 DATE: DATE
TECH: NAME ACCESSION AREA:BMICROBIOLOGY
LAST TRAY: 1 LAST CUP:0
BUILDING IN PROGRESS: NO
PROFILE: AUTOSCAN 4 ACCESSION AREA: BMICROBIOLOGY
TEST: CULTURE & SENSITIVITY BUILD NAME ONLY: NO
TEST: BLOOD CULTURE BUILD NAME ONLY: NO
TEST: FUNGUS CULTURE BUILD NAME ONLY: NO
TEST: RO/MRSA BUILD NAME ONLY: NO
TEST: LEGIONELLA CULTURE BUILD NAME ONLY: NO
TRAY #: 1
```

3) Walk/Away worklist: (Same as autoSCAN[©] 4 worklist)

f. AUTO INSTRUMENT file (#62.4)

- 1) Certain fields are site specific, such as Name, Loadlist, and Micro Auto Approval.
- 2) Be sure only one entry exists for each instrument in the AUTO INSTRUMENT file (#62.4).
- 3) The entry name, load/work list, accession area and program parameters will be instrument specific. The routine, LAMSA, was ZSAVED as ZLAMSA to be used as the program for one of the autoSCAN.
- 4) A representation of the AutoSCAN 4 entry in the AUTO INSTRUMENT file (#62.4) follows: (Same for MicroScan)

```
NUMBER: 16 NAME:BR-3-AUTOSCAN
PROGRAM: LAMSA
LOAD/WORK LIST:BR-MICROSCAN
ENTRY FOR LAGEN ROUTINE: Accession cross-reference
CROSS LNKD BY: +IDE METHOD: AUTOSCAN 4
DEFAULT ACCESSION AREA: BMICROBIOLOGY
OVERLAY DATA: YES
HANDSHAKE RESPONSE: D ^LAMSP
NEW DATA: D NEW^LASET
RESTART: D RESTART^LASET
```

NOTES:

1. There is only (1) micro card type and card name for the AutoSCAN.
2. Each organism in the ETIOLOGY file (#61.2), which is identified by the DMS AutoSCAN, must be correlated to the DMS internal number for that organism (card code).

```

MICRO CARD TYPE: GEN          CARD NAME: GENERAL CARD
ORGANISM:ESCHERICHIA COLI CARD CODE FOR ORGANISM: 1
ORGANISM:ESCHERICHIA COLI LYS- ORN-   CARD CODE FOR ORGANISM: 51
ORGANISM:ESCHERICHIA COLI CARD CODE FOR ORGANISM: 851
ORGANISM:ESCHERICHIA FERGUSONII      CARD CODE FOR ORGANISM: 803
      ...                      ...
      ...                      ...
ORGANISM:SPOROBOLMYCES SALMONICOLOR   CARD CODE FOR ORGANISM: 512

```

Each antibiotic in File #62.06 must be correlated with the autoSCAN abbreviation for that antibiotic (card code).

Example:

```

NUMBER: 1          DRUG: AMIKACIN
DRUG NODE: 2.0016   CARD CODE: Ak
NUMBER: 2          DRUG: AMOX/K CLAV'ATE
DRUG NODE: 2.00525021 CARD CODE: Aug
NUMBER: 3          DRUG: AMPICILLIN
DRUG NODE: 2.0012   CARD CODE: Am
NUMBER: 62         DRUG: VANCOMYCIN
DRUG NODE: 2.0006   CARD CODE: Va
FILE BUILD ROUTINE: LAMSD
MICRO INTERPRETATION STYLE: INSTRUMENT INTERPRETATION ONLY
(Choices are:)

F CHECK ANTIMICROBIAL FILE INTERPRETATION ONLY
I CHECK INSTRUMENT INTERPRETATION ONLY
B CHECK BOTH FILE AND INSTRUMENT INTERPRETATION OVERWRITE WITH FILE

```

g. TOPOGRAPHY FIELD file (#61)

- 1) The topography abbreviation is downloaded to DMS and null entries should be no problem.
- 2) Using DMS mnemonics as abbreviations for the TOPOGRAPHY FIELD file (#61) is site specific.
- 3) Get a listing from the microbiology department of the most commonly seen site/specimens.

h. COLLECTION SAMPLE file (#62)

- 1) Using DMS mnemonics as synonyms for COLLECTION SAMPLE file (#62) entries is site-specific.
- 2) Compare the DMS SOURCE file printout with a printout from the COLLECTION SAMPLE file (#62).
- 3) Ensure that there are equivalent entries in both files.

The Upload

1. The AutoSCAN 4 and the AutoSCAN W/A are not set to automatically upload their data to the mainframe.
2. Enter the Interface Main Menu and choose option #3, Select/Transmit specimens to mainframe.

INTERFACE MAIN MENU

1. Interface Customization
2. Request Specimens form the Mainframe (Two-Way)
3. Select/Transmit Specimens to Mainframe
4. Log on New Dataset
5. Transmit/Request DMS Customizable Information
6. Interface log file and Maintenance
7. Backup/Restore Interface Customization & Log File
8. Process Walk Away Specimens

3. The interface range of data selection menu is displayed:

1. Select specimens by range
2. Select by range of dates collected
3. Select by range of dates tested
4. Select by range of patient ID numbers
5. Select all information in dataset
6. Quick-Select for today's tests
7. Retransmit Quick-Select
8. Select individual specimen numbers

Enter Selection or ESCape to exit: <RET>
Press RETURN to continue or '^' to exit:

4. Choose option #8, Select individual specimen numbers. The microbiology department uses this option because they can retransmit the data and also select individual isolate data for a given specimen number to be uploaded to DHCP. Refer to the MicroScan mainframe interface operation manual for specific instructions. The following is an example of possible selections:

Select Individual Specimen/Isolate Combinations:

- Enter specimen number, ESCape to continue: <specimen number>
- Enter isolate number, return for ALL, ESCape to continue: <isolate #>
- Enter isolate number, return for ALL, ESCape to continue: <enter the next isolate number or ESCape>
- Enter the specimen number, ESCape to continue: <enter next specimen number or ESCape>

5. The Interface Data Option Menu is now displayed:

INTERFACE DATA OPTION MENU

1. Review Selected Data
2. Send data currently selected to mainframe
3. Suppress individual specimen/isolates
4. Print Selected Data

Enter number or ESCape to exit: <RET>

6. First review the selected data (option #1) and then send the selected data to the mainframe (option #2).

7. You will be prompted to press return when ready to transmit or ESCape to exit.

SENDING DATA TO MAINFRAME

Patient ID #:
Specimen #:
Isolate #:

Records left to transmit:

Press RETURN to continue or '^' to exit:<RET>

Press ESCape to Abort transmission

NOTE: Once the RETURN key is pressed, transmission begins. As the warning shows, you stop the transmission by pressing the ESCAPE key.

8. Any error encountered during upload will be recorded in the MicroScan transmission log.

9. The upload data is initially stored in ^LA(AI#,"I",#). The data is processed from ^LA to ^LAH. Once the data is in ^LAH it is available to be verified.

10. You can verify the MicroScan data using the Verify micro auto data option.

The Download

Downloading is moving data from DHCP to the automated instrument. This includes accession number, patient name, ID, ward location, provider, site /specimen, panel number, and isolate number.

The download can be subdivided into four activities:

1. Unloading the existing load/worklist
 2. Clearing the instrument/worklist data
 3. Building the MicroScan worklist
 4. Downloading the MicroScan worklist to the instrument
1. Unload the existing load/worklist is done with the Unload Load/worklist option. This takes ALL accessions off the list, leaving it blank.
 2. Clearing the load/worklist is done using the Clear Instrument/worklist data option. This option removes ALL data (verified and unverified) from the ^LAH global. Make sure all data has been unloaded and verified before using this option.
 3. The MicroScan worklist is built using the MicroScan Load Worklist (Build) option. The Microbiology department personnel must correlate the microbiology accession number with the DMS panel number for all accessions to be properly downloaded. The following tray/panel names are examples:

Panel number	Panel name
11	HNID
17	Neg Combo 7
32	Rapid Anaerobe ID
33	Rapid Yeast ID

Example of building a load/worklist for downloading:

```
Select Automated Microbiology Menu Option: MicroScan Load Worklist build
Select LOAD/WORK LIST NAME: MICROSCAN (name of worklist)
Select only from the MICROBIOLOGY accession area
Select Accession: MI
  Accession Date: TODAY//94
  Number part of Accession: 3000
LAST,FIRST ###-##-####
What test(s) to add?
1 CULTURE & SENSITIVITY
Enter Choice(s): 1
Enter Choice(s): <RET>
Select TEST or PANEL NUMBER: 1// 17
  ISOLATE: 1// <RET>
Select TEST or PANEL NUMBER: "17" ; (if same panel, put in " ")
  ISOLATE: 1// 2
Select TEST or PANEL NUMBER: 32
  ISOLATE: 1// 3
```

4. The Download Procedure

- a. The MicroScan interface files must be open to receive the download from DHCP. Ensure that the interface main menu is displayed on the MicroScan CRT screen before initiating the download.
- b. The download is accomplished using the Download Auto Micro Worklist option.

```
Select Automated Microbiology Menu Option: Download Auto Micro Worklist
Select AUTO INSTRUMENT NAME: MICROSCAN (or AI number) Working on the
download file for instrument MICROSCAN from the LOAD list MICROSCAN
from the LOAD list BR-MICROSCAN(AUTOSCAN4) or (WR-MICROSCAN(W/A))
Starting Tray number: 1// <RET>
Starting SEQUENCE number: <RET>
Send TRAY/CUP locations? NO//<RET> (this default is controlled by Field #95
in the AUTO INSTRUMENT file (#62.4))
QUEUE WORK? NO// <RET> (this default is controlled by Field #96 in the AUTO
INSTRUMENT file (#62.4))
```

```
DONE.      Data should start moving now
```

You can monitor the transfer of information from DHCP to the MicroScan via the LSI by using the LA WATCH option. The download data is stored in ^LA(AI#,"0",#). The LA WATCH option indicates the total number of records to be processed and the rate at which the records are being processed.

- c. The MicroScan indicates when it is receiving data from the mainframe. The patient's ID number, the specimen number and the isolate number will be displayed on the CRT as the data is being received.

```
Receiving data from mainframe. Please Wait.
Processing:                PAT ID#:
SPECIMEN #:
ISOLATE #:
```

After all the data has been transmitted from DHCP to MicroScan, the MicroScan interface screen will return to the main menu.

- d. An error message will be displayed on the MicroScan side if there were any download transmission error(s). Review the transmission log. You will get error messages if the mnemonics for Wards, Physicians, or Services are missing from the DMS customized files. These errors do not seem to cause any problems.
- e. The MicroScan will automatically tag the downloaded isolates and will assign MicroScan panel ID numbers to all downloaded isolates. You will observe a warning message on the MicroScan CRT reporting the isolates were downloaded. You can not proceed until you have entered in asked for information about the isolate. Once the information has been entered, bar code labels and worksheets can be generated.

VITEK Interface

Auto Instruments are an integral part of the Laboratory package. The VITEK is an automated instrument used in microbiology for micro organism identification and antibiotic measurements. This guide provides all of the instructions for setting up and using this instrument within the microbiology module of the Laboratory package. Step by step installation instructions, diagrams, option descriptions, troubleshooting suggestions, file setup, lists of card types, and examples of VITEK printouts are shown.

Each element of how to set up and use the interface with the VITEK is described in this manual in step-by-step procedures. On-line displays are shown. Examples of possible user responses are listed, following the on-line displays.

VITEK Interface Instructions

I. System wiring

A. VITEK system.

The VITEK system wiring is the same for both unidirectional and bidirectional. The following is a cable diagram for connecting the VITEK to an LSI.

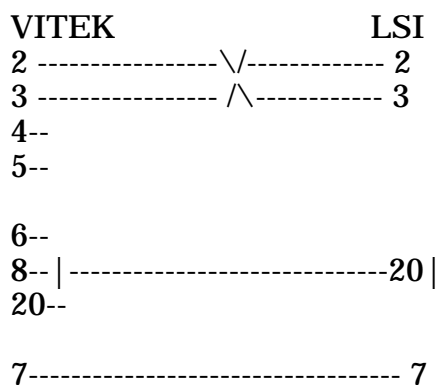

B. LSI

The VITEK will run unidirectional with the old Version 1 EPROMS in the LSI.

If you are going to run the VITEK in a bidirectional mode, you will have to install the Version 2 EPROMS before bidirectional capabilities will work. Refer to the section in this chapter about bidirectional interfacing and Version 2 EPROMS.

II. Software Requirements

- A. VITEK Unidirectional: AMS R06.1 or later bidirectional:
BCI Version 02.3 or later.
- B. Host: DHCP Laboratory Version 5.0 or later.

III. Interface Setup

- A. Unidirectional: At the VITEK system prompt run the program `cisend` and set the parameters as follows:

```
>cisend
```

The following menu will display:

```
REQUEST COMPUTER INTERFACE
      TRANSMISSION
```

- 1) TRANSMIT BY SLOT OR TRAY
- 2) TRANSMIT BY AMS ID
- 5) RETRANSMIT ALL NAKS
- 6) TRANSMIT TEST PATTERN
- 7) UTILITIES
- Q) QUIT

Choose option 7) UTILITIES

Select each of these options and respond to the prompts as shown in the example:

```
COMPUTER INTERFACE UTILITIES
```

- 1) Turn Computer Interface ON/OFF:
- 2) Set rety wait
- 3) Set number of seconds for ACK wait
- 4) Set number of NACKS before auto disable
- 5) Set STX/ETX protocol
- 6) Set Serial port characteristics
- 7) Set Display data option
- 8) Enable/Disable AMS Computer Interface
- Q) Quit

Responses will be:

COMPUTER INTERFACE UTILITIES

1. Turn Computer Interface ON/OFF: **ON**
2. SET RETRY WAIT: **10**
3. Set number of seconds for ACK wait: **10**
4. NACKS BEFORE AUTO DISABLE: **0** (defeated)
5. STX/ETX PROTOCOL: **"SSS"/**
6. HOST PROTOCOL CHARACTERISTICS: **?**
 - 1200 BAUD
 - NO PARITY
 - 8 BIT/CHAR
 - 2 STOP BITS
 - XON wait 10
 - CHAR DELAY 0
7. DISPLAY DATA OPTIONS: **ON**
8. AMS COMPUTER INTERFACE: **ENABLE**

B. Bidirectional: At the VITEK system prompt run the program bciutil and set the parameters as follows:

```
>bciutil
```

The following menu is displayed:

```
BIDIRECTIONAL COMPUTER INTERFACE  
RESULTS TRANSMISSION
```

- 1) Transmit Results by Slot or Tray
- 2) Transmit Results by AMS ID
- 3) Retransmit all NAKs
- 4) Utilities
- q) Quit

NOTE: The following menu displays are before Pre 3.1 BCI Software installation.

Select option 4) Utilities

The following menu will appear:

```
BIDIRECTIONAL COMPUTER INTERFACE  
UTILITIES (VERSION XX.X)  
1) Delete Negative Exams  
2) Status and Exception Logs Menu  
3) Transmit Test Pattern  
4) Set Serial Port Characteristics  
5) Set interface Characteristics  
6) Display data on screen  
7) Set Field Characteristics  
8) Transmit Back in Service  
9) Results (Upload) Options  
*) Special options  
q) Quit
```

Select option 4) Set Serial Port Characteristics

This menu will appear with defaults. Following the directions displayed on the screen, make changes where necessary to match values shown here:

SERIAL PORT CHARACTERISTICS

```
Number of Ports: 1
Baud Rate: 1200
Parity: None
Character Size: 8
Stop Bits: 2
Startup Message: Disable
```

Once you have finished here, return to the previous menu.

Select option 5) Set interface Characteristics

The following menu will appear with defaults. Following the directions displayed on the screen, make changes where necessary to match the values shown here. This menu is used to set up the interface.

BI-DIRECTIONAL COMPUTER INTERFACE CHARACTERISTICS

```
1. BI-DIRECTIONAL INTERFACE (UPLOAD) IS: ENABLED
2. BI-DIRECTIONAL INTERFACE (DOWNLOAD) IS: ENABLED
3. DOWNLOAD PORT: /dev/tty1
4. UPLOAD PORT: /dev/tty1
5. TIMEOUTS (seconds):
    CHECKSUM <ACK>: 60 HOST RESPONSE: 60
    XON/Xoff: 10
6. RETRY LIMITS:
    CHECKSUM ERROR: 3 <ENQ>: 3
7. RETRY INTERVALS (seconds):
    CHECKSUM ERROR: 10 <ENQ>: 10
8. DELAYS (Seconds):
    LAST MASTER: 10 INTERRECORD: 2 INTERMESSAGE: 10
9. END OF RECORD FORMATS:
    STX: DISABLED ETX: DISABLED ENQ: DISABLED
    RS: ENABLED GS: ENABLED EOT: DISABLED
10. TOTAL NUMBER OF FAILED MESSAGES ALLOWED: 3
11. FIELD TERMINATION CHARACTER(S): :
12. SEPARATOR CHARACTERS: DATE: TIME: <RET>
13. DUPLICATE DEMOGRAPHICS UPDATE: ENABLED
    STARTUP MESSAGE: DISABLED DUPLICATE UPDATE: ENABLED
```

Use the following VITEK command to make a printout of the configuration:

```
imp>p bciep
```

It is also recommended that each site perform a backup of the new BCI configuration to a floppy/tape.

C. Cautions

1. If, during an upload session, the VITEK does not receive an acknowledgment from DHCP within the 10 second time wait limit, the VITEK will retransmit the record. This will be evident by looking at the LA global and observing that the record is in duplicate. If this occurs, go to the VITEK system console and type the command:

```
>/etc/hostcts off
```

This should eliminate the duplicate sending of records.

2. If, during transmission, the VITEK does not receive acknowledgment from DHCP that the records had been received within 3 tries, the VITEK turns its interface off. When this occurs several things must be remembered:
 - a. The VITEK will not transmit data again until the operator turns the interface back on.
 - b. Once the interface has been turned back on the operator can retransmit records ONLY if the cards have NOT been removed from the VITEK. If the cards have been removed, the entire test must be rerun or the result must be entered manually into DHCP.
3. This system was written to support revision AI or later of the VITEK software. Sometime around Revision L, there was a change in the reporting of values out of the VITEK. Then with Revision W to Revision AI, values were periodically changed along with a change in NCCLS interpretations. Therefore, we will ONLY support Revision AI or later.
4. With the release of VITEK AMS software version DSAMS-R06.1, there was a change in the byte positions used for transmitting the drug code for each antimicrobial on both the Gram positive and Gram negative susceptibility cards. This change in the VITEK data stream required an accompanying change in the DHCP program. The program used for the encoded upload on a bidirectional interface is LAMIVTE6. The program used for a unidirectional interface is LAMIVT6

IV. VITEK File Setup

A. Unidirectional

The VITEK does not require any special file setup to run in the unidirectional mode. If you are going to run the VITEK unidirectional, proceed to section V.

B. Bidirectional

The VITEK requires several tables to be defined by the operator before the instrument can be run in the bidirectional mode. These tables use abbreviations that are normally limited to a maximum of 6 characters and must be set up to match the corresponding DHCP files to accommodate downloaded information.

You will need access to information in the following DHCP files:

- HOSPITAL LOCATION file (#44)
- TREATING SPECIALTY file (#45.7)
- COLLECTION SAMPLE file (#62)
- TOPOGRAPHY FIELD file (#61)
- LABORATORY TEST file (#60)

Updating the first four VITEK files are optional (HOSPITAL LOCATION, HOSPITAL SERVICE file, SPECIMEN SOURCE file, and BODY TYPE file). However, it is recommended for Full Download. For each of the files listed below, refer to the proper section of this manual for VITEK instructions to obtain the procedure for adding data.

1. HOSPITAL LOCATION file

NOTE: This is the VITEK file, **not** the DHCP HOSPITAL LOCATION file (#44).

A file printout of this file will look like the following:

```
hospital name
hospital address
hospital section
name of chief
(date printed) Hospital Location Page 1
```

```
-----
lockey   loctext
-----
```

```
lbw      1 BW
2BW      2 B
2BS      2 BS Psychiatry
```

- a. Lockey - must match the abbreviation field (#1) of the DHCP HOSPITAL LOCATION file (#44) with a maximum of six (6) characters.
- b. Loctext - matches the name field (#.01) of the DHCP HOSPITAL LOCATION file (#44).

2. HOSPITAL SERVICE file

A file printout of this file will look like the following:

```
hospital name
hospital address
hospital section
name of chief
```

```
(date printed) Hospital service Page 1
```

```
-----
serkey           sertext
-----
```

```
NONE
MEDICI           MEDIC
NEUROL           NEUROLOGY
```

- a. Serkey - matches the first six characters of the name field (#.01) of the TREATING SPECIALTY file (#45.7).
- b. Sertext - matches the full name of the name field (#.01) of the TREATING SPECIALTY file (#45.7).

3. SPECIMEN SOURCE file

A file printout of this file will look like the following:

```
hospital name
hospital address
hospital section
name of chief
```

```
(date printed) specimen source Page 1
```

```
-----
source          srcdes          source group      ser-urin
-----
BLOOD           BLOOD CULTURE     BLOOD             S
CSF CSF/CEREBROSPINAL FLUID
BRONCH          BRONCHIAL WASHING FLUID
URINE           URINE             URINE             U
```

- a. Source - six (6) character abbreviation from the Synonym field (#8) of the DHCP COLLECTION SAMPLE file (#62).
- b. Srcdes: Name field (#.01) from the DHCP COLLECTION SAMPLE file (#62).

4. BODY SITE file

A file printout of this file will look like the following:

```
hospital name
hospital address
hospital section
name of chief
```

```
date printed    body site    Page 1    siteid    sitetext
-----
Y4100          ABDOMEN
42500          ABDOMINAL AORTA
2Y414          BRONCHIAL WASHING
```

- a. Siteid - matches the SNOMED code field (#2) of the TOPOGRAPHY FIELD file (#61).
- b. Sitetext - matches the name field (#.01) of the TOPOGRAPHY FIELD file (#61).

Hints

- There are many different methods for obtaining the data needed to complete the VITEK BODY SITE file. Here are two possible ways: (1) Do a FileMan print of the name field (#.01) and SNOMED Code field (#2) from the DHCP TOPOGRAPHY FIELD file (#61).

NOTE: The TOPOGRAPHY FIELD file (#61) contains several thousand entries.

- Use this printout to select the desired sites and SNOMED codes for entry into the VITEK BODY SITE file.
- Use the DHCP Lab accession and test counts [LRUPAC] option to generate a list of previously used culture sites for a specified time frames (i.e., two years). Use this list as a worksheet to look up the SNOMED codes and then again as a worksheet for entry into the VITEK BODY SITE file.

5. EXAM TYPE file

A file printout of this file will look like the following:

hospital name
hospital address
hospital section
name of chief

(date printed)	exam type	Page 1	culcode	culname	alink	capunit
	BLOOD		BLOOD CULTURE			300.0
	CULTUR		CULTURE & SENSITIVITY			300.0
	FUNGAL		FUNGAL CULTURE			300.0
	GRAM S		GRAM STAIN			300.0

- a. Culcode - Matches the first six (6) characters for the test name from the name field (#.01) of the LABORATORY TEST file (#60).
- b. Culname - matches the name field (#.01) of the LABORATORY TEST file (#60).

- Print File #60, by selecting **only** the accession area Microbiology. This will eliminate CHEM and HEMO tests.

V. DHCP File Setup

A. General Information

There are a number of DHCP files which **must** be updated before you can run the instrument on-line. These files must be updated in the proper order for the system to work properly. Each of these will be discussed in the following sections in the order that they must be updated.

Because of the need for field sensitivity to system security, some of these files will require higher levels of FileMan access than most Lab personnel have. If, while editing these files, you do not see a field shown here, you will have to see your IRM service to have this data entered for you.

The VITEK will overlay DHCP data only if the organism name is an exact match.

Example: If GNR is entered as a preliminary result at the “Select ORGANISM:” prompt, the VITEK will not overlay the final ID of **E. Coli** instead **E. Coli** would be considered as a second isolate.

Each site will need to evaluate their workflow in relation to this occurrence. One possible solution is to use the Preliminary Bact Comment as a field for entry of 1+ GNR, etc. The execute code “Bacteriology” (File #62.07) may need to be edited to include this subfield (#1). (See Planning and Implementation Guide).

B. ETIOLOGY FIELD file (#61.2)

1. Obtain lists of all organisms which the VITEK will report. These are found in Tables 3.2, 3.5, 3.8, 3.9, 3.12, and 3.14 of the VITEK Computer Interface Specification. All organisms listed in the VITEK must have an entry in the ETIOLOGY FIELD file (#61.2). “Slash call” organisms should be entered.
2. Refer to your Microbiology implementation section in this manual for the procedure for adding these organisms.

C. LAB DATA file (#63)

1. Refer to the VITEK documentation (Tables 4.4 and 5.4) for a list of all drugs reported by the VITEK. All drug entries must be included in the LAB DATA file (#63).
2. Refer to the Microbiology implementation section in this manual for the procedure in adding these New Antibiotics to LAB DATA file (#63).

D. ANTIMICROBIAL SUSCEPTIBILITY file (#62.06).

1. All new drug entries entered above must be added to the ANTIMICROBIAL SUSCEPTIBILITY file (#62.06).
2. Entries in the ANTIMICROBIAL SUSCEPTIBILITY file (#62.06) should include entries in the fields:
 - 2 Susceptibility Results
 - .01Susceptibility Result(MIC Value)
 - 1 Default Interpretation
 - 3 Alternate Interpretation

Refer to VITEK documentation (Table 4.4 and 5.4) for MIC values and category interpretations for each antibiotic.

3. Refer to your Microbiology implementation section in this manual for the procedure to add new drugs to the system and add any drug not already in the file.

E. LABORATORY TEST file (#60)

1. A new field was defined in this file called Culture ID Prefix.
2. The VITEK will only accept unique accession numbers. Since a given accession containing more than one test is not considered unique by the VITEK, use of a prefix for all accessions resolves this problem.
3. Enter a number between zero (0) and nine (9) in this field to be used as a prefix to the accession number for this test. The user must enter this prefix along with the accession number directly on the VITEK card. Then when the download program is run, the prefix will be automatically added to the accession number to make it unique. The upload program will strip the prefix off so that it does not interfere with the verification process.

If this field is not filled in, the download program will not build a record for downloading which has this test on it.

When the VITEK cards are read to determine the accession number, a blank location is considered a zero (0). Assigning the most commonly downloaded test (C&S) a prefix of 0 in the LABORATORY TEST file (#60) will eliminate the need to enter a prefix on the VITEK card for any C&S.

F. LABORATORY SITE file (#69.9)

1. A new field has been added—DOWNLOAD FULL DATA—that must be filled in.
2. Answering this field with “YES” will cause the download program to download the maximum amount of demographic data it can to the VITEK.
3. An answer of “NO” will cause the program to download only those fields required by the VITEK to run the sample. These required fields are the Patient ID (SSN), the Specimen ID (accession number), the Culture ID (accession number plus prefix), and the Culture Type (test name from File #60).

G. LOAD/WORK LIST file (#68.2).

1. While the VITEK is not inherently a tray/cup type instrument, it is run this way by our system. A Load/worklist must be set up for the download routines to be able to build and send the DOWNLOAD file to the instrument.
2. The following is an example of a load/work list for the VITEK:

```
Select LOAD/WORK LIST NAME: VITEK
LOAD TRANSFORM: UNIVERSAL
TYPE: TRAY/CUP
CUPS PER TRAY: 30
FULL TRAY'S ONLY: NO
EXPAND PANELS ON PRINT:
INITIAL SETUP:
VERIFY BY: ACCESSION
PROFILE: MISC
ACCESSION AREA: MICROBIOLOGY
TEST: GC CULTURE
BUILD NAME ONLY: NO
TEST: C&S
BUILD NAME ONLY: NO
TEST: QUANTITATIVE CULTURE
BUILD NAME ONLY: NO
```

H. AUTO INSTRUMENT file (#62.4)

1. The AUTO INSTRUMENT file (#62.4) comes with an entry for the VITEK, which is used for both unidirectional and bidirectional operation.
2. Use the VA FileMan Transfer Entries option to copy this entry to the instrument number of the LSI where the VITEK will run.

CAUTION: Do not Delete the entry at the end when VA FileMan asks you.

3. Using the VA FileMan Enter/Edit option, fill in the beginning fields of the new entry you have just created as follows:

```
Select AUTO INSTRUMENT NAME: VITEK
NAME: VITEK//
ECHO DEVICE:
PROGRAM: LAMIVTK//
```

if running a version before VITEK 6.1 Revision AO

- a. unidirectional enter LAMIVTK
- b. bidirectional enter LAMIVTKU

if running VITEK R 6.1 Revision AO or later

- a. unidirectional enter LAMIVT6
- b. bidirectional enter LAMIVTE6

```
LOAD/WORK LIST: VITEK// <RET>
ENTRY for LAGEN ROUTINE: Accession cross-reference
CROSS LINKED BY: +ID// <RET>
ECHO ALL INPUT: NO// <RET>
METHOD: VITEK// <RET>
DEFAULT ACCESSION AREA: MICROBIOLOGY// <RET>
OVERLAY DATA: YES// <RET>
NEW DATA: D NEW^LASET// <RET>
RESTART: D RESTART^LASET// <RET>
HANDSHAKE RESPONSE: D^LAMIVTKC// <RET>
```

- a. unidirectional enter S OUT=\$C(6)
- b. bidirectional enter D ^LAMIVTKC

```
ACK TRIGGER VALUE: <RET>
ACK RESPONSE VALUE: <RET>
Select TEST: ^LOAD CHEM
LOAD CHEM TESTS: <RET>
Select ALARM TERMINAL: <RET>
AMIS SUFFIX CODE: <RET>
```

4. Now we will be working with several multiples fields starting with the Micro Card Type. There are many card types defined. Each of these will require updating.

The following discussion on card types will be more meaningful if you reference Appendix D of the VITEK Computer Interface Specification documentation for a numerical listing of all the valid cards for the VITEK.

NOTE: The Appendix D is part of your Vitek instrument documentation. We do not include a copy as it is continually updated by the manufacturer.

⚠️ **WARNING:** These predefined card types must NEVER be deleted as all flex cards will be referring to these cards for data conversion.

Card 0F is the main Gram Positive Identification (GPI) card and contains the gram positive organisms listed in table 3.8 of the VITEK manual.

Card 0FB is the secondary Gram Positive Identification card and holds table 3.9 of gram positive organisms. This card is a pseudo card and does not have a card call.

NOTE: The 0F and 0FB cards are used by the processing routines as required by the data being passed by the VITEK for lookup of any Gram positive organism.

Card 0E is the Gram Negative Identification card (GNI) and contains table 3.5 of gram negative organisms. This card is used for look up of organisms for all gram negative cards.

Card 0C is used for organism look up when doing Bacillus Identification (BACIL) and contains table 3.2 of Bacillus organisms.

Card 05 is used for organism look up when doing Yeast identification (YBC) and contains table 3.14 of Yeast organisms.

Card 0B is used for urine identification for the UID-1 card and contains table 3.12 list of organisms.

Card 12 is used for urine identification from the UID-3 card and contains table 3.12 list of organisms.

NOTE: The above examples are of the cards most likely to be used by a site.

```
Select MICRO CARD TYPE: 0F (HEX Code from VITEK APPENDIX D)
MICRO CARD TYPE: 0F// <RET>
CARD NAME: GPI// <RET>
PROCESS CARD CALL: D 511^LAMIV11// <RET>
```

Process card calls for the remaining card types are:

- a. For GPI card enter D 511^LAMIV11
- b. For GPI-2 card enter nothing.
- c. For GNI card enter D 512^LAMIV12
- d. For Bacillus card enter D 52^LAMIV10
- e. For Yeast card enter D 54^LAMIV11
- f. For UID-1 card enter D ^LAMIV10
- g. For UID-3 card enter D 510^LAMIV10
- h. For Gram Neg Flex cards enter D ^LAMIV12
- i. For Gram Pos Flex cards enter D ^LAMIV11

These card calls change the encoded VITEK data into an organism name, a drug name, a raw MIC value, and an interpretation, which will be displayed during verification.

5. Now within the MICRO Card Type field enter in the organisms **only** for those cards which are Identification type cards (i.e., Gram Negative Id, Gram Positive Id, Bacillus ID, etc.). If this is not an ID card but a Flex Susceptibility card leave this field blank and continue at Step #7 below.

For each organism enter the organism name as listed in the ETIOLOGY FIELD file (#61.20) and its card code from tables 3.2, 3.5, 3.8, 3.9, 3.12, or 3.14 in the VITEK Computer Interface Specification. Many organisms will have multiple entries. Use the conventional FileMan method of quotes around the name (organism) to enter an organism after the first entry has been made.

```
Select ORGANISM: STREPTOCOCCUS PYOGENES
ORGANISM: STREPTOCOCCUS PYOGENES// <RET>
CARD CODE FOR ORGANISM: 00// <RET> (HEX code from table 3.8)
Select ORGANISM: <RET>
```

6. Continue adding organisms for this card type until you have them all entered. When you have them entered for this card type use the ^ to leave this card type and return to the "MICRO CARD TYPE" prompt and continue to Step #7 below.

7. For card types which are Flex panel cards, it will be necessary to add drugs to the card type along with several other pieces of data. Each drug listed for a given card type must be entered in the file. Some antimicrobials will have multiple entries, each with a different card code.

The routine LAMIV00 contains all the strings of code for processing the card data into raw MIC values. A printout of all line tags with comments (Printout A) is at the end of this section. Also included are printouts of the X replacement values in PARAM1 for GNS and GPS cards (Printouts B and C), respectively.

These printouts along with your VITEK Computer Interface Specification documentation of drug tables 4.4 and 5.4 and the Section references 4.3 (GNS Flex panel card configuration) and 5.3 (GPS Flex panel card configuration) will be used for filling in the PARAM1 field.

The line references within this routine have documentation for which interpretation table and which drug codes are valid for that string.

```
Select MICRO CARD TYPE:13 (HEX CODE FROM VITEK APPENDIX D)
MICRO CARD TYPE: 13// <RET>
CARD NAME: GNS// <RET>
PROCESS CARD CALL: D ^LAMIV12// <RET> (See above)
Select ORGANISM: <RET>
Select DRUG: CHLORAM (See VITEK Section 4.3, GNS CARD
CONFIGURATION)
DRUG: CHLORAM// <RET>
DRUG NODE:2.0008// (No Editing)
PARAM1:S LARTN="x"_U_"LAMIV00" D @LARTN
```

- a. The string of code above is the same for all PARAM1 fields except for the character x.
- b. To determine the value for the character x refer to the card configuration reference in section 4.3 (GRAM NEGATIVE) or 5.3 (GRAM POSITIVE) of the VITEK Computer Interface Specification. In this example we are dealing with the GNS card which is the first card listed in section 4.3.
- c. Referring to VITEK Table 4.4, we see that the drug, Chloramphenicol, has several interpretations listed — one set of interpretations for a card code of 6 and another set of interpretations for a card code of d.
- d. The drug Chloramphenicol has two possible card codes to be entered. Let's focus on the second code d.

- e. Referencing Printout B (GNS CARD TYPES) of DHCP VITEK Interface Guide, look down the list of GNS drugs until you find Chloramphenicol with a CODE of "d". The x replacement value is "8".
- f. Enter the PARAM1 string as shown above and replace the x character with the code given for this card and drug code listed Printout B.
- g. Therefore the string of code for PARAM1 will be entered as:

S LARTN="8"_U_"LAMIV00" D @LARTN

If the drug has more than one code for the Flex card the drug must be added one time for each code that is used. As in this case, we would have to add Chloramphenicol a second time with a card code of "6" and the x PARAM1 field having a value of "7".

Card Code: d//

This is the drug code for this drug as listed in the VITEK computer interface specifications section 4.3 (GRAM NEGATIVE) or 5.3 (GRAM POSITIVE) card types.

There are some drugs with card codes of "@^?" which cannot be added through FileMan. When these codes are encountered, leave the card code field blank. After the card type is completed, we will run a routine which will add these codes.

Display Order: 7//

This field controls the order of display of the drugs during verification. In most cases, this would be the order in which the results are printed on the VITEK printer. If a given drug has multiple entries for this card type, each entry should have the **same** display order.

Section:
Bit Position:
Select Drug:

8. Continue adding drugs for this card type until you have them all entered. When you have completed entering drugs, enter “^” at the “Select Drug” prompt to take you back to the “MICRO CARD TYPE” prompt.

```

Select MICRO CARD TYPE: <RET>
INTERFACE NOTES:. . .
221>
EDIT Option: <RET>
DOWNLOAD ENTRY: <RET>
DOWNLOAD PROTOCOL ROUTINE: <RET>
FILE BUILD ENTRY: <RET>
FILE BUILD ROUTINE: LAMIVTKD// <RET>
SEND TRAY/CUP LOCATION: no// <RET>
QUEUE BUILD: no// <RET>
MICRO INTERPRETATION CHECK: F
METH NAME: <RET>
MEAN DATA VALUE 1: <RET>
MEAN DATA VALUE 2: <RET>

```

9. Once you have filled in the data for the MICRO card types and finished the rest of the auto instrument entry you may have to run a routine to add the additional drug codes listed in Step #7 above. If you do not need to add any codes, go to step #11.
10. Adding drug codes “@^?” is done by running the option Load VITEK special characters. This routine (LRMICRA) will prompt the auto instrument entry, the card type, and then step through the drug nodes displaying the entered code. You can enter the code or press return to accept the default. The routine will either continue, when the return is pressed, or enter the code into the file and build the “C” cross-reference entry for you.

⚠WARNING: If the AUTO INSTRUMENT file (#62.4) is ever reindexed you will have to run this option again to re-enter these codes, as they will be lost.

11. You have now completed the AUTO INSTRUMENT file (#62.4).

VI. Operational Procedures

- A. **Unidirectional:** The VITEK in unidirectional mode requires no special procedure. The cards are placed in the incubators after being inoculated and marked with the accession number. When the results are available they will be automatically uploaded to DHCP and processed.
- B. **Bidirectional:** The operation in bidirectional mode is somewhat different than the unidirectional mode since the demographics and tests will be downloaded to the instrument. Information (for building the download files) is collected from the Load/Work List.

The following is a typical procedure to utilize the bidirectional capabilities after the accessioning process is completed.

1. The accession number with prefix is placed on the VITEK card to be run.
2. The card is inoculated.
3. The card is placed in the incubator.
4. The tech then uses the option Add accession to micro worklist to add the accessions and build the appropriate list.
5. After all accession have been added, the tech uses the Download to Micro Auto Instrument option. This option builds the download files and downloads them into the VITEK.
6. When the download is completed, the VITEK will begin processing the cards.
7. When the results are complete on the VITEK, the card is read and the results are uploaded to DHCP and processed.
8. The tech then uses the Verify Micro Auto Instrument Data option to edit/verify the data.

Troubleshooting for VITEK

Problem: No organism for this accession

Possible Causes & Solutions:

1. Organism has two or more columns of susceptibility results for one VITEK card.

Solution: Organism must be given Key I.D. on VITEK and retransmitted to DHCP.

2. The probability is < 80%, therefore the LAMIV1* programs will screen out these isolates and will not be transfer them to ^LAH.

3. Isolate needs to be Key ID on the VITEK

4. Organism has not been entered in AUTO INSTRUMENT file (#62.4).

Solution: Enter organism in AUTO INSTRUMENT file (#62.4), subfield micro card type, subfield organism.

5. Organism code in AUTO INSTRUMENT file (#62.4) is incorrect.

Solution: Refer to VITEK interface specifications. Correct organism code in AUTO INSTRUMENT file (#62.4).

6. Each organism in the AUTO INSTRUMENT file (#62.4) must have a cross reference, ^LAB(62.4,X,7,Card,2, "C"

Solution: Delete organism entry, reenter it in the AUTO INSTRUMENT file (#62.4), and then re-transmit data.

7. Organism is not properly identified in the ETIOLOGY FIELD file (#61.2).

Solution: All organisms added to the AUTO INSTRUMENT file (#62.4) must be identified as Bacterium, Fungus, or Mycobacterium.

8. Result was not sent from the VITEK or interface program was not running.

Solution: Retransmit, using the CISEND menu, Check status of lab program. Remember that the data can only be re-transmitted if the cards are still in the VITEK incubator.

Problem: Only one isolate is displayed, and ALL the VITEK cards for that accession number are displayed for that organism (e.g., Kleb pneumo GNI, GNSF1, GNSF2 cards run, Enterococcus GPSTA card run, yet all cards are displayed for Kleb pneumo).

Possible Cause and Solution:

Each isolate run on the VITEK must be given a unique ID number. The last digit is processed as the isolate number for that accession.

Solution: Be sure each isolate is assigned a unique ID number. For example, 3000-0 (gram neg isolate #1), 3000-1(gram positive isolate #1), 3000-2 (gram positive isolate #2). If you do not use the zero to indicate the first isolate, then 3000-1 is isolate #1.

Problem: Susceptibility Interpretation is incorrect

Possible Solutions:

1. Edit the drug in the ANTIMICROBIAL SUSCEPTIBILITY file (#62.06). Many drugs such as Ticarcillin and Mezlocillin have different interpretations, depending on the type of organism identified. Use the Alternate Interpretation field to set up correct interpretation for the isolate. Use the most common result for the field susceptibility result, and then enter the "exceptions" using the Alternate Interpretation field.
2. Check Param1 value for that drug in the AUTO INSTRUMENT file (#62.4). The MIC value is set when Param1 is executed.

Problem: Unable to use E to edit a drug sent from the VITEK

Possible Solution:

1. Add the drug to the Edit Template defined in File #63. The edit templates are associated with each organism in the ETIOLOGY FIELD file (#61.2). The template drugs may be changed by editing the template in File (#63).

Problem: No data uploaded for an accession

Possible Solutions:

1. Use VITEK CISEND menu to send a test pattern to ^LA WATCH the data in the ^LA global to check and see if the data gets there. If the test pattern is not sent to ^LA, check the interface cable or the LSI. Verify that the interface is enabled on the VITEK.
2. Verify that the lab job and auto instrument routine are running.

Problem: No data for VITEK worklist

Possible Solution: Check Param 1 values in AUTO INSTRUMENT file (#62.4). Clerical errors in this field could cause the program to error out. For example, an incorrect line tag entry would cause a <liner> error. If the program does not process the data successfully, no data will be transferred to ^LAH.

Problem: Unable to edit comments which were sent from the VITEK

Possible Solution: Check the Edit code in File #60 and in the EXECUTE CODE file (#62.07). This code determines which fields are displayed to the user. Special messages which are uploaded from the VITEK to DHCP are stored as comments in File #60 (LAB DATA), Field #5 (Microbiology), Subfield #12 (organism), and Subfield #2 (Comment).

Printout A

1aMIV00;SLC/DLG/FHS/DAL - PROCESS VITEK V VALUE FROM FILE ;7/20/90 09:37
 ;;;5.14P2;LAB;;07/15/92 12:13

IN PARAM1 OF THE DRUG NODE OF THE MICRO CARD TYPE OF THE AUTO INSTRUMENT FILE
 YOU ENTER S RUN="x"_LARTN D @RUN WHERE x IS THE LINE TAG WHICH WILL DETERMINE
 THE MIC VALUE.

0;	POS CODE 7=?C
1;	POS CODE 0<>B
2;NEG CODE 1	
3;NEG CODE [POS CODE G
4;	POS CODE 34
5;NEG CODE 79	POS CODE 5
6;NEG CODE AD,	POS CODE 9 ab
7;NEG CODE 68,	POS CODE 8 QR
8;NEG CODE d	POS CODE 2@
9;	POS CODE :
A;NEG CODE \	POS CODE DI
B;NEG CODE 345,	POS CODE 1
C;NEG CODE 0,	
D;NEG CODE ;	
E;NEG CODE <	
F;NEG CODE Tjt	POS CODE H
G;NEG CODE NPR grs	POS CODE E NOS
H;NEG CODE HI	POS CODE M
I;NEG CODE C	
J;NEG CODE MWXY] yxz	POS CODE F
K;NEG CODE GV	
L;NEG CODE FJO_akl	
M;NEG CODE >?@	
N;NEG CODE :	
O;NEG CODE bc	
P;POS CODE ;A	
Q;NEG CODE SU	
R;NEG CODE Zfuy	POS CODE P
S;NEG CODE K^	
T;NEG CODE Qghmnop	
U;NEG CODE 2`	
V;NEG CODE i	POS CODE 6
W;NEG CODE L	
X;NEG CODE E	
Y;NEG CODE e	
Z;NEG CODE =	
A1;	POS CODE J
A2;	POS CODE K
A3;	POS CODE L
A4;NEG CODE B	
A6;NEG CODE w	POS CODE T

Printout B

NOTE: This printout is an example only. Due to the constant updating by MicroScan, you should consult the manufacturers literature for the most recent information.

GNS Card Types

DRUG CODE	DRUG NAME	'x' REPLACEMENT VALUE FOR PARAM1
O	AMIKACIN	C
;	AMIKACIN	D
X	AMOXICILLIN/CA	J
1	AMPICILLIN	2
<	AMPICILLIN	E
F	AZLOCILLIN	L
_	AZLOCILLIN	L
Y	AZTREONAM	J
2	CARBENICILLIN	U
=	CARBENICILLIN	Z
`	CARBENICILLIN	U
3	CEFAMANDOLE	B
>	CEFAMANDOLE	M
M	CEFAZOLIN	J
N	CEFONICID	G
G	CEFOPERAZONE	K
H	CEFOTAXIME	H
Z	CEFOTETAN	R
4	CEFOXITIN	B
?	CEFOXITIN	M
W	CEFTAZIDIME	J
O	CEFTIZOXIME	L
a	CEFTIZOXIME	L
V	CEFTRIAXONE	K
P	CEFUROXIME	G
q	CEFUROXIME	G
5	CEPHALOTHIN	B
@	CEPHALOTHIN	M
6	CHLORAMPHENICOL	7
d	CHLORAMPHENICOL	8
S	CINOXACIN	Q
f	CINOXACIN	R
[CIPROFLOXACIN	3
\	ENOXACIN	A
7	GENTAMICIN	5
A	GENTAMICIN	6
T	IMIPENEM	F

Instrumentation and Interfacing

Q	MEZLOCILLIN	T
g	MEZLOCILLIN	T
h	MEZLOCILLIN	T
I	MOXALACTAM	H
U	NALIDIXIC ACID	Q
R	NETILMICIN	G
B	NITROFURANTOIN	A4
e	NITROFURANTOIN	Y
i	NITROFURANTOIN	V
l	NORFLOXACIN	J
j	NORFLOXACIN	F
J	PIPERACILLIN	L
k	PIPERACILLIN	L
l	PIPERACILLIN	L
8	TETRACYCLINE	7
C	TETRACYCLINE	I
K	TICARCILLIN	S
L	TICARCILLIN	W
m	TICARCILLIN	T
n	TICARCILLIN	T
^	TICARCILLIN/CA	S
o	TICARCILLIN/CA	T
p	TICARCILLIN/CA	T
9	TOBRAMYCIN	5
D	TOBRAMYCIN	6
:	TRIMETH-SULFA	N
E	TRIMETH-SULFA	X
b	TRIMETH-SULFA	O
c	TRIMETH-SULFA	O
r	AMPICILLIN/SULBACTAM	G
w	OFLOXACIN	A6
s	CEFSULODIN	G
t	DOXYCLINE	F
u	FOSFOMYCIN	R
v	MINOCYCLINE	
x	CEFACLOR	J
y	CEFOTIAM	R
z	CEPHRADINE	J
10	NITROXOLIN	J

Printout C

NOTE: This printout is an example only. Due to the constant updating by MicroScan, you should consult the manufacturers literature for the most recent information.

GPS Card Types

DRUG CODE	DRUG NAME	'x' REPLACEMENT VALUE IN PARAM1
D	AMOXICILLIN/CA	A
O	AMPICILLIN	1
<	AMPICILLIN	1
>	AMPICILLIN	1
B	AMPICILLIN	1
E	AMPICILLIN/SULBACTAM	G
F	CEFAZOLIN	J
1	CEPHALOTHIN	B
2	CHLORAMPHENICOL	8
@	CHLORAMPHENICOL	8
G	CIPROFLOXACIN	3
3	CLINDAMYCIN	4
4	ERYTHROMYCIN	4
5	GENTAMICIN	5
K	GENTAMICIN	A2
6	NITROFURANTOIN	V
H	NORFLOXACIN	F
:	OXACILLIN	9
I	OXACILLIN	A
7	PENICILLIN G	O
=	PENICILLIN G	O
?	PENICILLIN G	O
C	PENICILLIN G	O
J	RIFAMPIN	A1
L	STREPTOMYCIN	A3
8	TETRACYCLINE	7
;	TRIMETH-SULFA	P
A	TRIMETH-SULFA	P
9	VANCOMYCIN	6
a	VANCOMYCIN	6
b	VANCOMYCIN	6
M	CEFOTAXIME	H
O	CEFUROXIME	G
P	FOSFOMYCIN	R
Q	FUSIDIC ACID	7
R	IMIPENEM	7
S	NETILMICIN	G
T	OFLOXACIN	A6

Printout D

NOTE: This printout is an example only. Due to the constant updating by MicroScan, you should consult the manufacturers literature for the most recent information.

Micro Card Type: 13

NUMBER: 7	NAME: VITEK BI-DIRECTIONAL
PROGRAM: LAMIVTE6	LOAD/WORK LIST: VITEK
ENTRY FOR LAGEN ROUTINE: Accession cross-reference	
CROSS LINKED BY: +ID	ECHO ALL INPUT: YES
METHOD: VITEK	DEFAULT ACCESSION AREA:
MICROBIOLOGY	
OVERLAY DATA: YES	HANDSHAKE RESPONSE: D ^LAMIVTKC
NEW DATA: D NEW^LASET	RESTART: D RESTART^LASET
MICRO CARD TYPE: 13	CARD NAME: GNS
ORGANISM: ESCHERICHIA COLI	CARD CODE FOR ORGANISM: 00
ORGANISM: PROTEUS MIRABILIS	CARD CODE FOR ORGANISM: 01
ORGANISM: PROTEUS SP	CARD CODE FOR ORGANISM: 02
ORGANISM: KLEBSIELLA SP	CARD CODE FOR ORGANISM: 03
ORGANISM: PSEUDOMONAS AERUGINOSA	CARD CODE FOR ORGANISM: 04
ORGANISM: PSEUDOMONAS SP	CARD CODE FOR ORGANISM: 05
ORGANISM: CITROBACTER SP	CARD CODE FOR ORGANISM: 06
ORGANISM: ENTEROBACTER SP	CARD CODE FOR ORGANISM: 07
ORGANISM: SERRATIA SP	CARD CODE FOR ORGANISM: 08
ORGANISM: PROVIDENCIA SP	CARD CODE FOR ORGANISM: 0A
ORGANISM: PSEUDOMONAS MALTOPHILIA	CARD CODE FOR ORGANISM: 0B
ORGANISM: ACINETOBACTER SP	CARD CODE FOR ORGANISM: 0C
NUMBER: 1	DRUG: AMIKACN
DRUG NODE: 2.0016	PARAM1: S LARTN="C"_U_"LAMIV00" D
@LARTN	
CARD CODE: 0	DISPLAY ORDER: 1
NUMBER: 2	DRUG: AMPICLN
DRUG NODE: 2.0012	PARAM1: S LARTN="2"_U_"LAMIV00" D
@LARTN	
CARD CODE: 1	DISPLAY ORDER: 2
NUMBER: 3	DRUG: CARBENICILLIN
DRUG NODE: 2.0013	PARAM1: S LARTN="U"_U_"LAMIV00" D
@LARTN	
CARD CODE: 2	DISPLAY ORDER: 3
NUMBER: 4	DRUG: CEFMAND
DRUG NODE: 2.0017	PARAM1: S LARTN="B"_U_"LAMIV00" D
@LARTN	
CARD CODE: 3	DISPLAY ORDER: 4

Instrumentation and Interfacing

NUMBER: 5 DRUG NODE: 2.0018 @LARTN CARD CODE: 4	DRUG: CEFOXITIN PARM1: S LARTN="B"_U_"LAMIV00" D DISPLAY ORDER: 5
NUMBER: 6 DRUG NODE: 2.0034 @LARTN CARD CODE: 5	DRUG: CEPHALOTHIN PARM1: S LARTN="B"_U_"LAMIV00" D DISPLAY ORDER: 6
NUMBER: 7 DRUG NODE: 2.0008 @LARTN CARD CODE: 6	DRUG: CHLORAM PARM1: S LARTN="7"_U_"LAMIV00" D DISPLAY ORDER: 7
NUMBER: 8 DRUG NODE: 2.0007 @LARTN CARD CODE: 7	DRUG: GENTMCN PARM1: S LARTN="5"_U_"LAMIV00" D DISPLAY ORDER: 8
NUMBER: 9 DRUG NODE: 2.0011 @LARTN CARD CODE: 8	DRUG: TETRCLN PARM1: S LARTN="7"_U_"LAMIV00" D DISPLAY ORDER: 9
NUMBER: 10 DRUGNODE: 2.0014 @LARTN CARD CODE: 9	DRUG: TOBRMCN PARM1: S LARTN="5"_U_"LAMIV00" D DISPLAY ORDER: 10
NUMBER: 11 DRUG NODE: 2.0015 @LARTN CARD CODE::	DRUG: TRMSULF PARM1: S LARTN="N"_U_"LAMIV00" D DISPLAY ORDER: 11
NUMBER: 14 DRUG NODE: 2.0013 @LARTN CARD CODE: `	DRUG: CARBENICILLIN PARM1: S LARTN="U"_U_"LAMIV00" D DISPLAY ORDER: 3
NUMBER: 22 DRUG NODE: 2.0015 @LARTN CARD CODE: b	DRUG: TRMSULF PARM1: S LARTN="O"_U_"LAMIV00" D DISPLAY ORDER: 11
NUMBER: 23 DRUG NODE: 2.0008 @LARTN CARD CODE: d	DRUG: CHLORAM PARM1: S LARTN="8"_U_"LAMIV00" D DISPLAY ORDER: 7
PROCESS CARD CALL: D ^LAMIV12	
NUMBER: 1 FLAG VALUE: 0	CODE: 46 MESSAGE: Oxidase negative
NUMBER: 2 FLAG VALUE: 1	CODE: 46 MESSAGE: Oxidase positive

Printout E

VITEK Printout Results

Accession # 3130

AMS ID 503130-0 (A1-5) DSAMS0-R6.4
Report date: Tue Jul 24 11:55:47 1992
Type: Gram Negative Identification Card
FINAL Elapsed time: 4 hours

DP3 -	OFG +	GC +	ACE -	ESC +	PLI +
URE +	CIT +	MAL +	TDA -	PXB -	LAC +
MLT +	MAN +	XYL +	RAF +	SOR +	SUC +
IND +	ADO +	COU -	H2S -	ONP +	RHA +
ARA +	GLU +	ARG -	LYS +	ORN -	OXI -

3371776364

99 % *Klebsiella pneumoniae* (indole -)/*oxytaca* (indole +)

1 % *Enterobacter aerogenes*

AMS ID 503130-0 (A1-6) DSAMS0-R6.4
Report date: Tue Jul 24 11:55:48 1992
Type: Gram Negative General Susceptibility - F1
FINAL Elapsed time: 5 hours

Cefazolin	<=8 S
Ceftazidime	<=8 S
Ceftriaxone	<=8 S
Gentamicin	>=16 R
Amikacin	<=2 S
Cefotetan	>=16 S
Cefoxitin	<=2 S
Cefuroxime-sodium	<=4 S
Cefuroxime-axetil	<=4 S
Cephalothin	>=32 R
Tobramycin	>=16 R

MIC values in mcg/ml (M2) Oxidase negative

GNI ID: *Klebsiella pneumoniae* (indole -)/*oxytaca* (indole +)
3371776364

AMS ID 503130-0 (A1-7) DSAMS0-R6.4
 Reportdate: TueJul 24 11:55:49 1992
 Type: Gram Negative General Susceptibility - F2
 FINAL Elapsed time: 5 hours
 Ampicillin >=32 R
 Ciprofloxacin <=0.5 S
 Piperacillin >=256 R
 Tetracycline >=16 R
 Trimeth-sulfa <=10 S
 Aztreonam <=8 S
 Carbenicillin >=512 R
 Imipenem <=4 S
 Mezlocillin >=256 R
 Ticarcillin >=256 R
 Ticarcillin/CA >=256 R
 MIC values in mcg/ml(M2) Oxidase negative
 GNI ID: Klebsiellapneumoniae (indole -)/oxytoca (indole +)
 3371776364

AMS ID 503130-0 (A1-6) DSAMS0-R4.01
 Report date: Tue Jul 24 11:55:48 1990
 Type: Gram Negative General Susceptibility - F1
 FINAL Elapsedtime: 5 hours

Albacillin/Sulbact >=32 R
 Cephalothin >=32 R
 Ciprofloxacin <=0.5 S
 Clindamycin >=8 R
 Erythromycin >=8 R
 Oxacillin >=8 R
 Penicillin >=16 R
 Tetracycline >=16 R
 Trimeth-sulfa <=10 S
 Vancomycin <=0.5 S
 Beta lactamase Positive

MIC values in mcg/ml (M2)Catalase positive
 Keyboard ID:Coag negative staph.
 Mate not resident
 CF, CA, AMOX/CA, AMP/SULB reported as "R" for oxacillin-resistant staph-NCCLS

INTERFACE GUIDE FOR OE/RR PACKAGE

Interface Guide for OE/RR Package

NOTE: Please refer to the OE/RR documentation for the most recent information.

1. Use this routine to load the lab protocols in the PROTOCOL file (#101). This should only be used the first time you install OE/RR.

D EN^LRX6

2. Use the OE/RR Interface Parameters options, on the Lab Liaison Menu to edit the parameters as indicated by the OE/RR documentation.

Comments:

1. Integration between the Laboratory package and OE/RR can be switched “ON” or “OFF” by editing a single field. To do so, edit the ON field in the Package Site Parameters multiple field of the ORDER PARAMETERS file (#100.99).
2. A cross reference exists in LABORATORY TEST file (#60), Field #200.01 to enhance the capability to check for duplicate orders.
3. Review the accuracy and applicability of the Laboratory administration schedules.

ROUTINE DESCRIPTIONS

Routine Descriptions

Routine Descriptions

The section of the Technical manual provide a list of Laboratory V. 5.2 software package routines and first line descriptions.

Conversion routines

LR52CNV;SLC/MRH/FHS - DRIVER FOR THE LAB DATA CONVERSION TO FILE 200
LR52CNV0;SLC/MRH/FHS - UTILITIES FOR 5.2 DATA CONVERSION
LR52CNV1;SLC/MRH/FHS ; Callable DATE-TIME functions
LR52CNV3;SLC/MRH/FHS - NEW PERSON CONVERSION FOR LAB ^LR(
LR52CNV4;SLC/MRH/FHS - continuation of LR52CNV3
LR52CNV5;SLC/MRH/FHS - NEW PERSON CONVERSION FOR LAB ^LRD(65 ; 1/23/91
LR52CNV7;SLC/MRH/DALISC/FHS - NEW PERSON CONVERSION FOR LAB ^LRO(67.9; 1/23/91
LR52CNV8;SLC/MRH/FHS - NEW PERSON CONVERSION FOR LAB ^LRO(68;1/23/91
LR52CNV9;SLC/MRH/FHS - NEW PERSON CONVERSION FOR LAB ^LRO(69...;
LR52CNVA;SLC/MRH/FHS - NEW PERSON CONVERSION FOR LAB ^LAR("Z" ; 1/23/91
LR52CNVP;DALISC/J0-REPRINT CONVERSION EXCEPTION REPORT ;01/08/93
LR52CNVU;DALISC/FHS - NEW PERSON CONVERSION FOR LAB ^LR(CONTINUED
LR52CNVX;SLC/AM/DALISC/FHS - WKLD (CAP) CODE LIST REPORT PRE INSTALL 5.2
;1/16/91 15:34 ;
LR52NTEG;ISC/XTSUMBLD KERNEL - Package checksum checker ;JAN 04, 1994@18:44:16
LR52TIM2;DALISC/J0-CONVERSION TIMES REPORT ;12/11/92
LR52TIME;DALISC/J0-CONVERSION TIMES REPORT ;12/11/92

Regular routines

LRABG ;SLC/RWF - PULMONARY LAB DATA DISPLAY ; 8/25/87 08:27 ;
LRABG1 ;SLC/RWF - PULMONARY LAB DATA DISPLAY ; 2/22/87 2:08 PM ;
LRAC ;SLC/DCM/MILW/JMC - CUMULATIVE REPORTS DRIVER ;2/20/91 08:33 ;
LRAC1 ;SLC/DCM/MILW/JMC - CUMULATIVE CONT. ;2/19/91 09:55 ;
LRAC2 ;SLC/DCM - CUMULATIVE CONT. ; 12/12/88 10:16 ;
LRAC2A ;SLC/DCM - CUMULATIVE CONT. ; 25 Oct 88 2:56 PM ;
LRAC3 ;SLC/DCM - PRINT CUMULATIVE REPORT ; 3/3/88 13:23 ;
LRAC4 ;SLC/DCM - PRINT CUMULATIVE REPORT ; 5/16/88 10:49 ;
LRAC5 ;SLC/DCM - PRINT CUMULATIVE REPORT ; 12/23/87 11:13 ;
LRAC6 ;SLC/DCM/MIWL/JMC - PRINT CUMULATIVE REPORT CONT. (MISC.); 1/31/89
15:02 ;
LRAC7 ;SLC/DCM - SET-UP FOR THE KILL ; 8/11/87 09:41 ;
LRAC8 ;SLC/DCM/MILW/JMC - REFORMAT ^LAC WHEN FILE 64.5 IS CHANGED; 10/2/87
11:30 ;
LRAC9 ;SLC/DCM - PRINT CUMULATIVE REPORT ; 3/3/88 13:25 ;
LRACC ;SLC/RWF - READ ACCESSION ; 7/10/87 17:38 ;
LRACDIAG ;SLC/DCM - DIAGNOSTIC REPORT FOR LAB REPORTS FILE (64.5);2/19/91 10:09;
LRACF ;SLC/RWA - FORCE PAGES TO FULL ;2/19/91 10:10
LRACFILE ;SLC/DCM - SORT FILE ROOM PATIENTS BY SSN ; 6/2/87 11:30 ;
LRACFIX ;SLC/DCM - REBUILD ^LRO(68,"AC") FROM A GIVEN DATE AFTER ALL LRAC X-
REF ARE REINITIALIZED. ; 5/30/86 2:47 PM ;
LRACFR ;MILW/JMC- Lab cumulative print filerom patients ;2/20/91 08:33 ;
LRACK ;SLC/DCM/MILW/JMC - CHECK CUMULATIVE DEVICE STATUS ; 9/30/87 15:11 ;
LRACKL ;SLC/DCM/MILW/JMC - CHUTES & LADDERS ; 2/16/88 16:15 ;
LRACKL1 ;DALISC/FHS/MIWL/JMC - CONTINUES CHUTES & LADDERS ; 03/24/92 18:40
LRACM ;SLC/DCM - MENU FOR CUMULATIVE REPORTS ;2/19/91 10:11 ;
LRACM1 ;SLC/DCM - MENU FOR CUMULATIVE REPORTS CONT. ;2/20/91 08:36 ;
LRACM2 ;SLC/DCM - MENU FOR CUMULATIVE REPORTS ;2/19/91 10:16 ;
LRACM2F ;MILW/JMC - LIST CUM PATIENT BY LOCATION

Routine Descriptions

LRACM3 ;SLC/DCM - REPRINT/INITIALIZE PATIENT CUM REPORT ;6/12/89 16:21 ;
LRACM4 ;SLC/DCM - INIT CUM REPORTS CONT. ; 9/10/87 09:55 ;
LRACP ;SLC/DCM - CUMULATIVE PURGE ;2/19/91 10:17 ;
LRACPG ;SLC/RWF - REMOVE LR(LRDFN,"PG") TO INITIALIZE PAT CUM;19 JUN 84
12:38PM ;
LRACS ;SLC/DCM - DAILY LAB SUMMARY REPORTS ;2/19/91 10:18 ;
LRACS1 ;SLC/DCM - DAILY LAB SUMMARY REPORTS ; 2/22/87 3:06 PM ;
LRACS2 ;SLC/DCM - LAB SUMMARY REPORT CONT. (MISC.) ; 2/22/87 3:08 PM ;
LRACS3 ;SLC/DCM - MISCELLANEOUS TESTS FOR SUPERVISORS SUMMARY;6/11/87 13:38 ;
LRACSUM ;SLC/DCM - INDIVIDUAL PATIENT SUMMARY. ;4/17/91 14:30 ;
LRACSUM1 ;SLC/DCM - INDIVIDUAL PATIENT SUMMARY CONT. ; 10/8/87 11:14 ;
LRACSUM3 ;SLC/DCM - PRINT INDIVIDUAL PATIENT SUMMARY ; 3/3/88 13:30 ;
LRACSUM4 ;SLC/DCM - PRINT INDIVIDUAL PATIENT SUMMARY ; 2/11/88 12:06 ;
LRACSUM5 ;SLC/DCM - PRINT INDIVIDUAL PATIENT SUMMARY ; 3/3/88 13:32 ;
LRACSUM6 ;SLC/DCM - PRINT INDIVIDUAL PATIENT SUMMARY (MISC.) ; 3/9/88 10:23 ;
LRAD2ORD ;SLC/CJS - ADD TESTS TO AN EXISTING ORDER ;2/5/91 11:31 ;
LRAFUNC ;SLC/MRH/FHS - FUNCTION CALLS A5AFUNC
LRAFUNC1 ;SLC/MRH/FHS - FUNCTION CALL DATE/TIME A5AFUNC1
LRAFUNC5 ;SLC/MRH/FHS - FUNCTION CALLS CONVERSION IN MEASUREMENTS A5AFUNC5
LRAFUNC6 ;SLC/MRH/FHS - FUNCTION CALLS CONVERSION IN MEASUREMENT A5AFUNC6
LRAFUNC7 ;SLC/MRH/FHS - FUNCTION CALL CONVERSION IN MEASUREMENT A5AFUNC7
LRAIPRIV ; DALISC/LD - DOD SITE'S PRIVACY ACT STATEMENT GEM/LL
LRAIRNUM ;DoD/GEM - DoD SPECIFIC ROUTINE FIND INPATIENT REGISTER NUMBER GEM/LL
; 12/9/86 2:24 PM ;
LRAP ;AVAMC/REG - ANATOMIC PATH UTILITY ;10/7/93 10:10 ;
LRAPA ;AVAMC/REG - ANAT PATH ACCESSIONS PER DAY ;2/18/93 10:25 ;
LRAPAP ;AVAMC/REG - ANATOMIC SORT BY PARENT FILE ; 10/25/88 20:15 ;
LRAPAU ;AVAMC/REG - AUTOPSY LIST ;2/18/93 10:26 ;
LRAPAU ;AVAMC/REG - PATHOLOGY LIST BY PATHOLOGIST/TECH ;3/4/94 09:26 ;
LRAPAU ;AVAMC/REG - ACCESSION COUNTS BY PATHOLOGIST ;2/18/93 10:27
LRAPAUPT ;AVAMC/REG - AUTOPSY PRINT ;5/9/91 18:17 ;
LRAPAU ;AVAMC/REG - AUTOPSY SUPPLEMENTARY REPORT ;3/11/94 08:41 ;
LRAPBK ;AVAMC/REG - AP LOG BOOK ;3/3/94 10:23 ;
LRAPBK1 ;AVAMC/REG - AP LOG BOOK ;1/12/94 12:55
LRAPBS ;AVAMC/REG - BLOCK/SLIDE DATA ENTRY ;3/7/92 10:14 ;
LRAPBS1 ;AVAMC/REG - BLOCK/SLIDE DATA ENTRY ;4/4/94 13:37 ;
LRAPBS2 ;AVAMC/REG - BLOCK/SLIDE DATA ENTRY ;2/6/92 19:19 ;
LRAPC ;AVAMC/REG - ANAT TOPOGRAPHY COUNTS ;2/18/93 10:30 ;
LRAPCUM ;AVAMC/REG - AP PATIENT CUM ;9/27/93 06:59 ;
LRAPCUM1 ;AVAMC/REG - AP PATIENT CUM ;7/15/93 10:36 ;
LRAPCWK ;AVAMC/REG - STUFF CYTOPATH WORKLOAD ;4/1/94 14:40
LRAPD ;AVAMC/REG - AP DATA ENTRY ;7/15/93 19:18
LRAPD1 ;AVAMC/REG - AP DATA ENTRY ;10/26/93 15:14
LRAPDA ;AVAMC/REG - ANATOMIC PATH DATA ENTRY ;3/7/94 07:51 ;
LRAPDAC ;AVAMC/REG - DELETE AP YEARLY ACCESSIONS ;5/9/91 18:12 ;
LRAPDEL ;AVAMC/REG - ANAT PATH DELETE DESCRIPTIONS ;9/30/93 07:01 ;
LRAPDPT ;AVAMC/REG - POW PTS ;3/18/94 08:58 ;
LRAPDS ;AVAMC/REG - AP REPORT DISPLAYS/PRINTS ;9/24/90 08:15 ;
LRAPED ;AVAMC/REG - ANATOMIC PATH EDIT LOG-IN ;8/20/93 14:28 ;
LRAPEDC ;AVAMC/REG - EDIT ANATOMIC PATH COMMENTS ;9/27/93 07:19 ;
LRAPF ;AVAMC/REG - CY/EM/SP RPT ;7/15/93 15:24 ;
LRAPFICH ;AVAMC/REG - MICROFICH PATH REPORTS ;2/18/93 10:31
LRAPFTS ;AVAMC/REG - AP FREE TEXT SEARCH ; 11/12/88 09:24 ;
LRAPH ;AVAMC/REG - HISTOLOGY RECORD ;2/18/93 10:33 ;
LRAPHDR ;AVAMC/REG - ANATOMIC PATH DEFAULTS ;7/16/93 06:25 ;
LRAPJNC ;AVAMC/REG - INCOMPLETE PATH RPTS ;2/18/93 10:34 ;
LRAPKOPT ;AVAMC/REG - DEL OBSOLETE OPTIONS/CREATE X-REF 62.5,5; 1/29/89 12:45 ;
LRAPL ;SLC/BA/AVAMC/REG - ANATOMIC PATH LABELS ;10/21/93 12:27 ;

Routine Descriptions

```

LRAPLG      ;AVAMC/REG - AP LOG-IN ;4/11/94  14:36 ;
LRAPLG1     ;AVAMC/REG - LOG-IN CONT. ;10/29/93  15:28 ;
LRAPLG2     ;AVAMC/REG - LOG-IN DATA FROM FILE #63 ;7/14/93  13:47 ;
LRAPM       ;AVAMC/REG - ANATOMIC PATH MODIFY MICRO/DX ;11/5/93  11:07 ;
LRAPMOD     ;AVAMC/REG - PRINT PATH MICRO MODIFICATIONS ;7/18/93  09:05 ;
LRAPMV      ;AVAMC/REG - MOVE AP ACCESSION ;9/11/92  14:27 ;
LRAPOLD     ;AVAMC/REG - ENTER OLD AP ACCESSIONS ;6/27/94  12:32 ;
LRAPONC     ;AVAMC/REG - FIND MALIGNANCIES FOR ONCOLOGY ;5/21/91  11:43
LRAPP       ;AVAMC/REG - AP PRINT ;11/22/92  11:03 ;
LRAPPA      ;AVAMC/REG - CY/EM/SP PATIENT RPT ;7/15/93  10:20 ;
LRAPPF      ;AVAMC/REG - ANATOMIC PATH FILE SORT ;2/18/93  10:35 ;
LRAPPF1     ;AVAMC/REG - ANAT PATH FILE PRINT BY PT ;2/21/91  12:47 ;
LRAPPF2     ;AVAMC/REG - ANAT PATH ACC# INDEX ;9/13/89  16:37 ;
LRAPPOW     ;AVAMC/REG - POW PATIENT LOOK-UP ;11/14/91  15:42 ;
LRAPPRE     ;AVAMC/REG - ANATOMIC PATH PRE-INIT ;10/6/90  12:29
LRAPQ       ;AVAMC/REG - ANAT PATH QUEUE LIST ;2/18/93  10:35 ;
LRAPQAC     ;AVAMC/REG - AP QA ;7/14/93  15:18 ;
LRAPQACD    ;AVAMC/REG - ENTER TC/QA CODES ;9/25/90  09:12
LRAPQACN    ;AVAMC/REG - CONSULTATION RPTS ;2/18/93  10:38
LRAPQAFS    ;AVAMC/REG - FROZEN SECTION/SURG PATH RPTS ;2/18/93  10:39
LRAPQAM     ;AVAMC/REG - PRINT PATH MICRO MODIFICATIONS ;2/18/93  10:39 ;
LRAPQAMR    ;AVAMC/REG - MALIGNANCY REVIEW ;7/14/93  14:59
LRAPQAR     ;AVAMC/REG - 10% SURG PATH REVIEW ;2/18/93  10:43
LRAPQAT     ;AVAMC/REG - TC CODE SEARCH ;2/18/93  10:44
LRAPQAT1    ;AVAMC/REG - QA CODE SEARCH ;4/17/91  14:31
LRAPQOR     ;AVAMC/REG - QA CODE REPORT ;2/18/93  10:45
LRAPQOR1    ;AVAMC/REG - QA CODE REPORT ;2/18/93  10:46
LRAPQOR2    ;AVAMC/REG - QA AUTOPSY DATA ;9/17/90  07:52
LRAPQOR3    ;AVAMC/REG - QA AUTOPSY DATA ;9/17/90  07:52
LRAPR       ;AVAMC/REG - ANAT RELEASE REPORTS ;5/9/94  14:37 ;
LRAPREF     ;AVAMC/REG - SNOMED REFERENCE OPTION SELECTOR ;3/9/94  13:20 ;
LRAPS       ;AVAMC/REG - AP PATIENT SCREEN DISPLAY ;3/11/94  14:06 ;
LRAPS1      ;AVAMC/REG - ANATOMIC PATH PRINT ;3/11/94  14:08 ;
LRAPS2      ;AVAMC/REG - AUTOPSY PRT ;1/28/93  13:02 ;
LRAPS3      ;SLC/DCM - AP PATIENT SCREEN DISPLAY FOR OE/RR ;12/10/90  12:21
LRAPSA      ;AVAMC/REG - TISSUE STAIN LIST ;2/18/93  10:46 ;
LRAPSE      ;AVAMC/REG - AP SEARCHES ; 7/29/88  17:53 ;
LRAPSEM     ;AVAMC/REG - MULTIAXIAL SNOMED SEARCH ;8/16/93  12:13 ;
LRAPSEM1    ;AVAMC/REG - SEARCH BY SNOMED CODE PRINT ;8/16/93  08:23 ;
LRAPSEM2    ;AVAMC/REG - SEARCH BY SNOMED CODE PRINT ;8/5/93  07:48 ;
LRAPSL      ;AVAMC/REG - ANATOMIC PATH SLIDE LABELS ;4/26/94  10:04 ;
LRAPSL1     ;AVAMC/REG - ANATOMIC PATH SLIDE LABELS ;5/9/91  12:08
LRAPSM      ;AVAMC/REG - SNOMED SEARCH ;2/18/93  10:52 ;
LRAPSM1     ;AVAMC/REG - SEARCH BY SNOMED CODE PRINT ;2/7/90  12:41 ;
LRAPST      ;AVAMC/REG - TISSUE STAIN LOOK-UP ;8/4/91  12:40 ;
LRAPST1     ;AVAMC/REG - AUTOPSY TISSUE STAIN LOOK-UP ;8/4/91  12:40 ;
LRAPSWK     ;AVAMC/REG - STUFF AP WORKLOAD ;9/3/93  08:35
LRAPT       ;AVAMC/REG - AP PATIENT RPT ;3/8/94  09:36 ;
LRAPT1      ;AVAMC/REG - ANATOMIC PATH PRINT ;9/13/89  16:19 ;
LRAPT2      ;AVAMC/REG - AUTOPSY PRT ;4/5/94  12:38 ;
LRAPT3      ;AVAMC/REG - AUTOPSY RPT PRINT COND(1)'T ;9/13/89  13:46 ;
LRAPTT      ;AVAMC/REG - TURNAROUND TIME PATH ;5/4/94  12:41 ;
LRAPTT1     ;AVAMC/REG - TURNAROUND TIME PATH ;1/4/93  10:56 ;
LRAPV       ;AVAMC/REG - ANAT PATH REPORTS NOT VERIFIED ;10/14/93  08:18 ;
LRAPWA      ;AVAMC/REG - GETP AP ACCESSION FOR WORKLOAD ;8/3/91  13:01
LRAPWE      ;AVAMC/REG - DATE/TIME GRIDS SCANNED/PRINTS MADE ;1/10/92  19:02
LRAPWE1     ;AVAMC/REG - STUFF EM SCANNED GRIDS ;4/22/93  10:03
LRAPWEA     ;AVAMC/REG - EM GRIDS SCANNED/PRINTS MADE ;1/12/92  18:04

```

Routine Descriptions

LRAPWKA ;AVAMC/REG - STUFF AP WORKLOAD ;4/23/93 07:25
LRAPWKA1 ;AVAMC/REG - STUFF SLIDE LABELS ;3/8/92 10:18
LRAPWR ;AVAMC/REG - DATE/TIME SLIDES READ ;1/10/92 07:12
LRAPWR1 ;AVAMC/REG - STUFF CYTOPATH SCREENED SLIDES ;5/5/93 10:39
LRAPWSPG ;AVAMC/REG - GROSS DESCRIPTION WORKLOAD ;8/4/91 09:25 ;
LRAPWU ;AVAMC/REG - AP WORKLOAD UTILITY ;4/1/94 14:33
LRAPX ;AVAMC/REG - AP CODING ;12/20/89 16:39 ;
LRAUAW ;AVAMC/REG - AUTOPSY DATA ENTRY ;11/25/92 09:00 ;
LRAUDA ;AVAMC/REG - AUTOPSY PATH DATA ENTRY ;6/10/94 14:20 ;
LRAUFIX ;AVAMC/REG - RELEASE AUTOPSY REPORTS ;2/18/93 13:47 ;
LRAUL ;AVAMC/REG - PATHOLOGY LIST BY PATHOLOGIST/TECH ;2/18/93 10:54 ;
LRAUMLK ;VAMC 695/MLK - AUTOPSY SLIDE LABELS;1/21/91 ;3/9/94 13:22
LRAURPT ;AVAMC/REG - AUTOPSY RPT ;4/5/94 12:44 ;
LRAURV ;AVAMC/REG - AUTOPSY DATA REVIEW ;2/18/93 12:24 ;
LRAUS ;AVAMC/REG - PRINT ICD SEARCH ;9/13/89 18:55 ;
LRAUSICD ;AVAMC/REG - AUTOPSY ICD9CM SEARCH ;3/9/94 13:24 ;
LRAUSM ;AVAMC/REG - AUTOPSY SNOMED SEARCH ;9/16/93 08:22 ;
LRAUSTA ;AVAMC/REG - AUTOPSY STATUS LIST ;2/19/93 10:27 ;
LRBARA ;SLC/RAF ;INTERMEC 4100 2 LABEL FORMAT 8/29/94 12:36
LRBARB ;SLC/JL/RAF ; INTERMEC 4100 10 PART LABEL FORMAT 8/29/94 12:36
LRBLA ;AVAMC/REG - BB ADM DATA ;4/16/93 10:20
LRBLA1 ;AVAMC/REG - BB ADM DATA ;2/18/93 08:20
LRBLA2 ;AVAMC/REG - BB ADM DATA ;2/26/92 09:20
LRBLAA ;AVAMC/REG - XM:TX BY TREATING SPECIALTY REPORT ;2/23/93 14:00 ;
LRBLAA1 ;AVAMC/REG - XM:TX BY TREATING SPECIALTY REPORT ;4/12/92 08:41 ;
LRBLAB ;AVAMC/REG - BB ADM DATA ;4/18/93 07:45
LRBLAGG ;AVAMC/REG - BLOOD BANK AGGLUTINATION STRENGTH ;3/9/94 10:29 ;
LRBLB ;AVAMC/REG - BLOOD BANK BAR CODE READER ; 11/12/88 15:15 ;
LRBLBU ;AVAMC/REG - BB UNIT BAR CODE ;1/15/90 14:17 ;
LRBLC ;AVAMC/REG - ABO/RH COUNT ;2/18/93 08:37 ;
LRBLCAP ;AVAMC/REG - BB CAP WORKLOAD ;3/3/93 14:31
LRBLCMV ;AVAMC/REG - UNIT PHENOTYPE BY ABO/RH ;9/13/89 19:30 ;
LRBLCON ;AVAMC/REG - LAB CONSULTS ;02/12/89 11:15 ;
LRBLD ;AVAMC/REG - CK BLOOD DONOR ENTRY ; 10/19/88 18:28 ;
LRBLDA ;AVAMC/REG - BLOOD DONOR LIST ;2/18/93 08:43 ;
LRBLDA1 ;AVAMC/REG - BLOOD DONOR LABELS ; 10/23/88 15:45 ;
LRBLDAA ;AVAMC/REG - DONOR/DEFERRAL LETTERS ;3/1/89 19:11 ;
LRBLDAL ;AVAMC/REG - BLOOD DONOR LETTERS ;7/18/91 08:52 ;
LRBLDC ;AVAMC/REG - DONOR COMPONENT PREP ;4/19/94 11:58 ;
LRBLDC1 ;AVAMC/REG - COMPONENT PREP WORKLOAD ;4/20/93 11:49
LRBLDCR ;AVAMC/REG - COMPONENT PREPARATION REPORT ;2/18/93 08:44 ;
LRBLDCU ;AVAMC/REG - CUMULATIVE DONATION CALCULATIONS ;2/18/93 08:47 ;
LRBLDED ;AVAMC/REG - BLOOD DONOR EDIT ;4/19/94 12:10 ;
LRBLDEL ;AVAMC/REG - DELETE FILE 65 ENTRIES ;8/14/90 14:36 ;
LRBLDELT ;AVAMC/REG - DELETE FILE 65 ENTRIES ;8/18/89 10:55 ;
LRBLDEX ;AVAMC/REG - EX-BLOOD DONORS ;2/18/93 08:54 ;
LRBLDEX1 ;AVAMC/REG - EX-BLOOD DONORS ;9/13/89 20:44 ;
LRBLDEX2 ;AVAMC/REG - EX-BLOOD DONORS ;12/13/89 11:30 ;
LRBLDK ;AVAMC/REG - DELETE EX-DONORS (65.5 ENTRIES) ; 11/12/88 13:19 ;
LRBLDL ;AVAMC/REG - BLOOD DONOR LIST ;2/18/93 08:55 ;
LRBLDL1 ;AVAMC/REG - BLOOD DONOR LABELS ; 10/23/88 15:45 ;
LRBLDLG ;AVAMC/REG - BB DONOR LOG-IN ;3/9/94 12:48 ;
LRBLDP ;AVAMC/REG - BLOOD DONOR PRINT OPTS ;6/23/92 09:23 ;
LRBLDPA ;AVAMC/REG - BLOOD DONOR PRINT ;2/18/93 08:57 ;
LRBLDPA1 ;AVAMC/REG - BLOOD DONOR PRINT ;6/24/90 20:57 ;
LRBLDPA2 ;AVAMC/REG - BLOOD DONOR PRINT ;6/24/90 20:57 ;
LRBLDPAW ;AVAMC/REG - BLOOD DONOR PRINT ;6/24/90 20:57 ;
LRBLDPH ;AVAMC/REG - DONOR PHENOTYPING ;3/9/94 12:51

Routine Descriptions

```

LRBLDPK   ; GENERATED FROM 'LRBL DONOR TESTING SUPPLEMENT' PRINT TEMPLATE
           (#1479) ; 07/27/94 ; (FILE 65.5, MARGIN=132)
LRBLDPL   ; AVAMC/REG - BLOOD DONOR LIST BY DATE ;2/18/93 09:00 ;
LRBLDPT   ; GENERATED FROM 'LRBL DONOR TESTING REPORT' PRINT TEMPLATE (#1475) ;
           07/27/94 ; (FILE 65.5, MARGIN=132)
LRBLDPT1  ; GENERATED FROM 'LRBL DONOR TESTING REPORT' PRINT TEMPLATE (#2590) ;
           01/20/93 ; (continued)
LRBLDR    ; AVAMC/REG - DONOR REGISTRATION FORM ;3/9/94 12:53 ;
LRBLDR1   ; AVAMC/REG - DONOR EXAM, COLLECTION ;2/11/94 07:50 ;
LRBLDRR   ; AVAMC/REG - REVIEW/RELEASE COMPONENTS ;3/25/92 22:12 ;
LRBLDRR1  ; AVAMC/REG - LABEL-RELEASE COMPONENTS COND'T ;10/27/92 09:49 ;
LRBLDRR2  ; AVAMC/REG - DO NOT RELEASE BLOOD COMPONENT ;2/4/93 12:06 ;
LRBLDSC   ; AVAMC/REG - DONOR SCHEDULING REPORT ;2/18/93 09:01
LRBLDT    ; AVAMC/REG - DONOR UNIT TESTING ;4/6/93 10:48 ;
LRBLDTA   ; AVAMC/REG - ABNORMAL DONOR TESTS ;2/18/93 09:04 ;
LRBLDUC   ; AVAMC/REG - DONOR ABO/RH RECHECK ;3/25/92 22:39 ;
LRBLDW    ; AVAMC/REG - BLOOD DONOR WORKLIST ;2/18/93 09:06 ;
LRBLDX    ; AVAMC/REG - DONOR ABO/RH TESTING ;3/25/92 22:42 ;
LRBLFIX   ; AVAMC/REG - FIX DISPOSITION X-REF ;8/14/92 12:54
LRBLJ     ; AVAMC/REG - BLOOD BANK INVENTORY OPTS ; 5/30/86 3:40 PM ;
LRBLJA    ; AVAMC/REG - BB INVENTORY DATA ENTRY ;7/16/93 15:02 ;
LRBLJA1   ; AVAMC/REG - BB INVENTORY WORKLOAD ;11/5/93 07:35
LRBLJB    ; AVAMC/REG - AUTOLOGOUS UNIT DISPOSITION LIST ;2/18/93 09:08
LRBLJC    ; AVAMC/REG - COMPONENT DISPOSITION LIST ;2/18/93 09:10
LRBLJCK   ; AVAMC/REG - INVENTORY ABO/RH CK ;11/5/93 10:31 ;
LRBLJD    ; AVAMC/REG - BB UNIT DISPOSITION ;6/10/94 10:20 ;
LRBLJD1   ; AVAMC/REG - POOL COMPONENTS ;6/10/94 11:27 ;
LRBLJDA   ; AVAMC/REG - BB UNIT DISP NEW UNIT ;6/10/94 10:22 ;
LRBLJDM   ; AVAMC/REG - MULTIPLE COMP PREP, INVENTORY ;2/11/93 14:56 ;
LRBLJDP   ; AVAMC/REG - PRINT UNIT DISPOSITION ;2/18/93 09:11 ;
LRBLJED   ; AVAMC/REG - BB INVENTORY EDIT ;6/27/94 14:34 ;
LRBLJI    ; AVAMC/REG - CHECK FILE ENTRIES ;2/18/93 09:14 ;
LRBLJL    ; AVAMC/REG - UNIT RELOCATION ;11/5/93 10:37 ;
LRBLJL1   ; AVAMC/REG - UNIT RELOCATION ;3/12/93 15:28 ;
LRBLJLA   ; AVAMC/REG - CROSSMATCH LABELS ;6/21/93 09:26 ;
LRBLJLG   ; AVAMC/REG - BB INVENTORY LOG-IN ;11/4/93 12:20 ;
LRBLJLG1  ; AVAMC/REG - REVIEW UNIT LOG-IN ;6/27/94 14:31 ;
LRBLJM    ; AVAMC/REG - EDIT POOLED UNIT ;3/9/94 13:01 ;
LRBLJM1   ; AVAMC/REG - EDIT POOLED UNIT ;7/12/92 22:09 ;
LRBLJP    ; AVAMC/REG - BB INVENTORY PRINT OPTS ;3/9/94 13:03 ;
LRBLJPA   ; AVAMC/REG - BB INVENTORY FINAL DISPOSITION ;2/18/93 09:22 ;
LRBLJPA1  ; AVAMC/REG - UNIT FINAL DISPOSITION ;12/28/92 09:24 ;
LRBLJPA2  ; AVAMC/REG - UNIT FINAL DISPOSITION ;9/14/89 07:13 ;
LRBLJPH   ; AVAMC/REG - UNIT PHENOTYPE BY ABO/RH ;2/18/93 09:26 ;
LRBLJPP   ; AVAMC/REG - PLATLET TX ;2/18/93 09:28 ;
LRBLJPP1  ; AVAMC/REG - PT ADM,RX SPECIALTY,ICD9CM CODES ;4/17/91 14:31 ;
LRBLJR    ; AVAMC/REG - RELEASE FROM XMATCH ;3/15/92 12:11 ;
LRBLJRB   ; AVAMC/REG - UNIT ISSUE BOOK ;2/18/93 09:30 ;
LRBLJSH   ; AVAMC/REG - BB INVENTORY SHIPMENTS ;2/18/93 09:31 ;
LRBLJT    ; AVAMC/REG - BB ITEMIZED TRANSACTIONS ;2/18/93 09:32 ;
LRBLJTS   ; AVAMC/REG - TRANSFUSION STATISTICS ;4/12/93 15:19 ;
LRBLJTS1  ; AVAMC/REG - TRANSFUSION STATS ;3/3/93 22:49 ;
LRBLJTS2  ; AVAMC/REG - TRANSFUSION STATISTICS ;9/14/89 08:54 ;
LRBLJU    ; AVAMC/REG - FIND UNITS NO DISPOSITION ;2/18/93 09:33 ;
LRBLJU1   ; AVAMC/REG - FIND UNITS NO DISPOSITION ;5/3/91 05:48 ;
LRBLJUT   ; AVAMC/REG - BB INVENTORY FINAL DISPOSITION ;3/9/94 14:02 ;
LRBLJW    ; AVAMC/REG - INVENTORY ABO/RH WORKSHEET ;7/28/93 07:29 ;
LRBLJX    ; AVAMC/REG - UNITS ON XMATCH ;2/18/93 09:36 ;

```

Routine Descriptions

LRBLP ;AVAMC/REG - BLOOD BANK PATIENT OPTS ;4/11/94 07:55 ;
 LRBLPA ;AVAMC/REG - GET PATIENT INSTR./TESTS ; 8/30/88 19:58 ;
 LRBLPAB ;AVAMC/REG - ANTIBODIES IDENTIFIED ;2/18/93 09:37 ;
 LRBLPB ;AVAMC/REG - PATIENT ANTIBODIES ;2/18/93 09:40 ;
 LRBLPBR ;AVAMC/REG - BB TESTS REPORT ;3/28/94 11:59 ;
 LRBLPBR1 ;AVAMC/REG - BB TESTS REPORT ;3/28/94 12:02 ;
 LRBLPC ;AVAMC/REG - TRANSFUSIONS/HEM RESULTS ;2/18/93 09:42 ;
 LRBLPC1 ;AVAMC/REG - PT ADM,RX SPECIALTY,ICD9CM CODES ;11/18/91 20:36 ;
 LRBLPCS ;AVAMC/REG - COMPONENT SELECTION FOR PATIENTS ;3/1/91 12:51 ;
 LRBLPCS1 ;AVAMC/REG - COMPONENT SELECTION CK PT SPEC ;10/26/90 12:0 ;
 LRBLPCSS ;AVAMC/REG - PRE-OP COMPONENT SELECTION ;7/23/93 15:36 ;
 LRBLPD ;AVAMC/REG - BB PT INFO ;2/18/93 09:42 ;
 LRBLPD1 ;SLC/DCM - BB PT INFO for OE/RR pt lists ;12/10/90 12:21
 LRBLPE ;AVAMC/REG - BB DATA ENTRY BY ACC # ;12/14/92 22:22 ;
 LRBLPE1 ;AVAMC/REG - PATIENT DRUG LIST ;2/6/91 09:54
 LRBLPED ;AVAMC/REG - PEDIATRIC UNIT PREPARATION ;3/15/92 11:33 ;
 LRBLPED1 ;AVAMC/REG - PEDIATRIC UNIT PREPARATION ;2/6/91 09:18 ;
 LRBLPED2 ;AVAMC/REG - PROCESS PEDIATRIC UNIT ;2/4/93 12:07 ;
 LRBLPEW ;AVAMC/REG - BB WORKLOAD ;3/9/94 13:09
 LRBLPH ;AVAMC/REG - PATIENT DRUG LIST ;2/18/93 09:44
 LRBLPIT ;AVAMC/REG - PROLONGED TRANSFUSION TIMES ;2/18/93 09:45 ;
 LRBLPP ;AVAMC/REG - BB PATIENT PRINT OPTS ; 7/18/88 07:0 ;
 LRBLPQA ;AVAMC/REG - TRANSFUSION REQUEST DATA ;2/18/93 09:45 ;
 LRBLPR ;AVAMC/REG - BLOOD BANK PT RECORD ;2/18/93 09:46 ;
 LRBLPR1 ;AVAMC/REG - BLOOD BANK PT RECORD-COND'T ;12/28/92 10:30 ;
 LRBLPRA ;AVAMC/REG - BB PT RECORD ;2/18/93 09:46 ;
 LRBLPT ;AVAMC/REG - TRANSFUSION RESULTS ;4/13/94 12:58 ;
 LRBLPT1 ;AVAMC/REG - TRANSFUSION RESULTS (COND'T) ;12/11/92 07:38 ;
 LRBLPTR ;AVAMC/REG - TRANSFUSION DATA REPORT ;2/18/93 09:47 ;
 LRBLPTR1 ;AVAMC/REG - TRANSFUSIONS/HEM RESULTS ;3/5/91 09:20 ;
 LRBLPUS ;AVAMC/REG - PATIENT UNIT SELECTION ;10/6/92 15:19 ;
 LRBLPUS1 ;AVAMC/REG - PATIENT UNIT SELECTION ;10/28/90 10:21 ;
 LRBLPUS2 ;AVAMC/REG - PATIENT UNIT SELECTION ;2/1/94 09:51 ;
 LRBLPX ;AVAMC/REG - XMATCH RESULTS ;12/13/93 08:55 ;
 LRBLPX1 ;AVAMC/REG - XMATCH RESULTS (COND'T) ;9/8/92 20:30 ;
 LRBLQPR ;AVAMC/REG - PRINT UNITS/COMPONENTS ;2/18/93 09:48 ;
 LRBLQST ;AVAMC/REG - SINGLE UNIT STATUS ; 2/14/89 17:04 ;
 LRBLRCT ;AVAMC/REG - CROSSMATCH:TRANSFUSION REPORT ;2/18/93 09:50 ;
 LRBLS ;AVAMC/REG - BLOOD BANK SUPERVISOR OPTS ;3/9/94 09:42 ;
 LRBLSET ;AVAMC/REG - SET DD(65.091,.03 ;7/23/92 12:39
 LRBLSSN ;DALISC/FHS/DVR/AVAMC/REG - SSN SYNTAX CHECKER/EDIT; 11/12/88 15:30 ;
 LRBLST ;AVAMC/REG - BB SUPERVISOR ;9/18/89 10:08 ;
 LRBLSTR ;AVAMC/REG - BB SUPERVISOR ;2/18/93 09:51 ;
 LRBLSUM ;AVAMC/REG - BLOOD BANK SUMMARY ;3/28/94 12:10 ;
 LRBLTA ;AVAMC/REG - TRANSFUSION REACTION COUNTS ;7/2/93 07:05 ;
 LRBLTA1 ;AVAMC/REG - TRANSFUSION REACTION COUNTS ;10/7/90 10:54 ;
 LRBLTX ;AVAMC/REG - TESTS FOR TX RELATED DISORDERS ; 2/17/88 20:59 ;
 LRBLTXA ;AVAMC/REG - TRANSFUSION FOLLOW-UP ;2/18/93 09:55 ;
 LRBLU ;AVAMC/REG - BB UTIL ;6/27/94 14:29 ;
 LRBLUL ;AVAMC/REG - BB UTIL ;4/13/93 07:17 ;
 LRBLVAL ;AVAMC/REG - OPTION VALIDATOR ;3/9/94 13:18
 LRBLW ;AVAMC/REG - STUFF WORKLOAD IN 65 ;11/5/93 10:38
 LRBLWD ;AVAMC/REG - STUFF WORKLOAD IN 65.5 ;2/7/91 18:45
 LRBLWDS ;AVAMC/REG - STUFF WORKLOAD IN 65.5 ;3/3/93 14:37
 LRBLXREF ;AVAMC/REG - SET BLOOD INVENTORY XREF ; 9/17/88 17:32 ;
 LRBLY ;AVAMC/REG - STUFF DATA IN LAB LETTERS ;2/20/89 16:15 ;
 LRCAP64 ;DALISC/FHS - PURGE 64.1 FILE LMIP PHASE 6
 LRCAP67 ;DALISC/FHS - PURGE 67.9 FILE LMIP PHASE 5

Routine Descriptions

LRCAPA12 ;SLC/RJS/FHS - LAB WORKLOAD DIVISION REPORT;8/23/91 1039;
 LRCAPACC ;SLC/RJS/FHS - LAB WORKLOAD DIVISION REPORT BY CAP CODE;8/23/91 1039;
 LRCAPAM0 ;SLC/FHS - INTRO FOR MOVE WKLD DATA FROM 64.1 TO 67.9;10/14/91 08:15
 LRCAPAM1 ;SLC/FHS - MOVE WKLD DATA FROM 64.1 TO 67.9;10/14/91 08:15
 LRCAPAM2 ;DALISC/FHS/JBM - PHASE 2 OF LMIP DATA COLLECTION 67.9 TO ^LAH(
 LRCAPAM3 ;SLC/FHS - LAB PHASE 3 LMIP DATA COLLECTION PRINT REPORT;8/23/91 1039;
 LRCAPAM4 ;SLC/RS/DALISC/FHS - LMIP PHASE 4 BUILD MAILMAN MESSAGES FOR LAB LMIP
 WORKLOAD TRANS ;8/23/91 1039;
 LRCAPAM5 ;DALISC/FHS - RCS 14-4 REPORT PART 1
 LRCAPAM6 ;DALISC/FHS - RCS 14-4 REPORT PART 2
 LRCAPAM7 ;DALISC/J0 - RCS 14-4 REPORT, LMIP PAGE COUNTERS ;5/10/93
 LRCAPAM8 ;DALISC/J0 - RCS 14-4 REPORT LMIP PAGE PRINT ;5/10/93
 LRCAPAM9 ;DALISC/FHS - RCS 14-4 REPORT LMIP SUPPLEMENT PAGE PRINT ;5/10/93
 LRCAPAMP ;DALISC/FHS - PURGE AND RE RUN LMIP PHASE 1
 LRCAPAUD ;SLC/FHS - DISPLAY WORKLOAD FOR ACCESSION ;2/13/91 11:05
 LRCAPBB ;SLC/AM/DALISC/FHS - STORE WORKLOAD FROM 65,65.5 INTO ^LRO(64.1
 ;4/17/91
 LRCAPD ;SLC/AM/DALISC/FHS/J0 - WORKLOAD CODE LIST REPORT;1/16/91 15:34 ;
 LRCAPDL ;DALISC/FHS - FORMATE DATA FROM 64.03 FOR DOWN LOAD TO SPREAD SHEET
 LRCAPF ;DALISC/FHS - STUFF WKLD CODE INTO FILE 60 61.2 62.07 ETC
 LRCAPMA ;SLC/AM/DALISC/FHS/J0 - WKLD REPORT BY MAJOR SECTION; 2/6/91@16:04
 LRCAPMA1 ;SLC/AM/DALISC/FHS/J0 - WKLD REPORT BY MAJ SCTN; 2/6/91
 LRCAPMA2 ;SLC/AM/DALISC/FHS/J0 - WKLD REPORT BY MAJOR SECTION; 2/6/91
 LRCAPMA3 ;SLC/AM/DALISC/FHS/J0 - WKLD REPORT BY MAJOR SECTION; 2/6/91
 LRCAPML ;SLC/AM/DALISC/FHS/J0 - WKLD COST REPORT BY MAJ SCTN; 2/6/91@16:04
 LRCAPML1 ;SLC/AM/DALISC/FHS/J0 - WKLD COST REP BY MAJ SCTN; 2/6/91@16:04
 LRCAPML2 ;SLC/AM/DALISC/FHS - WKLD COST REP BY MAJ SCTN; 2/6/91@16:04
 LRCAPML3 ;SLC/AM/DALISC/FHS - WKLD COST REP BY MAJ SCTN; 2/6/91@16:04
 LRCAPMR ;SLC/AM/DALISC/FHS/J0 - SETUP WORKLOAD REPORT PARAMETERS;7-MAR-1991
 14:58:24.12
 LRCAPMR1 ;DALISC/J0 - WKLD STATS REPORT - STD/QC/RPT/MAN PRINT ; 4/9/93
 LRCAPMR2 ;DALISC/J0 - WKLD STATS REPORT - COMMENTS PRINT ; 4/9/93
 LRCAPPH ;DALISC/FHS - PROCESS PHLEBOTOMY WORKLOAD DATA ; 09/28/93 13:04
 LRCAPR1 ;DALISC/PAC/FHS/JBM - WKLD REP GENERATOR-MAIN ;10/15/92 11:15
 LRCAPR1A ;DALISC/PAC/FHS/JBM - WKLD REP GENERATOR-SELECT ;10/15/92 11:15
 LRCAPR2 ;DALISC/PAC/FHS/JBM - WKLD REP GENERATOR-BUILD ;10/11/92 01:55
 LRCAPR3 ;DALISC/PAC/FHS/JBM - WKLD REP GENERATOR-PRINT 1 ;10/16/92 16:49
 LRCAPR3A ;DALISC/PAC/FHS/JBM - WKLD REP GENERATOR-PRINT 2 ;10/16/92 16:49
 LRCAPR4 ;DALISC/PAC/FHS/JBM - WKLD REP GENERATOR-UTILITIES ;10/16/92 16:49
 LRCAPS ;DALISC/FHS - REPLACEMENT RTN OF WKLD REP GENERATOR-MAIN ;10/15/92
 11:15
 LRCAPTS ;SLC/AM/DALISC/FHS - TREATING SPECIALITY WORKLOAD REPORT; 2/6/91@16:
 LRCAPTS1 ;SLC/AM/DALISC/FHS - PRINT TREATING SPECIALTY WKLD REPORT;
 2/6/91@16:04
 LRCAPU ;DALISC/J0 - LAB CAP UTILITIES ;3/17/93
 LRCAPV ;SLC/FHS - DETERMINE WKLD CODE AND STUFF INTO 68 ;2/19/91 11:45
 LRCAPV1 ;SLC/FHS - DETERMINE CAP AND STUFF INTO LRO(68 PART 1
 LRCAPV11 ;SLC/FHS - CREAT NEW WKLD CODES ADDED BY THE SITE
 LRCAPV1A ;SLC/FHS - SET NEW WKLD CODE INTO ^LAM
 LRCAPV1S ;SLC/FHS - SET WKLD CODE INTO LRO(68 PART 2
 LRCAPV2 ;SLC/AM/DALISC/FHS - STORE WORKLOAD FROM 68 INTO ^LRO(64.1 ;5/2/91
 09:03
 LRCAPV3 ;SLC/AM/DALISC/FHS - CONTINUE STORE OF CAP WORKLOAD TO 64.1
 LRCAPVM ;SLC/FHS - ADD WKLD CODES FOR MICRO VERIFICATION ;
 LRCE ;SLC/RWF/MILW/JMC - LOOK-UP ON CENTRAL ENTRY # ;2/5/91 11:29 ;
 LRCENDE1 ;SLC/CJS - ORDER DELETE ;2/5/91 12:23 ;
 LRCENDEL ;SLC/CJS - ORDER DELETE ;2/5/91 12:28 ;
 LRCHIV ;SLC/RWF - SET UP O("S") VARIABLES FOR ARCHIVE. ;2/5/91 12:30 ;

Routine Descriptions

LRCHIVD ;SLC/MRH/DALISC/FHS - DEARCHIVE FROM ^LAR TO ^LR ;2/5/91 12:31 ;
LRCHIVE ;SLC/RWF - REMOVE OLD DATA FROM PT. FILE ;8/10/89 11:11 ;
LRCHIVK ;SLC/RWF - REMOVE OLD LAB DATA ; 12/14/87 15:46 ;
LRCKF ;SLC/RWF - CHECK FILE FOR COHESIVENESS ; 8/30/87 17:19 ;
LRCKF60 ;SLC/RWF - CHECK FILE 60 ;4/4/89 20:36 ;
LRCKF62 ;SLC/RWF - CHECK FILE'S ACC TEST FILE ; 2/22/87 1:46 PM ;
LRCKF68 ;SLC/RWF - CHECK FILE 68 ; 8/27/87 10:32 ;
LRCKF69 ;SLC/RWF - CHECK FILE 69 ; 2/22/87 1:47 PM ;
LRCKFLA ;SLC/RWF - CHECK LOAD LIST & AUTO INSTRUMENT FILES ;2/5/91 12:32 ;
LRCKPTR ;SLC/RWF - CHECK ^LR & ^DPT CROSS POINTERS ; 8/30/87 17:20 ;
LRCONJAM ;SLC/CJS - JAM CONTROLS ONTO ACCESSION ;2/19/91 10:31 ;
LRCYPCT ;AVAMC/REG - CYTOPATH %POS,NEG,SUSP, & UNSAT ;9/16/93 08:09 ;
LRDATEDH ;DALISC/DRH - DATE RANGE FOR LRRS 1-14-94
LRDCOM ;SLC/BA - REPORT OF DELETED OR EDITED COMMENTS ;2/19/91 10:32 ;
LRDIED ;SLC/RWF - EDIT ; 8/5/87 10:38 ;
LRDIQ ;SF/GFT/DALISC/FHS - MODIFIED LAB VERSION OF CAPTIONED TEMPLATE
FILEMAN 19 ;1/10/92 10:23 AM
LRDIST ;SLC/CJS - DATA DISTRIBUTION ;2/20/91 10:09 ;
LRDIST1 ;SLC/CJS/MILW/JMC - DATA DISTRIBUTION ;2/5/91 13:00 ;
LRDIST2 ;SLC/DM - WRITE SUMMARY OF LEVY-JENNINGS LRQC CHART ;2/5/91 13:06 ;
LRDIST3 ;SLC/CJS - DATA DISTRIBUTION ; 2/22/87 1:53 PM ;
LRDIST4 ;SLC/DCM - GRAPH ENTRY FOR OE/RR ;12/6/90 18:32
LRDPA ;SLC/RWF/CJS - FILE OF FILES LOOKUP ON ENTITIES ;3/8/94 07:59 ; [
10/28/93 2:46 PM]
LRDPA1 ;AVAMC/REG - PT LOOKUP IN FILES FOR LAB ;3/28/94 10:55 ;
LRDPA2 ;AVAMC/REG - PT BLOOD BANK LOOKUP ;12/14/92 10:47 ;
LRDRAW ;SLC/CJS - WARD COLLECTION SUMMARY ;2/19/91 10:34 ;
LREV ;SLC/CJS - REVIEW OF LRTEST DESCRIPTIONS ;2/19/91 13:06 ;
LREXEC ;SLC/RWF - EXECUTE CODE EXPANSION ; 6/2/86 7:54 AM ;
LREXECU ;SLC/RWF - EXECUTE CODE UTILITY ; 3/31/88 3:54 PM ;
LREXPD ;SLC/RWF - EXPLODE A LRTEST LIST ;2/5/91 13:15 ;
LRFAC ;MILW/JMC/DALISC/FHS - CUM PRINT FOR FILEROOM PATIENTS TO SEPARATE
PRINTER
LRFASST ;SLC/CJS - FAST ENTRY ;2/5/91 13:15 ;10/07/93 08:16
LRFASST ;DALISC/FHS - ENHANCED LRFASST ROUTINE ACCESSION/VERIFY PROCESS
LRFLAG ;SLC/RWF - SEARCH ^LRO(68.2,INST,8, FOR FLAGED SAMP ;2/5/91 13:16 ;
LRFNDLOC ;SLC/CJS - RETURN A LOCATION FROM ^LRO(69,LRODT,1,"AR",LRLLOC,SN)
;2/8/91 08:42 ;
LRGEN ;SLC/RWF - GENERAL REPORT FOR SELECTED TESTS ;4/5/89 14:09 ;
LRGEN1 ;SLC/RWF - GENERAL DATA DISPLAY ;2/19/91 10:35 ;
LRGEN2 ;SLC/RWF - CUMULATIVE REPORT FOR SELECTED TESTS ; 8/25/87 08:35 ;
LRGP ;SLC/CJS/RWF - INSTRUMENT GROUP DELTA CHECK DISPLAY ;2/5/91 13:19 ;
LRGP1 ;SLC/CJS/RWF - COMMON PARTS TO INSTRUMENT GROUP VERIFY/CHECK ;2/5/91
13:21 ;
LRGP2 ;SLC/CJS/RWF - COMMON PARTS TO INSTRUMENT GROUP VERIFY/CHECK ;2/5/91
13:23 ;
LRGV ;SLC/RWF - INSTRUMENT GROUP VERIFY DATA ;2/5/91 13:26 ;
LRGV1 ;SLC/RWF - PART2 OF INSTRUMENT GROUP VERIFY DATA ;2/8/91 09:29 ;
LRGV2 ;SLC/RWF - PART2 OF INSTRUMENT GROUP VERIFY DATA ;2/8/91 09:36 ;
LRGVG2 ;SLC/RWF - VERIFY GENERAL DATA AS A GROUP,CONT. ; 2/22/87 2:00 PM ;
LRGVGK ;SLC/RWF - ROUTINE TO KILL A LIST OF VARIABLES ; 10/8/87 19:24 ;
LRGVK ;SLC/RWF - KILL OFF VARIABLES FROM LRV*,LRVER*,LRGV*,LRGP* ; 10/8/87
19:25 ;
LRGVK1 ;SLC/RWF - KILL OFF VARIABLES FROM LRTSTJAN ;10/10/90 11:11
LRGVP ;SLC/CJS - GROUP DATA REVIEW DISPLAY ;2/5/91 13:29 ;
LRHDR ;SLC/CJS - HEALTH DEPARTMENT REPORT ;2/19/91 10:37 ;
LRKILL ;SLC/CJS - CLEAN-UP AFTER LR ROUTINES ;7/28/89 17:27 ;
LRLABAR ;SLC/FHS - LABEL BAR CODE DOWN LOAD FORMAT

Routine Descriptions

```

LRLABEL    ;SLC/TGA - PRINTS STANDARD LABELS 3.5X15/16 ;2/6/91  08:18 ;
LRLABEL1   ;SLC/TGA - PRINTS LABELS 2X5 UNEVEN ;2/6/91  08:18 ;
LRLABEL2   ;SLC/TGA - PRINTS LABELS ORDER # FIRST ;2/6/91  08:17 ;
LRLABEL3   ;SLC/RWF - PRINTS MEDLAB LABELS ;2/6/91  08:06 ;
LRLABEL5   ;DUR/KT/AT - PRINTS ON VAF 10-1392 LABELS ;2/6/91  08:05 ;
LRLABEL6   ;SLC/FHS - BAR CODE LABELS FOR THE INTERMEC PRINTER
LRLABELA   ;SLC/RAF - INTERMEC 4100 2 LABEL PRINT BARCODE/PLAIN ;10/20/93  10:16
LRLABELB   ;SLC/JL/RAF - 10 PART LABELS FOR THE INTERMEC 4100 PRINTER
LRLABELF   ;SLC/CJS/DALISC/DRH - PRINT COLLECTION LIST (CONT.) ; 3/28/89  19:39 ;
LRLABLD    ;SLC/TGA - LABELS ON DEMAND ; 5/22/87  20:42 ;
LRLABLD0   ;DALISC/FHS/DRH - LABELS ON DEMAND FOR FUTURE LAB COLLECT
LRLABLDS   ;DALISC/FHS/DRH - PRINT SINGLE LABELS ON DEMAND FOR FUTURE LAB COLLECT
LRLABLIO   ;SLC/TGA - TESTS LABEL PRINTER ;8/8/89  11:17 ;
LRLABXOL   ;RVAMC/PLS/DALISC/FHS - REPRINT ACCESSION LABELS FOR ENTIRE ORDER ;
           5/19/93  07:40
LRLABXT    ;SLC/TGA - REPRINTS DEMAND LABELS ;2/19/91  10:38 ;
LRLAM      ;SLC/CJS - STUFF AMIS DATA INTO LAM GLOBAL ;2/5/91  14:18 ;
LRLIST     ;SLC/RWF/CJS - LAB RESULTS LIST ;2/19/91  10:39
LRLISTE    ;SLC/RWF/CJS/DALISC/FHS/JBM/DRH - LAB RESULTS LIST, EXTENDED ;2/19/91
           10:39
LRLLL      ;SLC/RWF - LOAD LIST CONTROL ;2/19/91  10:41 ;
LRLLL1     ;SLC/RWF - LOAD LIST SCAN. ;2/19/91  10:42 ;
LRLLL1A    ;SLC/RWF - LOAD LIST CONTROL ; 2/23/89  17:29 ;
LRLLL2     ;SLC/RWF - LOAD LIST BUILD ;2/6/91  07:45 ;
LRLLL3     ;SLC/RWF - LOAD LIST BUILD UTILITY ;2/5/91  14:34 ;
LRLLL4     ;SLC/RWF - LOAD LIST BUILD, CONT. (Control's) ;2/6/91  07:44 ;
LRLLLP     ;SLC/RWF - LOAD LIST PRINT ;2/19/91  10:43 ;
LRLLLP2    ;SLC/RWF - TRAY LIST PRINT ;2/5/91  14:37 ;
LRLLLP3    ;SLC/RWF/MILW/JMC - SEQUENCE LIST PRINT ;2/5/91  14:38 ;
LRLLLP4    ;SLC/RWF - SET UP DISPLAY ORDER FOR PRINT ;2/5/91  14:38 ;
LRLLLP5    ;SLC/RWA/MILW/JMC- EXPANDED TRAY LIST PRINT ;2/5/91  14:39 ;
LRLLS      ;SLC/RWF - LOAD LIST FIX UP ; 8/17/87  11:16 ;
LRLLS2     ;SLC/RWF/MILW/JMC- LOAD LIST FIX UP ;2/5/91  14:40 ;
LRLLS3     ;SLC/RWF - MORE LOAD/WORK LIST CODE ;2/5/91  14:41 ;
LRLLU      ;SLC/RWF - LOAD LIST UTILITY ; 6/2/86  8:10 AM ;
LRLS       ;SLC/BA- PREINIT FOR AMIS FILE ;2/5/91  14:48 ;
LRLSR      ;SLC/RWF - REPORT SORT UTILITY ;2/5/91  14:49 ;
LRLSTWRK   ;SLC/CJS/DALISC/DRH - BRIEF ACCESSION LIST ;2/19/91  10:44 ;
LRLSTWRL   ;SLC/CJS/DALISC/DRH - BRIEF ACCESSION LIST PART 2 ;2/6/91  07:41 ;
LRLTR      ;SLC/RWF - PRINT BIG LETTERS ; 10/6/87  11:56 ;
LRLTR2     ;SLC/DCM - SET-UP LETTERS ; 6/2/86  8:11 AM ;
LRMIBL     ;AVAMC/REG - BATCH ORDERING/ACCESSION LOGING ; 8/25/87  08:37 ;
LRMIBUG    ;AVAMC/REG,SLC/CJS,BA- DISPLAY ORGANISMS ;6/5/89  09:21 ;
LRMIEDZ    ;AVAMC/REG/SLC/CJS/BA - MICROBIOLOGY EDIT ROUTINE ;4/24/89  14:35 ;
LRMIEDZ2   ;SLC/CJS/BA,AVAMC/REG - MICROBIOLOGY EDIT ROUTINE ; 2/22/89  11:16 ;
LRMIEDZ3   ;SLC/CJS/BA - MICROBIOLOGY EDIT ROUTINE CONT. ; 7/21/87  11:01 ;
LRMIEDZ4   ;DALISC/FHS - CONTINU MICROBIOLOGY EDIT ;3/24/92
LRMIHDR    ;SLC/CJS/BA - HEALTH DEPARTMENT REPORT ;2/19/91  10:46 ;
LRMILL     ;SLC/DLG - BUILD LOAD LIST FOR MICROSCAN ;4/4/89  21:38 ;
LRMINEW    ;SLC/CJS/BA - NEW DATA TO BE REVIEWED/VERIFIED ;4/24/89  14:36 ;
LRMINEW1   ;SLC/CJS/BA - NEW DATA TO BE REVIEWED/VERIFIED ; 11/23/87  16:34 ;
LRMINEW2   ;SLC/CJS/BA - NEW DATA TO BE REVIEWED/VERIFIED ;2/19/91  10:49 ;
LRMIPC     ;SLC/CJS/BA - MICROBIOLOGY CUMULATIVE PATIENT REPORT ;2/19/91 10:51 ;
LRMIPLG    ;SLC/CJS/BA - PRINT BY LOG NUMBER ;2/19/91  10:53 ;
LRMIPSU    ;AVAMC/REG/SLC/CJS/BA - MICRO PATIENT REPORT ; 10/7/87  08:42 ;
LRMIPSZ    ;AVAMC/REG/SLC/CJS/BA - MICRO PRINT/SINGLE SPECIMEN REPORT ;2/19/91
           10:55 ;
LRMIPSZ1   ;AVAMC/REG/SLC/CJS/BA - MICRO PATIENT REPORT ;2/19/91  10:57 ;

```

Routine Descriptions

LRMIPSZ2 ;AVAMC/REG/SLC/CJS/BA - MICRO PATIENT REPORT - BACTERIA, SIC/SBC, MIC
;3/28/90 15:23 ;

LRMIPSZ3 ;SLC/CJS/BA- MICRO PATIENT REPORT - STERILITY, PARASITES, VIRUS ;
6/22/87 16:15 ;

LRMIPSZ4 ;SLC/CJS/BA - MICRO PATIENT REPORT - AFB, FUNGUS ; 6/22/87 16:17 ;

LRMIPSZ5 ;AVAMC/REG/SLC/CJS/BA - MICRO PATIENT REPORT - BACTERIA, ANTIBIOTICS ;
10/24/88 16:18 ;

LRMIS ;AVAMC/REG - DELETE MICROBIOLOGY AUDITS ;4/26/89 14:38

LRMISEZ ;AVAMC/REG/SLC/BA - MICROBIOLOGY INFECTION CONTROL DATA ; 2/14/89
17:10 ;

LRMISEZ1 ;AVAMC/REG/SLC/BA - MICROBIOLOGY INFECTION CONTROL DATA;4/17/91 14:29;

LRMISEZ2 ;AVAMC/REG/SLC/BA - MICRO INFECTION CTRL SURVEY ; 10/1/87 17:12 ;

LRMISEZ3 ;AVAMC/REG/SLC/BA - MICRO INF CTRL SURVEY CONT'D ; 10/1/87 17:15 ;

LRMISEZ4 ;AVAMC/REG/SLC/BA - MICRO INF CTRL SURVEY COND'T; 3/28/87 6:41 PM ;

LRMISEZA ;AVAMC/REG/SLC/BA - MICROBIOLOGY INF CONTROL DATA ; 10/9/87 16:18 ;

LRMISEZB ;AVAMC/REG/SLC/BA - MICROBIOLOGY INFECTION CONTROL DATA ; 7/11/87
01:50 ;

LRMISR ;SLC/CJS/BA - INPUT TRANSFORM FOR ANTIBIOTIC SENSITIVITIES ;6/14/89
08:36 ;

LRMISR1 ;SLC/BA - INPUT TRANSFORM FOR ANTIBIOTIC SENSITIVITIES; 7/14/87 09:34;

LRMISTF ;SLC/CJS/BA - MASS DATA ENTRY INTO FILE 63.05 ;4/24/89 14:40 ;

LRMISTF1 ;SLC/CJS/BA - MASS DATA ENTRY INTO FILE 63.05 ; 11/23/87 17:24 ;

LRMITS ;SLC/STAFF - MICRO TREND ;10/14/92 15:59

LRMITSE ;SLC/STAFF - MICRO TREND ENTRY ;3/4/93 17:07

LRMITSEC ;SLC/STAFF - MICRO TREND ENTRY COMPREHENSIVE ;10/19/92 10:08

LRMITSES ;SLC/STAFF - MICRO TREND ENTRY SELECTIONS ;10/18/92 16:03

LRMITSP ;SLC/STAFF - MICRO TREND PROCESS ;3/4/93 16:59

LRMITSPC ;SLC/STAFF - MICRO TREND PROCESS COUNT ;10/17/92 23:16

LRMITSPE ;SLC/STAFF - MICRO TREND PROCESS EXTRACT ;10/28/93 15:17

LRMITSPO ;SLC/STAFF - MICRO TREND PROCESS ORGANISMS ;3/4/93 14:54

LRMITSPS ;SLC/STAFF - MICRO TREND PROCESS SETUP ;10/12/92 20:07

LRMITSR ;SLC/STAFF - MICRO TREND REPORT ;10/17/92 22:52

LRMITSRH ;SLC/STAFF - MICRO TREND REPORT HEADER ;10/12/92 20:26

LRMITSRS ;SLC/STAFF - MICRO TREND REPORT SETUP ;11/7/93 12:33

LRMIU4 ;SLC/RWF,BA - READ MICRO ACCESSION ; 2/27/89 08:33 ;

LRMIUT ;SLC/CJS/BA/AVAMC/REG - MICROBIOLOGY UTILITIES ; 10/9/87 16:19 ;

LRMIUT1 ;SLC/BA/MILW/JMC - INPUT TRANSFORMS FOR MICRO ; 4/5/88 4:54 PM ;

LRMIV ;SLC/DLG - MICROBIOLOGY VERIFY AUTO INST ROUTINE ;4/24/89 14:41 ;

LRMIV1 ;SLC/DLG - LAB ROUTINE DATA VERIFICATION ;2/6/91 08:21 ;

LRMIV2 ;SLC/DLG - MICROBIOLOGY VERIFY AUTO INST ROUTINE ; 12/6/88 17:28 ;

LRMIV3 ;SLC/DLG - MICROBIOLOGY VERIFY AUTO INST ROUTINE CONT.;9/9/88 1:03 PM;

LRMIV4 ;SLC/DLG - MICRO DISPLAY ANTIBIOTICS FOR VERIFY ; 12/8/88 23:02 ;

LRMIVER ;SLC/CJS/BA - MICROBIOLOGY CHART COPY APPROVAL ;4/24/89 14:42 ;

LRMIVER1 ;SLC/CJS/BA- MICRO CHART COPY APPROVAL CONT. ;2/19/91 11:01 ;

LRMIXALL ;DALISC/FHS - RE INDEX "AI" "AJ" "AS" FOR ^LAB(62.06

LRMIXPD ;SLC/BA - LAB DESCRIPTIONS ;2/6/91 08:23 ;

LRMIXR1 ;SLC/BA - X-REF FOR ANTIBIOTIC INTERPRETATION ^LAB(62.06,"AJ") ;
8/5/87 10:40 ;

LRMIXR2 ;SLC/BA - X-REF FOR DISPLAY SCREEN ^LAB(62.06,"AS",; 8/5/87 10:40 ;

LRMIXR3 ;SLC/BA - ANTIBIOTIC INTERPRETATION ^LAB(62.06,"AI", X-REF ; 4/4/87
21:05 ;

LRMIZAP ;SLC/BA - MICRO CONVERSION ; 8/5/87 18:18 ;

LRMIZAP1 ;SLC/BA - MICRO CONVERSION ; 4/4/87 21:05 ;

LRMRSHRT ;SLC/CJS - MULTI-RULE SHEWHART QUALITY CONTROL ;2/6/91 08:35 ;

LRNDLST ;SLC/CJS - PRINT LIST OF NON-DRAW ORDERS ;2/19/91 11:03 ;

LRNIGHT ;SLC/CJS/AVAMC/REG - NIGHTLY LAB CLEANUP ;6/5/90 21:08 ;

LRNIGHT1 ;SLC/DCM - NIGHTLY LAB CLEANUP (^LAM,^LRO(67.9) ;2/6/91 08:47 ;

LRNIGHT2 ;AVAMC/REG - STUFF CAP DATA INTO LAM GLOBAL ;2/6/91 08:48 ;

Routine Descriptions

```

LRNITEG      ;SLC/FHS - INTEGRITY CHECKER FOR LAB SERVICE PACKAGE;8/3/89  17:52 ;
LRNITEGL     ;SLC/FHS - LOAD INTERGRITY FILE 69.91 ; 4/7/89  00:05 ;
LRNODRAW     ;SLC/CJS - PRINT LIST OF NON-DRAW ORDERS ;2/19/91  11:04 ;
LRNORMAL     ;SLC/RWF - TO RETURN TEST NORMALS ;2/6/91   08:54 ;
LRNPXA       ;SLC/MRH/FHS - NEW PERSON CONVERSION FOR ^LAR("Z" ; 1/23/93
LRNPXA0      ;SLC/MRH/FHS/J0 - NEW PERSON CONVERSION FOR ^LAR("Z" ; 1/23/93
LRNPXA1      ;SLC/MRH/FHS/JB0 - NEW PERSON CONVERSION FOR ^LAR("Z" ; 1/23/93
LRNUM        ;SLC/BA - NUMERIC INPUT TRANSFORM ;2/6/91   08:55 ;
LRO          ;SLC/DCM - Being replaced ;1/10/91  16:0 ;
LRO1         ;SLC/DCM - Being replaced ; 3/9/89  19:39 ;
LRO2         ;SLC/DCM - Being replaced ;1/10/91  16:01 ;
LRO3         ;SLC/DCM - Being replaced ; 7/3/89  15:07 ;
LRO4         ;SLC/DCM - Being replaced ;1/31/91  08:46 ;
LRO5         ;SLC/DCM - Being replaced ;1/10/91  16:01 ;
LRO6         ;SLC/DCM - Being replaced ; 2/14/89  18:07 ;
LRO7         ;SLC/DCM - Being replaced ;1/9/91   17:32 ;
LRO8         ;SLC/DCM - Being replaced ;1/10/91  16:0 ;
LROC         ;SLC/CJS - ORDER LIST CLEAN-UP ;2/6/91  10:46 ;
LROC1        ;SLC/CJS - TO CLEAN UP LAB ANCILLARY FILE ;2/6/91  10:53 ;
LROCM        ;SLC/FHS - WARNING MESSAGE ORDER LIST CLEAN-UP ;8/8/89  07:48
LROE         ;SLC/CJS - LAB ORDER ENTRY AND ACCESSION ;2/6/91  09:25 ;
LROE1        ;SLC/CJS - MORE ORDER ENTRY ;6/24/91  10:52 ;
LROE2        ;DALISC/FHS - CONTINUED MORE ORDER ENTRY ;3/24/92
LROI         ;SLC/CJS - LAB ORDER INFORMATION UPDATE ; 8/25/87  08:46 ;
LROLOVER     ;SLC/CJS - ROLL OVER DAILY LAB ACCESSION NUMBERS ;2/19/91  11:07 ;
LROPT        ;SLC/BA- HELP FRAME INFO ON LAB OPTIONS ;2/19/91  11:09 ;
LROPTLST     ;SLC/FHS - LIST OPTIONS FOR VERIFICATION ;2/19/91  11:10 ;
LROR         ;SLC/CJS - LAB MODULE FOR OR ;3/29/90  16:39 ;
LROR1        ;SLC/DCM - LAB MODULE FOR OR (CONT.) ; 3/29/89  10:09 ;
LROR2        ;SLC/BA,DCM - PRINT THE DATA FOR OR REPORTS ;3/29/90  16:43 ;
LROR3        ;SLC/DCM - CANCEL,PURGE,SETUP,CLEAN EXECUTES ;11/26/90  10:10 ;
LROR4        ;SLC/DCM - MICRO DETAILED DISPLAY ON ORDERS ;4/17/91  14:29 ;
LROR4A       ;AVAMC/REG/SLC/CJS/BA - MICRO PATIENT REPORT - BACTERIA, SIC/SBC, MIC
              ; 3/16/88  2:41 PM ;
LROR4B       ;AVAMC/REG/SLC/CJS/BA - MICRO PATIENT REPORT - BACTERIA, ANTIBIOTICS ;
              3/16/88  3:47 PM ;
LROR5        ;SLC/CJS - LAB MODULE FOR OR ; 12/5/88  09:34 ;
LROR6        ;SLC/DCM - EDIT LAB ORDERS FOR OE/RR ;9/11/89  16:55 ;
LROR6A       ;SLC/DCM - EDIT UNRELEASED LAB ORDERS FOR OE/RR ;9/11/89  16:55 ;
LROR6B       ;SLC/DCM/RWA - EDIT UNRELEASED LAB ORDERS FOR OE/RR CONT;9/11/89 16:55;
LROR7        ;SLC/DCM - RENEW LAB ORDERS ;5/1/89  17:51 ;
LROR8        ;SLC/DCM - FLAG/HOLD ORDERS ;5/1/89  17:46 ;
LROR9        ;SLC/DCM - ADD TESTS TO AN EXISTING ORDER THRU OE/RR; 9/23/88  15:15
              ;2/8/91  07:29 ;
LRORD        ;SLC/CJS - LAZY ACCESSION LOGGING ;2/6/91  12:54 ;
LRORD1       ;SLC/RWF - LAZY ACCESSION LOGGING ;2/6/91  13:11 ;
LRORD2       ;SLC/CJS - MORE OF LAZY ACCESSION LOGGING ;2/6/91  12:57 ;
LRORD2A      ;SLC/FHS - CHECK FOR MAX FREQ OF ORDERS ;2/6/91  13:00
LRORD3       ;SLC/CJS - MORE LAZY ACCESSION LOGGING ;2/6/91  13:01 ;
LRORDD       ;SLC/FHS - CHECK FOR DIFFERENT URGENCY WITH IN ORDER ;2/6/91 13:05 ;
LRORDERN     ;SLC/CJS - DETERMINE NEXT LRORDER NUMBER ; 6/2/86  8:33 AM ;
LRORDIM      ;DALISC/FHS - PROCESS IMMEDIATE LAB COLLECT ALLOWABLE COLLETCTION
              TIMES
LRORDK       ;SLC/FHS - CLEAN UP AFTER ACCESSIONING PROCESS ;8/7/89  13:58
LRORDST      ;SLC/CJS/RWF - SET THE ORDER AND ACCESSION ;2/6/91  13:17 ;
LRORDST1     ;SLC/CJS/RWF - Being replaced ;3/29/90  16:40 ;
LROS         ;SLC/CJS - LAB ORDER STATUS ;2/6/91  13:26 ;
LROSPLG      ;B'HAM ISC/ADM - MOVE SP DATA FROM SURGICAL RECORD ;4/12/94  08:54

```

Routine Descriptions

LROSPLG1 ;B'HAM ISC/ADM - STATUS OF SURGICAL CASE ;4/12/94 08:55
LROSPLG2 ;B'HAM ISC/ADM - COPY INFO FROM OPERATION RECORD; 09 AUG 1993 9:57 AM
;4/12/94 08:56
LROX0 ;SLC/DCM - Being replaced ;1/29/91 14:44
LROX1 ;SLC/DCM - Being replaced ;7/17/90 12:17
LROW ;SLC/CJS - LAB ORDER ENTRY, WARD ;2/6/91 13:30 ;
LROW1 ;SLC/CJS - TEST & SAMP ;2/6/91 13:32 ;
LROW1A ;SLC/CJS - TEST & SAMP CONTINUED FROM LROW1; 12/12/88 18:48 ;8/30/89
10:48
LROW2 ;SLC/CJS - TEST & SAMPLE VERIFICATION ;2/6/91 13:49 ;
LROW2A ;SLC/FHS - CONTINUING TEST & SAMPLE VERIFICATION; ;2/6/91 13:50
LROW2P ;SLC/TGA - PRINTS WARD COLLECT ORDER IN LAB ;2/19/91 11:11 ;
LROW2RP ;SLC/RWA - OPTION TO REPRINT A ORDER ;2/6/91 13:55 ;
LROW3 ;SLC/CJS/MILW/JMC - LIST THE TESTS ORDERED AND ALLOW EDITING ;2/6/91
13:57 ;
LROW4 ;SLC/CJS - LAB ORDER ENTRY, WARD (CONT.) ;7/28/89 20:08 ;
LROW5 ;SLC/CJS - LAB ORDER ENTRY, WARD ;2/6/91 13:59 ;
LRPARAM ;SLC/CJS/DALISC/FHS - SET LAB PARAMETERS ;2/6/91 14:25 ;
LRPHXPT ;SLC/CJS/RWF - EXCEPTION LOGIN OF ACCESSIONS ; 8/3/87 16:01 ;
LRPHITE1 ;SLC/CJS - LRPHITEM, CONT. ; 7/19/88 12:15 ;
LRPHITE2 ;SLC/CJS - LRPHITEM CONT. ; 2/23/88 10:44 ;
LRPHITE3 ;SLC/CJS/RWF- ITEMIZED LOGIN ; 9/8/87 12:39 ;
LRPHITEM ;SLC/CJS/RWF- ITEMIZED LOGIN ;6/24/91 10:49 ;
LRPHLIS1 ;SLC/CJS - PRINT COLLECTION LIST (CONT.) ; 3/28/89 19:39 ;
LRPHLIST ;SLC/CJS - PRINT COLLECTION LIST ;2/19/91 11:13 ;
LRPHSET ;SLC/CJS - COLLECTION LIST TO ACCESSIONS ;2/19/91 11:16 ;
LRPHSET1 ;SLC/CJS - COLLECTION LIST TO ACCESSIONS ;7/11/90 11:50 ;
LRPHSET2 ;SLC/RWA - COLLECTION LIST TO ACCESSIONS CONT ;
LRQC ;SLC/CJS - QUALITY CONTROL DISPLAY ; 6/2/86 8:38 AM ;
LRQCC ;SLC/CJS - QUALITY CONTROL FOR BULL ALGORITHM ;2/6/91 14:28 ;
LRQCLOG ;SLC/CJS - QUALITY CONTROL LOGGING ;3/28/90 15:20 ;
LRRD ;SLC/DCM/BA - INTERIM REPORT BY PHYSICIAN ;2/19/91 11:33 ;
LRRK ;SLC/BA - INTERIM REPORT CLEANUP ; 3/16/88 8:00 PM ;
LRRP ;SLC/RWF/BA - PROCESS DATA FOR INTERIM REPORTS ; 11/10/88 08:48 ;
LRRP1 ;SLC/RWF/BA - PRINT THE DATA FOR INTERIM REPORTS ; 11/9/88 17:31 ;
LRRP2 ;SLC/RWF - INTERIM REPORT ;10/24/91 09:58 ;
LRRP3 ;SLC/RWF/BA - INTERIM REPORT FOR SELECTED TESTS ;2/19/91 11:38 ;
LRRP4 ;SLC/DCM - INTERIM REPORT FOR OE/RR PATIENT LISTS ;12/10/90 13:39
LRRP5 ;DALISC/JBM - COLLECTION REPORT ;10/20/92
LRRP5A ;DALISC/JBM - COLLECTION REPORT-PRINT ;10/20/92
LRRP6 ;DALISC/J0 - LAB TEST/WORKLOAD CODE REPORTS ;12/07/92
LRRP6A1 ;DALISC/J0 - LAB TEST SUMMARY REPORT-BUILD ;11/27/92
LRRP6A2 ;DALISC/J0 - LAB TEST SUMMARY REPORT-CONDENSED ;11/27/92
LRRP6A3 ;DALISC/J0 - LAB TEST SUMMARY REPORT-DETAILED ;12/08/92
LRRP6B1 ;DALISC/J0 - WORKLOAD CODE SUMMARY REPORT-BUILD ;11/27/92
LRRP6B2 ;DALISC/J0 - WORKLOAD CODE SUMMARY REPORT-CONDENSED ;11/27/92
LRRP6B3 ;DALISC/J0 - WORKLOAD CODE SUMMARY REPORT-DETAILED ;12/08/92
LRRP7 ;DALISC/J0 - MANUAL WKLD STATS REPORT ; 5/19/93
LRRP8 ;DALISC/TNN/J0 - WKLD STATS REPORT BY SHIFT ; 4/9/93
LRRP8A ;DALISC/TNN/J0 - WKLD STATS REPORT BY SHIFT ; 4/9/93
LRRP8B ;DALISC/TNN/J0 - WKLD STATS REPORT BY SHIFT ; 4/9/93
LRRP8C ;DALISC/TNN/J0 - WKLD STATS REPORT BY SHIFT ; 4/9/93
LRRS ;SLC/DCM/BA/DALISC/FHS - INTERIM REPORT BY LOCATION (MANUAL QUEUE)
;2/19/91 11:39 ;
LRRS12 ;SLC/DCM,BA/DALISC/FHS/DRH - INTERIM REPORT BY LOCATION (MANUAL QUEUE)
;2/19/91 11:39 ;
LRRS13 ;SLC/DCM,BA/DALISC/FHS/DRH - INTERIM REPORT BY LOCATION (MANUAL QUEUE)
;2/19/91 11:39 ;

Routine Descriptions

```

LRRSP      ;SLC/RWF/BA - INTERIM REPORT FOR SELECTED TESTS AS ORDERED ;2/19/91
11:41 ;
LRSETUP    ;SLC/CJS/DALISC/FHS - REINITIALIZE DATA FILES ;2/6/91 14:34 ;
LRSLOW     ;SLC/CJS/DALISC/FHS - MODIFIED FAST ENTRY ;2/5/91 13:15 ;
LRSMAC     ;SLC/RWF - CHEM. LAB SMAC REPORT ;2/19/91 13:08 ;
LRSOR      ;SLC/RWF/CJS - SOME SPECIAL OUTPUT ROUTINES ;2/6/91 15:19 ;
LRSOR1     ;SLC/RWF/CJS - SOME SPECIAL OUTPUT ROUTINES ;6/2/86 8:43 AM ;
LRSORA     ;DRH/DALISC - HIGH/LOW VALUE REPORT ;2/19/91 11:42 ;
LRSORA0    ;DRH/DALISC - Continuation of LRSORA 07-28-93
LRSORA1    ;SLC/KCM - CREATE SEARCH LOGIC ;8/5/87 11:40 ;
LRSORA2    ;SLC/KCM/DALISC/DRH - SEARCH LAB DATA AND PRINT REPORT ;8/28/89 12:07;
LRSORA3    ;SLC/KCM - SEARCH LAB DATA AND PRINT REPORT ;8/28/89 12:07 ;
LRSORB     ;SLC/RWF - SCAN PART OF LRSORA ;7/3/86 12:47 PM ;
LRSORC     ;SLC/RWF/DALISC/JBM - CRITICAL VALUE REPORT ;8/30/87 17:25 ;
LRSORC1    ;SLC/RWF/DALISC/JBM - CRITICAL VALUE REPORT ;8/30/87 17:25 ;
LRSORC1A   ;DALISC/DRH - LRSORC Continued ;07-22-93
LRSORD     ;SLC/RWF/DALISC/JBM - CRITICAL VALUE REPORT ;8/30/87 17:25 ;
LRSORD1    ;SLC/RWF/DALISC/JBM- CRITICAL VALUE REPORT ;8/30/87 17:25 ;
LRSORD1A   ;DALISC/DRH - LRSORC Continued ;07-22-93
LRSPDA     ;AVAMC/REG - SURGICAL PATH DATA ENTRY ;9/11/88 17:13 ;
LRSPGD     ;AVAMC/REG - ANATOMIC PATH DESCRIPTION ;2/24/94 09:45 ;
LRSPRPT    ;AVAMC/REG - CY/EM/SP PATIENT RPT ;1/4/94 08:55 ;
LRSPRPT1   ;AVAMC/REG - SURG PATH RPT PRINT CONT. ;7/15/93 15:19 ;
LRSPRPT2   ;AVAMC/REG - SURG PATH PRINT SNOMED ;7/15/93 15:20 ;
LRSPRPTM   ;AVAMC/REG - MODIFIED PATH REPORT ;7/18/93 08:38 ;
LRSPS      ;AVAMC/REG - CY/EM/SP PATH SEARCH LROPT SELECTOR;6/24/86 12:21 PM ;
LRSPSICD   ;AVAMC/REG - CY/EM/SP ICD SEARCH ;3/9/94 13:26 ;
LRSPSICP   ;AVAMC/REG - SEARCH BY ICD CODE PRINT ;9/14/89 19:05 ;
LRSPPT     ;AVAMC/REG - AP PRELIMINARY REPORTS ;9/1/93 12:27 ;
LRSTATUS   ;SLC/FHS - TO CHECK SYSTEM STATUS OF AUTO INSTRUMENT JOBS ;11/6/89
12:03
LRSTOPC    ;DALISC/FHS - MANUALLY RECORD CLINIC STOP CODES FOR LAB
LRSTUF     ;SLC/CJS - MASS DATA ENTRY INTO FILE 63.04 ;10/8/87 19:28 ;
LRSTUF1    ;SLC/CJS - MASS DATA ENTRY INTO FILE 63.04 ;2/6/91 15:47 ;
LRSTUF2    ;SLC/CJS - MASS DATA ENTRY INTO FILE 63.04 ;2/6/91 15:49 ;
LRU        ;AVAMC/REG - LAB UTILITY ;4/22/94 13:05 ;
LRUA       ;AVAMC/REG - ANAT PATH UTILITY ;7/15/93 15:37 ;
LRUB       ;AVAMC/REG - GET 62.5 ENTRIES ;11/12/88 07:45 ;
LRUBL      ;AVAMC/REG - FIND PATIENT MISMATCHES ;2/18/93 13:24
LRUC       ;AVAMC/REG - GET PATIENT LOCATION ;7/25/89 21:21 ;
LRUCE      ;AVAMC/REG - LAB COMMENT EDIT ;6/2/86 9:03 AM ;
LRUCLR     ;SLC/CJS/AVAMC/REG - CLEAN UP WORKLIST FILE ;11/12/88 07:55 ;
LRUCN      ;AVAMC/REG - LAB CONSULTS ;2/18/93 12:34 ;
LRUCNBB    ;AVAMC/REG - COOMBS/ANTIBODY REPORT ;02/12/89 12:30 ;
LRUD       ;AVAMC/REG - STUFF DATA CHANGES ;1/14/91 10:58 ;
LRUD1      ;AVAMC/REG - STUFF DATA CHANGE IN COMMENT FIELD ;1/14/91 09:44
LRUDEL     ;AVAMC/REG - DELETE AN AP ACCESSION NUMBER ;6/12/93 09:13 ;
LRUDIT     ;AVAMC/REG - DATA CHANGE AUDIT ;4/19/89 14:25 ;
LRUDPT     ;AVAMC/REG - POW PTS ;2/18/93 12:36 ;
LRUE       ;AVAMC/REG - RESULTS FOR SELECTED LAB TESTS ;3/3/94 12:11 ;
LRUER      ;AVAMC/REG - ERROR TRACKING ;2/22/94 07:03 ;
LRUET      ;AVAMC/REG - RESULTS FOR A TEST RANGE ;2/18/93 12:43 ;
LRUFILE    ;AVAMC/REG - FILE OUTLINE ;2/18/93 12:46 ;
LRUG       ;AVAMC/REG - GET LRDFN ;8/23/93 09:18 ;
LRUL       ;AVAMC/REG - PATIENT UTILITY LIST ;6/14/92 11:03
LRULA      ;AVAMC/REG - EDIT LOCATION ;3/9/94 13:28 ;
LRULB      ;AVAMC/REG - LAB LOG-BOOK ;2/18/93 12:48 ;
LRULB1     ;AVAMC/REG - LAB LOG-BOOK CONT. ;3/3/94 14:28 ;

```

Routine Descriptions

LRULEN ;AVAMC/REG - BYTE COUNT FOR ACCESSIONS ;5/9/91 18:19 ;
 LRUMD ;AVAMC/REG - MD SELECTED LAB RESULTS ;3/10/94 09:13 ;
 LRUMD1 ;AVAMC/REG - MD SELECTED TESTS/PATIENTS ;6/16/93 13:24 ;
 LRUMD2 ;AVAMC/REG - MD SELECTED TESTS/PATIENTS ;2/18/93 12:57 ;
 LRUMDF ;AVAMC/REG - DEFAULT TEST LIST ;8/11/93 17:51 ;
 LRUMDM ;AVAMC/REG - MD SELECTED LAB RESULTS ;8/24/93 15:01 ;
 LRUMDP ;AVAMC/REG - MD SELECTED LAB RESULTS ;3/10/94 09:16 ;
 LRUMDS ;AVAMC/REG - MD SELECTED PATIENT GROUPS ;10/15/91 19:22 ;
 LRUMDU ;AVAMC/REG - MD SELECTED TEST UTILITY ;1/21/94 08:17 ;
 LRUMDU1 ;AVAMC/REG - MD SELECTED TEST UTILITY ;2/18/93 13:01 ;
 LRUMI ;AVAMC/REG - MICRO RREJECTED SPECIMEN REPORT ;10/6/93 11:52 ;
 LRUMSG ;AVAMC/REG - SEND SPECIAL MESSAGE ;12/14/88 09:16 ;
 LRUP ;AVAMC/REG - GET PARENT FILE DATA ;5/2/88 18:23 ;
 LRUPA ;AVAMC/REG - LAB ACCESSION LIST:DATE & TEST ;3/3/94 09:42 ;
 LRUPA1 ;AVAMC/REG - LAB ACCESSION LIST COND'T ;3/3/94 10:07 ;
 LRUPA2 ;AVAMC/REG - LAB ACCESSION LIST BY PAT ;2/18/93 13:07 ;
 LRUPAC ;AVAMC/REG - LAB ACCESSION COUNTS BY DATE ;2/18/93 13:08 ;
 LRUPACA ;AVAMC/REG - LAB ACC COUNTS BY LOC ;2/18/93 13:09 ;
 LRUPACS ;AVAMC/REG - LAB ACCESSION COUNTS BY SHIFT ;2/18/93 13:09 ;
 LRUPACT ;AVAMC/REG - LAB ACC COUNTS BY TREATING SPECIALTY ;9/30/93 11:57 ;
 LRUPAD ;AVAMC/REG - LAB ACCESSION LIST BY DATE ;3/3/94 10:38 ;
 LRUPAD1 ;AVAMC/REG - LAB ACCESSION LIST COND'T ;3/3/94 10:40 ;
 LRUPAD2 ;AVAMC/REG - LAB ACCESSION LIST BY PATIENT ;2/18/93 13:11 ;
 LRUPQ ;AVAMC/REG - LAB RESULTS BY ACCESSION AREA ;2/18/93 13:12 ;
 LRUPQ1 ;AVAMC/REG - LAB RESULTS BY ACCESSION AREA (COND'T) ;3/8/94 09:03 ;
 LRUPS ;AVAMC/REG - PATIENT SPEC LOOK-UP ;8/5/91 13:42 ;
 LRUPT ;AVAMC/REG - PATIENT TESTS ORDERED BY DATE ;3/4/93 11:23 ;
 LRUPUM ;AVAMC/REG - USER MANUAL ;3/9/94 13:31 ;
 LRUQ ;AVAMC/REG - CHECK FOR BAD POINTERS TO LAB FILE ;2/18/93 13:13 ;
 LRUR ;AVAMC/REG - LAB TEST COUNTS BY SPECIMEN ;2/18/93 13:14 ;
 LRURG ;AVAMC/REG - TRANSFER ROUTINES ;5/5/91 06:51 ;
 LRUSE ;AVAMC/REG - ENTER/EDIT SNOMED FIELDS ;6/2/86 9:12 AM ;
 LRUSET ;AVAMC/REG - RELEASE REPORTS ;8/5/87 10:43 ;
 LRUSNOM ;AVAMC/REG - ANATOMIC PATH REFERENCES ;4/12/94 10:15 ;
 LRUSP ;AVAMC/REG - ADD/DELETE SPECIAL STAIN ;10/9/87 16:26 ;
 LRUT ;AVAMC/REG - TIME DIFFERENCES ;8/22/88 21:0 ;
 LRUTA ;AVAMC/REG - DISPLAY LAB TEST INFO FOR LAB ;2/14/89 17:18 ;
 LRUTAD ;AVAMC/REG - ADD/DELETE LAB TEST/PROCEDURE ;11/12/88 09:34 ;
 LRUTELL ;AVAMC/REG - FIND EXISTING ACCESSION NUMBER ;6/2/86 9:13 AM ;
 LRUTL ;AVAMC/REG - GENERAL LAB UTILITY ;6/21/93 09:25 ;
 LRUTRAN ;AVAMC/REG - TRANSFER ^LR(LRDF,LRSS, TO ^LR(LRDFN#2,LRSS, ;5/9/91
 18:24 ;
 LRUTT ;AVAMC/REG - LAB TEST TURNAROUND TIME; 12/23/88 12:45 ;6/12/93 12:22 ;
 LRUTW ;AVAMC/REG - DISPLAY LAB TEST INFO FOR LAB ;2/14/89 17:19 ;
 LRUU ;AVAMC/REG - FIND FIELD FOR A SUBSCRIPT & PIECE ;9/2/87 09:35 ;
 LRUV ;AVAMC/REG - EDIT REF FILE ;3/9/94 13:38 ;
 LRUW ;AVAMC/REG - ACCESSION AREA WORKLIST ;2/22/94 07:21 ;
 LRUWG ;AVAMC/REG - SINGLE TEST WORKLIST ;2/22/94 09:45 ;
 LRUWK ;REG/AVAMC - WORKLOAD UTILITY ;8/20/93 06:57 ;
 LRUWL ;AVAMC/REG - DISPLAY WORKLOAD FOR ACCESSION ;3/9/94 13:40 ;
 LRUWLF ;AVAMC/REG - FILE #68 UTILITY ;3/28/91 16:07 ;
 LRVER ;SLC/CJS - LAB ROUTINE DATA VERIFICATION ;6/24/91 15:45 ;
 LRVER1 ;SLC/CJS - LAB ROUTINE DATA VERIFICATION ;2/7/91 15:19 ;
 LRVER2 ;SLC/CJS - LAB ROUTINE DATA VERIFICATION ;2/7/91 11:36 ;
 LRVER3 ;SLC/CJS - DATA VERIFICATION ;2/7/91 11:43 ;
 LRVER3A ;SLC/CJS - DATA VERIFICATION ;2/7/91 11:46 ;
 LRVER4 ;SLC/CJS - LAB ROUTINE DATA VERIFICATION ;2/7/91 12:03 ;
 LRVER5 ;SLC/CJS - LAB ROUTINE DATA VERIFICATION ;2/7/91 12:04 ;

Routine Descriptions

LRVR ;SLC/CJS - LAB ROUTINE DATA VERIFICATION ;3/28/90 17:06 ;
LRVR1 ;SLC/CJS - LAB ROUTINE DATA VERIFICATION ;3/28/90 17:14 ;
LRVR2 ;SLC/CJS - LAB ROUTINE DATA VERIFICATION ; 10/9/87 16:29 ;
LRVR3 ;SLC/CJS - LAB ROUTINE DATA VERIFICATION ; 11/17/88 16:17 ;
LRVR4 ;SLC/CJS - LAB ROUTINE DATA VERIFICATION ; 2/21/89 21:06 ;
LRVR5 ;SLC/CJS - LAB ROUTINE DATA VERIFICATION ;4/20/89 18:02 ;
LRVRKIL ;DALISC/FHS - LAB ROUTINE DATA VERIFICATION VARIABLE KILLER ;03/24/92
17:30
LRVRW ;SLC/CJS - LAB ROUTINE DATA VERIFICATION BY WORKLIST; 6/2/86 9:18 AM ;
LRWD ;SLC/RWF - DISPLAY NAMES OF PATIENTS WITH RECENTLY VERIFIED DATA
;2/7/91 12:06 ;
LRWLHEAD ;SLC/DCM - WORKLIST HEADINGS ;2/8/91 07:34 ;
LRWLST ;SLC/CJS,RWF- ACCESSION SETUP. LROE1,LRSTIK & LRFAS CALL HERE
;2/28/91 08:37 ;
LRWLST1 ;SLC/CJS/RWF - ACCESSION SETUP ;2/7/91 12:21 ;
LRWLST11 ;SLC/CJS,RWF - ACCESSION SETUP ;2/7/91 13:34 ;
LRWLST12 ;SLC/CJS/RWF/FHS - ACCESSION SETUP ; 9/9/87 15:41 ;
LRWLST13 ;SLC/CJS/RWF - ACCESSION SETUP ; 1/7/87 12:12 PM ;
LRWLST2 ;SLC/CJS/RWF - ACCESSION SETUP ;2/7/91 13:37 ;
LRWRKIN1 ;SLC/DCM/CJS - LRWRKINC, CONT. ; 2/22/87 11:39 AM ;
LRWRKINC ;SLC/DCM/CJS - INCOMPLETE STATUS REPORT ;2/19/91 11:47 ;
LRWRKLS1 ;SLC/CJS/DALISC/DRH - LRWRKLS, CONT. ;2/7/91 14:29 ;
LRWRKLS ;SLC/CJS/DALISC/DRH - LONG ACCESSION LIST ;2/19/91 11:46 ;
LRWRKS ;SLC/RWF - WORK SHEET ACCESSION LIST ;2/19/91 11:48 ;
LRWRKS2 ;SLC/RWF/MILW/JMC - WORK SHEET ACCESSION LIST PART 2;2/7/91 14:48 ;
LRWU ;SLC/RWF/MILW/J - UTILITY FUNCTIONS ; 12/28/88 11:04 ;
LRWU1 ;SLC/RWF/DALISC/FHS - ORDERING/ACCESSION UTILITIES ;6/5/89 16:25 ;
LRWU2 ;SLC/RWF - UTILITY # 2 ; 8/5/87 11:12 ;
LRWU3 ;SLC/RWF - COLLECT STARTING AND ENDING DATES FOR REPORTS ; 7/23/87
14:17 ;
LRWU4 ;SLC/RWF - READ ACCESSION ;2/7/91 14:49 ;
LRWU5 ;SLC/RWF/BA - ADD A NEW DATA NAME TO FILE 63 ; 5/15/87 22:53 ;
LRWU6 ;SLC/RWF/BA - MODIFY AN EXISTING DATA NAME ; 5/19/87 23:54 ;
LRWU7 ;SLC/BA - ADD A NEW ANTIBIOTIC TO FILE 63 ; 5/15/87 23:31 ;
LRX ;SLC/BA - UTILITY ROUTINES -- PREVIOUSLY ^LAB("X","...");2/8/91 07:30 ;

LR pre- and post- init routines

LRIPOS ;SLC/FHS - POST INIT V 5.2 [06/09/94 7:08 PM]
LRIPOS2 ;AVAMC/REG - SET DD(65.091,.03 PART OF LRINIT POST INITS V 5.2;7/23/92
12:39 [06/09/94 6:46 PM]
LRIPOS3 ;SLC/RWA/DALISC/JRR - LR POST INTI UPDATE MENU OPTIONS ;2/8/91 07:37
;
LRIPOS4 ;DALISC/FSH - LR POST INIT CONTINUED
LRIPOSXM ;DALISC/PAC - SEND MAIL MESSAGE TO LAB DEVELOPERS ;7/10/92 12:35
LRIPRE ;SLC/FHS/REG - PRE-INIT FOR VERSION 5.2 AFTER USER COMMIT;10/18/90
13:36 ;
LRIPRE1 ;SLC/AM/DALISC/FHS - WKLD (CAP) CODE LIST REPORT PRE INSTALL/INIT 5.2
;1/16/91 15:34 ; [06/09/94 6:20 PM]
LRIPRE2 ;DALISC/J0 - PURGE OBSOLETE WORKLOAD DATA
LRIPRECK ;SLC/FHS - PRE-INIT ENVIRONMENT CHECK FOR VERSION 5.2 ;10/18/90 13:36 ;

Routine Descriptions

LA routines

LA1103 ;SLC/RWF- TO CHECK THE STATUS OF THE LSI-11 INTERFACE ; 8/5/87 21:0 ;
LAABL3 ;SLC/RWF- ABL3/ABL4 BLOOD GAS INSTRUMENT ;7/20/90 07:08 ;
LAABL500;SLC/RAF - RADIOMETER ABL500,505,520 ;5/27/93 07:00;
LAACA ;SLC/RWF,CJS- 'ACA3' ROUTINE FOR AUTOMATED DATA ;8/16/90 14:52 ;
LAACA4 ;SLC/RWF- ACA4, ACA5, DIMENSION ;7/20/90 07:11 ;
LAALTA ;SLC/RWF- ALTAIRE ;7/20/90 07:12 ;
LAAIMX ;INDY/PLS;SLC/RAF- IMX ROUTINE FOR MEIA QUAN. DATA; 06/18/93 11:01
;;PLS 55693,31670
LAASTRA;SLC/RWF- ASTRA 4,6,8,8E,IDEAL (CALCULATING IE ANION GAP;7/20/90 07:13;
LAB ;SLC/RWF- AUTOMATED INSTRUMENT LAB INTERFACE ;9/10/90 13:59 ;
LABALARM;SLC/RWF- ALARM FOR LAB ;7/20/90 07:18 ;
LABCX4B;SLC/DLG- BECKMAN CX4 AND CX5 UNI AND BIDIRECTIONAL ;7/20/90 07:25 ;
LABCX4D;SLC/DLG - BECKMAN CX4 AND CX5 BUILD DOWNLOAD FILE. ;8/16/90 10:33 ;
LABCX4H;SLC/DLG - BECKMAN CX4 AND CX5 PROTOCOL CONTROLLER ; 3/28/89 9:37 AM ;
LABCX4I;SLC/DLG/FHS - BECKMAN BIDIRECTIONAL DIRECT CONNECT SETUP ;9/21/90
LABCX4XX;SLC/DLG- BECKMAN BIDIRECTIONAL DIRECT CONNECT INTERFACE ;8/16/90
14:53;
LABERR ; SLC/FHS - ERROR TRAP FOR LABORATORY AUTO INSTRUMENTS ;11/20/90
09:45
LABERRP; SLC/FHS - PRINT OUT LA("ERR" ERROR TRAP
LABINIT;SLC/RWF- LAB INIT RUNTIME ;8/16/90 10:18 ;
LABIOH ;SLC/RWF- ROUTINE FOR BIOVATION HEME KEYPADS ;7/20/90 07:32 ;
LABIOU ;SLC/RWF- ROUTINE FOR BIOVATION URINALYSIS KEYPAD ;7/20/90 07:33 ;
LABITKU;SLC/DLG- BECKMAN INTERLINK UPLOAD UNIDIRECTIONAL ; 5/9/89 2:36 PM ;
LABL330;SLC/ECB&RWF,DLG- ABL330 BLOOD GAS ANALYZER; ;9/17/90 12:47
LABMD87P;SLC/RWF- BMD 8700 ROUTINE USING REPORT FORMAT ;7/20/90 07:35 ;
LABTEST;SLC/RWF- AUTOMATED INSTRUMENT INTERFACE TESTING ;7/20/90 07:37 ;
LAC178 ;SLC/RWF - CORNING 178 BLOOD GAS ;7/20/90 07:41 ;
LAC178HP;SLC/FHS DUAL CORNING 178 VIA HP COMPUTER ;8/16/90 14:12
LACBIO ;SLC/DCM/RWF- COBAS BIO DATA ;7/20/90 07:43 ;
LACCHEM6;SLC/RWF- CENTRIFICHEM 600 ;7/20/90 07:43 ;
LACEL8E;SLC/DLG - COLLECT 8E ;8/16/90 14:07 ;
LACFARA;SLC/RWF- COBAS FARA ;7/20/90 07:45 ;
LACHEM1;SLC/DLG- TECHNICON CHEM1 UNIDIRECTIONAL AUTOMATED DATA;7/20/90 07:46 ;
LACL5500;SLC/RWF- AMES CLINI-TEK 5500 ;7/20/90 07:47 ;
LACLNTE;SLC/RWF- AMES CLINI-TEK FORM PRINTER AUTOMATED DATA ;8/16/90 14:53 ;
LACLNTEK;SLC/RWF- AMES CLINI-TEK AUTOMATED DATA ;8/16/90 14:54 ;
LACLT200;SLC/RWF- AMES CLINI-TEK 200 ;7/20/90 07:49 ;
LACLT20P;SLC/RWF/RAF- AMES CLINITEK 200 PLUS ; 7/14/93 8:20 AM ;
LACMIRA;SLC/DLG- COBAS MIRA ;10/22/91 08:59 ;
LACMIRAS;SLC/DLG- COBAS MIRA S ;7/20/90 07:50 ;
LACOAGX2;SLC/RWF- ROUTINE FOR COAGAMATE X2 ;7/20/90 07:51 ;
LACOARA4;SLC/RAF - ORGANON RA4 INTERFACE ;09/12/94 07:00
LACOLT ;SLC/RWF- COULTER SR DATA PROCESSING ;7/20/90 07:51 ;
LACOLT1;SLC/RWF- COULTER S+ DATA PROCESSING ;7/20/90 07:52 ;
LACOLT2;SLC/RWF- COULTER S PLUS II DATA PROCESSING ;7/20/90 07:53 ;
LACOLT24;SLC/RWF- COULTER S WITH A EDMAC MODEL 2400 INTERFACE ;7/20/90 07:53 ;
LACOLT3;SLC/RWF- FOR COULTER SR. PLUS II WITH QC MODULE ;7/20/90 07:54 ;
LACOLT5;SLC/RWF- COULTER S PLUS T660 IV V VI JT JT3 SR ST STKR;7/20/90 07:54 ;
LACOLT6;SLC/RWF- COULTER S PLUS VI, DT WITH DH INTERFACE ;7/20/90 07:55 ;
LACOLTSE;SLC/DLG/FHS - COULTER STACK S VER. 1E SOFTWARE DATA PROCESSING
;8/16/90 14:0 ;
LACOLTSS;SLC/DLG- COULTER STACK S DATA PROCESSING ;8/16/90 14:0 ;
LACRIT ;SLC/RWF- PRINT OUT CRITICAL VALUES AT DATA GATHER TIME;7/20/90 07:56 ;
LACTDMS;SLC/DLG- AMES CLINI-TEK 200 W/DMS ;7/20/90 07:57 ;
LADACOS;SLC/RWF- COULTER DACOS ;7/20/90 08:0 ;
LADEKT7B;SLC/RWF/DLG - EKTACHEM 700 BI-DIRECTIONAL ;7/23/90 11:04 ;

Routine Descriptions

LADIMD ;SLC/DLG- DIMENSION BUILD DOWNLOAD FILE. ;10/17/90 12:51 ;
 LADIMPI;SLC/DLG/FHS - DIMENSION DIRECT CONNECT SETUP ;8/16/90 14:15 ;
 LADIMPXX;SLC/DLG- DIMENSION DIRECT CONNECT INTERFACE ;8/16/90 14:15 ;
 LADJOB ;SLC/DLG- JOB DIRECT CONNECTED AUTOMATED LAB ROUTINES ;6/25/90 13:46
 LADKERM2;SLC/RWF/DLG - BUILD A KERMIT FILE TO SEND ;2/8/90 14:50 ;
 LADKERM3;SLC/RWF/DLG - UNPACK KERMIT RECORDS ;12/6/89 09:24 ;
 LADKERMI;SLC/RWF/DLG - KERMIT PROTOCOL CONTROLLER - DIRECT CONNECT ;7/19/90
 15:06 ;
 LADMND ;SLC/RWF- DEMAND ANALYZER IN MODE 3 ;7/20/90 08:06 ;
 LADOWN ;SLC/RWF - TOP LEVEL OF DOWNLOAD OPTIONS ;7/20/90 08:06 ;
 LADOWN1;SLC/DG - UTILITY PARTS OF DOWNLOAD ;7/20/90 08:07 ;
 LAE4A ;SLC/RWF- BECKMAN E4A ELECTROLYTE ANALYZER ;8/16/90 14:15 ;
 LAEKT4 ;SLC/RWF- KODAK EKTACHEM 400 ROUTINE ;7/20/90 08:11 ;
 LAEKT7 ;SLC/RWF- KODAK EKTACHEM 700 ROUTINE ;7/20/90 08:11 ;
 LAEKT7B;SLC/RWF/DLG- EKTACHEM 700 BI-DIRECTIONAL ;8/17/90 09:10 ;
 LAEKT7D;SLC/RWF/DLG - KODAK EKTACHEM 700 BUILD DOWNLOAD FILE. ;8/15/90 15:10 ;
 LAEKT7P;SLC/RWF- KODAK EKTACHEM 700 ROUTINE ** MODIFIED TO USE 2ND PRINTER
 PORT ** ;7/20/90 08:14 ;
 LAELT ;SLC/RWF- ELT 8/8DS AUTOMATED DATA ;8/16/90 13:59 ;
 LAELT8D;SLC/RWF- ORTHO ELT8 WITH 3 CELL DIFF / ELT 1500 ;7/20/90 08:16 ;
 LAEPXD ;SLC/DLG -ABBOTT EPX BUILD DOWNLOAD FILE. ;7/20/90 08:20 ;
 LAEPXPXX;SLC/DLG- AUTOMATED SINGLE INSTRUMENT EPX DIRECT CONNECT LAB INTERFACE
 ;9/5/90 14:34 ;
 LAERA ;SLC/DLG- PHOTON ERA ;7/20/90 08:21 ;
 LAEXEC ;SLC/RWF- ABBOTT EXECUTIVE ;7/20/90 08:22 ;
 LAFARA2 ;SLC/RAF- COBAS FARA II;8/1/94 06:45 ;
 LAFUNC ;SLC/DLG - GENERIC FUNCTIONS USED BY LA ROUTINES ;7/20/90 08:28 ;
 LAGEN ;SLC/CJS- LAB AUTOMATED DATA ;7/20/90 08:28 ;
 LAH1 ;SLC/RWF- TECHNICON H1 ;7/20/90 08:35 ;
 LAH480 ;SLC/RWF- HEMATRAK 360, 480, 590 ;7/20/90 08:35 ;
 LAH6K ;SLC/RWF- DUPONT H6000 AUTOMATED DATA ;7/20/90 08:36 ;
 LAH705 ;SLC/RWF- HITACHI 704/705 ;7/20/90 08:37 ;
 LAH717D;SLC/DLG - HITACHI 717 BUILD DOWNLOAD FILE. ;7/20/90 08:38 ;
 LAH717H;SLC/DLG - HITACHI 717 WITH JT-717 PROTOCOL CONTROLLER ;7/20/90 09:10 ;
 LAH717U;SLC/DLG- HITACHI 717 ROUTINE FOR AUTOMATED DATA ;7/20/90 09:10 ;
 LAH737 ;SLC/RWF- HITACHI 737 ;7/20/90 09:11 ;
 LAH747 ;SLC/FHS/RAF - HITACHI 747 ;8/15/92 15:41
 LAHLOG ;SLC/RWF- TECHNICON HEMALOG D ;7/20/90 09:12 ;
 LAHT1K ;SLC/DLG- HITACHI 736 WITH JT 1000 ;7/20/90 09:14 ;
 LAHT1KD;SLC/DLG - HITACHI 736 WITH JT1000 BUILD DOWNLOAD FILE.;8/16/90 10:31;
 LAHTCCA;SLC/DLG- HITACHI 717 THRU CCA SYSTEM ;7/20/90 09:16 ;
 LAHTCCAD;SLC/DLG - HITACHI 717 THRU CCA SYSTEM BUILD DOWNLOAD FILE. ;7/20/90
 09:17 ;
 LAHTCCAH;SLC/DLG - HITACHI 717 THRU CCA SYSTEM PROTOCOL CONTROLLER ;7/20/90
 09:18 ;
 LAHTRK ;SLC/RWF,CJS- HEMATRAK 590 DIFF COUNTER ;8/16/90 14:18 ;
 LAHWATCH;SLC/RAF/DALISC/TNN - WATCH DATA IN ^LAH GLOBAL ;1/13/92 12:41
 LAJOB ;SLC/DCM- JOB AUTOMATED LAB ROUTINES ;4/27/89 09:41 ;
 LAJOB1 ;SLC/DCM,RWF - STATUS OF AUTOMATED LAB ROUTINES ;7/11/89 10:29 ;
 LAKDA ;SLC/RWF- AM. MONITOR KDA ;7/20/90 09:23 ;
 LAKDIFF;SLC/RWF- KEYBOARD DIFFERENTIAL COUNTER ;8/16/90 10:38 ;
 LAKDIFF1;SLC/RWF,LL/RES- KEYBOARD DIFF PART 2 ;7/14/87 08:02 ;
 LAKDIFF2;SLC/RWF,LL/RES- RBC MORPHOLOGY ;7/14/87 08:01 ;
 LAKDIFF3;SLC/DLG- LAB ROUTINE DATA VERIFICATION BY WORKLIST OF KEYBOARD DIFFS
 ;7/28/88 10:01 AM ;
 LAKERM2;SLC/RWF/DLG - BUILD A KERMIT FILE TO SEND THRU LSI ;7/20/90 09:25 ;
 LAKERM3;SLC/RWF/DLG - UNPACK KERMIT RECORDS VIA LSI ;7/20/90 09:26 ;
 LAKERMIT;SLC/RWF/DLG - KERMIT PROTOCOL CONTROLLER THRU LSI ;7/20/90 09:24 ;

Routine Descriptions

LAKOAG40;SLC/RWF- ORTHO KOAGULAB 40-A ;7/20/90 09:23 ;
LAKUR ;SLC/RWF- KEYBOARD URINE COUNTER ;8/16/90 10:39 ;
LAKUR1 ;SLC/RWF - URINALYSIS Part 2 ; 9/19/87 18:36 ;
LAL13 ;SLC/RWF- PROCESS IL- 1303 DATA ;8/16/90 10:35 ;
LAL1306;SLC/IL- PROCESS IL- 1306 DATA ;8/16/90 10:36 ;
LAL1312;SLC/RWF- IL 1312 BLOOD GAS INSTRUMENT ;7/20/90 09:20 ;
LAL508 ;SLC/RWF,BUF/DCN - IL 508 ROUTINE ;7/20/90 09:21 ;
LAL943 ;SLC/RWF- IL 943 ;7/20/90 09:21 ;
LALBG3;SLC/RAF - IL BG3 Blood Gas Analyzer interface ;9/2/94 14:33 ;
LAMIAUT0;SLC/FHS - MICRO AUTO INSTRUMENT PROGRAM VITEK ;7/20/90 09:31 ;
LAMIAUT1;SLC/FHS - CONTINUE MICRO AUTO INSTRUMENT PROGRAM VITEK ;7/23/90
11:06 ;
LAMIAUT2;SLC/FHS - CONTINUE MICRO AUTO INSTRUMENT PROGRAM VITEK ;7/20/90
09:33 ;
LAMIAUT3;DLG/SLC - MICRO DISPLAY ANTIBIOTICS FOR VERIFY ;7/20/90 09:32 ;
LAMIAUT4;SLC/FHS - EDIT OR VERIFY MICRO AUTO INSTRUMENTS; ;7/20/90 09:33
LAMIAUT5;DAL/FHS - DELETE MICRO AUTOMATED DATA UTILITY
LAMIAUT6;SLC/FHS - DISPLAY MICRO DRUGS IN ORDER ;7/20/90 09:34
LAMIAUT7;FHS/SLC - CREATE LOAD LIST FOR VITEK ;7/20/90 09:34
LAMIAUT8;FHS/SLC - ADD OR DELETE FROM VITEK LOAD LIST ;7/20/90 09:35
LAMICRA;SLC/DLG - VITEK AUTOINSTRUMENT LOAD OF SPECIAL CHARACTERS ;7/20/90
09:36 ;
LAMILL ;SLC/DLG - BUILD LOAD LIST FOR MICROSCAN ;7/20/90 09:36 ;
LAMIV00;SLC/DLG- PROCESS VITEK V VALUE FROM FILE ;7/20/90 09:37 ;
LAMIV10;SLC/DLG - PROCESS VITEK BACILLUS AND UID CARDS ;7/20/90 09:37 ;
LAMIV11;SLC/DLG - PROCESS VITEK GPS & YBC CARDS ;7/20/90 09:38 ;
LAMIV12;SLC/DLG - PROCESS VITEK GNS CARDS ;7/20/90 09:38 ;
LAMIVT5;SLC/DLG/DAL/FHS - VITEK MICRO DATA NEW FORMAT AMS 06.1;8/16/90 13:37 ;
LAMIVT6;SLC/DLG/DAL/FHS - VITEK MICRO DATA ENCODED NEW FORMAT UNI AMS
06.1;8/16/90 13:37 ;
LAMIVTE6;SLC/DLG/FHS/DAL - VITEK MICRO DATA ENCODED AMS 06.1 NEW FORMAT ;5/26/92
LAMIVTK;SLC/DLG - VITEK MICRO DATA ;8/16/90 13:37 ;
LAMIVTK6;SLC/DLG - VITEK MICRO DATA BCI R02.1 R02.2 ;12/23/91 ;
LAMIVTKC;SLC/DLG - VITEK PROTOCOL CONTROLLER ;7/20/90 09:40 ;
LAMIVTKD;SLC/RWF - VITEK BUILD DOWNLOAD FILE. ;7/18/89 11:51 ;
LAMIVTKU;SLC/DLG - VITEK MICRO DATA ;8/16/90 13:36 ;
LAMLA1KC;SLC/DLG/FHS - ELECTRA 900/900C/1000C ;03/25/93 15:41 ;
LAMLA7 ;SLC/RWF- MLA ELECTRA 700 ;7/20/90 09:42 ;
LAMODH ;SLC/RWF- MODULUS COMP-U-DIFF ;7/20/90 09:42 ;
LAMODU ;SLC/RWF- MODULUS UR-O-COMP ;7/20/90 09:43 ;
LAMODUT;SLC/DLG- MODULUS KEYPAD VERTICAL FORMAT ;7/20/90 09:43 ;
LAMONARK;SLC/RWF- IL MONARK ;7/20/90 09:45 ;
LAMSA ;SLC/DLG - MICROSCAN AND AUTOSCAN4 DATA ANALYZER ;8/16/90 13:35 ;
LAMSAL ;SLC/DLG - MICROSCAN PROCESS MIC/THERAPY RECORD ;3/7/91 09:47 ;
LAMSBLD;SLC/DLG - BUILD MICROSCAN MIC X-REF IN FILE 62.06 ;7/20/90 09:48 ;
LAMSD ;SLC/DLG - MICROSCAN BUILD DOWNLOAD FILE ;7/20/90 09:48 ;
LAMSP ;SLC/DLG - MICROSCAN PROTOCOL ROUTINE W/O ACK-NAK ;7/20/90 09:49 ;
LAMSPAN;SLC/DLG - MICROSCAN PROTOCOL ROUTINE W/ ACK-NAK ;7/20/90 09:50 ;
LAMSTAT;SLC/RWF- MULTISTAT III ROUTINE ;7/20/90 09:50 ;
LANOVA ;SLC/RWF- NOVA 4+4 / 11+11 ;7/20/90 09:56 ;
LANOVST;SLC/DLG- NOVA STAT PROFILE ANALYSER ;7/20/90 09:56 ;
LANTEG ;ISC/XTSUMBLD KERNEL - Package checksum checker ;JAN 04, 1994@17:47:36
LANTEG0;ISC/XTSUMBLD KERNEL - Package checksum checker ;JAN 04, 1994@17:47:36
LAPARA ;SLC/RWF- PARALLEL ANALYZER ;7/20/90 09:57 ;
LAPARAP;SLC/RWF- PARALLEL - PRINTER PORT FORMAT ;7/20/90 09:57 ;
LAPER ;SLC/DLG- PERSPECTIVE ;7/20/90 09:58 ;
LAPERD ;SLC/DLG AMERICAN MONITOR PERSPECTIVE BUILD DOWNLOAD FILE. ;7/20/90
09:58 ;

Routine Descriptions

LAPFICH;AVAMC/REG- MICROFICH PATH REPORTS ;7/20/90 09:59
LAPMAX ;SLC/RWF- PARAMAX ;7/20/90 10:01 ;
LAPMAXD;SLC/DLG PARAMAX BUILD DOWNLOAD FILE. ;7/20/90 10:01 ;
LAPORTXX;SLC/DLG- AUTOMATED SINGLE INSTRUMENT LAB INTERFACE ;8/16/90 14:22 ;
LAPX ;SLC/RWF - TEMPLATE ROUTINE FOR AUTOMATED DATA, this routine will not
work until INTENTIONAL bugs are removed ;7/20/90 10:02 ;
LARA1K ;SLC/RWF- TECHNICON RA-1000 ;7/20/90 10:02 ;
LARA2K ;SLC/RWF-DCM FOR RA 2000 THRU PORT EXPANDER ;7/20/90 10:03 ;
LARAPMT;SLC/DLG- RAPIMAT URINE PAD ROUTINE ;7/20/90 10:04 ;
LARMK ;SLC/FHS - SET UP REMARKS FOR AUTO-INSTRUMENTS ;10/10/90 18:16
LAS550 ;SLC/RWF- COULTER S550,770 ;7/20/90 10:04 ;
LAS790 ;SLC/RWF- COULTER S790 ;7/20/90 10:05 ;
LASCT ;SLC/RWF- COULTER S with COURT II ;7/20/90 10:05 ;
LASET ;SLC/RWF- AUTO INSTRUMENTS SETUP VAR FOR DATA COLECTION ;2/19/91 12:03;
LASMA12;SLC/DLG,PORTLAND/JT,SLC/RWF- SMA 12/60 INTERFACE ;7/20/90 10:08 ;
LASMA2 ;SLC/RWF- SMA II/(GENERATION 2) SYSTEM ROUTINE ;7/20/90 10:08 ;
LASMA2C;SLC/RWF- SMA II/C SYSTEM ROUTINE ;7/20/90 10:09 ;
LASM4;SLC/RWF- SMAC RUN CONTROL FOR SMAC (LASMACA) ;7/20/90 10:10 ;
LASMACA;SLC/RWF- GETS DATA FROM SMAC ;8/16/90 11:03 ;
LASP120;SLC/RWF- VICKERS SP-120 INTERFACE FOR SMA 18/60 AUTOMATED DATA
;7/20/90 10:12 ;
LASPEC ;SLC/RWF- ABBOTT SPECTRUM VERSION M2.0 ;7/20/90 10:12 ;
LASTATUS;SLC/FHS - TO CHECK SYSTEM STATUS OF AUTO INSTRUMENT JOBS ;11/6/89
12:03
LASTRA ;SLC/RWF- ASTRA 4,6,8,8E,IDEAL,CX3 (NON-CALCULATING) ;8/16/90 13:53 ;
LASYS8K;SLC/DLG- SYSMEX 8000 ;7/20/90 10:13 ;
LASYSMEX;SLC/RWF- TOA SYSMEX K-1000/E-2000/E-5000 ;7/20/90 10:14 ;
LATDX ;SLC/RWF- ABBOTT TDX,PACKARD TDX ;7/20/90 10:16 ;
LATDX1 ;SLC/RWF- ABBOTT TDX WITH SPEC ID VERSION 10.1 ;10/25/90 14:31 ;
LATOA ;SLC/RWF- TOA AUTO INSTRUMENT ;7/20/90 10:17 ;
LAWATCH;SLC/RWF/FHS - WATCH DATA IN ^LA GLOBAL ;8/8/89 11:36 ;
LAYRIS ;SLC/RWF- IRIS ;7/20/90 09:22 ;

LA pre- and post- init routines

LAIPOST ;SLC/FHS - AUTO INSTRUMENTS POST INIT ;5/10/90 11:33
LAIPRE ;DALISC/JRR - AUTO INSTRUMENTS PRE INIT ENVIRONMENT CHECK ; 3/14/94

OE/RR Routines

The following routines are namespaced LR but are actually part of the OE/RR package.

OERR routines that are LAB namespaced

LRX6 ;SLC/DCM - ENTRY POINTS TO MOVE LAB FILES TO 101 ;10/3/90 13:19 ;
LRX60 ;SLC/DCM - MOVE FILE 60 TO 101 ; 7/3/89 10:30 ;
LRX62P6;SLC/DCM - MOVE FILE 62.6 ENTRIES INTO 101 ;10/2/90 17:20 ;
LRX62P61;SLC/DCM - MOVE FILE 62.6 INTO 101 CONT. ;9/7/89 17:33 ;
LRX6PRO;SLC/DCM - MOVE LAB PROFILES INTO 101 CONT. ;11/26/90 16:10 ;
LRX00 ; SLC/DCM - Process Lab actions
LRX000 ; SLC/DCM - Lab Orders ;4/18/91 10:31
LRX01 ; SLC/DCM - Lab Orders ;4/18/91 10:31
LRX010 ; SLC/DCM - Process lab order from OE/RR ;5/20/91 07:10 ;
LRX011 ; SLC/DCM - Setup order & accession for OE/RR ;3/29/90 16:40 ;
LRX01A ; SLC/DCM - Lab Orders cont.;4/18/91 10:31
LRX02 ; SLC/DCM - Lab Order Cont.
LRX03 ; SLC/DCM - Lab Order Cont.
LRX04 ; SLC/DCM - Lab Order Cont. ;3/11/91 14:02
LRX04A ; SLC/DCM - Lab Order Cont. ;3/11/91 14:02
LRX05 ; SLC/DCM - Lab collection times ;1/17/92 11:52 ;
LRX06 ; SLC/DCM - Comment Utility ; 3/31/88 3:54 PM ;
LRX07 ; SLC/DCM - Lab collection samples ; 7/3/89 15:07 ;
LRX08 ; SLC/DCM - Check max freq of lab orders ;8/30/89 10:09
LRX09 ; SLC/DCM - Order Comments
LRXOS0 ; SLC/DCM - Order timing utility ;1/29/91 14:44
LRXOS1 ; SLC/DCM - Order cancel by patient movement ;7/17/90 12:17
LRXREF ;SLC/RWA - BUILD CROSS-REFERENCES FOR RE-INDEX ;7/9/92 01:26
LRXREF1;SLC/RWA - CONTINUE BUILD X-REF FOR RE-INDEX ;5/15/90 12:41

OE/RR routines that are LAB namespaced, replaced with each new version of OE/RR.

LRO LRO ;SLC/DCM - Being replaced ;1/10/91 16:0 ;
LRO1 LRO1 ;SLC/DCM - Being replaced ; 3/9/89 19:39 ;
LRO2 LRO2 ;SLC/DCM - Being replaced ;1/10/91 16:01 ;
LRO3 LRO3 ;SLC/DCM - Being replaced ; 7/3/89 15:07 ;
LRO4 LRO4 ;SLC/DCM - Being replaced ;1/31/91 08:46 ;
LRO5 LRO5 ;SLC/DCM - Being replaced ;1/10/91 16:01 ;
LRO6 LRO6 ;SLC/DCM - Being replaced ; 2/14/89 18:07 ;
LRO7 LRO7 ;SLC/DCM - Being replaced ;1/9/91 17:32 ;
LRO8 LRO8 ;SLC/DCM - Being replaced ;1/10/91 16:0 ;
LRORDST1;SLC/CJS,RWF - Being replaced ;3/29/90 16:40 ;
LROX0 ;SLC/DCM - Being replaced ;1/29/91 14:44
LROX1 ;SLC/DCM - Being replaced ;7/17/90 12:17

CALLABLE ROUTINES

Callable Routines

The following listings are drawn from the Forum DBA menu.

Supported References

This list is of the references approved by the DBA.

LISTING OF SUPPORTED REFERENCES BY PACKAGE JUL 28,1994 15:17 PAGE 1
NAME

DBIA # TYPE

CUSTODIAL PACKAGE: LAB SERVICE

LAB(61.4,	10133	File
LAB(61.4,D0,0)		
LAB(61.2,	10131	File
LAB(61.2,D0,0)		
LAB(61.3,	10132	File
LAB(61.3,D0,0)		
LAB(60,	10054	File
LAB(60,D0,0)		
LAB(61.1,	10130	File
LAB(61.1,D0,0)		
LAB(61.6,	10135	File
LAB(61.6,D0,0)		
LAB(61.5,	10134	File
LAB(61.5,D0,0)		
LAB(61,	10055	File
LAB(61,D0,0)		

Entry Point References

This list is of the agreements between packages. Any restrictions on the use of the entry points are detailed in this report.

**LAB SERVICE Custodial DBI Agreements **

```

-----
                NAME: DBIA240-B                ENTRY: 710
CUSTODIAL PACKAGE: LAB SERVICE                Dallas
SUBSCRIBING PACKAGE: AUTOMATED MED INFO      Albany
                USAGE: Private                APPROVED: APPROVED
                STATUS: Active                EXPIRES:
DURATION: Till Otherwise Agr  VERSION:
                FILE:                        ROOT:
DESCRIPTION:                                TYPE: Routine
Laboratory Package has given permission to AMIE to make the following
calls: Routine Calls:
    CH^LRRP2
    MI^LRRP2
    PT^LRX   Current Agreement number 95 Per our phone conversation on
6/7/93. No more setting of the ZTSK AND ZTQUEUED variables. Call the
following entry points: D DT^LRX,EN^LRPARAM. This will work for any
version of Lab.

ROUTINE: LRRP2
COMPONENT: CH
VARIABLES:
COMPONENT: MI
VARIABLES:

```

```

                NAME: DBIA240-C                ENTRY: 715
CUSTODIAL PACKAGE: LAB SERVICE                Dallas
SUBSCRIBING PACKAGE: AUTOMATED MED INFO      Albany
                USAGE: Private                APPROVED: APPROVED
                STATUS: Active                EXPIRES:
DURATION: Till Otherwise Agr  VERSION:
                FILE:                        ROOT:
DESCRIPTION:                                TYPE: Routine
Laboratory Package has given permission to AMIE to make the following
calls: Routine Calls:
    PT^LRX   Current Agreement number 95 Per our phone conversation on
6/7/93. No more setting of the ZTSK AND ZTQUEUED variables. `
}"/\\ Call the following entry points: D DT^LRX,EN^LRPARAM. This will work for
any version of Lab.

ROUTINE: LRX
COMPONENT: PT
VARIABLES:
COMPONENT: DT
VARIABLES:

```

```

                NAME: DBIA240-D                ENTRY: 716
CUSTODIAL PACKAGE: LAB SERVICE                Dallas

```

SUBSCRIBING PACKAGE: AUTOMATED MED INFO Albany
 USAGE: Private APPROVED: APPROVED
 STATUS: Active EXPIRES:
 DURATION: Till Otherwise Agr VERSION:
 FILE: ROOT:
 DESCRIPTION: TYPE: Routine

Laboratory Package has given permission to AMIE to make the following calls:
 Per our phone conversation on 6/7/93. No more setting of the ZTSK AND ZTQUEUED
 variables. Call the following entry points: D
 DT^LRX,EN^LRPARAM. This will work for any version of Lab.

ROUTINE: LRPARAM
 COMPONENT: EN
 VARIABLES:

NAME: DBIA95-B ENTRY: 558
 CUSTODIAL PACKAGE: LAB SERVICE Salt Lake City
 SUBSCRIBING PACKAGE: COMPENSATON AND PE Albany
 USAGE: Private APPROVED: APPROVED
 STATUS: Active EXPIRES:
 DURATION: Till Otherwise Agr VERSION:
 FILE: ROOT:
 DESCRIPTION: TYPE: Routine

Request an agreement with the lab developers for usage of the following:

variables:

Only those associated with the routines below

Routines from indicated entry points:

PT^LRX

ROUTINE: LRX
 COMPONENT: PT
 VARIABLES:

NAME: DBIA95-C ENTRY: 559
 CUSTODIAL PACKAGE: LAB SERVICE Salt Lake City
 SUBSCRIBING PACKAGE: COMPENSATON AND PE Albany
 USAGE: Private APPROVED: APPROVED
 STATUS: Active EXPIRES:
 DURATION: Till Otherwise Agr VERSION:
 FILE: ROOT:
 DESCRIPTION: TYPE: Routine

Request an agreement with the lab developers for usage of the following:

variables:

Only those associated with the routines below

Routines from indicated entry points:

SWITCH^LRRP2

Callable Routines

ROUTINE: LRRP2
COMPONENT: SWITCH
VARIABLES:

NAME: DBIA59-B ENTRY: 520
CUSTODIAL PACKAGE: LAB SERVICE Salt Lake City
SUBSCRIBING PACKAGE: INTERIM MANAGEMENT Birmingham
USAGE: Private APPROVED: APPROVED
STATUS: Active EXPIRES:
DURATION: Till Otherwise Agr VERSION:
FILE: ROOT:
DESCRIPTION: TYPE: Routine
- ECT namespaced option runs routine ^LRUPACA
Enter ACTION: S DIC=68,DIC(0)="QEAM" D ^DIC K DIC I Y>0 S LRAA=+Y,
LRAA(1)=\$P(Y,U,2)

SEE DBIA59-A

ROUTINE: LRUPACA

NAME: DBIA59-C ENTRY: 521
CUSTODIAL PACKAGE: LAB SERVICE Salt Lake City
SUBSCRIBING PACKAGE: INTERIM MANAGEMENT Birmingham
USAGE: Private APPROVED: APPROVED
STATUS: Active EXPIRES:
DURATION: Till Otherwise Agr VERSION:
FILE: ROOT:
DESCRIPTION: TYPE: Routine
- ECT namespaced option runs routine ^LRCAPS.

- Refences file 68 Accession (read only)
2 DATE
.01 DATE
1 ACCESSION NUMBER
.01 LRDFN
11 TESTS
.01 TESTS

SEE DBIA59-A

ROUTINE: LRCAPS

NAME: DBIA207 ENTRY: 207
CUSTODIAL PACKAGE: LAB SERVICE Dallas
SUBSCRIBING PACKAGE: SURGERY Birmingham
USAGE: Private APPROVED: APPROVED
STATUS: Active EXPIRES:
DURATION: Till Otherwise Agr VERSION:
FILE: ROOT:
DESCRIPTION: TYPE: Routine
Surgery is granted a database integration agreement with Laboratory allowing
Surgery to make a call to LRRP2 by executing %ZOSF("TEST"), then calling LRRP2.

ROUTINE: LRRP2

FILE LIST AND DESCRIPTIONS

File List and Descriptions

File List and Descriptions

File List

The files listed below are Laboratory files that will be exported with Laboratory Version 5.2 software package:

FILE	UPDATE THE DATA DICTIONARY	DATA COMES WITH FILE	MERGE OR OVERWRITE SITE'S DATA
60	LABORATORY TEST	YES	MERGE
61	TOPOGRAPHY FIELD	YES	
61.1	MORPHOLOGY FIELD	YES	
61.2	ETIOLOGY FIELD	YES	
61.3	FUNCTION FIELD	YES	
61.4	DISEASE FIELD	YES	
61.5	PROCEDURE FIELD	YES	
61.6	OCCUPATION FIELD	YES	
62	COLLECTION SAMPLE	YES	
62.05	URGENCY	YES	
62.06	ANTIMICROBIAL SUSCEPTIBILITY	YES	
62.07	EXECUTE CODE	YES	
62.1	DELTA CHECKS	YES	
62.2	LAB SECTION	YES	
62.3	LAB CONTROL NAME	YES	
62.4	AUTO INSTRUMENT	YES	
62.5	LAB DESCRIPTIONS	YES	
62.55	AGGLUTINATION STRENGTH	YES	
62.6	ACCESSION TEST GROUP	YES	
63	LAB DATA	YES	
63.9999	ARCHIVED LR DATA	YES	
64	WKLD CODE	YES	OVERWRITE
64.03	WKLD LOG FILE	YES	
64.05	NON WORKLOAD PROCEDURES	YES	OVERWRITE
64.1	WKLD DATA	YES	
64.19999	ARCHIVED WKLD DATA	YES	
64.2	WKLD SUFFIX CODES	YES	OVERWRITE
64.21	WKLD CODE LAB SECT	YES	OVERWRITE
64.22	WKLD ITEM FOR COUNT	YES	OVERWRITE
64.3	WKLD INSTRUMENT MANUFACTURER	YES	OVERWRITE
64.5	LAB REPORTS	YES	
64.6	INTERIM REPORTS	YES	
64.7	CUMULATIVE	YES	
65	BLOOD INVENTORY	YES	
65.4	BLOOD BANK UTILITY	YES	
65.5	BLOOD DONOR	YES	
65.9	LAB LETTER	YES	
65.9999	ARCHIVED BLOOD INVENTORY	NO	

File List and Descriptions

66	BLOOD PRODUCT	YES	NO	
66.2	BLOOD BANK VALIDATION	YES	NO	OVERWRITE
66.5	OPERATION (MSBOS)	YES	NO	
66.9	BLOOD COMPONENT	YES	NO	
67	REFERRAL PATIENT	YES	NO	
67.1	RESEARCH	YES	NO	
67.2	STERILIZER	YES	NO	
67.3	ENVIRONMENTAL	YES	NO	
67.4	NON PATIENT WORKLOAD	YES	NO	
67.9	LAB MONTHLY WORKLOADS	YES	NO	
67.99999	ARCHIVED LAB MONTHLY WORKLOADS	YES	NO	
68	ACCESSION	YES	NO	
68.2	LOAD/WORK LIST	YES	NO	
68.4	WORKLIST HEADINGS	YES	NO	
68.45	GROUP USER MANUAL	YES	NO	
69	LAB ORDER ENTRY	YES	NO	
69.1	COLLECTION LIST	YES	NO	
69.2	LAB SECTION PRINT	YES	NO	
69.9	LABORATORY SITE	YES	NO	
69.91	LR ROUTINE INTEGRITY CHECKER	YES	YES	OVERWRITE
95	LAB JOURNAL	YES	NO	

Brief File Descriptions

The following is a brief description of the Laboratory files. For a complete description of the files and fields refer to the file section of the Laboratory Planning and Implementation Guide V. 5.2. For a printout of the files and fields use the List File Attributes [DILIST] option of VA FileManager.

60 LABORATORY TEST

This is the file that holds the information about individual Laboratory test.

61 TOPOGRAPHY FIELD

This is the TOPOGRAPHY FIELD file of SNOMED.

61.1 MORPHOLOGY FIELD

This is the MORPHOLOGY FIELD file of SNOMED.

61.2 ETIOLOGY FIELD

This is the ETIOLOGY FIELD file of SNOMED.

61.3 FUNCTION FIELD

This is the FUNCTION FIELD file of SNOMED.

61.4 DISEASE FIELD

This is the DISEASE FIELD file of SNOMED.

61.5 PROCEDURE FIELD

This is the PROCEDURE FIELD file of SNOMED.

61.6 OCCUPATION FIELD

This is the OCCUPATION FIELD file of SNOMED.

62 COLLECTION SAMPLE

Collection samples for laboratory specimens.

62.05 URGENCY

This file contains the defined urgencies.

62.06 ANTIMICROBIAL SUSCEPTIBILITY

This file is used by each laboratory to define specific information about the types of antibacterial antibiotics your laboratory uses.

62.07 EXECUTE CODE

The execute code file is used to store a variety of program instructions that are used in various programs in the Laboratory package.

62.1 DELTA CHECKS

The DELTA CHECKS file contains entries whose use is optional. They are entered in the LABORATORY TEST file (#60) under the site/specimen for the Type of delta check field.

62.2 LAB SECTION

This file defines the functional laboratory areas. Each area may have multiple accession areas. Entries may be added, but supplied entries should not be modified or deleted.

62.3 LAB CONTROL NAME

This file contains the definition of each of the laboratory controls used as part of the laboratory's quality control program.

62.4 AUTO INSTRUMENT

This is the master file controlling how the Laboratory package interprets the running of the instruments interfaced to the CORE system.

62.5 LAB DESCRIPTIONS

This file is basically a dictionary of abbreviated codes or notations which are used in the laboratory repeatedly. Each one of the canned codes will expand to a full length message whenever the code is typed in at a "Select COMMENT:" prompt.

62.55 AGGLUTINATION STRENGTH

List of all strengths of reactions.

62.6 ACCESSION TEST GROUP

This file is used to setup Accession Test Groups (menus for accessioning tests).

63 LAB DATA

Patient's verified laboratory data.

63.9999 ARCHIVED LR DATA

This file is where patient lab data are stored during the archive process. It has the same data definitions as the Subfile #63.04 in LAB DATA file (#63). This file requires no editing by the user.

64 WKLD CODE

This file contains the list of WKLD Codes, which are used to compile Laboratory workload statistics. This file is exported with data from the most current instrument listings.

64.03 WKLD LOG

This file contains an entry for each WKLD related activity.

64.05 WKLD NON WORKLOAD PROCEDURES

Non workload activities Procedure List not to be added to weighted workload.

64.1 WORKLOAD WKLD DATA

This file contains the Laboratory workload data.

64.19999 ARCHIVED WORKLOAD WKLD DATA

This file contains Laboratory archived workload data.

64.2 WKLD SUFFIX CODES

This file contains a listing of National approved Workload Suffix codes.

64.21 WKLD CODE LAB SECT

This file contains the lab section to be used. This field is not the lab section which is used at the local site.

64.22 WKLD ITEM FOR COUNT

This file contains all of the approved item description used for counting Workload data.

64.3 WKLD INSTRUMENT MANUFACTURER

This file contains an approved list of Venders/Manufacturers of Laboratory equipment of test reagents.

64.5 LAB REPORTS

This file contains the design for the output format for the cumulative report and the supervisor's reports.

64.6 INTERIM REPORTS

This file is used to define whether or not your site will be generating interim reports of patient lab values and to what locations these reports will be sent or routed.

64.7 CUMULATIVE

This file stores temporary pages of the cumulative report. The data in this file is maintained by the cumulative routines.

65 BLOOD INVENTORY

Units of various blood components.

65.4 BLOOD BANK UTILITY

This file contains donor affiliation groups, collection sites, items related to donor history, and transfusion reaction types.

65.5 BLOOD DONOR

List of blood donors with demographic, collection, and test data and components prepared from each collection.

65.9 LAB LETTER

This file stores lab consultations and blood donor letters.

65.9999 ARCHIVED BLOOD INVENTORY

This is the Archived file for the various blood components.

66 BLOOD PRODUCT

Blood products and reagents for blood banks and transfusion services.

66.2 BLOOD BANK VALIDATION

This file provides a mechanism for documenting the mandated validation of the Blood Bank software documentation.

66.5 OPERATION (MSBOS)

Contains operations/procedures with identified maximum Surgical Blood Order Schedules (MSBOS).

66.9 BLOOD COMPONENT

This file is used as a pick list of blood components available to be ordered by users needing to make a selection from another DHCP package. This file is locally edited by the LIM.

67 REFERRAL PATIENT

This file defines the patients demographic information for referral patients for whom test values will be entered into the system.

67.1 RESEARCH

This file contains the names of research entities (i.e., animals and tissues, etc.)

67.2 STERILIZER

This file is used for names of sterilizers in the hospital.

67.3 ENVIRONMENTAL

This file is used by laboratory to enter names for environmental cultures or cultures of other inanimate entities.

67.4 NON PATIENT WORKLOAD

This file will be developed in later version to support non workload functions (i.e., TQI, QC).

67.9 LAB MONTHLY WORKLOADS

This file is used to collect workload data in preparation for transmission to the National Data Base Center.

67.99999 ARCHIVED LAB MONTHLY WORKLOADS

This field contains archived LAB MONTHLY WORKLOADS file data.

68 ACCESSION

This file contains entries which represent the functional subdivisions or departments of the laboratory, referred to by the Laboratory package software as accession areas.

68.2 LOAD/WORK LIST

This file contains the information needed to define each load or work list used to organize the workload in the laboratory.

68.4 WORKLIST HEADINGS

This file allows the lab to customize the short accession list.

68.45 GROUP USER MANUAL

This file is for future use.

69 LAB ORDER ENTRY

This file controls the orderly sequence of lab test ordering.

69.1 COLLECTION LIST

This contains the lab collection list entries.

69.2 LAB SECTION PRINT

This file used to hold print headers for anatomic path reports and as a temporary holding file for pathology cumulative, incomplete and complete reports. It is also used for Blood Bank Module special report format.

69.9 LABORATORY SITE

This file holds specific information which defines certain site parameters relating to the actual functioning of your laboratory.

69.91 LR ROUTINE INTEGRITY CHECKER

This file contains routine size (^%ZOSF("size")) and routine bit size (^LRINTEG) for exported lab packages by version number.

95 LAB JOURNAL

This file contains medical journals which provides references for various Bacteriology articles.

EXPORTED OPTIONS

Exported Options

This section provides a list of exported options in the Laboratory package. It also include the distribution of menus to users and note any restrictions on menu distribution.

Laboratory Options List

OPTION LIST MENU TEXT	AUG 21,1994 14:48 NAME	PAGE 1
Check the lab interface	LA 1103	
AP Microfiche Archive	LA AP FICHE	
Set instrument to run by Accession	LA AUTO ACC	
Set instrument to run by load list	LA AUTO LLIST	
Direct Connect Auto-Instrument Start	LA DIR JOB	
Download a load list to an Instrument.	LA DOWN	
Lab Error Trap Listing	LA ERR PRINT	
Lab interface menu	LA INTERFACE	
Restart processing of instrument data	LA JOB	
Keypad differential for CRT's	LA KB DIFF	
Test the interface	LA LAB TEST	
Change instrument run mode.	LA LRL/AC SWITCH	
Automated Microbiology Menu	LA MI MENU	
MicroScan Load Worklist (Build)	LA MI MICROSCAN L/W BUILD	
Load Vitek Special Characters	LA MI SPECIAL CHARACTER LOAD	
Verify Micro Auto Data	LA MI VERIFY AUTO	
Vitek Load Worklist (Build)	LA MI VITEK L/W BUILD	
Watch the data in the LA global.	LA WATCH LAB	
Edit controls added to the accessions each day	LR ACC CONTROLS	
Accession order then immediately enter data	LR ACC THEN DATA	
Clear data from the LAR global	LR ARCHIVE CLEAR	
Find patient's archived data	LR ARCHIVE DATA	
Archive lab data	LR ARCHIVE MENU	
Convert archived data to use New Person file	LR ARCHIVE NP CONVERSION	
Purge data found in the Search option	LR ARCHIVE PURGE	
Read data from off-line media	LR ARCHIVE READ MEDIA	
Restore archived data to LR global	LR ARCHIVE RESTORE	
Search for lab data to archive	LR ARCHIVE SEARCH	
Write data to off-line media	LR ARCHIVE WRITE MEDIA	
Download Format for Intermec Printer	LR BARCODE FORMAT LOAD	
Lab test turnaround time	LR CAPTT	
Count accessioned tests	LR COUNT ACC TESTS	
Process data in lab menu	LR DO!	
Phlebotomy menu	LR GET	
Health Department report	LR HEALTH DEPT	
Accessioning menu	LR IN	
Infection warning edit	LR INF WARN	
LAB ROUTINE INTEGRITY MENU	LR INTEGRITY	
Load Integrity File	LR INTEGRITY LOAD	
Loop thru LR INTEGRITY	LR INTEGRITY LOOP	
Check a single routine size	LR INTEGRITY SINGLE	
LIM workload menu	LR LIM/WKLD MENU	
Lookup accession	LR LOOKUP ACCESSION	
Results menu	LR OUT	

Exported Options

Misc. Processing Menu	LR PROCESS, MISC
Rollover Accession (Manual)	LR ROLLOVER
Summary list (supervisors')	LR SUP SUMMARY
Supervisor workload menu	LR SUPER/WKLD MENU
Lab statistics menu	LR WKLD
Review accession workload	LR WKLD AUDIT
WKLD code list by code	LR WKLD CODE BY CODE
WKLD code list by name	LR WKLD CODE BY NAME
Edit workload comments	LR WKLD COMMENTS
PHASE 1: Move data from 64.1 to 67.9.	LR WKLD LMIP 1
Recompile Phase 1 LMIP Data.	LR WKLD LMIP 1 REPEAT
PHASE 2: Collect data for transmit to NDB.	LR WKLD LMIP 2
PHASE 3: Print of data to be sent to NDB.	LR WKLD LMIP 3
PHASE 4: Create E-mail message for NDB.	LR WKLD LMIP 4
PHASE 5: Purge monthly WKLD data from 67.9.	LR WKLD LMIP 5
Manually compile WKLD and workload counts	LR WKLD MANUAL
Workload manual input	LR WKLD MANUAL INPUT
Requesting center dictionary	LR WKLD REQUEST
Lab section list by code	LR WKLD SECTION BY CODE
Lab section list by name	LR WKLD SECTION BY NAME
Service dictionary	LR WKLD SERVICE
Turn on site workload statistics	LR WKLD STATS ON
Turn on workload stats for accession area	LR WKLD STATS ON ACC AREA
Std/QC/Reps Manual Workload count	LR WKLD STD/QC/REPS
Lab subsection by Lab section	LR WKLD SUB BY SECTION
Lab subsection list	LR WKLD SUBSECTION
Test dictionary	LR WKLD TEST DICT
WKLD statistics reports	LR WKLD2
File listings	LR WKLD3
LMIP Reports/Data Collection	LR WKLD4
Cumulative menu	LRAC
Reprint a permanent page from cumulative	LRAC 1 PAGE
Mumps A index of the LAB REPORTS file	LRAC A
Mumps A, AC, & AR indexes of the LAB REPORTS	LRAC A AC AR
Mumps AC index of the LAB REPORTS file	LRAC AC
Mumps AR index of the LAB REPORTS file	LRAC AR
Diagnostic routine for Lab Reports file (64.5)	LRAC DIAG
Patient Lab Discharge Summary (Manual)	LRAC DISCHARGE
Force cumulative data to Permanent Page	LRAC FORCE
Print a full patient summary	LRAC FULL PATIENT SUMMARY
Initialize LAC global & X references	LRAC INITIALIZE
List of patients by location for cumulative report	LRAC LIST
Reprint cumulative on a given location	LRAC LOC
Reprint cumulative from location to location	LRAC LOC-LOC
Manual queuing of cumulative	LRAC MANUAL
Manual Queuing of Fileroom Cum	LRAC MANUAL FILEROON CUM Reprint
cumulative on a given patient	LRAC PT
Purge the Cumulative file	LRAC PURGE
Cumulative device status	LRAC STATUS
Re-cross-reference indexes in LAB REPORTS file	LRAC XREF
Long form accession list	LRACC1
Short accession list	LRACC2
Work sheet Accession list	LRACC3
Work sheet of all unverified accessions for a date	LRACC4
Supervisor's report	LRACS MANUAL
Add tests to a given accession.	LRADD TO ACC

Add tests to an already existing order number	LRADD TO ORDER
Lab add test(s) to an existing order	LRADDTST
Anatomic pathology	LRAP
Add patient(s) to report print queue	LRAP ADD
Delete report print queue	LRAP DELETE
Print all reports on queue	LRAP PRINT ALL ON QUEUE
Print single report only	LRAP PRINT SINGLE
Sum of accessions by date, anat path	LRAPA
AFIP registries	LRAPAFIP
Alphabetical autopsy list	LRAPAUA
Data entry for autopsies	LRAPAUDA
Autopsy protocol & ICD9CM coding	LRAPAUDAA
Autopsy protocol & SNOMED coding	LRAPAUDAB
Autopsy protocol	LRAPAUDAP
Special studies, autopsy	LRAPAUDAS
Final autopsy diagnoses date	LRAPAUFD
Path cases by resident, tech, senior or clinician	LRAPAUFL
Accession counts by senior pathologist	LRAPAUFC
Autopsy administrative reports	LRAPAUFP
Provisional anatomic diagnoses	LRAPAUFPAD
Autopsy protocol/supplementary report	LRAPAUPT
Autopsy data review	LRAPAUURV
Autopsy supplementary report	LRAPAUUSR
Autopsy status list	LRAPAUSTATUS
Print log book	LRAPBK
Anatomic pathology topography counts	LRAPC
Coding, anat path	LRAPCODE
Display cytopath reports for a patient	LRAPCYCUM
% Pos, Atyp, Dysp, Neg, Susp, Unsat cytopath	LRAPCYPCT
Print cytopathology report for a patient	LRAPCYSGL
Data entry, anat path	LRAPD
Delete anat path descriptions by date	LRAPDAR
Enter/edit lab description file	LRAPDES
Delete free text specimen entries	LRAPDFS
Clinical Hx/Gross Description/FS	LRAPDGD
FS/Gross/Micro/Dx/ICD9CM Coding	LRAPDGI
FS/Gross/Micro/Dx	LRAPDGM
FS/Gross/Micro/Dx/SNOMED Coding	LRAPDGS
Disease (SNOMED) enter/edit	LRAPDIS
Disease (SNOMED) reference print	LRAPDP
Prisoner of war veterans	LRAPDPT
Disease (SNOMED) reference	LRAPDR
Supplementary Report, Anat Path	LRAPDSR
Spec Studies-EM;Immuno;Consult;Pic, Anat Path	LRAPDSS
Edit/modify data, anat path	LRAPE
Edit log-in & clinical hx, anat path	LRAPED
Edit anat path comments	LRAPEDC
Display EM reports for a patient	LRAPEMCUM
Print electron microscopy report for a patient	LRAPEMSGL
Etiology (SNOMED) reference print	LRAPEP
Etiology (SNOMED) reference	LRAPER
Etiology (SNOMED) enter/edit	LRAPETI
Print final path reports by accession #	LRAPFICH
Function (SNOMED) reference print	LRAPFP
Function (SNOMED) reference	LRAPFR
Function (SNOMED) enter/edit	LRAPFUN
Histopathology Worksheet	LRAPH

Exported Options

Edit pathology parameters	LRAPHDR
Inquiries, anat path	LRAPI
ICD9CM coding, anat path	LRAPICD
Incomplete reports, anat path	LRAPINC
Delete accession #, anat path	LRAPKILL
Log-in menu, anat path	LRAPL
Anatomic pathology labels	LRAPLBL
Log-in, anat path	LRAPLG
Medical journal file edit	LRAPLIB
Anat path slide labels	LRAPLM
Anat path specimen labels	LRAPLS
Modify anat path gross/micro/dx/frozen section	LRAPM
Clinician options, anat path	LRAPMD
Print path modifications	LRAPMOD
Morphology (SNOMED) enter/edit	LRAPMOR
Morphology (SNOMED) reference print	LRAPMP
Morphology (SNOMED) reference	LRAPMR
Move anatomic path accession	LRAPMV
Occupation (SNOMED) enter/edit	LRAPOCC
Enter old anat path records	LRAPOLD
Occupation (SNOMED) reference print	LRAPOP
Occupation (SNOMED) reference	LRAPOR
Print, anat path	LRAPP
Display final path reports by accession #	LRAPPA
Anat path accession list by date	LRAPPAD
Anat path accession list by number	LRAPPAN
Anat path accession reports	LRAPPAR
Entries by dates, patient & accession #	LRAPPF
Persian gulf veterans	LRAPPG
Procedure (SNOMED) reference print	LRAPPP
Procedure (SNOMED) reference	LRAPPR
Procedure (SNOMED) enter/edit	LRAPPRO
List pathology reports in print queue	LRAPQ
AP quality assurance	LRAPQA
Cum path summaries for quality assurance	LRAPQAC
QA codes entry/edit	LRAPQACD
AP consultation searches and reports	LRAPQACN
Delete TC and QA codes	LRAPQADEL
Frozen section, surgical path correlation	LRAPQAFS
Print path micro modifications	LRAPQAM
Malignancy review	LRAPQAMR
10% random case review, surg path	LRAPQAR
Edit QA site parameters	LRAPQASP
Tissue committee review cases	LRAPQAT
QA outcome review cases	LRAPQOR
Verify/release reports, anat path	LRAPR
SNOMED field references	LRAPREF
Pathology reports for a patient	LRAPRPT
Supplementary report release, anat path	LRAPRS
Accession list with stains	LRAPSA
DISEASE code search, SNOMED	LRAPSD
ETIOLOGY code search, SNOMED	LRAPSE
Search options, anat path	LRAPSEARCH
MULTIAXIAL code search, SNOMED	LRAPSEM
FUNCTION code search, SNOMED	LRAPSF
Print a pathology report for a patient	LRAPSGL
ICD9CM code search	LRAPSI
MORPHOLOGY code search, SNOMED	LRAPSM

Enter/edit items in a SNOMED field	LRAPSNOMEDIT
PROCEDURE code search, SNOMED	LRAPSP
Display surg path reports for a patient	LRAPSPCUM
Blocks, Stains, Procedures, anat path	LRAPSPDAT
Print surgical pathology report for a patient	LRAPSPSGL
Enter/edit SNOMED file references	LRAPSRE
Print references for a SNOMED entry	LRAPSRP
Display stains/blocks for a patient	LRAPST
Supervisor, anat path	LRAPSUPER
Cum path data summaries	LRAPT
Topography (SNOMED) enter/edit	LRAPTOP
Topography (SNOMED) reference print	LRAPTP
Topography (SNOMED) reference	LRAPTR
Anatomic pathology turnaround time	LRAPTT
List of unverified pathology reports	LRAPV
Verify/release menu, anat path	LRAPVR
Workload, anat path	LRAPW
EM scanning and photo workload	LRAPWE
Cytopathology screening workload	LRAPWR
Surg path gross assistance workload	LRAPWRSP
SNOMED coding, anat path	LRAPX
Autopsy pathology	LRAU
Data entry, Autopsy Path	LRAUDA
Autopsy protocol & ICD9CM coding	LRAUDAA
Autopsy protocol & SNOMED coding	LRAUDAB
SNOMED coding, Autopsy Path	LRAUDAC
ICD9CM coding, Autopsy Path	LRAUDAI
Autopsy protocol	LRAUDAP
Delete autopsy protocols by date	LRAUDAR
Special studies, Autopsy	LRAUDAS
Final Autopsy Diagnoses Date	LRAUFAD
Log-in, Autopsy path	LRAULG
Autopsy Slide Labels (generic)	LRAUMLK
Print option, Autopsy path	LRAUP
Blood bank	LRBL
Blood Bank Administrative Data	LRBLA
Crossmatch/Transfusions by Specialty/Physician	LRBLAA
Print data change audits	LRBLAD
Remove data change audits	LRBLAR
Inventory ABO/Rh re-check counts	LRBLC
Blood bank consultation reports	LRBLCN
Donor	LRBLD
Donor collection/deferral edit	LRBLDA
Apheresis donor list	LRBLDAP
Acknowledge donor award by deletion	LRBLDAWARD
Donor collection/processing	LRBLDC
Collection disposition report	LRBLDCD
Collection disposition/component preparation	LRBLDCP
Component preparation report	LRBLDCR
Cumulative donations and awards	LRBLDCU
Edit donor consent	LRBLDCX
Donor demographics	LRBLDD
Gallon donor report	LRBLDDA
ABO/Rh testing of donor units	LRBLDDAT
Donor unit testing worklist	LRBLDDAW
Donor deferral report	LRBLDDR
Blood donor group/type edit	LRBLDEDIT
Emergency donor report	LRBLDEDR

Exported Options

Permanent deferral/special comments	LRBLDEF
Print ex-donors	LRBLDEX
First time blood donors	LRBLDFD
Group affiliation report	LRBLDGA
Group donation report	LRBLDGDR
Remove ex-donors	LRBLDK
Donor lists/labels/letters	LRBLDL
Donor registration	LRBLDLG
Enter/edit donor letters	LRBLDLT
Mobile (Collection Site) report	LRBLDMC
Donor month/holiday recall list	LRBLDMR
Old blood donor records	LRBLDO
Patient credits from blood donations	LRBLDPCR
Permanent donor deferral report	LRBLDPD
Donor phenotyping	LRBLDPH
List of donors by last attempt date	LRBLDPL
Blood product rejection report	LRBLDPRR
Donor history, physical and consent form	LRBLDR
Blood donor recruitment reports	LRBLDRPTS
Test review/Component labeling/release	LRBLDRR
Donor scheduling report	LRBLDSC
Donor short draw report	LRBLDSD
Donor summary reports	LRBLDSR
Lab tests(not ABO/Rh) on donor units	LRBLDT
Abnormal donor tests	LRBLDTA
Donor unit testing prooflist	LRBLDTR
Donor unit supplemental testing prooflist	LRBLDTRS
Donor blood testing/review/release	LRBLDU
Donor unit ABO/Rh recheck	LRBLDUC
Edit blood bank files	LRBLEF
Inventory	LRBLI
CMV Antibody Status Report	LRBLICV
Disposition -not transfused	LRBLIDN
Disposition -relocation	LRBLIDR
Disposition-not transfused	LRBLIDU
Blood bank inventory integrity report	LRBLII
Unit CAUTION tag labels	LRBLILA
Log-in regular (invoices)	LRBLILR
Enter blood inventory typing charges	LRBLILS
Phenotyped units available	LRBLIPH
Single unit information- display	LRBLIPSD
Single unit information- print	LRBLIPSP
Transfusion reactions report	LRBLIPTR
Unit issue book entries	LRBLIRB
Blood inventory status reports	LRBLIS
Shipping invoices for blood components	LRBLISH
Transfusion data report	LRBLITR
Transfusions by treating specialty/physician	LRBLITS
Blood inventory transaction reports	LRBLITX
Unit ABO/Rh confirmation	LRBLIUC
Unit phenotyping	LRBLIUP
Units release to stock (cancel) by patient	LRBLIUR
Blood utilization & summary reports	LRBLIUS
Inventory ABO/Rh testing worksheet	LRBLIW
Units on Xmatch by date/time xmatched	LRBLIX
Autologous disposition report	LRBLJB
Edit pooled blood product	LRBLJM
Transfused RBC for treating specialty	LRBLJUT

Blood bank patient	LRBLP
Add BB patient(s) to report queue	LRBLP ADD
Delete BB report print queue	LRBLP DELETE
Print all BB patient reports on print queue	LRBLP PRINT ALL ON QUEUE
Print single BB patient report	LRBLP PRINT SINGLE
Antibodies by patient	LRBLPAB
Patient accession list	LRBLPAL
Blood bank tests report	LRBLPBR
Request/select/xmatch blood components	LRBLPC
Patient transfusions & hematology results	LRBLPCH
Blood component requests	LRBLPCS
Pediatric unit preparation	LRBLPED
Patient ABO/Rh edit	LRBLPEDIT
Previous records	LRBLPER
Enter test data	LRBLPET
Patient Medication List	LRBLPH
Select units for patients	LRBLPIC
Prolonged transfusion times	LRBLPIT
Specimen log-in	LRBLPLOGIN
File 81 conversion	LRBLPOST
Patient antibody report (short list)	LRBLPR
Patient antibody report (long-list)	LRBLPRA
Inappropriate transfusion requests report	LRBLPRIT
Special instructions	LRBLPSI
Blood transfusion results	LRBLPT
Unknown unit transfusion reaction	LRBLPTXR
Enter crossmatch results	LRBLPX
Inquiries	LRBLQ
Patient blood bank record	LRBLQDR
Units assigned/components requested	LRBLQPR
Single donor information	LRBLQSD
Single donor demographic information	LRBLQSDD
Single unit status	LRBLQST
Single unit (display/print) information	LRBLQSU
Reports	LRBLR
Crossmatch:Transfusion report	LRBLRCT
Supplier invoices (inventory)	LRBLRIN
Special typing charges (inventory)	LRBLRIS
Supplier transactions (inventory)	LRBLRIT
Test counts by location	LRBLRTC
Units available (indate/no disposition)	LRBLRUA
Print units with final disposition	LRBLRUF
Units with no disposition	LRBLRUN
Blood bank workload reports	LRBLRWK
Supervisor	LRBLS
Blood donor edit options	LRBLSD
Delete a user's patient list	LRBLSDPL
Edit blood product file	LRBLSEB
Edit unit - patient fields	LRBLSEC
Edit unit disposition fields	LRBLSED
Free autologous/directed donor units	LRBLSEE
Edit blood bank descriptions file	LRBLSEF
Edit donor history questions	LRBLSEH
Edit unit log-in	LRBLSEL
Remove units with final disposition	LRBLSER
Tests for inclusion in transfusion report	LRBLSET
Edit blood bank utility file	LRBLSEU
Edit number of lines in a label	LRBLSF

Exported Options

Blood bank inventory edit options	LRBLSI
Edit lab letter file	LRBLSLL
Maximum surgical blood order edit	LRBLSMS
Edit Corresponding Antigen/Antibody	LRBLSNO
Blood bank patient edit options	LRBLSP
Edit previous transfusion record	LRBLSPP
Remove inappropriate transfusion requests	LRBLSRI
Blood component request edit	LRBLSRQ
Edit blood bank site parameters	LRBLSPP
Summary and deletion reports	LRBLSRQ
Tests for display on patient look-up	LRBLSSR
Blood bank workload	LRBLST
Transfusion reaction count	LRBLSW
Test worklist	LRBLTA
Tests for transfusion follow-up	LRBLTTW
Transfusion follow-up tests	LRBLTX
Blood bank validation documentation	LRBLTXA
Validation documentation	LRBLVAL
Print blood bank validation	LRBLVALI
Ward	LRBLVALP
Add a new WKLD code to file	LRBLW
RCS-CDR/LMIP REPORT	LRCAP CODE ADD
Workload code list	LRCAPAM5
WKLD log file download	LRCAPD
Etiology WKLD Codes (Force)	LRCAPDL
Workload Statistics by Major Section	LRCAPF
Workload cost report by major section	LRCAPMA
Workload Report	LRCAPML
Treating Specialty Workload Report	LRCAPR1
Delete entire order or individual tests	LRCAPTS
Review by order number	LRCENDEL
Check files for inconsistencies	LRCENLKUP
Check patient and lab data cross pointers	LRCHKFILES
Audit of deleted/edited comments	LRCKPTR
Remove an accession	LRDCOM
Edit atomic tests	LRDELOG
Edit cosmic tests	LRDIEATOMIC
Graph results	LRDIECOSMIC
Ward collection summary for lab orders	LRDIST
Enter/verify/modify data (manual)	LRDRAW
Test description information	LRRENTER
Bypass normal data entry	LREV
Fast Bypass Data Entry/Verify	LRFAST
General report for selected tests	LRFASTS
Group unverified review (EA, EL, EW)	LRGEN
Group verify (EA, EL, EW)	LRGP
Group data review (verified & EM)	LRGV
Information-help menu	LRGVP
Clear instrument/worklist data	LRHELP
Reprint order accession label(s)	LRINSTCLR
Reprint accession label(s)	LRLABXOL
Lab liaison menu	LRLABXT
	LRLIAISON
Summary list (extended supervisors')	LRLISTE
Build a load/work list	LRLI
Edit control placement on load/work list	LRLI CONTROLS
Set new "starting sequence number"	LRLI NEW 1ST SEQUENCE #
Change Load/Work list type.	LRLI TYPE

Unload Load/Work List	LRLLECT
Edit the default parameters Load/Work list.	LRLLE DFT
Edit the Load/Work list profile	LRLLE PRO
Insert a Sample on a Load/Work list	LRLINST
Move a Load/Work list entry	LRLMOVE
Print a load/work list	LRLLP
Active Load Work Listing	LRLPA
Remove a Load/Work list entry	LRLREMV
Laboratory DHCP Menu	LRMENU
Microbiology menu	LRMI
Long form accession list for microbiology	LRMIACC1
Batch accessioning	LRMIBL
Accessioning, standard (Microbiology)	LRMICROLOGIN
Results entry	LRMIEDZ
Verification of data by tech	LRMINPWD
Microbiology print menu	LRMIP
Cumulative patient report	LRMIPC
All results for selected accessions	LRMIPLG
Patient report	LRMIPSZ
References	LRMIREF
Enter/Edit medical journal references	LRMIREF JOURNAL
Enter/Edit micro journal references	LRMIREF MICRO
Inquire to micro journal references	LRMIREF MICRO I
Infection control survey report	LRMISEZ
Results entry (batch)	LRMISTUF
Microbiology Trend Report	LRMITS
Verification of data by supervisor	LRMIVER
Re-index Antimicrobial Suscept File (62.06)	LRMIXALL
List of orders not collected (Long form)	LRNDLST
Set a new starting accession number	LRNEWSTART
List of lab orders not collected	LRNODRAW
Special test accessioning	LRNONCOM
Purge old orders & accessions	LROC
Accessioning tests ordered by ward order entry	LROE
Documentation for lab options	LROPT
Listing of Laboratory Menus/Options	LROPTLST
Order/test status	LROS
Lab test order	LROW
Fast lab test order (IMMEDIATE COLLECT)	LROW IMMED COLLECT
Fast lab test order (ROUTINE)	LROW ROUTINE
Fast lab test order (SEND PATIENT)	LROW SEND PAT
Fast lab test order (WARD COLLECT)	LROW WARD COL
Reprint a Ward Collect Order	LROWRP
Receipt of routine lab collection from wards	LRPHEXCPT
Itemized routine lab collection	LRPHITEM
Print collection list/labels	LRPHLIST
Add to collection list	LRPHMAN
Quality control display (Levey-Jennings)	LRQC
Add/edit QC name &/or edit test means	LRQCADDNAME
Bull algorithm quality control	LRQCC
Manually accession QC, Environmental, etc.	LRQCLOG
Quality control menu	LRQCM
Multipurpose accessioning	LRQUICK
Interim report by provider	LRRD
Interim reports for 1 provider (manual queue)	LRRD BY MD
Interim report	LRRP2
Interim report for selected tests	LRRP3
Lab orders by collection type	LRRP5

Exported Options

Detail workload report	LRRP6
Workload statistics by accession area and shift	LRRP8
Interim reports by location (manual queue)	LRRS
Interim reports for 1 location (manual queue)	LRRS BY LOC
Interim report for selected tests as ordered	LRRSP
Flagged Specimens	LRSMAC3
Run Smac	LRSMAC5
Halt Smac Run	LRSMAC6
Smac Support menu	LRSMACMENU
Search for high/low values of a test	LRSORA
Search for critical value flagged tests	LRSORC
Search for abnormal and critical flagged tests	LRSORD
Manual Enter Clinic Stop Codes	LRSTOPC
Batch data entry (chem, hem, tox, etc.)	LRSTUF
Supervisor reports	LRSUPER REPORTS
Supervisor menu	LRSUPERVISOR
SUPERVISOR'S SUMMARY REPORT FOR TASKMAN	LRTASK ACS
LOAD CONTROLS ON THE ACCESSION LISTS.	LRTASK CONJAM
TASK THE CUMULATIVE TO RUN EACH NITE	LRTASK CUM
TASK CUMULATIVE FILEROOM REPORT	LRTASK CUM FILEROOM
QUEUED INTERIM DAILY REPORT (FIRST)	LRTASK DAILY INTERIM 1
QUEUED INTERIM DAILY REPORT (SECOND)	LRTASK DAILY INTERIM 2
Patient Lab Discharge Summary	LRTASK DISCHARGE
START-UP THE BACK GROUND 'LAB' ROUTINE	LRTASK LAB
NIGHTLY CLEANUP	LRTASK NIGHTY
CREATE NEW COLLECTION LIST	LRTASK PHSET
CREATE NEW COLLECTION LIST	LRTASK PHSET1
CREATE A COLLECTION LIST	LRTASK PHSET2
ROLLOVER ACCESSION	LRTASK ROLLOVER
Inquiry to LAB TEST file	LRTESTDIQ
Delete test from an accession	LRTSTOUT
Print accession list(s)	LRUAC
File list for lab	LRUCONTENTS
Changes in verified lab data	LRUER
Print future collection labels	LRUFCL
Print single future collection label	LRUFCLS
Outline for one or more files	LRUFILE
Print/display preselected lab tests	LRUMD
Edit/print/display preselected lab tests	LRUMDA
Delete user selected lab test/patient lists	LRUMDD
Enter/edit user defined lab test lists	LRUMDE
Enter/edit predefined lab test lists	LRUMDL
User selected lab test/patient list edits	LRUMDLM
Accession list by number	LRUPA
Lab accession and test counts	LRUPAC
Accession and test counts by shift	LRUPACS
Test counts by treating specialty	LRUPACT
Accession list by date	LRUPAD
Show list of accessions for a patient	LRUPT
Print group user manual	LRUPUM
Edit group user manual	LRUPUME
Edit referral patient file	LRUV
Accession area worklist	LRUW
Display workload for an accession	LRUWL
Enter/verify data (auto instrument)	LRVR
Enter/verify data (Work list)	LRVRW
Enter/verify data (Load list)	LRVRW2

Ward lab menu	LRWARDM
Incomplete test status report	LRWRKINC
Add a new data name	LRWU5
Modify an existing data name	LRWU6
Add a new internal name for an antibiotic	LRWU7
Update Lab protocols for OE/RR	LRX0
Update ALL lab protocols	LRX1
Update protocol for a single lab test	LRX2
Update protocols for all lab tests	LRX3
Update protocols for all accession groups	LRX4
Update protocols for single accession group	LRX5
OE/RR interface parameters	LRXOSX
Inquire to a Lab administration schedule	LRXOSX0
Edit a lab administration schedule	LRXOSX1
Edit HOSPITAL SITE parameters	LRXOSX2
LABORATORY TEST MENU	LRXQ1

Distribution of Menus

The Laboratory package menus consists of 11 main areas. Each Laboratory may reorganize the order and grouping of menus according to its specific needs and work flow.

Laboratory Options [LRMENU]

1. Phlebotomy menu [LR GET]
2. Accessioning menu [LR IN]
3. Process data in lab menu [LR DO!]
4. Quality control menu [LRQCM]
5. Results menu [LR OUT]
6. Information-help menu [LRHELP]
7. Ward lab menu [LRWARDM]
8. Anatomic pathology [LRAP]
9. Blood bank [LRBL]
10. Microbiology menu [LRMI]
11. Supervisor menu [LRSUPERVISOR]

Menus with Entry or Exit Action

Listed below are Laboratory V. 5.2 menus that contain entry or exit action:

NAME: LR IN MENU TEXT: Accessioning menu
ENTRY ACTION: D ^LRPARAM

NAME: LRWARDM MENU TEXT: Ward lab menu
ENTRY ACTION: D ^LRWD, ^LRPARAM

NAME: LRAP MENU TEXT: Anatomic pathology
ENTRY ACTION: S IOP="HOME" D ^%ZIS W @IOF,?28,"ANATOMIC
PATHOLOGY MENU"

NAME: LRBL MENU TEXT: Blood bank
ENTRY ACTION: S IOP="HOME" D ^%ZIS W @IOF,?35,"BLOOD BANK"

NAME: LRMI MENU TEXT: Microbiology menu
EXIT ACTION: K A,Z

NAME: LRMENU MENU TEXT: Laboratory DHCP Menu
ENTRY ACTION: D ^LRPARAM EXIT ACTION: D ^LRKILL

Security Keys

Each user of the Laboratory package must have the appropriate keys assigned before accessing the Lab package. The SECURITY KEY file (#19.1) contains the key names and a short description. You will need to enter the users names under each of the appropriate key names. Following is a list of the Lab keys:

KEY	USERS
LRANAT	Anatomic Pathology users
LRAPSUPER	Anyone allowed to use the Anatomic Pathology Supervisor Menu and edit SNOMED codes
LRAU	Autopsy Module users
LRBLOODBANK	Blood Bank users
LRBLSUPER	For Blood Bank supervisory level decisions
LRCY	Cytology Module users
LREM	Electron Microscopy Module users
LRLAB	Laboratory Personnel only
LRLIASON	Laboratory Information Manager
LRMICRO	Microbiology users
LRMIVERIFY	Microbiology personnel
LRSP	Surgical Pathology Module users
LRSUPER	Laboratory Supervisors
LRVERIFY	Anyone who is authorized to verify lab results
LRPHMAN	Phlebotomists
LRPHSUPER	Supervisor of the phlebotomy collection team

Any combination of the above security levels may be used, as deemed appropriate by the Laboratory.

Individual Module Requirements/Concerns

Anatomic Pathology

In addition to the LRLAB and LRVERIFY security keys, the Anatomic Pathology module requires several specific keys to access the appropriate accession areas and options which should be limited to supervisory level or experience personnel.

LRLANAT	Anatomic Pathology users*
LRAUAutopsy	Autopsy Module users*
LRCYCytology	Cytology Module users*
LREM	Electron Microscopy Module users*
LRSP	Surgical Pathology Module users*
LRAPSUPER	Allows anyone to use the Anatomic Pathology Supervisor Menu and edit SNOMED codes
LRSUPER	Laboratory Supervisors

Since the various options, excluding those in the Supervisor menu, do not require specific security keys once you have the appropriate accession area keys, regulating access to the options must be accomplished via strict menu management.

Blood Bank

In addition to the LRLAB and LRVERIFY security keys, the Blood Bank Module requires only the LRBLOODBANK key to access the majority of the options. The LRBLSUPER key is, however necessary to access all of the options in the Supervisor's Menu, as well as to release incompatible blood using the Disposition-relocation [LRBLIDR] option in the Inventory Menu.

Since the various options, excluding those in the Supervisor's menu, do not require specific security keys, regulating access to the options must be accomplished via strict menu management. Menus must be constructed at each site, tailored to the actual needs of the individuals using the module.

Chemistry/Immunology

The Chemistry subscript Module requires the LRLAB and LRVERIFY security keys to access the majority of the options. The LRSUPER key is necessary to access the options in the Supervisor's Menu.

Microbiology

In addition to the LRLAB and LRVERIFY security keys, the Microbiology Module requires only the LRMICRO key to access the majority of the options and to release results. The LRSUPER key is necessary to access the options in the Microbiology Supervisor Menu,

Phlebotomy

The phlebotomy section requires the LRLAB key to access the necessary options. The LRPHSUPER key is, however, necessary to access the options needed by the Phlebotomy supervisor.

LRTASK Options

These options are designed to be scheduled through TaskMan.

<u>OPTION</u>	<u>ROUTINE</u>	<u>DESCRIPTION</u>
LRTASK ACS	LRACS	Supervisor's daily summary report based on File #64.5. The format is by location, by patient. If a summary is desired by accession number, use the LR SUP SUMMARY option. The LR SUP SUMMARY option is more comprehensive and bulkier. This option should be chosen only if the job failed to run.
LRTASK CONJAM	LRCONJAM	Run by TaskMan each night to set up the controls for the accession list.
LRTASK CUM	CL2^LRAC	Function automatically run by TaskMan. This function should only be selected if the job failed to start. Any other reprints or reruns of any part of the cumulative should be initiated via one of the reprint options in the cumulative menu. Various versions of this option can be created if multiple devices are used to print the cumulative.
LRTASK CUM FILEROOM	CLOCK^LRACFR	This option is used to print file room cumulative patients. This option determines the last time the file room patients were printed. It then identifies all file room patients that require printing since the last run and move those entries to the current list of cumulative file room patients. Finally it queues a task to print these patients to specified printers. When the LAB

REPORTS file has been properly set, this option will allow the printing of the file room cum on a different schedule than in patient cums.

LRTASK DAILY INTERIM 1	AIDQ^LRRP2	MenuMan queue option for the first daily interim cumulative report.
LRTASK DAILY INTERIM 2	AIDQ^LRRP2	Same as LRTASK DAILY INTERIM 1.
LRTASK DISCHARGE	DQ^LRACSUM	For automatic queuing of a Laboratory discharge summary for patients discharge T-1 from the date this option is invoked. The report is in a similar format as the full patient summary and the cumulative report. The only results that are printed are those that are ordered from the date of admission to the date of discharge.
LRTASK LAB	DQ^LAB	Option to be used by the TaskMan to start up the background LAB routine each time the system is started from a boot.
LRTASK NIGHTY	LRNIGHT	Routine run nightly by TaskMan to do some lab cleanup.
LRTASK PHSET	LRPHSET	Routine run each day by TaskMan to create the collection list.
LRTASK PHSET1	LRPHSET	Routine run each day by TaskMan to create the collection list.
LRTASK ROLLOVER	LROLOVER	Routine run each night by TaskMan to roll forward the unverified accessions.

CROSS REFERENCES

Cross References

Cross References

The cross references are grouped by files. The field affected is identified along with the cross reference name or number, if there is no name.

Select FILE: 60 LABORATORY TEST

XREF	DD	FLD NUM	FIELD NAME
* "AB"	60.02	.01	LAB TEST
* "B"	60	.01	NAME
* "C"	60	5	LOCATION (DATA NAME)
* "D"	60	51	PRINT NAME

Select FILE: 61 TOPOGRAPHY FIELD

XREF	DD	FLD NUM	FIELD NAME
* "B"	61	.01	NAME
* "C"	61	2	SNOMED CODE
* "D"	61.01	.01	SYNONYM
* "E"	61	6	ABBREVIATION

Select FILE: 61.1 MORPHOLOGY FIELD

XREF	DD	FLD NUM	FIELD NAME
* "B"	61.1	.01	NAME
* "C"	61.1	2	SNOMED CODE
* "D"	61.11	.01	SYNONYM

Select FILE: 61.2 ETIOLOGY FIELD

XREF	DD	FLD NUM	FIELD NAME
* "B"	61.2	.01	NAME
* "C"	61.22	.01	SYNONYM
* "D"	61.2	2	SNOMED CODE
* "E"	61.23	.01	*BIOCHEMICAL WORKUP

Select FILE: 61.3 FUNCTION FIELD

XREF	DD	FLD NUM	FIELD NAME
* "B"	61.3	.01	NAME
* "C"	61.3	2	SNOMED CODE
* "D"	61.31	.01	SYNONYM
* "E"	61.3	4	IDENTIFIER

Cross References

Select FILE: 61.4 DISEASE FIELD

	XREF	DD	FLD NUM	FIELD NAME
*	"B"	61.4	.01	NAME
*	"C"	61.4	2	SNOMED CODE
*	"D"	61.41	.01	SYNONYM

Select FILE: 61.5 PROCEDURE FIELD

	XREF	DD	FLD NUM	FIELD NAME
*	"B"	61.5	.01	NAME
*	"C"	61.5	2	SNOMED CODE
*	"D"	61.51	.01	SYNONYM

Select FILE: 61.6 OCCUPATION FIELD

	XREF	DD	FLD NUM	FIELD NAME
*	"B"	61.6	.01	NAME
*	"C"	61.6	2	SNOMED CODE
	"D"	61.61	.01	SYNONYM

Select FILE: 62 COLLECTION SAMPLE

	XREF	DD	FLD NUM	FIELD NAME
*	"B"	62	.01	NAME
*	"C"	62	3	TUBE TOP COLOR
*	"D"	62.01	.01	SYNONYM

Select FILE: 62.05 URGENCY

	XREF	DD	FLD NUM	FIELD NAME
*	"B"	62.05	.01	URGENCY

Select FILE: 62.06 ANTIMICROBIAL SUSCEPTIBILITY

	XREF	DD	FLD NUM	FIELD NAME
	"AC"	62.06	1	DRUG NODE
*	"AD"	62.06	1	DRUG NODE
	"AF"	62.06	6	ABBREVIATION
*	"AI"	62.06	1	DRUG NODE
*	"AJ"	62.06	1	DRUG NODE
*	"AO"	62.06	.5	PRINT ORDER
*	"AS"	62.06	1	DRUG NODE
*	"B"	62.06	.01	NAME
*	"C"	62.06	5	INTERNAL NAME
*	"D"	62.06	6	ABBREVIATION

Select FILE: 62.07 EXECUTE CODE

XREF	DD	FLD NUM	FIELD NAME
"AC"	62.07	5	SUBSCRIPT NAME
* "B"	62.07	.01	NAME

Select FILE: 62.1 DELTA CHECKS

XREF	DD	FLD NUM	FIELD NAME
* "B"	62.1	.01	NAME

Select FILE: 62.3 LAB CONTROL NAME

XREF	DD	FLD NUM	FIELD NAME
"AC"	62.3	.01	NAME
* "B"	62.3	.01	NAME

Select FILE: 62.4 AUTO INSTRUMENT

XREF	DD	FLD NUM	FIELD NAME
* "AC"	62.4	100	METH NAME
"AD"	62.4	3	LOAD/WORK LIST
"AS"	62.4	5	ENTRY for LAGEN ROUTINE
* "B"	62.4	.01	NAME
* "C"	62.4	2	PROGRAM
* "D"	62.4	10	METHOD

Select FILE: 62.5 LAB DESCRIPTIONS

XREF	DD	FLD NUM	FIELD NAME
* "AC"	62.5	.01	NAME
* "AD"	62.5	5	SCREEN
* "B"	62.5	.01	NAME

Select FILE: 62.55 AGGLUTINATION STRENGTH

XREF	DD	FLD NUM	FIELD NAME
* "B"	62.55	.01	NAME
* "C"	62.55	1	WILL STAND FOR

Select FILE: 62.6 ACCESSION TEST GROUP

XREF	DD	FLD NUM	FIELD NAME
* "B"	62.6	.01	ACCESSION TEST GROUP

Cross References

Select FILE: 63 LAB DATA

	XREF	DD	FLD NUM	FIELD NAME
*	"AAU"	63	11	AUTOPSY DATE/TIME
*	"AAUA"	63	14	AUTOPSY #
*	"AB"	63.017	.11	TRANSFUSION REACTION TYPE
	"AC"	63.34	.01	PARASITE
*	"ACY"	63.09	.1	DATE/TIME SPECIMEN RECEIVED
*	"ACYA"	63.09	.06	ACCESSION #
	"AD"	63.3	.01	ORGANISM
	"AE"	63.37	.01	FUNGUS/YEAST
*	"AEM"	63.02	.1	DATE/TIME SPECIMEN RECEIVED
*	"AEMA"	63.02	.06	ACCESSION #
	"AF"	63.39	.01	MYCOBACTERIUM
	"AG"	63.43	.01	VIRUS
*	"AR"	63.0171	.02	TRANSFUSION REACTION TYPE
*	"ASP"	63.08	.1	DATE/TIME SPECIMEN RECEIVED
*	"ASPA"	63.08	.06	SURGICAL PATH ACC #
	"AZZ"	63	.02	PARENT FILE
*	"B"	63	.01	LRDFN
	"CZZ"	63	.03	NAME

Select FILE: 63.9999 ARCHIVED LR DATA

	XREF	DD	FLD NUM	FIELD NAME
	"AZZ"	63.9999	.02	PARENT FILE
*	"B"	63.9999	.01	LRDFN
	"CZX"	63.9999	.03	NAME
	"CZZ"	63.9999	.03	NAME

Select FILE: 64 WKLD CODE

	XREF	DD	FLD NUM	FIELD NAME
	"AC"	64	15	ACTIVATE WKLD CODE
*	"B"	64	.01	PROCEDURE
*	"C"	64	1	WKLD CODE
*	"D"	64	.01	PROCEDURE
*	"E"	64	1	WKLD CODE
	"F"	64	.04	PRINT NAME
*	"G"	64.019	.01	SYNONYM

Select FILE: 64.05 NON WKLD PROCEDURES

	XREF	DD	FLD NUM	FIELD NAME
*	"B"	64.05	.01	PROCEDURE
*	"C"	64.05	1	WKLD CODE

Select FILE: 64.1 WKLD DATA

XREF	DD	FLD NUM	FIELD NAME
"B"	64.1	.01	INSTITUTION

Select FILE: 64.2 WKLD SUFFIX CODES

XREF	DD	FLD NUM	FIELD NAME
* "AC"	64.2	15	ACTIVATE WKLD CODE
* "B"	64.2	.01	NAME
* "C"	64.2	1	WKLD SUFFIX CODE
* "D"	64.2	11	MANUFACTURER
* "E"	64.2	11	MANUFACTURER
* "F"	64.2	1	WKLD SUFFIX CODE

Select FILE: 64.19999 ARCHIVED WORKLOAD WKLD DATA

XREF	DD	FLD NUM	FIELD NAME
"B"	64.19999	.01	INSTITUTION

Select FILE: 64.21 WKLD CODE LAB SECT

XREF	DD	FLD NUM	FIELD NAME
* "B"	64.21	.01	NAME
* "C"	64.21	1	ABBREV.
* "D"	64.21	2	SYNONYM
* "E"	64.21	.01	NAME

Select FILE: 64.22 WKLD ITEM FOR COUNT

XREF	DD	FLD NUM	FIELD NAME
* "B"	64.22	.01	ABBREV
* "C"	64.22	1	Full Name
* "D"	64.22	1	Full Name

Select FILE: 64.3 WKLD INSTRUMENT MANUFACTURER

XREF	DD	FLD NUM	FIELD NAME
* "B"	64.3	.01	NAME

Cross References

Select FILE: 64.5 LAB REPORTS

	XREF	DD	FLD NUM	FIELD NAME
*	"AC"	64.53	4	TEST LOCATION
*	"B"	64.5	.01	NAME
	"MUMPS5"	64.5	7	REPORT DATE

Select FILE: 64.6 INTERIM REPORTS

	XREF	DD	FLD NUM	FIELD NAME
	"AC"	64.6	600000	EPIC REPORTING
*	"AD"	64.6	3	DEVICE
*	"AI"	64.6	.01	LOCATION
*	"AS"	64.6	1	IMMEDIATELY TRANSMIT RESULTS
	"AS1"	64.6	.01	LOCATION
*	"B"	64.6	.01	LOCATION

Select FILE: 64.7 CUMULATIVE

	XREF	DD	FLD NUM	FIELD NAME
*	"B"	64.7	.01	LRDFN

Select FILE: 65 BLOOD INVENTORY

	XREF	DD	FLD NUM	FIELD NAME
*	"A"	65	.05	DATE/TIME RECEIVED
	"AA"	65.31	.01	COMPLETE DATE/TIME
*	"AB"	65	4.2	DISPOSITION DATE
	"AC"	65	4.1	DISPOSITION
	"AD"	65	10	ABO INTERPRETATION
*	"AE"	65	.06	EXPIRATION DATE/TIME
	"AF"	65	11	RH INTERPRETATION
	"AG"	65	4.1	DISPOSITION
	"AH"	65	.04	COMPONENT
*	"AI"	65	.06	EXPIRATION DATE/TIME
	"AJ"	65	.01	UNIT ID
	"AK"	65	.04	COMPONENT
*	"AL"	65.03	.01	DATE/TIME UNIT RELOCATION
	"AM"	65.01	.01	PATIENT XMATCHED/ASSIGNED
*	"AN"	65.02	.09	DATE/TIME CROSSMATCHED
	"AO"	65	.02	SOURCE
*	"AP"	65.01	.02	DATE/TIME UNIT ASSIGNED
	"APS"	65	4.1	DISPOSITION
	"AQ"	65	.04	COMPONENT
	"AR"	65.15	.08	PREVIOUS DATE LOGGED-IN
*	"AT"	65	.01	UNIT ID
*	"AU"	65	8	RESTRICTED FOR
*	"B"	65	.01	UNIT ID
*	"C"	65	.01	UNIT ID

Select FILE: 65.4 BLOOD BANK UTILITY

XREF	DD	FLD NUM	FIELD NAME
* "B"	65.4	.01	NAME
* "C"	65.4	.03	FULL NAME

Select FILE: 65.5 BLOOD DONOR

XREF	DD	FLD NUM	FIELD NAME
"AA"	65.5991	.01	COMPLETE DATE/TIME
"AC"	65.54	10	ABO INTERPRETATION
* "AD"	65.54	.01	DONATION OR DEFERRAL DATE
"AE"	65.54	11	RH INTERPRETATION
"AF"	65.54	12	SYPHILIS SEROLOGY
"AG"	65.54	13	HBsAg
"AH"	65.54	14	HIV ANTIBODY
"AI"	65.54	15	ANTIBODY SCREEN RESULT
"AJ"	65.54	16	HBcAb
"AK"	65.54	17	ALT
"AL"	65.54	18	HTLV-I ANTIBODY
"AM"	65.54	19	HCV ANTIBODY
* "AT"	65.54	4	UNIT ID
* "B"	65.5	.01	NAME
* "C"	65.54	4	UNIT ID
* "D"	65.54	4	UNIT ID
"E"	65.5	.03	DOB
"F"	65.5	.01	NAME
* "G"	65.5	.13	SSN
* "G4"	65.5	.13	SSN
"G40"	65.5	.01	NAME

Select FILE: 65.9 LAB LETTER

XREF	DD	FLD NUM	FIELD NAME
* "B"	65.9	.01	NAME

Select FILE: 65.9999 ARCHIVED BLOOD INVENTORY

XREF	DD	FLD NUM	FIELD NAME
"A"	65.9999	.05	DATE/TIME RECEIVED
"AA"	65.999931	.01	COMPLETE DATE/TIME
"AB"	65.9999	4.2	DISPOSITION DATE
"AC"	65.9999	4.1	DISPOSITION
"AD"	65.9999	10	ABO INTERPRETATION
"AE"	65.9999	.06	EXPIRATION DATE/TIME
"AF"	65.9999	11	RH INTERPRETATION
"AG"	65.9999	4.1	DISPOSITION
"AH"	65.9999	.04	COMPONENT
"AI"	65.9999	.06	EXPIRATION DATE/TIME
"AJ"	65.9999	.01	UNIT ID
"AK"	65.9999	.04	COMPONENT

Cross References

"AL"	65.999903	.01	DATE/TIME UNIT RELOCATION
"AM"	65.999901	.01	PATIENT XMATCHED/ASSIGNED
"AN"	65.999902	.09	DATE/TIME CROSSMATCHED
"AO"	65.9999	.02	SOURCE
"AP"	65.999901	.02	DATE/TIME UNIT ASSIGNED
"APS"	65.9999	4.1	DISPOSITION
"AQ"	65.9999	.04	COMPONENT
"AR"	65.999915	.08	PREVIOUS DATE LOGGED-IN
"AT"	65.9999	.01	UNIT ID
"AU"	65.9999	8	RESTRICTED FOR
"B"	65.9999	.01	UNIT ID
"C"	65.9999	.01	UNIT ID

Select FILE: 66 BLOOD PRODUCT

	XREF	DD	FLD NUM	FIELD NAME
*	"B"	66	.01	NAME
*	"C"	66	2	SYNONYM
*	"D"	66	.05	PRODUCT CODE

Select FILE: 66.5 OPERATION (MSBOS)

	XREF	DD	FLD NUM	FIELD NAME
*	"B"	66.5	.01	NAME

Select FILE: 66.9 BLOOD COMPONENT

	XREF	DD	FLD NUM	FIELD NAME
	"B"	66.9	.01	NAME

Select FILE: 67 REFERRAL PATIENT

	XREF	DD	FLD NUM	FIELD NAME
*	"B"	67	.01	NAME
*	"C"	67	.09	IDENTIFIER
*	"CN"	67	.1	REFERRAL SOURCE
*	"D"	67	.01	NAME

Select FILE: 67.1 RESEARCH

	XREF	DD	FLD NUM	FIELD NAME
*	"B"	67.1	.01	NAME
*	"C"	67.1	9	IDENTIFIER
*	"D"	67.1	.01	NAME

Select FILE: 67.2 STERILIZER

XREF	DD	FLD NUM	FIELD NAME
"AC"	67.2	.1	LOCATION
* "B"	67.2	.01	NAME
* "C"	67.2	9	IDENTIFIER

Select FILE: 67.3 ENVIRONMENTAL

XREF	DD	FLD NUM	FIELD NAME
* "B"	67.3	.01	NAME
* "C"	67.3	9	IDENTIFIER

Select FILE: 67.4 NON PATIENT WORKLOAD

XREF	DD	FLD NUM	FIELD NAME
"B"	67.4	.01	NAME

Select FILE: 67.9 LAB MONTHLY WORKLOADS

XREF	DD	FLD NUM	FIELD NAME
"B"	67.9	.01	PRIMARY INSTITUTION

Select FILE: 67.99999 ARCHIVED LAB MONTHLY WORKLOADS

XREF	DD	FLD NUM	FIELD NAME
"B"	67.99999	.01	PRIMARY INSTITUTION

Select FILE: 68 ACCESSION

XREF	DD	FLD NUM	FIELD NAME
"AA"	68.04	4	COMPLETE DATE
* "AC"	68.02	13	DATE/TIME RESULTS AVAILABLE
* "AD"	68	.095	*LAB SECTION
* "AE"	68	.04	COMMON ACCESSION #'S WITH AREA
"AMI"	68.04	4	COMPLETE DATE
* "B"	68	.01	AREA

Select FILE: 68.2 LOAD/WORK LIST

XREF	DD	FLD NUM	FIELD NAME
* "B"	68.2	.01	NAME

Cross References

Select FILE: 68.4 WORKLIST HEADINGS

XREF	DD	FLD NUM	FIELD NAME
"B"	68.4	.01	NAME

Select FILE: 69 LAB ORDER ENTRY

XREF	DD	FLD NUM	FIELD NAME
* "AA"	69.01	13	COLLECTION STATUS
"AN"	69.01	21	DATE/TIME RESULTS AVAILABLE
* "B"	69	.01	DATE ORDERED
* "C"	69.01	9.5	ORDER #
* "D"	69.01	.01	LRDFN

Select FILE: 69.1 COLLECTION LIST

XREF	DD	FLD NUM	FIELD NAME
* "B"	69.1	.01	COLLECTION ROUTE
* "LRPH"	69.11	.01	TEST
"LRPH1"	69.11	4	SPECIMEN #

Select FILE: 69.9 LABORATORY SITE

XREF	DD	FLD NUM	FIELD NAME
"AC"	69.9	.01	SITE NAME
* "B"	69.9	.01	SITE NAME

Select FILE: 69.91 LR ROUTINE INTEGRITY CHECKER

XREF	DD	FLD NUM	FIELD NAME
* "B"	69.91	.01	Version #
"C"	69.9113	.01	Patch #

Select FILE: 69.2 LAB SECTION PRINT

XREF	DD	FLD NUM	FIELD NAME
* "B"	69.2	.01	NAME
* "C"	69.2	.02	ABBREVIATION

Select FILE: 95 LAB JOURNAL

XREF	DD	FLD NUM	FIELD NAME
* "B"	95	.01	JOURNAL ABBREVIATION
* "C"	95	.02	FULL NAME

PURGING AND ARCHIVING

Purging and Archiving

Purging And Archiving

Force Cumulative Data to Permanent Page [LRAC FORCE]

The concept of temporary and permanent pages is part of the cumulative design. For pages to be in this format, the cumulative must have been initialized.

One of the eligibility requirements for archiving of laboratory data from the ^LR global assumes that the cumulative is in use and that the 9th piece of ^LR is set to a permanent page designation when a page becomes "full."

Unfortunately, many patients do not have the activity level which will result in a "full" page within a reasonable time frame. In the case of deceased patients, the temporary pages have no mechanism to become permanent since there is no longer any activity for these pages.

This, in conjunction with some site selectable parameters such as not printing cumulatives for either inpatients or outpatients, not initializing the cumulative report, etc., has resulted in increasing disk space requirements by laboratory.

The option Force Cumulative Data to Permanent Page [LRAC FORCE] can be used to set the 9th piece in the ^LR global to a permanent page designation. This option can be used whether or not a cumulative report has printed. By setting the page designation in ^LR, the data is considered to be permanent and eligible for subsequent archiving. Data is not removed from the system until the archiving utilities have been run.

To use the option, the field Grace Period For Inactivity in the LABORATORY SITE file (#69.9) must contain an entry. Each site should establish a reasonable time frame for inactivity (e.g., if a patient has not had any activity - no tests ordered - for 6 months, 2 years, etc., we might want to make it eligible for archiving). The field entry represents the number of days of inactivity.

For those patients who had Force Cumulative Data To Permanent Page [LRAC FORCE] option run for a cumulative report, the page numbers will reflect the last temporary page. There is no reprinting of the cumulative report at this time.

Example: If the last temporary pages to print on SMITH,JOHN were 1:1,2:2,25:1 and there has been no activity on this patient for the grace period for inactivity, the current page designation will be forced into the 9th piece of ^LR global. When the pages are forced to permanent, the ^LR(LRDFN,"PG" node is updated. The next time the patient has data for each of these pages, the pages to print will be 1:2,2:3,25:2.

NOTE: If there has been any data reported within the grace period for any page, the patient data is not forced. Either all pages are forced or no pages are forced.

If the patient results have not been initialized and printed in the cumulative report format, the data is still eligible for forcing to permanent pages. The routine looks at the data in ^LR and determines the major header page for the results. The increment within the major header will be set to "1" for all results, regardless of the amount of data for each of the headers. If this patient subsequently does have a cumulative report printed, the temporary pages will start with the second page increment within the Major Header; i.e., MAJOR HEADER:2 (increment within the major header).

A list of patients is generated during the running of this routine, which will print the LRDFN, patient's name, and pages that were forced to permanent.

The ^LRO(68,"AC" and ^LAC("LRAC" cross references to the data in ^LR(LRDFN,"CH" are also killed off.

NOTE: You may want to stop journaling during the running of this routine, because of the increased amount of journal space used when global nodes are killed.

Purge Old Orders and Accessions [LROC]

Ordering and accession information for those accession areas in ACCESSION file (#68) set up to have a transform of DAILY is purged with this utility option. Data stored in ^LRO(68,"LRAA",^LRO(69,"C", and ^LRO(69,"B" are killed off during the running of this routine. The amount of data retained will be determined by the field GRACE PERIOD FOR ORDERS in File #69.9. Once this data is purged, any option referencing the accession number (e.g., CH 0814 44) or the order number will no longer be accessible. Some examples of options are: EM (Enter/verify/modify data), Review by Order Number, Interim Report for Selected Tests as Ordered.

This option should be run on a regular basis to control the amount of disk space required by laboratory. Your site should determine an appropriate length of time to retain at this type of information. It is recommend that the site retain at least 120 days of accession/orders.

For accession areas (i.e., for referral tests) where the turnaround time may exceed the Grace Period for Orders, consider setting these up for monthly or yearly accession area transform.

Never run this option Purge Old Orders and Accessions [LROC] during peak activity hours since it is system-intensive. A Site Manager may want to disable journaling ^LRO, depending on the amount of data in these files to be purged and the frequency with which the option is run. To purge the data for ^LRO(68,"LRAA" for those Accession areas other than daily, VA FileManager must be used.

Example: Purging of a yearly, quarterly, or monthly Accession area transform deletion.

```
Select OPTION:      E      (ENTER OR EDIT FILE ENTRIES)
INPUT TO WHAT FILE:  OPTION//  68      ACCESSION      (22 entries)
EDIT WHICH FIELD:   ALL//   DATE      (multiple)
                   EDIT WHICH DATE SUB-FIELD:   ALL//   <RET>
THEN EDIT FIELD:    <RET>
```

```
Select ACCESSION AREA:      MICROBIOLOGY
```

```
Select DATE:      1987//   <RET>
DATE:      1987// @
SURE YOU WANT TO DELETE THE ENTIRE DATE?      Y      (YES)
```

NOTES:

1. An answer of "YES" will delete an entire year.
2. Monthly Accession Areas delete entire month.
3. Quarterly Accession Areas delete entire quarter.

Archive of LAB DATA file (#63)

The archive process looks through the LAB DATA file (#63) for data from microbiology (MI), chemistry, urinalysis, hematology, serology, etc., (CH). Any found eligible are copied to the global ^LAR for subsequent processing by the archive utilities.

Eligibility is determined by the following criteria:

- a. Lab determines the minimum retention period. The default is currently T-180. Note that the retention period should be longer than the time the data is saved in the Accession and Order files. Micro data is retained an additional 370 days by the archive search, to accommodate the yearly accession area.
- b. For CH tests, the results must have been printed to a cumulative permanent page. For MI tests, any data older than the retention period is eligible to be archived. Clinic patients with low activity, deceased patients, or any other group with few lab tests ordered will never turn over permanent pages and the current utility will never archive this data. The option, Force cumulative data to permanent page [LRAC FORCE], can be used to set the 9th piece in the ^LR global to a permanent page designation. By setting the page designation in ^LR, the data is considered to be permanent and eligible for subsequent archiving.
- c. Tests for Lab Controls, Research, Environmental, and Reference patients are selected for archive solely on the basis of the retention period.

Archive Options

You reach the archiving options using the following pathway:

```
Supervisor menu [LRSUPERVISOR]
  Lab liaison menu [LRLIASON]
    Archive lab data [LR ARCHIVE MENU]
      1 Search for lab data to archive [LR ARCHIVE SEARCH]
        **> Locked with LRLIASON
      2 Write data to off-line media [LR ARCHIVE WRITE MEDIA]
      3 Clear data from the LAR global [LR ARCHIVE CLEAR]
        **> Locked with LRLIASON
      4 Read data from off-line media [LR ARCHIVE READ MEDIA]
      5 Purge data found in the Search option [LR ARCHIVE PURGE]
        **> Locked with LRLIASON
      6 Find patient's archived data [LR ARCHIVE DATA]
      7 Convert archived data to use New Person file [LR ARCHIVE NP CONVERSION]
      8 Restore archived data to LR global [LR ARCHIVE RESTORE]
```

The six archiving options are listed below in the required sequence for archiving and/or restoring of data (they MUST be run in this order):

NOTE: It is recommended to run Force Cumulative Data to Permanent Page [LRAC FORCE] option before proceeding.

1. **Search for Lab Data to Archive**
Data to be archived should be older than the beginning of the month three months ago. Anatomic Pathology and Blood Bank data are not archived.
2. **Write Data to Off-Line Media**
After having created entries in the ^LAR global, the data should be written to off-line media for purposes of long-term storage. The site manager should determine the method of data storage of the ^LAR global.
3. **Clear data from the LAR global**
Data found in the Search Archive option is removed by this option.
4. **Read Data from Off-Line Media**
After having cleared the ^LAR global, the data should be read back in, to verify and purge what has been archived. The site manager should determine the method of data retrieval of the ^LAR global.
5. **Purge Data Found in the Search Option**
Data found in the Search archive option are stored in the ^LAR global. Note that the data is removed from both the ^LR and the ^LAR globals. This step cannot be run unless step 3 has been done. This step loops through LAR and removes the corresponding entry from the LAB DATA file (#63). Accession nodes are checked before deletion to make sure that nothing has been modified since the search phase. A record is kept in the LAB DATA file (#63) to indicate that this patient has had archived data and to tell which tape has been used.
6. **Find Patient's Archived Data**
Once the archived tape has been restored to the system, a single patient or all patients may be retrieved from that archived tape. Data for a patient which has been archived, the storage location of the data is saved with the patient's remaining entry in the ^LR(global. This information can be found using this option.

7. Convert Archived LR Data

This option is used to convert the data to the NEW PERSON file (#200).

☛ **WARNING:** It is required that this step be performed before any patient data is utilized. Failure to do so will result in various names being incorrect. Patients name in clinical data does not require this conversion process.

8. Restore Archived Data to LR Global

This option is used to restore data into the LR global that has been archived.

NOTES:

1. To reproduce a cumulative for patient data that has been restored from the archives, use the Reprint cumulative on a given patient [LRAC PT] option, and re-initialize the patient's entire cumulative.
2. The physical and logical names you are asked for during the archiving process are meant to be identifiers for you to keep record of archiving processes. They are NOT physical or logical devices (e.g., printer, terminal, etc.).
3. When you restore a patient to the ^LR global, you now have two records. One active on the ^LR global and one archived. When you archive that section of the ^LR global, you will have two archive records on that one patient.

EXTERNAL RELATIONS

External Relations

This section explains special relations and agreements between routines in this package and routines in other packages. It also specifies versions of FileMan, Kernel, and other packages required.

External Referenced Files and Fields

FILES	Fields Used
2 PATIENT Date Of Death, Ward	Name, SSN, Sex, DOD, Current Admission,
19.1 SECURITY KEY	Name
40.5 HOLIDAY	Date
40.8 MEDICAL CENTER DIV.	Version Node
42 WARD LOCATION	Name
42.4 SPECIALTY	PTF Code, Service
4.3 KERNEL SITE	Default Institution Parameters
44 HOSPITAL LOCATION Type	Name, Abbreviation, Treating Specialty,
45 PTF	Procedures, Movement Record
45.7 FACILITY TREATING SPECIALTY	Name
50 DRUG	Generic Name
50.5 DRUG CLASSIFICATION	Name
52 PRESCRIPTION	Drug
55 PHARMACY PATIENT	Prescription Profile
80 ICD DIAGNOSIS	Code Number, Diagnosis
80.1 ICD OPERATION/ PROCEDURE	Code Number Operation Procedure
81 CPT Short Name	Description, Blood Component Request,
81.1 CPT CATEGORY	CPT Category Name
100 ORDER	OERR Internal File#
101 PROTOCOL	(Entire File)
130 SURGERY	Name
200 NEW PERSON	Name
405 PATIENT MOVEMENT	Admission, Discharge, & Transfer

NOTE: Permission has been received from the respective package developers to reference these fields.

External Routines

The Laboratory package makes calls to VA FileMan, MenuMan, MailMan, Pharmacy, OE/RR routines, tools, and utilities supplied through the Kernel software:

%DT	%DTC	%ZIS
%ZTLOAD	%ZOSV	DIC
SDACS	PSJEEU	DIC1
DICD	ORX	DICN
DICQ	XMD	DIE
DIK	XQH	DIM
DIP	XUS	DIQ
DIWP	ZU	DIWW

Two Department of Defense (DoD) routines (IAAPRIV and IAARNUM) are called by the Laboratory software if the variable DUZ ("AG") contains "ARMYAFN."

The DoD MILITARY RANK file is pointed to by the Military Rank field in the BLOOD DONOR file. This file will only exist at DoD sites.

External Variables

The variable DIU(0) is used to determine the manner in which to create or recreate certain cross-references.

Required Software

You must have Kernel V. 7.1 or greater and FileMan V. 20.0 or greater installed and running before Laboratory V. 5.2 can be used. The current MAS V. 5.2 or greater should also be installed. The LAB JOURNAL file (#95) is also required by the Microbiology module. If Lab is installed in an agency other than the Veterans Administration (as defined by the Agency code field in the KERNEL SITE PARAMETER file), the routines IAAPRIV and IAARNUM may be required for DoD Sites.

Package	Versions (or Greater)
Kernel	7.1
FileMan	20.0
MAS	5.3
Laboratory (if already resident)	5.1
OE/RR	2.5
AMIE	2.5
Inpatient Medication	3.2

DBA Integration Agreements

LIMs and IRM personnel need to be aware of the fields controlled by Lab that affect other programs BEFORE they make any programming changes. To obtain the most current listing, the DBA menu is located on Forum under secondary options.

Example:

Select Mailman Menu Option: **DBA**

Select DBA Option: ?

- 1 List Package file by Name
- 2 List Package file by Prefix
- 3 Find lo-high range of filenumbers
- 4 Package file inquire
- 5 Package file inquire by #
- 6 Institution file inquire
- 7 SACC Exemptions ...
- 8 Supported references (DBIC library) ...
 - **> Out of order: Replaced by 'Integration Agreements Menu'
- 9 Projected releases
- 10 Domain file inquire
- 11 Integration Agreements Menu ...
- 12 Standards and Conventions
- 13 MOP-UP ...
- 14 Quarterly Briefing Report by season
- 15 QBR for one activity
- 16 Peer Review Participation

Enter ?? for more options, ??? for brief descriptions, ?OPTION for help text.

Select DBA Option: **11** Integration Agreements Menu

Select Integration Agreements Menu Option: ?

- 0 Instructions for Entering IA's
- 1 Get New Integration #'s
- 2 Add/Edit
- 3 Inquire
- 4 Roll-up into Mail Message
- 5 File Agreements Menu ...
- 6 Routine Agreements Menu ...
- 7 Subscriber Package Menu ...
- 8 Custodial Package Menu ...
- 9 Print Other
- 10 Print Pending
- 11 Print Active
- 12 Print All
- 13 List Supported References
- 14 List Open Subscription
- 15 List Controlled Subscription
- 16 Subscribe to an Open Subscription Reference

Enter ?? for more options, ??? for brief descriptions, ?OPTION for help text.

External Relations

Select Integration Agreements Menu Option: **8** Custodial Package Menu

Select Custodial Package Menu Option: **?**

- 1 Print ACTIVE by Custodial Package
- 2 Print ALL by Custodial Package

Enter ?? for more options, ??? for brief descriptions, ?OPTION for help text.

Select Custodial Package Menu Option: **1** Print ACTIVE by Custodial Package

Select PACKAGE NAME: LAB

- 1 LAB SERVICE LR
- 2 LAB SITE CODE LBAR

CHOOSE 1-2: 1

DEVICE: **(Enter Printer Name)**

****LAB SERVICE Custodial DBI Agreements ****

NAME: DBIA240-A	ENTRY: 240
CUSTODIAL PACKAGE: LAB SERVICE	Dallas
SUBSCRIBING PACKAGE: AUTOMATED MED INFO	Albany
USAGE: Private	APPROVED: APPROVED
STATUS: Active	EXPIRES:
DURATION: Till Otherwise Agr	VERSION:
FILE: 63	ROOT: LR(
DESCRIPTION:	TYPE: File

Laboratory Package has given permission to AMIE to make the following calls:

GLOBAL REF.	NODE;PIECE	USAGE
^LR("CH";11	Current Agreement number 95
	"MI";11	Current Agreement number 95
^LR(D0, 'CH',		
^LR(D0, 'MI',		

ROUTINE:

This listing continues for many pages and will not be reproduced here.

Laboratory as a Subscriber

The Laboratory is also a subscriber to other packages for permission to use their entry points or information.

LAB SERVICE Integration Agreements subscribed to

```
-----
NAME: File 101                      ENTRY: 872

CUSTODIAL PACKAGE: ORDER ENTRY/RESULT      Salt Lake City
SUBSCRIBING PACKAGE: LAB SERVICE           Dallas
  USAGE: Controlled Subscri APPROVED: APPROVED
  STATUS: Active                          EXPIRES:
  DURATION: Till Otherwise Agr VERSION:
  FILE: 101                               ROOT: ORD(101,
DESCRIPTION:                               TYPE: File
This file may be referenced by packages to maintain protocols within their
namespace. This file may also be pointed to.
ROUTINE:
```

```
NAME: File 100.99                    ENTRY: 874

CUSTODIAL PACKAGE: ORDER ENTRY/RESULT      Salt Lake City
SUBSCRIBING PACKAGE: LAB SERVICE           Dallas
  USAGE: Controlled Subscri APPROVED: APPROVED
  STATUS: Active                          EXPIRES:
  DURATION: Till Otherwise Agr VERSION:
  FILE: 100.99                           ROOT: ORD(100.99,
DESCRIPTION:                               TYPE: File
This file may be referenced by packages interfacing with OE/RR to see if
OE/RR has been installed in the manner:
I $D(^ORD(100.99)) ...
```

Packages may also setup entries in the Package Parameters portion of this file.
ROUTINE:

```
NAME: DBIA916                        ENTRY: 916
CUSTODIAL PACKAGE: VA FILEMAN          San Francisco
SUBSCRIBING PACKAGE: LAB SERVICE       Dallas
  For duration of Lab Version 5.2: Blood Bank and
  Anatomic Pathology namespaced routines refer to
  ^DIC(file #,0,"GL") to locate global nodes for data.
  USAGE: Controlled Subscri APPROVED: APPROVED
  STATUS: Active                        EXPIRES:
  DURATION: Next Version                VERSION: Fileman 20
  FILE:                                ROOT: DIC(
DESCRIPTION:                            TYPE: File
^DIC(D0,0,'GL')
1      GLOBAL NAME                      Direct Global Read
                                           A direct global read is
                                           performed on this node to
                                           determine the global root for a file.
```

External Relations

ROUTINE:

NAME: File 100.98 ENTRY: 873
CUSTODIAL PACKAGE: ORDER ENTRY/RESULT Salt Lake City
SUBSCRIBING PACKAGE: LAB SERVICE Dallas
USAGE: Controlled Subscri APPROVED: APPROVED
STATUS: Pending EXPIRES:
DURATION: Till Otherwise Agr VERSION:
FILE: 100.98 ROOT: ORD(100.98,
DESCRIPTION: TYPE: File

This file may be referenced to determine an appropriate Display Group for an order in the manner:

S ORTO=\$O(^ORD(100.98,'B','OTHER HOSPITAL SERVICES',0))

ROUTINE:

NAME: File 100.01 ENTRY: 875
CUSTODIAL PACKAGE: ORDER ENTRY/RESULT Salt Lake City
SUBSCRIBING PACKAGE: LAB SERVICE Dallas
USAGE: Controlled Subscri APPROVED: APPROVED
STATUS: Pending EXPIRES:
DURATION: Till Otherwise Agr VERSION:
FILE: 100.01 ROOT: ORD(100.01,
DESCRIPTION: TYPE: File

This file may be pointed to.

ROUTINE:

NAME: PSJEEU ENTRY: 901
CUSTODIAL PACKAGE: INPATIENT MEDICATI Birmingham
SUBSCRIBING PACKAGE: LAB SERVICE Dallas
USAGE: Controlled Subscri APPROVED: APPROVED
STATUS: Active EXPIRES:
DURATION: Till Otherwise Agr VERSION:
FILE: ROOT:
DESCRIPTION: TYPE: Routine

This is a set of utilities that can be used to create, validate and process order timing schedules.

ROUTINE: PSJEEU

COMPONENT: ENSE

VARIABLES: PSJPP Input

This is the package prefix as found in the PACKAGE file (9.4).

PSJSHLS Input

This is executable code that sets \$T to be used to screen Hospital Locations when editing schedules and shifts. If PSJSHLS exists, DIC("S") is set to PSJSHLS. The scheduler will not try to validate PSJSHLS.

Allows the editing of the ADMINISTRATION SCHEDULE file (51.1)

COMPONENT: ENSHE

VARIABLES: PSJPP Input

This is the package prefix as found in

			the PACKAGE file (9.4).
	PSJSHLS	Input	This is executable code that sets \$T to be used to screen Hospital Locations when editing schedules and shifts. If PSJSHLS exists, DIC("S") is set to PSJSHLS. The scheduler will not try to validate PSJSHLS.
			Allows the editing of the ADMINISTRATION SHIFT file (51.15).
COMPONENT:	ENSVI		
VARIABLES:	PSJPP	Input	This is the package prefix as found in the PACKAGE file (9.4).
	PSJX	Input	This is the schedule to be viewed. If only the first few characters of the schedule name is entered, the user will be asked to select from all schedules in the ADMINISTRATION SCHEDULE file (51.1) beginning with these characters. If a valid schedule is selected, information pertaining to the schedule will be displayed.
			View standard schedule information.
COMPONENT:	ENSV		
VARIABLES:	PSJX	Both	This is the schedule to be validated. If only the first few characters of the schedule name is entered, the user will be asked to select from all schedules in the ADMINISTRATION SCHEDULE file (51.1) beginning with these characters. If a valid schedule is selected, it's name will will be returned in PSJX. If a valid schedule is not selected, PSJX will be killed.
	PSJPP	Input	This is the package prefix as found in the PACKAGE file (9.4).
	PSJM	Output	This is the frequency in minutes that the action is to be taken. This will be null if PSGX is invalid.
	PSJAT	Output	These are the administration times or shifts that are associated with the selected schedule. This will be null if PSGX is invalid.
	PSJY	Output	This is a pointer to the ADMINISTRATION SCHEDULE file (51.1) if PSJX is found in the file. This will be null if PSJX is invalid or not found.
	PSJTS	Output	This is a code representing the type of schedule. This will be null if the schedule is invalid.
	PSJAX	Output	

External Relations

			This is the maximum days continuous orders last for the selected schedule, or null if not found.
	PSJW	Input	This is a pointer to the HOSPITAL LOCATION file (44). This is an optional variable that may be used to determine the administration times or shifts by location.
	PSJNE	Input	If this optional variable is defined, there is no dialogue with the user. Validates a schedule and gives the administration times or shifts and frequency (in minutes) of the schedule.
COMPONENT:	ENATV		
VARIABLES:	X	Both	This contains the administration times to be validated. X will be killed if the administration times are invalid. Validates administration times. This may be used in an input transform.
COMPONENT:	ENSHV		
VARIABLES:	X	Both	This should be set to the administration shift to be validated. If the administration shift passed in X is invalid, X will be killed. Validates shifts. If the shift passed in X is invalid X will be killed.
COMPONENT:	ENSPU		
VARIABLES:	PSJSCH	Input	This is the schedule to be processed.
	PSJM	Input	This is the frequency (in minutes) that an action is to take place. Used for continuous and range schedules.
	PSJAT	Input	This is either a set of administration times or shifts, depending on the type of schedule. If it is administration times, it will be similar to: PSJAT="04-08-12-16-20". If it is shifts, it will be similar to: PSJAT="M-E", PSJAT("M")="05-11", PSJAT("E")="18-22".
	PSJTS	Input	This is a code representing the type of schedule defined in PSJSCH. The codes are: C - CONTINUE; D - DAY OF THE WEEK; DR - DAY OF THE WEEK-RANGE; O - ONE-TIME; R - RANGE; and S - SHIFT.
	PSJSD	Input	This is the start date/time of the order.
	PSJFD	Input	This is the stop date/time of the period where the action is to take place.
	PSJOSD	Input	This is the start date/time of the order.

External Relations

```

NAME: ORUHDR                      ENTRY: 862
CUSTODIAL PACKAGE: ORDER ENTRY/RESULT      Salt Lake City
SUBSCRIBING PACKAGE: LAB SERVICE           Dallas
  USAGE: Controlled Subscri APPROVED:
  STATUS: Pending                        EXPIRES:
  DURATION: Till Otherwise Agr  VERSION:
  FILE:                                  ROOT:
DESCRIPTION:                            TYPE: Routine
  ROUTINE: ORUHDR
COMPONENT:  EXT
VARIABLES:  ORIFN      Both
                                Internal number in file 100 of the order
                                to display.
ORAGE      Output
                                Patient age.
ORIO      Output
ORANSI    Output
ORDOB     Output
                                Patient Date of Birth
ORFT      Output
ORHI      Output
ORNP      Output
                                Pointer to file 200 for Current
                                Agent/Provider
ORL        Output
                                Variable pointer to the variable pointer.
ORPD      Output
ORPNM     Output
                                Patient name
ORPV      Output
                                Pointer to Provider file for the person
                                requesting the order.
ORSEQ     Output
ORSEX     Output
                                Patient sex.
ORSSN     Output
                                Patient SSN
ORTIT     Output
                                Title
ORTS      Output
                                Pointer to Treating Specialty associated
                                with the order.
ORVP      Output
                                Variable pointer toe object of an order.
ORWARD    Output
                                Inpatient Ward location
                                Displays a standard header for detailed order displays.  If
                                calling this from within OE/RR, it is not necessary to
                                killthe returned variables.  OE/RR will kill them.
COMPONENT:  PGBRK
VARIABLES:  DIROUT     Output
                                User entered a '^'
OREND      Output
                                User entered a '^'
                                Displays 'Press return to continue or "^" to escape' at
                                page breaks.
*****

```

```

NAME: ORUPREF2                ENTRY: 863
CUSTODIAL PACKAGE: ORDER ENTRY/RESULT      Salt Lake City
SUBSCRIBING PACKAGE: LAB SERVICE           Dallas
  USAGE: Controlled Subscri APPROVED:
  STATUS: Pending                       EXPIRES:
  DURATION: Till Otherwise Agr  VERSION:
  FILE:                                ROOT:
  DESCRIPTION:                          TYPE: Routine
  ROUTINE: ORUPREF2
  COMPONENT: EN3
  VARIABLES: ORPKG      Input
                                Package pointer.
  ORDEF      Input
                                Default protocol for setting up protocols.
  ORFL      Input
                                File link - variable pointer for procedure
                                file.
  ORDANM    Input
                                Optional name of the protocol.
  ORDA      Input
                                Internal number of an existing protocol
                                to be updated.
  OREA      Input
                                Action used in lieu of default defined in
  OROEF
  ORTXT      Input
                                Name of protocol; if not defined, the .01
                                filed of the procedure referenced is used.
Utility for 'on-the-fly' protocol creation. See OE/RR
Developers guide.

```

```

NAME: ORUTL                    ENTRY: 864
CUSTODIAL PACKAGE: ORDER ENTRY/RESULT      Salt Lake City
SUBSCRIBING PACKAGE: LAB SERVICE           Dallas
  USAGE: Controlled Subscri APPROVED:
  STATUS: Pending                       EXPIRES:
  DURATION: Till Otherwise Agr  VERSION:
  FILE:                                ROOT:
  DESCRIPTION:                          TYPE: Routine
  ROUTINE: ORUTL
  COMPONENT: READ
  VARIABLES:

```

```

NAME: ORVOM                    ENTRY: 865
CUSTODIAL PACKAGE: ORDER ENTRY/RESULT      Salt Lake City
SUBSCRIBING PACKAGE: LAB SERVICE           Dallas
  USAGE: Controlled Subscri APPROVED:
  STATUS: Pending                       EXPIRES:
  DURATION: Till Otherwise Agr  VERSION:
  FILE:                                ROOT:
  DESCRIPTION:                          TYPE: Routine
  ROUTINE: ORVOM

```

External Relations

```
NAME: ORX                               ENTRY: 866
CUSTODIAL PACKAGE: ORDER ENTRY/RESULT   Salt Lake City
SUBSCRIBING PACKAGE: LAB SERVICE         Dallas
  USAGE: Controlled Subscri APPROVED: APPROVED
  STATUS: Pending                       EXPIRES:
  DURATION: Till Otherwise Agr VERSION:
  FILE:                                 ROOT:
DESCRIPTION:                             TYPE: Routine
ROUTINE: ORX
COMPONENT: FILE
VARIABLES: OREPDUZ      Input
                                DUZ of the person entering the order.
                                ORL      Input
                                Variable pointer to the variable pointer.
                                ORPCL    Input
                                Variable pointer to the protocol that
                                created the order.
                                ORNP      Input
                                Pointer to file 200 for Current
                                Agent/Provider
                                ORVP      Input
                                Variable pointer to the object of an
                                order.
                                ORCOST    Input
                                Cost of the order
                                OREVENT   Input
                                Two piece variable delimited by a
                                semicolon. The first piece is the time
                                at which an event should occur. The
                                second piece is a character that has
                                meaning to a package.
                                ORIT      Input
                                Variable pointer to the item ordered.
                                ORLOG     Input
                                Time the order is entered.
                                ORPK      Input
                                Package reference defined by the package
                                when an order is created.
                                ORPURG    Input
                                Grace days before an order is purged.
                                ORSTOP    Input
                                Order Stop Date
                                ORSTRT   Input
                                Order start date
                                ORSTS     Input
                                Order status
                                ORTO      Input
                                Pointer to Display Group file. Identifies
                                the service receiving the order.
                                ORTS      Input
                                Pointer to Treating Specialty associated
                                with the order.
                                ORTX(i)   Input
                                Order Text.
                                ORIFN     Output
                                Internal entry number of order in file
                                100
COMPONENT: RETURN
```



```

NAME: ORX7                      ENTRY: 870
CUSTODIAL PACKAGE: ORDER ENTRY/RESULT      Salt Lake City
SUBSCRIBING PACKAGE: LAB SERVICE           Dallas
  USAGE: Controlled Subscri APPROVED:
  STATUS: Pending                         EXPIRES:
  DURATION: Till Otherwise Agr VERSION:
  FILE:                                    ROOT:
  DESCRIPTION:                             TYPE: Routine
ROUTINE: ORX7
COMPONENT: DC
VARIABLES: ORIFN      Input
                                Pointer to the order.
ORNATR      Input
                                Identifies the Nature of Order.
This entry point is provided for orders that are discontinued
by the service. This creates a DC order for the order
identified by ORIFN.
*****

```

```

NAME: ORX8                      ENTRY: 871
CUSTODIAL PACKAGE: ORDER ENTRY/RESULT      Salt Lake City
SUBSCRIBING PACKAGE: LAB SERVICE           Dallas
  USAGE: Controlled Subscri APPROVED: APPROVED
  STATUS: Pending                         EXPIRES:
  DURATION: Till Otherwise Agr VERSION:
  FILE:                                    ROOT:
  DESCRIPTION:                             TYPE: Routine
ROUTINE: ORX8
COMPONENT: EN(ORIFN)
VARIABLES: ORIFN      Input
                                Pointer to the order.
ORUPCHUK(' Output
                                =WHO ENTERED^External Format
ORUPCHUK(' Output
                                =PATIENT LOCATION
ORUPCHUK(' Output
                                =CURRENT AGENT/PROVIDER^External format
ORUPCHUK(' Output
                                =WHEN ENTERED
ORUPCHUK(' Output
                                =PROTOCOL
ORUPCHUK(' Output
                                =CURRENT AGENT/PROVIDER^External Format
ORUPCHUK(' Output
                                =STOP DATE
ORUPCHUK(' Output
                                =CURRENT START DATE
ORUPCHUK(' Output
                                =STATUS^External format
ORUPCHUK(' Output
                                =TO (display group)^External Format
ORUPCHUK(' Output
                                =ORDER TEXT (Multiple)
ORUPCHUK(' Output
                                =OBJECT OF ORDER
This entry point returns data from the Order file (100) for
a particular order.

```

External Relations

COMPONENT: NOTIF(ORIFN,ORNOTE)
VARIABLES: ORIFN Input
ORNOTE Input
Pointer to the order
Pointer to the notification

NAME: DBIA13 ENTRY: 13
CUSTODIAL PACKAGE: REGISTRATION Albany
SUBSCRIBING PACKAGE: LAB SERVICE Salt Lake City
USAGE: Private APPROVED: APPROVED
STATUS: Active EXPIRES:
DURATION: Till Otherwise Agr VERSION:
FILE: 2 ROOT: DPT(
DESCRIPTION: TYPE: File
PATIENT NODE .35 - DEATH INFO USED TO STUFF ^LR(GLOBAL.
^DPT(dfn,.35)
.351 DATE OF DEATH .35;1 Direct Global Write
.352 DEATH ENTERED BY .35;2 Direct Global Write
ROUTINE:

NAME: DBIA29 ENTRY: 29
CUSTODIAL PACKAGE: VA FILEMAN San Francisco
SUBSCRIBING PACKAGE: LAB SERVICE Salt Lake City
USAGE: Private APPROVED: APPROVED
STATUS: Active EXPIRES:
DURATION: Till Otherwise Agr VERSION:
FILE: ROOT: DD(
DESCRIPTION: TYPE: File
Routines LRWU5 & LRWU7 Do direct sets to the Data Dictionary. The routines allow the user to add a new Data Name or Antibiotic without giving programmer access.
ROUTINE:

NAME: DBIA327 ENTRY: 327
CUSTODIAL PACKAGE: VA FILEMAN San Francisco
SUBSCRIBING PACKAGE: LAB SERVICE Dallas
USAGE: Private APPROVED: APPROVED
STATUS: Active EXPIRES:
DURATION: Till Otherwise Agr VERSION:
FILE: .401 ROOT: DIBT(
DESCRIPTION: TYPE: File
Laboratory V5.2 (only V5.2) is granted the following exemption:

The laboratory is supplying a pre release 5.2 patch. The patch will allow the site to mimic the conversion process required for V5.2 install. As a part of the process a FileMan sort template is created of all providers the software was unable to repoint to VA(200.

The creation of the sort template is done with a DIC call and a DR string. We are not aware of a method to load the actual data. Therefore, this function is hard coded.

The exemption is only required for the one time conversion process. Listed below is the actual code involved. Please advise of any suggestion you feel will be of benefit.

```
EXCEPT(LRFILE,LRD0)      ;- LOGS EXCEPTIONS FROM THE CONVERSIONS OF DATA
FROM 6 A ND 16
    ; exceptions are put into a SORT template so the the site can
    ; then use fileman enter edit to correct problems found.
    ;
    N DIC,LRSORT,X,Y
    I '$D(^DIBT("B",LRFILE_ "-EXCEPTIONS")) D ADD
    I '$D(LRSORT) S LRSORT=$O(^DIBT("B",LRFILE_ "-EXCEPTIONS",0))
    S ^DIBT(LRSORT,1,LRD0)=" "
    Q
    ;
ADD      ; add a new sort template to be used for exception logging and
editing
    N X,Y
    S DIC="^DIBT(",DIC(0)="L",DIC("DR")="2///^S X="T";4///^S X=$P(LR
FILE," "-",2);5///^S X=0;"
    S X=LRFILE_ "-EXCEPTIONS" D FILE^DICN S LRSORT=+Y
    Q
```

ROUTINE:

```

NAME: DBIA98-B                      ENTRY: 561
CUSTODIAL PACKAGE: TASK-MANAGER QUEUE      San Francisco
SUBSCRIBING PACKAGE: LAB SERVICE           Salt Lake City
USAGE: Private                          APPROVED: APPROVED
STATUS: Active                          EXPIRES:
DURATION: Till Otherwise Agr  VERSION:
FILE:                                    ROOT: %ZTSK(
DESCRIPTION:                             TYPE: File
Version 5.1 of the laboratory package has a temporary agreement for the
following:
2) To reference the global %ZTSK directly to display the error trap data.
(Rick has been notified of our usage of the %ZTSK global)

```

When Kernel release their error trapping system, Lab will convert to the Kernel supported methodology.

ROUTINE:

```

NAME: DBIA912                      ENTRY: 912
CUSTODIAL PACKAGE: VA FILEMAN        San Francisco
SUBSCRIBING PACKAGE: LAB SERVICE     Dallas
USAGE: Private                      APPROVED: APPROVED
STATUS: Active                      EXPIRES:
DURATION: Next Version              VERSION: Fileman 20
FILE:                               ROOT: DIC(
DESCRIPTION:                         TYPE: File
^DIC("AC" - Screen lookup on files for the Lab application group.
^DIC("AC","LR"
ROUTINE:

```

External Relations

```
NAME: DBIA913 ENTRY: 913
CUSTODIAL PACKAGE: REGISTRATION Albany
SUBSCRIBING PACKAGE: LAB SERVICE Dallas
USAGE: Private APPROVED: APPROVED
STATUS: Active EXPIRES:
DURATION: Till Otherwise Agr VERSION:
FILE: 21 ROOT: DIC(21
DESCRIPTION: TYPE: File
In Lab V 5.2 patient Persian Gulf information is being obtained from
inquiries to global locations. Routines LRAPPOW and LRAPDPT reference the
globals ^DIC(21, .
^DIC(21,
.01 NAME 0;1 Direct Global Read
ROUTINE:
```

```
NAME: DBIA917 ENTRY: 917
CUSTODIAL PACKAGE: VA FILEMAN San Francisco
SUBSCRIBING PACKAGE: LAB SERVICE Dallas
USAGE: Private APPROVED: APPROVED
STATUS: Active EXPIRES:
DURATION: Till Otherwise Agr VERSION:
FILE: ROOT: DISV(
DESCRIPTION: TYPE: File
Laboratory V 5.2 uses ^DISV(DUZ,"LRACC") and ^DISV(DUZ,"LRAN") to store
items.
An example is in routine LRACC at line LRACC+4:
S:$L(X)>2 ^DISV(DUZ,"LRACC")=X S:X=" " X=$S($D(^DISV(DUZ,"LRACC"))):
^("LRACC"),1:"?")
Lab needs an agreement for read/write access to ^DISV(DUZ,"LRACC") and
^DISV(DUZ,"LRAN")
ROUTINE:
```

```
NAME: DBIA918 ENTRY: 918
CUSTODIAL PACKAGE: REGISTRATION Albany
SUBSCRIBING PACKAGE: LAB SERVICE Dallas
USAGE: Private APPROVED: APPROVED
STATUS: Active EXPIRES:
DURATION: Till Otherwise Agr VERSION:
FILE: 2 ROOT: DPT(
DESCRIPTION: TYPE: File
Read only access for the ^DPT( global to obtain Period of Service and POW
information.
Read ^DPT(dfn,.52) to obtain POW information.
Read ^DPT(dfn,.32) to obtain Period of Service information.
^DPT(dfn,.52)
.525 POW STATUS INDICATED .52;5 Direct Global Read
.526 POW CONFINEMENT LOCA .52;6 Direct Global Read
^DPT(dfn,.32)
.323 PERIOD OF SERVICE .32;3 Direct Global Read
ROUTINE:
```

```

NAME: DBIA921                      ENTRY: 921
CUSTODIAL PACKAGE: PHARMACY          Birmingham
SUBSCRIBING PACKAGE: LAB SERVICE     Dallas
  USAGE: Private                     APPROVED: APPROVED
  STATUS: Active                      EXPIRES:
  DURATION: Till Otherwise Agr        VERSION:
  FILE: 52.6                          ROOT: PS(52.6,
DESCRIPTION:                          TYPE: File
Read only access for the ^PS(52.6,X,0) node.
In routines LRBLPE1 and LRBLPH:

```

```

...I $D(^PS(52.6,X,0)...W !,"IV DRUG: ", $P(^(), "^")
^PS(52.6,x,0)
.01      PRINT NAME          0;1      Direct Global Read
ROUTINE:
*****

```

```

NAME: DBIA923                      ENTRY: 923
CUSTODIAL PACKAGE: SCHEDULING        Albany
SUBSCRIBING PACKAGE: LAB SERVICE     Dallas
  USAGE: Private                     APPROVED: APPROVED
  STATUS: Active                      EXPIRES:
  DURATION: Till Otherwise Agr        VERSION:
  FILE: 40.7                          ROOT: DIC(40.7
DESCRIPTION:                          TYPE: File

```

The following fields are accessed in a read-only manner:

```

^DIC(      40.7      STOP CODE file
          1      AMIS REPORTING STOP CODE

```

```

In routines LRCAPPH line LRCAPPH+8
SDC      S SDC=$S($P(^("NITE"),U,3):$G(^DIC(40.7,+ $P(^LAB(69.9,1,"NITE")),
          U,3),0)),1:"") S LRSDC=$S($P(SDC,U,2):+$P(SDC,U,2),1:108)
LRSTOPC line LRSTOPC+3
S
LRSDC=$S(+ $P($G(^DIC(40.7,+ $P($G(^LAB(69.9,1,"NITE")),U,3),0)),U,2):
$P(^(),U,2),1:108),CNT=0,LREND=0

```

Routine LRSTOPC manually records clinic stop codes for Lab. Routine LRCAPPH automatically records clinic stop codes for Lab.

```

ROUTINE:
*****

```

```

NAME: DBIA924                      ENTRY: 924
CUSTODIAL PACKAGE: REGISTRATION      Albany
SUBSCRIBING PACKAGE: LAB SERVICE     Dallas
  USAGE: Private                     APPROVED: APPROVED
  STATUS: Active                      EXPIRES:
  DURATION: Till Otherwise Agr        VERSION:
  FILE: 11                            ROOT: DIC(11,
DESCRIPTION:                          TYPE: File

```

Read only access for the ^DIC(11, global.
 In routine LRMIHDR line LRMIHDR+22:

```

I LRMARST S LRMARST=$S($D(^DIC(11,LRMARST,0)): $P(^(),U),1:"")
^DIC(11,D0,0)
.01      NAME          0;1      Direct Global Read
ROUTINE:
*****

```

External Relations

NAME: DBIA925 ENTRY: 925
CUSTODIAL PACKAGE: REGISTRATION Albany
SUBSCRIBING PACKAGE: LAB SERVICE Dallas
USAGE: Private APPROVED: APPROVED
STATUS: Active EXPIRES:
DURATION: Till Otherwise Agr VERSION:
FILE: 10 ROOT: DIC(10,
DESCRIPTION: TYPE: File
Read only access to the ^DIC(10, global.
In routine LRMIHDR line LRMIHDR+21:
I LRRACE S LRRACE=\$S(\$D(^DIC(10,LRRACE,0)):\$P(^0),U),1:"")
^DIC(10,D0,0)
.01 NAME 0;1 Direct Global Read
ROUTINE:

NAME: DBIA931 ENTRY: 931
CUSTODIAL PACKAGE: REGISTRATION Albany
SUBSCRIBING PACKAGE: LAB SERVICE Dallas
USAGE: Private APPROVED: APPROVED
STATUS: Active EXPIRES:
DURATION: Till Otherwise Agr VERSION:
FILE: 81 ROOT: ICPT(
DESCRIPTION: TYPE: File
Direct read access to the ^ICPT(global, CPT file #81.
In routine LRBLPCSS, Blood Bank Pre-op Component selection,
read node ^ICPT(x,"D",z,0) to print description field.
In routine LRBLPOST, Blood Bank Post-init, read node ^ICPT(x,"LR"). This
will move all 66 fields to our own field in ^LAB(66.5, . This is one time
for V. 5.2 installation only.
^ICPT(x,'D',z,0)
.01 DESCRIPTION 0;1 Direct Global Read
^ICPT(x,'LR',y,0)
66 BLOOD COMPONENT REQU 0;1 Direct Global Read
ROUTINE:

NAME: DBIA935 ENTRY: 935
CUSTODIAL PACKAGE: REGISTRATION Albany
SUBSCRIBING PACKAGE: LAB SERVICE Dallas
USAGE: Private APPROVED: APPROVED
STATUS: Active EXPIRES:
DURATION: Till Otherwise Agr VERSION:
FILE: 22 ROOT: DIC(22,
DESCRIPTION: TYPE: File
In Lab V 5.2 patient POW information is being obtained from inquiries to
global locations. Routines LRAPPOW and LRAPDPT reference the global
^DIC(22, .
^DIC(22
.01 NAME 0;1 Direct Global Read
ROUTINE:

```

NAME: DBIA908                      ENTRY: 908
CUSTODIAL PACKAGE: SCHEDULING      Albany
SUBSCRIBING PACKAGE: LAB SERVICE   Dallas
  USAGE: Private                   APPROVED:
  STATUS: Pending                   EXPIRES:
  DURATION: Till Otherwise Agr     VERSION:
  FILE: 44                          ROOT: SC(
DESCRIPTION:                        TYPE: File

```

Read only access for the ^SC global.
 Read ^SC(n,0) to obtain Hospital Location name and abbreviation.
 TREATING SPECIALTY used as pointer to 45.7 FACILITY TREATING SPECIALTY, ^DIC(45.7,TREATING SPECIALTY,0), which is used as pointer to file 42.4, SPECIALTY, ^DIC(42.4,FACILITY TREATING SPECIALTY,0)
 Read ^SC("B", and ^SC("C", cross references to get patient location internal entry #: \$O(^SC("B",X,0)) and \$O(^SC("C",X,0)).
 Read access to the ^SC(D0,"I") node to obtain inactivate date (field # 2505) and re-activate date (field # 2506).
 Read only access to ^SC(D0,"S",D1,1,D2,0) to access patients by clinic location and clinic date to print lab report.
 Read only access to ^SC(D0,"S",DATE) used to check if a clinic meets on a specified date.

```

^SC(D0,0)
.01      NAME                0;1      Direct Global Read
1        ABBREVIATION        0;2      Direct Global Read
3        INSTITUTION         0;4      Direct Global Read
9.5     TREATING SPECIALTY   0;20    Direct Global Read
2        TYPE                 0;3      Direct Global Read
^SC(D0,'I')
2505    INACTIVATE DATE      I;1     Direct Global Read
2506    REACTIVATE DATE      I;2     Direct Global Read
^SC('B',
.01      NAME                Direct Global Read
                          B Cross Reference
^SC('C',
1        ABBREVIATION        Direct Global Read
                          C Cross Reference
^SC(D0,'S',D1,1,D2,0)
ROUTINE:

```

```

NAME: DBIA920                      ENTRY: 920
CUSTODIAL PACKAGE: PHARMACY        Birmingham
SUBSCRIBING PACKAGE: LAB SERVICE   Dallas
  USAGE: Private                   APPROVED:
  STATUS: Pending                   EXPIRES:
  DURATION: Till Otherwise Agr     VERSION:
  FILE: 52                          ROOT: PSRX(
DESCRIPTION:                        TYPE: File

```

Read only access for the ^PSRX(x,0) node.
 In routines LRBLPE1 and LRBLPH:
 ...I \$D(^PSRX(Y,0)) S ^TMP(\$J,+SP(^(), "^",6))=O
 ^PSRX(x,0)
 6 DRUG 0;6 Direct Global Read
 ROUTINE:

External Relations

```

NAME: DBIA922                      ENTRY: 922
CUSTODIAL PACKAGE: PHARMACY          Birmingham
SUBSCRIBING PACKAGE: LAB SERVICE     Dallas
  USAGE: Private                     APPROVED:
  STATUS: Pending                     EXPIRES:
  DURATION: Till Otherwise Agr       VERSION:
  FILE: 55                            ROOT: PS(55
DESCRIPTION:                          TYPE: File
Read only access to the following nodes in the Pharmacy Patient file #55.
All these references are found in routines LRBLPE1 and LRBLPH.
^PS(55,DFN,"IV",X,"AD",Y,0)
K ^TMP($J) F X=0:0 S X=$O(^PS(55,DFN,"IV",X)) Q:'X!(R[U) F Y=0:0
  S Y=$O(^PS(55,DFN,"IV",X,"AD",Y)) Q:'Y!(R[U) S ^TMP($J,+^(Y,0))=" "
^PS(55,DFN,5,X,1,Y,0)
K ^TMP($J) F X=0:0 S X=$O(^PS(55,DFN,5,X)) Q:'X!(R[U) F Y=0:0
  S Y=$O(^PS(55,DFN,X,1,Y)) Q:'Y!(R[U) S ^TMP($J,+^(Y,0))=" "
^PS(55,dfn,'IV',x,'AD',y,0)
.01      ADDITIVE                    0;1      Direct Global Read
^PS(55,dfn,5,x,1,y,0)
.01      DRUG                        0;1      Direct Global Read
ROUTINE:

```

```

NAME: DBIA927                      ENTRY: 927
CUSTODIAL PACKAGE: SURGERY          Birmingham
SUBSCRIBING PACKAGE: LAB SERVICE     Dallas
  USAGE: Private                     APPROVED:
  STATUS: Pending                     EXPIRES:
  DURATION: Till Otherwise Agr       VERSION:
  FILE: 130                          ROOT: SRF(
DESCRIPTION:                          TYPE: File
Read only access for the ^SRF global.
Routine LRBLPCSS, blood bank routine, pre-op component selection,
checks for pending operations by looping through the "ADT" Date of
Operation cross reference then lists operations scheduled. The date,
operation procedure, and principal procedure code is listed.
^SRF('ADT',dfn,x,a)
.09      DATE OF OPERATION            0;9      Direct Global Read
                                                Loop through this
                                                cross-reference to list
                                                operations scheduled.
^SRF(DO,'OP')
  Direct Read Access to print operation procedure and code.
ROUTINE:

```

```

NAME: DBIA995                      ENTRY: 995
CUSTODIAL PACKAGE: OUTPATIENT PHARMAC Birmingham
SUBSCRIBING PACKAGE: LAB SERVICE     Dallas
  USAGE: Private                     APPROVED:
  STATUS: Pending                     EXPIRES:
  DURATION: Till Otherwise Agr       VERSION:
  FILE: 55                            ROOT: PS(55,
DESCRIPTION:                          TYPE: File
Read only access to the following nodes in the Pharmacy Patient file #55.
This reference is found in routines LRBLPE1 and LRBLPH.

```

```

^PS(55,DFN,"P",X,0)
F X=0:0 S X=$O(^PS(55,DFN,"P",X)) Q:'X I $D(^X,0) S Y=+^(0)
  I $D(^PSRX(Y,0))...
^PS(55,DFN,'P',X,0)
.01      PRESCRIPTION PROFILE 0;1      Direct Global Read
ROUTINE:

```

```

NAME: DBIA999      ENTRY: 999
CUSTODIAL PACKAGE: VA FILEMAN      San Francisco
SUBSCRIBING PACKAGE: LAB SERVICE      Dallas
  USAGE: Private      APPROVED:
  STATUS: Pending      EXPIRES:
  DURATION: Till Otherwise Agr  VERSION:
  FILE:      ROOT: DD(
DESCRIPTION:      TYPE: File
Read only access for the ^DD( Global.

```

ROUTINE:

```

NAME: DBIA98-A      ENTRY: 98
CUSTODIAL PACKAGE: TASK-MANAGER QUEUE      San Francisco
SUBSCRIBING PACKAGE: LAB SERVICE      Salt Lake City
  USAGE: Private      APPROVED: APPROVED
  STATUS: Active      EXPIRES:
  DURATION: Till Otherwise Agr  VERSION:
  FILE:      ROOT:
DESCRIPTION:      TYPE: Other

```

Version 5.1 of the laboratory package has a temporary agreement for the following:

1) To save system \$Z variables in local variables for storage in our error trap.

When Kernel release their error trapping system, Lab will convert to the Kernel supported methodology.

ROUTINE:

```

NAME: DBIA893      ENTRY: 893
CUSTODIAL PACKAGE: SURGERY      Birmingham
SUBSCRIBING PACKAGE: LAB SERVICE      Dallas
  USAGE: Private      APPROVED: APPROVED
  STATUS: Active      EXPIRES:
  DURATION: Next Version  VERSION:
  FILE:      ROOT:
DESCRIPTION:      TYPE: Other

```

The LRSPOLR* routines were written by Alan Monosky (surgery developer) to provide an interface with the Surgery software. These routines have been changed to SROSPLG* and will reside in the Surgery namespace. An integration agreement is requested so as to export these routines with Version 5.2 of the Lab Package. Changes were made to Lab Routine LRAPLG which references LRSPOLR.

ROUTINE: SROSPLG*

External Relations

NAME: DBIA910 ENTRY: 910
CUSTODIAL PACKAGE: MAILMAN Washington
SUBSCRIBING PACKAGE: LAB SERVICE Dallas
USAGE: Private APPROVED:
STATUS: Pending EXPIRES:
DURATION: Till Otherwise Agr VERSION:
FILE: ROOT:
DESCRIPTION: TYPE: Other
Lab is requesting a new domain for the purpose of uploading a monthly laboratory workload reports to Austin. The increase in traffic should be less than 30K per institution once per month. Typically a message is about 200 lines.
NAME: Q-LMI.VA.GOV FLAGS: S
RELAY DOMAIN: FOC-AUSTIN.VA.GOV DHCP ROUTING INDICATOR:LAB
PHYSICAL LINK DEVICE: MINIOUT TRANSMISSION SCRIPT: SCRIPT TEXT:
ROUTINE:

NAME: DBIA911 ENTRY: 911
CUSTODIAL PACKAGE: KERNEL San Francisco
SUBSCRIBING PACKAGE: LAB SERVICE Dallas
USAGE: Private APPROVED:
STATUS: Pending EXPIRES:
DURATION: Till Otherwise Agr VERSION:
FILE: ROOT:
DESCRIPTION: TYPE: Other
Lab requests a sharing agreement to export the Diagram Menus (XUUSERACC) option within the LAB LIAISON (LRLIAISON) menu.
ROUTINE:

NAME: DBIA83 ENTRY: 83
CUSTODIAL PACKAGE: SCHEDULING Albany
SUBSCRIBING PACKAGE: LAB SERVICE Salt Lake City
USAGE: Private APPROVED: APPROVED
STATUS: Active EXPIRES:
DURATION: Till Otherwise Agr VERSION:
FILE: ROOT:
DESCRIPTION: TYPE: Routine
Lab uses supported call EN3^SDACS for adding stop codes.
ROUTINE: SDACS
COMPONENT: EN3
VARIABLES:

INTERNAL RELATIONS

Internal Relations

The Menu Entry Action, D ^LRPARAM, must be on any menu entry to Laboratory options (it only needs to be at the highest menu). Likewise, the Menu Exit Action D ^LRKILL must be on the same highest menus.

Stand Alone Menus

The following menus have menu actions necessary for their proper functioning. Items on these menus must not be moved without incorporating the appropriate actions.

LA INTERFACE	Lab interface menu	Menu Entry Action: D ^LAJOB1
LRMENU	Laboratory	Menu Entry Action: D ^LRPARAM Menu Exit Action: D ^LRKILL
LRMI	Microbiology menu	Menu Exit Action: K A,Z
LRUAC	Print accession list(s)	None
LRBL	Blood Bank Menu	Menu Entry Action: S IOP ="HOME" D ^%ZIS W @IOF,?35, "BLOOD BANK"
LR INTEGRITY	Lab Routine Integrity Menu	None

The global reference, ^LAC(\$J, is used for temporary storage of data while reprinting a permanent page from the cumulative.

The global references ^LA(and ^LAH(is used for Auto Instrument and workload functions (non FileMan compatible).

All of the routines, files, and options within the Laboratory V. 5.2 software package are within SACC programming requirements.

PACKAGE-WIDE VARIABLES

Package-Wide Variables

Package-Wide Variables

Laboratory V. 5.2 package wide variables are created by the routine LRPARAM. A call to this routine should be placed on the highest Laboratory User Menu in the entry field. Laboratory local variables are deleted by the routine LRKILL. A call to this routine should be placed as a exit action on the highest Laboratory User Menu.

LRBLOOD	Default specimen type for blood
LRLABKY	Variable to indicate if the user has certain security keys Variable is defined if the user holds LRLAB key 1st piece by ^ is 1 if user holds LRVERIFY 2nd piece by ^ is 1 if user holds LRSUPERVISOR 3rd piece by ^ is 1 if user holds LRLAISON
LRORN	Set to 1 if OE/RR is activated
LRPARAM	Set to 1 concatenated with 2-255 pieces of the ^LRO(69.9,1,0) globals contains information from the LABORATORY SITE file
LRPARAM(VR)	The version number of Laboratory Package installed
LRPLASMA	Default plasma specimen type
LRSERUM	Default serum specimen type
LRUNKNOW	Default unknown specimen type
LRURINE	Default urine specimen type
LRVIDO	Escape sequence required to turn no reverse video and video blink
LRVIDOF	Escape sequence required to turn of LRVIDO action

SACC EXEMPTIONS LIST

4 STANDARD SECTION: 4B Package-wide variables
DATE GRANTED:
LRBLOOD, LRDT0, LRORN, LRPARAM, LRPLASMA, LRUNKNOW, LRSERUM,
and LRURINE are package-wide variables for use within LAB.

Package-Wide Variables

STANDARDS AND CONVENTIONS COMMITTEE (SACC) EXEMPTIONS

Standards and Conventions Committee (SACC) Exemptions

SACC EXEMPTIONS LIST

JUL 28,1994 15:33 PAGE 1

LAB SERVICE

- 1 STANDARD SECTION: 6D FM compatibility
DATE GRANTED:
The LA global is exempted from VA FileMan compatibility. It holds raw data from automated instruments.

- 2 STANDARD SECTION: 6D FM compatibility
DATE GRANTED:
The LAH global is exempted from VA FileMan compatibility. It holds the raw data while it is being processed.

- 3 STANDARD SECTION: 2A OPEN, CLOSE device
DATE GRANTED:
Laboratory, when dealing with automated instruments, may issue direct OPENS and CLOSEs of devices.

- 4 STANDARD SECTION: 4B Package-wide variables
DATE GRANTED:
LRBLOOD, LRDT0, LRORN, LRPARAM, LRPLASMA, LRUNKNOW, LRSERUM, and LRURINE are package-wide variables for use within LAB.

- 5 STANDARD SECTION: 5C Vendor specific routines
DATE GRANTED:
The Laboratory package has a temporary exemption to use a vendor specific routine, %ET, to capture errors during background data processing. It is only used during interfaced instrument data processing. When Kernel provides the needed functionality Laboratory will discontinue use of %ET.

- 6 STANDARD SECTION: 2D2 * & # READS
DATE GRANTED: JUL 17,1989
The Laboratory package may use * and #-reads in the software for the auto-instrument interface and keyboard emulators.

- 7 STANDARD SECTION: 6F KILL DD global
DATE GRANTED: MAR 20,1990
A one time exemption has been granted for direct Sets and Kills of specific DD's in the version 5 post init routine.

SACC Exemptions and Globals

- 8 STANDARD SECTION: 1 ANSI
DATE GRANTED: MAR 4,1991
Laboratory may use the argumentless FOR in version 5.1.
- 9 STANDARD SECTION: 2A B,J,V,Z,\$V,\$Z
DATE GRANTED: MAR 18,1991
Lab may save system \$Z variables in local variables for storage in their error trap for automated instruments.
- 10 STANDARD SECTION: 5F %ZTLOAD
DATE GRANTED: MAR 18,1991
Lab may reference the global %ZTSK directly to display the error trap data stored there.
- 11 STANDARD SECTION: 6F KILL DD global
DATE GRANTED: MAR 18,1991
Lab may kill bad "NM" and bad 9.2 DD nodes directly in their 5.1 post init.

ON-LINE DOCUMENTATION

On-Line Documentation

This section describes how to generate on-line documentation. It also provides file numbers and/or file number ranges, namespaces, and special templates. The user is informed where to find Kernel documentation, how to print the data dictionaries, and diagram menus.

File Number Ranges

The Laboratory files number ranges includes Files #60 through #69.91 and #95.

Namespacing

Laboratory uses the name spaces of LR and LA for all exported routines, menus, options, and templates.

Special Templates

Two compiled print templates included in the Laboratory V. 5.2 package are located in BLOOD DONOR file (#65.5).

Templates	Routines Invoked
LRBL DONOR TESTING REPORT	^LRBLDPT
LRBL DONOR TESTING SUPPLEMENT	^LRBLDPK

On-Line Help Using Kernel

On-line documentation about the Laboratory may be obtained in a number of ways. The print OPTION file (#19) and Menu Management Menu will display a list of namespaced options associated with the Laboratory package. Other namespaced entries may also be retrieved from the Print, Input, and Sort Templates files, and the Security Key, Function, Bulletin, and Help Frame files. The structure of the file may be displayed with the VA FileMan List File Attributes options in several formats. Routines may be printed with options on the Programmer's Option Menu which call the %ZPT1 routine to print the first and optionally second line, or %ZTPP to print the entire routine to an output device. Globals may be displayed with the List Globals option.

The use of question marks at the file and field level is described in the VA FileMan Technical Manual. The use of question marks within the menu system will invoke help about options and menus. See On-line Help From Your Terminal Screen section for further information.

On-line Help From Your Terminal Screen

All DHCP applications provide some degree of on-line help for users. This means that assistance is available to you from the computer, on your terminal screen. In the menu system, the help function will assist you with your menus, describing your options so that you make the proper choice.

? Displays menu

If you enter a single question mark, you will be given a list of the menu options available to you. Only the options which pertain to the specific application you are working in will be listed.

?? More Options

Two question marks will give you your menu options plus a list of automatic menu options. These are options you do not normally see on your menus, but which are available to you in any program you are working in. This menu is referred to as your secondary menu. Locked options are displayed if the user holds the key.

??? Describes Options

Three question marks provide you with a brief description of the options you can choose from. Use this feature when you are uncertain which menu option to select in order to accomplish your work.

? (option name)

If you type one question mark and the option name (or the first letter or number), you will enter the on-line help frame system (if your site has installed the help frames, check with your site manager). Information is available about the series of prompts and technical data for that option or menu, etc.

How To Print Data Dictionaries

The structure of the file may be displayed with the VA FileMan List File Attributes options in several formats.

Example: How to print a Data Dictionary using VA FileMan.

```
Select VA FileMan Option:  8  List File Attributes

OUTPUT FROM WHAT FILE:  //  60 LABORATORY TEST

Select SUB-FILE:  <RET>
Select LISTING FORMAT:  STANDARD//  <RET>
DEVICE:  (Enter Printer Name)  RIGHT MARGIN:  132//  <RET>
```

GLOBAL JOURNALING

Global Journaling

NAME	GLOBAL	JOURNALLING	DESCRIPTION
LAB SERVICE			
	LAB	optional--not required	This global contains the basic laboratory files used in setting up the package.
	LR	mandatory!	<p>This global contains the patients results which have been verified by the laboratory package. It also contains status of test. e.g., "Pending" Other data such as cummulative or archive data is also stored in this global.</p> <p>**** Protection of this global is very important.</p> <p>Order and accessions point to entries in this file.</p>
	LAR		This file contains the archive patient data. It indicates where the data has been stored and certain other information.
	LRD	mandatory!	This file contains information relative to the Blood Bank Donor Inventory. This file is very important to Blood Bank.
	LRE	optional--not required	This file contains certain donor information which the Blood Bank module has collected over time. If data is lost it could impact the Blood Bank if it runs a donor program.

Global Journaling

LRT	optional--not required	This file contains results on specimens which are not patients e.g., Research, Enviromental, Referral, and Sterilizer In some cases Patient Data could be stored in this global, if so, then this global should be treated as ^LR(global.
LRO	mandatory!	This file generally contains the Order made to the Laboratory Package. Without this file all previous orders can not be referenced. Care should be made to preserve this file.
DIC(68.4		This globals contains work list heading and is the only Laboratory global not name spaced.
LAM	mandatory!	This file contains the nationally distributed WKLD Code file. It also may contain those site specific entries.

Lab Automated Instruments

LAB(62.4,	not recommended	FILE OF AUTOMATED INSTRUMENTS PARAMETERS
LA(not recommended	This global contains strings of data going to and coming from auto mated instruments. It also contains the index into auto instrument generated errors trap. For certain instruments there will be "C" nodes These are used for storage when using bi-directional instrument.
LAH(not recommended	This global contains automated instrument data awaiting verification the Technologist.

MAPPING ROUTINES

Mapping Routines

Mapping Routines

The following routines should be mapped.

LGEN	LAMIAUT0	LAMIAUT1	LAMIAUT2	LAMIAUT3	LAMIAUT4	LAMIAUT5
LAMIAUT6	LAMIAUT7	LAMIAUT8				
LRAFUNC	LRAFUNC1	LRAFUNC5	LRAFUNC6	LRAFUNC7	LRCAPA12	
LRCAPU	LRCAPV	LRCAPV1	LRCAPV11	LRCAPV1A	LRCAPV2	LRCAPV3
LRDIQ	LRDPA	LRDPA1	LRDPA2	LRGEN	LRGEN1	LRGEN2
LRLABAR	LRLABLD	LRLABLD0	LRLABLIO	LRLTR	LRLTR2	
LRMIBUG	LRMIEDZ	LRMIEDZ2	LRMIEDZ3	LRMIEDZ4	LRMIPSU	LRMIPSZ
LRMIPSZ1	LRMIPSZ2	LRMIPSZ3	LRMIPSZ4	LRMIPSZ5	LRMIV1	LRMIV2
LRMIV3	LRMIV4	LRMIVER	LRMIVER1	LRORD	LRORD1	LRORD2
LRORD2A	LRORD3	LRORDD	LRORDST	LRORDST1	LROW	LROW1
LROW1A	LROW2	LROW2A	LROW2P	LROW2RP	LROW3	LROW4
LROW5	LRPARAM	LRRP	LRRP1	LRRP2	LRRP3	LRRP4
LRRP5	LRRP5A	LRRP6	LRRP6A1	LRRP6A2	LRRP6A3	LRRP6B1
LRRP6B2	LRRP6B3	LRRP8	LRRP8A	LRRP8B	LRVER	LRVER1
LRVER2	LRVER3	LRVER3A	LRVER4	LRVER5	LRVR	LRVR1
LRVR2	LRVR3	LRVR4	LRVR5	LRWU	LRWU1	LRWU2
LRWU3	LRWU4	LRWU5	LRWU6	LRX	LRXREF	LRXREF1

GLOSSARY

Glossary

This Glossary contains terms and their definitions that may not be familiar to the user who is accessing the facility's computers for the first time. Basic terms, acronyms, and phrases that are used throughout the DHCP environment are included.

Abbreviated Response	This feature allows you to enter data by typing only the first few characters for the desired response. This feature will not work unless the information is already stored in the computer.
Access Code	A code that allows the computer to identify you as a user authorized to gain access to the computer. Your code is greater than six and less than twenty characters long; can be numeric, alphabetic, or a combination of both; and is usually assigned by a site manager or application coordinator. (See the term verify code in the Glossary.)
Accession	A unique alpha numeric (combination of letters and numbers) assigned to an individual patient specimen when it is received in the laboratory. The accession is assigned by the computer and contains the laboratory departmental designation, the date and an accession number. This accession serves as identification of the specimen as it is processed through the laboratory. (Example: HE 0912)
Accession Area	A functional area or department in the laboratory where specific tests are performed. The accession area defines the departmental designation contained in each accession.
Accession Date	The date of the accession, part of the total alpha-numeric accession of each specimen.
Accession Number	A unique number assigned to each accession.
ADP	Automated Data Processing
ADT	Admission, Discharge, Transfer. A component of the MAS software package .

Glossary

AFIP	Armed Forces Institute of Pathology; an external review board.
AEMS	Automated Engineering Management Systems. This is the Engineering Service software package.
AMIE	Automated Management Information Exchange. A system that allows the Veterans Benefits Administration to use their WANG System to query medical centers via the VADATS network.
AMIS	Automated Management Information System: a method for tabulating Workload.
AMIS/CAP Codes	Numbers assigned to lab procedures by the College of American Pathology for compiling work statistics.
ANSI	American National Standards Institute. An organization that compiles and publishes computer industry standards.
ANSI MUMPS	The MUMPS programming language is a standard; that is, an American National Standard. MUMPS stands for Massachusetts General Hospital Utility Multi Programming System.
APP	Applications Portability Profile
Algorithm	A predetermined set of instructions for solving a specific problem in a limited number of steps.
Application	A computer program (e.g., a package) that accomplishes tasks for a user.
Application Coordinator	The designated individual responsible for user level management and maintenance of an application package (e.g., IFCAP, Laboratory, Pharmacy, Mental Health).
ARG	Applications Requirements Group
Array	An arrangement of elements in one or more dimensions. A MUMPS array is a set of nodes referenced by subscripts which share the same variable name.

ASCII	American Standard Code for Information Interchange. A series of 128 characters, including uppercase and lowercase alpha characters, numbers, punctuation, special symbols, and control characters.
Attribute Dictionary	See data dictionary.
Audit	An audit is a physical record of access to a file. The VA FileMan and Kernel provide audit tools that may be used to maintain a continuous audit trail of changes that are made to an existing database. Elements that can be tracked include, but are not limited to, fields within files and files themselves. Records are kept of the date/time and user making changes. In addition, the Kernel provides tools for auditing system access, option access, and device usage. Logs store the date/time of access, user identification and name of the option or device used.
Audit Access	A user's authorization to mark or indicate that certain information stored in a computer file should be audited.
Audit Trail	A chronological record of computer activity automatically maintained to trace the use of the computer.
Auto Instruments	Automated instruments used in the Lab that identify and measure tissue or other specimens.
Backup	The process of creating duplicate data files and/or program copies as are serve in case the original is lost or damaged.
Baud (Baud rate)	A measure of times per second that switching can occur in a communications channel. Data transmission speed roughly equivalent to 1 bit per second (bps). Commonly used baud rates include 300, 1200, 2400, 3600, 4800, 9600.
Bidirectional	Automated instruments that send and receive information from DHCP.

Glossary

Boolean	A term used in computer science for data that is binary (i.e., either true or false).
Boot	To load instructions into main memory to get a computer operational.
Buffer	A temporary holding area for information.
Bug	An error in a program. Bugs may be caused by syntax errors, logic errors, or a combination of both.
CAP	College of American Pathology
Caret	A symbol expressed as “^” (up caret), “<” (left caret), or “>” (right caret). The “^” (up caret) is also known as the (up-arrow symbol) or (shift-6) key. In many MUMPS systems, a “>” (right caret) is used as a system prompt and a “^” (up caret) as an exiting tool from an option.
Checksum	The result of a mathematical computation involving the individual characters of a routine or file.
Cipher	A system that arbitrarily represents each character by one or more other characters.
Collection List	A listing of routine laboratory tests ordered for inpatients. The list is used by the Phlebotomy team during routine collection of specimens from the wards. The list is sorted by ward location, and includes both patient information (Name, SSN, bed/room number) and test information, type of specimen to collect, amount needed, date and time tests were ordered, urgency status, order number and accession number.
Command	A combination of characters that instruct the computer to perform a specific operation.

Computed Field	This field takes data from other fields and performs a predetermined mathematical function (e.g., adding two columns together). You will not, however, see the results of the mathematical calculation in the file. Only when you are printing or displaying information on the screen will you see the results for this type of field.
Computer	A device that processes information. A machine that has input, output, storage, and arithmetic devices plus logic and control units.
Control Key	The Control Key (Ctrl on the keyboard) performs a specific function in conjunction with another key. In some word processing applications, for example, holding down the Ctrl key and typing an A will cause a new set of margins and tab settings to occur; Ctrl-S causes printing on the terminal screen to stop; Ctrl-Q restarts printing on the terminal screen; Ctrl-U deletes an entire line of data entry when the return key is pressed.
Core	The fundamental clinical application packages of DHCP. The original core of applications built on the Kernel and VA FileMan were Admission, Discharge and Transfer (ADT), Scheduling, Outpatient Pharmacy, and Clinical Laboratory. Additional software packages were added to implement Core+6 and Core+8 configurations.
CPU	Central Processing Unit. Those parts of computer hardware that carry out arithmetic and logic operations, control the sequence of operations performed, and contain the stored program of instructions.

Cross Reference	A cross reference on a file provides direct access to the entries in several ways. For example, the Patient file is cross referenced by name, social security number, and bed number. When asked for a patient, the user may then respond with either the patient's name, social security number, or bed number. Cross reference speeds up access to the file for printing reports. A cross reference is also referred to as an index or cross index.
CRT	Cathode Ray Tube. A piece of computer hardware that looks something like a television screen. The CRT and keyboard collectively are called your terminal. A vacuum tube that guides electrons onto a screen to display characters or graphics. Also called VDT for video display terminal.
Cumulative	A chartable patient report of all data accumulated on a patient over a given time period.
Cursor	A flashing image on your screen (generally a horizontal line or rectangle) that alerts you that the computer is waiting for you to make a response to an instruction (prompt).
Data	In the generic sense, data is information that can be processed and/or produced by computers.
Data Attribute	A characteristic of a unit of data such as length, value, or method of representation. VA FileMan field definitions specify data attributes.
Database	A set of data, consisting of at least one file. that is sufficient for a given purpose. The Kernel database is composed of a number of VA FileMan files. A collection of data about a specific subject (e.g., the Patient file). A data collection has different data fields (e.g., patient name, SSN, date of birth). An organize collection of data about a particular topic.

Database Management System	A collection of software that handles the storage, retrieval and updating of records in a database. A Database Management System (DBMS) controls redundancy of records and provides the security, integrity, and data independence of a database.
Data Dictionary	A Data Dictionary (DD) contains the definitions of a file's elements (fields or data attributes); relationships to other files; and structure or design. Users generally review the definitions of a file's elements or data attributes; programmers review the definitions of a file's internal structure.
Data Dictionary Access	A user's authorization to write/update/edit the data definition for access computer file. Also known as DD Access.
Data Dictionary Listing	This is the printable report that shows the data dictionary. DDs are used by users, programmers, and Documenters.
Data Processing	Logical and arithmetic operations performed on data. These operations maybe performed manually, mechanically, or electronically. Sorting through a card file by hand would be an example of the first method; using a machine to obtain cards from a file would be an example of the second method; and using a computer to access a record in a file would be an example of the third method.
DBA	Within the VA, the Database Administrator oversees package development with respect to DHCP Standards and Conventions (SAC) such as namespacing, file number ranges, and integration issues.
Debug	To correct logic errors and/or syntax errors in a computer program. To remove errors from a program.

Default	A response the computer considers the most probable answer to the prompt being given. It is identified by double slash marks (/) immediately following it. This allows you the option of accepting the default answer or entering your own answer. To accept the default, you simply press the enter (or return) key. To change the default answer, type in your response.
Delete	The key on your keyboard (may also be called D or backspace on some terminals) which allows you to delete individual characters working backwards by placing the cursor immediately after the last character of the string of characters you wish to delete. The "@" sign (shift 2) may also be used to delete a file entry or data attribute value. The computer will ask "Are you sure you want to delete this entry?" to insure you do not delete an entry by mistake.
Delimiter	A special character used to separate a field, record, or string. VA FileMan uses the " character as the delimiter within strings.
Device	A terminal, printer, modem, or other type of hardware or equipment associated with a computer. A host file of an underlying operating system may be treated like a device in that it may be written to (e.g., for spooling).
DHCP	The Decentralized Hospital Computer Program of the Veterans Health Administration (VHA), Department of Veterans Affairs (VA). DHCP software, developed by the VA, is used to support clinical and administrative functions at VA medical centers nationwide. It is written in MUMPS and, via the Kernel, will run on all major MUMPS implementations regardless of vendor. DHCP is composed of packages which conform with name spacing and other DHCP standards and conventions.
Disk	The medium used in a disk drive for storing data.

Disk Drive	A peripheral device that can be used to read and write on a hard or floppy disk.
Documentation	User documentation is an instruction manual that provides users with sufficient information to operate a system. System documentation describes hardware and operating systems provided by a system vendor. Program documentation describes a program's organization and the way in which the program operates and is intended as an aid to programmers who will be responsible for revising the original program.
DRG	Diagnostic Related Group
DSCC	The Documentation Standards and Conventions Committee
DSS	Decision Support System
E3R	Electronic Error Enhancement Reporting System
Electronic Signature	A code that is entered by a user which represents his or her legally binding signature.
Encryption	Scrambling data or messages with a cipher or code so that they are unreadable without a secret key. In some cases encryption algorithms are one directional; they only encode and the resulting data cannot be unscrambled (e.g., access/verify codes).
Enter	Pressing the return or enter key tells the computer to execute your instruction or command or to store the information you just entered.
Entry	A VA FileMan record. It is uniquely identified by an internal entry number (the .001 field) in a file.
Extended Core	Those applications developed after the basic core DHCP packages were installed (e.g., Dietetics, Inpatient Pharmacy). Also referred to as Core+6 or Core+8.

Glossary

EP	Expert Panel
Field	In a record, a specified area used for the value of a data attribute. The data specifications of each VA FileMan field are documented in the file's data dictionary. A field is similar to blanks on forms. It is preceded by words that tell you what information goes in that particular field. The blank, marked by the cursor on your terminal screen, is where you enter the information.
File	A set of related records treated as a unit. VA FileMan files maintain a count of the number of entries or records.
FileManager	See VA FileMan.
FOIA	The Freedom Of Information Act. Under the provisions of this public law, software developed within the VA is made available to other institutions, or the general public, at a nominal charge that covers the cost of reproduction, materials, and shipping.
Free Text	The use of any combination of numbers, letters, and symbols when entering data.
FTAM	File Transfer, Access, and Management
GKS	Graphic Kernel Standard
Global	In the MUMPS language, a global is a tree structured data file stored in the common database on the disk.
Global Variable	A variable that is stored on disk (MUMPS usage).
GOSIP	Government Open Systems Interconnection Profile
Hacker	A computer enthusiast; also, one who seeks to gain unauthorized access to computer systems.

Hardware	The physical equipment pieces that make up the computer system (e.g., terminals, disk drives, central processing units). The physical components of a computer system.
Header	Information at the top of a report.
Help Prompt	The brief help that is available at the field level when entering one or more question marks.
HINQ	Hospital Inquiry. A system that permits medical centers to query the Veterans Benefits Administration systems via the VADATS network.
HIS	Hospital Information Systems
IFCAP	Integrated Funds Distribution, Control Point Activity, Accounting, and Procurement
IHS	Indian Health Service
IHS	Integrated Hospital System
Interactive Language	The dialogue that takes place between the computer and the user in the form of words on the screen of the user's CRT.
Initialization	The process of setting variables in a program to their starting value.
Input Transform	An executable string of MUMPS code which is used to check the validity of input and converts it into an internal form for storage.
IRAC	Information Resources Advisory Council
IRM	Information Resource Management
ISC	Information Systems Center
JCAHO	Joint Commission for the Accreditation of Health Care Organizations.

Jump (also called Up Arrow Jump)

The “^” (shift 6 on most keyboards) allows you to jump or up arrow jump to and from a particular field within an input template to another field within that same input template. You may also Jump from one menu option to another menu option without having to respond to all the prompts in between. To jump, type an “^” (shift 6), and then type the name of the field in the template or option on your menu you wish to jump to.

Kernel

A set of DHCP software routines that function as an intermediary between the host operating system and the DHCP application packages such as Laboratory, Pharmacy, IFCAP, etc. The Kernel provides a standard and consistent user and programmer interface between application packages and the underlying MUMPS implementation. Two Kernel components, VA FileMan and MailMan, are self contained to the extent that they may stand alone as verified packages. Some of the Kernel components are listed below along with their associated namespace assignments.

VA FileMan DI
MailMan XM
Sign-on Security XU
Menu Management XQ
Tools XT
Device Handling ZIS
Task Management ZTM

Key

A security code that is assigned to individual users that allows access to options.

Lab Data

Patient’s verified laboratory data.

Lab Sub-section

Refers to the subdivision of lab major sections. If your lab uses this system, your reports will be printed and totaled by lab sub-section as well as lab section.

LAYGO access

A user’s authorization to create a new entry when editing a computer file. (Learn As You GO, the ability to create new entries).

Line Editor	This is VA FileMan s special line-oriented text editor. This editor is used for the word-processing data type.
Local Variable	A variable that is stored in a local partition.
Load List	Used for organizing the workload in various accession areas of the laboratory. A load list is generated for each automated instrument, and is used to arrange the order in which standards, controls and patient specimens are to be run on the specific instrument.
Log In/On	The process of gaining access to a computer system.
Log Out/Off	The process of exiting from a computer system.
Looping	A set of instructions in a program that are repeatedly executed. When set up correctly, VA FileMan allows you to loop through groups of entries in a file without having to select each entry individually.
LSI	Laboratory System Interface, an instrument for translating data between DHCP and auto instruments.
Magnetic Tape	Plastic or mylar tape on reels or cassettes used for data storage (also called mag tape).
MailMan	An electronic mail system that allows you to send and receive messages from other users via the computer.
Major section	Refers to the grouping of lab subsections into major groups within the lab. A lab may consist of the following major sections: General Clinical (may include hematology, toxicology, serology, chemistry, etc.), Blood Bank and Anatomic Pathology. If your lab uses this system, your workload report will be reported by major section ("Section Workload Report").
Mandatory Field	This is a field that requires a value. A null response is not valid.

Glossary

MAS	Medical Administration Service
Menu	A list of options you are authorized access to and may select from.
Menu Tree	A series of menus you sequence through in order to get to the specific option you desire.
Microscan	An automated instrument used for organism identification and for measuring antibiotics within the Microbiology module.
MIRMO	Medical Information Resources Management Office in the Department of Veterans Affairs Central Office in Washington, DC.
MIS	Management Information Systems
Modem	<p>A device for connecting a terminal to a telephone line, allowing it to communicate with another modem. Modems include the following types.</p> <p>Direct Connect: The modem is directly hooked into the phone line.</p> <p>Acoustic: The modem is connected to the telephone through the handset.</p> <p>Auto Answer: When it detects a ring signal, the modem will “answer the phone.”</p> <p>Auto Dial—The modem, upon command from the terminal or the computer, will dial another modem.</p>
Multiple-valued	More than one data value is allowed as the value of a data attribute for an entry.
MUMPS	Massachusetts General Hospital Utility Multi-Programming System
Name spacing	A convention for naming DHCP package elements. The DBA assigns unique character strings for package developers to use in naming routines, options, and other package elements so that packages may coexist. The DBA also assigns a separate range of file numbers to each package.

NAVAP	National Association of VA Physicians
NCD	National Center for Documentation, located at the Birmingham ISC.
NIST	National Institute of Standards and Technology
NOAVA	Nationwide Office Automation for Veterans Affairs
Node	In a tree structure, a point at which subordinate items of data originate. A MUMPS array element is characterized by a name and a unique subscript. Thus the terms node, array element, and subscripted variable are synonymous. In a global array, each node might have specific fields or "pieces" reserved for data attributes such as name. In data communications, the point at which one or more functional units connect transmission lines.
Numeric field	A response that is limited to a restricted number of digits. It can be dollar valued or a decimal figure of specified precision.
OE/RR	Order Entry and Results Reporting
On-line	A device is on-line when it is connected to the computer.
On the fly	A term given to the process of not permanently storing data in the data dictionary but having a computation performed at run time.
Operating System	A basic program that runs on the computer, controls the peripherals, allocates computing time to each user, and communicates with terminals.

Glossary

Order number	A number generated daily by the computer each time a test is ordered - unique for each patient order - starting at midnight with order number 1. The order number provides identification of patient specimens both during transport to the laboratory and until accession numbers have been assigned to the specimens. Generally used by non laboratory personnel; e.g., ward, section, number.
OS/M	Occurrence Screen/Monitor
Output Transform	An executable string of MUMPS code which converts internally stored data into a readable display.
PACS	Picture Archiving and Communications Systems
Package	The set of programs files, documentation, help prompts, and installation procedures required for a given software application. For example, Laboratory, Pharmacy, and MAS are packages. A DHCP software environment composed of elements specified via the Kernel's Package file. Elements include files and associated templates, name spaced routines, and name spaced file entries from the Option, Key, Help Frame, Bulletin, and Function files. Packages are transported using VA FileMan's DIFROM routine that creates initialization routines to bundle the files and records for export. Installing a package involves running the installation routines that will recreate the original software environment. Verified packages include documentation. As public domain software, verified packages may be requested through the Freedom of Information Act (FOIA).
Password	A user's secret sequence of keyboard characters, which must be entered at the beginning of each computer session to provide the user's identity.

Pattern Match	A preset formula that includes any one of the following types: letters, numbers, or symbols; 2) letters, numbers, and symbols; 3) letters and numbers; 4) symbols and letters; 5) numbers and symbols. If the information entered does not match the formula exactly, the computer rejects the user's response.
Peripheral Device	Any hardware device other than the computer itself (central processing unit plus internal memory). Typical examples include card readers, printers, CRT units, and disk drives.
Pointer	Points to another file where the computer stores information needed for the field of the file in which you are currently working. If you change any of the information in the field in which you are working, the new information is automatically entered into the "pointed to" file.
POSIX	Portable Operating System Interface for Computing Environments
Printer	A printing or hard copy terminal.
Program	A list of instructions written in a programming language and used for computer operations.
Programmer Access Code	An optional three-to-eight character code that allows the computer to identify you as a user authorized to enter into programmer mode (see also access code). Once in programmer mode you will use Standard MUMPS DHCP official programming language to interact with the computer. Programmer access is very tightly restricted to authorized and qualified individuals.
Programmer Access	Privilege to become a programmer on the system and work outside many of the security controls of Kernel.
Prompt	The computer interacts with the user by issuing questions called prompts, to which the user issues a response.

Glossary

QA	Quality Assurance
RAM	Random Access Memory
Read Access	A user's authorization to read information stored in a computer file.
Record	A set of related data treated as a unit. An entry in a VA FileMan file constitutes a record. A collection of data items that refer to a specific entity. For example, in a name-address-phone number file, each record would contain a collection of data relating to one person.
Required Field	A mandatory field, one that must not be left blank. The prompt for such a field will be asked until the user enters a valid response.
RMEC	Regional Medical Education Center
ROM	Read Only Memory. A type of memory that can be read but not written.
Routine	A program or a sequence of instructions called by a program, that may have some general or frequent use. MUMPS routines are groups of program lines which are saved, loaded, and called as a single unit via a specific name .
SAC	Standards and Conventions. Through a process of verification, DHCP packages are reviewed with respect to SAC guidelines as set forth by the Standards and Conventions Committee (SACC). Package documentation is similarly reviewed in terms of standards set by the Documentation Standards and Conventions Committee (DSCC).
SACC	Standards and Conventions Committee of the Decentralized Hospital Computer Program.
Screen	(Noun) The display surface of a video terminal.

Screen	(Verb) The process of checking a user's input for a predefined format or condition (e.g., date within a permitted range).
Screen Editor	This is VA FileMan's special screen oriented text editor. This editor is used for the word-processing data type.
Scroll/no scroll	The scroll/no scroll button (also called hold screen) allows the user to stop (no scroll) the terminal screen when large amounts of data are displayed too fast to read and restart (scroll).
SERA	Systematic External Review of Autopsies.
SERS	Systematic External Review of Surgical Pathology.
Set of codes	Usually a preset code with one or two characters. The computer may require capital letters as a response (e.g., M for male and F for female). If anything other than the acceptable code is entered, the computer will reject the response.
Site Manager/IRM Chief	At each site, the individual who is responsible for managing computer systems, installing and maintaining new modules, and serving as liaison to the ISCs.
SIUG/ARG	Special Interest User Group/Application Requirements Group. A designated group of applications experts who work with the developers of a software package to define and approve the contents of the package.
SNOMED	Systematized Nomenclature of Medicine, developed to standardize the coding of information regarding specific diseases.
Software	The set of instructions and data required to operate the computer. One type is called operating system software - fundamental computer software that supports other software. The second type is called applications software - customized programs that tell the computer how to run applications (e.g., Pharmacy, Laboratory)

Glossary

Spacebar Return Feature	You can answer a VA FileMan prompt by pressing the spacebar and then the return key. This indicates to VA FileMan that you would like the last response you were working on at that prompt recalled.
Spooling	Procedure by which programs and output can be temporarily stored until their turn to print.
SQL	Structured Query Language
Stop Code	A number assigned to the various clinical, diagnostic, and therapeutic sections of a facility
Sub-routine	A sequence of MUMPS code that performs a specific task, usually used more than once.
Subscript	A symbol that is associated with the name of a set to identify a particular subset or element. In MUMPS, a numeric or string value that is enclosed in parentheses; is appended to the name of a local or global variable; identifies a specific node within an array.
Syntax	A term for the rules that govern the construction of a machine language.
Template	A means of storing report formats, data entry formats, and sorted entry sequences is the opposite of "On the Fly". A template is a permanent place to store selected fields for use at a later time.
Terminal	See CRT. May be either a printer or CRT/monitor/visual display terminal.
Treating Area	The section or service of the hospital that requests a test. Some hospital systems have an embedded code that determines if the ordered test is for an inpatient or outpatient.

Tree Structure	A term sometimes used to describe the structure of a MUMPS array. This has the same structure as a family tree, with the root at the top, and ancestor nodes arranged below, according to their depth of subscripting. All nodes with one subscript are at the first level, all nodes with two subscripts at the second level, and so on.
Trigger	A trigger is an instruction that initiates a procedure. In VA FileMan, a trigger can be set up when entry of data in one field automatically updates a second field value.
Truncate	Truncating is a process that drops characters of text or numbers (without rounding) when the text or numbers are limited to a specific location to store or print them. For example, the number 5.768 is truncated to 5.76 when stored or printed in a location that holds only four characters.
Uneditable Field	This is a status given to fields to prevent any editing of data in the field.
Up Arrow	A character on your keyboard that looks like this “^”. The “^” character is used mainly for exiting or opting out of answering VA FileMan prompts and jumping to other fields in VA FileMan. The “^” character is the “shift 6” key on most keyboards.
User Access	Access to a computer system. The user’s access level determines the degree of computer use and the types of computer programs available. The systems manager assigns the user an access level. (See also access code and programmer access code.)
Utility Routine	A routine that performs a task that many programmers utilize.
VA	The Department of Veterans Affairs, formerly called the Veterans Administration.
VACO	Department of Veterans Affairs Central Office

VADATS	Veterans Administration Data Transmission System
VA FileMan	A set of programs used to enter, maintain, access, and manipulate a database management system consisting of files. A package of online VA FileManager computer routines written in the MUMPS language which can be used as a stand alone database system or as a set of application utilities. In either form, such routines can be used to define, enter, edit, and retrieve information from a set of computer-stored files.
VA MailMan	A computer-based message system.
VAMC	Department of Veterans Affairs Medical Center
Variable	A character or group of characters that refer to a value. MUMPS recognizes three types of variables: local variables, global variables, and special variables. Local variables exist in a partition of main memory and disappear at sign off. A global variable is stored on disk, potentially available to any user. Global variables usually exist as parts of global arrays. The term "global" may refer either to a global variable or a global array. A special variable is defined by system operation (e.g., \$TEST).
VAX	Virtual Address Extension
VDT	Video Display Terminal (See CRT)
Verification (data verification)	The process by which technologists review the data the computer for a specific patient and verify (validate) that it is accurate before releasing the data to the physician.
Verification (package verification)	A process of internal and external package review carried out by a DHCP verification team (people who were not involved in the development of the package). Software and associated documentation are reviewed in terms of DHCP Standards and Conventions.

Verify Code	An additional security precaution used in conjunction with the access code. Like the access code, it is also 6 to 20 characters in length and if entered incorrectly will not allow the user to access the computer. To protect the user, both codes are invisible on the terminal screen.
VHA	Veterans Health Administration.
VITEK	An automated instrument is used for organism identification and for measuring antibiotics within the Microbiology module.
WKLD	This is the abbreviation for workload used by the Laboratory package.
Work List	Used for collecting and organizing work in various accession areas of the laboratory. A work list is generated for manual or automated tests (singly or in batches) and can be defined by number of tests and/or which tests to include. It can also be used as a manual worksheet by writing test results directly on the worklist.
Wrap-around mode	Text that is fit into available column positions and automatically wraps to the next line, sometimes by splitting at word boundaries (spaces).
Write Access	A user's authorization to write/update/edit information stored in a computer file.

APPENDIX A

Appendix A

EXCERPTS FROM GENERAL DIGITAL'S MAINTENANCE AND OPERATIONS MANUAL FOR THE GDC 2100 (LSI)

Section 1 Data Concentrator

1.1 General Description

The GDC-2100 is a general purpose computer programmed to perform a data concentration function. The computer is composed of a DEC SBC 11/21 PLUS single-board computer and two DEC DLV11-J's. The modules are housed and powered by a Sigma SA-H136 chassis. Data input and output is accomplished via 10 RJ11 connectors on the back panel.

Some features of the GDC 2100 are:

- DEC PDP 11 instruction set
- 32 K bytes of RAM
- 16 K bytes of ROM
- 60 HZ clock
- 10 RS232 serial ports interfaced through RJ11 connectors
- 65 watt power supply
- cooling fan
- external power and restart connectors

1.2 Application Description

The GDC 2100 has 10 serial connectors. The connectors are numbered P1, P2, 1J0-1J3, and 2J0-2J3. The software accepts data from all connectors except P1 in blocks up to 256 ASCII bytes. The blocks are terminated by a CR or any control character. Data is output from P1 in the format: /TXXLYYYMZZZ/CR/Data/CR/ where X is a two-digit ASCII line number, YYY is a three-digit ASCII-length number and ZZZ is a three-digit ASCII message number. The data concentrator holds the message buffer until an "A" is received. An "N" requests retransmission.

1.3 Installation

Unpack the GDC 2100 and visually inspect it for damage that might have occurred during shipping. If damage is noted, please notify General Digital Corporation. Each shipping container should contain:

- GDC 2100 Computer
- GDC 2100 Manual
- AC power cord
- two brackets

The unit is shipped set for 115VAC. If voltage change is required, consult section IV of this manual. The unit is installed by connecting P1 to the data output line and connectors P2, 1J0-1J3 and 2J0-2J3 to data lines from the sources. The unit is designed for table-top operation or optionally may be secured by removing the four rubber feet and attaching the two tie-down bars. Power is applied by the rear panel switch.

1.4 Specifications

The unit has slots for four dual wide boards. Three of these are factory installed. They are numbered 1-4 from top to bottom. Slot one has the KXT11 processor. Slots two and three have DLV11-J's installed. All serial lines are set for 1200 baud, 8 bits, one stop bit, no parity.

Slot 1 KXT11-AA	32 K bytes RAM (Socket B and local) 16 K BYTES ROM (Socket A) 60 HZ CLOCK SLU 1 CSR=177560 VECTOR 60 SLU 2 CSR= 120
Slot 2 DLV11-J	CSR=176500 VEC=300
Slot 3 DLV11J	CSR=176600 VEC=340

1.5 Troubleshooting

Due to the simple nature of the GDC-2100, there are only three things that can go wrong. The power supply, the processor, or one of the DLV11-J's can fail. On power-up, the processor executes a comprehensive "bit-walk" memory diagnostic; when power is applied, the LED on the KXT11 will blink on for one second and then go out for five seconds while the memory is tested. After this time, the LED will blink on a one-second interval.

Since General Digital has gone out of business the repair of the LSI has become a local issue. Since the LSI is comprised of standard DEC components, repairs should be able to be made whether by your local BME shop or a local repair vendor. If no local vendor is available your ISC can give you information on possible vendors to repair the LSI.

If one line fails (input from one source) replace the appropriate board. If the line is 1J0-1J3, replace the board in slot 2. If the line is 2J0-2J3, replace the board in slot 3. All other failures, will require more extensive repair and the whole unit will need to be sent out for repair. If a board is removed, the internal cabling may become confused. The cable has ten small connectors that are inserted into the boards with the wire going down. The left-most connector (brown, yellow, orange, red wires) goes to slot 1, J1 (the right-most of the two small sockets). The next connector to the right (green, gray, purple, blue wires) goes to slot 1, J2 (the left-most socket). The next four connectors to the right go to slot 2, in sequential order from right to left. The last four connectors go to slot 3 in sequential order from right to left.

Table 2-11 Summary of Console Selection Jumper Configurations

Label	Console selected	Console Not Selected
C1	Install jumper from wire wrap pins X to 1	Install jumper from wire wrap pins X to 0.
C2	Install jumper from wire wrap pins X to 1.	Install jumper from wire wrap pins X to 0.

2.2.3 Configuring Channel Word Formats

2.2.3.1 General - Each DLV11-J SLU channel can be individually configured for number of data bits (7 to 8); even, odd or no parity; 1 or 2 STOP bits, and baud rate (described in Paragraph 2.2.4). The serial character format is shown in Figure 2-6; jumper locations are shown in Figure 2-7; and a summary of possible character format jumper configurations is shown in Table 2-12.

2.2.3.2 Number of Data Bits - The serial character format for each channel can be configured for either seven or eight data bits. Three D (data) wire wrap posts are provided for the purpose of selecting the number of data bits per character for each channel. If seven data bits per character are desired, connect a jumper from wire wrap D pin X to pin 0. To configure eight data bits, connect the jumper from wire wrap D pin X to pin 1.

2.2.3.3 Number of STOP Bits - The serial character format for each channel can be configured for either one or two STOP bits. Configure one STOP bit operation by connecting a jumper between S (stop) wire wrap pin X and pin 0. To configure two STOP bits, connect a jumper from wire wrap S pin X to pin 1.

NOTE: The two STOP bits are generally only required for use with Teletype[®] terminals.

2.2.3.4 Parity Inhibit - Even, odd, or no parity bit generation and detection can be configured for each channel. If no parity bit generation or detection is desired, delete the bit by connecting a jumper between P (parity) wire wrap pins X and 1. If a parity bit is desired, connect P pins X and 0. Select even parity by connecting a jumper between E (even parity) wire wrap pin X and pin 1. Select odd parity by connecting a jumper between E pin X and pin 0.

NOTE: To prevent hardware damage within the channel, the E jumper must ALWAYS be installed. This is true regardless of the configuration of the P (parity) jumper.

Table 2-12 Summary of Character Format Jumper Configurations

UART		Wire wrap Connection		
		X to 0	X to 1	Comments
D	Number of data bits	7 bits	8 bits	LSB is transmitted first
S	Number of stop bits	1 bit	2 bits	
P	Parity inhibit	Parity generation and detection enabled	Parity generation and detection disabled	
E	Even parity enabled	Odd parity enabled	Even parity enabled	Requires P jumper connected from X to 0

NOTE: The E jumper must be connected to either 0 or 1, even if the parity bit is disabled.

2.2.4 Baud Rate - Each channel can be configured for baud rates ranging from 150 to 38400 bits/s. Baud rate jumpers are shown in Figure 2-7. One baud rate clock input wire wrap pin is provided for each channel (pins 0-3 and channels 0-3 respectively). Both transmitter and receiver functions for a given channel operate at the same baud rate; split baud rate operation is not provided.

NOTE: A 110 baud rate clock generator circuit is contained on the optional DLV11-KA 20 mA option. When 110 baud operation is desired, do not connect the baud rate jumper on the DLV11-J module for that particular channel. The 110 baud clock will be supplied by the DLV11-KA option through the interface connector.

Configure baud rates (except 110 baud) by connecting a jumper from an appropriate baud rate generator output wire wrap pin to the baud rate clock input pin (labeled 0-3); one jumper is required for each channel. Baud rate generator outputs are identified in Table 2-13.

NOTE: If more than one channel requires the same baud rate, wire wrap jumpers may be daisy-chained.

Table 2-13 Baud Rate Generator Outputs

Wire wrap Pin Label	Baud Rate (bits/s)
U	150
T	300
V	600
W	1200
Y	2400
L	4800
N	9600
K	19200
Z	38400

2.2.5 Channel 3 BREAK Response - Channel 3 (normally used as the console device) can respond to a BREAK condition on the receive line such as when an operator presses the BREAK key on the associated terminal. The BREAK key transmits a continuous space signal which is detected by the DLV11-J circuits as a framing error. If no operation is desired, do not connect jumpers to the B, X, and H wire wrap pins. Boot and Halt response are described as follows:

Boot - This function causes the processor to restart operation by executing a bootstrap program. The bootstrap program starts at memory location 173000 whenever a BREAK condition occurs on the receive data line; this will occur only if processor power-up mode 2 is configured on the processor module. Otherwise, the processor will respond to its configured power-up mode.

Configure the bootstrap response by connecting a jumper from wire wrap pin X to B.

Halt - This function causes the processor to halt whenever a BREAK condition occurs on the receive data line. This operation will occur regardless of the processor power-up mode configured on the processor module. Whenever the processor halts, console octal debugging technique (ODT) micro code is invoked.

Configure the BREAK response by connecting a jumper from wire wrap pins X to H.

The location of the BREAK response jumpers is shown in Figure 2-7 and a summary of possible configurations is shown in Table 2-14.

Table 2-14 Channel 3 BREAK Operation Jumper Summary

BREAK Response Operation	Jumper Connection
Boot	Install jumper between wire wrap pins X and B
Halt	Install jumper between wire wrap pins X and H
No response	No jumper installed

LSI GRAPHIC - PROCESSOR BOARD

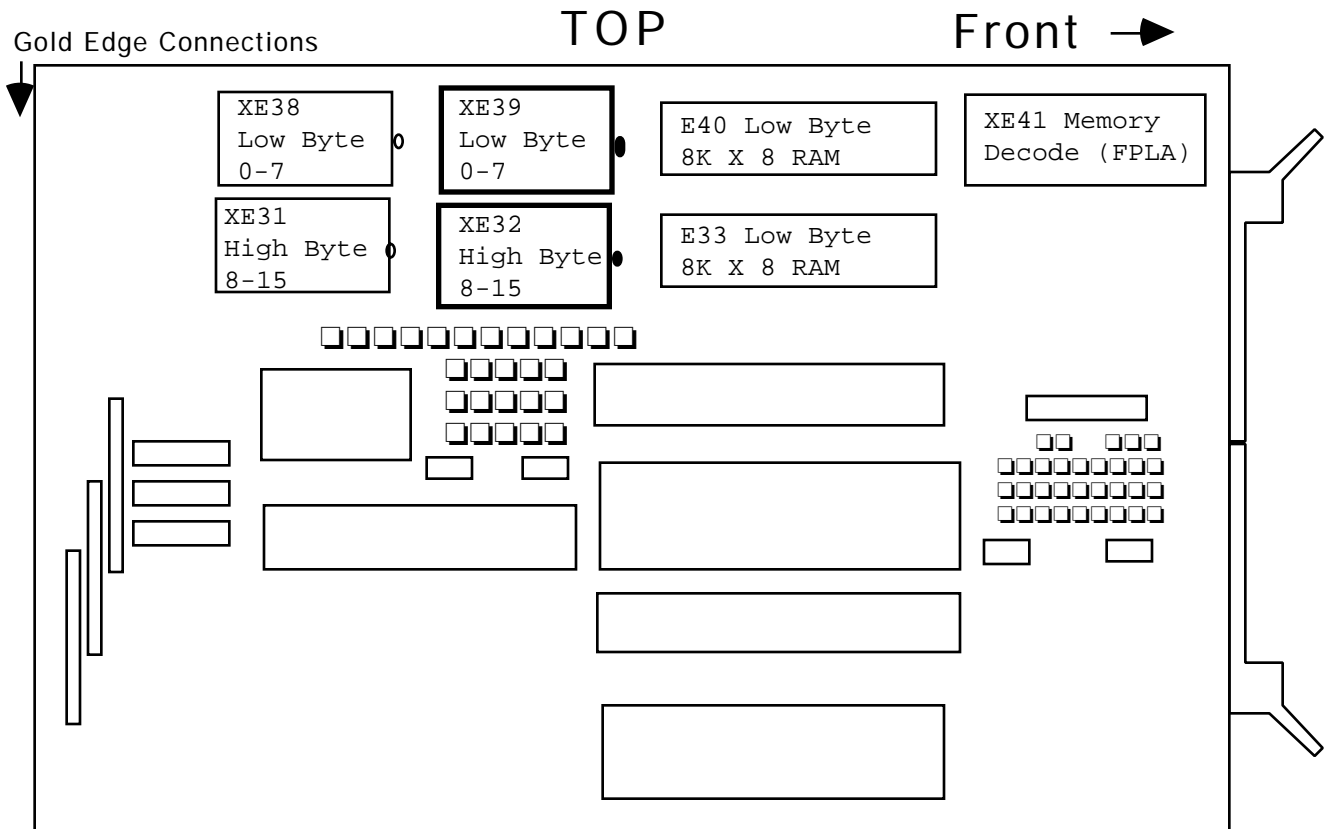

DLV11J DEC Board

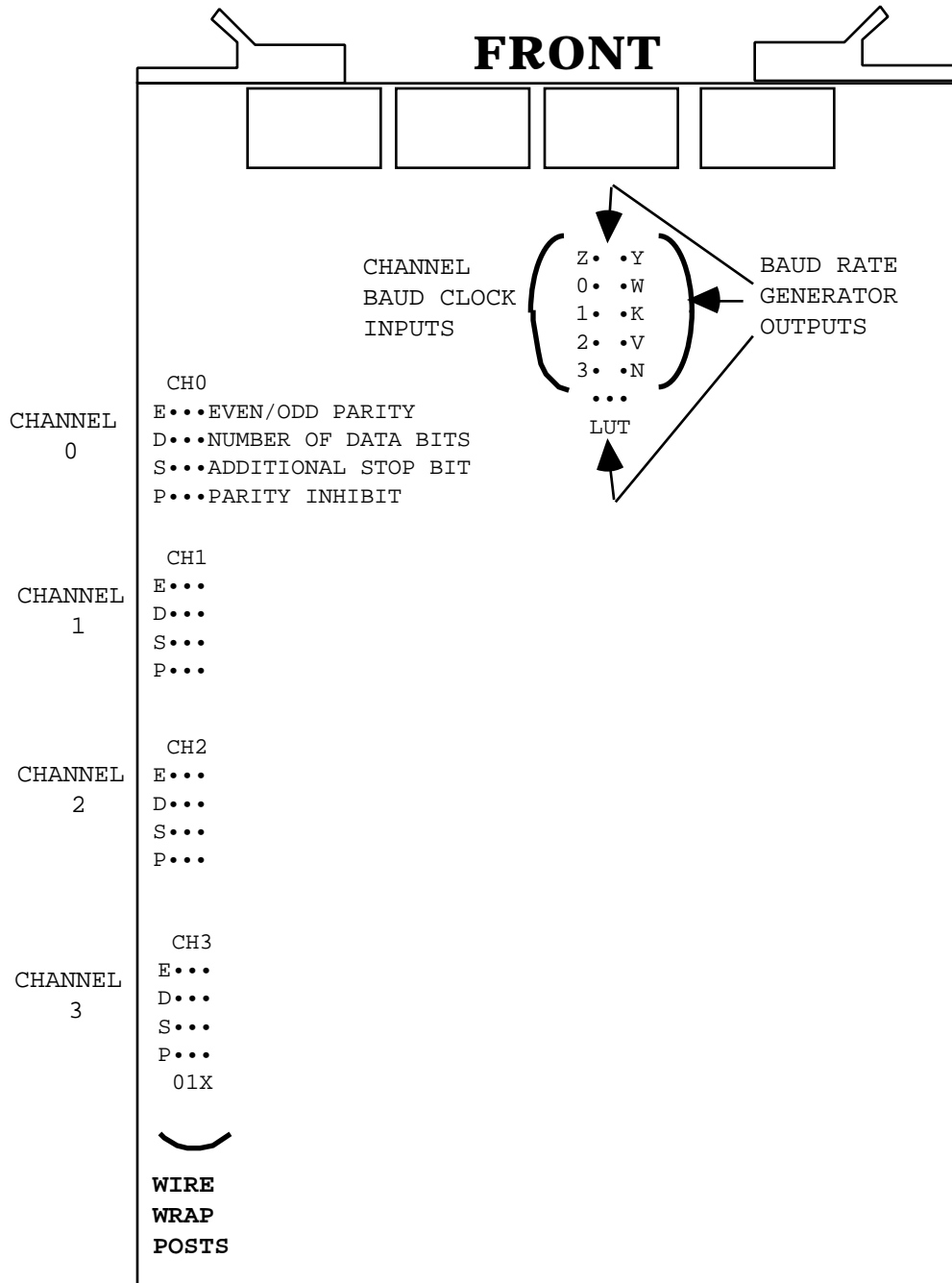

INDEX

Index

- *WARNING 45
- ? 268
- ? (option name) 268
- ?? 268
- ??? 268
- Anatomic Pathology 202
- ANTIMICROBIAL SUSCEPTIBILITY file 107, 124
- Archive Options 224
- Archiving of laboratory data from the ^LR global 221
- AUTO INSTRUMENT file 108, 126
- Automated Instrument Interface Specifications 75
- Automated Instrument Interfacing 49
- Automated Instruments Interface 77
- Bar Code Labels 95
- Batched Interim 41
- Bidirectional Communications 60
- Bidirectional Related Fields 63
- Blood Bank 202
- Brief File Descriptions 181
- Check a Single Routine Size 15
- Check Files for Inconsistencies [LRCHKFILES] 11
- Check Patient and Lab Data Cross Pointers [LRCKPTR] 13
- Clear data from the LAR global 225
- COLLECTION SAMPLE file 109
- Control code 74
- Cross References 209
- Cumulative Report 31
- Day One files 21
- DBA Integration Agreements 231
- Description of ^LA Global 90
- Description of ^LAH Global 90
- Device Parameters 38
- DHCP Laboratory Files 107
- Direct connect instruments 83
- Download Auto Micro Worklist 113
- Download Full Data 107
- Download Routine 63
- Echo Device 93
- Editing 16
- Entry or Exit Action 200
- Entry Point References 174
- ETIOLOGY FIELD file 107, 123
- Exported Options 189
- External Referenced Files and Fields 229
- External Relations 229
- External Routines 230

External Variables 230
File List 179
File Number Ranges 267
File Structure/Interaction 21
Force Cumulative Data to Permanent Page [LRAC FORCE] 221
Global Journaling 273
Handshake program 61
How To Print Data Dictionaries 269
Immediate Interim 41
Instrument Data Flow 47
Instrument Interface Troubleshooting 79
Instrument Routines 85
Interface 45
INTERFACE DATA OPTION MENU 111
Interface Testing 78
Interim Reports 39
Intermec 8646 Printer 98
Internal Relations 255
IRM personnel 231
LAB DATA file 123
Lab label 28
Lab Labels 28
Lab Routine Integrity Menu 14
LABORATORY DATA file 107
Laboratory Module Work Flow 7
Laboratory Security Keys 25
LABORATORY SITE file 107, 125
LABORATORY TEST file 124
LAPORTX X Routine 84
LAPX Routine 84
LIMs 231
Load Integrity File 15
LOAD/WORK LIST file 107, 125
Load/Work Lists 46
Local AUTO INSTRUMENT files 82
Loop thru LR Integrity 15
LRLABEL4 29
LRTASK Options 204
LSI 100
LSI Graphic 67
LSI Wire Wrapping 71
Mapping Routines 277
Menu Description 24
Microfiche of Path Reports 30
MicroScan File Setup 105
MicroScan Interface 100
Namespacing 267
New Data Names 19
Non VA FileMan Compatible Globals 90

Note Box 8
OE/RR documentation 147
OE/RR Routines 170
On-line Help From Your Terminal Screen 268
On-Line Help Using Kernel 267
OTC 800 Printer 96
Package-Wide Variables 259
Pin Definitions 78
Planning and Implementation Guide 23, 27, 30, 123, 181
Preimplementation files 22
Processing Routine 62
Purge Old Orders and Accessions [LROC] 223
Read Data from Off-Line Media 225
Required Software 230
RJ11 100
Routine Descriptions 151
RS-232 45
Search for Lab Data to Archive 225
Security Keys 201
Special Templates 267
Stand Alone Menus 255
Standards and Conventions Committee (SACC) Exemptions 263
Supervisors/Choosers of Instrumentation 45
Supported References 173
System Integrity Checks 11
Tasking the Interim 41
TaskManager 37
TOPOGRAPHY FIELD file (61)
Troubleshooting for VITEK 133
Version 2 LSI Eprom Installation 65
VITEK File Setup 119
VITEK Interface 114
VITEK Interface Instructions 114
WARNING 38, 47, 66, 127, 131
Warning Symbol 8
Wire Wrap Tool 71
Wiring Diagrams and Pin Definitions for Automated Instruments 75
Workload Recording 26