

This document contains FAQs that were approved since the last revision of NEI 99-02. The following table has the most recently approved FAQs toward the top of the list.

Database #	FAQ #	PI	Site-Specific or Generic	Subject	Effective Date
TBD	12-03	IE04	St. Lucie 1	Unplanned Scram with Complications definition and exemption request	10/01/2012
TBD	12-02	PP01	Generic	Compensatory Hours for Perimeter Intrusion Detection System	10/01/2012
N/A (withdrawn)	12-01	MS06	Columbia	EDG Failure	N/A
TBD	11-13	EP03	Generic	Suspension of siren testing for weather-related issues	04/01/2012
TBD	11-12	IE03	FitzPatrick	Condenser Fouling	01/19/2012
TBD	11-10	PP01	Site-Specific	Compensatory Hours (Not publicly available. Contact the NEI or NRC ROPWG representative for additional information)	01/19/2012
N/A (withdrawn)	11-09	IE04 MSPI	Crystal River 3	Extended Shutdown	N/A
TBD	11-08	MS06	Generic	EDG Failure Definitions	04/01/2012
TBD	10-06	MSPI	Generic	Cascaded UA	04/01/2012
485	11-11	EP03	Fort Calhoun	Weather-related ANS testing issues	04/01/2011
484	11-07	MS06	Generic	FOTP in EDG super-component boundary	01/01/2012
483	11-04	IE03	Generic	Loss of Equipment Recovery	10/01/2011
482	11-01	MS10	Generic	Cooling Water Boundary	10/01/2011
481	10-02	IE04	Generic	MFW & Scrams	10/01/2011
480	11-06	MS06	Generic	EDG Run Hours	01/01/2012
479	11-05	MS08	Point Beach 1&2	AFW Modification	04/01/2011
478	11-03	IE04	H.B. Robinson	MFW & Scrams	02/16/2011
477	11-02	MSPI	Generic	MSPI Basis Doc Updates	10/01/2011
476	09-10	EP02	Generic	Drill Participation	07/01/2011
475	10-05	IE04	Palo Verde	LOFC EOP	07/01/2010
474	10-03	IE04	Wolf Creek	MFW & Scrams	07/01/2010
473	10-04	MSPI	Browns Ferry 1	CCF Adj Values	07/01/2010
472	09-08	MSPI	Generic	PMT & Availability	04/01/2010
471	09-06	EP01	Generic/ Duane Arnold	Offsite Call Simulation	07/01/2010
470	10-01	N/A	Generic	FAQ Withdrawal	04/01/2010
469	09-09	IE03	Generic	Clarifications	03/18/2010
468	09-07	MSPI	Generic	Baseline UA	04/01/2010
467	09-04	IE04	Brunswick	MFW & Scrams	10/15/2009

## FAQs - By Cornerstone/PI

Number	Cornerstone	PIs	Date Entered	
470			3/18/2010	<p><b><u>Question</u></b> Existing Guidance on Page E-3 beginning at line 16</p> <p><u>Withdrawal of FAQs</u></p> <p>A licensee may withdraw a FAQ after it has been accepted by the joint ROP Working Group. Withdrawals must occur during an ROP Working Group monthly (approximately) meeting. However, the ROP Working Group should further discuss and decide if a guidance issue exists in NEI 99-02 that requires additional clarification. If additional clarification is needed then the original FAQ should be revised to become a generic FAQ.</p> <p>Event or circumstances requiring guidance interpretation</p> <p>The staff has expressed concern that when a licensee withdraws an FAQ, the efforts that they expend during the discussions preceding the withdrawal of the FAQ are not captured.</p> <p>If licensee and NRC resident/region do not agree on the facts and circumstances explain</p> <p>NA</p> <p><b><u>Response</u></b> Proposed Resolution of FAQ</p> <p style="text-align: center;"><u>Recommended Change</u></p> <p><u>Withdrawal of FAQs</u></p> <p>A licensee may withdraw a FAQ after it has been accepted by the joint ROP Working Group. Withdrawals must occur during an ROP Working Group meeting. However, the ROP Working Group should further discuss and decide if a guidance issue exists in NEI 99-02 that requires additional clarification. If additional clarification is needed then the original FAQ should be revised to become a generic FAQ. In many cases, there are</p>

## FAQs - By Cornerstone/PI

Number	Cornerstone	PIs	Date Entered	
				<p>lessons learned from the resources expended by the ROP Working Group that should be captured. In those cases, the FAQ will be entered in the FAQ log as a generic FAQ. If there is disagreement between the staff and industry, both positions should be articulated in the FAQ. These withdrawn FAQs should be considered as historical and are not considered to be part of NEI 99-02. Although they do not establish precedence, they do offer insights into perspectives of both industry and NRC staff and, as such, can inform future decisions to submit an FAQ.</p> <p>If appropriate, provide proposed rewording of guidance for inclusion in next revision.</p> <p>See proposed resolution</p>

FAQs - By Cornerstone/PI  
Emergency Preparedness  
EP01 – Drill/Exercise Performance

Number	Cornerstone	PIs	Date Entered	
--------	-------------	-----	--------------	--

471	EP	EP01	4/21/2010	
-----	----	------	-----------	--

**Question**

**NEI 99-02 Guidance needing interpretation (include page and line citation):**

NEI 99-02, Rev. 6 page 45, lines 43 – 46:

*Performance statistics from operating shift simulator training evaluations may be included in this indicator only when the scope requires classification. Classification, PAR notifications and PARs may be included in this indicator if they are performed to the point of filling out the appropriate forms and demonstrating sufficient knowledge to perform the actual notification.*

NEI 99-02, Rev. 6 page 46, lines 17 – 19:

*Simulation of notification to offsite agencies is allowed. It is not expected that State/local agencies be available to support all drills conducted by licensees. The drill should reasonably simulate the contact and the participants should demonstrate their ability to use the equipment.*

**Event or circumstances requiring guidance interpretation:**

In accordance with Duane Arnold Energy Center (DAEC) procedures for making offsite notifications of emergency events, the Shift Technical Advisor (Key Communicator) fills out the notification form, gains approval from the Shift Manager (Key Decision Maker/Emergency Director), and hands the form off to the Security Shift Supervisor (not filling an NRC Participation PI key position). The Security Shift Supervisor then contacts offsite authorities using a telephone system (one call notifies all county and state authorities).

During licensed operator continuing training simulator evaluations, Security personnel are sometimes not available to participate. In these cases, the simulator instructor/evaluator role-plays as the Security Shift Supervisor. When this occurs, the

FAQs - By Cornerstone/PI  
Emergency Preparedness  
EP01 – Drill/Exercise Performance

Number	Cornerstone	PIs	Date Entered
			<p>instructor does not pick up the phone and simulate making a call to offsite authorities.</p> <p>The NRC resident has challenged counting these as successful DEP opportunities because there is no demonstration of using the phone equipment.</p> <p>NEI 99-02, Rev. 6 seems to differentiate the extent of demonstrating notification between operations simulator evaluations and drills. This is also discussed in a previous FAQ 202.</p> <p>What extent of simulation is required to “demonstrate sufficient knowledge to perform actual notification”? Should “demonstration of their ability to use the equipment” be applied to operations simulator evaluations?</p> <p>In the simulator evaluations in question, the simulator scenario was developed to have the instructor role-play as the Shift Security Supervisor and did not require any participant to demonstrate use of the phone if security personnel were not available. If these instances do not meet the intent for demonstrating sufficient knowledge of performing notifications and there were no errors made by the participants, should these opportunities be counted in the performance indicator as failures?</p> <p><b>If licensee and NRC resident/region do not agree on the facts and circumstances explain</b></p> <p>The NRC has concluded that the opportunities are failures due to not demonstrating the use of phone equipment.</p> <p><b>Potentially relevant existing FAQ numbers</b></p> <p>None</p>

FAQs - By Cornerstone/PI  
Emergency Preparedness  
EP01 – Drill/Exercise Performance

Number	Cornerstone	PIs	Date Entered
--------	-------------	-----	--------------

**Response**

**Proposed Resolution of FAQ**

During operator simulator training, personnel filling a non-key position for making a phone call to offsite agencies may not be available. In these instances where the Shift Manager (Emergency Director) and the Shift Communicator do not perform the notification phone call, it is acceptable to demonstrate the notification process up to the point of filling out the appropriate forms and providing the completed notification forms to a person role-playing as the phone-talker.

At a later time an off sequence phone talker will complete the process of using the telecommunications equipment.

Past opportunities performed by Licensees in a similar manner as the FAQ submitter will not require revision. Data will be collected using this new process going forward from the effective date of this FAQ.

The following additional clarifying information is provided to ensure consistent implementation of the proposed rewording of guidance added to NEI 99-02, Rev. 6 page 45, lines 43 – 46:

- What happens if an inspector identifies a licensee did not demonstrate the use of communications equipment and procedures for evaluation associated with a particular simulator session? If an inspector identifies a classification/notification performance, which was counted in the PI data, which did not include a demonstration of the communications equipment that performance is to be removed from the DEP PI calculation. The performance would not be considered a success or failure.
- Can one out-of-sequence phone talker activity evaluation be tied to multiple

FAQs - By Cornerstone/PI  
 Emergency Preparedness  
 EP01 – Drill/Exercise Performance

Number	Cornerstone	PIs	Date Entered
--------	-------------	-----	--------------

in-simulator classification / notification performances, or is a one-to-one correspondence required? A one-to-one out-of-sequence phone talker activity evaluation correspondence is required for each classification / notification performance.

- Does the out-of-sequence activity have to take place within any specified time period? Yes, the out-of-sequence communicator evaluation must be completed during the quarter the classification/notification was made.
- Will licensees be required to identify which out-of-sequence communicator evaluation(s) was/were connected to which in-simulator performance(s)? Yes. In order to evaluate the timeliness aspect of the DEP Notification opportunity, the documentation needs to be clear for each Notification opportunity as to how long the Notification process took:
  - In the Simulator and,
  - How long it took the phone talker to complete the same notification by use of the communications equipment to contact the first offsite stakeholder.

The licensee needs to provide sufficient documentation to enable an inspector to arrive at the same conclusion the licensees did concerning timeliness of the Notification.

- Performance opportunities for the Out-of-sequence phone talker activities are expected, to the extent reasonable, to be made available to all qualified ERO phone talkers and performed by most of the qualified individuals. However, there is no intent by this FAQ to track phone talkers for participation purposes.

**If appropriate, provide proposed rewording of guidance for inclusion in next revision.**

FAQs - By Cornerstone/PI  
Emergency Preparedness  
EP01 – Drill/Exercise Performance

Number	Cornerstone	PIs	Date Entered
--------	-------------	-----	--------------

NEI 99-02, Rev. 6 page 45, lines 43 – 46:

Current wording is italicized, proposed additions are underlined.

*Performance statistics from operating shift simulator training evaluations may be included in this indicator only when the scope requires classification. Classification, PAR notifications and PARs may be included in this indicator if they are performed to the point of filling out the appropriate forms and demonstrating sufficient knowledge to perform the actual notification: demonstrating sufficient knowledge” is defined as demonstrating the use of communications equipment to contact the first offsite stakeholder for the purpose of transmitting initial notification information(offsite stakeholder maybe role played) in accordance with site communication procedure(s), as well as, if used, demonstration of the needed interface between the key ERO communicator and the phone-talker. It is recognized that key control room positions may not perform the actual communication with offsite agencies as part of the notification process. Personnel filling non-key positions for contacting offsite agencies (phone-talker) may not be available during simulator training. If an evaluator role-plays the phone talker during the simulator session, a phone talker is required to complete the notification process out of sequence (e.g. notification form completed in the simulator is provided to a phone talker at a later time and the phone talker demonstrates use of the telephone equipment to an evaluator). Interactions normally between the Key Communicator and the phone talker (e.g. receiving instruction, discussion of the notification and correction of errors in the notification form) occur between the phone talker and an evaluator role playing the Key Communicator for this off sequence demonstration. Timeliness is determined by adding the time required to complete the notification form in the simulator to the time required by the phone talker to interact and then utilize the communications equipment out of sequence.*

[Text continues with page 45, Line 47, “However, there is no intent to disrupt ongoing operator qualification programs...”]



FAQs - By Cornerstone/PI

Initiating Events

EP02 – ERO Drill Participation

Number	Cornerstone	PIs	Date Entered	
476	EP	EP02	2/16/2011	<b>Question</b> <b>NEI 99-02 Guidance needing interpretation (include page and line citation):</b> Page 50, Lines 3-13

**Purpose**

This indicator tracks the participation of ERO members assigned to fill Key Positions in performance enhancing experiences, and through linkage to the DEP indicator ensures that the risk significant aspects of classification, notification, and PAR development are evaluated and included in the PI process. This indicator measures the percentage of ERO members assigned to fill Key Positions who have participated recently in performance-enhancing experiences such as drills, exercises, or in an actual event.

**Indicator Definition**

The percentage of ERO members assigned to fill Key Positions that have participated in a drill, exercise, or actual event during the previous eight quarters, as measured on the last calendar day of the quarter. [bolding is in original]

**Event or circumstances requiring guidance interpretation:**

The event or circumstance involves utilities with common Emergency Operations Facilities (EOFs) where the functions of EOF Senior Manager, EOF Key Protective Measures and EOF Communicator are assigned to Key Positions that support multiple nuclear sites. ERO members assigned to each function are grouped and monitored to ensure that each receives a “meaningful opportunity to gain proficiency”. These opportunities are accounted for at the end of each quarter and reported through the ROP process.

Where an ERO member is assigned to fill a Key Position supporting multiple nuclear units, the ERO member is trained to support each unit served. Units may be at one site or multiple sites. ERO members receive initial and continuing training on site and unit-specific procedures, processes and protocols as well as involvement in a drill and

FAQs - By Cornerstone/PI

Initiating Events

EP02 – ERO Drill Participation

Number	Cornerstone	PIs	Date Entered
--------	-------------	-----	--------------

exercise programs that support both. This ensures the skill sets needed are similar in application regardless of the nuclear unit involved.

The clarification being sought would allow granting of Participation Credit to an ERO member, assigned to fill a Key Position supporting multiple nuclear units, for all the sites served by that member when provided with a meaningful opportunity to gain proficiency during a drill or exercise at any of the supported nuclear units.

**If licensee and NRC resident/region do not agree on the facts and circumstances explain**

NRC does not agree with the current method for granting participation credit for common EOFs and has specified that participation credit can be provided only to the specific site involved in the drill or exercise.

**Potentially relevant existing FAQ numbers:** None identified.

**Response**

**Proposed Resolution of FAQ**

Revise NEI 99-02, Section 2.4, to provide the option of an alternate methodology that would allow participation credit for the common facility to be counted across all units or sites supported by that facility. The common facility could include an Emergency Operations Facility, Technical Support Center, or Operational Support Center. The alternate methodology could be elected for a common facility serving either multiple units or sites or serving units with different technologies, provided the following five conditions are met:

1. The functions of Classification, Protective Action Recommendations (PARs), Dose Assessment, and Emergency Notifications are performed similarly (an ERO member, assigned to fill a Key Position supporting multiple nuclear

FAQs - By Cornerstone/PI

Initiating Events

EP02 – ERO Drill Participation

Number	Cornerstone	PIs	Date Entered
--------	-------------	-----	--------------

units may not perform all 4 functions, therefore this requirement only applies to the functions performed by that ERO member ) for each unit served by the common facility.

2. The link between the Drill and Exercise Performance (DEP) indicator and the ERO Drill Participation indicator is maintained by granting DEP credit (both success and failure) from one drill or exercise to all units served by the common facility.
3. Lessons learned through the common facility are shared with all the nuclear units or sites that are supported by the common facility.
4. Corrective actions associated with Key Positions in the ERO are applied to each unit or site served by the common facility.
5. Initial and continuing position specific training is required for Key ERO positions to include at a minimum all position tasks associated with RSPS. Lesson plans, rosters, records, are available for NRC inspection.

**If appropriate, provide proposed rewording of guidance for inclusion in next revision.**

\*\*\*\*\*

***[DRILL AND EXERCISE PERFORMANCE]***

*NEI 99-02 Revision 6, Section 2.4, page 45, "Clarifying Notes"*

33 If credit for an opportunity is given in the ERO Drill Participation performance indicator, then

34 that opportunity must be included in the drill/exercise performance indicator.

For example, if the

35 communicator performing the entire notification during performance enhancing scenario is an

36 ERO member in a Key Position, then the notification may be considered as an

FAQs - By Cornerstone/PI

Initiating Events

EP02 – ERO Drill Participation

Number	Cornerstone	PIs	Date Entered
--------	-------------	-----	--------------

opportunity and, if  
37 so, participation credit awarded to the ERO member in the Key Position.  
38

*[New text to be inserted at Line 38]*

If an ERO member in a Key Position supports multiple units (at one or more sites), Drill/Exercise Performance (DEP) opportunities performed by the ERO member may be credited to all sites potentially served by the ERO member, in addition to the specific site participating in the drill or exercise.

39 When a performance enhancing experience occurs before an individual is  
assigned to a Key  
40 Position in the ERO, then opportunities for that individual that were identified  
in advance shall  
41 contribute to the Drill/Exercise (DEP) metric at the time the member is  
assigned to the ERO.  
42

\*\*\*\*\*

**[PARTICIPATION]**

*NEI 99-02 Revision 6, page 50, "Data Reporting Elements"*

*[New text to be inserted at Line 24]*

The participation indicator may include participation in a facility that supports multiple units.

**25 Calculation**

26 The site indicator is calculated as follows:  
27

*NEI 99-02 Revision 6, page 51, "Clarifying Notes"*

41 inspection.  
42

## FAQs - By Cornerstone/PI

### Initiating Events

#### EP02 – ERO Drill Participation

Number	Cornerstone	PIs	Date Entered
--------	-------------	-----	--------------

*[New text to be inserted at Line 42]*

#### **Option for Emergency Response Organizations with Common Facilities**

If an ERO member in a Key Position supports multiple units (at one or more sites) and demonstrates similar skill sets during a performance-enhancing experience, participation credit may be granted for all sites supported.

Negative performance credit as well as positive performance credit will be assigned to all units.

#### **Similarity of Skill Sets**

Skill sets are considered similar when the procedures, processes and protocols involved accomplish the same task or goal. Examples of similar skill sets are provided below:

#### **Classification**

Classification of Emergencies, are similar when Emergency Action Level procedures, processes and protocols used by the ERO members in the Key Position are essentially the same (for example all units would use NEI 99-01 or in the case where a unit may be an advanced passive light water reactor it would be acceptable to utilize NEI 99-01 for existing technology and NEI 07-01 for passive technology). Training for key ERO members performing this function is to include unit-specific and/or technology differences relating to Initiating Conditions/Emergency Action Levels (e.g., ISFSI, unique hazards, design considerations, etc.).

#### **Protective Action Recommendations (PARs)**

## FAQs - By Cornerstone/PI

### Initiating Events

#### EP02 – ERO Drill Participation

Number	Cornerstone	PIs	Date Entered
--------	-------------	-----	--------------

Protective Action Recommendations, when developed with the same protective action strategies, are similar provided that the procedures, processes and protocols for the development of the protective action recommendations are essentially the same. For example:

- Logic flow charts may differ (e.g., because of population differences among the sites), but should serve the same purpose and be used in the same way.
- Protective Action Zones may differ, but the process used to identify the action taken for the zones is the same.
- Implementation of potassium iodide (KI) strategies may differ based on the implementation strategies of responsible authorities at the State and/or Local level, but the procedures, processes and protocols used to determine if KI is warranted should be the same.
- PAR development discussion strategies should be the same for each site supported by the common facility.

#### **Dose Assessment**

Dose assessment is similar when methodologies, applicable computer programs, and models are the same across sites and/or unit technologies served by the common facility. Definitions of what constitutes a radiological release during a classified emergency are the same. Training for key ERO members performing this function must include unit-specific differences in effluent monitors and release pathways, local meteorological regimes and topography impacts and how these differences impact the dose assessment.

#### **Emergency Notifications**

The emergency communicator functions are similar when procedures, processes and protocols are performed utilizing a similar emergency notification form

FAQs - By Cornerstone/PI

Initiating Events

EP02 – ERO Drill Participation

Number	Cornerstone	PIs	Date Entered
--------	-------------	-----	--------------

design and content. Emergency communicators will be trained on all notification procedures, processes and protocol differences including, but not limited to, offsite contacts, form content, methods and equipment.

**Link to Drill and Exercise Performance**

Lessons learned (positive and negative) are shared to ensure that the benefits of the performance enhancing experience of the key ERO member(s) are applied across all units. Corrective actions from the performance of key ERO members performing DEP activities are shared with and applied to all key ERO members of all units. Similarly, corrective actions associated with common facility Key ERO member performance (e.g. training or qualification gaps, procedure deficiencies, equipment issues) are applied across all units corrective action programs. DEP opportunities performed shall be credited to all units, in addition to the unit participating in the drill or exercise.

**Records**

Lesson plans, rosters, records, etc., are available for NRC inspection.

[End of Notes on Option for EROs with Common Facilities]

- 43 Credit can be granted to Key Positions for ERO Participation for a Security related Drill or
- 44 Exercise as long as the Key Positions are observed evaluating the need to upgrade to the next

\*\*\*\*\*

NRC Response to FAQ:

The staff agrees with the proposed wording changes and with the effective date of 3rd Quarter 2011.

FAQs - By Cornerstone/PI  
Initiating Events  
EP02 – ERO Drill Participation

Number	Cornerstone	PIs	Date Entered	
--------	-------------	-----	--------------	--



FAQs - By Cornerstone/PI

Initiating Events

EP03 – Alert and Notification System (ANS) Reliability

Number	Cornerstone	PIs	Date Entered	
485	EP	EP03	9/21/2011	<b><u>Question</u></b>

**NEI 99-02 Guidance needing interpretation (include page and line citation):**

ANS page 57 lines 6 through 10

6 If a siren is out of service for maintenance or is inoperable at the time a regularly scheduled test  
7 is conducted, then it counts as both a siren test and a siren failure. Regularly scheduled tests  
8 missed for reasons other than siren unavailability (e.g., out of service for planned maintenance or  
9 repair) should be considered non opportunities. The failure to perform a regularly scheduled test  
10 should be noted in the comment field.

**Event or circumstances requiring guidance interpretation:**

This document details the decision process for reporting Alert Notification System siren status on NRC Performance indicators during the Flooding event of the spring and summer of 2011.

Under normal circumstances and in accordance with the Fort Calhoun Radiological Emergency Response Plan, section E, sirens are tested bi-weekly for functionality via Emergency Planning Test (EPT) EPT-1 (Alert Notification System Silent Test), quarterly via EPT-2 (Alert Notification System Growl Test), and annually via EPT-3 (Alert Notification System Complete Cycle Test).

Current flooding along the Missouri River and within the 10-mile EPZ has resulted in several sirens being [deliberately] disabled by disconnecting AC power due to rising river levels. These flooding conditions do not only affect the operability/functionality of the sirens, but have also resulted in power disconnections for and evacuation of residents in the areas for which these sirens provide coverage. Additionally, backup route-alerting is

## FAQs - By Cornerstone/PI

### Initiating Events

#### EP03 – Alert and Notification System (ANS) Reliability

Number	Cornerstone	PIs	Date Entered	
				<p>still available for any remaining affected residents as verified through local and state governments.</p> <p>In accordance with NEI 99-02, Revision 6 (Regulatory Assessment Performance Indicator Guideline), page 57 concerning siren testing states “Regularly scheduled tests missed for reasons other than siren unavailability (e.g., out of service for planned maintenance or repair) should be considered non opportunities.” This evaluation and exemption was applied to the sirens that have been removed from service due to flooding.</p> <p>These sirens were removed from service intentionally, and will remain out of service for an extended period of time; therefore will not be counted in the performance indicator for Alert and Notification System Reliability. For all EPTs conducted on sirens during the time period when power has been removed from the siren due to flooding, the number of sirens tested will only be those that have normal power available.</p> <p><b>If licensee and NRC resident/region do not agree on the facts and circumstances explain</b></p> <p>The NRC concurs with what is in the FAQ. The NRC indicated that they agreed with our conclusion. (Initial)</p> <p><b>Potentially relevant existing FAQ numbers</b></p> <p>Grand Gulf Plant Specific FAQ in NEI 99-02 rev 6, appendix D, page D2. [During processing by the ROPTF, this Fort Calhoun FAQ was identified as FAQ 11-11.]</p> <p><b><u>Response</u></b></p> <p><b>Proposed Resolution of FAQ</b></p> <p>Appendix D of NEI 99-02 will be updated to include the following resolution of this issue</p>

FAQs - By Cornerstone/PI

Initiating Events

EP03 – Alert and Notification System (ANS) Reliability

Number	Cornerstone	PIs	Date Entered	
--------	-------------	-----	--------------	--

for Fort Calhoun:

If sirens are not available for operation due to high flood water conditions, and the area is deemed inaccessible and uninhabitable by State and/or Local agencies, the siren(s) in question will not be counted in the numerator or denominator of the Performance Indicator for that testing period.

***NRC Response:***

NRC staff agrees with the proposed resolution and the effective date of 2Q2011 and forward. A generic FAQ should be submitted.

FAQs - By Cornerstone/PI

Initiating Events

IE03 – Unplanned Power Changes per 7,000 Critical Hours

Number	Cornerstone	PIs	Date Entered	
483	IE	IE03	9/21/2011	<u>Question</u>

**NEI 99-02 Guidance needing interpretation (include page and line citation):**

Page 13, Lines 24 – 29

**Event or circumstances requiring guidance interpretation:**

At 0707 hours on June 4, 2010, the Perry Plant entered single loop operation (SLO) when reactor recirculation pump A tripped OFF due to a failed optical isolator card. Reactor power in SLO was approximately 58% RTP. This power change is counted under the unplanned power change PI because the power change was greater than 20% (100% to 58%) and was initiated less than 72 hours following discovery of the off-normal condition.

After replacing the optical isolator card, power reduction to approximately 21% was necessary to establish reactor conditions necessary to restart reactor recirculation pump A and commence power ascension. The power reduction began at 2220 hours on June 4, 2010 and ended at 1827 hours on June 5, 2010. The second power reduction was also counted as an unplanned power change because the power change was greater than 20% (58% to 21%) and was initiated less than 72 hours following discovery of the off-normal condition.

The question being asked in this case is whether the second power reduction should be counted as a separate occurrence. Clearly, the second power reduction was implemented to address the initial condition (i.e., reactor recirculation pump A trip). It is not desirable for a boiling water reactor (BWR) to operate in SLO for long periods of time, although SLO is a licensed operating mode. The reactor has to be brought to a condition with adequate margins to thermal limits and stability in order to re-start

FAQs - By Cornerstone/PI

Initiating Events

IE03 – Unplanned Power Changes per 7,000 Critical Hours

Number	Cornerstone	PIs	Date Entered	
				<p>the non-operating recirculation pump after repairs are completed. In this case, a power reduction is necessary to reach this condition. The operating recirculation pump has to be transferred to slow speed. Then, the non-operating pump is started in slow speed at the desired power level. Power ascension may commence with both pumps running in slow speed.</p> <p>The Unplanned Power Changes per 7,000 Critical Hours PI monitors the number of unplanned power changes that could have, under other plant conditions, challenged safety functions. Operating in SLO in accordance with Technical Specifications does not challenge nuclear safety or is in itself, risk-significant. Therefore, a second power reduction to recover a non-operating recirculation pump does not appear to be within the intent of the PI.</p> <p>The guidance on NEI 99-02 page 14 lines 23 through 30 and beginning on line 42 indicates that power changes resulting from proper implementation of preexisting procedural guidance which are not in response to an equipment failure or personnel error are not meant to be counted by this indicator. This is in direct contrast to power changes resulting from equipment failures or personnel errors. Consistent with this guidance, power changes to restore equipment to service in accordance with approved procedures do not count. This exception does not apply to downpowers that are conducted to perform corrective maintenance.</p> <p>Guidance in NEI 99-02 is requested to clarify reporting criteria for situations similar to the Perry event, where a power reduction is required to place equipment in service, such as to recover a non-operating reactor recirculation pump. No clarification is needed for the initial trip to enter SLO which will be counted and reported under the PI.</p>

**If licensee and NRC resident/region do not agree on the facts and circumstances,**

## FAQs - By Cornerstone/PI

### Initiating Events

#### IE03 – Unplanned Power Changes per 7,000 Critical Hours

Number	Cornerstone	PIs	Date Entered
--------	-------------	-----	--------------

#### **explain**

The NRC resident inspector agrees with the facts as stated in the FAQ. In the Perry case that initiated this FAQ, both unplanned power changes were reported. The NRC inspector believes that NEI 99-02, as written, requires two unplanned power changes to be reported.

#### **Potentially relevant existing FAQ numbers**

None identified. [During ROPTF review, this FAQ was identified as FAQ 11-04.]

#### **Response**

#### **Proposed Resolution of FAQ**

Power changes implemented less than 72 hours from time of discovery, in accordance with approved procedures, for the purpose of placing equipment in service, such as restarting a non-operating reactor recirculation pump in a BWR plant or a heater drain pump, should not be reported under this PI. The initiating event or condition that resulted in the need to restore the equipment is the event that is evaluated under this PI.

If appropriate, provide proposed rewording of guidance for inclusion in next revision.

Add to Clarifying Notes for Unplanned Power Changes per 7,000 Critical Hours in NEI 99-02, page 14:

## FAQs - By Cornerstone/PI

### Initiating Events

#### IE03 – Unplanned Power Changes per 7,000 Critical Hours

Number	Cornerstone	PIs	Date Entered
--------	-------------	-----	--------------

#### Current Guidance:

- 16 Unplanned power changes and shutdowns include those conducted in response to equipment  
17 failures or personnel errors and those conducted to perform maintenance. They do not include  
18 automatic or manual scrams or load-follow power changes.

Add the following to the end of the sentence on line 17:

Power changes to restore equipment to service in accordance with approved procedures are excluded.

#### Current Guidance:

- 23 Unplanned power changes include runbacks and power oscillations greater than 20% of full  
24 power. A power oscillation that results in an unplanned power decrease of greater than 20%  
25 followed by an unplanned power increase of 20% should be counted as two separate PI events,  
26 unless the power restoration is implemented using approved procedures. For example, an  
27 operator mistakenly opens a breaker causing a recirculation flow decrease and a decrease in  
28 power of greater than 20%. The operator, hearing an alarm, suspects it was caused by his  
29 action  
29 and closes the breaker resulting in a power increase of greater than 20%. Both transients would  
30 count since they were the result of two separate errors (or unplanned/non-proceduralized  
action).

Add the following to the end of line 30:

Alternately, if the power change is implemented to restore equipment to service and is performed using an approved procedure, the power change(s) (increases or decreases) to restore the equipment to service would not count against this indicator. For example, in BWRs, a power reduction for the purpose of re-starting a recently tripped reactor recirculation pump to re-establish two-loop operation is excluded if the initial power reduction is caused by the recirculation pump trip. The second power reduction to recover the tripped recirculation pump does not

FAQs - By Cornerstone/PI

Initiating Events

IE03 – Unplanned Power Changes per 7,000 Critical Hours

Number	Cornerstone	PIs	Date Entered	
				count if it is implemented by an approved procedure in response to the initial condition.

**NRC Response to FAQ:**

The staff agrees with the Proposed Resolution of FAQ and an effective date of October 1, 2011, meaning that the FAQ resolution will begin to be applied to 4Q2011 data to be reported to NRC in January 2012.

469	IE	IE03	3/18/2010	<p><b><u>Question</u></b>  <b><u>UNPLANNED POWER CHANGES PER 7,000 CRITICAL HOURS</u></b></p>
-----	----	------	-----------	---------------------------------------------------------------------------------------------------

**Purpose**

This indicator monitors the number of unplanned power changes (excluding scrams) that could have, under other plant conditions, challenged safety functions. It may provide leading indication of risk-significant events but is not itself risk-significant. The indicator measures the number of plant power changes for a typical year of operation at power.

**Indicator Definition**

The number of unplanned changes in reactor power greater than 20% of full-power, per 7,000 hours of critical operation excluding manual and automatic scrams.

**Data Reporting Elements**

The following data is reported for each reactor unit:

- the number of unplanned power changes, excluding scrams, during the



## FAQs - By Cornerstone/PI

### Initiating Events

#### IE03 – Unplanned Power Changes per 7,000 Critical Hours

Number	Cornerstone	PIs	Date Entered
--------	-------------	-----	--------------

previous quarter

- the number of hours of critical operation in the previous quarter

#### **Calculation**

The indicator is determined using the values reported for the previous 4 quarters as follows:

*value = ((total number of unplanned power changes over the previous 4 qtrs)/total number of hours critical during the previous 4 qtrs)\* 7,000 hrs*

#### **Definition of Terms**

*Unplanned change in reactor power*, for the purposes of this indicator, is a change in reactor power that (1) *was* initiated less than 72 hours following the discovery of an off-normal condition that required or *resulted* in a power change of greater than 20% full power to resolve and (2) has not been excluded *from* counting per the guidance below. Unplanned changes in reactor power also include uncontrolled excursions of greater than 20% of full power that occur in response to changes in reactor or plant conditions and are not an expected part of a planned evolution or test.

#### **Clarifying Notes**

The value of 7,000 hours is used because it represents one year of reactor operation at about an 80% availability factor.

If there are fewer than 2,400 critical hours in the previous four quarters the indicator value is displayed as N/A because rate indicators can produce misleadingly high values when the denominator is small. The data elements (unplanned power changes and critical hours) are still reported.

## FAQs - By Cornerstone/PI

### Initiating Events

#### IE03 – Unplanned Power Changes per 7,000 Critical Hours

Number	Cornerstone	PIs	Date Entered
--------	-------------	-----	--------------

The 72 hour period between discovery of an off-normal condition and the corresponding change in power level is based on the typical time to assess the plant condition, and prepare, review, and approve the necessary work orders, procedures, and necessary safety reviews, to effect a repair. The key element to be used in determining whether a power change should be counted as part of this indicator is the 72-hour period and not the extent of the planning that is performed between the discovery of the condition and initiation of the power change.

Given the above, it is incumbent upon licensees to provide objective evidence that identifies when the off-normal condition was discovered and when the power change of more than 20% was initiated. Such objective evidence may include logs, troubleshooting plans, meeting minutes, corrective action program documents, or similar type documentation.

Examples of occurrences that would be counted against this indicator include:

- Power reductions that exceed 20% of full power and are not part of a planned and documented evolution or test. Such power changes may include those conducted in response to equipment failures or personnel errors or those conducted to perform maintenance.
- Runbacks and power oscillations greater than 20 % of full power. A power oscillation that results in an unplanned power decrease of greater than 20% followed by an unplanned power increase of 20% should be counted as two separate PI events, unless the power restoration is implemented using approved procedures. For example, an operator mistakenly opens a breaker causing a recirculation flow decrease and a decrease in power of greater than 20%. The operator, hearing an alarm, suspects it was caused by his action and closes the breaker resulting in a power increase of greater than 20%. Both transients would count since they were the result of two separate errors (or unplanned/non-proceduralized action).

## FAQs - By Cornerstone/PI

### Initiating Events

#### IE03 – Unplanned Power Changes per 7,000 Critical Hours

Number	Cornerstone	PIs	Date Entered
--------	-------------	-----	--------------

- Unplanned downpowers of greater than 20% of full power for ALARA reasons

Examples of occurrences that are not counted include the following:

- Planned power reductions (anticipated and contingency) that exceed 20% of full power and are initiated in response to an off-normal condition discovered at least 72 hours before initiation of the power change.
- Unanticipated equipment problems that are encountered and repaired during a planned power reduction greater than 20% that alone could have required a power reduction of 20% or more to repair.
- Apparent power changes that are determined to be caused by instrument problems.
- If conditions arise that would normally require unit shutdown, and an NOED is granted that allows continued operation before power is reduced greater than 20%, an unplanned power change is not reported because no actual change in power greater than 20% of full power occurred. However, a comment should be made that the NRC had granted an NOED during the quarter, which, if not granted, may have resulted in an unplanned power change.
- Anticipatory power reductions intended to reduce the impact of external events such as hurricanes or range fires threatening offsite power transmission lines, and power changes requested by the steam load dispatches.
- Power changes to make rod pattern adjustments
- Power changes directed by the load dispatcher under normal operating conditions due to load demand, for economic reasons, for grid stability, or for nuclear plant safety concerns.

Anticipated power changes greater than 20% in response to expected environmental problems (such as accumulation of marine debris, biological contaminants, or frazil icing) which are proceduralized but cannot be predicted greater than 72 hours in

## FAQs - By Cornerstone/PI

### Initiating Events

#### IE03 – Unplanned Power Changes per 7,000 Critical Hours

Number	Cornerstone	PIs	Date Entered	
				<p>advance may not need to be counted unless they are reactive to the sudden discovery of off-normal conditions. However, unique environmental conditions which have not been previously experienced and could not have been anticipated and mitigated by procedure or plant modification, may not count, even if they are reactive. The licensee is expected to take reasonable steps to prevent intrusion of marine or other biological growth from causing power reductions. Intrusion events that can be anticipated as part of a maintenance activity or as part of a predictable cyclic behavior would normally be counted unless the down power was planned 72 hours in advance. The circumstances of each situation are different and should be identified to the NRC in a FAQ so that a determination can be made concerning whether the power change should be counted.</p> <p>Licensees should use the power indication that is used to control the plant to determine if a change of greater than 20% of full power has occurred.</p> <p>If a condition is identified that is slowly degrading and the licensee prepares plans to reduce power when the condition reaches a predefined limit, and 72 hours have elapsed since the condition was first identified, the power change does not count. If however, the condition suddenly degrades beyond the predefined limits and requires rapid response, this situation would count. If the licensee has previously identified a slowly degraded off-normal condition but has not prepared plans recognizing the potential need to reduce power when the condition reaches predefined limits, then a sudden degradation of that condition requiring rapid response would constitute a new off-normal condition and therefore, a new time of discovery.</p> <p>Off -normal conditions that begin with one or more power reductions and end with an unplanned reactor trip are counted in the unplanned reactor scram indicator only. However, if the cause of the downpower(s) and the scram are different, an unplanned power change and an unplanned scram must both be counted. For example, an unplanned power reduction is made to take the turbine generator off line while remaining critical to repair a component. However, when the generator is taken off line, vacuum drops rapidly due to a separate problem and a scram occurs. In this</p>

## FAQs - By Cornerstone/PI

### Initiating Events

#### IE03 – Unplanned Power Changes per 7,000 Critical Hours

Number	Cornerstone	PIs	Date Entered
--------	-------------	-----	--------------

case, both an unplanned power change and an unplanned scram would be counted. If an off-normal condition occurs above 20% power, and the plant is shutdown by a planned reactor trip using normal operating procedures, only an unplanned power change is counted.

FAQs - By Cornerstone/PI

Initiating Events

IE04 – Unplanned Scrams with Complications

Number	Cornerstone	PIs	Date Entered	
481	IE	IE04	9/21/2011	<b><u>Question</u></b>

**NEI 99-02 Guidance needing interpretation (include page and line citation):**

NEI 99-02 Revision 6, Page 20 lines 22 to 46, page 22 lines 35-45, and page 23 lines 1-10 discuss whether or not Main Feedwater was available following an unplanned scram.

**Event or circumstances requiring guidance interpretation:**

When FAQ #467 was approved, the response section stated that the guidance in NEI 99-02 should be reviewed to see if it needs to be revised based on circumstances that might require the availability of feedwater beyond 30 minutes and whether consideration of the scram response time window remains an appropriate marker for judging a complication to recovery from an unplanned scram.

The purpose of this FAQ is to define what constitutes scram “response” as opposed to scram “recovery.”

**If licensee and NRC resident/region do not agree on the facts and circumstances explain:**

In FAQ #467, the plant’s recommendation was to change the guidance in two locations:

1. If operating prior to the scram, did Main Feedwater cease to operate and was it unable to be restarted during the reactor scram response? The consideration for this question is whether Main Feedwater could be used to feed the reactor vessel if necessary. When considering the availability of Main Feedwater, it should be able to be restarted within the first 30 minutes following the scram.

The Senior Resident’s response was that this guidance change would not capture those events that are of higher safety significance because main feed is not available, even if it was not required to be used, and 30 minutes is a completely

## FAQs - By Cornerstone/PI

### Initiating Events

#### IE04 – Unplanned Scrams with Complications

Number	Cornerstone	PIs	Date Entered
--------	-------------	-----	--------------

arbitrary number.

2. Operations should be able to start a Main Feedwater pump and start feeding the reactor vessel with the Main Feedwater System within 30 minutes of the initial scram transient. During startup conditions where Main Feedwater was not placed in service prior to the scram, the question would not be considered, and should be skipped.

This Senior Resident's response to this proposed change was that even if the main feed steam supply is temporarily isolated, the PI should capture those events where main feed couldn't be restored in a relatively short time. It might be different if the equipment was designed such that restoration was not possible.

#### **Potentially relevant existing FAQ numbers:**

467

#### **Response**

##### **Proposed Resolution of FAQ:**

The following changes to NEI 99-02, Revision 6, are proposed to clarify (1) the period considered to be the scram response and (2) guidance pertaining to the availability of the main feedwater system in the scram response:

Page 18, lines 3 – 6:

This indicator monitors that subset of unplanned automatic and manual scrams that

## FAQs - By Cornerstone/PI

### Initiating Events

#### IE04 – Unplanned Scrams with Complications

Number	Cornerstone	PIs	Date Entered
--------	-------------	-----	--------------

either require additional operator actions beyond that of the normal scram or involve the unavailability of or inability to recover main feedwater. Such events or conditions have the potential to present additional challenges to the plant operations staff and therefore, may be more risk-significant than uncomplicated scrams.

Page 18, lines 9 – 12:

The USwC indicator is defined as the number of unplanned scrams while critical, both manual and automatic, during the previous 4 quarters that require additional operator actions or involve the unavailability of or inability to recover main feedwater as defined by the applicable flowchart (Figure 2) during the scram response (see definition of *scram response* in the Definitions of Terms section) and the associated flowchart questions.

Page 18, lines 17 – 18:

The number of unplanned automatic and manual scrams while critical in the previous quarter that required additional operator actions or involved the unavailability of or inability to recover main feedwater as determined by the flowchart criteria during the scram response.

Page 18, lines 24 – 26:

value = total unplanned scrams while critical in the previous 4 quarters that required additional operator actions or involved the unavailability of or inability to recover main feedwater as defined by the applicable flowchart and the associated flowchart questions (Figure 2) during the scram response.

Page 18, to be inserted at line 33 before the definition of *unplanned scram*:

*Normal Scram* means any scram that is not determined to be complicated in accordance with the guidance provided in the Unplanned Scrams with Complications indicator. A



## FAQs - By Cornerstone/PI

### Initiating Events

#### IE04 – Unplanned Scrams with Complications

Number	Cornerstone	PIs	Date Entered
--------	-------------	-----	--------------

normal scram is synonymous with an uncomplicated scram.

Page 18 or 19, to be inserted after the definition of *Criticality*:

*Scram Response* refers to the period of time that starts with the scram and concludes when operators have completed the scram response procedures and the plant has achieved a stabilized condition in accordance with approved plant procedures and as demonstrated by meeting the following criteria. For a PWR:

- Pressurizer pressure is within the normal operating pressure band.
- Pressurizer level is within the no-load pressurizer band.
- Level and pressure of all steam generators are within the normal operating bands.
- RCS temperature is within the allowable RCS no-load temperature band ( $T_{ave}$  if any RCS pump running,  $T_{cold}$  if no RCS pumps running).

For a BWR:

- No emergency operating procedure (EOP) entry conditions exist related to either the primary containment or the reactor.
- Reactor cool-down rates are less than 100 degrees F/hr.
- Reactor water level is being maintained within the range specified by plant procedures.

Page 20, lines 22 – 46:

#### **Was Main Feedwater unavailable or not recoverable using approved plant procedures during the scram response?**

If operating prior to the scram, did Main Feedwater cease to operate and was it unable to be restarted during the reactor scram response? The consideration for this question is whether Main Feedwater could be used to feed the steam generators if necessary. The qualifier of “not recoverable using approved plant procedures” will allow a licensee to

## FAQs - By Cornerstone/PI

### Initiating Events

#### IE04 – Unplanned Scrams with Complications

Number	Cornerstone	PIs	Date Entered
--------	-------------	-----	--------------

answer “No” to this question if there is no physical equipment restraint to prevent the operations staff from starting the necessary equipment, aligning the required systems, or satisfying required logic using plant procedures approved for use and in place prior to the reactor scram occurring.

The operations staff must be able to start and operate the required equipment using normal alignments and approved emergency, normal, and off-normal operating procedures to provide the required flow to the minimum number of steam generators required by the EOPs. Manual operation of controllers/equipment, even if normally automatic, is allowed if addressed by procedure. Situations that require maintenance or repair activities or non-proceduralized operating alignments require an answer of “Yes.” Additionally, the restoration of Feedwater must be capable of feeding the Steam Generators in a reasonable period of time. Operations should be able to start a Main Feedwater pump and start feeding Steam Generators with the Main Feedwater System within about 30 minutes from the time it was recognized that Main Feedwater was needed. During startup conditions where Main Feedwater was not placed in service prior to the scram this question would not be considered and should be skipped. For plants with design features or procedural prohibitions that prevent restarting Main Feedwater, this question should be answered as “No” if MFW is free from damage or failure that would prevent it from performing its intended function and is available for use.

Page 22, lines 35 – 45, and page 23, lines 1 – 10:

#### **Was Main Feedwater not available or not recoverable using approved plant procedures during the scram response?**

If operating prior to the scram, did Main Feedwater cease to operate and was it unable to be restarted during the reactor scram response? The consideration for this question is whether Main Feedwater could be used to feed the reactor vessel if necessary. The qualifier of “not recoverable using approved plant procedures” will allow a licensee to answer “NO” to this question if there is no physical equipment restraint to prevent the operations staff from starting the necessary equipment, aligning the required systems, or satisfying required logic circuitry using plant procedures approved for use that were in

## FAQs - By Cornerstone/PI

### Initiating Events

#### IE04 – Unplanned Scrams with Complications

Number	Cornerstone	PIs	Date Entered
--------	-------------	-----	--------------

place prior to the scram occurring.

The operations staff must be able to start and operate the required equipment using normal alignments and approved emergency, normal and off-normal operating procedures. Manual operation of controllers/equipment, even if normally automatic, is allowed if addressed by procedure. Situations that require maintenance or repair activities or non-proceduralized operating alignments will not satisfy this question. Additionally, the restoration of Main Feedwater must be capable of being restored to provide feedwater to the reactor vessel in a reasonable period of time. Operations should be able to start a Main Feedwater pump and start feeding the reactor vessel with the Main Feedwater System within about 30 minutes from the time it was recognized that Main Feedwater was needed. During startup conditions where main feedwater was not placed in service prior to the scram, this question would not be considered, and should be skipped.

Page H-1, lines 5 – 6:

The USwC PI will monitor the following six conditions that either have the potential to complicate the operators' scram response actions or involve the unavailability of or inability to recover main feedwater during the scram response.

Page H-4, lines 21 – 45, and page H-5, lines 1 – 34:

#### **H 1.5 Was Main Feedwater unavailable or not recoverable using approved plant procedures during the scram response?**

This section of the indicator is a holdover from the Scrams with Loss of Normal Heat Removal indicator which the USwC indicator replaced. Since all PWR designs have an emergency Feedwater system that operates if necessary, the availability of the normal or main Feedwater system, as a backup in emergency situations, can be important for managing risk following a reactor scram. This portion of the indicator is designed to assess that backup availability or ability to recover main feedwater as

## FAQs - By Cornerstone/PI

### Initiating Events

#### IE04 – Unplanned Scrams with Complications

Number	Cornerstone	PIs	Date Entered	
				<p>directed by approved plant procedures (e.g., the EOPs) on a loss of all emergency Feedwater.</p>
				<p>It is not necessary for the main Feedwater system to continue operating following a reactor trip. Some plants, by design, have certain features to prevent main feedwater from continued operation or from allowing it to be restarted unless certain criteria are met. Since some plant designs do not include electric driven main Feedwater pumps (steam driven pumps only) it may not be possible to restart main Feedwater pumps without a critical reactor. Additionally, some other plant designs have interlocks and signals in place to prevent feeding the steam generators with main Feedwater unless reactor coolant temperature is greater than the no-load average temperature. In both cases, these plants may be justified in answering this question as “No” if MFW is free from damage or failure that can prevent it from performing its intended function and is available for use.</p>
				<p>Licensees should rely on the material condition availability of the equipment to reach the decision for this question. Condenser vacuum, cooling water, and steam pressure values should be evaluated based on the requirements to operate the pumps and may be lower than normal if procedures allow pump operation at that lower value. As long as these support systems are able to be restarted (if not running) to support main feedwater restart within the estimated 30 minute timeframe they can be considered as available. These requirements apply until the completion or exit of the scram response.</p>
				<p>The availability of steam dumps to the condenser does NOT enter into this indicator at all. Use of atmospheric steam dumps following the reactor trip is acceptable for any duration.</p>
				<p>Loss of one feed pump does not cause a loss of main feedwater. Only one is needed to remove residual heat after a trip. As long as at least one pump can still operate and provide Feedwater to the minimum number of steam generators required by the EOPs to satisfy the heat sink criteria, main feedwater should be</p>

## FAQs - By Cornerstone/PI

### Initiating Events

#### IE04 – Unplanned Scrams with Complications

Number	Cornerstone	PIs	Date Entered
--------	-------------	-----	--------------

considered available.

The failure in a closed position of a feedwater isolation valve to a steam generator is a loss of feed to that one steam generator. As long as the main feedwater system is able to feed the minimum number of steam generators required by the EOPs to satisfy the heat sink criteria, the loss of ability to feed other steam generators should not be considered a loss of feedwater. Isolation of the feedwater regulating or isolation valves does not constitute a loss of feedwater if nothing prevents them from being reopened in accordance with procedures.

A Steam Generator Isolation Signal or Feedwater Isolation Signal does not constitute a loss of main feedwater as long as it can be cleared and feedwater restarted. If the isolation signal was caused by a high steam generator level, the 30-minute estimate for restart timeframe should start once the high level isolation signal has cleared.

The estimated 30-minute timeframe for restart of main Feedwater was chosen based on restarting from a hot and filled condition. Since this time frame will not be measured directly, it should be an estimation developed based on the material condition of the plant's systems following the reactor trip. If no abnormal material conditions exist, the 30 minutes should be met. If plant procedures and design would require more than 30 minutes, even if all systems were hot and the material condition of the plant's systems following the reactor trip were normal, that routine time should be used in the evaluation of this question, provided SG dry-out cannot occur on an uncomplicated trip if the time is longer than 30 minutes. The judgment of the on-shift licensed SRO during the reactor trip should be used in determining if this timeframe was met.

Page H-19, lines 41 – 46, and page H-20, lines 1 – 16:

**H 3.5 Was Main Feedwater not available or not recoverable using approved plant procedures during the scram response?**

## FAQs - By Cornerstone/PI

### Initiating Events

#### IE04 – Unplanned Scrams with Complications

Number	Cornerstone	PIs	Date Entered
--------	-------------	-----	--------------

If operating prior to the scram, did Main Feedwater cease to operate and was it unable to be restarted during the reactor scram response? The consideration for this question is whether Main Feedwater could be used to feed the reactor vessel if necessary. The qualifier of “not recoverable using approved plant procedures” will allow a licensee to answer “NO” to this question if there is no physical equipment restraint to prevent the operations staff from starting the necessary equipment, aligning the required systems, or satisfying required logic circuitry using plant procedures approved for use that were in place prior to the scram occurring.

The operations staff must be able to start and operate the required equipment using normal alignments and approved emergency, normal and off-normal operating procedures. Manual operation of controllers/equipment, even if normally automatic, is allowed if addressed by procedure. Situations that require maintenance or repair activities or non-proceduralized operating alignments will not satisfy this question. Additionally, the restoration of Main Feedwater must be capable of being restored to provide feedwater to the reactor vessel in a reasonable period of time. Operations should be able to start a Main Feedwater pump and start feeding the reactor vessel with the Main Feedwater System within about 30 minutes from the time it was recognized that Main Feedwater was needed. During startup conditions where Main Feedwater was not placed in service prior to the scram, this question would not be considered, and should be skipped.

Page H-20, lines 18 – 46, and page H-21, lines 1 – 7:

#### **H 3.6 Following initial transient, did stabilization of reactor pressure/level and drywell pressure meet the entry conditions for EOPs?**

Since BWR designs have an emergency high pressure system that operates automatically between a vessel-high and vessel-low level, it is not necessary for the Main Feedwater System to continue operating following a reactor trip. However, failure of the Main Feedwater System to be available is considered to be risk

## FAQs - By Cornerstone/PI

### Initiating Events

#### IE04 – Unplanned Scrams with Complications

Number	Cornerstone	PIs	Date Entered	
				<p>significant enough to require a “Yes” response for this PI. To be considered available, the system must be free from damage or failure that would prohibit restart of the system. Therefore, there is some reliance on the material condition or availability of the equipment to reach the decision for this question. Condenser vacuum, cooling water, and steam pressure values should be evaluated based on the requirements to operate the pumps and may be lower than normal if procedures allow pump operation at that lower value.</p>
				<p>The estimated 30 minute timeframe for restart of Main Feedwater was chosen based on restarting from a hot condition with adequate reactor water level. Since this timeframe will not be measured directly, it should be an estimation developed based on the material condition of the plants systems following the reactor trip. If no abnormal material conditions exist, the 30 minutes should be capable of being met. If plant procedures and design would require more than 30 minutes, even if all systems were hot and the material condition of the systems following the reactor trip were normal, a routine time should be used in the evaluation of this question. The judgment of an on-shift licensed SRO should be used in determining if this timeframe is met.</p>
				<p>When a scram occurs plant operators will enter the EOPs to respond to the condition. In the case of a routine scram the procedure entered will be exited fairly rapidly after verifying that the reactor is shutdown, excessive cooling is not in progress, electric power is available, and reactor coolant pressures and temperatures are at expected values and controlled. Once these verifications are done and the plant conditions considered “stable” (see guidance in the Definition of Terms section under <i>scram response</i>) operators will exit the initial procedure to another procedure that will stabilize and prepare the remainder of the plant for transition for the use of normal operating procedures. The plant would then be ready be maintained in Hot Standby, to perform a controlled normal cool down, or to begin the restart process. The criteria in this question is used to verify that there were no other conditions that developed during the stabilization of the plant in the scram response related vessel parameters that required continued operation in the EOPs or re-entry into the EOPs or transition to a follow-on EOP. Maintaining operation in EOPs that are not related</p>

FAQs - By Cornerstone/PI

Initiating Events  
IE04 – Unplanned Scrams with Complications

Number	Cornerstone	PIs	Date Entered	
--------	-------------	-----	--------------	--

to vessel and drywell parameters do not count in this PI.

NRC Response:

NRC staff agrees with the proposed resolution and an effective date of October 1, 2011, meaning that the FAQ resolution will begin to be applied to 4Q2011 data that will be reported in January 2012.

478            IE            IE04            2/16/2011

**Question**

**NEI 99-02 Guidance needing interpretation (include page and line citation):**

NEI 99-02, Revision 6, Page 20, Lines 22 – 42  
NEI 99-02, Revision 6, Appendix H, Section 1.5

**Event or circumstances requiring guidance interpretation:**

Background

A. Event

At approximately 0013 hours on October 7, 2010, an automatic trip occurred at H. B. Robinson Steam Electric Plant (HBRSEP), Unit No. 2. An electrical fault on the motor for Reactor Coolant Pump (RCP) 'C' resulted in the Single Loop Low Flow reactor protection function and a subsequent reactor trip. Following the trip, the Auxiliary Feedwater system automatically actuated due to low steam generator water level and provided feedwater to the steam generators. Main Feedwater (MFW) Pump 'B' tripped on low suction flow. The trip of Reactor Coolant Pump 'C' resulted in pressure in Steam Generator 'C' being below the pressure in the other two steam generators. This caused Auxiliary Feedwater (AFW) flow predominantly to Steam Generator 'C.' Level continued to rise until Main Feed Pump 'A' tripped,



FAQs - By Cornerstone/PI

Initiating Events

IE04 – Unplanned Scrams with Complications

Number	Cornerstone	PIs	Date Entered
--------	-------------	-----	--------------

as designed, due to a Feedwater Isolation Signal (FWIS).

At approximately 0405 hours, during post-trip recovery actions about four hours after the trip, the AFW system actuated due to a trip of MFW Pump 'A' while attempting to restore MFW by starting MFW Pump 'A' in accordance with procedure GP-004, "Post Trip Stabilization." The reason for the MFW Pump 'A' trip was that the FWIS was still active. The AFW system actuation signal caused motor-driven AFW Pump 'B' to start, motor-driven AFW Pump 'A' was already in operation due to the post-trip condition. The AFW system was adequately handling SG levels and MFW was not required at the time.

At approximately 1018 hours, feedwater isolation key switches were placed and maintained in the Override/Reset position by the operations staff in order to restore MFW by starting MFW Pump 'A.' Placing the key switches in the Override/Reset position resulted in the disabling of the feedwater isolation function at the same time the feedwater regulating bypass valves were open.

At approximately 1315 hours, following approximately three hours of effective MFW operation, the operations staff recognized that actions taken at 1018 hours had unknowingly placed the plant in a condition prohibited by the Technical Specifications and took the appropriate action to close the MFW regulating bypass valves at approximately 1329 hours.

B. Timeline for October 7, 2010, Plant Trip

Time	Description
0013	Automatic reactor trip due to an electrical fault on the RCP 'C' motor. MFW Pump 'B' tripped. AFW system in operation.
0024	MFW Pump 'A' trips on high SG 'C' level.
0104	AFW Pump 'B' secured. AFW Pump 'A' running to support SG levels.

## FAQs - By Cornerstone/PI

### Initiating Events IE04 – Unplanned Scrams with Complications

Number	Cornerstone	PIs	Date Entered	
0203				Exited scram EOP and entered GP-004.
0405				AFW system actuated due to a trip of MFW Pump 'A' while attempting to restore MFW by starting MFW Pump 'A.' The AFW system actuation signal caused motor-driven AFW Pump 'B' to start, motor-driven AFW Pump 'A' was already in operation.
0409				Walkdown of MFW Pump 'A' completed with no abnormalities noted. Trip of MFW Pump 'A' had occurred due to the FWIS still present at the time of the start attempt.
1018				Feedwater isolation key switches were placed and maintained in the Override/Reset position by the operations staff in order to restore MFW by starting MFW Pump 'A.'
1020				AFW Pump 'A' secured.
1329				Closed MFW regulating bypass valves. SG levels maintained using AFW pumps.

#### C. Plant Design

To reset the FWIS for a Steam Generator (and allow restoration of MFW), the initiating signal(s) (e.g., Hi-Hi Steam Generator level) must be cleared, the Reactor Trip Breakers must be closed, and the feedwater isolation signal must be reset by momentarily placing the key switch in the Reset/Override position and then returning the key switch to the Normal position. These actions are provided in OP-403, "Feedwater System," Section 8.4.4. The guidance to override the FWIS to restore MFW is included in emergency procedure FRP-H.1, "Response to Loss of Secondary Heat Sink."

#### D. Applicable Procedures

GP-004, "Post Trip Stabilization," provides instruction for stabilizing conditions and shutting down components following a plant trip.

## FAQs - By Cornerstone/PI

### Initiating Events

#### IE04 – Unplanned Scrams with Complications

Number	Cornerstone	PIs	Date Entered	
				<p data-bbox="919 337 1896 472">OP-403, “Feedwater System,” includes instructions for startup and infrequent operation of the Feedwater System, including instructions for restoration of feedwater after a plant trip. Actions to reset the FWIS for a Steam Generator (and allow restoration of MFW) are provided in Section 8.4.4.</p> <p data-bbox="919 516 1854 651">Emergency procedure FRP-H.1, “Response to Loss of Secondary Heat Sink,” includes actions to respond to a loss of secondary heat sink in all Steam Generators, including instructions for overriding the Feedwater Isolation Signal (FWIS) to restore MFW (Step 16).</p> <p data-bbox="873 695 1283 719">E. <u>Applicable NEI 99-02 Guidance</u></p> <p data-bbox="919 764 1520 789">From NEI 99-02, Revision 6, Page 20, Lines 22 – 42:</p> <p data-bbox="968 833 1843 898">Was Main Feedwater unavailable or not recoverable using approved plant procedures following the scram? (Lines 22-24)</p> <p data-bbox="968 954 1885 1089">If operating prior to the scram, did Main Feedwater cease to operate and was it unable to be restarted during the reactor scram response? The consideration for this question is whether Main Feedwater could be used to feed the steam generators if necessary. (Lines 25-27)</p> <p data-bbox="968 1146 1902 1349">The qualifier of “not recoverable using approved plant procedures” will allow a licensee to answer “No” to this question if there is no physical equipment restraint to prevent the operations staff from starting the necessary equipment, aligning the required systems, or satisfying required logic using plant procedures approved for use and in place prior to the reactor scram occurring. (Lines 27-32)</p> <p data-bbox="968 1406 1902 1471">The operations staff must be able to start and operate the required equipment using normal alignments and approved normal and off-normal operating</p>

## FAQs - By Cornerstone/PI

### Initiating Events

#### IE04 – Unplanned Scrams with Complications

Number	Cornerstone	PIs	Date Entered
--------	-------------	-----	--------------

procedures to feed the minimum number of steam generators required by the EOPs to satisfy the heat sink criteria. (Lines 34-37)

Additionally, the restoration of Feedwater must be capable of feeding the Steam Generators in a reasonable period of time. Operations should be able to start a Main Feedwater pump and start feeding the Steam Generators with the Main Feedwater System within 30 minutes. (Lines 39-42)

#### F. Event Root Cause Evaluation

Root Cause Evaluation 425643 investigated the reasons that the operating crew was unable to reset the FWIS and restore the feed water supply from the MFW pumps on their first attempt. This investigation found that GP-004 was inadequate in that it did not provide appropriate guidance for resetting the Feed Water Isolation Signal (FWIS). Knowledge deficiency for Operators regarding the method for properly resetting the Feedwater Isolation Logic was also identified as a contributing cause.

#### Analysis

The NEI 99-02 guidance provided in Item E above can be broken down into six questions:

#### 1) *Could Main Feedwater be used to feed the steam generators if necessary?*

Yes. As stated in NEI 99-02, Appendix H, "Licensees should rely on the material condition availability of the equipment to reach the decision for this question." The MFW system was free of damage or failure that would prevent restart of the system to feed the steam generators if there was a loss of all AFW.

In fact, as noted in Question 2 below, MFW Pump 'A' was started and operated

## FAQs - By Cornerstone/PI

### Initiating Events

#### IE04 – Unplanned Scrams with Complications

Number	Cornerstone	PIs	Date Entered	
				<p>effectively on the day of and day following the scram and operated effectively without the need for any maintenance.</p>
				<p>2) Was there a physical equipment restraint that prevented the operations staff from recovering Main Feedwater by starting the necessary equipment, aligning the required systems, or satisfying required logic using existing plant procedures?&gt;</p>
				<p>No. The MFW system material condition was in a state of readiness for startup and operation via MFW Pump 'A' and Feedwater regulating bypass valves. MFW Pump 'A' was started by the operations staff at 1018 hours on the day of the trip and at 0201 hours on the day after the trip. In both cases, MFW operated effectively without the need for any maintenance.</p>
				<p>Throughout the event, the MFW system was available and recoverable using existing plant procedures. The event investigation concluded that GP-004, Post Trip Stabilization, did not provide sufficiently detailed guidance to ensure the FWIS was effectively reset given plant conditions at 0405 hours on the day of the trip. Normal operating procedure OP-403 did provide appropriate and sufficiently detailed guidance to effectively reset the FWIS, had the operations staff referred to the procedure at the time.</p>
				<p>NEI 99-02 states that isolation of the feedwater regulating or isolation valves does not constitute a loss of feedwater if nothing prevents them from being reopened in accordance with procedures. Also, a Steam Generator Isolation Signal or FWIS does not constitute a loss of MFW as long as it can be cleared and feedwater restarted. (See NEI 99-02, Appendix H, Page H-5.)</p>
				<p>In addition, NEI 99-02, Appendix H, Section H 1.5 states that "this portion of the indicator is designed to measure that backup availability [of MFW] directed by EOPs on a loss of all emergency Feedwater." Emergency response procedure FRP-H.1 provided sufficient guidance to override the FWIS, if necessary, so that MFW could be restored if there was a loss of all AFW and MFW was required. Had</p>

## FAQs - By Cornerstone/PI

### Initiating Events

#### IE04 – Unplanned Scrams with Complications

Number	Cornerstone	PIs	Date Entered	
				emergency response procedure FRP-H.1 use been required during the event due to a loss of all AFW, this trip would have been considered an Unplanned Scram with Complications.
				3) <i>Were plant procedures for recovering Main Feedwater approved for use and in place prior to the reactor scram occurring?</i>
				Yes. Procedure OP-403 was available and approved for use prior to the plant trip. Also, procedure FRP-H.1 was available and approved for use prior to the plant trip. Had emergency response procedure FRP-H.1 use been required during the event due to a loss of all AFW, this trip would have been considered an Unplanned Scram with Complications.
				4) <i>Was the operations staff able to start and operate the required equipment using normal alignments and approved normal and off-normal operating procedures?</i>
				Yes. As noted earlier, while GP-004 did not provide sufficiently detailed guidance to ensure the FWIS was effectively reset given plant conditions at 0405 hours on October 7, 2010, normal operating procedure, OP-403, "Feedwater System," provided appropriate and sufficiently detailed guidance to effectively reset the FWIS, but the operators did not refer to this procedure at the time.
				It is important to note that the system was capable of being started and operated using normal alignments and approved normal and off-normal operating procedures. As stated in NEI 99-02, Appendix H:
				"This section of the indicator is a holdover from the Scrams with Loss of Normal Heat Removal indicator which the USwC indicator is replacing. Since all PWR designs have an emergency Feedwater system that operates if necessary, the availability of the normal or main Feedwater systems is a backup in emergency situations. This portion of the indicator is designed to measure that backup availability directed by the EOPs on a loss of all

## FAQs - By Cornerstone/PI

### Initiating Events

#### IE04 – Unplanned Scrams with Complications

Number	Cornerstone	PIs	Date Entered
--------	-------------	-----	--------------

emergency Feedwater.”

This implies that the indicator is not intended as a measure of operations staff performance. For this event, Operations staff performance was evaluated and factored into the Reactor Oversight Process via NRC inspection activities. The operations staff actions during this event were identified as part of a Green Non-Cited Violation in NRC Inspection Report 05000261/2010012. The report states, “Contrary to procedure OP-403, Feedwater System, control room operators overrode the feedwater isolation safety function by placing the feedwater logic switches in ‘Override/Reset,’ and leaving them in that position for three hours and twenty minutes.”

- 5) *Were the operations staff able to start and operate the required equipment using normal alignments and approved normal and off-normal operating procedures to feed the minimum number of steam generators required by the EOPs to satisfy the heat sink criteria?*

Yes. As noted above, while GP-004 did not provide sufficiently detailed guidance to ensure the FWIS was effectively reset given plant conditions at 0405 hours on October 7, 2010, normal operating procedure OP-403 provided appropriate and sufficiently detailed guidance to effectively reset the FWIS, but the operators did not refer to this procedure at the time.

- 6) *Were the operations staff able to start a Main Feedwater pump and start feeding the Steam Generators with the Main Feedwater System within 30 minutes?*

Design features and procedural requirements at HBRSEP, Unit No.2, can delay normal resetting of the FWIS during non-emergency conditions such that it may take much longer than 30 minutes to restore MFW. Following an uncomplicated trip, the following steps must be completed prior to resetting the FWIS and restoring MFW:

## FAQs - By Cornerstone/PI

### Initiating Events

#### IE04 – Unplanned Scrams with Complications

Number	Cornerstone	PIs	Date Entered
--------	-------------	-----	--------------

1. Ensuring that Steam Generator levels are less than 75%
2. Ensure the Reactor Trip Breakers are Closed or Close them as follows:
  - a. Determine if applicable surveillances tests are within their required periodicity.
  - b. If not, perform the necessary surveillance tests.
  - c. Close the Reactor Trip Breakers.
3. Reset the FWIS on the appropriate Steam Generator(s), by momentarily placing the key switch(es) for the applicable Steam Generator(s) in the Override/Reset position and returning the switch(es) to the Normal position.

Had there been a loss of all AFW that would have required a more immediate restoration of MFW, emergency response procedure FRP-H.1 provided sufficient guidance to override the FWIS, so that MFW could be restored. Had emergency response procedure FRP-H.1 use been required during the event due to a loss of all AFW, this trip would have been considered an Unplanned Scram with Complications.

#### Conclusion

Based on the above, HBRSEP, Unit No. 2, concludes that it is appropriate to answer “No” to the question: “Was Main Feedwater unavailable or not recoverable using approved plant procedures following the scram?”

**If licensee and NRC resident/region do not agree on the facts and circumstances explain**

#### Licensee Conclusion

As stated above, HBRSEP, Unit No. 2, has determined that the answer to the question “Was Main Feedwater unavailable or not recoverable using approved plant procedures following the scram?” is “No,” based on the guidance provided in NEI 99-02, Revision 6,



## FAQs - By Cornerstone/PI

### Initiating Events

#### IE04 – Unplanned Scrams with Complications

Number	Cornerstone	PIs	Date Entered
--------	-------------	-----	--------------

Page 20, Lines 22 -42.

#### NRC Resident Inspector Perspective

The Resident Inspector disagrees with the licensee’s conclusion that it is appropriate to answer “No” to the question: “Was Main Feedwater unavailable or not recoverable using approved plant procedures following the scram?”

From NEI 99-02, Revision 6, Page 20, Lines 34-37:

*The operations staff must be able to start and operate the required equipment using normal alignments and approved normal and off-normal operating procedures to feed the minimum number of steam generators required by the EOPs to satisfy the heat sink criteria.*

The resident inspector position is that the licensee’s operators were not able to start and operate the required equipment using normal alignments and approved normal and off-normal operating procedures to feed the minimum number of steam generators required by the EOPs to satisfy the heat sink criteria. This position is supported by the actual sequence of events which included an unsuccessful attempt to reset the Feedwater Isolation signal and later defeating the Technical Specification required Feedwater Isolation signal. As described in the licensee’s timeline, the restoration of Main Feedwater was untimely in that the scram recovery demonstrated the staff was not able to start and operate the required equipment using approved normal operating procedure, GP-004, “Post Trip Stabilization.”

The licensee noted that 4 hours after the scram the night shift control room crew attempted to reset the Feedwater Isolation signal and restore Main Feedwater. The licensee identified 6 hours later that the day shift control room crew had restored Main Feedwater by overriding the active Feedwater Isolation signal and defeating a Technical Specification required safety function. This action was performed independent of the night shift and with the support of a fully staffed Outage Command

## FAQs - By Cornerstone/PI

### Initiating Events

#### IE04 – Unplanned Scrams with Complications

Number	Cornerstone	PIs	Date Entered	
				<p>Center, including representatives from Engineering, Operations, Maintenance and Work Controls. The failure to successfully reset the feedwater isolation signal and start and operate the required equipment using normal alignments and approved normal operating procedure, in this case GP-004, "Post Trip Stabilization," complicated the scram response.</p> <p>From NEI 99-02, Revision 6, Page 20, Lines 39-42:</p> <p><i>Additionally, the restoration of Feedwater must be capable of feeding the Steam Generators in a reasonable period of time. Operations should be able to start a Main Feedwater pump and start feeding the Steam Generators with the Main Feedwater System within 30 minutes.</i></p> <p>The sequence of events did not demonstrate a timely restoration of Main Feedwater. The plant specific design features which must be accounted for, specifically the pre-requisites for closing the reactor trip breakers were accomplished within 1 hour once started. Taking into consideration that the plant was stable and the operating crew was progressing in a deliberate manner, the resident inspectors' concluded that the length of time to restore Main Feedwater was excessive from both the time to reset the reactor trip breakers and coordination with the operating crews.</p> <p>The Resident Inspectors' concluded is that it is appropriate to answer "Yes" to was Main Feedwater unavailable or not recoverable using normal alignments and an approved normal operating procedure following the scram. As provided in the NEI guidance document, the re-establishment of Main Feedwater following an uncomplicated scram must be accomplished using normal alignments and approved normal operating approved procedures. In this instance the operators were not successful in reestablishing Main Feedwater although they were following the appropriate approved procedure.</p> <p><b>Potentially relevant existing FAQ numbers</b></p>

## FAQs - By Cornerstone/PI

### Initiating Events

#### IE04 – Unplanned Scrams with Complications

Number	Cornerstone	PIs	Date Entered
--------	-------------	-----	--------------

FAQ 474

#### **Response**

##### **Proposed Resolution of FAQ**

Based on the fact that Main Feedwater was free from damage or failure that would prevent restart of the system to feed the steam generators if there was a loss of all AFW, that the MFW system was always available to be restarted, that the plant was no longer in scram response but in scram recovery, and approved procedures were in place for recovering MFW if needed, this event does not count as an Unplanned Scrams with Complications. Such a resolution is consistent with NEI 99-02, including Appendix H, which clearly states that this portion of the indicator is designed to measure the backup availability of MFW directed by the EOPs on a loss of all AFW.

It is also consistent with the precedence set by the NRC in FAQ 474. The NRC Senior Resident Inspector position was:

“However, if procedure EMG FR H1 was used on April 28, 2009, the main feedwater portion of the procedure would not have been successful because all three main feedwater pumps required maintenance (speed switch, servo valve, and a circuit breaker). Consistent with page 19 of NEI 99-02, Revision 6 and page H-4, lines 24 to 29, the PI monitors the ability of main feedwater to be used to feed the steam generators if necessary in emergency operating procedures. On April 28, 2009, Wolf Creek did not have the ability to restore and use main feedwater in normal or emergency operating procedures because all three main feedwater pumps needed maintenance, and not because of isolation signals.”

The basis for the NRR final position that FAQ 474 was a complicated scram was:

“Any active design features (e.g., interlocks or signals that isolate MFW after a reactor trip) used as the basis in answering No to the question “Is MFW

FAQs - By Cornerstone/PI

Initiating Events

IE04 – Unplanned Scrams with Complications

Number	Cornerstone	PIs	Date Entered
--------	-------------	-----	--------------

Unavailable?" is applicable only if the MFW system is free from damage and does not need repair or maintenance (i.e., the MFW system is capable of performing its intended function if called upon)."

Because the Robinson MFW system was free from damage and the plant would have been able to restore and use MFW in an emergency operating procedure, this is not an Unplanned Scram with Complications.

**If appropriate, provide proposed rewording of guidance for inclusion in next revision.**

N/A

NRC Response to FAQ:

The scram at H. B. Robinson on October 7th, 2010 is not an unplanned scram with complications. However, it was noted during discussions between the NRC and industry that if the Emergency procedure FRP-H.1, "Response to Loss of Secondary Heat Sink," did not provide sufficient guidance for operators to restore MFW, then this scram would have been considered complicated.

## FAQs - By Cornerstone/PI

### Initiating Events

#### IE04 – Unplanned Scrams with Complications

Number	Cornerstone	PIs	Date Entered	
475	IE	IE04	9/23/2010	<p><b><u>Question</u></b> <b>NEI 99-02 Guidance needing interpretation (include page and line citation):</b></p> <p>IE04 page 21 Lines 2 -10: “Was the scram response procedure unable to be completed without entering another EOP?”</p> <p>Appendix H2.3 PWR Case Study 3, page H-14 Line 9 through H-17 line 23: This case study discusses a PWR event with loss of forced circulation and entry into natural circulation that was answered “NO” for question six regarding entry into EOPs.</p> <p>The IE04 guidance currently excludes counting loss of forced circulation (LOFC) under the Westinghouse ES01 Emergency Operating Procedure (EOP) scheme, but requires counting the same scenario under the Combustion Engineering CEN-152 EOP scheme. The proposed resolution would add an Appendix D FAQ to also exclude counting LOFC events under the Combustion Engineering CEN-152 EOP scheme.</p> <p>The Westinghouse exclusion is based on normal scram recovery and restoration of forced circulation being addressed within the single Westinghouse ES01 EOP. Transition to another EOP is not required. For the same LOFC event, the CEN-152 EOP scheme organizes the response into two EOPs, the normal scram and LOFC.</p> <p>The administrative arrangement of Westinghouse ES01 for a LOFC without a cooldown using natural circulation provides no safety benefit over the arrangement of CEN-152.</p> <p>Without any other complications, an LOFC event does not require counting as an unplanned scram with complications in the ES01 scheme and it should not count in the CEN-152 scheme.</p>

**Event or circumstances requiring guidance interpretation:**

On December 3, 2009, Palo Verde Unit 3 experienced a loss of containment instrument

## FAQs - By Cornerstone/PI

### Initiating Events

#### IE04 – Unplanned Scrams with Complications

Number	Cornerstone	PIs	Date Entered	
				<p>air that resulted in an eventual loss of normal reactor coolant pump (RCP) seal bleed-off flow. This caused the seal bleed-off relief valve to lift to send bleed-off to the reactor drain tank (RDT). To prevent overflow of the RDT and a breach of the RDT rupture disk, control room staff elected to scram the reactor and secure all four RCPs. After completing the standard post-trip actions (SPTAs), the plant remained in mode 3 via natural circulation until forced circulation was restored after instrument air was restored in containment. A cooldown using natural circulation was NOT initiated. The safety functions were met. All rods fully inserted, the turbine tripped automatically upon scrambling the reactor, class and non-class AC busses remained energized, no safety injection occurred, and main feedwater remained in service or available throughout the event. During the event, charging remained available through the pressurizer auxiliary spray line. Letdown and the ability to pump down the RDT were lost because the respective air-operated containment isolation valves shut upon loss of instrument air pressure. These losses were addressed by the use of abnormal operating procedures that do not require entry into another EOP. A contingency action from EOP standard appendices was used to manually align turbine gland seal steam. The RDT rupture disk remained intact, and the each of the RCPs' 3-stage seals operated per design without experiencing abnormal leak-off or heating.</p> <p>To address the event after diagnosing the loss of instrument air inside containment, the control room staff entered the SPTA EOP. The RCPs were secured and the LOFC EOP was entered to control the plant using natural circulation until forced circulation was restored.</p> <p><b>If licensee and NRC resident/region do not agree on the facts and circumstances explain</b></p> <p>The NRC resident and Palo Verde are in agreement on the facts of the event and the content of NEI guidance. Both agree that after the reactor trip and manual shutdown of the RCPs, the station entered a second EOP (the LOFC EOP) to maintain heat removal via natural circulation until instrument air and forced circulation were restored.</p>

## FAQs - By Cornerstone/PI

### Initiating Events

#### IE04 – Unplanned Scrams with Complications

Number	Cornerstone	PIs	Date Entered
--------	-------------	-----	--------------

The NRC resident and Palo Verde differ on whether the guidance provided in NEI 99-02 regarding the Westinghouse ES01 EOP scheme provides an adequate basis for a plant specific exemption that would permit a “No” answer for the question whether the scram procedure was able to be completed without entering another EOP. The NRC resident’s contention is based on the purpose of the performance indicator, which is track performance related to “events or conditions that may have the potential to present additional challenges to the plant operations staff and therefore, may be more risk-significant than uncomplicated scrams” given the challenges the Operations staff faced during the December 3, 2009, Unit 3 loss of instrument air event.

#### **Potentially relevant existing FAQ numbers**

There are no relevant existing FAQs

#### **Response**

##### **Proposed Resolution of FAQ**

Enter a Combustion Engineering NSSS vendor specific FAQ into Appendix D of NEI 99-02 that would permit a “NO” answer in response to the question “Was the scram response procedure unable to be completed without entering another EOP?” for specific scram events that require entry into the Loss of Forced Circulation EOP. This exception would not apply to LOFC events that were initiated by a loss of offsite power or resulted in a plant cooldown using natural circulation.

To align the December 3, 2009, Palo Verde scram with the indicator as described in the IE04 guidance for Westinghouse design and EOPs, approval of this FAQ would allow the event to be counted only as an unplanned scram.

#### **If appropriate, provide proposed rewording of guidance for inclusion in next revision.**

Not applicable – Appendix D FAQ

*NRC Response to FAQ:*

## FAQs - By Cornerstone/PI

### Initiating Events

#### IE04 – Unplanned Scrams with Complications

Number	Cornerstone	PIs	Date Entered
--------	-------------	-----	--------------

The December 3, 2009 scram will be counted as an unplanned scram with complications.

The guidance in NEI 99-02 clearly indicates that if more than one EOP is entered following a scram, then the unplanned scram is considered complicated. Since reactor designs and associated EOP structures are different, it is recommended that the inquiries in this FAQ be explored in a generic FAQ.



## FAQs - By Cornerstone/PI

### Initiating Events

#### IE04 – Unplanned Scrams with Complications

Number	Cornerstone	PIs	Date Entered	
474	IE	IE04	6/21/2010	<u>Question</u>

#### NEI 99-02 Guidance needing interpretation:

Page 19, “Was Main Feedwater unavailable or not recoverable using approved plant procedures following the scram.” Attachment H, Page H-4, Lines 36 through 39, “Some other designs have interlocks in place to prevent feeding the steam generators with main Feedwater unless reactor coolant temperature is greater than the no-load average temperature. These plants should also answer this question as “No” and move on.”

#### Event or Circumstances requiring guidance interpretation:

On April 28, 2009, WCGS experienced a reactor trip (scram)/turbine trip due to ‘B’ Steam Generator (SG) lolo water level caused by a main feedwater regulating valve (MFRV) controller failure. All equipment functioned as required. Steam generator water level control during and immediately after the scram was not an issue and the plant responded as expected. As designed, both Steam Driven Main Feedwater Pumps tripped on the feedwater isolation signal and steam generator water levels were restored and maintained by auxiliary feedwater flow. RCS temperature stabilized below 560°F and remained there. All required systems for a non-complicated scram functioned as required. Normal plant trip procedures were used and then normal plant recovery procedures were entered. Both the plant design and the approved EOPs do not allow for restart of the main feedwater pumps during a normal plant trip for WCGS.

Prior to the trip, the Main Feedwater Pumps were operating normally, and subsequently tripped per design on the expected Feedwater isolation signal. At the time of the trip, there was no indication that the main feedwater pumps would not have functioned. Several days later, during preparations for restart and return of the plant to power, both Steam Driven Main Feedwater Pumps and the Startup Feed pump required maintenance assistance to return them to service. The event was reported in

## FAQs - By Cornerstone/PI

### Initiating Events

#### IE04 – Unplanned Scrams with Complications

Number	Cornerstone	PIs	Date Entered
--------	-------------	-----	--------------

the monthly performance indicator IE01 as an Unplanned Scram per 7000 Hours.

On a normal scram from power, WCGS expects to receive a feedwater isolation signal on low Tavg coincident with P-4 and a LoLo SG level Feedwater Isolation signal. If main feedwater does not isolate following a scram, manual isolation of feedwater is directed in the scram response procedures. The logic for main feedwater isolation on low Tavg coincident with P-4 can be reset any time after the signal is received, however the SG LoLo water level isolation signal cannot be cleared until the SG LoLo water level condition is cleared. This prevents feeding with the main feedwater pumps and adding positive reactivity via cooling of the moderator. Emergency Operating scram response procedures do not include reset of the feedwater isolation signal for low Tavg coincident with P-4, or restart of the Main Feedwater Pumps. After Emergency Operating procedures are exited, Normal Operating procedures are entered. The Normal Operating procedures provide the Operator options to restart the Steam Driven Main Feedwater Pumps, or the Startup Feedwater pump, or continue to maintain SG water level using the Auxiliary Feedwater Pumps.

Plant start up procedures do not place the Steam Driven Feedwater Pumps in service until after the reactor is restarted and producing power above the point of adding heat. This is due to the high steam demand needed for motive force.

The following information is from the WCGS Technical Specification Bases and describes the functions of the ESFAS interlock -Reactor Trip/P-4 (which include feedwater isolation coincident with P-4):

#### -Engineered Safety Feature Actuation System Interlocks - Reactor Trip, P-4

The P-4 interlock is enabled when a reactor trip breaker (RTB) and its associated bypass breaker is open. Manual reset of SI following a 60 second time delay, in conjunction with P-4, generates an automatic SI block. This Function allows operators to take manual control of SI systems after the initial phase of injection is complete. Once SI is blocked, automatic actuation of SI cannot occur until the RTBs have been manually

## FAQs - By Cornerstone/PI

### Initiating Events

#### IE04 – Unplanned Scrams with Complications

Number	Cornerstone	PIs	Date Entered
--------	-------------	-----	--------------

closed.

The functions of the P-4 interlock are:

- Trips the main turbine;
- *Isolates MFW with coincident low Tave;*[emphasis added]
- Allows manual block of the automatic reactivation of SI after a manual reset of SI; and
- Allows arming of the steam dump valves and transfers the steam dump from the load rejection Tave controller to the plant trip controller; and
- Prevents opening of the MFW isolation valves if they were closed on SI or SG Water Level – High High.

*Each of the above Functions is interlocked with P-4 to avert or reduce the continued cooldown of the RCS following a reactor trip. An excessive cooldown of the RCS following a reactor trip could cause an insertion of positive reactivity with a subsequent increase in core power. To avoid such a situation, the noted Functions have been interlocked with P-4 as part of the design of the unit control and protection system.* [emphasis added]

Based on the emphasized information above, normal main feedwater is not required and unavailability does not impact normal scram recovery actions. A review of the Updated Safety Analysis Report showed that the Main Feedwater Pumps are not credited in the safety analysis for Wolf Creek Generating Station.

Wolf Creek Nuclear Operating Corporation's (WCNOC) position is that current plant design, which includes an Engineered Safety Features Actuation System (ESFAS) interlock (Reactor Trip, P-4) to prevent feeding the SGs with the Main Feedwater System when Tavg is < 564??F (no-load Tavg is 557 ??F) and the reactor tripped, along

## FAQs - By Cornerstone/PI

### Initiating Events

#### IE04 – Unplanned Scrams with Complications

with normal scram response procedures that do not permit reset of this signal, would result in answering “No” to the question “Was Main Feedwater unavailable or not recoverable using approved plant procedures following the scram?” WCNOC’s position is based on the following guidance contained in NEI 99-02:

- NEI 99-02, Page 17, describes the purpose of Unplanned Scrams with Complications Indicator as follows: “This indicator monitors that subset of unplanned automatic and manual scrams that require additional operator actions beyond that of a normal scram. Such events or conditions have the potential to present additional challenges to the plant operations staff and therefore, may be more risk-significant than uncomplicated scrams.” As described above, the condition of the Main Feedwater Pumps (tripped) does not require additional operator actions in response to a scram. The normal scram response procedures do not reset the P-4/Lo TAVG signal, and do not recover the Main Feedwater Pumps.
- NEI 99-02, Page 19, describes criteria for answering the question “Was Main Feedwater unavailable or not recoverable using approved plant procedures following the scram?”. This section states the following: “If design features or procedural prohibitions prevent restarting Main Feedwater this question should be answered as ‘No’.” As described earlier, plant design (P-4 interlock) prevents restarting Feedwater and the scram response procedures to not permit resetting of the Feedwater Isolation signal for Low Tavg coincident with P-4.
- NEI 99-02, page H-4, Section H 1.5, second paragraph, which states: “Some other designs have interlocks in place to prevent feeding the steam generators with main Feedwater unless reactor coolant temperature is greater than the no-load average temperature. These plants should also answer this question as ‘No’ and move on.” As described above, the P-4 interlock coincident with Lo Tavg isolates Main Feedwater and prevents feeding Steam Generators any time the reactor trip breakers are open and Tavg is below 564 °F.

## FAQs - By Cornerstone/PI

### Initiating Events

#### IE04 – Unplanned Scrams with Complications

Number	Cornerstone	PIs	Date Entered	
				<p>If Auxiliary Feedwater cannot maintain adequate decay heat removal for any reason, guidance is provided in emergency response procedure EMG FR H-1, "Response to Loss of Secondary Heat Sink," to restore the Main Feedwater System on a loss-of-all-feedwater flow to the steam generators. It gives directions to defeat isolation signals by installing four to six jumpers per SG behind the main control boards. Utilization of this pathway would result in a scram with Complications because WCNOG would have to answer 'Yes' to the next question, "Was the scram response procedure unable to be completed without entering another EOP?" found on page 20, lines 2 &amp; 3 and Figure 2.</p>
				<p>In summary, this performance indicator was developed to track scrams where operators were required to perform actions outside of those expected for a normal scram. The importance of Main Feedwater as a mitigating system varies by plant design, and in WCNOG's case, Main Feedwater is not required for response to normal uncomplicated scrams. Availability of a component or system <u>when not required</u> should not be considered a factor for this indicator. While WCNOG was not satisfied with the performance of the Main feedwater pumps in this instance, their performance is monitored through Maintenance Rule indicators that are separate from the indicator discussed in this FAQ.</p>
				<p>Although WCNOG reported an earlier SCRAM as complicated with similar circumstances, this should not be set as precedence. This was reported without a detailed review of the NEI 99-02 guidance contained in Attachment H.</p>
				<p><u>NRC Senior Resident Inspector Position:</u></p>
				<p><b>SRI Position Summary</b></p>
				<p>The SRI disagrees with Wolf Creek and feels that the April 28 trip should have been reported as a scram with complications. On April 28, 2009, Wolf Creek did not have the ability to restore and use main feedwater in normal or emergency operating procedures because all three main feedwater pumps required maintenance, and not because of isolation signals. Any of the three main feedwater pumps can be</p>

## FAQs - By Cornerstone/PI

### Initiating Events

#### IE04 – Unplanned Scrams with Complications

Number	Cornerstone	PIs	Date Entered
--------	-------------	-----	--------------

procedurally started in Mode 3. The FWIS, including P4+Tavg <564F and lo lo S/G level, can be cleared with the pushbuttons or jumper wires per normal or emergency operating procedures. Page H-4, lines 27 to 29 state that the PI measures the **ability** [emphasis added] to implement emergency procedures on loss of auxiliary feedwater. Actual implementation of other emergency procedure is monitored elsewhere. This approach is also consistent with page H-5, lines 20-23, which provide for clearing of isolation signals in order to use main feedwater.

#### **SRI Basis**

The SRI believes that although there is a Feedwater Isolation Signal (FWIS, P4 interlock), the April 28, 2009 scram should still count towards the Scrams with Complications PI. Wolf Creek procedure GEN 00-005, "Minimum Load to Hot Standby," revision 62 directs reactor operators to depress the FWIS reset pushbuttons and check that the P4 FWIS annunciator is clear. Main feedwater valves can then be opened even if reactor trip breakers are open, coincident with reactor coolant system temperature below 564F. The control room pushbutton circuitry has a retentive memory device and the valves will remain open until the reactor trip breakers are cycled or the RCS goes above and below 564F. If this happens a second time, the reset button can be depressed again and main feedwater can be re-established. This interlock does not prevent feeding the steam generators with main feedwater because of normal (GEN 5) and off-normal (EMG FR-H1) plant procedures and the reset pushbutton. The SRI felt page H-5, lines 20 to 23 state that a FWIS does not constitute a loss of main feedwater as long as it can be cleared and feedwater restarted. Procedure EMG FR-H1 also provides instructions for reactor operators to clear the P4+564F and lo lo steam generator level signals with jumper wires. The FWIS handswitch could also be used for P4. The flow path was viable.

The SRI agrees with Wolf Creek's position that actual use of EMG FR-H1 would count towards the PI because of entry into another EMG per NEI 99-02 section H 1.6. The plant trip on April 28, 2009, did not require entry into procedure EMG FR H1.

Procedure EMG FR-H1 allows and provides steps to use any of the three main feed

## FAQs - By Cornerstone/PI

### Initiating Events

#### IE04 – Unplanned Scrams with Complications

Number	Cornerstone	PIs	Date Entered	
				<p>pumps. However, if procedure EMG FR H1 was used on April 28, 2009, the main feedwater portion of the procedure would not have been successful because all three main feedwater pumps required maintenance (speed switch, servo valve, and a circuit breaker). Consistent with page 19 of NEI 99-02, Revision 6 and page H-4, lines 24 to 29, the PI monitors the ability of main feedwater to be used to feed the steam generators if necessary in emergency operating procedures. On April 28, 2009, Wolf Creek did not have the ability to restore and use main feedwater in normal or emergency operating procedures because all three main feedwater pumps needed maintenance, and not because of isolation signals.</p> <p>Wolf Creek does not appear to be a design that applies to page H-4, lines 36 to 38. The P4 FWIS occurs with Tave at 564F which is above no load Tave of 557F cited on page H-4. A Tave of 564F corresponds to a reactor power of approximately 11%. The Wolf Creek total plant setpoint document defines low Tave as 553F (P-12) and lo lo Tave as 550F (Turbine loading stop). If auxiliary feedwater actually failed, and EMG FR-H1 was used, then the RCS is likely to be at 557F or above. RCS temperature is likely not to be a concern prohibiting initial use of main feedwater until the plant is cooled below 564F and the signal would have to be reset again.</p> <p>Wolf Creek did count the March 2008 scram as complicated. There is no discussion of the main feedwater in Wolf Creek's NRC PI procedure.</p> <p>Expected reactor trip parameters should not be used as a reason to exclude main feedwater availability from this performance indicator. But, if the NEI/NRC ROP Working Group determines that Wolf Creek is correct, then the Appendix H should be rewritten to explicitly exclude Westinghouse units from the main feedwater availability portion of this performance indicator.</p> <p><u>Potentially Relevant Existing FAQ Numbers:</u> None</p> <p><b><u>Response</u></b> <u>Proposed Resolution of FAQ:</u></p>

FAQs - By Cornerstone/PI

Initiating Events

IE04 – Unplanned Scrams with Complications

Number	Cornerstone	PIs	Date Entered
--------	-------------	-----	--------------

This event should not count against the Unplanned Scrams w/Complications PI.

NRC Response to the FAQ:

The April 28, 2009 reactor trip at WCGS will be counted as an Unplanned Scram with Complications.

After an extensive review of the guidance in NEI 99-02 and detailed discussions at three ROP Working Group public monthly meetings, the key factor in determining MFW unavailability is the material health of the system (i.e., the system must be free from damage and shall not require repair or maintenance to restore availability). Any active design features (e.g., interlocks or signals that isolate MFW after a reactor trip) used as the basis in answering “No” to the question “Is MFW Unavailable?” is applicable only if the MFW system is free from damage and does not need repair or maintenance (i.e., the MFW system is capable of performing its intended function if called upon).



FAQs - By Cornerstone/PI

Initiating Events

IE04 – Unplanned Scrams with Complications

Number	Cornerstone	PIs	Date Entered	
--------	-------------	-----	--------------	--

467

IE

IE04

10/15/2009

**Question**

NEI 99-02 Guidance needing interpretation:

Page 21-22, "Was Main Feedwater not available or not recoverable using approved plant procedures?"

If operating prior to the scram, did Main Feedwater cease to operate and was it unable to be restarted during the reactor scram response?<sup>1</sup> The consideration for this question is whether Main Feedwater could be used to feed the reactor vessel if necessary.<sup>2</sup> The qualifier of "not recoverable using approved plant procedures" will allow a licensee to answer "No" to this question if there is no physical equipment restraint to prevent the Operations staff from starting the necessary equipment, aligning the required systems, or satisfying required logic circuitry using plant procedures approved for use that were in place prior to the scram occurring.

The Operations staff must be able to start and operate the required equipment using normal alignments and approved normal and off-normal operating procedures. Manual operation of controllers/equipment, even if normally automatic, is allowed if addressed by procedure. Situations that require maintenance activities or non-proceduralized operating alignments will not satisfy this question. Additionally, the restoration of Main Feedwater must be capable of being restored to provide feedwater to the reactor vessel in a reasonable period of time. Operations should be able to start a Main Feedwater pump and start feeding the reactor vessel with the Main Feedwater system within 30 minutes.<sup>3</sup> During startup conditions where Main Feedwater was not placed in service prior to the scram, the question would not be considered, and should be skipped.

Event or circumstances requiring guidance interpretation:

On 11/26/2008, at 1200 hours (EST), Unit 1 scrambled when a Group 1 primary containment isolation occurred, resulting in an automatic actuation of the Reactor Protection system. Investigation determined that a pressure-load gate amplifier circuit

## FAQs - By Cornerstone/PI

### Initiating Events

#### IE04 – Unplanned Scrams with Complications

Number	Cornerstone	PIs	Date Entered
--------	-------------	-----	--------------

board in the Electro-Hydraulic Control (EHC) system operated erroneously. The Main Steam (MS) isolation valves (MSIVs) closed on the Group 1 isolation. As designed and described in Brunswick operating procedures, following a Group 1 isolation with the MSIVs closed, Reactor Core Isolation Cooling (RCIC) was used to effectively maintain reactor water level. At approximately 1241 hours, IAW 1OP-25 (MS System Operating Procedure), low condenser vacuum switches are placed in bypass to support resetting the Group 1 isolation. A few steps later, the Main Steam supply valve 1-MS-V28 is closed by the Operator in preparation for re-opening the MSIVs (this valve provides main steam to the Reactor Feed Pumps). Note that during the approximately 40 minutes of the initial scram response the 1 MS-V28 valve remained open and available. At 1511, Operations reopened the MSIVs, per 1OP-25. A few steps later, an attempt was made to open the Main Steam supply valve 1 MS V28 from the Control Room, but the valve did not open. An attempt was made to manually open the valve, however, the valve was thermally bound and would not open. Main Feedwater was not needed for reactor water level control, as RCIC was being effectively utilized for level control. Engineering was contacted to provide torque values to be used to open the valve. After shift turnover, and early in the next shift (after 1800 hours), the Operators attempted to manually open the 1 MS-V28 valve with the use of the provided torque values, however they found the valve was no longer thermally bound closed and opened it by hand.

#### Questions requiring interpretation:

1 - The first line of the guidance states "did Main Feedwater cease to operate and was it unable to be restarted during the reactor scram response?"

Main Feedwater (FW) ceased to operate upon the Group 1 isolation (MS lines, MS drain lines, Recirc sample valves). Immediately following the scram, an expected reactor vessel coolant level shrink occurred. As a result of the low water level, primary containment Group 2 (DW equipment and floor drains, TIPs, RHR discharge to RW, and RHR process sample valves) and Group 6 (CAC/CAD, CAM, and Post-Accident Sampling system) isolation signals were received. All required isolations occurred properly as a

## FAQs - By Cornerstone/PI

### Initiating Events

#### IE04 – Unplanned Scrams with Complications

Number	Cornerstone	PIs	Date Entered
			<p>result of the reactor low water level isolation signals. All control rods fully inserted on the scram and all safety-related systems responded as designed. No Safety Relief Valves (SRVs) lifted during the scram. Per established procedures, the RCIC system was manually started to restore reactor water level to the normal band (note that RCIC is used for both level and pressure control).</p> <p>Normal operating procedure following a Group 1 isolation (with MSIVs closed) is to use RCIC for feeding the reactor vessel. It wasn't until approximately three hours and fifteen minutes after the scram occurred that Operations began the system alignment to get MS, and thus FW, back. At that point, the reactor scram response was essentially complete and recovery actions were in progress. The failure of the 1 MS V28 valve to initially open at a later time and allow the restart of FW did not impact Operator response during the initial transient. No additional procedures were entered beyond the normal scram response procedure.</p> <p>2 - From the second sentence in the guidance, "The consideration for this question is whether Main Feedwater could be used to feed the reactor vessel if necessary."</p> <p>Per design, Main Feedwater ceased to operate once the Group 1 isolation occurred, and per procedure, RCIC was successfully used to maintain reactor water level. Main Feedwater was not required as part of the normal scram response procedure. This scram presented no significant challenges to the Operations personnel during the reactor scram response, and normal operating procedures were used.</p> <p>3 - Guidance states that "Main Feedwater must be capable of being restored to provide feedwater to the reactor vessel in a reasonable period of time. Operations should be able to start a Main Feedwater pump and start feeding the reactor vessel with the Main Feedwater system within 30 minutes."</p> <p>During the first 41 minutes (approximate) of the initial reactor scram response, valve 1-MS-V28 remained open, and thus not subject to the thermal binding conditions</p>

## FAQs - By Cornerstone/PI

### Initiating Events

#### IE04 – Unplanned Scrams with Complications

Number	Cornerstone	PIs	Date Entered
--------	-------------	-----	--------------

encountered approximately three hours later. As noted above, it wasn't until approximately three hours and fifteen minutes after the scram occurred that Operations began the system alignment to get MS, and thus FW, back. There was no attempt to use Main Feedwater "during the reactor scram response," as RCIC was providing adequate feed to the reactor vessel. As previously described, this is the preferred method of reactor water inventory control following a Group 1 isolation.

In summary, Main Feedwater was capable of being restored to feed the reactor vessel in a reasonable amount of time. It is believed that within the first 30 minutes following the scram, with valve 1-MS-V28 still open, Main Feedwater was available as a source to provide reactor vessel level if needed. However, the timeline of events discussed above does not allow Brunswick to quantify that timeframe as prescribed in NEI 99-02. Thus, the NEI 99-02 guidance requires clarification as to what constitutes the "reactor scram response," and at what point are the entry conditions for the indicator exited.

#### NRC Senior Resident Inspector position:

"For this event specifically, I think the question boils down to – could main feed have been restored had RCIC and HPCI not functioned correctly? For the first 40 minutes after the scram when the steam isolation valve to main feed was open, would the same sequence of events occurred if operators tried to restore main feed , i.e. would the valve have been shut during restoration and subjected to the same conditions that caused the thermal binding? If not, then you probably have a good argument for no complications. If the valve would have been subjected to the same conditions that caused the thermal binding, then I think it should be classified as a scram with complications."

The NRC Senior Resident Inspector also does not agree with the proposed rewording of the guidance. For the proposed change to Page 21 (see the Response on the following page), "it would not capture those events that are of higher safety significance because

## FAQs - By Cornerstone/PI

### Initiating Events

#### IE04 – Unplanned Scrams with Complications

Number	Cornerstone	PIs	Date Entered
--------	-------------	-----	--------------

main feed is not available, even if it was not required to be used," and "30 minutes is a completely arbitrary number." Similarly for the proposed change to page 22, even if the main feed steam supply is temporarily isolated, the PI should capture those events where main feed couldn't be restored in a relatively short time. "It might be different if the equipment was designed such that restoration was not possible, but in this case main feed should have been available and it was not." For our situation, he asked what would've happened if RCIC quit operating after an hour or hour and a half, i.e., at some time following 1241 when 1-MS-V28 was closed. The activity to restart Feedwater at that point should still be considered part of the scram response.

Potentially relevant existing FAQ numbers: None.

#### **Response**

Proposed Resolution of FAQ:

This event should not count against the Unplanned Scrams w/Complications PI.

This event did not lend itself well to determining if a Scram with Complications occurred based on the specific narrow focus of the questions in the flowchart on page 19 of NEI 99-02, Revision 5. This guidance focuses on whether feedwater was available for the first 30 minutes into the event, or approximately what could be considered the "scram response phase" of the transient. In this situation for the event in question, it is likely that feedwater was available for the first 30 minutes, so this event should not count against the indicator based on the current wording of the guidance. However, the guidance in NEI 99-02, Revision 5 should be reviewed to see if it needs to be revised based on circumstances that might require the availability of feedwater beyond 30 minutes and whether consideration of the scram response time window remains an appropriate marker for judging a complication to recovery from an unplanned scram. These questions will be addressed in a subsequent generic FAQ.

FAQs - By Cornerstone/PI

Mitigating Systems

MS05 MS06 MS07 MS08 MS09 MS10

Number	Cornerstone	PIs	Date Entered	
484	MS	MS05 MS06 MS07 MS08 MS09 MS10	9/21/2011	<p><b><u>Question</u></b></p> <p>NEI 99-02 section F.5 page F-45 provides inconsistent treatment of EDG Fuel Oil Transfer pumps (FOTPs). The FOTPs are identified as being within the system boundary but are not monitored components nor do they contribute to the unavailability unless there is only one pump per EDG. As noted in the guidance, the reason for this treatment is that the FOTP contribution to MSPI was expected to be small. Additional investigation has shown that for some plant configurations, the contribution from the FOTPs could be significant, based on plant design details such as number of pumps, number of EDGs, Day Tank Capacity, cross connect capability, etc. Therefore, appropriate consideration of the FOTPs in MSPI is needed.</p> <p>Several options for adding the FOTPs to MSPI were investigated, including added the pumps as separate monitored components or considering them within the boundary of the EDG super-component. Based on limitations of the current Consolidated Data Entry software design, it was determined that inclusion of the FOTPs as being with the EDG super-component boundary is the most cost effective option available.</p> <p><b>Guidance needing clarification/interpretation:</b></p> <p>Revise NEI 99-02 section F.5 and Figure F-1 to include the Fuel Oil Transfer Pumps within the EDG super-component boundary.</p> <p><b>Event requiring guidance interpretation:</b></p> <p>N/A. This FAQ is for general guidance improvement and does not address a specific event.</p> <p><b>NRC Resident Inspector Position:</b></p> <p>The NRC is in agreement with the need to revise guidance on the treatment of Fuel Oil Transfer Pumps.</p>

**If licensee and NRC resident/region do not agree on the facts and circumstances**

FAQs - By Cornerstone/PI

Mitigating Systems

MS05 MS06 MS07 MS08 MS09 MS10

Number	Cornerstone	PIs	Date Entered
--------	-------------	-----	--------------

explain:

NA.

**Potentially relevant existing FAQ numbers:** NA. [During ROPTF review, this FAQ was identified as #11-07.]

**Response**

**Proposed Resolution of FAQ:**

It is recommended that the following proposed wording changes be incorporated into NEI 99-02.

**Licensee proposed wording changes:**

**Bolded, italicized, and underlined phrases indicate proposed changes**, and strike-throughs indicate deletions.

Page F-17: Line 37

1) INCLUDE all pumps (except EDG fuel oil transfer pumps **which are part of the EDG super component**) and diesels

Page F-19, Table 2

The diesel generator boundary includes the generator body, generator actuator, lubrication system (local), fuel system (local), **fuel oil transfer pumps/valves**, cooling components (local), startup air system receiver, exhaust and combustion air system, dedicated diesel battery (which is not part of the normal DC distribution system), individual diesel generator control system, cooling water isolation valves, circuit breaker

## FAQs - By Cornerstone/PI

### Mitigating Systems

MS05 MS06 MS07 MS08 MS09 MS10

Number	Cornerstone	PIs	Date Entered
--------	-------------	-----	--------------

for supply to safeguard buses and their associated control circuit (relay contacts for normally auto actuated components, control board switches for normally operator actuated components<sup>1</sup>).

Page F-45: Line 33 – Page F-46 Line 2

The EDG component boundary includes the generator body, generator actuator, lubrication system (local), fuel system (local or day tank **and fuel oil transfer pumps/valves**), cooling components (local), startup air system receiver, exhaust and combustion air system, dedicated diesel battery (which is not part of the normal DC distribution system), individual diesel generator control system, cooling water isolation valves, circuit breaker for supply to safeguard buses and their associated control circuit. Air compressors are not part of the EDG component boundary.

The fuel transfer pumps required to meet the PRA mission time are within the **EDG component** system boundary but are not considered to be a **separate** monitored component for reliability monitoring in the EDG system. Additionally they are monitored for contribution to train unavailability only if **the fuel oil transfer pump(s) is (are) required to meet the EDG mission time (as specified in Section F.2.2.2 and as defined in the MSPI Definition of Terms section)**. ~~an EDG train can only be supplied from a single transfer pump. Where the capability exists to supply an EDG from redundant transfer pumps, the contribution to the EDG MSPI from these components is expected to be small compared to the contribution from the EDG itself. Monitoring the transfer pumps for reliability is not practical because accurate estimations of demands and run hours are not feasible (due to the auto start and stop feature of the pump) considering the expected small contribution to the index.~~

(See also EDG failure to run definition in Section F.2.2.2. (FAQ 11-08))

Page F-55, Figure F-1



FAQs - By Cornerstone/PI  
 Mitigating Systems  
 MS05 MS06 MS07 MS08 MS09 MS10

Number	Cornerstone	PIs	Date Entered
--------	-------------	-----	--------------

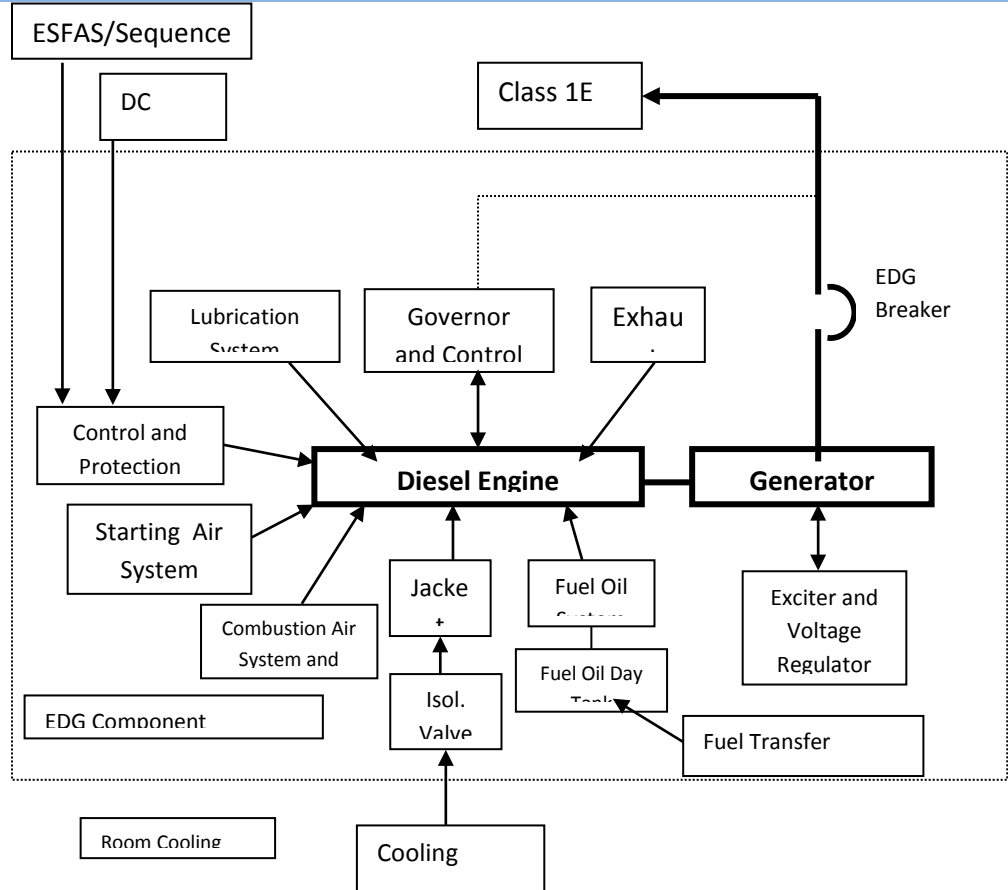

- The Fuel Transfer Pump(s)/Valve(s) are included in the EDG Component System Boundary. See Section 5 for monitoring requirements.

*NRC Response to FAQ:*

FAQs - By Cornerstone/PI

Mitigating Systems  
MS05 MS06 MS07 MS08 MS09 MS10

Number	Cornerstone	PIs	Date Entered	
				<p>NRC staff agrees with the proposed changes with an effective date of January 1, 2012, meaning that licensees will begin applying this FAQ resolution to 1Q2012 data reported to NRC in April 2012.</p>
477	MS	MS05 MS06 MS07 MS08 MS09 MS10	2/16/2011	<p><b><u>Question</u></b> NEI 99-02 section 2.2, Mitigating System Performance Index, pages 33-34, provide the guidance on when an MSPI Basis Document Revision is required and also provides guidance on reporting changes to the MSPI Basis Document and CDE as part of the quarterly data submittals. The current requirements have led to multiple interpretations of when to make these changes and do not discuss the level of detail required in reporting changes to either the basis document or MSPI coefficients.</p> <p><b>Guidance needing clarification/interpretation:</b></p> <p>Add clarification to NEI 99-02 section 2.2 to provide details on when an MSPI basis document change is required and the level of detailed required to be supplied via comments in CDE when changes to either the basis document or CDE are made.</p> <p><b>Event requiring guidance interpretation:</b></p> <p>N/A. This FAQ is for general guidance improvement and does not address a specific event.</p> <p><b>NRC Resident Inspector Position:</b></p> <p>The NRC is in agreement with the need to provide additional guidance on MSPI Basis Document Changes</p> <p><b>If licensee and NRC resident/region do not agree on the facts and circumstances explain:</b></p>

FAQs - By Cornerstone/PI

Mitigating Systems

MS05 MS06 MS07 MS08 MS09 MS10

Number	Cornerstone	PIs	Date Entered
--------	-------------	-----	--------------

NA.

Potentially relevant existing FAQ numbers: N/A

**Response**

Effective 10/1/2011

**Proposed Resolution of FAQ:**

It is recommended that the following proposed wording changes or changes with equivalent meaning be incorporated into NEI 99-02.

**Licensee proposed wording changes:**

**Bolded and underlined phrases indicate proposed changes**, strike-throughs indicate deletions.

Page F-33 & 34

**Clarifying Notes**

**Documentation and Changes**

Each licensee will have the system boundaries, monitored components, and monitored functions and success criteria which differ from design basis readily available for NRC inspection on site. Design basis criteria do not need to be separately documented. Additionally, plant-specific information used in Appendix F should also be readily available for inspection. An acceptable format, listing the minimum required information, is provided in Appendix G. **As stated in the Introduction section of NEI 99-02, plant-specific comments should be provided in the data submittal when either the MSPI basis document or an MSPI coefficient is changed. Changes to the site PRA of record, the site basis document, and the CDE database should be made in accordance**

## FAQs - By Cornerstone/PI

### Mitigating Systems

MS05 MS06 MS07 MS08 MS09 MS10

Number	Cornerstone	PIs	Date Entered
--------	-------------	-----	--------------

**with the following:**

~~**Changes to PRA coefficient**~~ **PRA Model Revisions:** Updates to the MSPI coefficients developed from the plant specific PRA will be made as soon as practical following an update to the plant specific PRA **(which are directly obtained from the plant specific PRA) will be made in the quarter following approval of an update to the plant specific PRA of record.** The revised coefficients will be used in the MSPI calculation the quarter following the update. Thus, the PRA **MSPI** coefficients in use at the beginning of a quarter will remain in effect for the remainder of that quarter. **In addition,** Changes to the CDE database and MSPI basis document that are necessary to reflect changes to the plant specific PRA of record should be incorporated **prior to the next quarter's data submittal** as soon as practical but need not be completed prior to the start of the reporting quarter in which they become effective. The quarterly data submittal should include a comment that provides a summary of any changes to the MSPI coefficients. The comments automatically generated by CDE when PRA coefficients are changed do not fulfill this requirement. The plant must generate a plant-specific comment that describes what was changed. Any PRA model changes will take effect the following quarter (model changes include error, corrections, updates, etc.). For example, if a plant's PRA model of record is approved on September 29 (3rd quarter), MSPI coefficients based on that model of record should be used for the 4th quarter. **Updates to the MSPI basis document and the** The calculation of the new coefficients should be completed (including a revision of the MSPI basis document if required by the plant specific processes) and input to CDE **database should be made** prior to reporting the 4th quarter's data (i.e., completed by January 21).

***Changes to non-PRA information:*** Updates to information that is not directly obtained from the PRA (e.g., unavailability baseline data, estimated demands/run hours) **can affect both the MSPI basis document and the MSPI inputs into the CDE database. Changes to the MSPI basis document and MSPI inputs into the CDE database that are needed to reflect changes to non-PRA information will be made prior to the next quarterly data submittal. This does not imply that any change to estimated demands/run hours is**

FAQs - By Cornerstone/PI

Mitigating Systems

MS05 MS06 MS07 MS08 MS09 MS10

Number	Cornerstone	PIs	Date Entered
--------	-------------	-----	--------------

required to be reflected in the MSPI Basis Document or CDE (Appendix F Section F.2.2.1 for requirements on when MSPI Basis Document and CDE changes are required for estimated demands/run hours). will become effective in the quarter following an approved revision to the site MSPI basis document. Changes to the CDE database that are necessary to reflect changes to the site basis document should be incorporated as soon as practical but need not be completed prior to the start of the reporting quarter in which they become effective. The quarterly data submittal should include a comment that provides a summary of any changes to the **MSPI** basis document **and inputs to the CDE database**. The comments automatically generated by CDE when PRA coefficients are changed do not fulfill this requirement. The plant must generate a plant-specific comment that describes what was changed **For example, changes to planned unavailability baseline that do not require a change to the PRA model must be documented in an MSPI basis document revision in the quarter prior to the revised values being used as inputs into the CDE database.**

**Plant Modifications: Any changes to the plant should be evaluated for their impact on the MSPI basis document, MSPI inputs into the CDE database, and the PRA of record. Plant modifications have the potential to involve both changes to the PRA model and non-PRA information, while some modifications may be limited to either the PRA model or non-PRA information. Modifications to the plant design that result in a change to segment or train boundaries, monitored components, or affect monitored functions or success criteria, shall be reflected in the MSPI basis document the quarter following the completed implementation. Additionally, if modifications are made to sub-components within the boundary of a monitored component (such as the replacement of an emergency AC voltage regulator with a different type) and that sub-component is described in the basis document, the basis document should be updated to reflect the sub-component modification the quarter following the completed implementation.**

**If the plant modification has the potential to impact the PRA model in a manner that**

FAQs - By Cornerstone/PI

Mitigating Systems

MS05 MS06 MS07 MS08 MS09 MS10

Number	Cornerstone	PIs	Date Entered
--------	-------------	-----	--------------

affects MSPI results, the modification shall be evaluated to determine if it results in a factor of three change in the corrected Birnbaum value of an MSPI monitored train or component. If the new Birnbaum value is greater than 1E-6, the MSPI basis document shall be updated to reflect the new Birnbaum values the quarter following the completed implementation. Note that the use of supplemental evaluations to estimate the revised MSPI inputs for pending PRA model changes is allowed as an interim alternative until the PRA model of record is updated.

Example CDE Comments:

Following a periodic update to a PRA model, the following CDE comment would be appropriate:

The XYZ PRA Model Revision 6 was approved on 7/6/10 with a corresponding MSPI Basis Document Revision 3 approved on 12/21/10. The PRA model revision was a periodic update to the model which included a data update, incorporation of an Auxiliary Feedwater Crosstie between Units and a change in Human Error Probabilities using the EPRI HRA calculator. As a result of the PRA model change, the CDF, Fussel-Vesely and Basic Event Probabilities for all monitored trains and components were revised.

Following a change to baseline unavailability, the following CDE comments would be appropriate:

Scenario 1: Change Results in Negligible ( $\leq 1E-8$ ) Increase in Train Birnbaum

The planned unavailability baseline for the Residual Heat Removal was system was increased by 30 hours per 3 years as a result of a new preventive maintenance task. The increase in planned unavailability baseline was evaluated in the MSPI basis document Revision 3, dated 3/23/11 and concluded that it resulted in a negligible increase in Train

Number	Cornerstone	PIs	Date Entered
--------	-------------	-----	--------------

**Birnbaum values. Therefore, the revised values were incorporated into CDE effective the 2<sup>nd</sup> quarter 2011.**

**Scenario 2: Change Results in Significant (>1E-8) Increase in Train Birnbaum Values**

**The planned unavailability baseline for the Residual Heat Removal system was increased by 30 hours per 3 years as a result of a new preventive maintenance task. The increase in planned unavailability baseline was evaluated in the MSPI basis document Revision 3, dated 3/23/11 and concluded that a revision to the PRA model was required prior to implementing the change. The approved PRA model Revision 4 to reflect this change in planned unavailability was approved on 2/15/11. The revised values were incorporated into CDE effective the 2<sup>nd</sup> quarter 2011.**

**Following a design change that has a significant impact (≥ factor of three increase) on Birnbaum values:**

**A modification was completed on 1/15/11 that removed a monitored MOV in the Residual Heat Removal system. The MSPI basis document Revision 2 was approved on 3/12/11 to account for this impact. As removal of the MOV had a negligible impact on the overall CDF, the PRA model was not updated to reflect this change. The MSPI Basis Document Revision includes an evaluation of the impact on MSPI inputs which will be used until the next revision of the PRA model is completed.**

NRC Response to FAQ:

The staff agrees with the proposed wording changes.

## FAQs - By Cornerstone/PI

### Mitigating Systems

#### MS06

Number	Cornerstone	PIs	Date Entered	
--------	-------------	-----	--------------	--

480

MS

MS06

5/4/2011

#### Question

NEI 99-02 section F.2.2.1, Mitigating System Performance Index, page F-20, provides the guidance for counting EDG run hours. During initiate implementation of MSPI, it was decided to include the 1st hour of run time for the EDGs in the run hours calculations, even though failures within the 1st hour or operation are either EDG demand or Load/Run failures, as it was expected to result in a small impact to the calculated. A recent investigation (ML 101580244) concluded that in order to maintain the industry generic failure rates used as a comparison for MSPI, the 1st hour of operation for the EDGs must be **excluded** from the run hours calculations. Inclusion of the 1st hour or operation results in almost a factor of 1.5 reduction in the industry prior failure rate used for MSPI.

The impact of not counting the 1st hour of operation on historical MSPI reporting identified that excluding the 1st hour of operation from the EDG run hours would not have resulted in any change in indicator color. Therefore, this change will be made for future reporting only.

#### **Guidance needing clarification/interpretation:**

Revise NEI 99-02 section F.2.2.1 and F.2.2.2 eliminate the addition of the 1st hour of EDG operation from the run hour data that is input into the CDE database.

#### **Event requiring guidance interpretation:**

N/A. This FAQ is for general guidance improvement and does not address a specific event.

#### **NRC Resident Inspector Position:**

The NRC is in agreement with the need to revise guidance on MSPI EDG run hour reporting.



FAQs - By Cornerstone/PI

Mitigating Systems

MS06

Number	Cornerstone	PIs	Date Entered
--------	-------------	-----	--------------

If licensee and NRC resident/region do not agree on the facts and circumstances explain:

Potentially relevant existing FAQ numbers: NA

**Response**

**Proposed Resolution of FAQ:**

It is recommended that the following proposed wording changes or changes with equivalent meaning be incorporated into NEI 99-02.

**Licensee proposed wording changes:**

**Bolded and underlined phrases indicate proposed changes**, strike-throughs indicate deletions.

Page F-21: Lines 27 – 32

Run hours (pumps and emergency power generators only) are defined as the time the component is operating. **For pumps**, run hours include the first hour of operation of the component. **For EDGs, exclude all hours before the output breaker is closed (or EDG hours when the EDG is run unloaded) and the first hour after the breaker is closed (the first hour of operation after the breaker is closed is considered part of the load/run demand)**. Exclude post maintenance test run hours, unless in case of a failure, the cause of the failure was independent of the maintenance performed. In this case, the run hours may be counted as well as the failure. Pumps that remain running for operational reasons following the completion of post maintenance testing, accrue run hours from the time the pump was declared operable.

**NRC Response to FAQ:**

NRC staff agrees with the proposed changes. The FAQ resolution will begin to be applied

FAQs - By Cornerstone/PI

Mitigating Systems  
MS06

Number	Cornerstone	PIs	Date Entered
--------	-------------	-----	--------------

[to 1Q2012 data that are reported to the NRC in April 2012.](#)

FAQs - By Cornerstone/PI

Mitigating Systems  
MS06 MS07 MS08 MS09 MS10

Number	Cornerstone	PIs	Date Entered	
473	MS	MS06 MS07 MS08 MS09 MS10	5/26/2010	<p><b><u>Question</u></b>  <b>NEI 99-02 Guidance needing interpretation (include page and line citation):</b></p> <p>Add BFN 1 to Table 7 of Appendix F, Generic CCF Adjustment Values. The values for BFN 1 are the same as those presented for BFN 2 and BFN 3 since all BFN plants are of the same design.</p> <p><b>Event or circumstances requiring guidance interpretation:</b></p> <p>Return of BFN 1 to operating status during summer of 2007</p> <p><b>If licensee and NRC resident/region do not agree on the facts and circumstances explain</b></p> <p>NA</p> <p><b>Potentially relevant existing FAQ numbers</b></p> <p>NA</p> <p><b><u>Response</u></b>  <b>Proposed Resolution of FAQ</b></p> <p>Add BFN 1 to Table 7 of Appendix F with plant-specific Generic CCF Adjustment Values.</p> <p>If appropriate, provide proposed rewording of guidance for inclusion in next revision.</p>

FAQs - By Cornerstone/PI

Mitigating Systems  
MS06 MS07 MS08 MS09 MS10

Number	Cornerstone	PIs	Date Entered
--------	-------------	-----	--------------

The following is proposed to be added to Appendix F, Table 7:

	EDG	MDP Running or Alternating+	MDP Standby	TDP **	MDP Standby
Browns Ferry 1	1.25	1	1	1	3

Figure E-1

FAQs - By Cornerstone/PI

Mitigating Systems

MS06 MS07 MS08 MS09 MS10

Number	Cornerstone	PIs	Date Entered	
472	MS	MS06 MS07 MS08 MS09 MS10	12/12/2009	<b>Question</b>

An industry practice (used by some licensees for some equipment) is to consider equipment potentially “available,” upon completion of maintenance but prior to the performance of the post maintenance test (PMT). This determination of availability is typically performed independent of operations personnel, and is made after the completion of the PMT. If the equipment passes its PMT, the status of the equipment between the completion of maintenance and the PMT is scored for MSPI purposes as “available.” This approach creates the potential for inconsistency with the treatment of recovery actions to restore the monitored functions where explicit guidance is provided for recovery from testing and operational alignments but not from maintenance. The current guidance associated with the transition between unavailability to availability results in the potential for limited operator awareness, the potential for non-conservative treatment of equipment reliability and the potential for regulatory inconsistency.

**NEI 99-02 Guidance needing interpretation/revision:**

There is no explicit guidance in NEI 99-02 or NUMARC 93-01 (“Industry Guideline for Monitoring the Effectiveness of Maintenance at Nuclear Power Plants”, Rev. 3, published by NEI, July 2000) on requirements for scoring the transition from an unavailable state to an available state. Although industry guidance for the recovery of testing or operational alignment could be considered a minimum set of requirements, as these requirements are related to the determination of equipment availability, it appears that application of this guidance to post-maintenance return to service is not a typical practice.

Basis for Revising NEI 99-02, Appendix F, Section F1.2.1

1. **Lack of Clear Guidance**

Unlike operability, recovery of testing or operational alignment (NEI 99-02, Revision 6, Appendix F, Section 1.2.1), and treatment of test-related human

FAQs - By Cornerstone/PI

Mitigating Systems

MS06 MS07 MS08 MS09 MS10

Number	Cornerstone	PIs	Date Entered
--------	-------------	-----	--------------

errors (Industry White Paper), there is no explicit guidance in NEI 99-02 or NUMARC 93-01 on requirements for scoring the transition from an unavailable state to an available state. One significant difference between the test/operational alignment recovery, and post-maintenance return to service, is the extra failure potential that exists in the latter case, owing to the maintenance action's possible inefficacy. As a result, more requirements, not fewer, would need to be met in order to justify a conclusion of "availability." The present lack of clear guidance results in the potential for scoring the transition from an unavailable state to an available state based on the use of a post-maintenance decision process in which availability is considered to commence on removal of clearance tags, independent of operations. Such a practice does not meet the staff's expectations.

2. **Potential for Limited Operator Awareness**

The industry's white paper on this subject dated December 10, 2008 states that most of the licensees contacted use a process in which operators determine "operability" while other personnel (usually system engineers) determine "availability." The paper further states that this determination is made several days or weeks after the SSC was declared operable. The paper also states that most (but not all) licensees do not credit the availability of a SSC, in this available/not operable state, in their online risk assessment.

A logical conclusion is that plant operations is largely decoupled from the process of determining the degree of credit that is taken for the mitigation capability of these monitored components. This decoupling increases the staff concern regarding the industry presumption that recovery of the equipment (if not readied for operation or aligned for auto-start) at the time it is considered transferred for the unavailable to available state is so likely that additional unavailability time does not need to be counted.

Number	Cornerstone	PIs	Date Entered
--------	-------------	-----	--------------

3. ***Potential for Degraded Equipment Reliability***

There are two key considerations associated with equipment reliability during the “available” / not operable state: (1) transition point from unavailable to available, and (2) role of the post-maintenance test.

Transition Point from Unavailable to Available

Although this is not stated explicitly by industry, the staff believes that the transition point used by industry is the time at which the clearance tags are logged as being removed. However, as noted above, it is the staff’s understanding that the removal of these tags does not necessarily mean that the equipment is aligned and fully functional. The equipment may require additional alignments in accordance with the appropriate operating instructions (e.g., system refilling and venting may be required) prior to being returned to service. In addition, the equipment controls may remain in pull-to-lock pending completion of equipment line-ups and the post-maintenance tests. If operators are aware that the equipment has not been tested, they are less likely to initiate manual recovery actions. The criterion for determining “availability” should be that restoration actions are virtually certain to succeed. This criterion corresponds to the criterion used for restoration following testing.

Post Maintenance Testing

Equipment adjustments or tuning may occur during the PMT. Such adjustments are unlikely to be reported as a PMT failure, but may improve the reliability of the equipment.

Calculated Unavailability

FAQs - By Cornerstone/PI

Mitigating Systems

MS06 MS07 MS08 MS09 MS10

Number	Cornerstone	PIs	Date Entered
--------	-------------	-----	--------------

Industry has provided a white paper that demonstrates that the current industry approach is correct *given certain assumptions*. These assumptions are: (1) The transition point from an unavailable state to an available state represents a transition to a return to service condition where the system is aligned for operations, and operations is aware that it is aligned and that it will automatically start on a valid starting signal or can be promptly restored; (2) No equipment adjustments or tuning occur during the PMT. Under these conditions, the calculations presented by industry appear correct.

**Potential for Inconsistency in the ROP**

The lack of guidance on determining the “available”/not operable state and the noted variability in this determination lead to inconsistency in the MSPI indicators, which can result in a reduction of public confidence.

**Event or circumstances requiring guidance interpretation:**

In Section F.1.2.1, “Actual Train Unavailability,” the definition for “Train unavailable hours” [Page F-5, Lines 18 to 22] states:

*“Train unavailable hours: The hours the train was not able to perform its monitored function while critical. Fault exposure hours are not included; unavailable hours are counted only for the time required to recover the train’s monitored functions. In all cases, a train that is considered to be OPERABLE is also considered to be available. Unavailability must be by train; do not use average unavailability for each train because trains may have unequal risk weights.”*

This definition and the definitions of “failures” in Section F.2.2.2 do not address the “return to service” question posed above.

**Response**

Effective 7/11/2010



FAQs - By Cornerstone/PI

Mitigating Systems

MS06 MS07 MS08 MS09 MS10

Number	Cornerstone	PIs	Date Entered
--------	-------------	-----	--------------

**Proposed Resolution of FAQ**

Incorporate the following recommended changes into the next revision to NEI 99-02. The changes are effective April 1, 2010 for data that is to be reported on July 21, 2010.

**Proposed Rewording of guidance for inclusion in the next revision of NEI 99-02:**

Revise F.1.2.1, Page F-5, Lines 18 to 22] to read:

*“Train unavailable hours: The hours the train was not able to perform its monitored function while critical. Fault exposure hours are not included; unavailable hours are counted only for the time required to recover the train’s monitored functions. In all cases, a train that is considered to be OPERABLE is also considered to be available. Trains that are not Operable must be returned to service in order to be considered available. Unavailability must be by train; do not use average unavailability for each train because trains may have unequal risk weights.*

*Return to Service: Return to service is the transition from unavailable to available. A train is “returned to service” when the following conditions are met: clearance tags have been removed, the train has been aligned and prepared for operation, (e.g., valve line-up complete, system filled and vented), further adjustment of associated equipment is not required or expected as the result of the unavailability period, and operators concur that the train is able to perform its expected functions. For standby equipment, automatic functions are aligned or can be promptly restored by an operator consistent with the requirements for crediting operator recovery stated later in this section.”*

Revise F.1.2.1, Page F-6, Line 38 to F-7, Line 9, to read:

“Credit for Operator Recovery Actions to Restore the Monitored Functions

## FAQs - By Cornerstone/PI

### Mitigating Systems

MS06 MS07 MS08 MS09 MS10

Number	Cornerstone	PIs	Date Entered
--------	-------------	-----	--------------

1. During testing, operational alignment *or return to service*:

Unavailability of a monitored function during testing, operational alignment *or return to service* need not be included if the test or operational alignment configuration is automatically overridden by a valid starting signal, or the function can be promptly restored either by an operator in the control room or by a designated operator<sup>10</sup> stationed locally for that purpose. Restoration actions must be contained in a written procedure, <sup>11</sup> must be uncomplicated (a single action or a few actions), must be capable of being restored in time to satisfy PRA success criteria, and must not require diagnosis or repair. Credit for ...”

Revise F.2.2.2, Page F-26, Lines 3 to 31, to read:

*“EDG failure to start:* A failure to start includes those failures up to the point the EDG has achieved required speed and voltage. (Exclude post maintenance tests (PMTs), unless the cause of failure was independent of the maintenance performed. Include all failures that result from a non-PMT demand following return to service. If a PMT failure occurs following return to service and was dependent on the maintenance performed, then this failure is excluded and the train, during the period from the completion of the maintenance activity to the declaration of return to service, is counted as unavailable.)

*EDG failure to load/run:* Given that it has successfully started, a failure of the EDG output breaker to close, to successfully load sequence and to run/operate for one hour to perform its monitored functions. This failure mode is treated as a demand failure for calculation purposes (Exclude post maintenance tests, unless the cause of failure was independent of the maintenance performed. Include all failures that result from a non-PMT demand following return to service. If a PMT failure occurs following return to service and was dependent on the maintenance performed, then this failure is excluded and the train, during the period from the completion of the maintenance activity to the declaration of return to service, is counted as unavailable.)

*EDF failure to run:* Given that it has successfully started and loaded and run for an hour,

## FAQs - By Cornerstone/PI

### Mitigating Systems

MS06 MS07 MS08 MS09 MS10

Number	Cornerstone	PIs	Date Entered	
				<p>a failure of an EDG to run/operate. (Exclude post maintenance tests, unless the cause of failure was independent of the maintenance performed. Include all failures that result from a non-PMT demand following return to service. If a PMT failure occurs following return to service and was dependent on the maintenance performed, then this failure is excluded and the train, during the period from the completion of the maintenance activity to the declaration of return to service, is counted as unavailable.)</p> <p><i>Pump failure on demand:</i> A failure to start and run for at least one hour is counted as failure on demand. (Exclude post maintenance tests, unless the cause of failure was independent of the maintenance performed. Include all failures that result from a non-PMT demand following return to service. If a PMT failure occurs following return to service and was dependent on the maintenance performed, then this failure is excluded and the train, during the period from the completion of the maintenance activity to the declaration of return to service, is counted as unavailable.)</p> <p><i>Pump failure to run:</i> Given that it has successfully started and run for an hour, a failure of a pump to run/operate. (Exclude post maintenance tests, unless the cause of failure was independent of the maintenance performed. <i>Include all failures that result from a non-PMT demand following return to service. If a PMT failure occurs following return to service and was dependent on the maintenance performed, then this failure is excluded and the train, during the period from the completion of the maintenance activity to the declaration of return to service, is counted as unavailable.</i>)</p> <p><i>Valve failure on demand:</i> A failure to transfer to the required monitored state (open, close, or throttle to the desired position as applicable) is counted as failure on demand. (Exclude post maintenance tests, unless the cause of failure was independent of the maintenance performed. Include all failures that result from a non-PMT demand following return to service. If a PMT failure occurs following return to service and was dependent on the maintenance performed, then this failure is excluded and the train, during the period from the completion of the maintenance activity to the declaration of return to service, is counted as unavailable.)</p>

FAQs - By Cornerstone/PI

Mitigating Systems

MS06 MS07 MS08 MS09 MS10

Number	Cornerstone	PIs	Date Entered	
--------	-------------	-----	--------------	--

*Breaker failure on demand: A failure to transfer to the required monitored state (open or close as applicable) is counted as failure on demand (Exclude post maintenance tests, unless the cause of failure was independent of the maintenance performed. Include all failures that result from a non-PMT demand following return to service. If a PMT failure occurs following return to service and was dependent on the maintenance performed, then this failure is excluded and the train, during the period from the completion of the maintenance activity to the declaration of return to service, is counted as unavailable.)”*

FAQs - By Cornerstone/PI

Mitigating Systems

MS06 MS07 MS08 MS09 MS10

Number	Cornerstone	PIs	Date Entered	
468	MS	MS06 MS07 MS08 MS09 MS10	1/21/2010	<p><b><u>Question</u></b>  <b>NEI guidance needing interpretation/revision:</b></p> <p>NEI 99-02, Revision 5, Appendix F, Section F.1.2.1:</p> <p>To address the problem of having too frequent baseline revisions, the staff is proposing to clarify the definition of maintenance program philosophy and the addition of a requirement to ensure that changes in the UA baseline are consistent with the unavailability assumptions contained in the PRA.</p> <p><b>Basis for Revising NEI 99-02, Appendix F, Section f 1.2.1</b></p> <p>Section F1.2.2 states that, “The initial baseline planned unavailability is based on actual plant-specific values for the period 2002 through 2004. (Plant specific values of the most recent data are used so that the indicator accurately reflects deviation from expected planned maintenance.) These values are expected to change if the plant maintenance philosophy is substantially changed with respect to on-line maintenance or preventive maintenance. In these cases, the planned unavailability baseline value should be adjusted to reflect the current maintenance practices, including low frequency maintenance evolutions.” The point of changing the planned unavailability values is to account for philosophy changes to the on-line maintenance or preventive maintenance program.</p> <p>As this UA baseline definition includes all non-failure activities, the concept of making changes to the UA baseline tied solely to the maintenance program philosophy appears to have created inconsistencies in the implementation of maintenance program philosophy changes. It is the staff’s expectation that the performance or condition of the SSCs is effectively controlled by preventive maintenance and testing programs (a maintenance rule expectation). These programs and condition monitoring activities should be periodically evaluated to ensure that the objective of preventing failures of SSCs through maintenance is appropriately balanced against the objective of minimizing unavailability of SSCs. Changes to the maintenance program philosophy</p>

FAQs - By Cornerstone/PI

Mitigating Systems

MS06 MS07 MS08 MS09 MS10

Number	Cornerstone	PIs	Date Entered
--------	-------------	-----	--------------

refer to changes to the preventive maintenance and testing programs. This interpretation is consistent with the definition of Maintenance contained in Regulatory Guide 1.160, "Monitoring the Effectiveness of Maintenance at Nuclear Power Plants." This guidance states: "For the purposes of the maintenance rule, maintenance activities are as described in the "Final Commission Policy Statement on Maintenance of Nuclear Power Plants. This definition is very broad and includes all activities associated with the planning, scheduling, accomplishment, post-maintenance testing, and returning to service activities for surveillances and preventive and corrective maintenance." Other additions of unplanned unavailability, such as equipment modifications, except as discussed below, or responses to degraded conditions, are not considered to be a change in maintenance program philosophy. Changes to baseline unavailability for equipment modifications are allowed only if the modification is consistent with the assumptions in the PRA that were used to develop the MSPI Birnbaum values and are not already reflected in the MSPI UA baseline. That is, the unavailability values contained in the PRA include unavailability hours consistent with those needed for the proposed modification, and current maintenance and testing programs; and the hours in the MSPI UA baseline do not reflect this total unavailability. If the MSPI baseline is adjusted as a result of a modification, the MSPI baseline changes should be removed at the conclusion of the 3-year monitoring period that encompasses the modification.

The initial baseline planned unavailability is based on actual plant-specific values for the period 2002 through 2004 and may not be fully consistent with current practices. However, it is expected that changes to baseline unavailability will reflect the appropriate balancing of preventing failures of SSCs against the objective of minimizing unavailability of SSCs and, as such, the unavailability should not be increasing with time unless a maintenance program philosophy change has been implemented.

**Response**

FAQs - By Cornerstone/PI

Mitigating Systems

MS06 MS07 MS08 MS09 MS10

Number	Cornerstone	PIs	Date Entered
--------	-------------	-----	--------------

**Event or circumstances requiring guidance interpretation:**

Recommended Changes

Change Section F1.2.2 (lines 35 to 41) from:

The initial baseline planned unavailability is based on actual plant-specific values for the period 2002 through 2004. (Plant specific values of the most recent data are used so that the indicator accurately reflects deviation from expected planned maintenance. These values are expected to change if the plant maintenance philosophy is substantially changed with respect to on-line maintenance or preventive maintenance. In these cases, the planned unavailability baseline value should be adjusted to reflect the current maintenance practices, including low frequency maintenance evolutions.)

To:

The initial baseline planned unavailability is based on actual plant-specific values for the period 2002 through 2004. (Plant specific values of the most recent data are used so that the indicator accurately reflects deviation from expected planned maintenance. These values are expected to change if the plant maintenance philosophy is substantially changed with respect to on-line maintenance or preventive maintenance. In these cases, the planned unavailability baseline value should be adjusted to reflect the current maintenance practices, including low frequency maintenance evolutions.) Prior to implementation of an adjustment to the planned unavailability baseline value, the impact of the adjusted values on all MSPI PRA inputs should be assessed. A change to the PRA model and associated changes to the MSPI PRA inputs values is required prior to changing the baseline unavailability if:

$$\Delta CDF > 1E-8$$

Where:

## FAQs - By Cornerstone/PI

### Mitigating Systems

MS06 MS07 MS08 MS09 MS10

Number	Cornerstone	PIs	Date Entered
--------	-------------	-----	--------------

$$\Delta CDF_{\text{baseline}} = \sum(\Delta UA_i * \text{Birnbaur}_i)$$

$$\Delta UA_i = UA_{\text{current}} - UA_{\text{baseline}} \text{ for segment } i$$

$UA_{\text{current}}$  = proposed unavailability (expressed as a probability) to be used as the new baseline

$UA_{\text{baseline}}$  = the base unavailability (expressed as a probability) for 2002 – 2004

$\text{Birnbaur}_i$  = Birnbaum value of segment  $i$

The following changes are considered a “change in plant maintenance philosophy:”

- A change in frequency or scope of a current preventative maintenance activity or surveillance test.
- The addition of a new preventative maintenance activity or surveillance test.
- The occurrence of a periodic maintenance activity at a higher or lower frequency during a three year data window (e.g., a maintenance overhaul that occurs once every 24 months will occur twice 2/3 of the time and once 1/3 of the time). If the unavailability hours required for the additional maintenance activity is included in the PRA modeled unavailability, the baseline unavailability can be changed without further assessment.
- Planned maintenance activities that occur less than once every 3 years (e.g., 5 or 10 year overhauls). If the unavailability hours required for the additional maintenance activity is included in the PRA modeled unavailability, the baseline unavailability can be changed without further assessment.
- The performance of maintenance in response to a condition-based preventive maintenance activity.
- Performance of an on-line modification that has been determined to be consistent with the unavailability values contained in the PRA in that the PRA includes unavailability hours for the proposed modification, and current maintenance and testing programs; and the hours in the MSPI UA baseline do not reflect this total unavailability.



FAQs - By Cornerstone/PI

Mitigating Systems

MS06 MS07 MS08 MS09 MS10

Number	Cornerstone	PIs	Date Entered
--------	-------------	-----	--------------

The following changes are not considered a “change in plant maintenance philosophy:”

- The performance of maintenance in response to a degraded condition (even when it is taken out of service to address the degraded condition) unless this action is in response to a condition-based preventive maintenance activity.
- Planned maintenance activity that exceeds its planned duration.
- The performance of an on-line modification that do not meet the change in plant maintenance philosophy online modification criterion.

Note: Condition-based maintenance consists of periodic preventive maintenance tasks or on-line monitoring of the health or condition of a component (e.g., vibration analysis, oil analysis, MOVAT) and predefined acceptance criteria where corrective action is to be taken on exceeding these criteria. Condition-based maintenance does not include discovery of a degraded condition as a result of actions that are outside of the maintenance programs.

Mitigating Systems  
MS10

482 MS MS10 9/21/2011 **Question**

NEI 99-02, Rev. 6, provides guidance for the cooling water system scope on pages F-52 and F-53. The text from page F-53, lines 2 through 7, highlighted in italics below, indicates that only the last valve in a cooling water system line is included in the boundary of the monitored component. While this may be correct in most applications, there are plant configurations where a cooling water system line running to a monitored system (EDG for example) has more than one isolation valve (e.g., manual isolation valve(s)). If the isolation valve(s) were closed it would only result in supported train unavailability and would not affect the availability of the cooling water system. However, the guidance on page F-53, lines 2 through 7, could lead one to the opposite conclusion and suggest that the cooling water system would be unavailable.

NEI 99-02, Rev. 6, Page F-53, lines 1 through 9:

*Systems that provide this function typically include service water and component cooling water or their cooling water equivalents. Pumps, valves, heat exchangers and line segments that are necessary to provide cooling to the other monitored systems are included in the system scope up to, but not including, the last valve that connects the cooling water support system to components in a single monitored system. This last valve is included in the other monitored system boundary. If the last valve provides cooling to SSCs in more than one monitored system, then it is included in the cooling water support system. Service water systems are typically open "raw water" systems that use natural sources of water such as rivers, lakes or oceans. Component Cooling Water systems are typically closed "clean water" systems.*

**Question** - Should a cooling water system isolation valve(s) in a line supplying a single monitored component be included in the monitored train's system boundary?

The industry and the NRC agree on the issue and question as described above.

**Response**

**Response** – Yes, a cooling water system isolation valve(s) in a line supplying a single

Mitigating Systems

MS10

monitored train should be included in the monitored train's system boundary.

Revise NEI 99-02, Rev. 6, Page F-52, lines 40 through 43, and Page F-53, lines 1 through 9, to read as follows:

The functions monitored for the cooling water support system are those functions that are necessary (i.e. Technical Specification-required) to provide for direct cooling of the components in monitored trains or segments of systems supported by the cooling water system. It does not include indirect cooling provided by room coolers or other HVAC features.

Systems that provide this function typically include service water and component cooling water or their cooling water equivalents. Service water systems are typically open "raw water" systems that use natural sources of water such as rivers, lakes, or oceans. Component cooling water systems are typically closed "clean water" systems.

Pumps, valves, heat exchangers and line segments that are necessary to provide cooling to monitored trains or segments of system(s) supported by the cooling water system are included within the cooling water system boundary up to, but not including, the isolation valve(s) that connects the cooling water system to components in a single monitored train or segment of the supported system. This isolation valve is included within the boundary of the monitored train or segment of the supported system. The last valve(s) that provides cooling to SSCs in more than one monitored train or segment of supported system(s) is included within the boundary of the cooling water system. All valves (e.g., manual isolation valves or motor operated valves) in a cooling water line to a single monitored train or segment of a supported system are included within the boundary of the monitored train or segment of the supported system. Figure F-6 depicts this concept and the treatment of multiple isolation valves. The SSCs outside the dashed boxes are included within the boundary of the cooling water system. The SSCs within the dashed boxes are included within the boundaries of the supported systems.

Mitigating Systems  
MS10

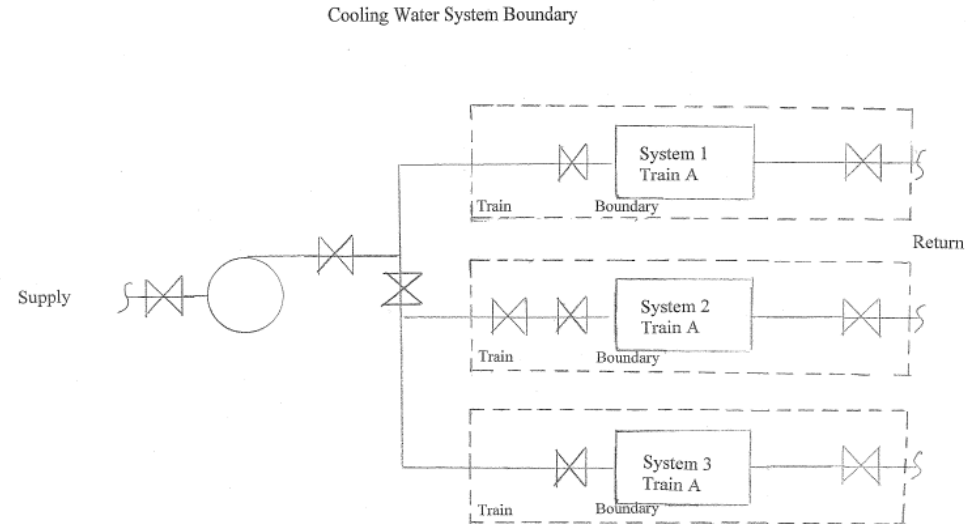

Figure F-6

*NRC Response:*

NRC staff agrees with the proposed resolution. The effective date will be January 1, 2012, meaning that the resolution will begin to be applied to 1Q2012 data that is reported to NRC in April 2012.

FAQs - By Cornerstone/PI

Mitigating Systems  
MS08

Number	Cornerstone	PIs	Date Entered	
479	MS	MS08	5/4/2011	<b>Question</b>

*NEI 99-02 guidance needing interpretation (include page and line criterion):*

Point Beach is requesting a one-time exemption from the PI reporting guidance. Specifically, Point Beach wants to know if it is acceptable to gray out MS08, Heat Removal Systems, for the second quarter of 2011 as the results will not be representative of the current PRA and MSPI Document for the quarter.

Point Beach is requesting approval to characterize MS08 data as follows:

- As the new pumps and associated monitored valves will be similar to the existing pumps and associated monitored valves, is it acceptable to determine the baseline unavailability data (nominally 2002-2004) for the new trains/segments by utilizing the baseline unavailability data for the existing trains/segments, removing the unavailability taken when the other unit was in an outage and averaging the data over three years?
- As the new pumps and associated monitored valves will be similar to the existing pumps and associated monitored valves, is it acceptable to determine the past three years historical unavailability for the new trains/segments by utilizing the data for the existing trains/segments removing the unavailability taken when the other unit was in an outage and averaging the data over three years?
- Is it acceptable to update the device records in CDE at the time the new pumps and associated monitored valves are placed in service and to update the train definition in the MSPI Basis Document at the end of the second quarter of 2011?

Finally, Point Beach wants to know if it is acceptable to revise the generic common cause failure adjustment value in NEI 99-02, Appendix F, Table 7, from 1.25 to 1.0 per this FAQ and to update NEI 99-02 at a later date after the systems are placed in service.

## FAQs - By Cornerstone/PI

### Mitigating Systems

#### MS08

Number	Cornerstone	PIs	Date Entered
--------	-------------	-----	--------------

*Event or circumstances requiring guidance interpretation:*

Point Beach is upgrading the Unit 1 and Unit 2 auxiliary feedwater systems (AF) during the second quarter of 2011 with Unit 2 being completed during the spring outage and Unit 1 while the plant is on line. The current AF design has two motor-driven AF pumps that are shared between the two units. In the current configuration, the operating unit has planned unavailability during the other unit's refueling outage. After the upgrade modifications are completed, the AF system will have one new motor-driven pump dedicated to each unit and will no longer have planned unavailability during the other unit's refueling outage. The new pumps will be the same model casing as the old pumps, but will have a different impeller, resulting in a higher flow rate, and will be powered by 4160V versus 480V. The preventive maintenance activities for the new pumps and associated monitored valves will be essentially the same as those for the existing pumps and associated monitored valves. The change will reduce the number of motor-driven AF trains from two to one per unit and will change the Point Beach generic common cause failure adjustment value from 1.25 to 1.0 in NEI 99-02, Appendix F, Table 7.

The refueling outage is scheduled to be completed during the second quarter of 2011. As the units will be putting the new AF pumps and associated monitored valves in service during the middle of a quarter, the device records in CDE will be updated upon entry into MODE 4 ascending for Unit 2 and when the new AF pump and associated monitored valves are placed in service for Unit 1. However, CDE and the MSPI Basis Document will not be updated until the end of the second quarter to reflect the new PRA and the new train definitions.

The completion of the modification during the middle of a quarter will result in the inability to implement all of the guidance in NEI 99-02 related to reporting of data in CDE. The goal is to provide a second quarter MSPI submittal for AF that accurately reflects the actual availability and reliability of the existing and new AF system configurations and implements the guidance of NEI 99-02 as much as

## FAQs - By Cornerstone/PI

### Mitigating Systems MS08

Number	Cornerstone	PIs	Date Entered
--------	-------------	-----	--------------

reasonable. However, as CDE does not support the submittal of split data and does not allow PRA model changes mid-quarter, an MSPI result for MS08, Heat Removal Systems, reflecting second quarter 2011 AF system unavailability and reliability would not be representative of the new system and would not provide meaningful results. Therefore, the exemptions above from NEI 99-02 guidance are requested for Point Beach based upon the system design changes being implemented in the second quarter of 2011.

*If licensee and NRC resident/region do not agree on the facts and circumstances, explain:*

The licensee and the NRC agree on the facts.

*Potentially relevant existing FAQ numbers:*

None

#### **Response**

#### Resolution

Point Beach may have a one-time exemption from the reporting guidance on Page 2, Lines 15 23, of NEI 99-02, Revision 6. The 2Q2011 MS08 PI will be characterized as “Insufficient Data to Calculate PI,” as indicated by:

I

on the NRC’s “ROP Performance Indicators Summary” Web site because (1) the results will not be representative of the current PRA and MSPI Basis Document for that quarter and (2) the data reflecting the actual plant configuration cannot be processed in CDE software. A comment shall be added to the CDE submittal file explaining the basis for this characterization, which will include that the modification was installed mid-quarter, CDE is not capable of processing a “data split” within the same quarter,

## FAQs - By Cornerstone/PI

### Mitigating Systems MS08

Number	Cornerstone	PIs	Date Entered	
				<p>CDE does not allow mid-quarter PRA model changes, and an MSPI result for MS08, Heat Removal Systems, reflecting 2Q2011 AF system unavailability and reliability would not be representative of the new system nor provide meaningful results.</p>
				<p>AF unavailability and reliability data will be reported to the NRC for 2Q2011. The data will be used for assessing MS08 data for subsequent quarters.</p>
				<p>Because the new pumps and associated monitored valves will be similar to the existing pumps and associated monitored valves, Point Beach will determine the baseline unavailability data (nominally 2002-2004) for the new trains by using the unavailability data for the existing trains, removing the unavailability that was reported when the other unit was in an outage, and averaging the data over three years. With respect to historical unavailability data, because the new pumps and associated monitored valves will be similar to the existing pumps and associated monitored valves, Point Beach will determine the past three years of historical unavailability for the new trains by using the data for the existing trains, removing the unavailability taken when the other unit was in an outage, and averaging the data over three years. Point Beach will also update the MSPI basis document at the end of 2Q2011 to reflect the modification's impact on system and train boundaries.</p>
				<p>With respect to reliability data, Point Beach will update the device records and associated reliability data in CDE at the time the new pumps and associated monitored valves are placed in service and will update the MSPI basis document at the end of 2Q2011 to reflect the modification's impact on monitored component boundaries. The most recent three years of reliability data for the currently installed pumps will serve as the reliability data for the new pumps because of their similar design and function.</p>
				<p>It is acceptable to revise the HRS/MDP Standby generic common cause failure adjustment value from 1.25 to 1.00, which will take effect upon the implementation of the modification, in NEI 99-02, Revision 6, Appendix F, Table 7.</p>
				<p><b>The following text will be added to Appendix D to NEI 99-02:</b></p>



## FAQs - By Cornerstone/PI

### Mitigating Systems

#### MS08

Number	Cornerstone	PIs	Date Entered
--------	-------------	-----	--------------

Issue: Point Beach is upgrading the Unit 1 and Unit 2 auxiliary feedwater systems (AF) during the second quarter of 2011 with Unit 2 being completed during the spring outage and Unit 1 while the plant is on line. The current AF design has two motor-driven AF pumps that are shared between the two units. In the current configuration, the operating unit has planned unavailability during the other unit's refueling outage. After the upgrade modifications are completed, the AF system will have one new motor-driven pump dedicated to each unit and will no longer have planned unavailability during the other unit's refueling outage. The new pumps will be the same model casing as the old pumps, but will have a different impeller, resulting in a higher flow rate, and will be powered by 4160V versus 480V. The preventive maintenance activities for the new pumps and associated monitored valves will be essentially the same as those for the existing pumps and associated monitored valves. The change will reduce the number of motor-driven AF trains from two to one per unit and will change the Point Beach generic common cause failure adjustment value from 1.25 to 1.0 in NEI 99-02, Appendix F, Table 7.

The refueling outage is scheduled to be completed during the second quarter of 2011. As the units will be putting the new AF pumps and associated monitored valves in service during the middle of a quarter, the device records in CDE will be updated upon entry into MODE 4 ascending for Unit 2 and when the new AF pump and associated monitored valves are placed in service for Unit 1. However, CDE and the MSPI Basis Document will not be updated until the end of the second quarter to reflect the new PRA and the new train definitions.

The completion of the modification during the middle of a quarter will result in the inability to implement all of the guidance in NEI 99-02 related to reporting of data in CDE. The goal is to provide a second quarter MSPI submittal for AF that accurately reflects the actual availability and reliability of the existing and new AF system configurations and implements the guidance of NEI 99-02 as much as reasonable. However, as CDE does not support the submittal of split data and

## FAQs - By Cornerstone/PI

### Mitigating Systems MS08

Number	Cornerstone	PIs	Date Entered
--------	-------------	-----	--------------

does not allow PRA model changes mid-quarter, an MSPI result for MS08, Heat Removal Systems, reflecting second quarter 2011 AF system unavailability and reliability would not be representative of the new system and would not provide meaningful results. Therefore, exemptions from NEI 99-02 reporting guidance are requested for Point Beach based upon the system design changes being implemented in the second quarter of 2011.

#### Resolution

Point Beach may have a one-time exemption from the reporting guidance on Page 2, Lines 15 23, of NEI 99-02, Revision 6. The 2Q2011 MS08 PI will be characterized as “Insufficient Data to Calculate PI,” as indicated by:

I

on the NRC’s “ROP Performance Indicators Summary” Web site because (1) the results will not be representative of the current PRA and MSPI Basis Document for that quarter and (2) the data reflecting the actual plant configuration cannot be processed in CDE software. A comment shall be added to the CDE submittal file explaining the basis for this characterization, which will include that the modification was installed mid-quarter, CDE is not capable of processing a “data split” within the same quarter, CDE does not allow mid-quarter PRA model changes, and an MSPI result for MS08, Heat Removal Systems, reflecting 2Q2011 AF system unavailability and reliability would not be representative of the new system nor provide meaningful results.

AF unavailability and reliability data will be reported to the NRC for 2Q2011. The data will be used for assessing MS08 data for subsequent quarters.

Because the new pumps and associated monitored valves will be similar to the existing pumps and associated monitored valves, Point Beach will determine the baseline unavailability data (nominally 2002-2004) for the new trains by using the

FAQs - By Cornerstone/PI

Mitigating Systems  
MS08

Number	Cornerstone	PIs	Date Entered
--------	-------------	-----	--------------

unavailability data for the existing trains, removing the unavailability that was reported when the other unit was in an outage, and averaging the data over three years. With respect to historical unavailability data, because the new pumps and associated monitored valves will be similar to the existing pumps and associated monitored valves, Point Beach will determine the past three years of historical unavailability for the new trains by using the data for the existing trains, removing the unavailability taken when the other unit was in an outage, and averaging the data over three years. Point Beach will also update the MSPI basis document at the end of 2Q2011 to reflect the modification's impact on system and train boundaries.

With respect to reliability data, Point Beach will update the device records and associated reliability data in CDE at the time the new pumps and associated monitored valves are placed in service and will update the MSPI basis document at the end of 2Q2011 to reflect the modification's impact on monitored component boundaries. The most recent three years of reliability data for the currently installed pumps will serve as the reliability data for the new pumps because of their similar design and function

It is acceptable to revise the HRS/MDP Standby generic common cause failure adjustment value from 1.25 to 1.00, which will take effect upon the implementation of the modification, in NEI 99-02, Revision 6, Appendix F, Table 7.

*NRC Response to FAQ:*

NRC staff agrees with the proposed changes.

FAQs - By Cornerstone/PI

Mitigating Systems

MS06

**Final Resolution to  
FAQ 10-06, Cascaded Unavailability**

**Plant:** Generic  
**Date of Event:** N/A  
**Submittal Date:** Proposed as 5/4/11  
**Licensee Contact:** Roy Linthicum, 630-657-3846, roy.linthicum@exeloncorp.com  
**NRC Contact:** TBD  
**Performance Indicator:** Mitigating Systems  
**Site Specific FAQ:** No  
**FAQ requested to become effective:** 4/01/2012

**Question Section:**

Clarification in the guidance is needed for what constitutes cascaded unavailability. NEI 99-02 section 2.2, Mitigating System Performance Index, pages 31-36, provide the guidance on how to properly administer and report this performance indicator. On page 34, under the Monitored Systems section, line 37 states explicitly “No support systems are to be cascaded onto the monitored systems, e.g., HVAC room coolers, DC power, Instrument Air, etc.”

Appendix F section 2.1.3 provides guidance on how to define the boundaries of frontline system monitored components and support system components for the Unreliability element of MSPI. While this guidance could reasonably be extended to the unavailability section, there are no explicit statements regarding the definition of boundaries between frontline systems and support systems in the Unavailability element of MSPI.

Additional guidance/clarification should be provide to define the frontline system and support system boundaries for the unavailability element of MSPI to ensure the “no cascading of unavailability” clause is met and unavailability is accurately reported?

**Guidance needing clarification/interpretation:**

Appendix F, section 1.2.1 regarding the establishment of boundaries between frontline and support system components for reporting unavailability should be revised to be consistent with the “No cascading of unavailability” clause from page 34.

Page F-6 "No Cascading of Unavailability" section should be clarified. Currently, all examples in this section refer to disabling a function of a monitored piece of equipment for protection when a support system is out of service. This could lead to an interpretation that these examples are the only conditions applicable to the “no cascading clause” on page 34.

Page F-29 "Failures and Discovered Conditions of Non-Monitored Structures, Systems, and Components" should be revised to be consistent with the guidance of page 34 for no cascading of support systems onto monitored systems, specifically lines 20 – 23 ... "An example could be a manual suction isolation valve left closed which would have caused a pump to fail. This would

**Final Resolution to  
FAQ 10-06, Cascaded Unavailability**

not be counted as a failure of the pump. Any mis-positioning of the valve that caused the train to be unavailable would be counted as unavailability from the time of discovery." This example does not indicate whether the mis-positioned valve was inside or outside the monitored system boundary, which introduces confusion. This example should include a statement that the mis-positioned valve is inside the monitored system boundary.

**Event requiring guidance interpretation:** N/A

**NRC Resident Inspector Position:** TBD

**If licensee and NRC resident/region do not agree on the facts and circumstances explain:** NA

**Potentially relevant existing FAQ numbers:** NA

Response Section:

**Proposed Resolution of FAQ:**

The following guidance changes should be made to NEI 99-02.

**Licensee proposed wording changes:**

Page 31 (existing):

*Unavailability* is the ratio of the hours the train/system was unavailable to perform its monitored functions (as defined by PRA success criteria and mission times) due to planned and unplanned maintenance or test during the previous 12 quarters while critical to the number of critical hours during the previous 12 quarters.

Page 31 (revised):

*Unavailability* is the ratio of the hours the train/system was unavailable to perform its monitored functions (as defined by the train/system boundaries, PRA success criteria and mission times) due to planned and unplanned maintenance or test during the previous 12 quarters while critical to the number of critical hours during the previous 12 quarters.

Page 33 (existing):

**Definition of Terms**

***Risk Significant Functions:*** those at power functions, described in the Appendix F section "Additional Guidance for Specific Systems," that were determined to be risk-significant in accordance with NUMARC 93-01, or NRC approved equivalents (e.g., the STP exemption request). The risk significant system functions described in Appendix F, "Additional Guidance for Specific Systems" should be modeled in the plant's PRA/PSA. System and equipment performance requirements for performing the risk significant functions are determined from the PRA success criteria for the system.

**Final Resolution to  
FAQ 10-06, Cascaded Unavailability**

Page 33 (revised):

**Definition of Terms**

***Risk Significant Functions:*** those at power functions, described in the Appendix F section “Additional Guidance for Specific Systems,” that were determined to be risk-significant in accordance with NUMARC 93-01, or NRC approved equivalents (e.g., the STP exemption request). The risk significant system functions described in Appendix F, “Additional Guidance for Specific Systems” should be modeled in the plant’s PRA/PSA. System and equipment performance requirements for performing the risk significant functions are determined from the PRA success criteria, mission times, and boundaries for the system.

Page 34 (existing):

***Monitored Systems***

Systems have been generically selected for this indicator based on their importance in preventing reactor core damage. The systems include the principal systems needed for maintaining reactor coolant inventory following a loss of coolant accident, for decay heat removal following a reactor trip or loss of main feedwater, and for providing emergency AC power following a loss of plant off-site power. One support function (cooling water support system) is also monitored. The cooling water support system monitors the cooling functions provided by service water and component cooling water, or their direct cooling water equivalents, for the four front-line monitored systems. No support systems are to be cascaded onto the monitored systems, e.g., HVAC room coolers, DC power, instrument air, etc.

Page 34 (revised):

***Monitored Systems***

Systems have been generically selected for this indicator based on their importance in preventing reactor core damage. The systems include the principal systems needed for maintaining reactor coolant inventory following a loss of coolant accident, for decay heat removal following a reactor trip or loss of main feedwater, and for providing emergency AC power following a loss of plant off-site power. One support function (cooling water support system) is also monitored. The cooling water support system monitors the cooling functions provided by service water and component cooling water, or their direct cooling water equivalents, for the four front-line monitored systems. Other support systems (e.g., HVAC room coolers, DC power, instrument air, etc.) will not be cascaded onto the monitored systems’ unavailability or reliability data. For the purposes of MSPI, a failure of a support system component that is outside the system and train boundary of a monitored system will not result in unavailability of a monitored train or failure of a monitored component.

Page F-1 (existing):

***F.1.1.1 Monitored Functions and System Boundaries***

The first step in the identification of system trains is to define the monitored functions and system boundaries. Include all components within the system boundary that are required to satisfy the monitored functions of the system.

**Final Resolution to  
FAQ 10-06, Cascaded Unavailability**

Page F-1 (revised):

***F.1.1.1 Monitored Functions and System Boundaries***

The first step in the identification of system trains is to define the monitored functions and system boundaries. Include all components within the system boundary that are required to satisfy the monitored functions of the system.

The cooling water support system is a system that is calculated separately in MSPI; however, trains/segments of other support systems (e.g., HVAC room coolers, DC power, instrument air, etc.) that may be needed to satisfy a monitored function are not monitored in MSPI for unavailability if the components within those trains/segments are not included within the boundary of a monitored train/segment or the supported system.

Additional guidance for determining the impact on availability and unreliability from unmonitored component failures can be found in Section F.2.2.2.

Page F-2 (existing)

System Interface Boundaries

For water connections from systems that provide cooling water to a single component in a monitored system, the final connecting valve is included in the boundary of the frontline system rather than the cooling water system. For example, for service water that provides cooling to support an AFW pump, only the final valve in the service water system that supplies the cooling water to the AFW system is included in the AFW system scope. This same valve is not included in the cooling water support system scope. The equivalent valve in the return path, if present, will also be included in the frontline system boundary.

Page F-2 (Revised)

System Interface Boundaries

For water connections from systems that provide cooling water to a single component in a monitored system, the final connecting valve is included in the boundary of the frontline system rather than the cooling water system. For example, for service water that provides cooling to support an AFW pump, only the final valve in the service water system that supplies the cooling water to the AFW system is included in the AFW system scope. This same valve is not included in the cooling water support system scope. The equivalent valve in the return path, if present, will also be included in the frontline system boundary.

The impact of room cooling or other related HVAC supports is excluded from the system/train boundary. Unavailability of these systems/components is not counted as unavailability of a monitored system/train. The only exception to this are EDG ventilation systems that have a shared function of both providing room cooling/ventilation that also provide a flow path EDG combustion or exhaust. In these cases, unavailability of components that result in unavailability of EDG due to not having a combustion or exhaust flow path is included in EDG unavailability.

For control functions and electrical power, the system/train boundary includes all system dedicated relays, controllers, and contactors that support the monitored system functions, and all dedicated voltage supply breakers (both motive and control power) and their associated control



**Final Resolution to  
FAQ 10-06, Cascaded Unavailability**

circuits (relay contacts for normally auto actuated components, control board switches for normally operator actuated components). If a relay, breaker, or contactor exists solely to support the operation of a monitored train/segment, it should be considered part of the train's/segment's boundary. If a relay, breaker, or contactor supports multiple trains/segments, it should not be considered as part of the monitored train's/segment's boundary. For turbine driven pumps, the system/train boundary includes the associated control system (relay contacts for normally auto actuated components, control board switches for normally operator actuated components), the control valve, and its voltage supply breaker. Failure or unavailability of components outside of the system/train boundary is **not** counted as unavailability of the impacted system/train.

Page F-2 (existing):

Water Sources and Inventory

Water tanks are not considered to be monitored components. As such, they do not contribute to URI. However, periods of insufficient water inventory contribute to UAI if they result in loss of the monitored train function for the required mission time. If additional water sources are required to satisfy train mission times, only the connecting active valve from the additional water source is considered as a monitored component for calculating UAI. If there are valves in the primary water source that must change state to permit use of the additional water source, these valves are considered monitored and should be included in UAI for the system.

Page F-2 (revised):

Water Sources and Inventory

Water tanks are not considered to be monitored components. As such, they do not contribute to URI. However, since tanks can be in the train boundary, periods of insufficient water inventory contribute to UAI if they result in loss of the monitored train function for the required mission time. If additional water sources are required to satisfy train mission times, only the connecting active valve from the additional water source is considered as a monitored component for calculating UAI. If there are valves in the primary water source that must change state to permit use of the additional water source, these valves are considered monitored and should be included in UAI for the system.

Page F-5 (existing):

*Unplanned unavailable hours:* These hours include elapsed time between the discovery and the restoration to service of an equipment failure or human error (such as a misalignment) that makes the train unavailable. Time of discovery of a failed monitored component is when the licensee determines that a failure has occurred or when an evaluation determines that the train would not have been able to perform its monitored function(s). In any case where a monitored component has been declared inoperable due to a degraded condition, if the component is considered available, there must be a documented basis for that determination, otherwise a failure will be assumed and unplanned unavailability would accrue. If the component is degraded but considered operable, timeliness of completing additional evaluations would be addressed through the inspection process. Unavailable hours to correct discovered conditions that render a monitored component incapable of performing its monitored function are counted as unplanned unavailable hours. An example of this is a condition discovered by an operator on rounds, such as an obvious oil leak, that was determined to have resulted in the equipment being non-functional even though no demand or failure actually occurred. Unavailability due to mis-

**Final Resolution to  
FAQ 10-06, Cascaded Unavailability**

positioning of components that renders a train incapable of performing its monitored functions is included in unplanned unavailability for the time required to recover the monitored function.

Page F-5 (revised):

*Unplanned unavailable hours:* These hours include elapsed time between the discovery and the restoration to service of an equipment failure or human error (such as a misalignment) that makes the train unavailable. Time of discovery of a failed monitored component is when the licensee determines that a failure has occurred or when an evaluation determines that the train would not have been able to perform its monitored function(s). In any case where a monitored component has been declared inoperable due to a degraded condition, if the component is considered available, there must be a documented basis for that determination, otherwise a failure will be assumed and unplanned unavailability would accrue. If the component is degraded but considered operable, timeliness of completing additional evaluations would be addressed through the inspection process. Unavailable hours to correct discovered conditions that render a monitored train incapable of performing its monitored function are counted as unplanned unavailable hours. An example of this is a condition discovered by an operator on rounds, such as an obvious oil leak, that was determined to have resulted in the equipment being non-functional even though no demand or failure actually occurred. Unavailability due to mis-positioning of components that renders a train incapable of performing its monitored functions is included in unplanned unavailability for the time required to recover the monitored function.

Page F-6 (existing):

*No Cascading of Unavailability:* In some cases plants will disable the autostart of a supported monitored system when the support system is out of service. For example, a diesel generator may have the start function inhibited when the service water system that provides diesel generator cooling is removed from service. This is done for the purposes of equipment protection. This could be accomplished by putting a supported system in "maintenance" mode or by pulling the control fuses of the supported component. If no maintenance is being performed on a supported component and it is only disabled for equipment protection due to a support system being out of service, no unavailability should be reported for the train/segment. If, however, maintenance is performed on the monitored component, then the unavailability must be counted.

For example, if an Emergency Service Water train/segment is under clearance, and the autostart of the associated High Pressure Safety Injection (HPSI) pump is disabled, there is no unavailability to be reported for the HPSI pump. If a maintenance task to collect a lube oil sample is performed and it can be performed with no additional tag out, no unavailability has to be reported for the HPSI pump. If however, the sample required an additional tag out that would make the HPSI pump unavailable, then the time that the additional tag out was in place must be reported as planned unavailable hours for the HPSI pump.

Page F-6 (revised):

*No Cascading of Unavailability:* The failure or unavailability of an SSC that is not within the boundary of the monitored MSPI system that it supports does not cause the supported monitored system to accrue unavailability. Although such a failure or condition may require a monitored train or segment of the supported system to be declared inoperable, the monitored train or

**Final Resolution to  
FAQ 10-06, Cascaded Unavailability**

segment of the supported system would not accrue unavailability. If the monitored component of the supported system is rendered non-functional through tag out or physical plant conditions (other than as discussed below), then unavailable time should be accrued for the monitored train or segment of the supported system. Otherwise, unavailability is not accrued.

Plants will sometimes disable the autostart of a supported monitored system when its support system is out of service. For example, a diesel generator may have the start function inhibited when the service water system that provides diesel generator cooling is removed from service. This is done for the purposes of equipment protection. This could be accomplished by putting a supported system's monitored train/segment in "maintenance" mode or by pulling the control fuses of the supported monitored component. If no maintenance is being performed on a component that's within a supported system's monitored train/segment, and the supported system's train/segment is only unavailable because of a monitored support system being out of service, no unavailability should be reported for the supported system's train/segment. If, however, maintenance is performed on the supported system's monitored train/segment, then the unavailability must be counted.

For example, if an Emergency Service Water (ESW) train/segment (i.e., a monitored support system train/segment) is unavailable, and the autostart of the associated High Pressure Safety Injection (HPSI) pump (a monitored supported system) is disabled, there is no unavailability to be reported for the HPSI pump; however, the ESW train/segment does accrue unavailability. If a maintenance task to collect a lube oil sample is performed and it can be performed with no additional tag out, no unavailability has to be reported for the HPSI pump. If however, the sample required an additional tag out that would make the HPSI pump unavailable, then the time that the additional tag out was in place must be reported as planned unavailable hours for the HPSI pump.

Page F-29 (existing):

Failures and Discovered Conditions of Non-Monitored Structures, Systems, and Components (SSC)

Failures of SSCs that are not included in the performance index will not be counted as a failure or a demand. Failures of SSCs that would have caused an SSC within the scope of the performance index to fail will not be counted as a failure or demand. An example could be a manual suction isolation valve left closed which would have caused a pump to fail. This would not be counted as a failure of the pump. Any mis-positioning of the valve that caused the train to be unavailable would be counted as unavailability from the time of discovery. The significance of the mis-positioned valve prior to discovery would be addressed through the inspection process. (Note, however, in the above example, if the shut manual suction isolation valve resulted in an actual pump failure, the pump failure would be counted as a demand and failure of the pump.)

Failures and Discovered Conditions of Non-Monitored Structures, Systems, and Components (SSC)

**Final Resolution to  
FAQ 10-06, Cascaded Unavailability**

Page F-29 (revised):

Unmonitored components within a monitored train/segment boundary do not contribute to unreliability. If an unmonitored component within a monitored train/segment fails, unreliability is not accrued if the unmonitored component does not cause an actual demand and/or failure of a monitored component within the monitored train/segment. If the unmonitored component causes a monitored component within the monitored train/segment to actually fail when demanded, then the monitored component demand and failure are counted for unreliability. The failure of an unmonitored component within a monitored train/segment can cause unavailability of that train/segment to be counted if the train/segment is rendered unavailable.

Unmonitored components outside a monitored train/segment boundary do not contribute to unreliability of monitored components or to unavailability of the monitored train/segment. If an unmonitored component outside a monitored train/segment fails, unreliability is not accrued regardless whether the unmonitored component causes an actual demand and/or failure of a monitored component. The failure of an unmonitored component outside a monitored train/segment cannot cause unavailability of that train/segment to be counted.

For example, a manual suction isolation valve (an unmonitored component within the train boundary) is left closed, which would have caused a pump to fail. The closed valve would not be counted as a failure of the pump, nor would unavailability be accrued. Any mis-positioning of the valve that caused the train to be unavailable would be counted as unavailability from the time of discovery. The significance of the mis-positioned valve prior to discovery would be addressed through the inspection process. (Note, however, in the above example, if the shut manual suction isolation valve resulted in an actual pump failure, the pump failure would be counted as a demand and failure of the pump and unplanned unavailability would be counted against the appropriate train/segment.)

Page F-50 (revised):

**PWR Auxiliary Feedwater Systems**

**Scope**

The function of the AFW system is to provide decay heat removal via the steam generators to cool down and depressurize the reactor coolant system following a reactor trip. The mitigation of ATWS events with the AFW system is not considered a function to be monitored by the MSPI. (Note, however, that the FV values will include ATWS events).

The function monitored for the indicator is the ability of the AFW system to autostart, take a suction from a water source (typically, the condensate storage tank and if required to meet the PRA success criteria and mission time, from an alternate source), and to inject into at least one steam generator.

The scope of the auxiliary feedwater (AFW) or emergency feedwater (EFW) systems includes the pumps, the condensate storage tank (CST), the components in the flow paths between the pumps and CST, and if required, the valve(s) that connect the alternative water source to the auxiliary feedwater system. The flow path for the steam supply to a turbine driven pump is included from the steam source (main steam lines) to the pump turbine. Pumps included in the

**Final Resolution to  
FAQ 10-06, Cascaded Unavailability**

Technical Specifications (subject to a Limiting Condition for Operation) are included in the scope of this indicator. Some initiating events, such as a feedwater line break, may require isolation of AFW flow to the affected steam generator to prevent flow diversion from the unaffected steam generator. This function should be considered a monitored function if it is required.

NRC Response:

NRC staff agrees with the proposed resolution with an effective date of April 1, 2012, meaning that licensees will begin applying this FAQ resolution to 2Q2012 data reported to NRC in July 2012.

**FAQ 11-08, EDG Failure Mode Definitions**

Plant: Generic

Date of Event: NA

Submittal Date: March 30, 2011

Licensee Contact: Ken Heffner Tel/email: [919-546-5688/ken.heffner@pgnmail.com](mailto:919-546-5688/ken.heffner@pgnmail.com)  
Roy Linthicum Tel/email: [630-657-3846/roy.linthicum@exeloncorp.com](mailto:630-657-3846/roy.linthicum@exeloncorp.com)

NRC Contact: Audrey Klett Tel/email: 301-415-0489

Performance Indicator: MS06

Site-Specific FAQ (Appendix D)? No

FAQ requested to become effective on 10/01/2011 and concurrent with FAQ 11-07.

**Question Section**

NEI 99-02 Guidance needing interpretation (include page and line citation):

The Guidance in question is on page F-26, lines 3 through 15, of NEI 99-02, Revision 6.

Event or circumstances requiring guidance interpretation:

There is no event driving this requested change to the guidance. The existing definitions for EDG Failure to Start, Load/Run, and Run are confusing and somewhat contradictory. Industry is proposing to change the guidance as described below. In addition, the failure definitions are being changed to address inclusion of the EDG Fuel Oil Transfer Pumps/Valves as being within the scope of the EDG super component boundary.

If licensee and NRC resident/region do not agree on the facts and circumstances explain

NA

Potentially relevant existing FAQ numbers

NA

**Response Section**

Proposed Resolution of FAQ

Make the changes to the guidance described below.

If appropriate, provide proposed rewording of guidance for inclusion in next revision.

(Existing) *EDG failure to start*: A failure to start includes those failures up to the point the EDG has achieved required speed and voltage. (Exclude post maintenance tests, unless the cause of failure was independent of the maintenance performed.)

(Proposed) *EDG failure to start*: A failure to start includes those failures up to the point when the EDG output breaker has received a signal to close. Exclude post maintenance tests, unless the

cause of failure was independent of the maintenance performed. See the EDG failure to run definition for treatment of fuel oil transfer pump/valve<sup>[A]</sup> failures.<sup>1</sup>

(Existing) *EDG failure to load/run*: Given that it has successfully started, a failure of the EDG output breaker to close, to successfully load sequence and to run/operate for one hour to perform its monitored functions. This failure mode is treated as a demand failure for calculation purposes. (Exclude post maintenance tests, unless the cause of failure was independent of the maintenance performed.)

(Proposed) *EDG failure to load/run*: Given that the EDG has successfully started and the output breaker has received a signal to close, a failure of the output breaker to close or a failure to run/operate for one hour after breaker closure. The EDG does not have to be fully loaded to count the failure. Failure to load/run also includes failures of the EDG output breaker to re-close following a grid disturbance if the EDG was running paralleled to the grid, provided breaker closure is required by plant design. Exclude post maintenance tests, unless the cause of failure was independent of the maintenance performed. See the EDG failure to run definition for treatment of fuel oil transfer pump/valve failures.<sup>1</sup>

(Existing) *EDG failure to run*: Given that it has successfully started and loaded and run for an hour, a failure of an EDG to run/operate. (Exclude post maintenance tests, unless the cause of failure was independent of the maintenance performed.)

(Proposed) EDG failure to run: A failure after the EDG has successfully started, the output breaker has closed and the EDG has run for an hour after the breaker has closed. The EDG does not have to be fully loaded to count the failure. Exclude post maintenance tests, unless the cause of failure was independent of the maintenance performed. Failures of the EDG fuel oil transfer pump(s)/valve(s) are considered to be EDG failures to run if the failure of the EDG fuel oil transfer pump/valve results in the failure of the EDG to be able to run for 24 hours (e.g., no redundant transfer pump/valve is available<sup>2</sup>, or the redundant pump/valve is disabled in a manner preventing it from performing its intended function). Regardless of when the fuel oil transfer pump/valve(s) fails, this counts as a run failure. In the case where a fuel oil transfer pump/valve(s) failure results in more than 1 EDG to not be able to run for 24 hours, a failure is counted for each affected EDG.<sup>1</sup>

Footnotes to be included in NEI 99-02:

<sup>1</sup>Information Systems Laboratories, Inc. performed a review for the NRC of EDG and FOTP failures to support the changes made to EDG failure definitions in 2011. This report can be found in the NRC's Agencywide Documents Access and Management System (ADAMS) at Accession No. ML11259A101.

<sup>2</sup> In order for a redundant fuel oil transfer pump/valve to be credited in a failure determination, it must either automatically actuate or be able to be manually actuated in the time needed to satisfy

---

<sup>A</sup> The 9/22/2011 change to this FAQ text adds the term "valve" where previously only "pump" appeared. This addition reflects recent information indicating that some plants have gravity-fed day tanks for which a valve fulfills the function ascribed to the Fuel Oil Transfer Pump alone in previous versions of this FAQ. [J. Slider, NEI]

NRC Final Response

the PRA success criteria. If the pump/valve requires manual actuation, indication must be available to alert the operating staff of the need to actuate the pump/valve in in the time required.

*NRC Response:*

NRC staff agrees with the proposed changes with an effective date of January 1, 2012, meaning that licensees will begin applying this FAQ resolution to 1Q2012 data reported to NRC in April 2012.



**NRC Final Response  
FAQ 11-09 (Withdrawn)  
Crystal River-3 Extended Shutdown**

**Plant:** Crystal River Unit 3 (CR-3)  
**Date of Event:** N/A  
**Submittal Date:** June 30, 2011  
**Licensee Contact:** Dennis W. Herrin  
Tel/email: 352.563.4633/Dennis.Herrin@pgnmail.com  
**NRC Contact:** Tom Morrissey (CR-3 SRI)  
Tel/email: 352.795.6486 (x3265)/Thomas.Morrissey@pgnmail.com

**Performance Indicators:**

Unplanned Scrams with Complications (IE04)  
Mitigating System Performance Index (MS06-MS10)

**Site-Specific FAQ (Appendix D)?**     Yes    No

In September 2009, CR-3 was taken off line for a refueling outage and for steam generator replacement. During creation of a construction opening in the Containment Building for steam generator replacement, a delamination was created in Bay 3-4 during tendon de-tensioning activities. In mid-March 2011, final re-tensioning of tendons after concrete repair in Bay 3-4 was suspended while engineers investigated evidence of delamination in Bay 5-6 resulting from the tendon re-tensioning work. CR-3 has been shut down since September 2009 and will continue to be shut down into 2013 and perhaps beyond, depending on the repair methodology to be selected. NEI 99-02 does not contain guidance on how to treat certain performance indicators during periods of extended shutdown, or how to recover after returning the unit to service after an extended shutdown.

Because of the unique conditions of this extended shutdown, CR-3 is requesting approval of this FAQ in accordance with NEI 99-02, Revision 6, page E-1, Lines 18-19:

“3. To request an exemption from the guidance for plant-specific circumstances, such as design features, procedures, or unique conditions.”

**FAQ requested to become effective when approved.**

Request that this FAQ be reviewed on an expedited basis since the CR-3 Service Water System (RW/SW/DC) MSPI performance indicator is currently 62% in the Green Band and declining due to the reduction in critical hours and will cross the green-to-white threshold before reaching an extended shutdown period of three years, without an additional MSPI functional failure.

**Question Section**

**NEI 99-02 Guidance needing interpretation** (include page number and line citation):

Unplanned Scrams with Complications – Clarifying Notes - Page 19  
Mitigating System Performance Index – Clarifying Notes – Pages 33 - 35

**NRC Final Response  
FAQ 11-09 (Withdrawn)  
Crystal River-3 Extended Shutdown**

**Event or circumstances requiring guidance interpretation:**

Unplanned Scrams with Complications (USwC) is defined as the number of unplanned scrams, while the reactor is critical, both manual and automatic, during the previous 4 quarters that require additional operator actions. After being in a condition where a reactor has not been critical for the previous 4 quarters, no opportunities exist for a USwC and further performance indicator reporting has no meaning. Once a unit exits an extended shutdown and the reactor becomes critical, this performance indicator will immediately have meaning.

Mitigating System Performance Index (MSPI) is defined as the sum of changes in a simplified core damage frequency evaluation resulting from differences in unplanned unavailability and unreliability relative to industry standard baseline values. In order to initially implement these new performance indicators, three years of past operational data had to be base loaded into the INPO Consolidated Data Entry System in order to arrive at the first meaningful calculated value. It can be assumed that an extended shutdown lasting greater than three years renders these performance indicators meaningless. An additional concern is that these performance indicators are sensitive to the reduction in critical hours and may actually become meaningless sooner than an extended shutdown period of three years. A final consideration is that although many of the MSPI monitored components are not required to be operable in NO MODE operation and MSPI functional failure opportunities are minimized, any such failure would be unrealistically weighted and could result in crossing the green-to-white performance indicator threshold.

**If licensee and NRC resident/region do not agree on the facts and circumstances, explain:**

The NRC Senior Resident Inspector agrees with the characterizations above.

**Potentially relevant existing FAQ numbers:**

No potentially relevant existing FAQs have been located. A review was performed of NRC-approved FAQs and the current listing of Draft FAQs.

**Response Section:**

**Proposed Resolution of FAQ:**

The licensee will continue to submit MSPI failure data but MSPI values and Unplanned Scrams with Complications (USwC) data will not be displayed on the NRC website because it is not indicative of plant performance. The USwC indicator will go active when the reactor is critical. A decision on how to determine the best way to reintroduce the MSPI values will be determined prior to plant startup.

**If appropriate, provide proposed rewording of guidance for inclusion in next revision.**

No revised wording is being proposed.

At the September 21, 2011, ROP Working Group meeting, the following change to this site-specific FAQ was provided by the industry:

**NRC Final Response  
FAQ 11-09 (Withdrawn)  
Crystal River-3 Extended Shutdown**

**Proposed Resolution of FAQ:**

Incorporate guidance for periods of extended shutdown and its impact on the following performance indicators: Unplanned Scrams with Complications and Mitigating System Performance Index.

If appropriate, provide proposed rewording of guidance for inclusion in next revision. No revised rewording is being proposed. Specific wording deferred to the NEI Task Force. Consider the “Event or circumstances requiring guidance interpretation” described above for inclusion in the next revision.

**NRC Response:**

This site-specific FAQ was not accepted by the NRC for review. The NRC and industry reached consensus at the July 13, 2011 ROP working group meeting that the above-mentioned PIs are not valid. Because the reactor has not been critical for two years, there have been no opportunities for a scram that would count in the USwC indicator. Similarly, the MSPI values are skewed because of the very low number of critical hours in three years. For these reasons, NRC has determined that these PIs no longer provide valid indications of performance. Therefore, the NRC characterized these PIs on the NRC Web site as “Not Applicable” on August 19, 2011. The licensee will continue to submit the PI data to the NRC in accordance with NEI 99-02. The NRC documented this decision in its September 1, 2011, mid-cycle performance review letter to the licensee.

NRC staff and industry agreed on the need to develop generic guidance in NEI 99-02 for (1) determining PI validity during extended shutdowns and (2) establishing PI validity after start-ups. NRC staff provided a draft white paper at the September 21, 2011, ROP Working Group Meeting to initiate this effort. A subsequent generic FAQ should be provided to incorporate guidance into NEI 99-02 for determining and establishing the validity of PIs during an extended shutdown and after a start-up.

**Final NRC Response to  
FAQ 11-12, FitzPatrick Downpowers**

**Plant:** James A. FitzPatrick Nuclear Power Plant  
**Date of Event:** June 7, 2011 & June 9, 2011  
**Submittal Date:** Introduced October 26, 2011  
**Licensee Contact:** Gene Dorman 315-349-6810 / [gdorman@entergy.com](mailto:gdorman@entergy.com)  
**NRC Contact:** Ed Knutson 315-349-6667 / [edward.knutson@nrc.gov](mailto:edward.knutson@nrc.gov)  
**Performance Indicator:** Unplanned Power Changes per 7,000 Critical Hours  
**Site-Specific FAQ (Appendix D):**  YES /  NO  
**FAQ requested to become effective when approved or \_\_\_\_\_.**

**Question**

Downpowers were performed on June 7 & 9, 2011 as a result of marine fouling of the main condenser waterboxes during a maintenance activity.

**NEI 99-02 Rev 6 Guidance**

Page 14; lines 42 – 47

Page 15; lines 1 – 15

Anticipated power changes greater than 20% in response to expected environmental problems (such as accumulation of marine debris, biological contaminants, animal intrusion, environmental regulations, or frazil icing) may qualify for an exclusion from the indicator. The licensee is expected to take reasonable steps to prevent intrusion of animals, marine debris, or other biological growth from causing power reductions. Intrusion events that can be anticipated as a part of a maintenance activity or as part of a predictable cyclic behavior would normally be counted, unless the downpower was planned 72 hours in advance or the event meets the guidance below.

In order for an environmental event to be excluded, any of the following may be applied:

If the conditions have been experienced before and the exhibit a pattern of predictability or periodicity (e.g., seasons, temperatures, weather events, animal, etc.), the station must have a monitoring procedure in place or make a permanent modification to prevent recurrence for the event to be considered for exclusion from the indicator. If monitoring identifies the condition, the licensee must have implemented a proactive procedure (or procedures) to specifically address mitigation of the condition before it results in impact to operation. This procedure cannot be a general Abnormal Operating Procedure (AOP) or Emergency Operating Procedure (EOP) addressing the symptoms or consequences of the condition (e.g., low condenser vacuum); rather it must be a condition-specific that directs actions to be taken to address the specific environmental conditions (e.g., jellyfish, gracilaria, frazil ice, etc.)

**Event or Circumstances**

On June 6, 2011, a first time Preventive Maintenance (PM) activity was performed on the traveling water screens. In order to support the PM, gates were installed in the intake structure to isolate the screen being maintained. Based on prior operating experience at the plant, prior to this activity cleaning of the accessible portions of the intake structure was performed and

**Final NRC Response to  
FAQ 11-12, FitzPatrick Downpowers**

the condition of the condenser was monitored in accordance with Circulating Water System Operating Procedure, OP-4 (Reference 1 in transmittal e-mail) to determine if the condenser was being negatively impacted and a contingency downpower was scheduled for condenser flushing if necessary.

Within 24 hours of installing the gates the condenser water box differential temperature increased to a point where a downpower was initiated to perform a backwashing operation in accordance with Circulating Water System Operating Procedure, OP-4 Section G.6. The initial backwashing operation was conducted on June 7, 2011. Because fouling had been recognized as a possibility when the work was planned, based on past experience with inserting the gates, and contingency plans and monitoring were in place the activity continued. As the PM activity continued, a second backwashing operation was required on June 9, 2011, based on the condenser differential temperature.

The Resident Inspector agrees with the facts of the FAQ but believes that the downpowers should count against the indicator.

**Background:**

Past experience with installing gates in the intake structure has demonstrated that condenser fouling may occur. This has been attributed to changes in the flow characteristics in the forebay resulting in debris in the forebay being transported to the condensers resulting in condenser fouling. In order to minimize the probability of fouling, divers cleaned the accessible portions of the forebays the week before the PM in question was scheduled.

Because past experience with installing flow gates in the intake structure had resulted in biological fouling of the condenser OP-4 was revised to include system monitoring parameters and specific guidance on addressing the fouling. As noted above this guidance is contained in Section G.6 of the procedure. Since fouling of the condenser is not certain and is not absolutely predictable a contingency for down power was included in the weekly work schedule.

The travelling water screens were replaced in 2008 and 2009 to address a problem with cladophora algae in Lake Ontario. Since replacement there has been no carryover observed through the windows on the north side (Lake Ontario side) of the screens. Therefore, debris was thought to have been effectively removed by the sprays.

The travelling water screens have a cement filled boot below the screens that runs down to the intake bay (see Diagram 1 below). Due to this design, the annual PM now includes a boot inspection. It was to support this inspection that the gates were inserted.

The PM work order, MP-036.03 (Reference 2 in transmittal e-mail), includes a step that addresses cleaning of the intake bay. Step 7.8 states, "IF the intake canal is scheduled for cleaning, THEN PRIOR to lowering gates to isolate screen, intake bay must be cleaned of debris that can wash into circulating water pumps and main condensers." The vendor information provided with the new traveling water screens, that was used to develop the PM, did not include any information related to potential build-up of marine debris downstream of the screens. Review of industry Operating Experience did not identify any industry OE relative to this condition.

Based on the need to downpower the unit JAF performed an apparent cause evaluation and determined that the fouling observed was from a previously unidentified source. Based on the design of the boot and the cement, it appears that a low flow area may be forming just past the

**Final NRC Response to  
FAQ 11-12, FitzPatrick Downpowers**

boot. There is a possibility for small debris such as silt, sand, and broken zebra mussel shells to settle in this area south of the screens (pump suction side). In this area, the silt may settle out past the boots and build up to a level to meet up with the process flow. This condition would only take a short period of time to build-up and then would remain in the condition until cleaning could remove the debris.

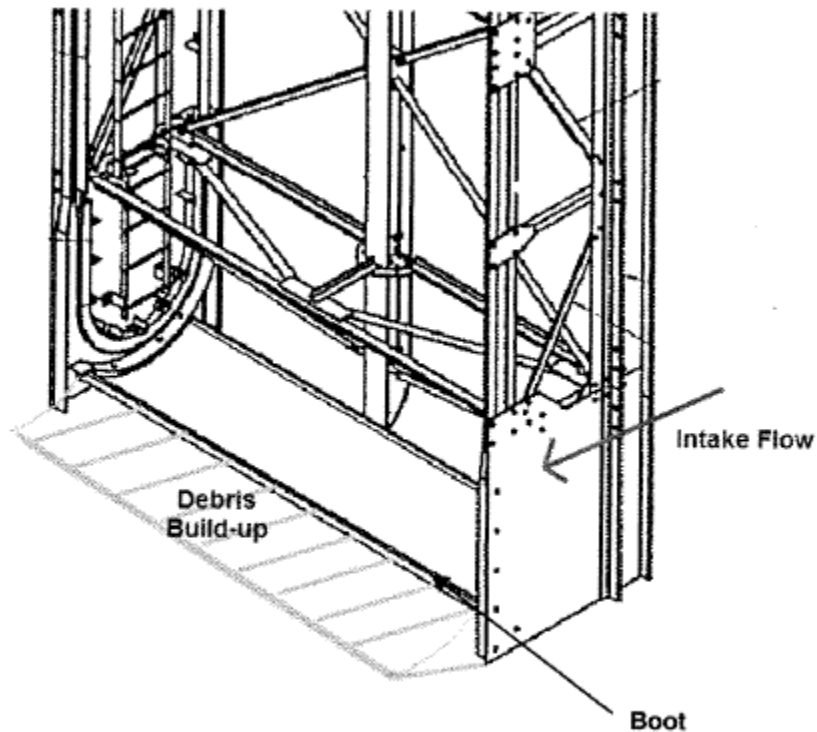

Diagram 1: Low flow area with debris build-up behind Boot

During normal operation, this debris build-up is not a significant threat to fouling because the debris is settled. However, this area becomes vulnerable when the gates are installed because of the change in flow patterns and increased velocity.

As noted above to minimize the impact of the marine debris buildup in the forebay, the annual cleaning and inspection of the intake canals was performed the week prior to the annual PM to inspect the travelling water screen boot. The cleaning included the areas of the forebay from the tempering gate to the trash racks and the area between the trash racks and the screens. However, due to the configuration of the traveling screens, pump bays, and isolation gates (see Diagram 2 below), the area south of the screens was not cleaned because it is not accessible during operation.

During the maintenance activities beginning on 6/6/2011, the south gate was inserted to provide protection for the divers. The installation of the gate caused an increase in flow, which apparently caused the settled debris in the vicinity of the gate to be picked up by localized turbulence, resulting in fouling of the condenser. The apparent cause evaluation postulated

**Final NRC Response to  
FAQ 11-12, FitzPatrick Downpowers**

that the turbulence could be reduced by inserting the gate north of the travelling water screens prior to installing the gate south of the travelling water screens.

Based on the apparent cause evaluation corrective actions have been proposed to  
1) incorporate additional guidance in OP-4, Circulating Water System regarding the sequence for installing gates; and 2) to evaluate the PM task for scheduling optimization.

**Potentially Relevant FAQs**

FAQ #469 – 3/18/2010, Page 19

Anticipated power changes greater than 20% in response to expected environmental problems (such as accumulation of marine debris, biological contaminants, or frazil icing) which are proceduralized but cannot be predicted greater than 72 hours in advance may not need to be counted unless they are reactive to the sudden discovery of off-normal conditions. However, unique environmental conditions which have not been previously experienced and could not have been anticipated and mitigated by procedure or plant modification, may not count, even if they are reactive. The licensee is expected to take reasonable steps to prevent intrusion of marine or other biological growth from causing power reductions. Intrusion events that can be anticipated as part of a maintenance activity or as part of a predictable cyclic behavior would normally be counted unless the down power was planned 72 hours in advance. The circumstances of each situation are different and should be identified to the NRC in a FAQ so that a determination can be made concerning whether the power change should be counted.

**Response**

As stated in NEI 99-02 on page 15 lines 4 – 15 “If the conditions have been experienced before and the exhibit a pattern of predictability or periodicity (e.g., seasons, temperatures, weather events, animal, etc.), the station must have a monitoring procedure in place or make a permanent modification to prevent recurrence for the event to be considered for exclusion from the indicator. If monitoring identifies the condition, the licensee must have implemented a proactive procedure (or procedures) to specifically address mitigation of the condition before it results in impact to operation. This procedure cannot be a general Abnormal Operating Procedure (AOP) or Emergency Operating Procedure (EOP) addressing the symptoms or consequences of the condition (e.g., low condenser vacuum); rather it must be a condition-specific that directs actions to be taken to address the specific environmental conditions (e.g., jellyfish, gracilaria, frazil ice, etc.)”

These downpower events should be excluded from the indicator. The licensee had experienced condenser fouling with the original traveling water screen design and although the travelling water screens had been replaced with a new design that previous operating experience was considered in planning the work on the new screens. The licensee took reasonable steps to prevent intrusion by cleaning the forebays and provided normal operating procedural guidance for monitoring condenser differential temperatures and backwashing the condenser water boxes. Since this was the first time the boot inspections had been performed, there was no way to reasonably anticipate that the debris south of the travelling water screens would have been sufficient to cause the observed condenser fouling. In addition, the on-line schedule for that week had a contingency action to perform a downpower in order to support backwashing activities. This was shown as a contingency because there is no way to accurately predict if the condenser will foul or the speed with which it will reach a point requiring a downpower.

**Final NRC Response to  
FAQ 11-12, FitzPatrick Downpowers**

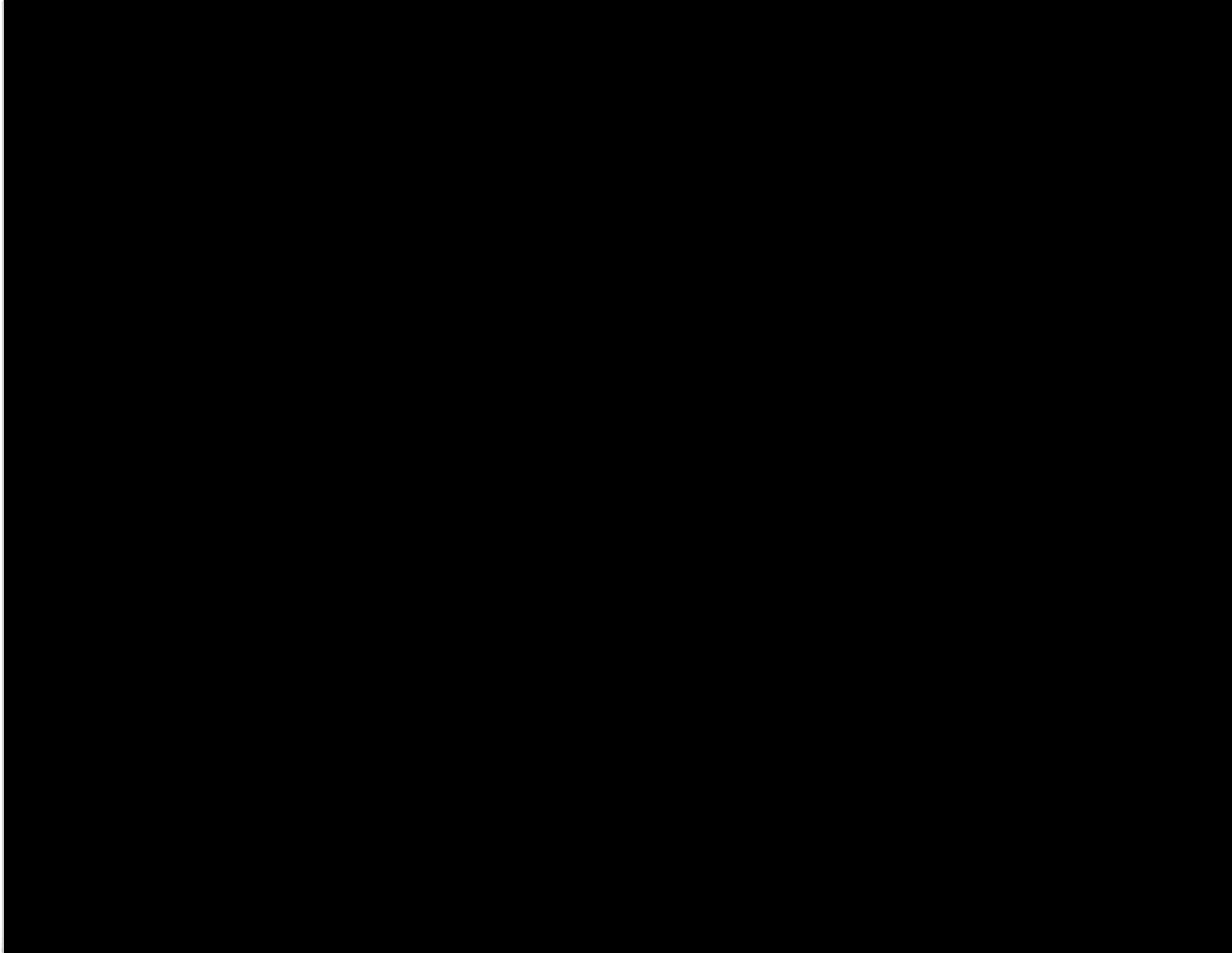

Diagram 2: Simplified Drawing (modified from FM-36A)

**Final NRC Response:**

NEI 99-02, Rev. 6, page 14, beginning with line 36, states, “Intrusion events that can be anticipated as a part of a maintenance activity or as part of a predictable cyclic behavior would normally be counted, unless the downpower was planned 72 hours in advance or the event meets the guidance below.”

Although the licensee may have been aware that condenser fouling during the maintenance or inspection activity could potentially cause a downpower, the licensee was not planning to downpower to conduct the maintenance/inspection. The licensee stated in the FAQ that it could not reasonably anticipate that the debris south of the travelling water screens would have been sufficient to cause the observed condenser fouling. This statement indicates that the licensee was not planning to downpower. Therefore, the staff considers the downpowers to be unplanned.



**Final NRC Response to  
FAQ 11-12, FitzPatrick Downpowers**

NEI 99-02 has guidance for allowing contingency downpowers under certain conditions (page 14, lines 6-8) and anticipatory downpowers in response to certain external events (page 14, lines 38-40) and environmental events (page 14, lines 42-47, and page 15, lines 1 – 29). The external and environmental event guidance reflects situations that are not caused by the licensee and for which the licensee cannot predict or control the timing. Although marine debris is environmental matter, the licensee's action of closing the gates created new flow patterns that transported the debris into the condenser, which has happened at this site in the past. NRC staff does not consider this situation to qualify for the contingency or external or environmental event exclusions in NEI 99-02.

NEI 99-02 also states that the licensee is expected to take reasonable steps to prevent intrusion of animals, marine debris or other biological growth from causing power reductions. Although the licensee cleaned the intake structure area prior to the maintenance, the NRC resident inspector identified licensee condition reports that indicated that several inches of debris were south of the traveling screens some time after installation of the new screens. Based on similar occurrences of this amount of debris causing condenser fouling in the past, the staff believes the condenser fouling could reasonably have been anticipated.

NEI 99-02 states that intrusion events that can be anticipated as a part of a maintenance activity would normally be counted. The staff believes these events could have been anticipated and that the exclusions provided in NEI 99-02 were not applicable. The staff's decision is that the downpowers should have been counted in the PI.

# NRC Final Response to FAQ 11-13

## Suspension of Siren Testing for Weather-related Issues

---

**Plant:** Generic

**Date of Event:** Spring, 2011

**Submittal Date:** 12/01/2011

**Licensee Contact:** Marty Hug **Tel/email:** 202-739-8129/mth@nei.org

**NRC Contact:** Eric Schrader **Tel/email:** 301-415-5627/eric.schrader@nrc.gov

**Performance Indicator:** EP03, Alert and Notification System Reliability

**Site-Specific FAQ (Appendix D)?** No

**FAQ requested to become effective:** At least one full calendar quarter after approval

### Question Section

**NEI 99-02 Guidance needing interpretation (include page and line citation):**

ANS page 57 lines 6 through 10

6 If a siren is out of service for maintenance or is inoperable at the time a regularly scheduled test  
7 is conducted, then it counts as both a siren test and a siren failure. Regularly scheduled tests  
8 missed for reasons other than siren unavailability (e.g., out of service for planned maintenance or  
9 repair) should be considered non opportunities. The failure to perform a regularly scheduled test  
10 should be noted in the comment field.

#### **Event or circumstances requiring guidance interpretation:**

Certain conditions could result in intentional down-powering of equipment for safety reasons (e.g. flooding) and the area being deemed uninhabitable by State and/or Local agencies. In the spring of 2011, flooding on the Missouri River resulted in evacuation of residents around the Fort Calhoun and Cooper nuclear power plants. The plants followed their emergency plans but conditions remained well below a General Emergency which would have required evacuation. Specific areas were evacuated due to high water rather and EPZ sirens in those areas were intentionally de-energized due to rising water and a concern for downed power lines. The sirens were not needed since those areas had already been evacuated. State and local governments identified the areas as inaccessible to the public and uninhabited. Backup route alerting remained available (via water craft). Testing of sirens in areas that are uninhabited would not result in validation of the siren's performance as individuals were not in the areas to report possible failures.

**If licensee and NRC resident/region do not agree on the facts and circumstances explain**

N/A

**Potentially relevant existing FAQ numbers**

None

### Response Section

**Proposed Resolution of FAQ**

Revise Revision 6 of NEI 99-02, page 57, to read as indicated below:

## NRC Final Response to FAQ 11-13

### Suspension of Siren Testing for Weather-related Issues

---

6 If a siren is out of service for maintenance or is inoperable at the time a regularly scheduled test  
7 is conducted, then it counts as both a siren test and a siren failure. Regularly scheduled tests  
8 missed for reasons other than siren unavailability (e.g., out of service for planned maintenance or  
9 repair) should be considered non opportunities. The failure to perform a regularly scheduled test  
10 should be noted in the comment field. ***Additionally, if sirens are not available for operation because of intentional actions to disable them, and the area is deemed uninhabitable by State and/or Local agencies, the siren(s) in question are not required to be counted in the numerator or denominator of the Performance Indicator for testing throughout the event. The conditions causing the suspension of testing, its duration and restoration are to be noted in the comment field for the indicator.***

#### **Final NRC Response:**

NRC staff approves of the proposed revision of NEI 99-02. This change will be effective April 1, 2012 and shall be applied to 2Q2012 data that will be reported to the NRC in July 2012.

**Final NRC Response**  
**FAQ 12-01 Columbia DG3 Failure (Withdrawn)**

**Plant:** Columbia Generating Station (CGS)

**Date of Event:** February 28, 2010

**Submittal Date:** March 6, 2012

**Licensee Contact:** Richard Wolfgramm

Tel/email: (509) 377-4174

rpwolfgramm@energy-northwest.com

**NRC Contact:** Jeremy Groom

Tel/email: (509) 377-2112

jeremy.groom@nrc.gov

**Performance Indicator:** MS06

**Site-Specific FAQ (Appendix D)? Yes or No:** Yes

**FAQ requested to become effective** when approved.

### Question Section

NEI 99-02 Guidance needing interpretation (include page and line citation):

The guidance in question is on page F-26, lines 3 through 15, of NEI 99-02, Rev 6.

3 EDG failure to start: A failure to start includes those failures up to the point the EDG has  
4 achieved required speed and voltage. (Exclude post maintenance tests, unless the cause of failure  
5 was independent of the maintenance performed.)

6

7 EDG failure to load/run: Given that it has successfully started, a failure of the EDG output  
8 breaker to close, **to successfully load sequence and to run/operate for one hour to perform its**  
9 **monitored functions**. This failure mode is treated as a demand failure for calculation purposes.  
10 (Exclude post maintenance tests, unless the cause of failure was independent of the maintenance  
11 performed.)

12

13 EDG failure to run: Given that it has successfully started and loaded and run for an hour, a failure  
14 of an EDG to run/operate. (Exclude post maintenance tests, unless the cause of failure was  
15 independent of the maintenance performed.)

Event or circumstances requiring guidance interpretation:

On February 28, 2010, CGS was testing an Emergency Diesel Generator (EDG). Refer to figure 1 for Load and Current trace of the subject event. The EDG successfully started, the EDG output breaker successfully closed (T = 0 minutes), the EDG successfully load sequenced up to fully loaded (T = 21 minutes), after 45 minutes the EDG experienced unexpected load oscillations of 350 kw (T = 66 minutes), after 17 minutes the load was lowered (T = 83 minutes) and the 350 kw oscillations were observed to continue another 16 minutes of operation until the EDG was unloaded (T = 99 minutes) and shut down.

When the EDG was shutdown, plant staff made a log entry stating, "After running DG3 **fully loaded over an hour** per SOP-DG3-START, observed ... Swings from 300 to 320 amps, Swings from 2200 to 2500 KW ...". Root cause investigation later identified that the governor actuator had failed 45 minutes after reaching full load (T = 66 minutes). At that point the EDG was no longer capable of performing its monitored function. The MSPI Basis Document identifies that the monitored function is to provide 4160 VAC emergency power to safety related Division 3 HPCS equipment and has a mission time of 24 hours. The frequency and magnitude of load oscillations were such that the DG could not have provided power to required safety related loads for 24 hours. To be clear, the EDG did run for more than an hour after breaker closure, but only 45 minutes after reaching full load at which point it was no longer capable of

**Final NRC Response  
FAQ 12-01 Columbia DG3 Failure (Withdrawn)**

performing its monitored function. This was interpreted as an “EDG Failure to Load/Run” based on the guidance in effect at the time and was reported as such.

On October 26, 2011, FAQ Number 487 was issued with an effective date of January 1, 2012, meaning that licensees will begin applying the FAQ resolution to 1Q2012 data reported to NRC in April 2012. The FAQ clarified that the one hour time limit for differentiating between an “EDG Failure to Load/Run” and an “EDG Failure to Run” is after the EDG output breaker successfully closed. The FAQ resolution was needed because the definitions of “EDG Failure to Start”, “EDG Failure to Load/Run”, and “EDG Failure to Run” were confusing and contradictory. Information Systems Laboratories, Inc, performed a review for the NRC of EDG and Fuel Oil Transfer Pump failures to support the changes to the EDG failure definitions. In the report, it specifies that the key differences between NEI 99-02, Rev 6, and the proposed changes includes changes to the load/run failure definition from the failure to successfully load sequence and run/operate for one hour to the failure to run for one hour after breaker has received a signal to close and clarification of run failure to not require the EDG to be fully loaded. The primary objective of the failure definition changes is to sharpen the transition points between the three failure modes.

If licensee and NRC resident/region do not agree on the facts and circumstances explain:

CGS and the CGS NRC Senior Resident Inspector (SRI) do not agree that CGS properly reported the February 28, 2010 EDG failure. NEI 99-02 defines “EDG failure to load/run”. In part, it states: “Given that it has successfully started, a failure of the EDG output breaker to close, to successfully load sequence and to run/operate for **one hour** to perform its monitored functions.” The intent of this FAQ is to clarify that based on the guidance available at the time the start time for the “one hour” period begins once the EDG has completed its load sequence and is loaded (at T=21 and not at T=0 (as per figure 1)). Based on the response to FAQ Number 487, CGS understands that as of 1/1/2012 the “one hour” period begins at output breaker closure (T=0 per figure 1).

**RESIDENT INSPECTOR POSITION**

The inspectors disagree with the licensee’s position that NEI 99-02, Revision 6, in effect at the time the February 28, 2010 diesel failure, would require this issue to be reported as an “EDG failure to load run”. For the February 28, 2010 diesel failure at Columbia Generating Station, please consider the following sequence of events:

Time on 2/28/10	Event	Elapsed Time following DG Output Breaker Closure
1:40 AM	Division 3 Diesel Generator (DG-3) is Started for testing	N/A
1:57 AM	DG-3 Field is Flashed	N/A
2:16 AM	DG-3 Output Breaker is Shut (some load is immediately placed on the component)	T=0
2:37 AM	DG-3 is fully loaded	T + 21 minutes
3:22 AM	DG-3 first exhibits load oscillations	T + 66 minutes
3:55 AM	DG-3 is unloaded	T + 99 minutes
4:36 AM	DG-3 is secured	T + 140 minutes

Based on the timeline associated with the February 28, 2010 diesel failure, the resident inspectors believe that evaluation under the existing guidance at the time of the issue (NEI 99-02, Revision 6) should have determined that this particular diesel failure is an “EDG failure to run”. The two key points

**Final NRC Response**  
**FAQ 12-01 Columbia DG3 Failure (Withdrawn)**

for determining the type of failure should be the time the diesel generator output breaker is closed and the time the monitored function is lost.

The inspectors believe that the 1 hour clock that distinguishes the differences between “failure to load run” and a “failure to run” begins at the time the diesel output breaker is shut (in this case, 2:16 AM). Assigning T=0 at breaker closure as opposed to T=21 when full load is reached is more appropriate in this case because the slow loading sequence used during this particular procedure is not representative of how the component performs its monitored function. The inspectors believe that the definition of failure to load run which includes the phrase “the generator successfully load sequenced” is meant to describe how the equipment would respond in an accident condition (short duration load sequence) rather than the 21 minute slow loading that was performed as part of the standard operating procedure.

NEI 99-02 states that only failures that occur when a component fails to run/operate for one hour to perform its monitored functions should be considered “EDG failure to load/run”. Specifically, NEI 99-02, Revision 6, Page F-26, Lines 7-9 states:

*EDG failure to load/run: Given that it has successfully started, a failure of the EDG output breaker to close, to successfully load sequence and to run/operate for one hour to perform its monitored functions.*

Given this definition, the question becomes “could DG-3 have successfully started, the output breaker closed, the generator successfully load sequenced and the component operated to provide its monitored function for one hour?”

Per the Columbia Generating Station MSPI Basis document, the monitored function of DG-3 is to provide 4160V emergency power to safety related Division 3 high pressure core spray (HPCS) equipment. The diesel run performed on February 28, 2010 does not directly test if DG-3 is capable of providing its monitored function (i.e. power is not provided to HPCS components and the generator is not load sequenced). However, the test that occurred on February 28, 2010 did reveal that if called upon, the engine would start, the diesel output breaker would shut and the engine would load and run for greater than one hour. The failure mechanism (foreign material in the governor) is independent of load and the slow loading sequence used during this particular procedure does not in any way demonstrate the diesel’s ability to perform its monitored function. What is important is that the generator can supply power to the 4160V bus SM-4 which the component demonstrated the moment the output breaker was closed.

Additionally, Energy Northwest’s position that the 1-hour clock starts when the diesel is fully loaded is not consistent with the failure definitions described in NEI 99-02, Revision 6. Specifically, if anything but diesel generator output breaker closure starts the 1-hour clock, then the load/run period would lengthen to something greater than 1-hour. In the case of the February 28, 2010 event, loading of the diesel took approximately 21 minutes, therefore the load/run period would be lengthened to 1 hour and 21 minutes. This is contrary to the NEI 99-02, Revision 6 definition of “EDG failure to load run” which includes only those failures to run/operate for one hour.

Regardless of the time the 1 hour clock started, the resident inspectors believe that this failure should be considered as an “EDG failure to run”. Plant data revealed that at 3:22 AM, DG-3 began to exhibit degraded performance but still provided an average (based on 1 minute average) of >2547 KW which is sufficient to meet all post-accident loads. The diesel engine was allowed to continue to operate until about 3:42 AM when the control room operators logged that after running DG-3 fully loaded for **over an hour** (emphasis added), the component exhibited load swings of 200-300 KW. The component was

**Final NRC Response**  
**FAQ 12-01 Columbia DG3 Failure (Withdrawn)**

secured due to the degraded performance shortly after the operators logged the issue with DG-3. Since the component continued to operate after observing the degraded performance, it is not clear if the monitored function was immediately lost or if the component would have continued to operate for its required mission time. To date, the licensee has not performed an engineering evaluation of the degraded condition to determine at what point the monitored function was lost. The inspectors believe that a strong case can be made that a run failure should be assigned based on NEI 99-02, Revision 6, Page F-28, Lines 28-31

*For a running component that is secured from operation due to observed degraded performance, but prior to failure, then a run failure shall be assumed unless evaluation of the condition shows that the component would have continued to operate for the mission time starting from the time the component was secured.*

**INSPECTOR'S PROPOSED ALTERNATE RESOLUTION**

On February 28, 2010, the DG-3 at Columbia Generating Station started, loaded and ran for greater than one hour and would have been able to perform its monitored function of supplying power to HPCS equipment. After 66 minutes of operation, the engine first exhibited degraded performance. After 86 minutes of operations, the operators determined (as indicated in the control room log) that performance had degraded to the point that there was no longer reasonable assurance the monitored function could still be provided and the engine was secured. Per the guidance in NEI 99-02, Revision 6, as stated above, this failure should be classified as an "EDG failure to run".

Potentially relevant existing FAQ numbers

FAQ Number 487

**Response Section**

Proposed Resolution of FAQ

Based on the guidance available at the time of the event (Feb 2010), the one hour time period referred to in the definition of "EDG failure to load/run" begins once the EDG has successfully load sequenced to fully loaded conditions. Based on the response to FAQ Number 487, given the same event today (after 1/1/2012), the "one hour" time period begins at output breaker closure.

If appropriate, provide proposed rewording of guidance for inclusion in next revision.

None. Proposed wording included under FAQ 487 is clear and it is already our intent to comply with it.

**Final NRC Response  
FAQ 12-01 Columbia DG3 Failure (Withdrawn)**

**Figure 1, Load and current profile during DG3 Operation on 2/28/10**

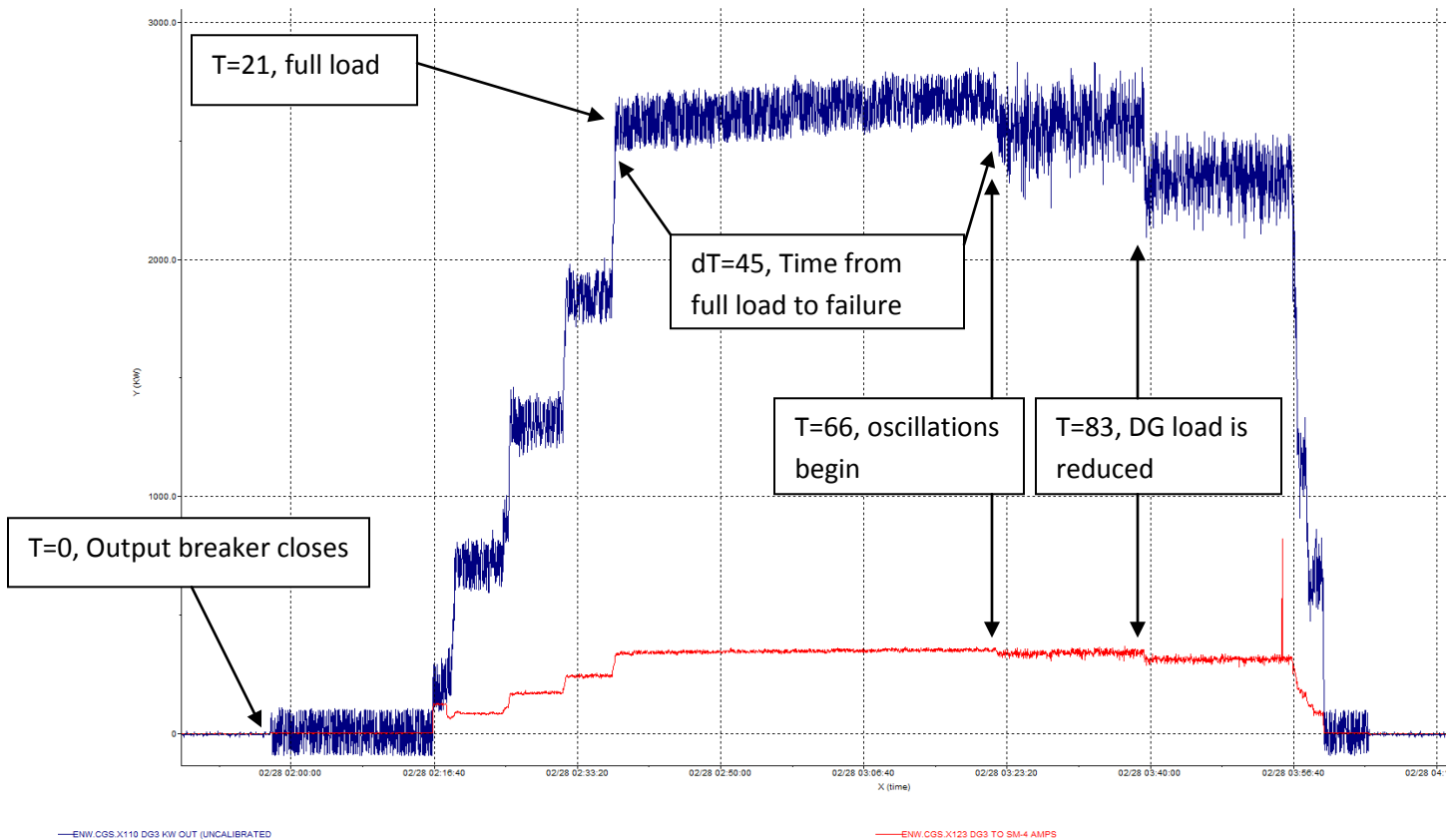

**NRC Response to Withdrawn FAQ:**

NEI 99-02, Revision 6, page F-26, lines 7-9, states, “*EDG failure to load/run*: Given that it has successfully started, a failure of the EDG output breaker to close, to successfully load sequence and to run/operate for one hour to perform its monitored functions.” NEI 99-02, Revision 6, page F-26, lines 13-15, states, “*EDG failure to run*: Given that it has successfully started and loaded and run for an hour, a failure of an EDG to run/operate.” The footnote on page 3 of Revision 6 of NEI 99-02 states, “Changes to data collection rules or practices required by the current revision of this document will not be applied retroactively to previously submitted data. Previously submitted data will not require correction or amendment provided it was collected and reported consistent with the NEI 99-02 revision and FAQ guidance in effect at the time of submittal.”

The “to successfully load sequence and to run/operate for one hour” wording in the EDG failure-to-load/run definition does not convey the intent that the EDG should not be considered running or operating during load sequencing. For example, the guidance does not use the word “then” to denote any intent that the EDG had to be “fully” loaded prior to being able to consider it running and operating. In addition, NEI 99-02 does not



**Final NRC Response**  
**FAQ 12-01 Columbia DG3 Failure (Withdrawn)**

state that the EDG has to be fully loaded in order to start the 1-hour period. The EDG had load on it right after the breaker closed; therefore, the NRC considers the EDG to have been “loaded” at this point.

In addition, NEI 99-02 does not define what it means for an EDG to be fully loaded, nor does it require that an EDG be “fully loaded.” It does not state whether fully loaded means that the EDG was operated at its design basis loading values, at its maximum load for the current application or test run, or operated at the vendor-specified continuous load rating. Given the ambiguity associated with what it means for an EDG to be “fully loaded,” NRC staff does not consider “fully loaded” to be a condition in which to start the 1-hour time clock.

The NRC staff evaluated this issue based on the characteristics of the EDG failure (i.e., the functional response of the EDG and the failure mechanism), and applying reasonable decision-making using the guidance in effect at the time of the failure. The oscillations were caused by foreign material in the governor – a condition that had existed for several years and that did not impact prior breaker closure and sequencing operations. Figure 1 in this FAQ shows that the oscillations did not occur during the breaker closure or the load sequencing or gradual loading action. Rather, the oscillations occurred 66 minutes after breaker closure and 45 minutes after the full load (for purposes of the test run) was achieved, which is indicative of a challenge to the EDG’s ability to continue to run for its mission time. Even though the foreign material existed in the governor for several years, the EDG had started and load sequenced several times without failure. Therefore, this failure appears to have been exacerbated by the running (vice start or loading) of the EDG.

Because Figure 1 data is more reflective of an EDG failure-to-run for its mission time rather than a loading failure, the EDG failure at Columbia should have been reported as a failure-to-run.

**Final NRC Response  
FAQ 12-02  
Counting of Compensatory Hours for Perimeter Intrusion Detection System**

**Plant:** Generic

**Date of Event:** January 2011

**Submittal Date:** July 13, 2011

**Licensee Contact:** Ron Gaston, (630) 657-3359, ronald.gaston@exeloncorp.com

**NRC Contact:** Brian Yip (301) 415-7638, Brian.Yip@nrc.gov

**Performance Indicator:** Protected Area Security Equipment Performance Index

**Site-Specific FAQ (App. D)?** No

**FAQ requested to become effective:** Upon Approval

### **Question Section**

#### **NEI 99-02 Guidance Needing Interpretation:**

The purpose and scope of the Physical Protection Cornerstone, as well as the associated Protected Area Security Equipment Performance Index Performance Indicator (PI), discussed in Section 2.7 of NEI 99-02, Revision 6.

#### **Event or circumstances requiring guidance interpretation:**

Effective March 31, 2010, a change to 10 CFR Part 73 required that intrusion detection equipment be capable of detecting both attempted and actual penetration of the protected area (PA) perimeter barrier before completed penetration of the PA perimeter barrier. The requirement for detection prior to penetration was a new requirement under the new security regulation that impacted sites that have their perimeter intrusion detection system (PIDS) installed inside the PA barrier.

Following the revision to 10 CFR Part 73, the NRC determined that the Early Warning System (EWS) used to satisfy PIDS for a licensee did not meet criteria outlined in the regulation. Compensatory measures were immediately implemented by the licensee to comply with the revised section 73.55 requirements until modifications to the system could be implemented.

The NRC questioned whether the hours currently being compensated to address the non-compliance should be counted against the Protected Area Security Equipment Performance Index (PI). The licensee believed that the purpose of the PIDS indicator was to monitor the effectiveness of maintenance for installed systems and that the resulting compensatory hours should not be counted.

The NRC subsequently determined that the purpose for the performance indicator should be revised to clearly state the intent to measure the unavailability of security equipment to perform its intended function.

**Final NRC Response  
FAQ 12-02  
Counting of Compensatory Hours for Perimeter Intrusion Detection System**

If licensee and NRC resident/region do not agree on the facts and circumstances, explain:

N/A

Potentially relevant existing FAQ numbers:

None

**Response Section**

Proposed Resolution of FAQ:

Revise NEI 99-02, Revision 6, and page 71 to read as indicated below:

21 This indicator serves as a measure of **unavailability of security** equipment to perform its intended  
22 function. When compensatory measures are employed because a segment  
23 of equipment is unavailable – not adequately performing its intended function, there is no  
24 security vulnerability but there is indication that something needs to be fixed. The PI **also**  
25 provides trend indications for evaluation of the effectiveness of the maintenance process  
26 and provides a method of monitoring equipment degradation as a result of aging that might  
27 adversely impact reliability. Maintenance consideration for protected area and vital area portals  
28 are appropriately and sufficiently covered by the inspection program.

Revise NEI 99-02, Revision 6, page 73 to read as indicated below:

18 Compensatory measures: Measures used to meet physical security requirements **when** the  
19 **required** equipment **is unavailable**. Protected Area protection is not diminished by the use of  
20 compensatory measures for equipment unavailability.

**Revise NEI 99-02, Revision 6, page 75 to read as indicated below:**

16 Degradation: Required system, equipment, **or** component is no longer available **or** capable of  
17 performing its **Intended Function**.

36 Intended **Function**: The ability of a component to detect the presence of an individual or display  
37 an image as intended by the manufacturer's equipment design capability **and as described in** the  
38 **Physical Security Plan**.

**NRC Response:**

NRC staff approves of the proposed revision of NEI 99-02. This change will be effective October 1, 2012 and shall be applied to 4Q2012 data that will be reported to the NRC in January 2013.

**Final NRC Response**  
**FAQ 12-03- St. Lucie Unplanned Scram with Complications**  
**For August 29, 2012 ROP WG Meeting**

**Plant:** St. Lucie Unit 1

**Date of Event:** March 31, 2012

**Submittal Date:** April 30, 2012

**Licensee Contact:** Eric Katzman

Tel/email: 772-467-7734, eric.katzman@fpl.com

**NRC Contact:** Tim Hoeg

Tel/email: 772-467-7017 tim.hoeg@nrc.gov

**Performance Indicator:** IE04, Unplanned Scrams with Complications (USwC)

**Site-Specific FAQ (Appendix D)?** YES

**FAQ requested to become effective when approved.** This FAQ concerns the St. Lucie Unit 1 March 31, 2012 manual reactor trip that was conservatively reported as an USwC. St. Lucie will revise the 1Q/2012 USwC occurrence data when this FAQ is approved.

## **Question Section**

**NEI 99-02 Guidance needing interpretation (include page and line citation):**

- NEI 99-02, Rev 6, Page 21 Lines 2-13.
- NEI 99-02, Rev 6, Appendix H, Page H-5, Lines 36-46 and Page H-6, Lines 1-12

**Event or circumstances requiring guidance interpretation:**

On November 27, 2011, St. Lucie Unit 1 was shutdown and commenced a refueling and extended power uprate outage. As a result of the extended shutdown period and very low decay heat, the reactor coolant pump (RCP) was the main driver for heating up the reactor coolant system (RCS) to achieve and maintain normal operating pressure and temperature (NOP/NOT) conditions during the March 31, 2012 reactor startup.

During reactor start-up on March 31, 2012, at approximately 0020 hours, the unit was in Mode 1 and holding at 10% power to complete testing of the steam bypass control system (SBCS), when pressure control valve (PCV) 8802, one of the steam dump to condenser valves, opened unexpectedly. Operators attempted to manually close PCV-8802, but were unsuccessful. At 0022 hours, Operators inserted a manual scram of the reactor and entered emergency operating procedure (EOP) EOP-01, Standard Post Trip Actions, as a result of the manual reactor trip and to address the cooldown caused by PCV 8802 being open. A brief period after the manual scram, it was reported that PCV-8802 went closed after the trip, which terminated the excessive steam demand.

While in EOP-1, at 0030 hours, Operators closed the main steam isolation valves (MSIVs) as directed by contingency step 4.6.D.2.3.1 due to steam generator pressure being less than 750 psia, terminating the cooldown. At 0037 hours, Operations confirmed that the EOP-01 exit

**Final NRC Response**  
**FAQ 12-03- St. Lucie Unplanned Scram with Complications**  
**For August 29, 2012 ROP WG Meeting**

condition criteria were satisfied in accordance with section 3.1 and the EOP-01 Diagnostic Flow Chart and entered EOP-02, "Reactor Trip Recovery."

While in EOP-02, at 0044 hours, Operators noted that RCS  $T_{AVG}$  had increased to 506 °F (from a low of 504 °F) and was slowly rising, concurrently the procedure directed that the uncomplicated Reactor Trip Safety Function Status Check for RCS Heat Removal was not met because RCS temperature was below 525°F. As previously noted, during the reactor startup with very low decay heat in the new reactor core, the temperature increase was slow due to reliance on RCP heat. While in EOP-2, at 0049 hours, the operators secured steam generator blowdown to increase the rate of RCS heat up.

At 0058 hours, Operations completed the EOP-02 directed re-diagnoses of the event by re-performing the EOP-01 diagnostic flow chart. The Shift Manager then determined that EOP-05, "Excess Steam Demand," was the appropriate EOP as a result of not meeting the Reactor Trip Safety Function Status Check for RCS Heat Removal (RCS  $T_{AVG}$  was not between 525 and 535°F). Upon entering EOP-05 it was known that no actions were necessary and none would be taken.

At 0330 hours, EOP-05 was exited as RCP heat addition restored RCS temperature to greater than 525°F. No EOP-05 actions were performed by Operations other than diagnostic checks to confirm that the excess steam demand was terminated.

Although the Combustion Engineering EOP network directs the exit of EOP-02 if any safety function status checks are not satisfied, in this particular event no steps were taken outside of the EOP-01 and EOP-02 contingency actions to mitigate the event. Because no excess steam demand was in progress, FPL concludes that this event does not meet the definition of an Unplanned Scram with Complications, which is "that subset of unplanned automatic and manual scrams that require additional operator actions beyond that of the "normal" scram," since the plant responded as expected considering reactor coolant temperature was being restored solely by the heat addition from the RCPs.

**If licensee and NRC resident/region do not agree on the facts and circumstances explain:**

The St. Lucie Resident Inspectors are in agreement with the facts presented above. However, the Resident Inspectors believe NEI guidance wording requires that the scram be counted as an unplanned scram with complications because another EOP was entered.

The Senior Resident further stated that since EOP-05 was not executed and no actions were taken, it is reasonable to consider that this reactor trip is uncomplicated.

**Potentially relevant existing FAQ numbers:**

**Final NRC Response**  
**FAQ 12-03- St. Lucie Unplanned Scram with Complications**  
**For August 29, 2012 ROP WG Meeting**

FAQ 481, proposed response page H-20, lines 18-46 and page H-21, lines 1-7, discussion includes the following:

“In the case of a routine scram the procedure entered will be exited fairly rapidly after verifying that the reactor is shutdown, excessive cooling is not in progress, electric power is available and reactor coolant pressures and temperatures are at expected values and controlled.”

As discussed above, the excess steam demand transient was terminated once EOP-01 directed closure of the MSIVs, and the reactor coolant temperature response was being restored as expected considering the power history of the core and temperature addition via the RCPs.

**Response Section:**

Proposed Resolution of FAQ:

This FAQ is proposed as a plant specific exemption [NEI 99-02, Rev. 6, page E-1, lines 18-19] from the guidance of NEI 99-02 because of the unique circumstances that lead to the condition. As previously described, St Lucie Unit 1 was in start up from an extended refuel outage in which a substantial amount of reactor fuel was replaced with new fuel. The result was very low decay heat available at the time of the reactor scram, which resulted in a slower temperature response.

As detailed above, the scram response procedure (EOP-01) was exited to the Reactor Trip Recovery procedure (EOP-02). Due to the RCS heat removal temperature band criteria not being met, the Operators entered another EOP during post trip recovery solely because of direction from another EOP, but no actions were required as a result of that EOP. EOP-02, Step 4.7.1, contingency action, directs restoration RCS temperature to within the band of 525 °F and 535 °F. This contingency action was fully met with no other actions required because the RCS temperature was being restored via RCP heat.

EOP-02, Step 4.1 is a continuous action step that has the operators re-verify the “uncomplicated Reactor Trip Safety Function Status Check” acceptance criteria every 15 minutes with the contingency action by re-diagnosing the trip in accordance with the EOP-01 Diagnostic Flow Chart. The RCS Heat Removal control contingency action in EOP-02 is “CONTROL SBCS or ADVs to restore RCS  $T_{AVG}$  to between 525 and 535°F” which is different than the EOP-01 contingency action to “ENSURE SBCS or ADVs are restoring RCS  $T_{AVG}$  to between 525 and 535°F.” The lowest RCS temperature noted was 504°F and it was rising due to RCP heat to restore RCS  $T_{AVG}$  to the required band.

Operators were aware that no excess steam demand was in progress because closure of the ADVs and MSIVs in EOP-01 terminated the cooldown. However, as a result of inconsistencies in

**Final NRC Response**  
**FAQ 12-03- St. Lucie Unplanned Scram with Complications**  
**For August 29, 2012 ROP WG Meeting**

RCS heat removal operator actions with EOP-01 and EOP-02, EOP-05 was required to be entered, but no actions were required.

FPL concludes that although the re-diagnosis of the event directed the operators to enter the most appropriate operational response procedure, the excess steam demand EOP was not “required” in that the EOP did not direct the operators to mitigate or stabilize the transient via the manipulation of any SSCs while within EOP-05.

This is consistent with NEI 99-02, page 21, lines 6-8:

“This step is used to determine if the scram was uncomplicated by counting if additional procedures beyond the normal scram response required entry after the scram.” [Emphasis added]

Additionally, NEI 99-02, Appendix H, page H-6, lines 1-3, also addresses the concept of “required” with respect to transition to another EOP during scram response procedures:

“The criteria in this question are used to verify there were no other conditions that developed during the stabilization of the plant in the scram response that required re-entry into the EOPs or transition to a follow on EOP.” [Emphasis added]

Based on the above, the St. Lucie Unit 1 manual trip of March 31, 2012 should not be counted as an unplanned scram with complications because of the following unique conditions (very low decay heat):

- Extended refuel outage from Nov 2011 thru March 2012
- Replacement of approximately 50 % of the reactor core and
- The only reactor coolant system heat addition was via the reactor coolant pumps

Operators entered EOP-05 as a result of not being able to meet the RCS heat removal safety function. FPL has entered this event into the corrective action program and is working with Westinghouse to clarify the EOP-02 RCS Heat Removal Safety Function to address RCS temperature based upon the time in core life.

As provided by NEI 99-02, Appendix D and Appendix E, this FAQ is requesting an exception to the guidance as written because of the unique circumstances that lead to the entry into an additional EOP. As previously stated, while the EOP was entered, no actions were directed.

**Final NRC Response**  
**FAQ 12-03- St. Lucie Unplanned Scram with Complications**  
**For August 29, 2012 ROP WG Meeting**

**NRC Response:**

In this FAQ, the licensee concluded that the scram does not meet the definition of an Unplanned Scram with Complications (USwC). In addition, the licensee identified guidance in NEI 99-02 that warrants interpretation. However, the licensee also indicated that it conservatively counted this as an USwC in its most recent PI data submittal and requested a plant-specific exemption from the NEI 99-02 guidance because of the unique circumstances that contributed to the entry into an additional EOP. Since the FAQ appears to argue two positions (one, that the scram does not meet the definition of an USwC, and two, that it meets the definition but should be exempted from the guidance) the staff will address both the guidance interpretation and the request for exemption.

**Purpose of the USwC Performance Indicator (PI):**

The purpose of the USwC PI is to monitor that subset of unplanned automatic and manual scrams that either require additional operator actions beyond that of the normal scram. Such events or conditions have the potential to present additional challenges to plant operators and, therefore, may be more risk-significant than uncomplicated scrams. The USwC performance indicator monitors the following conditions that have the potential to complicate the operator's scram recovery action:

- Reactivity Control
- Turbine Trip
- Power available to Emergency Busses
- Need to actuate emergency injection sources
- Availability of Main Feedwater
- Utilization of scram recovery Emergency Operating Procedures (EOPs)

**Definition of the USwC PI:**

The USwC indicator is defined, in part, as the number of unplanned scrams while critical, both manual and automatic, during the previous 4 quarters that require additional operator actions as defined by the applicable flowchart (NEI 99-02, page 25, Figure 2). The PWR flowchart focuses on six conditions that distinguish the difference between a complicated and uncomplicated scram. The use of the flowchart minimizes subjective determination so reliable PIs are generated.

**Position 1: Request for Interpretation of NEI Guidance:**

Excerpt 1: NEI 99-02, Revision 6, page 21, lines 2-13, refers to one of the conditions to consider when determining a scram as an USwC as follows:

*Was the scram response procedure unable to be completed without entering another EOP?*



**Final NRC Response**  
**FAQ 12-03- St. Lucie Unplanned Scram with Complications**  
**For August 29, 2012 ROP WG Meeting**

*The response to the scram must be completed without transitioning to an additional EOP after entering the scram response procedure (e.g., ES01 for Westinghouse). This step is used to determine if the scram was uncomplicated by counting if additional procedures beyond the normal scram response required entry after the scram. A plant exiting the normal scram response procedure without using another EOP would answer this step as “No”. The discretionary use of the lowest level Function Restoration Guideline (Yellow 11 Path) by the operations staff is an approved exception to this requirement. Use of the Re-diagnosis Procedure by Operations is acceptable unless a transition to another EOP is required.*

The operators transitioned from 1-EOP-02, Reactor Trip Recovery, to 1-EOP-05, Excess Steam Demand (ESD), after re-diagnosis (Safety Functions Status Check) of the scram event. The transition occurred because the entry conditions into 1-EOP-02 were not satisfied because  $T_{avg}$  was below the allowable band of 525-535°F. Failure of the steam dump valve, which caused the excessive steam demand, along with low decay heat levels contributed to the low  $T_{avg}$ . The contingency action in 1-EOP-02 directed the operators to enter either the Appropriate Optimal Recovery Procedure or 1-EOP-15, Functional Recovery. The operators decided to transition to an Appropriate Optimal Recovery Procedure and entered 1-EOP-05 because an excessive steam demand event occurred. No manipulations of controls were taken by operators while in 1-EOP-05. This procedure established an expected response for  $T_{avg}$  to be stable or decreasing. In this case, however, the objective was to increase  $T_{avg}$  to the 1-EOP-02 allowable band.  $T_{avg}$  increased due to heat generation from reactor coolant pump operation. Once  $T_{avg}$  reached the 525-535°F temperature band, 1-EOP-05 was exited. In its FAQ submittal, the licensee asserted that the definition of an USwC was not met because no excessive steam demand was in progress. However, the guidance does not list excessive steam demand as a flowchart question. Nor does the guidance define operator actions as manipulations of controls; in fact, none of the flowchart questions ask if operators were required to manipulate controls. The flowchart questions focus on hardware performance, plant response, and operating procedure impacts. The question germane to this FAQ is “Was the scram response procedure unable to be completed without entering another EOP?” The guidance essentially defines “additional operator actions beyond that of a normal scram” as the action of transitioning to another EOP. Because St. Lucie operators transitioned to an additional EOP to support scram recovery, the answer to this question is “yes,” and the scram clearly meets this criterion for USwC.

Excerpt 2: NEI 99-02, Appendix H, page H-5, Section H 1.6 provides additional guidance on the conditions to consider a scram complicated as follows:

***H 1.6 Was the scram response procedure unable to be completed without entering another EOP?***

*When a scram occurs plant operators enter the EOPs to respond to the condition. In the case of a routine scram the procedure entered will be exited fairly rapidly after verifying that the reactor is shutdown, excessive cooling is not in progress, electric power is available, and reactor coolant pressures and temperatures are at expected*

**Final NRC Response**  
**FAQ 12-03- St. Lucie Unplanned Scram with Complications**  
**For August 29, 2012 ROP WG Meeting**

*values and controlled. Once these verifications are done and the plant conditions are considered “stable” operators may exit the initial procedure to another procedure that will stabilize and prepare the remainder of the plant for transition to the normal operating procedures. The plant could then be maintained in Hot Standby, to perform a controlled normal cool down, or to begin the restart process. The criteria in this question is used to verify there were no other conditions that developed during the stabilization of the plant in the scram response that required re-entry into the EOPs or transition to a follow on EOP.*

*There are some EOPs that are used specifically at the operator discretion and are not required to be used. In the Westinghouse EOP suite these are Yellow Path functional restoration procedures and the re-diagnosis procedures. These procedures typically verify that the operator is taking the correct action (re-diagnosis) or the stabilization of some minor plant parameters (Yellow path). Use of these procedures is an allowed exception to this step. The transition out of these procedures to an EOP different from the current procedure in effect, i.e. a new procedure or the base procedure, would count as a complication.*

Normal scram response is defined in FAQ 10-02 as follows:

*Scram Response refers to the period of time that starts with the scram and concludes when operators have completed the scram response procedures and the plant has achieved a stabilized condition in accordance with approved plant procedures and as demonstrated by meeting the following criteria. For a PWR:*

- Pressurizer pressure is within the normal operating pressure band.*
- Pressurizer level is within the no-load pressurizer band.*
- Level and pressure of all steam generators are within the normal operating bands.*
- RCS temperature is within the allowable RCS no-load temperature band ( $T_{ave}$  if any RCS pump running,  $T_{cold}$  if no RCS pumps running).*

Normal scram response includes stabilization of plant conditions. RCS coolant temperature was not in the required band for 1-EOP-02 during plant stabilization. Operators noted that RCS temperature was at 506 °F, which is below the required 525-535°F band. Temperature returned to the 1-EOP-02 required band approximately 3 hours after the scram; therefore the scram response was not exited fairly rapidly.

The USwC PI provides information regarding licensee performance in the Initiating Events Cornerstone. The key attributes measured by this PI, as described in IMC 0308, Attachment 1, are human error, procedure quality, design, and equipment performance. The equipment performance attribute is relevant because the failure of the steam dump valve both initiated the event and caused the excessive RCS cooldown. The staff notes that the valve remained failed

**Final NRC Response**  
**FAQ 12-03- St. Lucie Unplanned Scram with Complications**  
**For August 29, 2012 ROP WG Meeting**

open for some brief period of time even after the scram. An ESD event primarily affects the reactivity control and RCS heat removal safety functions. In addition, the valve failure created the potential for a Safety Injection (SI) actuation had the operators not manually scrambled the reactor and shut the MSIVs immediately. Although operators may not have been significantly challenged by plant conditions and appear to have adequately responded to the event, the conditions did require additional actions (closure of MSIVs. The excessive cooldown caused by the steam dump valve failure also created the potential to present additional challenges to the plant operations staff and, therefore, may have been more risk-significant than an uncomplicated scram.

The operators transitioned to 1-EOP-05 because an ESD event had occurred. The NEI 99-02 guidance does not distinguish between levels of complication for the USwC; scrams involving minor and significant complications are treated equally under this PI. Although the operators managed the event very well, they were placed in a position where they had to choose to not follow the EOP structure (1-EOP-02). Since the EOP structure provides the operators with defense-in-depth during an event, this scram event highlights the potential need for minor EOP enhancements. The licensee has indicated that such enhancements are being made.

Conclusion regarding the Requested Interpretation of NEI Guidance:

The NRC's conclusion is that the March 31, 2012, scram was appropriately submitted as an USwC, consistent with governing guidance. The staff further believes that this USwC meets the intent of that guidance.

**Position 2: Request for Exemption from NEI 99-02:**

The FAQ process allows a licensee to request an exemption from the guidance for plant-specific circumstances, such as design features, procedures, or unique conditions. The licensee submitted this FAQ, in part, to request a plant-specific exemption from the NEI 99-02 guidance because of unique circumstances that contributed to the entry into an additional EOP (1-EOP-5, Excess Steam Demand).

NEI 99-02, Appendix D, page D-1, lines 16-21 provides additional information on plant-specific exemptions of the NEI 99-02 guidance as follows:

*The NEI 99-02 guidance was written to accommodate situations anticipated to arise at a typical nuclear power plant. However, uncommon plant designs or unique conditions may exist that have not been anticipated. In these cases, licensees should first apply the guidance as written to determine the impact on the indicators. Then, if the licensee believes that there are unique circumstances sufficient to warrant an exception to the guidance as written, the licensee should submit a Frequently Asked Question to NEI for consideration at a public meeting with the NRC.*

The NRC staff does not consider the conditions that contributed to the low decay heat level unique. In general, all plants have varying levels of decay heat that depend on operating history, shutdown time, and core loading. The staff also notes that shutdowns of the duration at St. Lucie

**Final NRC Response**  
**FAQ 12-03- St. Lucie Unplanned Scram with Complications**  
**For August 29, 2012 ROP WG Meeting**

are not uncommon. The impact of these shutdowns combined with core changes would be considered by engineering and operations staff prior to restart. This condition could exist at any plant and, therefore, is not unique to St. Lucie.

The NRC staff undertook a review of prior exemptions to confirm its application of the NEI guidance governing exemptions based on the precedent established. The staff found that a majority of the granted exemptions were either related to uncommon plant designs or unanticipated environmental conditions that impact the PIs.

Conclusion regarding the Exemption Request:

Because the St. Lucie circumstances are not unique, and based on the precedent established by prior exemptions, the NRC staff does not support the plant-specific exemption.