

Brookhaven National Laboratory	Number: PS-ESH-0088	Revision: 001
	Effective: 01/20/12	Page 1 of 12
Subject: Laser Safety Program Documentation – 902 Room L1		

**BROOKHAVEN NATIONAL LABORATORY
LASER CONTROLLED AREA
STANDARD OPERATING PROCEDURE (SOP)**

This document defines the safety management program for the laser system(s) listed below. All American National Standard Institute (ANSI) Hazard Class 3B and 4 laser systems must be documented, reviewed, and approved through use of this form. Each system must be reviewed *annually*. Modify the template for this document to fit your particular circumstance.

<i>System description:</i> Pico second pulsed laser
<i>Location:</i> Building 902, Room L1

LINE MANAGEMENT RESPONSIBILITIES

The Owner/Operator(s) for this laser is/are listed below. The Owner/Operator is the Line Manager of the system and must ensure that work with this laser conforms to the guidance outlined in this form.

Owner/Operator:		
<i>Name:</i> Weixing Cheng, Belkacem Bacha	<i>Signature:</i>	<i>Date:</i> Jan 20, 2012

AUTHORIZATION

Work with all ANSI Class 3B and 4 laser systems must be planned and documented with this form. Laser system operators must understand and conform to the guidelines contained in this document. This form must be completed, reviewed, and approved before laser operations begin. The following signatures are required. Additional signatures, e.g., the ALSO, are to be added to this signature block when necessary.

<i>BNL LSO (printed name)</i> C. Weilandics	<i>Signature</i> On file	<i>Date</i>
<i>Department ES&H Coordinator (printed name)</i> L. Stiegler	<i>Signature</i> On file	<i>Date</i>
<i>Department Chair/Division Manager (printed name)</i>	<i>Signature</i>	<i>Date</i>

APPLICABLE LASER OPERATIONS			
<input checked="" type="checkbox"/> Operation	<input type="checkbox"/> Maintenance	<input type="checkbox"/> Service	<input type="checkbox"/> Specific Operation (specify)

RELATIONSHIP TO OTHER DOCUMENTS

Specifically name other documents, (such as ESRs, SADs/SARs, other SOPs) that describe hazards present in the Laser Controlled Area outside the scope of this document.

LASER SYSTEM HAZARD ANALYSIS

Hazard analysis requires information about the laser system characteristics and the configuration of the beam distribution system. The analysis includes both laser (light) and non-laser hazards. A Nominal Hazard Zone (NHZ) analysis must be completed to aid in the identification of appropriate controls. Laser system characteristics necessary for eyewear calculations and NHZ analysis are described along with the results in the PPE section of this document.

LASER SYSTEM CHARACTERISTICS						
Laser Type <i>(Argon, CO₂, etc.)</i>	Wavelength(s) (nm)	ANSI Class	Maximum Power or Energy/Pulse (W or J)	Pulse Length (s)	Repe- tition Rate (Hz)	Beam Diameter (mm)
PicoQuant LDH-P-C-405 Diode laser	405 nm	3B	1mW avg. pwr.	<70ps FWHM	Up to 40MHz	elliptical 1.5mm*3.5 mm

Applicable Laser Operations:

Describe the scope of the work to be done, and how the laser system is used. Provide information regarding unusual circumstances necessary for evaluation of hazards by the LSO not provided elsewhere in this document (e.g., laser beams entering other equipment such as vacuum chambers and microscopes or propagated into unexpected places/directions).

The ps-pulsed laser (PicoQuant LDH-P-C-405 laser head, with PDL 800-B driver) will be used in the optics lab located in room L1 of Building 902. The major tasks are testing fast cameras which we have in the optics lab prior to the NSLS2 storage ring starting up with synchrotron light. The two cameras we are going to test are Hamamatsu C5680 streak camera and Princeton Instrument PiMax3 gated camera.

The pulsed laser will be set up on the optical table, radiated blue light will be guided via optical fiber onto the camera slit/cathodes. The laser is typically operating at low intensity mode. Neutral density filters will be added to limit the photons into cameras. The optical table height is 810mm.

Laser System Configuration:

Describe the laser beam path for fixed components of the system, and provide a functional/block diagram for complicated beam paths. Photographs may be used where they convey sufficient information. Note that Engineering Controls are described in a separate section below.

Identify hazards mitigated or created by the placement, movement, and/or status of components. Examples include any protective housings, beam stops, beam enclosures, and any critical optics (mirrors or lenses that could misdirect the beam and result in personnel hazard).

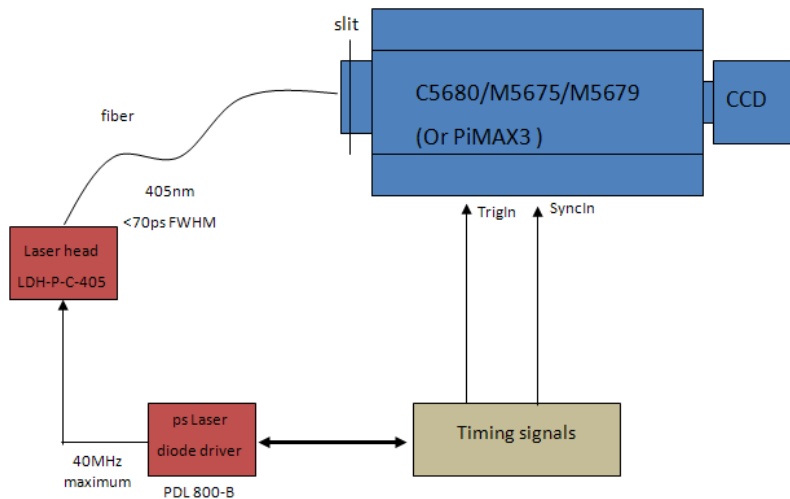

Showing in the diagram above, the ps laser will generate <70ps FWHM photon pulses. The ps pulse signal is guided to the camera slit/cathode. Alternatively, mirrors and lens may be used to guide the light onto cameras. At less ND=1 neutral density filter will be inserted in the beam pass, hence the maximum power will not exceed 0.1mW.

For specific laser-related hazards below, provide details (types, quantities, use) as appropriate. Details of non-laser related hazards should be cross-referenced to the other documents cited above.:

Cryogen Use

e.g., laser cooling

Chemicals & Compressed Gases

e.g., laser dyes, solvents, excimer laser gases

Electrical Hazards

Describe circumstances that could lead to exposure to electrical hazards.

Other Special Equipment

Equipment used with the laser[s] that may introduce additional hazards, e.g., beam viewers.

DESCRIBE CONTROLS

Recognition, evaluation, and control of laser hazards are governed by the following documents:

American National Standards Institute (ANSI) Standard for Safe Use of Lasers (ANSI Z136.1-2007)

BNL SBMS Subject Areas:

Laser Safety Subject Area
Interlock Safety Subject Area

ENGINEERING CONTROLS

- | | | |
|---|--|--------------------------------|
| <input checked="" type="checkbox"/> Beam Enclosures | <input type="checkbox"/> Protective Housing Interlocks | <input type="checkbox"/> Other |
| <input checked="" type="checkbox"/> Beam Stop or Attenuator | <input checked="" type="checkbox"/> Key Controls | |
| <input type="checkbox"/> Activation Warning System | <input type="checkbox"/> Other Interlocks | |
| <input type="checkbox"/> Ventilation | <input checked="" type="checkbox"/> Emission Delay | |

Describe each of the controls in the space provided below this text. Interlocks and alarm systems must have a design review and must be operationally tested every six months. Controls incorporated by the laser manufacturer may be referenced in the manuals for these devices. **If any of the controls utilized in this installation requires a design review by the LSO/ALSO and the LESO, a copy of the design review documentation and written testing protocol must be on file. Completed periodic interlock testing checklists should be retained to document the testing history.**

Engineering Controls Description:

1. Beam Enclosures: Normally the beam will be coupled to the camera(s) through an optical fiber; this will be a Class 1 (totally enclosed) operation
2. Beam Stop or Attenuator: Neutral density filter and beam stop will be used
3. The optics room has authorized key access with proper training
4. Emission delay: there is a 10 second delay before the laser will turn on after the key switch is actuated.

ADMINISTRATIVE CONTROLS

Laser Controlled Area Signs Labels Operating Limits

Class 3B and 4 lasers are required to be operated in Laser Controlled areas with appropriate warning signs and labels. The format and wording of laser signs and labels are mandated by BNL and ANSI standards. Only the standard signs are acceptable. Standard signs are available from the BNL Laser Safety Officer. All lasers must have a standard label at least indicating the system's wavelength and power. Required labels must remain legible and attached. The manufacturer should label commercial systems.

Describe administrative operational limits (e.g., requirements to operate at reduced power) if appropriate.

Approved signs (by the LSO) will be used on the entry to the laser controlled area where the laser is being used.

Standard Operating Procedures (SOPs) are required for Class 3B and Class 4 laser system operation, maintenance/servicing and laser alignment. The SOPs need only contain the safety information necessary to perform these tasks and identify appropriate control measures including postings (showing required ODs for eyewear and ANSI hazard class) and any additional personal protective equipment required. The BNL Laser Safety Officer must approve SOPs and copies should be available at the laser installation for reference and field verification of stated control measures.

Operation:

Describe controls for routine use and adjustments of laser system(s).

See Appendix 1

Maintenance/Service:

Describe additional controls required to maintain laser operation. May or may not require beam access. Follow manufacturer instructions where appropriate. Routine maintenance: replacing consumables (flashlamps, gases, dyes, etc.). Non-routine service: Less frequent: Replacing damaged components, diagnostics, etc.

The laser head and power supply contain no user serviceable parts, therefore no maintenance/service is expected to be performed by BNL personnel.

Outside service personnel:

Indicate how outside service personnel are trained and supervised. Work performed by outside service personnel is planned according to the Work Planning and Control for Experiments and Operations Subject Area and regulated by the Guest and Visitors Subject Area.

It is anticipated that any problems encountered will require that the unit be shipped out for repairs.

Alignment:

As most laser accidents occur during alignment, provide a description of routine procedures where appropriate and controls to mitigate the hazards. For non-routine procedures, provide a

Number: PS-ESH-0088	Revision: 01	Effective: 01/20/2012	Page 6 of 12
----------------------------	---------------------	------------------------------	---------------------

safety envelope necessary to protect workers. This includes activities such as initial system/experimental alignment.

Alignment SOP:

1. There shall be no intentional intrabeam viewing with the eye!!
2. Maintain good housekeeping practices on laser tables; keep the area where you will be working clear of excess objects that might scatter a beam unpredictably, and keep combustible materials away from class 4 hazards or focused 3B lasers.
3. Consider the use of low power class 1-3A/3R coaxial CW alignment lasers when convenient.
4. During alignment procedures, only persons immediately involved in the procedure are to be in the LCA.
5. When it is possible that hazardous beams are not completely contained on the laser tables, the room must be posted with a temporary alignment warning sign on the door warning those that may enter not to until the procedures are completed and the sign removed.
6. During all times when the possibility for inadvertent exposure to laser light exists, appropriate laser safety eyewear must be worn. The appropriate ratings are listed in the PPE section, and discussed further below.
7. Definite termination of the beam path must be in place before the beam is allowed to propagate. Use moveable beam stops to ensure that uncontrolled propagation does not occur.
8. Alignment procedures are always to be performed with the minimum practical laser power levels and repetition rates.
9. If performing maintenance or realignment, use remote viewing using the CCD camera whenever possible. If visual inspection is absolutely necessary, attenuate all beams to barely visible levels using neutral density filters.
10. Following a new laser beam set-up or change in alignment, a survey of the beam path will be conducted to verify that all unwanted beams and reflections have been properly terminated. Opaque barriers will be used to confine low intensity stray reflections and scattered light to the optical tables.
11. Routine laser-specific alignment procedures may be simple or complex. In either case, specific procedures are outlined in the operation and alignment manuals supplied by the manufacturers, and they must be followed.
12. Pre-position optical components during gross alignment as best as possible and secure them before allowing beams to propagate.
13. Be aware of the potential for errant reflections (stray beams) from and leaked beams transmitted through components such as polarizers and dielectric mirrors. For example, do not use or rotate calcite polarizers with escape windows without first being sure that all exit beams will be blocked. Check for stray beams at each step and again after completing all alignment steps.

Laser system configuration changes:

Number: PS-ESH-0088	Revision: 01	Effective: 01/20/2012	Page 7 of 12
----------------------------	---------------------	------------------------------	---------------------

Changes to the laser system can result in new concerns about safety or damage to equipment. Describe how changes are communicated between coworkers (e.g., lab notebooks, logs, whiteboards).

PERSONAL PROTECTIVE EQUIPMENT

Skin Protection: If the potential exists for damaging skin exposure as determined by the LSO (particularly for UV lasers 295-400 nm or welding/cutting applications), describe the hazard(s) and the method(s) used for mitigation. Skin-covers and/or sunscreen creams are recommended.

Eyewear: All laser protective eyewear must be clearly labeled with the optical density and wavelength for which protection is afforded. Eyewear should be stored in a designated sanitary location. Eyewear must be routinely checked for cleanliness and lens surface damage.

1. For invisible beams, eye protection against the full beam must be worn at all times unless the beam is fully enclosed.
2. For visible beams, eye protection against the full beam must be worn at all times during gross beam alignment.
3. Where hazardous diffuse reflections are possible, eye protection with an adequate Optical Density for diffuse reflections must be worn within the nominal hazard zone at all times.
4. If you need to operate the laser without wearing eye protection against all wavelengths present, explain the circumstances and the precautions that will be taken to prevent eye injury.

Define eyewear optical density requirements by calculation or manufacturer reference and list other factors considered for eyewear selection. The BNL Laser Safety Officer will assist with any required calculations.

Most accidents occur during alignment. Extra care must be taken during alignment. Eyewear must be worn during alignment, but it must be remembered that eyewear is NOT the first level of laser safety. Eyewear protects the wearer only when all other safety procedures and equipment have failed. Better protection is provided by careful consideration of procedures and proper beam management.

LASER SYSTEM CHARACTERISTICS						
Laser Type (Argon, CO ₂ , etc.)	Wavelength(s) (nm)	ANSI Class	Maximum Power or Energy/Pulse (J or W)	Pulse Length (s)	Repe- tition Rate (Hz)	Beam Diameter (mm)
Diode laser	405 nm	3B	1mW	<70ps FWHM	Up to 40MHz	elliptical 1.5mm*3.5 mm

EYEWEAR REQUIREMENTS					
Laser System Hazard	Wavelength (nm)	Calculated Intra-beam Optical Density	Diffuse Optical Density*	NHZ** (meters)	Appropriate Eye Wear***
Diode laser	403	1 [†]	NA	<0.2	

EYEWEAR SPECIFICATIONS		
Laser System Eyewear Identification***	Wavelengths	Optical Density
LaserShields BDA	190-375nm 405nm	5+ 2+

*Diffuse ODs are calculated assuming a 600 second exposure, a viewing distance of 20 cm, perfect reflectivity, and viewing normal to the surface. The ODs required can decrease for more typical conditions in the laboratory.

**The Nominal Hazard Zone is that zone or distance inside which exists a hazard to the eye from a diffuse reflection (as well as direct or specularly reflected light) for the time specified, in this case, 600 seconds (10 minutes).

Number: PS-ESH-0088	Revision: 01	Effective: 01/20/2012	Page 9 of 12
----------------------------	---------------------	------------------------------	---------------------

***Specified eyewear may not be the only possible option, but represents an approved choice; depending on other laser hazards present in the lab, other eyewear may be acceptable provided the optical densities are equivalent or greater than those required.

† Calculation based on 40MHz operation, 10 second exposure due to minimal visual stimulus.

TRAINING

LASER SAFETY TRAINING

Laser Operators must complete sufficient training to ensure that they can identify and control the risks presented by the laser systems they use. Owners/Operators must receive a baseline medical surveillance eye examination, documented in the Occupational Medicine Clinic before using lasers. Owners/Operators and Qualified Laser Operators must complete the awareness level BNL online training course (TQ-LASER) every two years.

Qualified Laser Operators must also complete system-specific orientation with the system owner/operator. **System-specific training shall be done using the checklist in Appendix 2.**

All Laser Training shall be documented on the On-The-Job Training form found here:

<http://www.nsls.bnl.gov/training/Courses/Lasers/>

All laser safety training must be repeated every two years.

Appendix 1

LDH-P-C-405B picosecond pulsed laser operation checklist (For streak camera and gated camera experiments)

- Post Laser Class 3B sign on L1 door
- Close the L1 door before turning on laser
- Wear proper laser safety goggle (see SOP)
- Align laser by looking at beam scatter from white paper

Appendix 2

LDH-P-C-405B picosecond Pulsed Laser Training Checklist

(For standard operation only—*not* setup or alignment)

- General laser safety and laser hazards
- Good practice in the lab
- Review of laser setup and beampath
- Description of laser output (wavelength, pulse energy, average power)
- Review of standard operating procedure
Normal operation and configuration, Nominal Hazard Zone
- Do not tamper with enclosure or laser
- Make sure laser Class 3B sign is posted on Lab door