

# Catch Tank 241-C-301 Retrieval Feasibility Study

Prepared by **J. J. Elsen, Columbia Energy and Environmental Services, Inc.** for  
**Washington River Protection Solutions, LLC**  
Richland, WA 99352  
U.S. Department of Energy Contract DE-AC27-08RV14800

EDT/ECN: 824046 UC:  
Cost Center: Charge Code:  
B&R Code: Total Pages:

Key Words: miscellaneous underground storage tank, MUST, 241-C-301, C-301, Catch Tank, retrieval.

Abstract: This document compiles information pertaining to catch tank 241-C-301. The report is intended to be a collection point of information to support potential retrieval and closure of catch tank 241-C-301.

---

TRADEMARK DISCLAIMER. Reference herein to any specific commercial product, process, or service by trade name, trademark, manufacturer, or otherwise, does not necessarily constitute or imply its endorsement, recommendation, or favoring by the United States Government or any agency thereof or its contractors or subcontractors.

  
Release Approval

9/22/2010  
Date

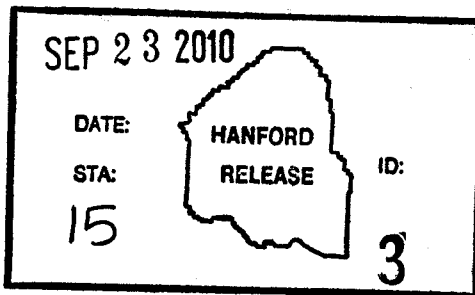

Release Stamp

**Approved For Public Release**

**TABLE OF CONTENTS**

1.0 INTRODUCTION .....1

2.0 PURPOSE AND SCOPE.....1

3.0 BACKGROUND .....1

    3.1 CATCH TANK 241-C-301.....1

    3.2 CATCH TANK 241-C-301 PROCESS HISTORY .....7

4.0 RETRIEVAL BACKGROUND .....9

    4.1 RETRIEVAL CRITERIA .....9

    4.2 PAST 301-SERIES CATCH TANK PUMPING .....10

    4.3 VACUUM RETRIEVAL.....11

    4.4 MODIFIED SLUICING .....15

    4.5 MISCELLANEOUS CATCH TANK PUMPING.....20

    4.6 OTHER CONSIDERATIONS.....20

        4.6.1 In-Tank Vehicle .....21

        4.6.2 Enhanced Articulating Sluicers.....21

        4.6.3 Eductor System .....21

        4.6.4 Low Residual Volume Pump .....22

        4.6.5 Waste Transfer Route .....22

        4.6.6 Double-Shell Tank Volume .....23

5.0 CLOSURE .....24

    5.1 TANK PREPARATION .....25

    5.2 GROUT FILL OPERATIONS .....25

    5.3 CLOSEOUT.....26

6.0 COST AND SCHEUDLE.....27

7.0 RECOMMENDATIONS .....27

8.0 REFERENCES .....29

**LIST OF APPENDICES**

A CATCH TANK 241-C-301 LIQUID LEVELS AND ACTIVITIES 1974 TO 1985  
(WHC-SD-WM-TI-356)..... A-i

B CATCH TANK 241-C-301 LIQUID SAMPLE DATA 1974 (RPP-RPT-42231)..... B-i

C CATCH TANK 241-C-301 LIQUID SAMPLE DATA 1985 (RPP-RPT-42231)..... C-i

D STABILIZATION EVALUATION FORM FOR CATCH TANK 241-C-301  
(RPP-RPT-42231)..... D-i

E	COST AND SCHEDULE ESTIMATES FOR DEPLOYMENT OF A SLUICING WASTE RETRIEVAL SYSTEM IN C-301.....	E-i
F	COST AND SCHEDULE ESTIMATES FOR DEPLOYMENT OF A VACUUM RETRIEVAL SYSTEM IN C-301 .....	F-i

**LIST OF FIGURES**

1.	Aerial Photograph with Catch Tank and Diversion Boxes.....	2
2.	Catch Tank and Diversion Boxes .....	3
3.	Catch Tank Configuration.....	4
4.	Catch Tank Riser Layout .....	5
5.	Catch Tank Risers 1 Through 4 .....	6
6.	Catch Tank Risers 5 Through 8 .....	7
7.	Vacuum Retrieval System Schematic.....	12
8.	Modified Sluicing Retrieval Schematic .....	16

**LIST OF TABLES**

1.	241-C-301 Riser Configuration .....	5
2.	241-C-301 Liquid Levels and Pumping.....	8
3.	241-C-301 Liquid Sample Data.....	8
4.	C-200 Vacuum Retrieval Summary.....	13
5.	Catch Tank 241-C-301 Vacuum Retrieval Estimate .....	14
6.	Retrieval Data Summary Tank 241-C-103 Modified Sluicing.....	16
7.	Catch Tank 241-C-301 Sluicing Retrieval Estimate.....	17
8.	Catch Tank 241-C-301 Residual Waste Volume Levels .....	18

## LIST OF TERMS

### Abbreviations and Acronyms

DST	double-shell tank
HFFACO	Hanford Federal Facility Agreement and Consent Order
HEPA	high-efficiency particulate air
HIHTL	hose-in-hose transfer line
IMUST	inactive miscellaneous underground storage tank
MARS	mobile arm retrieval system
MUST	miscellaneous underground storage tank
NESL	non entry systems limited
psi	pounds per square inch
SST	single-shell tank
VRS	vacuum retrieval system
WMA	waste management area



## 1.0 INTRODUCTION

This feasibility study was prepared in response to Hanford Federal Facility Agreement and Consent Order (HFFACO) Milestone M-45-80 which requires development of a retrieval alternatives feasibility report for the 241-C-301 catch tank. The objective of this task is to provide an evaluation of alternatives for removal of waste from the C-301 catch tank, and estimate the costs and benefits for each viable alternative.

## 2.0 PURPOSE AND SCOPE

This document compiles information pertaining to catch tank 241-C-301. The report is intended to be a collection point of information in support of waste retrieval and possible closure of catch tank 241-C-301. The information includes the catch tanks physical configuration, riser size and location, reported waste volume, historical liquid sample data, pumping information and discussion of waste retrieval alternatives.

## 3.0 BACKGROUND

### 3.1 CATCH TANK 241-C-301

Catch tank 241-C-301 is located in the northeast corner of the 241-C tank farm complex. The catch tank received drainage from the following four diversion boxes:

- 241-C-151
- 241-C-152
- 241-C-153
- 241-C-252.

These four diversion boxes were associated with waste transfers to the 241-C tank farm primarily from the B Plant and PUREX facilities and incidental wastes from Hot Semi-Works. A flow diagram for the catch tank and associated structures is depicted on H-2-44502, *Flow Diagram Waste Transfer and Storage Facilities*. Figure 1 shows the field layout of the catch tank and diversion boxes as taken from an aerial photograph of the 241-C tank farm. Figure 2 contains a schematic representation of the catch tank and diversion box arrangement. The catch tank and diversion boxes were constructed between 1943 and 1945 along with the majority of the 241-C tank farm complex.

Figure 1. Aerial Photograph with Catch Tank and Diversion Boxes.

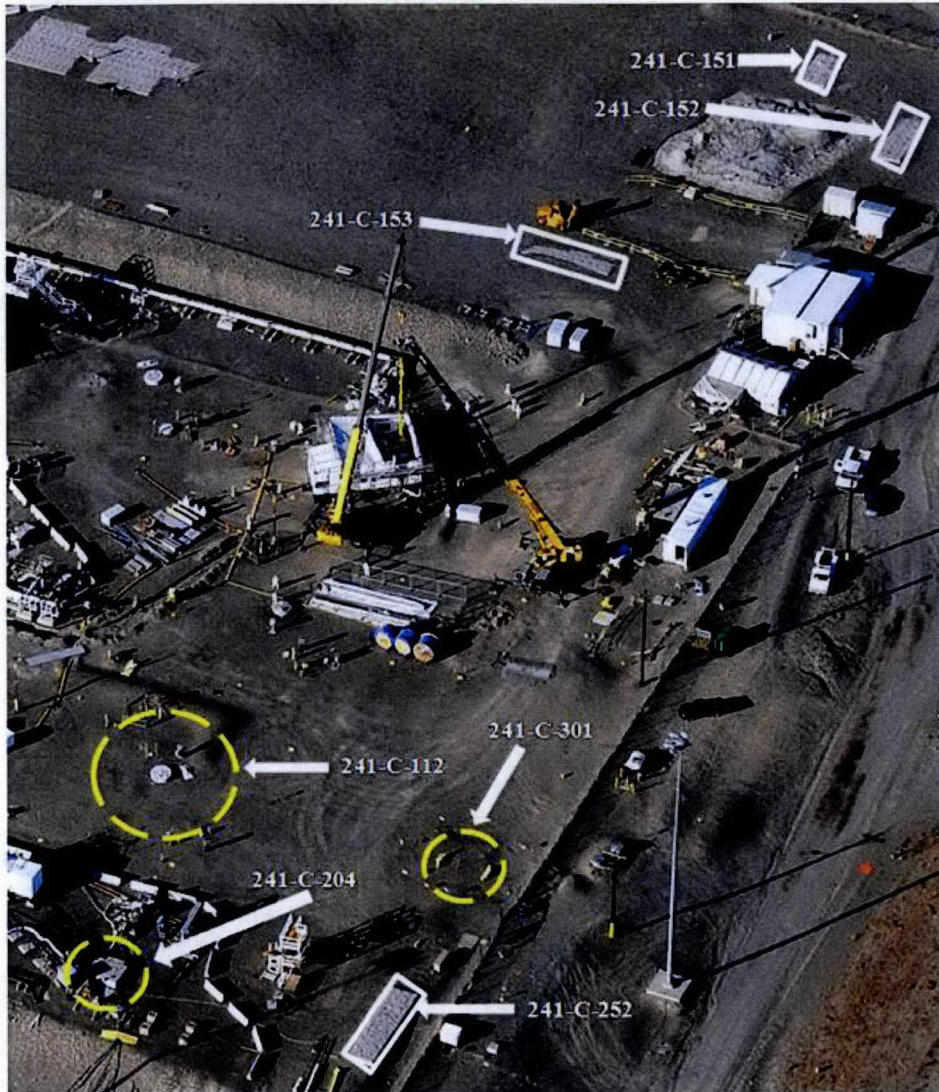

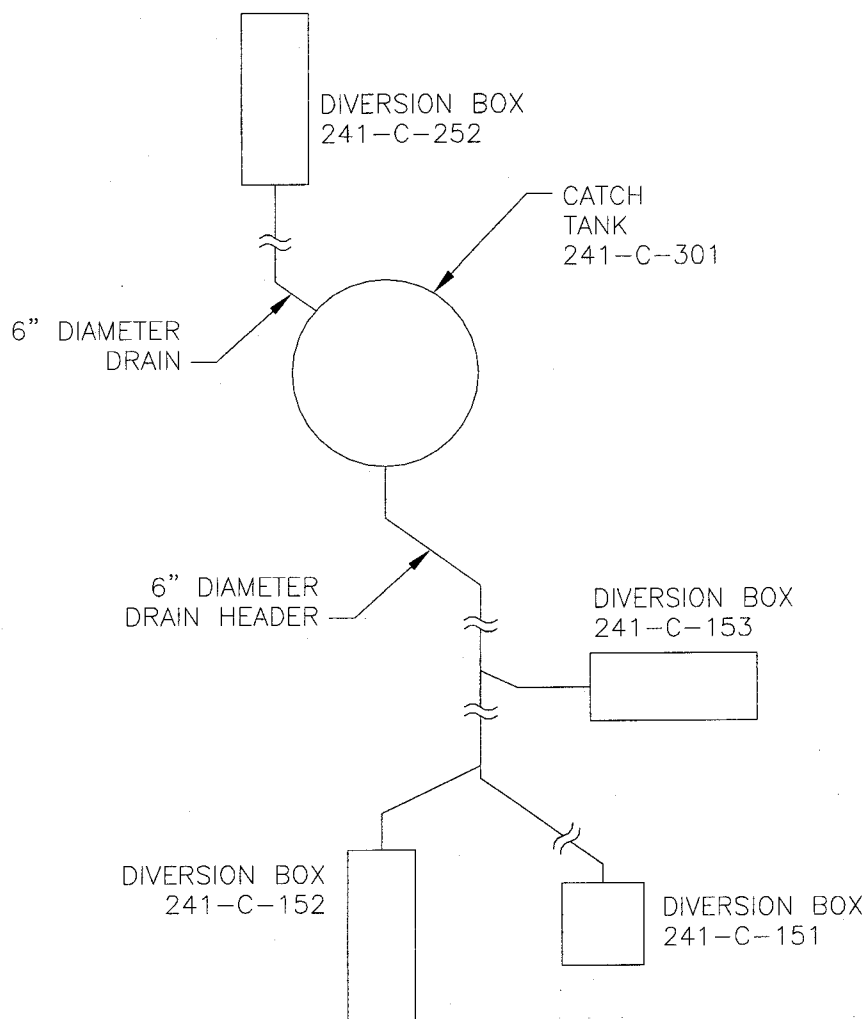
**Figure 2. Catch Tank and Diversion Boxes.**

The catch tank is located underground and has an inside diameter of 20 feet. The operating fill level of the tank is 15 feet. The approximate operating volume of the tank is 36,000 gallons. The tank has a domed roof and flat bottom. The entire bottom surface of the tank is not flat. The flat portion of the tank has a 14-foot diameter. The outer three feet along the perimeter of the bottom surface is sloped up to the wall with a radius that forms a lower knuckle region at the base of the tank wall. The approximate distance from the bottom of the tank to the top of the dome is 19 feet. The top of the tank dome is located approximately 10 feet below grade level. The 300-series catch tank is made of reinforced concrete with an interior application of gunite. The base of the tank walls are 6 inches thick and taper to 5 inches thick at the top of the wall. The tank dome is 6 inches thick. The bottom slab of the tank is 5-3/4 inches thick. The tank thicknesses noted include the 3/4 inch thick gunite cover coat that was applied to the tank interior surface after the reinforced concrete structure cured. A layer of wire mesh may have been installed between the concrete and gunite along the tank walls. The wire mesh layer is noted as being for construction purposes only and at the option of the contractor on the catch tanks original fabrication drawing.

The poured concrete had a 2,500 pounds-per-square-inch (psi) minimum 28 day compressive strength requirement. The gunite layer had a 5,000 psi minimum 28 day compressive strength requirement. The 300-series catch tank lacks the carbon steel lining similar to the larger capacity 100-series and 200-series single-shell tanks (SST) (Blue Print File 74650, 4 Catch Tanks BLDG #241 Hanford Engineering Works).

Figure 3 depicts the general configuration of the catch tank. The catch tank has no pit structures located at grade level providing access to the catch tank. The tank has eight risers that extend approximately 1-1/2 feet above grade level. The above grade risers provide direct access to the catch tank below. The risers are fabricated from schedule 40 carbon steel pipe and extend into the dome space of the catch tank one foot. The risers are located on an 8-1/2 foot radius as measured from the center of the tank. The risers are spaced two feet apart as measured from the center line of the riser. The risers are not located above the flat portion of the tank bottom due to the lower knuckle transition between the tank wall and bottom. The risers are located above the lower knuckle region. The area directly below the risers is elevated approximately 3 inches above the flat bottom region of the tank due to the lower knuckle construction.

**Figure 3. Catch Tank Configuration.**

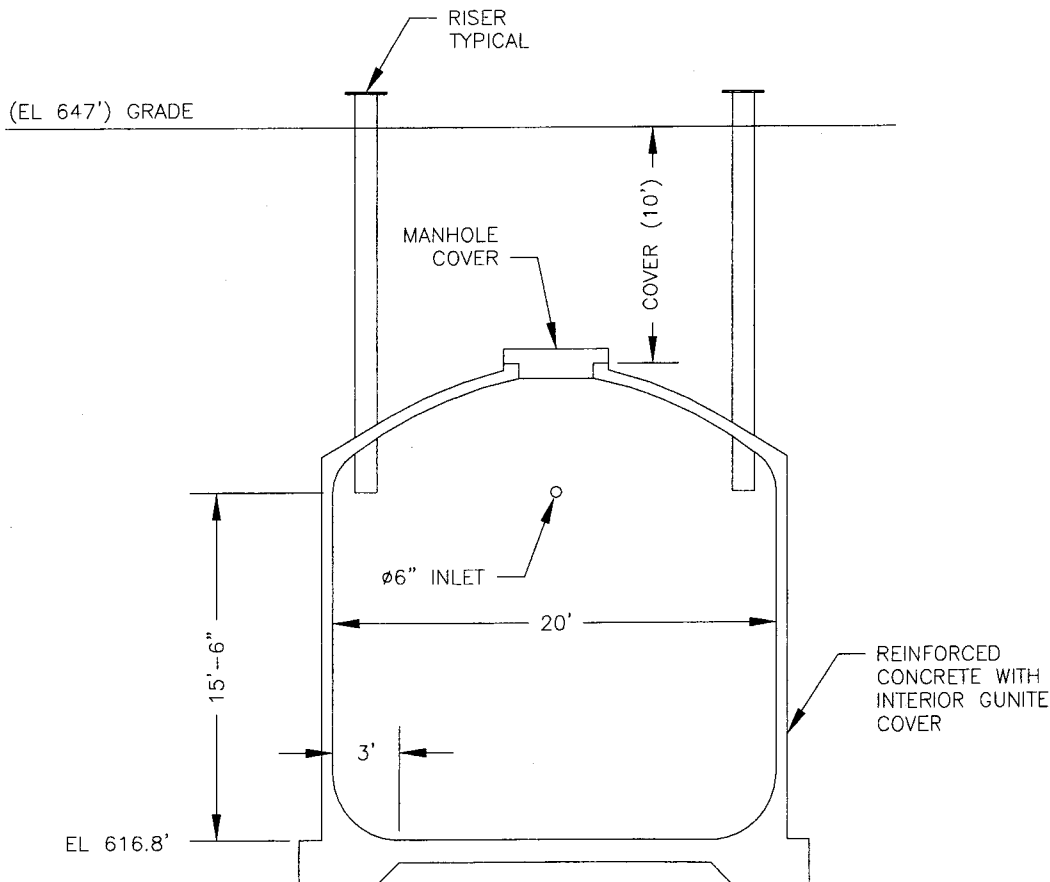
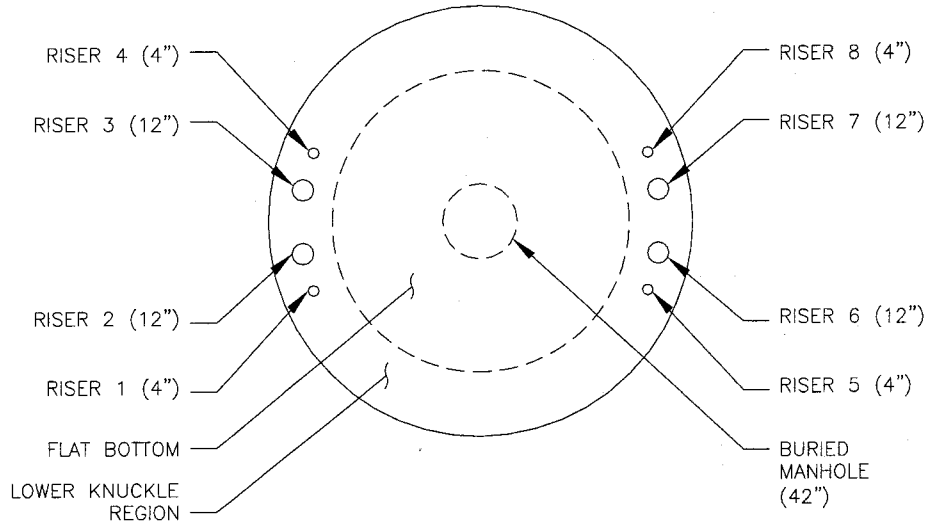

Figure 4 depicts the catch tanks riser numbers, diameters, location, flat bottom area, lower knuckle region and includes the buried manhole located in the center of the tank.

**Figure 4. Catch Tank Riser Layout.**



Four of the above grade risers are 4 inches in diameter and the other four risers are 12 inches in diameter. Seven of the risers have blind flanges installed above grade level. Riser 5 contains a vapor tube assembly (H-2-85267, *Single Heated Vapor Tube Assembly*, and ECN 640456 *Vapor Sampling*). Table 1 identifies the configuration and elevation of the catch tanks eight above grade risers and the buried manhole.

**Table 1. 241-C-301 Riser Configuration.**

Riser Number	Riser Diameter (Inches)	Elevation (Feet)	Equipment
1	4	648.27	None
2	12	648.35	None
3	12	648.20	None
4	4	648.27	None
5	4	648.28	Vapor tube assembly (H-2-85267)
6	12	648.27	None
7	12	648.27	None
8	4	648.28	None
Buried manhole	42	637 (estimated)	None

H-2-1762, *Tank 241-C-301 Riser & Nozzle Elevs.*, Revision 1, Sheet 1, General Electric Hanford Works, Richland, Washington.

H-2-85267, *Single Heated Vapor Tube Assembly*, Revision 0, Sheet 1, U.S. Department of Energy, Richland, Washington.



A field walk down was performed on March 9, 2010 of the 241-C-301 catch tank above grade area. The walk down revealed no local above-grade equipment or structures near the catch tank. The edge of the catch tank is located approximately ten feet from the exterior fence that restricts access to the 241-C tank farm complex. Figure 5 shows the above grade configuration for Risers 1 through 4. Risers 1 and 4 are four inches in diameter and covered with blind flanges. Risers 2 and 3 are twelve inches in diameter and covered with blind flanges.

**Figure 5. Catch Tank Risers 1 Through 4.**



Figure 6 shows the above grade configuration for Risers 5 through 8. Riser 8 is four inches in diameter and covered with a blind flange. Risers 6 and 7 are twelve inches in diameter and covered with blind flanges. Riser 5 is four inches in diameter and contains an abandoned vapor tube assembly. The vapor tube assembly was used to collect vapor and gas samples from the catch tank on September 29, 1995. The results from this sample are not discussed in any detail in this report but are noted for informational purposes. Specific information regarding the sample can be found in (WHC-SD-WM-RPT-198, *Vapor and Gas Sampling of Single-Shell Tank 241-C-301 Using the Vapor Sampling System*).

A dome loading structural analysis for the catch tank has also been performed. The results of the analysis indicate that the catch tank can support a concentrated live load of 225,000 pounds in addition to soil and 40 pounds-per-square-foot uniform live load (RPP-16903, *Hanford Engineering Works Bld 241-T,U,B 20'-0" Dia. Catch Tank Arrangement and Concrete*). The allowable live load should be able to support the installation of retrieval equipment on or near the catch tank. Further review of the catch tank dome loading would be required after a specific method of retrieval is identified.



Figure 6. Catch Tank Risers 5 Through 8.



### 3.2 CATCH TANK 241-C-301 PROCESS HISTORY

Two 6-inch diameter drain lines enter the catch tank approximately 15-1/2 feet above the bottom of the tank. The drain lines leading to the catch tank are supplied from the four interconnected below grade diversion boxes. The 241-C-301 catch tank is assumed to contain the waste types involved in active 241-C tank farm waste transfers for the period 1949 to 1980 (WHC-SD-EN-ES-040, *Engineering Study of 50 Miscellaneous Inactive Underground Radioactive Waste Tanks Located at the Hanford Site Washington*).

The catch tank accumulated waste via leaking process connections or jumper drainage from the interconnected diversion boxes during its history of operation. Additionally, the catch tank received water from rainfall or snowmelt and accumulated windblown dust that entered the diversion boxes and washed into the catch tank via the two drain lines.

Few retrievable records exist prior to 1974 regarding the specific waste level in the catch tank. Appendix A (WHC-SD-WM-TI-356, *Waste Storage Tank Status and Leak Detection Criteria*) identifies the recorded liquid level and activities associated with the catch tank from 1974 up to the period of isolation in 1985. Of particular interest are the liquid transfers from the catch tank recorded for March 18, 1975; October 23, 1977 and lastly on June 3, 1985. Table 2 summarizes the three most recent transfers from the catch tank and includes the initial and final liquid levels associated with the pumping activities. Note should be given to the solids level measured following the pumping in June 1985 versus the reported final liquid level following pumping in October 1977. A substantial increase, approximately 27 inches (5,292 gallons), of solids can be

extrapolated between the pumping events for the catch tank. The exact cause of the level change is unknown but could be attributed to a different measurement method, change in reference points or the actual deposit of solids between 1977 and 1985. One possible cause for the increase in the catch tanks solids level could be attributed to the addition of collected rain water and flush water with windblown sand from cleaning the diversion boxes. Between the catch tanks liquid samples collected in 1974 and 1985 the pH level decreased from 9.3 to 7.4. Decreasing the pH level in typical 241-C tank farm waste from 9.3 to 7.4 would be expected to result in the precipitation of alumina compounds. This reaction alone does not explain the substantial increase in solids between 1977 and 1985.

**Table 2. 241-C-301 Liquid Levels and Pumping.**

Recorded Transfer Date	Initial Liquid Level (Inches)	Final Liquid Level (Inches)	Measured Solid Level (Inches)
March 18, 1975	100.0	25.25	Not Measured
October 23, 1977	79.25	18.75	Not Measured
June 3, 1985	128.0	53.5	46.0

WHC-SD-WM-TI-356, Revision 0, *Waste Storage Tank Status and Leak Detection Criteria*, Westinghouse Hanford Company, Richland, Washington.

RPP-RPT-42231, Revision 0, *Summary of Twenty-Five Miscellaneous Tanks Associated with the Single-Shell Tank System*, Washington River Protection Solutions LLC, Richland, Washington.

Liquid grab samples were collected and analyzed prior to the pumping of liquid from the catch tank in 1975 and 1985. Appendix B contains the available sample results for the catch tank liquid as obtained in 1974 (RPP-RPT-42231, *Summary of Twenty-Five Miscellaneous Tanks Associated with the Single-Shell Tank System*). Appendix C contains the available sample results for the catch tank liquid as obtained in 1985 (RPT-RPT-42231). No laboratory results are available for a liquid sample to support pumping in 1977. Table 3 summarizes the sample results with the units reported by the laboratory at the time of the sample. Note that the unit labels presented in Table 3 vary between the 1974 and the 1985 laboratory analyses.

**Table 3. 241-C-301 Liquid Sample Data.**

Sample Year	pH	Total Alpha	Total Beta	Cesium-137	Description
1974	9.30	0.0609 g/gal	1,700 $\mu$ Ci/gal	25,500 $\mu$ Ci/gal	Clear, yellow, no solids
1985	7.52	0.323 $\mu$ Ci/l	17,300 $\mu$ Ci/l	10,020 $\mu$ Ci/l	Clear, light green, no solids

g/gal = grams per gallon

$\mu$ Ci/gal = micro Curies per gallon

$\mu$ Ci/l = micro Curies per liter

The acquisition of current liquid and solid samples are necessary to support any future retrieval operations from the 241-C-301 catch tank. The result from the analyses impacts the ultimate design and deployment of the final catch tank retrieval system and transfer alternatives.

The catch tank was declared interim stabilized in June 1985 following the completion of the last pumping campaign. The basis for the declaration of interim stabilization was that the catch tank



contained less than 5,000 gallons of supernatant. A copy of the stabilization evaluation form is included as Appendix D (RPP-RPT-42231). The stabilization evaluation form reports a solids level in the catch tank equal to 3 feet 10 inches and a liquid level of 4 feet 5-1/2 inches. For the 20-foot diameter flat bottomed tank the reported solids level equates to 9,016 gallons assuming a completely flat bottomed tank. The reported liquid level equates to 1,470 gallons. The calculated liquids volume differs slightly from the volume of 1,421 gallons recorded on the stabilization evaluation form. The difference is attributed to a slight calculation or rounding error. The calculated tank volume assumes an entirely flat bottom to the tank and does not address the lower knuckle region of the catch tank depicted in the original contractor's fabrication drawings. Accounting for the lower knuckle region of the tank the waste volume of solids is approximately 500 gallons less than the reported volume. The currently reported waste volume in the catch tank is 10,470 gallons (HNF-EP-0182, Revision 265, *Waste Tank Summary Report for Month Ending April 30, 2010*).

The waste level in the catch tank has not been monitored since 1985. The four connected diversion box structures were isolated and weather covered prior to the completion of the last pumping campaign from the catch tank. The acquisition of liquid and solid samples from the catch tank are being pursued. Updated liquid and solid waste levels should be measured when samples are obtained from the catch tank. If the waste level of the catch tank has increased from the 1985 level, then the most likely cause could be attributed to rainwater intrusion. In the event the liquid level is substantially less, or missing, then a leak from the tank would be suspected and the tank integrity would be considered compromised. The potential for evaporative losses from the tank are minimal since the tank is sealed and there is no ventilation, either passive or active. The integrity of the catch tank would influence the selected method of retrieval.

## 4.0 RETRIEVAL BACKGROUND

### 4.1 RETRIEVAL CRITERIA

The established retrieval criteria for SSTs are as defined in the Tri-Party Agreement, Milestone M-045-00 (HFFACO, *Hanford Federal Facility Agreement and Consent Order*).

*“Closure will follow retrieval of as much tank waste as technically possible, with tank waste residues not to exceed 360 cubic feet in each of the 100 series tanks, 30 cubic feet in each of the 200-series tanks, or the limits of waste retrieval technology capability, whichever is less. If the DOE believes that waste retrieval to these levels is not possible for a tank, then DOE will submit a detailed explanation to EPA and Ecology explaining why these levels cannot be achieved, and specifying the quantities of waste that the DOE proposes to leave in the tank. The request will be approved or disapproved by EPA and Ecology on a tank-by-tank basis...”*

These established residual waste volumes are for the 100-series and 200-series tanks. The 100-series SSTs are 75 feet in diameter, carbon steel lined with a reinforced concrete shell and are dished bottom with the exception of those in the 241-A and 241-AX tank farms. Three hundred and sixty cubic feet of residual waste equates to a volume of 2,690 gallons. The 200-series SSTs are 20 feet in diameter, carbon steel lined with a reinforced concrete shell and

are dished bottom. Thirty cubic feet of residual waste equates to a volume of approximately 225 gallons.

The 300-series catch tanks are 20 feet in diameter but lack the carbon steel inner tank structure and the fully dished bottom as compared to the 200-series SSTs. There is currently no residual waste volume criterion established for the retrieval of the 300-series catch tanks. The 20-foot diameter interior catch tank results in an approximate volume of 196 gallons per inch, for the area of the tank above the lower knuckle before the transition to the flat bottom. The 14-foot diameter flat bottomed region of the 300-series catch tank results in approximately 100 gallons of residual hold up in the first inch of tank height. For the purpose of this engineering study the retrieval criteria is assumed to be based on the design and operation of any selected waste retrieval technology to the maximum extent technically and economically practical. Following sampling and analysis of the solids inventory in 241-C-301, the characteristics of the waste may be used to establish alternate (e.g., risk based) retrieval criteria.

Waste retrieval technology selection for C-301 will be a function of two primary criteria that include: 1) the integrity of the tank, and 2) how much waste needs to be removed from the tank. Defining these two criteria will require investigation of the in-tank conditions along with characterization of the tank contents. Both of these criteria are discussed further in Section 7.0.

#### 4.2 PAST 301-SERIES CATCH TANK PUMPING

Pumping of the 241-U-301 catch tank was performed in December 2003. The 241-U-301 catch tank is of a similar design to the 241-C-301 catch tank. The 241-U-301 catch tank received drainage from the 241-U-151, 241-U-152, 241-U-153, and 241-U-252 diversion boxes. The scope of the 2003 pumping campaign was limited to the removal of liquids with no effort to retrieve the settled solids inventory. The pre-pumping waste volume of the catch tank was 8,192 gallons (HNF-EP-0182, Revision 188, *Waste Tank Summary Report for the Month Ending November 30, 2003*). The current waste level is reported as 1,450 gallons (HNF-EP-0182, Revision 265, *Waste Tank Summary Report for the Month Ending April 30, 2010*). Approximately 6,700 gallons of liquid was transported via an over ground tanker to the 241-SY double-shell tank (DST) farm for offload.

The dose rate for the 241-U-301 liquid grab samples were approximately 3 mRad/hour (HNF-SD-WM-DP-291, *Waste Compatibility Safety Issues and Final Results for Tank U-301-B Grab Samples*). Updated liquid and solid samples need to be collected from 241-C-301 to support any future retrieval operation. The transportation of solids in the over the road tanker is undesirable as the tankers on the Hanford Site are designed and licensed for liquid transportation. Tankers were recently used for the pumping of liquids from catch tanks 240-S-302 and 241-UX-302A. In both of these pumping operations in-line filters were installed to restrict the passage of solids from entering the tanker.

The use of an over the road tanker truck is not considered as a viable option for the retrieval of catch tank 241-C-301 due to the inability to transfer solids. Partial retrieval of the catch tank liquid could be performed but is not considered practical. The catch tank contains approximately 1,500 gallons of liquids and approximately 9,000 gallons of solids. The majority of the tank waste requires the installation of a retrieval system capable of transferring solids and the installation of two independent systems is not considered practical.

### 4.3 VACUUM RETRIEVAL

Retrieval of the four C-200 series SSTs was performed between July 2004 and December 2006. The 200-series tanks are 20-foot diameter, dished bottom, steel lined tanks with reinforced concrete walls. The bottoms of the tanks are located approximately 37 feet below grade. The 200-series tanks have an operating volume of approximately 55,000 gallons. The retrieval of the four C-200 series tanks was completed using a vacuum retrieval system (VRS). The VRS was comprised of an in-tank articulating mast, above grade vacuum skid, above grade vessel/pump skid, portable exhauster and other support equipment.

The articulating mast is hydraulically driven and has a vacuum head that could be rotated, extended, and retracted as necessary to reach waste locations. The vacuum head had five high pressure water scarifying nozzles used to dislodge waste. The high pressure water system was rated for up to 3,000 psi but was operated at a variable rate between 300 psi and 1,800 psi during the retrieval campaigns. The waste from the tank being retrieved was collected in the vessel/pump skid. The slurry vessel in the deployed VRS had a 250 gallon capacity. Later versions of the vessel/pump skid increased the operating volume of the slurry vessel to 400 gallons. The waste from the slurry vessel was transported to DST 241-AN-106, via Hose-in-Hose Transfer Line (HIHTL) using progressive cavity pumps located inside the vessel/pump skid. The transfers were performed in individual batches. Following the transfer of waste to the DST the slurry vessel was filled with raw water and pumped to perform transfer line flushes. The frequency of the transfer line flushes ranged from following every batch to once per operating day.

The vacuum head of the articulating mast and the vessel/pump skid are connected to the vacuum pump skid. The vacuum skid contains a water/gas separator and two liquid-ring vacuum pumps used to create the motive force to lift the waste into the slurry vessel. The air stream is returned back to the tank being retrieved and again through the vacuum skid with a portion being exhausted to atmosphere with a portable exhauster connected to the tank.

The portable exhauster circulates the tank atmosphere and discharges monitored and filtered air to the environment. The portable exhauster helps to maintain in-tank viewing and prevents the accumulation of vapors and gases in the dome space created by the waste disturbing operation. All completed and currently active SST retrievals have utilized active ventilation as provided via the portable exhausters. Figure 7 depicts the VRS as deployed for waste retrieval of the C-200 series tanks.

Figure 7. Vacuum Retrieval System Schematic.

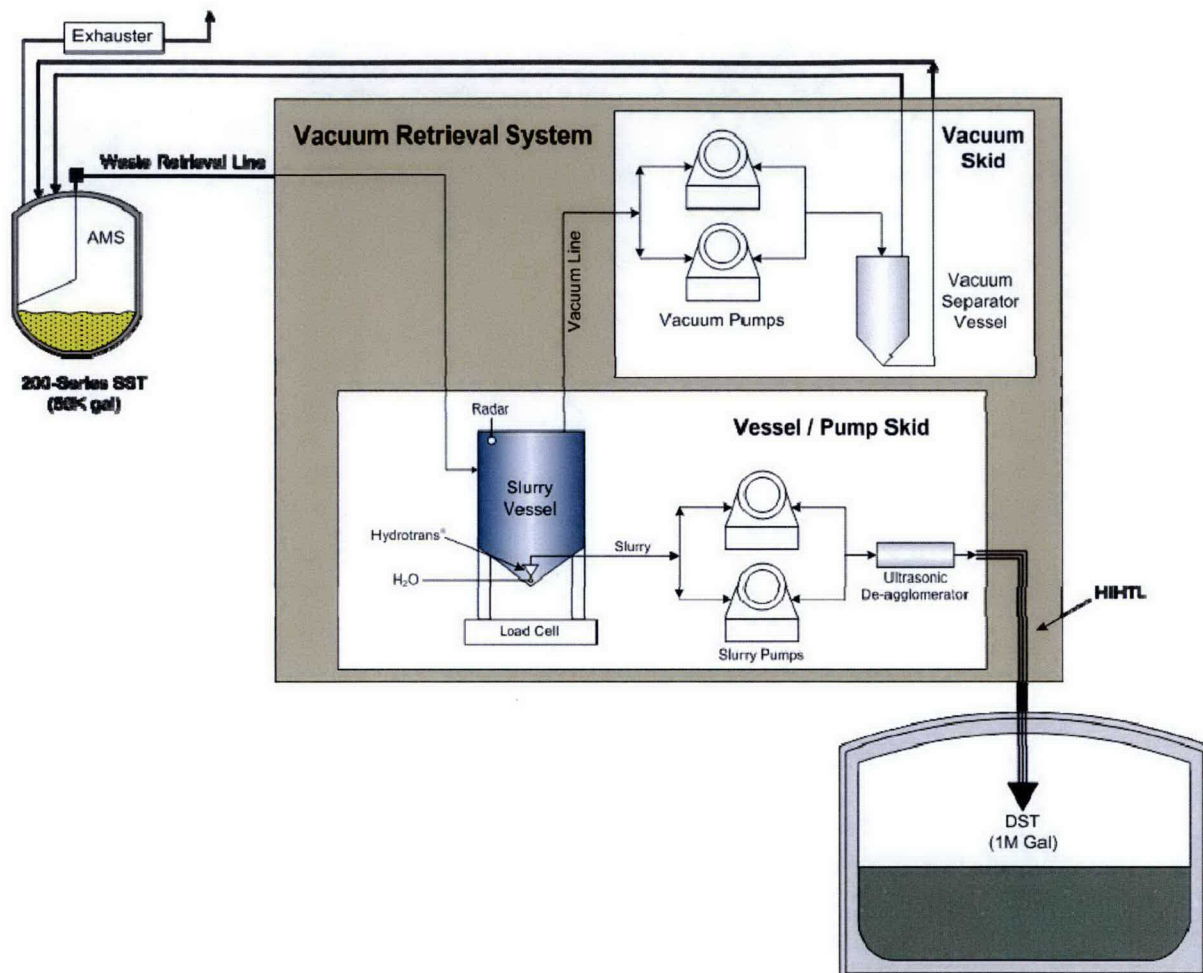

Table 4 summarizes the results from the four completed C-200 retrieval campaigns using the VRS. The waste type for all four tanks was classified as sludge. The order of the retrievals for the four tanks was performed in the following sequence: 241-C-203, 241-C-202, 241-C-201, and 241-C-204. The retrieval of waste from the C-200 tanks was performed to achieve the limits of the technology. Review of the waste retrieval data reveals that approximately 95 percent of the tank waste was retrieved within the first two-thirds of the operating days. The remaining one-third of the operating campaign was spent to achieve the limits of the VRS technology after the retrieval criteria for the residual tank waste volume of 30 cubic-feet was neared.

**Table 4. C-200 Vacuum Retrieval Summary.**

Tank	Waste Retrieved (gallons)	Residual Waste (gallons)	Water Used (gallons)	Total Batches	Waste Per Batch (gallons)	Operating Days	Calendar Days	Operating Efficiency (Operating/Calendar) (percent)
C-203	2,501	139	62,661	188	13	34	266	13
C-202	1,253	147	13,414	47	26	18	43	42
C-201	690	144	31,784	128	5.4	33	149	22
C-204	1,367	137	45,432	201	6.8	37	143	26
Average	1,453	142	38,323	141	12.8	31	150	26

RPP-RPT-26475, Revision 1-A, *Retrieval Data Report for Single-Shell Tank 241-C-203*, CH2M HILL Hanford Group, Richland, Washington.

RPP-RPT-29095, Revision 0, *Retrieval Data Report for Single-Shell Tank 241-C-202*, CH2M HILL Hanford Group, Richland, Washington.

RPP-RPT-30181, Revision 0-B, *Retrieval Data Report for Single-Shell Tank 241-C-201*, CH2M HILL Hanford Group, Richland, Washington.

RPP-RPT-34062, Revision 0, *Retrieval Data Report for Single-Shell Tank 241-C-204*, CH2M HILL Hanford Group, Richland, Washington.

Initial waste retrieval from 241-C-203 was favorable as the waste behaved similar to the simulant used during system testing at the Hanford Cold Test Facility. As the campaign progressed the waste broke into chunks with a gravel appearance. This material required considerably more effort to be lifted out of the tank and remain suspended through the retrieval system (RPP-RPT-26475, *Retrieval Data Report for Single-Shell Tank 241-C-203*). Lessons learned from the 241-C-203 retrieval were implemented in the subsequent VRS operations and helped improve operating efficiency and reduce the total volume of water needed.

The 241-C-202 retrieval operations were completed without any major events or delays (RPP-RPT-29095, *Retrieval Data Report for Single-Shell Tank 241-C-202*).

Vacuum retrieval at 241-C-201 was impacted by hydraulic hose issues and troubles with the hydraulic rotation of the articulated mast which added to the total number of days required (RPP-RPT-30181, *Retrieval Data Report for Single-Shell Tank 241-C-201*).

The retrieval campaign at 241-C-204 was impacted by an in-tank leak on the high pressure scarifier, articulating mast rotation trouble shooting and repair, DST exhaustor issues and freezing lines within the vacuum and vessel/pump skids (RPP-RPT-34062, *Retrieval Data Report for Single-Shell Tank 241-C-204*).

An extended amount of down time was encountered during the 241-C-203 retrieval due to general tank farm safety concerns. Delays in the 241-C-201 and 241-C-204 retrievals were attributed to articulating mast issues. It is unlikely that either of those items would have much of an impact if the VRS was deployed at 241-C-301; however it is impossible to determine if a similar unknown issue could arise and impact the operating efficiency if a VRS was deployed at 241-C-301. The operating efficiency and retrieved waste per batch from the four C-200 operating campaigns are averaged to create an estimate for projecting catch tank 241-C-301 operation data. Catch tank 241-C-301 contains approximately 1,500 gallons of liquid, where the C-200 tank waste was



entirely sludge. For estimating purposes the 1,500 gallons of catch tank liquid are assumed to be retrieved within the first four batches and this volume is not included in the projected waste per batch retrieval rate. The remainder of the catch tank waste is conservatively estimated to act similar to the C-200 tanks. Table 5 compares the average C-200 VRS campaign and estimates values for the retrieval performance of catch tank 241-C-301 performed to the limits of the VRS technology.

**Table 5. Catch Tank 241-C-301 Vacuum Retrieval Estimate.**

Tank	Waste Retrieved (gallons)	Residual Waste (gallons)	Water Used (gallons)	Total Batches	Waste Per Batch (gallons)	Operating Days	Calendar Days	Operating Efficiency (percent)
C-200 Average	1,453	142	38,323	141	12.8	31	150	26
C-301	10,320	< 150	272,200	436 <sup>2</sup>	20.5 <sup>1,2</sup>	64 <sup>3,4</sup>	164 <sup>4</sup>	39 <sup>4</sup>

<sup>1</sup> The calculated 241-C-301 waste per batch does not include the estimated retrieval of 1,470 gallons of tank liquid assumed to be retrieved during the first four batches.

<sup>2</sup> Waste per batch and the total number of batches are modified to address the increase in batch vessel volume from 250 gallons to 400 gallons.

<sup>3</sup> Operating days are based on comparison to the C-200 retrieval ratio where 31 days were required to retrieve 141 batches of tank waste.

<sup>4</sup> For estimating purposes a one and a half times increase in system operating efficiency is assumed versus the C-200 average. The improvements are attributed to the seven foot shorter height the vacuum system is required to lift waste and the capitalization of the C-200 lessons learned. The increase in operating efficiencies reduces the operating days and calendar days by 33 percent.

The effectiveness of the vacuum system is largely dependent upon the physical characteristics of the solid waste. If the majority of the solids are colloidal or light particles the vacuum system should be capable of transferring them to the vessel/pump skid without issue. The effectiveness of the vacuum system is negatively impacted if the solids are comprised of hardpan sludge containing large waste particles or entrained debris. The estimated days of operation of the VRS in the catch tank are based upon operating the system similar to the C-200 retrievals by reaching the limits of technology. Retrieval data from the C-200 tanks shows that nearly 95 percent of the tank waste can be retrieved within the first two-thirds of the operating campaign. The establishment of retrieval criteria for the 241-C-301 catch tank residual waste volume may impact the projected duration of an operating campaign using a VRS.

The C-200 VRS was abandoned in place in early 2007 following the completion of the retrieval of the final C-200 tank. The four in-tank articulating masts and grade located vacuum skid and vessel/pump skid remain positioned in or by the C-200s. Although the C-200 VRS is physically located nearby catch tank 241-C-301, it's proximately is too far for effective operation of the slurry line between a catch tank articulating mast and the slurry vessel. The minimization of this distance and the elimination of pee traps are some of the primary lessons learned during the retrieval of the C-200 series tanks. Effective deployment of a VRS would require relocation closer to 241-C-301 for optimal performance.

Two identical VRS systems were procured and were planned to be deployed for vacuum retrieval from the B-200 and U-200 series tanks. The deployment and waste retrieval from these tanks has been postponed. One of the uncontaminated VRS vacuum skids is being used for proof-of-concept

testing for the Mobile Arm Retrieval System (MARS). The other spare VRS is not currently planned for field deployment. One of the spare VRS could be deployed at catch tank 241-C-301, unless it is eventually reassigned elsewhere. The acquisition of a new VRS is also an option if vacuum retrieval is determined the best path forward for catch tank retrieval.

The installation of a new or spare VRS system should take into consideration the lessons learned through the course of the operation of the C-200 vacuum system (RPP-29413, *Tank 241-C-200 Vacuum Retrieval Lessons Learned: Opportunities for Refinement of Future Retrieval Operations*). Taking into consideration the lessons learned from the first deployment of the vacuum system should improve the performance and operating efficiency if a vacuum system is selected for the retrieval of the 241-C-301 catch tank.

#### **4.4 MODIFIED SLUICING**

Modified sluicing has recently been performed to retrieve bulk waste from four 100-series SSTs in the 241-C tank farm; 241-C-103, 241-C-108, 241-C-109 and 241-C-110. Modified sluicing augmented with an in-tank remote vehicle, telescopic sluicers or robotic arm is planned to continue for the remainder of the 100-series tanks to complete the retrieval of all the 241-C tank farm SSTs prior to the 2014 Consent Decree Milestone.

The sluicing process is based upon the principle that fine particles can be suspended in a solution and carried with the fluid if there is sufficient momentum to maintain the heavier solid particles in suspension. The process is performed by the use of sluicers installed through the tanks peripheral risers. Two opposing sluicers have typically been installed in the 241-C tank farm retrievals due to the configuration of these 100-series SSTs. The installation of more sluicers is dependent upon the SST riser configuration and the need to support the installation of other retrieval support equipment.

Modified sluicing uses recycled DST supernatant as the motive force to break up and mobilize tank waste towards the central retrieval pump location. The slurry is then transported back into the DST via the retrieval pump located in the SST. The heavier solids settle in the DST and are not returned to the SST being retrieved. The DST pump supplying the recycled supernatant back to the SST decants the clearer liquid from the upper region of the DST.

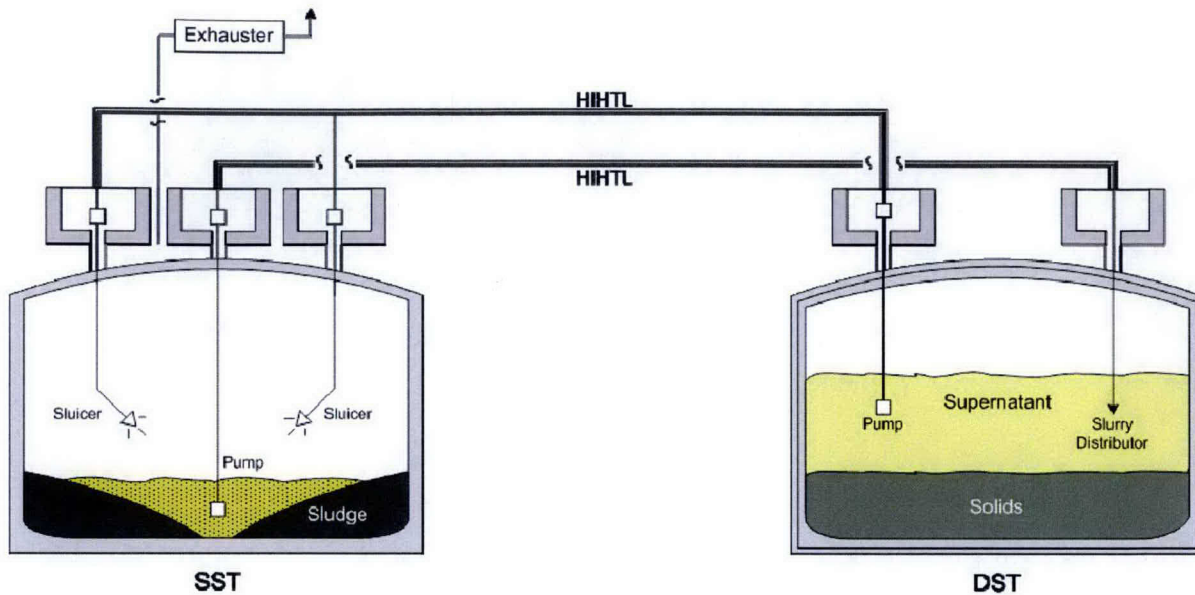
**Figure 8. Modified Sluicing Retrieval Schematic.**

The utilization of recycled DST supernatant as the motive force for the sluicing of solids in catch tank 241-C-301 is not considered practical for the purpose of this study. The radiological and chemical concentrations of typical DST supernatant are more hazardous than the anticipated catch tank liquid and solid inventory. The application of recycled DST supernatant into a catch tank lacking a steel liner may prove to be problematic. The sluicing operation to retrieve the catch tank solids material assumes the use of raw water as the sluicing media in the absence of catch tank sample data.

Modified sluicing has recently been deployed at multiple 100-series tanks located in the 241-C tank farm complex. Retrieval operations for tanks 241-C-108, 241-C-109, and 241-C-110 have not yet met the target criteria of 360 cubic feet of residual waste. The final retrieval data reports for those tanks have not been issued. Tank 241-C-103 was retrieved to meet the 360 cubic foot criteria via modified sluicing. Table 6 contains a summary of the retrieval data from the modified sluicing operations performed at 241-C-103.

**Table 6. Retrieval Data Summary Tank 241-C-103 Modified Sluicing.**

Tank	Waste Retrieved (gallons)	Residual Waste (gallons)	Water Used (gallons)	Recycled Supernatant (gallons)	Retrieval Rate (gallon waste per gallon of slurry)	Operating Days	Calendar Days
C-103	74,460	2,528	66,378	2,230,258	0.031	54	290

RPP-RPT-33060, Revision 0, *Retrieval Data Report for Single-Shell Tank 241-C-103*, CH2M HILL Hanford Group, Richland, Washington

Approximately ninety percent of the tank waste was retrieved within the first 24 operating days of the retrieval campaign. The rate of waste retrieval significantly decreased after the first 24 days of operation as the limits of the sluicing technology were being reached. The total number of calendar days for the retrieval operation was negatively impacted by the following issues:



resource constraints (23 days), failed slurry pump replacement (87 days), sluicer replacement (28 days), and sampling difficulties (28 days). Two thirds of the recorded water used was at the final stages of the retrieval for performing rinsing and sampling operations at 241-C-103 (RPP-RPT-33060, *Retrieval Data Report for Single-Shell Tank 241-C-103*).

Catch tank 241-C-301 contains approximately 1,500 gallons of liquid, where the 241-C-103 waste was entirely sludge. For estimating purposes, the 1,500 gallons of catch tank liquid are assumed to be retrieved within the first hour of operation with a submersible pump. Following the removal of the pumpable liquid it is assumed that the remainder of the catch tank volume is retrieved with twice the efficiency of the 241-C-103 retrieval. This increase in efficiency is credited with the anticipated low strength of the settled solids as compared to the process waste sludge in the 100-series tank. The waste retrieval from the catch tank is assumed to be performed to the limits of the technology as limited by the pump placement above the lower knuckle region of the tank.

Table 7 extrapolates the 241-C-103 modified sluicing results and creates estimated values for the retrieval of catch tank 241-C-301 to the limits of the technology using sluicing with raw water as the media. Note that the residual waste level in the tank is approximately 110 cubic feet (825 gallons), as limited by the placement of the pump in the lower knuckle region, and may exceed the final retrieval criterion once it is established.

**Table 7. Catch Tank 241-C-301 Sluicing Retrieval Estimate.**

Tank	Waste Retrieved (gallons)	Residual Waste (gallons)	Raw Water Sluice Volume (gallons)	Retrieval Rate (gallon waste per gallon of slurry)	Operating Days	Calendar Days
C-301	9,645	825	131,370 <sup>1</sup>	0.062	7 <sup>2</sup>	21 <sup>3</sup>

<sup>1</sup> The volume of water excludes transfer line flushes and any final rinsing and sampling of the catch tank. Water usage is determined by using the projected retrieval rate of remaining waste excluding the residual waste volume and the initially pumped liquid volume.

<sup>2</sup> Operating days are based on comparison to the 241-C-103 retrieval ratio where 54 days were required to retrieve 74,460 gallons of tank waste.

<sup>3</sup> Due to the short anticipated operating duration of the retrieval the equipment problems encountered at 241-C-103 are not anticipated and a 33 percent operating efficiency is assumed.

The submersible pumps deployed in the recent 241-C tank farm retrievals are located in the center of the tank. The 100-series SSTs were built with a dished bottom that slopes to the central location. The placement of the pump in the center of the tank places the pump inlet at the lowest possible location and results in the minimization of residual waste.

If a sluicing system was deployed at the 241-C-301 catch tank it would likely rely on the use of a single low to medium pressure raw water sluicer deployed in one of the peripheral risers and a submersible pump located in an opposite riser. The pressure used in the sluice stream would need to be selected to prevent damaging the gunite coating on the inside tank wall and bottom of the catch tank.

The installation of a submersible pump in the catch tank would be through an above grade riser located at the periphery of the catch tank. The bottom of the catch tank was designed and

fabricated flat in the center and has a lower knuckle region between the wall and the floor of the tank that extends inward approximately 3 feet from the wall. The catch tank has a 20-foot internal diameter. The flat bottom portion of the catch tank has an approximate 14 foot internal diameter. The waste volume per inch above the lower knuckle region of the tank height equates to 196 gallons. The volume of waste held up for the bottom inch of the flat bottomed portion is approximately 100 gallons. Table 8 lists the approximate residual waste in the lower knuckle region of the tank at specific depth levels. The volumes are extrapolated from a reconstruction of the lower knuckle region of the tank as redrawn from the original tank fabrication drawing (Blue Print File 74650).

**Table 8. Catch Tank 241-C-301  
Residual Waste Volume Levels.**

Residual Depth (Inches)	Volume (gallons)	Volume (cubic-feet)
1	100	13.4
2	220	29.4
3	350	46.8
4	500	66.8
5	660	88.2
6	825	110.3
7	995	133.0
8	1,170	156.4

The peripheral location of the risers places them above the lower knuckle region of the tank. The floor of the tank directly below the tank risers is approximately 3 inches above the flat bottom region of the tank. If the allowable residual waste level in the catch tank is determined to be 30 cubic feet, similar to the residual waste in the 200-series SSTs, a typically deployed retrieval submersible pump would be unable to draw a free liquid surface down to a residual waste level capable of satisfying this retrieval criterion. Three inches of free liquid in the tank equates to a residual volume of approximately 350 gallons. The typically deployed submersible pumps are incapable of pumping a tank completely empty due to the configuration of the pump inlet and location of the impeller, or first stage of the pump. A residual level between three to four inches is customary. If a vertical pump assembly was deployed through a peripheral riser and allowed to rest on the lower knuckle portion of the tank the residual free liquid height in the catch tank would be approximately 6 to 7 inches (825 gallons to 995 gallons).

As shown in Figures 3 and 4 there is a manhole cover located in the center of the tank. This could be used to provide access into the center of the tank. Access through the manhole in the center of the tank would require the installation of a large riser/caisson from the ground surface down to the top of the tank, removal of the manhole cover, construction of a concrete pad and riser structure at the surface to support any equipment that would be installed in the tank. Since both the vacuum and modified sluicing systems can be installed through existing risers, the installation of a new riser was not evaluated in detail.

The recent 241-C tank farm retrievals began operations with a commercially available electrical powered submersible pump. The pump inlet was modified to use a different inlet screen material and lowered to achieve the lowest possible residual waste volume. The submersible pump has the ability to pump a free liquid surface down to approximately 3 inches assuming the impeller of the pump is submerged at onset. If the liquid surface is below the impeller of the pump the volume in the tank must be increased to a level above the impeller to begin transferring material. The most recent 241-C tank farm retrievals have used a hydraulically driven vertical turbine pump due to the need for increased solids handling capability, increase transfer flow rate and pressure capabilities. The pump is installed on a mast that allows the pump inlet to be positioned within the top foot or two of the sluiced waste stream to maximize the transfer of solids to the DST. The overall height of the pump assembly is adjustable and is lowered towards the tank bottom as the waste volume in the tank is being retrieved. The hydraulically driven vertical turbine pump has the ability to pump a free liquid surface down to approximately 3 inches assuming the first stage of the pump is submerged. If the liquid surface is below the first stage of the pump the volume in the tank must be increased to a level above the first stage for the pump to begin transferring material. The installation of either of the pumps recently utilized to successfully retrieve waste via modified sluicing in the 241-C tank farm retrievals would leave a residual waste level in the catch tank above 30 cubic feet due to the location above the lower knuckle region. The pump would still leave in excess of 30 cubic feet due to the inability to draw liquid down to the approximate two inch level if the pump was located above the flat bottom region of the catch tank. Once an established retrieval criterion for the catch tank is formalized one of the existing pumps may be capable of meeting the retrieval target or assisting the overall retrieval. However, the goal is to retrieve as much waste as possible prior to the final closure of the catch tank and deployment of a typical pump through the peripheral riser will not maximize waste removal on its own.

The hard heel residual waste left behind when modified sluicing has reached the limits of technology has spawned a search for alternate pumps that may be implemented in future modified sluicing operations and also to address the residual waste levels with flat bottomed SSTs. The following activity is being pursued and may offer assistance to the retrieval of the 241-C-301 catch tank if suitable transfer pump alternatives are found (RPP-RPT-44139, *Hard Heel Waste Retrieval Technology Review and Roadmap*).

*An improved slurry pump for use with a vertically oriented, centrally located, sluice pumping system (i.e., modified sluicing configuration) would be capable of deployment through a 12 inch riser and would be able to pump waste from both sloped- and flat-bottom tanks (effectively pump down to below 1 inch above tank bottom). This system would likely be either (1) a two pump system, with the in-tank pump at or near the tank bottom, designed for sludge pickup and the other in-line pump located in tank or in an above-grade pump skid, to provide the pressure necessary for the waste transfer to the double-shell receiver tank, or (2) a Hanford specific pump capable of sludge removal with the effective power (head) to also transfer the waste to the double-shell receiver tank. Both of these pumps are under investigation as part of the FY 2010 baseline pump development effort. A decision on which pump or pump system will be developed will likely be made by the end of the third quarter of FY 2010 (RPP-RPT-44139).*

#### 4.5 MISCELLANEOUS CATCH TANK PUMPING

Catch tank 241-UX-302A was declared an assumed leaker in 2006. The below grade carbon steel catch tank received drainage from a local diversion box. In 2006 an air operated bladder pump was installed to the liquid inventory from the catch tank. The commercially available bladder pump was low flow and capable of a maximum flow rate of one gallon per minute. Approximately 900 gallons of liquid was recovered from the catch tank. The retrieved liquid was pumped through a filter and into a portable tanker truck and offloaded into 241-SY-102. The filter was used to prevent solids from being pumped into the tanker. The liquid was transferred using a single walled hose installed in sleeve material due to the low radiological and chemical inventory of the tank liquid sample (RPP-RPT-31779, *241-UX-302A Catch Tank Liquid Mitigation Completion Report*).

Catch tank 241-ER-311 was declared an assumed leaker in 2006. The below grade stainless steel catch tank received drainage from a local diversion box. Several alternatives were evaluated to address the options for removing the liquid from the catch tank. The tank contained approximately 400 gallons of liquid and some minor solids inventory. It was determined that the best alternative was to dry out the tank using evaporation as induced by the flow of a portable exhauster. The operations were initiated in 2006 and declared successful with the actual exhauster operating time taking considerably less than initially projected. The portable exhauster was operated approximately four months from October 2006 to February 2007 (RPP-RPT-29484, *Options for Responding to the Assumed Leak from Catch Tank 241-ER-311*).

Catch tank 240-S-302 was pumped in 2008 and the 241-UX-302A catch tank was pumped again following rainwater intrusion in 2009. Both catch tanks were pumped with identical pumping systems. Each system used a hydraulically driven submersible progressive cavity pump having a rated flow rate of 6 gallons per minute. The pumps were installed through riser extensions installed above the central pump pit caissons. The pumps had the ability to draw the liquid level down to a level of approximately 1/2 inch due to the nature of the progressive cavity pump. The above grade riser extension assembly allowed the pump to be lowered approximately six inches to allow liquid decanting at the onset of pumping operations and lowering of the pump inlet to the solids level at the completion of the campaign. Both catch tanks were pumped through a series of filters into a portable tanker truck and offloaded into 241-AP-106. The effectiveness of the filters was increased to be more restrictive than the initial pumping evolution performed at 241-UX-302A two years prior due to some minor solids carryover into the tanker. The liquid was transferred using a single walled hose installed in sleeve material due to the low radiological and chemical constituents in the liquid samples from both catch tanks. The liquid inventory pumped from 240-S-302 was approximately 6,900 gallons, while approximately 300 gallons was pumped from 241-UX-302A (RPP-RPT-42789, *Completion of Removal of Pumpable Liquid from 241-UX-302A*).

#### 4.6 OTHER CONSIDERATIONS

At the time of this report the retrieval of a flat bottomed tank on the Hanford site has not yet been performed. As a result, the design development of equipment to support the retrieval of the larger capacity 100-series flat bottomed tanks is not fully matured. Some of these activities are yet to be initiated and they are noted below for potential consideration as tools to support the

future retrieval of catch tank 241-C-301 depending upon the advancement in their design and performance through testing or installation in other retrieval systems.

#### **4.6.1 In-Tank Vehicle**

The use of a remotely operated in-tank track vehicle was deployed in SST 241-C-109. The track vehicle was designed to enhance the retrieval capabilities of the typically deployed modified sluicing system. The vehicle was equipped with a blade to push waste towards the pump inlet. The vehicle was also equipped with a high flow nozzle to be used to wash the tank walls with recycled supernatant to help reduce residual solids volume. The third feature of the track vehicle was to deliver a high pressure scarifying tool to break up hard heel material for mobilization. The track vehicle is designed to be deployed through a 12-inch diameter riser. The vehicle was tested extensively at the Hanford Cold Test Facility prior to deployment into 241-C-109. In 241-C-109 the vehicle worked well until it was operated outside of its design parameters. One of the tracks became dislodged in the tank and the vehicle was eventually abandoned in place. A new vehicle is being designed and built to perform similar functions as the first due to the early promise the vehicle showed and the advancement of the design concept. Improvements to the track mechanism will be incorporated to aid in the prevention of the failure mode encountered following deployment at 241-C-109. The design advancement of the in-tank vehicle was selected as a preferred option to support the retrieval of hard heel waste (RPP-RPT-44139).

The in-tank vehicle was installed in a tank composed of a limited inventory of saturated sludge. This allowed the operation of the vehicle to be performed with visual observation from the in-tank camera system. The installation of the in-tank vehicle into a tank where the vehicle could sink to the bottom or partially submerge is beyond the design parameters of the vehicle. Additional design development of the next generation in-tank vehicle is planned to occur in late fiscal year 2010.

#### **4.6.2 Enhanced Articulating Sluicers**

A second enhancement to assist modified sluicing in the hard heel waste recovery is the development of articulating sluicers. Articulating sluicers will add the capability of moving the sluice nozzle up and down to follow the waste level as it decreases in the tank being retrieved. The sluice nozzle may also be designed to incorporate telescoping features that extend and retract the nozzle end. Both of the added movement features of the articulating sluicers will improve the placement proximity of the sluice media to the waste. This improvement should enhance the ability to maintain the solids in suspension towards the pump inlet and offer greater flexibility to reach areas where solids have collected at the edges of the tank (RPP-RPT-44139). Additional design development of the articulation sluicer is planned to occur in late fiscal year 2010.

#### **4.6.3 Eductor System**

Eductors have historically been used to transfer materials from tanks on the Hanford site. Eductors have the advantage of containing no moving parts and have the ability to draw in material which is conducive to achieving low residual volumes. An eductor installed on an in-tank vehicle was deployed to retrieve two tanks on the Savannah River Site in 2008. The system used ultra-high pressure water to power the educator used to recover solids for conveyance out of the tank. The



operation of the eductor required raising it above the liquid level periodically to pull air into the line and create three phase flow. Three phase flow is required to transfer waste to the receiver tank. Based upon operating experience gained in 2008 there are additional recommendations for the improvement of the deployed eductor system prior to consideration for redeployment (RPP-RPT-44139).

Use of an eductor system with three phase flow is not addressed in RPP-13033, *Tank Farms Documented Safety Analysis*. Hazard and accident analysis will have to be performed and a safety basis amendment may be required prior to deployment of a direct transfer eductor system to a DST. Alternatively, a new waste transfer system could be designed to receive the three phase, remove the air, and pump the slurry to the receiver tank.

An eductor based system is currently being tested as a part of the MARS. The system configuration includes an eductor and set of nozzles on the end of the long-reach arm. The eductor is used to mobilize waste and transfer it to a smaller separator tank mounted to the mast. A slurry pump located within the separator tank is then used to transfer the slurry out of the tank. Details on the prototype testing are provided in RPP-RPT-47539, *MARS Eductor Phase I Verification Test Report*. Adaptation of the MARS eductor system to the C-301 catch tank was not evaluated in detail because the cost and system complexity is significantly greater than the vacuum and modified sluicing systems.

#### **4.6.4 Low Residual Volume Pump**

An alternative to an eductor system for achieving a low residual waste volume is the use of a pumping system capable of leaving a residual inventory of one inch or less.

*The tank farm operating contractor is currently evaluating options for slurry pumps and pumping systems to be used for the planned deployment of the mobile arm retrieval system at 241-C-107. Pumps that are being investigated include different pump types, for example, positive displacement or dynamic pumps (such as centrifugal), and either electric motor or hydraulic motor driven. Combination pump systems are also being evaluated (e.g., low head solids pump to a booster progressive cavity pump, jet pump to an inline booster). A parallel effort is underway with pump vendors and industry pump experts to assist in identifying and evaluating pump options. It is anticipated that one or more options will be selected and additional testing will be performed with appropriate waste simulants to verify performance (RPP-RPT-44139).*

#### **4.6.5 Waste Transfer Route**

The waste transfer route out of the 241-C tank farm complex is an important consideration. Due to the physical location of the tank farm the nearest DST complex is 241-AN. Other nearby DST complexes includes both the 241-AY and 241-AZ tank farms. The recent modified sluicing of the 241-C tanks and vacuum retrieval of the C-200 tanks has sent waste to the 241-AN tank farm using above grade HIHTL. A typical HIHTL is comprised of a single walled hose installed inside a secondary single walled hose. The exterior of the secondary hose can be heat traced and insulated to maintain process temperature and provide freeze protection. The hose material offers chemical and radiological resistance to the process fluid. HIHTLs have a rated service life

of three years from the date that waste is first passed through the hose. The long runs of HIHTL from the 241-C tank farm uses multiple HIHTL sections connected together to form one assembled transfer route. The acceleration of retrieval activities from catch tank 241-C-301 may benefit in the potential utilization of the HIHTLs and above grade diversion boxes currently installed to support the ongoing 241-C tank farm 100-series tank retrievals. If the retrieval of catch tank 241-C-301 is delayed the service life of the existing HIHTLs will likely be exceeded and new HIHTLs, in excess of one thousand feet, will be necessary to support waste transfer of the catch tank out of the 241-C tank farm complex.

The closest 100-series SST to the 241-C-301 catch tank is 241-C-112. Modified sluicing operations are planned to begin in late 2010 and extend into 2011 for the 241-C-112 retrieval. Considerable cost avoidance and catch tank retrieval system simplifications could be gained by retrieving the contents of the catch tank into 241-C-112 prior to the completion of waste retrieval operations at 241-C-112. In the event that the 241-C-112 retrieval is completed prior to the retrieval of the catch tank, other SSTs in the 241-C tank farm could be considered as staging tanks. The transfer of the catch tank material, via an active SST retrieval could simplify the design of the catch tank retrieval system if the burden of transferring the waste uphill to a DST is removed. The recent pumping of nearly 16,000 gallons of low contaminated liquid from the 244-CR vault sumps to 241-C-104 was approved and completed while the 241-C-104 retrieval operations were underway. The pumping of the 244-CR sump liquids into 241-C-104 for their ultimate transfer to the DST system could be elaborated on to accompany similar management of the 241-C-301 catch tank waste inventory. The use of a specific 100-series tank in the 241-C tank farm is subjected to the retrieval schedule of both 241-C-301 and the remaining 241-C SSTs.

#### **4.6.6 Double-Shell Tank Volume**

Depending upon the raw water usage involved in the retrieval of catch tank 241-C-301 an additional evaporator campaign, or alternate method of DST volume reduction may be necessary to address the allotted DST space for miscellaneous underground storage tank (MUST) retrievals. The retrieval waste stream from the catch tank would have a relatively high waste volume reduction rate if ran through the evaporator. If large volumes of DST space are consumed using either the VRS or raw water sluicing than currently unplanned DST transfers and evaporator campaigns may be necessary if the retrieval of the catch tank is performed prior to the 2014 date for retrieval of SSTs from the 241-C tank farm. The volume impact to the DST system excludes any potential buffering of the retrieved material that may be necessary to maintain the pH of the DST waste within the established acceptance range.

*The inactive miscellaneous underground storage tanks (IMUST) are assumed to be retrieved into the DST system between October 2020 and October 2028, with a total volume of approximately 550,000 gallons of dilute supernatant and sludge. The disposition of the waste in the IMUSTs has not been determined, the composition of the waste is incomplete and uncertain, and the schedule for retrieval of the IMUSTs might require adjustment to accommodate DST space limitations. (ORP-11242, River Protection Project System Plan – Retrieve and Treat Hanford’s Tank Waste and Close the Tank Farms to Protect the Columbia River)*

## 5.0 CLOSURE

Closure of the 241-C tank farm waste management area is due for completion by June 30, 2019 per Milestone M-045-83 (HFFACO).

*The single-shell tank waste management areas (WMA) are expected to be closed as landfills pending determinations under NEPA and the RCRA Site-Wide Permit. Landfill closure will include placement of an engineered surface barrier over the WMA. All SST components, both TSD and past practice, that are located under the active footprint of a barrier will be closed as part of the WMA through development of a WMA closure plan application and subsequent selection of closure actions in the SST system portion of the Site-Wide Permit pursuant to the HFFACO Action Plan Appendix D Milestone M-045-00. In addition, components that are outside of the fence line but under the assumed effective edge of the WMA engineered surface barrier footprint, will also be closed as part of the WMA. A common risk assessment and barrier design will accompany the closure plan application for the entire WMA. Other closure actions besides barrier construction and operation that are specific to the individual SST components within the WMA (e.g., waste removal, void space filling) will also be developed as part of a WMA closure plan application (the closure plan application for WMA closure may consist of more than one application covering a set of SST components for the purpose of final WMA closure). (RPP-PLAN-41977, Single-Shell Tank System Component Identification and Proposed Closure Strategy)*

After the completion of waste retrieval operations, the residual waste remaining in catch tank 241-C-301 will need to be assessed. The volume, configuration, and characteristics of the residual material would be evaluated using an in-tank camera to establish the location and distribution of residual waste remaining in the catch tank. The methodology used would parallel the calculations performed for the C-200 series SST retrievals. The characteristics of the residual waste requires the collection and analysis of waste samples.

Sampling and analysis of the residual waste requires defining the data quality objectives and developing a sampling and analysis plan. These could be developed specifically for the 241-C-301 catch tank or adopted from existing C-200 series documents (RPP-23403, *Single-Shell Tank Component Closure Data Quality Objectives* and RPP-PLAN-23680, *Sampling and Analysis Plan for Residual Waste Solids in the C-200 Series Tanks*). Upon the completion of the sample analysis a residual waste inventory estimate would be developed and documented in a waste inventory report. The waste inventory report serves as the basis for risk and regulatory based closure decision making.

Once the necessary regulatory approvals are in place it is assumed that catch tank 241-C-301 would be closed by stabilizing with grout. Grout formulations documented in (RPP-RPT-41550, *Closure Demonstration Grout Test Report*) would be used for stabilizing the waste residuals and tank structure. Depending on characterization of the tank solids, stabilization grout may be placed into the tank first to stabilize residual waste inventory. Following the placement of the stabilization grout, the balance of the tank would be filled with a bulk fill grout formulation. The



bulk fill grout is designed specifically as a flowable fill material that self levels and provides sufficient strength to prevent long-term subsidence of the catch tank structure.

A concrete pumper truck located outside of the tank farm fence would be used to place grout into catch tank 241-C-301. The distance from the tank farm fence to the nearest periphery of the catch tank is approximately 10 feet. It is assumed that one of the four existing 12-inch diameter catch tank risers would be utilized for grout placement. Implementation of the closure operations for the catch tank involves tank preparation, grout placement, and closeout actions.

## **5.1 TANK PREPARATION**

Filling the catch tank with grout displaces air from inside the catch tank out to the atmosphere. It is expected that either a passive high-efficiency particulate air (HEPA) filter or a portable exhauster will be used during grout placement operations to mitigate air emissions. The preferred method would be to use a standard passive radial HEPA filter during grout fill operations rather than a portable exhauster to simplify the activity. Based on current waste retrieval requirements it is expected that active ventilation will be required during waste retrieval, however the ventilation requirements for grout filling have not been defined.

Equipment removal may be performed prior to the addition of the grout to the catch tank. There is currently an unused vapor tube assembly installed in Riser 5 that could be removed. Additionally, some of the ancillary retrieval equipment should be considered for removal if the risks are determined to be low consequence. The equipment installed to support waste retrieval operations will depend on the retrieval system selected for deployment. At a minimum a sluicing based retrieval system includes a pump, sluicer, and in-tank camera. A vacuum retrieval system requires the installation of the vacuum mast and a camera assembly. It is assumed that the waste contacting portions of the retrieval system installed in the catch tank are abandoned in place. The tank currently has four 12-inch diameter risers available for deployment of the retrieval system. The removal of in-tank retrieval equipment may not be necessary for the purpose of establishing access for placing grout in the tank, but is contingent upon the final deployed configuration of the retrieval system. During the design of the retrieval system considerations should be given to leave one of the 12-inch diameter risers available for closure support.

## **5.2 GROUT FILL OPERATIONS**

The placement of approximately three trucks of stabilization grout would be performed initially to stabilize any residual waste volume. The three 10 cubic-yard grout trucks would provide an equivalent depth of approximately 2-1/2 feet across the bottom of the tank assuming even distribution of the stabilization fill material.

An elephant trunk would be used on the end of the grout pump truck pipe and the free end would be inserted into an available catch tank riser approximately three feet. The stabilization grout mix would free fall from the end of the elephant trunk to the bottom of the catch tank. The elephant trunk would provide flexibility to accommodate movement of the end of the pump truck arm as the result of the surging created by the grout pump. To maintain contamination control the elephant trunk could be cut off and dropped into the tank at the end of each shift if necessary.

The balance of the catch tank volume would be filled with bulk fill grout. The bulk fill grout is an economical mix utilizing local materials for tank stabilization. The bulk fill mix will readily flow and be self leveling across the 20 foot diameter tank. Approximately fifteen trucks, at 10 cubic-yards each, would be required to fill the remainder of the catch tank to a level even with the bottom of the risers. Adding the grout fill material to the bottom of the risers would leave a void in the dome space approximately 3 feet high at the center of the catch tank due to the geometry of the catch tank and with the risers installed near the perimeter (see Figure 3).

Filling the entire dome space of the catch tank requires the installation of a vent line at the high point of the dome space, or adding grout at the high point. Placing the vent location at the center of the catch tank would require a filter and excavation or core drilling into the manhole cover. An additional three truckloads of bulk fill grout would be required to fill the tank dome space. The complete fill of the catch tank upon closure is not an established criteria but a target goal. Alternate grout introduction methods may be tested. However, without a high point vent located at the center of the catch tank the structure will retain some void space at the top of the dome roof.

There are two six inch diameter drain lines that penetrate the side of the catch tank at an elevation of 15 feet and 6 inches above the catch tank bottom. One drain header is supplied from the 241-C-151, 241-C-152, and 241-C-153 diversion boxes. The elevation of the drain inlets in the three diversion boxes range between 14-1/2 feet and 19 feet higher than the low point at the catch tank. The 241-C-252 diversion box is closest to the catch tank and located approximately 60 feet away. The elevation of the drain inlet in the 241-C-252 diversion box is approximately one foot higher (RPP-43427, *241-C Diversion Box Feasibility Study*). Operational controls will need to be implemented to prevent grout flow from traveling into the 241-C-252 diversion box during fill operations. Operational controls could include modifying the grout mix to reduce material flow or limiting the lift heights around the elevation where the drain lines enter the catch tank.

### **5.3 CLOSEOUT**

After the bulk tank fill operations are complete, any remaining in-tank equipment from the waste retrieval operation would be filled with grout or isolated. The passive breather filter would be removed and all remaining risers would be opened and filled with grout. Blind flanges would be installed on the risers at grade level following the final filling of the risers with grout.

## **6.0 COST AND SCHEUDLE**

Conceptual level cost and schedule estimates for waste retrieval and closure of the 241-C-301 catch tank were developed for deployment of two different waste retrieval systems, sluicing and vacuum retrieval systems. Cost and schedule estimates were developed based on adaptations of existing designs under current tank farm requirements for retrieval and transfer of tank waste. The schedule and cost estimates represent planning level estimates. No new or first of a kind technologies that require technology development and testing are utilized. Detail planning is contingent on definition of the requirements or criteria and the characteristics of the waste. The schedule shown for closure of 241-C-301 is linked to the completion of waste retrieval and is not integrated with other 241-C farm closure activities. It should be noted that the schedule developed is a nominal case and has not been optimized to perform activities in parallel or by modifying the schedule logic by starting activities in advance of finishing predecessor activities.

Cost and schedule estimates for the deployment of a sluicing waste retrieval system in the catch tank are provided in Appendix E. The estimated project cost for waste retrieval using sluicing followed by grout fill of the tank is approximately \$3.8M. The cost estimate is based on limited project definition and has an associated level of uncertainty. The schedule was developed by constraining the finish date for waste retrieval at December 31, 2013 and defining the necessary activities, schedule logic, and durations necessary for project execution. The December 31, 2013 completion date for waste retrieval operations was selected to enable transfer of the catch tank waste prior to completing the balance of the 241-C farm waste retrievals. The preliminary project schedule indicates that the catch tank retrieval and closure project should be initiated in October of 2011 in order to meet a December 31, 2013 waste retrieval completion date.

The cost and schedule estimates for the deployment of a vacuum retrieval system in 241-C-301 are provided in Appendix F. The estimated project cost for waste retrieval using a vacuum system similar to that deployed at the C-200 series tanks is approximately \$6.8M. The cost estimate is based on a number of enabling assumptions and has an inherent level of uncertainty. The cost estimate is based on procurement of a new non entry systems limited (NESL) vacuum retrieval system. There is an existing vacuum retrieval system currently in storage that could be deployed at 241-C-301. For the purposes of this study it is assumed that a new system would be procured and used either for the 241-C-301 deployment or to replace the system currently in storage. The schedule was developed by constraining the finish date for waste retrieval at December 31, 2013 and defining the necessary activities, schedule logic, and durations necessary for project execution. The December 31, 2013 completion date for waste retrieval operations was selected to enable transfer of 241-C-301 waste prior to completing the balance of the 241-C farm retrievals. The preliminary project schedule indicates that the 241-C-301 retrieval and closure project should be initiated in mid September of 2011 in order to meet a December 31, 2013 waste retrieval completion date.

## **7.0 RECOMMENDATIONS**

Defining the allowable residual waste volume in the catch tank upon the completion of the retrieval campaign is critical. There is no criterion currently established for the allowable

residual waste volume following the retrieval of a 300-series catch tank. The 300-series catch tanks have the same diameter as the 200-series tanks; however, they lack the inner steel shell, fully dished bottom design and have no readily available center access location similar to the majority of the 100-series tanks. The existing catch tank configuration limits the ability to retrieve down to a residual waste volume of less than 800 to 900 gallons if typical sluicing retrieval equipment is used.

The measurement, collection and analysis of both liquid and solid samples from catch tank 241-C-301 should be pursued as soon as possible. The radiological dose of the samples will directly impact the design of the retrieval system. Shielding, waste transfer and the method of retrieval rely on the collection of both radiological and physical properties of the waste. Early test results should be beneficial for the selection of the alternative retrieval methods. Additionally, the condition of the interior gunite layer should be inspected for potential cracking or other damage while the tank riser is opened to support the collection of samples.

Efforts should be given to accelerate the retrieval of the waste from the catch tank to coincide with the retrieval of waste from one of the 100-series tanks in the 241-C tank farm. The consent decree milestone date for the retrieval of waste from the 241-C tank farm SSTs is currently 2014. The 241-C-301 waste retrieval schedules in this study indicate that the project should be initiated no later than October 2011 to support transfer to a C-100 series tank. In the event the waste from 241-C-301 could be pumped directly to the closest SST (241-C-112) or another nearby tank while the SST is being retrieved, a considerable amount of retrieval infrastructure (HIHTL) installed for the 100-series tanks could be used. The contents of the catch tank could be transferred to the DST system, via the SST retrieval system. Selection of a 100-series tank for use as a temporary receiver tank is not dependent on the type of waste retrieval system deployed in the 100-series SST. Accelerating the existing retrieval of catch tank 241-C-301 would benefit from the use of currently trained operators and established retrieval system personnel.

The recommended approach for retrieving the 241-C-301 waste is to sluice the tank using raw water and transfer the waste to a 100-series tank in the 241-C farm. In the event that the residual waste inventory criteria is the same as the 200-series tanks (30 cubic feet) then a vacuum retrieval using an articulating mast may be necessary due to the configuration of the tank with the peripheral risers located above the lower knuckle region of the tank. Analysis of the solids sample will provide some insight as to how well sluicing would suspend the solids for removal.

Based upon retrieval system operating experience, cost considerations, and performance to date the preferred option is to sluice with raw water to the limits of technology, as limited by the pump placement above the lower knuckle region of the tank. Then perform a final rinse and saturation of the heel material with the single sluicer to dilute the remaining chemical and radiological inventory and transferring the resultant pumpable liquid. Continue portable exhaustor operations to evaporate the remaining liquid inventory from the catch tank to meet the residual waste criteria.

Additionally, considerable cost and schedule savings could be realized if the catch tank waste is transported within the 241-C tank farm to a 100-series tank actively being retrieved to the DST system. The 100-series waste retrieval system and supporting infrastructure can be utilized to the fullest extent prior to the expiration of HIHTL service life. Some equipment and materials

necessary to support the sluicing of the catch tank could likely be pulled from spare materials and used to support modified sluicing operations at the 241-C tank farm.

## 8.0 REFERENCES

Blue Print File 74650, *4 Catch Tanks BLDG #241 Hanford Engineering Works*, 1944, E4W-1G Sheet 2, National Guniting Contracting Co., DuPont Project.

Ecology, EPA, and DOE, 1989, *Hanford Federal Facility Agreement and Consent Order*, as amended, State of Washington Department of Ecology, U.S. Environmental Protection Agency, and U.S. Department of Energy, Olympia, Washington.

ECN 640456, *Vapor Sampling*, U.S. Department of Energy, 1997, Richland, Washington.

HNF-EP-0182, *Waste Tank Summary Report for Month Ending November 30, 2003*, Revision 188, Washington River Protection Solutions LLC, Richland, Washington.

HNF-EP-0182, *Waste Tank Summary Report for Month Ending April 30, 2010*, Revision 265, Washington River Protection Solutions LLC, Richland, Washington.

HNF-SD-WM-DP-291, *Waste Compatibility Safety Issues and Final Results for Tank U-301-B Grab Samples*, 1998, Revision 0, Waste Management of Hanford Inc., Richland, Washington.

H-2-1762, *Tank 241-C-301 Riser & Nozzle Elevs.*, 1949, Revision 1, Sheet 1, General Electric Hanford Works, Richland, Washington.

H-2-44502, *Flow Diagram Waste Transfer and Storage Facilities*, 1973, Revision 6, Sheet 8, U.S. Atomic Energy Commission, Richland, Washington.

H-2-85267, *Single Heated Vapor Tube Assembly*, 1994, Revision 0, Sheet 1, U.S. Department of Energy, Richland, Washington.

ORP-11242, *River Protection Project System Plan – Retrieve and Treat Hanford's Tank Waste and Close the Tank Farms to Protect the Columbia River*, 2009, Revision 4, Office of River Protection, U.S. Department of Energy, Richland, Washington.

RPP-16903, *Dome Load Capacity for 301 Catch Tanks 241-B, C, T and U*, 2004, Revision 2, CH2M HILL Hanford Group, Richland, Washington.

RPP-23403, *Single-Shell Tank Component Closure Data Quality Objectives*, 2009, Revision 4, Washington River Protection Solutions LLC, Richland, Washington.

RPP-29413, *Tank 241-C-200 Vacuum Retrieval Lessons Learned: Opportunities for Refinement of Future Retrieval Operations*, 2007, Revision 2, CH2M HILL Hanford Group, Richland, Washington.

RPP-RPT-43427, *241-C Diversion Box Feasibility Study*, 2010, Revision 0, Washington River Protection Solutions LLC, Richland, Washington.

- RPP-PLAN-23680, *Sampling and Analysis Plan for Residual Waste Solids in the C-200 Series Tanks*, 2005, Revision 0, CH2M HILL Hanford Group, Richland, Washington.
- RPP-PLAN-41977, *Single-Shell Tank System Component Identification and Proposed Closure Strategy*, 2009, Revision 0, Washington River Protection Solutions LLC, Richland, Washington.
- RPP-RPT-26475, *Retrieval Data Report for Single-Shell Tank 241-C-203*, 2008, Revision 1-A, CH2M HILL Hanford Group, Richland, Washington.
- RPP-RPT-29095, *Retrieval Data Report for Single-Shell Tank 241-C-202*, 2006, Revision 0, CH2M HILL Hanford Group, Richland, Washington.
- RPP-RPT-29484, *Options for Responding to the Assumed Leak from Catch Tank 241-ER-311*, 2006, Revision 0, CH2M HILL Hanford Group, Richland, Washington.
- RPP-RPT-30181, *Retrieval Data Report for Single-Shell Tank 241-C-201*, 2006, Revision 0-B, CH2M HILL Hanford Group, Richland, Washington.
- RPP-RPT-31779, *241-UX-302A Catch Tank Liquid Mitigation Completion Report*, 2006, Revision 0, CH2M HILL Hanford Group, Richland, Washington.
- RPP-RPT-33060, *Retrieval Data Report for Single-Shell Tank 241-C-103*, 2007, Revision 0, CH2M HILL Hanford Group, Richland, Washington.
- RPP-RPT-34062, *Retrieval Data Report for Single-Shell Tank 241-C-204*, 2007, Revision 0, CH2M HILL Hanford Group, Richland, Washington.
- RPP-RPT-41550, *Closure Demonstration Grout Test Report*, 2009, Revision 0, Washington River Protection Solutions, LLC, Richland, Washington.
- RPP-RPT-42231, *Summary of Twenty-Five Miscellaneous Tanks Associated with the Single-Shell Tank System*, 2009, Revision 0, Washington River Protection Solutions LLC, Richland, Washington.
- RPP-RPT-42789, *Completion of Removal of Pumpable Liquid from 241-UX-302A*, 2009, Revision 0, Washington River Protection Solutions, LLC, Richland, Washington.
- RPP-RPT-44139, *Hard Heel Waste Retrieval Technology Review and Roadmap*, 2010, Revision 0, Washington River Protection Solutions, LLC, Richland, Washington.
- RPP-RPT-47539, *MARS Eductor Phase 1 Verification Test Report*, 2010, Revision 0, Washington River Protection Solutions, LLC, Richland, Washington.
- WHC-SD-EN-ES-040, *Engineering Study of 50 Miscellaneous Inactive Underground Radioactive Waste Tanks Located at the Hanford Site Washington*, 1994, Revision 0, Westinghouse Hanford Company, Richland, Washington.
- WHC-SD-WM-RPT-198, *Vapor and Gas Sampling of Single-Shell Tank 241-C-301 Using the Vapor Sampling System*, 1996, Revision 0, Westinghouse Hanford Company, Richland, Washington.
- WHC-SD-WM-TI-356, *Waste Storage Tank Status and Leak Detection Criteria*, 1988, Revision 0, Westinghouse Hanford Company, Richland, Washington.

**APPENDIX A**

**CATCH TANK 241-C-301 LIQUID LEVELS AND ACTIVITIES 1974 TO 1985  
(WHC-SD-WM-TI-356)**

TANK C-301-C  
Liquid Level.

Date	Liquid level (in.)	Change from previous reading (in.)	Cumulative change (in.)	Comments
07/22/74	79.00			Manual tape
07/30/74	79.25	+0.25	+0.25	Slow increase
09/12/74	79.25		+0.25	Stable
09/19/74	81.75		+0.25	Diversion box work
11/27/74	81.75		+0.25	Stable
12/05/74	84.00		+0.25	Box work
01/14/75	86.00	+2.00	+2.25	Steady increase
01/26/75	97.00		+2.25	Box work
01/28/75	99.50	+2.50	+4.75	Unexplained rise
02/09/75	100.00	+0.50	+5.25	Slow increase
03/18/75	25.25		+5.25	Rain, box work, transfer
04/24/75	25.50	+0.25	+5.50	Slow increase
04/25/75	26.00		+5.50	Rain
05/02/75	26.00		+5.50	Stable
05/30/75	36.00		+5.50	Box work and rain
08/23/75	36.00		+5.50	Stable
08/28/75	36.75		+5.50	Rain
10/20/75	36.75		+5.50	Stable
10/26/75	37.50		+5.50	Rain
11/09/75	37.50		+5.50	Stable
11/11/75	38.00		+5.50	Rain
11/23/75	38.00		+5.50	Stable
01/22/76	48.75		+5.50	Rain, snow, and box work
02/27/76	49.25	+0.50	+6.00	Slow increase
02/28/76	49.75		+6.00	Box work
03/30/76	50.25	+0.50	+6.50	Slow increase
03/31/76	50.50		+6.50	Rain
04/25/76	51.25	+0.75	+7.25	Slow increase
08/28/76	51.25		+7.25	Stable
09/08/76	54.25		+7.25	Box work
11/04/76	54.50	+0.25	+7.50	Slow increase
11/08/76	56.25		+7.50	Box work
02/18/76	56.25		+7.50	Stable
03/23/77	66.50		+7.50	Box work and rain
04/20/77	66.50		+7.50	Stable
05/06/77	70.50		+7.50	Rain and box work
06/13/77	71.00	+0.50	+8.00	Slow increase
06/14/77	71.50		+8.00	Rain
08/02/77	71.75	+0.25	+8.25	Slow increase
08/04/77	76.00		+8.25	Line test
08/25/77	76.00		+8.25	Stable
08/31/77	77.75		+8.25	Rains
09/13/77	78.00	0.25	+8.50	Slow increase
09/29/77	79.00		+8.50	Box work and rain



TANK C-301-C  
Liquid Level.

Date	Liquid level (in.)	Baseline ref.	Change from previous reading (in.)	Cumulative change (in.)	Comments
10/17/77	79.25		+0.25	+8.75	Slow increase
10/23/77	18.75			+8.75	Box work and transfer
11/25/77	19.00		+0.25	+9.00	Slow increase
12/16/77	24.50			+9.00	Rains
01/05/78	25.25		+0.75	+9.75	Slow increase
02/09/78	41.50			+9.75	Rains and snows
02/25/78	42.50		+1.00	+10.75	Steady increase
03/30/78	44.50			+10.75	Box work and rains
05/02/78		45.00		+10.75	Rain
05/09/78		45.75		+10.75	Box work
05/15/78	45.75			+10.75	Stable
06/02/78		46.25	+0.50	+11.25	Slow increase
06/04/78	47.00			+11.25	Box work
06/28/78	47.50		+0.50	+11.75	Slow increase
08/28/78	48.75	48.75		+11.75	Rain
12/01/78	48.75			+11.75	Stable
12/13/78	49.25	49.25		+11.75	Rain
02/05/79	49.25			+11.75	Stable
02/13/79		51.25		+11.75	Snow melt
06/25/79		53.25		+11.75	Rain
10/26/79	53.50			+11.75	Stable
03/06/80		67.25		+11.75	Rain
06/30/80		73.25		+11.75	Rain drainage
09/16/80	73.25			+11.75	Stable
03/09/81		83.50		+11.75	Crane work and rain
06/15/81		86.50		+11.75	Rain drainage
10/09/81	86.50			+11.75	Stable
05/25/82		92.00		+11.75	Rain drainage
03/14/83		107.75		+11.75	Rain and diversion box work
05/13/83		110.50		+11.75	Rain
03/01/84		115.50		+11.75	Rain
04/25/84		118.00		+11.75	Rain
05/11/84	118.00			+11.75	Stable
06/29/84		119.25		+11.75	Rain drainage (June)
07/27/84	119.25			+11.75	Stable
09/13/84		121.50		+11.75	Diversion box work (August and September)
11/12/84	121.50			+11.75	Stable

TANK C-301-C  
Liquid Level.

Date	Liquid level (in.)	Baseline ref.	Change from previous reading (in.)	Cumulative change (in.)	Comments
02/19/85		127.00		+11.75	Rain and snow melt since November
04/10/85	128.00			+11.75	Rain
04/15/85	128.00			+11.75	stable
06/03/85	53.50			+11.75	Pumped and Interim Stabilized
06/24/85	53.50				Stable
06/25/85					Manual tape removed

Discontinued  
Tank Isolated

**APPENDIX B**

**CATCH TANK 241-C-301 LIQUID SAMPLE DATA 1974  
(RPP-RPT-42231)**

AEC #4783

bcc: G Burton, Jr. (2), w/att.  
DG Harlow, w/att.  
CW Malody, w/att.  
GC Oberg, w/att.  
MF Rice, w/att.  
HP Shaw, w/att.  
RM Smithers, w/att.  
TE Sparks, w/att.  
GT Stocking, w/att.  
JH Warren, w/att.  
AT White, w/att.  
Central File, w/att.

October 15, 1974

U. S. Atomic Energy Commission  
Richland Operations Office  
Richland; Washington 99352

Attention: Mr. O. J. Elgert, Director  
Production and Waste Management  
Programs Division

Subject: WASTE TANK SURVEY  
Contract AT(45-1)-2130

- References: (1) Letter, June 10, 1974, G. Burton, Jr.,  
to F. R. Standerfer, same subject
- (2) Letter, June 19, 1974, O. J. Elgert  
to G. T. Stocking, same subject,  
(PWM:CDC)
- (3) Letter, September 27, 1974,  
G. Burton, Jr., to O. J. Elgert,  
same subject

Gentlemen:

The attached summary of results on the 241-B-301, 241-C-301,  
241-T-301, and 241-U-301 active catch tanks is submitted in  
response to your request in reference 2.

These active catch tanks receive waste from the 151, 152,  
and 153 diversion box drains which may be due to leaking  
jumpers, flush solutions, or, more frequently, rain water.  
One sample result therefore does not necessarily represent  
the solution that is normally in each catch tank. Samples  
of these solutions are not required on a routine basis as  
the solutions are known to be compatible with other wastes,  
and the volumes in these 20,000-gallon tanks are small in  
relation to the 500,000 to 750,000-gallon underground  
storage tanks into which the wastes are pumped.

Very truly yours,

*/s/ G. Burton, Jr.*

G. Burton, Jr.  
Manager - Production and Waste Management

RECEIVED

OCT 17 1974

CENTRAL FILE

GB:err.

AUTHOR: DG Harlow	<i>Att.</i> <i>DGH</i>	APPROVED BY: G Burton, Jr.
OPERATION	OTS	TIFM
FOR APPROVAL OF	GC Oberg	RM Smithers
APPROVED	<i>GC Oberg</i>	<i>RM Smithers</i>
DATE	<i>10/19/74</i>	<i>10/10/74</i>

ATTACHMENT

ANALYTICAL DATA FOR 241-B-C-T-U 301 TANKS

Tank	241-B-301	241-C-301	241-T-301	241-U-301
Sample Number	8409T	8410T	8497T	8498T
Visual	Pale yellow, no solids	Clear, yellow, no solids	Clear, yellow, no solids	Yellow, no solids
OTR, mR	25	130	50	10
pH	8.50	9.30	8.70	10.90
Tα, grams/gallon	4.77 x 10 <sup>-3</sup>	6.09 x 10 <sup>-2</sup>	3.07 x 10 <sup>-3</sup>	<8.44 x 10 <sup>-4</sup>
Fu, grams/gallon	<6.58 x 10 <sup>-7</sup>	<6.58 x 10 <sup>-7</sup>	<6.58 x 10 <sup>-7</sup>	<6.58 x 10 <sup>-7</sup>
U, pounds/gallon	1.77 x 10 <sup>-5</sup>	5.0 x 10 <sup>-4</sup>	6.08 x 10 <sup>-5</sup>	4.96 x 10 <sup>-5</sup>
Tβ, μCi/gallon	9.01 x 10 <sup>2</sup>	1.7 x 10 <sup>3</sup>	3.04 x 10 <sup>2</sup>	6.21 x 10 <sup>2</sup>
<sup>134</sup> Cs, μCi/gallon	88.64	1.47 x 10 <sup>2</sup>	13.47	98.98
<sup>137</sup> Cs, μCi/gallon	1.14 x 10 <sup>4</sup>	2.55 x 10 <sup>4</sup>	1.6 x 10 <sup>3</sup>	1.01 x 10 <sup>4</sup>
<sup>106</sup> Ru, μCi/gallon	-	-	5.94 x 10 <sup>3</sup>	-

RLM:jas  
10-10-74

**APPENDIX C**

**CATCH TANK 241-C-301 LIQUID SAMPLE DATA 1985  
(RPP-RPT-42231)**

RPP-RPT-4223, Rev. 0  
ANA-012/851/24  
EW/85C 301 C CATCH TANK  
SAMPLE # T 2179OH<sup>-</sup> TOO LOWNO<sub>2</sub><sup>-</sup>  $2.53 \times 10^{-2}$  MNO<sub>3</sub><sup>-</sup>  $2.44 \times 10^{-2}$  MTOTAL  $\alpha$   $3.23 \times 10^{-1}$   $\mu\text{Ci/l}$ GEA <sup>137</sup>Cs  $1.02 \times 10^{-4}$   $\mu\text{Ci/l}$ TOTAL  $\beta$   $1.73 \times 10^{-4}$   $\mu\text{Ci/l}$ 

PH 7.52

SAMPLE IS CLEAR, LT GREEN, NO SEPARABLE  
LAYER

40 MR/HR OVER THE TOP

R-05857

C 301 CATCH TANK

CALCULATE TOTAL HEAT GENERATION

SAMPLE T2179 (1-24-85)

GEA  $^{137}\text{Cs}$   $1.03 \times 10^4 \mu\text{Ci}/\text{L}^*$

TOTAL  $\beta$   $1.73 \times 10^4 \mu\text{Ci}/\text{L}$

\*  $^{60}\text{Co}$  AND  $^{229}\text{Ra}$  APPEARED IN NEG. AMOUNTS

ASSUME  $\beta$  IS  $^{90}\text{Sr}$

$^{137}\text{Cs}$   $^{137}\text{Ba}$   $1.61 \times 10^{-2} \text{ BTU}/\text{HR}/\text{Ci}$

$^{90}\text{Sr}$   $^{90}\text{Y}$   $2.29 \times 10^{-2} \text{ BTU}/\text{HR}/\text{Ci}$

TOTAL HEAT ( $\frac{\text{BTU}}{\text{HR}}$ ) =

$$\left[ \left[ (1.03 \times 10^4 \frac{\mu\text{Ci}}{\text{L}}) (1.61 \times 10^{-2} \frac{\text{BTU}}{\text{HR}\cdot\text{Ci}}) (\frac{\text{Ci}}{10^6 \mu\text{Ci}}) + \right. \right. \\ \left. \left[ (1.73 \times 10^4 \frac{\mu\text{Ci}}{\text{L}}) (2.29 \times 10^{-2} \frac{\text{BTU}}{\text{HR}\cdot\text{Ci}}) (\frac{\text{Ci}}{10^6 \mu\text{Ci}}) \right] \right] \times \\ \left[ (24,000 \text{ GAL}) (3.785 \frac{\text{L}}{\text{GAL}}) \right]$$

$$= 50 \text{ BTU}/\text{HR}$$

(TOTAL Ci CONTENT 550 Ci)

4-25-85  
CW



**APPENDIX D**

**STABILIZATION EVALUATION FORM FOR CATCH TANK 241-C-301  
(RPP-RPT-42231)**

STABILIZATION EVALUATION FORM

Tank: C-301

Evaluation (see continuation page for calculations and additional comments):

(X) Tank history review completed

(X) Tank composition data reviewed

Tank Description: CATCH TANK

Solids Level: 3'-10" Date: 5-21-85 Method: Pancake

Liquid Level: 4'-5 1/2" Date: 5-31-85 Method: Zip Cord

Estimated Supernatant Volume (gal): 1421 gal.

Interim Stabilization Criteria: 5000 gal  
(400 gallons or the volume of four inches of supernatant, whichever is greater or 5000 gallons as specified by para 3.1.1 of EPM 4.6, dated June 22, 1984.)

( ) Cost/Benefit Analysis attached

Evaluation performed by: Allen T. Alatal Date: 6-3-85

Checked by: Wojtaszek Date: 6-3-85

Disposition of Tank:

(X) Tank Interim Stabilized at 1421 gallons of supernatant liquid

( ) Tank not Interim Stabilized; stabilization activities resumed

Approved by: Ra Van Meter 6/3/85  
for Manager, TF&EPC Date

Wojtaszek 6/3/85  
Manager, TFS&D Date

R.D. Wojtaszek 6-3-85  
Program Manager Date

DISTRIBUTION: TF&EPC Tank File, Tank Farm Surveillance Analysis, Approval Signatures

REF: H-W-72182, Sheet 4

EVALUATION CALCULATIONS AND COMMENTS

Tank: 241-C-301

Tank Geometry:

TDP OF RISER TO BOTTOM OF TANK 3.1.13.

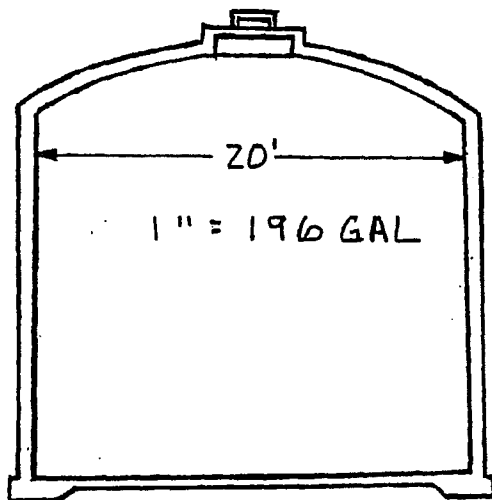

Calculations made by: Allen T. Albert

Checked by: Wesley W. Smith 6/5/85

**APPENDIX E**

**COST AND SCHEDULE ESTIMATES FOR DEPLOYMENT  
OF A SLUICING WASTE RETRIEVAL SYSTEM IN C-301**

RPP-RPT-45723, Rev. 0

C-301 Retrieval and Closure Costs - Sluicing				
		Schedule Duration (Days)	Cost	Notes/ Basis of Estimate
1	<b>C-301 Retrieval and Closure (Sluicing)</b>	694		
1.1	<b>Regulatory/Permitting</b>	603		
1.1.1	<b>Retrieval</b>	180		
	Identify Reg Reqmts	40	\$12,000	Based on dev. Regulatory approach and coordination w/Ecology - 120 hrs @ \$100/hr
	Waste Ret. Plan	80	\$40,000	Parallels a TWRWP - includes \$25K draft, \$15K comment resolution
	EPA Revise RBDA	30	\$0	EPA task, assume no project cost
	NOC	195	\$104,000	Based on the equivalent of 1FTE 6 months for prep of the NOC, 12 months for agency review, comment resolution, and approval
	NEPA Screening	15	\$7,500	Based on 75 hrs @ \$100/hr (40 hrs to review project data and prepare checklist plus 35 hrs for reviews and comment resolution)
1.1.2	<b>Closure</b>	563		
	Permit Mod	150	\$0	Assume this activity is covered at the program level
	Waste determination	150	\$0	Assume this activity is covered at the program level
	Confirm Retrieval Criteria Met (Ecology concurrence)	40	\$5,000	Prepare completion letter, coordinate, meet with regulators 50 hrs @ \$100/hr
1.2	<b>C-301 Sampling and Analysis</b>	513		
1.2.1	<b>Pre-ret core sample</b>	118		
	SAP	10	\$12,000	Eng. estimate for development of the sampling/analysis plan 120 hrs (80 draft + 40 review/approve) @ \$100/hr
	Work Package	20	\$15,000	Eng. estimate based on historical data
	Sampling	8	\$141,800	Based on crew of 2 supvs, 10 NCOs, 6 HPTs, 1 Safety for 8 days, 4 tmstrs & 1 shipper for 1 day. Total hours = 19 * 9 * 8 + 5 * 10 = 1,418 hrs. Cost 1,418 * \$100/hr = \$141800.
	Analysis and Reporting	80	\$280,000	Hours fm S Kooiker - sampling field supervisor on 5/19/10 Eng Est placeholder pending DQO specific estimate. Covers solid and liquid sample analysis and reporting of results
1.2.2	<b>Post ret residual sample</b>	95		
	SAP	0	\$0	Assume pre retrieval sample is sufficient and no post retrieval sample analysis required
	Work Package	0	\$0	Assume pre retrieval sample is sufficient and no post retrieval sample analysis required
	Collect Sample	0	\$0	Assume pre retrieval sample is sufficient and no post retrieval sample analysis required
	Analysis & Reporting	0	\$0	Assume pre retrieval sample is sufficient and no post retrieval sample analysis required
1.3	<b>C-301 Retrieval Design and Eng</b>	185		
	System Specification	25	\$20,000	Eng Estimate - subsystem spec
	60% Design	40	\$300,000	Eng Estimate - subsystem spec
	Safety Basis Amendment	80	\$20,000	NS&L eng 200 hrs @ \$100/hr
	Final Design	35	\$200,000	Eng Estimate
	General TF Engineering	120	\$216,000	Oversight of A&E plus general eng (PrHA, USQ, CGI documentation, finalize PCP, waste compatability, etc) equivalent to 2 FTEs
1.4	<b>C-301 Retrieval System Procurement</b>	115		
	Long Lead Items	100	\$300,000	Based on \$200K qualified slurry pump & HPU (MARS slurry pump and HPU \$230K); \$20K qualified PRV; \$80K pump deployment assy
	HIHTL to 241-C	80	\$200,000	Based on 400' of 2"x4" HIHTL @ \$500/ft. Assume heat trace & insulation and routed to another 241-C tank
	Procure Materials	40	\$150,000	ROM steel plate, fittings, leak detectors, vehicle barriers, control system, control trailer
	Fabricate Equipment	35	\$150,000	ROM Pump riser box at C-301 and riser adapter at receiver tank.
	LDM Hardware	60	\$90,000	Historical basis from previous LDM deployments for cables/testing.
1.5	<b>C-301 Retrieval System Testing</b>	55		
	Prepare Test Plan	20	\$12,000	80 hrs to prepare, 40 hrs review/approve = 120 hrs @ \$100/hr
	Procure test equipment	15	\$10,000	ROM misc test equipment and materials
	Test set up	5	\$50,000	crew of 10 for 5 days to assemble equipment and test set up. 10 x 5 x 10 hr/day x \$100/hr
	Perform testing	5	\$75,000	crew of 15 for 5 days to perform testing. 15 x 10 hrs/day x 5 days x \$100/hr
	Prepare test report	10	\$6,000	40 hrs to prepare, 20 hrs to review/approve
1.6	<b>C-301 Retrieval System Installation</b>	85		
	Install Ventilation System	40	\$70,000	Work package \$10K, crane crew 3 days @ \$10K/day, crew of 10 for 5 days @ \$50K assumes use of an existing exhaustor skid
	Install in-tank video	5	\$30,000	Work package \$10K, crew of 10 for 2 days @ 20K
	Install pump/ret system	30	\$200,000	Work package \$10K, crew of 10 for 5 days to stage, crew of 15 for 8 days to assemble equip, install hose, make connections; crane for 2 days @ \$10K/day
	LDM System Installation	20	\$20,000	crew of 10 for 2 days
	Perform Const Acceptance Testing	25	\$70,000	Work package \$20K, crew of 10 for 5 days @ \$50K
1.7	<b>C-301 Retrieval System Operation</b>	180		
	Readiness review, checklist	10	\$30,000	readiness - \$20K; training and drills crew of 10 for 1 day @ \$10K
	Operate waste retrieval system (sluicing)	30	\$300,000	crew of 10 for 30 days @ 10 hrs/day @ \$100/hr
	Extended Exhauster Operation	120	\$54,000	assume 2 operators at 1/4 time to monitor exhauster operation
	Confirm residual vol & limit of retrieval	15	\$4,000	video estimate of residual volume 40 hours to evaluate and review
	C-301 Leak Detection and Monitoring Operation	60	\$75,000	based on historical data for LDM subcontract assumes another C farm tank is also being monitored. 3 months at \$25K/month.
	Complete C-301 Waste Retrieval Operations	0		
1.8	<b>C-301 Closure Design</b>	90		
	System Specification	30	\$15,000	Prepare, review, and issue system spec for closure design
	Design and Engineering	60	\$60,000	300 hrs @ 100 \$/hr for const spec, 2 ECNs, developing sequence and grout delivery connections plus oversight and coordination 300 hrs @ \$100/hr.
1.9	<b>C-301 Closure Operation</b>	127		
1.9.1	<b>Work Package</b>	20	\$30,000	4 work packages total (remove pump, place grout, reconfigure ventilation system)
1.9.2	<b>Remove in-tank retrieval equipment</b>	20	\$220,000	crew of 10 for 10 days to disconnect equipment and cleanup @ \$100K; crane for 2 days @ 20K; disposal \$100K
1.9.3	<b>Readiness Checklist</b>	5	\$5,000	
1.9.4	<b>Closure Grout Fill Operations</b>	82		
1.9.4.1	<b>Contracting</b>	60	\$8,000	prepare SOW, review proposals, award contract 80 hrs
1.9.4.2	<b>Mobilize</b>	5	\$15,000	crew of 5 for 3 days
1.9.4.3	<b>Set up equipment</b>	2	\$20,000	crew of 10 for 2 days
1.9.4.4	<b>Place stabilization grout (3 trucks)</b>	3	\$17,600	crew of 10 for 1 day @ 10K, equipment rental @ \$4K; material 30 yards grout @ 120/yard
1.9.4.5	<b>Place bulk fill grout (15 trucks)</b>	10	\$78,000	crew of 10 for 5 days @ 50K, equipment rental \$10K; material 150 yards grout @ 120/yard
1.9.4.6	<b>Grout risers (1 truck)</b>	2	\$25,200	crew of 10 for 2 days @ 20K, equipment rental \$4K; material 10 yards grout @ 120/yard
1.9.4.7	<b>Complete C-301 Stabilization (Tank Closure)</b>	0		
	<b>Subtotal</b>		<b>\$3,763,100</b>	
	<b>Contingency</b>		<b>\$0</b>	
	<b>Total</b>		<b>\$3,763,100</b>	

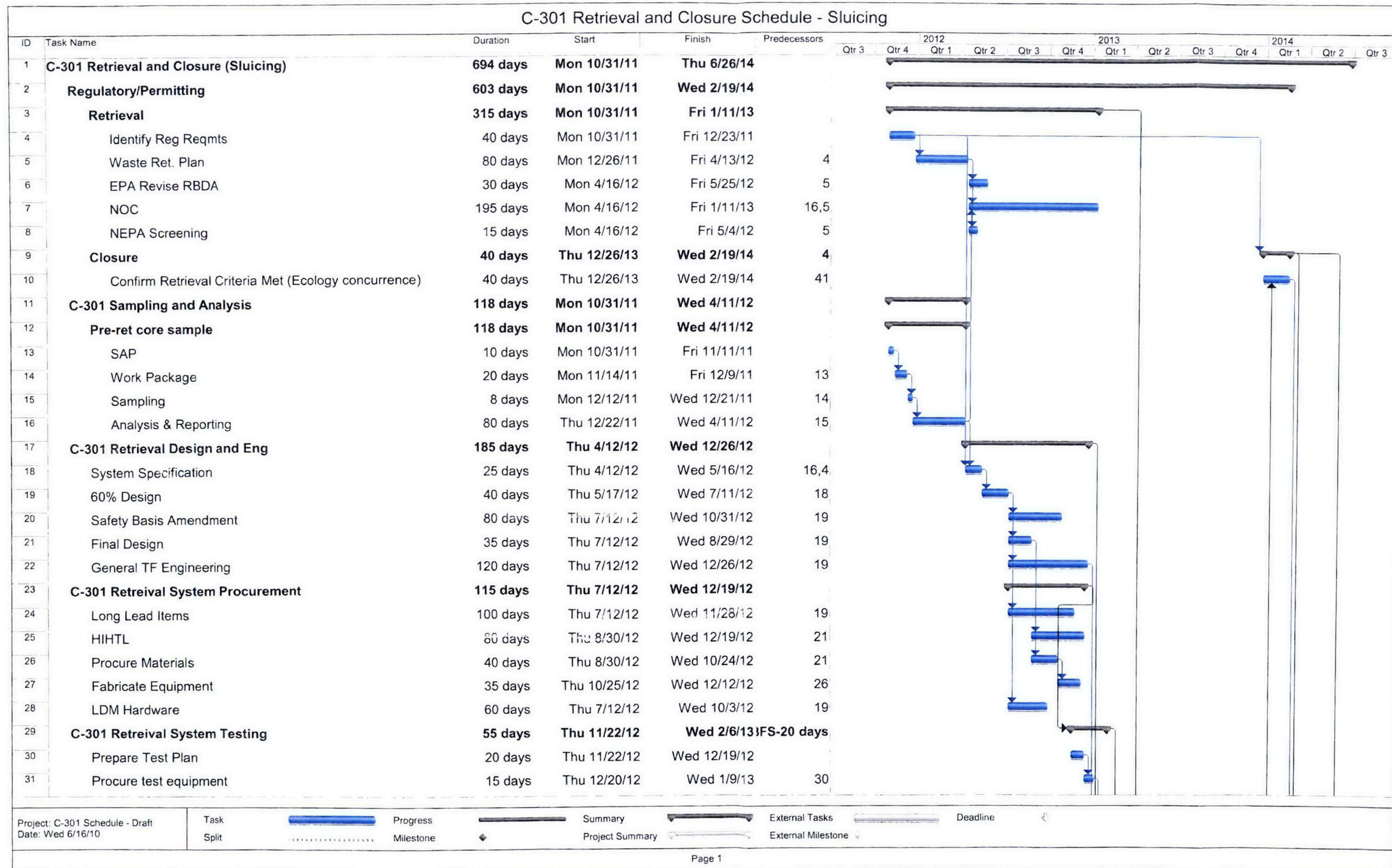



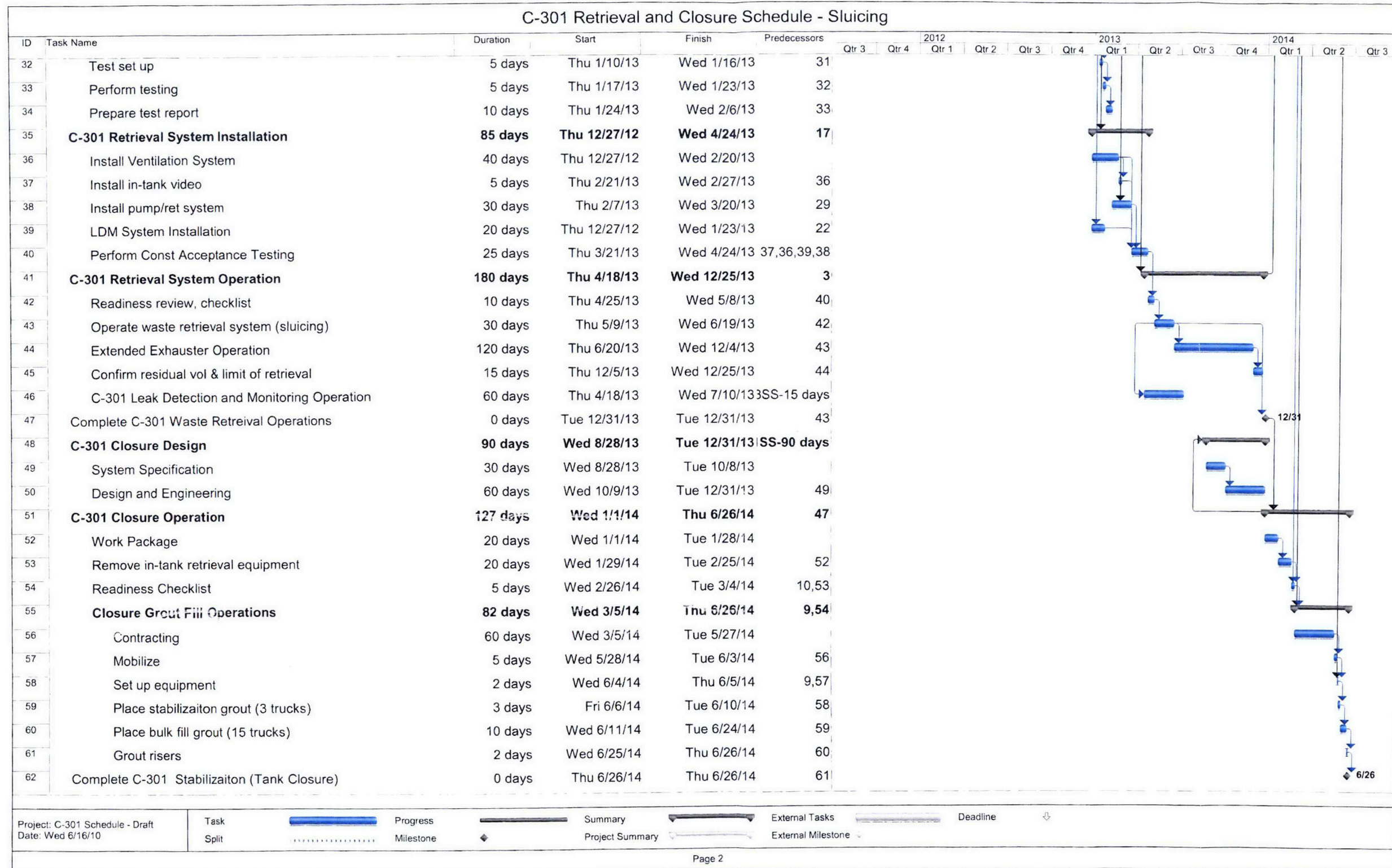

**APPENDIX F**

**COST AND SCHEDULE ESTIMATES FOR DEPLOYMENT  
OF A VACUUM RETRIEVAL SYSTEM IN C-301**



RPP-RPT-45723, Rev. 0

Cost Estimate for Deployment of a Vacuum Retrieval System in C-301				
		Schedule Duration (Days)	Cost	Notes/ Basis of Estimate
1	<b>C-301 Retrieval and Closure (Sluicing)</b>	694		
1.1	<b>Regulatory/Permitting</b>	603		
1.1.1	Retrieval	180		
	Identify Reg Reqmts	40	\$12,000	Based on dev. Regulatory approach and coordination w/Ecology - 120 hrs @ \$100/hr
	Waste Ret. Plan	80	\$40,000	Parallels a TWRWP - includes \$25K draft, \$15K comment resolution
	EPA Revise RBDA	30	\$0	EPA task, assume no project cost
	NOC	195	\$104,000	Based on the equivalent of 1FTE 6 months for prep of the NOC, 12 months for agency review comment resolution, and approval
	NEPA Screening	15	\$7,500	Based on 75 hrs @ \$100/hr ( 40 hrs to review project data and prepare checklist plus 35 hrs for review and comment resolution)
1.1.2	Closure	563		
	Permit Mod	150	\$0	Assume this activity is covered at the program level
	Waste determination	150	\$0	Assume this activity is covered at the program level
	Confirm Retrieval Criteria Met (Ecology concurrence)	40	\$5,000	Prepare completion letter, coordinate, meet with regulators 50 hrs @ \$100/hr
1.2	<b>C-301 Sampling and Analysis</b>	513		
1.2.1	<b>Pre-ret core sample</b>	118		
	SAP	10	\$12,000	Eng. estimate for development of the sampling/analysis plan 120 hrs (80 draft + 40 review/approve) @ \$100/hr
	Work Package	20	\$15,000	Eng. estimate based on historical data
	Sampling	8	\$141,800	Based on crew of 2 supvs, 10 NCOs, 6 HPTs, 1 Safety for 8 days, 4 tmstrs and 1 shipper for 1 day. Total hours = 19 * 9 * 8 + 5 * 10 = 1,418 hrs. Cost 1,418 * \$100/hr = \$141,800.
	Analysis & Reporting	80	\$280,000	Hours fr S Kooiker - sampling field supervisor on 5/19/10
1.2.2	<b>Post ret residual sample</b>	95		Eng Est placeholder pending DQO specific estimate. Covers solid and liquid sample analysis and reporting of results
	SAP	0	\$0	Assume pre retrieval sample is sufficient and no post retrieval sample analysis required
	Work Package	0	\$0	Assume pre retrieval sample is sufficient and no post retrieval sample analysis required
	Collect Sample	0	\$0	Assume pre retrieval sample is sufficient and no post retrieval sample analysis required
	Analysis & Reporting	0	\$0	Assume pre retrieval sample is sufficient and no post retrieval sample analysis required
1.3	<b>C-301 Retrieval Design and Eng</b>	205		
	System Specification	25	\$20,000	Eng Estimate - subsystem spec
	60% Design	60	\$500,000	Eng Estimate
	Safety Basis Amendment	80	\$40,000	NS&L eng 400 hrs @ \$100/hr
	Final Design	45	\$250,000	Eng Estimate
	General TF Engineering	120	\$216,000	Oversight of A&E plus general eng (PrHA, USQ, CGI documentation, finalize PCP, waste compatability, etc) equivalent to 2 FTEs for 120 days @ 9 hrs/day @ \$100/hr.
1.4	<b>C-301 Retrieval System Procurement</b>	115		
	Long Lead Items	100	\$2,042,450	based on estimate provided by Dave Smet for a complete next generation vacuum retrieval system.
	HIHTL to 241-C location	80	\$250,000	Based on 500' of 2"x4" HIHTL @ \$500/ft. Assume heat trace & insulation and routed to a 241-C location
	Procure Materials	40	\$150,000	Increase over sluicing to provide for lines from tank to skids and between skids
	Fabricate Equipment	35	\$100,000	ROM steel plate, fittings, leak detectors, vehicle barriers, controls, control trailer
	LDM Hardware	60	\$0	ROM riser adapter at receiver tank.
1.5	<b>C-301 Retrieval System Testing</b>	55		assume no LDM for deployment of the vacuum retrieval system
	Prepare Test Plan	20	\$12,000	80 hrs to prepare, 40 hrs review/approve = 120 hrs @ \$100/hr
	Procure test equipment	15	\$10,000	ROM misc test equipment and materials
	Test set up	5	\$50,000	crew of 10 for 5 days to assemble equipment and test set up. 10 x 5 x 10 hr/day x \$100/hr
	Perform testing	30	\$450,000	crew of 15 for 5 days to perform testing. 15 x 10 hrs/day x 5 days x \$100/hr
	Prepare test report	10	\$5,000	40 hrs to prepare, 20 hrs to review/approve
1.6	<b>C-301 Retrieval System Installation</b>	85		
	Install Ventilation System	40	\$70,000	Work package \$10K, crane crew 3 days @ \$10K/day, crew of 10 for 5 days @ \$50K
	Install in-tank video	5	\$30,000	Work package \$10K, crew of 10 for 2 days @ 20K
	Install vacuum ret system skids	30	\$250,000	Work package \$10K, crew of 10 for 5 days to stage, crew of 15 for 10 days to assemble equip, install hose
	LDM System Installation	20	\$20,000	make connections; crane for 4 days @ \$10K/day
	Perform Const Acceptance Testing	25	\$70,000	crew of 10 for 2 days
				Work package \$20K, crew of 10 for 5 days @ \$50K
1.7	<b>C-301 Retrieval System Operation</b>	180		
	Readiness review, checklist	10	\$30,000	readiness - \$20K; training and drills crew of 10 for 1 day @ \$10K
	Operate waste retrieval system (vacuum)	120	\$1,200,000	crew of 10 for 120 days @ 10 hrs/day @ \$100/hr
	Extended Exhauster Operation		\$0	no extended exhauster operation
	Confirm residual vol and limit of retrieval	15	\$4,000	video estimate of residual volume 40 hours to evaluate and review
	C-301 Leak Detection and Monitoring Operation	60	\$0	assume no LDM for deployment of the vacuum retrieval system
	Complete C-301 Waste Retrieval Operations	0		
1.8	<b>C-301 Closure Design</b>	90		
	System Specification	30	\$15,000	Prepare, review, and issue system spec for closure design
	Design and Engineering	60	60,000	300 hrs @ 100 \$/hr for const spec, 2 ECNs, developing sequence and grout delivery connections plus oversight and coordination 300 hrs @ \$100/hr.
1.9	<b>C-301 Closure Operation</b>	127		
1.9.1	Work Package	20	\$30,000	4 work packages total (remove pump, place grout, reconfigure ventilation system)
1.9.2	Remove in-tank retrieval equipment	20	\$170,000	crew of 10 for 5 days to disconnect equipment and cleanup @ \$50K; crane for 2 days @ 20K; disposal \$100K
1.9.3	Readiness Checklist	5	\$5,000	
1.9.4	<b>Closure Grout Fill Operations</b>	82		
1.9.4.1	Contracting	60	\$8,000	prepare SOW, review proposals, award contract 80 hrs
1.9.4.2	Mobilize	5	\$15,000	crew of 5 for 3 days
1.9.4.3	Set up equipment	2	\$20,000	crew of 10 for 2 days
1.9.4.4	Place stabilization grout (3 trucks)	3	17,600	crew of 10 for 1 day @ 10K, equipment rental @ \$4K; material 30 yards grout @ 120/yarc
1.9.4.5	Place bulk fill grout (15 trucks)	10	78,000	crew of 10 for 5 days @ 50K, equipment rental \$10K; material 150 yards grout @ 120/yarc
1.9.4.6	Grout risers	2	25,200	crew of 10 for 2 days @ 20K, equipment rental \$4K; material 10 yards grout @ 120/yarc
1.9.4.7	Complete C-301 Stabilization (Tank Closure)	0		
	<b>Subtotal</b>		<b>\$6,831,550</b>	
	<b>Contingency</b>		<b>\$0</b>	
	<b>Total</b>		<b>\$0</b>	

