

The author(s) shown below used Federal funds provided by the U.S. Department of Justice and prepared the following final report:

Document Title: Knife and Saw Toolmark Analysis in Bone: A Manual Designed for the Examination of Criminal Mutilation and Dismemberment

Author: Steven A. Symes, Ph.D., Erin N. Chapman, M.S., Christopher W. Rainwater, M.S., Luis L. Cabo, M.S., and Susan M.T. Myster, Ph.D.

Document No.: 232227

Date Received: October 2010

Award Number: 2005-IJ-CX-K016

This report has not been published by the U.S. Department of Justice. To provide better customer service, NCJRS has made this Federally-funded grant final report available electronically in addition to traditional paper copies.

Opinions or points of view expressed are those of the author(s) and do not necessarily reflect the official position or policies of the U.S. Department of Justice.

National Institute of Justice

Contract Number #2005-IJ-CX-K016

Project Title: "Knife and Saw Toolmark Analysis in Bone: A Manual Designed for the Examination of Criminal Mutilation and Dismemberment"

PI: Steven A. Symes, PhD
Mercyhurst Archaeological Institute
Mercyhurst College
501 E. 38th St.
Erie, PA 16546
Phone: (814) 824-3369
Fax: (814) 824-3627
Email: ssymes@mercyhurst.edu

co-PIs: Erin N. Chapman, MS
Mercyhurst College
Erie, PA

Christopher W. Rainwater, MS
Office of Chief Medical Examiner/New York University
New York, NY

Luis L. Cabo, MS
Mercyhurst College
Erie, PA

Susan M.T. Myster, PhD
Hamline University
St. Paul, MN

Administrative POC:

Anna Varhola
Address: Same as above
Phone: (814) 824-2531
Fax: (814) 824-2594
Email: avarhola@mercyhurst.edu

Financial POC:

Ed Hess
Address: Same as above
Phone: (814) 824-2252
Fax: (814) 824-2594
Email: ehess@mercyhurst.edu

Abstract

Marks left on human remains when serrated tools cut through hard tissues (bone and cartilage) allow assessing the class characteristics of the inflicting tool. This is of particular importance in cases of dismemberment, or when the inflicting weapon is a serrated knife.

In spite of this forensic relevance, the analysis of saw marks in bone has traditionally suffered from three interrelated major problems: (1) a lack of research, (2) a related lack of standard terminology, definitions and protocols for the documentation and analysis of this evidence, and (3) as a consequence, a poor understanding and awareness among the forensic community regarding the evidentiary value and possibilities of this type of physical evidence.

The combination of these three factors has promoted the appearance and promotion of multiple misconceptions on the issue, partly derived from the frequent need to improvise analytical protocols and solutions, when forensic anthropologists and pathologists are asked to analyze and testify on saw mark evidence.

This project addresses these problems through the development and presentation of standard definitions, documentation protocols and analytical methodologies to enable more accurate and reliable analyses of saw marks in bone and other hard tissues. These contributions are primarily presented within a brief, user-friendly manual, intended to serve as a primer for the introduction of saw mark analysis to a wide array of forensic professionals, and serving as a first key step to normalize analytical and documentation protocols for this type of evidence.

For the production of these instructional materials, the project relied first on the creation, analysis and documentation of a comparative sample of human remains cut with different serrated tools covering a spectrum of the main commercial saw types and classes. This sample was produced following a double randomization design (the sequences of both the bone fragments and the different tools used to cut through them were randomized.) In this manner, this resource can also serve as a baseline comparative sample for an array of future studies and experimental designs on saw mark analysis.

The design and evaluation of the instructional materials also relied on an active dissemination strategy, through a series of lectures (around 50 during the duration of the project) delivered by the authors to a variety of forensic professionals, including forensic anthropologists, pathologists general tool mark analysts, among others. This served a twofold objective: first for the direct dissemination of the projects and its results and, secondly, to test the efficacy and appropriateness of the different instructional materials being developed.

Further testing of the manual, as well as of the reliability of different proposed markers for the analysis of basic tool parameters (class characteristics), was performed through inter- and intra-observer studies, controlling for the degree of experience and exposure of the participants to the produced instructional materials.

The experimental component of the project also examined some common misconceptions on the evidentiary value of some major saw mark elements, particularly the macroscopic striations that usually provide the initial clue to identify a particular defect as produced by a serrated object. This battery of analyses also served to assess

the effectiveness and analytical possibilities offered by metric and non-metric approaches, propose and demonstrate different general experimental designs for further research on the subject, and demonstrate the relative importance of physical factors, independent of the inflicting tool, in determining saw mark morphology.

The authors expect that the groundwork provided by the provided manual and analytical examples will help to further increase not only the awareness on the importance of saw mark analysis on bone, but the communication and cooperation of analysts from diverse fields in future research and criminal investigations.

TABLE OF CONTENTS

PART I: EXECUTIVE SUMMARY.....	1
Description of Problem.....	1
Purpose, Goals and Objectives.....	2
Research Design.....	4
Findings and Conclusions.....	12
PART II: PROJECT DESCRIPTION.....	17
Materials and Methods.....	17
Sample.....	17
Processing and Preparation.....	17
Description of Saw Sample.....	19
Sample Randomization.....	19
Cutting Methodology	19
Description of Analysis Sample.....	21
Metric versus Visual Assessment of Saw Power.....	22
Phase 1- Part A: Pilot Study.....	24
Phase 1- Part B: Geometric Model.....	27
Phase 2: Inter-observer Error Study.....	33
Phase 2- Part A.....	33
Phase 2- Part B.....	35
Phase 2 Analyses.....	37
Results from Phase 1.....	37
Results from Phase 2.....	41
Discussion.....	48
Phase 1: Metric Analyses.....	48
Phase 2: Visual Assessment.....	48
Frequency of Traits and Characteristics.....	49
Introduction.....	49
Sample.....	49
Trait Coding.....	50
Results.....	50

PART III: PRODUCTS OF NIJ FUNDING.....54

NIJ Research Milestones.....54

Sawmark Analysis Website.....58

Comparative Collection and Database.....58

Sawmark Analysis Manual.....61

- Introduction and Background.....61
- History of Sawmark Analysis.....61
- Current Status of Toolmark Analysis.....64
- Misconceptions Regarding Trauma Analysis.....65
- Diagnostic Features of a Saw.....72
- Principles of Cutting Action.....78
 - Blade and Tooth Size.....78
 - Blade and Tooth Set.....79
 - Blade and Tooth Shape.....84
 - Saw Power.....89
 - Direction of Saw Motion.....91
- Introduction to Sawmark Analysis.....95
 - Traits and Characteristics: Size, Set, Shape.....95
 - Traits and Characteristics: Saw Power.....101
 - Traits and Characteristics: Saw Direction.....102
 - Exemplar Sawmark Data Collection Sheet.....104
 - Exemplar Sawmark Diagnostic Sheet.....106
 - Guide to Data Sawmark Data Collection.....107

REFERENCES.....112

APPENDICIES.....116

Part II: Project Description.....116

- Appendix II-A: Bone Sample Measurements.....116
- Appendix II-B: Saw Sample Information.....118
- Appendix II-C: Randomized Cutting Sequence.....121
- Appendix II-D: Traits and Coding.....123

Part III: Products of NIJ Funding.....124

- Appendix III-A: AFTE Handout.....124

PART I: EXECUTIVE SUMMARY

Description of the Problem

Saws are common tools in criminal cases where body dismemberment is employed as a means to conceal, displace and alter the evidence. When cutting through bone or cartilaginous tissue, the tools used for this purpose leave distinct marks that can reveal key class characteristics of the inflicting weapon. The same is true for serrated knives used as dismemberment weapons. While these cases are relatively unusual (although no statistics on the relative frequencies of dismemberments or serrated knife cases have been systematically compiled), the initial assessment of the offending tool and the eventual expert testimony often have a significant impact on the criminal trials related to these cases.

As a consequence, after the evidentiary value and investigative potential of saw marks were firmly established (largely through the early research and continued casework of the PI), the forensic community has grown increasingly aware of its relevance in the past few decades. Currently, different forensic specialists (notably anthropologists and pathologists) are asked to conduct occasional saw and knife mark analyses and testify on their results.

In spite of this state of matters, little attention has been paid to this field in terms of research. This is largely related to two closely intertwined factors: (1) A still incomplete awareness among pathologists, law enforcement and tool-mark analysts on the progress made by forensic anthropologists on this subject; and, (2) a lack of basic standard terminology and protocols for the analysis of saw marks on bone and cartilage.

There is some circularity in the relationship between the deficiency in awareness and research. The former can be explained by a certain lack of overlap between the anthropological and the medical literature, but this gap will be further magnified when the volume of research on the subject is scarce: the less frequent the publications on the subject, the higher the chance of them passing unnoticed by other professionals. As a result, the forensic practitioner confronted with saw marks on hard tissues is most frequently left with little bibliographical support, often being forced to reinvent the wheel in terms of terminology, description and interpretation of the saw mark evidence.

Apart from its impracticality, this Sisyphean cycle has very pernicious consequences. First, the scarcity of terminology and documentation standards creates difficulty, if not sometimes impossibility in, the meaningful, effective presentation in court of saw mark evidence, as well as its objective evaluation by third parties. Secondly, by their own fuzzy and mutating nature, imprecise terminology and lax documentation standards are prone to result in imprecise or straightforwardly erroneous interpretations of the evidence. This, in turn, can lead to the spread of methodological and conceptual misconceptions.

Purpose, Goals and Objectives

The present research project was designed to address these problems by developing and presenting basic concepts; documentation protocols and analytical methodologies that enable more accurate and reliable analyses of saw toolmarks in hard tissues, particularly bone. Its target audiences are primarily first responders (e.g. medical examiners, coroners and law enforcement), responsible for the first evaluation of the potential evidentiary value of the human remains and of identifying the appropriate professionals for its analysis, as well as the professionals who will be asked to perform

these analyses (forensic pathologists and anthropologists.) However, a special effort is also made to present the basics of saw mark analysis of bone to tool-mark analysts. In the past (and, as established by the authors during the dissemination of this project), practicing toolmark examiners were largely unaware of the anthropological approach to saw mark analysis in bone, as developed and applied by Symes (1992). Consequently, this type of evidence, requiring a similar approach, but with key differences from other tool mark analysis, had not been part of their professional training. The authors consider it key for the further development of the field to link it more closely to the analysis of tool marks, learning from the long experience attained in this later field.

The key objectives of the project can be resumed as:

- 1) Developing and presenting a standard terminology, with clear definitions and graphic depictions of the main diagnostic traits to be considered in saw mark analysis.
- 2) Presenting basic standard protocols for the documentation and analysis of trauma, aimed at allowing both effective analysis and presentation of the evidence in court.
- 3) Clearing common misconceptions regarding the usefulness and types of information provided by some traits, like the major striations left by the inflicting tool.
- 4) Developing standards for the future assessment of the utility of new diagnostic traits for saw class characteristics, assessing the validity and presenting examples of different analytical and research approaches (such as morphological versus metric analysis), or purely observational designs versus the application of geometric models to analyze saw marks.

- 5) Assessing and validating the role played by inter-observer error and observer experience in basic morphological analyses, such as those aimed at determining whether the inflicting tool was powered by hand or was a mechanically powered saw. This would also serve to test the efficacy and user-friendliness of the trait and protocol descriptions in the produced manual.

From an operational point of view, the main practical output of these objectives is a basic manual to serve as a primer for the identification, documentation and analysis of saw mark evidence.

Research Design

The research design aimed at attaining these objectives was divided in two phases (*Phase I* and *Phase II*, hereafter), linked by the development of the trauma manual and the dissemination efforts, which overlapped both phases. Each phase also had a production component (manual development and dissemination), and an experimental component (aimed at testing different aspects of trauma analysis, as well as the effectiveness of the manual materials themselves.)

Phase I was primarily aimed at the development of the main graphic and written materials for the manual (in its production component), as well as testing the evidentiary value of major saw mark characteristics, and the relative advantages and potential of either a metric or a morphological approach to the analysis of basic class characteristics, like hand versus mechanically powered saws.

The main goals of *Phase II* were further refining the descriptions and materials contained in the manual, until its completion, as well as testing both the efficacy of the manual, and

the effect of inter-observer error and observed experience in the application of its main principles.

Dissemination, both through presentations at professional meetings and lectures and workshops directed at a wide array of forensic professionals, served a double purpose across both phases. First, the presentations reached a wide variety of forensic specialist audiences, helping to fulfill the dissemination goal. As mentioned above, this was one of the key needs addressed by the project.

Secondly, the lectures and presentations also served to assess the clearness, appropriateness and utility of the graphic materials and descriptions to be included later in the manual.

The feedback obtained during the nearly 50 of these talks and presentations delivered during the duration of the project proved invaluable in assessing the strengths and shortcomings of the different manual materials and approaches, the level of detail and technicality most appropriate to reach these audiences, and the technological and forensic needs and capabilities of most of the target agencies and professional offices. The generous feedback and collaboration obtained by the participants in these training and dissemination sessions served to improve tremendously the final result and to produce a manual which we believe will be useful for a much wider audience than we had initially envisioned.

Phase I

Manual development: This phase served to compile and develop the main materials for the manual, as well as, importantly, determining the best approach and level of detail to meet the needs and demands of the targeted audiences.

Detailed macro and micro photographs, casts and documentation were produced from both the existing Mercyhurst College comparative trauma collection, as well as from a new, more complete comparative sample developed under the project by applying different tools to a sample of human remains.

The latter was produced through the establishment of a formal relationship with a local medical school, which procured human skeletal tissue. The specimens obtained were cut with different saws, under a double-randomization design (both the sequence in which the remains would be cut, and the tools employed to do so were randomized.) The randomized design allows for the future use of the sample by other researchers, in validation studies or for any other analytical purposes, making very straightforward its inclusion in a wide variety of alternative experimental designs and its comparison with other existing or newly generated similar study samples.

The sample was then examined macro and microscopically, serving to obtain detailed photographs and schematic figures to illustrate the diagnostic traits and definitions in the manual and training presentations. Additionally, detailed example casts were produced at a new casting laboratory at Mercyhurst College, partially funded by a Lucas Grant from the Forensic Sciences Foundation, Inc., and by Mercyhurst College. All statistical analysis presented in this report were also based on this new comparative sample.

The materials produced in this fashion were integrated in a set of PowerPoint presentations and other instructional comparative materials (i.e. casts and real human samples to be presented as trauma examples during the lectures), which were then presented to different audiences of forensic specialists. This served to assess the

instructional value of the different materials, the efficacy and appropriateness of different presentation approaches, and the level of detail and minimum background to be assumed in the manual in order to meet the needs and demands of the main targeted audiences. The evaluation of the presentations assisted in the selection and development of the text and materials to be included in the manual. Around fifteen of these instructional sessions were presented to forensic anthropologists, medical examiners, pathologists, law enforcement, crime laboratories, fire marshals, tool mark analysts and other forensic specialists during the first year of the project (2005-2006) alone. As mentioned above, these presentations also served to assess the main technological and analytical capabilities of a wide variety of forensic and medico-legal laboratories, serving to adapt the protocols and manual contents to the most commonly available instrumentation and equipment. For example, as a result of these contacts, the protocols and graphic examples in the manual were adapted for their easier application with comparative microscopes, an instrument that was found to be more frequently available in forensic settings than the power microscopes usually employed in academic venues.

Setting the level of detail and assumed background best fitting the target audiences was particularly important as saw mark analysis is, by its own nature, a complex and massive subject. A basic search with the keyword “saw” in two major online home improvement stores rendered 901 and 822 different products, distributed in seven and 11 different categories, respectively.

Covering in detail all of these tools, or even all the different basic alternatives in general blade morphology, would require the development of a very large and complex comprehensive database, rather than an analytical manual. Setting the foundation for

the future development of this type of comprehensive database by providing standard terminologies, determining and defining the key variables to be targeted, and standard documentation and basic analytical protocols were precisely the main goals of this project, rather than constructing the databases themselves.

The problem of excessive detail is further complicated by the lack of previous literature and the diverse backgrounds of the target audience. Trauma analysis is better approached from a biomechanical perspective. Unlike other tool marks and evidence impressions, saw marks are strongly influenced not just by the morphology of the inflicting tool, but also by physical parameters such as force, speed and orientation. However, comprehensive biomechanical and dynamic interpretations might overwhelm professionals lacking the appropriate background. Therefore, identifying the basic class characteristics, the level of detail to be addressed in the manual, and its appropriate extent was paramount to make it a useful tool for the different intended audiences.

Experimental Component: The main experimental component of Phase I was aimed at (1) demonstrating and warning about common misconceptions affecting saw mark analysis, (2) testing the potential of metric methods, as compared to morphological criteria, to analyze and identify basic tool class characteristics, (3) illustrating the influence of physical parameters such as force, speed and position over saw mark impressions, and (4) demonstrating the application and value of different research alternatives, mainly those of working with or without previous geometric models.

The main horizontal striations left by saws when cutting through bone tissue were selected for this study for several different reasons. First, as will be discussed below in some more detail, these striations are useful to reveal the most basic class distinction,

between hand and mechanically powered saws. Therefore, their assessment will represent the more basic, first step of saw mark analysis.

Secondly, these marks are the most commonly found and evident of the impressions left by saws on hard surfaces. As a matter of fact, it will usually be through these macroscopic impressions that the observer will identify the cut surface as produced by a saw-like tool, even in the absence of any previous training. Due to this familiarity and easy macroscopic detection, these types of marks often attract the attention of novel analysts.

One particularly appealing temptation in these situations is using the macroscopic long striations as the reference to assess the level of match, when replicating the cuts with the suspected inflicting or an identical tool. In the present research, saw mark striation patterns produced with the same tool, by the same researcher, at different times were compared to test the expected level of match in these situations, if any. This also served to discuss and illustrate the nature and extent to which different physical variables and factors, independent of tool morphology, can affect saw mark impressions, as well as the importance of taking all these factors into account in saw mark analysis.

On the other hand, as already noted above and by Symes (1992), the general patterns of these impressions are useful to distinguish between hand and mechanically powered tools. In this study, two sets of impressions in bone, generated from random samples of hand and mechanically powered saws, were compared to assess whether these morphological pattern differences could be better determined metrically. This comparison was carried out in two independent ways, which serves as a proposal and

practical demonstration of two different methodological approaches for the metric study of saw marks in hard organic tissues.

In the first comparison (*pilot study*), the target traits were directly measured from microscopic photographs of the impression, in the absence of a detailed model. A second comparison was then performed after the incorporation of a simple geometric model which was intended to control for the noise introduced in the analysis by factors such as the orientations of the saw cuts and photographs. The construction and rationale of the geometric model is described in detail in the project narrative and serves to illustrate the ease of application and higher statistical power rendered in this area by model-based analyses over black-box studies. A detailed description of these analyses and results is provided in the project narrative.

Phase II

Manual development: Using the materials produced during Phase I, Phase II was mostly devoted to the final compilation and completion of the manual based on the feedback obtained from the dissemination talks and seminars, to which more than 30 new ones were added during this phase.

It was also during this phase that a webpage was developed (with all contents already completed and pending only final technical adjustments and publication) to complement the manual. The webpage is intended to serve as a tool to keep dynamically improving and adding contents to the manual, based on the feedback and information provided by the users, as well as from the continued research and casework of the authors.

Experimental Component: The experimental component in *Phase II* was aimed at (1) testing the reliability of morphological saw analysis of the most basic class characteristics, based on the results obtained in *Phase I*, which suggested the superiority of this approach over metric analysis, (2) testing the effect and extent of inter-observer error, depending on the relative difficulty or ease of identification of different tools, and (3) testing the effect and extent of intra- and inter-observer error, depending on the level of experience and exposure to the manual of the observers.

Hand versus mechanically powered saws was selected for this analysis, following *Phase I* and as the most basic class category assessment. In this analysis, different groups of observers were assigned microscopic photographs of either hand or mechanically powered saws and the groups were tested for significant differences in the rates of correct classifications, depending on different treatments and factors.

An initial test (*Phase 2A*) served to estimate the percentage of correct classification (success rates) after an initial lecture and description, using the materials corresponding to the appropriate section of the manual. After a time span of several weeks, a sample of the original participants repeated the exercise (*Phase 2B*) with a different set of bones, tools and microscopic photographs, comparing their success rates with those obtained by themselves in the original exercise. A control sample was also included in this exercise and represented individuals who confronted the manual and practical exercise for the first time. The second comparison served different purposes. It first served to assess the differences between novel and more experienced analysts. Self comparison served to control for biases derived from differences in individual abilities between samples, as well as to assess the effect on the results of individual abilities and predisposition. The double-control design (from the “novel” control groups in both

exercises) served to control for biases derived from differences in the brief instructional sessions, as well as for establishing reliable confidence intervals for the success rates.

Self-comparisons also served to establish a clear and reliable criterion to distinguish between more and less experienced observers. The former would be those who had been previously exposed to the manual and saw analysis, having had several weeks to study the manual and related materials and who had received an extra “refreshing” lecture on the subject. As mentioned above, the number of practitioners with long experience and expertise in saw mark analysis is comparatively small to those with little or no experience. This left little available in terms of alternatives to construct balanced samples of “experts” and “novices” from current practitioners.

The samples were also compared in terms of correct classifications of each individual tool and tool type, in order to assess and control for differences derived from the higher or lower difficulty posed by each tool for its classification. A detailed description of these analyses and results is provided in the project narrative.

Findings and Conclusions

The main output of this research project is the attached basic manual, to introduce the reader and assist in the identification, documentation and analysis of saw mark evidence. The information in the manual is directed toward a widely educated audience. In its production, we tried to balance a direct tone and accessible explanations of the key concepts aimed at the wide array of forensic professionals who will not be analyzing the evidence, but will be employed in the decision making process to interpret its potential relevance and contact the appropriate specialists for its analysis. The manual is not intended to be a comprehensive review for the classification of one and all saw marks

produced by the incredibly wide array of potential tools as this would be almost impossible. We consider the manual to act as a primer to standardize terminology, documentation and analytical protocols in order to set the foundation for the development of more comprehensive databases and textbooks. The manual provides:

1. A comprehensive “user-friendly” handbook, accessible to a wide audience, aimed at increasing the awareness on diagnostic saw and knife mark characteristics, analytical techniques, documentation procedures, and reporting protocols.
2. More precisely defined and described diagnostic characteristics useful in the analysis of knife and saw marks in bone.
3. Standards for assessing saw mark characteristics. In order to provide a methodology that meets criteria for admissibility of scientific evidence, standards for each variable and the criteria for evaluating/measuring each variable must be defined.
4. A documentation standard for cut marks in bone in the forensic setting. While the best approach is to retain the bone as evidence, medical personnel sometimes meet this with reluctance. Better documentation standards of the evidence before burial or cremation will enable the most accurate recovery of toolmark evidence. The proposed documentation process for all sharp traumas will include casting, photography, and microscopic analysis.
5. Finally, while not in the original proposal, we are in the final stages of completing and making a website available with most of the manual contents. The website will be linked to Mercyhurst College, the Mercyhurst Archaeological Institute, and Dr. Symes’ personal website. It is intended to be a dynamic collection point for new manual data and photographs of our experimental cuts and casts, as well as, a venue for communication with those investigators looking for assistance in a dismemberment/mutilation case.

The experimental component of the project served to reveal and discuss key components of saw analysis, including some key sources of bias, common misconceptions, and the proposal of different research venues for the future development of the field.

The analysis of the primary macroscopic striations that usually offer the first clue to identify a particular cut mark as a saw mark demonstrates that even the same operator can produce very different macroscopic striation patterns with the same tool. This illustrates the extreme effect of physical factors such as applied force, speed and even posture of the operator on macroscopic saw mark morphology and, therefore, the need for more detailed microscopic analyses.

This study also served to demonstrate the difficulty of translating useful saw mark diagnostic morphological traits into metric variables, even when the grossest and most evident morphological patterns are analyzed. While metric approaches may be useful to determine variables like teeth per inch or blade breadth (these being metric variables themselves), morphological analysis appears as the best option to identify general tool classes (hand versus mechanical power, blade shape, etc.)

The initial battery of tests illustrated the utility and general application of geometric models in saw analysis. In this particular case, the model served to prove that the lack of success in distinguishing metrically between hand and mechanical powered saws was not due to measurement problems (i.e. to the way or particular orientation in which we measured our variables), but to the intrinsic variability of the trait under examination. However, it is possible that, in other cases, the control on confounding variables (force,

orientation, etc) exercised by the geometric model may suffice to eliminate this noise and detect the desired effect or underlying pattern.

The experiments in *Phase II* demonstrated first that basic, but extremely useful successful preliminary assessments of saw marks are possible with minimum training when following the manual. No significant differences in success rates appeared between more and less experienced observers, suggesting that at least at this basic level the learning curve is rather steep.

Similarly, the comparison between the repeated measurement (self comparison) and control samples did not reveal any dramatic differences in individual abilities and success rates, resulting in consistent distinctions between “gifted” and “poor” observers. When the appropriate protocols are followed, and the evidence is examined in a methodical, hierarchical way, all of us are able to produce consistent results.

Differences were found in the difficulty to classify different tools, highlighting even further that continued research in the field and, in particular the systematic examination, documentation and sharing of data relative to individual tool types is badly needed. Hopefully the attached manual will serve to ease this task by standardizing the way in which all this information is termed, recorded and analyzed by future saw analysts.

Finally, a third but important output of this project is derived from the dissemination efforts, which have come to increase the awareness on the importance, application and possibilities of saw mark analysis in bone among not only forensic anthropologists and pathologists, but the forensic community at large.

During the duration of the project, presentations have been given nationally and internationally to crime lab personnel, anthropologists, pathologists, forensic scientists, and prosecutors/public defenders (see Table III-1 below). It is interesting to note that anthropologists and pathologists do not traditionally perform 'toolmark analysis' and toolmark examiners rarely deal with bone. To our knowledge, this project has represented the first attempt to bridge this gap, integrating saw mark analysis in bone to these areas of expertise, while informing the judiciary of its potential.

We expect that the common ground provided by the provided manual will help to further increase not only this awareness but the communication and cooperation of analysts from diverse fields in future research and criminal investigations.

PART II: PROJECT DESCRIPTION

Materials and Methods of the Sample

Sample Description

The sample consists of 19 human long bones (humeri and femora), from six individuals, donated by the Director of the Lake Erie College of Osteopathic Medicine (LECOM) Willed Body Program, in Erie, PA. The cadavers were specifically donated for the purpose of education and research. The osteological samples used for this project were taken from those bodies in which the families did not request the return of ashes. Dr. Jonathan K. Kalmey, Assistant Professor of Anatomy at LECOM, and his staff removed the long bones after dissection.

Processing and Preparation

The bones (along with the cadavers) were originally fixed in a 2% formaldehyde solution that was largely composed of ethylene glycol. Each long bone was processed to remove any remaining soft tissues by immersing them in a solution of hot (nearly boiling) water, laundry detergent, and a small amount of bleach (approximately four ounces). Tissue was removed, to the extent possible, from the shaft and ends of each long bone. After processing and subsequent drying, each bone was labeled with a unique number (1-19) using an orange plastic tag (Table II-1). Each bone was measured using the standard measurements established by Buikstra and Ubelaker (1994) (See Appendix II-A for a complete list of recorded measurements). These labels were used to ensure that demographic information and measurements could later be linked to each specimen. After being labeled and measured, photographs were taken of each long bone to complete the documentation (Figure II-1).

Table II-1. This table is a breakdown of demographic information and assigned sample numbers for each individual/group.

<i>Individual/Group</i>	<i>Sex</i>	<i>Age</i>	<i>Contents</i>	<i>Assigned Numbers</i>
A	M	50	1 femur; 2 humeri	1: femur (right) 2: humerus (right) 3: femur (right)
B	M	90	2 femora; 1 humerus	4: femur (right) 5: femur (left) 6: humerus (left)
C	M	?	1 femur; 1 humerus	7: femur (left) 8: humerus (left)
D	M	91	1 femur; 2 humeri	9: femur (left) 10: humerus (right) 11: humerus (left)
E	F	59	2 femora; 2 humeri	12: femur (right) 13: femur (left) 14: humerus (right) 15: humerus (left)
F	?	?	3 femora; 1 humerus	16: femur (right-incomplete) 17: femur (right-incomplete) 18: femur (left) 19: humerus (left)

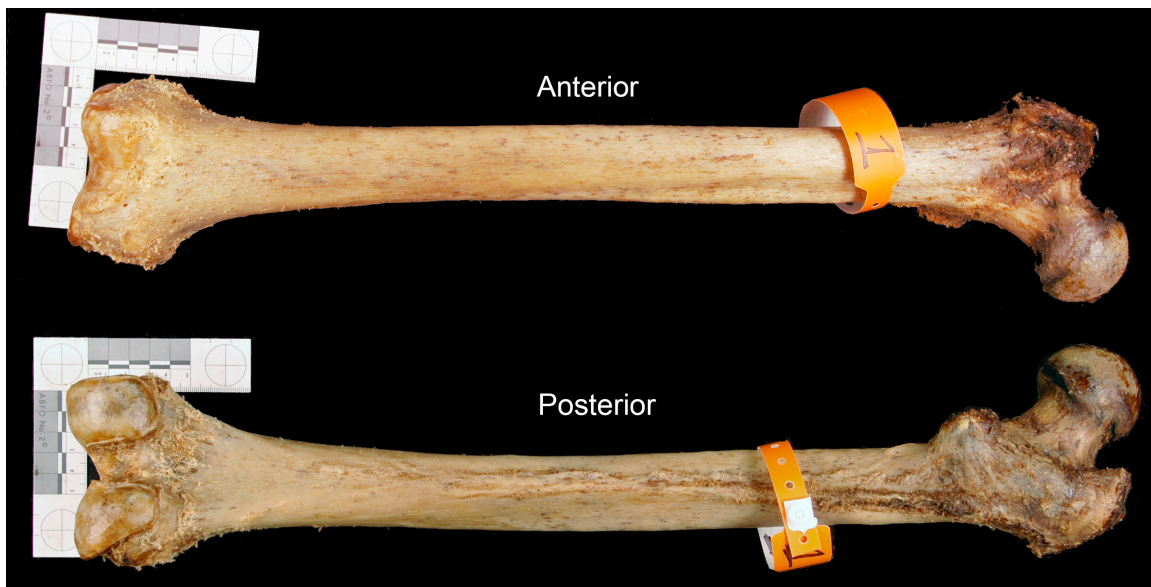

Figure II-1. An example of the anterior and posterior view photographs taken for each long bone prior to sectioning.

Description of Saw Sample

Twenty-seven saws were selected for use in the study. Each saw was selected in order to represent numerous variables such as, teeth per inch, power stroke, tooth height, tooth set, etc. The saws that were selected for use in this study were chosen to be representative of the wide variety of saws available on the commercial market today. Each saw was cataloged, labeled using an engraver and permanent marker, and measured. A number of variable were measured for each saw such as: teeth per inch, blade length, tooth height, tooth width, tooth set, etc. Measurements and descriptions for each saw were compiled in an *Excel* spreadsheet (Appendix II-B). The saws used in the study were labeled with numerals from 100 to 126, to facilitate the direct comparison of results with those in previous dissertation research by the Principal Investigator in 1992, in which the tools analyzed were labeled with numerals below 100.

Sample Randomization

A random sequence of cuts was generated using the 19 donated long bones (labeled 1-19) and 27 saws (labeled 100-126) in the sample. For each long bone, 15 randomly generated saws were selected to make the cuts using *Excel*. See Table II-2 for an example of the cutting sequence created for one long bone. The randomized saw order

Table II-2. An example of the random cutting sequence created for one long bone. represents the cutting sequence that was utilized to create the bone sections.

Cut Number	Bone Number	Saw
1	1	123
2	1	122
3	1	111
4	1	116
5	1	104
6	1	115
7	1	116
8	1	103
9	1	124
10	1	119
11	1	112
12	1	104
13	1	108
14	1	111
15	1	121

Cutting Methodology and Sample Preparation

The sequence in which the cuts were made was randomly generated in order to maintain randomization standards and eliminate potential bias based on the sequence of cutting. The cut bone sections contributed to two collections (the study sample and the comparative collection). Bone sections in the study sample were used for all statistical analyses, eliminating potential bias (cutting order and saw wear) while fulfilling randomization. Bone sections placed in the comparative collection were created for future research and educational purposes. See Figure II-2 below for a visual depiction of the sample creation. For example, if the order of randomized saws was 123, 122, 111, etc; the first cut was

made using saw 123 and the second cut and false starts (on the surface of the shaft) were made using saw 123. This would produce a bone section in which both cut surfaces and the false starts were made using saw 123.

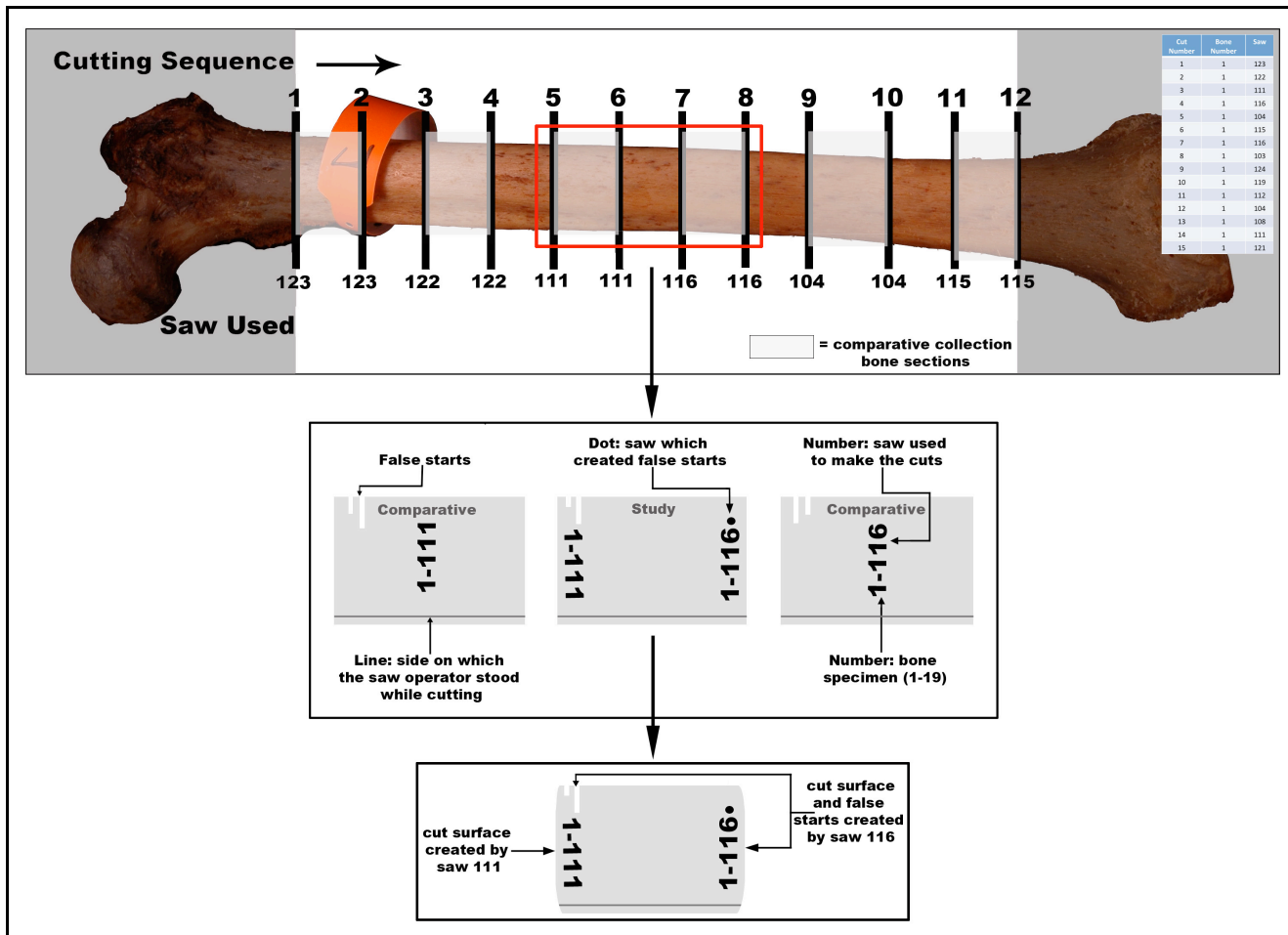

Figure II-2. Top: represents a cutting sequence and production of the analysis sample and the comparative collection of bone sections. Middle: Notice how each bone section is labeled. Bottom: depicts a single study sample bone section.

The bone section was placed into the comparative collection. The false starts and the next (third) complete cut were made with saw 122. This bone section has one cut surface made by saw 123, and false starts and a complete cut made by saw 122. This bone section was used for the study sample.

Before each long bone was cut, it was fit securely into a vice and a line was etched, using an engraver, along the entire shaft of the bone on the side in which the operator

would be standing during the cutting process. In other words, the line engraved on the bone represented the side in which the handle of the saw was on during the process of cutting.

In order to best utilize the entirety of the bone, each was cut from the proximal end to the distal end or from distal to proximal. In most cases, however, cutting proceeded from proximal to distal. In order to ease documentation, bones were also cut with the saw operator standing either on the lateral or medial side of the bone. Each bone (1-19) was cut using a randomly selected saw (100-126) as many times as possible given the length of the bone. All information regarding the cutting sequence and protocol was recorded for each bone.

Each cut bone section was labeled with pencil immediately after being produced. Individual bone sections were then further processed in hot water (nearly boiling), detergent, and a small amount of bleach in order to remove additional grease and formalin. Each bone section was labeled with indelible ink after drying. Bone sections were subsequently stored in plastic containers with individual compartments (each compartment was also labeled).

Description of Study Sample

A total of 121 bone sections were produced for the study sample, resulting in a total of 242 cut surfaces (two cuts per bone section with one bone section only having one cut surface). See Table II-3 for a breakdown of the number of cut surfaces created with each of the 27 saws in the sample.

Table II-3. Breakdown of the number of cut surfaces created for each saw

Saw Number	Number of Cut Surfaces
100	4
101	13
102	8
103	12
104	7
105	12
106	6
107	8
108	11
109	8
110	10
111	9
112	9
113	7
114	7
115	9
116	8
117	11
118	7
119	6
120	12
121	12
122	13
123	5
124	11
125	7
126	9
TOTAL	241 cut surfaces

Metric versus Visual Assessment of Hand and Mechanically Powered Saws

The purpose of the study was to: (1) compare the accuracy of metric analyses versus visual assessments of saw power and, (2) to determine if saw power analysis could provide other information regarding the inflicting tool. For the purposes of the study and the project, saw power is defined as the mechanism that is used to power the tool. In the study the authors attempted to differentiate mechanically powered tools from hand powered tools based on characteristics seen in cut bone.

An increased necessity for scientific work to meet Daubert Standards in the courtroom has provided impetus for this study. Accurate visual assessment is based on experience in sawmark analysis in bone (Symes 1992). The authors attempted to determine if there is a more accurate and less subjective way of determining saw power. Using a metric analysis to separate saw classes, the authors thought it would partially eliminate

subjective bias, creating a more objective way of diagnosing saw power, independent of the analyst's experience. The authors were also interested in ascertaining additional information from a metric assessment of saw power, such as, a teeth per inch estimation.

Based on past research by the first author (Symes 1992), mechanically powered saws were more likely to create uniform striation patterns on a cut surface wall. Due to the high rate of speed at which a mechanically powered saw blade is moving the change in striation direction is less likely to occur in consecutive striations and more likely to exhibit a group of striations in a single direction. The uniformity and changes in striation direction or angle were evaluated.

The authors of this study tested what factors influence how striation breadth is created (i.e., tool, TPI, etc.). For the purpose of this study striation breadth is defined as the width of one complete striation on the cut bone surface. The study also attempted to determine: (1) how striation breadth correlated with specific saws; (2) assessed the accuracy of inexperienced observers in evaluating saw power; and (3) determined whether different types of tools and toolmarks were harder to correctly classify, or whether classification was dependant upon the observer.

Historically saw the operator has supplied saw power physically. Variation in speed, strength and skill of the operator are present when a tool is powered by hand. Mechanically powered saws have become more common due to mass production of low quality power saws. Although, hand powered saws are still more commonly used in cases of dismemberment.

Differences observed between mechanically and hand powered saws observed in cut bone occur due to the design and structural elements of the two types of saws. In other words, source of power (mechanical or hand) influences the saw and the sawed byproducts. The principles of cutting action rely on blade and tooth design, and the manner in which energy is transferred (See **Sawmark Analysis Manual** in Part III of this report).

Mechanically powered saws are designed to cut in a reciprocating or continuous motion. There is a reduction in human variation with an increase in speed and uniformity of the cut. The added speed and torque provided by mechanically powered saws dictates the tooth design. Mechanically powered saws typically have a short blade and wide teeth. The increased speed of a mechanically powered saw creates more material waste in the cut.

The blade and tooth design of hand-powered saws are variable. Typically the blade is less robust than a mechanically powered saw because there is less torque applied to the blade during the sawing motion. Variation is increased in the sawed byproduct due to disparity in skill of the operator, changes in the speed at which the saw is used, and variation in the amount of force that is applied to the blade. Typically a complete cut is accomplished at a slower rate due to the fact that the operator supplies the power. In general, a hand powered saw produces less material waste than a mechanically powered saw because the blade is thinner. Figure II-3 below represents the phases of the study.

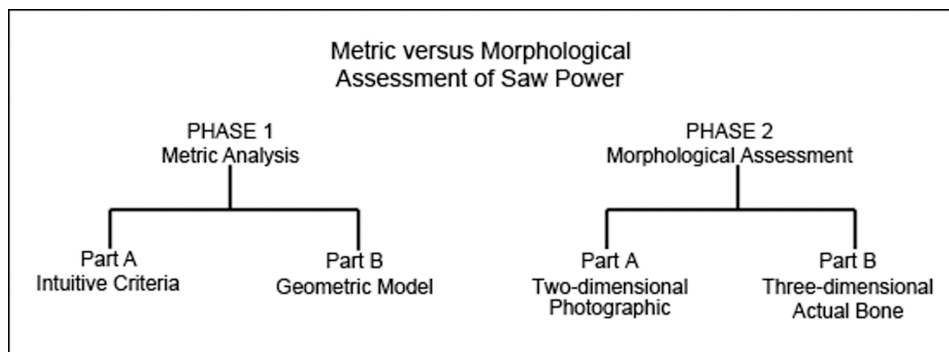

Figure II-3. Depicts the research phases in the study.

Phase 1-Part A: Pilot Study for a Metric Assessment of Striations

From the study sample of 121 bones sections, a random sample of 14 bone sections was chosen for Part A. Each bone section has two cut surfaces, rendering a total of 18 cut surfaces created by mechanically powered saws and ten cut surfaces created by hand powered saws (See Table II-4). See Table II-5 for a list of specifications for each saw used in the pilot study.

Table II-4. Randomly generated bones sections for pilot study. Saw numbers listed in blue represent mechanically powered saws and saw numbers listed in black represent hand powered saws.

Bone Number	Bone Sections
16	123-100
9	103-124
1	122-111
8	116-121
8	105-122
6	123-106
13	124-113
9	117-103
5	125-102
1	123-122
17	120-102
5	121-120
7	126-124
12	125-109

Table II-5. List of specifications for each saw used in the pilot study. Note the wide range of variables for each saw.

Saw	Hand/Power	TPI	PPI	Set Type	Tooth Type	Direction of Cut	Blade (Saw) Name
100	Hand	18	19	ALT	CUT	PULL	Fine Finish Work Pull Saw (extra fine tooth)
102	Hand	11	12	ALT	CHISEL	PUSH	X-tra Fine Cut Veneer & Laminate Fine Tooth Saw
103	Hand	8	9	ALT	CUT	P/P	Jab Saw
105	Hand	9	10	ALT	CHISEL	PUSH	Compass Saw
106	Hand	23	24	WAVE	CHISEL	PUSH	Metal Cutting Saw
109	Hand	13	14	ALT	CUT	PULL	General Carpentry
111	Hand	24	25	WAVE	CHISEL	PUSH (PULL)	Junior Hacksaw
113	Hand	15	16	ALT	CHISEL	PUSH (PULL)	Coping Saw (Medium)
116	Power	140 teeth		ALT	CHISEL	PULL (?)	Circular (Hollow Ground for: Plywood, Plastic, Laminates); 7 1/4 Diameter
117	Power	24 teeth		ALT	CHISEL	PULL (?)	Circular (Plywood, Plastic, Laminates); 7 1/4 Diameter
120	Power	6	7	RAKER (7th)	CHISEL	PULL	Reciprocating (Wood/Demolition)
121	Power	8	9	WAVE	CHISEL	PULL	Reciprocating (Demolition)
122	Power	14	15	RAKER (6th)	CHISEL	PULL	Reciprocating (Metal Cutting)
123	Power	14	15	RAKER (3rd)	CHISEL	PULL	Reciprocating (Metal Cutting)
124	Power	24	25	WAVE	CHISEL	PULL	Reciprocating (Fine) w/ Ryobi
125	Power	10	11	RAKER (3rd)	CHISEL	PULL	Reciprocating (Medium) w/ Ryobi
126	Power	40 teeth		ALT	CHISEL	PULL (?)	Circular (Fine Cutting) w/ Skilsaw; 7 1/4 Diameter

Using *ForensicSil*, a negative impression was made of each cut surface in order to improve the visibility of striations and reduce any background noise created primarily by reflection. Each negative impression was photographed (including a scale with 0.5 mm increments) using a *Leica MZ16 A* stereomicroscope and *Image Pro 5.1 (2004)* software. Approximately two to five millimeters of each impression were photographed and the magnification was recorded. In general, the authors attempted to photograph the area near the middle of the cut surface in order to: (1) standardize the area in which the measurements were being taken and (2) maximize the number of striations that can be viewed, as this area is often the thickest area of the bone and should therefore yield the highest number of consecutive striations (Figure II-4).

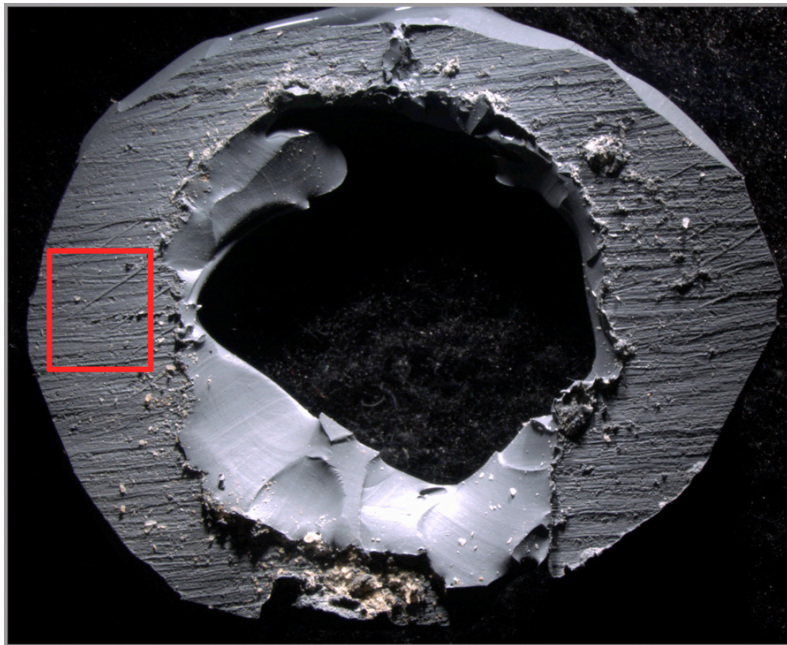

Figure II-4. This figure is an example of the area in which microscopic photographs were taken of each.

Each photograph was processed using *Image Pro 5.1 (2004)* software. Using *Image Pro 5.1 (2004)*, the scale was calibrated for each photograph. A box was placed in the image to standardize the measuring technique employed, as well as serve as a base from which striation breadth and angle measurements were taken. Striation breadth was recorded for each photograph by measuring the perpendicular width between consecutive striations starting from the line of the box. Length measurements (distance between striations/ striation breadth) were taken from border to border between striations. The distance between consecutive striations was recorded for striation

breadth along the inferior border of the box. Total length measurements were noted for the length of the box on the superior and inferior border. Figure II-5 is an example of a measured image.

Total length measurements were used to compare the measured striation breadth of the superior versus inferior border of the box. It was postulated that changes in the angle of the striation (striation variability) could be calculated from this comparison.

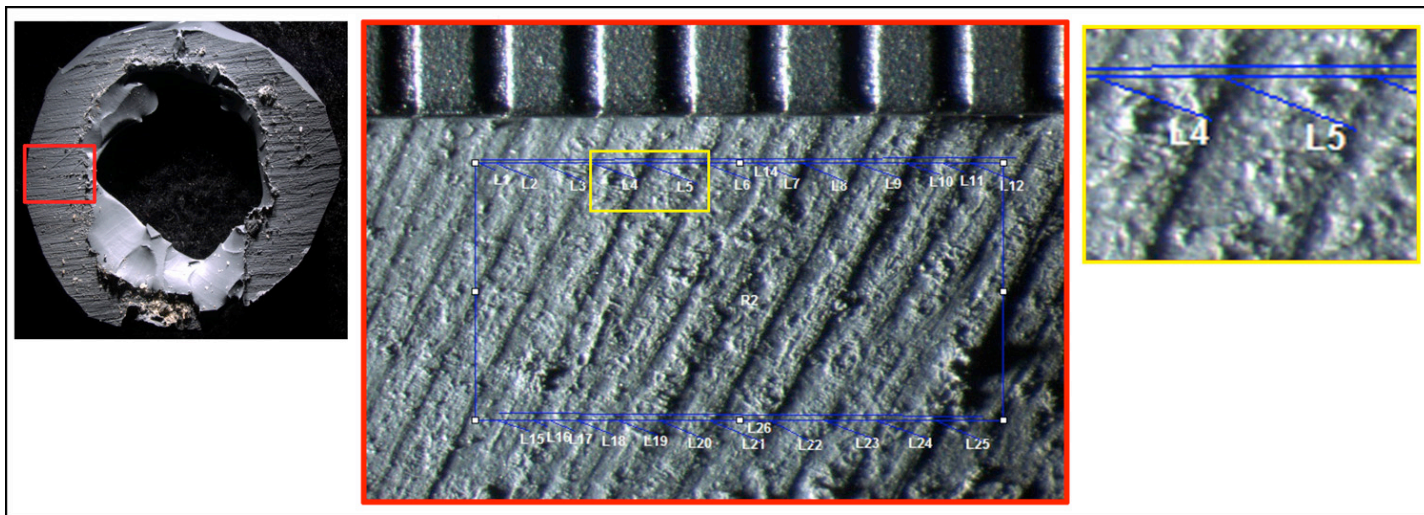

Figure II-5. Above is an example of a measured image from the first round of measurements. L1 – L12 represent the distance measurements (width of each striation). L15- L25 represents the distance between striations for the inferior border of the boxed area. L14 and L16 represent the overall length of the measured area of bone.

Phase 1-Part B: Metric Assessment of Striations based on a Geometric Model

After initial analysis and interpretation of data collected in Part A, the authors modified the protocol in order to increase its reliability and its repeatability. Difficulty in Part A arose when attempting to measure striation breadth perpendicular to the width of the striation. The authors identified the subjectivity in making repeatable measurements. The design of the measurement collection in the pilot study gave a false impression of striation breadth if the angle of consecutive striations changed. The protocols for the measurement collection were modified for two reasons: 1) the exact perpendicular was difficult to measure and 2) the protocols used in Part A did not account for changes in striation angle.

For the purposes of the study striation angle or the angle between consecutive striations is defined as the striation variability. The striation breadth, as previously defined, is the

distance between two consecutive striations. In the pilot study, the protocol employed did not account for striation variability. The striation breadth is a measure of the consistency of the cut or the uniformity of the striations and the striation variability accounts for the changes observed in the direction of the striations (Figure II-6).

According to past research both mechanically powered saws and hand-powered saws exhibit changes in striation direction in the cut bone surface. This change in striation direction is equivalent to changes in the direction of the cutting stroke. When using a hand-powered saw, in theory every stroke (or striation) could potentially be at a different angle because a person is supplying the power. Patterned consecutive striations are observed in mechanically powered saws because they are moving at a high rate of speed. The direction of striations can still change depending on the angle of the cutting surface but patterned striations (multiple striations with the same angle) are more likely to occur with mechanically powered saws.

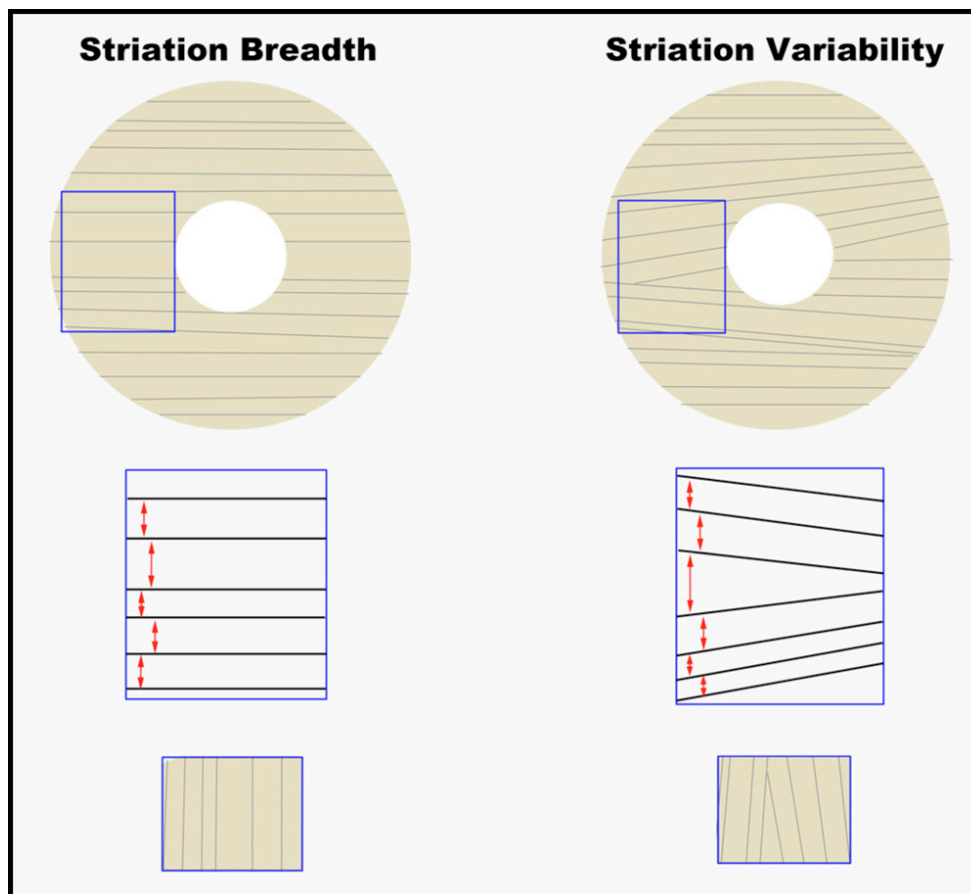

Figure II-6. On the left, striation breadth is depicted. The original design for Part A was only able to account for differences observed in the breath or width of consecutive striations. The image on the right depicts the flaw in the design for Part A. The variability in striation angle between consecutive striations gave an incorrect measurement for striation breadth in situations in which the angle at which the saw struck the bone left changes in the direction of the striations.

By analyzing the uniformity of striations using a method based on geometry (see protocol description below), the authors aimed to produce accurate results and a repeatable protocol. For Part B, 12 bone sections were randomly selected, producing 14 cut surfaces made by mechanically powered saws and ten cut surfaces made by hand powered saws (Table II-6). See Table II-7 for a list of the specifications for the saws used in Part B.

Table II-6. List of bones sections randomly selected for use in Part B of Phase 2.

Bone Number	Bone Sections
15	117-109
1	124-119
13	105-121
4	120-108
15	104-117
3	124-120
5	102-124
17	103-101
16	108-122
10	110-125
5	126-121
14	121-106

Table II-7. List of specifications for saws used in Part B. Note the wide range of variables.

Saw	Hand/Power	TPI	PPI	Set Type	Tooth Type	Direction of Cut	Blade (Saw) Name
101	Hand	11	12	ALT	CUT	P/P	Utility saw
102	Hand	11	12	ALT	CHISEL	PUSH	X-tra Fine Cut Veneer & Laminate Fine Tooth Saw
103	Hand	8	9	ALT	CUT	P/P	Jab Saw
104	Hand	11	12	ALT	CUT	P/P	Finish Blade
105	Hand	9	10	ALT	CHISEL	PUSH	Compass Saw
106	Hand	23	24	WAVE	CHISEL	PUSH	Metal Cutting Saw
108	Hand	8	9	ALT	CUT	PUSH (tri-bevel design)	Rip Saw
109	Hand	13	14	ALT	CUT	PULL	General Carpentry
110	Hand	15	16	ALT	CHISEL	PUSH	Back Saw (Crosscut??)
117	Power	24 teeth		ALT	CHISEL	PULL (?)	Circular (Plywood, Plastic, Laminates); 7 1/4 Diameter
119	Power	5	5/8	RAKER (7 th)	CHISEL	PULL	Reciprocating (Wood/Demolition)
120	Power	6	7	RAKER (7 th)	CHISEL	PULL	Reciprocating (Wood/Demolition)
121	Power	8	9	WAVE	CHISEL	PULL	Reciprocating (Demolition)
122	Power	14	15	RAKER (6 th)	CHISEL	PULL	Reciprocating (Metal Cutting)
124	Power	24	25	WAVE	CHISEL	PULL	Reciprocating (Fine) w/ Ryobi
125	Power	10	11	RAKER (3 rd)	CHISEL	PULL	Reciprocating (Medium) w/ Ryobi
126	Power	40 teeth		ALT	CHISEL	PULL (?)	Circular (Fine Cutting) w/ Skilsaw; 7 1/4 Diameter

Negative impressions were made of each cut surface using *ForensicSil*. Photographs were taken of each impression using a *Leica MZ16 A* stereomicroscope and *Image Pro 5.1 (2004)* software. Adjustments were made to the levels and the contrast of the images using *Adobe Photoshop Creative Suite 3 (2007)*. No alterations to the image content were made, and the images were merely enhanced for optimal viewing in order to ensure accurate measurements of each striation. After preparation, the images were measured using *Image Pro 5.1 (2004)*.

Using the red box as a basis or guide, the uncorrected distance between two striations was measured and recorded. Next, the distance between the superior and inferior border of the box was measured and recorded. The angle between the two measured distances was calculated using *Image Pro 5.1 (2004)*. Figure II-7 is an image after enhancement was completed and measurements were taken using the geometric method. Figure II-8 is a close-up view of the measurements that were recorded using *Image Pro 5.1 (2004)*. The Pythagorean theorem was used to estimate the distance between two consecutive striations (adjacent side), perpendicular to the initial striation (opposite side), based on the measured uncorrected distance between two striations (the hypotenuse of the corresponding triangle) and the angle formed by this measurement and the initial striation (see Figure II-9).

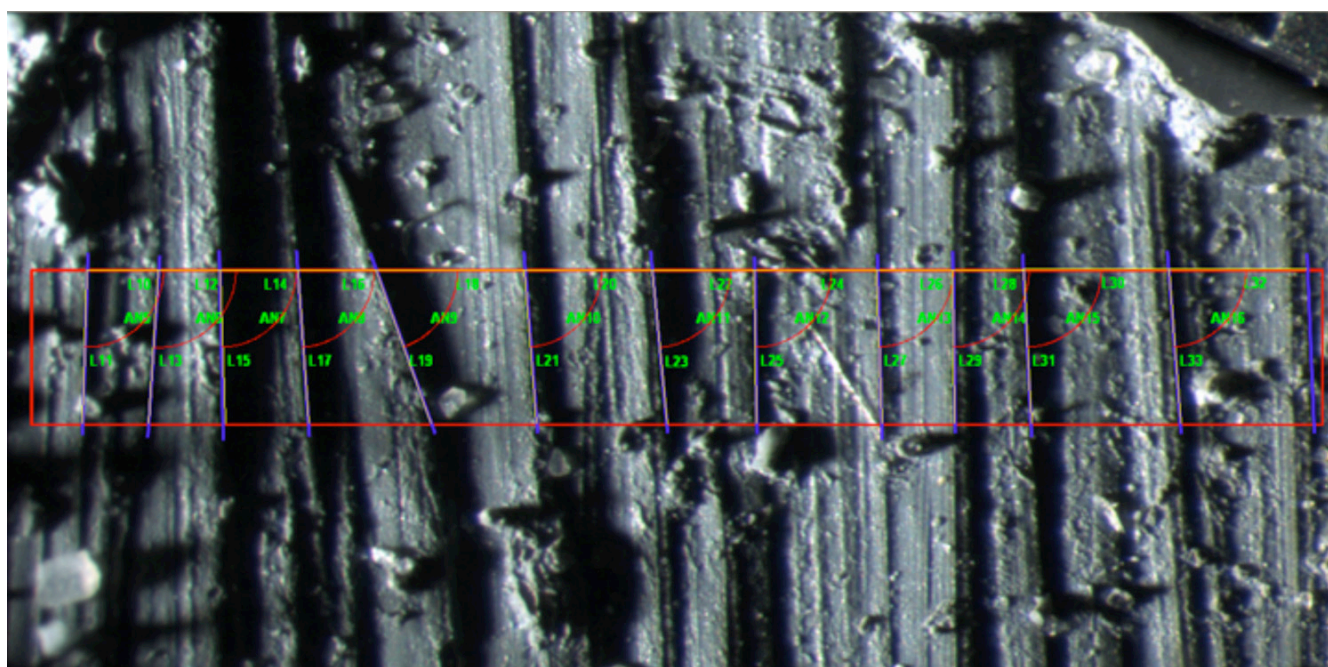

Figure II-7. An example of an image measured using the geometric method.

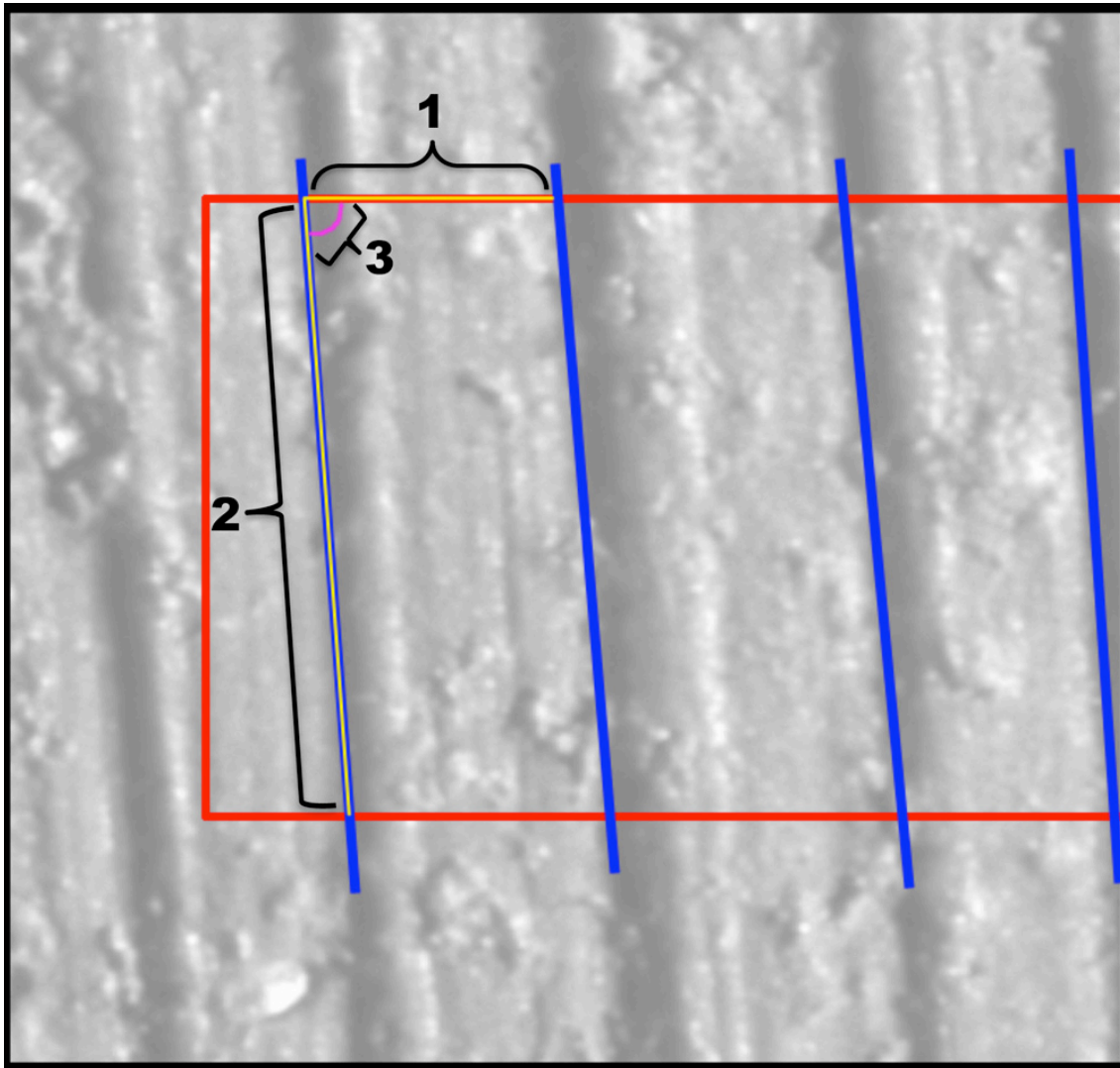

Figure II-8. This figure is a close-up view depicting the three measurements that were recorded for each striation. Measurement (1) is the striation breadth or the total width of the striation; (2) is a fixed length of the striation that was arbitrarily designated for all measured striations on a given *ForensicSil* impression. Placing a red box in each image created this measurement. The changes observed in this measurement correlated to changes in the angle of the striation; (3) is the angle at which the striation crosses perpendicular to the direction of the cut. Changes in the angle measurement were used to assess the direction of the cut from one striation to the next consecutive striation. In other words, measurement (3) gives the change in direction of consecutive striations.

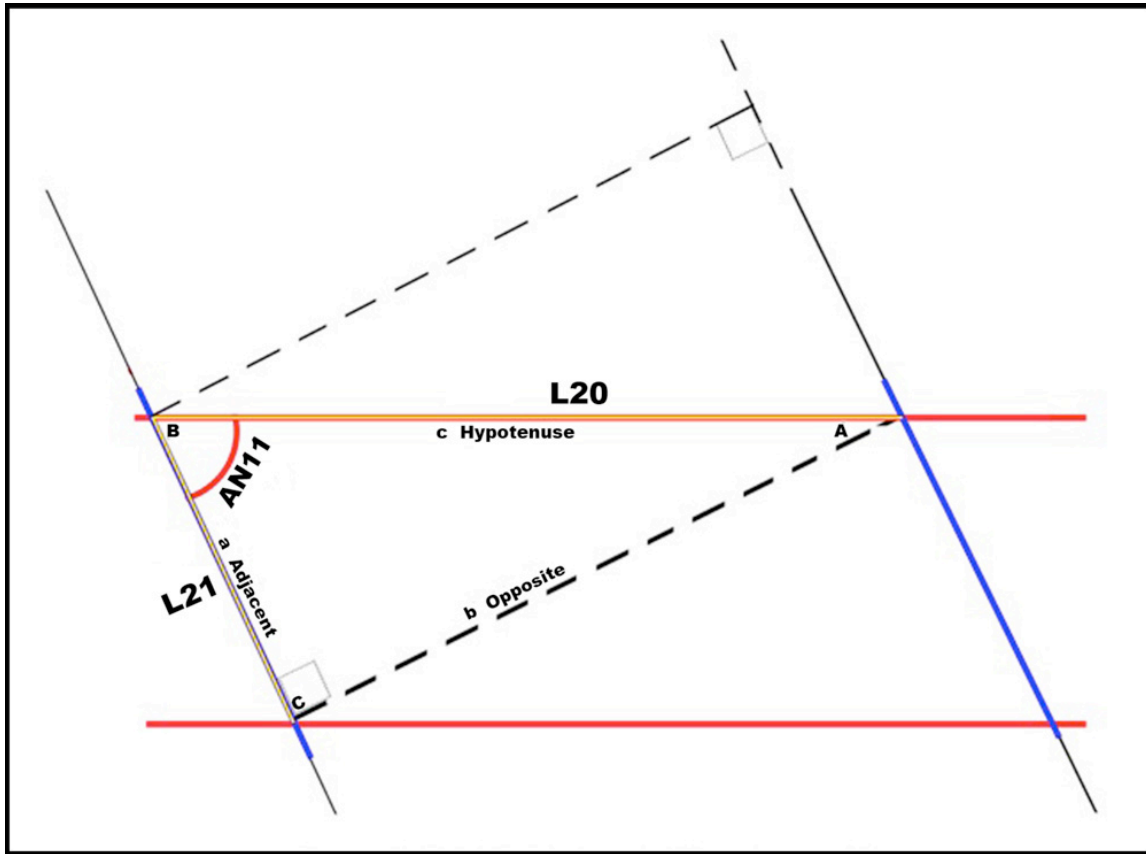

Figure II-9. Three measurements were recorded for each striation, for example, in the figure above, L20 (line 20) in yellow, L21 (line 21) in yellow, and AN11 (angle 11) in red. The Pythagorean Theorem was used to estimate the distance between two consecutive striations (opposite side), perpendicular to the initial striation (adjacent side), based on the measured uncorrected distance between two striations (the hypotenuse of the corresponding triangle) and the angle formed by this measurement and the initial striation. L20 is the raw breadth measurement (uncorrected width) of the striation. The opposite side is the actual, corrected striation breadth.

Differences calculated in the average striation breadth and variations in consistency of striation distances (expressed as average distance variances within individual tools), after and before correction for teeth per inch (TPI) of the inflicting tool, were compared between hand and mechanically powered saws. In order to evaluate whether the same tool leaves consistent patterns in striation distances or consistency, sets of different cutmarks inflicted with the same tool were also compared within both groups.

Phase 2: Inter-observer Error Study Based on Morphological Assessment

The aim of Phase 2 was to assess the accuracy of a visual determination of saw power using an inter-observer error study with inexperienced observers. In this case, the authors are testing the accuracy of determining saw power based on the examination and evaluation of the consistency of the cut, energy transfer, material waste, and minimum kerf width. Past research (Symes and Berryman 1989a; Symes 1992) has shown the value of separating hand powered from mechanically powered saws based on the first three characteristics (see **Sawmark Analysis Manual** in Part III of this report for a description of these characteristics). The authors determined the probability of correctly classifying toolmarks while also determining if specific saws or toolmarks were harder to classify or if correct classification was dependent upon the observer.

Phase 2 - Part A

A randomly generated sample of 20 bone sections was selected for use in Part A of Phase 2 (Table II-8). Only the cut surfaces with associated false starts were used in this portion of the study. Bone sections were labeled 1 to 20 in order to disassociate the saw number from the photographs that were viewed by observers. See Table II-9 for the specifications for the saws analyzed in Part A.

Table II-8. List of the bones sections selected for use in Part A of Phase 2.

Bone Section	Study Label	Hand/Power	Number of Photographs
16-126	1	Power	3
16-123	2	Power	5
18-120	3	Power	2
18-122	4	Power	5
5-121	5	Power	2
5-120	6	Power	6
17-120	8	Power	5
1-124	11	Power	4
1-119	12	Power	5
12-125	13	Power	4
17-121	16	Power	6
1-116	17	Power	4
12-119	20	Power	5
17-113	7	Hand	7
4-110	9	Hand	4
4-101	10	Hand	6
12-109	14	Hand	6
17-101	15	Hand	3
1-103	18	Hand	6
12-109	19	Hand	3

Table II-9. List of specifications for saws used in Part A.

Saw	Hand/Power	TPI	PPI	Set Type	Tooth Type	Direction of Cut	Blade (Saw) Name
101	Hand	11	12	ALT	CUT	P/P	Utility saw
103	Hand	8	9	ALT	CUT	P/P	Jab Saw
109	Hand	13	14	ALT	CUT	PULL	General Carpentry
110	Hand	15	16	ALT	CHISEL	PUSH	Back Saw
113	Hand	15	16	ALT	CHISEL	PUSH (PULL)	Coping Saw (Medium)
116	Power	140 teeth	---	ALT	CHISEL	PULL	Circular (Hollow Ground for: Plywood, Plastic, Laminates); 7 1/4 Diameter
119	Power	5	5/8	RAKER (7 th)	CHISEL	PULL	Reciprocating (Wood/Demolition)
120	Power	6	7	RAKER (7 th)	CHISEL	PULL	Reciprocating (Wood/Demolition)
121	Power	8	9	WAVE	CHISEL	PULL	Reciprocating (Demolition)
122	Power	14	15	RAKER (6 th)	CHISEL	PULL	Reciprocating (Metal Cutting)
123	Power	14	15	RAKER (3 rd)	CHISEL	PULL	Reciprocating (Metal Cutting)
124	Power	24	25	WAVE	CHISEL	PULL	Reciprocating (Fine) w/ Ryobi
125	Power	10	11	RAKER (3 rd)	CHISEL	PULL	Reciprocating (Medium) w/ Ryobi
126	Power	40 teeth		ALT	CHISEL	PULL	Circular (Fine Cutting) w/ Skilsaw; 7 1/4 Diameter

A negative impression was made of the cut surface of each bone section using *ForensicSil*. Bone sections were photographed from several different angles, including: an overall of the cut surface, an overall of the impression, the false starts, and the width of one false start with a scale. Figure II-10 depicts the photographs that were taken and, subsequently, viewed for Station 2. Observers were given between three and seven photographs to view per station (See Table II-8). The authors used information regarding the number of photographs to evaluate if there was an increase in accuracy with more information. The authors had expected that the accuracy would increase with additional photographs

The viewing order of the 20 stations was randomized for each individual taking part in this portion of the study. Observers were given their own data sheet with a randomly generated viewing order. This information was used to assess whether or not the observers' accuracies increased relative to more stations of photographs they viewed. The authors expected that the accuracy of correctly identifying hand and mechanically

powered saws would increase with each station, in other words more exposure, or as they became more experienced.

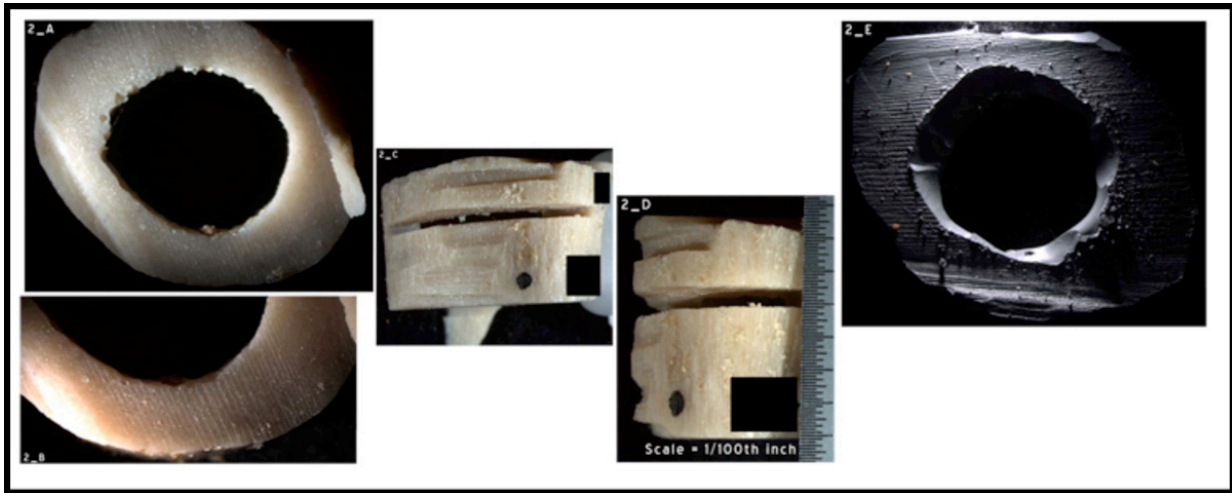

Figure II-10. The figure above is an example of images that observers viewed in order to make a visual assessment of saw power for each bone section.

Twelve individuals took part in Part A of the inter-observer error study. Prior to observation, subjects were introduced to the assessment of saw power based on morphological features of the cut surface and the false starts. A one-hour *PowerPoint* presentation was given to the group in order to introduce them to the basics of sawmark analysis and the visual evaluation of saw power.

Phase 2 - Part B

The purpose of Part B was to measure whether or not there was an increase in accuracy when more information was available to the observer. In this case, observers were able to view the actual bone sections. The authors also determined if more experience in determining saw power increases the accuracy for each observer.

Two randomly generated samples of ten bones sections (20 total) were selected for Part B of the inter-observer error study (Table II-10a and b). The label on each bone section was covered prior to observation (See Figure II-2 above). Table II-11 (a and b) highlights the specifications of the saws used in Part B. In this portion of the study, observers were able to look at the actual bone sections using a *Leica MZ A*

stereomicroscope and a *Keyence VHX-600* digital microscope. The viewing order for each observer was randomized for the first and second group of ten bone sections. The two groups of bone sections were viewed on two separate days.

Table II-10a and II-10b. (a) List of bone sections used for first group of ten bone sections in Part B. (b) List of bone sections used for second group of ten bone sections in Part B.

Bone Section	Study Label	Hand/Power
5-125	1	Power
5-121	2	Power
8-116	4	Power
5-124	5	Power
3-118	6	Power
7-126	8	Power
13-114	3	Hand
4-103	7	Hand
9-103	9	Hand
18-101	10	Hand

Table II-10a

Bone Section	Study Label	Hand/Power
16-122	11	Power
5-126	13	Power
19-120	14	Power
13-124	18	Power
11-120	20	Power
11-115	12	Hand
12-107	15	Hand
8-105	16	Hand
16-113	17	Hand
13-113	19	Hand

Table II-10b

Table II-11a and II-11b. (a) List of specifications for the saws used in Part B of Phase 2.

Saw	Hand/Power	TPI	PPI	Set Type	Tooth Type	Direction of Cut	Blade (Saw) Name
101	Hand	11	12	ALT	CUT	P/P	Utility saw
103	Hand	8	9	ALT	CUT	P/P	Jab Saw
114	Hand						
116	Power	140 teeth	---	ALT	CHISEL	PULL	Circular (Hollow Ground for: Plywood, Plastic, Laminates), 7 1/4 Diameter
118							
121	Power	8	9	WAVE	CHISEL	PULL	Reciprocating (Demolition)
124	Power	24	25	WAVE	CHISEL	PULL	Reciprocating (Fine) w/ Ryobi
125	Power	10	11	RAKER (3rd)	CHISEL	PULL	Reciprocating (Medium) w/ Ryobi
126	Power	40 teeth		ALT	CHISEL	PULL	Circular (Fine Cutting) w/ Skilsaw, 7 1/4 Diameter

Table II-11a

Saw	Hand/Power	TPI	PPI	Set Type	Tooth Type	Direction of Cut	Blade (Saw) Name
105	Hand	9	10	ALT	CHISEL	PUSH	Compass Saw
107	Hand						
113	Hand	15	16	ALT	CHISEL	PUSH (PULL)	Coping Saw (Medium)
115	Hand						
120	Power	6	7	RAKER (7th)	CHISEL	PULL	Reciprocating (Wood/Demolition)
122	Power	14	15	RAKER (6th)	CHISEL	PULL	Reciprocating (Metal Cutting)
124	Power	24	25	WAVE	CHISEL	PULL	Reciprocating (Fine) w/ Ryobi
126	Power	40 teeth		ALT	CHISEL	PULL	Circular (Fine Cutting) w/ Skilsaw, 7 1/4 Diameter

Table II-11b

Approximately one year later, 7 individuals from Part A participated in the inter-observer study in Part B. Prior to observation, the subjects were given access to the *PowerPoint* presentation that was presented to them in Part A.

Phase 2 Analyses

The accuracy of visually assessing saw power based on morphological features was tested. The authors were interested in determining if the subjects' accuracy increases with the number of photographs that they were allowed to view. The authors believed that this increase in information would potentially lead to an increase in accuracy. With this, the authors tested whether or not accuracy increases with the more stations of photographs that the observers view. In other words, are the observers gaining more experience and, therefore, increasing their accuracy in differentiating between hand and mechanically powered saws. Finally, the authors tested the accuracy of visual assessment with that of the metric analyses carried out in Phase 1.

Results from Phase 1

No significant differences in the relationship between striation breadth (distance) and TPI were found in an analysis of covariance (ANCOVA) between hand and mechanically powered saws ($F_{1,16} = 0.039$, $p = 0.847$ for the slope, and $F_{1,17} = 1.373$, $p = 0.257$ for the intercept; Figure II-11). Teeth Per Inch (TPI) does not correlate with striation breadth in the pooled sample ($p = 0.767$, Gaussian approximation, Figure II-12) or when both groups are considered independently ($F_{1,7} = 0.350$, $p = 0.572$ for hand, and $F_{1,9} = 1.644$, $p = 0.443$ for mechanically powered saws). This result is not an artifact derived from sample size, as the variance explained is marginal for all groups ($r^2_{\text{hand}} = 0.048$, $r^2_{\text{mechanic}} = 0.067$, $r^2_{\text{pooled}} = 0.005$). Therefore, as suspected, the distance between striations (striation distance) cannot be used to estimate the TPI of the inflicting tools.

Similar results were obtained when the raw distances between striations, without correction for TPI, were compared between both groups using a t-test with Welch correction for small sample size. Even when the striations inflicted by hand powered saws showed a slightly higher breadth ($12.6 \pm 8.72 \text{ mm } 10^{-3}$; 95% confidence interval; Figure II-13), this difference is not statistically significant ($t_{17} = 1.440$, $p = 0.084$, 1-tailed). However, as suggested by the low p-value obtained, power analysis suggests that a larger sample, with more than 30 individuals per group, may yield a different result.

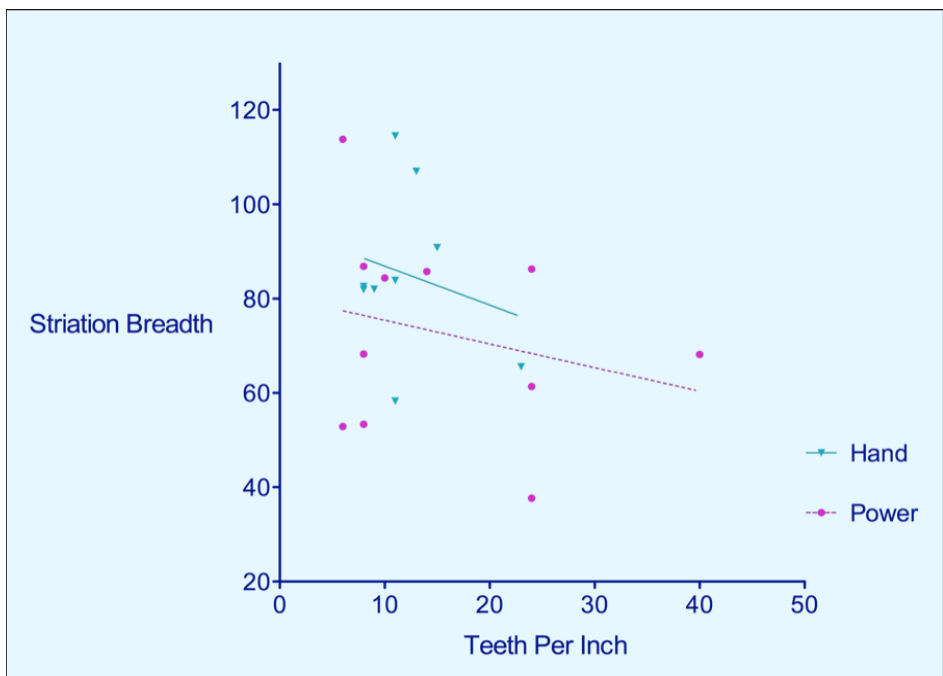

Figure II-11. No significant differences were found in the relationship between striation breadth and TPI in an analysis of covariance (ANCOVA) between hand and mechanically powered saws ($F_{1,16} = 0.039$, $p = 0.847$ for the slope, and $F_{1,17} = 1.373$, $p = 0.257$ for the intercept).

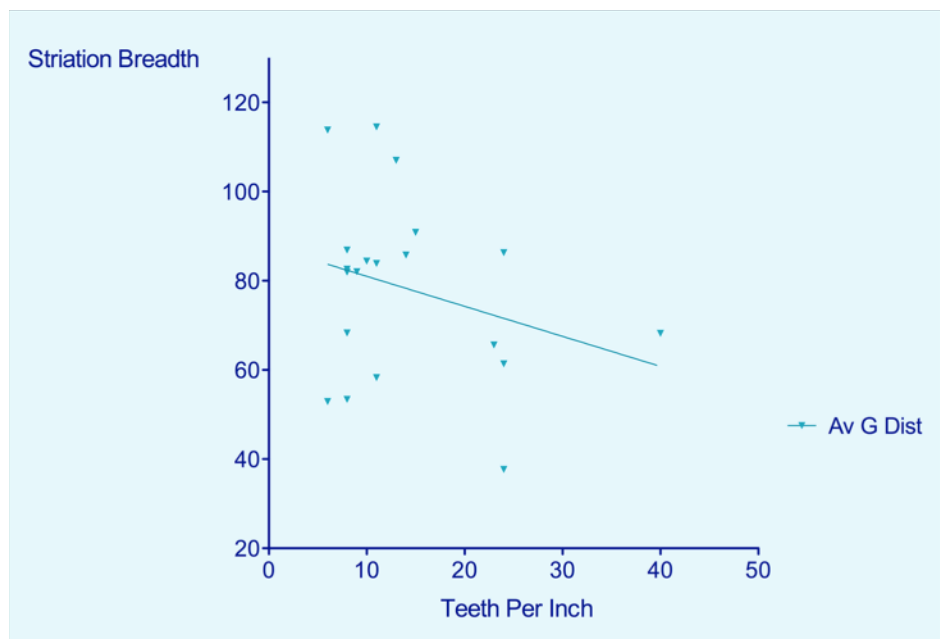

Figure II-12. This graph depicts the pooled sample of hand and mechanically powered saws comparing striation breadth and teeth per inch. TPI does not correlate with striation breadth either in the pooled sample or when both groups are considered independently. This result is not an artifact derived of sample size, because the variance explained is in any case marginal for all groups ($r^2_{hand} = 0.048$, $r^2_{mechanic} = 0.067$, $r^2_{pooled} = 0.005$).

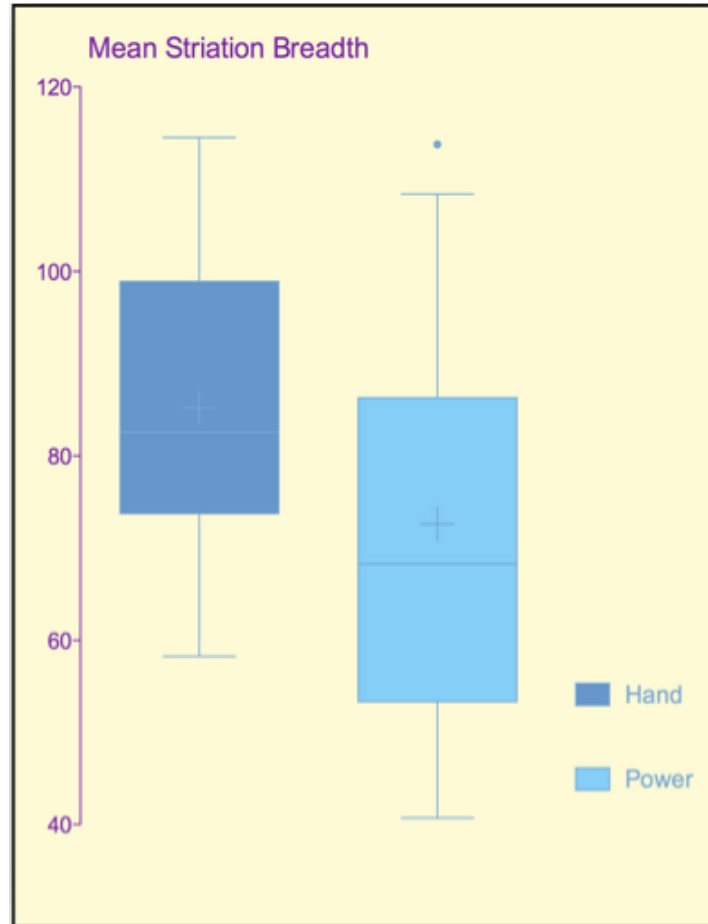

Figure II-13. This box and whisker plot depicts the mean striation breadth for hand and mechanically powered saws. Hand powered saws have a slightly higher mean striation breadth but this difference is not statistically significant.

More interestingly, the two groups do not seem to differ in their variances. This is evident when the group variances are compared through an F test ($F_{10,8} = 1.45$, $p = 0.611$) and, more relevant to this study, when the variances within individual tool marks (i.e. consistency, as defined above) are compared through a non-parametric test (Mann-Whitney U; $p = 0.483$, Gaussian approximation; Figure II-14). Therefore, the diagnostic visual differences in striation consistency do not seem to translate metrically to an extent allowing for easy metric discrimination between hand and mechanically powered saws.

The lack of correlation between TPI and striation breadth, striation breadth and the type of saw (hand vs. mechanical), and the difficulty of measuring striation consistency are likely related to the influence of confounding variables not associated with the tool itself.

In this way, striation breadth would be more influenced by the characteristics of the bone, the person operating the tool, his or her positioning during the operation, etc. In order to illustrate these elements, three different saw marks, inflicted by the same individual (ENC) with the same tool, (hand saw 121; Table II-12; Figure II-15), but on different bone sections, were compared for average striation breadth through an ANOVA design. In this analysis, not only were significant group differences found ($F_{2,19} = 229$, $p < 0.001$; Figure II-15), but a post-hoc Bonferroni test revealed that all three cut marks differed from each another at the 0.05 level. Consequently, average striation breadths (striation distances) are not consistent within tools, and depend more on extrinsic factors. However, the variances of the three cut marks did not differ ($F_{4,3} = 1.286$, $p = 0.871$), suggesting that the consistency of striation distances may be more constant within individual saws and may be a potential implement to assess some of their characteristics.

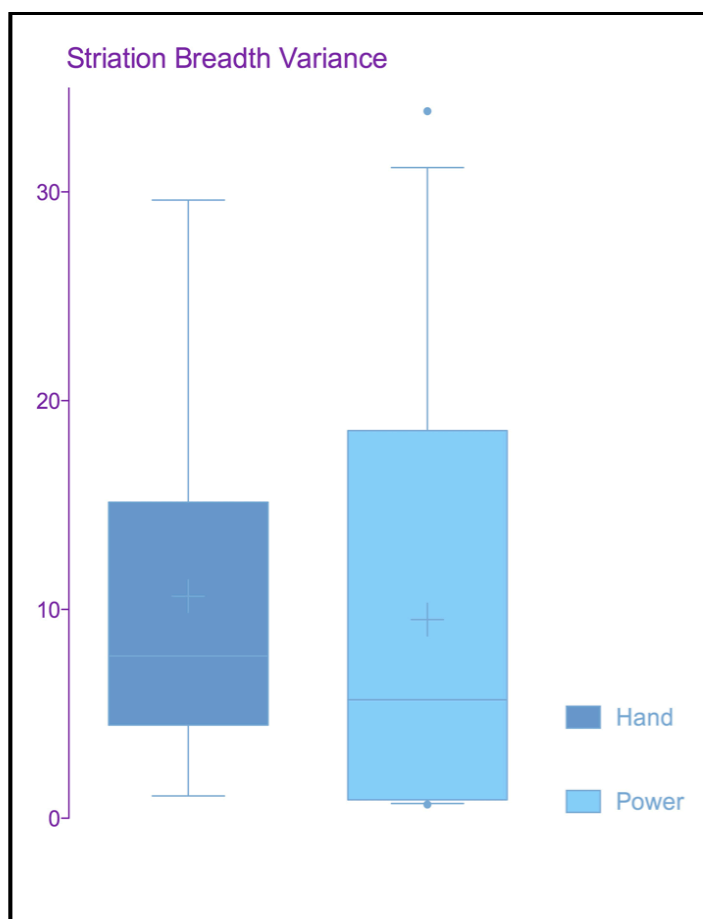

Figure II-14. This box and whisker plot shows that there is no significant difference in group variance between mechanically and hand powered saws when using a Mann-Whitney t-test of variance.

Table II-12. This table lists the striation breadth measurements obtained for the three different bone sections that were cut with saw 121.

121 A	121 B	121 C
70.66155	91.56482	48.07609
65.76013	86.55778	51.64774
68.80083	87.63197	57.24311
68.7305	87.61406	56.48388
68.45731	83.86951	
71.48063	86.99848	
69.12322	83.54118	
63.40777	87.83074	
	85.39248	
	87.64083	

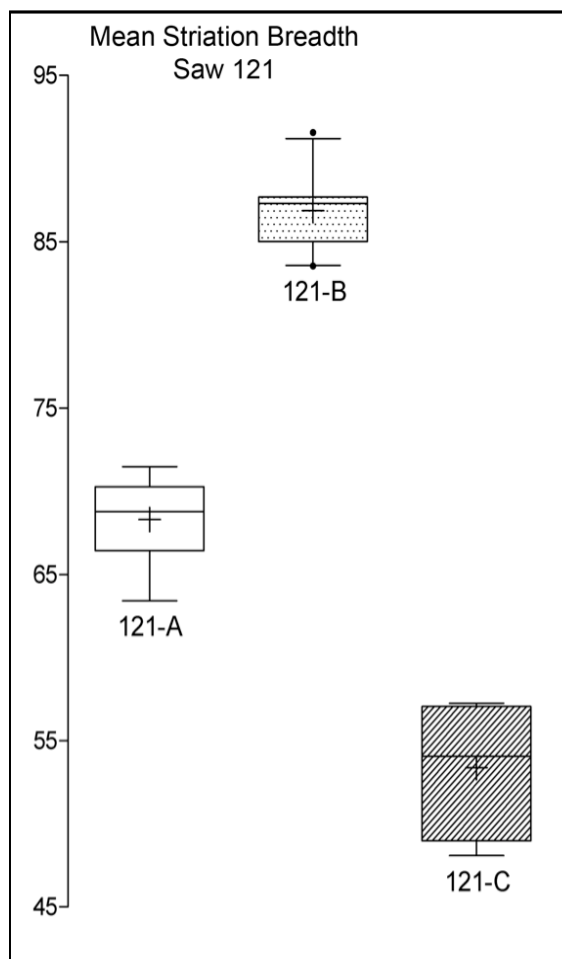

Figure II-15. This box and whisker plot depicts the significant group differences in mean striation breadth that were found between the three cutmarks using an ANOVA test.

Results from Phase 2

In Part A of the inter-observer error study, a 71.25% correction classification (65.5% to 77.0%, 95% confidence interval) was obtained for the twelve individuals that participated. The authors found no correlation (Spearman's $r = 0.024$ with a 95% confidence interval of -0.435 to 0.472; $p = 0.921$, Gaussian approximation) between correct classification and the number of photographs that the observers were able to view. Additional photographic information does not appear to have an effect on the observer's ability to correctly classify (Figure II-16).

In Part B of the inter-observer error study, a 69.28% correct classification (62.39% to 74.17%, 95% confidence interval) was obtained for the seven individuals for Part A that also participated in Part B. The authors wanted to determine if the two samples could be

pooled because overall correct classification was similar for the first and second session. It was necessary to first determine if correct classification was independent of the observers since seven observers participated in both sessions. If correct classification was not dependent upon the observers themselves and there were no significant differences in correct classification from the first session to the second session then the two samples could be pooled.

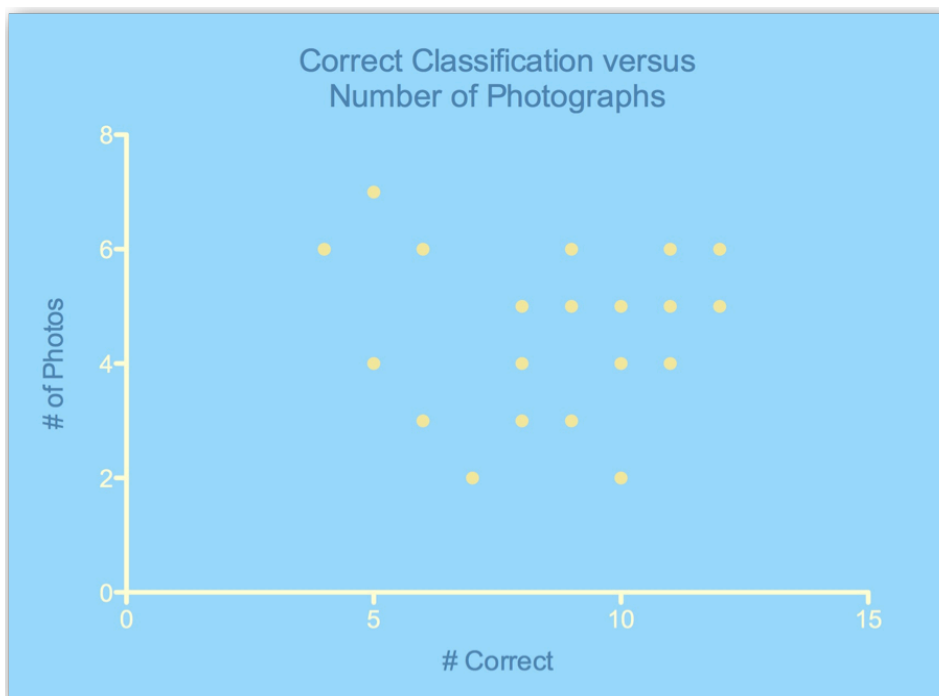

Figure II-16. Using a Spearman's r test the authors found that there is no correlation between correct classification and the number of photographs that were observed.

Using a Fisher's exact test ($p= 0.727$, two-sided), no significant differences were found in overall correct classification from session one to session two, (Figure II-17). The authors then tested if there were significant differences in correct classification for each observer from session one to session two. No significant differences were found using a Chi-square test ($\chi^2_{df=6} = 1.423$; $p= 0.964$) (Figure II-18). No significant differences were found in correct classification from session one to session two using a Spearman's r correlation (Spearman's $r = -.0457$; $p = 0.302$, exact) to test whether correct classification was dependent upon ability of the observers (Figure II-19). Therefore, correct classification did not increase with more experience or seem to be correlated with personal ability in correctly classifying.

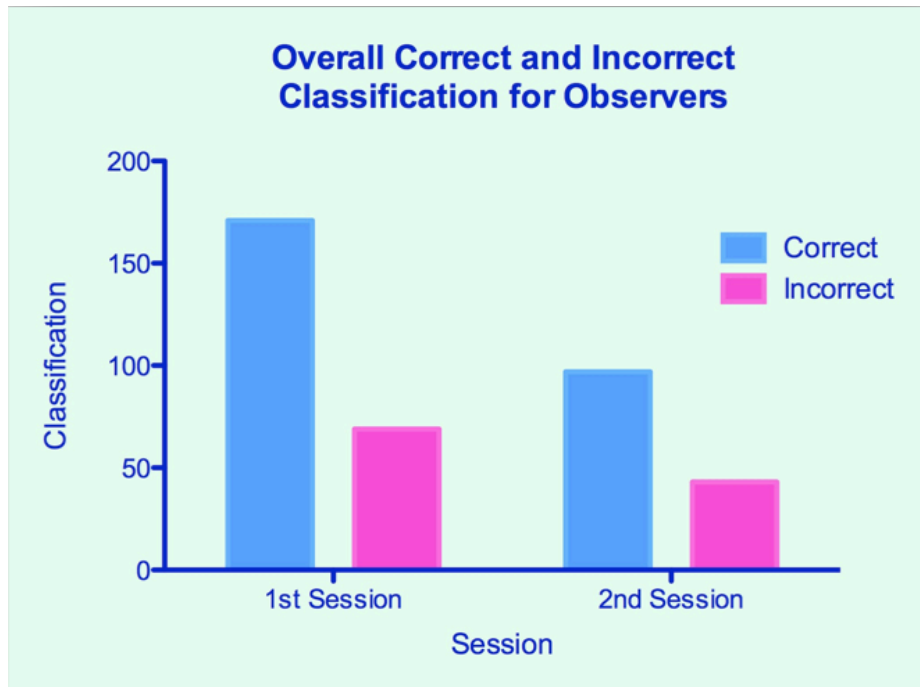

Figure II-17. This bar graph illustrates that there is no significant difference between correct classifications from Session One to Session Two using a Fisher's exact test.

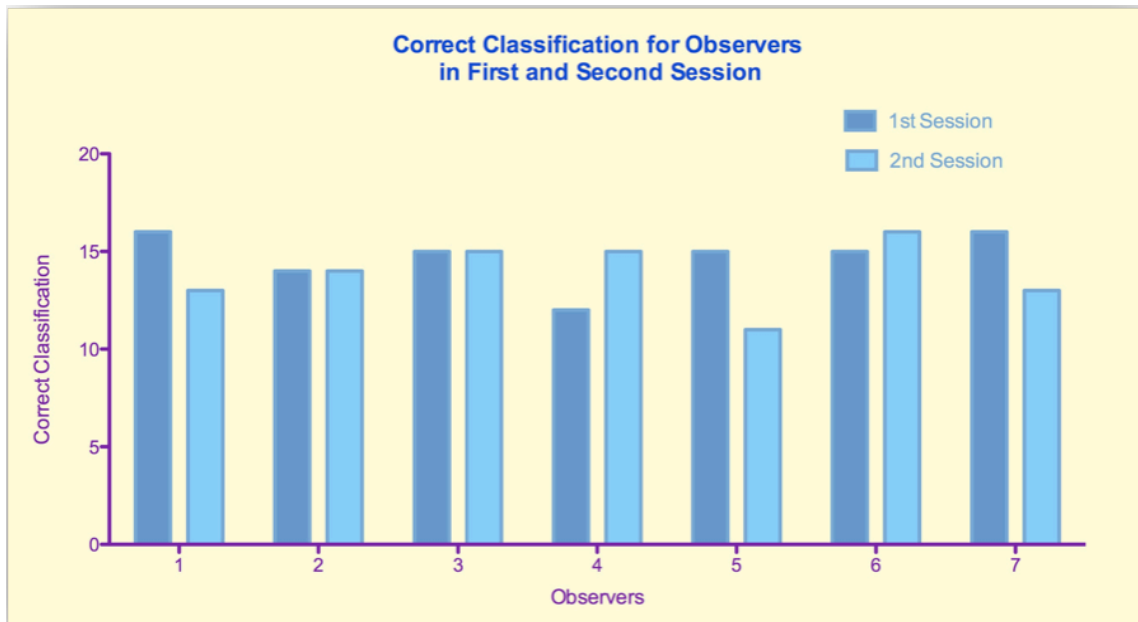

Figure II-18. Using a Chi-square test the authors compared correct classification in Session One and Session Two for each individual observer. There was no significant difference found among correct classifications for each observer from Session One to Session Two.

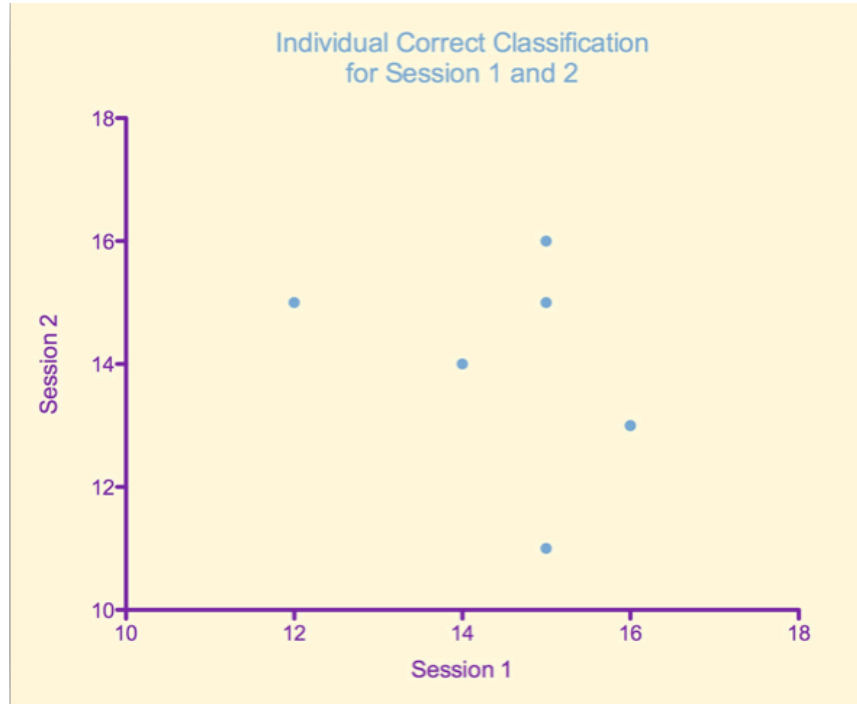

Figure II-19. Using a Spearman's r correlation test the authors found that there was no significant difference in correct classification from Session One to Session Two. Correct classification did not increase with more experience or appear to be correlated with the observers' ability.

Based on the knowledge that: 1) there was no significant difference found in correct classification from session one to session two and 2) correct classification seems to be independent of the observer when observations from part A and B were pooled, the authors determined that there was 70.5% correct classification (65.9% to 75.1%, 95% confidence interval) when observations from session one and two were pooled.

The authors had to determine whether the 70.5% pooled classification is significantly different from that of random chance. Using a Chi-square test ($\chi^2_{df=1} = 62.80$; $p = <0.0001$; two-sided), there was a significant difference in correct classification for hand and mechanically powered saws (Figure II-20).

In order to determine the probability of correctly classifying a toolmark from that of random chance a Sensitivity and Specificity test was employed. Sensitivity, in this case, referred to the fraction of hand-powered saws classified as hand powered saws. The sensitivity calculated was 0.721. In other words the correct classification for hand-powered saws was 72.1% (64.1% to 79.2% correct classification with a 95% probability).

Specificity, referred to mechanically powered saws and represented the fraction of mechanically powered saws classified as mechanically powered saws. This was calculated to be 0.696. The correct classification for mechanically powered saws was 69.6% (63.2% to 75.4% correct classification with a 95% probability). The probability of correctly classifying a toolmark was significantly different from that of random chance ($\chi^2_{df=1}=62.80$; $p<0.0001$).

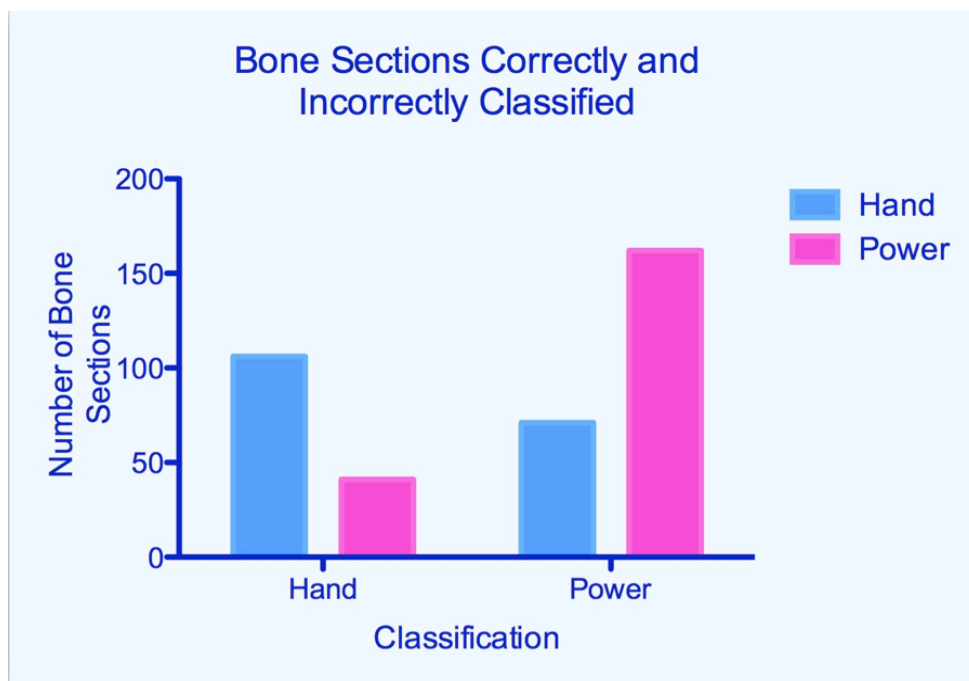

Figure II-20. This graph depicts the number of hand and mechanically powered saws classified correctly and incorrectly plotted against the number of bone sections that were observed for each type of saw. Using a Chi-square the authors concluded that the 70% correct classification that was obtained was significant from that of random choice.

The likelihood ratio for hand and mechanically powered saws was calculated in order to determine the likelihood of a toolmark being classified as a type of tool and the toolmark was created by that type of tool. A toolmark identified as being inflicted by a hand powered saw is 2.37 times more likely to have actually been created by a hand powered saw than a mechanically powered saw. A toolmark identified as being caused by a mechanically powered saw is 2.49 times more likely to have actually been created by a mechanically powered saw than a hand powered saw. The larger ratio for mechanically powered saws was a product of the sample size being larger for mechanically powered saws. The calculated likelihood ratios are equivalent to the posterior probability.

There are significant differences in correct classification between specific saws. Using a Chi-square significance test ($\chi^2_{df=18} = 60.65$; $p < 0.0001$), the authors evaluated correct and incorrect classification separated by the nineteen saws that were used in Phase 2 (Figure II-21). Based on the results of this test, some saws were harder to correctly classify than others. Using a Spearman's r test (Spearman's $r = 0.832$, between 0.598 and 0.935 with a 95% confidence interval; $p = < 0.0001$, Gaussian approximation), the authors looked at the correlation between correct classification and total number of observations for each saw. There was a correlation between saw and correct classification (Figure II-22). An increase in variation of the saw operator (speed of blade movement, weight applied to the saw, skill of operator, etc.) inherent in hand powered saws (103, 113, and 115) may explain why hand powered saws are the hardest and easiest saws to classify.

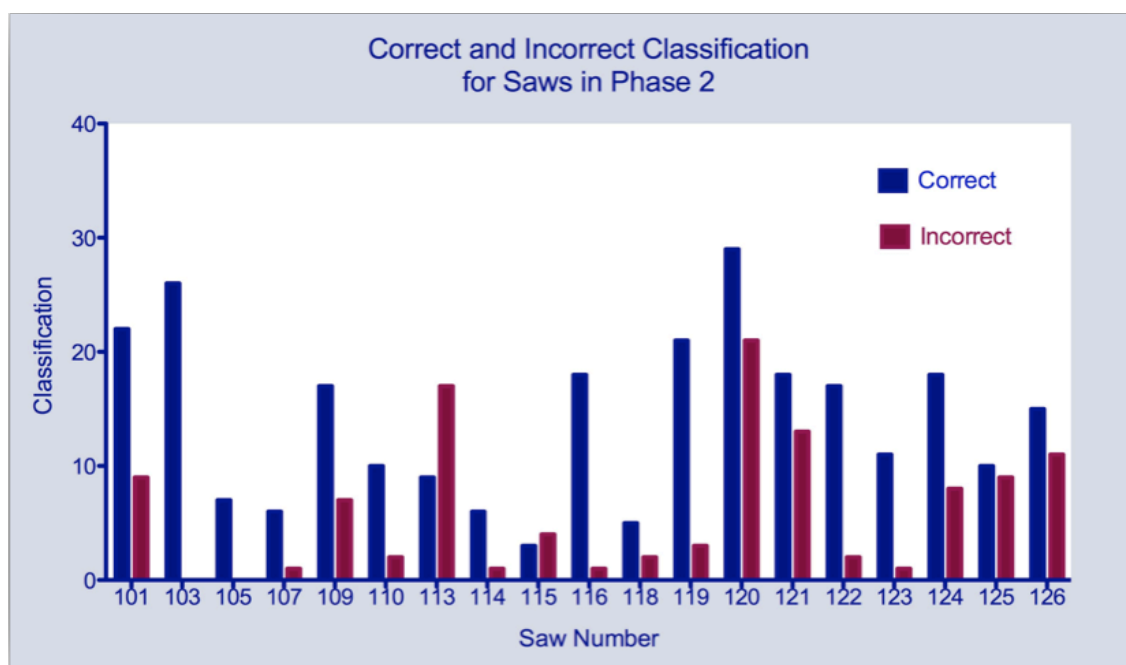

Figure II-21. This graph depicts correct and incorrect classification for each of the 19 saws observed in the study in order to determine if some saws are harder to correctly classify than others. Using a Chi-square test the authors found a significant difference in correct classification between specific saws. Saw 103 appears to be the easiest to classify while Saws 113 and 115 appear to be the most difficult to correctly classify.

There are significant differences in correct classification between bones ($\chi^2_{df=13} = 48.16$; $p = < 0.0001$). Specific bones were easier and harder to classify than others (Figure II-23). In this study, the humeri were harder to classify than the femora. This may be due to extrinsic factors such as: skeletal element, cortical bone thickness, or effects of processing and cleaning.

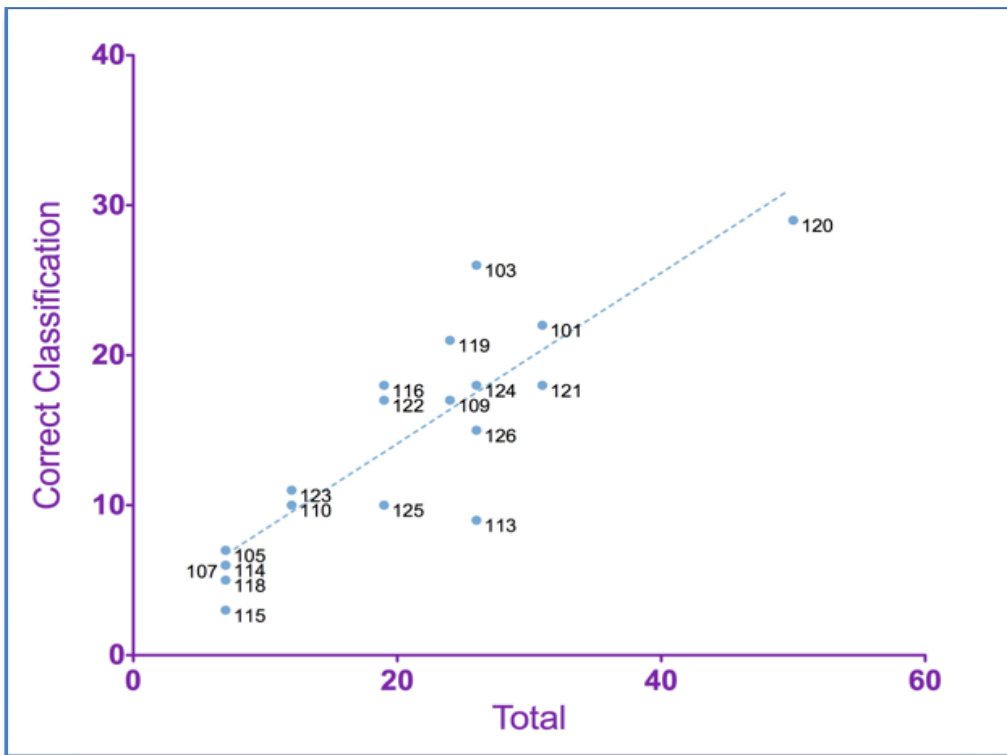

Figure II-22. This regression plot compares the number of correct classifications for each saw against the total number of observations for each saw. Using a Spearman's r the authors found a correlation between correct classification and the total number of observations.

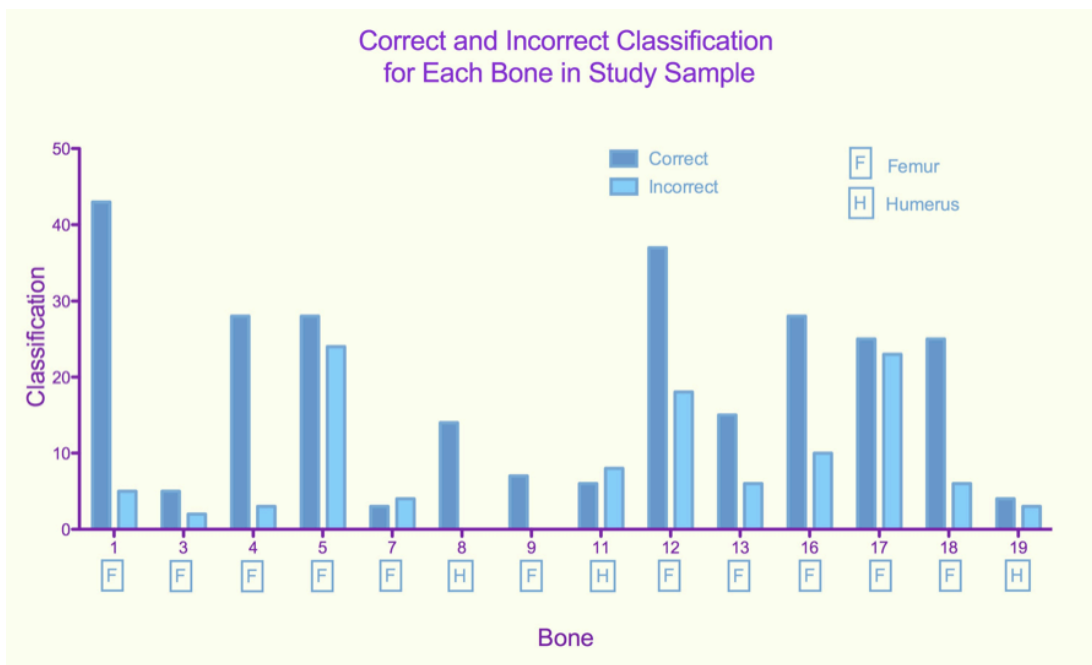

Figure II-23. This graph depicts correct and incorrect classification for each of the 19 bones used in the study. Using a Chi-square test, significant differences were found in correct classification between bones.

Discussion

Phase 1: Metric Analyses

Based on information gleaned from the analysis of Phase 1, the authors concluded that striation breadth could not be used to estimate class characteristics of the inflicting tool, even at the hand versus power level. Striation metric characteristics seem to depend more heavily on extrinsic factors rather than the tool. As seen in the analysis of three cutmarks created by the same saw, the same operator produces different marks with the same saw and under similar conditions. Observed consistency of distance between striations may be more constant within individual saws. The authors feel confident that reliable, straightforward metric discrimination between hand and mechanically powered saws is unlikely to be possible.

Phase 2: Visual Assessment

A 70.5% correct classification (65.9% - 75.1%, 95% confidence interval) was attained for inexperienced observers. This accuracy in correct classification was obtained with very little information being available to the observers. At most, the observers were given the opportunity to view one cut surface and a few false starts for each observation. The authors expect that correct classification would be higher for experienced saw mark analysts. Often times, in cases of dismemberment, toolmark analysts have access to more than one cut surface, usually amounting to a number of cut surfaces from multiple dismembered limbs. The authors also expect that correct classification will increase with the addition of more cut surfaces and false starts.

Based on the information gathered in Phase 2, hand and mechanically powered saws are nearly equal in the probability of correct classification with neither being harder to classify. As expected, there were specific saws that were more difficult to classify than others. Some bones in the sample were also more difficult to classify correctly. In this study femora were easier to classify than humeri. Difficulty in correctly classifying specific bones is likely due to factors such as: cortical bone thickness, skeletal element, or product of processing (i.e., greasy, over cooked).

Unexpectedly, correct classification did not correlate to specific observers abilities, at low levels of training. It is important to point out that this observation only pertains to inexperienced trauma analysts. The authors still expect that for individuals with much

higher levels of experience, accuracy will correlate to their ability to recognize patterns on the cut surfaces.

Frequency of Traits and Characteristics Related to Saw Power

Introduction

By accessing the presence or absence of particular sawmark class characteristics, the ability to narrow potential saws may be significantly increased. As previously stated, in a time of strict Daubert standards, the ability to produce and replicate reliable scientific analysis is imperative. This study was designed to assess the presence and absence of specific sawmark characteristics (Table II-13; Appendix II-D). The aim of this portion of the project is to use the frequency of traits to determine if specific types of saws more often create specific traits. The authors used this information to assess the frequency of specific traits in hand and mechanically powered saws.

Table II-13. This table lists the traits and characteristics used to assess frequency in the cut bone sections.

Entrance Shaving	Material Waste	Polish	Curved KF Contour	Flat KF Contour	Bone Islands	Tooth Hop	Consistency of Cut	Pat Striae Shuffle	BA-Spurs
Cut Surf Drift	Pull Out Striae	Kerf Flare	Blade Drift	Energy Transfer	BA-Notch	Exit Chipping	Harmonics	Tooth Imprint	FI Dip

Sample

A randomly generated sample of ten bone sections was selected from the study sample for a pilot study. A database was created for coding the features and traits using an *Excel* spreadsheet. Using a *Leica MZ 16 A* stereomicroscope each bone section was viewed microscopically and coded for the presence and absence of each trait.

The authors determined that a larger sample size was necessary to assess the frequency of traits and features evident on the cut bone sections. Forty randomly generated bone sections were selected in order to attempt to meet the requirements of statistically significant sample size. Two bone sections that were selected were being used in another portion of the project and therefore were omitted from analysis. A total of thirty-eight bone sections were analyzed after the pilot study. After the sample was generated, each bone was subjected to trait coding using a *Lecia MZ A* stereomicroscope.

The data set were then divided into two tables, one being cutmarks produced from handsaws and the other being cutmarks produced by mechanically powered saws and the frequency of occurrence of the traits and features was compared. The two groups of saws (hand and mechanically powered) were further divided by set (alternate, wavy, raker) and tooth shape (cut, chisel). After a comparison was made between the sample sizes of hand and mechanically powered saws, the authors decided to make the samples even. The initial sample set contained twenty-five bone sections cut with hand powered saws and thirteen bone sections cut with mechanically powered saws. An additional twelve bones sections cut with mechanically powered saws were selected and coded in order to make the two samples even.

Trait Coding

The analysis of each bone consisted of indicating the presence or absence of all traits and characteristics by assigning either a "0" to indicate the absence of a trait or feature or a "1" to indicate the presence of a trait or feature (Appendix II-D). In the case of the presence or absence of false starts, it should be noted that the entire sample had the presence of false starts, since they were purposefully created when the cutmarks were being made on the bones. While the presence of the false starts was recorded as already described, another section was created to account for the number of false starts in which a number was recorded for each bone section.

After the presence and absence of all traits and features was completed, information was entered into a spreadsheet. Once all of the data was entered into the spreadsheet, the information about the set shape and power of the saw used to create each cutmark was discovered and included into the data set. Once this was accomplished, the frequency of occurrence of each trait and feature was calculated.

Results

The frequency of each trait observed in the total sample set of 50 sawmarks was calculated by dividing the total number of samples by the number of times the trait was observed (Table II-14). Each trait and/or characteristic was subjected to a chi square test. This was achieved by first calculating the observed and expected results (Table II-14). The expected results were calculated by multiplying the frequency of the trait observed in the total sample by the number of samples in each individual set of

sawmarks created by hand and power saws (Table II-14). There were twenty-five samples in each sample set, so the expected results were the same for each sample set. Thus the null hypothesis of the chi-square analysis is that sawmarks created by hand and power saws look/present the same traits/characteristics and so have the same frequency of traits/characteristics.

After calculating the expected results a chi-square value for each trait in both sample sets was determined using the formula: $(\text{observed}-\text{expected})^2/\text{expected}$ (Table II-14). To determine the final chi-square value, the chi-square value calculated for a particular trait in both the hand and power samples sets were added together (Table II-14).

Table II-14. Frequency and chi-square analysis of sawmark traits/characteristics

Saw Trait	Total Frequency of trait	Expected	Power Observed	Hand Observed	Power Chi-square	Hand Chi-square	Final Chi-square
Kerf flare	0.02	0.5	0	1	0.5	0.5	1
Exit Chipping	0.88	22	25	22	0.409091	0	0.409090909
Entrance Shaving	0.5	12.5	11	14	0.18	0.18	0.36
Bone Islands	0.08	2	1	3	0.5	0.5	1
BA-spur	0.84	21	21	21	0	0	0
BA-notch	0.18	4.5	3	6	0.5	0.5	1
Blade drift	0.56	14	8	20	2.571429	2.571428571	5.142857143
Harmonics	0.5	12.5	10	15	0.5	0.5	1
Flat KF Cont.	1	25	25	25	0	0	0
Curved KF Cont.	0	0	0	0	0	0	0
Consistency of Cut	0.42	10.5	14	7	1.166667	1.166666667	2.333333333
Cut Surface Drift	0.4	10	7	13	0.9	0.9	1.8
Energy Transfer	0.36	9	10	8	0.111111	0.111111111	0.222222222
Material Waste	0.56	14	17	11	0.642857	0.642857143	1.285714286
Polish	0.88	22	24	20	0.181818	0.181818182	0.363636364
Tooth Hop	0.16	4	4	4	0	0	0
Pull Out Striae	0.16	4	2	6	1	1	2
Tooth Imprint/Fl dip	0.08	2	2	2	0	0	0
False Starts	1	25	25	25	0	0	0

Before calculating a p-value for each trait/characteristic, some traits were excluded from the study. False starts were eliminated due to the fact that they were deliberately cut

into each bone; similarly break-away spurs were eliminated because they were present in every sample resulting in a chi-square value of zero. Both flat and curved kerf floor contours were eliminated, since they are dependent upon the shape of a saw. Energy transfer and material waste were also deleted from the list of traits/characteristics because of their subjective nature and illusive definition.

After achieving a chi-square value, p-values were calculated for each trait/characteristic using a standard chi-square distribution (Table II-15). Only blade drift trait had a chi-square value above the 3.8415 critical value and a p-value below .05 (Table II-15). Blade drift is observed more often in sawmarks created with a hand saw, and is the only trait/characteristic that was found to have statistical relevance when looking at a sawmark.

Table II-15: results of chi-square analysis after certain traits were eliminated

Saw Trait	Total Frequency of trait	Expected	Power Observed	Hand Observed	Power chi-square	Hand chi-square	Final chi-square	p-value
Exit Chipping	0.88	22	25	22	0.409091	0	0.409090909	0.522
Entrance Shaving	0.5	12.5	11	14	0.18	0.18	0.36	0.549
Bone Islands	0.08	2	1	3	0.5	0.5	1	0.317
BA-notch	0.18	4.5	3	6	0.5	0.5	1	0.317
Blade drift	0.56	14	8	20	2.571429	2.571428571	5.142857143	0.023
Harmonics	0.5	12.5	10	15	0.5	0.5	1	0.317
Consistency of Cut	0.42	10.5	14	7	1.166667	1.166666667	2.333333333	0.127
Cut Surface Drift	0.4	10	7	13	0.9	0.9	1.8	0.180
Polish	0.88	22	24	20	0.181818	0.181818182	0.363636364	0.546
Pull Out Striae	0.16	4	2	6	1	1	2	0.157

After the chi-square results yielded only one trait of statistical relevance, a G-power analysis was run for each trait/characteristic to determine how large a sample size would be needed to detect a statistical difference in the appearance of certain traits present in the sawmarks created by hand v. power saws. The G-power test was done using *GPower 3.1.2* software program (2010) by setting the program to chi-square test family and using a goodness of fit statistical test and a priori power test.

After running the power analysis the sample sizes determined to show statistical relevance in determining hand v. power saws for each trait (Table II-16), the sample

sizes were seen to be quite large, the smallest sample sizes needed was 253 for consistency of cut. The largest sample size required was 3,091 for bone islands.

Table II-16. Frequency results, including sample sizes, using G-power.

Trait	Frequency in Hand	Frequency in Power	Sample size
Exit Chipping	0.88	1	1,374
Entrance Shaving	0.56	0.44	1374
Bone Islands	0.12	0.04	3091
BA-notch	0.24	0.12	1374
Harmonics	0.6	0.4	495
Consistency of Cut	0.28	0.56	253
Cut Surface Drift	0.52	0.28	344
Polish	0.8	0.96	773
Pull Out Striae	0.24	0.08	773

PART III: PRODUCTS OF NIJ FUNDING

NIJ Research Milestones

The table below (Table III-1) summarizes the dissemination accomplishments of the NIJ funding. The milestones are categorized by the stages listed in the original proposal of this project.

Table III-1. NIJ research milestones with dissemination categorized into stages.

Date	Stage	Accomplishment
9/16/2005		Introduced the new project funded by the NIJ
10/29/2005	2	Invited lecturer, Michigan Association of Medical Examiners: <i>Potential of trauma and toolmark analysis</i> . East Lansing, MI.
11/5/2005	1	NIJ General Forensics TWG. Washington, DC.
11/5-6/2005	1	Papers presented, North East Forensic Anthropology Association: Justification of toolmark analysis in bone. College Park, MD.
1/15/2006	Other	Lucas Research Grant awarded, Forensic Sciences Foundation of the American Academy of Forensic Sciences: <i>A Reassessment of Human Skeletal Trauma Molding and Casting Methodologies: Preserving Evidence</i> . Steven A. Symes, PhD, DABFA (Principle Investigator)
2/23/2006	1	Presentation, Annual meeting of the American Academy of Forensic Sciences: <i>Anthropological Sawmark Analysis on Bone: What is the Potential of Dismemberment Interpretation?</i> Seattle, WA.
3/25/2006	2	Training session, Law Enforcement Innovation Center at the National Forensic Academy. One week training session for 40 FBI Evidence Response Team members. Knoxville, TN.
5/30/31/2006	2	Presentation, Ontario Fire Marshall's Office and York Regional, and Toronto Police Departments. Two-day presentation. New Market, Ontario.
6/3-5/2006	1	Presentation, International Association of Identification: <i>Toolmark Analysis on Bone: Identifying Class Characteristics</i> . Boston, MA.
6/3-5/2006	2	Presentation, National Institute of Justice Awardees meeting at the annual meeting of the International Association of Identification. Boston, MA.
6/7/2006	1	Cover article, Forensic Magazine, June & July 2006: <i>A Cut Above: Sharpening the Accuracy of Knife and Sawmark Analysis</i> by Deborah W. Morton. Article describing NIJ sawmark research grant.
6/14/2006	2	Workshops and courses, annual meeting of the Armed Forces Institute of Pathology and National Transportation Safety Board. Courses in Forensic Anthropology. Washington, DC.
6/20-21/2006	2	Seminar, Lancaster and Dauphin County Police Departments. Lancaster, PA.

6/19-23/2006	2	Short course instructor, 3rd annual Analysis of Bone Trauma and Pseudo-Trauma in Suspected Violent Deaths at Mercyhurst College. Erie, PA.
7/31-8/4/2006	2	Invited lecturer, University of Tennessee Short Course: traumatized bone and specifically sharp trauma/toolmarks. Knoxville, TN.
11/16/2008	3	Presentation & workshop, Bureau of Criminal Apprehension at the Minnesota State Crime Laboratory: <i>Knife and Saw Toolmark Analysis in Bone: Research Designed for the Examination and Interpretation of Criminal Mutilation and Dismemberment</i> . All state firearms and toolmark examiners were present. St. Paul, MN.
11/18/2006	2	Guest lecturer, Minnesota/St. Paul Metro area Medical Examiners. Toolmark methodologies and NIJ sawmark analysis grant. St. Paul, MN.
12/15/2006	3	Workshop, FBI toolmark and firearms personnel at the FBI Headquarters: <i>Knife and Saw Toolmark Analysis in Bone: Research Designed for the Examination and Interpretation of Criminal Mutilation and Dismemberment</i> . Quantico, VA.
12/15/2006	1,3	Seminar, FBI toolmarks and firearms section at the FBI Headquarters: <i>Anthropological Analysis of Saw marks: What is the Potential of Dismemberment Interpretation?</i> Quantico, VA.
1/26/2007	2	Workshop and presentation, Anthropology Department at Michigan State University: sawmark analysis. East Lansing, MI.
2/6/2007	3	Seminar instructor, Law Enforcement Innovation Center at the National Forensic Academy. One-day training seminar on bone trauma. Knoxville, TN.
2/19-24/2007	1	Presentation, American Academy of Forensic Sciences: <i>Standardizing Saw and Knife Mark Analysis on Bone</i> . San Antonio, TX.
4/2/2007	2	Presentation, New York State Association of County Coroners and Medical Examiners
4/23/2007	2	Presentation, New York City Medical Examiner's Office: skeletal trauma and specifically sawmark analysis in bone. New York, NY.
4/24/2007	2	Presentation, Anthropology Department at New York University: skeletal trauma. New York, NY
5/6/2007	2	Guest lecturer, Medicolegal Investigation of Death Conference: <i>Anthropological Analysis of Trauma: What the Bones Can Tell Us</i> . Dearborn, MI.

5/7/2008	2	Guest lecturer, Guilford College: skeletal trauma. Christopher W. Rainwater and Nicolas V. Passalacqua. Greensboro, NC.
5/27-6/1/2007	3	Workshop, Association of Firearms and Toolmark Examiners, annual training seminar. San Francisco, CA.
6/14/2007	2	Presentation and Workshop, annual meeting of the Armed Forces Institute of Pathology and National Transportation Safety Board. Courses in Forensic Anthropology. Washington, DC.
6/18-22/2007	2	Short course instructor, 4th annual Analysis of Bone Trauma and Pseudo-Trauma in Suspected Violent Deaths at Mercyhurst College. Erie, PA.
7/2/2007	3	Seminar instructor, Law Enforcement Innovation Center at the National Forensic Academy. One-day training seminar on bone trauma. Knoxville, TN.
7/7-12/2007	2	Presentation, Forensic Anthropology Conference of Europe held at the University of Coimbra. Coimbra, Portugal.
9/1-30/2007	Other	One month training for microscopic analysis of toolmarks on bone and bone trauma for Claudia Garrido from the Institute of Legal Medicine. Santiago, Chile.
10/2-3/2007	2	Presentation, Minnesota Forensic Science Seminar 24th annual meeting: <i>Bone Trauma in a Medical Examiners Setting: Recognizing Forensic Toolmarks and Fracture Patterns in Bone</i> . Minneapolis, MN.
10/12-17/2007	1	Presentation, National Association of Medical Examiners annual meeting: <i>Sawmark Analysis On Human Bone: A Problematic yet Revealing Dismemberment Interpretation</i> . Savannah, GA.
10/22-23/2007	3	Seminar instructor, Law Enforcement Innovation Center at the National Forensic Academy. Two-day training seminar on bone trauma. Knoxville, TN.
1/23-27/2008	2	Invited speaker, Mayborn Museum Complex at Baylor University for their January lecture series and round table discussions. Waco, TX.
2/11/2008	3	Seminar instructor, Law Enforcement Innovation Center at the National Forensic Academy. One-day training seminar on bone trauma. Knoxville, TN.
2/18-23/2008	1	Special session workshop, 60th annual meeting of the American Academy of Forensic Sciences: <i>Analysis and Interpretation of the Suitcase Murder Case: the Prosecution of a Dismemberment Case that Covered Two State Jurisdictions</i> . Washington, DC.

2/18-23/2008	1	Presentation, 60th annual meeting of the American Academy of Forensic Sciences: <i>Recognizing Patterned Fire and Heat Damage to Bone</i> . Washington, DC.
2/18-23/2008	1	Presentation, 60th annual meeting of the American Academy of Forensic Sciences: <i>How easily can we derive cause and manner of death on the basis of dry bones? Lessons derived from Coimbra identified skeletal collections</i> . DCE Cunha, JV Badal, A Lyrio, J Pinheiro, and SA Symes. Washington, DC.
2/18-23/2008	1	Presentation, 60th annual meeting of the American Academy of Forensic Sciences: Cranial bone trauma: misleading injuries. J Pinheiro, A Lyrio, E Cunha, and SA Symes. Washington, DC.
2/19/2008	2	Presentation, General Forensics R & D Grantees Meeting of the National Institute of Justice, Office of Science and Technology, Investigative and Forensic Science Division: <i>Sawmark Dismemberment: Simply Another Tool</i> . Held in conjunction with the AAFS annual meeting. Washington, DC.
3/18-20/2008	2	Invited lecturer, Breakout session <i>Unique Forensic Technologies and Techniques</i> for the 2008 National Institute of Justice Applied Technologies Conference. Point Clear, AL.
5/8-10/2008	2	Invited lecturer, University of Pretoria. Lectures given on bone trauma analysis and sharp force trauma. Pretoria, South Africa.
5/11-17/2008	2	Presentations (two), presented to local anthropology classes and international human rights workers at the University of Cape Town. Presentations given on bone trauma analysis. Cape Town, South Africa.
6/11/2008	2,3	Invited guest lecturer and workshop, 21st annual Forensic Anthropology Conferences sponsored by the Armed Forces Institute of Pathology, held at the National Transportation and Safety Board. Lecture and workshop given on bone trauma analysis. Ashburn, VA.
6/16-20/2008	3	Short course, <i>5th Annual Short Course on Traumatized Bone</i> at Mercyhurst College. One week of presentations and workshops were given on bone and soft tissue trauma, compared to postmortem injuries. Erie, PA.
6/24/2008	2,3	Guest Lecturer, Forensic Collection and Recovery of Human Remains Course at Ontario Police College offered by the University of Windsor and Ontario Police College. Lecture given on bone trauma analysis. Alymer, ON.
6/30-7/1/2008	2	Seminar instructor, Law Enforcement Innovation Center at the National Forensic Academy. Two day training seminar on bone trauma. Knoxville, TN.

1. Presentations; 2. Public Service; Lectures; 3. Workshops, Training sessions; **Other.** Other trauma related presentations, workshops, seminars

Sawmark Analysis Website

In a time when the Internet and computer play such a vital role in daily life, the production of a sawmark analysis website makes perfect sense. Although not in the original proposal, the authors feel strongly that a website devoted to sawmark analysis and the products of this research will make future dissemination of this project more effective and efficient. We have contracted a graphic/website designer to compile and design a website.

Given the evolving nature of this project, a website will provide a means to quickly disseminate new data and information as it is completed. Using a website as an avenue of dissemination it allows us to reach a broad spectrum of readers. Online tutorials will decrease the cost for forensic scientists. This website will use a multi-media approach: text, images, and possibly animations.

The website will house all current and future information regarding this project, including the comparative bone collection database, saw database, information regarding casting trauma defects, bibliography of relevant literature, a condensed version of the sawmark analysis manual, and information regarding validation studies and the accuracy of the method. The website will serve as a means to distribute information regarding current Daubert standards and the admissibility of sawmark trauma analysis in court. The site will also include a variety of case studies that site visitors can access to see examples of saw defects, the application of the developed methodology, and report format.

Comparative Collection Database

The database includes a total of 150 human bone sections (300 cut surfaces) cut with 27 saws. The bone sections are available to other researchers and students for the purpose of future research. We have the means to produce replicas of a specific saw and the residual characteristics it creates in bone with the use of our casting laboratory. A database has been created that will house all information relating to the bone sections. With documentation of each cut and the cutting sequence, a specific saw can be tracked to see if there were changes in the first cut it created versus the final cut it made.

The database is organized by bone (1-19). Each bone has its own page in which general information is compiled: demographic information, overall photographs (anterior and posterior views), processing information, measurement data, cutting sequence, and additional notes (Figure III-1). Each bone section cut from the bone has a tab on the main page, which links it to a page for the individual bone section (Figure III-2). Each bone section has a page that includes information such as: photographs (overall and close-ups), a link to the saw table, and notes. Modifications are continually being made to the database to improve the user-friendliness as well as the addition of information as it is collected.

The comparative collection database was created for two reasons: (1) in order to facilitate the collection of the analysis sample, (2) to produce a collection of sawed bone sections using commonly purchased saws. The collection will give students and researchers access to a vast pool of information that can be used for future research as well as serve a reference for actual sawmark analysis casework.

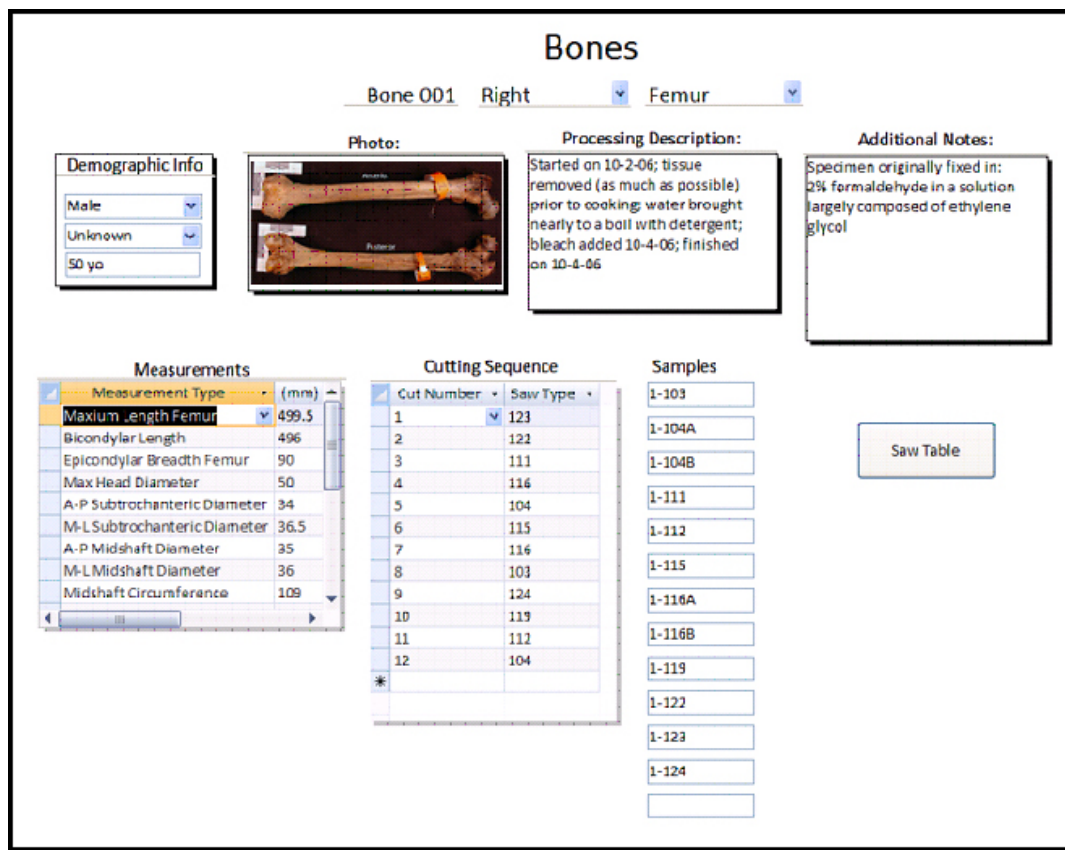

Figure III-1. Example of comparative collection database and information contained within. Users can click on each sample (bottom right) and an additional page will open providing information and photographs related to the specimen and the saw used to create the cut.

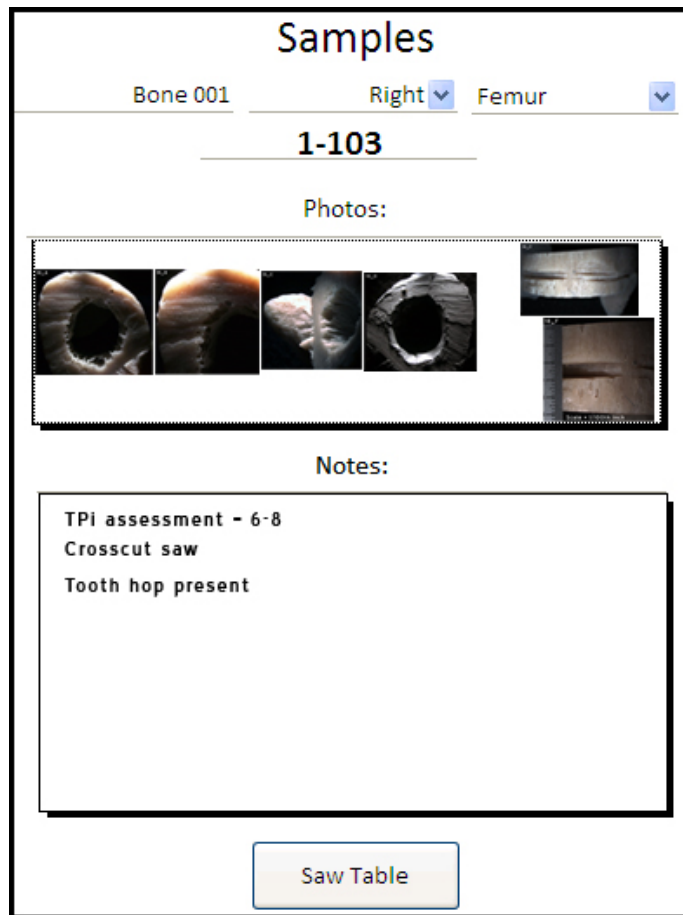

Figure III-2. This figure is an example of a bone section page in the comparative collection database (in this case bone section 1-103 from Bone 1). Notice the collection of photographs each displaying specific characteristics identified in this specimen.

Saw Mark Analysis Manual

Introduction and Background

While toolmark and toolmark examination techniques have had a long-standing history in the literature, saw mark examination and interpretation in bone has received little more than a cursory consideration in the forensic sciences. With financial assistance from the National Institute of Justice and the National Forensic Academy, the primary aim was to develop and disseminate a saw mark manual. While saw mark class characteristics have been available to the public in the form of dissertations, theses, some articles and a few book chapters (Alunni-Perret 2005, Bonte 1975, Andahl 1978, Freas 2006, Guilbeau 1989, Guilbeau 1991, Symes 1992, Symes et al. 1998, Symes et al. 2002), utilization of saw mark analysis is primarily accomplished by the first author (SAS) and dissemination of saw mark descriptions and details has not been overly successful.

The author's first attempt to produce a manual for untrained observers was at an AFTE (*Association of Firearm and Toolmark Examiners*) workshop. The abbreviated manual has become rather popular and is a handy device to use in explaining the relevance of saw mark research. (The original manual has been duplicated in Appendix A.) However, even with its early success, it quickly became evident that a more comprehensive manual on misconceptions regarding saw mark analysis, information on terminology, saw design, class characteristics and the principle cutting action was necessary.

History of Saw Mark Analysis

Two enlightened researchers in the 1970s fought to introduce the topic of saw marks and to make toolmark analysis in bone more useful to forensic scientists. Wolfgang Bonte's pioneering research in 1975 represents the first concentrated effort by a researcher to closely examine saw mark striae in human bone (Bonte 1975). Bonte's research and casework, while the first to recognize features of saw cutting strokes, suffered from several limitations. Among these limitations was a lack of understanding of saw cutting action. In 1978, R. O. Andahl described numerous saw cut characteristics in metal and animal bone (Andahl 1978). His work illustrated how medicolegal cases of human dismemberment could benefit through the analysis of these characteristics. However, his proposed characteristics were at times overly simplified and thus resulted

in less than accurate results for the untrained observer. While Bonte's research expanded the area of toolmark analysis, there was still a need for improvement in the understanding of the tool creating the characteristics, the principles of tool action in a cut, and the value of residual characteristics remaining after a cut. These areas were not addressed in subsequent research following Bonte's and Andahl's studies in the 1970s. Several recent articles and reports published in the *Association of Firearm and Toolmark Examiners Journal* that present case studies on the subject of saw mark analysis generally fail to offer detailed descriptions or comprehensive standards of analysis on the subject.

Symes (1992) was the first researcher to publish a doctoral dissertation on the topic of saw mark analyses of cut bone. Since that time, he has provided analysis of saw marks in nearly 200 dismemberment cases and approximately 700 to 1000 knife cut wound cases. Symes' methodology is based on his evaluation of the diagnostic potential of several features of saw marks on bones, the ability of these features to indicate saw dimensions and the potential of these characteristics to discriminate between different classes of saws and knives. Research conducted by Symes and associates (Symes et al 1988, Symes et al. 1989 a & b, Symes et al. 1990; Symes et al. 1996, Symes et al. 1998; Symes et al. 2002) provide an excellent foundation from which to continue efforts to standardize an accurate and reliable methodology for the analysis of saw and knife marks to bone. While occasional book chapters briefly describe this work (Symes, Berryman et al. 1998, and Symes et al. 2002), each represents a minor aspect of the overall scope of toolmark analysis.

Knife wound analysis has also received little attention in forensic investigation (Symes et al. 1999). Although knife stab wounds are second only to ballistic injuries as the major cause of violent death in this country, the widespread use of meaningless and misleading descriptors such as "sharp", "single-edged blade" and "hesitation mark" (which erroneously implies behavior) are common and may result in serious misinterpretation by attorneys, judges and juries.

Sharp force trauma can involve a variety of weapons and tools. Any tool with a sharp edge can produce incised wounds. Most of the incised wounds are created by some class of knife and are recognized as sharp force trauma. The wound is commonly

termed a knife stab wound (KSW). The term KSW is often misused, particularly by anthropologists, since most wounds they examine are without soft tissue. Many of the wounds to bone are knife cut (incised) wounds, but are not necessarily due to stabbing. Using the term knife cut wound (KCW) instead of knife stab wound is more accurate and inclusive of many actions. A KCW in bone is indicated when a sharp edged tool superficially incises bone while traversing over the surface of the bone. While a non-stabbing KCW often follows the contour of a bone, a stab may puncture, nick, or gouge a bone as it enters the body and proceeds externally to internally.

In addition, stereotypical adages are commonly taught to forensic students. For example, a claim that the lack of features in knife cut wounds would 'never rule out serrated knives,' again deters the analysis of sharp trauma. While the analysis of knife cuts to bone is not the primary focus of this research, a straight edged or serrated knife used in a 'sawing' motion has been examined in this project. However, if cut marks follow the contour of a bone onto different surfaces or if a knife is used in a reciprocating motion, the resulting features most likely indicate postmortem dismemberment rather than perimortem trauma to the victim (Symes et al. 2002). The misconceptions regarding knife and saw cuts, along with the lack of tested and validated standards demonstrate the need for a published practical guidebook on knife and saw marks in bone.

The proper documentation and analysis of saw marks can significantly contribute to the interpretation of a criminal act. However, frustration and confusion often arises with regard to proper analysis and examination of saw injuries as well as the retention of bone. The purpose of this research is to address common misconceptions regarding analysis procedures and, at the same time, develop a standardized protocol for analysis of saw marks in bone so as to meet current Daubert evidentiary standards. Likewise, the aim of this manual is to give forensic anthropologists and toolmark examiners a working knowledge of saw mark analysis in bone. The manual is not meant to be a comprehensive volume detailing every element and minutiae regarding saw marks in bone, but rather a guide and resource that will help facilitate, and hopefully improve the accuracy, of saw mark analysis.

Current Status of Toolmark Analysis in Bone

Despite a rise in interest and a need for saw mark analysis, the attempt at analysis, has become a dismal scientific endeavor. While anthropologists and pathologists conduct numerous saw and knife mark analyses on dry and fresh bone, most professionals are reluctant to examine this bone within the soft tissue. Reasons for this avoidance include, but are perhaps not limited to: 1) difficulties in examining and transporting decomposed tissues, 2) a lack of equipment or training to process the remains after soft tissue examination, and 3) a general avoidance or lack of interest in the soft tissues. Unfortunately, the situation often applies to forensic anthropologists and occasionally to medical examiners and coroners.

The first author, with others, has continuously campaigned for the preservation of context of human remains in any medicolegal situation (Dirkmaat et al. 2008). Part of this contextual integrity involves the preservation, exposure, and complete examination of soft and osseous tissues. If law enforcement recovers the tissues and an anthropologist is merely brought in to process the soft tissues from the bone, then the tool mark expert only receives a pair of cut elements, without context, in the crime laboratory. In this instance, the anatomical orientation (for direction of cut) as well as any injuries to the soft tissue is lost.

The first author (SAS) has demonstrated that class characteristics contribute significantly to criminal investigations. Investigators need to know the type of saw to look for and be able to demonstrate dismemberment behavior to a jury or judge. While many toolmark examiners attempt to make individual tool mark assessments, class characteristics must be emphasized when analyzing saw marks.

Even though criminalistics have shown that there is limited potential for positive identification of a saw from comparisons of saw marks on bone, the value of class characteristics of saw marks has been recognized.

Saw mark research is focused on collecting data on variation found in microscopic features of cut bone. Data are then applied to saw blade and tooth characteristics of size, set, shape, and power. This information is used to indicate saw class, subclass, or type. The narrowing of the field of possible tools that could have potentially been used in

a crime makes saw mark characteristics a valuable "tool" for the forensic examiner. (Symes 1992:6). Unfortunately, a standard methodology for saw mark analysis is lacking, and the field is hindered by numerous misconceptions.

Misconceptions Regarding Saw Mark Trauma Analysis

The authors have identified eight (eight) common misconceptions which plague the field of bone and tool mark trauma analysis.

1. First and foremost, there is a belief that saws - by the action of sawing - destroys any diagnostic features that could be used to identify a class of, or a specific, saw (See Symes 1992). Not only is this incorrect, but it has greatly diminished saw mark analysis in a forensic setting and has led to its abandonment as a source of potential evidence. Tool mark examiners confronted with analysis problems regarding saw marks, often comment that there is a lack research in the field.
2. The second misconception is that diagnostic marks on bone are created only when the blade is worn or damaged; thereby resulting in unique individualizing characteristics. While the focus upon these "defects" is common, all blades leave diagnostic marks as they cut, regardless of wear. The correct interpretation of these characteristics can lead to a valuable identification of classes of saws and knives. In addition, correctly identifying the class of tool used (i.e., hacksaw, serrated knife, etc.) is useful for narrowing down the search for the suspected weapon or tool. Therefore, the assumption that a comparison is only necessary once the individual tool is found is incorrect, as an accurate identification of a class of tool – as indicated by tool mark features - can direct the investigator to sub-classifications, such as wavy set hacksaw, large toothed serrated knife.
3. The lack of proper equipment used to analyze saw toolmarks, whether it is too little or too much magnification has prompted another common misconception amongst anthropologists. The problem is that low-grade dissecting microscopes, commonly found in anthropology departments, are

inadequate for toolmark examination. Most often, these microscopes do not permit the entire bone to be examined at one time. Additionally, many anthropologists are inexperienced in using microscopes, which often leads them to latch on to sophisticated technology, such as a scanning electron microscopy (SEM), before evaluating more appropriate means of analysis. Often it appears that anthropologists expect high magnification SEM to train them in identifying and describing features observed in saw mark analysis. SEM is unnecessary for accurate saw mark analysis in bone and in most cases has been shown to hinder the examination (Freas 2006). With that said, there has been excellent SEM work research performed on cut marks characteristics, namely Bush et al 2009; Saville et al. 2006 and Shipman 1981, to name a few.

4. The fourth misconception is that a *naked eye* examination of a cut bone surface can accurately indicate tool class. Many anthropologists are misled by the erroneous concept that all one has to do is to compare the cut surface of bone with the residual kerfs in order to classify the tool responsible for creating the defect. Unfortunately, the overall pattern one observes on the cut surfaces of bone is of little use in saw mark analysis. This is due to the fact that saw teeth change or wear when cutting hard material. In a series of cuts, the bone surface changes and indicates that the saws are continually changing. In Figure III-3, handsaw dismemberment to a proximal humerus is shown. The lack of similarities between the two bones from the same dismemberment created by the same saw is astonishing.

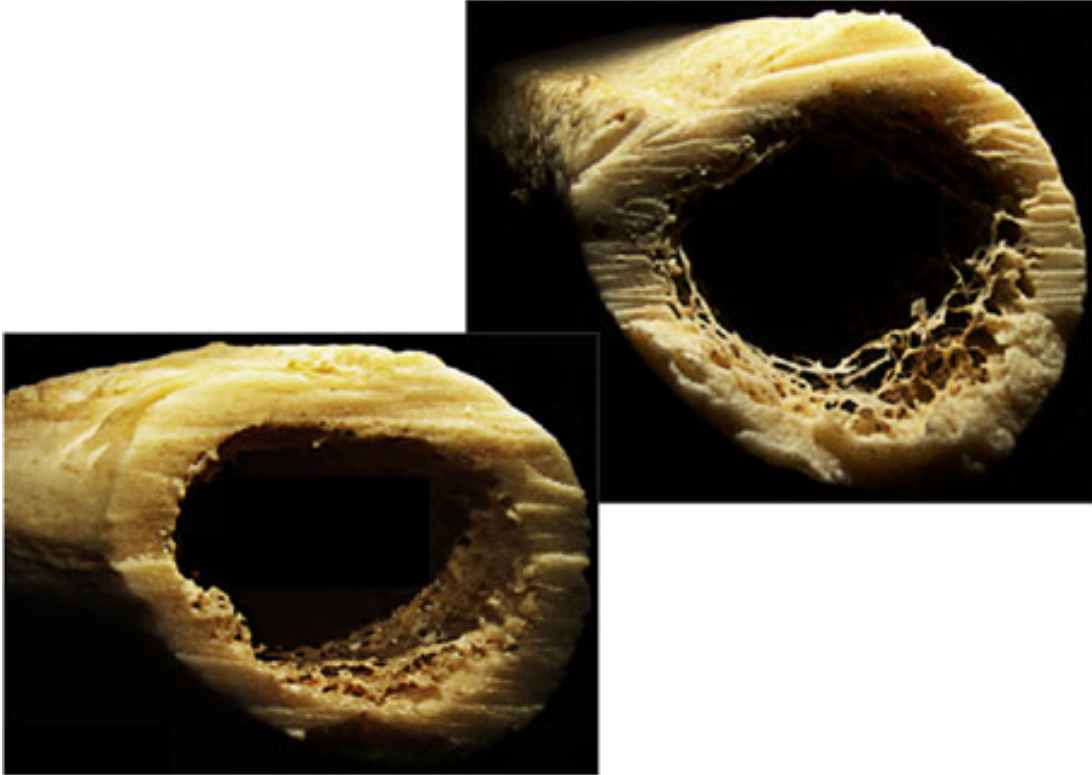

Figure III-3. This represents two sides of a dismembering cut in a humerus, created by a handsaw. While the same saw make these cuts, the cut surfaces look dissimilar.

5. Bones cut during the process of dismemberment commonly exhibit smooth cut surfaces and straight edges. A common fallacy is that a power saw must have produced a straight cut surface. Saws are designed to cut hard materials in a straight manner, which results in a straight edge, and relatively smooth surfaces. Thus, these characteristics are common to most saws, not specifically mechanically powered tools.
6. The term “hesitation marks” was originally used for suicidal knife cut marks to skin, where inexperience and reluctance to continue the cutting action may have been related to pain and the resistance of soft tissue to the knife slashes (Di Maio and Di Maio 1993: 183-4; Spitz 1993:271). For some reason “hesitation marks” has been attached to any shallow cut marks associated with soft tissue. The author’ suggests that a ‘hesitation mark’ is misleading (Symes et al 1999); even more ridiculous, is when this terminology is applied to saw marks on bone. Repeated false starts in bone

are not the result of the victim's hesitant, last dying act or the perpetrator's hesitation to decapitate the victim (Figure III-4).

Hand saws use a reciprocating motion to cut, similar to the use of a knife to cut soft tissue. A reciprocating motion should not be termed hesitation; rather, it reveals more *persistence* from the perpetrator than *hesitation*. In this manner of logic, one could consider false starts to be "persistence marks"; a determination more emotionally intuitive to the criminal intent of dismemberment.



Figure III-4. Numerous cuts on a proximal femur from saw dismemberment. Despite the number of cuts and the reciprocating motion, it would be in error to call these hesitation marks.

7. Measuring striations and features of a saw cut surface in an attempt to produce diagnostic information about the cutting tool is largely misguided and erroneous. Anthropologists are often the first to resort to measurements of observable characteristics in human remains. However without knowledge of the principles of cutting action of saws and knives and of the response of bone to this reciprocating and continuous motion, the data from these measurements may misrepresent the facts.

Measurements are necessary in saw mark analysis in bone, but caution must be emphasized for metric analyses of a mechanism or motion that is not completely understood and where essentially, many styles of blades (teeth), can exist. Problems arise when the measurer does not recognize the difference between force (human intervention) and saw design.

A simple way to demonstrate this principle is to examine a knife stab (KSW) wound, from a serrated knife, into a material that mimics costal cartilage. A KSW can create a variety of patterns, which are often dependent on the orientation of the knife. In Figure III-5, a stab and chop wound are demonstrated. A chop wound, as opposed to a KSW, may create striae that accurately mimic dimensions of the tool, while a typical KSW, which strikes perpendicular to the surface, creates a changing – rather than a continuous – striae pattern. While the patterns of continuous striae are associated with chop wounds, measurements of these patterned striae have a limited utility

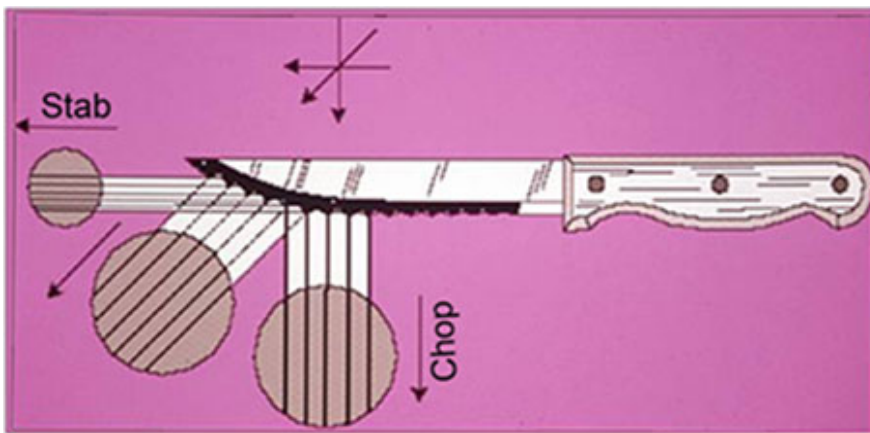

Figure III-5.
Illustration of knife with projected striae formed by teeth, as is dependent on the orientation of the knife.

In Figure III-6, a dismembered femur is shown. One cut surface shows many different directions of cut, with the large arrows indicating direction of saw progress-perpendicular to saw stroke. The cut surfaces also show a large range of striae frequency. Area A illustrates extremely uniform and broad striations, whereas Area B demonstrates extremely fine striae. Does this indicate two saws?

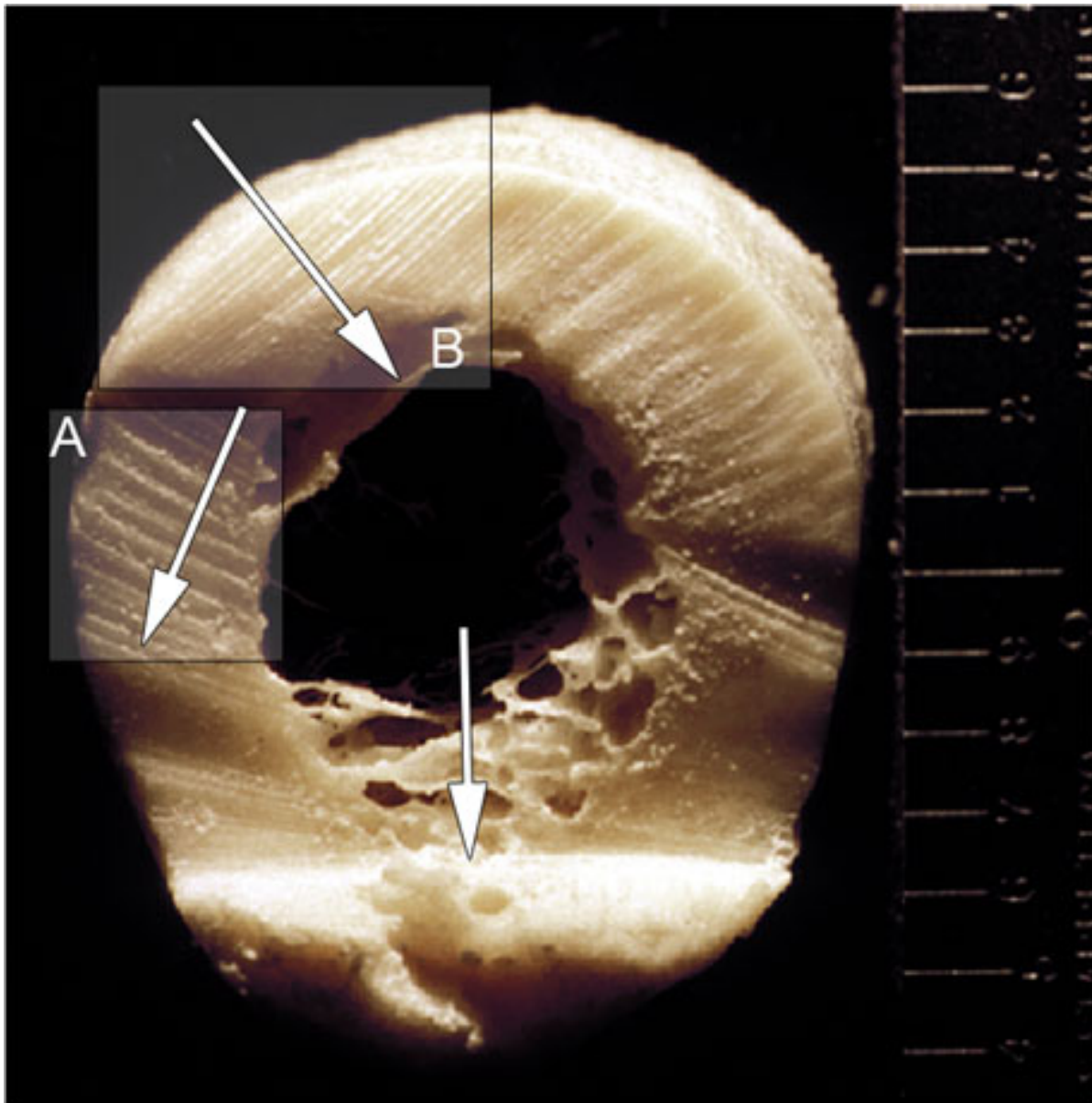

Figure III-6. Dismembered femur. Three directions of saw progress (white arrows) and at least two striation density patterns.

Interestingly enough, each of these areas were created with a power saw. The saw left a fixed radius bending striae that curve into the bone, which is a characteristic feature of a power circular saw. In this case, the distance between the striae was caused by each saw tooth being forced to cut a deep swath in the bone Figure III-6 Area A, whereas in Figure III-6 Area B, where less force was applied, the teeth cut shallow swaths through the bone (Area

- B). Despite the fact that researchers have suggested that the metric difference between striae indicates the frequency of teeth on a circular blade (Haig 2006), it is the author's opinion that in this case, this is the same saw; this is the same blade; the differences between the striae are simply a demonstration of heavy versus light force applied (Figure III-6).
8. A common misconception is that saws and knives are similar in appearance, due to the fact that both are considered to be sharp force trauma. However, knives and saws are used for different purposes and are distinctly different in their morphological and microscopic appearance.

Confusion often occurs when trying to identify weapon class associated with blade and knife wounds. Knives can be differentiated from other blades in that knives are tools with a thin blade that sometimes terminate in a point. Knives also commonly have blade bevel (blade tapering) and always have at least one area of edge bevel (sharpened edge) on the blade. Tools such as box cutters, razor blades or machetes can be classified as knives while blades like propellers, augers, and tree chippers are not (Symes et al. 2002).

Saw marks to bone are classified as sharp trauma since there is always some portion of a saw tooth that is incising bone. The cuts created by a saw can be seen on the kerf wall striations. Saw cuts can be distinguished from knife cuts since saws leave a squared, cross section kerf floor. Filed crosscut (sharpened) saw blades create a kerf floor that when viewed in cross-section resembles a "W." In contrast, bevel-edged knife blades create a "V"-shaped kerf floor when viewed in cross-section, regardless of whether there are teeth manufactured in the blade or not (Symes et al. 2002).

Saws can easily be separated from knives, because knives, unlike saws, have an edged bevel. Saws are generally designed to cut a wider swath than a knife blade. The wider cut is possible due to the lateral bending of every other tooth (tooth set) of the saw blade. True crosscut saws have consecutive teeth that are filed at opposing angles (usually 70 degrees). The filing creates a tooth that terminates in a point and essentially takes on the shape of a

sharpened blade that cuts (like a series of knives) rather than chiselling the material. Classic rip saws do not have filed teeth and create a flat bottomed kerf.

Recognizing the differences between cut marks to bone caused by knife blades and those caused by a saw are essential in toolmark identification, especially since both classes of tools may be involved. Knowledge of the types of tools available and how they are manufactured can only be beneficial to assessing the forensic significance of toolmarks in bone (Blumenschine et al. 1996, Burd et al. 1942, Burd et al. 1957, Burd et al. 1968). Since knife cuts are not the main focus of this chapter, we consider knives only when they are used in a sawing motion.

Only when the above-mentioned misconceptions are overcome and the evidentiary and forensic potential of saw marks in bones are recognized, can the value of saw mark analysis be realized. And finally, it is essential that the value of toolmarks on bone is recognized to the extent that the bone is retained as evidence. While soft tissue is routinely retained as evidence, the tissue that is unchanging, “a moment frozen in time,” is often not (Smith 1996).

Diagnostic Features of a Saw

Tool mark examiners typically look for “unique” features that can be used to produce a positive match between the bone and the tool in question. Conversely, saw mark analysis does not necessarily identify a specific weapon, but rather a class of tool; these features are referred to as “class characteristics.”

Vast ranges of saws are available on the market and can be categorized into approximately 15 classes of tools. The object of saw mark analysis is to recognize characteristics on kerf walls and floors in bone that may accurately reveal size, shape, set, power and direction of a saw.

Saws are defined as blades with teeth. When analyzing saw features, one must consider the way in which the teeth are “set.” The set produces distinctive marks in the cut surface. For example, if teeth are bent (set) right and left, the teeth carve out a wider kerf

(the actual saw trough) than the blade width. This design allows a blade to deeply penetrate a hard material without binding. Other design features usually revolve around the teeth, particularly with regard to shape and size.

A few basic concepts about saws and saw blade actions are necessary to know before attempting to interpret saw marks in bone. All saws blades have teeth which leave cut patterns in an object. As the saw teeth cut into bone, a groove or kerf is formed (Symes 1992; Symes, Berryman et al. 1998). Saw mark analysis involves examination of saw cut kerf floors and walls. Floor contour includes false starts and, occasionally, breakaway spurs. Kerf floors offer the most information about saw class by revealing the relationship of saw teeth to each other. The information includes set and number of teeth per inch (TPI) (Table 3).

Kerf walls provide evidence about teeth per inch, saw power, and the direction of cut. Knives, when used in a reciprocating/sawing motion, can also be considered saws. However, serrated knives lack saw set (lateral bending), so they create a visibly narrow, 'V'-shaped kerf walls and floors.

Set is defined by the teeth that are bent laterally to a particular side of the blade and set is represented by striations in the kerf wall. Tooth set creates a kerf wider than the saw blade with a floor that has a squared off 'U'– or 'W'-shape (Figure III-7). The profile, depth and frequency of these striae may represent the shape of the blade, the amount of energy transferred to material and the motion in which the blade travels to cut through bone. Both the floor and walls contribute to interpretations of direction of cut. The object of saw mark analysis is to recognize characteristics in kerf walls and floors that may accurately reveal size, set, shape, power and direction of cut (Symes et al. 2002).

The breakaway spur is the projection of the bone at the floor of the terminal cut, where the bone fractures. This spur has a mirror image in the form of a notch, which forms on the other side of the cut bone (Figure 7). The breakaway spur is often as diagnostic as the kerf floor. The size of the spur often depends on the amount of force applied across the bone. For instance, the weight of a handheld circular power saw or chain saw (offering leverage) often produces a large breakaway spur than a saw, which does not provide leverage. Simply, the pound of weight and/or leverage in front of the saw grip greatly increases the force applied to the bone.

Handsaws are classified into two basic types: rip and crosscut. The rip saw is designed to "rip" wood with chisel-shaped teeth. The crosscut saw is designed to "cut" wood fibers across the wood grain. Almost all saws are measured by the frequency of their teeth, i.e., points per inch (PPI) or teeth per inch (TPI). There is generally one more point per inch (PPI) than tooth per inch (TPI). In forensics, TPI, or distance of the teeth from each other, is measured in inches. TPI is considered a description of saw size (Table III-2), and TPI distances are listed in Table III-3.

Differences between crosscut and rip teeth are illustrated in Figure III-7. Rip saws have a flat chiseling tooth, whereas crosscut saws have consecutive teeth filed at opposing angles (usually 70 degrees). This filing creates a tooth that terminates in a point, or wedge, essentially taking on the shape of a sharpened blade that cuts rather than chisels material. The teeth of a rip saw are not angled or filed. The teeth are simply notched out of the blade. As such, these saws essentially chisel out material rather than cut it.

These differences in design are used to establish saw classes. In most saws, teeth have a front and a back. The front of the tooth is designed to do the majority of the cutting as it bites into the material. Generally, reciprocating saws are designed to saw with a cutting stroke and a passive stroke. In order to distinguish a cutting stroke from a passive stroke, run a saw blade over the back of your hand. The passive stroke is easily distinguished from the cutting stroke. When the cutting stroke is forces, it is likely to cut the skin; while the passive direction slides over the skin without cutting it.

The front side of the tooth bites (steeper angle) during the cutting stroke, while the back side of the tooth slides on the passive stroke. Enlarged sections of two saw blades are shown in Figure III-7. Each diagram has arrows that indicate one of two possible directions of motion. The push stroke in these illustrations is a cutting stroke. Both these rip and crosscut saws designated in Figure III-5 are considered common "Western" saws. The Western-style rip and crosscut saws are shown to cut in a forward motion manifesting a push stroke.

Most saw blades are designed to cut hard material and thus have teeth that are set, or are laterally bent. The most common, or typical, is the alternating set which means that adjacent teeth are bent in opposite directions (see Figure III-8). However, more complicated designs such as raker, which has every other tooth bent in an opposite

direction, or wavy sets, which have a series of teeth pointed in one direction or the other, can be found.

Table III-2. Saw characteristics found in cut bone that assist in the diagnosis of saw class. Characteristics are categorized by where they are found on a cut bone.

<u>Kerf Floor (False Starts-Breakaway Spurs)</u>		<u>Kerf Wall (Cross Sections)</u>	
Size	Minimum Kerf width Tooth Trough Width Floor Dip Tooth Imprints Blade Drift Bone Islands	Size	Tooth Hop Pull Out Striae (Tooth Scratch) Harmonics
Set		Set	
-Alternating	Blade Drift Bone Islands	-Alternating	Harmonics
-Raker	Parallel Striae	-Raker	Little Cut Surface Drift
-Wavy	Complicated Floor Striae Drift is Subtle in Shallow	-Wavy	Complicated
Kerf		Shape	
Shape	Striae Contour Straight Curved Rigid (Round) Fixed		Striae Contour Straight Curved Tooth Orientation Push (Western) Pull (Japanese) Tooth Angle Rip Crosscut (Filed)
Radius	Flexible Wrap		Exit Chipping
Around		Power	Energy Transfer Consistency of Cut Material Waste
Power	Energy Transfer Consistency of Cut Material Waste		Polish Cut Surface Drift
	Polish	Direction	Blade Progress
Direction	Blade Progress False Start to Breakaway		Blade Cutting Stroke Entrance Shaving Exit Chipping Kerf Flair (Handle)
Notch/Spur	Blade Cutting Stroke Kerf Flair (Handle) Exit chipping		

Table III-3. Teeth Per Inch

Saw Tooth Distance		
In	cm	TPI
0.01	0.03	100
0.02	0.05	50.0
0.03	0.08	33.3
0.04	0.10	25.0
0.05	0.13	20.0
0.06	0.15	16.7
0.07	0.18	14.3
0.08	0.20	12.5
0.09	0.23	11.1
0.10	0.25	10.0
0.11	0.28	9.10
0.12	0.33	8.30
0.13	0.33	7.70
0.14	0.36	7.10
0.15	0.38	6.67
0.16	0.41	6.25
0.17	0.43	5.88
0.18	0.46	5.55
0.19	0.48	5.26
0.20	0.51	5.00

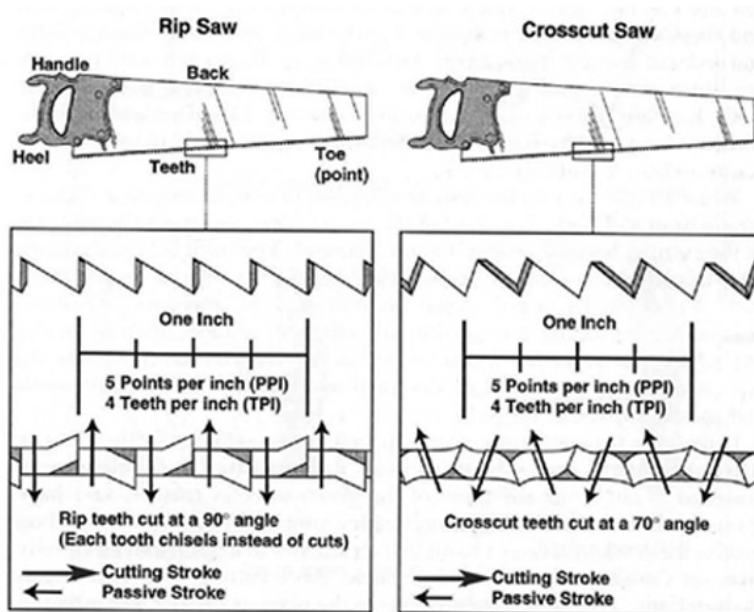

Figure III-7. Rip versus crosscut saws, with typical alternative set.

Test

Examine a blade and teeth on end. A simple crosscut saw is a blade with teeth cut out, usually with set. If you see a more complicated design, where the leading edge of the saw tooth appears as a series of small knife edges, a crosscut saw (filed teeth) is probably indicated. Examine. Typically you see alternating set, but some saws, like hacksaws, commonly have raker or wavy set. (Figure III-8.)

Saw Kerf

The kerf is defined as the area cut, or the walls and floor of a cut. Floors are expressed in false-starts and occasionally in breakaway spurs. Kerf floors, when present, offer the most information about each tooth in terms of the relationship of the tooth points to each other or the set (lateral bending), and number of teeth per inch (TPI) (Table III-2). Kerf walls can also offer information about teeth per inch, saw power, and direction of cut. Knives, when used

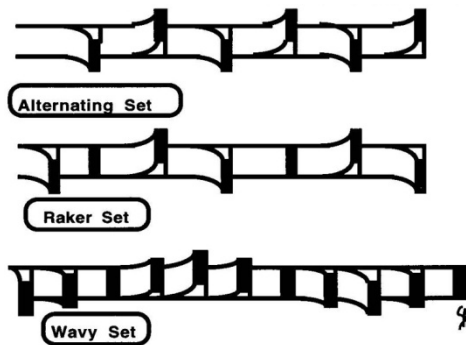

Figure III-8. Saw Tooth Set

in a reciprocating/sawing motion, are also considered saws. However, serrated knives lack set, so they create a narrow, 'V'-shaped kerf, whether used in a reciprocating or chopping motion (Figure III-9). Most saw blades designed to cut hard material have teeth that are set. Tooth set creates a kerf wider than the saw blade (Figure III-9) with a floor that is a squared off 'U'-shape or is 'W'-shaped.

Break Away Spur and Notch

The breakaway spur is the projection of bone at the floor of the terminal cut, where the bone finally fails in a fracture. This spur has a mirror image in the form of a notch, which forms on the other side of the cut bone (Figure III-9).

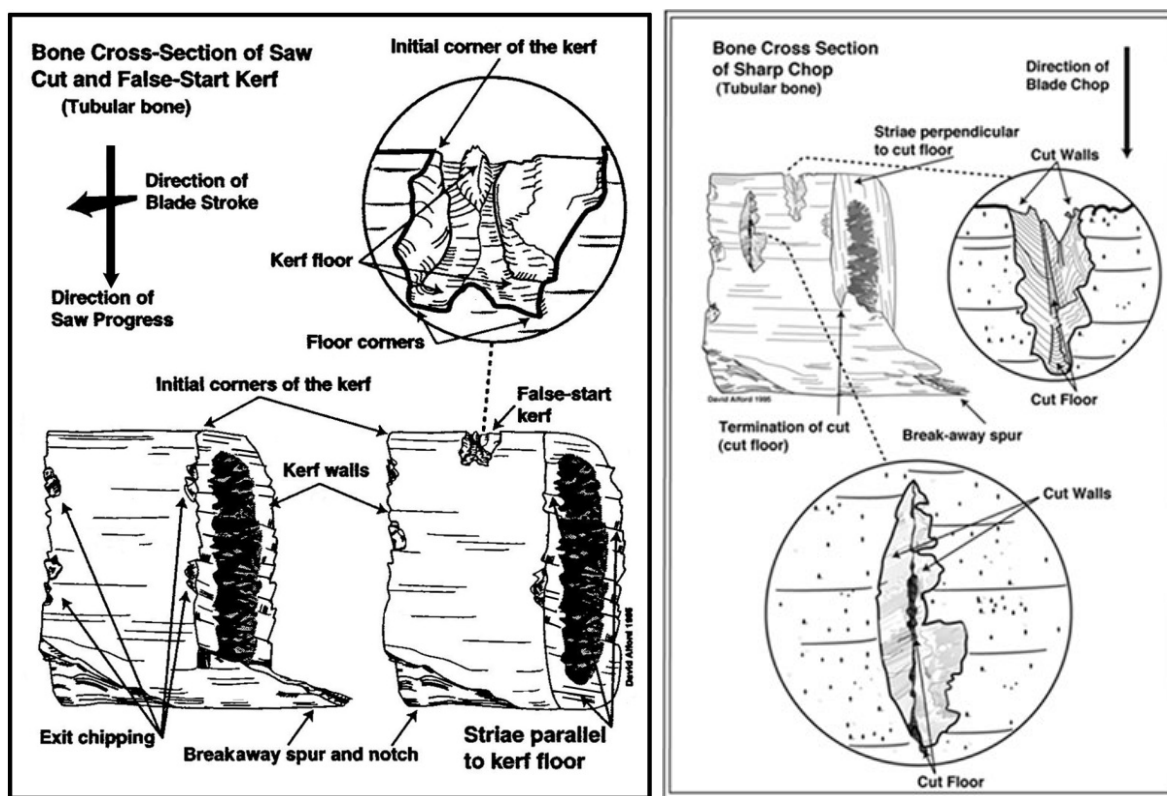

Figure III-9. Saw and knife kerf showing walls and floor of a false start and complete cut.

Break away spur is a projection of uncut bone at the terminal end of the cut after the force breaks the remaining tissue. The breakaway spur is often as diagnostic as the kerf floor. The size of the spur often depends on the amount of force applied across the bone resulting in a fracture. For instance, the weight of a handheld circular power saw or chain saw (offering leverage) often produces a large breakaway spur.

Principles of Cutting Action

The act of sawing is essentially pushing, pulling or rotating the teeth of a saw blade in such a manner as to cut (needle point teeth designed like a knife) or chisel (teeth designed similar to a flat bottomed wedge) through material. To understand residual characteristics of saw cuts, it is necessary to examine the action of the saw blade. Saw action includes the slicing or shaving of a knife blade or chisel tooth through material, as well as the actions of the banks of teeth working in unison or opposition to the blade. Since the saw teeth perform the cutting, actions of each tooth and the combinations of these teeth on a blade must be examined. Saw actions need to be examined in terms of size, set, shape, power, and direction of cut as well as how these various actions influence the cut material (Symes et al. 1998; Symes et al. 2002).

Blade and Tooth Size

Saw size is simply represented by the size of the cut made by individual saw teeth and by the combined action of saw teeth. The cut represents the minimum width of a saw tooth impression and kerf. Most importantly, size reflects the number of saw teeth per inch, which is a common classification for all saws. Features are classified into characteristics of saw motion and saw tooth residual evidence, or the residual characteristics that occur when the saw stroke is interrupted. When the blade reacts to the introduction of each tooth point on an object with an up-and-down motion, or when the saw blade responds to set teeth through a rhythmic side-to-side drift, the cuts can often be interpreted in relation to teeth per inch. Obvious residual evidence is also diagnostic of TPI when a saw is stopped in mid-stroke or pulled from the kerf, leaving telltale striae.

Blade and tooth size are other factors of saw design. Universally, tooth size is classified by the number of teeth per inch on a blade (Figure III-10). There are two ways to classify a blade: 1) points per inch (PPI) or 2) teeth per inch (TPI) (Self 2005, Rae 2002, Wilson 1994, Nagyszalanczy 2003). The number of points per inch is generally one value greater than the number of teeth per inch (Figure III-10). Important to note is that the quantifiable characteristics of saw cuts observed within a kerf floor and wall are more easily reflected in the number of TPI than the number of PPI. All references to the size of teeth will universally be in terms of teeth per inch or TPI.

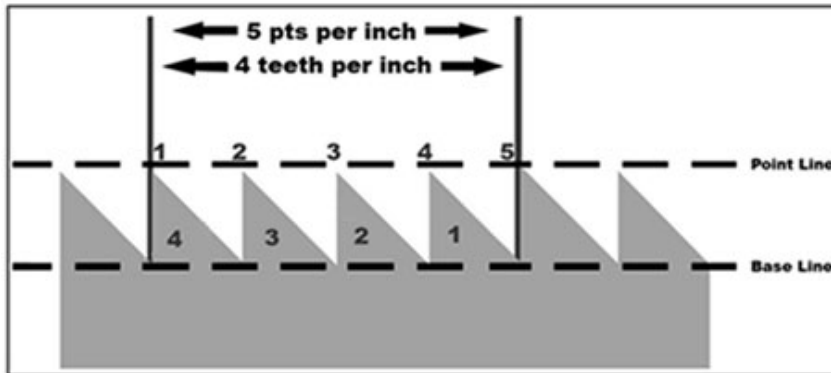

Figure III-10. Difference between teeth and points per inch. Teeth per inch (TPI): emphasis of the research.

More TPI on a saw increases the smoothness of cutting, while slowing down the speed of the cut. Conversely, fewer and larger teeth are designed to more efficiently saw softer materials. A wide, alternating set with narrow width teeth is commonly found in larger toothed saws. If this combination of features produces a cut that is similar in width as two side-by-side teeth, then islands of uncut material may be visible in the middle of the kerf. Therefore, the combination of tooth width, set, and distance between teeth, essentially dictates the speed and amount of material cut with each stroke or rotation of the blade.

Some saw blades are not classified by TPI or PPI. Included in these blades are power circular saw blades and flexible saws, such as the Gigli (wire) and rod (grit imbedded). Masonry circular saws and flexible saws do not have blades with teeth like other saws; rather the teeth are formed by grit impregnated blades, or by wrapped wire.

Blade and Tooth Set

Even though the above definition of a saw, i.e. blade with teeth, implies nothing of set, the altering or bending of teeth to reduce binding is an integral and tested part of saw design that has existed for close to 2000 years (Disston 1922). While saw blade tooth set is essential to the effectiveness of most saws, it is not required. Four saws, which had no definable set, include a serrated knife, the metacarpal saw (no bending, but a set is carved into the blade) and both flexible saws.

Teeth are generally set according to their size. The amount of tooth set in saws that fall into 4 to 16 points per inch is generally 0.003 to 0.005 of an inch. As a rule, the kerf does not exceed 1.5 times the thickness of the blade (Cunningham and Holtrop 1974:84;

Jackson and Day 1978:75-76). If the set is greater, the teeth bend laterally to the extent that the material will be untouched in the midline as the tooth reaches its greatest flare. A ranker set is defined as a greater bending of the tooth and is designed for softer material, such a soft wood as opposed to a hard wood (Salaman 1975:405). The ranker the tooth set, the more lateral bending of the teeth which creates a wider kerf.

Alternating Set

As mentioned previously, there are three types of set most commonly used for spacing and arranging saw teeth, these include: alternating, raker, and wavy (Figure III-11). Alternating set design is applied to many shapes and sizes of teeth. Certain actions occur in blades, which necessitates that every other tooth be set in a different direction.

In order to understand the cutting action of a blade with an alternating tooth set, it is important to first examine the actions of a single tooth, then to combine these with actions of the consecutive teeth. Saw teeth are set so that the cut produced is wider than the saw blade. As a single set tooth first enters the material, the tooth seeks an orientation parallel to the direction of the blade and to midline of the material. The midline orientation is compromised as the next tooth enters this material. The second tooth is alternately set. Therefore, it enters the material from a position opposite the previous tooth. In doing so, it seeks a different midline from the first tooth, while also attempting to cross the cut path of the original tooth. This pattern is further explained under 'Blade Drift.'

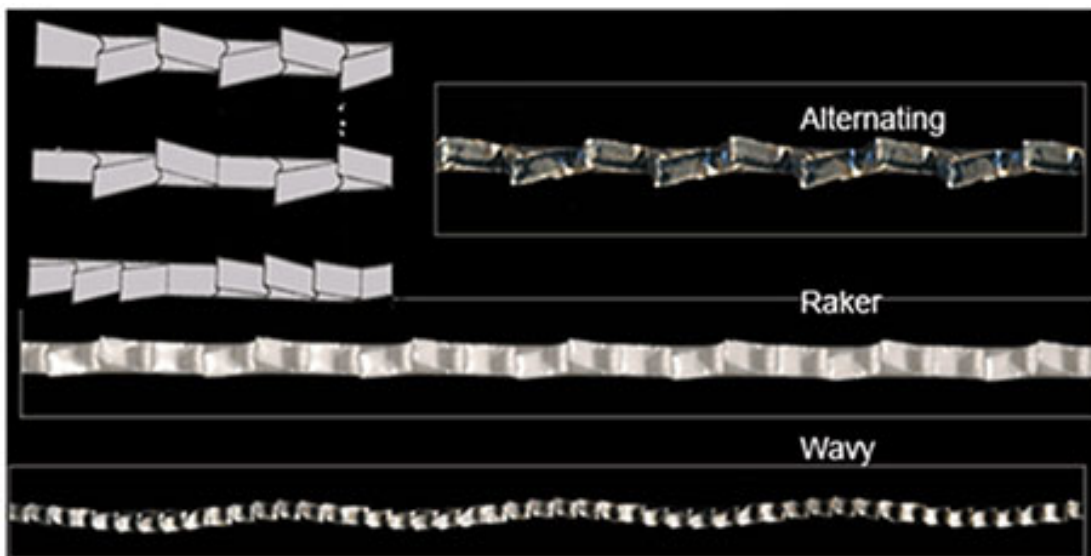

Figure III-11. Illustrations of the three major types of saw blade set.

The pull to the midline of the second tooth sends the first tooth in a direction parallel to the second tooth, until a compromise between the two teeth is reached. The parallel drift reverses each time a new tooth enters the material. Essentially, the new teeth enter the same two patterns of the first two teeth and approximate the same grooves. Since there are two rows of teeth set in an alternating pattern, a predictable pattern can be established. Tooth drift is defined as the pattern of teeth drifting across the kerf floor. Drift pattern is most noticeable at the beginning or end of a cut in a tubular bone, as there is little material to offer resistance or to trap the blade's motion. Once the blade is immersed in the material, much of the tooth drift is suppressed.

Raker Set

An intricate design in the cutting edge of a saw may create a more complex picture in the residual kerfs. As the term implies, rakers are specialized teeth designed to rake sawdust or imperfections from the kerf floor rather than to consistently cut or chisel. Blade teeth 'clean up' after the previous teeth and thus modify the kerf. Raker sets complicate saw striation examination, due to the fact that they are not symmetrically placed between every tooth. Rakers appear in a series of teeth, most commonly every third, fourth, or fifth tooth (Figure III-11). The raker design alters the kerf floor shape, the harmonics of the cut (peak and valley patterning on the bone cross section), and the predictable drift of an otherwise alternating set blade.

Raker sets are generally seen in two major types of saws, pruning and fine toothed bow saws (FTBS). Saws with raker teeth analyzed in this study include buck saws and hacksaws. Pruning saws, by design, use large teeth combined with rakers and gullets (large space between large teeth) to clear the soft wood debris cut with the teeth. Rakers are generally shorter than the regular teeth since they are designed to rake out debris in the kerf, to smooth the kerf floor and to clean the kerf. Jackson and Day (1978:77) describe the lance tooth set that has four teeth bordered by rakers with a large gullet on each side of the raker; this raker is designed for cutting unseasoned wood. Variations of this type of raker set are found in common hand pruning saws. Fine toothed bow saws are designed to cut through harder materials, such as metal. The rakers associated with these saws are identical to the other teeth, only they have no lateral bending (set).

Raker teeth also inhibit blade drift. Since it is not set to one side or the other, a raker tooth enters the material on the central path of the cut. As the raker teeth traverse through the midline, they inhibit the set teeth from diverting into a rhythmic side-to-side movement, especially in FTBS. Saw blades with shorter raker teeth (like pruning saws) could also be diverted from their central path by falling into a deeper groove created by a previous alternating tooth; therefore a unique kerf floor or an unsymmetrical floor contour could be created. However, one must keep in mind that the rakers of pruning saws generally occur at a rate of one out of five teeth or less and tend to be shorter than the cutting, or chipping, teeth. With this design, the raker's influence on blade drift is likely minimal.

Wavy Set

Wavy set teeth are distinct from both the alternating and raker tooth sets. A wavy blade set cuts on the same principle as an alternating blade set however, wavy set blades generally have a cluster of minuet teeth which makes setting each tooth difficult. Rather than a set for each tooth, groups of teeth are alternately bent side to side (Figure III-11). When examined on edge, the blade forms a wavy pattern with each wave, or cluster of teeth, functioning as a single alternately set tooth.

Saw blade set has numerous potential features that can be used to diagnose a saw cut. For example, mass production or poor craftsmanship may produce a tooth set that is not equal when bending to the right as opposed to bending to the left. If alternating saw blade sets do not set each tooth equally, the saw cut may produce walls that are dissimilar to each other. In Figure II-12, the clavicle has been cut with a saw. The saw consistently produced a striated wall and a smooth wall in each cut (kerf), but it had an asymmetrical set, which makes the two halves appear different (e.g., see reconstructed clavicle shaft in photograph insert).

In Figure II-13, the proximal cut wall of the right and left femora are shown. One wall is relatively smooth, while the other has visible residual striations. In this case the suspected tool had been a meat saw. This pattern - coupled with indicators of power stroke - confirmed that the direction of the saw blade had been reversed in each leg amputation.

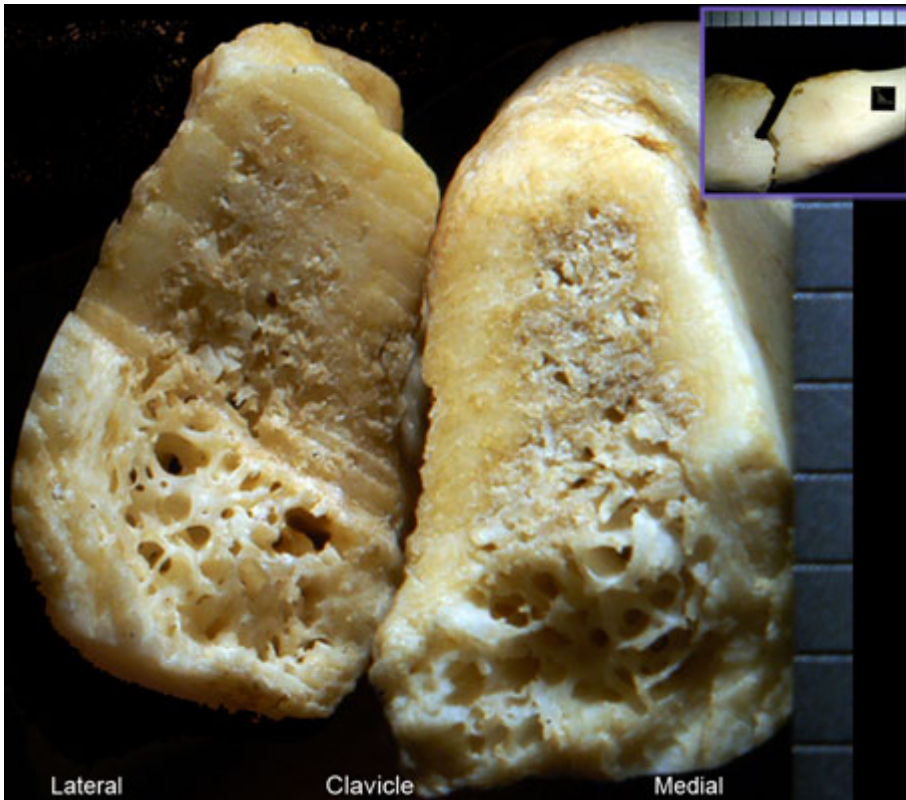

Figure II-12. Clavicle: right and left kerf walls are dissimilar due to asymmetrical saw blade sets.

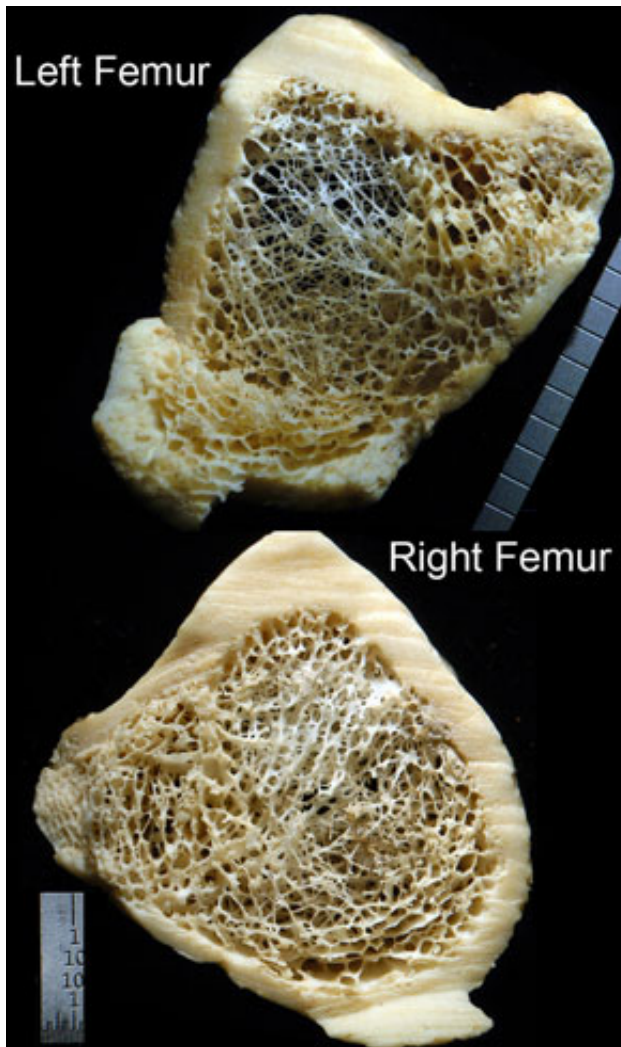

Figure III-13. This illustrates how right and left femora proximal cut walls have dissimilar appearances. This could be diagnosed as two saws or a saw blade with side differences. In this case it was a blade with pronounced set to the left, and essentially no set to the right.

Blade and Tooth Shape

Their shape further describes saws. Shape refers to the angle in which the teeth are filed; the tooth shape as it was designed in the saw blade; and the contour or flexibility of the blade.

Rip or Crosscut Saws

The most common classification of saws in terms of tooth shape is the rip and crosscut saw (Figure III-7). These styles are important in that each function in a different manner to effectively cut different types of material.

Rip saws are designed to cut in a chiseling fashion, where each tooth chisels a bite and ejects it at the end of the stroke (Figure III-14). Rip saw teeth are filed at a flat angle to form a flat chiseled face. Large toothed saws with rip teeth are designed for cutting with the grain of wood (Cunningham and Holtrop 1974:82, Lanz 1985). The front of rip teeth project from the blade to form a raker angle of 90 degrees (perpendicular to the plane of the teeth), then trails off to the back side of the tooth and forms a gullet angle of about 60 degrees with the front of the next tooth. The rip design cuts material quickly and roughly. For a smoother rip cut, the teeth may be tilted back as much as 8 degrees, but this design cuts less material with each stroke. Most saws used in this study have rip-style teeth. As one would assume, the higher the number of teeth per inch teeth, then these teeth become too small to file.

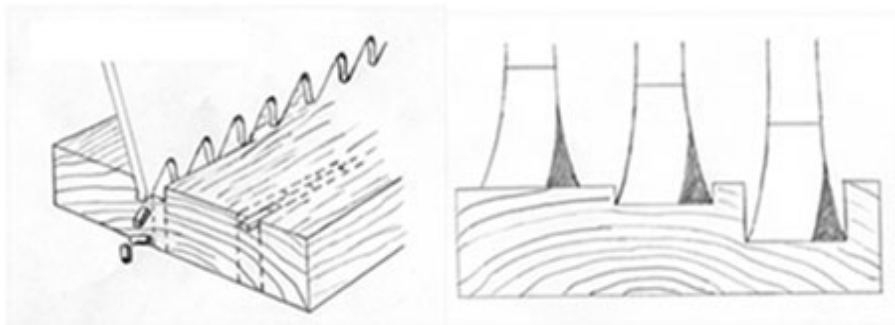

Figure II-14. Rip saws: each tooth chisels a bite with the grain. (Source: Cunningham, BM and WF Holtrop, 1974 Woodshop Tool Maintenance. Peoria: Chas. A. Bennett Co., Inc., P 74)

Crosscut saws, as the name implies, are designed for cutting across the grain of wood. Crosscut teeth are smaller and bite less material, as the teeth are rotated back 15 degrees. Therefore, crosscut teeth are often the same shape as rip teeth, but the front side of the tooth is noticeably sloped back (actually rotated) on the blade, rather than aligned perpendicularly to the blade as seen with rip teeth. Crosscut teeth are filed on the cutting edge at about a 60 to 75 degree angle. The front of each tooth is similar to a knife edge and forms a needle point, rather than a chisel (Jackson and Day 1978:76, Nagyszalanczy 2003). Each tooth progresses through wood fibers with a sharp edge, and slices the instead of chiseling blocks it (Figure II-15). With recent mass production of saws, a new problem has come to light. Many saws are labeled as 'crosscut' while in fact they lack filed teeth.

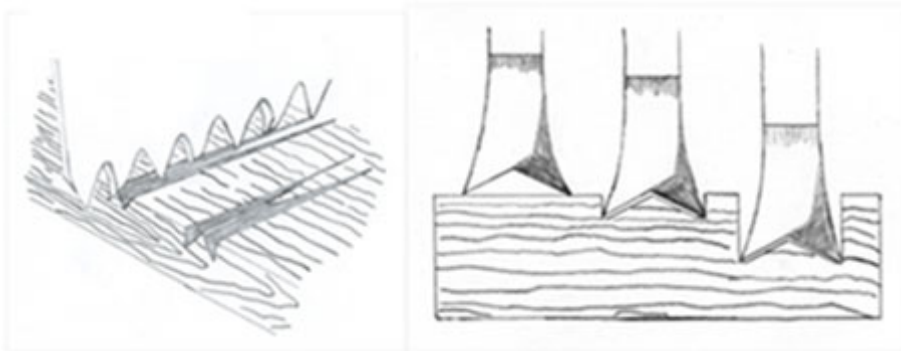

Figure II-15. Crosscut saws: cut across the grain and slice fibers of wood. (Source: Cunningham, BM and WF Holtrop, 1974 Woodshop Tool Maintenance. Peoria: Chas. A. Bennett Co., Inc., P 74)

Push/Pull Saws

Another common variation in tooth shape is the peg toothed design, where the tooth is sloped at 45 degrees. The gullet angle has to also be at 45 degrees, so that in both directions, the teeth produce an identical bite. The peg tooth design with a concurrent gullet angle (Figure III-16) has been termed a "push/pull" saw.



Figure II-16. Push/pull, or a two person tree saw.

Sometimes, different shaped teeth are placed on the same blade so as to enhance a particular type of cut. For example, pruning saws may have raker teeth inserted into a

bank of crosscut teeth. Since this type of saw is designed to quickly cut soft wood logs, the teeth and gullets are often large enough to accommodate the sawdust. The crosscut teeth make the cut, while the raker teeth clean out the kerf. In large saws, raker teeth are generally rip filed and short so that they only chisel the high points of the kerf floor while the crosscut teeth are cutting.

Tooth and blade shape also determinants as to whether a saw is to cut on the push or pull stroke. Historically, the Western hand saw has a more powerful push stroke (Figure III-7). Likewise, Continuous cutting – not reciprocating - power saws have teeth designed to cut only on the front side of the tooth.

A major exception to the push designed saw is the Japanese pull saw. The Japanese have retained and perfected designs of pull saws (Figure III-17) to the point of producing a saw quite different from that of Western saws (Schwarz 2006). Because of the force being exerted on the pull, tension can be maintained even on very thin blades. Since they do not need to be ductile on the push stroke, Japanese saws utilize a more hardened metal (Rockwell Hardness Rc 54) than their Western counterparts. Thus, these saws are more brittle and are more likely to break teeth or blades. The narrower blade with a minimal set of hardened teeth creates a narrower kerf. Therefore, the pull saw wastes less wood and demands far less effort for the same job (Lanz 1985:13-17; Schwarz 2006). The push stroke is a more accurate and efficient action than the pull stroke.

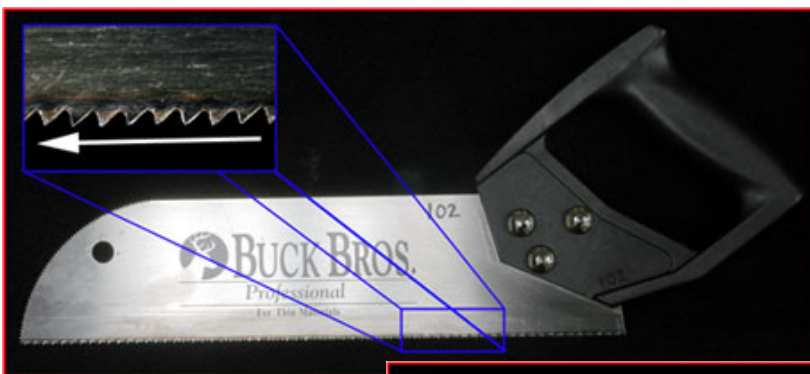
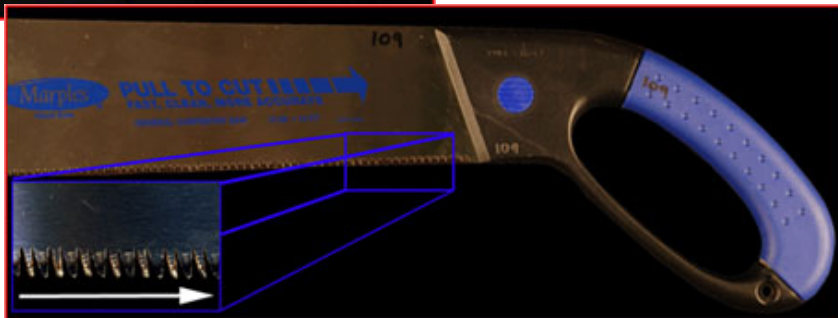

Figure III-17. Push stroke (Western) saw.

Figure III-18. Pull stroke (Japanese) saw.



Other exceptions to push stroke saws are some pruning saws – as it is easier to pull than push when in awkward positions or out on a (tree) limb; buck saws, which may have a push and pull stroke for a person on each end of the saw; (Figure III-16), and power reciprocating saw blades, which cuts on the pull stroke to avoid blade bending and binding during high speed reciprocating motions. Flexible saws generally cut in either direction as do the reciprocating (vibrating) autopsy saw.

Chain saws have a completely different type of tooth shape design. Chain saws are designed to cut soft material at high speeds. When cutting hard material like bone, these chain saws create wavy edged walls, but the teeth bite very little into the bone. Because of the hardness of bone and the basic design of the chainsaw, with a tooth in the shape of a “J” (Figure III-19), this particular saw action appears to “melt” the bone while beating it into submission (Figure III-20).

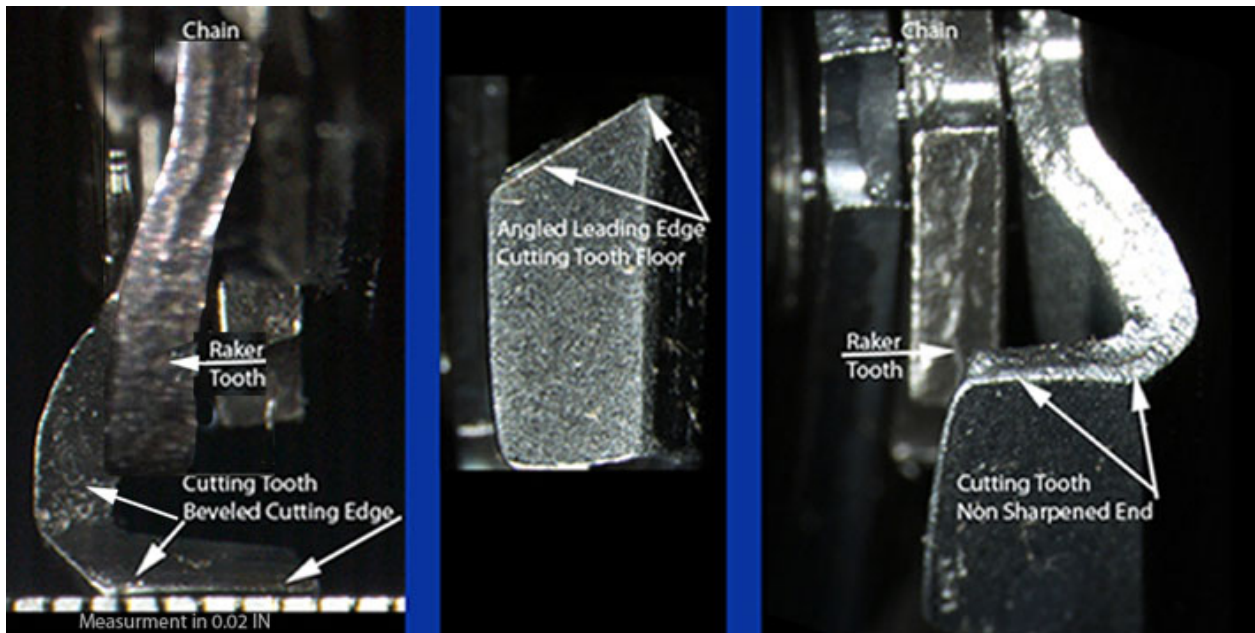

Figure III-19. Three different views of chainsaw cutting teeth. Also note raker teeth and the body of the chain. Notice the beveled cutting edge of the leading edge of the tooth, as opposed to the non-sharpened end, including the horizontal and vertical aspect of the tooth.



Figure III-20. This illustrates two different views of chainsaw dismemberment cuts to a femur. You see the “J”-shaped tooth “beating” the bone the blade bounces back and forth with the introduction of each tooth.

Saw Blade Flexibility/Contour

Saw blade shape and the method of delivery of the teeth to a surface are also characteristics that may be used to identify saw marks. While most blades are designed to propel teeth in a straight line, some saw blades are arched or flexible (Figure III-21). How saw teeth are introduced into the material (e.g., bone, wood) may influence the residual characteristics that could leave striae which resemble blade shape or the shape of the material.

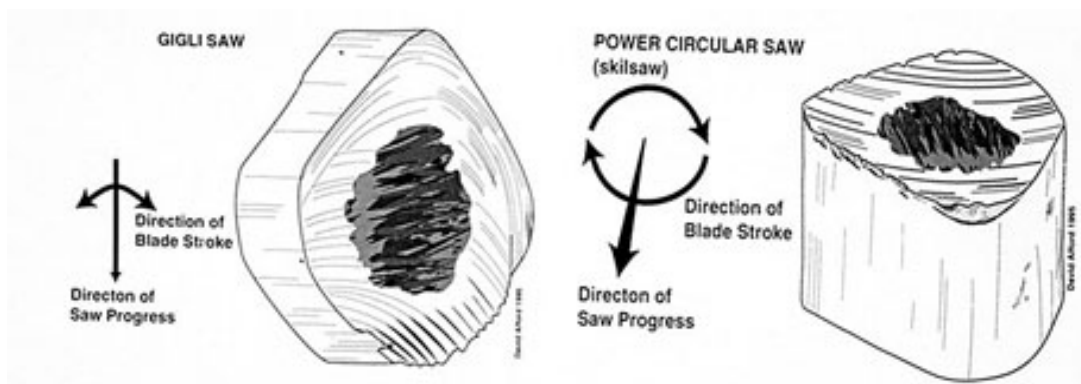

Figure III-21. Two types of ‘shaped’ saw cuts. The Gigli saw is a flexible saw that wraps around the bone as it cuts, with striae mimicking the convex bone shape. The power circular saw bends into the bone, creating fixed radius concave striae.

Saw Power

Obvious differences exist with regard to the power mechanism of a saw. Throughout history, saws have been physically powered by the person(s) utilizing the machine. Human power varies in speed and strength, as well as in handedness and skill. Mechanically powered saws refer mainly to gas, electric, or pneumatic powered tools that reduce human variation from the sawed byproduct, while adding speed and uniformity. Power saws are designed to cut in a reciprocating or continuous motion and may be supported by a frame or hand held. In the forensic setting, power saws have recently become more common than in the past due to mass production of lower quality and lower priced power saws that are designed for private use. Many dismemberment and mutilation cases are routinely misinterpreted to have been result of a mechanically powered saw, when in fact, a hand powered saws had been used. (Symes et al. 2007).

Since a mechanically powered saw cuts with more force and speed, the blades are manufactured to withstand a higher amount of stress. Exceptions are found when the blade is supported in a frame like a band saw, or the blade has little movement like a cast/autopsy saw. Saw power is generally indicated by uniformity of cut (Figure III-22 left image), transfer of energy, and material waste (Figure III-23). A mechanical power source has a greater influence on the saw and the sawed by-product. Principles of sawing rely on blade and tooth design, and also the manner in which energy is transferred to the blade and the material. Increased speed and torque of power saws dictate their tooth design. High cutting speed combined with the potential pressure applied by the operator, requires the design of short, wide teeth, and/or a robustly supported blade. Power saws commonly cut faster but, unless heavily supported, tend to waste more material. In a high energy situation, there is an increased demand on the saw teeth. Therefore, power saws rarely utilize filed tooth saw blades (crosscut), as the needle tipped saw teeth associated with these blades would distort under pressure. However, with a new design of hardened tooth tips, examples of crosscut power saw blades are available.

Circular saws commonly have carbide tipped teeth with a design that may leave kerf floors resembling a filed toothed saw ('W' shaped Kerf floor). A final characteristic that may be visible in power saws is the tendency for the operator to start a new kerf instead of placing the saw back into the former kerf. In Figure III-24, the top image has three

deep false starts that are regular and straight edged. This image represents the same power reciprocating saw that was used in both Figure III-22 (left image) and Figure III-23. Repeated deep false starts are closer to each other and are more indicative of a power saw. Figure III-25 illustrates more examples of false starts in a femur and a lumbar dismemberment. It would appear the saw was limited in gutting ability for deep cuts. This likely indicates a short blade or a blade not designed of deep cuts. In this case it was a 7-1/4 inch circular saw blade designed for little more than two inch cutting penetration. Figure III-25 has an unusual pattern of five parallel deep false starts. While the environment has all but obliterated the saw cut striations, these deep, uniform cuts, some within 1-2 millimeters of completion, could not have been made with a hand powered saw without fractures the shaft.

Hand powered saws are characterized by the inverse of what is visible in mechanically power saws. High energy is not visible, there is a lack of uniformity, thinner blades are used, and there are often indications of the perpetrators arm movement. Arm movement creates nonparallel striations that frequently change direction with rocking motions (Figure II-22 right image). A hand saw discourages deep false starts, as it is too much to start another deep cut over. Deep false starts are likely to be products of a powered saw.

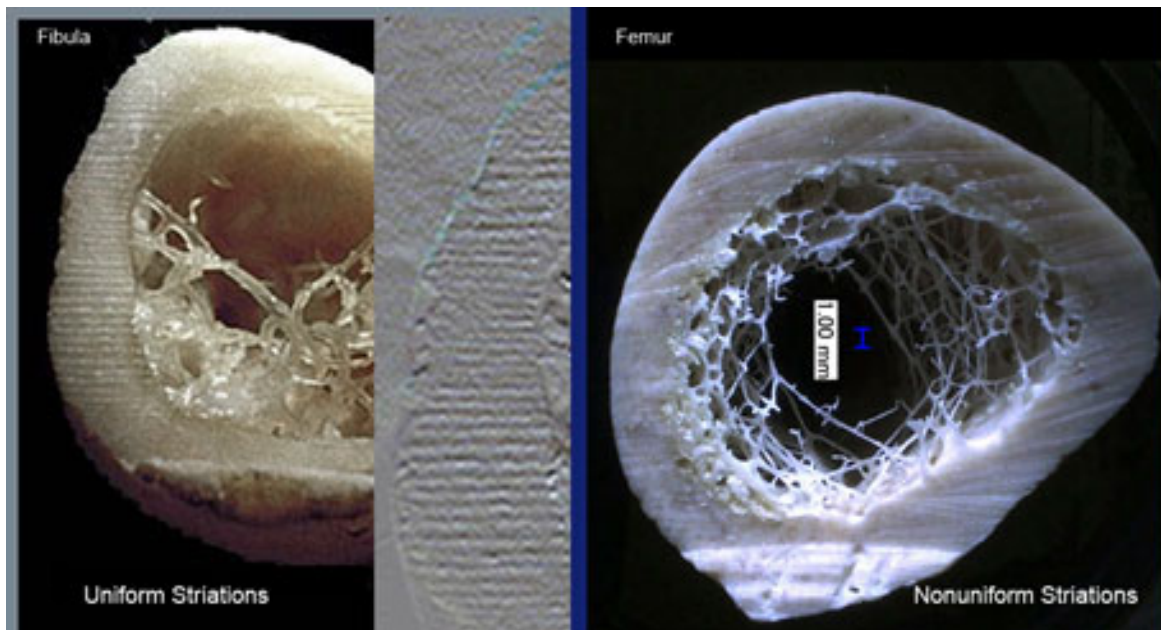

Figure III-22. A cut fibula where the striations demonstrate a uniformity of cut on the bone and visible also in the embossed enlargement. The femur shows irregular striations from a hand saw.

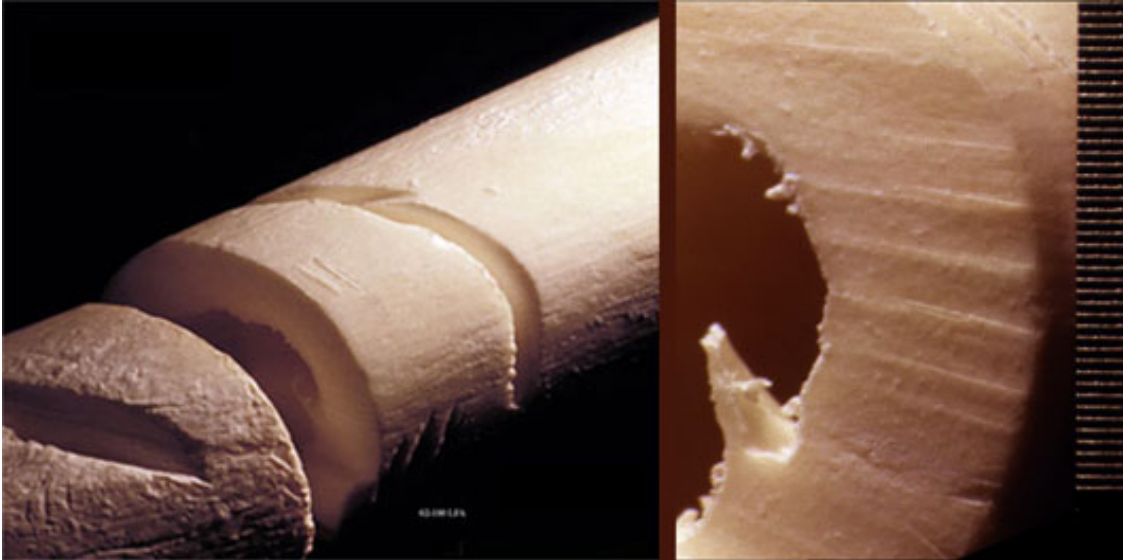

Figure III-23. Numerous false starts cuts and a kerf wall on the femur. The kerf width is wide and all cuts are extremely uniform and smooth. The smooth walls make it difficult to see each tooth striation; rather only passive stroke striations are visible (right Image). These defects are classified as reciprocating cuts from a power saw.

Direction of Saw Motion

Establishing saw cut direction from cuts on bone is feasible and contributes to crime scene investigation. However, "direction" may be misleading, unless it is clearly defined. Direction of cut indicates two separate saw actions; the direction of blade progress, and the direction of blade stroke (Figures III-9 and III-26). Indicators of direction of saw progress can be determined from the false start and breakaway spur. False starts, where individual teeth strike and chisel material, or where actual kerfs are abandoned for another cut, commonly produce initial cuts. The plane formed between the false start and the breakaway spur or notch usually gives the precise direction of saw progress.

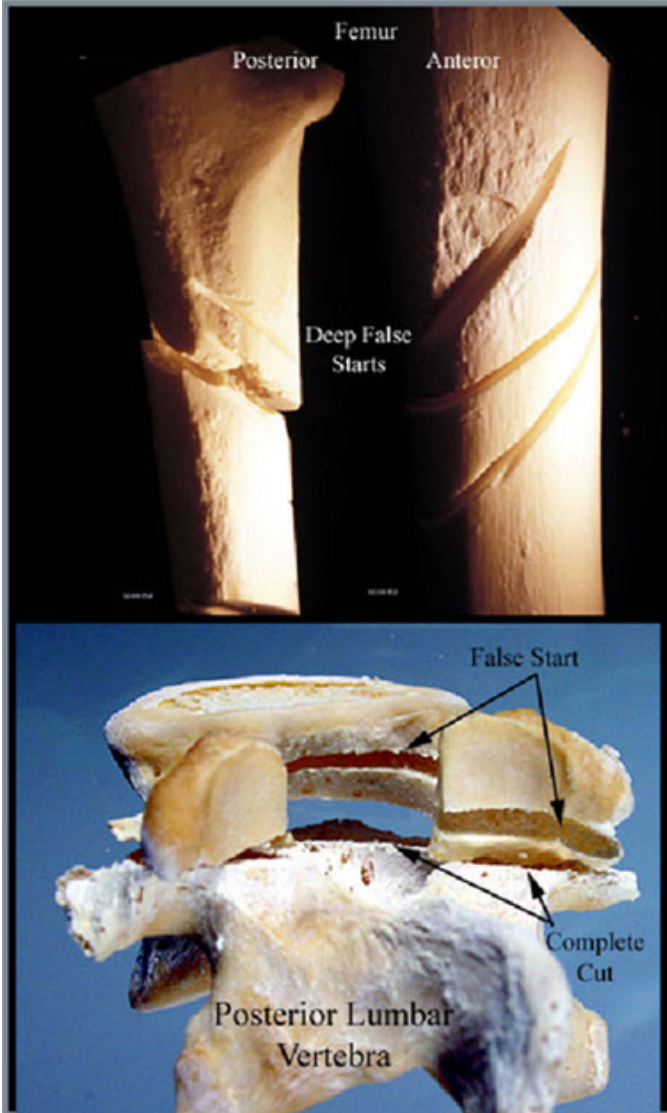

Figure III-24. Numerous false start cuts are present on both femoral shafts. Deep false starts on the 5th lumbar vertebrae are a common place for dismemberment. The kerf width is somewhat wide and all cuts are extremely uniform and smooth, such that it is difficult to see the striae.

Figure III-25. Two views of numerous identical false starts, which are too uniform for a hand saw.



Direction of saw stroke is simply the direction of the tooth as it cuts or shaves the bone, or essentially the direction of the residual striations. As mentioned above, many saws are designed to cut in one direction. If the saw is used in a reciprocating motion, there is a cutting stroke and a passive stroke. Teeth exiting the bone on the power stroke generally produce exit chipping (Figures III-9 and III-26), while passive strokes generally leave no exit chipping. The direction of the cutting and passive strokes is essentially the direction of the residual striations in the bone. Direction of blade stroke (tooth striae) is essentially perpendicular to blade progress.

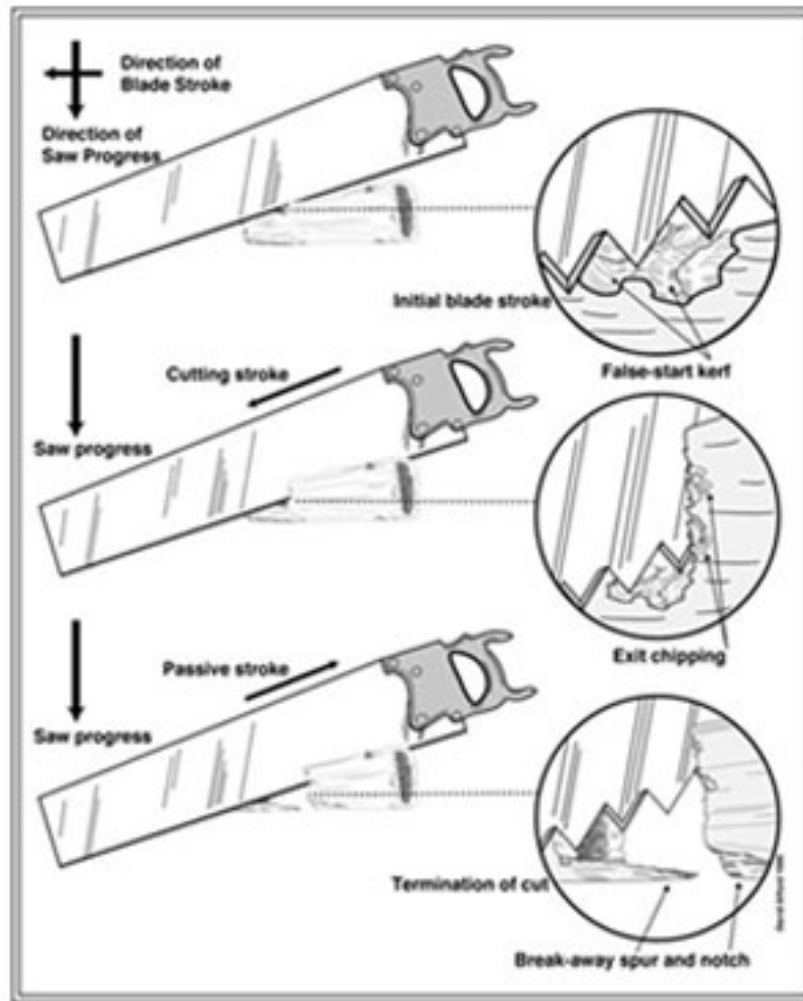

Figure III-26. Forming a kerf with the cutting stroke and passive strokes demonstrated and exit chipping highlighted.

Figure III-27 illustrates a proper documentation of the cut surface of bone. Analysis has indicated direction of saw progress and stroke.

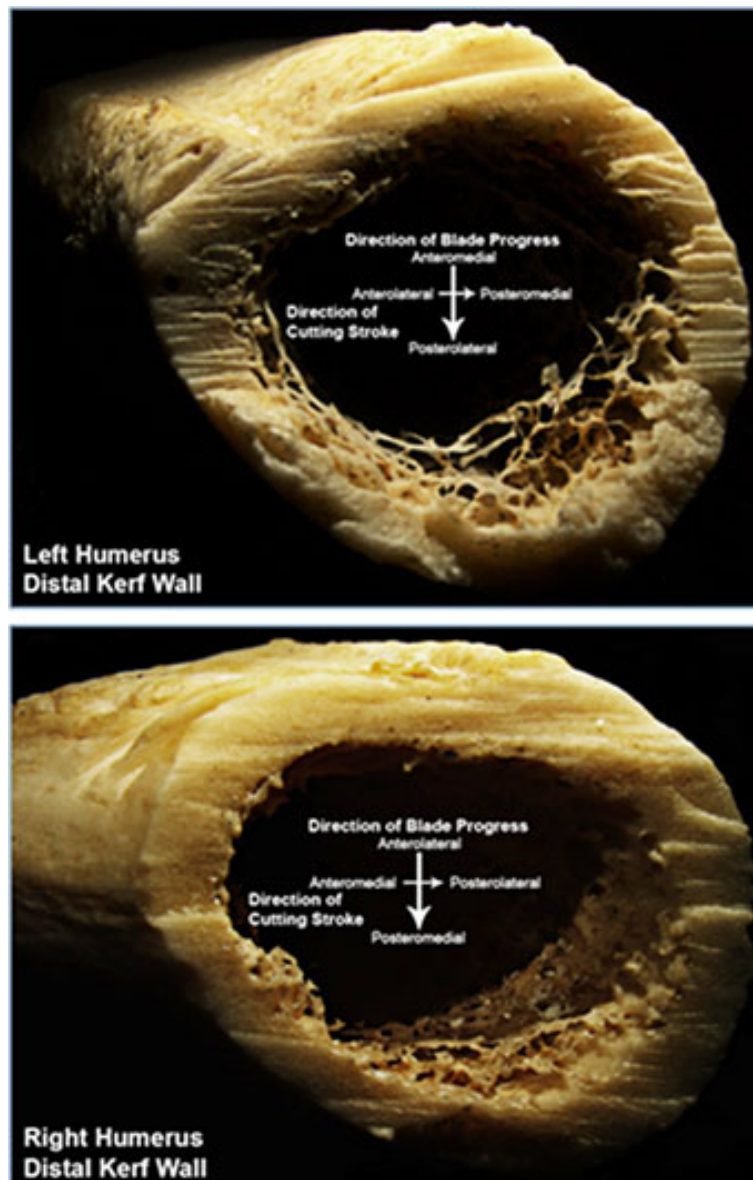

Figure III-27. Humeral cuts as in Figure III-3, but now labeled with small arrow showing the direction of saw stroke (striae) and large arrow showing saw progress (false start to break-away).

Introduction to Saw Mark Analysis Characteristics

Each definition is provided with the location in which to observe this feature(s) on a saw cut. Locations include, kerf floor (KF), kerf wall (KW), break-away spur (BA), or false start (FS).

Kerf

The kerf is described as the walls and floor of a cut (Figures III-9 and III-26). Floors are expressed in false-starts and occasionally in break-away spurs. Kerf floors (KF), when present, offer the most information about the points of each tooth, the relationship of the points to each other or the set (lateral bending) and number of teeth per inch (TPI). Kerf walls (KW) can also offer information about teeth per inch, saw power, and direction of cut.

Break-Away Spur

The break-away spur (BS) is a projection of uncut bone at the terminal end of the cut after the force breaks the remaining tissue. This commonly occurs on the stable end of the bone (Figures III-9 and III-26). The break-away spur is often diagnostic for residual kerf floors. The size of the spur often depends on the amount force applied across the bone, which also results in a fracture of that bone. For instance, the weight of a handheld circular power saw or chain saw often produces a large break-away spur if any additional force is applied to the bone when cutting.

False Starts

False start (FS) kerfs are cuts that did not completely separate bone into two halves. A false start is composed of two initial corners, two walls, two floor corners, and a floor (Figure III-9). False start cuts are not considered 'hesitation' marks and are not termed as such (see below).

Traits and Characteristics Associated with Saw Size, Set, Shape

Minimum Kerf Width - is a measurement of the width of the kerf. Minimum kerf width is directly related to the width of the set of the blade (Figure III-28).

Teeth Per Inch (TPI) - is a measure of the number of complete (not just points) teeth per inch. There is one more point per inch (PPI) than there are teeth per inch (Figure III-7 and III-10).

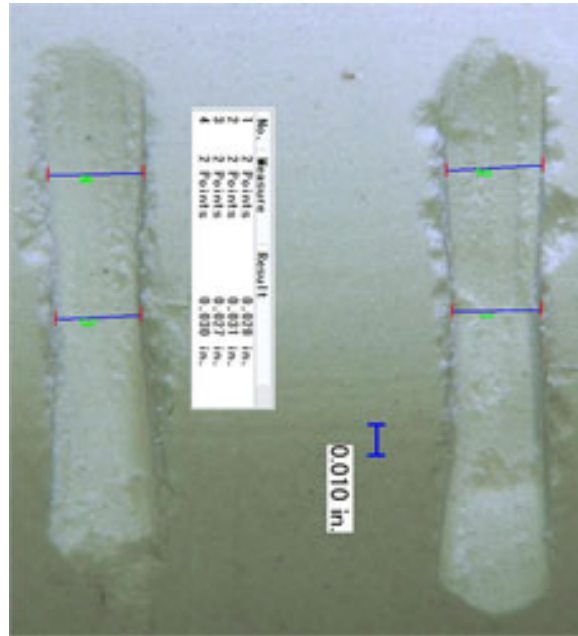

Figure III-28. Minimum kerf width measurement of saw mark in chalk.

Tooth Hop– refers to striae across the face of the bone that generally progress in a straight pattern. With close observation, the residual kerfs (striations) occasionally show patterned hopping or predictable waves. Blade hopping is created as teeth begin to enter the kerf and each successive tooth strikes bone, which produces movement of the whole blade. Measuring from peak to peak or dip-to-dip of each wave indicates the distance between teeth on the saw. It has been demonstrated that tooth hop can occur with a variety of saws and accurately indicates spacing of saw teeth (Andahl 1978; Symes 1992) (Figure III-29). (KW)

Pull Out Striae-(Tooth Scratch) - involves the presence of perpendicular striae on the cut surface of the bone. When the saw is withdrawn from the kerf in mid-stroke, the blade creates striations on the cut surface. Bonte (1975:319) recognized pull out striae as appearing “vertical to the sawing level which extend[s] over several saw marks . . . [and] corresponds, with normally set saws, to twice the distance between the teeth.” Unfortunately, the phrase “normally set saws” is a misleading one. Alternating set saws

can leave this type of pattern, but a saw with a raker set (See Saw Set below) may leave striae that represent the distance of three rather than two teeth. Occasionally, all the teeth may leave residual marks when the blade is removed. Pull out striae are characteristics that do not easily stand alone and are most useful when used to corroborate other - more reliable - estimations of tooth distance. (Figure III-30). (KW)

Tooth Imprint and Floor Dip - are the result of combined saw tooth actions that cut a kerf floor in bone. When the floor of the kerf is examined on end, the seemingly flat-bottomed kerf may actually be notched or wavy. Tooth imprints and floor dip are residual imprints from tooth points in the kerf floor created after a saw is interrupted in the cutting stroke. Consecutive tooth imprint features can be measured in false starts and break-away spurs to represent the distance between teeth, indicate the set (shape) of the blade and indicate the shape of the individual tooth. (Andahl 1978:36-37; Symes 1992) (Figure III-31). (KF)

Saw Tooth Width- is calculated in two ways: 1. measurement of floor patterns and 2. measurement of residual tooth trough. Floor patterns give an average estimation of saw tooth width while the residual tooth image, if properly interpreted, produces an accurate image of an the tooth. (KF)

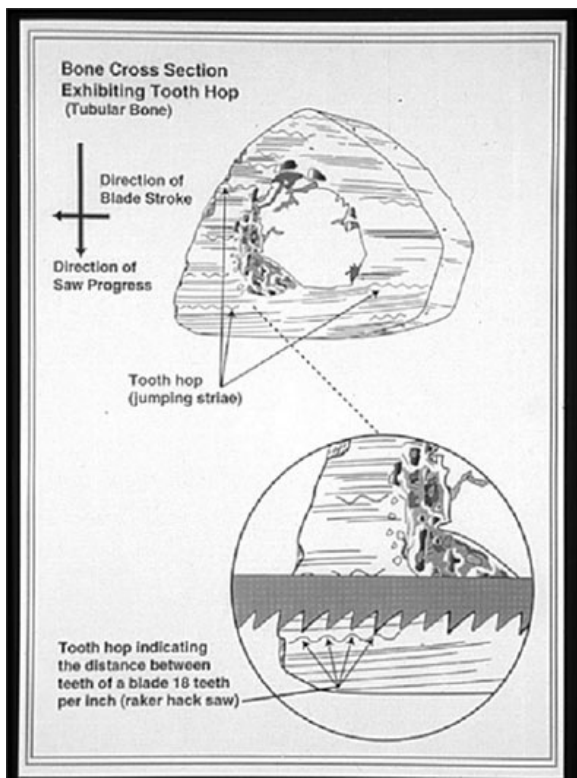

Figure II-29. Tooth hop: peak to peak or valley to valley represent distance between two teeth.



Figure III-30. Pull out striae. Where in the plane of the cut may indicate two or three teeth distances.

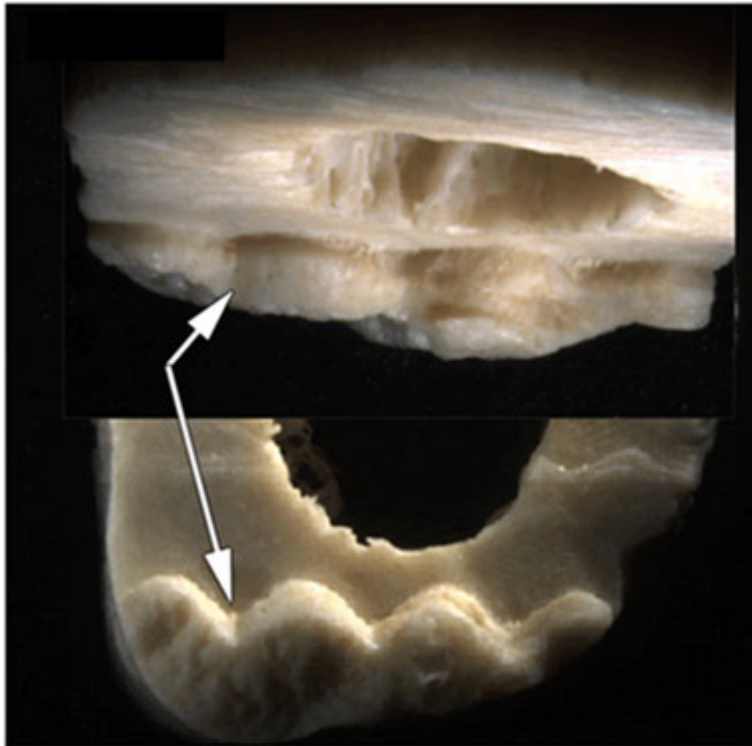

Figure III-31. Floor (top) and wall (bottom) views of tooth imprints (arrows) and floor dip, represent residual imprints from tooth points in the kerf floor created after a saw is interrupted in the cutting stroke. Each is important for indications of TPI. This was a 5 TIP (TPI) toothed saw with large gullets, so the features are accentuated.

Saw tooth set is used to describe the lateral bend of teeth. Three major types exist namely, alternating, raker, and wavy (Figure III-11). A cheaper blade may have no set, especially if there is no lateral bend to the teeth.

Blade Drift refers to the pattern of teeth drifting across a kerf floor; where every tooth that enters the material creates a directional change in the blade. Blade drift is most evident in shallow cuts produced by alternating set saws (Figures III-32 and III-33).

In order to understand this motion, one needs to examine the action of a single tooth, and then combine this action with the actions of consecutive teeth. As a single set tooth enters the material, the tooth seeks an orientation parallel to the direction of the blade and to the midline of the material. This midline orientation is compromised as the next tooth enters the material. The second tooth is alternately set to the first tooth and therefore enters the material from a position opposite the previous tooth and seeks a different midline from the first tooth. Therefore, the second tooth actually attempts to cross the path left by the first tooth (Figures III-32 and III-33).

While the second tooth is pulled to the midline, the first tooth is sent in a direction parallel to the second tooth; this continues until a compromise is reached between the two teeth. Parallel drift is reversed each time a new tooth enters the material, with new teeth essentially entering the same two patterns and approximately the same grooves. This continual seeking of midline with intermittent introduction of opposite set teeth creates a fluctuating pattern in superficial cuts, resembling a chain of 'figure 8s.' Thus a very predictable pattern is established since there are essentially two rows of teeth set in an alternating pattern.

Once the blade is immersed in the material, much of the drift is suppressed. Drift patterns are most noticeable at the beginning or end of a cut in a tubular bone since there is little material to offer resistance or trap the blade's motion.

Harmonics- are described as peaks and valleys that are exhibited three-dimensionally in bone cross sections (Symes 1992). Harmonic oscillations are found to exist in nearly all blades with alternating set teeth, and are the direct result of normal cutting action in hand and mechanically powered saws. *Harmonics are simply the side view expression*

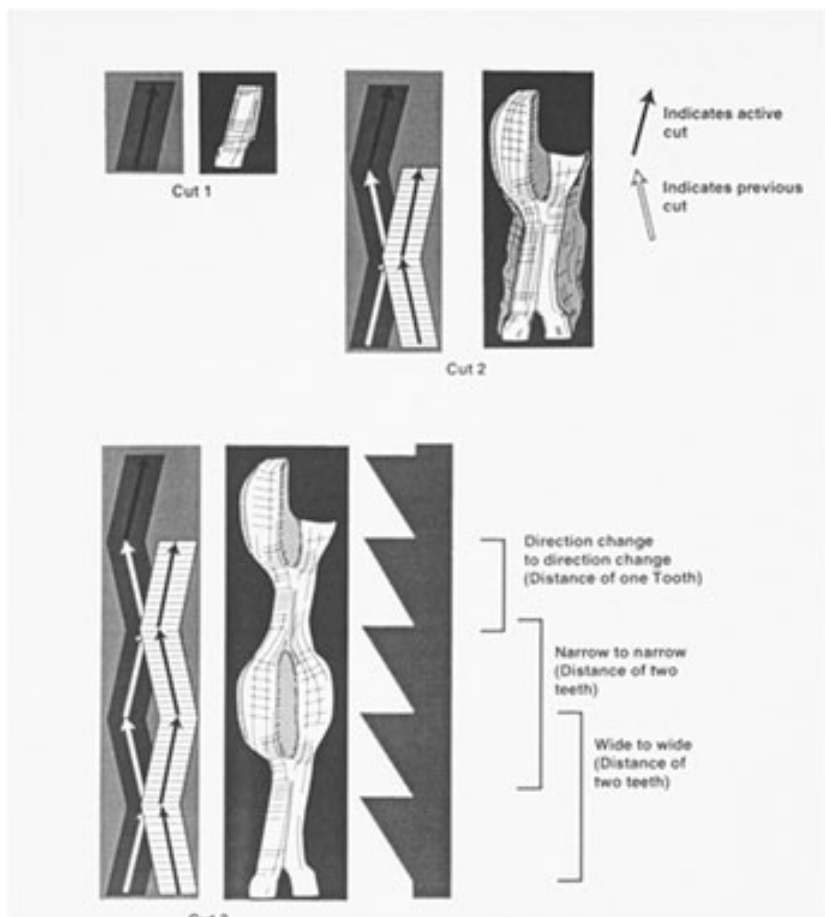

of blade drift and are good indicative characteristics of blade set and TPI (Figures III-34). (KW)

Figure III-32. Pattern of teeth drifting across the kerf floor. Every tooth entering the material creates a direction change an important characteristic for indications of TPI.

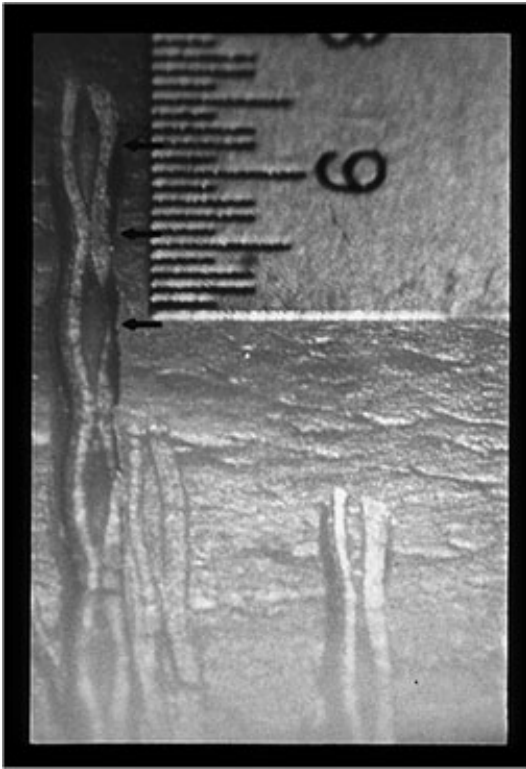

Figure III-33. Kerf demonstrating blade drift (in this case, direction change to direction change). Distance (arrows) is about 0.11 in making TPI in the blade about 0.09 in (see Table III-3).

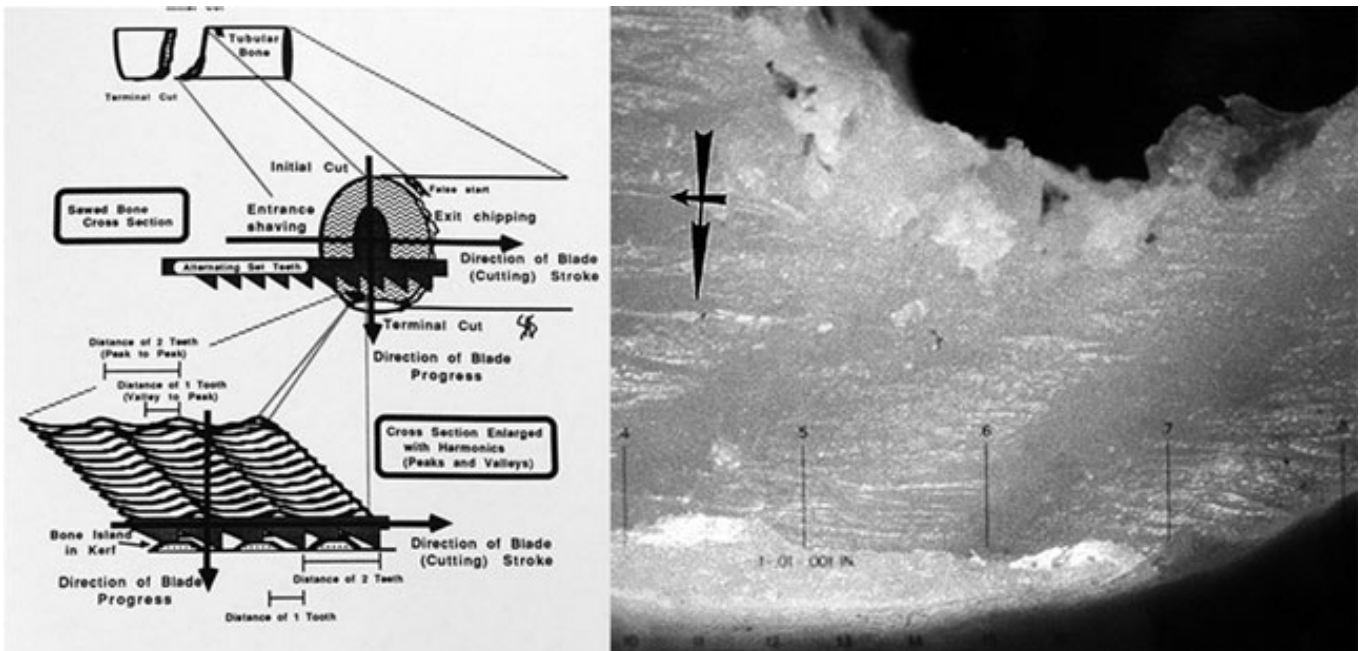

Figure III-34. Actual kerf demonstrating harmonics of an alternating set saw blade. Harmonics are essentially blade drift observed from the side, where the introduction of each tooth forces lateral movement of the saw blade. This lateral movement is indicated by peaks and valleys on the wall of the cut. Harmonics are indicative of blade set and TPI where peak to peak, or valley to valley, is the distance between two teeth. (Original Figures from Symes 1992.)

Bone Islands - are characteristic of alternating set blades and blade drift. A wider set increases blade drift and leaves material in the midline of the kerf, or an island at the wide part of the 'figure 8.' (KF) (Figure III-33).

Shape applies to the contour of the blade, the tooth as it is cut out of the saw blade, and whether or not the teeth are filed at an angle. The most common classifications are rip and crosscut saws (Figure III-7). These styles are important in that each functions differently so as to effectively cut a desired material.

Contour

Flat- Typical straight blades, inclusive of both hand and mechanically powered saws; produces a flat-bottomed kerf. (KF)

Curved- Curved blades (such as circular saws, autopsy blades, and curved pruning saws) and flexible blades (such as gigli saws) leave a residual curved kerf floor. (KF)

Tooth Orientation

Tooth orientation is diagnosed with the direction of sawing motion. The confluence of features visible in analyzing saw direction allows for the determination as to whether a blade's power stroke is occurring on the push or the pull.

Push Saw- A typical "Western" saw cuts on the push stroke (Schwartz 2006). It has a wider blade and produces more material waste, which, in turn, creates a wider kerf. In general, push saws have larger teeth and the push stroke is more powerful, which gives the cuts a more accurate and efficient action than with a pull saw (Figure III-17).

Pull Saw- A Japanese pull saw cuts on the pull stroke. Blade design is thin with aggressive teeth. Despite the awkward pull stroke, this saw is very efficient as the thin teeth cut less material and create less waste (Figure III-18).

Rip- Rip saw teeth are not angled or filed. The teeth are simply notched out of the blade. As such, these saws essentially chisel material, rather than cut it. Rip saws are designed to cut with the grain of wood (Figure III-7).

Crosscut- A crosscut saw has teeth that have been filed to an angle, usually producing a point. The filing allows each tooth to act as a tiny blade, which cuts through material. Crosscut saws are designed to cut across (or through) the grain of wood. (Figure III-7).

Traits and Characteristics Associated with Saw Power (Hand vs. Mechanical)

Separating hand powered from mechanically powered saws is approached in the examination of three characteristics; consistency of cut, energy transfer, and material waste. These characteristics are greater with mechanically powered saws (Figures III-21, III-22, and III-23).

Consistency of Cut

Consistency of cut is anticipated in continuous cutting power saws; where the blade continuously cuts material at high speeds. However, this consistency is evident in all power saws, even those with reciprocating actions. Consistency refers to recognizable

patterning, with a gradual change in patterns. Hand powered saws typically exhibit an inconsistency in cut that is evident on the kerf wall. (KW)

Energy Transfer

Mechanically powered saws increase energy transfer to cut bone and usually create more polish on the cut surface. Increased tooth speed, saw weight, and torque lead to a tendency to inadvertently discontinue a cut. Because of the ease of the cut, it is not important to reinsert the blade in the kerf that was initially started. The opposite tendency is true in hand powered saws as it is more efficient to reinsert the blade in the false start to continue the cut. (FS)

Material Waste

Power saws are generally characterized as wasteful of material. This may be credited to the stout blade design or the “ease” of producing a cut (Figure 21, 22, and 23). Since power saw cuts are produced with little expansion of human energy; it is likely that more cuts are produced and more material is wasted. Power saws, which lack large teeth or thick blades, must be supported (i.e. band saw). (FS)

Traits and Characteristics Associated with the Saw Direction

Cutting/Passive Stroke

Cutting stroke is either a continuous action in a single direction or a reciprocating action that produces the majority of the cut. If an equal force is applied to a reciprocating blade, the direction of stroke cutting or chiseling of bone is also the direction of the cutting stroke. This is usually due to the design (slant) of the teeth.

A passive stroke occurs in reciprocating saws where the lack of an aggressive tilt in the saw teeth allows them to slide across the bone without leaving more than a single striation (Figure III-I-22 and III-27).

Blade Progress

Indicators of direction of saw progress center on the false start and break away spur. False starts, where individual teeth strike and incise material or where actual kerfs are abandoned for another cut commonly accompanies initial cuts. The plane formed between the false start and the break-away spur or notch gives the precise direction of saw progress. Direction of blade progress is perpendicular to stroke and tooth striae (Figures III-9 and III-26).

Entrance Shaving-As the saw enters the side of the bone; the blade can shave the bone entrance and give it a polished and scalloped appearance. Shaving can be a consequence of twisting of the saw such that the blade is not allowed a direct path into the kerf. More often it is simply due to the tooth set being wider than the blade, which forces each tooth to cut a kerf. Seldom is there chipping as the tooth enters the bone, and if present, it is difficult to observe. (KW)

Exit Chipping-Exit chipping is present with few exceptions. Exit chipping occurs at the end of the cutting stroke or on the side of the stroke emphasized by the individual sawing. As a rule, the largest chips of bone are removed on the cutting stroke as the blade exits the bone (Figures III-9 and III-26). (KW)

Kerf Flare - If kerf flaring occurs on one end of the kerf floor, it indicates the 'handle-end' of the blade. It expresses the increased movement of the flexible blade as it continually enters the kerf. The opposite end of the kerf floor does not exhibit a flare (Figure III-35).



Figure III-35. False start: flare at one end. This suggests the end of the kerf where flexible saw blade is flared due to lateral movement of the handle, while the blade supported by the kerf does not flare.

Saw Mark Analysis Flow Chart

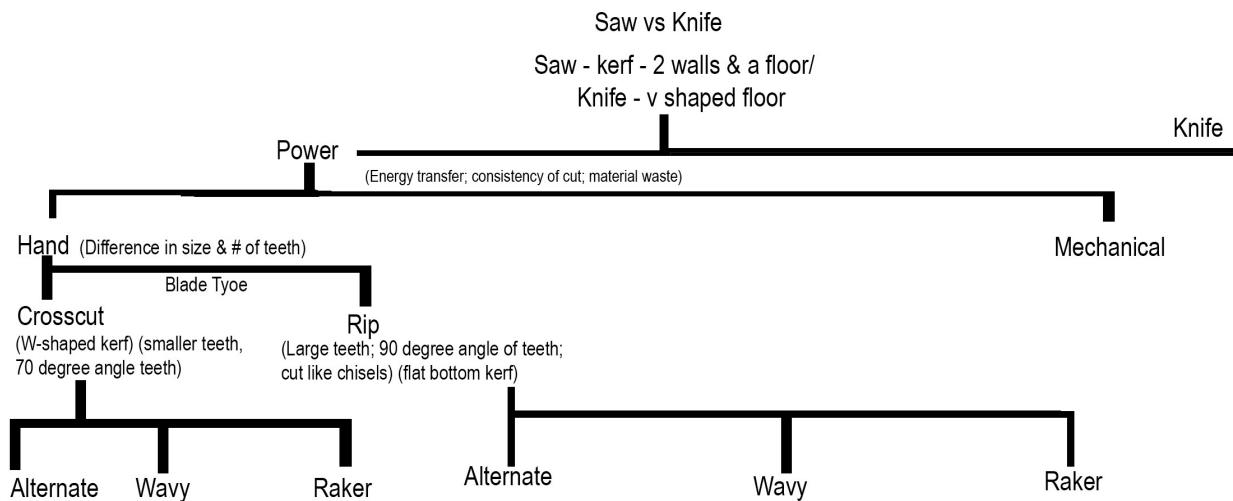

Saw Mark Data Collection Sheet

Steven A. Symes

General Information

Examination Date: _____ Case No: _____

Case Description: _____ Bone: _____

Cut Location: _____ inches from Proximal/ Distal end
(circle one) Total # Cut Surfaces: _____

Orientation of Cut to Bone: Transverse [Proximal _____ to _____ Distal]
APLM APLM

Notes:

General Traits and Characteristics

Break away Spur: _____

Break away Notch: _____

Direction of Blade Progress: False Starts _____ to _____ B-A spur/notch
APLM APLM

Direction of Cutting Stroke: Entrance Shaving _____ to _____ Exit Chipping
APLM APLM

False Starts: _____ # (if present): _____

Kerf Width Minimum: _____ Maximum: _____

Kerf Floor Shape W-Shaped: _____ Square bottom: _____

Characteristics – Analysis of Kerf Floor

Blade Drift: _____

Bone Islands: _____

Kerf Flare: _____ Description (if present): _____

Tooth Imprint: _____ #: _____ Measurement: _____
(if present) (consecutive imprints)

Floor Dip: _____ Description: _____

Characteristics – Analysis of Kerf Walls

Uniformity of Striations (consistency of cut)

Description: _____

Cut Surface Drift: _____ Description: _____

Energy Transfer: _____

Entrance Shaving: _____ Notes: _____
(See Direction of Cutting Stroke)

Exit Chipping: _____ Notes: _____
(See Direction of Cutting Stroke)

Harmonics: _____ Description: _____

Material Waste: _____

Patterned Striae Shuffle: _____

Polish: _____

Pull out Striae/ Tooth Scratch: _____ # of striations: _____

Measurements: _____ Avg. Measurement: _____

Tooth Hop: _____ # peaks/valleys (if present): _____

Measurements: _____ Avg. Measurement: _____
(Specify peak to peak or valley to valley)

Overall Power Description: _____

NOTES:

Saw Mark Diagnostics Form

Steven A. Symes

Examination Date: _____ Case No: _____

Case Description: _____ Bone: _____

Saw Size

Tooth Width _____

Based on: _____

Teeth Per Inch Calculation: _____

Based on: _____

Minimum Blade Width _____

Based on: _____

Saw Set

alternate _____ Alt/ isl _____ wavy _____

Based on: _____

Saw Shape

Rip(chisel) _____ Crosscut (cut) _____ Raker _____

Saw Power

Hand _____ Mechanical _____

Based on: _____

Direction of Motion

Push _____ Pull _____ Other _____ (explain)

Based on: _____

Reciprocating _____ Circular _____ Other _____ (explain)

Based on: _____

Additional Information

Guide for Data Collection Form

General Guidelines

- All measurements recorded in inches
- Record maximum amount of information possible (including written and photographic)
- Coding presence and absence of a trait or characteristic
 - 0 = Absent
 - 1 = Present

General Information Section

Examination Date: _____

Enter the date of initial examination of the cut bone (record subsequent examinations on additional data collection forms)

Case No: _____

Enter all case numbers related to the bone that is being examined

Case Description: _____

Describe the case (i.e. fresh dismemberment Smith – New Zealand)

Bone: _____

Give a brief description of the bone that is being examined (i.e. shaft left humerus)

Cut Location: _____ inches from Proximal/ Distal end
(circle one)

Description of the location of the cut. Estimate the approximate distance in inches from either the proximal or distal end. Circle either Proximal or Distal to indicate which end of the bone your approximation is was calculated. (i.e. Cut Location: 2.5 inches from the distal end)

Total # Cut Surfaces: _____

Record the total number of cuts exhibited on the bone specimen.

Orientation of Cut to Bone: Transverse [Proximal _____ to _____ Distal]
A P L M A P L M

Notes:

Enter any additional notes regarding the cut bone that is being examined.

General Traits and Characteristics

Break away Spur: _____

Enter 0= absent and 1= present. Note that the floor of a breakaway spur often gives information pertaining to the amount of force applied across the bone and it may show evidence of tooth imprint (representing the distance between teeth).

Break away Notch: _____

Enter 0= absent and 1= present. The size of the break away notch provides information pertaining to the amount of force applied across the bone.

Direction of Blade Progress: False Starts _____ to _____ B-A spur/notch APLM APLM

Saw progress is the plane formed between the false start and the break away spur or notch. APLM = Anterior, Posterior, Lateral, Medial. Enter the code in the blank that provides the best description of the progress of the saw. For example False Starts AL to PM B-A spur/notch which translates to False Starts Anterior Lateral to Posterior Medial B-A spur/notch. Meaning that the cut start on the anterior lateral area of the bone and was completed in the posterior medial area of the bone.

Direction of Cutting Stroke: Entrance Shaving _____ to _____ Exit Chipping APLM APLM

The cutting stroke is the continuous or reciprocating action that produces a majority of the cut. The direction of the cutting stroke is a way of describing (combined with the direction of blade progress) the position of the bone relative to the saw when it is being cut. For instance, the cutting stroke can tell us which side of the bone the handle is on (where the bone enters) and which side the saw blade exits on.

False Starts: _____ # (if present): _____

Enter 0= absent and 1= present. Also enter the total number of false starts that are identified on the bone surface. A high number of false starts may indicate a mechanically powered saw (used in combination with other characteristics.)

Kerf Width Minimum: _____ Maximum: _____

In inches, measure the area of the kerf that has the minimum and maximum width and record them here. Kerf width measurements should be taken in kerfs that are deep enough so that the teeth of the saw are well embedded in the kerf and unable to skip across the surface of the bone. If multiple kerfs meet these requirements they should all be measured and an average taken from them. Kerf width can be an indicator of hand versus mechanical powered saws.

Kerf Floor Shape W-Shaped: _____ Square bottom: _____

Check either w-shaped or square bottom kerf floor. W-shaped kerf floor indicates a crosscut saw and a square bottom kerf indicates a rip saw.

Characteristics – Analysis of Kerf Walls

Blade Drift: _____

Enter 0= absent and 1= present. All alternate set blades follow certain drift actions since saw teeth are set to produce a cut wider than the saw blade.

Bone Islands: _____

Enter 0= absent and 1= present. Bone islands are associated with alternating set blades and blade drift. A wider set increases blade drift and leaves material in the midline of the kerf.

Kerf Flare: _____ Description (if present): _____

Enter 0= absent and 1= present. Describe the location of the flare on the cut bone. For example, the kerf flare occurs on the anterior lateral portion of the cut right femur in a false start.

Tooth Imprint: _____ #: _____ Measurement: _____ (if present) (consecutive imprints)

Enter 0= absent and 1= present. Tooth imprints and floor dip are residual imprints from tooth points in the kerf floor created after a saw is interrupted in the cutting stroke. Enter the number of consecutive tooth imprints that are present. Measuring the distance between consecutive imprints represents the distance between teeth and gives clues to the shape of individual teeth.

Floor Dip: _____ Description: _____

Enter 0= absent and 1= present. Floor dip are residual imprints from tooth points in the kerf floor created after a saw is interrupted in the cutting stroke. Enter the number of consecutive tooth imprints that are present. Measuring the distance between consecutive imprints represents the distance between teeth and gives clues to the shape of individual teeth.

Characteristics – Analysis of Kerf Walls

Uniformity of Striations (consistency of cut)

Description: _____

Describe the cut surface in terms of uniformity of striations. Circular Saw – curving in the striations; Reciprocating Saw – linear striations

Cut Surface Drift _____

Enter 0= absent and 1= present. Cut surface drift is an irregular or wavy drift that is a fluctuation in the plane of cutting progress. These irregularities are produced by saw blades that progress through the material drifting one way then another into the material.

Energy Transfer _____

Enter 0= absent and 1= present. Mechanically powered saws increase energy transfer to cut bone. Increased tooth speed, saw weight, and torque lead to a tendency to discontinue a cut. Because of the ease of the cut, it is not important to reinsert the blade in the kerf that was

initially started. The opposite tendency is true in hand powered saws as it is more efficient to reinsert the blade in the false start.

Entrance Shaving: _____ Notes: _____
(See Direction of Cutting Stroke)

Enter 0= absent and 1= present. Describe the location of the entrance shaving in anatomical terms of the cut bone.

Exit Chipping: _____ Notes: _____
(See Direction of Cutting Stroke)

Enter 0= absent and 1= present. Exit chipping will occur at the end of the cutting stroke or on the side of the stroke emphasized by the individual sawing. As a rule, the largest chips of bone are removed on the cutting stroke as the blade exits the bone.

Harmonics: _____

Enter 0= absent and 1= present. Harmonic oscillations are found to exist in nearly all blades with alternating set teeth, and are the direct result of normal cutting action in hand and mechanically powered saws. Harmonics can provide information on characteristics of blade set and TPI.

Material Waste _____ Description: _____

Enter 0= absent and 1= present. The stout blade and ease of producing a cut with a power saw often creates a large amount of material waste. Because the cuts are produced with little energy expended, it is likely that more cuts are produced and more material is wasted.

Patterned Striae Shuffle: _____

Enter 0= absent and 1= present. This is typically seen in large-toothed saws where the teeth are raking material as they bounce over the pillars of bone. Accentuated raking at the level of the marrow cavity may also produce increased exit chipping as the saw seems to require more power to continue the progress through the bone.

Polish: _____

Enter 0= absent and 1= present. Polish is created by obliterating residual characteristics of the original cut through extended contact of the blade to the bone. This contact may be due to a lack of set, high-speed blade movement, blade bending in the kerf, blade binding, or any combination of these. Power saws, with increased speed and torque can polish bone if any of these factors occur for an extended time.

Pull out Striae/ Tooth Scratch: _____ # of striations: _____
Measurements: _____ Avg. Measurement: _____

Pull out striae are created when a saw is withdrawn from the kerf in mid-stroke. Enter 0= absent and 1= present. Record the number of consecutive striations in the cut surface. Measure the distance between each striation. The average distance between striations can provide

information regarding the number of teeth per inch in a normally set saw. For instance, in an alternate set saw the distance between striations is equal to the distance between two teeth (if the measurement is .2 inches, then the distance between teeth is .1 inch). Caution should be used with estimations of TPI from pull out striae because if the saw is a raker set the distance between two striations may represent the distance between 3 teeth instead of 2.

Tooth Hop: _____ # peaks/valleys: _____ Measurement: _____
(if present) (Specify peak to peak or valley to valley)

Enter 0= absent and 1= present. Record the number of peaks and valleys present in the tooth hop (i.e. 3 peaks and 2 valleys). Measuring the distance from peak to peak or valley to valley indicates the distance between teeth of the saw.

Overall Power Description: _____

Describe the overall power exhibited in the cut bone. Consider material waste, energy transfer, the number of false starts, kerf width, etc in the assessment of overall power.

NOTES:

Use this space to describe additional information regarding the cut bone specimen. Drawings of the cut bone should be included in this space depicting shape, saw progress, and any other important information.

REFERENCES

Alunni-Perret, V

2005 Scanning electron microscopy analysis of experimental bone hacking trauma. *Journal of Forensic Sciences* 50 (4): 796-801.

Andahl, RO

1978 The examination of saw marks. *Journal of the Forensic Science Society* 18: 31-36.

Blumenschine, Robert J, Curtis W. Marean, and Salvatore D Capaldo

1996 Blind Tests of Inter-analyst Correspondence and Accuracy in the Identification of Cut Marks, Percussion Marks, and Carnivore Tooth Marks on Bone Surfaces. *Journal of Archaeological Science* 23: 493–507.

Bonte, Wolfgang

1975 Tool marks in bones and cartilage. *Journal of Forensic Sciences* 20:315-325.

Burd, DQ and AE Gilmore

1968 Individual and Class Characteristics of Tools. *Journal of Forensic Sciences*, Vol 13, Pp. 390-396.

Burd, DQ and RS Greene

1957 Toolmark examination techniques. *Journal of Forensic Sciences* 2:297-310.

Burd, DQ and PL Kirk

1942 Tool marks: Factors involved in their comparison and use as evidence. *Journal of Criminal Law and Criminology*, Vol 32, pp 679-686.

Cunningham, Beryl M. and William F. Holtrop

1974 *Woodshop Tool Maintenance*. Peoria, Illinois: Chas. A. Bennett Co., Inc.

Bush, Peter, with J. Christi and N Rattle

2009 SEM Analysis of Saw Marks in Bone. Paper presented at the Annual Meeting of the American Academy of Forensic Sciences, Denver, February 19.

Di Maio, DJ and Di Maio, VM

1993 *Forensic Pathology*. New York: CRC Press.

Disston, Henry & Sons, Inc.

1922 *The Saw in History: A Comprehensive Description of the Development of This Most Useful of Tools From the Earliest Times to the Present Day*. Unknown author, Philadelphia: Keystone Saw, Tool, Steel and File Works. Sixth edition.

Dirkmaat, DC, LL Cabo, SD Ousley, and SA Symes

2008 New perspectives in forensic anthropology. *Yearbook Phys Anthropol* 51:33-52.

Freas, Laurel

2006 Scanning Electron Microscopy of Saw Marks in Bone. Paper presented at the Annual Meeting of the American Academy of Forensic Sciences, 12: 296.

Guilbeau, MG

1989 The Analysis of Saw Marks in Bone. M.A. Thesis, Department of Anthropology University of Tennessee, Knoxville, TN.

Guilbeau, MG

1991 The examination of bone saw dust. Paper presented at the 43rd Annual Meeting of the American Academy of Forensic Sciences, Anaheim, CA, February 18-23.

Jackson, A and D Day

1978 Tools and How to Use Them. Pp. 74-111. New York: Alfred A. Knopf.

Lanz, Henry

1985 Japanese Woodworking Tools. Sterling Publishing Co., Inc: New York, NY.

Nagyszalanczy, S.

2003 Tools That Saw. *In* The Homeowner's Ultimate Tool Guide: Choosing the Right Tool for Every Home Improvement Job. Pp. 78-107. Newtown, Connecticut: The Taunton Press, Inc.

Rae, A

2002 Hand Saws. Choosing & Using Hand Tools. New York: Lark Books. Pp. 188-201.

Salaman, R A

1975 Dictionary of Tools Used in the Woodworking and Allied Trades, c. 1700-1970. New York, NY: Charles Scribner and Sons.

Saville, PA, SV Hainsworth, and GN Ruddy

2006 Cutting crime: the analysis of the 'uniqueness' of saw marks on bone. *Int J Legal Med* 121:349-357

Self, C.

2005 Blade Runner: Knowing Your Saw Blades Will Improve Your Shop's Efficiency. *WoodShop News*, March 3: Pp. T29-T32.

Schwarz, C

2006 Handsaws: East vs. West. *Popular Woodworking*. January Pp. 56-61.

Shipman, Pat

1981 Applications of Scanning Electron Microscopy to Taphonomic Problems. *In The Research Potential of Anthropological Museum Collections*. A. M. Cantwell, J. B. Griffin and N. Rothschild, Eds., pp. 357-385. *Annals of the New York Academy of Sciences* 276.

Smith, OC

1996 Ballistic Bone Trauma. *In*, *Bones: Bullets, Burns, Bludgeons, Blunderers, And Why*. Eds, Symes, SA, OC Smith, HE Berryman, CE Peters, LA Rockhold, SJ Haun, JT Francisco, and TP Sutton. Workshop conducted for the American Academy of Forensic Sciences.

Spitz, Werner U., ed.

1993 Spitz and Fisher's *Medicolegal Investigation of Death*, 3rd Ed. Springfield, Illinois: Charles C. Thomas.

Symes, SA

1992 Morphology of Saw Marks in Human Bone: Identification of Class Characteristics. Ph.D. Dissertation, Department of Anthropology, University of Tennessee, Knoxville, TN.

Symes, S.A. and HE Berryman

1989a Dismemberment and mutilation: General saw type determination from cut surfaces of bone. Paper presented at the 41st Annual Meeting of the American Academy of Forensic Sciences, Las Vegas, NV, February 13-18.

1989b Examination of tool markings on bone from a White female from Hamilton County, TN, Case Number FA89-49. Unpublished manuscript on file at the Shelby County Medical Examiner's Office, Memphis, TN.

Symes, SA, HE Berryman, and OC Smith

1998 Saw Marks in Bone: Introduction and Examination of Residual Kerf Contour. *In: Forensic Osteology II, Advances in the Identification of Human Remains.* K.J. Reichs, Ed. Pages 333-352. Springfield, IL: Charles C. Thomas.

Symes, SA, MG Guilbeau, AB Falsetti, and CW Harlan

1988 Saw marks on bone: Any way you cut it. Paper presented at the 40th Annual Meeting of the American Academy of Forensic Sciences, San Diego, CA, February 15-20.

Symes, SA, AM Kroman, SMT Myster, C. W. Rainwater, and JJ Matia

2006 Anthropological Saw Mark Analysis on Bone: What is the Potential of Dismemberment Interpretation? Proceedings of the 59th Annual American Academy of Forensic Sciences, 12:301.

Symes, SA, CH Lahren, and FK King, Jr.

1990 Saw Dismemberment: A Slice of Life. Paper presented at the 42nd Annual Meeting of the American Academy of Forensic Sciences, Cincinnati, OH, February 19-24.

Symes, SA, OC Smith, HE Berryman, CE Peters, LA Rockhold, SJ Haun, JT Francisco, and TP Sutton

1996 Bones: Bullets, Burns, Bludgeons, Blunderers, And Why. Proceedings of the American Academy of Forensic Sciences 2: 10-11.

Symes, SA, OC Smith, CD Gardner, JT Francisco, and GA Horton.

1999 Anthropological and Pathological Analysis of Sharp Trauma in Autopsy. Proceedings of the American Academy of Forensic Sciences, 5: 177-178.

Symes, SA, J Williams, E Murray, J Hoffman, T Holland, J Saul, F Saul and E Pope
2002 Taphonomic context of sharp-force trauma in suspected cases of human mutilation and dismemberment. *In: Advances in Forensic Taphonomy: Method, Theory, and Archaeological Perspectives*. W. Haglund and M. Sorg, eds. Boca Raton, FL: CRC Press, Pp. 403-434.

Wilson, S, ed.
1994 Popular Mechanics Encyclopedia of Tools & Techniques. New York: Hearst Books.

PART II: APPENDICES

Appendix II-A: Bone Sample Measurements

<i>Sample #</i>	<i>Contents</i>	<i>Def. - Measurement</i>	<i>(mm)</i>
1	Fem - R	Max. Length	499.5
		Bicondylar Length	496
		Epicondylar Breadth	90
		Max. Head Diameter	50
		A-P Subtrochanteric Diameter	34
		M-L Subtrochanteric Diameter	36.5
		A-P Midshaft Diameter	35
		M-L Midshaft Diameter	36
		Midshaft Circumference	109
2	Hum - R	Max. Length	366
		Epicondylar Breadth	69
		Vertical Diameter of Head	51
		Max. Diameter at Midshaft	26
		Min. Diameter at Midshaft	21.5
3	Hum - L	Max. Length	371
		Epicondylar Breadth	69.5
		Vertical Diameter of Head	50.5
		Max. Diameter at Midshaft	25
		Min. Diameter at Midshaft	20.5
4	Fem - R	Max. Length	476
		Bicondylar Length	474
		Epicondylar Breadth	86
		Max. Head Diameter	46.5
		A-P Subtrochanteric Diameter	33.5
		M-L Subtrochanteric Diameter	34.5
		A-P Midshaft Diameter	35.5
		M-L Midshaft Diameter	32.5
		Midshaft Circumference	109
5	Fem - L	Max. Length	478
		Bicondylar Length	476
		Epicondylar Breadth	84
		Max. Head Diameter	47.5
		A-P Subtrochanteric Diameter	33.5
		M-L Subtrochanteric Diameter	32.5
		A-P Midshaft Diameter	33.5
		M-L Midshaft Diameter	30
		Midshaft Circumference	109.5
6	Hum - L	Max. Length	35.6
		Epicondylar Breadth	62
		Vertical Diameter of Head	50.5
		Max. Diameter at Midshaft	26
		Min. Diameter at Midshaft	21

<i>Sample #</i>	<i>Contents</i>	<i>Def. - Measurement</i>	<i>(mm)</i>
7	Fem - L	Max. Length	505
		Bicondylar Length	502
		Epicondylar Breadth	96
		Max. Head Diameter	56
		A-P Subtrochanteric Diameter	31.5
		M-L Subtrochanteric Diameter	38
		A-P Midshaft Diameter	30.5
		M-L Midshaft Diameter	34.5
		Midshaft Circumference	102
8	Hum - L	Max. Length	380
		Epicondylar Breadth	73
		Vertical Diameter of Head	57.5
		Max. Diameter at Midshaft	25
		Min. Diameter at Midshaft	20.5
9	Fem - L	Max. Length	421
		Bicondylar Length	419
		Epicondylar Breadth	81
		Max. Head Diameter	46
		A-P Subtrochanteric Diameter	30.5
		M-L Subtrochanteric Diameter	31
		A-P Midshaft Diameter	30
		M-L Midshaft Diameter	30
		Midshaft Circumference	95
10	Hum - R	Max. Length	302.5
		Epicondylar Breadth	65
		Vertical Diameter of Head	48
		Max. Diameter at Midshaft	24.5
		Min. Diameter at Midshaft	19.5
11	Hum - L	Max. Length	301
		Epicondylar Breadth	64.5
		Vertical Diameter of Head	44.5
		Max. Diameter at Midshaft	23
12	Fem - R	Max. Length	440
		Bicondylar Length	437
		Epicondylar Breadth	79.5
		Max. Head Diameter	42
		A-P Subtrochanteric Diameter	25
		M-L Subtrochanteric Diameter	30.5
		A-P Midshaft Diameter	27.5
		M-L Midshaft Diameter	26.5
		Midshaft Circumference	86

Sample #	Contents	Def. - Measurement	(mm)
13	Fem - L	Max. Length	439
		Bicondylar Length	435
		Epicondylar Breadth	79.5
		Max. Head Diameter	43.5
		A-P Subtrochanteric Diameter	24.5
		M-L Subtrochanteric Diameter	32.5
		A-P Midshaft Diameter	27.5
		M-L Midshaft Diameter	28
		Midshaft Circumference	94.5
		14	Hum - R
Epicondylar Breadth	60		
Vertical Diameter of Head	44		
Max. Diameter at Midshaft	19.5		
Min. Diameter at Midshaft	15.5		
15	Hum - L	Max. Length	303
		Epicondylar Breadth	58.5
		Vertical Diameter of Head	42.5
15		Max. Diameter at Midshaft	12.5
		Min. Diameter at Midshaft	14.5
16	Fem - R (partial prox)	Max. Length	(N/A)
		Bicondylar Length	(N/A)
		Epicondylar Breadth	75
		Max. Head Diameter	(N/A)
		A-P Subtrochanteric Diameter	28
		M-L Subtrochanteric Diameter	32.6
		A-P Midshaft Diameter	25.6
		M-L Midshaft Diameter	27.7
		Midshaft Circumference	87

Sample #	Contents	Def. - Measurement	(mm)
17	Fem - R (S&D only)	Max. Length	(N/A)
		Bicondylar Length	(N/A)
		Epicondylar Breadth	79.5
		Max. Head Diameter	(N/A)
		A-P Subtrochanteric Diameter	(N/A)
		M-L Subtrochanteric Diameter	(N/A)
		A-P Midshaft Diameter	26
		M-L Midshaft Diameter	27
		Midshaft Circumference	84
18	Fem - L	Max. Length	429
		Bicondylar Length	431
		Epicondylar Breadth	79.2
		Max. Head Diameter	39.7
		A-P Subtrochanteric Diameter	25.9
		M-L Subtrochanteric Diameter	32.1
		A-P Midshaft Diameter	27
		M-L Midshaft Diameter	26.3
		Midshaft Circumference	91
19	Hum - L	Max. Length	309
		Epicondylar Breadth	57.1
		Vertical Diameter of Head	45.9
		Max. Diameter at Midshaft	17.1
		Min. Diameter at Midshaft	20.4

Appendix II-B: Saw Sample Information

Code	Hand or Power	Blade (Saw) Name	Tooth Height	Tooth Width	Distance B/W Teeth	TPI
100	HAND	Dove tail (extra fine)		0.020	0.13	8
100*	HAND	Fine Finish Work Pull Saw (extra fine tooth)	0.099			18
101	HAND	Utility saw	0.150	0.066	0.03	18
102	HAND	X-tra Fine Cut Veneer & Laminate Fine Tooth Saw	0.070	0.103	0.09	11
103	HAND	Jab Saw	0.185	0.100	0.09	11
104	HAND	Finish Blade	0.016	0.150	0.11	8
105	HAND	Compass Saw	0.109	0.110	0.08	11
106	HAND	Metal Cutting Saw	0.036	0.135	0.12	9
107	HAND	Rip Saw	0.012	0.046	0.05	23
108	HAND	Rip Saw	0.155	0.144	0.15	7
109	HAND	General Carpentry	0.151	0.145	0.09	8
110	HAND	Back Saw (crosscut???)	0.053	0.100	0.07	13
111	HAND	Junior Hacksaw		0.058	0.07	15
112	HAND	Coping Saw (Fine)				24
113	HAND	Coping Saw (Medium)				
114	HAND	Coping Saw (Coarse)				15
115	HAND	Fine Jeweler's Blade				
116	POWER	Circular (Plywood, Plastic, Laminates)		0.010		52
117	POWER	Circular (Plywood, Plastic, Laminates)				
118	POWER	Circular (Plywood)				
119	POWER	Reciprocating (Wood/Demolition)				
120	POWER	Reciprocating (Wood/Demolition)				5-8
121	POWER	Reciprocating (Demolition)				6
122	POWER	Reciprocating (Metal)				8
123	POWER	Reciprocating (Metal)				14
124	POWER	Reciprocating (Fine) w/ Ryobi				14
125	POWER	Reciprocating (Medium) w/ Ryobi				24
126	POWER	Circular (Fine Cutting) w/ Skilsaw				10

Code	PPI	Set Type	Tooth Type	Direction of Cut	Blade Length	Suggested Use	Purpose
100	19	ALT		PULL	10.625	WOOD	
100*	19	ALT	CUT	PULL	10.63	WOOD	Fine Finish Work
101	12	ALT	CUT	P/P	10	WOOD	
102	12	ALT	CHISEL	PUSH	12	VENEER AND LAMINATE	
103	9	ALT	CUT	P/P	6.34	CEMENT BOARD	
104	12	ALT	CUT	P/P	10	WOOD	
105	10	ALT	CHISEL	PUSH	10	???	
106	24	WAVE	CHISEL	PUSH	10	METAL	
107	8	ALT	CHISEL	PUSH	20	WOOD	
108	9	ALT	CUT	PUSH (tri-bevel design)	20	WOOD	
109	14	ALT	CUT	PULL	12	WOOD	
110	16	ALT	CHISEL	PUSH	14	WOOD	
111	25	WAVE	CHISEL	PUSH			
112							
113	16	ALT	CHISEL	PUSH			
114							
115	53						
116						Plywood; Plastic; Laminates	
117						Plywood; Plastic; Laminates	Framing
118							
119					9	Wood/Demolition	
120	7	RAKER (7th)	CHISEL	PULL	6	Wood/Demolition	
121	9	WAVE	CHISEL	PULL	6	Demolition	
122	15	RAKER (6th)	CHISEL	PULL	6	Metal	
123	15	RAKER (3rd)	CHISEL	PULL	9	Metal	
124	25	WAVE	CHISEL	PULL			
125	11	RAKER (3rd)	CHISEL	PULL			
126							

Code	Painted	Label Paint	Brand Name	Description	Attaches to
100	NO	BLUE	MARPLES MPS1619		
100*	NO	BLUE	IRWIN	Fine Finish Work Pull Saw	
101	NO	BLACK	STANLEY 20-221	SharpTooth	
102	NO	BLACK	Buck Bros. 41021	heat treated teeth	
103	NO	BLACK with RED	STANLEY 20-556A	FatMax with SharpTooth	
104	NO	NO	STANLEY - 15-090 Nest of Saws		black plastic handle
105	NO	NO	STANLEY - 15-090 Nest of Saws		black plastic handle
106	NO	NO	STANLEY - 15-090 Nest of Saws		black plastic handle
107	NO	NO	STANLEY - 20-029		
108	NO	RED	HUSKY - 538339		
109	NO	BLUE	MARPLES - MPS1714		
110	NO	BLACK	Buck Bros. 41020		
111	NO	NO	Buck Bros. 40124		
112	NO	NO	Buck Bros. 40336		
113	NO	NO	Buck Bros. 40337		
114	NO	NO	Buck Bros. 40338		
115	NO	NO	X-ACTO - X752		
116	NO	BLACK	DeWALT - DW3326		
117	NO	BLACK	RIDGID - R0724B	Titanium Coating	
118	NO	BLACK	BLACK & DECKER - 73-367		
119	WHITE	BLACK with RED	MILWAUKEE - 5026		
120	WHITE	BLACK with RED	MILWAUKEE - 5021		
121	WHITE	BLACK with RED	MILWAUKEE - 5701		
122	WHITE	BLACK with RED	MILWAUKEE - 5782		
123	WHITE	BLACK with RED	MILWAUKEE - 5787		
124	NO		Ryobi - RJ162VK		
125	NO		Ryobi - RJ162VK		
126	NO	BLACK	SKILSAW - 13247		

**Appendix II-C:
Randomized Cutting Sequence**

Cut #	Bone	Saw
1	1	123
2	1	122
3	1	111
4	1	116
5	1	104
6	1	115
7	1	116
8	1	103
9	1	124
10	1	119
11	1	112
12	1	104
13	1	108
14	1	111
15	1	121
1	2	107
2	2	103
3	2	119
4	2	112
5	2	111
6	2	107
7	2	113
8	2	114
9	2	109
10	2	116
11	2	122
12	2	115
13	2	118
14	2	114
15	2	104
1	3	124
2	3	120
3	3	103
4	3	121
5	3	102
6	3	118
7	3	122
8	3	125
9	3	116
10	3	104
11	3	105
12	3	123
13	3	103
14	3	108
15	3	106
1	4	100
2	4	118
3	4	110
4	4	101

5	4	120
6	4	108
7	4	101
8	4	106
9	4	122
10	4	103
11	4	114
12	4	113
13	4	118
14	4	122
15	4	104
1	5	105
2	5	115
3	5	125
4	5	102
5	5	124
6	5	126
7	5	121
8	5	120
9	5	126
10	5	116
11	5	101
12	5	114
13	5	112
14	5	100
15	5	109
1	6	113
2	6	124
3	6	115
4	6	111
5	6	106
6	6	114
7	6	123
8	6	106
9	6	107
10	6	102
11	6	103
12	6	113
13	6	100
14	6	112
15	6	126
1	7	110
2	7	107
3	7	126
4	7	108
5	7	102
6	7	103
7	7	110
8	7	126
9	7	124
10	7	119
11	7	109
12	7	125

13	7	106
14	7	115
15	7	108
1	8	126
2	8	114
3	8	116
4	8	121
5	8	109
6	8	105
7	8	122
8	8	105
9	8	108
10	8	114
11	8	120
12	8	116
13	8	125
14	8	105
15	8	126
1	9	118
2	9	121
3	9	112
4	9	112
5	9	117
6	9	103
7	9	124
8	9	110
9	9	124
10	9	100
11	9	113
12	9	125
13	9	112
14	9	107
15	9	121
1	10	106
2	10	105
3	10	110
4	10	125
5	10	105
6	10	118
7	10	123
8	10	107
9	10	123
10	10	100
11	10	124
12	10	125
13	10	102
14	10	106
15	10	107
1	11	117
2	11	107
3	11	115
4	11	117
5	11	117

6	11	120
7	11	118
8	11	100
9	11	109
10	11	123
11	11	101
12	11	120
13	11	112
14	11	117
15	11	103
1	12	101
2	12	109
3	12	105
4	12	125
5	12	109
6	12	119
7	12	104
8	12	116
9	12	107
10	12	106
11	12	118
12	12	101
13	12	107
14	12	102
15	12	126
1	13	108
2	13	124
3	13	113
4	13	110
5	13	115
6	13	105
7	13	121
8	13	112
9	13	114
10	13	119
11	13	120
12	13	104
13	13	121
14	13	118
15	13	110
1	14	125
2	14	121
3	14	106
4	14	106
5	14	117
6	14	114
7	14	123
8	14	109
9	14	124
10	14	100
11	14	109
12	14	119
13	14	116

14	14	117
15	14	111
1	15	119
2	15	101
3	15	104
4	15	117
5	15	109
6	15	123
7	15	115
8	15	105
9	15	107
10	15	103
11	15	102
12	15	125
13	15	123
14	15	121
15	15	113
1	16	126
2	16	123
3	16	100
4	16	108
5	16	122
6	16	113
7	16	114
8	16	100
9	16	108
10	16	122
11	16	112
12	16	110
13	16	110
14	16	111
15	16	115
1	17	103
2	17	101
3	17	121
4	17	104
5	17	111
6	17	113
7	17	120
8	17	102
9	17	114
10	17	122
11	17	113
12	17	104
13	17	119
14	17	104
15	17	118
1	18	120
2	18	122
3	18	111
4	18	101
5	18	118
6	18	108

7	18	101
8	18	109
9	18	101
10	18	122
11	18	100
12	18	117
13	18	124
14	18	117
15	18	126
1	19	115
2	19	105
3	19	120
4	19	116
5	19	102
6	19	
7	19	
8	19	
9	19	
10	19	
11	19	
12	19	
13	19	
14	19	
15	19	

Appendix II-D: Traits and Coding

Trait	Code	What trait tells us or contributes to
Kerf Flare	Absent 0 / Present 1	Indicates handle end of the kerf
Exit Chipping	Absent 0 / Present 1	Direction of blade progress; occur at the end of the cutting stroke; large chips as a rule indicate the side where the blade exits the bone
Bone Islands	Absent 0 / Present 1	Bone islands are a characteristic associated with alternating set blades and blade drift. A wider set increases blade drift and leaves material in the midline of the kerf.
Tooth Hop	Absent 0 / Present 1	Measuring from peak to peak or dip to dip of each wave indicates the distance between teeth of the saw; Can occur with a variety of saws; accurately indicates spacing of saw teeth
Break-away Spur	Absent 0 / Present 1	Size of the spur often depends on the amount force applied across the bone; for example weight of a handheld circular power saw or chain saw often produces a large break-away spur
Pull Out Striae (Tooth Scratch)	Absent 0 / Present 1	estimations of tooth distance (every other tooth in alternate set); with raker set may represent the distance of three teeth
Tooth Imprint & Floor Dip	Absent 0 / Present 1	Consecutive tooth imprint features can be measured in false starts and break-away spurs to represent the distance between teeth, indicate the set (shape) of the blade and indicate the shape of the individual tooth.
W-shaped Kerf Floor	Absent 0 / Present 1	Indicates a crosscut saw
Flat Bottom Kerf Floor	Absent 0 / Present 1	Indicates a rip saw
Blade Drift	Absent 0 / Present 1	There are certain drift actions that all blades with alternating set teeth follow since saw teeth are set to produce a cut wider than the saw blade.
Flat Kerf Floor Contour	Absent 0 / Present 1	Typical straight blades, inclusive of both hand- and mechanically-powered saws produce a flat-bottomed kerf.
Curved Kerf Floor Contour	Absent 0 / Present 1	Curved blades (such as circular saws) and flexible blades (such as gigli saws) will leave a curved kerf floor.
Entrance Shaving	Absent 0 / Present 1	Indicates the side of the bone that the saw enters
Harmonics	Absent 0 / Present 1	Found to exist in nearly all blades with alternating set teeth; simply the expression of blade drift progress and are good indicative characteristics of blade set and TPI.
AREAS WE WANT TO LOOK AT		
<i>Kerf Wall</i>		Can also offer information about teeth per inch, saw power, and direction of cut.
<i>Kerf Floor</i>		Offer the most information about the points of each tooth and the relationship of the points to each other or the set (lateral bending) and number of teeth per inch (TPI).
<i>False Start</i>		May indicate blade width; may give clues to TPI
INFORMATION WE WANT TO GAIN		
<i>Minimum kerf width</i>		Directly related to the width of the set of the blade
<i>Teeth Per Inch</i>		It is a measure of the number of completely occurring (not just points) teeth per inch
<i>Tooth Width</i>		Can be calculated in two ways - measurement of floor patterns and measurement of residual tooth trough; Floor patterns give an average estimation of saw tooth width while the residual tooth image produces an accurate image of an actual tooth
<i>Tooth Orientation</i>		Diagnosed in concert with direction of sawing motion; features visible in analyzing saw direction will allow for a determination of whether or not a blade's power stroke is occurring on the push or the pull

AFTE Handout

KNIFE AND SAW MARK ANALYSIS ON BONE

STEVEN A. SYMES
CHRISTOPHER W. RAINWATER
SUSAN M. T. MYSTER
ERIN N. CHAPMAN



DEPARTMENT OF APPLIED FORENSIC SCIENCES
MERCYHURST COLLEGE
ERIE, PENNSYLVANIA

CONTACT: [SSYMES@MERCYHURST.EDU](mailto:ssymes@mercyhurst.edu)

RESEARCH FUNDED BY THE NATIONAL INSTITUTE OF JUSTICE AND THE NATIONAL FORENSIC ACADEMY

OUTLINE OF PRESENTATION - ASSOCIATION OF FIREARMS AND TOOLMARK EXAMINERS 29 MAY 2007

Presenters: Steven A. Symes PhD, DABFA
Susan M. T. Myster PhD, DABFA
Christopher W. Rainwater, MS
Erin N. Chapman, BA

I Introduction to Trauma

- 1 Sources of trauma → Blunt; Ballistic; Sharp; Burn; Healing
 - Description of each type
- 2 Toolmarks overlooked
 - Discussion of the potential of dismemberment interpretation
 - Current Status in Toolmark Analysis in Bone
- 3 Objectives of Talk

II Introduction to Knives

- 1 Description of knife cut mark characteristics and terminology
- 2 Anatomy of a cut
 - Serrated
 - Striae
 - Patterned

III Demonstration of Knife Stab Wound (KSW) vs Knife Cut Wounds (KCW) vs. Knife Chopping

- 1 Knife stab wounds description and case study exemplars
- 2 KSW in cartilage
- 3 KSW in bone

IV Introduction to Saws

- 1 General description of saws
- 2 Anatomy of a cut
 - Kerf
 - Size → tooth width, kerf width, distance between teeth (if serrated)
 - Set
 - Shape → kerf floor: edge; trough
 - Power

- Direction → kerf flare
 - * Direction of progress
 - * Direction of stroke (power)

- 3 Class (not type) characteristics help narrow field of potential saws/tools
- 4 Saw Terminology and Characteristics
- 5 Information contained in handout
- 6 Brief description and example of each

V Description of Saw Trauma Analysis using Case Studies

- 1 Minnesota Dismemberment (Hand Saw)
- 2 New York serial killer
- 3 San Jose (Power Saw)
- 4 Tennessee (Pull Saw)
- 4 Tennessee (Chain Saw)

VI Misconceptions Common amongst Anthropologists – Analysis of Bone Trauma

- 1 Use of microscopes and scanning electron microscopes
- 2 Analysis of cut surfaces without a microscope
- 3 Straight cut surface indicates a power saw
- 4 Cut surfaces do not reveal diagnostic characteristics
- 5 Hesitation marks?
- 6 Anthropologists need to measure and quantify everything

VII Practical Demonstration

- 1 Using the ELMO and Saw Mark Data Collection Sheet Dr. Symes will go through the analysis of an exemplar case
- 2 The class will split into groups
 - A cut deer metapodial will be analyzed and, using the Saw Mark Data Collection Sheet, results will be compared to a short list of potential saws in the back of manual

VIII Final discussion of relevance of analysis

- 1 Comparison of anthropological vs. toolmark analyst approach
- 2 Class vs. individual characteristics
- 3 Comparison of equipment—is it possible to do toolmark analysis for class comparisons on a comparison microscope?

INTRODUCTION TO SAW MARK ANALYSIS ON BONE

It is important to understand a few basic concepts about saws and saw blade action before attempting to interpret saw marks in bone. All saws have teeth. As saw teeth cut into bone a groove, or kerf, is formed. Saw mark analysis essentially examines saw cut kerfs. A kerf can be defined as the walls and floor of a cut. Floors are expressed in false-starts and occasionally in break-away spurs. Kerf floors, when present, offer the most information about the points of each tooth and the relationship of the points to each other or the set (lateral bending) and number of teeth per inch. Kerf walls offer information about the sides of the teeth. Wall striae commonly represent only those teeth set to that particular side; while shape, depth, and frequency of these striae may represent the shape of the blade, the amount of energy transferred to the material, and the motion in which the blade travels to cut bone (Symes 1992). The object of saw mark analysis is to recognize characteristics on kerf walls and floors that may accurately reveal:

1. The dimensions and shape of the blade and teeth of a saw
2. How the tool was powered, mechanically or manually
3. How a tool was used to accomplish the dismemberment or mutilation.

Individual characteristics are subject to interpretations of positive identification, consistency, elimination, insufficient results, and unsuitable comparisons (AFTE Criteria for Identification Committee Report 1990:276-277). However, the narrowing of potential saws is facilitated by class (not individualizing) characteristics. This narrowed field of tools can aid in the search for an appropriate tool utilized in a crime and the documentation of criminal behavior. With a standardized analysis of saw marks, the following class characteristics can be identified:

1. Saw Size
2. Saw Set
3. Saw Shape
4. Saw Power
5. Direction of Saw Motion

This manual is organized using these five class characteristics. Each characteristic is followed by definitions of the features used in determining that characteristic. Each definition is marked with the most appropriate location of the saw cut by which to observe that feature, whether it be kerf floor (KF), kerf wall (KW), break-away spur (BA), or false start (FS)

INTRODUCTORY TERMINOLOGY

Kerf

The walls and floor of a cut. Floors are expressed in false-starts and occasionally in break-away spurs. Kerf floors, when present, offer the most information about the points of each tooth and the relationship of the points to each other or the set (lateral bending) and number of teeth per inch (TPI). Kerf walls can also offer information about teeth per inch, saw power, and direction of cut.

Break-Away Spur

The break-away spur is a projection of uncut bone at the terminal end of the cut after the force breaks the remaining tissue which commonly occurs on the stable end of the bone. The break-away spur is often as diagnostic as the kerf floor. The size of the spur often depends on the amount force applied across the bone resulting in a fracture of the bone. For instance, the weight of a handheld circular power saw or chain saw often produces a large break-away spur.

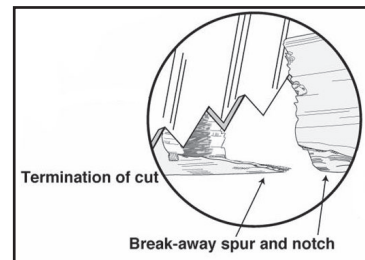

False Starts

False start kerfs are cuts that do not completely section bone and are composed of two initial corners, two walls, two floor corners, and a floor. These are not considered 'hesitation' marks.

SAW SIZE

Blade Width

Minimum Kerf Width. This is simply a measurement of the width of a kerf. The minimum kerf width is directly related to the width of the set of the blade.

Teeth Per Inch (TPI)

This is literally the number of teeth per inch. It is a measure of the number of completely occurring (not just points) teeth per inch. There is one more point per inch (ppi) than there are teeth per inch.

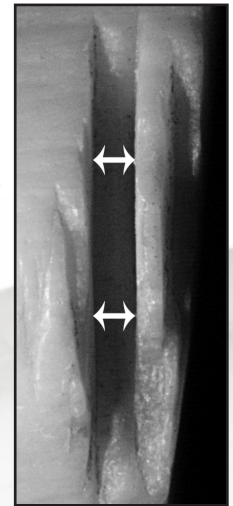
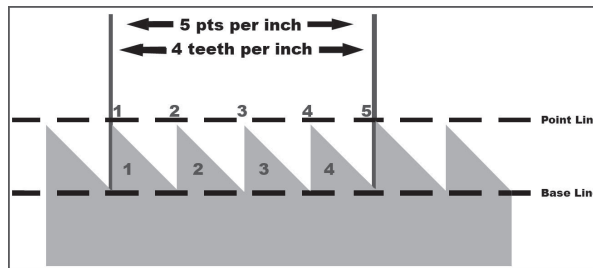

Tooth Hop. Striae across the face of the bone generally progress in a straight pattern. With close observation, the residual kerfs (striations) occasionally show patterned hopping or predictable waves. Blade hopping is created as teeth begin to enter the kerf and each successive tooth strikes bone, which produces movement of the whole blade. Measuring from peak to peak or dip to dip of each wave indicates the distance between teeth of the saw. It has been demonstrated that tooth hop can occur with a variety of saws and accurately indicates spacing of saw teeth. (KW)

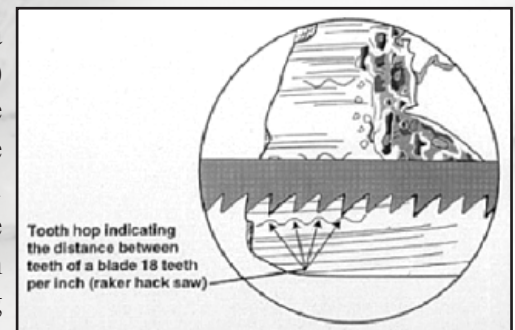

Pull Out Striae (Tooth Scratch). Pull out striae are simply the presence of perpendicular striae on the cut surface of the bone. These are created when the saw is withdrawn from the kerf in mid-stroke. This has been recognized by Bonte (1975:319) as appearing “vertical to the sawing level which extend[s] over several saw marks . . . [and] corresponds, with normally set saws, to twice the distance between the teeth.” Pull out striae are characteristics that do not easily stand alone and are most useful when used to corroborate other more reliable estimations of tooth distance. Unfortunately the phrase “normally set saws” is a misleading one. Alternating set saws can leave this type of pattern but a saw with a raker set may leave striae that represent the distance of three rather than two teeth. (KW)

Harmonics. Saw mark harmonics are described as peaks and valleys exhibited three-dimensionally in bone cross sections. Harmonic oscillations are found to exist in nearly all blades with alternating set teeth, and are the direct result of normal cutting action in hand and mechanically powered saws. Harmonics are simply the expression of blade drift progress and are good indicative characteristics of blade set and TPI. (KW)

Tooth Imprint and Floor Dip. These are resultant of saw teeth combining actions to cut a kerf floor in bone. When the floor of the kerf is examined on end, the seemingly flat-bottomed kerf may actually be notched or wavy. Tooth imprints and floor dip are residual imprints from tooth points in the kerf floor created after a saw is interrupted in the cutting stroke. Consecutive tooth imprint features can be measured in false starts and break-away spurs to represent the distance between teeth, indicate the set (shape) of the blade and indicate the shape of the individual tooth. (Andahl 1978:36-37; Symes 1992). (KF)

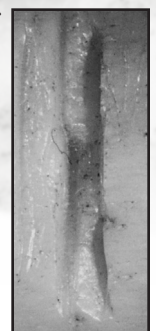

Tooth Width

Saw tooth width can be calculated in two ways, measurement of floor patterns and measurement of residual tooth trough. Floor patterns give an average estimation of saw tooth width while the residual tooth image, if properly interpreted, produces an accurate image of an actual tooth. (KF)

SAW SET

There are three major types of saw tooth set describing the lateral bend of teeth; alternating, raker, and wavy. A cheaper blade may exhibit no set if there is no lateral bend to the teeth.

Alternating Set

Each subsequent tooth is laterally bent to the opposite side in an alternating pattern.

Blade Drift. There are certain drift actions that all blades with alternating set teeth follow since saw teeth are set to produce a cut wider than the saw blade. This pattern of teeth drifting across the kerf floor is defined here as saw blade drift, where every tooth entering the material creates a direction change in the tooth carving the bone. (KF)

Bone Islands. Bone islands are a characteristic associated with alternating set blades and blade drift. A wider set increases blade drift and leaves material in the midline of the kerf. (KF)

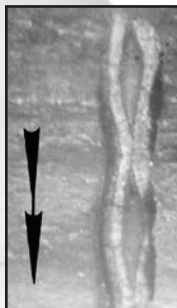

Raker Set

Teeth are laterally set to opposites similar to the pattern in alternating set saws. The raker set, however, introduces a tooth with no lateral bend subsequent to the two teeth set to either side.

Wavy Set

In wavy set blades, teeth are laterally bent in groups. The number of teeth in a group varies and this is most typically seen in fine-toothed hacksaw blades.

SAW SHAPE

Shape applies to the contour of the blade, the tooth as it is cut out of the saw blade, and if the teeth are filed at an angle. The most common classifications are rip and crosscut saws. These styles are important in that each function in a different manner to effectively cut different types of material.

Contour

Flat. Typical straight blades, inclusive of both hand- and mechanically-powered saws produce a flat-bottomed kerf. (KF)

Curved. Curved blades (such as circular saws) and flexible blades (such as gli saws) will leave a curved kerf floor. (KF)

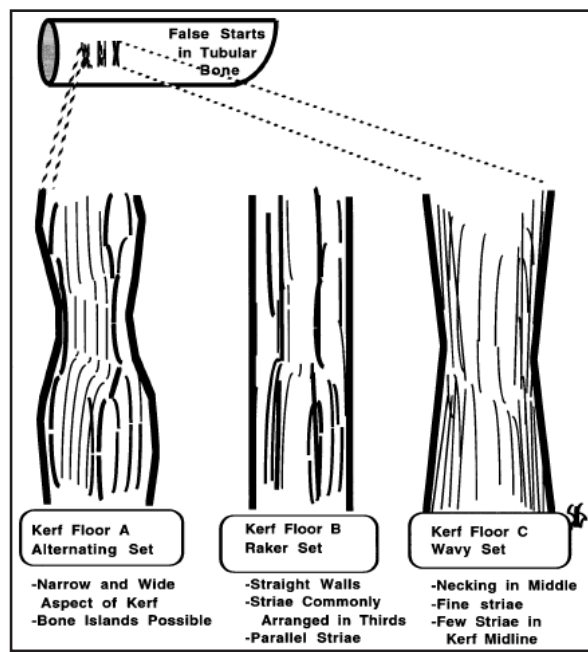
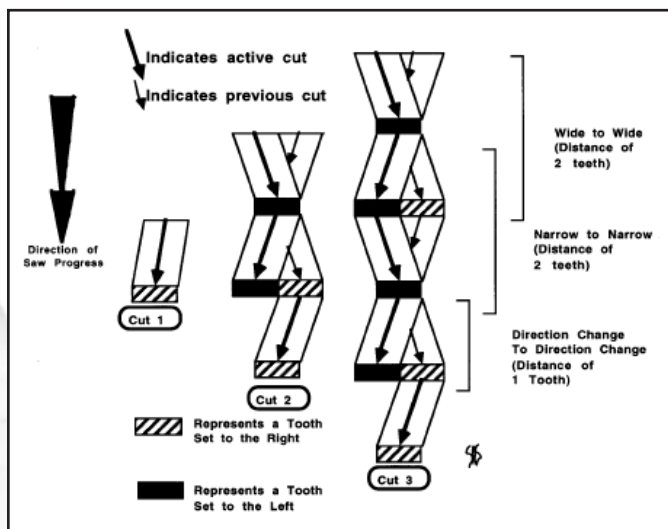
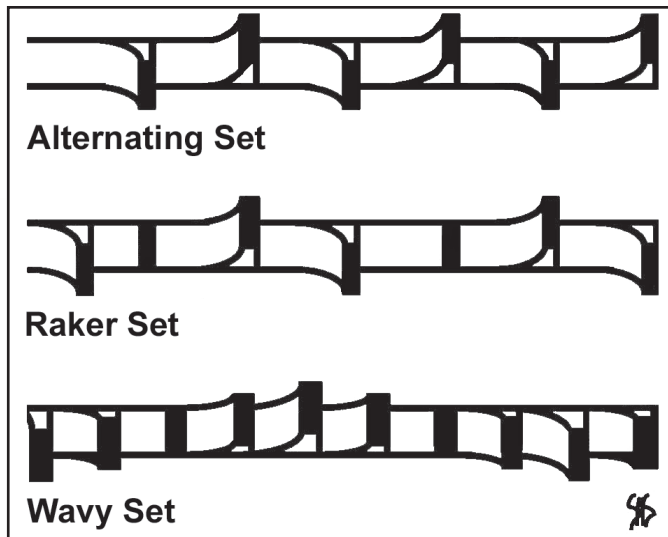

Tooth Orientation

Tooth orientation is diagnosed in concert with the direction of sawing motion. The confluence of features visible in analyzing saw direction will allow for a determination of whether or not a blade's power stroke is occurring on the push or the pull.

Pull Saw. A typical "Japanese" saw cuts on the pull stroke. It has a thinner blade and produces less material waste which, in turn, creates a narrower kerf. In general, pull saws have smaller teeth and more teeth per inch producing a cleaner cut but at a slower rate than a push saw.

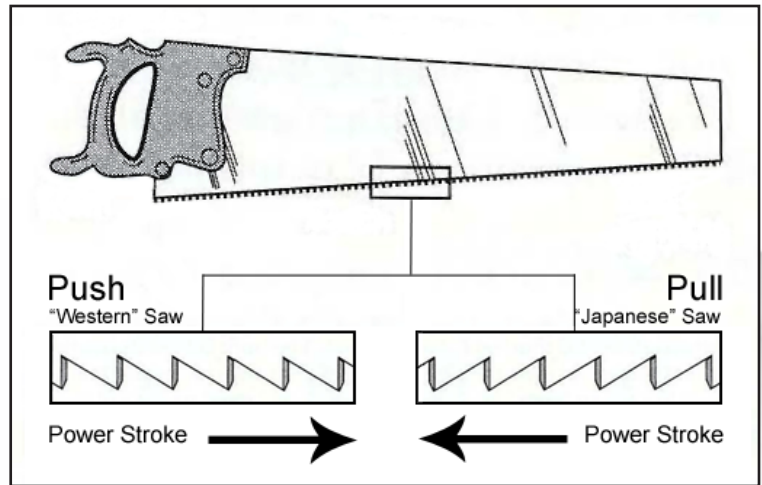

Push Saw. A typical "Western" saw cuts on the push stroke. It has a wider blade and produces more material waste which, in turn, creates a wider kerf. In general, push saws have larger teeth and the push stroke is more powerful giving the cuts a more accurate and efficient action than a pull saw.

Tooth Angle

Rip. The teeth of a rip saw are not angled or filed. The teeth are simply notched out of the blade. As such, these saws essentially chisel out material rather than cut it. Rip saws are designed to cut with the grain of wood.

Crosscut. A crosscut saw has teeth that have been filed to an angle. The filing allows each tooth to act as a tiny blade which will cut through material. Crosscut saws are designed to cut across the grain of wood.

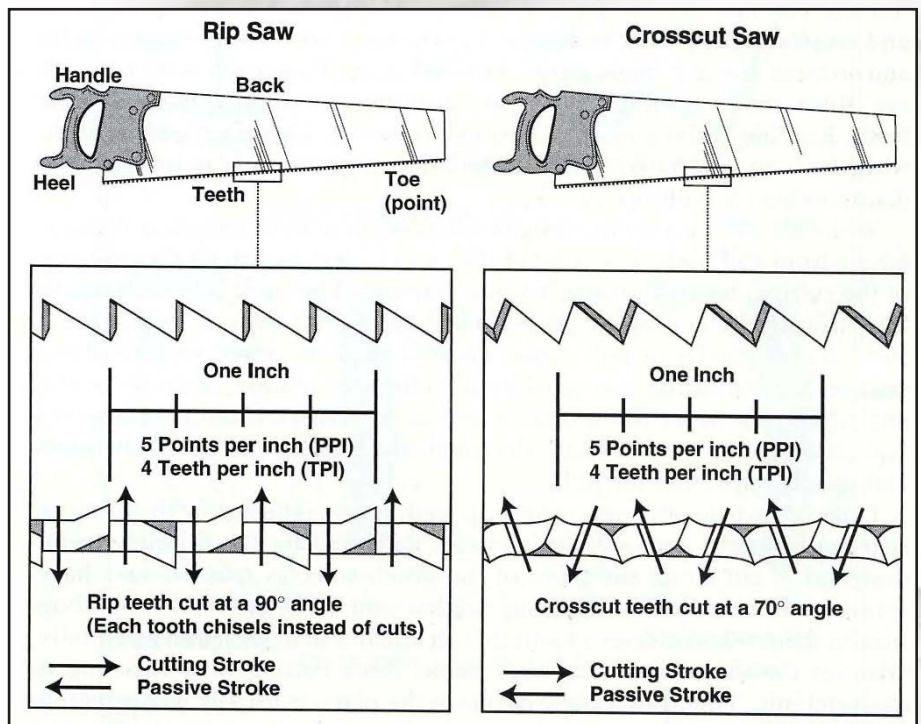

SAW POWER, HAND VS. MECHANICAL

Separating hand powered from mechanically powered saws is approached in by the examination of three characteristics; consistency of cut, energy transfer, and material waste. All characteristics increase with mechanically powered saws.

Consistency of Cut

Consistency of cut is anticipated in continuous cut power saws, where the blade continuously cuts material at high speeds. However, this consistency is evident in all power saws, even those with reciprocating actions. Hand powered saws typically exhibit an inconsistency in cut evident on the kerf wall. (KW)

Energy Transfer

Mechanically powered saws increase energy transfer to cut bone. Increased tooth speed, saw weight, and torque lead to a tendency to inadvertently discontinue a cut. Because of the ease of the cut, it is not important to reinsert

the blade in the kerf that was initially started. The opposite tendency is true in hand powered saws as it is more efficient to reinsert the blade in the false start. (FS)

Material Waste

Power saws are generally characterized as wasteful of material. This may be accredited to the stout blade design or the “ease” of producing a cut. If power saw cuts are produced with little energy expended, it is likely that more cuts are produced and more material is wasted. (FS)

DIRECTION OF SAW MOTION

Cutting Stroke

Cutting stroke is defined as a continuous action or a single direction of a reciprocating action that produces a majority of the cut. If an equal force is applied to a reciprocating blade, the direction of stroke cutting or chiseling the most bone is the direction of the cutting stroke.

Blade Progress

Indicators of direction of saw progress center on the false start and break away spur. Initial cuts are commonly accompanied by false starts, where individual teeth strike and incise material or where actual kerfs are abandoned for another cut. The plane formed between the false start and the break-away spur or notch gives the precise direction of saw progress. Direction of blade progress is perpendicular to stroke and tooth striae.

Entrance Shaving. As the saw enters the side of the bone, the blade can shave the bone entrance giving it a polished and scalloped appearance. This shaving can be due to twisting of the saw such that the blade is not allowed a direct path into the kerf, but more often it is simply due to the tooth set being wider than the blade, forcing each tooth to cut a kerf. Seldom is there chipping as the tooth enters the bone, and if present, it is difficult to observe. (KW)

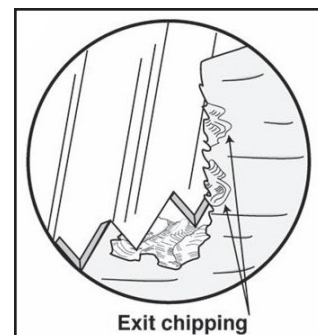

Exit Chipping. Exit chipping is present with few exceptions and even exists in cuts created by saws designed with no front or back to the teeth. Exit chipping will occur at the end of the cutting stroke or on the side of the stroke emphasized by the individual sawing. As a rule, the largest chips of bone are removed on the cutting stroke as the blade exits the bone. (KW)

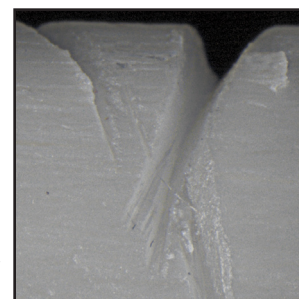

Kerf Flare. Kerf flaring occurs on only one side of the kerf floor. It indicates the ‘handle-end’ of the blade as it expresses the increased movement of the flexible blade as it continually enters the kerf. The opposite end of the kerf floor does not exhibit flaring by virtue of the blade becoming stabilized as it progresses along the kerf. (KF)

REFERENCES CITED

AFTE Criteria for Identification Committee Report

1990 Theory of Identification, Range of Striae Comparison Reports and Modified Glossary Definitions. AFTE Journal 22:275-279.

Andahl, R. O.

1978 The examination of saw marks. Journal of the Forensic Science Society 18:31-46.

Bonte, Wolfgang

1975 Tool marks in bones and cartilage. Journal of Forensic Sciences 20:315-325.

Symes, Steven A.

1992 Morphology of saw marks in human bone: Identification of class characteristics. A Dissertation presented for Doctor of Philosophy Degree, for the Department of Anthropology, University of Tennessee, Knoxville, Tennessee.

EXEMPLAR SAWS

Bone	Blade #	Blade Type	Blade		Distance			Set	Tooth Type	Direction of Cut
			Set Width	Tooth Height	Between Teeth	TPI	PPI			
	1	Rip Saw	0.060	0.165	0.205	4.5	5.5	ALT	CHISEL	PUSH
	2	Arched Pruning Saw	0.080	0.130	0.140	7	8	ALT	CUT	PULL
	3	Backed Saw	0.055	0.045	0.090	11	12	ALT	CHISEL	PUSH
	4	Coping Saw	0.030	0.040	0.045	15	16	WAVY	CHISEL	PUSH
	5	Carpenter Saw	0.050	0.160	0.083	14	15	ALT	CUT	PULL
	6	Hacksaw	0.040	0.020	0.060	18	19	RAKER	CHISEL	PUSH
	7	Stryker Saw	0.045	0.030	0.040	23	24	ALT	CHISEL	P/P
	8	Junior Hacksaw	0.040	0.035	0.015	24	25	WAVY	CHISEL	PUSH

TPI REFERENCE

Distance Between Teeth	TPI	Distance Between Teeth	TPI	Distance Between Teeth	TPI	Distance Between Teeth	TPI
0.02	50.0	0.08	12.5	0.14	7.1	0.2	5.0
0.03	33.3	0.09	11.1	0.15	6.7	0.21	4.8
0.04	25.0	0.1	10.0	0.16	6.3	0.22	4.5
0.05	20.0	0.11	9.1	0.17	5.9	0.23	4.3
0.06	16.7	0.12	8.3	0.18	5.6	0.24	4.2
0.07	14.3	0.13	7.7	0.19	5.3	0.25	4.0

SAW MARK DATA SHEET (NOT FOR CITATION OR QUOTATION) STEVEN A. SYMES

CASE NO: _____ OTHER: _____ DESCRIPTION: _____ BONE: _____

CUT LOCATION: _____ From Prox/Dist end Total cut surfaces: _____

ORIENTATION of cut to bone: [Prox _____ to _____ Dist]
A P L M A P L M

DIRECTION of Saw Progress [False -starts _____ to _____ B-A spur/notch]
A P L M A P L M

DIRECTION of Cutting Stroke [Entrance Shaving _____ to _____ Exit Chipping]
A P L M A P L M

SAW BLADE AND TOOTH:

SIZE tooth width _____ Based on _____
tooth dist _____ thus TPI Based on _____
kerf min width _____ kerf max width _____ Based on _____

SHAPE chisel (rip) _____ cut (cross-cut) _____ Based on _____
flat _____ curved _____ Based on _____
push _____ pull _____ Based on _____

SET alt _____ raker _____ wavy _____ Based on _____

POWER hand _____ power _____ Based on _____

SAW MARK DATA SHEET (NOT FOR CITATION OR QUOTATION) STEVEN A. SYMES

CASE NO: _____ OTHER: _____ DESCRIPTION: _____ BONE: _____

CUT LOCATION: _____ From Prox/Dist end Total cut surfaces: _____

ORIENTATION of cut to bone: [Prox _____ to _____ Dist]
A P L M A P L M

DIRECTION of Saw Progress [False -starts _____ to _____ B-A spur/notch]
A P L M A P L M

DIRECTION of Cutting Stroke [Entrance Shaving _____ to _____ Exit Chipping]
A P L M A P L M

SAW BLADE AND TOOTH:

SIZE tooth width _____ Based on _____

tooth dist _____ thus TPI Based on _____

kerf min width _____ kerf max width _____ Based on _____

SHAPE chisel (rip) _____ cut (cross-cut) _____ Based on _____

flat _____ curved _____ Based on _____

push _____ pull _____ Based on _____

SET alt _____ raker _____ wavy _____ Based on _____

POWER hand _____ power _____ Based on _____

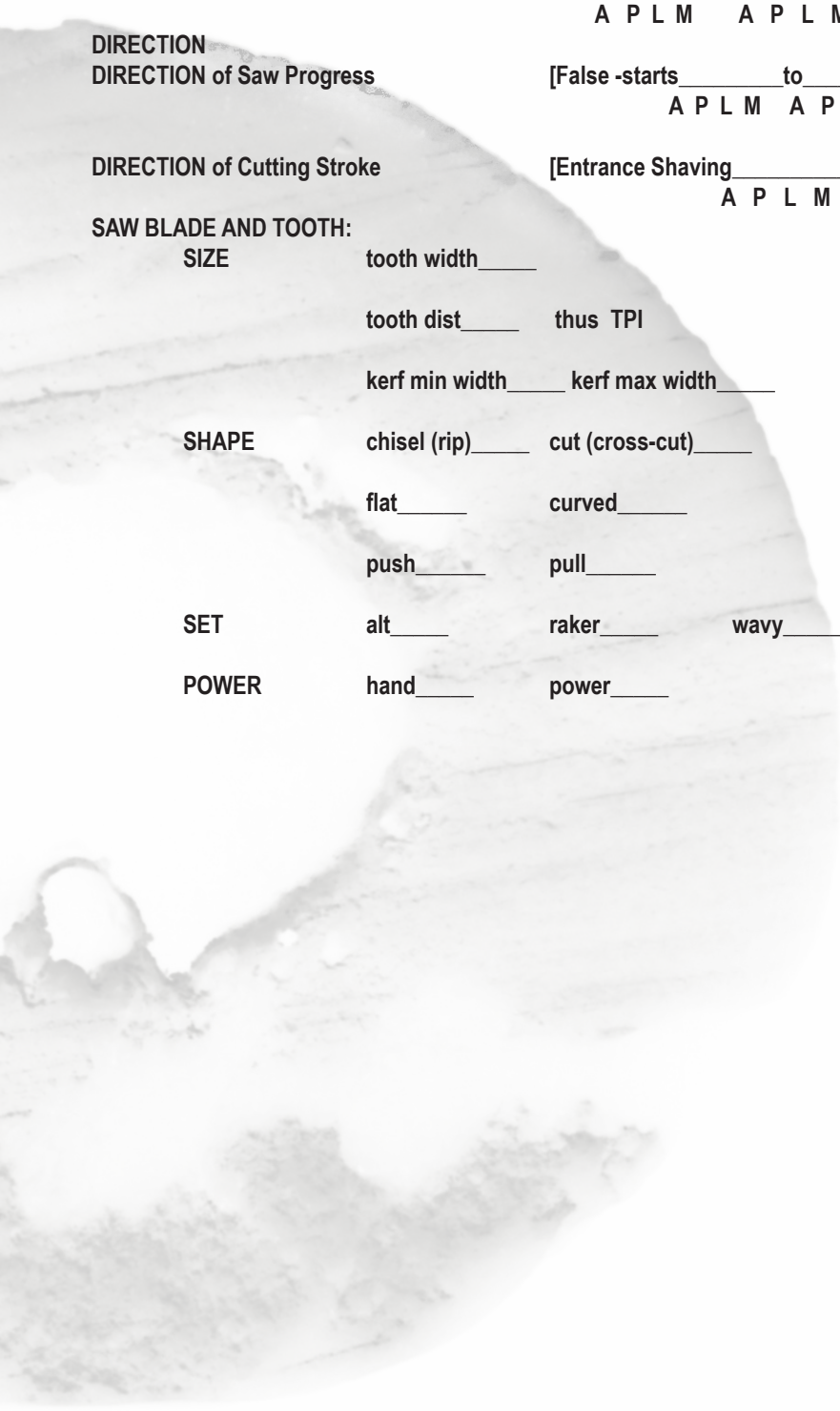

SAW MARK DATA SHEET (NOT FOR CITATION OR QUOTATION) STEVEN A. SYMES

CASE NO: _____ OTHER: _____ DESCRIPTION: _____ BONE: _____

CUT LOCATION: _____ From Prox/Dist end Total cut surfaces: _____

ORIENTATION of cut to bone: [Prox _____ to _____ Dist]
A P L M A P L M

DIRECTION of Saw Progress [False -starts _____ to _____ B-A spur/notch]
A P L M A P L M

DIRECTION of Cutting Stroke [Entrance Shaving _____ to _____ Exit Chipping]
A P L M A P L M

SAW BLADE AND TOOTH:

SIZE tooth width _____ Based on _____

tooth dist _____ thus TPI Based on _____

kerf min width _____ kerf max width _____ Based on _____

SHAPE chisel (rip) _____ cut (cross-cut) _____ Based on _____

flat _____ curved _____ Based on _____

push _____ pull _____ Based on _____

SET alt _____ raker _____ wavy _____ Based on _____

POWER hand _____ power _____ Based on _____



NOTES:



NOTES:

