

UNIVERSITY OF
CALIFORNIA

*Radiation
Laboratory*

TWO-WEEK LOAN COPY

*This is a Library Circulating Copy
which may be borrowed for two weeks.
For a personal retention copy, call
Tech. Info. Division, Ext. 5545*

BERKELEY, CALIFORNIA

UNIVERSITY OF CALIFORNIA

Radiation Laboratory
Berkeley, California

Contract No. W-7405-eng-48

EXPERIMENTS ON ANTIPROTONS:
ANTIPROTON-NUCLEON CROSS SECTIONS

Owen Chamberlain, Donald V. Keller, Ronald Mermod, Emilio Segrè,
Herbert M. Steiner, and Tom Ypsilantis

July 22, 1957

EXPERIMENTS ON ANTIPROTONS:
ANTIPROTON-NUCLEON CROSS SECTIONS

Owen Chamberlain, Donald V. Keller, Ronald Mermod, Emilio Segrè,
Herbert M. Steiner, and Tom Ypsilantis

Radiation Laboratory
University of California
Berkeley, California

July 22, 1957

ABSTRACT

In this paper experiments are reported on annihilation and scattering of antiprotons in H_2O , D_2O , and O_2 . From the data measured it is possible to obtain an antiproton-proton and an antiproton-deuteron cross section at 457 Mev (lab). Further analysis gives the \bar{p} -p and \bar{p} -n cross sections as

104 mb for the \bar{p} -p reaction cross section and

113 mb for the \bar{p} -n reaction cross section.

The respective annihilation cross sections are 89 and 74 mb. The Glauber correction necessary in order to pass from the \bar{p} -d to the \bar{p} -n cross section by subtraction of the \bar{p} -p cross section is unfortunately large and somewhat uncertain. The data are compared with the p-p and \bar{p} -n cross sections and with other results on \bar{p} -p collisions.

EXPERIMENTS ON ANTIPROTONS:
ANTIPROTON-NUCLEON CROSS SECTIONS*

Owen Chamberlain, Donald V. Keller, Ronald Mermod, Emilio Segrè,
Herbert M. Steiner, and Tom Ypsilantis

Radiation Laboratory
University of California
Berkeley, California

July 22, 1957

I. Introduction

In the antiproton studies that were planned and initiated immediately after the discovery of this particle the investigation of the antiproton-nucleon cross section had naturally an important part. In the preceding paper we have described the results obtained up to now in the study of cross sections for complex nuclei; we report here our results on nucleons.

Here also we have endeavored to distinguish between annihilation and scattering cross sections, and we have tried to obtain information not only on the \bar{p} -p but also on the \bar{p} -n cross section. The method used is very similar to the one described in the preceding paper, but the absorber and Cerenkov counter detecting the annihilation were different. If we want to observe the annihilation of antiprotons with protons, the obvious and most direct way--namely, to observe the Cerenkov light in a liquid hydrogen target--is not applicable because the refractive index of liquid hydrogen is too small ($n=1.09$) and most of the annihilation pions do not produce any light. We must then use a hydrogenous substance of suitable refractive index and have recourse to a subtraction method. We chose water, heavy water, and liquid oxygen, and by taking differences we obtain the cross sections of hydrogen, deuterium, and oxygen. The hydrogen-deuterium difference was also analyzed to obtain the \bar{p} -n cross section. Such a subtraction method is inherently delicate from the experimental point of view; moreover, the \bar{p} -n cross section cannot be obtained simply

*Preliminary reports on this work have been given:

E. Segrè, Bull. Am. Phys. Soc. 2, 36 (1957); Am. J. Phys. (in press).
Steiner, Chamberlain, Keller, Rogers, Segrè, Agnew, Wiegand,
and Ypsilantis, Bull. Am. Phys. Soc. 2, 193 (1957).

from the difference between the \bar{p} -d and \bar{p} -p cross sections, because the proton screens the neutron in the deuteron. The correction caused by this effect is unusually large because the antiproton-proton cross section is large, and this adds some uncertainty to the result. On the other hand the only feasible alternative to this procedure seems to be to use an antineutron beam on protons, and this must wait for the development of a suitable antineutron beam.

In Section II we give the experimental details of this investigation, in Section III the results and discussion.

II. Experimental Procedures

The spectrograph used for forming the antiproton beam has been described in the preceding paper.

The absorber and annihilation detector was a stainless steel box 10.75-in. long (Fig. 1), which could contain liquid oxygen, water, or heavy water. The box was thoroughly insulated with Santocel (SiO_2 Powder) of density 0.091 g/cm^3 .

The characteristics of the absorbing media are given in Table I.

Table I. Characteristics of the attenuators.

Material	Thickness ($\cdot N$ of text)	Density (g cm^{-3})	Index of refraction	Energy of beam at center (Mev)
O	$1.170 \times 10^{24} \frac{\text{atoms}}{\text{cm}^2}$	1.142	1.22	457
H ₂ O	$0.915 \times 10^{24} \frac{\text{molecules}}{\text{cm}^2}$	1.00	1.33	457
D ₂ O	$0.910 \times 10^{24} \frac{\text{molecules}}{\text{cm}^2}$	1.105	1.33	457

The windows of the box added 0.23 g/cm^2 of Santocel and 0.33 g/cm^2 of stainless steel. The inside of the absorber box was lined with 1-mil aluminum foil to reflect the Cerenkov light.

Great care was taken to be sure of the thickness of the absorbing substance and to be sure that the changes of temperature in passing from liquid oxygen to water at room temperature did not produce undesirable effects,

such as a change in the characteristics of the photomultipliers or deformations in the containers. We found that the photomultipliers work satisfactorily provided they are not immersed in the liquid oxygen and have a heat shield. We also investigated the transparency of liquid oxygen to the light to which the photomultipliers respond.

In order to obtain antiproton-nucleon cross sections with a statistical accuracy of about 10%, it was necessary to take the data for D_2O , H_2O , and O_2 until 10^4 antiprotons had been incident upon each of these materials. The three absorbers were cycled through several times and data were taken with different voltages on the C** counter. It is possible that some of the annihilations may give small pulses in C** and hence escape detection; for this reason it was important to obtain a bias curve of the pulse height and extrapolated to zero pulse height as indicated in the preceding paper. Figure 2 exemplifies the manner in which the pulse-height distribution for Counter C** was extrapolated to zero pulse height.

The cutoff angles of 14.3° and 20.5° were such that we should expect that the antiprotons that have undergone diffraction scattering are counted as "pass-through". In other words, ours is a bad-geometry arrangement in which we distinguish annihilation from scattering (elastic or inelastic) other than diffraction.

For a black disk the first diffraction minimum occurs at an angle $\theta = 0.61 \lambda/R$, where λ is the wave length and R the radius of the disk. If we take for the radius of the black disk, $R = \sqrt{\sigma_{an}/\pi}$, where σ_{an} is the \bar{p} -p annihilation cross section, our cutoff angle contains more than 90% of the first diffraction peak, even for hydrogen.

The raw data from which the cross sections were calculated are reported in Table II. The data of Table II have been collected photographically in the same way as reported in the preceding paper. At each voltage used in the C** counter we have made a separate extrapolation to zero pulse height in order to correct for annihilations giving small pulses in C**. The numbers reported are the extrapolated numbers. The extrapolation never amounts to more than 7%. It is interesting to note that the results obtained with different voltages on counter C** agree satisfactorily among themselves, as they should. The cross sections of $1/2 O_2$, H_2O , and D_2O and their statistical errors are obtained by using the formulae

$$\sigma(\theta) = \frac{1}{N} \left\{ \ln \left[\frac{I_o}{I(\theta)} \right] \pm \left[\left(\frac{1}{I(\theta)} \right) - \left(\frac{1}{I_o} \right) \right]^{1/2} \right\}$$

and

$$\sigma_{an} = \frac{1}{N} \left\{ \ln \left[\frac{I_o}{I_o - I_{an}} \right] \pm \left[\left(\frac{1}{I_o - I_{an}} \right) - \left(\frac{1}{I_o} \right) \right]^{1/2} \right\},$$

where N is the number of oxygen atoms per square centimeter in the target, or the number of H_2O or D_2O molecules per square centimeter in the target. The other quantities are defined in the caption for Table II.

Table II. Experimental Results: I_o is the number of incident particles, $I(\theta)$ is the number of pass-through particles into the forward cone of half angle θ , I_{an} is the number of annihilations, and $I_{an}(\theta)$ is the number of annihilations in which a charged product is detected in the forward cone of half angle θ .

Target	C** voltage	I_o	$I(14^\circ)$	$I(20^\circ)$	I_{an}	$I_{an}(14^\circ)$	$I_{an}(20^\circ)$
D_2O	1900	3288	1467	1522	1538	320	518
D_2O	2000	5961	2590	2684	2916	668	1090
D_2O	2100	1521	658	714	737	157	237
H_2O	1900	3539	1772	1844	1523	307	505
H_2O	2000	5377	2663	2767	2382	516	825
O_2	2050	6717	3500	3667	2760	704	1000

III. Results and Discussion

The results are shown in Table III. The first three rows give the cross sections for O , H_2O , and D_2O for both antiprotons and protons. The cross sections for positive protons have been measured with the same apparatus as for antiprotons, and agree within about 7 mb with the results of Chen, Leavitt, and Shapiro.¹ From the results of the first three lines of the table we have obtained by subtraction the following antinucleon-nucleon cross sections with their errors.

¹Chen, Leavitt, and Shapiro, Phys. Rev. 103, 211 (1956).

Annihilation cross sections are given by

$$\sigma_{\bar{p}, p}^{\text{an}} = \frac{1}{2} \left[\sigma_{\bar{p}, \text{H}_2\text{O}}^{\text{an}} - \frac{1}{2} \sigma_{\bar{p}, \text{O}_2}^{\text{an}} \right]$$

and

$$" \sigma_{\bar{p}, n}^{\text{an}} " = \frac{1}{2} \left[\sigma_{\bar{p}, \text{D}_2\text{O}}^{\text{an}} - \sigma_{\bar{p}, \text{H}_2\text{O}}^{\text{an}} \right] ;$$

also $\sigma(\theta)$, the total cross section as obtained with a cutoff angle θ , is given by

$$\sigma_{\bar{p}, p}(\theta) = \frac{1}{2} \left[\sigma_{\bar{p}, \text{H}_2\text{O}}(\theta) - \frac{1}{2} \sigma_{\bar{p}, \text{O}_2}(\theta) \right]$$

and

$$" \sigma_{\bar{p}, n}(\theta) " = \frac{1}{2} \left[\sigma_{\bar{p}, \text{D}_2\text{O}}(\theta) - \sigma_{\bar{p}, \text{H}_2\text{O}}(\theta) \right] .$$

The angles θ used in our experiment were 14.3° and 20.5° .

Table III. Attenuation and annihilation cross sections (in mb) for antiprotons and protons.

Substance	$\sigma(14^\circ)$		$\sigma(20^\circ)$		$\frac{\sigma_{\text{an}}}{\bar{p}}$
	\bar{p}	p	\bar{p}	p	
$\frac{1}{2} \text{O}_2$	556±10	292±2	517±10	246±2	453±9
H_2O	763±12	343±2	721±12	295±2	630±11
D_2O	902±11	400±2	862±11	337±2	721±11
H	104±8	25±1	102±8	24±1	89±7
d	174±8	54±2	172±8	45±2	135±7
"N"	70±8	29±1	70±8	21±1	46±8
N	113		113		74

The cross sections labeled "N" in Table III are simply the differences between d and H cross sections. In order to obtain the true \bar{p} -n cross section a substantial correction has to be applied in order to take account of the shielding of one nucleon by the other in the deuteron. This correction has been calculated by Glauber.² Calling the correction

$$\delta\sigma = \sigma_n - \sigma_n = \sigma_d - \sigma_p - \sigma_n,$$

Glauber gives

$$\delta\sigma = \left(\frac{1}{2\pi}\right) \sigma_p \sigma_n \langle r^{-2} \rangle_d,$$

where all the cross sections are absorption (annihilation) cross sections. Here $\langle r^{-2} \rangle_d$ is the average value of $1/r^2$ over the deuteron wave function. If we take the value of Chen, Leavitt, and Shapiro,¹ then we have

$$(1/2\pi) \langle r^{-2} \rangle_d = 0.00732 \text{ mb}^{-1}.$$

This form of the correction is valid only for $(\delta\sigma/\sigma_p) \ll 1$. This is not the case for antiprotons, and a more elaborate correction procedure becomes necessary. For equal neutron and proton cross sections this also has been worked out by Glauber, and the same method has been used by Blair³ to extend Glauber's results to unequal cross sections. Glauber and Blair give numerical results which applied to our case give the values of the last line of Table III. It is hard to assess the error of these cross sections. There is about 14 mb of purely statistical error, but the Glauber correction is large and it is also somewhat uncertain.

The calculation of the Glauber correction is based on the following assumptions:

(a) that χ is much less than interaction range of the antiproton. In our case $\chi \sim 0.2 \times 10^{-13}$ cm, and we assume an interaction range of $\hbar/mc = 1.4 \times 10^{-13}$ cm.

(b) Energy transfers from antiprotons to nucleons in the deuteron are neglected, which corresponds to the statement that the internal motions in the deuteron must be slow with respect to the velocity of the antiproton relative to the nucleon. Also this condition is reasonably satisfied in our case.

²R. J. Glauber, Phys. Rev. 100, 242 (1955).

³J. S. Blair, (University of Washington), private communication.

Because our measurements show that the \bar{p} interaction ranges are not small compared with the size of the deuteron, an accurate calculation of the shielding effect requires knowledge of the interaction radii and opacity distributions. However, information from which conclusions about these could be reached is still lacking. Measurements of the scattering cross section, for example, would furnish an estimate of the interaction radii. The only information we have on scattering, $\sigma_{\text{scatt}} \ll \sigma_{\text{reaction}}$, indicates that the nucleon should be described as a gray sphere of radius larger than the black sphere with the same σ_{reaction} .

In addition to the parameters mentioned above, the magnitude of the Glauber correction depends on the choice of the deuteron eigenfunction, especially in the region where the two nucleons in the deuteron are in close proximity. In calculating the present correction we have used a Hulthén potential as described in Reference 2.

In conclusion we must say that $\delta\sigma = 43$ mb should probably be considered as an upper limit to the Glauber correction. A better estimate will be possible only after measurement of the \bar{p} -p scattering cross section.

With these corrections the \bar{p} -n and \bar{p} -p cross sections appear to be about equal in both the annihilation and the scattering part. If we admit charge independence and use isotopic spin formalism we note that the \bar{p} -p system may with equal probability, be in a singlet or triplet isotopic spin state, whereas the \bar{p} -n system is always in a triplet isotopic spin state. If we call σ_1 the reaction cross section for triplet states and σ_0 the analogous cross sections for the singlet states we have

$$\sigma_{p\bar{p}} = 1/2 (\sigma_1 + \sigma_0),$$

$$\sigma_{n\bar{p}} = \sigma_1.$$

If the two annihilation cross sections are indeed equal we have $\sigma_1 = \sigma_0$. Better accuracy is needed to confirm this relation. There is a relation between the charge-exchange cross section and the \bar{p} -p, \bar{p} -n cross sections

$$\left(\frac{d\sigma}{d\omega}\right)_{p\bar{p} \rightarrow n\bar{n}}(0^\circ) \geq \left(\frac{k}{4\pi}\right)^2 \left\{ \sigma_{\text{total}}(\bar{p}n) - \sigma_{\text{total}}(\bar{p}p) \right\}^2,$$

in which the differential charge-exchange cross section is taken in the forward direction. For the value estimated in the following paper for this quantity, we find

$$\left| \sigma_{\text{tot}}(\bar{p}n) - \sigma_{\text{tot}}(\bar{p}p) \right| \leq 50 \text{ mb},$$

which is amply satisfied by our results.

Our results should be compared with results obtained in good geometry by Cork, Lambertson, Piccioni, and Wenzel.⁴ They find (we interpolated slightly), for an energy of 450 Mev, a total \bar{p} -p cross section of 99 ± 7 mb. In our experiments the diffraction scattering does not appear because we use a $\theta_c = 14.3^\circ$, and if we take the two results at their face value we should conclude that there is only (-5 ± 11) mb of cross section corresponding to scattering between 4° and 14° . This result, even taking account of the errors, does not seem to leave enough leeway for the expected diffraction scattering. Also, the two results can be reconciled with the relation

$$\text{Im } f(0) = \frac{k}{4\pi} \sigma_{\text{total}}$$

only by the assumption of a very precipitous decrease of $f(\theta)$ with increasing θ .

The clarification of this point can be obtained by further experiments giving a detailed measurement of the forward scattering as a function of angle.

The cross sections in Table III have been used to calculate cross sections of complex nuclei by an optical model with satisfactory agreement.

A particular model has been tried by Koba and Takeda⁵ to see whether the large observed antinucleon-nucleon cross sections could be reconciled with theory. Their model consists essentially of a black sphere of radius $1/3 (\hbar/m_\pi c) = 0.47 \times 10^{-13}$ cm surrounded by a rectangular attractive potential well 70 Mev deep and of radius $\hbar/m_\pi c = 1.4 \times 10^{-13}$ cm. Their model, at least in its original form, does not seem entirely adequate because their calculated annihilation cross sections seem too small and their calculated

⁴Cork, Lambertson, Piccioni, and Wenzel, UCRL-3650, Feb. 1957 (to be published in Phys. Rev. 107, July 1, 1957)

⁵J. Koba (Kyoto Univ.) and G. Takeda (Brookhaven National Lab), private communication on Antiproton-proton Scattering, Oct. 1956.

scattering cross sections somewhat too large. As yet we know of no model that is in full agreement with the results discussed.

We wish to thank Dr. R. J. Glauber for his instructive discussions on the corrections to the \bar{p} -n cross section.

Figure Captions

Fig. 1. C** counter used to distinguish annihilation from scattering in antiproton collisions with H_2O , D_2O and O_2 .

Fig. 2. Pulse-height histogram for 1.175-Bev/c antiprotons on D_2O at C** voltage of 2000. This particular case is for annihilation events in which a charged particle did not count in counter S2. The integral of the histogram starting from the right is plotted above, showing the extrapolation to zero pulse height.

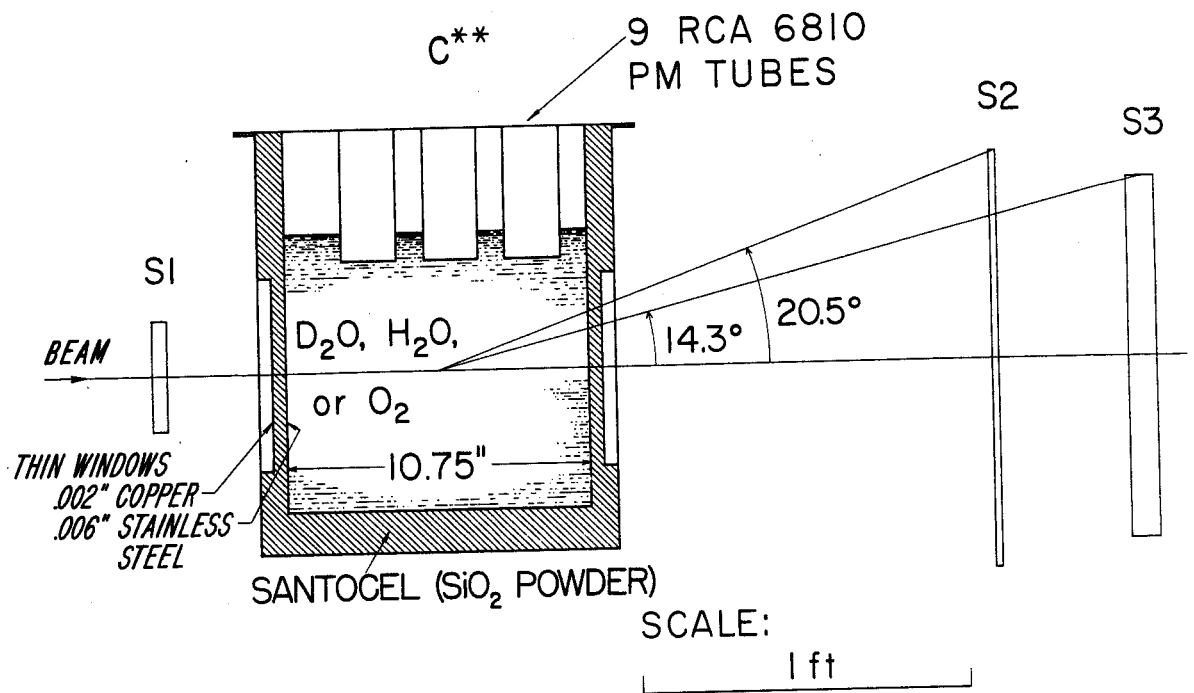

MD-12743

Fig. 1

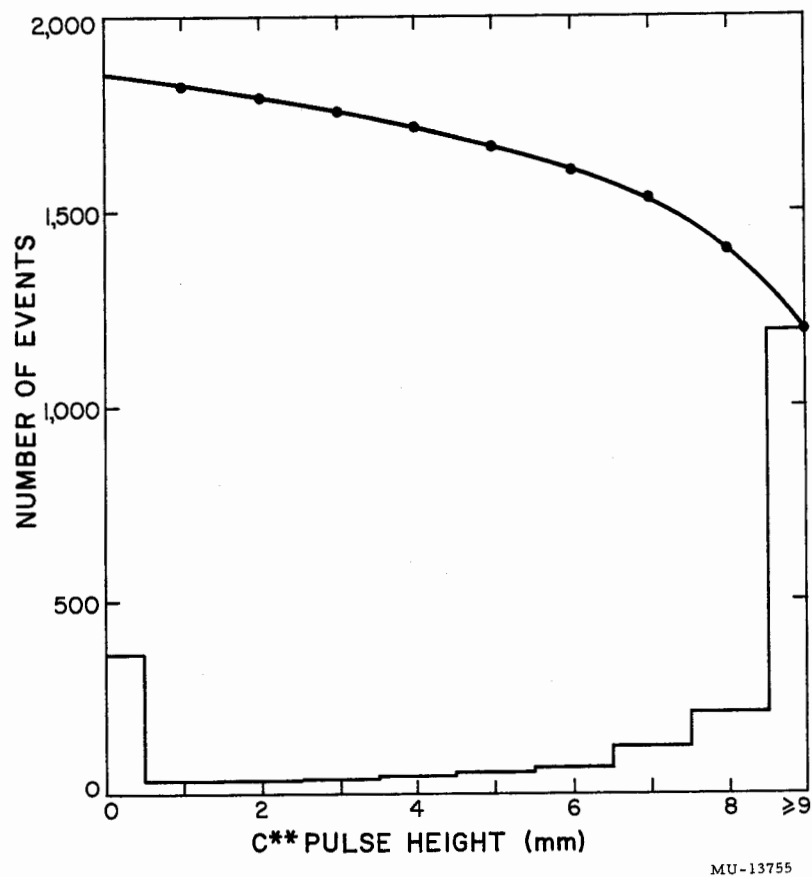

Fig. 2.