

International Shipping Labels

USPS Web Tools™

Application Programming Interface

Reference

Document Version 4.1 (01/22/2012)



To Our Customers

In registering for use of the USPS Web Tools™ (Web Tools), you received a user ID that will allow you to begin sending calls to the server when you are ready. Any additional information or contact with you will occur as indicated on the registration form, please return to the Web Tools [eCommerce API Technical Guides site](#) for the most recent documentation from any of the Web Tools.

If you require technical support, contact the USPS Internet Customer Care Center (ICCC). This office is manned from 7:00 AM to 11:00 PM EST daily.

E-mail address: uspstechsupport@esecurecare.net

Telephone: 1-800-344-7779 (7:00 AM to 11:00 PM EST daily)

USPS Customer Commitment

The United States Postal Service fully understands the importance of providing information and service anytime day or night to your Internet and e-commerce customers. For that reason, the USPS is committed to providing 24 x 7 service from our Web Tools servers, 365 days a year.

Trademarks

Express Mail, First-Class Mail, Global Express Mail, GXG, Global Priority Mail, Parcel Post, Parcel Select, Priority Mail, Express Mail International, First Class Mail International, Priority Mail International, USPS, and ZIP + 4 are registered trademarks of the U.S. Postal Service.

Delivery Confirmation, Global Express Guaranteed, International Parcel Post, Priority Mail Global Guaranteed, Signature Confirmation, USPS Web Tools, and ZIP Code are trademarks of the U.S. Postal Service.

Microsoft and Visual Basic are registered trademarks of Microsoft Corporation.

Adobe Acrobat is a trademark of Adobe Systems Incorporated.

DUNS is a registered trademark of Dun & Bradstreet.

©Copyright 2012 United States Postal Service

Table of Contents

1	Introduction.....	5
2	Express Mail International API.....	5
2.1	Express Mail International Request.....	5
2.1.1	API Signature.....	5
2.1.2	Request Diagram.....	6
2.1.3	Request Parameters.....	13
2.1.4	Request Example.....	25
2.2	Express Mail International Response.....	29
2.2.1	Response Diagram.....	29
2.2.2	Response Parameters.....	31
2.2.3	Tagged Label Diagram.....	33
2.2.4	Response Example.....	34
3	Priority Mail International API.....	35
3.1	Priority Mail International Request.....	35
3.1.1	API Signature.....	35
3.1.2	Request Diagram.....	36
3.1.3	Request Parameters.....	44
3.1.4	Request Example.....	59
3.2	Priority Mail International Response.....	62
3.2.1	Response Diagram.....	62
3.2.2	Response Parameters.....	64
3.2.3	Tagged Label Diagram.....	66
3.2.4	Response Example.....	67
4	First Class Mail International API.....	68

4.1	First Class Mail International Request	68
4.1.1	API Signature.....	68
4.1.2	Request Diagram.....	69
4.1.3	Request Parameters.....	75
4.1.4	Request Example.....	85
4.2	First Class Mail International Response	88
4.2.1	Response Diagram.....	88
4.2.2	Response Parameters.....	89
4.2.3	Tagged Label Diagram.....	90
4.2.4	Response Example.....	91

1 Introduction

This document contains a Reference Guide to the International Shipping Labels APIs. See the Developer's Guide to Web Tools APIs to learn the administrative process for gaining access to the Web Tools APIs as well as the basic mechanism for calling the APIs and processing the results. The Developer's Guide also contains information on testing and trouble-shooting.

For label specifications such as package dimensions, delivery information, etc., please refer to the International Mail Manual (IMM) at <http://pe.usps.com/>.

2 Express Mail International API

2.1 Express Mail International Request

The table below presents the XML input tags for generating Live requests and the restrictions on the values allowed. An error message will be returned if an incorrect value is entered. Also, be aware of the maximum character amounts allowed for some tags. If the user enters more than those amounts, an error will not be generated. **The Web Tool will simply pass in the characters up to the maximum amount allowed and disregard the rest.** This is important since the resulting value could prevent a correct response.

When building the XML request, pay particular attention to the **order and case** for tags. An error message will be returned if an incorrect value is entered. Remember that all data and attribute values in this document are for illustration purposes and are to be replaced by your actual values. For instance, a line of sample code may be:

`<ZipDestination>12345</ZipDestination>`

In this instance, you will replace "12345" with the destination ZIP Code for the domestic-bound package.

2.1.1 API Signature

<i>Scheme</i>	<i>Host</i>	<i>Path</i>	<i>API</i>	<i>XML</i>
https://	secure.shippingapis.com	/ShippingAPI.dll	?API=ExpressMailIntl	&XML=(see below)
https://	secure.shippingapis.com	/ShippingAPI.dll	?API=ExpressMailIntlCertify	&XML=(see below)

2.1.2 Request Diagram

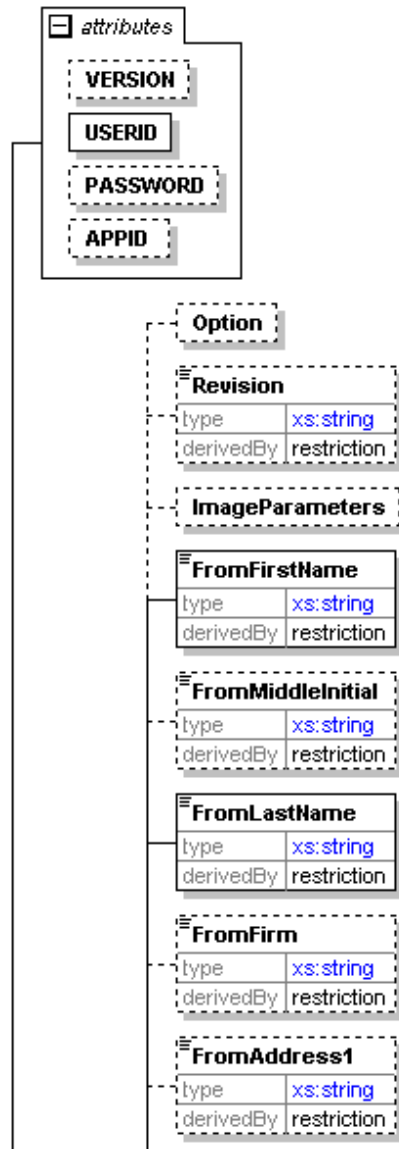

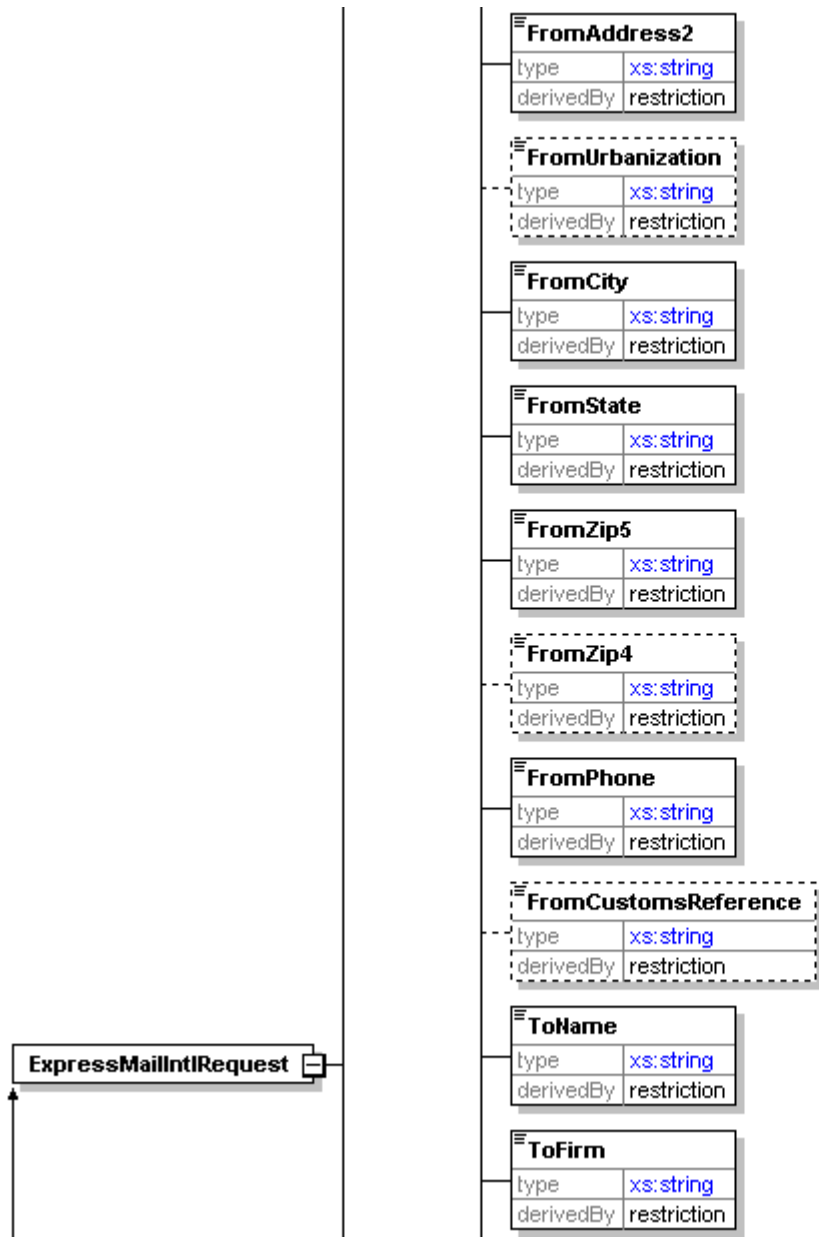

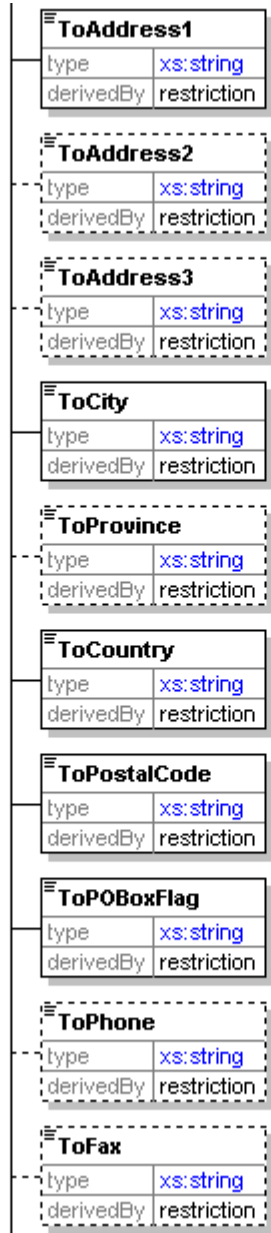

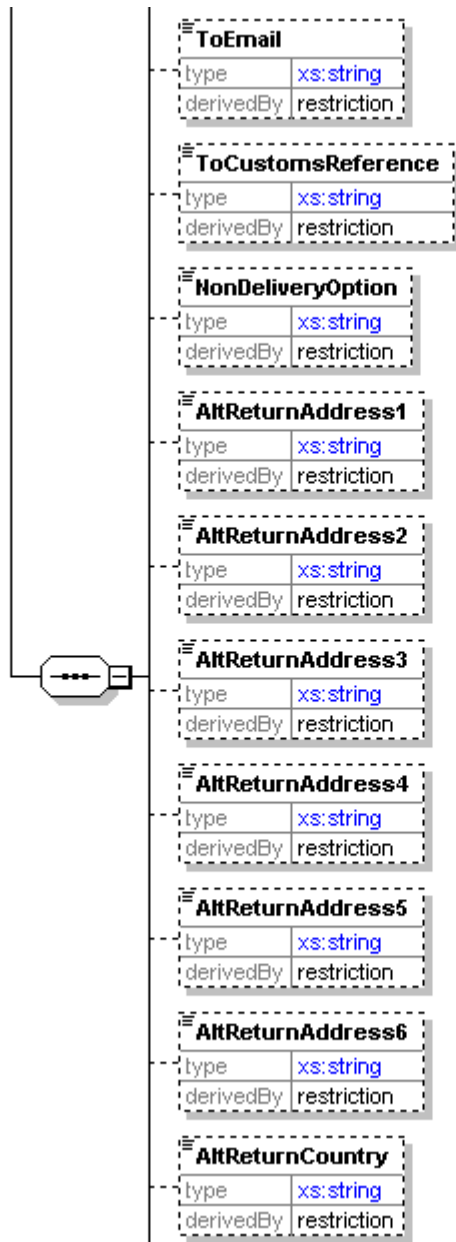

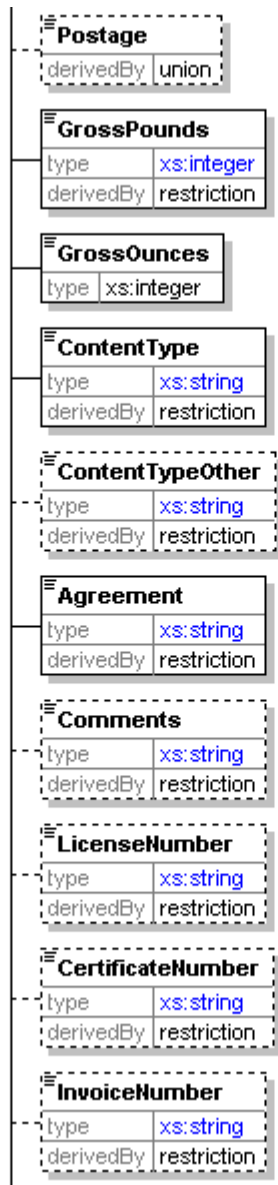

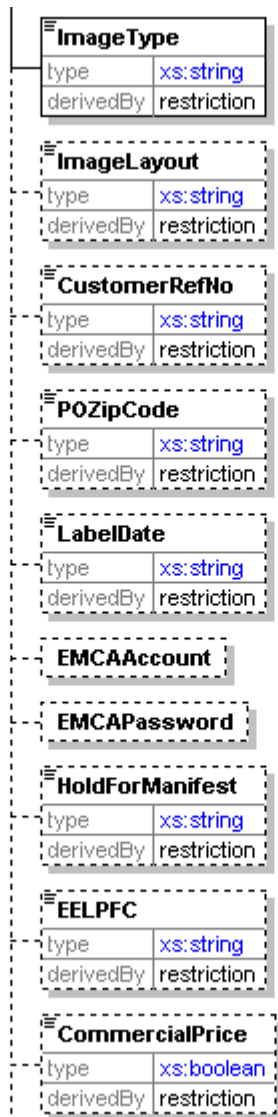

ExpressMailIntlCertifyRequest

Size	
type	xs:string
derivedBy	restriction

Length	
type	xs:decimal
derivedBy	restriction

Width	
type	xs:decimal
derivedBy	restriction

Height	
type	xs:decimal
derivedBy	restriction

Girth	
type	xs:decimal
derivedBy	restriction

2.1.3 Request Parameters

Tag Name	Occurs	Description	Type	Validation
ExpressMailIntlRequest	required once		(group)	
ExpressMailIntlRequest / @USERID	required	This attribute specifies your Web Tools ID. See the Developer's Guide for information on obtaining your USERID.	string	
ExpressMailIntlRequest / @PASSWORD	optional	For backward-compatibility; not validated.	string	
ExpressMailIntlRequest / Option	optional	For future use.	empty	
ExpressMailIntlRequest / Revision	optional	Use of value 2 required as of January 2011. For example: <Revision>2</Revision>	string	minLength=0 pattern=\d{1} pattern=
ExpressMailIntlRequest / ImageParameters	optional	For future use.	empty	
ExpressMailIntlRequest / FromFirstName	required once	First and Last Name must be sent. Maximum Length: 32 characters total for First, Middle, and Last Names with space after first and middle name. For example: <FromFirstName>John</FromFirstName>	string	maxLength=30 minLength=1 Restriction enforced via truncation
ExpressMailIntlRequest / FromMiddleInitial	optional	First and Last Name must be sent. Maximum Length: 32 characters total for First, Middle, and Last Names with space after first and middle name. For example: <FromMiddleInitial>L</FromMiddleInitial>	string	maxLength=1 Restriction enforced via truncation
ExpressMailIntlRequest / FromLastName	required once	First and Last Name must be sent. Maximum Length: 32 characters total for First, Middle, and Last Names with space after first and middle name. For example: <FromLastName>Doe</FromLastName>	string	maxLength=30 minLength=1 Restriction enforced via truncation

Tag Name	Occurs	Description	Type	Validation
ExpressMailIntlRequest / FromFirm	optional	Firm name; may be left blank. For example: <FromFirm></FromFirm>	string	maxLength=32 Restriction enforced via truncation
ExpressMailIntlRequest / FromAddress1	optional	Use this tag for a suite or apartment number only. Either Address1 or Address2 is required. For example: <FromAddress1/>	string	maxLength=32 Restriction enforced via truncation
ExpressMailIntlRequest / FromAddress2	required once	Use this tag for the primary address line. For example: <FromAddress2>10 Elm Street</FromAddress2>	string	maxLength=32 Restriction enforced via truncation
ExpressMailIntlRequest / FromUrbanization	optional	Use this tag for Puerto Rico only. ZIP Code prefixes 006 to 009, if area is so designated. For example: <FromUrbanization>URB Caparra Ter</FromUrbanization>	string	maxLength=32
ExpressMailIntlRequest / FromCity	required once	For example: <FromCity>Anytown</FromCity>	string	maxLength=16 minLength=1
ExpressMailIntlRequest / FromState	required once	Use 2-letter USPS abbreviation. For example: <FromState>ST</FromState>	string	length=2
ExpressMailIntlRequest / FromZip5	required once	Input tag exactly as presented, not all caps. 5 digits required. For example: <FromZip5>01234</FromZip5>	string	whiteSpace=collapse length=5 pattern=\d{5}
ExpressMailIntlRequest / FromZip4	optional	Input tag exactly as presented, not all caps. If value is entered, 4 digits required. This is the ZIP+4 extension. For example: <FromZip4>5678</FromZip4>	string	whiteSpace=collapse length=4 pattern=\d{4}
ExpressMailIntlRequest / FromPhone	required once	10 digits required (including area code), with no punctuation. Use format: 2125551234 For example: <FromPhone>5555555555</FromPhone>	string	whiteSpace=collapse length=10 pattern=\d{10}

Tag Name	Occurs	Description	Type	Validation
ExpressMailIntlRequest / FromCustomsReference	optional	Enter a value for the "Sender's Customs Reference" that will appear on the label. The text entered is any reference number that the sender wishes to use. For example: <FromCustomsReference></FromCustomsReference>	string	maxLength=30
ExpressMailIntlRequest / ToName	required once	Enter a value for the recipient's name. For example: <ToName>Ms. C. P. Apple</ToName>	string	maxLength=36
ExpressMailIntlRequest / ToFirm	required once	Enter a value for the recipient's firm. For example: <ToFirm></ToFirm>	string	maxLength=36
ExpressMailIntlRequest / ToAddress1	required once	Three address lines are provided, but only 1 is required. Use as many as needed for complete address. For example: <ToAddress1> Apartado 3068</ToAddress1>	string	maxLength=36 minLength=1
ExpressMailIntlRequest / ToAddress2	optional	Three address lines are provided, but only 1 is required. Use as many as needed for complete address. For example: <ToAddress2></ToAddress2>	string	maxLength=36
ExpressMailIntlRequest / ToAddress3	optional	Three address lines are provided, but only 1 is required. Use as many as needed for complete address. For example: <ToAddress3></ToAddress3>	string	maxLength=36
ExpressMailIntlRequest / ToCity	required once	Recipient's city. For example: <ToCity>PUERTO VALLARTA</ToCity>	string	maxLength=18 minLength=1
ExpressMailIntlRequest / ToProvince	optional	Enter the province for the recipient. For example: <ToProvince>JALISCO</ToProvince>	string	maxLength=9

Tag Name	Occurs	Description	Type	Validation
ExpressMailIntlRequest / ToCountry	required once	The country name entered must match an entry from the USPS-approved International Index of Countries and Localities. See the Index of Countries and Localities . Using a country name not on the list will result in a request failure. For example: <ToCountry>MEXICO</ToCountry>	string	minLength=1
ExpressMailIntlRequest / ToPostalCode	required once	Enter the postal code for the recipient. For example: <ToPostalCode>46807</ToPostalCode>	string	maxLength=9
ExpressMailIntlRequest / ToPOBoxFlag	required once	Indicates whether or not the To Address is a Post Office Box. For example: <ToPOBoxFlag>N</ToPOBoxFlag>	string	enumeration=Y enumeration=N
ExpressMailIntlRequest / ToPhone	optional	No format checking is done on international phone numbers. Required when <ToPOBoxFlag>Y</ToPOBoxFlag> For example: <ToPhone>011 52 (322) 222-0069</ToPhone>	string	maxLength=30 Restriction enforced via truncation
ExpressMailIntlRequest / ToFax	optional	No format checking is done on international fax numbers. For example: <ToFax>011 52 (322) 222-0074</ToFax>	string	maxLength=30 Restriction enforced via truncation
ExpressMailIntlRequest / ToEmail	optional	Complete valid e-mail address is required if tag is used. For example: <ToEmail>cpapple@email.com</ToEmail>	string	maxLength=30 whiteSpace=collapse pattern=([w\-\.\.]+)@(([w-]+\.\.+) [a-zA-Z]{2,4}) Restriction enforced via truncation
ExpressMailIntlRequest / ToCustomsReference	optional	Enter a value for the "Importer's Customs Reference" that will appear on the label. The text entered is any reference number that the recipient wishes to use. For example: <ToCustomsReference>Order #23432</ToCustomsReference>	string	maxLength=28 Restriction enforced via truncation

Tag Name	Occurs	Description	Type	Validation
ExpressMailIntlRequest / NonDeliveryOption	optional	In case package is undeliverable, enter one of the following: "RETURN" for package to be returned to <FromAddress> above. "REDIRECT" to return package to address specified below in <AltReturnAddress> tags. "ABANDON" to dispose of undeliverable package. For example: <NonDeliveryOption>RETURN</NonDeliveryOption>	string	enumeration=RETURN enumeration=REDIRECT enumeration=ABANDON
ExpressMailIntlRequest / AltReturnAddress1	optional	Valid only with the "REDIRECT" value with the <NonDeliveryOption> tag. Six address lines are provided but only one is required. Use as many as needed for complete address. For example: <AltReturnAddress1></AltReturnAddress1>	string	maxLength=30 Restriction enforced via truncation
ExpressMailIntlRequest / AltReturnAddress2	optional	Valid only with the "REDIRECT" value with the <NonDeliveryOption> tag. Six address lines are provided but only one is required. Use as many as needed for complete address. For example: <AltReturnAddress2></AltReturnAddress2>	string	maxLength=30 Restriction enforced via truncation
ExpressMailIntlRequest / AltReturnAddress3	optional	Valid only with the "REDIRECT" value with the <NonDeliveryOption> tag. Six address lines are provided but only one is required. Use as many as needed for complete address. For example: <AltReturnAddress3></AltReturnAddress3>	string	maxLength=30 Restriction enforced via truncation
ExpressMailIntlRequest / AltReturnAddress4	optional	Valid only with the "REDIRECT" value with the <NonDeliveryOption> tag. Six address lines are provided but only one is required. Use as many as needed for complete address. For example: <AltReturnAddress4></AltReturnAddress4>	string	maxLength=30 Restriction enforced via truncation

Tag Name	Occurs	Description	Type	Validation
ExpressMailIntlRequest / AltReturnAddress5	optional	Valid only with the "REDIRECT" value with the <NonDeliveryOption> tag. Six address lines are provided but only one is required. Use as many as needed for complete address. For example: <AltReturnAddress5></AltReturnAddress5>	string	maxLength=30 Restriction enforced via truncation
ExpressMailIntlRequest / AltReturnAddress6	optional	Valid only with the "REDIRECT" value with the <NonDeliveryOption> tag. Six address lines are provided but only one is required. Use as many as needed for complete address. For example: <AltReturnAddress6></AltReturnAddress6>	string	maxLength=30 Restriction enforced via truncation
ExpressMailIntlRequest / AltReturnCountry	optional	Required when <NonDeliveryOption>REDIRECT</NonDeliveryOption> and required to be equal to <ToCountry> For Example: <AltReturnCountry>MEXICO</AltReturnCountry>	string	
ExpressMailIntlRequest / Container	optional	Use <Container>FLATRATEENV</Container> or <Container>LEGALFLATRATEENV</Container> for flat rate envelopes. Otherwise, use to specify special containers or container attributes that may affect postage. Note: RECTANGULAR or NONRECTANGULAR must be indicated when <Size>LARGE</Size>.	string	default=VARIABLE enumeration=VARIABLE enumeration=FLATRATEENV enumeration=LEGALFLATRATEENV enumeration=FLATRATEBOX enumeration=RECTANGULAR enumeration=NONRECTANGULAR
ExpressMailIntlRequest / ShippingContents	required once		(group)	
ExpressMailIntlRequest / ShippingContents / ItemDetail	required once repeating up to 30 times		(group)	

Tag Name	Occurs	Description	Type	Validation
ExpressMailIntlRequest / ShippingContents / ItemDetail / Description	required once	Description of the item. For example: <Description>Policy guidelines document</Description>	string	maxLength=56 minLength=1 whiteSpace=collapse
ExpressMailIntlRequest / ShippingContents / ItemDetail / Quantity	required once	Quantity of the item. Integer value required. For example: <Quantity>1</Quantity>	integer	whiteSpace=collapse minExclusive=0
ExpressMailIntlRequest / ShippingContents / ItemDetail / Value	required once	The data entered with this tag provides the value of the set of items. If the item is 2 boxes of 50 pens and the value of each box is \$10.00, "20.00" (2 boxes x \$10.00) should be entered. If the value of each pen is .25 then "25.00" (100 pens x .25) should be entered. For example: <Value>55.00</Value>	decimal	whiteSpace=collapse minExclusive=0
ExpressMailIntlRequest / ShippingContents / ItemDetail / NetPounds	required once	Provide the pounds component of the weight of the individual item listed with <Description>. For example: <NetPounds>1</NetPounds>	integer	whiteSpace=collapse
ExpressMailIntlRequest / ShippingContents / ItemDetail / NetOunces	required once	Provide the ounces component of the weight of the individual item listed with <Description>. For example: <NetOunces>5</NetOunces>	integer	
ExpressMailIntlRequest / ShippingContents / ItemDetail / HSTariffNumber	required once	For commercial items only. If known, the HS tariff number (6-digit) must be based on the Harmonized Commodity Description and Coding System developed by the World Customs Organization. For example: <HSTariffNumber>490110</HSTariffNumber>	string	whiteSpace=collapse maxLength=6 pattern=\d{0,6}

Tag Name	Occurs	Description	Type	Validation
ExpressMailIntlRequest / ShippingContents / ItemDetail / CountryOfOrigin	required once	For commercial items only. Country of Origin means the country where the goods originated, e.g. were produced, manufactured, or assembled. It is recommended you supply this information and attach an invoice to the outside to accelerate customs clearance in processing the items. The country name entered must match an entry from the USPS-approved International Index of Countries and Localities or be "United States". http://pe.usps.gov/text/lmm/immctry.htm – click on the link for “International Country Listings”. Using a country name not on the list will result in a request failure. For example: <CountryOfOrigin>United States</CountryOfOrigin>	string	
ExpressMailIntlRequest / InsuredNumber	optional	For backward-compatibility; not validated.	string	
ExpressMailIntlRequest / InsuredAmount	optional	Use this tag for entering an insurance amount, if known. For example: <InsuredAmount>100.00</InsuredAmount>	empty	length=0
ExpressMailIntlRequest / Postage	optional	Use this tag for entering a postage amount, if known. If the tag is present, but the value is blank, the postage will be automatically calculated. For example: <Postage></Postage>	empty	length=0
ExpressMailIntlRequest / GrossPounds	required once	Gross pounds and ounces together represent the total package weight, including packing material. For example, a package weighing 3 lbs 8 ounces would have "3" entered here and "8" entered with the <GrossOunces> tag. The Web Tool will check for maximum shipping weight of 70 pounds. Allowable weight may change based on the service used to send package and the destination country. For example: <GrossPounds>4</GrossPounds>	integer	whiteSpace=collapse
ExpressMailIntlRequest / GrossOunces	required once	Enter the ounces component of the total package weight with this tag. For example: <GrossOunces>0</GrossOunces>	integer	

Tag Name	Occurs	Description	Type	Validation
ExpressMailIntlRequest / Content Type	required once	Specifies the content of the package or envelope. For example: <ContentType>DOCUMENTS</ContentType>	string	enumeration=MERCHANDISE enumeration=SAMPLE enumeration=GIFT enumeration=DOCUMENTS enumeration=RETURN enumeration=OTHER
ExpressMailIntlRequest / ContentTypeOther	optional	Required when <ContentType>OTHER<ContentType>.	string	maxLength=15 whiteSpace=collapse
ExpressMailIntlRequest / Agreement	required once	Requires a value of Y to print <FromFirstName/> and <FromLastName/> in Signature Box along with Current Date (Central Time USA). Any other value returns an error.	string	enumeration=Y enumeration=N
ExpressMailIntlRequest / Comments	optional	Enter any comments. For example: <Comments></Comments>	string	maxLength=76
ExpressMailIntlRequest / LicenseNumber	optional	Enter license number, if known or if included in package. For example: <LicenseNumber>LIC-24356879</LicenseNumber>	string	maxLength=24
ExpressMailIntlRequest / CertificateNumber	optional	Enter certificate number, if known or if included in package. For example: <CertificateNumber>CERT-97865342</CertificateNumber>	string	maxLength=24
ExpressMailIntlRequest / InvoiceNumber	optional	Enter invoice number, if known or if included in package. For example: <InvoiceNumber>INV-040903</InvoiceNumber>	string	maxLength=24
ExpressMailIntlRequest / ImageType	required once	For example: <ImageType>PDF</ImageType>	string	enumeration=PDF enumeration=TIF enumeration=NONE
ExpressMailIntlRequest / ImageLayout	optional	See section 2.2 Form Output Layout Control. For example: <ImageLayout>TRIMONEPERFILE</ImageLayout>	string	default=ONEPERFILE enumeration=ONEPERFILE enumeration=ALLINONEFILE enumeration=TRIMONEPERFILE enumeration=TRIMALLINONEFILE

Tag Name	Occurs	Description	Type	Validation
ExpressMailIntlRequest / CustomerRefNo	optional	Written to Postal Manifest Detail record. For example: <CustomerRefNo>Ref #369246</CustomerRefNo>	string	maxLength=30
ExpressMailIntlRequest / POZipCode	optional	ZIP of Post Office where mailed if different from <FromZip5/>. Written to Postal Manifest Detail record. Must be valid ZIP Code. For example: <POZipCode>00962</POZipCode>	string	whiteSpace=collapse length=5 pattern=\d{5}
ExpressMailIntlRequest / LabelDate	optional	Date the mail will enter the mail stream. No more than 3 days in the future. Default is day of request. For example: <LabelDate>09/28/2010</LabelDate>	string	whiteSpace=collapse maxLength=10 pattern=\d{1,2}/\d{1,2}/\d{1,2}(\d\d)?
ExpressMailIntlRequest / EMCAAccount	optional	For future use.	empty	
ExpressMailIntlRequest / EMCAPassword	optional	For future use.	empty	
ExpressMailIntlRequest / HoldForManifest	optional	Restricted use. Holds manifest record for possible inclusion in SCAN request.	string	enumeration=Y enumeration=N
ExpressMailIntlRequest / EELPFC	optional repeating up to 1 times	Exemption and Exclusion Legend or PFC Code. Please refer to the International Mail Manual for further information - http://pe.usps.gov/text/imm/immc5_007.htm . For example: <EELPFC>30.37a</EELPFC>	string	whiteSpace=collapse minLength=0 maxLength=35
ExpressMailIntlRequest / CommercialPrice	optional	Indicates if commercial-base price should be returned. For commercial-base price eligibility, please reference the Domestic Mail Manual at http://pe.usps.com/ . For example: <CommercialPrice>False</CommercialPrice>	boolean	default=false

Tag Name	Occurs	Description	Type	Validation
ExpressMailIntlRequest / Size	optional	<p>Use in conjunction with Revision tag with value of 2 to indicate and trigger new functionality.</p> <p>Defined as follows: REGULAR: Package dimensions are 12" or less; LARGE: Any package dimension is larger than 12".</p> <p>For example: <Size>REGULAR</Size></p>	string	whiteSpace=collapse enumeration=LARGE enumeration=REGULAR
ExpressMailIntlRequest / Length	optional	<p>Use in conjunction with Revision tag with value of 2 to indicate and trigger new functionality.</p> <p>Value must be numeric. Units are inches. Required when ExpressMailIntlRequest/Size is LARGE.</p> <p>For example: <Width>5.5</Width></p>	decimal	minExclusive=0.0 totalDigits=10
ExpressMailIntlRequest / Width	optional	<p>Use in conjunction with Revision tag with value of 2 to indicate and trigger new functionality.</p> <p>Value must be numeric. Units are inches. Required when ExpressMailIntlRequest/Size is LARGE.</p> <p>For example: <Length>11</Length></p>	decimal	minExclusive=0.0 totalDigits=10
ExpressMailIntlRequest / Height	optional	<p>Use in conjunction with Revision tag with value of 2 to indicate and trigger new functionality.</p> <p>Value must be numeric. Units are inches. Required when ExpressMailIntlRequest/Size is LARGE.</p> <p>For example: <Height>11</Height></p>	decimal	minExclusive=0.0 totalDigits=10

Tag Name	Occurs	Description	Type	Validation
ExpressMailIntlRequest / Girth	optional	Use in conjunction with Revision tag with value of 2 to indicate and trigger new functionality. Value must be numeric. Units are inches. Required when ExpressMailIntlRequest/Size is LARGE, and ExpressMailIntlRequest/Container is NONRECTANGULAR. For example: <Girth>11</Girth>	decimal	minExclusive=0.0 totalDigits=10
ExpressMailIntlCertifyRequest	required once	API=ExpressMailIntlCertify "Certify" signature is for testing and demonstration - does not produce a mailable label	(alias)	

2.1.4 Request Example

```
<ExpressMailIntlCertifyRequest USERID="XXXXXX" PASSWORD="XXXXXX">
  <Option />
  <Revision>2</Revision>
  <ImageParameters />
  <FromFirstName>John</FromFirstName>
  <FromMiddleInitial>L</FromMiddleInitial>
  <FromLastName>Doe</FromLastName>
  <FromFirm />
  <FromAddress1>Apt 204</FromAddress1>
  <FromAddress2>2711 Ordway St NW</FromAddress2>
  <FromCity>Washington</FromCity>
  <FromState>DC</FromState>
  <FromZip5>20008</FromZip5>
  <FromZip4>5036</FromZip4>
  <FromPhone>3015551212</FromPhone>
  <ToName>Ms Joyce Browning</ToName>
  <ToFirm></ToFirm>
  <ToAddress1>5th floor</ToAddress1>
  <ToAddress2>2045 Royal Road</ToAddress2>
  <ToAddress3></ToAddress3>
  <ToCity>St Paul</ToCity>
  <ToProvince></ToProvince>
  <ToCountry>France</ToCountry>
```

```
<ToPostalCode>06570</ToPostalCode>
<ToPOBoxFlag>N</ToPOBoxFlag>
<ToPhone>4345551212</ToPhone>
<ToFax>4345559999</ToFax>
<ToEmail>b@aol.com</ToEmail>
<NonDeliveryOption>Return</NonDeliveryOption>
<Container>NONRECTANGULAR</Container>
<ShippingContents>
  <ItemDetail>
    <Description>Description 1</Description>
    <Quantity>1</Quantity>
    <Value>1.11</Value>
    <NetPounds>1</NetPounds>
    <NetOunces>1</NetOunces>
    <HSTariffNumber>123456</HSTariffNumber>
    <CountryOfOrigin>Brazil</CountryOfOrigin>
  </ItemDetail>
  <ItemDetail>
    <Description>Description 1</Description>
    <Quantity>1</Quantity>
    <Value>1.11</Value>
    <NetPounds>1</NetPounds>
    <NetOunces>1</NetOunces>
    <HSTariffNumber>123456</HSTariffNumber>
    <CountryOfOrigin>Brazil</CountryOfOrigin>
  </ItemDetail>
</ShippingContents>
```

```
<ItemDetail>
  <Description>Description 1</Description>
  <Quantity>1</Quantity>
  <Value>1.11</Value>
  <NetPounds>1</NetPounds>
  <NetOunces>1</NetOunces>
  <HSTariffNumber>123456</HSTariffNumber>
  <CountryOfOrigin>Brazil</CountryOfOrigin>
</ItemDetail>
<ItemDetail>
  <Description>Description 1</Description>
  <Quantity>1</Quantity>
  <Value>1.11</Value>
  <NetPounds>1</NetPounds>
  <NetOunces>1</NetOunces>
  <HSTariffNumber>123456</HSTariffNumber>
  <CountryOfOrigin>Brazil</CountryOfOrigin>
</ItemDetail>
<ItemDetail>
  <Description>Description 1</Description>
  <Quantity>1</Quantity>
  <Value>1.11</Value>
  <NetPounds>1</NetPounds>
  <NetOunces>1</NetOunces>
  <HSTariffNumber>123456</HSTariffNumber>
  <CountryOfOrigin>Brazil</CountryOfOrigin>
```

```
</ItemDetail>
</ShippingContents>
  <GrossPounds>17</GrossPounds>
  <GrossOunces>2</GrossOunces>
  <ContentType>Documents</ContentType>
  <Agreement>Y</Agreement>
  <Comments>ExpressMailIntlCertify Comments</Comments>
  <ImageType>TIF</ImageType>
  <ImageLayout>ALLINONEFILE</ImageLayout>
  <POZipCode>20770</POZipCode>
  <LabelDate />
  <HoldForManifest>N</HoldForManifest>
  <Size>LARGE</Size>
  <Length>20.5</Length>
  <Width>7</Width>
  <Height>15</Height>
  <Girth>40</Girth>
</ExpressMailIntlCertifyRequest>
```

2.2 Express Mail International Response

2.2.1 Response Diagram

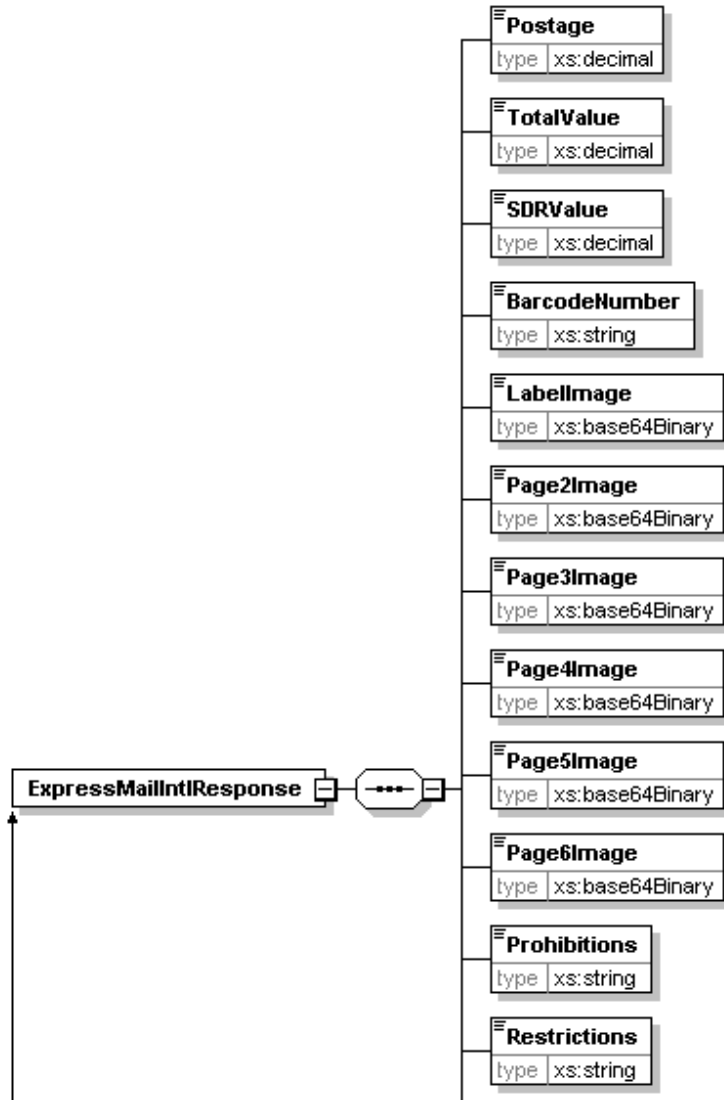

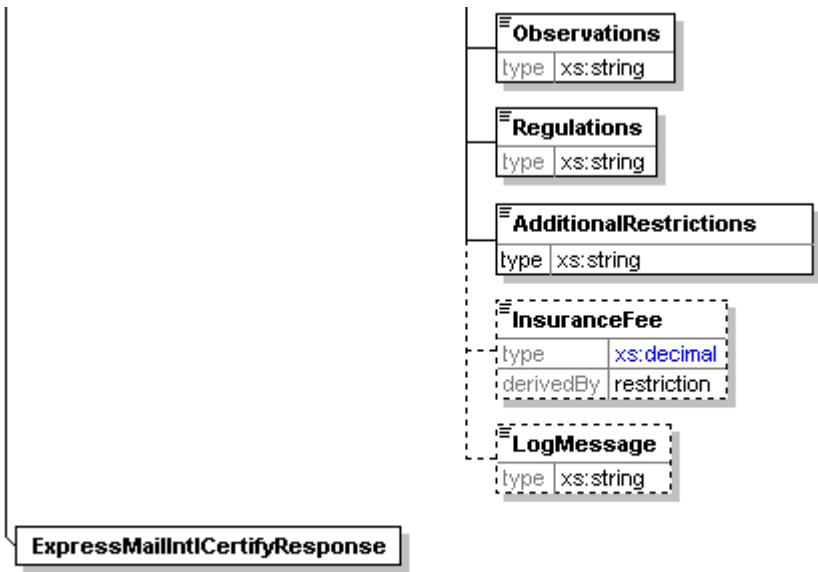

2.2.2 Response Parameters

Tag Name	Occurs	Description	Type	Validation
ExpressMailIntlResponse	required once		(group)	
ExpressMailIntlResponse / Postage	required once	Postage amount	xs:decimal	
ExpressMailIntlResponse / TotalValue	required once	Value of all items being shipped	xs:decimal	
ExpressMailIntlResponse / SDRValue	required once	Special Drawing Right calculated on Total Value	xs:decimal	
ExpressMailIntlResponse / BarcodeNumber	required once	Mail service related barcode, may be empty	xs:string	
ExpressMailIntlResponse / LabelImage	required once	Encoded images of label (may be empty depending upon layout option selected)	xs:string	
ExpressMailIntlResponse / Page2Image	required once	Encoded images of label (may be empty depending upon layout option selected)	xs:string	
ExpressMailIntlResponse / Page3Image	required once	Encoded images of label (may be empty depending upon layout option selected)	xs:string	
ExpressMailIntlResponse / Page4Image	required once	Encoded images of label (may be empty depending upon layout option selected)	xs:string	
ExpressMailIntlResponse / Page5Image	required once	Encoded images of label (may be empty depending upon layout option selected)	xs:string	
ExpressMailIntlResponse / Page6Image	required once	Encoded images of label (may be empty depending upon layout option selected)	xs:string	
ExpressMailIntlResponse / Prohibitions	required once	List of items prohibited from mailing based on country of destination	xs:string	
ExpressMailIntlResponse / Restrictions	required once	Restrictions on items being shipped based on country of destination	xs:string	
ExpressMailIntlResponse / Observations	required once	Additional mailing information based on country of destination	xs:string	

Tag Name	Occurs	Description	Type	Validation
ExpressMailIntlResponse / Regulations	required once	Additional regulations for shipping to destination country	xs:string	
ExpressMailIntlResponse / AdditionalRestrictions	required once	Additional restrictions on items being shipped to destination country	xs:string	
ExpressMailIntlResponse / Notes	required once	Express Mail International Notes	xs:string	
ExpressMailIntlResponse / InsuranceFee	optional		decimal	minExclusive=0.0 maxInclusive=5000
ExpressMailIntlResponse / LogMessage	optional	A text message for integrators of this API. It may contain additional information about this particular request/ response, or general information about the API or Web Tools. In typical implementations, whenever this tag is encountered, the message is written to the console log file for later analysis.	string	
ExpressMailIntlCertifyResponse	required once		(alias)	

2.2.3 Tagged Label Diagram

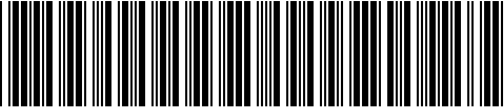
		Customs Declaration Dispatch Note CP 72  <BarcodeNumber>				U.S. POSTAGE REQUIRED		
From	<FromFirstName><FromMiddleInitial><FromLastName> <FromFirm> <FromAddress1> <FromAddress2> <FromUrbanization> <FromCity><FromState><FromZip5><FromZip4> US	License Number: <LicenseNumber>	Nondelivery Instructions: <NonDeliveryOption> <AltReturnAddress1> <AltReturnAddress2> <AltReturnAddress3> <AltReturnAddress4> <AltReturnAddress5> <AltReturnAddress6> <AltReturnCountry>					
		Certificate Number: <CertificateNumber>						
	Invoice Number: <InvoiceNumber>							
To	<ToName> <ToFirm> <ToAddress1> <ToAddress2> <ToAddress3> <ToPostalCode><ToCity><ToProvince> <ToCountry>	Importer's Telephone/Fax/Email: Phone: <ToPhone> Fax: <ToFax> Email: <ToEmail>			Scheduled Delivery Date: _____			
		Comments (e.g. goods subject to quarantine, sanitary/phytosanitary inspection or other restrictions): <Comments>						
Detailed description of contents		Qty	Weight lb oz	Value (US \$)	HS Tariff Number	Country of Origin	Insured Amount (US \$): <InsuredAmount>	
<Description>		<Quantity>	<NetPounds> ----- <NetOunces>	<Value>	<HSTariffNumber>	<CountryofOrigin>	SDR Value: <Postage>	
Contents: <input type="checkbox"/> Gift <input type="checkbox"/> Commercial Sample <input type="checkbox"/> Merchandise <ContentType> <input type="checkbox"/> Documents <input type="checkbox"/> Returned Goods <input type="checkbox"/> Other Explanation: <ContentTypeOther>		Total: Wt <GrossPounds>	Total Value	Postage and Fees			Mailing Office Date Stamp	
Sender's Customs Reference: (if known) <FromCustomsReference>		Importer's Customs Reference: (Fiscal or VAT number of the addressee, if known) <ToCustomsReference>		EEL / PFC: <EELPFC>				
I certify that the particulars given in this customs declaration are correct. This item does not contain any dangerous article, or articles prohibited by legislation or by postal or customs regulations. I have met all applicable export filing requirements under the Foreign Trade Regulations.				POSTAL USE ONLY				
Sender's Signature: <FromFirstName><FromMiddleInitial><FromLastName>		Date: 07/01/2010		Date In:	Time In: <input type="checkbox"/> AM <input type="checkbox"/> PM	Employee Initials:		

PS Form 2976-A-EMI

Do not duplicate this form without USPS approval.

The item/parcel may be opened officially.

1 - Customs Declaration

Fold or cut along line

2.2.4 Response Example

```
<?xml version="1.0" ?>
<ExpressMailIntlCertifyResponse>
  <Postage>110.00</Postage>
  <TotalValue>5.55</TotalValue>
  <SDRValue>3.65</SDRValue>
  <BarcodeNumber>ECXXXXXXXXUS</BarcodeNumber>
  <LabellImage>
    SUkqAAgAAAASAP4ABAABAAAAAAAAAAAAABBAABAAAAArgYAAAEBBAABAAAAAnQgAAAIBA...
  <!--Data Truncated -->
</LabellImage>
  <Page2Image />
  <Page3Image />
  <Page4Image />
  <Page5Image />
  <Page6Image />
  <Prohibitions>Arms, ammunition. Cigarette lighters using butane <!--37678 suppressed--></Prohibitions>
  <Restrictions>Bees, honey, and beeswax must be accompanied <!--12975 suppressed--></Restrictions>
  <Observations>1. An air parcel post item may be addressed to a <!--897 suppressed--></Observations>
  <Regulations>Country Code:FR Reciprocal Service Name: There <!--961 suppressed--> </Regulations>
  <AdditionalRestrictions/>
</ExpressMailIntlCertifyResponse>
```

3 Priority Mail International API

3.1 Priority Mail International Request

The table below presents the XML input tags for generating Live requests and the restrictions on the values allowed. An error message will be returned if an incorrect value is entered. Also, be aware of the maximum character amounts allowed for some tags. If the user enters more than those amounts, an error will not be generated. **The Web Tool will simply pass in the characters up to the maximum amount allowed and disregard the rest.** This is important since the resulting value could prevent a correct response.

When building the XML request, pay particular attention to the **order and case** for tags. An error message will be returned if an incorrect value is entered. Remember that all data and attribute values in this document are for illustration purposes and are to be replaced by your actual values. For instance, a line of sample code may be:

<ZipDestination>12345</ZipDestination>

In this instance, you will replace “12345” with the destination ZIP Code for the domestic-bound package.

3.1.1 API Signature

<i>Scheme</i>	<i>Host</i>	<i>Path</i>	<i>API</i>	<i>XML</i>
https://	secure.shippingapis.com	/ShippingAPI.dll	?API=PriorityMailIntl	&XML=(see below)
https://	secure.shippingapis.com	/ShippingAPI.dll	?API=PriorityMailIntlCertify	&XML=(see below)

3.1.2 Request Diagram

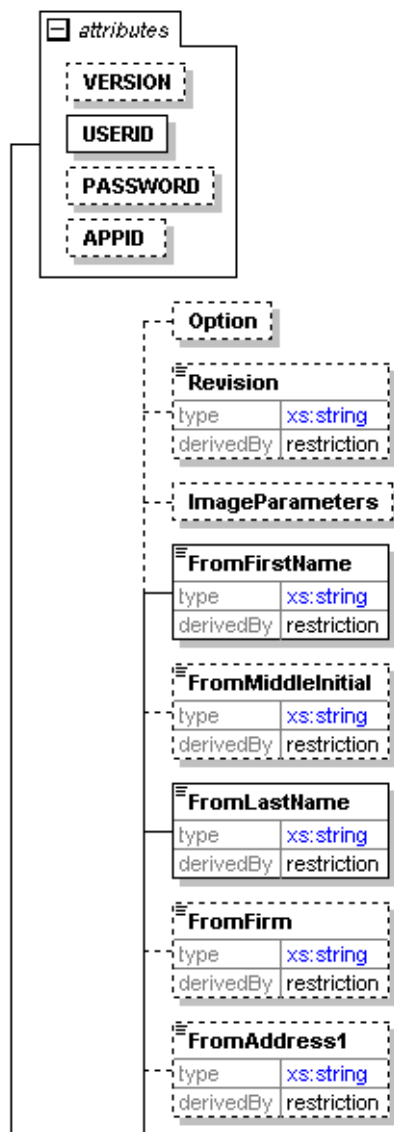

PriorityMailIntlRequest

FromAddress2
type [xs:string](#)
derivedBy restriction

FromUrbanization
type [xs:string](#)
derivedBy restriction

FromCity
type [xs:string](#)
derivedBy restriction

FromState
type [xs:string](#)
derivedBy restriction

FromZip5
type [xs:string](#)
derivedBy restriction

FromZip4
type [xs:string](#)
derivedBy restriction

FromPhone
type [xs:string](#)
derivedBy restriction

FromCustomsReference
type [xs:string](#)
derivedBy restriction

ToName
type [xs:string](#)
derivedBy restriction

ToFirm
type [xs:string](#)
derivedBy restriction

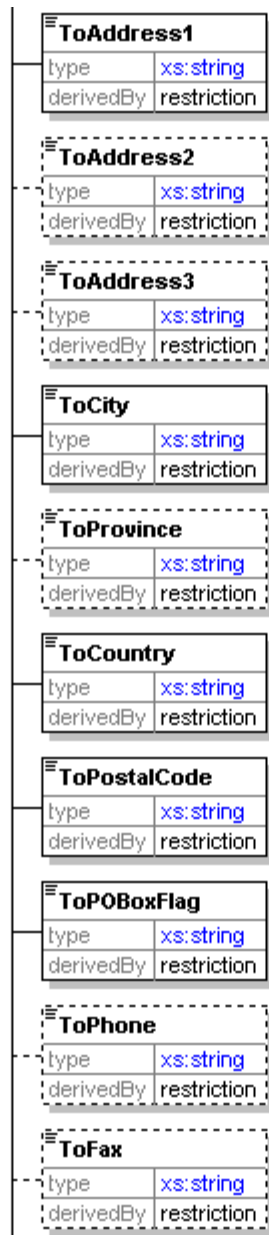

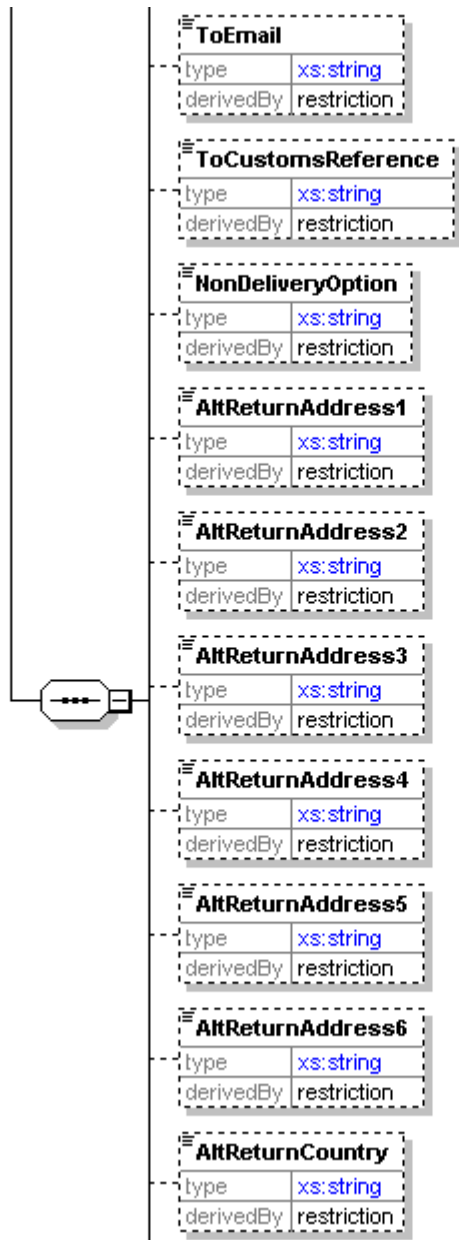

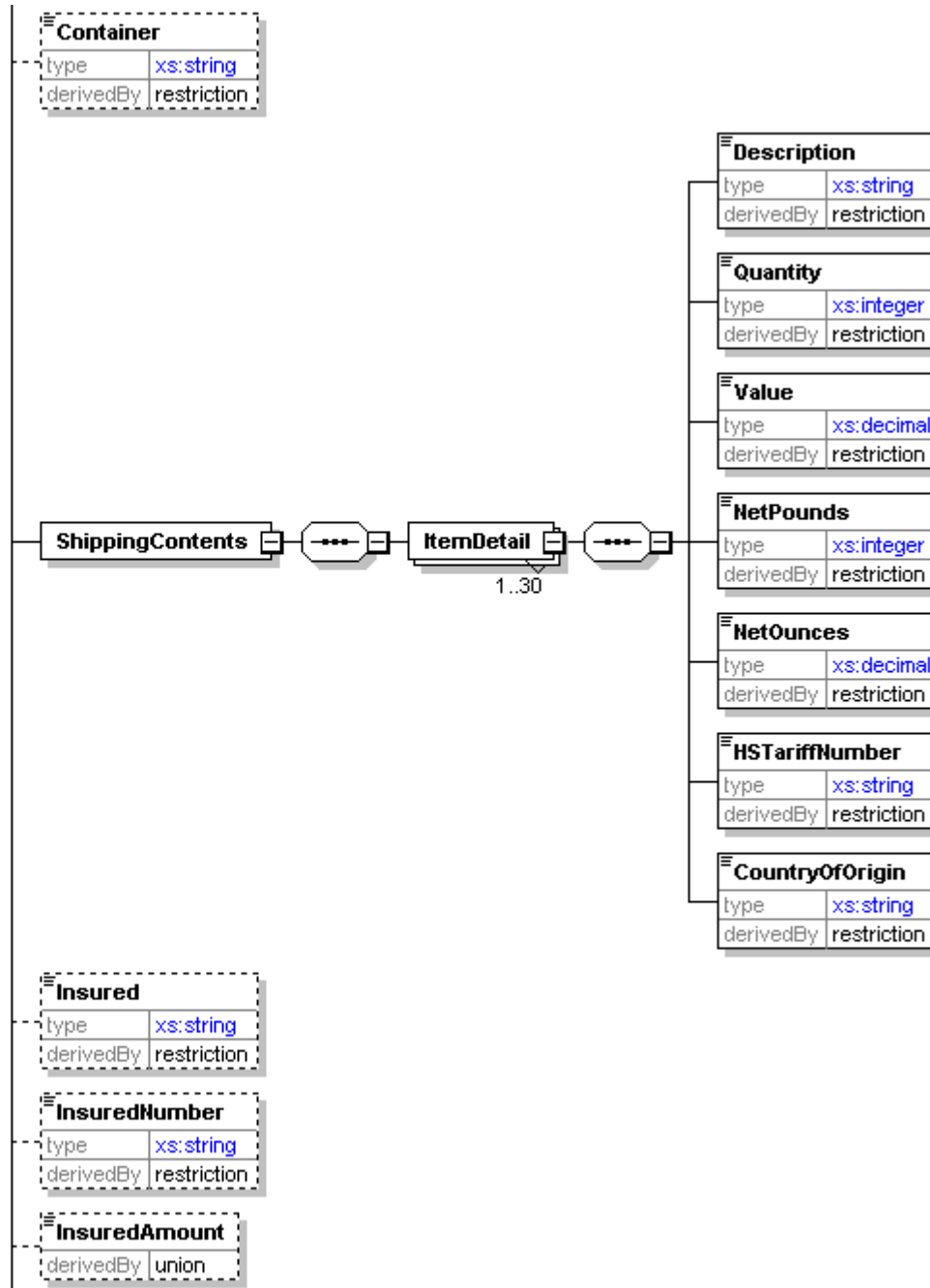

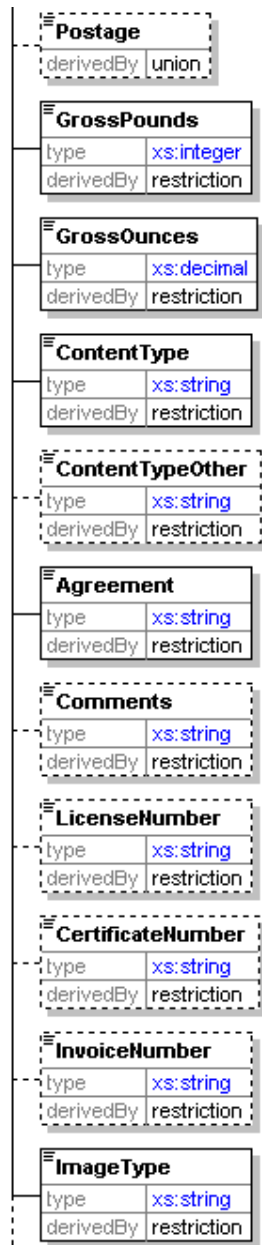

ImageLayout	
type	xs:string
derivedBy	restriction

CustomerRefNo	
type	xs:string
derivedBy	restriction

POZipCode	
type	xs:string
derivedBy	restriction

LabelDate	
type	xs:string
derivedBy	restriction

HoldForManifest	
type	xs:string
derivedBy	restriction

EELPFC	
type	xs:string
derivedBy	restriction

CommercialPrice	
type	xs:boolean
derivedBy	restriction

Size	
type	xs:string
derivedBy	restriction

Length	
type	xs:decimal
derivedBy	restriction

Width	
type	xs:decimal
derivedBy	restriction

PriorityMailIntCertifyRequest

Height	
type	xs:decimal
derivedBy	restriction

Girth	
type	xs:decimal
derivedBy	restriction

3.1.3 Request Parameters

Tag Name	Occurs	Description	Type	Validation
PriorityMailIntlRequest	required once	Produces a Priority Mail International label with customs declaraction	(group)	
PriorityMailIntlRequest / @USERID	required	This attribute specifies your Web Tools ID. See the Developer's Guide for information on obtaining your USERID.	NMTOKEN	
PriorityMailIntlRequest / @PASSWORD	optional	For backward compatibility; not validated.	NMTOKEN	
PriorityMailIntlRequest / Option	optional	For future use.	empty	
PriorityMailIntlRequest / Revision	required	Use of value 2 required as of January 2011. For example: <Revision>2</Revision>	string	
PriorityMailIntlRequest / ImageParameters	optional	For future use.	empty	
PriorityMailIntlRequest / FromFirstName	required once	First and Last Name must be sent. Maximum Length: 32 characters total for First, Middle, and Last Names with space after first and middle name. For example: <FromFirstName>John</FromFirstName>	string	maxLength=30 minLength=1 Restriction enforced via truncation
PriorityMailIntlRequest / FromMiddleInitial	optional	First and Last Name must be sent. Maximum Length: 32 characters total for First, Middle, and Last Names with space after first and middle name. For example: <FromMiddleInitial>L</FromMiddleInitial>	string	maxLength=1 Restriction enforced via truncation
PriorityMailIntlRequest / FromLastName	required once	First and Last Name must be sent. Maximum Length: 32 characters total for First, Middle, and Last Names with space after first and middle name. For example: <FromLastName>Doe</FromLastName>	string	maxLength=30 minLength=1 Restriction enforced via truncation

Tag Name	Occurs	Description	Type	Validation
PriorityMailIntlRequest / FromFirm	optional	Firm name; may be left blank. For example: <FromFirm></FromFirm>	string	maxLength=32 Restriction enforced via truncation
PriorityMailIntlRequest / FromAddress1	optional	Use this tag for a suite or apartment number only. Either Address1 or Address2 is required. For example: <FromAddress1/>	string	maxLength=32 Restriction enforced via truncation
PriorityMailIntlRequest / FromAddress2	required once	Use this tag for the primary address line. For example: <FromAddress2>10 Elm Street</FromAddress2>	string	maxLength=32 minLength=1 whiteSpace=collapse Restriction enforced via truncation
PriorityMailIntlRequest / FromUrbanization	optional	Use this tag for Puerto Rico only. ZIP Code prefixes 006 to 009, if area is so designated. For example: <FromUrbanization>URB Caparra Ter</FromUrbanization>	string	maxLength=32
PriorityMailIntlRequest / FromCity	required once	For example: <FromCity>Anytown</FromCity>	string	maxLength=16 minLength=1
PriorityMailIntlRequest / FromState	required once	Use 2-letter USPS abbreviation. For example: <FromState>ST</FromState>	string	length=2
PriorityMailIntlRequest / FromZip5	required once	Input tag exactly as presented, not all caps. 5 digits required. For example: <FromZip5>01234</FromZip5>	string	whiteSpace=collapse length=5 pattern=\d{5}
PriorityMailIntlRequest / FromZip4	optional	Input tag exactly as presented, not all caps. If value is entered, 4 digits required. This is the ZIP+4 extension. For example: <FromZip4>5678</FromZip4>	string	whiteSpace=collapse length=4 pattern=\d{4}
PriorityMailIntlRequest / FromPhone	required once	10 digits required (including area code), with no punctuation. Use format: 2125551234 For example: <FromPhone>5555555555</FromPhone>	string	whiteSpace=collapse length=10 pattern=\d{10}

Tag Name	Occurs	Description	Type	Validation
PriorityMailIntlRequest / FromCustomsReference	optional	Enter a value for the "Sender's Customs Reference" that will appear on the label. The text entered is any reference number that the sender wishes to use. For example: <FromCustomsReference></FromCustomsReference> Note: ignored when <Container> specified is a flat rate envelope or small flat rate box (SMFLATRATEBOX, DXDBOX, LGVIDEOBOX) variation.	string	maxLength=30
PriorityMailIntlRequest / ToName	required once	Enter a value for the recipient's name. For example: <ToName>Ms. C. P. Apple</ToName>	string	maxLength=36
PriorityMailIntlRequest / ToFirm	required once	Enter a value for the recipient's firm. For example: <ToFirm></ToFirm>	string	maxLength=36
PriorityMailIntlRequest / ToAddress1	required once	Three address lines are provided, but only 1 is required. Use as many as needed for complete address. For example: <ToAddress1> Apartado 3068</ToAddress1>	string	maxLength=36 minLength=1
PriorityMailIntlRequest / ToAddress2	optional	Three address lines are provided, but only 1 is required. Use as many as needed for complete address. For example: <ToAddress2></ToAddress2>	string	maxLength=36
PriorityMailIntlRequest / ToAddress3	optional	Three address lines are provided, but only 1 is required. Use as many as needed for complete address. For example: <ToAddress3></ToAddress3>	string	maxLength=36
PriorityMailIntlRequest / ToCity	required once	Recipient's city. For example: <ToCity>PUERTO VALLARTA</ToCity>	string	maxLength=18 minLength=1
PriorityMailIntlRequest / ToProvince	optional	Enter the province for the recipient. For example: <ToProvince>JALISCO</ToProvince>	string	maxLength=9

Tag Name	Occurs	Description	Type	Validation
PriorityMailIntlRequest / ToCountry	required once	The country name entered must match an entry from the USPS-approved International Index of Countries and Localities. (http://pe.usps.gov/text/lmm/lmmctry.htm - click on the link for "International Country Listings.") Using a country name not on the list will result in a request failure. For example: <ToCountry>MEXICO</ToCountry>	string	minLength=1
PriorityMailIntlRequest / ToPostalCode	required once	Enter the postal code for the recipient. For example: <ToPostalCode>46807</ToPostalCode>	string	maxLength=9
PriorityMailIntlRequest / ToPOBoxFlag	required once	Indicates whether or not the To Address is a Post Office Box. For example: <ToPOBoxFlag>N</ToPOBoxFlag>	string	enumeration=Y enumeration=N
PriorityMailIntlRequest / ToPhone	optional	No format checking is done on international phone numbers. Required when <ToPOBoxFlag>Y</ToPOBoxFlag> For example: <ToPhone>011 52 (322) 222-0069</ToPhone>	string	maxLength=30 Restriction enforced via truncation
PriorityMailIntlRequest / ToFax	optional	No format checking is done on international fax numbers. For example: <ToFax>011 52 (322) 222-0074</ToFax>	string	maxLength=30 Restriction enforced via truncation
PriorityMailIntlRequest / ToEmail	optional	Complete valid e-mail address is required if tag is used. For example: <ToEmail>cpapple@email.com</ToEmail>	string	maxLength=30 whiteSpace=collapse pattern=([\w\-\.\.]+)(([w-]+\.)+)[a-zA-Z]{2,4} Restriction enforced via truncation
PriorityMailIntlRequest / ToCustomsReference	optional	Enter a value for the "Recipient's Reference" that will appear on the label. The text entered is any reference number that the recipient wishes to use. For example: <ToReference>Order #23432</ToReference>	string	maxLength=28 Restriction enforced via truncation

Tag Name	Occurs	Description	Type	Validation
PriorityMailIntlRequest / NonDeliveryOption	optional	<p>In case package is undeliverable, enter one of the following: "RETURN" for package to be returned to <FromAddress> above. "REDIRECT" to return package to address specified below in <AltReturn...> tags. "ABANDON" to dispose of undeliverable package.</p> <p>For example: <NonDeliveryOption>RETURN</NonDeliveryOption></p> <p>Note: ignored when <Container> specified is a flat rate envelope or small flat rate box (SMFLATRATEBOX, DXDBOX, LGVIDEOBOX) variation.</p>	string	<p>default=ABANDON enumeration=RETURN enumeration=REDIRECT enumeration=ABANDON</p>
PriorityMailIntlRequest / AltReturnAddress1	optional	<p>Valid only with the "REDIRECT" value with the <NonDeliveryOption> tag. Six address lines are provided but only one is required. Use as many as needed for complete address.</p> <p>For example: <AltReturnAddress1></AltReturnAddress1></p> <p>Note: ignored when <Container> specified is a flat rate envelope or small flat rate box (SMFLATRATEBOX, DXDBOX, LGVIDEOBOX) variation.</p>	string	<p>maxLength=30 Restriction enforced via truncation</p>
PriorityMailIntlRequest / AltReturnAddress2	optional	<p>Valid only with the "REDIRECT" value with the <NonDeliveryOption> tag. Six address lines are provided but only one is required. Use as many as needed for complete address.</p> <p>For example: <AltReturnAddress2></AltReturnAddress2></p> <p>Note: ignored when <Container> specified is a flat rate envelope or small flat rate box (SMFLATRATEBOX, DXDBOX, LGVIDEOBOX) variation.</p>	string	<p>maxLength=30 Restriction enforced via truncation</p>

Tag Name	Occurs	Description	Type	Validation
PriorityMailIntlRequest / AltReturnAddress3	optional	<p>Valid only with the "REDIRECT" value with the <NonDeliveryOption> tag. Six address lines are provided but only one is required. Use as many as needed for complete address.</p> <p>For example: <AltReturnAddress3></AltReturnAddress3></p> <p>Note: ignored when <Container> specified is a flat rate envelope or small flat rate box (SMFLATRATEBOX, DXDBOX, LGVIDEOBOX) variation.</p>	string	maxLength=30 Restriction enforced via truncation
PriorityMailIntlRequest / AltReturnAddress4	optional	<p>Valid only with the "REDIRECT" value with the <NonDeliveryOption> tag. Six address lines are provided but only one is required. Use as many as needed for complete address.</p> <p>For example: <AltReturnAddress4></AltReturnAddress4></p> <p>Note: ignored when <Container> specified is a flat rate envelope or small flat rate box (SMFLATRATEBOX, DXDBOX, LGVIDEOBOX) variation.</p>	string	maxLength=30 Restriction enforced via truncation
PriorityMailIntlRequest / AltReturnAddress5	optional	<p>Valid only with the "REDIRECT" value with the <NonDeliveryOption> tag. Six address lines are provided but only one is required. Use as many as needed for complete address.</p> <p>For example: <AltReturnAddress5></AltReturnAddress5></p> <p>Note: ignored when <Container> specified is a flat rate envelope or small flat rate box (SMFLATRATEBOX, DXDBOX, LGVIDEOBOX) variation.</p>	string	maxLength=30 Restriction enforced via truncation

Tag Name	Occurs	Description	Type	Validation
PriorityMailIntlRequest / AltReturnAddress6	optional	<p>Valid only with the "REDIRECT" value with the <NonDeliveryOption> tag. Six address lines are provided but only one is required. Use as many as needed for complete address.</p> <p>For example: <AltReturnAddress6></AltReturnAddress6></p> <p>Note: ignored when <Container> specified is a flat rate envelope or small flat rate box (SMFLATRATEBOX, DXDBOX, LGVIDEOBOX) variation.</p>	string	maxLength=30 Restriction enforced via truncation
PriorityMailIntlRequest / AltReturnCountry	optional	<p>Required when <NonDeliveryOption>REDIRECT</NonDeliveryOption> and required to be equal to <ToCountry></p> <p>For Example: <AltReturnCountry>MEXICO</AltReturnCountry></p> <p>Note: ignored when <Container> specified is a flat rate envelope or small flat rate box (SMFLATRATEBOX, DXDBOX, LGVIDEOBOX) variation.</p>	string	

Tag Name	Occurs	Description	Type	Validation
PriorityMailIntlRequest / Container	optional	<p>Use <Container>MDFLATRATEBOX</Container> or <Container>LGFLATRATEBOX</Container> or <Container>SMFLATRATEBOX</Container> or <Container>LGVIDEOBOX</Container> or <Container>DVDBOX</Container> for flat rate boxes,</p> <p><Container>FLATRATEENV</Container> or <Container>LEGALFLATRATEENV</Container> or <Container>PADDEDFLATRATEENV</Container> or <Container>WINDOWFLATRATEENV</Container> or <Container>SMFLATRATEENV</Container> or <Container>GIFTCARDFLATRATEENV</Container> for flat rate envelopes.</p> <p>Otherwise, use to specify special containers or container attributes that may affect postage.</p> <p>Note: RECTANGULAR or NONRECTANGULAR must be indicated when <Size>LARGE</Size>.</p> <p>For the flat rate envelope and small flat rate box variations, gross weight must be 4 pounds or less and total value must be at most \$400.</p>	string	<p>default=VARIABLE enumeration=VARIABLE enumeration=RECTANGULAR enumeration=NONRECTANGULAR enumeration=LGFLATRATEBOX enumeration=MDFLATRATEBOX enumeration=SMFLATRATEBOX enumeration=FLATRATEBOX enumeration=LGVIDEOBOX enumeration=DVDBOX enumeration=FLATRATEENV enumeration=LEGALFLATRATEENV enumeration=PADDEDFLATRATEENV enumeration=WINDOWFLATRATEENV enumeration=SMFLATRATEENV enumeration=GIFTCARDFLATRATEENV</p>
PriorityMailIntlRequest / ShippingContents	required once		(group)	
PriorityMailIntlRequest / ShippingContents / ItemDetail	required once repeating up to 30 times	When <Container> specified is a flat rate envelope or small flat rate box (SMFLATRATEBOX, DVDBOX, LGVIDEOBOX) variation, maxOccurs="5"; that is, a maximum of five <ItemDetail/> tags is permitted.	(group)	
PriorityMailIntlRequest / ShippingContents / ItemDetail / Description	required once	<p>Description of the item.</p> <p>For example: <Description>Policy guidelines document</Description></p>	string	<p>maxLength=56 minLength=1 whiteSpace=collapse</p>

Tag Name	Occurs	Description	Type	Validation
PriorityMailIntlRequest / ShippingContents / ItemDetail / Quantity	required once	Quantity of the item. Integer value required. For example: <Quantity>1</Quantity>	integer	whiteSpace=collapse minExclusive=0
PriorityMailIntlRequest / ShippingContents / ItemDetail / Value	required once	The data entered with this tag provides the value of the set of items. If the item is 2 boxes of 50 pens and the value of each box is \$10.00, "20.00" (2 boxes x \$10.00) should be entered. If the value of each pen is .25 then "25.00" (100 pens x .25) should be entered. For example: <Value>55.00</Value>	decimal	whiteSpace=collapse minExclusive=0
PriorityMailIntlRequest / ShippingContents / ItemDetail / NetPounds	required once	Provide the pounds component of the weight of the individual item listed with <Description>. For example: <NetPounds>1</NetPounds>	integer	default=0 whiteSpace=collapse
PriorityMailIntlRequest / ShippingContents / ItemDetail / NetOunces	required once	Provide the ounces component of the weight of the individual item listed with <Description>. For example: <NetOunces>5</NetOunces>	decimal	default=0.0 whiteSpace=collapse
PriorityMailIntlRequest / ShippingContents / ItemDetail / HSTariffNumber	required once	For commercial items only. If known, the HS tariff number (6-digit) must be based on the Harmonized Commodity Description and Coding System developed by the World Customs Organization. For example: <HSTariffNumber>490110</HSTariffNumber>	string	whiteSpace=collapse maxLength=6 pattern=\d{0,6}

Tag Name	Occurs	Description	Type	Validation
PriorityMailIntlRequest / ShippingContents / ItemDetail / CountryOfOrigin	required once	For commercial items only. Country of Origin means the country where the goods originated, e.g. were produced, manufactured, or assembled. It is recommended you supply this information and attach an invoice to the outside to accelerate customs clearance in processing the items. The country name entered must match an entry from the USPS-approved International Index of Countries and Localities or be "United States". (http://pe.usps.gov/text/lmm/lmmctry.htm - click on the link for "International Country Listings.") Using a country name not on the list will result in a request failure. For example: <CountryOfOrigin>United States</CountryOfOrigin>	string	
PriorityMailIntlRequest / Insured	optional	Restricted use: authorized users may indicate with a value of Y that the item is insured for purposes of obtaining a barcode number from the insured range. All other users must specify N or omit.	string	default=N enumeration=Y enumeration=N
PriorityMailIntlRequest / InsuredNumber	optional	For backward-compatibility; not validated.	string	
PriorityMailIntlRequest / InsuredAmount	optional	Use this tag for entering an insurance amount, if known. For example: <InsuredAmount>100.00</InsuredAmount> Note: ignored when <Container> specified is a flat rate envelope or small flat rate box (SMFLATRATEBOX, DXDBOX, LGVIDEOBOX) variation.	string decimal	length=0
PriorityMailIntlRequest / Postage	optional	Use this tag for entering a postage amount, if known. If the tag is present, but the value is blank, the postage will be automatically calculated. For example: <Postage></Postage>	string decimal	length=0

Tag Name	Occurs	Description	Type	Validation
PriorityMailIntlRequest / GrossPounds	required once	Gross pounds and ounces together represent the total package weight, including packing material. For example, a package weighing 3 lbs 8 ounces would have "3" entered here and "8" entered with the <GrossOunces> tag. The Web Tool will check for maximum shipping weight of 70 pounds. Allowable weight may change based on the service used to send package and the destination country. For example: <GrossPounds>4</GrossPounds>	integer	whiteSpace=collapse
PriorityMailIntlRequest / GrossOunces	required once	Enter the ounces component of the total package weight with this tag. For example: <GrossOunces>0</GrossOunces>	decimal	whiteSpace=collapse
PriorityMailIntlRequest / ContentType	required once	Specifies the content of the package or envelope. For example: <ContentType>DOCUMENTS</ContentType> Note: when <Container> specified is a flat rate envelope or small flat rate box (SMFLATRATEBOX, DXDBOX, LGVIDEOBOX) variation, RETURN is not a valid option.	string	enumeration=MERCHANDISE enumeration=SAMPLE enumeration=GIFT enumeration=DOCUMENTS enumeration=RETURN enumeration=OTHER
PriorityMailIntlRequest / ContentTypeOther	optional	Required when <ContentType>OTHER<ContentType>. Maximum length enforced via truncation	string	maxLength=15 whiteSpace=collapse
PriorityMailIntlRequest / Agreement	required once	Requires a value of Y to print <FromFirstName/> and <FromLastName/> in Signature Box along with Current Date (Central Time USA). Any other value returns an error.	string	enumeration=Y enumeration=N
PriorityMailIntlRequest / Comments	optional	Enter any comments. For example: <Comments></Comments> Note: ignored when <Container> specified is a flat rate envelope.	string	maxLength=76

Tag Name	Occurs	Description	Type	Validation
PriorityMailIntlRequest / LicenseNumber	optional	Enter license number, if known or if included in package. For example: <LicenseNumber>LIC-24356879</LicenseNumber> Note: ignored when <Container> specified is a flat rate envelope or small flat rate box (SMFLATRATEBOX, DXDBOX, LGVIDEOBOX) variation.	string	maxLength=24
PriorityMailIntlRequest / CertificateNumber	optional	Enter certificate number, if known or if included in package. For example: <CertificateNumber>CERT-97865342</CertificateNumber> Note: ignored when <Container> specified is a flat rate envelope or small flat rate box (SMFLATRATEBOX, DXDBOX, LGVIDEOBOX) variation.	string	maxLength=24
PriorityMailIntlRequest / InvoiceNumber	optional	Enter invoice number, if known or if included in package. For example: <InvoiceNumber>INV-040903</InvoiceNumber> Note: ignored when <Container> specified is a flat rate envelope or small flat rate box (SMFLATRATEBOX, DXDBOX, LGVIDEOBOX) variation.	string	maxLength=24
PriorityMailIntlRequest / ImageType	required once	For example: <ImageType>PDF</ImageType>	string	enumeration=PDF enumeration=TIF enumeration=NONE
PriorityMailIntlRequest / ImageLayout	optional	See section 2.2 Form Output Layout Control. For example: <ImageLayout>TRIMONEPERFILE</ImageLayout>	string	default=ONEPERFILE enumeration=ONEPERFILE enumeration=ALLINONEFILE enumeration=TRIMONEPERFILE enumeration=TRIMALLINONEFILE

Tag Name	Occurs	Description	Type	Validation
PriorityMailIntlRequest / CustomerRefNo	optional	Written to Postal Manifest Detail record. For example: <CustomerRefNo>Ref #369246</CustomerRefNo> Note: ignored when <Container> specified is a flat rate envelope or small flat rate box (SMFLATRATEBOX, DXDBOX, LGVIDEOBOX) variation.	string	maxLength=30
PriorityMailIntlRequest / POZipCode	optional	ZIP of Post Office where mailed if different from <FromZip5/>. Written to Postal Manifest Detail record. Must be valid ZIP Code. For example: <POZipCode>00962</POZipCode>	string	whiteSpace=collapse length=5 pattern=\d{5}
PriorityMailIntlRequest / LabelDate	optional	Date the mail will enter the mail stream. No more than 3 days in the future. Default is day of request. For example: <LabelDate>09/28/2010</LabelDate>	string	whiteSpace=collapse maxLength=10 pattern=\d{1,2}\d{1,2}\d\d(\d\d)?
PriorityMailIntlRequest / HoldForManifest	optional	Restricted use. Holds manifest record for possible inclusion in SCAN request.	string	enumeration=Y enumeration=N
PriorityMailIntlRequest / EELPFC	optional	Exemption and Exclusion Legend or PFC Code. Use in conjunction with Revision tag with value of 1 to indicate and trigger new functionality. Please refer to the International Mail Manual for further information - http://pe.usps.gov/text/imm/immc5_007.htm . To activate check boxes use "30.37a" or "30.37h". For example: <EELPFC>30.37a</EELPFC>	string	whiteSpace=collapse minLength=0 maxLength=35

Tag Name	Occurs	Description	Type	Validation
PriorityMailIntlRequest / CommercialPrice	optional	Indicates if commercial-base price should be returned. For commercial-base price eligibility, please reference the Domestic Mail Manual at http://pe.usps.com/ . For example: <CommercialPrice>False</CommercialPrice>	boolean	default=false
PriorityMailIntlRequest / Size	optional	Use in conjunction with Revision tag with value of 2 to indicate and trigger new functionality. Defined as follows: REGULAR: Package dimensions are 12" or less; LARGE: Any package dimension is larger than 12". For example: <Size>REGULAR</Size>	string	whiteSpace=collapse enumeration=LARGE enumeration=REGULAR
PriorityMailIntlRequest / Length	optional	Value must be numeric. Units are inches. Required when PriorityMailIntlRequest/Size is LARGE. For example: <Width>5.5</Width>	decimal	minExclusive=0.0 totalDigits=10
PriorityMailIntlRequest / Width	optional	Value must be numeric. Units are inches. Required when PriorityMailIntlRequest/Size is LARGE. For example: <Length>11</Length>	decimal	minExclusive=0.0 totalDigits=10
PriorityMailIntlRequest / Height	optional	Value must be numeric. Units are inches. Required when PriorityMailIntlRequest/Size is LARGE. For example: <Height>11</Height>	decimal	minExclusive=0.0 totalDigits=10
PriorityMailIntlRequest / Girth	optional	Value must be numeric. Units are inches. Required when PriorityMailIntlRequest/Size is LARGE, and PriorityMailIntlRequest/Container is NONRECTANGULAR. For example: <Girth>11</Girth>	decimal	minExclusive=0.0 totalDigits=10

Tag Name	Occurs	Description	Type	Validation
PriorityMailIntlCertifyRequest	required once	API=PriorityMailIntlCertify "Certify" signature is for testing and demonstration - does not produce a mailable label	(alias)	

3.1.4 Request Example

```
<PriorityMailIntlCertifyRequest USERID="xxx">  
  <Option/>  
  <Revision>2</Revision>  
  <ImageParameters/>  
  <FromFirstName>John</FromFirstName>  
  <FromMiddleInitial>L</FromMiddleInitial>  
  <FromLastName>Doe</FromLastName>  
  <FromFirm>USPS</FromFirm>  
  <FromAddress1>Suite 10000</FromAddress1>  
  <FromAddress2>475 Lenfant</FromAddress2>  
  <FromCity>Washington</FromCity>  
  <FromState>DC</FromState>  
  <FromZip5>20260</FromZip5>  
  <FromPhone>2025551212</FromPhone>  
  <ToName>Ms. Joyce Browning</ToName>  
  <ToFirm>XYZ Corp.</ToFirm>  
  <ToAddress1>5th Floor</ToAddress1>  
  <ToAddress2>Frankfurter Allee 1</ToAddress2>  
  <ToAddress3></ToAddress3>  
  <ToCity>Munich</ToCity>  
  <ToProvince></ToProvince>  
  <ToCountry>Germany</ToCountry>  
  <ToPostalCode>83497</ToPostalCode>
```

```
<ToPOBoxFlag>N</ToPOBoxFlag>
<ToPhone>5155551212</ToPhone>
<ToFax>8884865188</ToFax>
<ToEmail>b@aol.com</ToEmail>
<NonDeliveryOption>Return</NonDeliveryOption>
<Container>VARIABLE</Container>
<ShippingContents>
  <ItemDetail>
    <Description>Description 1</Description>
    <Quantity>1</Quantity>
    <Value>1.11</Value>
    <NetPounds>1</NetPounds>
    <NetOunces>1</NetOunces>
    <HSTariffNumber>123456</HSTariffNumber>
    <CountryOfOrigin>Brazil</CountryOfOrigin>
  </ItemDetail>
  <ItemDetail>
    <Description>Description 2</Description>
    <Quantity>2</Quantity>
    <Value>2.22</Value>
    <NetPounds>2</NetPounds>
    <NetOunces>2</NetOunces>
    <HSTariffNumber>234567</HSTariffNumber>
    <CountryOfOrigin>Canada</CountryOfOrigin>
  </ItemDetail>
</ShippingContents>
```

```
<Insured>N</Insured>  
<GrossPounds>3</GrossPounds>  
<GrossOunces>3</GrossOunces>  
<ContentType>Merchandise</ContentType>  
<Agreement>Y</Agreement>  
<Comments>PriorityMailIntl Comments</Comments>  
<ImageType>TIF</ImageType>  
<ImageLayout>ALLINONEFILE</ImageLayout>  
<POZipCode>20770</POZipCode>  
<LabelDate>4/23/2007</LabelDate>  
<HoldForManifest>N</HoldForManifest>  
<EELPFC>30.37a</EELPFC>  
<Size>LARGE</Size>  
<Length>10.5</Length>  
<Width>5.5</Width>  
<Height>5.5</Height>  
<Girth>35.5</Girth>  
</PriorityMailIntlCertifyRequest>
```

3.2 Priority Mail International Response

3.2.1 Response Diagram

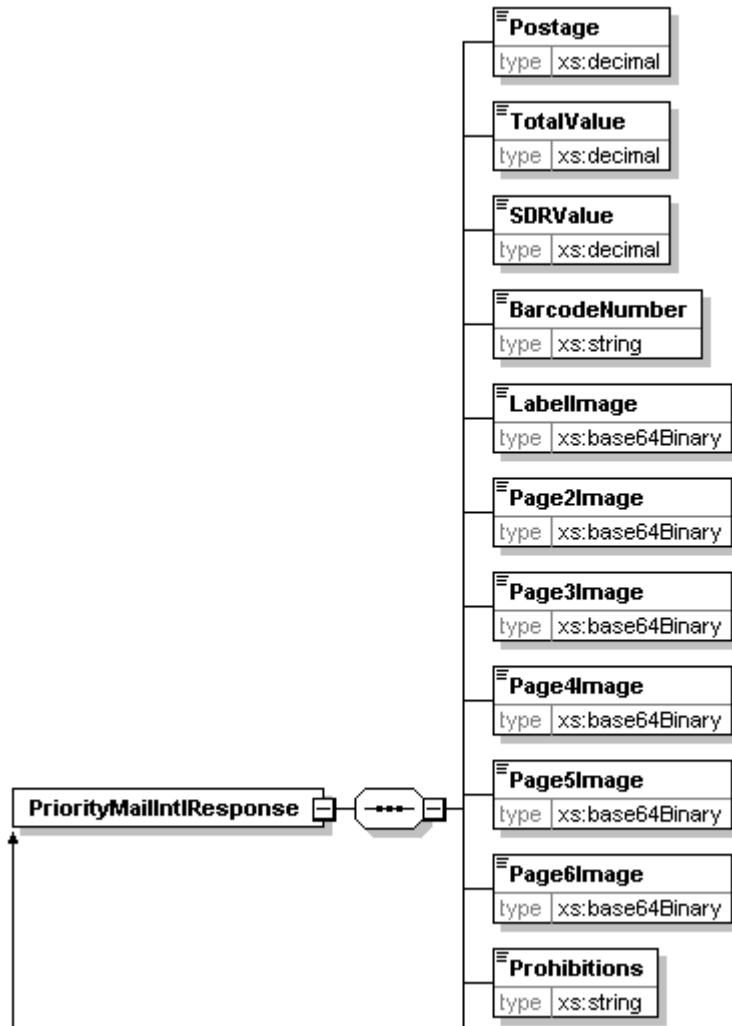

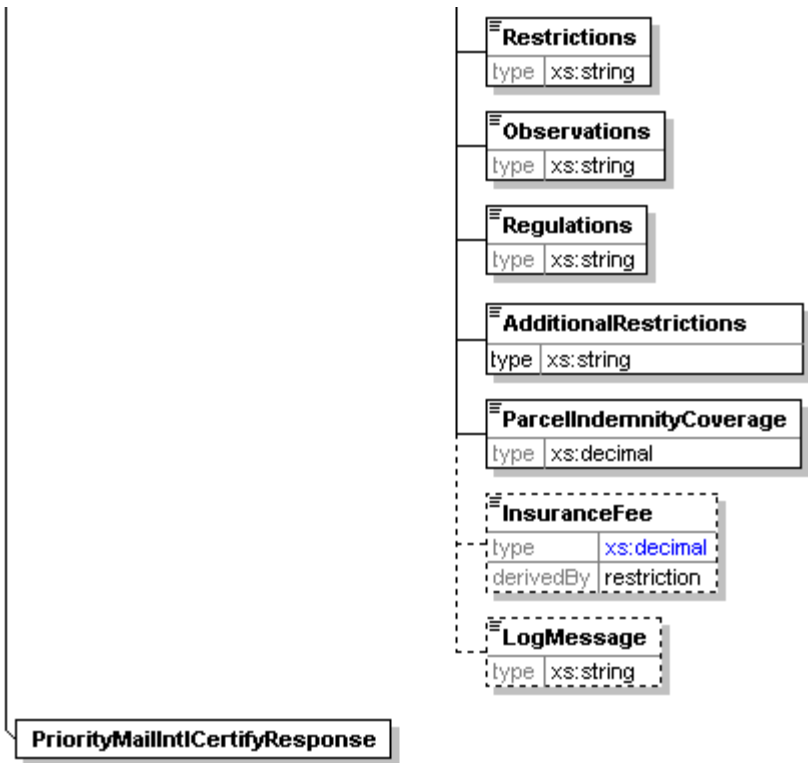

3.2.2 Response Parameters

Tag Name	Occurs	Description	Type	Validation
PriorityMailIntlResponse	required once		(group)	
PriorityMailIntlResponse / Postage	required once	Postage amount	decimal	
PriorityMailIntlResponse / TotalValue	required once	Value of all items being shipped	decimal	
PriorityMailIntlResponse / SDRValue	required once	Special Drawing Right calculated on Total Value	decimal	
PriorityMailIntlResponse / BarcodeNumber	required once	Mail service related barcode, may be empty	string	
PriorityMailIntlResponse / LabelImage	required once	Encoded images of label (may be empty depending upon layout option selected)	base64Binary	
PriorityMailIntlResponse / Page2Image	required once	Encoded images of label (may be empty depending upon layout option selected)	base64Binary	
PriorityMailIntlResponse / Page3Image	required once	Encoded images of label (may be empty depending upon layout option selected)	base64Binary	
PriorityMailIntlResponse / Page4Image	required once	Encoded images of label (may be empty depending upon layout option selected)	base64Binary	
PriorityMailIntlResponse / Page5Image	required once	Encoded images of label (may be empty depending upon layout option selected)	base64Binary	
PriorityMailIntlResponse / Page6Image	required once	Encoded images of label (may be empty depending upon layout option selected)	base64Binary	
PriorityMailIntlResponse / Prohibitions	required once	List of items prohibited from mailing based on country of destination	string	
PriorityMailIntlResponse / Restrictions	required once	Restrictions on items being shipped based on country of destination	string	
PriorityMailIntlResponse / Observations	required once	Additional mailing information based on country of destination	string	
PriorityMailIntlResponse / Regulations	required once	Additional regulations for shipping to destination country	string	

Tag Name	Occurs	Description	Type	Validation
PriorityMailIntlResponse / AdditionalRestrictions	required once	Additional restrictions on items being shipped to destination country	string	
PriorityMailIntlResponse / ParcelIndemnityCoverage	required once	Indemnity value	decimal	
PriorityMailIntlResponse / InsuranceFee	optional		decimal	minExclusive=0.0 maxInclusive=5000
PriorityMailIntlResponse / LogMessage	optional	A text message for integrators of this API. It may contain additional information about this particular request/response, or general information about the API or Web Tools. In typical implementations, whenever this tag is encountered, the message is written to the console log file for later analysis.	string	
PriorityMailIntlCertifyResponse	required once		(alias)	

3.2.3 Tagged Label Diagram

 PRIORITY MAIL UNITED STATES POSTAL SERVICE ®		Customs Declaration Dispatch Note CP 72  <BarcodeNumber>			U.S. POSTAGE REQUIRED				
From	<FromFirstName><FromMiddleInitial><FromLastName> <FromFirm> <FromAddress1> <FromAddress2> <FromUrbanization> <FromCity><FromState><FromZip5><FromZip4> US		License Number: <LicenseNumber>		Nondelivery Instructions: <NonDeliveryOption> <AltReturnAddress1> <AltReturnAddress2> <AltReturnAddress3> <AltReturnAddress4> <AltReturnAddress5> <AltReturnAddress6> <AltReturnCountry>				
			Certificate Number: <CertificateNumber>						
		Invoice Number: <InvoiceNumber>							
To	<ToName> <ToFirm> <ToAddress1> <ToAddress2> <ToAddress3> <ToPostalCode><ToCity><ToProvince> <ToCountry>		Importer's Telephone/Fax/Email: Phone: <ToPhone> Fax: <ToFax> Email: <ToEmail>		Insured: <InsuredAmount>				
			Comments (e.g. goods subject to quarantine, sanitary/phytosanitary inspection or other restrictions): <Comments>						
Detailed description of contents				Qty	Weight lb oz	Value (US \$)	HS Tariff Number	Country of Origin	Insured Amount (US \$): <InsuredAmount>
<Description>				<Quantity>	<NetPounds> ----- <NetOunces>	<Value>	<HSTariffNumber>	<CountryofOrigin>	SDR Value:
Contents: <input type="checkbox"/> Gift <input type="checkbox"/> Commercial Sample <input type="checkbox"/> Merchandise <ContentType> <input type="checkbox"/> Documents <input type="checkbox"/> Returned Goods <input type="checkbox"/> Other Explanation: <ContentTypeOther>				Total Wt <GrossPounds>	Total Value <GrossOunces>	Postage and Fees			Mailing Office Date Stamp
Sender's Customs Reference: (if known) <FromCustomsReference>		Importer's Customs Reference: (fiscal or VAT number of the addressee, if known) <ToCustomsReference>		EEL / PFC: <EELPFC>					
I certify that the particulars given in this customs declaration are correct. This item does not contain any dangerous article, or articles prohibited by legislation or by postal or customs regulations. I have met all applicable export filing requirements under the Foreign Trade Regulations.						POSTAL USE ONLY			
Sender's Signature: <FromFirstName><FromMiddleInitial><FromLastName>		Date: 07/01/2010		Date In:	Time In: <input type="checkbox"/> AM <input type="checkbox"/> PM	Employee Initials:			

PS Form 2976-A-PMI

Do not duplicate this form without USPS approval.

The item/parcel may be opened officially.

1 - Customs Declaration

Fold or cut along line

3.2.4 Response Example

```
<?xml version="1.0"?>
<PriorityMailIntlCertifyResponse>
  <Postage>37.15</Postage>
  <TotalValue>3.33</TotalValue>
  <SDRValue>2.19</SDRValue>
  <BarcodeNumber>CJXXXXXXXXXUS</BarcodeNumber>
  <LabelImage/>SUKqAAgAAAASAP4ABAABAAAAAAAAAAAAABBAABAAAAArgYAAAEBBAABAAAAAnQgAAAI
  <!--Data Truncated -->
</LabelImage>
<Page2Image/>
<Page3Image/>
<Page4Image/>
<Page5Image/>
<Page6Image/>
<Prohibitions>Absinthe. Articles bearing political or religious notations on the address si<!--513 suppressed--></Prohibitions>
<Restrictions>Importation of medicines requires special authorization by German authorities.</Restrictions>
<Observations>1. An air parcel post item may be addressed to a street address or to a pos<!--1457 suppressed--></Observations>
<Regulations>Country Code: DE Reciprocal Service Name: There is no reciprocal service. <!--715 suppressed--></Regulations>
<AdditionalRestrictions/>
<ParcelIndemnityCoverage>73.23</ParcelIndemnityCoverage>
</PriorityMailIntlCertifyResponse>
```

4 First Class Mail International API

4.1 First Class Mail International Request

The table below presents the XML input tags for generating Live requests and the restrictions on the values allowed. An error message will be returned if an incorrect value is entered. Also, be aware of the maximum character amounts allowed for some tags. If the user enters more than those amounts, an error will not be generated. **The Web Tool will simply pass in the characters up to the maximum amount allowed and disregard the rest.** This is important since the resulting value could prevent a correct response.

When building the XML request, pay particular attention to the **order and case** for tags. An error message will be returned if an incorrect value is entered. Remember that all data and attribute values in this document are for illustration purposes and are to be replaced by your actual values. For instance, a line of sample code may be:

`<ZipDestination>12345</ZipDestination>`

In this instance, you will replace “12345” with the destination ZIP Code for the domestic-bound package.

4.1.1 API Signature

<i>Scheme</i>	<i>Host</i>	<i>Path</i>	<i>API</i>	<i>XML</i>
https://	secure.shippingapis.com	/ShippingAPI.dll	?API=FirstClassMailIntl	&XML=(see below)
https://	secure.shippingapis.com	/ShippingAPI.dll	?API=FirstClassMailIntlCertify	&XML=(see below)

4.1.2 Request Diagram

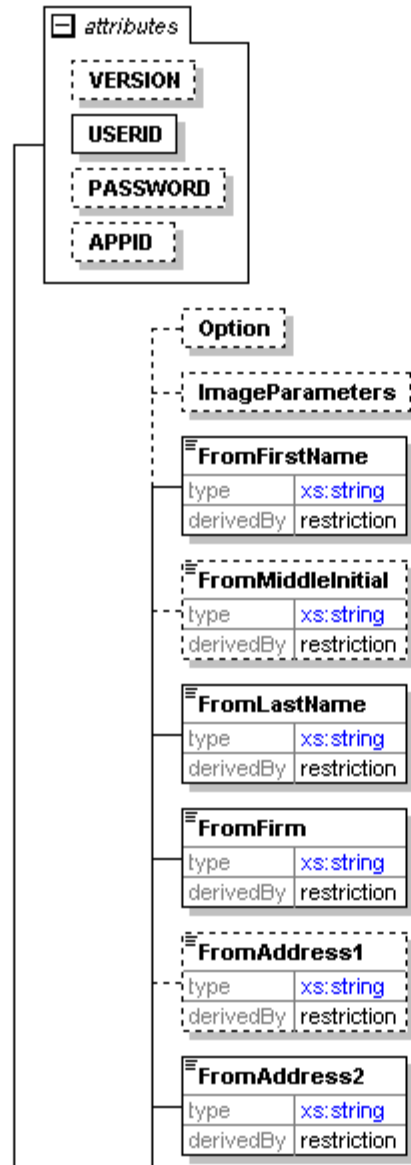

FirstClassMailIntlRequest

FromUrbanization	
type	xs:string
derivedBy	restriction

FromCity	
type	xs:string
derivedBy	restriction

FromState	
type	xs:string
derivedBy	restriction

FromZip5	
type	xs:string
derivedBy	restriction

FromZip4	
type	xs:string
derivedBy	restriction

FromPhone	
type	xs:string
derivedBy	restriction

ToName	
type	xs:string
derivedBy	restriction

ToFirm	
type	xs:string
derivedBy	restriction

ToAddress1	
type	xs:string
derivedBy	restriction

ToAddress2	
type	xs:string
derivedBy	restriction

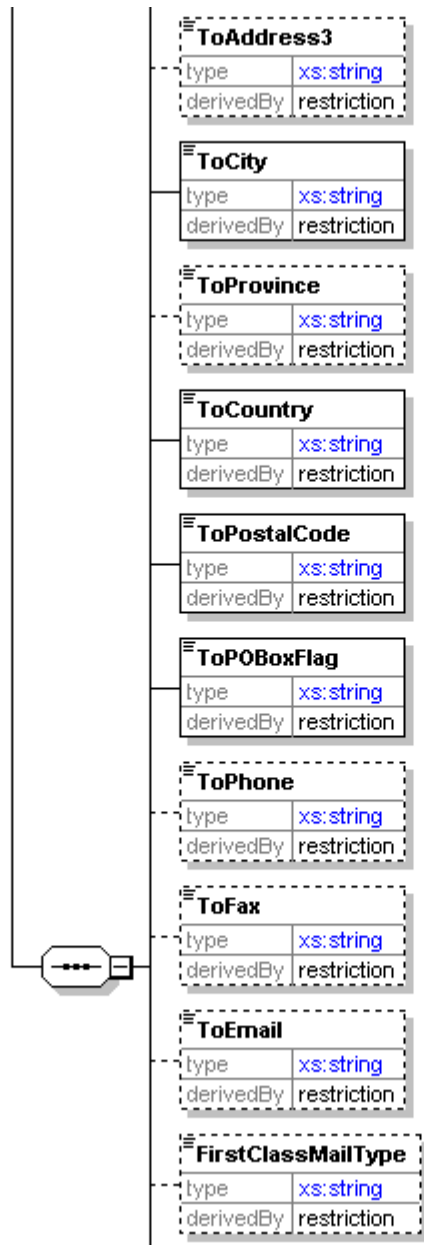

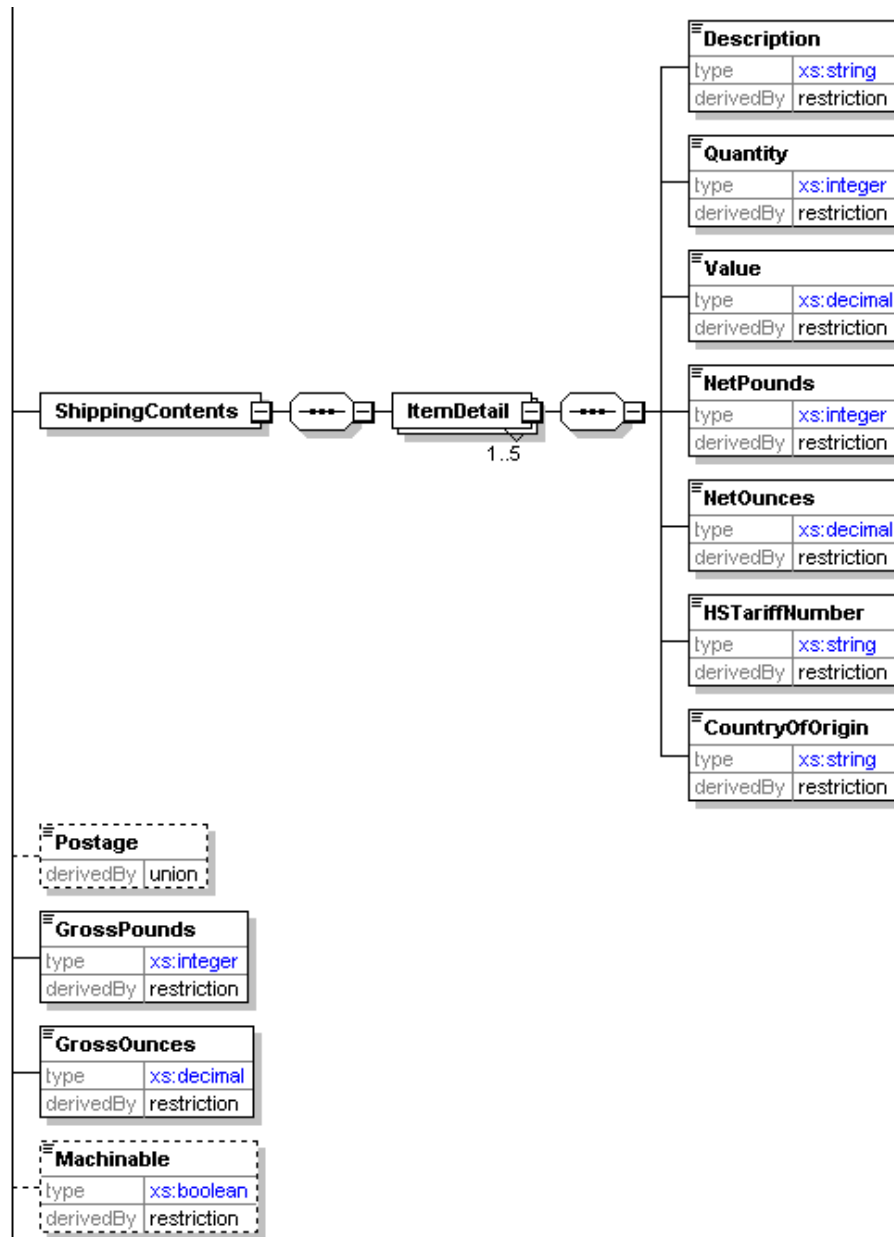

ContentType	
type	xs:string
derivedBy	restriction

ContentTypeOther	
type	xs:string
derivedBy	restriction

Agreement	
type	xs:string
derivedBy	restriction

Comments	
type	xs:string
derivedBy	restriction

LicenseNumber	
type	xs:string
derivedBy	restriction

CertificateNumber	
type	xs:string
derivedBy	restriction

InvoiceNumber	
type	xs:string
derivedBy	restriction

Image Type	
type	xs:string
derivedBy	restriction

ImageLayout	
type	xs:string
derivedBy	restriction

CustomerRefNo	
type	xs:string
derivedBy	restriction

LabelDate	
type	xs:string
derivedBy	restriction

FirstClassMailIntlCertifyRequest

HoldForManifest	
type	xs:string
derivedBy	restriction

EELPFC	
type	xs:string
derivedBy	restriction

Container	
type	xs:string
derivedBy	restriction

Size	
type	xs:string
derivedBy	restriction

Length	
type	xs:decimal
derivedBy	restriction

Width	
type	xs:decimal
derivedBy	restriction

Height	
type	xs:decimal
derivedBy	restriction

Girth	
type	xs:decimal
derivedBy	restriction

4.1.3 Request Parameters

Tag Name	Occurs	Description	Type	Validation
FirstClassMailIntlRequest	required once		(group)	
FirstClassMailIntlRequest / @USERID	required	This attribute specifies your Web Tools ID. See the Developer's Guide for information on obtaining your USERID.	NMTOKEN	
FirstClassMailIntlRequest / @PASSWORD	optional	For backward compatibility; not validated.	NMTOKEN	
FirstClassMailIntlRequest / Option	optional	For future use.	empty	
FirstClassMailIntlRequest / Revision	required	Use of value 2 required as of January 2011. For example: <Revision>2</Revision>	string	
FirstClassMailIntlRequest / ImageParameters	optional	For future use.	empty	
FirstClassMailIntlRequest / FromFirstName	required once	First and Last Name must be sent. Maximum Length: 32 characters total for First, Middle, and Last Names with space after first and middle name. For example: <FromFirstName>John</FromFirstName>	string	maxLength=30 minLength=1 whiteSpace=collapse
FirstClassMailIntlRequest / FromMiddleInitial	optional	First and Last Name must be sent. Maximum Length: 32 characters total for First, Middle, and Last Names with space after first and middle name. For example: <FromMiddleInitial>L</FromMiddleInitial>	string	maxLength=1 whiteSpace=collapse

Tag Name	Occurs	Description	Type	Validation
FirstClassMailIntlRequest / FromLastName	required once	First and Last Name must be sent. Maximum Length: 32 characters total for First, Middle, and Last Names with space after first and middle name. For example: <FromLastName>Doe</FromLastName>	string	maxLength=30 minLength=1 whiteSpace=collapse
FirstClassMailIntlRequest / FromFirm	required once	Firm name; may be left blank. For example: <FromFirm></FromFirm>	string	maxLength=32 whiteSpace=collapse
FirstClassMailIntlRequest / FromAddress1	optional	Use this tag for a suite or apartment number only. For example: <FromAddress1/>	string	maxLength=32 whiteSpace=collapse
FirstClassMailIntlRequest / FromAddress2	required once	Use this tag for the primary address line. For example: <FromAddress2>10 Elm Street</FromAddress2>	string	maxLength=32 minLength=1 whiteSpace=collapse
FirstClassMailIntlRequest / FromUrbanization	optional	Use this tag for Puerto Rico only. ZIP Code prefixes 006 to 009, if area is so designated. For example: <FromUrbanization>URB Caparra Ter</FromUrbanization>	string	maxLength=32 whiteSpace=collapse
FirstClassMailIntlRequest / FromCity	required once	Use this tag to specify originating city. For example: <FromCity>Anytown</FromCity>	string	maxLength=16 minLength=1 whiteSpace=collapse
FirstClassMailIntlRequest / FromState	required once	Use 2-letter USPS abbreviation. For example: <FromState>AK</FromState>	string	length=2 whiteSpace=collapse
FirstClassMailIntlRequest / FromZip5	required once	Five-digit valid ZIP code required. For example: <FromZip5>01234</FromZip5>	string	whiteSpace=collapse length=5 pattern=\d{5}

Tag Name	Occurs	Description	Type	Validation
FirstClassMailIntlRequest / FromZip4	optional	If value is entered, four digits are required. Must be a valid ZIP+4 extension. For example: <FromZip4>5678</FromZip4>	string	whiteSpace=collapse length=4 pattern=\d{4}
FirstClassMailIntlRequest / FromPhone	required once	10 digits required (including area code), with no punctuation. Use format: 2125551234 For example: <FromPhone>5555555555</FromPhone>	string	whiteSpace=collapse length=10 pattern=\d{10}
FirstClassMailIntlRequest / ToName	required once	Enter a value for the recipient's name; may be left blank if Firm name is provided. For example: <ToName>Ms. C. P. Apple</ToName>	string	maxLength=36 whiteSpace=collapse
FirstClassMailIntlRequest / ToFirm	required once	Enter a value for the recipient's firm; may be left blank if Recipient name is provided. For example: <ToFirm></ToFirm>	string	maxLength=36 whiteSpace=collapse
FirstClassMailIntlRequest / ToAddress1	required once	Three address lines are provided, but only one is required. Use as many as needed for complete address. For example: <ToAddress1>Apartado 3068</ToAddress1>	string	maxLength=36 minLength=1 whiteSpace=collapse
FirstClassMailIntlRequest / ToAddress2	optional	Three address lines are provided, but only one is required. Use as many as needed for complete address. For example: <ToAddress2></ToAddress2>	string	maxLength=36 whiteSpace=collapse
FirstClassMailIntlRequest / ToAddress3	optional	Three address lines are provided, but only one is required. Use as many as needed for complete address. For example: <ToAddress3/>	string	maxLength=36 whiteSpace=collapse

Tag Name	Occurs	Description	Type	Validation
FirstClassMailIntlRequest / ToCity	required once	Recipient's city. For example: <ToCity>PUERTO VALLARTA</ToCity>	string	maxLength=18 minLength=1 whiteSpace=collapse
FirstClassMailIntlRequest / ToProvince	optional	Enter the province for the recipient. For example: <ToProvince>JALISCO</ToProvince>	string	maxLength=9 whiteSpace=collapse
FirstClassMailIntlRequest / ToCountry	required once	The country name entered must match an entry from the USPS-approved International Index of Countries and Localities or be "United States". (http://pe.usps.gov/text/lmm/lmmctry.htm - click on the link for "International Country Listings.") Using a country name not on the list will result in a request failure. For example: <ToCountry>MEXICO</ToCountry>	string	minLength=1 whiteSpace=collapse
FirstClassMailIntlRequest / ToPostalCode	required once	Enter the postal code for the recipient. For example: <ToPostalCode>46807</ToPostalCode>	string	maxLength=9 whiteSpace=collapse
FirstClassMailIntlRequest / ToPOBoxFlag	required once	Indicates whether or not the To Address is a Post Office Box. For example: <ToPOBoxFlag>N</ToPOBoxFlag>	string	whiteSpace=collapse enumeration=Y enumeration=N
FirstClassMailIntlRequest / ToPhone	optional	No format checking is done on international phone numbers. Required when FirstClassMailIntlRequest[ToPOBoxFlag='Y']. For example: <ToPhone>011 52 (322) 222-0069</ToPhone>	string	maxLength=30 whiteSpace=collapse
FirstClassMailIntlRequest / ToFax	optional	No format checking is done on international fax numbers. For example: <ToFax>011 52 (322) 222-0074</ToFax>	string	maxLength=30 whiteSpace=collapse

Tag Name	Occurs	Description	Type	Validation
FirstClassMailIntlRequest / ToEmail	optional	One single, complete, and valid e-mail address is required if tag is used. For example: <ToEmail>cpapple@email.com</ToEmail>	string	maxLength=30 whiteSpace=collapse pattern=([\w\-\.\.])@([\w-]+\.\.))+[a-zA-Z]{2,4}
FirstClassMailIntlRequest / FirstClassMailType	optional	Used to determine the postage rate. See also FirstClassMailIntlRequest/Machinable. For example: <FirstClassMailType>LETTER</FirstClassMailType>	string	default=PARCEL whiteSpace=collapse enumeration=LETTER enumeration=FLAT enumeration=PARCEL
FirstClassMailIntlRequest / ShippingContents	required once		(group)	
FirstClassMailIntlRequest / ShippingContents / ItemDetail	required once repeating up to 5 times		(group)	
FirstClassMailIntlRequest / ShippingContents / ItemDetail / Description	required once	Description of the item. Non-descriptive wording such as 'Gift' will result in an error. For example: <Description>Policy guidelines document</Description>	string	maxLength=56 minLength=1 whiteSpace=collapse
FirstClassMailIntlRequest / ShippingContents / ItemDetail / Quantity	required once	Quantity of the item. Integer value required. For example: <Quantity>1</Quantity>	integer	whiteSpace=collapse minExclusive=0 maxExclusive=1000
FirstClassMailIntlRequest / ShippingContents / ItemDetail / Value	required once	The data entered with this tag provides the value of the set of items. If the item is 2 boxes of 50 pens and the value of each box is \$10.00, "20.00" (2 boxes x \$10.00) should be entered. If the value of each pen is .25 then "25.00" (100 pens x .25) should be entered. For example: <Value>55.00</Value>	decimal	whiteSpace=collapse minExclusive=0 maxExclusive=100000

Tag Name	Occurs	Description	Type	Validation
FirstClassMailIntlRequest / ShippingContents / ItemDetail / NetPounds	required once	Provide the pounds component of the weight of the individual item listed within this ItemDetail. For example: <NetPounds>1</NetPounds>	integer	default=0 whiteSpace=collapse minInclusive=0
FirstClassMailIntlRequest / ShippingContents / ItemDetail / NetOunces	required once	Provide the ounces component of the weight of the individual item listed within this ItemDetail. For example: <NetOunces>5</NetOunces>	decimal	default=0.0 whiteSpace=collapse minInclusive=0
FirstClassMailIntlRequest / ShippingContents / ItemDetail / HSTariffNumber	required once	For commercial items only. If known, the HS tariff number (6-digit) must be based on the Harmonized Commodity Description and Coding System developed by the World Customs Organization. For example: <HSTariffNumber>490110</HSTariffNumber>	string	whiteSpace=collapse maxLength=6 minLength=0 pattern=\d{6} pattern=\d{0}
FirstClassMailIntlRequest / ShippingContents / ItemDetail / CountryOfOrigin	required once	For commercial items only. Country of Origin means the country where the goods originated, e.g. were produced, manufactured, or assembled. It is recommended you supply this information and attach an invoice to the outside to accelerate customs clearance in processing the items. The country name entered must match an entry from the USPS-approved International Index of Countries and Localities or be "United States". (http://pe.usps.gov/text/lmm/lmmctry.htm - click on the link for "International Country Listings.") Using a country name not on the list will result in a request failure. For example: <CountryOfOrigin>United States</CountryOfOrigin>	string	whiteSpace=collapse minLength=0

Tag Name	Occurs	Description	Type	Validation
FirstClassMailIntlRequest / Postage	optional	Use this tag for entering a postage amount, if known. If the tag is present, but the value is blank, the postage will be automatically calculated. For example: <Postage></Postage>	string decimal	length=0 whiteSpace=collapse
FirstClassMailIntlRequest / GrossPounds	required once	Gross pounds and ounces together represent the total package weight, including packing material. For example, a package weighing 3 lbs 8 ounces would have "3" entered here and "8" entered with the "GrossOunces" tag. The Web Tool will check for maximum shipping weight of 70 pounds. Allowable weight may change based on the service used to send package and the destination country. For example: <GrossPounds>4</GrossPounds>	integer	whiteSpace=collapse minInclusive=0
FirstClassMailIntlRequest / GrossOunces	required once	Enter the ounces component of the total package weight with this tag. For example: <GrossOunces>0</GrossOunces>	decimal	whiteSpace=collapse minInclusive=0
FirstClassMailIntlRequest / Machinable	optional	Indicates whether or not the item is machinable. A surcharge is applied to a First-Class Mail International item if it has one or more non-machinable characteristics. See International Mail Manual (IMM) Section 241 for more information. For example: <Machinable>>false</Machinable>	boolean	default=true whiteSpace=collapse
FirstClassMailIntlRequest / ContentType	required once	Specifies the content of the package or envelope. For example: <ContentType>DOCUMENTS</ContentType>	string	whiteSpace=collapse enumeration=MERCHANDISE enumeration=SAMPLE enumeration=GIFT enumeration=DOCUMENTS enumeration=OTHER
FirstClassMailIntlRequest / ContentTypeOther	optional	Required when FirstClassMailIntlRequest[ContentType='OTHER'].	string	maxLength=15 whiteSpace=collapse

Tag Name	Occurs	Description	Type	Validation
FirstClassMailIntlRequest / Agreement	required once	Indicates the requestor's agreement to terms and conditions of mailing. Requires a value of Y to print and in Signature Box along with Current Date (Central Time USA). Any other value returns an error.	string	whiteSpace=collapse enumeration=Y
FirstClassMailIntlRequest / Comments	optional	For future use.	string	maxLength=76 whiteSpace=collapse
FirstClassMailIntlRequest / LicenseNumber	optional	For future use.	string	maxLength=24 whiteSpace=collapse
FirstClassMailIntlRequest / CertificateNumber	optional	For future use.	string	maxLength=24 whiteSpace=collapse
FirstClassMailIntlRequest / InvoiceNumber	optional	For future use.	string	maxLength=24 whiteSpace=collapse
FirstClassMailIntlRequest / ImageType	required once	For example: <ImageType>PDF</ImageType>	string	whiteSpace=collapse enumeration=PDF enumeration=TIF enumeration=NONE
FirstClassMailIntlRequest / ImageLayout	optional	Specified whether the pages are to be returned one per file or all in one file. The current FCMI label is one page so this tag has no effect. For example: <ImageLayout>ONEPERFILE</ImageLayout>	string	default=ONEPERFILE whiteSpace=collapse enumeration=ONEPERFILE enumeration=ALLINONEFILE
FirstClassMailIntlRequest / CustomerRefNo	optional	Written to Postal Manifest Detail record. For example: <CustomerRefNo>Ref #369246</CustomerRefNo>	string	maxLength=30

Tag Name	Occurs	Description	Type	Validation
FirstClassMailIntlRequest / LabelDate	optional	Date the mail will enter the mail stream. No more than three days in the future. Default is day of request. For example: <LabelDate>09/28/2010</LabelDate>	string	whiteSpace=collapse maxLength=10 pattern=\d{1,2}/\d{1,2}/\d\d(\d\d)?
FirstClassMailIntlRequest / HoldForManifest	optional	Restricted use. Holds manifest record for possible inclusion in SCAN request.	string	enumeration=Y enumeration=N
FirstClassMailIntlRequest / EELPFC	optional	Exemption and Exclusion Legend or PFC Code. Currently optional, in the future it may be required for use. Please refer to the International Mail Manual for further information - http://pe.usps.gov/text/imm/immc5_007.htm . To activate check boxes use "30.37a" or "30.37h". For example: <EELPFC>30.37a</EELPFC>	string	whiteSpace=collapse minLength=0 maxLength=35
FirstClassMailIntlRequest / Container	optional	When FirstClassMailIntlRequest[FirstClassMailType='PARCEL'] and [Size='LARGE'], use to specify special containers or container attributes that may affect postage. For example: <Container>RECTANGULAR</Container>	string	whiteSpace=collapse enumeration=RECTANGULAR enumeration=NONRECTANGULAR
FirstClassMailIntlRequest / Size	optional	May be left blank in situations that do not require a Size: (FirstClassMailIntlRequest[FirstClassMailType='LETTER' or 'FLAT']). Defined as follows: REGULAR: Package dimensions are 12" or less; LARGE: Any package dimension is larger than 12". For example: <Size>REGULAR</Size>	string	whiteSpace=collapse enumeration=LARGE enumeration=REGULAR
FirstClassMailIntlRequest / Length	optional	Value must be numeric. Units are inches. Required when FirstClassMailIntlRequest/Size is LARGE. For example: <Width>5.5</Width>	decimal	minExclusive=0.0 totalDigits=10

Tag Name	Occurs	Description	Type	Validation
FirstClassMailIntlRequest / Width	optional	Value must be numeric. Units are inches. Required when FirstClassMailIntlRequest/Size is LARGE. For example: <Length>11</Length>	decimal	minExclusive=0.0 totalDigits=10
FirstClassMailIntlRequest / Height	optional	Value must be numeric. Units are inches. Required when FirstClassMailIntlRequest/Size is LARGE. For example: <Height>11</Height>	decimal	minExclusive=0.0 totalDigits=10
FirstClassMailIntlRequest / Girth	optional	Value must be numeric. Units are inches. Required when FirstClassMailIntlRequest/Size is LARGE, and FirstClassMailIntlRequest/Container is NONRECTANGULAR. For example: <Girth>11</Girth>	decimal	minExclusive=0.0 totalDigits=10
FirstClassMailIntlCertifyRequest	required once	API=FirstClassMailIntlCertify "Certify" signature is for testing and demonstration - does not produce a mailable label	(alias)	

4.1.4 Request Example

```
<FirstClassMailIntlCertifyRequest USERID="xxx">
  <Option/>
  <Revision>2</Revision>
  <ImageParameters/>
  <FromFirstName>John</FromFirstName>
  <FromMiddleInitial>C</FromMiddleInitial>
  <FromLastName>Doe</FromLastName>
  <FromFirm>USPS</FromFirm>
  <FromAddress1>Suite 10000</FromAddress1>
  <FromAddress2>475 Lenfant</FromAddress2>
  <FromCity>Washington</FromCity>
  <FromState>DC</FromState>
  <FromZip5>20260</FromZip5>
  <FromPhone>2025551212</FromPhone>
  <ToName>Jane Smith</ToName>
  <ToFirm></ToFirm>
  <ToAddress1></ToAddress1>
  <ToAddress2>5th floor</ToAddress2>
  <ToAddress3>789 Universal Dr</ToAddress3>
  <ToCity>Ottawa</ToCity>
  <ToCountry>Canada</ToCountry>
  <ToPostalCode>K1A0A1</ToPostalCode>
  <ToPOBoxFlag>N</ToPOBoxFlag>
```

```
<ToPhone>5555555555</ToPhone>
<ToFax>88888888888888</ToFax>
<ToEmail>b@aol.com</ToEmail>
<FirstClassMailType>PARCEL</FirstClassMailType>
<ShippingContents>
  <ItemDetail>
    <Description>Description 1</Description>
    <Quantity>1</Quantity>
    <Value>1.11</Value>
    <NetPounds>1</NetPounds>
    <NetOunces>1</NetOunces>
    <HSTariffNumber>123456</HSTariffNumber>
    <CountryOfOrigin>Brazil</CountryOfOrigin>
  </ItemDetail>
  <ItemDetail>
    <Description>Description 2</Description>
    <Quantity>2</Quantity>
    <Value>2.22</Value>
    <NetPounds>0</NetPounds>
    <NetOunces>2</NetOunces>
    <HSTariffNumber>234567</HSTariffNumber>
    <CountryOfOrigin>Canada</CountryOfOrigin>
  </ItemDetail>
</ShippingContents>
<GrossPounds>3</GrossPounds>
<GrossOunces>2</GrossOunces>
```

```
<Machinable>>false</Machinable>  
<ContentType>GIFT</ContentType>  
<Agreement>Y</Agreement>  
<Comments>FirstClassMailIntl Comments</Comments>  
<ImageType>TIF</ImageType>  
<ImageLayout>ONEPERFILE</ImageLayout>  
<HoldForManifest>N</HoldForManifest>  
<EELPFC>30.37a</EELPFC>  
<Container>RECTANGULAR</Container>  
<Size>REGULAR</Size>  
<Length>10.5</Length>  
<Width>5.5</Width>  
<Height>5.5</Height>  
<Girth>5.5</Girth>  
</FirstClassMailIntlCertifyRequest>
```

4.2 First Class Mail International Response

4.2.1 Response Diagram

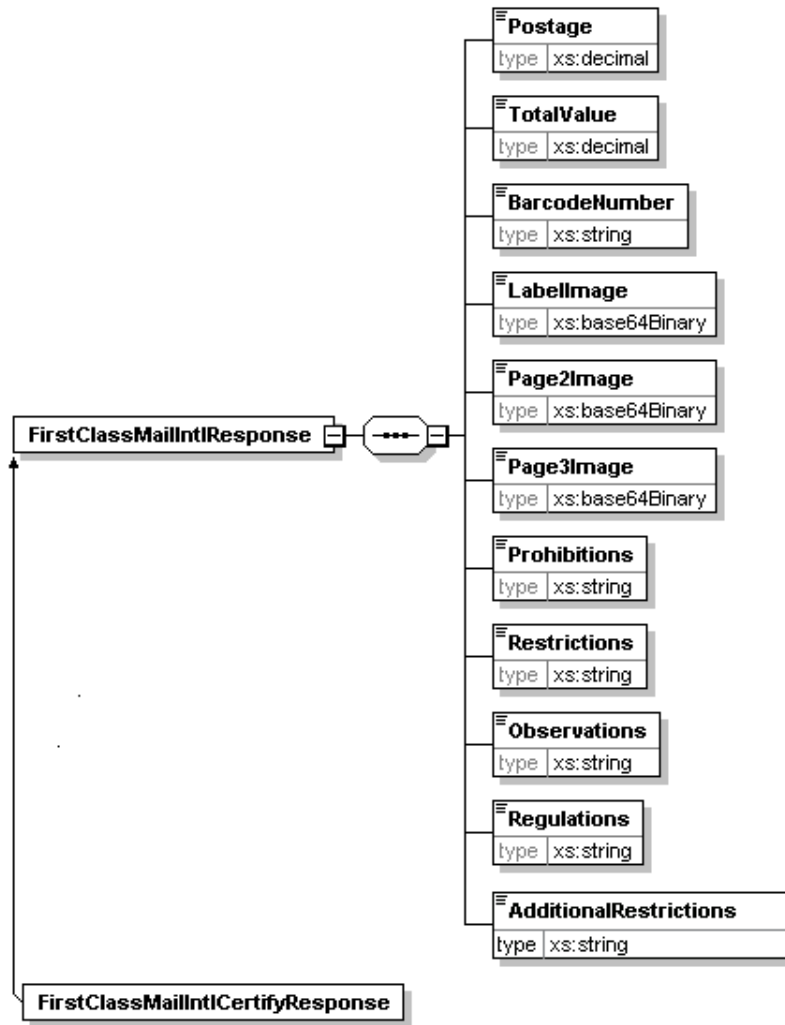

4.2.2 Response Parameters

Tag Name	Occurs	Description	Type	Validation
FirstClassMailIntlResponse	required once		(group)	
FirstClassMailIntlResponse / Postage	required once	Postage amount	decimal	
FirstClassMailIntlResponse / TotalValue	required once	Value of all items being shipped	decimal	
FirstClassMailIntlResponse / BarcodeNumber	required once	Mail service related barcode, may be empty	string	
FirstClassMailIntlResponse / LabelImage	required once	Encoded images of label. (may be empty depending upon layout selection or items shipped)	base64Binary	
FirstClassMailIntlResponse / Page2Image	required once	Encoded images of label. (may be empty depending upon layout selection or items shipped)	base64Binary	
FirstClassMailIntlResponse / Page3Image	required once	Encoded images of label. (may be empty depending upon layout selection or items shipped)	base64Binary	
FirstClassMailIntlResponse / Prohibitions	required once	List of items prohibited from mailing based on country of destination	string	
FirstClassMailIntlResponse / Restrictions	required once	Restrictions on items being shipped based on country of destination	string	
FirstClassMailIntlResponse / Observations	required once	Additional mailing information based on country of destination	string	
FirstClassMailIntlResponse / Regulations	required once	Additional regulations for shipping to destination country	string	
FirstClassIntlResponse / AdditionalRestrictions	required once	Additional restrictions on items being shipped to destination country	string	
FirstClassMailIntlCertifyResponse	required once		(alias)	

4.2.4 Response Example

```
<?xml version="1.0"?>
<FirstClassMailIntlCertifyResponse>
  <Postage>25.15</Postage>
  <TotalValue>3.33</TotalValue>
  <BarcodeNumber>LJXXXXXXXXXUS</BarcodeNumber>
  <LabelImage>SUkqAAgAAAASAP4ABAABAAAAAAAAAAAAABBAABAAAArgYAAAEBB<!--37678 suppressed-->=</LabelImage>
  <Page2Image/>
  <Page3Image/>
  <Prohibitions>Arms, ammunition, weapons. Articles in hermetical<!--813 suppressed-->.</Prohibitions>
  <Restrictions>The importation of personal articles is limited t<!--839 suppressed-->s</Restrictions>
  <Observations>Articles that do not meet the requirements mentio<!--90 suppressed-->.</Observations>
  <Regulations>Country Code: CN Reciprocal Service Name: Interna<!--525 suppressed-->|</Regulations>
  <AdditionalRestrictions/>
</FirstClassMailIntlCertifyResponse>
```