

LBNL-5342E

**ERNEST ORLANDO LAWRENCE  
BERKELEY NATIONAL LABORATORY**

---

# **Energy Efficiency Improvement and Cost Saving Opportunities for the Concrete Industry**

## **An ENERGY STAR<sup>®</sup> Guide for Energy and Plant Managers**

*Katerina Kermeli  
Ernst Worrell  
Eric Masanet*

**Environmental Energy Technologies Division**

**Sponsored by the U.S. Environmental  
Protection Agency**

**December 2011**

## **Disclaimer**

This document was prepared as an account of work sponsored by the United States Government. While this document is believed to contain correct information, neither the United States Government nor any agency thereof, nor The Regents of the University of California, nor any of their employees, makes any warranty, express or implied, or assumes any legal responsibility for the accuracy, completeness, or usefulness of any information, apparatus, product, or process disclosed, or represents that its use would not infringe privately owned rights. Reference herein to any specific commercial product, process, or service by its trade name, trademark, manufacturer, or otherwise, does not necessarily constitute or imply its endorsement, recommendation, or favoring by the United States Government or any agency thereof, or The Regents of the University of California. The views and opinions of authors expressed herein do not necessarily state or reflect those of the United States Government or any agency thereof, or The Regents of the University of California.

Ernest Orlando Lawrence Berkeley National Laboratory is an equal opportunity employer.

**Energy Efficiency Improvement and Cost Saving Opportunities for the  
Concrete Industry**

**An ENERGY STAR<sup>®</sup> Guide for Energy and Plant managers**

Katerina Kermeli, Ernst Worrell, and Eric Masanet

Energy Analysis Department  
Environmental Energy Technologies Division  
Ernest Orlando Lawrence Berkeley National Laboratory  
University of California  
Berkeley, CA 94720

December 2011

This work was funded by U.S. Environmental Protection Agency's Climate Protection Partnerships Division as part of ENERGY STAR. ENERGY STAR is a government-backed program that helps businesses protect the environment through superior energy efficiency. The work was supported by the U.S. Environmental Protection Agency through the U.S. Department of Energy Contract No. DE-AC02-05CH11231.



# **Energy Efficiency Improvement and Cost Saving Opportunities for the Concrete Industry**

## **An ENERGY STAR® Guide for Energy and Plant Managers**

Katerina Kermeli, Ernst Worrell, and Eric Masanet

Energy Analysis Department  
Environmental Energy Technologies Division  
Ernest Orlando Lawrence Berkeley National Laboratory

December 2011

### **ABSTRACT**

The U.S. concrete industry is the main consumer of U.S.-produced cement. The manufacturing of ready mixed concrete accounts for about 75% of the U.S. concrete production following the manufacturing of precast concrete and masonry units. The most significant expenditure is the cost of materials accounting for more than 50% of total concrete production costs - cement only accounts for nearly 24%. In 2009, energy costs of the U.S. concrete industry were over \$610 million. Hence, energy efficiency improvements along with efficient use of materials without negatively affecting product quality and yield, especially in times of increased fuel and material costs, can significantly reduce production costs and increase competitiveness.

The Energy Guide starts with an overview of the U.S. concrete industry's structure and energy use, a description of the various manufacturing processes, and identification of the major energy consuming areas in the different industry segments. This is followed by a description of general and process related energy- and cost-efficiency measures applicable to the concrete industry. Specific energy and cost savings and a typical payback period are included based on literature and case studies, when available. The Energy Guide intends to provide information on cost reduction opportunities to energy and plant managers in the U.S. concrete industry. Every cost saving opportunity should be assessed carefully prior to implementation in individual plants, as the economics and the potential energy and material savings may differ.



## Table of Contents

1	Reducing Energy Use to Meet Energy, Cost, and Environmental Targets.....	2
2	The U.S. Concrete Industry .....	3
3	Energy Use in the U.S. Concrete Industry.....	6
	3.1 Ready Mixed Concrete Production.....	8
	3.2 Concrete Masonry Units (CMUs) Production .....	10
	3.3 Precast Concrete Production.....	11
4	General Practices for Managing Your Energy Use.....	13
	4.1 Effective Principles for Energy Savings .....	13
	4.2 Plant Energy Assessments .....	15
	4.3 Energy Teams .....	16
	4.4 Employee Awareness.....	17
	4.5 Energy Monitoring Systems .....	18
5	Energy Efficiency Opportunities for Common Plant Systems .....	20
	5.1 Building Lighting.....	20
	5.2 Building HVAC .....	24
	5.3 Motors .....	28
	5.4 Compressed Air .....	33
	5.5 Pumps.....	39
	5.6 Hot Water and Steam Systems.....	43
	5.7 Chillers.....	48
	5.8 Dust Collectors.....	50
6	Energy Efficiency Opportunities for Concrete Production Processes .....	52
	6.1 Pneumatic Conveying .....	52
	6.2 Cold Weather Concreting .....	54
	6.3 Humidity Control .....	57
	6.4 Mixing.....	58
	6.5 Truck Operation and Fleet Management .....	61
	6.6 Curing .....	62
	6.7 Returned Concrete .....	66
	6.8 Process Water.....	69
	6.9 Miscellaneous .....	71
7	Summary.....	77
	Acknowledgements.....	81
	Glossary .....	82
	References.....	86
	Appendix A: ENERGY STAR Energy Management Matrix.....	96
	Appendix B: Basic Energy Efficiency Actions for Plant Personnel.....	100
	Appendix C: Support Programs for Industrial Energy Efficiency Improvement .....	101
	Appendix D: Teaming Up to Save Energy Checklist .....	111

## Figures

Figure 1. U.S ready mixed concrete and cement production from 1975 up to 2010 .....	5
Figure 2. Energy costs per cubic yard of ready mixed concrete, 1998-2009.....	7
Figure 3. Energy expenditures in the U.S. concrete industry (excluding concrete delivery) ...	8
Figure 4. Ready mixed concrete production .....	9
Figure 5. Elements of strategic energy management, ENERGY STAR Guidelines for Energy Management.....	14
Figure 6. Lighting placement and controls .....	22
Figure 7. Simplified schematic of a steam production and distribution system. ....	43
Figure 8. System capabilities and design parameters for materials with very good air retention (i.e. cement and fly ash).....	54

## Tables

Table 1. Ready mixed concrete production in 2010, by state .....	4
Table 2. Estimated energy consumption in the U.S. concrete industry in 2007 .....	6
Table 3. Energy use in the U.S. ready mixed concrete plants .....	10
Table 4. Energy use in the U.S. concrete masonry unit plants .....	11
Table 5. Energy use in the U.S. precast concrete plants .....	12
Table 6. Performance comparison of lighting sources.....	21
Table 7. Alternatives for compressed air .....	36
Table 8. Summary of general energy efficiency measures .....	78
Table 9. Summary of cost efficiency measures specific to concrete production.....	80



## **Energy Efficiency: A Commitment to Good Business**

Finding effective ways to manage energy helps your company keep costs down and stay competitive. Did you know a well-run energy program can reduce energy costs by 3% to 10% annually? An added bonus is that improving energy efficiency reduces waste and emissions - things that cost your company money!

Organizations often differ in energy performance, even when they belong to the same industry, operate under the same market conditions, and use the same equipment. Why the big performance gap?

Research shows that high performers adopt a structured approach to energy management. They establish policies and procedures for long-term results, have senior management's support, allocate staff and resources, establish goals, develop management structures that empower staff to address energy efficiency issues directly, and adopt a philosophy of continuous improvement.

This *Energy Guide* provides the information you need to establish a structure that will work for your company and identify cost-effective practices and technologies to reduce energy use throughout your company's operations.

# 1 Reducing Energy Use to Meet Energy, Cost, and Environmental Targets

Volatile energy markets, growing competition, and worldwide regulation of greenhouse gas emissions are influencing many U.S. manufacturers to consider energy management as an untapped opportunity. They are finding that production costs can be reduced without negatively affecting the yield and quality of products while reducing energy consumption and costs.

Energy efficiency, which includes sound plant-wide energy management practices combined with energy-efficient technologies, offers additional benefits, such as product quality improvement, increased production, and increased process efficiency—all of which can lead to productivity gains. As a component of a company's overall environmental strategy, energy efficiency improvements often lead to reductions in emissions of greenhouse gases (GHGs) and other important air pollutants. Investments in energy efficiency are a sound and key business strategy in today's manufacturing environment.

This Energy Guide provides an overview of available measures for energy efficiency in the concrete industry. Specific energy consumption can vary widely among different plants, and depends on the type of product manufactured, climate conditions, and condition of equipment. This Energy Guide is concerned with the most important systems, equipment, processes and practices that account for the bulk of energy consumption in the concrete industry.

This Energy Guide is offered as part of the ENERGY STAR<sup>®</sup> program. Additional energy management resources specific to ready mixed concrete production can be found on the [ENERGY STAR Industries in Focus](#) website<sup>1</sup>.

ENERGY STAR<sup>®</sup> is a voluntary partnership program of the U.S. Environmental Protection Agency (EPA) that helps U.S. industry improve its competitiveness through increased energy efficiency and reduced environmental impact. Through ENERGY STAR, EPA stresses the need for strategic corporate energy management and provides a host of energy management tools and strategies to help companies build such programs. For further information on ENERGY STAR and its tools, visit <http://www.energystar.gov/industry>.

The Energy Guide is organized into the following sections:

- Section 2 briefly describes the U.S. concrete industry.
- Section 3 estimates the energy use in the U.S. concrete industry, covers how energy is used in making concrete products in the U.S. and is helpful in identifying where to focus on energy reductions in your plant.
- Section 4 outlines steps to follow in designing an energy management program.
- Section 5 and 6 identify savings in each of the plant systems or operation. All efficiency measures are technically proven, commercially available, and have an extensive track record.
- Section 7 provides a brief summary.

---

<sup>1</sup> See: [www.energystar.gov/industry](http://www.energystar.gov/industry).

## 2 The U.S. Concrete Industry

Concrete is produced from the combination of aggregates (sand and rocks), and a binding agent, commonly referred to as paste. Through a chemical reaction called hydration, the paste, made of Portland cement and water, hardens, and binds the aggregates together to create a hard, stone-like product known as concrete. Typically, concrete consists of about 10-15% cement, 60-75% aggregates and 15-20% water (PCA, 2011a). Cement, up to a certain extent, can be replaced by supplementary cementitious materials (SCMs), such as, pozzolans (i.e. fly ash, silica fume, calcined shale) and slags (byproduct from the iron and steel industry). Chemical admixtures can also be added, providing special characteristics to the concrete mix such as increasing or decreasing the hydration rate or increasing corrosion resistance of the steel reinforcement (PCA, 2011a).

**Concrete** = aggregates + binding agent (Portland cement, water)

The characteristics of concrete: plastic and workable within the first few hours of manufacturing, strong when left to harden, and economical, have proved to be the ideal material for many applications in the building industry. It is one of the most commonly used materials on earth and is used in the construction of all types of buildings, houses, bridges, highways and dams. Cement content in concrete mixtures varies between 10 to 15% on a weight basis, depending on product specifications. In recent years, greater use of supplementary cementitious materials (SCMs), and continuous improvement in concrete production and quality have led to decreases in the amount of cement used in concrete manufacturing (Lobo and Gaynor, 2006; Athena Sustainable Materials Institute, 1993).

Due to the economic crisis, 2010 cement production in the United States amounted to 63 million metric tons, the lowest since 1982 (van Oss, 2011). Ready mixed concrete (RMC) accounts for about 75% of the overall annual concrete production, followed by the production of concrete masonry units (CMUs) and precast concrete (13%). Nearly 6% of concrete is produced at the contractor's site, while the rest is used in other activities like well lining and mining (Choate, 2003). In 2010, RMC production reached 458 million metric tons (258 million yd<sup>3</sup>) and was responsible for about 73% of cement sales (Mullings, 2011; van Oss, 2011). Moreover, concrete product manufacturers were responsible for 12% of cement sales, contractors (mostly road paving) for 10%, and users of building materials and others for another 5% (van Oss, 2011). In 2010 ready mixed concrete production remained low, as spending in the construction sector was affected by the continued depression in the housing market, high levels of housing foreclosures, limited State tax revenues, credit tightening, and increased unemployment rates (van Oss, 2011).

Concrete plants are constructed close to their market, the building industry, and can be found throughout the United States. Table 1 shows the ready mixed concrete production in all States. The estimated number of concrete companies was around 5,000 in 1978, a number which dropped significantly to 3,700 companies in 1994, to yet further decrease between 2,000 to 2,500 in 2010 (Lobo and Gaynor, 2006; Coppinger, 2011). The drop is attributed to consolidation in the industry. In 2010, the ready mixed concrete companies operated about 6,000 plants (NRMCA, 2011). The number of mixer trucks in use decreased from 80,000 a few years ago, to 68,000 in 2010. Most of the companies, along with the decrease in ready mixed concrete

production due to the low demand in the construction sector, also retired old truck mixers, sold a share of their fleet, and parked and removed the tags on a number of them (Jones et al., 2010). In 2010, the U.S ready mixed concrete industry employed about 120,000 people, while in 2008 the number of employees was in the range of 125,000-140,000 (NRMCA, 2008).

**Table 1. Ready mixed concrete production in 2010, by state**

State	Production yd <sup>3</sup>	State	Production yd <sup>3</sup>
Alabama	3,685,750	Montana	952,696
Alaska	501,590	Nebraska	3,630,313
Arizona	5,397,925	Nevada	3,080,504
Arkansas	2,780,531	New Hampshire	680,683
California	22,644,866	New Jersey	4,124,696
Colorado	5,390,682	New Mexico	2,218,618
Connecticut	1,723,552	New York	8,458,442
Delaware	633,249	North Carolina	5,807,745
District of Columbia	401,126	North Dakota	1,497,459
Florida	13,105,692	Ohio	8,643,522
Georgia	6,312,228	Oklahoma	5,260,955
Hawaii	961,879	Oregon	2,237,065
Idaho	1,422,402	Pennsylvania	8,871,725
Illinois	8,938,522	Puerto Rico	2,969,024
Indiana	5,446,722	Rhode Island	342,103
Iowa	5,259,145	South Carolina	3,421,474
Kansas	4,306,556	South Dakota	1,641,725
Kentucky	3,129,107	Tennessee	4,515,756
Louisiana	10,074,204	Texas	37,131,423
Maine	681,459	Utah	3,757,070
Maryland	3,565,037	Vermont	378,893
Massachusetts	2,494,141	Virginia	5,126,485
Michigan	5,709,548	Washington	4,856,909
Minnesota	4,408,256	West Virginia	1,565,202
Mississippi	2,842,257	Wisconsin	5,257,665
Missouri	5,741,235	Wyoming	1,184,286
		<i>n.a.</i>	2,551,238
		<b>Overall</b>	<b>257,721,337</b>

Source: Mullings, 2011

According to the National Ready Mixed Concrete Association's (NRMCA) survey, in 2010, the average concrete production per plant in the U.S. was 31,500 yd<sup>3</sup> per year, while the average number of truck mixers owned by a ready mixed concrete facility was 159 (median value 83) (NRMCA, 2011). In the U.S. only 20 to 25% of ready mixed concrete production occurs in a central mixer. The majority of RMC is mixed in the truck's drum. In contrast, in Europe and Japan, the entire RMC production takes place at central plants (Lobo and Gaynor, 2006).

Concrete production follows the development of the economy. As can be seen in Figure 1, in 1975, RMC production was around 310 million metric tons (175 million yd<sup>3</sup>), and in 2005 it rose to approximately 810 million metric tons (455 million yd<sup>3</sup>); an average annual growth of 3.2%. In 2010, due to the economic downturn and the ongoing depressed construction market, ready mixed concrete production dropped to 1994 levels of about 458 million metric tons (258 million yd<sup>3</sup>); a decrease of 43% within 5 years.

1000 metric tons

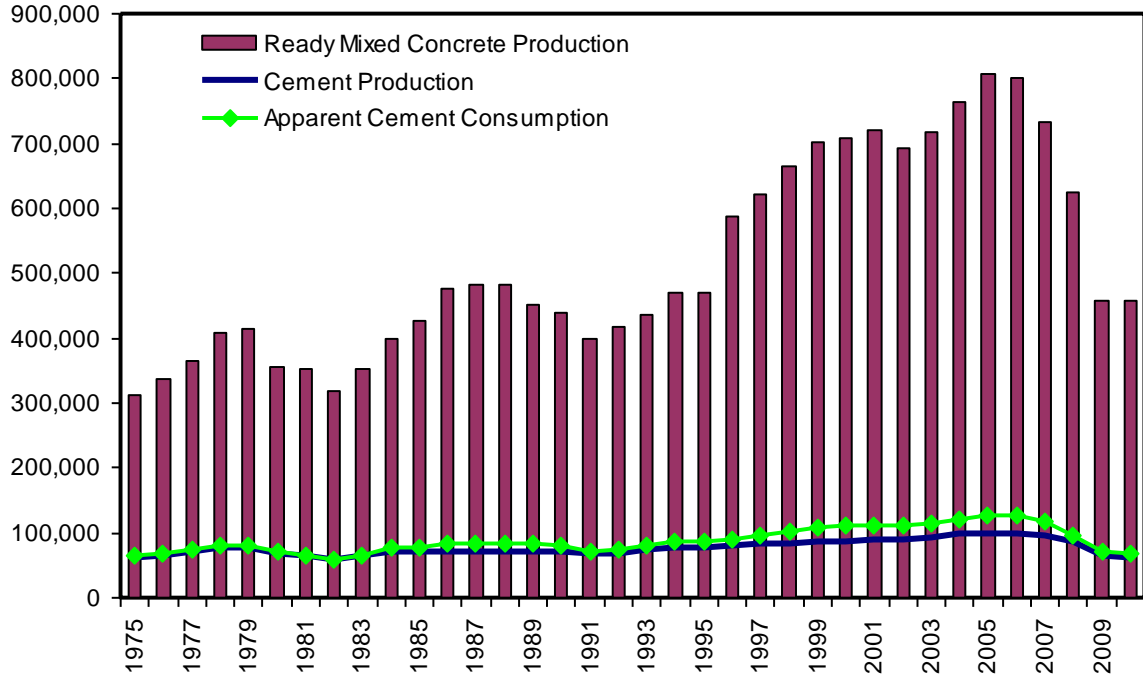

**Figure 1. U.S ready mixed concrete and cement production from 1975 up to 2010**

Note: Apparent cement consumption is defined by the USGS (various years), as the cement production in the U.S. (including cement production from imported clinker), plus imports of hydraulic cement, minus exports of hydraulic cement, minus the change in yearend cement stocks.

Source: van Oss, various years; Olivarri, 2011; Mullings, 2011

### 3 Energy Use in the U.S. Concrete Industry

According to most recent data, in 2009, the U.S. concrete industry spent about \$610 million on energy for use at the plant site (U.S. Census, 2010). Of this, approximately \$330 million were spent on fuels and \$280 million on electricity. While energy costs account only for a small fraction of the overall concrete production costs, in 2009, the energy expenditures of the U.S. concrete industry were more than half the energy expenditures of the U.S. cement industry (\$1.1 billion) (U.S. Census, 2010). For the same year, fuel costs for ready mixed concrete delivery were estimated at \$720 million<sup>2</sup>. The energy consumption in the different segments of the U.S. concrete industry was estimated using data from the U.S. Census Bureau's 2007 Economic Census<sup>3</sup> (U.S. Census, 2009). Although energy expenditure data is also available for 2008 and 2009, the reporting format does not allow us to disaggregate to the different segments of the concrete industry. Therefore, the energy consumption in Table 2 is based on 2007.

**Table 2. Estimated energy consumption in the U.S. concrete industry in 2007**

	Ready Mixed Concrete	Bricks and Blocks	Pipes and Others	Total
Fuel Consumption*	22	5	8	36
Electricity Consumption	9	3	6	18
<b>Total Final Energy Consumption</b>	<b>32</b>	<b>8</b>	<b>14</b>	<b>53</b>
Electricity Losses	18	5	10	33
<b>Total Primary Energy Consumption</b>	<b>49</b>	<b>13</b>	<b>24</b>	<b>87</b>

\* Various types of fuels were used in the different concrete industry segments. According to the PCA survey (Marceau et al., 2007) the fuel used in ready mixed concrete facilities was 60% diesel and 40% natural gas, in concrete masonry facilities 28% diesel and 72% natural gas, and in precast concrete facilities 14% diesel, 51% natural gas, 5% gasoline, 8% LPG, and 22% fuel oil.

Sources: U.S. Census, 2009; EIA, 2011b; EIA, 2010

The 2007 primary energy use in the U.S. concrete industry was estimated at 87 TBtu; see Table 2. Although electricity consumption was reported by the 2007 Economic Census, fuel consumption had to be estimated by dividing the 2007 fuel expenditures reported by the Economic Census, by the 2007 average U.S. fuel prices; which can result in significant uncertainties. The 2007 fuel use in concrete trucks, mainly diesel, for concrete delivery was estimated at about 64 TBtu<sup>4</sup>. Natural gas and diesel oil were the main fuels used in the RMC,

<sup>2</sup> According to the NRMCA's 2010 Fleet Benchmarking and Cost Survey, in 2009, fuel expenses for concrete delivery were \$2.81 per yd<sup>3</sup> of concrete (Jones et al., 2010). In 2009, the ready mixed concrete production was approximately 258,000,000 yd<sup>3</sup>.

<sup>3</sup> The fuel consumption was estimated by dividing the 2007 U.S. fuel expenditures reported by the 2007 Economic Census (U.S. Census, 2009) by the 2007 U.S. average fuel prices. Industrial natural gas price of \$7.68 per 1000 ft<sup>3</sup>, diesel price of \$2.89 per gallon, gasoline price of \$2.81 per gallon, fuel oil price of \$1.38 per gallon (EIA, 2011a), and liquefied petroleum gas (LPG) price of \$1.5 per gallon (EIA, 2010). Fuel consumption does not take into account the fuel use for power generation. Primary energy consumption takes into account electricity losses and it was estimated using the 2007 U.S. average conversion factor of 9,884 Btu per kWh (EIA, 2011b).

<sup>4</sup> According to the NRMCA's 2008 Fleet Benchmarking and Cost Survey, in 2007, the average fuel use in concrete trucks was 1.16 gallons per yd<sup>3</sup> of concrete (Vickers, 2009).

CMUs and precast concrete industries. Liquefied petroleum gas, fuel oil and gasoline were only used in the manufacture of precast concrete (Marceau et al., 2007).

During the last decade, energy costs in the U.S concrete industry have increased significantly. Figure 2 plots the energy costs to produce and deliver one cubic yard of ready mixed concrete in the period 1998-2009. The increasing energy costs can be attributed to increasing energy prices. During this period, diesel, the predominant fuel in ready mixed concrete production and delivery, has experienced rapid price increases. Between 1999 and 2008, the average price of diesel in the United States increased from \$1.12 per gallon to \$3.80 per gallon while for the same period the average industrial price for natural gas, increased from \$3.12 per 1000 ft<sup>3</sup> to \$9.65 per 1000 ft<sup>3</sup> (U.S. DOE, 2011a; U.S. DOE, 2011b).

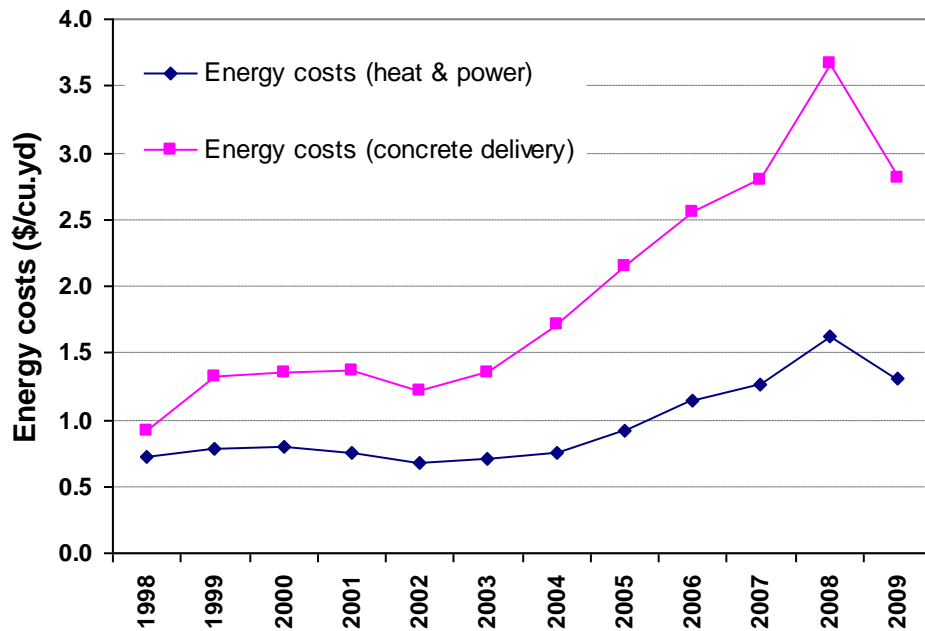

**Figure 2. Energy costs per cubic yard of ready mixed concrete, 1998-2009**

*Sources: Carew et al., 2007; EIA, 2011b; Olivarri., 2011; U.S. Census, 1995, 1996, 1997, 1998, 2002, 2006, 2009, 2010; Vickers, 2009*

Figure 3 shows the overall energy expenditures in the U.S. concrete industry and the energy expenditures of the U.S. RMC industry for the period 1992-2009. Since 2002, energy expenditures for both fuel and electricity have increased drastically. This is mainly due the increase in concrete production and energy prices. With the economic downturn, the 2009 concrete production and energy use decreased rapidly. From 2008 to 2009, fuel expenses in the RMC industry decreased by more than 40%. This is mainly due to the rapid decrease in throughput.

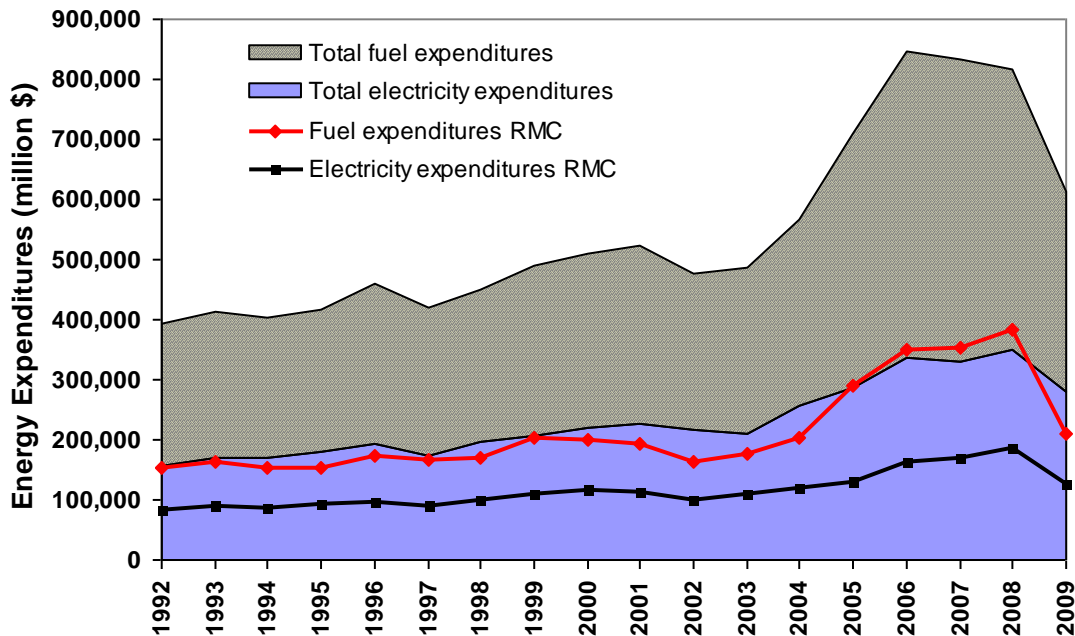

**Figure 3. Energy expenditures in the U.S. concrete industry (excluding concrete delivery)**

Sources: U.S. Census, 1995, 1996, 1997, 1998, 2002, 2006, 2009, 2010

The following sections describe the basic processes and typical energy consumption in the ready mixed concrete, precast concrete and concrete masonry manufacturing plants. Energy use and intensity may vary from plant to plant.

### 3.1 Ready Mixed Concrete Production

The raw materials needed in concrete production, cement, fine and coarse aggregates, admixtures and cementitious replacements (i.e. fly ash, blast furnace slag), are transferred to the concrete plant site via truck, rail or barge. Aggregates are usually stored in open areas on site, while raw materials sensitive to moisture, such as fly ash and cement, require storage in silos. Cement is transferred via pneumatic conveyors or bucket elevators to silos, while coarse and fine aggregates are transferred via front end loaders, clam shell cranes, belt conveyors or bucket elevators to elevated bins. All materials are then fed by screw conveyors or gravity to the weigh hoppers, where the right material proportions are combined (U.S. EPA, 2004).

Ready mixed concrete production can take place in the truck (dry batch), at the plant (wet batch), or partially in the truck and partially at the plant (half wet batch), see Figure 4.

**Transit mixed concrete (dry batch process).** In transit mixed concrete production, Portland cement, and fine and coarse aggregates are weighed individually and are directly dry fed to the truck’s drum mixer. Water and the additional admixtures are then fed into the drum. Concrete is produced while the truck is in route to the job site.

**Shrink mixed concrete (half wet batch process).** Concrete is initially mixed in the plant’s central mixer and then loaded in the truck’s drum mixer where the last stages of mixing take



place. The required mixing time is specified according to the desired product characteristics and after uniformity tests are conducted (NRMCA, 2011b).

**Central mixed concrete (wet batch process).** In the wet batch process, raw materials are mixed in the central mixer. RMC is then transferred to the job site via an agitating or a non-agitating unit (short distances).

The main types of central mixers are the i) tilt drum mixers, ii) vertical shaft mixers (pan and planetary mixers), iii) non-tilting drum mixers, and iv) horizontal shaft mixers (CPBM, 2007). The most commonly used type of central mixer is the tilt drum mixer. Tilt drum mixers are characterized by high efficiency, but also by significant operation and maintenance costs, since they are composed of many moving parts which are exposed daily to heavy loads. Typical tilt drum capacities range between 2 to 15 yd<sup>3</sup> (1.5 to 11.5 m<sup>3</sup>) (Lobo and Gaynor, 2006). Horizontal shaft mixers are reported to produce higher strength concrete but are more energy intensive than the tilt drum mixer (NRMCA, 2011b).

Pan mixers are characterized by low height and rapid mixing. These attributes made them favorable in the past, but because they wear out quickly, they are not currently widely used (Lobo and Gaynor, 2006). Pan mixers are lower capacity mixers, with a typical capacity ranging between 4 to 5 yd<sup>3</sup>, and are mainly used in the precast concrete plants.

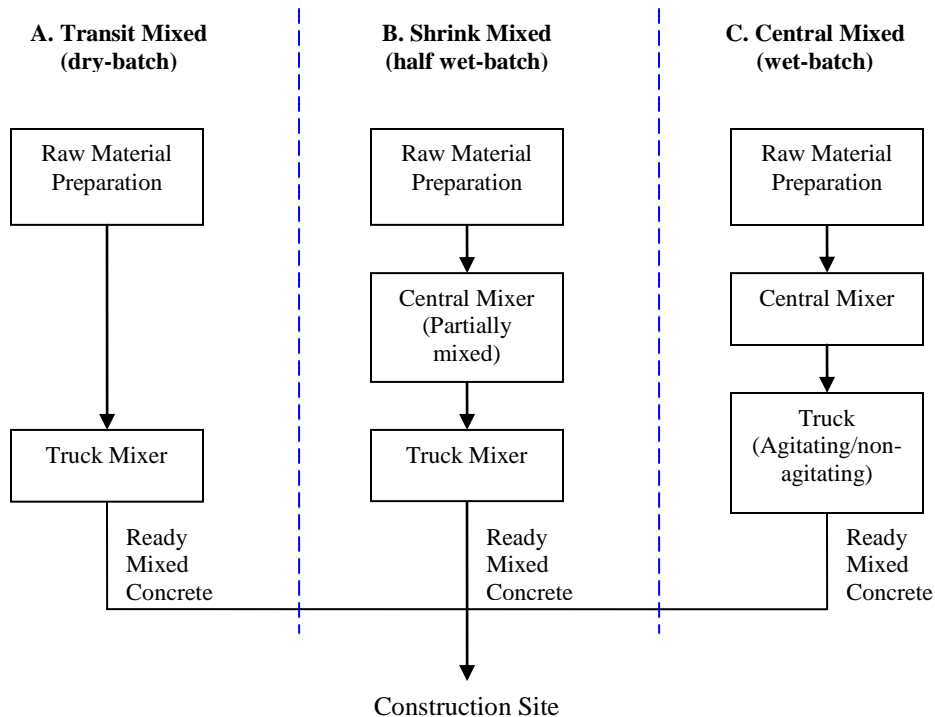

**Figure 4. Ready mixed concrete production**

In 2009, the U.S ready mixed concrete industry spent approximately \$340 million on fuel and electricity for heat and power (U.S. Census, 2010) while delivery fuel costs for fresh concrete delivery were estimated at around \$720 million.

Energy intensities and fuel type used in a ready mixed concrete production facility vary. According to a survey of 47 facilities across the U.S. (Marceau et al., 2007), most of the energy used was diesel oil (24%) and natural gas (26%) in boilers for hot water production and building heat, diesel oil in light trucks (16%), and electricity (35%) throughout the plant. An overview of the energy breakdown is shown in Table 3. Electricity is used to power the on-site concrete mixer (65%), dust extractor (3%), and water pump (20%) (Obara et al., no date). A fraction of electricity is also used for lighting.

**Table 3. Energy use in the U.S. ready mixed concrete plants**

Energy Types	kBtu/ton concrete				kBtu/yd <sup>3</sup> concrete			
	Ready Mixed Concrete (3,000 psi)				Ready Mixed Concrete (3,000 psi)			
	light trucks	boiler	building heat	throughout plant	light trucks	boiler	building heat	throughout plant
<b>Diesel</b>	2.5	3.4	0.4	6.2	4.9	6.6	0.7	12.2
<b>Electricity</b>	n/a	n/a	n/a	5.5 (1.6 kWh)	n/a	n/a	n/a	10.7 (3.1 kWh)
<b>Natural gas</b>	0.0	3.1	1.0	4.2	0.0	6.1	2.0	8.1
<b>Total</b>	2.5	6.5	1.4	15.9	4.9	12.7	2.8	31.0

Note: Energy Intensity is presented for a 3,000 psi Concrete Mix, as it is the one most commonly used (around 90% market share). Concrete with strength ranging between 4,000 and 4,500 psi has a market share of 8%, while higher strength concrete only 1-2%. To convert 1 kBtu/yd<sup>3</sup> of concrete to 1 kBtu/ton of concrete divide with 1.96.

Source: Marceau et al., 2007

According to the PCA survey, Marceau et al. (2007), the average specific energy consumption in the U.S ready mixed concrete industry is 31 kBtu/yd<sup>3</sup> (43 MJ/m<sup>3</sup>) of concrete. The specific energy consumption of a ready mixed concrete facility depends strongly on climate conditions and the state of the equipment. According to literature (*fib*, 2003; *fib*, 2004; Nielsen and Glavind, 2007), energy intensities are seen to vary widely from 38 kBtu/yd<sup>3</sup> (50 MJ/m<sup>3</sup>) up to several hundreds. In cold climates the energy requirements are higher, as the batching water, and sometimes the aggregates, need to be pre-heated.

It is estimated that on average, the energy consumption for ready mixed concrete delivery is on the same order of magnitude as the energy consumption at the concrete plant (Nielsen and Glavind, 2007).

### 3.2 Concrete Masonry Units (CMUs) Production

In the concrete masonry plant (concrete block plant), the processes involved are similar to those in a ready mixed plant, with the addition of molding and curing. Although concrete masonry plants produce various sizes of blocks, the standard block measures 8x8x16 inches.

“No slump” (low water content) concrete is placed in molds. After the molds are removed, the curing process starts. The curing temperature can vary from room temperature to 190°F (90°C)

(Marceau et al., 2007). Curing is influenced by i) kiln design and insulation ii) continuous or batch curing iii) local temperatures iv) season of the year and v) curing temperature (Marceau et al., 2007; Nisbet et al. 2000).

In 2007<sup>5</sup>, the U.S. block and brick manufacturing industry spent over \$110 million on energy. Of this, 57% was spent on fuel and 53% was spent on electricity (U.S. Census, 2009).

A breakdown of the energy intensity in U.S. concrete masonry unit facilities is shown in Table 4. Curing is the most energy intensive step, accounting for about 60% of the plant’s energy consumption. Energy consumed (mainly diesel) for the operation of light trucks, accounts for 24% of energy consumption in the plant. The rest of the energy consumption is electricity used throughout the plant (13%).

**Table 4. Energy use in the U.S. concrete masonry unit plants**

Energy Types	kBtu/100 CMUs or kBtu/yd <sup>3</sup> *		
	CMUs (CMU Mix)		
	light trucks: fork lift, loaders, etc.	kiln and industrial boiler	throughout plant
<b>Diesel</b>	57.5	0.0	57.5
<b>Electricity</b>	n/a	n/a	31.4 (9.2 kWh)
<b>Natural gas</b>	0.0	146.3	146.3
<b>Total</b>	57.5	146.3	235.1

Notes: On average, 1 yd<sup>3</sup> of concrete CMU mix will yield approximately 100 CMUs. The consistency of the CMU mix is different from the regular concrete mix. To convert 1 kBtu/yd<sup>3</sup> of concrete to 1 kBtu/ton of concrete divide with 1.53.

Source: Marceau et al., 2007

### 3.3 Precast Concrete Production

The processes involved in precast concrete plants are similar to ready mixed concrete production facilities with only additional steps for forming, and curing of the concrete mix.

Precast concrete facilities produce a variety of precast products, such as walls, floors, roofs, columns, beams etc. The production procedures differ by product. The forms used are usually made of steel, concrete, wood or fiberglass. Main steps in precast concrete making are i) mixing the raw materials ii) placing the concrete to the desired forms iii) consolidating by vibration, leveling and surface finishing iv) curing, and finally v) form stripping (U.S. EPA, 2004). When reinforcement is required, bars of steel are set in the forms before the placement of concrete. Steel reinforcements can also be tensioned prior concrete curing (pretensioning) or after (post-tensioning). The outcome is prestressed concrete. The developed compressive strengths create a product which is able to bear higher loads and can have bigger spans than conventional concrete (PCA, 2011b).

In precast concrete manufacturing, process control plays a significant role as curing is crucial for product quality. Curing time, humidity and temperature levels are closely monitored.

<sup>5</sup> The 2009 energy expenses for the manufacture of concrete blocks and bricks, as reported in the U.S. Census, included the energy expenditures for the manufacture of concrete pipes. Therefore the 2007 data is presented.

In 2007<sup>6</sup>, according to the U.S. Census Bureau (2009), the pipe and other concrete product manufacturing precast/prestressed industry spent over \$200 million on energy. Of this, 48% was spent on fuel and 52% on electricity.

There are variations in the type and the amount of energy used in precast concrete plants across the U.S. The most energy intensive step is curing, accounting for nearly 44% of the energy consumed (Table 5). The predominant fuel used for curing, according to the PCA survey (Marceau et al., 2007), is natural gas. Light trucks operating on-site are responsible for 32% of the overall energy consumed at the plant site, mainly diesel oil. Electricity use throughout the plant is around 17% of overall energy consumption.

**Table 5. Energy use in the U.S. precast concrete plants**

Energy Types	kBtu/ton concrete					kBtu/yd <sup>3</sup> concrete				
	precast (Precast Mix 3,000 psi)					precast (Precast Mix 3,000 psi)				
	light trucks	industrial boiler	building heat	various equipment	throughout plant	light trucks	industrial boiler	building heat	various equipment	throughout plant
<b>Gasoline</b>	12.0	0.0	0.0	0.0	12.0	23.5	0.0	0.0	0.0	23.5
<b>Liquefied petroleum gas</b>	0.0	19.3	0.0	2.1	21.4	0.0	37.8	0.0	4.2	42.0
<b>Fuel oil</b>	51.8	3.3	0.0	0.0	55.1	101.3	6.5	0.0	0.0	107.8
<b>Diesel</b>	34.3	0.0	0.0	0.0	34.3	67.1	0.0	0.0	0.0	67.1
<b>Kerosene</b>	0.0	0.0	0.3	0.0	0.3	0.0	0.0	0.5	0.0	0.5
<b>Electricity</b>	n/a	n/a	n/a	n/a	50.8 (15 kWh)	n/a	n/a	n/a	n/a	99.4 (29 kWh)
<b>Natural gas</b>	0.0	110.2	19.4	0.0	129.6	0.0	215.5	38.0	0.0	253.5
<b>Total</b>	98.1	132.8	19.7	2.1	303.5	191.9	259.7	38.6	4.2	593.7

Note: Energy Intensity is presented for a 3,000 psi Concrete Mix, as it is the one most commonly produced (around 90% market share). Concrete with strength ranging between 4,000 and 4,500 psi has a market share of 8%, while higher strength concrete only 1-2%. To change from 1 kBtu/yd<sup>3</sup> of concrete to 1 kBtu/ton of concrete divide with 1.96.

Source: Marceau et al., 2007

<sup>6</sup> The 2009 energy expenditures reported in the U.S. Census (2009), for the manufacture of precast concrete products, did not include the manufacture of concrete pipes (energy expenditures for the manufacture of concrete pipes was reported along with the manufacture of concrete bricks and blocks). Therefore, the 2007 is presented.

## 4 General Practices for Managing Your Energy Use

Concrete producers should make energy management a priority, and take action by implementing an organization-wide energy management program. It's one of the most successful and cost-effective ways to save energy. The ENERGY STAR program offers a variety of tools and resources to assist companies in developing strategic energy management approaches.

### ENERGY STAR® Energy Management Resources

The U.S. Environmental Protection Agency's (EPA) ENERGY STAR® [Guidelines for Energy Management](#) provide a management structure for organizations to follow in developing a strategy for achieving sustained performance.

Another ENERGY STAR guide, [Teaming Up to Save Energy](#), outlines how to form an energy team. By establishing a program, forming an energy team, increasing employee awareness, monitoring progress, and incorporating feedback into the process, companies can reduce their energy use and emissions, and potentially save money.

### 4.1 Effective Principles for Energy Savings

Companies that apply a few basic principles to energy management achieve greater savings. These principles can be applied by any company, regardless of size, that is serious about reducing energy use:

- **Make it a priority**  
Saving energy starts by making energy management a priority. Everyone in the company must recognize that reducing energy use is an important business objective and incorporate it into their decision making.
- **Commit to energy savings**  
Every level of the organization, from senior management on down, must commit to continuous energy efficiency improvement.
- **Assign responsibility**  
If you want to save energy, designate someone to be responsible for achieving a savings goal. Initially, this might be a designated "energy champion," but over time the responsibility can be expanded across the company. An energy team is a practical way to share the responsibility with roles assigned to each member of the team.
- **Look beyond first cost**  
With energy efficiency, you get what you pay for. It is critical to recognize that energy efficient equipment and products may cost the company more initially but that the lasting savings gained from their use will save more money over time.

- **Make energy management a continuous process**

Successful energy management involves more than just installing a few energy-efficient technologies. It involves establishing a committed company-wide program to manage energy continuously as a function of your business. It's an ongoing process that involves:

- understanding your energy use,
- setting goals,
- implementing good operational and maintenance practices,
- making behavioral changes,
- tracking and benchmarking energy use, and
- involving every employee.

ENERGY STAR works with leading industrial manufacturers to identify the basic aspects of effective energy management programs.<sup>7</sup> Figure 5 depicts the major steps.

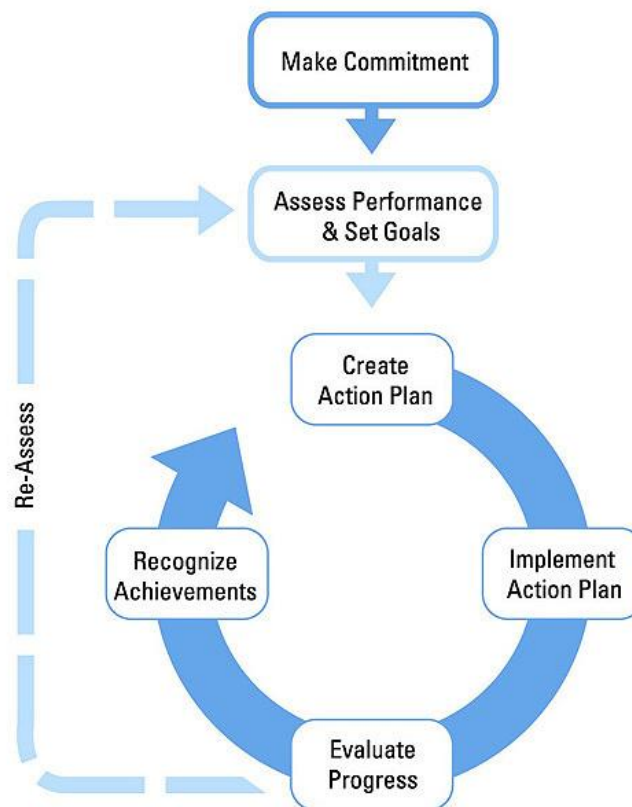

**Figure 5. Elements of strategic energy management, ENERGY STAR Guidelines for Energy Management**

Throughout the process, personnel at all levels should be aware of energy use and efficiency goals. Staff should be trained in both skills and general approaches to energy efficiency in day-to-day practices (examples of simple tasks employees can do are outlined in Appendix B). In

<sup>7</sup> Read more about strategic energy management at [ENERGY STAR for Industry \(www.energystar.gov/industry\)](http://www.energystar.gov/industry).

addition, regularly evaluate and communicate performance results to all personnel, and reward and recognize high achievements. Evaluating action plan progress requires a regular review of both energy use data and the activities carried out as part of the plan. A quick assessment of an organization's efforts to manage energy can be made by comparing its current energy management program against the [ENERGY STAR Energy Program Assessment Matrix](#) provided in Appendix A.

Four key elements contribute to the process of energy management: energy audits/assessments, energy teams, employee awareness, and energy monitoring. Technical aspects will be discussed in Sections 5 and 6.

## **4.2 Plant Energy Assessments**

Plant energy assessments determine where and how much energy is consumed and identify steps to improve the facility's energy efficiency. Use this Energy Guide to inform the scope and focus of an assessment in a concrete plant. Whether the assessment focuses on a whole site or on specific systems or processes, opportunities to save significant amounts of energy and money will be identified.

Assessments can be conducted by company staff, the local electric utility, contractors, or government programs.

- **Staff teams**

If company staff perform the plant assessment, it is effective to team up staff from various departments across the facility or company. The combined team approach brings together rich experience and knowledge on the plant and processes used. Such efforts can be successfully replicated at all sizes of facilities. The U.S. Department of Energy (U.S. DOE) also offers various tools to help with assessments (see Appendix C).

- **Electric utility program**

Local utility companies work with their industrial clients to achieve energy savings in both existing facilities and in the design of new facilities. Check with your local electric utility to see what assistance they can provide. Sometimes, utilities offer specific programs for improving plant systems such as lighting or motors.

- **Federal government programs**

The U.S. DOE supports plant assessments through the [Industrial Assessment Center \(IAC\)](#) program. IAC's (see Assessment and Technical Assistance in Appendix C) are designed to help small- and medium-sized enterprises. Universities participate in the program and offer free assessments, performed by students and university staff, to local companies.

### 4.3 Energy Teams

Establishing an energy team solidifies a company's commitment to improve energy efficiency.<sup>8</sup> The team is responsible for planning, implementing, benchmarking, monitoring, and evaluating the organization's energy management program. However, duties can also include delivering training, communicating results, and providing employee recognition (U.S. EPA, 2006).

#### *Forming the team*

When forming an energy team:

- establish the structure,
- name team members, and
- specify roles and responsibilities.

Senior management needs to value energy management as part of the organization's core business, so ideally the energy team leader will be someone at the corporate level who is empowered with support from senior-level management. The team should include members from each key energy-using process within the company. Ensure adequate funding, preferably as a line item in the normal budget cycle, as opposed to a special project.

#### **Any size company can create an energy team**

Team size and time commitment depends on the size and resources of the facility, its energy use, and the complexity of the key energy-consuming processes. Generally, in large facilities this will be a more substantial effort than in small facilities, where the team is likely to be a part-time effort of a few staff members.

Prior to the energy team's launch, hold a series of team strategy meetings to consider key goals, as well as potential pilot projects whose savings could be showcased at the program's kickoff. This Energy Guide should be consulted for project ideas as it identifies energy efficiency options in concrete production. Another important ENERGY STAR tool is the [facility assessment matrix](#) (see Appendix A) which can help the team identify missing energy management practices in the plant. The team should then perform a facility energy assessment (see above) to identify opportunities for energy efficiency improvements. As part of the facility assessment, the energy team should also look for best practices in action to help highlight successful strategies.

#### *Tracking and communicating results*

A key energy team function is to track and communicate progress, and to transfer knowledge gained through the assessments across an organization. Successful energy teams use best practice databases, facility benchmarking tools, intranet sites, performance tracking scorecards, and case studies of successful projects to help manage information.

A best practices database may be as simple as documenting energy saving best practices and case studies of successful projects identified by the team. It is important to have them accessible to all energy, plant, and shift managers. This can be done through a dedicated intranet site for the company or through other communication tools.

---

<sup>8</sup> For a comprehensive overview on how to establish, operate, and sustain an effective energy management team, consult the U.S. EPA's *Teaming Up to Save Energy* guide available at [Assess Your Energy Management Program : ENERGY STAR](#) (U.S. EPA 2006).



Benchmarking is a tool to compare the (energy) performance over time and between peer facilities in a consistent manner. Benchmarking can be very helpful to track performance of a plant and to identify opportunities for improvement (e.g. as energy intensity increases in a given period, or is higher than that of facilities with a similar mix of products). The ENERGY STAR program offers various [industrial benchmarking tools](#)<sup>9</sup>.

To sustain the savings and build momentum for continuous energy improvement, results and lessons learned must be communicated regularly to managers and employees, and a recognition and rewards program should be established.

Appendix D provides a checklist of key steps for forming, operating, and sustaining an effective energy management team.

#### **4.4 Employee Awareness**

Energy management involves more than just changing out old, inefficient equipment. It involves changing a company's culture as well. Employees must be trained in how to follow new processes or operate new energy-efficient equipment.

##### **Educated, empowered employees identify and achieve energy savings**

Engage employees and operators in energy assessments, projects, and the program—especially in day-to-day decisions. An effective energy awareness campaign:

- educates employees and operators about how their work practices affect the company, energy use, costs, and the environment,
- informs employees on how they can manage energy in their day-to-day responsibilities, and
- reminds employees about the company's energy goals.

To implement an effective energy awareness campaign, you must raise the level of:

- employee energy awareness,
- behavioral change, and
- active employee involvement.

Identify your audience and message to help you design a targeted awareness program. Periodically, review and evaluate the awareness campaign to ensure it is generating the desired results and refresh it frequently.

A wide array of activities can be included in an awareness campaign. ENERGY STAR has encountered a number of successful corporate approaches, including placement of stickers at light switches (Kodak), distribution of energy efficient lightbulbs to personnel (ArcelorMittal), handing out leaflets on home energy savings (Toyota), hosting energy training sessions for employees and giving access to home audit measurement devices (Titan America). Additional

<sup>9</sup> see: <http://www.energystar.gov/index.cfm?c=industry.industrybenchmarkingtools>

ideas include hanging posters in conspicuous locations and having information stands at employee events or in employee break rooms.

***Assistance with employee awareness programs.***

Many organizations run large energy awareness campaigns, often in collaboration with the U.S. Environmental Protection Agency's ENERGY STAR program or the Federal Energy Management Program (FEMP). These programs offer advice on how to run an energy efficiency campaign and provide materials (such as posters) that can be tailored to your company. See the following websites for examples:

- [Federal Energy Management Program](#)
- [The ENERGY STAR Challenge: Communication Materials](#)

## **4.5 Energy Monitoring Systems**

Sustaining energy savings over time requires continuous energy management. You cannot manage what you do not measure. Every company needs to compile, track, and benchmark energy data. Reliable energy data helps a company manage energy and interpret energy efficiency trends in operations over time.

Data on energy use can be found in utility bills, fuel purchase receipts, or from self-installed meters. Ideally, individual departments or processes should be sub-metered. Good energy data systems alert the energy team to problem areas. When changes in energy use occur, opportunities for corrective action and improvement can be identified by the energy team immediately.

Reading self-installed or utility-owned meters daily or weekly enables collection of more frequently data than is possible with utility billing data. This increased frequency improves the ability to quickly address changes in energy use and intensity. Sub-metering different production departments provides improved metrics but also enables quick pinpointing of areas where energy problems may occur. An added bonus is that installed meters supply the information needed to calculate energy and cost savings from implemented energy management activities.

Except for installation of sub-meters, an energy monitoring system requires little or no upfront capital and may result in immediate savings. Energy monitoring systems incorporate sub-meters at key places in a plant where energy may be strategically managed. Management of data from the meters is best handled by a data management tool; a simple spreadsheet may be sufficient. If the budget can support it, tailored software is also available, and can help better identify problems and savings.

In its simplest form, an energy monitoring system should be based on the following:

- Monthly utility billing and energy use data for the past 12 to 24 months
- Monthly production figures

Using a simple spreadsheet, both can be plotted in various graphs to understand the relationship between energy use and production, and to identify any trends:

- Graph of energy use and production in a single graph over time
- Graph of energy costs and production in a single graph over time

- Graph of energy use on vertical axis against production on horizontal axis
- Graph of energy use divided by production (showing specific energy consumption)

Tools offered within commonly used spreadsheet packages can help to identify relationships and quantify trends. Graphs can be made for fuel and electricity separately, as well as for total energy use (showing both in the same units, such as megajoules or British thermal units) and costs.

Often the analysis will show periods of good performance and subpar performance—information that can help you set targets for energy consumption based on expected production volumes. Tracking energy use by entering new data and evaluating it as regularly as the data allows will help you to identify problems and improve energy savings.

Energy monitoring can also provide useful data for corporate greenhouse gas accounting initiatives. Successful monitoring programs regularly report energy use (sometimes daily) to identify increasing energy use and costs that could be caused by operational inefficiencies. Energy monitoring and metering systems can also help companies participate in emergency demand response programs, in which utility companies provide financial incentives to customers who reduce their energy loads during peak demand times.

## 5 Energy Efficiency Opportunities for Common Plant Systems

Energy efficiency is often the lowest risk investment a company can make in its plants. Energy efficiency projects nearly always deliver sure savings. According to Titan America, energy audits conducted in concrete plants have revealed that low to no cost improvements can reduce energy costs by more than 20% (Bayne, 2011). Further, energy savings contribute directly to the company's bottom line by improving operating costs. As energy costs are forecast to increase over time, energy efficiency is a surefire method of reducing risk to a company.

Use Section 5 of this report to identify opportunities to control energy use in common plant systems. Common plant systems are those that are found in most manufacturing plants in the U.S. regardless of the industry. Many of the energy efficiency measures discussed in this section require either a limited investment or none at all.

Energy efficiency measures are described below by different end-use categories. Generally, each section begins with the easier-to-implement measures. For each measure typical savings are identified as are payback periods. Case studies of companies that implemented successful measures are included to highlight potential savings. Table 8 lists energy efficiency measures according to the system to which they apply.

### 5.1 Building Lighting

Lighting contributes significantly to electrical energy consumption, and savings can be substantial. Lighting provides overall ambient light throughout manufacturing, storage, and office spaces and provides low-bay and task illumination in specific areas. Lighting demand is measured by a quantity of lumen of visible light needed at a certain point of time. The quantity of electricity (in watts) needed to supply the demand for lighting (in lumen) is expressed as the *efficacy* of the light source (in lumen/watt). The maximum theoretical efficiency is 700 Lumen/Watt. The term *luminaire* refers to the hardware, and *lamp* refers to the bulb. Another important parameter is the *color rendering index (CRI)*. The CRI is a measure of a light source's ability to show colors "naturally" compared to a familiar reference source, e.g. daylight. More information about factors to consider when choosing appropriate lighting is offered through the [Lighting Research Center](http://www.lrc.rpi.edu/) at Rensselaer Polytechnic Institute.<sup>10</sup>

Generally, high-intensity discharge (HID) sources—including metal halide, high-pressure sodium, and mercury vapor lamps—are used for manufacturing and storage areas. Fluorescent, compact fluorescent (CFL), and incandescent lights are typically used for task lighting and offices. Lighting controls should be used in all areas of the plant.

Only a small part of the energy used in a lighting fixture results in lighting; the remainder is lost as heat. So, even when lighting is a relatively small part of a plant's energy use, it may be possible to find considerable energy savings from

#### Did You Know?

Only a small part of the energy used in a lighting fixture results in lighting; the remainder is lost as heat. Considerable energy savings can be found in more energy-efficient lighting.

<sup>10</sup> See: <http://www.lrc.rpi.edu/>

using more efficient lighting systems. For specific applications, such as lighting in refrigerated or air conditioned spaces, increasing lighting efficiency (and therefore reducing heat) may result in other savings. Next to energy use, the lifetime of a lamp is important because a long lamp life also reduces maintenance costs.

Table 6 provides an overview of the typical performance and applications of various lamp types.

**Table 6. Performance comparison of lighting sources**

Lamp	Efficacy (Lumen/watt)	Typical Lifetime (Hours)	Applications
Incandescent	5–20	1,000	Task
Halogen	<24	1,000	Task
CFL	20–70	8,000–15,000	Task
Fluorescent T-12	60	20,000	Any
Fluorescent T-8	80–100	20,000	Any
Fluorescent T-5	80–105	20,000	Any
Mercury Vapor	30-50	60,000	Hi-Bay
Induction	80	100,000	Exterior, Hi-Bay
High Pressure Sodium	85–150	10,000–50,000	Exterior, Hi-Bay
Metal Halide	70–115	20,000	Hi-Bay
LED	10–120	50,000	Task

Note: Values are typical performance. Performance of individual products may vary. The performance of fluorescent lamps assumes the use of an electronic ballast. Technology development may change the future performance of specific lighting technologies.

The ENERGY STAR program suggests cost-effective ways to save on lighting energy. Measures to improve lighting efficiency include simple measures such as switching off the lights to replacing lights and fixtures to installing innovative lighting systems. Check with your local electric utility to see what programs and incentives they may offer to help improve lighting performance.

**Turn off lights in unoccupied areas.** Encourage personnel to turn off lights in unoccupied building spaces. An awareness program will help staff get in the habit of switching off lights and other equipment when not in use. Often, lights are on in areas (such as warehouses or parts of production areas) at times when they are not needed, and occupancy controls may help to reduce energy waste (see Lighting Controls below).

**Establish lighting level standards.** For both new facilities and retrofits, lighting levels (expressed as lumen per surface area) should be set in the design of each section of a plant and followed in ordering, manufacturing, and installation. Work with both manufacturers and suppliers to ensure that the proper system is installed.

Lighting standards can be set for different work areas. For example, Toyota set different lighting standards for quality check areas, warehouses, and office buildings. By setting a lumen/surface area standard and sticking to it, Toyota claims savings of 30% on lighting energy use. Moreover, lighting levels were reduced in areas that need lighting only for safety (such as automated warehouses and robot-operated process areas). Similarly, use of sections in a plant may change over time (for example, from assembly to storage), resulting in overlit areas. Conduct plant

energy assessments with this point in mind. Ford Motor Company reduced energy costs for lighting by eliminating some lights in overlit areas.

### Use lighting controls

*Automatic controls.* Lights should be shut off during non-working hours through automatic controls. Occupancy sensors turn off lights when a space is unoccupied. Occupancy sensors can save 10% to 20% of a facility’s lighting energy use. Numerous case studies suggest an average payback period of one year. Daylight controls for indoor and outdoor lights can adjust lighting intensity based on the availability of daylight.

*Manual controls.* Manual controls can be used in conjunction with automatic controls to save additional energy in smaller areas. One of the easiest measures is to install switches to allow occupants to control lights. If automatic controls are not possible, some companies have found success in developing and enforcing a “lights out” program where specific employees are tasked with turning lights off at appropriate times.

**Case Study: Controls + Low Energy Light Bulbs**

Marley Eternit, a precast concrete facility, aimed to reduce electricity consumption by 10% per ton of product. With the introduction of sensors, and by replacing conventional light bulbs with low energy light bulbs, the company achieved annual energy savings of \$9,000 (British Precast, 2008). The investment cost was \$6,500. The lighting hours were reduced by 50%, while the light bulb lifetime increased from 8,000 hours to above 20,000 hours.

*Lighting controls in practice.* An example of an energy-efficient lighting control is illustrated in Figure 6, which depicts five rows of overhead lights in a workspace. During the brightest part of the day, ample daylight for most of the room is provided by the window, so only row C would need to be lit. At times when daylight levels drop, all B rows would be lit and row C would be turned off. Only at night or on very dark days would it be necessary to have both rows A and B lit. These methods can also be used as a control strategy on a retrofit by adapting the luminaires already present.

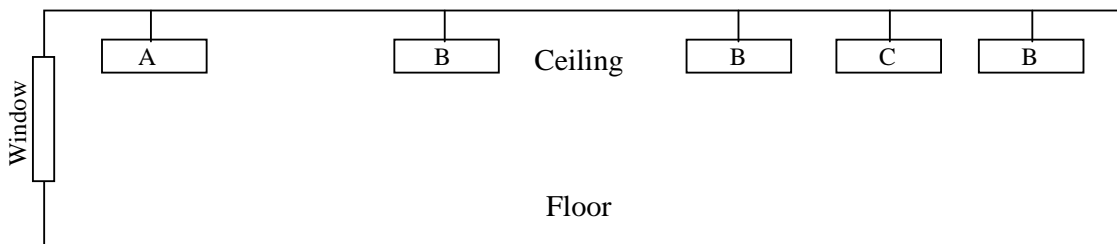

**Figure 6. Lighting placement and controls**

**Use daylighting.** *Daylighting* involves the efficient use of natural light in buildings to minimize the need for artificial lighting. Increasing levels of daylight within rooms can reduce electrical lighting loads by up to 70%. Unlike conventional skylights, an efficient daylighting system may provide evenly dispersed light without creating heat gains, reducing the need for cooling

compared to skylights. Daylighting is applied primarily to new buildings and incorporated at the design stage. However, existing buildings can sometimes be cost-effectively refitted with these systems.

Daylighting technologies include properly placed and shaded windows, atria, clerestories, light shelves, and light ducts—all of which can accommodate various angles of the sun and redirect daylight using walls or reflectors. Because daylighting is variable, it is almost always combined with artificial lighting to ensure the necessary illumination on cloudy days or after dark. Combining daylighting with lighting controls can maximize its benefits. More information can be found at the website of the [Daylighting Collaborative](#) led by the Energy Center of Wisconsin.

**Replace incandescent lamps with compact fluorescent lamps (CFL).** A fluorescent lamp lasts roughly ten times longer than an incandescent light and is significantly more energy efficient. The payback period for the replacement varies, but it can be as low as five months.

**Replace T-12 tubes with T-8 tubes.** T-12 lighting tubes are the long fluorescents 12/8 inches in diameter (the “T” designation refers to a tube’s diameter in terms of 1/8 inch increments). Many industrial facilities still use these tubes. T-12 tubes consume significant amounts of electricity, and also have poor efficacy, lamp life, lumen depreciation, and color rendering index. As a result, T-12 maintenance and energy costs are high. T-8 lighting tubes have about twice the efficacy of T-12 tubes and can last up to 60% longer, which leads to reduced maintenance cost savings. Typical energy savings from the replacement of a T-12 lamp by a T-8 lamp are about 30%.

**Replace mercury lamps.** Where color rendition is critical, metal halide lamps can replace mercury or fluorescent lamps with energy savings of up to 50%. Where color rendition is not critical, high-pressure sodium lamps offer energy savings of 50% to 60% compared to mercury lamps.

**Reduce high-intensity discharge (HID) voltage.** Reducing lighting system voltage can also save energy. Commercially available voltage controllers can easily be fitted to a central panel switch and constrict the flow of electricity to lighting fixtures, thereby reducing voltage and saving energy, with an imperceptible loss of light. A Toyota production facility installed reduced-voltage HID lights and reduced lighting energy consumption by 30%. Voltage controllers work with both HID and fluorescent lighting systems and are available from multiple vendors.

**Consider replacing HID lighting with high-intensity fluorescent lights.** Traditional HID lighting can be replaced with T-5 high-intensity fluorescent lighting systems, which incorporate high-efficiency fluorescent lamps, electronic ballasts, and high-efficacy fixtures that maximize output to work areas. These systems can often have lower energy consumption, lower lumen depreciation over the lifetime of the lamp, better dimming options, faster startup and re-strike capabilities, better color rendition, higher pupil lumen ratings, and improved glare performance than traditional HID systems. The payback period is typically below three years, but it can be as low as a few months, since several electrical utility companies (i.e. Dominion) offer rebates to replace inefficient lighting (Dominion, n.d.).

**Replace magnetic ballasts with electronic ballasts.** A ballast regulates the amount of electricity required to start a lighting fixture and maintain steady light output. Electronic ballasts can require 12% to 30% less power than their magnetic predecessors. New electronic ballasts have smooth and silent dimming capabilities, in addition to longer lives (up to 50% longer), faster run-up times, and cooler operation than magnetic ballasts. New electronic ballasts also have automatic switch-off capabilities for faulty or end-of-life lamps.

**Use energy-efficient exit signs.** Energy costs can be reduced by switching from incandescent lamps to Light Emitting Diodes (LEDs) or radium strips in exit sign lighting. An incandescent exit sign uses about 40 watts (W), while LED signs may use only about 4 W to 8 W, reducing electricity use by 80% to 90%. A 1998 Lighting Research Center survey found that about 80% of exit signs being sold use LEDs. The lifetime of an LED exit sign is about 10 years, compared to one year for incandescent signs, which reduces maintenance costs considerably.

New LED exit signs are inexpensive, with prices typically starting at about \$20. In addition to exit signs, LEDs are increasingly being used for path marking and emergency way finding systems. The U.S. EPA's ENERGY STAR program website ([www.energystar.gov](http://www.energystar.gov)) lists LED exit sign suppliers.

Tritium exit signs are an alternative to LED versions. Tritium signs are self-luminous, so they do not require an external power supply. Their advertised lifetime is about 10 years, and prices typically start at about \$150 per sign.

**LED lighting.** Light Emitting Diode (LED) lights have been receiving a lot of attention as the next generation of energy efficient lighting. In typical florescent lighting, electrical arcs are used to excite mercury and phosphorous compounds, which then emit light. On the other hand, LED lights are semiconductor diodes that use far less energy to emit the same lumens of light. Several new LED light products are emerging on the market, that are compatible with current light fixtures, such as T-8 light fixtures (Myer and Paget, 2009).

### Case Study: LED Lighting

According to Titan America, the installation of 10 LED fixtures instead of HID fixtures on a beltline resulted in higher than initially anticipated savings in electricity costs, of about \$50 per fixture per year. HID fixtures needed more time to switch on therefore, they had to remain on during the night for the employees to check the equipment. With the installation of LED fixtures that are characterized by "instant on" and the use of light switch timers the lights now burn only 250 hours instead of 4,000 hours per year. The cost of LED fixtures was \$200 higher than HID fixtures. (Bayne, 2011)

## 5.2 Building HVAC

*HVAC* stands for heating, ventilation, and air conditioning and refers to the equipment, distribution network, and terminals used either collectively or individually to provide fresh filtered air, heating, cooling, and humidity control in a building. The main goals of HVAC are to provide comfort and indoor air quality, which depend on many factors, such as thermal regulation, control of internal and external sources of pollutants, supply of acceptable air, removal of unacceptable air, occupant's activities and preferences, and proper operation and maintenance of building systems (ASHRAE, 2005).



Air exchange between outdoor and indoor air is needed to maintain good air quality and agreeable indoor temperatures. Two processes—ventilation and infiltration—affect this exchange. *Ventilation* is intentional use of air to provide acceptable indoor air, either through natural movement (such as windows and doors) or mechanical means, by using fans or vents. *Infiltration* is the flow of outdoor air into a building through cracks and other unintentional openings, and should be minimized.

Air and water are heated by means of a boiler, furnace, or heat pump, and they are distributed evenly through ducts for air or pipes and radiators for water. Air cooling is performed by cooling coils (based on refrigeration cycles) or evaporation (when the incoming air humidity is low). Many combinations of heating and cooling sources supply the HVAC system. With heating, for example, a gas- or oil-fired boiler or furnace, heat pump, rooftop unit, new technology (such as infrared radiation), or electric heat could be employed. For cooling, common sources include rooftop units, chillers, heat pumps, air conditioners, or off-peak cooling systems.

**Employ an energy-efficient system design.** For HVAC systems in new industrial facilities, the greatest opportunities for energy efficiency arise at the design stage. Sizing equipment properly and designing energy efficiency into a new facility generally minimizes the energy consumption and operational costs of HVAC systems from the outset. This practice often saves money in the long run, as it is generally cheaper to install energy-efficient HVAC equipment during construction than it is to upgrade an existing building with an energy-efficient system later on, especially if those upgrades lead to downtime.

**Commission and recommission.** Before replacing HVAC system components to improve energy efficiency, explore the possibility of HVAC system recommissioning. Recommissioning is essentially the same process as commissioning, but it is applied to a building's existing HVAC, controls, and electrical systems (U.S. EPA, 2008).

*Commissioning* is the process of verifying that a new building functions as intended and communicating the intended performance to the building management team. This usually occurs when a new building is turned over for occupancy. In practice, commissioning costs are not included in design fees and often compete with other activities, so commissioning is seldom pursued properly. To ensure that energy performance and operational goals are met, however, the building must be commissioned. To achieve this, ENERGY STAR recommends the following:

- Communicate your energy performance goals during commissioning to ensure that the design target is met. Encourage energy-use tracking so that performance comparisons are made over time.
- Specify detailed commissioning activities in project contracts. Seek separate funding for commissioning work, to ensure that it will get done and be done well.
- Hire building commissioning experts. Include the commissioning firm as part of the design team early in the project.
- Finalize and transfer a set of technical documents, including manufacturers' literature for systems and components. Supplement technical literature with summaries of how to operate and manage the systems. Provide additional explanation for innovative design features.

*Recommissioning* involves a detailed assessment of existing equipment performance and maintenance procedures. This is compared to the intended or design performance and maintenance procedures in order to identify and fix problem areas that might be hampering building energy efficiency. Recommissioning can be a cost-effective retrofit in itself, sometimes generating more savings than the cost of the retrofit measure. For example, recommissioning may help avoid the need to install new or additional equipment, leading to savings in capital investments.

The U.S. EPA's ENERGY STAR Building Upgrade Manual (U.S. EPA, 2008) recommends a stepwise approach to recommissioning, in which a series of strategically-ordered building "tune up" strategies are pursued. First, lighting and supplemental loads should be assessed, then the building envelope, then controls, then testing, adjusting and balancing, then heat exchange equipment, and finally heating and cooling systems. Most of these steps relate to HVAC system components or factors that will directly affect HVAC system energy consumption (such as building envelope and lighting). For more information, consult the manual.

**Install energy monitoring and control systems.** An energy monitoring and control system supports the efficient operation of HVAC systems by monitoring, controlling, and tracking system energy consumption. Such systems continuously manage and optimize HVAC system energy consumption while also providing building engineers and energy managers with a valuable diagnostic tool for tracking energy consumption and identifying potential HVAC problems. Several projects indicate that the average payback period for HVAC control systems is about 1.3 years.

**Adjust non-production hours set-back temperatures.** Setting back building temperatures (that is, adjusting building temperatures down in the winter or up in the summer) during periods of non-use, such as weekends or non-production times, can significantly reduce HVAC energy consumption.

**Repair leaking ducts.** Leaking air ducts can waste significant amounts of energy. Install duct insulation and perform regular duct inspection and maintenance, including ongoing leak detection and repair. According to a study by Lawrence Berkeley National Laboratory, repairing duct leaks in industrial and commercial spaces can reduce HVAC energy consumption by up to 30%. The study also showed that duct tape should not be used for leak repair; aerosol sealants are preferred.

**Consider variable-air-volume systems.** Variable-air-volume systems adjust the rate of air flow into a room or space based on the current air flow requirements of that room or space. Variable-air-volume systems therefore work to more closely match HVAC load to heating and cooling demands, which reduces energy use.

**Install adjustable-speed drives (ASDs).** Adjustable speed drives can be installed on variable-volume air handlers and recirculation fans to match precisely the flow and pressure requirements of air handling systems. Energy consumed by fans can be lowered considerably since they do not

constantly run at full speed. Adjustable-speed drives can also be used on chiller pumps and water systems pumps to minimize power consumption based on system demand.

**Consider heat recovery systems.** Heat recovery systems reduce the energy required to heat or cool facility intake air by recovering the thermal energy of the exhaust air. Common heat recovery systems include heat recovery wheels, heat pipes, and run-around loops. Heat pipes recover about 45% to 65% of the exhaust heat, while the efficiency of run-around loops can be in the 55% to 65% range.

**Modify your fans.** Changing the size or shape of the sheaves of a fan can help to optimize fan efficiency and airflow, reducing energy consumption. Toyota optimized the sheaves of its fans instead of installing adjustable-speed drives (ASDs) on fans, finding better savings and payback periods than expected.

**Use ventilation fans.** Ventilation fans installed in the ceilings of work areas can help destratify workspace air, leading to better circulation of cool air in summer and warm air in winter, as well as more even temperature distributions from floor to ceiling. Such fans can help reduce the load on building heating systems by helping to “push down” warm air that rises during heating months.

**Install efficient exhaust fans.** Exhaust fans are standard components in any HVAC system. Mixed flow impeller exhaust fans offer an efficient alternative to traditional centrifugal exhaust fans. They are typically 25% more efficient than centrifugal fans and can be cheaper to install and maintain. The expected payback period is about two years (Tetley, 2001).

**Add building insulation.** Adding insulation will reduce utility bills. Older buildings are likely to use more energy than newer ones, leading to very high heating and air conditioning bills. However, even in new buildings, adding insulation may reduce utility bills enough to pay for itself within a few years.

Various states have regulations and guidelines for building insulation—for example, California’s [Energy Efficiency Standards for Residential and Nonresidential Buildings \(Title 24\)](#). Going beyond regulated insulation levels may be economically beneficial and should be considered as part of a new building’s design, as well as for reconstruction of existing buildings. For refrigerated warehouses, much higher levels of insulation are preferred.

**Employ solar air heating.** Solar air heating systems, such as Solarwall<sup>®</sup>, use conventional steel siding painted black to absorb solar radiation for insulation. Fresh air enters the bottom of the panels where it is heated as it passes over the warm absorber, and fans distribute the air. Using this technology, the Ford Motor Company’s Chicago Stamping Plant turned its south wall into a huge solar collector (CREST, 2001). Energy savings were estimated to be over \$300,000 per year compared to conventional natural gas air systems. Capital costs were \$863,000 (about \$15 per square foot, including installation), resulting in a payback period of less than three years. In addition to energy savings, the system was said to provide clean fresh air for employees. This measure is best applied at buildings in cold climates, and the potential benefits should be analyzed based on each site’s local conditions.

### **Modify building reflection**

*Reflective roofing.* Use of a reflective coating on the roof of buildings in sunny, hot climates can save on air conditioning costs inside. Using reflective roofs, two medical offices in Northern California reduced air conditioning demand; one by 8% and the other by 12%. For colder climates, the heat lost due to cool roofs (in winter, for example) needs to be considered, as it could negate savings. In addition to location and weather, other primary factors (such as roof insulation, air conditioning efficiency, and building age) also influence energy savings. Reflective roof materials are available in different forms and colors.

*“Green” roofs.* Roof gardens on a flat roof improve the insulation of buildings against both hot and cold by providing both heat (in winter) and air conditioning (in summer). In winter, “green” roofs can freeze, so they carry a slight heating penalty but often still yield net energy savings. In addition, a roof garden can increase the lifetime of the roof, reduce runoff, and reduce air pollution and dust. The Gap Headquarters in San Bruno, California, installed roof gardens in 1997. In addition to saving energy and lasting longer than traditional roofs, a roof garden absorbs rain, slowing run-off to local storm drains.

*Shading and windbreaks.* Shade trees reduce the need for cooling in hot climates. Shade trees should be deciduous (providing shade in the summer and none in the winter) and planted on the west and southwest sides of the building (based on the path of the summer sun). Trees planted on the north side of the building in cold climates can reduce heating in winter by shielding the building from the wind. Vines can provide both shade and wind shielding.

**Install low-emittance (Low-E) windows.** Low-emittance windows are another effective strategy for improving building insulation. Low emittance windows can lower the heat transmitted into a building to increase its insulating ability. There are two types of Low-E glass: high solar transmitting (for regions with higher winter utility bills) and low solar transmitting (for regions with higher summer utility bills). The U.S. DOE supports the development of new window and glazing technology, and the ENERGY STAR website includes a selection of rated Low-E windows. New window and glazing technology is being developed worldwide (see for example [www.efficientwindows.org](http://www.efficientwindows.org)).

### **5.3 Motors**

Motors are the main industrial electricity consumer and are used in many plant systems, such as HVAC, compressed air, refrigeration and cooling, and various processes. This section applies to any system that uses motors. Examples are used to detail specific applications and their success.

When considering energy efficiency improvements to a facility’s motor systems, take a “systems approach.” Rather than considering the energy efficiency of just the motor, the systems approach strives to optimize the energy efficiency of the entire motor system (including the motor; driven equipment such as pumps, fans, and compressors; and

#### **Did You Know?**

Up to 95% of a motor’s costs can be attributed to the energy it consumes over its lifetime, while only about 5% of a motor’s costs are typically attributed to its purchase, installation, and maintenance (MDM, 2007).

controls). A systems approach analyzes both the energy supply and energy demand sides of motor systems, as well as how both sides interact to optimize total system performance. The focus is on both energy use and system uptime and productivity.

A systems approach for motors typically involves the following five steps:

1. Locate and identify all motors in the facility.
2. Document conditions and specifications of each motor to provide a current systems inventory.
3. Assess the needs and the actual use of the motor systems to determine whether or not motors are properly sized and how well each motor meets the needs of its driven equipment.
4. Collect information on potential repairs and upgrades to the motor systems, including the economic costs and benefits of implementing repairs and upgrades, to enable the energy efficiency improvement decision-making process.
5. If upgrades are pursued, monitor the performance of the upgraded motor systems to determine actual costs savings.

#### Case Study: Efficient Motors

At CEMEX (formerly RMC Pacific Materials), 13 worn, inefficient and wrong types of motors, used in cement blowers and silo pumps, were replaced by new ones. By using the DOE's MotorMaster+software tool, plant personnel was able to identify the causes of inefficiency (U.S. DOE, 2005). The motor replacement with more efficient and of the right type motors yielded 2 million kWh energy savings and \$168,000. The annual savings in maintenance costs were \$30,000.

The motor system energy efficiency measures below reflect important aspects of this approach, including matching motor speeds and loads, proper motor sizing, and upgrading system components.

**Develop a motor management plan.** A motor management plan is an essential part of a plant's energy management strategy. It helps support long-term motor system energy savings and ensure that motor failures are handled quickly and cost effectively. The National Electrical Manufacturers Association (NEMA) and other organizations have created the Motor Decisions Matter<sup>SM</sup> campaign to help industrial and commercial customers evaluate their motor repair and replacement options, promote cost-effective applications of NEMA Premium<sup>®</sup> motors and "best practice" repair, and support the development of motor management plans before motors fail. The national campaign suggests the following actions for a sound motor management plan (MDM, 2007):

1. Create a motor survey and tracking program.
2. Develop guidelines for proactive repair/replace decisions.
3. Prepare for motor failure by creating a spares inventory.
4. Develop a purchasing specification.
5. Develop a repair specification.
6. Develop and implement a predictive and preventive maintenance program.

The Motor Decisions Matter Campaign's [\*Motor Planning Kit\*](#) contains further details on each of these elements (MDM, 2007).

**Select motors strategically.** Important factors to consider when selecting a motor include speed, horsepower, enclosure type, temperature rating, efficiency level, and quality of power supply. When selecting and purchasing a motor, consider the motor's life-cycle costs rather than just its initial purchase and installation costs. Up to 95% of a motor's costs can be attributed to the energy it consumes over its lifetime, while only about 5% of a motor's lifetime costs are attributed to its purchase, installation, and maintenance (MDM, 2007). Life cycle costing (LCC) is an accounting framework that enables users to calculate total ownership costs of different investment options, leading to a sound evaluation of competing motor purchasing, repair, or replacement alternatives. A specific LCC guide developed for pump systems (Fenning et al., 2001) provides a general introduction to LCC for motor systems.

*Motor efficiency.* Selecting energy-efficient motors is an important strategy for reducing motor system life-cycle costs because they reduce energy losses through improved design, better materials, tighter tolerances, and improved manufacturing techniques. With proper installation, energy-efficient motors can also run cooler (which may help reduce facility heating loads) and have higher service factors, longer bearing life, longer insulation life, and less vibration.

To be considered energy-efficient in the United States, a motor must meet NEMA performance criteria. The Consortium for Energy Efficiency (CEE) has described the evolution of standards for energy-efficient motors in the United States, which is helpful for understanding the "efficient" motor nomenclature (CEE, 2007):

- NEMA energy-efficient motor standard (NEMA EE) was developed in the mid-1980s (NEMA, 2002), and in 1992 the Energy Policy Act (EPACT) required that many motors comply with NEMA "energy-efficient" ratings if sold in the United States.
- A CEE Premium Efficiency Criteria specification was designed in 1996 to promote motors with higher efficiency levels than EPACT required.
- In 2001, the NEMA Premium Efficiency Electric Motor specification was developed to address confusion with respect to what constituted the most efficient motors available in the market. This specification was developed by NEMA, CEE, and other stakeholders, and was adapted from the CEE 1996 criteria. It currently serves as the benchmark for premium energy-efficient motors. NEMA Premium<sup>®</sup> also denotes a brand name for motors which meet this specification. Specifically, this specification covers motors with the following attributes:
  - Speed: 2-, 4-, and 6-pole
  - Size: 1 to 500 horsepower (hp)
  - Design: NEMA A and B
  - Enclosure type: open and closed
  - Voltage: low and medium voltage
  - Class: general, definite, and special-purpose

The choice of whether or not to install a premium efficiency motor strongly depends on (1) motor operating conditions, and (2) the life cycle costs associated with the investment. In general, premium efficiency motors are most economically attractive when replacing motors with an annual operation exceeding 2,000 hours/year. Software tools such as MotorMaster+ (see Tools for Self-Assessment in Appendix C) can help identify attractive applications of premium efficiency motors based on specific plant conditions. Given the quick payback time, it usually makes sense to buy the most efficient motor available.

Sometimes, replacing an operating motor with a premium efficiency model may have a short payback period. According to data from the Copper Development Association, the upgrade to high-efficiency motors, as compared to motors that achieve the minimum efficiency as specified by EPACT, can have paybacks of less than 15 months for 50 hp motors. Payback times will vary based on size, load factor, running time, local energy costs, and available rebates and/or incentives.

*Rewind versus replace.* In some cases, it may be cost-effective to rewind an existing energy-efficient motor instead of purchasing a new one. As a rule of thumb, when rewinding costs exceed 60% of the costs of a new motor, purchasing the new motor is a better choice (MDM, 2007). If you do decide to rewind, choose a motor service center that follows best-practice motor rewinding standards in order to minimize potential efficiency losses. An ANSI-approved recommended best-practice standard has been offered by the Electric Apparatus Service Association (EASA) for the repair and rewinding of motors (EASA, 2006). When best rewinding practices are implemented, efficiency losses are typically less than 0.5% to 1% (EASA, 2003). However, poor quality rewinds may result in larger efficiency losses, so it is important to ask whether the motor service center follows EASA best practice standards (EASA, 2006).

#### Did You Know?

As a rule of thumb, when rewinding costs exceed 60% of the costs of a new motor, purchasing the new motor is a better choice (MDM, 2007).

**Maintain your motors.** Motor maintenance helps you prolong motor life and foresee potential failures. Maintenance measures can be categorized as either preventative or predictive. The purpose of *preventative* measures is to prevent unexpected downtime. These measures include voltage imbalance minimization, load consideration, motor ventilation, alignment, and lubrication. The purpose of *predictive* motor maintenance is to observe ongoing motor temperature, vibration, and other operating data to determine when it will become necessary to overhaul or replace a motor before failure occurs. Savings from an ongoing motor maintenance program can range from 2% to 30% of total motor system energy use.

**Ensure that motors are properly sized.** Inappropriately sized motors result in unnecessary energy losses. If peak loads on driven equipment can be reduced, so can motor size. Replacing oversized motors with properly sized motors saves U.S. industry, on average, 1.2% of total motor system electricity consumption. Higher savings can often be realized for smaller motors and individual motor systems.

To determine the proper motor size, gather the following data: load on the motor, operating efficiency of the motor at that load point, the full-load speed of the motor to be replaced, and the full-load speed of the replacement motor. The U.S. DOE's BestPractices program provides [fact sheets](#) that can help you to decide whether to replace oversized and under-loaded motors. Additionally, software packages such as MotorMaster+ (see Tools for Self-Assessment Appendix C) help in proper motor selection.

**Motor Automation.** Motors should only run when needed. A 10% reduction in motor operating time can save more energy than replacing a conventional motor with a NEMA Premium<sup>®</sup>

efficiency motor (U.S. DOE, 2008). Automatic shutdown of motors that would otherwise be left idling can reduce energy costs without requiring high investment. According to plant assessments from Titan America, a 25 hp non-automated motor running unloaded for 5 hours per day, costs about \$1,000 annually (Bayne, 2011).

Although there is a concern that increasing motor start-ups will negatively affect the motor's lifetime, the lifetime will not be significantly affected as long as the frequency of motor start-ups is not excessive (U.S. DOE, 2008). NEMA (2001) gives the maximum number of allowable motor start-ups per hour and the duration of rest time between start-ups, for various horsepower motors and synchronous speed ratings.

**Consider adjustable speed drives (ASDs).** It is common practice in the ready mixed concrete industry to keep the mixer idling at full load all the time, even when there are no trucks to be loaded, to ensure that concrete does not set in the drum. In this case, the application for adjustable frequency drives (ASDs) could result in significant energy savings.

Adjustable-speed drives better match speed to load requirements for motor operations, and therefore ensure that motor energy use is optimized to a given application. These systems are offered by many suppliers worldwide. Energy savings may vary from 7% to as high as 60%, depending on the use pattern of the motor. Computer controls can be used with ASDs to control the adjustment of power to match demand.

**Case Study: ASDs**

Blue Circle's Bowmanville plant (Canada) replaced the inlet fan damper used in the coal mill, with a variable inlet fan (CIPEC, 2001a). The annual electricity and fuel cost savings were CAN\$75,000 (approximately \$47,000 in U.S. dollars).

**Correct power factor.** Inductive loads like transformers, electric motors, and HID lighting may cause a low power factor, resulting in increased power consumption and electricity costs. The power factor can be corrected by minimizing idling of electric motors (a motor that is turned off consumes no energy), replacing motors with premium-efficient motors (see above), and installing capacitors in the AC circuit to reduce the magnitude of reactive power in the system.

**Minimize voltage unbalances.** A voltage unbalance degrades the performance and shortens the life of three-phase motors. It also causes a current unbalance, which will result in torque pulsations, increased vibration and mechanical stress, increased losses, and motor overheating (which can reduce the life of the motor's winding insulation).

Voltage unbalances may be caused by faulty operation of power factor correction equipment, an unbalanced transformer bank, or an open circuit. A rule of thumb is that the voltage unbalance at the motor terminals should not exceed 1%. Even a 1% unbalance will reduce motor efficiency at part load operation, while a 2.5% unbalance will reduce motor efficiency at full load operation. For a 100 hp motor operating 8,000 hours per year, a correction of the voltage unbalance from 2.5% to 1% will result in electricity savings of 9,500 kWh, or almost \$500 at an electricity rate of \$0.05/kWh.



Voltage unbalances may be identified by regularly monitoring the voltages at the motor terminal and through regular thermographic inspections of motors. Verify that single-phase loads are uniformly distributed and install ground fault indicators as required. Another indicator that a voltage unbalance may be a problem is 120 Hz vibration; which should prompt an immediate check of voltage balance. The typical payback period for voltage controller installation on lightly loaded motors in the United States is 2.6 years.

This section has focused on motors and motor systems in general. The following two sections address more specifically on the energy efficiency opportunities in the two key motor systems: compressed air (Section 5.4) and pumps (Section 5.5). Industrial refrigeration systems are another important user of motors (for compressors). For a more detailed description of energy efficiency opportunities in refrigeration systems, please consult Masanet et al. (2008).

## 5.4 Compressed Air

Compressed air is the most expensive form of energy used in an industrial plant because of its poor efficiency, typically about 10% from start to end use. If compressed air is used, it should be at the minimum quantity for the shortest possible time, and it should be constantly monitored and reweighed against alternatives. Many energy-reduction opportunities in compressed air systems are not prohibitively expensive, and payback periods for some are extremely short, often less than one year.

### Compressor Facts

- Air receivers can be employed near high-demand areas to provide a supply buffer to meet short-term demand spikes that can exceed normal compressor capacity. In this way, required online compressors may be reduced.
- Multiple-stage compressors theoretically operate more efficiently than single-stage compressors. Replacing single stage compressors with two-stage compressors typically provides a payback period of 2 years or less.
- Many multi-stage compressors save energy by cooling the air between stages, reducing the volume and work required to compress the air.
- Using multiple smaller compressors instead of one large compressor can save energy as well.
- Large compressors consume more electricity when they are unloaded than do multiple smaller compressors with similar overall capacity.
- An analysis of case studies around the country shows an average payback period of about 1.2 years.

**Maintain compressed air systems.** Inadequate maintenance can lower compression efficiency and increase air leakage or pressure variability, and can lead to increased operating temperatures, poor moisture control, and excessive contamination of compressed air system components. Better maintenance will reduce these problems and save energy.

The following bullets summarize compressed air problems and maintenance solutions:

- *Blocked pipeline filters increase pressure drop.* Keep the compressor and intercooling surfaces clean and foul-free by inspecting and periodically cleaning filters. Seek filters with just a 1 pound per square inch (psi) pressure drop. The payback period for filter cleaning is usually under two years. Fixing improperly operating filters will also prevent

contaminants from entering into tools, which causes them to wear out prematurely. Generally, when pressure drop exceeds 2 to 3 psig, replace the particulate and lubricant removal elements. Inspect all elements at least annually. Also, consider adding filters in parallel to decrease pressure drop. Expect a 2% reduction of annual energy consumption in compressed air systems when filters are changed frequently.

- *Poor motor cooling* can increase motor temperature and winding resistance, shortening motor life and increasing energy consumption. Keep motors and compressors properly lubricated and cleaned. Sample and analyze compressor lubricant every 1000 hours and ensure that it is at the proper level. In addition to energy savings, this maintenance can help avoid system corrosion and degradation.
- *Inspect fans and water pumps* regularly to ensure proper performance.
- *Inspect drain traps* periodically to ensure they are not stuck in either the open or closed position and are clean. Some users leave automatic condensate traps partially open at all times to allow for constant draining; however, this practice wastes substantial amounts of energy and should never be implemented. Instead, install simple pressure-driven valves. Clean and repair malfunctioning traps instead of leaving them open. Some automatic drains or valves do not waste air, such as those that open when condensate is present. According to vendors, inspecting and maintaining drains typically has a payback period of less than two years.
- *Maintain the coolers* on the compressor and the aftercooler to ensure that the dryer gets the lowest possible inlet temperature.
- If using compressors with belts, *check the belts* for wear and adjust them. A good rule of thumb is to adjust them every 400 hours of operation.
- *Check water cooling systems* for water quality (pH and total dissolved solids), flow, and temperature. Clean and replace filters and heat exchangers as suggested by the manufacturer.
- *Minimize leaks* (see also Leaks section, below).
- *Specify pressure regulators* that close when failing.
- Applications requiring compressed air should be *checked for excessive pressure, duration, or volume*. They should be regulated, either by production line sectioning or by pressure regulators on the equipment itself. Tools not required to operate at maximum system pressure should use a quality pressure regulator, since poor quality regulators tend to drift and lose more air. Otherwise, the unregulated tools operate at maximum system pressure at all times and waste excess energy. System pressures operating too high also result in shorter tool life and higher maintenance costs.

Monitor compressed air use. As with maintenance, proper monitoring of compressed air systems can save energy and money. Proper monitoring includes the following:

- Pressure gauges on each receiver or main branch line, and differential gauges across dryers and filters. Temperature gauges across the compressor and its cooling system to detect fouling and blockages.
- Flow meters to measure the quantity of air used.
- Dew point temperature gauges to monitor air dryer effectiveness.
- Kilowatt-hour meters and hours-run meters on the compressor drive.

**Reduce leaks in pipes and equipment.** Air leaks can be a significant source of wasted energy. A typical plant that has not been well maintained could have a leak rate between 20% to 50% of total compressed air production capacity. Leak repair and maintenance can reduce this number to less than 10%. Overall, fixing leaks in a compressed air system is projected to reduce annual energy consumption by 20%.

The magnitude of a leak varies with the size of the hole in the pipes or equipment. It is estimated that losses based on a compressor operating 2,500 hours per year at 6 bar (87 psi) will experience the following losses:

- With a leak diameter of 0.02 inches (½ millimeter [mm]): 250 kWh/year
- With a leak diameter of 0.04 in. (1 mm): 1,100 kWh/year
- With a leak diameter of 0.08 in. (2 mm): 4,500 kWh/year
- With a leak diameter of 0.16 in. (4 mm): 11,250 kWh/year

The most common areas for leaks are couplings, hoses, tubes, fittings, pressure regulators, open condensate traps and shut-off valves, pipe joints, disconnects, and thread sealants. Quick-connect fittings always leak and should be avoided. Leaks can make air tools less efficient and adversely affect production, shorten the life of equipment, lead to additional maintenance requirements, and increase unscheduled downtime. Leaks also cause an increase in compressor energy and maintenance costs. However, it is cost-effective to fix leaks, with typical repairs costing \$400. In more than one thousand examples of reducing leaks in pipes and equipment, the average payback period was about five months.

**Case Study: Leak Repair**

After encountering problems with keeping up with product demand while the plant was operating at full capacity, Marshalls Landscape Products, in Falkirk (UK), conducted an investigation which revealed a big leak in the compressor system. With the use of a sonic leak detector, the leak was identified and repaired. The facility's annual energy savings were \$7,000. (British Precast, 2008)

*Detecting leaks.* A simple way to detect large leaks is to apply soapy water to suspect areas, or to use a bag to monitor the velocity of the air filling the bag, although this may be time consuming. In the “bag test,” a plastic bag is put up to the leak and used to monitor the velocity of the air filling the bag.

Another simple way to identify leaks is by performing a bleed down test (Bayne, 2011). In order to conduct the test, the plant air system is brought to full pressure and then shut down. By recording the system pressure while compressed air is not used anywhere in the plant, any pressure losses can be attributed to existing leaks.

**Case Study: Leak Repair**

Roanoke Cement, after conducting an ultrasonic leak audit in a concrete facility, revealed 7 leaks. The annual cost of the leaks was \$740.

The best way to detect leaks is to use an ultrasonic acoustic detector, which can recognize the high-frequency hissing sounds associated with air leaks. After identifying them, leaks should be tracked, repaired, and verified. Leak detection and correction programs should be ongoing efforts.

**Turn off unnecessary compressed air.** Equipment that is no longer using compressed air should have the air turned off completely. This can be done using a simple solenoid valve. Check compressed air distribution systems when equipment has been reconfigured to ensure no air is flowing to unused equipment or obsolete parts of the compressed air distribution system.

**Modify the system instead of increasing system pressure.** For individual applications that require a higher pressure, consider special equipment modifications instead of raising the operating pressure of the whole system. For example:

- use a booster,
- increase a cylinder bore,
- change gear ratios, and
- change operation to off -peak hours.

**Use sources other than compressed air.** Many operations can be accomplished more economically and efficiently using other energy sources. Some industry engineers believe this measure has the largest potential for compressed air energy savings. As shown in Table 7, various options can replace compressed air use. In a California Portland owned ready mixed concrete facility, the replacement of a pneumatic valve used in the water system for truck cleaning with an electric one resulted in the shutdown of compressors earlier in the day (Coppinger, 2011).

**Case Study: Use Sources Other than Compressors**

A plant was using compressors to generate vacuum for use in its wet presses. The annual electricity cost was \$15,000. After investing in liquid ring pump systems, the annual electricity cost dropped to \$5,500. (British Precast, 2008)

**Table 7. Alternatives for compressed air**

Application	Alternative
Cooling electrical cabinets	Air conditioning fans should be used instead of using compressed air vortex tubes.
Flowing high pressure air past an orifice to create a vacuum	A vacuum pump system should be applied instead of compressed air venturi methods.
Cooling, aspirating, agitating, mixing, or package inflating	Blowers
Cleaning parts or removing debris	Brushes, blowers, or vacuum pump systems or nozzles that are more efficient
Moving parts	Blowers, electric actuators, or hydraulics
Blowguns, air lances, and agitation	Low-pressure air or mechanical actions
Tools or actuators	Consider efficient electric motors. Some sources, however, have reported that motors can have less precision, shorter lives, and lack safety. In these cases, using compressed air may be a better choice.

Note : Numerous case studies across industry estimate an average payback period of 11 months for replacing compressed air with other applications.

**Manage the load.** Because of the large amount of energy consumed by compressors, whether in full operation or not, partial load operation should be avoided. Centrifugal compressors are cost effective when operated at high loads.

**Use air at lowest possible pressure.** Although system pressure may be higher, air used for a particular application should be at the lowest pressure needed. For compressed air systems in the range of 100 psig, having 30-50% unregulated air (leaks, open blowing etc.), a 2 psi decrease in pressure will result in 1.6-2.0% energy savings (U.S. DOE and CAC, 2003).

#### **Case Study: Use Air at Lowest Possible Pressure**

In a Titan America concrete facility, reducing the compressed air system pressure by 10 psi resulted in 6.5% energy savings (Bayne, 2011). This was a zero cost savings measure.

**Minimize pressure drop in distribution system design.**

An excessive pressure drop results in poor system performance and excessive energy consumption. Flow restrictions of any type, such as an obstruction or roughness, require operating pressures to be higher than necessary. Flow resistance increases pressure (and associated compressor energy use) by 1% for each 2 psi of pressure rise. The highest pressure drops are usually found at the points of use. These include:

- undersized or leaking hoses
- tubes
- disconnects
- filters
- regulators
- valves
- nozzles and lubricators (demand side)
- air/lubricant separators on lubricated rotary compressors and aftercoolers
- moisture separators
- dryers, and
- filters.

Minimizing pressure drop requires a systems approach in design and maintenance. Select air treatment components with the lowest possible pressure drop at the specified maximum operating conditions and best performance. Follow manufacturers' recommendations for maintenance, particularly for air filtering and drying equipment, which can have damaging moisture effects like pipe corrosion. Finally, minimize the distance that air travels through the distribution system.

#### **Case Study: Compressors**

Lehigh Cement Company, in its Techacapi, California cement plant, implemented a system-level project and improved the operation of the compressed air system. The project stabilized the pressure levels, replaced worn compressors, and reduced compressed air waste. After the advancements took place, the compressor system is more efficient, has lower capacity and operates under lower pressures (U.S. DOE, 2003). The savings in electricity were \$90,000 while the savings in maintenance costs were \$59,000. Additional cost savings of \$50,000 were accomplished as the rental of emergency compressors was eliminated. The investment was \$417,000 and the payback period was less than 20 months.

**Reduce inlet air temperature.** If air flow is kept constant, reducing the inlet air temperature reduces energy used by the compressor. In many plants, it is possible to reduce inlet air temperature to the compressor by taking suction from outside the building. As a rule of thumb, each 5°F (3°C) will save 1% compressor energy. A payback period may be between one to five years.

**Controls.** The total air requirement is the sum of the average air consumption for each tool on the system, so a control strategy should focus on shutting off unneeded tools. This can mean shutting off compressors or not turning on additional compressors until needed. All compressors that are on should be running at full load, except for one, which should handle trim duty.

To determine proper control systems, assess compressed air requirements over time, establishing a load profile. When demand is less than peak, the most efficient strategy is to use multiple smaller compressors with sequencing controls. Facilities with a flat load profile can use simpler control strategies.

Control loop positioning is also important; reducing and controlling the system pressure downstream of the primary receiver can reduce energy consumption up to 10% to 12%. Various control types exist:

- *Start/stop* (on/off) is the simplest control strategy and can be applied to small reciprocating or rotary screw compressors. Start/stop controls turn the motor driving the compressor on or off in response to the machine's discharge pressure. These controls are used for applications with very low duty cycles. Applications with frequent cycling will cause the motor to overheat. Typical payback period for start/stop controls is one to two years.
- *Load/unload control*, or *constant speed control*, allows the motor to run continuously but unloads the compressor when the discharge pressure is adequate. In most cases, unloaded rotary screw compressors still consume 15% to 35% of full-load power when fully unloaded, while delivering no useful work. Therefore, load/unload controls can be inefficient and require ample primary receiver volume.
- *Modulating or throttling controls* allow the output of a compressor to be varied to meet flow requirements by closing down the inlet valve and restricting inlet air to the compressor. Throttling controls are applied to centrifugal and rotary screw compressors. Changing the compressor control to a variable speed control can save up to 8% of electricity and electricity cost per year.
- *Multi-step or part-load controls* can operate in two or more partially loaded conditions. Output pressures can be closely controlled without requiring the compressor to start/stop or load/unload.
- *System controls* work on multiple compressors. Single master sequencing system controls take individual compressor capacities on and offline in response to monitored system pressure demand and shut down any compressors running unnecessarily. System controls for multiple compressors typically offer a higher efficiency than individual compressor controls.

**Properly size regulators.** Regulators can provide the largest energy savings in compressed air systems. By properly sizing regulators, compressed air that is otherwise wasted as excess air will be saved. Specify pressure regulators that close when failing.

**Size pipe diameter correctly.** Inadequate pipe sizing can cause pressure losses, increase leaks, and increase generating costs. Pipes must be sized correctly for optimal performance or resized

to fit the current compressor system. Increasing pipe diameter typically reduces annual energy consumption by 3%.

**Implement system improvements.** Adding additional compressors should be considered only after a complete system evaluation. Implementing some of the measures discussed in this section can reduce air demand considerably, negating the need to purchase additional compressors. The [Compressed Air Challenge®](#) offers free web-based guidance for selecting the right integrated service provider, as well as guidelines defining walk-through evaluations, system assessments, and fully instrumented system audits.

**Recover heat for water preheating.** As much as 80% to 93% of the electrical energy used by an industrial air compressor is converted into heat. In many cases, a heat recovery unit can recover 50% to 90% of the available thermal energy for the following applications:

- Space heating
- Industrial process heating
- Water heating
- Makeup air heating
- Boiler makeup water preheating
- Industrial drying

Payback periods are typically less than one year. It is estimated that approximately 50 kBtu/hour of energy is available for each 100 cubic foot per minute of capacity (at full load). Note that heat recovery for space heating is not as common with water-cooled compressors because an extra stage of heat exchange is required and the temperature of the available heat is lower.

## 5.5 Pumps

Pumps are particularly important pieces of motor-driven equipment in many small- and medium-sized plants. They are used extensively to pressurize and transport water in cleaning, water fluming, and wastewater handling operations; for transporting liquid streams between processes; and for circulating liquids within processes. The basic components in a pump system are pumps, drive motors, piping networks, valves, and system controls. Some of the most significant energy efficiency measures applicable to these components and to pump systems as a whole are described below.

### Did You Know?

As much as 20% of the energy consumed by pumping systems could be saved through changes to pumping equipment and/or pump control systems.

Take a systems approach when assessing pump energy efficiency improvement opportunities within a facility. Even if an individual pump is operating efficiently, if it is generating more flow than the system requires for a given application, it is wasting energy and money. Assess both individual pump efficiencies and how well the various pump system end uses are being served by its pumps.

A pump's initial capital cost is typically only a small fraction of its total life cycle costs. In general, maintenance and energy costs represent by far the most significant fraction of a pump's total life cycle costs. In some cases, energy costs can account for up to 90% of the total cost of owning a pump. So, when choosing pumping equipment, base your decision on projected energy and maintenance costs rather than on initial capital costs alone.

The Pump Systems Matter™ program ([www.pumpsystemsmatter.org/](http://www.pumpsystemsmatter.org/)), conceived by the Hydraulic Institute, provides detailed information on improving the performance of pump systems. The most important opportunities for increasing efficiency are discussed below.

**Implement a pump system maintenance program.** Inadequate maintenance can lower pump system efficiency, cause pumps to wear out more quickly, and increase pumping energy costs. Implementing a pump system maintenance program will help you avoid these problems by keeping pumps running optimally. Improved pump system maintenance can lead to pump system energy savings from 2% to 7%.

A solid pump system maintenance program will generally include the following tasks (U.S. DOE, 2006a):

- Place worn impellers, especially in caustic or semi-solid applications.
- Inspect and repair bearings.
- Replace bearing lubrication annually or semiannually.
- Inspect and replace packing seals. Allowable leakage from packing seals is usually between 2 to 60 drops per minute.
- Inspect and replace mechanical seals. Allowable leakage is typically 1 to 4 drops per minute.
- Replace wear ring and impeller. Pump efficiency degrades by 1% to 6% for impellers less than the maximum diameter and with increased wear ring clearances.
- Check pump/motor alignment.
- Inspect motor condition, including the motor winding insulation.

**Monitor pump systems.** Monitoring, combined with a proper maintenance program, will help detect pump system problems before they escalate into major performance issues or equipment repairs. Monitoring can be done manually on a periodic basis (for example, performing regular bearing oil analyses to detect bearing wear, or using infrared scanning to detect excessive pump heat), or it can be performed continuously using sensor networks and data analysis software (such as using accelerometers to detect abnormal system vibrations) (U.S. DOE, 2006a). Monitoring can help keep pump systems running efficiently by detecting system blockages, impeller damage, inadequate suction, clogged or gas-filled pumps or pipes, pump wear, and if pump clearances need to be adjusted.

In general, a good pump monitoring program should include the following aspects:

- Wear monitoring.
- Vibration analysis.
- Pressure and flow monitoring.
- Current or power monitoring.



- Monitoring of differential head and temperature rise across pumps (also known as thermodynamic monitoring).
- Distribution system inspection for scaling or contaminant build-up.

**Reduce pump demand.** An important component of the systems approach is to minimize pump demand by better matching pump requirements to end-use loads. Two effective strategies for reducing pump demand are (1) the use of holding tanks, and (2) the elimination of bypass loops.

Holding tanks can be used to equalize pump flows over a production cycle, which can allow for more efficient operation of pumps at reduced speeds and lead to energy savings of up to 10% to 20%. Holding tanks can also reduce the need to add pump capacity.

The elimination of bypass loops and other unnecessary flows can produce similar energy savings, as can lowering process static pressures, minimizing elevation rises in the piping system, and lowering spray nozzle velocities.

**Install controls.** Control systems can increase the energy efficiency of a pump system by shutting off pumps automatically when demand is reduced or by putting pumps on standby at reduced loads until demand increases.

**Install high efficiency pumps.** It has been estimated that up to 16% of pumps in use in U.S. industry are more than 20 years old. Considering that a pump's efficiency may degrade by 10% to 25% over the course of its life, replacement of aging pumps can lead to significant energy savings. The installation of newer, higher efficiency pumps typically leads to pump system energy savings of 2% to 10%.

A number of high efficiency pumps are available for specific pressure head and flow rate capacity requirements. Choosing the right pump saves both operating costs and capital costs. For a given duty, selecting a pump that runs at the highest speed suitable for the application will generally result in a more efficient selection, as well as the lowest initial cost (U.S. DOE, 2001).

**Properly size pumps.** Pumps that are oversized for an application consume more energy than necessary. Replacing oversized pumps with properly sized ones can reduce pumping system electricity use by 15% to 25%. Where peak loads can be reduced through improvements to pump system design or operation (for example, through the use of holding tanks), pump size can also be reduced. If a pump is dramatically oversized, often its speed can be reduced with gear or belt drives, or with a slower-speed motor. The typical payback period for these strategies can be less than one year.

**Use multiple pumps for variable loads.** The use of multiple pumps installed in parallel can be a cost-effective and energy-efficient solution for pump systems with variable loads. Parallel pumps offer redundancy and increased reliability, and can often reduce pump system electricity use by 10% to 50% for highly variable loads. Parallel pump arrangements often consist of a large pump, which operates during periods of peak demand, and a small (or "pony") pump, which operates under normal, more steady-state conditions (U.S. DOE, 2006a). Because the pony pump is sized

for normal system operation, this configuration operates more efficiently than a system that relies on a large pump to handle loads far below its optimum capacity.

**Consider trimming impellers.** *Impeller trimming* is machining to reduce an impeller's diameter. This reduces the energy added by the pump to the system fluid. According to the U.S. DOE (2006a), one should consider trimming an impeller when any of these conditions occur:

- Many system bypass valves are open, indicating that excess flow is available to system equipment.
- Excessive throttling is needed to control flow through the system or process.
- High levels of noise or vibration indicate excessive flow.
- A pump is operating far from its design point.

Trimming an impeller is slightly less effective than buying a smaller impeller from the pump manufacturer, but it can be useful when an impeller at the next available smaller size would be too small for the given pump load. The energy savings associated with impeller trimming are dependent upon pump power, system flow, and system head, but are roughly proportional to the cube of the diameter reduction (U.S. DOE, 2006a). An additional benefit of impeller trimming is a decrease in pump operating and maintenance costs.

**Avoid throttling valves.** Throttling valves and bypass loops are indications of oversized pumps. They also indicate the inability of the pump system design to accommodate load variations efficiently, so they should always be avoided. Pump demand reduction, controls, impeller trimming, and multiple pump strategies (all previously discussed) are preferred over throttling valves.

**Replace drive belts.** According to industrial pump inventory data, up to 4% of pumps are equipped with V-belt drives. Many of these V-belt drives can be replaced with direct couplings, which are estimated to lead to energy savings of about 1%.

**Properly size pipes.** Pipes that are too small for the required flow velocity can significantly increase the amount of energy required for pumping, in much the same way that drinking a beverage through a small straw requires a greater amount of suction. Where possible, pipe diameters can be increased to reduce pumping energy requirements, but the energy savings due to increased pipe diameters must be balanced with increased costs for piping system components. Increasing pipe diameters will likely only be cost effective during greater pump system retrofit projects. Typical energy savings are estimated at 5% to 20%.

**Consider adjustable-speed drives (ASDs).** Pumps that experience highly variable demand conditions are often good candidates for ASDs. As pump system demand changes, ASDs adjust the pump speed to meet this demand, thereby saving energy that would otherwise be lost to throttling or bypassing. The resulting energy and maintenance cost savings can often justify the investment costs for the ASD. However, ASDs are not practical for all pump system applications—for example, those that operate at high static head and those that operate for extended periods under low-flow conditions (U.S. DOE, 2006a).

## 5.6 Hot Water and Steam Systems

Hot water and steam is used for many industrial applications. In the concrete industry, boilers are used to heat batching water during cold weather, and heat the aggregates when needed. In the precast/prestressed industry significant amounts of steam are used to accelerate the curing process. The size and use of modern systems vary greatly; however, steam systems do follow a typical pattern, as illustrated in Figure 7. Treated cold feed water is fed to the boiler, where it is heated to form steam. Chemical treatment of the feed water removes many impurities that would otherwise collect on boiler walls, but some remain, so the water is periodically purged from the boiler in a process known as *blowdown*. The generated steam travels along distribution pipes to the process where the heat will be used. If the process requires lower pressure steam, the steam from the boiler may be passed through a pressure reduction valve before final use. As the steam is used to heat processes, and even as it travels through the distribution system to get there, the steam cools and some is condensed. This condensate is removed by a steam trap, which passes the condensate through but blocks passage of the steam. The condensate can be recirculated to the boiler, thus recovering some heat and reducing the need for fresh treated feed water. The recovery of condensate and blowdown also reduces the costs of boiler feed water treatment.

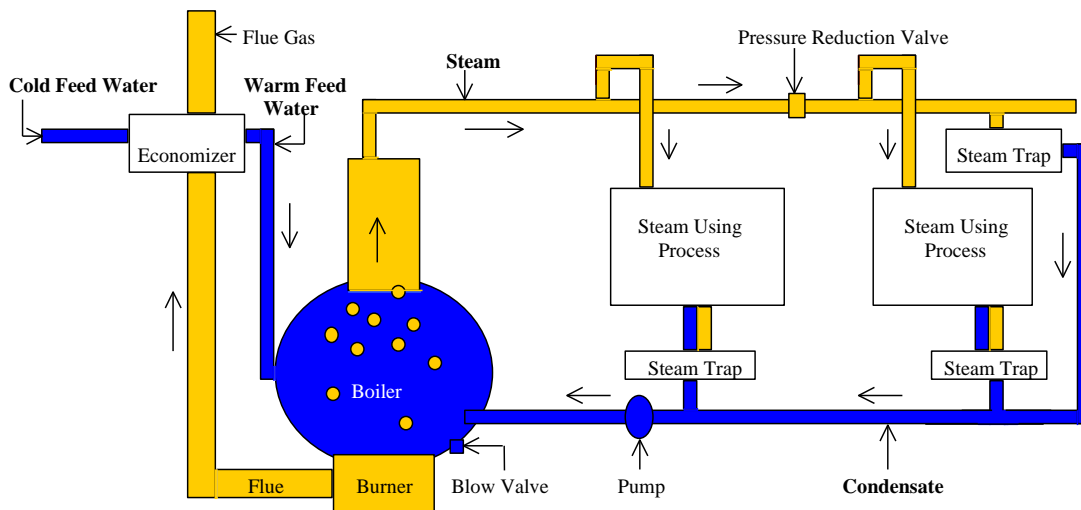

**Figure 7. Simplified schematic of a steam production and distribution system.**

The most important industrial applications for steam are:

- process heating,
- drying,
- concentrating,
- steam cracking,
- distillation, and
- driving machinery such as compressors.

Whatever the use or the source of the hot water or steam, efficiency improvements in steam generation, distribution, and end use are possible. According to the U.S. DOE, a typical

industrial steam system assessment can identify potential energy use and cost savings of 10% to 15% per year (U.S. DOE, 2006b).

Take a system approach in evaluating steam systems. First, identify where and how hot water and steam is used and then identify the efficiencies with which it is used, because often this can result in the largest savings.

Because steam, like any other secondary energy carrier, is expensive to produce and supply, its use should be carefully considered and evaluated against other options. Often steam is generated at higher pressures than needed or in larger volumes than needed at a particular time. These inefficiencies may lead steam systems to let down steam to a lower pressure or to vent it to the atmosphere. So evaluate the steam system on the use of appropriate pressure levels and production schedules.

If it is not possible to reduce the steam generation pressure, it may still be possible to recover the energy through a turbo expander or back-pressure steam turbine. Many systems may produce steam at higher pressures, to allow for the efficient cogeneration of power and heat through the use of back-pressure turbines. Excess steam generation can be reduced through improved process integration and improved management of steam flows in the industry.

The normal replacement investment cycle might offer opportunities to change to more energy-efficient steam systems.

### **5.6.1 Boiler energy efficiency measures**

The boiler energy efficiency measures presented below focus primarily on improved process control, reduced heat loss, and improved heat recovery. When new boiler systems are needed, they should be designed and installed in a custom configuration that meets a particular plant's needs. Pre-designed boilers often cannot be fine-tuned to meet the unique steam generation and distribution system requirements of a specific plant in the most efficient manner.

**Control boiler processes.** Flue gas monitors maintain optimum flame temperature and monitor carbon monoxide (CO), oxygen, and smoke. The oxygen content of the exhaust gas is a combination of excess air (which is deliberately introduced to improve safety or reduce emissions) and air infiltration. By combining an oxygen monitor with an intake airflow monitor, it is possible to detect even small levels of air infiltration.

A small 1% air infiltration will result in 20% higher oxygen readings. A higher CO or smoke content in the exhaust gas is a sign that there is insufficient air to complete fuel burning. Using a combination of CO and oxygen readings, it is possible to optimize the fuel/air mixture for high flame temperature (and thus the best energy efficiency) and lower air pollutant emissions.

Typically, this measure is financially attractive only for large boilers, because smaller boilers often will not make up the initial capital cost as easily. Case studies indicate that the average payback period for this measure is about 1.7 years.

**Reduce flue gas quantities using visual inspection.** Excessive flue gas can be released from leaks in the boiler and/or in the flue. These leaks can reduce the heat transferred to the steam and increase pumping requirements. However, such leaks are easily repaired, saving 2% to 5% of the energy formerly used by the boiler.

This measure differs from flue gas monitoring in that it consists of a periodic repair based on visual inspection. The savings from this measure and from flue gas monitoring are not cumulative, as they both address the same losses.

**Reduce excess air.** When too much excess air is used to burn fuel, energy is wasted, because excessive heat is transferred to the air rather than to the steam. Air slightly in excess of the ideal stoichiometric fuel-to-air ratio (that is, the amount of inlet air per unit of fuel combusted) is required for safety and to reduce nitrogen oxide (NO<sub>x</sub>) emissions, but approximately 15% excess air is generally adequate. Most industrial boilers already operate at 15% excess air or lower, and thus this measure may not be widely applicable (Zeitz, 1997). However, if a boiler is using too much excess air, numerous industrial case studies indicate that the payback period for this measure is less than 1 year.

**Properly size boiler systems.** Designing the boiler system to operate at the proper steam pressure can save energy by reducing stack temperature, piping radiation losses, and leaks in steam traps. In a Canadian study of 30 boiler plants, savings from this measure ranged from 3% to 8% of total boiler fuel consumption (Griffin, 2000). Costs and savings will depend heavily on the current boiler system utilization at individual plants.

#### Did You Know?

On average, the energy savings associated with improved boiler maintenance are estimated at 10%. Improved maintenance may also reduce the emission of criteria air pollutants.

**Improve boiler insulation.** It is possible to use new insulation materials, such as ceramic fibers, that both insulate better and have a lower heat capacity (thus allowing for more rapid heating). Savings of 6% to 26% can be achieved if improved insulation is combined with improved heater circuit controls. Due to the lower heat capacity of new insulating materials, the steam output temperature will vary more quickly with variations in the heating element temperature. Improved boiler process control is therefore often required in tandem with new insulation to maintain the desired output temperature range.

**Implement a boiler maintenance program.** A simple maintenance program ensures that all boiler components are operating at peak performance and can result in substantial savings. In the absence of a good maintenance system, burners and condensate return systems can wear or get out of adjustment. These factors can end up costing a steam system up to 30% of its initial efficiency over two to three years.

Control fouling on the fire side of boiler tubes and scaling on the water side of boilers. Fouling and scaling are more of a problem with coal-fed boilers than natural gas or oil-fed boilers. Boilers that burn solid fuels like coal should be checked more often because they have a higher fouling tendency than liquid fuel boilers do. Tests of various Canadian boilers show that a fire

side soot layer of 0.03 inches (0.8 mm) reduces heat transfer by 9.5%, while a 0.18 inch (4.5 mm) soot layer reduces heat transfer by 69% (CIPEC, 2001b). For water side scaling, 0.04 inches (1 mm) of buildup can increase fuel consumption by 2% (CIPEC, 2001b).

**Recover flue gas heat.** Heat recovery from flue gas is often the best opportunity for heat recovery in steam systems, as it can be used to preheat boiler feed water in an economizer. While this measure is fairly common in large boilers, there is still room for more heat recovery. The limiting factor is that the economizer wall temperature must not drop below the dew point of acids contained in the flue gas (such as sulfuric acid derived from sulfur-containing fossil fuels). Traditionally, this has been accomplished by keeping the flue gases exiting the economizer at a temperature significantly above the acid dew point. In fact, the economizer wall temperature is much more dependent on feed water temperature than on flue gas temperature because of the high heat transfer coefficient of water. As a result, it makes more sense to preheat feed water to close to the acid dew point before it enters the economizer. This approach allows the economizer to be designed so that exiting flue gas is just above the acid dew point. Typically, 1% of fuel use is saved for every 45°F (25°C) reduction in exhaust gas temperature.

**Return condensate to the boiler.** Reusing hot condensate in boilers saves energy, reduces the need for treated boiler feed water, and reclaims water at up to 100°C (212°F) of sensible heat.

Typically, fresh feed water must be treated to remove solids that might accumulate in the boiler; thus, returning condensate (which has already been treated) to a boiler can substantially reduce the amount of purchased chemical required to accomplish this treatment. This measure can save substantial energy costs and, purchased chemicals costs often makes building a return piping system attractive. Payback period will depend on the plant layout, but can vary between two and three years.

#### **Case Study: Return Condensate and Economizer**

Day & Campbell, a concrete block manufacturer, was discharging condensate water to the municipal sanitary sewage system. With the installation of a new reverse osmosis wastewater treatment system, condensate water is now treated and reused as pre-heated boiler feedwater. A boiler economizer was installed, which captures heat from flue gases to further elevate the feed water temperature. The projected natural gas savings were 258,000 yd<sup>3</sup> per year. The payback period, from savings in natural gas alone, was 2.5 years. Other cost savings derive from reduced process water disposal costs as these dropped by 70%; chemical costs used in process water treatment decreased by 25%. (Campbell, 2008)

**Recover blowdown steam.** When water is blown from a high-pressure boiler tank, the pressure reduction often produces substantial amounts of steam. This steam is typically low grade, but can be used for space heating and feed water preheating. The recovery of blowdown steam can save about 1% of boiler fuel use in small boilers. In addition to energy savings, blowdown steam recovery may reduce the potential for corrosion damage in steam system piping.

**Replace old boilers.** Substantial efficiency gains can often be achieved by replacing old boilers with new, higher-efficiency models. In particular, replacing inefficient coal-fired boilers with

natural gas-fired boilers is a sound strategy for reducing both boiler fuel costs and air pollutant emissions.

### 5.6.2 Steam distribution system energy efficiency measures

Steam and hot water distribution systems are often quite extensive and can be major sources of energy losses. Energy efficiency improvements to steam distribution systems primarily focus on reducing heat losses throughout the system and recovering useful heat from the system wherever feasible. The following measures are some of the most significant opportunities for saving energy in industrial steam distribution systems.

**Improve distribution system insulation.** Using more insulating material or using the best type of insulation material for the application can save energy in steam systems. Crucial factors in choosing insulating material include low thermal conductivity, dimensional stability under temperature change, resistance to water absorption, and resistance to combustion. Other characteristics of insulating material also may be important, depending on the application, such as tolerance of large temperature variations, tolerance of system vibrations, and adequate compressive strength where the insulation is load bearing. Industrial case studies indicate that the payback period for improved insulation is typically about one year.

#### Case Study: Blowdown Steam

The H+H Borough Green site in Kent (UK), after the installation of a heat recovery system, saves \$140,000 each year in energy costs. Waste steam that was previously blown down into a pit, is passed through a heat exchanger and is used to preheat boiler feedwater. (British Precast, 2008)

**Maintain distribution system insulation.** It is often found that after heat distribution systems have undergone some form of repair, the insulation is not replaced. In addition, some types of insulation can become brittle or rot over time. A regular inspection and maintenance system for insulation can save energy.

**Improve steam traps.** Modern thermostatic element steam traps can reduce energy use while improving reliability. The main efficiency advantages are that these traps:

- open when the temperature is very close to that of saturated steam (within 4°F or 2°C),
- purge non-condensable gases after each opening, and
- are open on startup to allow a fast steam system warm-up.

These traps also have the advantage of being highly reliable and useable for a range of steam pressures.

It is common to find 15% to 20% of steam traps malfunctioning.

**Maintain steam traps.** A simple program of checking steam traps to ensure that they are operating properly can save significant amounts of energy for very little money. In the absence of such a program, it is common to find 15% to 20% of steam traps in a distribution system malfunctioning. Energy savings from checking steam traps and follow-up maintenance is conservatively estimated at 10%. One industrial case study indicates a payback period of less

than four months. Although this measure offers quick payback, it is often not implemented because maintenance and energy costs are generally separately budgeted. In addition to energy and cost savings, properly functioning steam traps reduce the risk of corrosion in the steam distribution system.

**Monitor steam traps.** Attaching automated monitors to steam traps in conjunction with a maintenance program can save even more energy without significantly adding costs. This measure is an improvement over steam trap maintenance alone, because it gives quicker notice of steam trap failure and can detect when a steam trap is not performing at peak efficiency. This strategy can provide an additional 5% in energy savings compared to steam trap maintenance alone, at a payback period of about one year. Systems that can implement steam trap maintenance are also likely to be able to implement automatic monitoring.

**Repair leaks.** As with steam traps, steam distribution piping networks often have leaks that can go undetected without a regular inspection and maintenance program. The U.S. DOE estimates that repairing leaks in an industrial steam distribution system will lead to energy savings of about 5% to 10%.

**Recover flash steam.** When a steam trap purges condensate from a pressurized steam distribution system to ambient pressure, flash steam is produced. This flash steam can be recovered and used for low-grade applications, such as space heating or feed water preheating. The potential for this measure is site dependent, as its cost effectiveness depends on whether or not areas where low-grade heat is useful are located close to steam traps. Where feasible, this measure can be easy to implement and can save considerable amounts of energy.

## 5.7 Chillers

Concreting at elevated temperatures can affect the properties of concrete. When the ambient temperature is high, many concrete facilities produce chilled water to cool raw material and use it as batch water. Other methods of concrete pre-cooling include cooling mixing water with liquid nitrogen, cooling concrete with ice, and cooling concrete with liquid nitrogen (ACI, 1991). This section focuses on energy efficiency improvements in chillers. Information on other methods of concrete pre-cooling can be found in Section 6.9.6.

There are two types of chillers; mechanical compression and absorption chillers. Mechanical compression chillers are composed of a) an evaporator, b) a compressor, c) a condenser, and d) an expansion valve. The chiller cycle initiates in the evaporator, where the liquid refrigerant absorbs heat from the chilled water and evaporates. The refrigerant vapor is then drawn out of the evaporator by the compressor which increases the vapors' pressure and temperature, and 'pumps' it into the condenser. In the condenser, the refrigerant vapor gives up heat to the cooled water and condenses. The high pressure refrigerant liquid expands in the expansion valve and the whole refrigeration cycle starts again. Mechanical compression chillers are classified based on the type of compressor used: reciprocating, centrifugal, and screw (U.S. DOE, 2010).

Absorption chillers and mechanical compression chillers consist of the same evaporation and condensation cycles. The main difference is in the way the refrigerant's temperature is increased for the condensation process; mechanical compression chillers employ a compressor while



absorption chillers use heat (usually steam) (U.S. DOE, 2010). Absorption chillers use two working fluids; a refrigerant and an absorbent.

The [Chilled Water System Analysis Tool](#) (CWSAT) is a software tool provided by U.S. DOE to help energy and plant managers identifying efficiency improvements in chiller water systems. The user is able to make changes on equipment such as chiller, pumps, and towers and determine the energy and cost savings by implementing these changes.

There are several ways to improve the chillers' efficiency and reduce operational costs (U.S. DOE, 2010):

*Raise chilled water temperature.* The energy use in both types of liquid chillers (mechanical compression or absorption chillers) increases as the temperature difference between the evaporator and the condenser increases. By raising the chilled water temperature, the evaporator temperature will increase thus, decreasing the required temperature lift.

#### Did You Know?

On a centrifugal chiller increasing the temperature of the chilled water by 2°F to 3°F can improve the systems' efficiency by 3% to 5%.

*Reduce condenser water temperature.* Similarly, decreasing the water temperature in the condenser will limit the temperature difference between the condenser and the evaporator, thus decreasing the required temperature lift.

*Keep heat transfer surfaces clean.* Heat transfer efficiency in the chiller system can decrease due to mineral or sludge built-up on the heat transfer surfaces. Regular cleaning will improve the system's efficiency.

*Remove trapped air from the condenser.* Trapped air in the condenser limits the cold surface exposed to the refrigerant. This can be overcome only with higher pressure (and temperature).

#### Did You Know?

On a centrifugal chiller increasing the temperature of the condenser water by 2°F to 3°F can improve the systems' efficiency by 2% to 3%.

*Maintain the water flow in the condenser.* Blockage of the filter in the condenser water line (used in the majority of chillers) will result in an increase in condenser refrigerant temperature due to less efficient heat transfer.

*Use naturally occurring cooling water.* When outside temperature is not very high, naturally occurring cool water could be used instead of chilled water when available. See also Section 6.9.6.

*Manage the load.* Plants with more than two chillers can reduce their energy use by managing the load carefully in order to obtain combined peak efficiency. The use of a reciprocating chiller in combination with a centrifugal chiller is an example.

*Heat recovery.* Heat recovery systems can extract heat from the chilled liquid that can be used along with energy of compression to warm the circuit water for reheat and cooling.

*Use absorption chillers.* Absorption chillers could replace mechanical chillers to limit the facilities' electricity use.

*Replace absorption chillers with electric drive centrifugal chillers.* In a typical absorption chiller 1.6 Btu of thermal energy are required to remove 1 Btu of energy from the thermal water. However, only 0.2 Btu of electric energy is required in modern electric drive centrifugal chillers to remove 1 Btu of energy from the thermal water.

*Optimize the performance of auxiliary equipment.* Opportunities to improve the efficiency of the auxiliary equipment used in the chiller systems, such as compressors, pumps, motors, and fans can be found in the previous sections of the Energy Guide.

A more detailed description of energy efficiency opportunities in chiller systems is provided by U.S. DOE (2010).

## **5.8 Dust Collectors**

Fabric bags or cartridge collectors are usually installed on the top of cement and fly ash silos to capture dust generated when the silos are filled or drawn down. Dust generated during truck loading or at the weigh hoppers is driven via a vacuum flow to the dust collectors. To ensure proper operation of dust collectors, pulse air jets, mechanical shakers, bags and cartridges need to be inspected regularly, fabric bags need to be sized correctly and fitted properly, and all the worn fabrics should be replaced (MEMS, 2010).

Titan America has regularly observed during plant assessments that dust collectors may operate all day through, although it is only required during truck loading (Bayne, 2011). Significant energy savings are expected when the motors used to drive the dust collectors shut down when not needed; see also the Automated Motors in Section 5.3. Based on plant assessments by Titan America (Bayne, 2011), a number of best practices have been identified that can ensure efficient operation of baghouse filters at minimum energy requirements:

- *Seal areas*, as the existence of leaks will increase draft requirements.
- Employ the *minimum effective draft*. Extra draft employment will accumulate more dust on the filters resulting in increased wear of ducts and bags. Use dampers and/or variable speed fans to control the draft.
- *Automate dust collectors* so that they don't operate when not needed.
- Resizing and slowing down fans that are too big will result in energy savings. Installing an adjustable speed driver (ASD) will require higher capital investment but will result in increased energy savings.
- *Maintain a differential pressure* across the dust collector (pressure difference between the dirty and clean side of the bags) between 4 to 5 inches of water. For the efficient operation of dust collectors filters should be relatively dirty or have a dust cake.
- Use a *differential pressure control system* on your cleaning system. Differential pressure should range between 4 and 5 inches of water when a fan driven dust collector is used.

- When a compressed air jet pulse cleaning system is used employ the *minimum effective pressure* which usually ranges between 60 and 70 psi, and not more than the manufacturer's recommended pressure when a pneumatic shaker is used.
- Employ a *rather short pulse* to shake the extra dust off in the case of compressed air blow down systems.

## 6 Energy Efficiency Opportunities for Concrete Production Processes

The measures described in this section of the Energy Guide address the energy efficiency of practices, processes, and technologies used specifically in the U.S. concrete manufacturing. There is a big variety of energy and material efficiency measures that could yield substantial cost savings, while at the same time increasing or maintaining plant throughput and in certain cases even improving product quality. Generally, the processes along with the relevant measures follow the concrete production steps.

Case studies present the results of implementing specific measures, achieved cost savings and payback periods. The resulting energy, material, and labor savings each vary from plant to plant, as they are dependent on plant capacity, plant configuration, plant location (especially for curing and cold weather concreting) and operating conditions. The investment for specific measures is presented, where possible, and it can range from relatively low to relatively high. Table 9 lists all the efficiency improvements applicable to the concrete industry.

### 6.1 Pneumatic Conveying

Cement and fly ash are transferred to the batching plant with trucks, barges and ships, and are stored in elevated silos. One of the most common ways of transporting materials to the silos, is through pneumatic conveying. Pneumatic conveying is preferred in the concrete and cement industry as it offers dust-free transportation, low maintenance and labor costs, flexible routing, improved automation and control, and ease of transportation of multiple products through a single pipeline (Klinzing et al., 2010).

The disadvantages of pneumatic conveying are the high power consumption, as it requires large amounts of compressed air, and the wear of equipment. Lack in process monitoring, equipment maintenance, and inappropriate design leads to inefficient operation and increased electricity costs.

**Optimum conveying velocity.** The main parameter in the operational costs of pneumatic conveying is the conveying velocity developed in the pipes. Higher velocities than optimum, to overcome gravity and transfer cement or fly ash to the silos, lead to higher power consumption and increased wear of the equipment (Klinzing et al., 2010). The conveying velocity needs to be closely monitored and kept slightly higher than the optimum velocity for the system to consume the least amount of energy (Optimum velocity is named saltation velocity in horizontal conveying and choking velocity in vertical conveying). Great care is crucial, as lower velocities than the saltation velocity will lead to the blockage of pipes and collapse the whole system. The savings in power consumption have often been close to one million kWh in a year (Klinzing et al., 2010).

**Size pipe length and bore correctly.** The installed pipe length needs to be assessed carefully, as product throughput decreases with the increase in pipe length. For ordinary Portland cement, the mass flow rate decreases exponentially with length, from 150 ton/hour for a 55 yd (50 m) pipe it drops to nearly 70 t/hour for a 220 yd (200 m) pipe to around 15 t/hour in a 550 yd (500 m) pipe; an overall reduction of 10 times (Marcus, 1985 cited in Biege et al., 1998). It is obvious that more energy is needed to convey the same amount of material to the silos when a longer pipe is

used instead of a shorter one (Klinzing et al., 2010). When conveying material with very good air retention properties (i.e. cement and fly ash) at a constant flow rate of 20 t/hour, in a pipeline bore of 2-10 inches (50-250 mm), the power requirements are 25 kW when conveying the material in a 110 yd (100 m) pipe, and around 225 kW when conveying the same material in a 550 yd (500 m) pipe; an overall increase of 9 times (Mills, 2004).

Considering the size of the pipe bore, the power needed for a 10 inch (250 mm) bore is nearly six times higher than the power needed for a 2 inch (50 mm) bore (Mills, 2004).

**Minimize Wear.** Depending on product characteristics (i.e. cement is an abrasive material), and the conveying velocities employed, there is increased wear of pipes (especially in the bends' area), valves, cyclones and filters. Keeping the conveying velocity low ensures lower wear of the equipment.

It has been shown in a number of commercial plug conveying systems (Gattys, Fluidstat/Turboflow, Trace Air/Dynamic Systems) employing low conveying velocities, that significant energy savings can be achieved while reducing equipment wear (Klinzing et al., 2010). The operating principle behind these techniques is the transportation of the product in plugs. These special pipes have high capital costs but the cost is balanced by a lower demand in electricity.

**Switch from dilute phase to dense phase.** For powdered materials with very good air retention properties, like cement and fly ash, the minimum conveying velocities conducted in a dilute phase conveying system range between 11-13 yd/sec (10-12 m/sec). These materials can also be conveyed by using a dense phase conveying system requiring a minimum conveying velocity of only 3.3 yd/sec (3 m/sec). As seen in Figure 8, the type of pneumatic conveying system depends on the conveying distance. The transition point from dense to dilute phase is not very clear; it takes place when the conveying distance ranges between 300-400 meters.

In Figure 8 it can be seen that when cement and fly ash are conveyed over a distance less than 330-440 yd (300-400 m), and for a variety of material flows and pipe bores, the dense phase can be used instead of the dilute phase. This results in significant electricity savings. According to a case study, the power intensity for conveying 200 short tons of cement per hour, over a distance of 110 yd (100 m) horizontally and 330 yd (300 m) vertically is 1.1 kWh/short ton cement when a dense phase is used and 1.45 kWh/short ton when a dilute phase system is used (Biege et al., 1998).

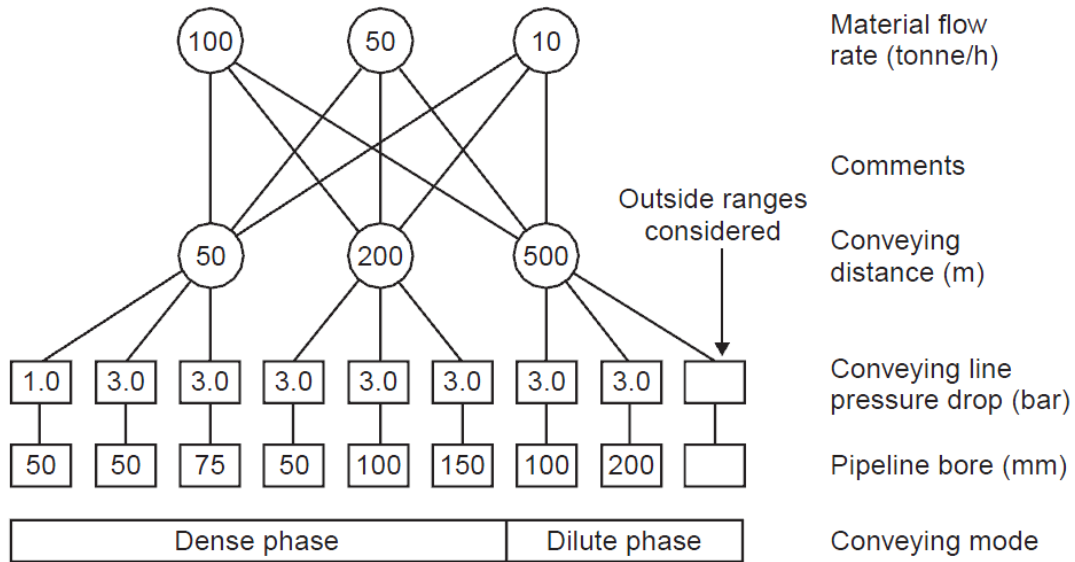

**Figure 8. System capabilities and design parameters for materials with very good air retention (i.e. cement and fly ash)**

*Source: Mills, 2004.*

Dense phase conveying is less electricity intensive than dilute phase conveying. An energy assessment should be performed to weigh all relevant factors including capital costs, preference for use of specific prime movers, feeders, etc. The capital and installation costs of a dense phase conveying system are around 12% higher than that of a dilute phase conveying system (Bartholomew and Hilbert, 1984 cited in Biege et al., 1998).

**Switch to mechanical conveying.** Mechanical conveying of cement is less power intensive than pneumatic conveying. Typical power intensity of mechanical conveying is around 0.5 kWh/short ton of cement. The replacement of pneumatic conveying with mechanical conveying results in significant power savings (Biege et al., 1998). Power savings depend on the type of pneumatic conveying substituted, 0.9 kWh/short ton for substituting dilute phase, and 0.6 kWh/short ton for substituting dense phase systems. As the energy intensity in pneumatic conveying is highly dependent on the pipe length, the power savings can reach up to 1.7 kWh/short ton when substituting dilute phase and 1.2 kWh/short ton when substituting dense phase systems (Biege et al., 1998).

Capital costs combined with installation costs for a mechanical conveying system using an elevator may be 40% higher when compared to the same costs for dilute phase conveying, and 25% higher when compared to the same costs for a dense phase conveying system (Bartholomew and Hilbert, 1984 cited in Biege et al., 1998).

## 6.2 Cold Weather Concreting

When ambient temperature is low, the temperature for concrete mixing needs to increase to compensate for heat losses during the placement of concrete. According to the ACI Committee (2002), cold weather is defined as an average daily temperature of less than 40°F (5°C), and an air temperature not more than 50°F (10°C) for more than 12 hours.

For general measures and more details concerning the desired temperatures of water and aggregates, the report ACI 306 for Cold Weather Concreting and the guidelines in the Standard Specifications for Ready Mixed Concrete (ASTM C94) are recommended.

When aggregates are free of ice and frost, and air temperature is above 25°F (-4°C), the desirable temperature for concrete mixing can usually be attained by heating the water. When ambient temperature is below 25°F (-4°C) the aggregates must be heated as well. When coarse aggregates are dry and free of ice, frost and lumps, the desirable concrete temperature can be achieved by heating only the fine aggregates.

There are various ways to heat aggregates. The most common include 1) aggregates stored in bins or weigh hoppers heated with steam coils or live steam 2) aggregates stored in silos heated with steam coils or hot air, and 3) stockpiles placed over heated pipes (PCA, 2002).

Ready mixed concrete (RMC) production in cold climates is energy intensive due to the energy requirements of water and aggregate heating. Energy intensity in RMC plants can range from 38-510 kBtu/yd<sup>3</sup> (50-700 MJ/m<sup>3</sup>) depending on whether aggregates and hot water are heated or not and the state of the equipment (*fib*, 2003; *fib*, 2004). The most significant energy savings are realized when the boiler efficiency is improved, and the water content of coarse and fine aggregates is kept low.

The energy efficiency improvements in this paragraph focus on lowering the water content of aggregates prior to heating. For energy efficiency improvements in boilers and steam distribution systems see Section 5.6 (Hot Water and Steam Systems).

**Provide shelter.** The energy requirements of drying aggregates with typical water content of 5%, is around 23 lb of steam/h per short ton of aggregate. When water content doubles, the steam requirement increases to 39 lb of steam/h per short ton of aggregate; an increase of almost 60% (Stamper et al., 1979). Thus, storing aggregates under shelter can lead to significant energy savings (Stamper et al., 1979; Ang et al., 1993).

**Create paved and sloped areas for stockpile storage.** Aggregates are usually stockpiled on the ground, without any precautions for water drainage, resulting in aggregates with high water content, especially at the base of the stockpile. Another undesirable result is the loss of raw material as aggregates slowly become buried in the ground and are lost to the soil or contaminated.

According to Simmons (no date) when the area in an asphalt-mix plant, underneath the stockpiles, was paved and inclined, the aggregate moisture content decreased by nearly 2%. Decrease in the water content of aggregates by 2% results in nearly 30% lower steam use for drying (Stamper et al., 1979). Additional benefits accrue as fewer raw materials are mixed with the soil (3% material savings). Fuel is saved as well as less is required for mobile equipment when storage areas are paved.

The aggregate annual savings for an average capacity (60,000 yd<sup>3</sup>) facility are estimated to be \$35,400 (\$0.6/yd<sup>3</sup>). The cost of paving an area of 3,500 yd<sup>2</sup> is around \$19,500 (\$5.5/yd<sup>2</sup>) (Simmons, no date). The corresponding payback period was estimated to less than 7 months. Interestingly, paving the area underneath the stockpiles can be accomplished at no additional cost as unused concrete returned to the plant can be put to good use in this way. Thus, \$35,400 in savings can actually be achieved at no additional cost with direct benefits to the plant.

**Adjust stockpile height and capacity.** Fine and coarse aggregate stockpiles should be treated differently as they do not behave similarly when exposed to rain. In a study conducted in an asphalt-mix plant (Thissen, 2010) it was observed that river sand loses moisture while recycled asphalt gains moisture with time.

By increasing the capacity and decreasing the height of the stockpile, river sand is provided more time to drain. The opposite would be true for aggregates which gain moisture over time. These two measures are reported to have decreased heating costs significantly (Thissen, 2010). Although these savings are based from a case study of an asphalt-mix plant where aggregates need to be dried prior to their use, the same measures could be applied to aggregates that gain or lose moisture in the concrete industry to keep the aggregate water content low and decrease the energy use for heating aggregates during the cold periods.

**Insulate bins.** Tarpaulins can be used to cover the bins or stockpiles when they are heated. In this way less heat is lost, formation of ice and crystals is avoided, and aggregates are helped to heat more uniformly (ACI Committee, 2002). Also, improvements in bin and silo insulation decrease heat losses.

**Process Control.** Control of concrete temperature is an important factor in successful cold weather concreting. The concrete temperature should not be higher than 15°F (8°C) higher than the minimum temperature requirements during mixing (ACI Committee, 2002). Several parts of the aggregate and water heating process should be controlled as the overheating of aggregates or water can have detrimental effects on the final product.

Thermostats should be installed in aggregate bins to shut down the heaters when the required temperature has been reached to avoid overheating. An automatic control system is useful in adjusting the air or steam flow in each bin to avoid variations in aggregate temperature.

**Maintain bins and storage silos.** Leaks can develop in the aggregate bins and storage silos. Detect leaks and fix them, otherwise overall heating efficiency will be reduced (ACI Committee, 2002).

**Choose an appropriate method for heating aggregates.** According to the ACI Committee (2002), the most appropriate way of heating aggregates is by circulating steam in pipes. Heating aggregates with hot air or steam jets directly into the aggregate bin is more thermally efficient (50% less energy), but causes humidity variations. However, their use is the only viable option when large volumes of frozen aggregates need to be heated.



### 6.3 Humidity Control

The strength and flowability of concrete is highly dependent on the water content of the concrete mix. This can be partly controlled by protecting aggregates in silos or covered areas, but a precise way to control the moisture content is crucial for the product's final properties. An undetected 2% water increase in fine aggregates, and 1% water increase in coarse aggregates will result in extra water in the concrete mix of 4½ gallons per yd<sup>3</sup> of concrete (22½ liters/m<sup>3</sup>) decreasing the compressive strength by 12% (VDOT, 2011).

Accurate control of the water to cement ratio is translated into less cement and admixture consumption per ton of concrete produced. Thus limiting inaccuracies in water content calculations will improve the product's composition, and will result in raw material savings.

**Turn a “dry-batch” plant into a “wet-batch”.** Many concrete plants use moisture meters to determine the moisture content of aggregates. However, their calibration can be awkward, leading to errors in the estimation of water content. In a “dry-batch” plant, all ingredients are mixed in the truck, and any errors in the calculation of the water content in aggregates will be directly converted into errors in the amount of added water (Cazacliu and Ventura, 2010).

Cazacliu and Ventura (2010) have shown that the addition of a central mixer in a ready mixed concrete facility can improve water control, and when accurately used achieve significant savings in cement consumption, estimated at about 34 lb/yd<sup>3</sup> (20 kg/m<sup>3</sup>). In a “wet-batch” plant all raw materials are mixed in the central mixer. Each time a batch is mixed, the proportions of each material are adjusted according to product specifications. In a number of concrete plants the water content of a mixed batch is also estimated i.e. from the change in power consumption during mixing. The plant operator can use this information to adjust the amount of water to be added in the next batches (when more than one batches are needed to fill the truck), correcting any errors in the water content in the mixing truck (Cazacliu and Ventura, 2010).

The cost savings of reducing cement use, for a “dry-batch” plant with an annual production of 60,000 yd<sup>3</sup>, assuming a cement price of \$90/short ton cement, amount to \$90,000/year. Annual electricity costs are estimated to increase by \$17,000/year. The additional maintenance cost is estimated at \$12,000 (Cazacliu and Ventura, 2010). Capital costs for a 2.6 yd<sup>3</sup> (2 m<sup>3</sup>) mixer range from \$70,000 to \$210,000 (Cazacliu and Ventura, 2010). A typical payback period is estimated to range between 1 and 3 years.

**Install microwave sensors and automatic water control.** Water content in fine and coarse aggregates needs to be carefully controlled, as fluctuations result in lower product quality. Microwave humidity sensors can be installed in the aggregate bins or in the conveyor belt, but they can also be installed inside the mixer (Boscolo et al., 1993; Wang and Hu, 2005). An automatic control system, takes information from the sensors and adjusts the water in the mixer. In this case the amount of cement used is optimized.

According to Hydronix (2006) the cement savings from adopting sensors and an automatic water control system are around 6 kg/short ton of concrete. For a 60,000 yd<sup>3</sup> production capacity the annual savings in cement consumption are estimated at 820 short tons. Considering a cement

price of \$90/short ton, the annual savings reach \$74,000. The payback period is reported to range between 2 and 6 months.

More benefits can occur by mixing the batch for the minimum required time, resulting in electricity savings and high product homogeneity. For more information read Section 6.4 Mixing.

## 6.4 Mixing

Every concrete product requires mixing. Mixing along with curing and mix composition plays a key role in the final product's microstructure which defines the compressive strength and durability of the final concrete product (Ferraris, 2001).

Two main types of concrete mixers, batch (most common) and continuous mixers, have different uses. Continuous mixers are used where significant amounts of concrete are required along with a continuous output.

Mixing energy requirements are determined by the power consumption during a mixing cycle, and depend on the concrete mix, mixer type, size of the batch, and the loading method. The mixing energy consumption is influenced by many parameters and cannot be considered a good indicator of the mixer's efficiency (Ferraris, 2001). For example, a powerful mixer batching a high viscosity, low workability, concrete mix can have the same energy consumption with a less powerful mixer batching a lower viscosity and more workable concrete mix. In this report, an efficient mixer is defined as the mixer that mixes all concrete constituent materials in a uniform way without favoring one over another, at the least amount of energy.

**Optimize mixing time.** Johansson (1971) measured the homogeneity of a fresh concrete mix while varying the duration of the mixing cycle. One outcome was that homogeneity increased as the mixing cycle increased - but only to a certain point. After this point was reached, homogeneity did not increase further. By tracking the mix homogeneity a shorter mixing duration can be determined. The result can be shorter mixing cycles and reduced power consumption.

Different concrete mixes need different mixing times to reach the optimum uniformity (Rupnow et al., 2007). If a batch plant produces a variety of concrete products in varying volumes, then an equal mixing time for all batches may not be appropriate. It is also common practice in some facilities, when High Performance Concrete (HPC) and Self Consolidating Concrete (SCC) are manufactured, to increase the mixing time resulting in high power consumption and low productivity (Chopin et al., 2007). By keeping track of homogeneity, the optimum duration mixing cycle can be determined for each mix.

Two ways to determine concrete homogeneity are 1) to track power consumption change during mixing, and 2) to use humidity sensors (Chopin et al., 2007; Cazacliu et al., 2002).

*1) Track power consumption change during mixing.* According to Chopin et al. (2007), tracking of power consumption can help determine the product's homogeneity during batching. The

reason is that power consumption is related to the resistive torque produced by the mixing of materials.

In several facilities, the power consumption curve, (power consumption (kW) vs. mixing time (sec)) is recorded and is used to determine the best time to discharge the mixer. When the curve shows a plateau (i.e. a place on the curve where power consumption does not change with mixing time), it is an indication that product homogeneity has been reached and the product microstructure has been stabilized (Chopin et al., 2007).

Tracking the changes in power consumption can be used to control and alter (if needed) the material flowability, assess the optimum mixing duration, and determine the best mixer type for the application.

2) *Use humidity sensors.* According to Wang and Hu (2005), humidity sensors, when used appropriately and except from determining the water content of the concrete mix, can also determine product homogeneity. The results deriving from the use of humidity sensors can be used to improve product quality and optimize the mixing cycle. Energy savings can occur from fitting the mixing duration closer to the optimum. For more information on humidity sensors, see Section 6.3 (Humidity Control).

### Case Study: Humidity Sensors

Located in Southern Bavaria (Germany), a concrete block, manhole and prefabricated garage production facility, had to deal on a daily basis with water additions in the concrete mix and lengthy mixing cycles. The installation of a microwave sensor showed that the mixing cycle could be reduced without affecting product quality (Hydronix Ltd., 2005). Prior to the sensor installation, the dry mixing lasted around 80 seconds. The microwave sensor showed that 40 seconds of dry mixing would be optimal. The mixing cycle was optimized, power consumption was reduced, and mixer wear was reduced. Another problem the sensor highlighted was that the wet mixing cycle should be extended to achieve product homogeneity. In the end, product quality was improved and the overall mixing cycle was reduced.

**Mixer type.** When it comes to conventional mixes, no specific type of mixer produced a clear advantage in product quality (ISO 18650-1, 2004). Several factors should be assessed for the identification of the most suitable mixer for a specific application; i) distance from the job site ii) volume of concrete needed per hour iii) operational cost, and iv) product quality (most important). Regarding the mixing of special concretes (e.g. low water cement ratio), the use of a specific mixer type could be beneficial.

According to Chang and Peng (2001), twin shaft mixers were found to perform better than drum mixers in the case of High Performance Concrete (HPC) with low binder content, requiring less mixing time and power. The power consumption in a planetary mixer is reported to be 25% less than a pan mixer (Budny et al., 2009). Also, Shepherdson (2010), reports that planetary mixers require 15 to 25% less cement than spiral blade mixers.

Planetary mixers are characterized by increased maintenance costs (over the maintenance costs required for twin shaft mixers) as they are composed of many moving parts (Shepherdson, 2010).

**Increase mixer capacity.** It has been shown (Chopin et al., 2007; Cazacliu et al., 2002) that the mean stabilization time for a number of different mixtures decreases when the mixer capacity increases. When 80-liter mixers were used, the mean stabilization time was two times longer when 1000 liter mixers were used (Chopin et al., 2007).

**Multiple step mixing.** Multiple step concrete mixing is used in the U. S., the UK, Russia, Canada, Belgium, Poland and Japan to improve the properties of cement paste, mortar and concrete (Rejeb, 1995). Two-step mixing begins with mixing of cement, water and admixtures in a fast mixer at elevated speed rotations, to form a cement paste. The paste is then mixed with the required amount of sand and gravel. In three-step mixing the cement paste is formed. Then, fine aggregates are introduced to the mix forming a grout, and finally, the coarse aggregates are added to produce concrete.

Multiple step mixing reduces water requirements, increases fineness of cement and improves compressive strength. The benefits are the result of more intimate contact between cement and water under intense mixing (Rejeb, 1995). It has been reported that the compressive strength can increase by 10-25% depending on the method used, cement content and aggregate size (Rejeb, 1995; Rupnow et al., 2007). Three-step mixing is reported to increase compressive strength even more (Rejeb, 1996).

Multiple step mixing is suitable in cases where low quality products are used (e.g. poor cement, low strength aggregates). Multiple-stage mixing could result in cement savings (Rejeb, 1995). A two-step mixing innovative technology named FML-Concretec is manufactured in the FML Technology Center in Germany. According to FML Concretec, the possible savings in material costs can surpass 10%, as the cement content can be reduced and the w/c ratio can be changed, by replacing high quality cement with lower quality, and by replacing cement with supplementary cementitious materials (Reinecke, 2010).

The FML Concretec two-step mixing technology is used along with a water treatment facility. The combined system is claimed to be economically advantageous especially in the case of high capacity ready mixed plants (Reinecke, 2010).

It was shown that in the case of Self Consolidating Concrete (SCC) the long mixing cycles of 240 seconds could be reduced to about 60 seconds, when the low water content mix was initially mixed in an Eirich plant mixer achieving high velocities, and then homogenized in the truck mixers (Schießl et al., 2007; Lowke and Schiessl, no date).

**Cleaning and maintenance of mixers.** An efficient mixer is the one that produces high quality and homogeneous products. A prerequisite in mixer efficiency is proper cleaning and maintenance. Long usage of mixers results in wear of the blades and container, and accumulation of concrete material. The build-up of concrete can change the mixer geometry and affect the concrete production (Ferraris, 2001).

Mixer blades should be replaced or repaired when the radial height of the blade (at the point of longer container diameter) is less than 90% of the design radial height (Byron et al., 2004). The mixer should also be properly cleaned regularly to avoid concrete built-up.

## 6.5 Truck Operation and Fleet Management

Transportation of concrete to the construction site imposes one of the most significant costs to the concrete industry. Improving truck operation and fleet management will reduce concrete delivery time, and fuel consumption.

**Track fuel consumption.** Most RMC companies calculate the fuel consumption (mainly diesel oil), in mpg (miles per gallon). In 2010, the average fuel consumption was 3.4 mpg (Jones et al., 2010). The highest and the lowest fuel consumption appearing in the 2010 NRMCA survey was 7.0 mpg and 2.1 mpg accordingly (Jones et al., 2010). The power-take-off (PTO) fuel use was estimated at 20-25% of the truck's overall fuel consumption (Carew et al., 2007). The spread in fuel consumption suggests a significant potential for improvement. However, tracking only "miles per gallon" does not show the real picture, as trucks spend a significant amount of time idling, batching and traveling off-road. Tracking truck fuel consumption during the day enables optimization of fuel efficiency.

Fuel consumption can be simply determined by gathering information on the miles and hours a truck was driven and the time that was spent idling. More precise information on real time fuel consumption (or later in downloadable format) can be attained by installing diesel flow meters in the trucks. Diesel flow meters can help track truck efficiency and identify further improvement options, such as retrofitting or replacement.

**Reduce idle time.** According to the American Trucking Association (ATA), truck idling is responsible for 1.2 billion gallons of diesel fuel consumption annually (ATA, 2008). Drivers should be advised to shut-off the engine when away, or when idling for more than 5 minutes. The result is a \$6/hour savings in fuel (Downs, 2009). Titan America, after several months of collecting data on truck idling, estimated the average in-yard idle time at approximately 44 minutes per load, which corresponds to about 7.3 gallons per day per truck. Also, it was estimated that each truck consumes approximately 2.5 gallons per hour (9.5 liters/h) while unloaded (Downs, 2009). Reducing idling time by 50% could save the company \$500,000 in annual fuel costs for concrete delivery. Apart from fuel costs, maintenance costs will also decrease.

### Case Study: Reduce Idle Time

Titan America identified and promoted several best driver practices concerning truck idling. The result was 38% reduction in idle time within 2 months.

In collaboration with the truck drivers, Titan America identified a number of best practices (Downs, 2009), including:

- shutting-off the engine when washing the truck between loads,
- training fleet coordinators to improve truck dispatching,
- discovering driver misconceptions about vehicles,
- identifying technologies able to reduce idling time, such as a spray nozzle or a wash rack,
- wiring radios to the battery to avoid having the engine on to power the radio.

**Route optimization.** A route planning system such as GPS (Global Positioning System) can save fuel as a shorter distance to the construction site is identified. Care should be taken to consider other factors influencing fuel consumption such as road gradation and idling time.

In the NRMCA 2010 Quality Benchmarking Survey it was reported that one of the major reasons concrete is returned to the plant (14% of returned concrete) is because of delivery time or product over-mixing (NRMCA, 2011a). Optimizing the truck route and identifying the reasons for delays in delivery could decrease this percentage.

**Driver training.** Truck drivers play an important role in the truck's efficient operation and fuel consumption. Truck drivers should be trained in programs like the Concrete Delivery Professional (CDP) offered by the NRMCA. Workers are trained in worker safety, truck operation and maintenance, and environmental issues.

**Increase load size coefficient.** By dividing the average load size by the nominal full load size of the truck, and multiplying by 100, the load size coefficient is determined. The higher the load size coefficient (better truck utilization), the lower the transportation cost is. According to the 2010 Quality Benchmarking Report (NRMCA, 2011a), the average load-size coefficient was 83%, with companies reporting as high as 98% and as low as 60%.

### Case Study: Truck Operation and Fleet Management

In 2004, Marshalls (UK) decided to improve the truck operational performance. Marshalls invested in new lower emission, high fuel efficiency vehicles, reduced the use of contractors, improved driver training, and used centralized transport planning (British Precast, 2006). Overall performance improved and the transportation costs were reduced. Emissions were cut by an estimated 1,700 tons of CO<sub>2</sub> per year.

**Preventive maintenance.** A well structured preventive maintenance program can improve fuel efficiency, ensure (to certain extent) correct truck operation, and avoid undesirable breakdowns that require significant repair costs. The truck should be properly maintained in a good condition, by conducting regular inspections and service. Preventive Maintenance drain intervals are recommended for every 300 hours of truck operation, although in recent years, the recommended operating hours between inspections have increased to 424 due to the use of higher quality motor oils (Carew et al., 2007).

## 6.6 Curing

Curing is the process during which cement reacts with water (hydration process) to form a gel (calcium silicate hydrate) that binds all constituent materials together to create a strong and durable concrete product.

A main advantage of precast concrete is that under proper conditions, it gains compressive strength rapidly. Some precast facilities when high compressive strengths are not required when stripping the products, normal curing can be enough to facilitate the required strength. However, in most precast/prestressed facilities, the high compressive strength requirements cannot be attained without accelerated curing (PCI, 1997).

Accelerated curing enhances the natural curing with the addition of heat and moisture. Its main purpose is to speed up strength gain. Steam curing at atmospheric pressure is the most widely used type of accelerated curing (ACI, 1992). Steam curing varies between different products. For example, when masonry units are cured, the heat transfer and evaporation will be rapid as the mass to air ratio is high. On the other hand, when big precast products (e.g. pipes) are cured the hydration rate is low while they are placed in molds, and heat transfer is slow due to the high mass.

Other methods of accelerated curing, not widely used, are the infrared, electrical and oil curing, and curing with steam at elevated temperatures (autoclaving). There are also special treatments such as carbonation and accelerated drying and heating prior to forming (ACI, 1992).

The energy used for curing in precast facilities accounts for 40-60% of the overall energy consumption (Marceau et al., 2007). Any energy efficiency improvements will therefore result in significant energy and cost-savings.

**Improve insulation.** Many precast facilities use curing chambers made of concrete masonry units, usually with no or worn insulation, which results in significant heat losses and water condensation issues. Condensed water causes a number of undesirable problems, such as product quality deterioration, when water droplets drop on concrete products, and increased energy consumption as steam is transformed into water, thus losing energy that needs to be maintained by providing more energy.

By properly insulating the curing chamber, heat losses through irradiation and steam condensation can be reduced. The average payback period of insulating bare chambers is about 0.9 years (IAC, various years).

It has been observed that in several precast concrete facilities, the insulation is placed on the outside of the chamber walls (Atkinson, 2010). This configuration is highly inefficient, as except for heating the concrete products that need to be cured, the bricks composing the chamber are also heated. Insulation needs to be placed on the inside of the chamber.

**Case Study: Insulation**

Arthur Whitcomb, a manufacturer of concrete products, performed an internal production process audit in 2006 to identify possible ways to improve productivity and reduce energy consumption, without deteriorating product quality (Kraft Energy Systems Inc., 2010). The process audit revealed non-insulated curing chambers made of concrete masonry units. By insulating the chambers energy consumption decreased by 50%.

**Detect leaks.** Undetected and untreated leaks in curing chambers can result in increased heat losses. Repairing leaks and firmly closing doors can lead to significant energy savings.

**Process control.** Many precast facilities supply heat to accelerate the curing of concrete without controlling the temperature change and without monitoring the different stages of the curing cycle. Heat requirements for different types of concrete products and product weights can vary

significantly. It is essential to control concrete curing to use heat more effectively and ensure product quality.

Several aspects of curing need to be monitored such as humidity rates and rate of heat increase. The following are those that can have a significant contribution in the energy savings.

*Preset period.* The preset period is determined as the period after concrete batching and until the initial set of concrete. During the preset period, heat is not usually applied unless otherwise required. Energy savings and an increase in compressive strength can occur when steam curing is conducted as soon as setting starts (ACI, 1992).

It is crucial to identify in each case the preset time as exposing concrete products to heat before the end of a preset period will result in decrease of compressive strength and cracking, as not enough strength is attained to resist the internal stresses caused by thermal expansion (ACI, 1992).

*Utilize hydration heat.* By placing a temperature probe in the concrete product, the internal concrete temperature can be measured instead of the air temperature inside the chamber. In this way, the real heat requirements can be identified, as the heat of hydration also contributes to the curing of concrete. By determining the real heat requirements fuel is burned only as needed.

During warm weather the hydration heat can be enough for the development of high early concrete strength. Supplying the same amount of heat throughout the year is therefore not efficient.

*Period of maximum temperature.* The period that the maximum temperature should be maintained inside the chamber does not have to be equal to the period that heat is applied. According to the ACI (1992), in numerous plant studies it has been shown that if the heat is turned off after the maximum temperature is reached, and the chambers are well insulated, the decrease in the 12-hr compressive strength is not significant.

**Cement type.** When accelerated curing is needed, type III Portland cement is often used. The main difference from type I Portland cement is that the particles of type III Portland cement are finer. Fine particles are of preference as the contact between cement and water is more intimate, resulting in a more efficient concrete hydration (Rejeb, 1995). Very fine cement will therefore generate larger amounts of hydration heat that can be utilized. Great care should be taken though, as cracks can develop (Rejeb, 1995).

#### **Case Study: Superplasticizers**

A precast concrete facility located in Italy, manufacturing a variety of products, was curing concrete (cement type I) including a CE superplasticizer, for 18 hours at 140°F (60°C) in order to achieve strengths of 40MPa. By changing into NCE superplasticizer it was possible to decrease the curing duration to 16 hours, and the temperature to 68-72°F (20-22°C) (ambient temperature). In this way, energy consumption needed for curing the products was eliminated. To achieve that, the products were covered with insulating covers, utilizing in this way heat deriving from the hydration of cement (Khurana et al., 2002).



**Use admixtures.** Supplementary cementitious materials (SCMs) (or else called mineral admixtures) or chemical admixtures, in addition to improving a number of engineering properties of concrete products, can also be used for accelerating concrete curing. Supplementary cementitious (SCMs) materials are also called mineral admixtures. The addition of admixtures accelerates the attainment of compressive strength and reduces significantly the duration of the curing cycle. Many precast facilities use admixtures along with increased temperatures for accelerating curing during winter, and during the summer period they employ only increased temperatures without the addition of admixtures (ACI, 1992).

*Supplementary cementitious materials.* Microsilica (silica fume) is one of the most common supplementary cementitious materials used in the acceleration of the curing process. In combination with heat and moisture, they can increase the short- and long-term compressive strength of concrete (French et al., 1998).

The use of granulated blast furnace slag (BFS), under increased temperatures can considerably increase the short-term compressive strength of concrete (Mak, 1998). According to ACI (1992), curing temperatures employed should be above 140°F (60°C). It has been shown that the thermal activity of mixes containing BFS increases as the BFS content increases. The greatest degree of strength enhancement was achieved when 70% of the cement was replaced with BFS (Mak, 1998).

Fly ash has been used as a replacement of cement in concrete and its contribution to the acceleration of curing according to the ACI (1992) has been satisfactory. However, in order to trigger early strength gains, high temperatures of up to 190°F (88°C) need to be utilized. According to French et al. (1992) though, fly ash should not be used as a curing accelerator, as it decreases the long-term strength.

*Chemical admixtures.* Calcium chloride can effectively accelerate curing. However, its use should be avoided, when steel bars are used for product reinforcement, as corrosion can occur.

High Range Water Reducing (HRWR) admixtures (superplasticizers) are used in the precast/prestressed industry to produce high strength products, reduce the mixing water requirements (up to 20-25%), reduce the cement content, optimize the vibration energy, and reduce heat requirements in accelerated curing (Ramachandran, 1996; Hester, 1978). With the use of superplasticizers significant energy savings can occur as high strength can be gained at lower heating temperatures and/or through shorter curing cycles (Ramachandran, 1996).

Before the use of any admixture, trial batches should be conducted before proceeding to a full production use, as their use can delay the development of medium- and long-term strength, and possibly cause strength reduction (Mak, 1998). Also, the right admixture proportion should be identified for an economically optimum curing cycle.

**Autoclave replacement.** Autoclaves are pressure vessels supplying the vessel area with high-pressure steam, and are used for accelerating concrete curing. In the U.S. they are successfully used mainly in curing small size concrete products, like masonry units.

Autoclaving is more energy intensive than low-pressure steam curing. Energy intensity in curing with high-pressure steam is around 0.516 MBtu/yd<sup>3</sup> (0.712 GJ/m<sup>3</sup>) while energy intensity with steam at low-pressures is around 0.430 MBtu/yd<sup>3</sup> (0.593 GJ/m<sup>3</sup>) (Kawai et al., 2005). Therefore adopting a less energy intensive system, when possible, results in significant energy savings.

### Case Study: Autoclave Replacement

A concrete product manufacturing facility, situated in Anjou (Quebec), owned by Groupe Permacon, a division of Oldcastle Building Products Canada, Inc, replaced the autoclaves used for curing products, with a new curing facility. The autoclaves used were very inefficient, and unable to provide temperatures needed for curing concrete. The whole curing system was redesigned, and replaced by a steam generator and 11 new curing chambers. The overall cost was \$335,000. The payback time for the retrofitting was just over 2 years (CIPEC, 2011).

**Automated (Continuous) curing systems.** Automated curing systems are mainly employed in concrete masonry unit production facilities. These systems are said to offer a number of advantages when compared to conventional curing and handling techniques employed by the precast industry, such as lower operation costs, smaller space requirement, and less initial investment (ACI, 1992). The use of forklift vehicles is eliminated as materials are handled automatically, thus reducing fossil fuel consumption and duration of the curing cycle.

## 6.7 Returned Concrete

Annually in the U.S. it is estimated that 2% to 10% (average 5%) of the ready mixed concrete produced is returned to the batching plant; although return rates of 15% have also been reported (Obla et al., 2007; Argeles et al., 2010). The main reasons include slump loss during transportation and over ordering of concrete (Paolini and Khurana, 1998). According to current practice, fresh concrete is dumped at the plant site till it hardens. When hardened, front end loaders break it, load it into trucks, and it is disposed of in landfills. While still fresh, the driver can add water, sand or air entrained admixtures in order to make breaking easier (Paolini and Khurana, 1998).

Returned concrete instead of being disposed to landfills, can be reused in various ways. The advantages of repurposing the viable concrete are obvious: reduction in disposal, transportation, and water costs (when water is also recycled), reduced exploitation of natural resources, and reduction of landfill waste.

**Excess concrete reduction.** Reduce the ordering safety factor and improve estimations of the amount of concrete needed at the job site. The reduction of excess concrete production to the minimum, results in less concrete returned to the plant.

Another way to avoid high rates of returned concrete is by the use of GPS systems in agitating trucks, coordinated with a central control station. As a result, delays are avoided when possible, and changes in product delivery are handled more effectively.

**Reuse on the plant site.** Returned concrete can be reused on the plant site, by paving for example plant areas. In this way landfilling costs are avoided and dust emissions from trucks driving on unpaved areas can be reduced. Also, as mentioned in Section 6.2, returned concrete is valuable in providing a paved area to keep raw material clean and dry. Another way to use returned concrete is by windrowing (disposing fresh concrete and breaking it when hardened) fresh concrete and using it where needed, as a fill, road base or rip rap (Argeles et al., 2010).

Reuse of returned concrete on the plant site is restrained as there can be limited needs for paving or filling.

**Create precast products.** By placing returned concrete into molds, concrete blocks can be manufactured and then sold. Windrowing fresh concrete and crushing it can also create saleable products. Although this recycling option can be cost effective, it is highly dependent on local market conditions and market opportunities (Obla et al., 2007).

**Batch on top.** Small quantities of fresh returned concrete (less than 5%) can be used with the next batch without affecting its properties (Argeles et al., 2010). Hydration stabilizing admixtures (HSAs) can also be used to stabilize the hydration of cement. Hydration stabilizers with water are sprayed on the mixer's walls at the end of the day. The following day, the new concrete batch is placed into the truck, without reclaiming the previous days' returned concrete.

Although stabilizing admixtures are expensive, their use can be cost-effective when returned concrete is reused, disposal costs avoided and water use for truck washout reduced; 300 liters instead of 3,000 liters (Borger et al., 1994; Sealey, 2001).

This measure is usually adopted in small scale batching plants, and although it can be cost-effective, it is not considered always practicable as product specifications can limit its use (Obla et al., 2007).

**Stoning out.** An efficient way of cleaning the truck's drum mixer is by "stoning out" the returned concrete at the end of the day. The mixer is loaded with two tons of aggregate and 200 liters of water and is then brought to the point of discharge about 4 to 5 times. The mixture can either remain in the truck overnight and then used the next day - after making some adjustments - as part of the first batch, or placed on the top of the aggregates stockpile for future use (Sealey et al., 2001).

Stoning out is an efficient way of retrieving and reusing returned concrete as aggregates since it requires no investment, maintenance and admixture costs.

#### **Case Study: Waste Reduction**

To solve the problem of handling returned concrete, a ready mixed concrete facility in Watauga County decided to install a concrete reclaimer along with a water settling basin (DPPEA, 1995a). The initial investment was \$140,000. The annual aggregate generation was estimated at 5.1 million pounds, and the annual water recovery was 650,000 gallons (a part was also collected from run off water). The net annual savings were approximately \$45,000; the payback period was 3 years.

**Mechanical concrete reclaimer.** Concrete returned to the plant can be processed through a mechanical reclaimer, able to separate aggregates and grey water (slurry composed of cement and water). The reclaimed aggregates and grey water can then be used in the concrete mixer. Main advantages are reuse of returned concrete and elimination of wash out water.

The capital investment for obtaining a concrete reclaimer is significant and according to literature, can range from \$90,000 and \$350,000 (Tam and Tam, 2007; BIBKO, 2011). The equipment is highly complex and requires careful operation and maintenance (Sealey, 2001). The reduction in disposal costs varies from approximately 40% to 80%, depending on whether both coarse and fine aggregates are recycled or not. The net cost savings are highly influenced by disposal costs and the price of virgin coarse and fine aggregates. In an average ready mixed concrete facility (60,000 yd<sup>3</sup> annual production), the net cost savings for a \$16/ton disposal cost, can range between \$0.5 and \$2.5/yd<sup>3</sup> of concrete produced. The payback time is estimated to range between 2.5 and 3 years.

Recycling is limited in large ready mixed batching facilities as it requires high initial investment and careful operation (Obla et al., 2007). The payback time for larger facilities (more than 100,000 yd<sup>3</sup> per year) is less than 2 years.

**Mechanical reclaimer plus HSAs (100% waste recycling system).** Returned concrete is fed through a plume to a mechanical reclaimer. Coarse aggregates are separated and led to the coarse aggregate stockpiles. Cement and cementitious materials, along with fine sand and water are transferred to a primary tank while HSAs are added. By adding HSAs, hydration of cement is suspended and a part of its cementitious value is available for future use. The primary tank's content is then transferred to the second tank for use as batch slurry, while during transfer it is being mixed with fresh or process water in order to meet the customer's product specifications (Lobo and Mullings, 2003; Beckham, n.d.).

This recycling system reuses 100% of generated waste in a ready mixed concrete facility. Without the use of HSAs, the use of recycled concrete in batching would not be possible. There are a number of concrete facilities in the U.S., Europe and Japan successfully using this 100% waste recycling scheme (Lobo and Mullings, 2003). The economic feasibility will depend on the disposal cost of returned concrete and process water, on the cost of virgin aggregates and water and the rate of waste utilization achieved.

**Crushing and recycling concrete.** Fresh concrete, when returned to the plant site can be left to harden and used afterwards in a crusher for further processing. Crushed concrete aggregates (CCA) can then be used in concrete production or at the plant site, as road base or fill.

According to Obla et al. (2007) this recycling option has a significant potential in the U.S. and could be used to recycle 60% of returned concrete. The investment cost for an average crusher is estimated at \$70,000 (Joint Service Pollution Prevention; 2003).

Potential cost savings depend on whether returned concrete is separated into different strength classes, and into coarse and fine particles (Obla et al., 2007). When it is not separated into strength classes, the CCA content of aggregates used in concrete mixing should not exceed 10%

(assuming CCA is derived from lower strength returned concrete), as more cement and admixtures are required to compensate for strength losses. When separated by strength classes the share of CCA can increase to 30%, improving the cost benefits. When CCA is separated according to strength classes and particle fineness, the savings achieved are maximized.

The net cost savings vary according to the CCA separation scheme adopted and range between \$0.3 and \$4.0/yd<sup>3</sup> of concrete produced (Obla et al. 2007). For higher disposal costs, the net cost savings increase drastically and can range between \$3 and \$12/yd<sup>3</sup>. The payback period ranges from a few months to maximum of 4 years.

For product specifications and guidance concerning the use of CCA in batching, see “Standard and Specifications for Reclaimed Concrete Aggregate for Use as Coarse Aggregate in Portland Cement Concrete”.

## **6.8 Process Water**

Fresh water is a valuable, scarce and usually expensive resource. It should be used with great care. Water in ready mixed concrete plants is used in concrete batching (14-18% of fresh concrete is water), aggregate heating or chilling, truck and central mixer wash out, and in dust emission suppression operations where various facility areas are sprayed with water. In precast plants, water is mainly used for batching and curing.

Water consumption shows great variations for different facility types. Ready mixed concrete plants without a central mixer tend to consume more water for truck washing when compared to central mix plants, since the drum is loaded with dry materials instead of fresh concrete. Plants in rural areas where longer travel distances exist for product delivery, are likely to have higher water consumption as they mainly use transit mixers, and large plants in urban sites are more likely to have adopted a water recycling scheme (Argeles et al., 2010).

According to Marceau et al. (2007) (based on 27 ready mixed concrete plant responses), the average water consumption in a ready mixed concrete plant is 13 gallons/yd<sup>3</sup> (65 liters/m<sup>3</sup>) without including the water used in concrete batching, and 7 gallons/yd<sup>3</sup> (35 liters/m<sup>3</sup>) of water is typically disposed. Water that is not disposed is reused. In precast facilities there is no truck wash out/off, and water is used for product curing as steam or vapor. Around 170 gallons of water per yd<sup>3</sup> are used for curing while 100 gallons/yd<sup>3</sup> are discarded; the rest is lost as steam, and only a small amount of water is recycled.

Strict regulations on the disposal of process water produced in concrete facilities force plant managers to adopt water recycling schemes, following a trend toward zero-discharging facilities.

There are two main ways to reduce fresh water consumption and limit the generation of process water; a) use less overall water, and b) replace fresh water with recycled process water and captured stormwater. Reducing water usage and capturing process water can be cost effective as the use of municipal and well fresh water poses significant operational costs to concrete producers. Typical water costs range between \$0.02 and \$0.52/yd<sup>3</sup>. Well water plants spend around \$0.07/yd<sup>3</sup>, while plants using fresh water from municipal sources have the highest water

costs ranging between \$0.25 and \$0.52/yd<sup>3</sup> (Herbert, 2006). Recycling process water also limits the water discharge costs.

Standards prepared by the NRMCA, the ASTM C 1602 Standard Specification for Mixing Water Used in the Production of Hydraulic Cement Concrete, and the ASTM C 1603, Standard Test Method for the Measurement of Solids in Water explain how to recycle process water and use it in batching without deteriorating the product's quality.

### **6.8.1 Decrease Fresh Water Usage**

There are a number of measures that could be adopted to limit water consumption. The most water intensive operation is washing truck drums (50-200 gallons of water per truck). Water saving measures in this operation will have the greatest cost savings.

**Multiple low volume drum washouts.** Using multiple low volume rinses in drum washout, reduces water consumption by 50% (Argeles et al., 2010). One rinse of 250 gallons (950 liters) will clean a truck's drum as efficiently as a double rinse of 100 gallons (380 liters) twice, or a triple rinse of 50 gallons (190 liters) used three times (Argeles et al., 2010; Athena Sustainable Materials Institute, 1993). The annual savings in fresh water for an average ready mixed concrete facility can reach \$15,000.

**Use chemical admixtures.** With the introduction of chemical admixtures (water reducing and plasticizing) in batching, the fresh water demand can be reduced by 12-25% without having any negative effect on workability (U.S. Department of Transportation, 2011).

**Heating aggregates.** In cold weather concreting, it is common practice to heat the water and not the aggregates. Water can be conserved, by heating a small amount to create steam for aggregate heating. Also, a portion of the batch water can be heated instead of heating all of it (Argeles et al., 2010).

**Restrain fresh water flow.** Significant amounts of fresh water can be saved when flow-control nozzles or small diameter hoses are used.

**Shut-off valves.** Fresh water can be wasted when during water tank loading if the tank is overfilled. Installing a shut-off valve can prevent overfilling.

**Create curbs and gutters.** Generation of extra process water can be avoided by preventing stormwater from mixing with process water. Stormwater that becomes contaminated requires treatment. The creation of curbs and water gutters in the plant area will facilitate this measure.

**Water harvesting.** Aggregates during warm periods are sprayed with water to keep them cool. When the stockpiles are placed on paved and inclined areas, the runoff water at the base of the stockpile can be collected and reused in concrete batching or truck wash out/off. Storm water can also be captured and directed to settlement basins along with process water and reused in some plant operations.

## 6.8.2 Water recycling

For every cubic yard of concrete produced, around 7 gallons (35 liters/m<sup>3</sup>) of process water require disposal (Marceau et al., 2007). By limiting process water generation, process water along with stormwater can be collected, treated, and reused in concrete batching, but also in other operations (i.e. truck wash out/off), reducing the use of fresh water.

Several of the most promising methods of water recycling include the stoning out of returned concrete, the batch on top operation, the use of a mechanical reclaimer, and the use of a mechanical reclaimer with HSAs. Read more in Section 6.7 (Returned Concrete).

**Create settlement basins.** Settlement basins are the most prevalent way of treating process water for future reuse (Argeles et al., 2010). Process water is collected from truck loading and cleaning areas, and is driven to a water basin system composed of a number of ground basins usually placed side by side. Process water enters the first basin and as the water volume increases, it overflows to the next one till it ends up free of solids (solids are heavier and settle to the bottom of the early basins). The basins should be properly maintained and solid wastes collected regularly. After sedimentation, water is pumped into a water tank with a minor impact on plant energy consumption.

If the solid concentration is not dropped to desirable levels, cloth filters can be deployed. Maintenance and cleaning of cloths can maintain low solid concentration.

At the last basin, water is treated to reduce the pH levels according to regulations (lower than 9 relative units). pH treatment is done by mixing process water with an acid solution or by injecting carbon dioxide (Millennium EMS Solution Ltd., 2010).

## 6.9 Miscellaneous

### 6.9.1 Streamline raw material handling

Around 16% of the energy used in ready mixed concrete facilities is used for the operation of light trucks (fork lifts, front end loaders etc.) (Marceau et al., 2007). Light trucks consume as much as 5-10 gallons of diesel per hour (19-38 liters/hour) (Argeles et. al, 2010).

Significant savings in diesel fuel can occur when conveyor belts in combination with aggregate feed hoppers are used to facilitate the transfer of aggregates to the mixer. In addition, when underground aggregate storage facilities are installed, in combination with a conveyor belt (horizontal plant configuration) the use of front-end loaders can be eliminated, leading to substantial fuel and labor savings. The capital costs for an average ready mixed concrete facility

### Case Study: Water Recycling

Fabcon Inc., a precast and prestressed concrete facility in Minnesota, to handle the increased generation of process water and the additional cost for water treatment, installed a closed loop system able to recycle all process water generated at the facility. The system was composed of series of plates to capture and remove solid particles. The recycling system provided all the water needed in the facility except for potable water. The annual savings generated from using recycled water were \$160,000 and the cost of equipment was approximately \$300,000 (DPPEA, 1995b).

are estimated around \$40,000 for aggregate storage, and \$45,000 for a 65 ft (20 m) troughed conveyor belt (ICF, 2002; Carter and Troyano-Cuturi, 2011; Walas, 1990).

The payback period is estimated to be approximately 1.3 years. However, this figure is expected to be a bit higher when the additional labor costs for operating the conveyor belt and the underground storage area are included. No information was available concerning the change in maintenance costs.

### **6.9.2 Automation in Precast Facilities.**

The use of automation in precast facilities significantly decreases the need for skilled labor, and the overall number of workers. Additional advantage is the ease in problem identification as each part of precast manufacture is monitored separately. Also, fewer mistakes are made when robots are given correct orders, and the product quality, and worker safety increases (Today's Concrete Technology, 2010). Unlike North America, automation in precast facilities has been used for several years in Europe.

In an automated plant, robots are used to prepare the molds, place the reinforcement, inserts and the concrete into the molds, transfer the pallets to the curing area and the cured products to the de-molding area, demold, and finally clean the molds. The robots are controlled by a central computer system receiving instructions from CAD (computer-aided drawing) data files.

Automation is appropriate for both standard and custom products. The time required to produce a certain number of products in a fully automated facility is the one third of the time required in a conventional precast facility to produce the same quantity of products. In Europe, labor costs have decreased by 50 to 70%. Energy costs can also decrease from the more efficient utilization of the machinery (Today's Concrete Technology, 2010).

Costs depend on a variety of factors; the degree of automation adopted (automation can be adopted in steps), whether it is a retrofit measure or a newly built plant, the type, size and quantity of products, and the desired product output per shift. Equipment costs for fully automated precast facilities in Europe have ranged between \$3 to \$5 million, while partially automated plants range between \$1.5 and \$3 million (Today's Concrete Technology, 2010). The payback time was estimated to 5 years.

### **6.9.3 Co-generation**

For industries with requirements in both heat and electricity, the installation of a combined heat and power unit can significantly reduce energy consumption, and as a result the associated greenhouse gas emissions. In the precast industry, heat is used in several operations; heating batch water, preheating the aggregates, heating the building, and concrete hardening. Electricity is used to power electric conveyors, the mixer, compressors, fans, pumps, etc.

This efficiency improving measure cannot be implemented in all concrete facilities. Its' adoption depends on a variety of factors; i.e. on-site heat and electricity requirements, local fuel and electricity prices, and initial investment.



CHP plants, are composed of a turbine/engine, an electric generator, and a heat recovery unit which utilize the generated heat from cooling the engine. In this way, fossil fuels are transformed into heat and electricity. CHP units are more efficient than conventional power plants as their main advantage is the utilization of exhaust heat during electricity production. Overall system efficiency can exceed 80%.

The payback period for a CHP configuration can vary widely. Assuming the implementation of a co-generation plant similar to the one in the case study but instead in the United States, the payback time would range between 2 to 7 years, depending on electricity prices. In 2009 electricity prices in various States ranged between 6.8 to 15¢/kWh (U.S.DOE-EIA, 2011). Based on a limited number of actual plant assessments in the U.S., the payback times for CHP installation range between 2 and 10 years (IAC, 2010).

#### 6.9.4 Optimize concrete mixture

According to the experimental case studies appearing in Obla et al. (2005), concerning the production of concrete floors and High Performance Concrete (HPC) blocks, the concrete mix optimization can yield significant savings in material costs. Material costs in the ready mixed concrete industry are responsible for more than 50% of the overall production costs – cement only accounts for about 24% (Olivarri, 2011).

By altering the consistency of the initial mixture (the initial mixture was designed according to the prescriptive specifications i.e. specific water to cement ratio (w/c) and specific cementitious content) while at the same time meeting the performance criteria, the material costs in the first case study decreased by 9-15% while in the second case study by 16-19%. The reduction in material costs was mainly achieved with the substitution of cement with cementitious materials, fly ash and granulated blast furnace slag. The substitution of cement with fly ash and/or blast furnace slag ranged from 20% to 50%. In addition, certain mixtures appeared to perform significantly better than the principle mixtures.

Portland cement is responsible for the 90% of the embodied energy in concrete (Marceau et al. 2007). Any reduction in the cement content of concrete mix will therefore result in a substantial reduction in the embodied greenhouse gas emissions.

#### Case Study: Co-generation

In a reinforced concrete pipe facility in South Ontario, Canada, a co-generation plant was installed (Ortwein, 2005). The main goal was to cover the on-site power requirements, as only in a few cases electricity surplus could be sold to the grid. During peak loads, electricity requirements would be partly covered by the grid. Two gas engines (2x360 kW<sub>electric</sub>/ 430 kW<sub>thermal</sub>) were installed, and a heat accumulator (2,650 kW). The Initial investment cost was CAN\$690,000 (approximately US\$550,000), and the annual maintenance costs CAN\$14,000 (approximately US\$11,000). Annual savings in operating costs were CAN\$320,000 (approximately US\$260,000).

#### Case Study: Mixture Optimization

Soil Retention Products (SRP), in Romoland, California, a producer of a variety of concrete products, produces concrete mix with up to 40% Class F fly ash content (Mc Craven, unknown date). By avoiding concrete mix overdesigning, by imposing specific cement content and w/c ratios, SRP can produce high quality and cost-effective products.

### 6.9.5 Self consolidating concrete (SCC)

Self-consolidating concrete, also called self compacting concrete (SCC), is used to substitute conventional concrete in some applications in Japan, Europe and the United States (Ouchi et al., 2003). In the U.S., the precast/prestressed concrete industry has shown an increasing interest in SCC during recent years. A number of precast concrete facilities reported using SCC instead of conventional concrete in nearly 100% of their production (PCI, 2003).

SCC can consolidate under its own weight, without the need of vibration. The main benefits are lower production costs and increased productivity (Grünewald et al., 2010). Other benefits are the 1) high quality, as it can fill gaps with ease without creating holes, 2) advanced aesthetic, it has a smooth finish and lighter colors, 3) design flexibility, it can be used in the production of complex designs, 4) increased durability, as it can form products with higher compression strengths than conventional concrete and with lower permeability, and 5) a safer working environment, as the noise of vibration is eliminated and dust emissions are reduced (Shutt, 2002; Grünewald et al., 2010). The elimination of vibration, results in electricity savings (5 kBtu/hour for a flexible shaft vibrator, 0.5 kBtu/hour for a form vibrator) (Kawai et al., 2005).

#### Case Study: SCC

The Newcrete Products Division of New Enterprise Stine & Lime Co. Inc. in Roaring Spring, Pa., uses SCC in the manufacture of a variety of concrete products. When SCC is used in tee (“T” -shaped product of the precast/prestressed concrete industry) manufacture, the premium costs per yd<sup>3</sup> of concrete are estimated to 3.5% (Shutt, 2002). These costs can be offset when taking into account the 46% decrease in total manpower per section and 44% decrease in patching labor per section throughout the year.

The main barriers for adoption of SCC are high material costs, as high quality products and more admixtures and additives are required, skilled labor, advanced quality control, high equipment accuracy, and the lack of applicable standards. The difference in materials costs, between SCC and conventional concrete, decreases as high compressive strength requirements increase (Grünewald et al., 2010).

When SCC is effectively produced, it can result in substantial cost gains mainly from reduced labor requirements, as labor costs from vibrating, repairing and patching of concrete can be eliminated, resulting in potential cost reductions of up to 46% (Shutt, 2002).

Although there are no design guidelines, PCI (2003) issued the [Interim Guidelines for the Use of Self-Consolidating Concrete in Precast/Prestressed Concrete Institute Member Plants](#) that can be used to ensure success in SCC product manufacture.

### 6.9.6 Concrete pre-cooling method

High ambient temperatures affect mixing, curing and placement of concrete, negatively affecting concrete properties. Potential problems are the decreased long-term strength (although under high temperatures the early-strength development increases), increased cracking, decreased durability, increased risk of reinforcement corrosion, increased permeability and deteriorated

product appearance. Most of these problems are associated with the increased rate of cement hydration and increased moisture evaporation under high temperatures (ACI, 1991).

There are several ways to control concreting at elevated temperatures. Aggregates can be stored in large capacity stockpiles, as temperature can remain low in the center, and in covered and shaded areas. Painting the mixing and hauling equipment in light colors can also be very helpful (ACI, 1993). In addition, raw materials can be pre-cooled. Methods for concrete pre-cooling are 1) cooling with chilled mixing water, 2) cooling mixing water with liquid nitrogen, 3) cooling concrete with ice, 4) cooling coarse aggregates and 5) cooling concrete with liquid nitrogen. A description of the various methods and their temperature reduction potentials can be found in Hot Weather Concreting and Cooling and Insulating Systems for Mass Concrete reports by the ACI Committee (ACI, 1991; ACI, 1993).

According to the ACI 305 report, one of the major means of reducing concrete temperature is by adding ice as a part of the batching water (ACI, 1991). The investment needed to install an ice-plant is high, thus the majority of concrete plants buy ice (Beaver, 2004). This method can be cost-effective for small batches, but other concrete pre-cooling methods could in some cases cost less. Thus, it is wise to first study and then select the most suitable pre-cooling option for your concrete facility.

*Evaporative cooling of aggregates.* Wetting aggregate stockpiles with water can in some cases decrease the temperature of concrete by a few degrees. For example if the wet-bulb temperature is 80°F (27°C) and the initial aggregate temperature is 90°F (32°C), evaporation can decrease the aggregate temperature to 84°F (29°C) (Lee, 1989). However, when lower temperature specifications are required, evaporative cooling alone will not be enough.

*Cool aggregates with naturally chilled water.* When available, naturally occurring cold water (i.e. from a well) could be used for batch water. The capital cost for a water pump, a pipe system to deliver chilled water to the stockpiles, and a water drainage system was estimated at \$18,000 (Lee, 1989).

*Chillers.* When naturally occurring cool water is not available, water chillers can be employed for cooling the aggregates and the batching water. This requires a large capacity water tank, sprinklers, water pumps, a water distribution and drainage system, and chillers. Despite the significant capital cost, this method costs less when significant amounts of concrete are cooled (Lee, 1989). Chilling can decrease the concrete temperature to 65°F (18°C). In some cases, the

### Case Study: Heat Pump

A concrete company, Hodgson Concrete (Alabama), identified an economical way to pre-cool concrete to meet 90°F (32°C) specifications (Smith, 1990). A three module heat pump was installed along with a 10,000 gallon water storage tank. Workers could add or remove modules according to the water needs. A heat pump was used to decrease the temperature of 10,000 yd<sup>3</sup> concrete by 6.5°F (14°C) and to increase the temperature of the same amount of concrete by 15°F (9°C). This resulted in annual savings of approximately \$44,000 over the use of liquid nitrogen and a gas boiler. The payback time was estimated to be less than 2 years.

increased operational costs due to water drainage and excess water handling can make the installation of an ice plant a more cost-effective option (Lee, 1989).

*Heat Pump.* A heat pump can be used for the production of warm water during the cold months and chilled water during the warm months. Despite its significant capital cost, it is considered to be the most cost-effective way of cooling batch water (ACI, 1991).

*Cooling towers.* Cooling towers require lower investment and are characterized by lower operational costs when compared to chillers (Lee, 1989). Water derived from cooling towers can be used for evaporative cooling of aggregates and can offer higher temperature reductions than evaporative cooling with natural water, as water from the cooling tower is colder. Temperature specifications of 85°F (29°C) or 90°F (32°C) can usually be met by installing a cooling tower or by using natural water. Based on a single audit, the payback period to replace a refrigeration system with a cooling tower is estimated at approximately 1 year (IAC, 2010).

*Liquid Nitrogen.* Under specific conditions, the use of liquid nitrogen can be less costly than using ice or chilled water (Beaver, 2004). When small batches need to be cooled to reach 60°F (16°C), directly spraying liquid nitrogen (LN) on fresh concrete may be more cost-effective than cooling water with ice (Lee, 1989). Pre-cooling concrete from 95°F (35°C) to 75°F (24°C) with LN, costs about \$7.5/yd<sup>3</sup>, while pre-cooling it from 95°F (35°C) to 85°F (29°C) will cost about \$4/yd<sup>3</sup> (excluding capital costs or rental of liquid nitrogen storage vessels). The capital cost of a permanent facility is around \$47,000, while a drive-through facility it is estimated at \$36,000 (Beaver, 2004). According to Juenger et al. (2007) except for a few exceptions, liquid nitrogen does not affect most of the concrete properties that were tested. Great care is crucial when slump is calculated as the initial high temperature increases slump loss, and when the liquid nitrogen injection lances are not properly aligned as they can damage the truck's drum (Juenger et al., 2007).

## 7 Summary

By increasing energy efficiency, companies can reduce costs and increase predictable earnings in the face of ongoing energy price volatility. Considering energy price volatility and recent sharp increases in natural gas prices across the nation, energy efficiency improvements are needed today more than ever. Many companies have already accepted the challenge to improve their energy efficiency in the face of high energy costs and have begun to reap the rewards of energy efficiency investments. In addition, companies are turning to energy-efficient processes and technologies to reduce their criteria pollutant and carbon emissions, to meet corporate environmental goals.

This Energy Guide has summarized many energy-efficient technologies and practices that are proven, cost-effective, and available for implementation today. These opportunities are applicable at the component, process, facility, and organizational levels. Preliminary estimates of savings in energy and energy-related costs have been provided for many of the measures, based on case study data from real-world industrial applications. Typical investment payback periods and references to further information have been provided, where available.

To be successful, establish a focused and strategic energy management program that helps you identify and implement energy efficiency measures and practices across your organization and ensure continuous improvement. Then assess your company's energy-using systems and identify areas for improvement. Tables 8 and 9 summarize the energy efficiency measures presented in this guide. Keep in mind that although the expected savings associated with some of the individual measures may be relatively small, their cumulative effect across an entire facility may be quite large. Many measures have relatively short payback periods and are therefore attractive economic investments on their own. The degree to which these measures are implemented will vary among plants and end uses, but continuous evaluation of your facility's energy profile will help to identify further cost savings over time. For all of the energy efficiency measures presented in this guide, research their economics and applicability to your facility's own unique production practices to assess the feasibility and potential benefits of each measure's implementation.

**Table 8. Summary of general energy efficiency measures**

<b>Energy Management Programs and Systems</b>	
Energy management programs	Energy assessments
Energy teams	Employee awareness
Energy monitoring	
<b>Building Energy Efficiency Measures</b>	
<b>Lighting</b>	
Turning off lights in unoccupied areas	Lighting level standards
Lighting controls	Daylighting
Replacement of incandescent with CFL	Replacement of T-12 tubes with T-8 tubes
Replacement of mercury lights	High-intensity discharge voltage reduction
High-intensity fluorescent lights	Electronic ballasts
Exit signs	LED lighting
<b>HVAC Systems</b>	
Energy-efficient system design	Recommissioning
Energy monitoring and control systems	Non-production hours set-back temperatures
Duct leakage repair	Variable-air-volume systems
Adjustable-speed drives	Heat recovery systems
Use of ventilation fans	Solar air heating
Fan modification	Ventilation fans
Efficient exhaust fans	Employ solar air heating
Modify building reflection	Building insulation
Low- emittance windows	
<b>Motor Systems</b>	
Motor management plan	Strategic motor selection
Maintenance	Properly sized motors
Motor automation	Adjustable-speed drives
Power factor correction	Minimizing voltage unbalances
<b>Compressed Air Systems</b>	
Maintenance	Monitoring
Leak reduction	Turning off unnecessary compressed air
Modification of system in lieu of increased pressure	Replacement of compressed air by other sources
Improved load management	Use air at lowest possible pressure
Pressure drop minimization	Inlet air temperature reduction
Controls	Properly sized regulators
Properly sized pipe diameters	System improvements
Heat recovery	
<b>Pumps</b>	
Pump system maintenance	Pump system monitoring
Pump demand reduction	Controls
High-efficiency pumps	Properly sized pumps
Multiple pumps for variable loads	Impeller trimming
Avoiding throttling valves	Replacement of belt drives
Proper pipe sizing	Adjustable-speed drives
<b>Hot Water and Steam Systems</b>	
<b>Boilers</b>	
Boiler process control	Reduction of flue gas quantities
Reduction of excess air	Properly sized boiler systems
Improved boiler insulation	Boiler maintenance
Flue gas heat recovery	Condensate return
Blow down steam recovery	Boiler replacement

<b>Steam Distribution Systems</b>	
Improved distribution system insulation	Insulation maintenance
Steam trap improvement	Steam trap maintenance
Steam trap monitoring	Leak repair
Flash steam recovery	
<b>Chillers</b>	
Raise chilled water temperature	Reduce condenser water temperature
Keep heat transfer surfaces clean	Remove trapped air from the condenser
Use naturally occurring cool water	Load management
Heat recovery	Absorption chillers
Use high-efficiency mechanical chillers	Optimize auxiliary equipment
<b>Dust Collectors</b>	
Seal areas	Employ minimum effective draft
Automation	Adjustable-speed drives
Maintain the differential pressure	Controls
Efficient cleaning	

**Table 9. Summary of cost efficiency measures specific to concrete production**

<b>Pneumatic Conveying</b>	
Optimum conveying velocity	Size pipe length and bore correctly
Minimize wear	Switch from dilute to dense phase
Switch to mechanical conveying	
<b>Cold Weather Concreting</b>	
Provide shelter	Create sloped and paved areas for the stockpiles
Adjust stockpile height and capacity	Insulate aggregate bins
Process control	Maintain bins and silos
Chose appropriate method for drying	
<b>Humidity Control</b>	
Turn a “dry-batch” into a “wet-batch” plant	Microwave Sensors and automatic control
<b>Mixing</b>	
Optimum mixing time	Mixer type
Increase mixer capacity	Multiple mixing
Cleaning and maintenance	
<b>Truck Operation and Fleet Management</b>	
Track fuel consumption	Reduce idle time
Route optimization	Driver training
Increase load-size coefficient	Preventive maintenance
<b>Curing</b>	
Improve insulation	Detect leaks
Determine preset period	Utilize hydration heat
Period of maximum temperature	Cement type
SCMs	Chemical admixture
Replace autoclaves	Automated curing systems
<b>Returned Concrete</b>	
Excess concrete reduction	Reuse on the plant site
Create precast products	Batch on top
Stoning out	Mechanical concrete reclaimer
Mechanical reclaimer plus HSAs	Crushing and recycling concrete
<b>Process Water</b>	
Multiple low volume drum washouts	Chemical admixtures
Heat the aggregates	Restrain fresh water flow
Shut-off valves	Curbing and gutters
Capture water	Create settlement basins
<b>Miscellaneous</b>	
Streamline raw material handling	Automation in precast
Co-generation	Optimize concrete mix
Self-Consolidating Concrete (SCC)	Concrete pre-cooling method



## **Acknowledgements**

This work was supported by the Climate Protection Partnerships Division of the U.S. Environmental Protection Agency as part of its ENERGY STAR program through the U.S. Department of Energy under Contract No. DE-AC02-05CH11231.

Many people supplied useful comments and suggestions to sections included in this Energy Guide and helped to improve the Energy Guides substantially. We would like to especially thank (in alphabetical order) Chris Bayne (Titan America), Steve Coppinger (California Portland Cement), Elizabeth Dutrow (U.S. Environmental Protection Agency), Greg Harrell (Energy Management Services), Don Hertkorn (ICF International), Rebecca Hindin (U.S. EPA), Gunnar Hovstadius (Gunnar Hovstadius Consulting, LLC), Ted Jones (CEE), John Malinowski (Baldor Electric Company), Ilene Mason (CEE), Aimee McKane (LBNL), Gary Mullings (National Ready Mixed Concrete Association), Fred Schoeneborn (FSC), and Walt Tunnessen (U.S. EPA). Any remaining errors in this Energy Guide are the responsibility of the authors. The views expressed in this Energy Guide do not necessarily reflect those of the U.S. Environmental Protection Agency, the U.S. Department of Energy, or the U.S. government.

## **Glossary**

AC	Alternating current
ACI	American Concrete Institute
ASD	Adjustable-speed drive
ASTM	American Society for Standards and Materials
ATA	American Trucking Association
BFS	Blast Furnace Slag
Btu	British thermal unit
CAC	Compressed Air Challenge <sup>®</sup>
CAD	Computer Aided Drawing
CCA	Crushed Concrete Aggregate
CDP	Concrete Delivery Professional
CEE	Consortium for Energy Efficiency
CFL	Compact fluorescent lamp
CHP	Combined heat and power
CIPEC	Canadian Industry Program for Energy Conservation
CMU	Concrete Masonry Unit
CO	Carbon monoxide
CO <sub>2</sub>	Carbon dioxide
CPBM	Concrete Plants Manufacturers Bureau
CRI	Color Rendering Index
cu.yd	Cubic yard
CWSAT	Chilled Water System Analysis Tool

EASA	Electrical Apparatus Service Association
EIA	Energy Information Administration
EPAct	Energy Policy Act
FEMP	Federal Energy Management Program
<i>fib</i>	Fédération Internationale du Béton
ft	Feet
ft <sup>2</sup>	Square feet
ft <sup>3</sup>	Cubic feet
GHGs	Greenhouse gases
GJ	Gigajoule
GPS	Global Positioning System
HID	High-intensity discharge
HPC	High Performance Concrete
hp	Horsepower
HRWR	High Range Water Reducer
HSA	Hydration Stabilizing Admixture
HVAC	Heating, ventilation, and air conditioning
IAC	Industrial Assessment Center
ISO	International Organization of Standardization
kBtu	Thousand British Thermal Unit
kg	Kilogram
kW	Kilowatt
kWh	Kilowatt hour

lb	Pound
LBNL	Lawrence Berkeley National Laboratory
LCC	Life cycle costing
LED	Light emitting diode
LN	Liquid Nitrogen
LPG	Liquefied petroleum gas
MBtu	Million British thermal units
m	Meter
m <sup>3</sup>	Cubic meters
MJ	Megajoule
mm	Millimeter
mpg	miles per gallon
NEMA	National Electrical Manufacturers Association
NO <sub>x</sub>	Nitrogen oxides
NRMCA	National Ready Mixed Concrete Association
PCA	Portland Cement Association
PCI	Precast/Prestressed Concrete Institute
pH	Potential of Hydrogen
psi	Pounds per square inch
psig	Pounds per square inch gauge
PTO	Power-take-off
RMC	Ready Mixed Concrete
SCC	Self-Consolidating Concrete or Self-Compacting Concrete

SCMs	Supplementary Cementitious Materials
SRP	Soil Retention Products
TBtu	Trillion British Thermal Units
U.S. DOE	United States Department of Energy
U.S. EPA	United States Environmental Protection Agency
USGS	United States Geological Survey
VFD	Variable frequency drive
yd	Yard
yd <sup>2</sup>	Square yard
yd <sup>3</sup>	Cubic yard

## References

- American Concrete Institute (ACI) Committee 305. 1991. Hot Weather Concreting. Farmington Hills, Michigan. ACI 305R-91.
- American Concrete Institute (ACI) Committee 517. 1992. Accelerated Curing of Concrete at Atmospheric Pressure-State of the Art . Farmington Hills, Michigan. ACI 517.2R-87.
- American Concrete Institute (ACI) Committee 207. 1993. Cooling and Insulating Systems for Mass Concrete. Farmington Hills, Michigan. ACI 207.4R-93.
- American Concrete Institute (ACI) Committee 306. 2002. Cold Weather Concreting. Farmington Hills, Michigan. ACI 306R-2.
- American Society for Testing and Materials (ASTM) C94. Standard Specification for Ready Mixed Concrete. West Conshohocken, Pennsylvania.
- American Society for Testing and Materials (ASTM) C 1602. Standard Specification for Mixing Water Used in the Production of Hydraulic Cement Concrete. West Conshohocken, Pennsylvania.
- American Society for Testing and Materials (ASTM) C 1603. Standard Test Method for the Measurement of Solids in Water. West Conshohocken, Pennsylvania.
- Ang, B. W., T. F. Fwa, T. T. Ng. 1993. "Analysis of Process Energy Use of Asphalt-Mixing Plants." *Energy*, 18 (7), pp.769-777.
- American Trucking Associations (ATA). 2008a. Idling Reduction. <http://www.truckline.com/advisories/environment/pages/idlingreduction.aspx>
- Argeles, C., M. Intrator, W. Twitty, M. Armor. 2010. *Sustainable Concrete Plant Guidelines, Pilot-Version*. Prepared for the RMC Research and Education Foundation.
- ASHRAE. 2005. *2005 ASHRAE Handbook: Fundamentals*. ASHRAE: Atlanta, GA.
- Athena Sustainable Materials Institute. 1993. *Raw Material Balances, Energy profiles and Environmental Unit Factor Estimates: Cement and Structural Concrete Products*. Prepared by Canada Centre for Mineral & Energy Technology and Radian Canada Inc., Ottawa, Canada.
- Atkinson, W. 2010. "Cost Management Strategies that Work." *Precast Inc. Magazine*. 28 August 2010. <http://precast.org/precast-magazines/2010/05/cost-management-strategies-that-work/>
- Bartholomew, L., J. Hilbet. 1984. A Look at the Power and Energy Considerations of various Kiln Feeding System Alternatives.
- Bayne, C. 2011. Titan America. Personal Communication.
- Beaver, W. 2004. "Liquid Nitrogen for Concrete Cooling." *Concrete International*, 26(9) pp. 93-95. [http://concreteinternational.com/pages/featured\\_article.asp?FromSearch=True&keywords=liquid+nitrogen+for+concrete+cooling&srctype=ALL&ID=13374](http://concreteinternational.com/pages/featured_article.asp?FromSearch=True&keywords=liquid+nitrogen+for+concrete+cooling&srctype=ALL&ID=13374)

- Beckham, D.J. No date. Knelson Concrete Recovery System. <http://www.p2pays.org/ref/19/18264.pdf>
- BIBKO. 2011. Concrete Reclaiming System. <http://www.bibko.us/>
- Biege, N. W., L. C., Bartholomew, L. J. DiBuo. 1998. “New Techniques to Improve and Modify Existing Pneumatic Conveying Systems in Cement Plants” *Proc. 1998 IEEE-PCA Cement Industry Technical Conference, 40<sup>th</sup> Conference Record*, pp. 177-187.
- Borger, J., R. L. Carasquillo, D. W. Fowler. 1994. “Use of Recycled Use water and Returned Plastic Concrete in the Production of Fresh Concrete”. *Advanced Cement Based Materials*, 1 (6), pp.267-274.
- Boscolo, A., C. Mangiavacchi, O. Tuzzi. 1993. “Fuzzy Sensor Data Fusion for Quality Monitoring in Concrete Mixing Plant” *Conference Record-IEEE Instrumentation and Measurement Technology Conference*, pp.671-675.
- British Precast. 2006. Sustainability Matters, Second report on the precast industry’s sustainability. December 2006.
- British Precast. 2008. Building Excellence in Precast. Moving the Industry Forward 2008. The British Precast Federation Limited.
- Budny, E., M. Chlosta, H. J. Meyer, M. J. Skibniewski. 2009. “Construction Machinery”. In: K. H. Grote, E. Antonsson, (eds.) *Handbook of Mechanical Engineering*. New York: Springer. Ch. 14.
- Byron, T., B. Ivery, J. Flaherty. 2004. *Concrete Batch Plant Operator. Study Guide*. Developed by the Florida Department of Transportation.
- Campbell, J. 2008. Think You Are Achieving Your Heat Recovery Potential? Enercase, Condensate and Flue Gas Heat Recovery.
- Canadian Industry Program for Energy Conservation (CIPEC). 2001a. Blue Circle Cement Fires Up Energy savings at Ontario Plants. *Heads Up CIPEC Newsletter*, 5 (21), pp. 1-2. Published by Office of Energy Efficiency, Natural Resources Canada, Ottawa, ON, Canada.
- Canadian Industry Program for Energy Conservation (CIPEC). 2001b. *Boilers and Heaters, Improving Energy Efficiency*. Natural Resources Canada, Office of Energy Efficiency, Ottawa, Ontario. August.
- Canadian Industry Program for Energy Conservation (CIPEC). 2011. New Cement-Curing System at Groupe Permacon Yields Interesting Natural gas Savings. *Heads Up CIPEC Newsletter*. January 15, (XV/2). Office of Energy Efficiency, Natural Resources Canada, Ottawa, ON, Canada.
- Carew, J., T. Green, A. Benjamin, P. Moore, G. M. Mullings. 2007. Report of: 2007 National Ready Mixed Concrete Association Fleet Benchmarking and Costs Survey. *Concrete In Focus*, pp. 11-30. Fall 2007. [http://www.nrmca.org/news/connections/Fall\\_2007.pdf](http://www.nrmca.org/news/connections/Fall_2007.pdf)
- Carter, J. and Troyano-Cuturi, K. 2011. Capsule Pipelines for Aggregate Transport: Economics. Department of Earth Science and Engineering. Imperial London College. <http://www3.imperial.ac.uk/earthscienceandengineering/research/energyenvmodmin/capsule/economics>
- Cazacliu, B. G., P. O. Vandanjon, F. De Lallard, D. Chopin. 2002. “Current Issues in Concrete Mixing Research”. In: Dhir, R. K., Hewlett, P. C., Csetenyi, L. J.(eds.), *Proceedings of the International*

*Conference: Innovations and Developments in Concrete Materials and Construction*, Dundee, September, pp.837-847.

Cazacliu, B. and Ventura, A. 2010. "Technical and Environmental Effects of Concrete Production: dry batch versus central mixed plant". *Journal of Cleaner Production*, 18, pp.1320-1327.

Chang, P. K., Y.N. Peng. 2001. "Influence of Mixing Techniques on Properties of High Performance Concrete." *Cement and Concrete Research*, 31 (1), pp. 87-95.

Choate, W. T., 2003. *Energy and Emission Reduction Opportunities for the Cement Industry*. Prepared for the Industrial Technologies Program. U.S Department of Energy, Energy Efficiency and Renewable Energy.

Chopin, D., B. Cazacliu, F. De Larrard, R. Schell. 2007. "Monitoring of Concrete Homogenisation with the Power Consumption Curve." *Materials and Structures*, 40, pp.897-907.

Concrete Plants Manufacturers Bureau (CPBM). 2007. Concrete Plant Standards of the Concrete Plant Manufacturers Bureau. CPBM 100-07, 15<sup>th</sup> revision.

Consortium for Energy Efficiency (CEE). 2007. Energy-Efficiency Incentive Programs: Premium-Efficiency Motor & Adjustable Speed Drives in the U.S. and Canada. Boston, Massachusetts. May.

Coppinger, S. 2011. California Portland Cement. Personal Communication

CREST. 2001. Solar Thermal Catalog—Chapter 5.2: Ford Motor Company/ Chicago Stamping Plant. [http://solstice.crest.org/renewables/seia\\_slrthrm/52.html](http://solstice.crest.org/renewables/seia_slrthrm/52.html).

Division of Pollution Prevention and Environmental Assistance (DPPEA). 1995a. Case Study: Watauga Ready Mix Corporation. SIC 3300 Case Studies.

Division of Pollution Prevention and Environmental Assistance (DPPEA). 1995b. Concrete Manufacturer Reduces Water Use and Solid Waste. Minnesota Technical Assistance Program. Case Study.

Dominion (no date). Lighting Rewards. <http://www.dom.com/dominion-virginia-power/customer-service/energy-conservation/pdf/va-lighting-rewards-rebate-chart.pdf>

Downs, D. 2009. Fleet Truck Idle Time Reduction Initiative. Titan America. ENERGY STAR Focus on Energy Efficiency in Cement Manufacturing. November 2009.

Electric Apparatus Service Association (EASA). 2003. *The Effect of Repair/Rewinding on Motor Efficiency*. St. Louis, Missouri.

Electric Apparatus Service Association (EASA). 2006. ANSI/EASA Standard AR100-2006. Recommended Practice for the Repair of Rotating Electrical Apparatus. St. Louis, Missouri.

Energy Information Administration (EIA). 2010. Average Prices of Purchased Energy Sources, 2006.

Energy Information Administration (EIA). 2011a. STEO Table Browser. U.S. Energy Prices. [http://www.eia.gov/emeu/steo/pub/cf\\_tables/steotables.cfm?tableNumber=8](http://www.eia.gov/emeu/steo/pub/cf_tables/steotables.cfm?tableNumber=8)



Energy Information Administration (EIA). 2011b. Monthly Energy Review June 2011. Washington, D.C. DOE/EIA-0035.

Fédération Internationale du Béton (*fib*). 2003. Environmental Issues in Prefabrication. Lausanne. ISBN 978-2-88394-061-1.

Fédération Internationale du Béton (*fib*). 2004. Environmental design: State-of-art report. Lausanne. ISBN 978-2-88394-068-0.

Fenning, L. et al. (Eds.) 2001. *Pump Life Cycle Costs: A Guide to LCC Analysis for Pumping Systems*. Hydraulic Institute/Europump/ United States Department of Energy. ISBN: 1-880952-58-0.

Ferraris, C. F. 2001. "Concrete Mixing Methods and Concrete Mixers: State of the Art." *Journal of Research of the National Institute of Standards and Technology*, 106, pp.391-399.

French C., A. Mokhtarzadeh, T. Ahlborn, R. Leon. 1998. "High-Strength Concrete Applications to Prestressed Bridge Girders." *Construction and Building Materials*, 12, pp.105-113.

Griffin, B. 2000. "The Enbridge Consumers Gas "Steam Saver" Program." *22nd National Industrial Energy Technology Conference Proceedings*. Houston, Texas. April 5-6: pp. 203-213.

Grünewald S., L. Ferrara, F. Dehn. 2010. "Structural Design with Flowable Concrete"- A *fib*-Recommendation for Tailor-Made Concrete. *Proceedings of SCC2010, Design Production and Placement of Self-Consolidating Concrete*. Khayat K. H. and Feys, D. (Eds.). pp. 13-23.

Herbert E. 2006. "Water, Water Everywhere, Maybe Not? Maybe \$\$\$?." *Concrete Infocus* (Winter 2006). <http://www.nrmca.org/news/connections/2005.asp>

Hester, W.T., 1978. "High-Range Water-Reducing Admixtures in Precast Concrete Operations." *PCI Journal*, July-August, 1978, pp.68-85.

Hydronix, Ltd. 2005. "Moisture Measurement for Rotating Pan Mixers." *Concrete Technology, Concrete Plant International (CPI) Journal*, August, 2005. pp. 88-95. <http://www.cpi-worldwide.com/>

Hydronix. 2006. Cement Savings Spreadsheet. <http://www.hydronix.com/downloads/products.asp>

ICF Consulting Canada Inc. 2002. *Multi-Pollutant Emission Reduction Analysis Foundation (MERAf) for the Canadian Ready – Mixed Concrete Sector*. Project No: K2219-1-0007.

Industrial Assessment Center (IAC). 2010. Industrial Assessment Center Database Version 10.0. <http://iac.rutgers.edu/database/recommendations/>

International Organization of Standardisation (ISO) 18650-1. 2004. Building Construction Machinery and Equipment. Concrete Mixers. Part 1: Terminology and Commercial Specifications,"Gneva 2004.

Johansson, A. 1971. The Relationship between mixing time and the type of concrete mixer, *Natl. Swed. Build. Res. Summaries T1*: 1971.

Joint Service Pollution Prevention 2003. Concrete/Asphalt Crushers. [http://www.p2sustainabilitylibrary.mil/p2\\_opportunity\\_handbook/7\\_III\\_6.html](http://www.p2sustainabilitylibrary.mil/p2_opportunity_handbook/7_III_6.html)

- Jones, T., M. Zagula, J. Hinkle, B. Mobley, G. Mullings. 2010. "2010 National Ready Mixed Concrete Association (NRMCA) Fleet Benchmarking and Cost Surveys." *Concrete InFocus*, pp. 7-13. September/October 2010. <http://www.nxtbook.com/nxtbooks/naylor/NRCS0410/index.php#/0>
- Juenger, M. C. G., J. Hema, S. Solt. 2007. *The Effects of Liquid Nitrogen on Concrete Properties*. Texas Department of Transportation. 0-5111-1.
- Kawai, K., T. Sugiyama, K. Kobayashi, S. Sano. 2005. "Inventory Data and Case Studies for Environmental Performance Evaluation of Concrete Structure Construction." *Journal of Advanced Technology*, 3 (3), pp. 435-456.
- Khurana R., R. Magarotto, I. Torresan. 2002. "New Generation of Polycarboxylate Superplasticizer to Eliminate Steam Curing of Concrete." In: R. K. Dhir, P. C. Hewlett, L. J. Csetenyi. Eds. *Innovations and Developments in Concrete Materials and Construction*. London: Thomas Telford Publishing.
- Klinzing, G. E., F. Rizk, R. Marcus, L. S. Leung. 2010. *Pneumatic Conveying of Solids, A Theoretical and Practical Approach*. 3rd ed. New York: Springer.
- Kraft Energy Systems Inc. 2010. "Internal Plant Assessment Results in Higher Plant Efficiency and Better Product Quality." *Concrete Plant International (CPI) Journal*, January, pg.112-115. <http://www.cpi-worldwide.com/>
- Lee, M. 1989. "Economical Cooling of Hot Weather Concrete." *Concrete Construction*, pp.791-796. <http://www.concreteconstruction.net/concrete-articles/economical-cooling-of-hot-weather-concrete.aspx>
- Lobo C., and Mullings G. M. 2003. "Recycled Concrete in Ready Mixed Concrete Operations." *Concrete In Focus*, National Ready Mixed Association, Spring. [http://www.nrmca.org/research\\_engineering/Articles.htm#2003\\_AND\\_EARLIER](http://www.nrmca.org/research_engineering/Articles.htm#2003_AND_EARLIER)
- Lobo, C.L. and Gaynor, R.D. 2006. "Ready Mixed Concrete." In: J. F. Lamond & J. H. Pielert (Eds.), *Significance of Test and Properties of Concrete and Concrete Making-Materials*, STP169D, pp. 533. West Conshohocken, United States: International Standard Worldwide.
- Lowke, D., P. Schiessl. No date. Effect of Mixing Energy on Fresh Properties of SCC. Technical University of Munich.
- Mak, S. L. 1998. "Thermal Reactivity of Slag Cement Binders and the Response of high Strength Concretes to In-Situ Curing Conditions." *Materials and Structures*, 33, pp.29-37.
- Marceau, M. L., M. A. Nisbet, M. G. VanGeem. 2007. *Life Cycle Inventory of Portland Cement Concrete*, SN3011, Portland Cement Association (PCA), Skokie, Illinois.
- Marcus, R. D. 1985. *Cement Discharge-Anglo Alpha Cement*, internal report, University of Witwatersrand, Johannesburg, Materials Handling Research Unit.
- Masanet, E., E. Worrell, W. Graus, C. Galitsky. 2008. *Energy Efficiency Improvement and Cost Saving Opportunities for the Fruit and Vegetable Processing Industry - An ENERGY STAR® Guide for Energy and Plant Managers*. Berkeley, California: Lawrence Berkeley National Laboratory (LBNL-59289-Revision).

Mc Craven, S. No date. Precast Concrete Offers Achievable Solutions for Specifiers and Producers. Precast Solutions. <http://www.solutions.precast.org/precast-concrete-sustainability-case-study>

Millennium EMS Solutions Ltd. (MEMS). 2010. *Guide to the Code of Practice for the BC Concrete and Concrete Products Industry*. Version 6. BC Ready Mixed Concrete Association.

Mills, D. 2004. *Pneumatic Conveying Design Guide*. 2<sup>nd</sup> ed. Amsterdam: Elsevier.

Motor Decisions Matter (MDM). 2007. *Motor Planning Kit*. Boston, Massachusetts. [www.motorsmatter.org/tools/mpkv21.pdf](http://www.motorsmatter.org/tools/mpkv21.pdf).

Mullings, G. 2011. National Ready Mixed Concrete Association (NRMCA). Personal Communication.

Myer, M., M. L. Paget, et al. (2009). Performance of T12 and T8 Fluorescent Lamps and Troffers and LED Linear Replacement Lamps CALiPER Benchmark Report: Medium: ED; Size: PDFN. Report # PNNL-18076; Other: BT0301000

National Electrical Manufacturers Association (NEMA). 2001. *NEMA Standards Publication No. MG-10 2001, Energy Management Guide For Selection and Use of Fixed Frequency Medium AC Squirrel-Cage Polyphase Induction Motors*. Rosslyn, Virginia.

National Electrical Manufacturers Association (NEMA). 2002. *NEMA Standards Publication No. MG-1, Motors and Generators, Revision 3*. Rosslyn, Virginia.

National Ready Mixed Concrete Association (NRMCA), 2008. The Ready Mixed Concrete Industry: An Integral Part of the American Economy. [http://www.nrmca.org/advocacy/documents/rmc\\_industry\\_factsheet\\_08.pdf](http://www.nrmca.org/advocacy/documents/rmc_industry_factsheet_08.pdf)

National Ready Mixed Concrete Association (NRMCA). 2011. About Concrete Industry Production Statistics. <http://www.nrmca.org/concrete/data.asp>

National Ready Mixed Concrete Association (NRMCA). 2011a. "2010 Quality Benchmarking Survey." *Concrete InFocus*, pp. 11-15. January/February 2011. <http://www.nrmca.org/news/connections/JanFeb2011.pdf>

National Ready Mixed Concrete Association (NRMCA). 2011b. Production of Ready Mixed Concrete. <http://www.nrmca.org/aboutconcrete/howproduced.asp>

Nielsen, C. V., M. Glavind. 2007. Danish Experiences with a Decade of Green Concrete. *Journal of Advanced Concrete Technology*. 5 (1), pp. 3-12.

Nisbet, M., M. G. VanGeem, J. Gajda, M. Marceau. 2000. *Environmental Life Cycle Inventory of Portland Cement Concrete*. Portland Cement Association (PCA). PCA R& D Serial No.2137.

Obara, T., X. An, F. Jin. No date. Environmental Impact Evaluation of a New Type of Continuous Mixing Plant for Dam Constructions. Tsinghua University.

Obla, K., F. Rodriguez, S. B. Barka. 2005. "Experimental Case Study Demonstrates Advantages of Performance Specifications." *Concrete inFocus*, pp. 32- 42. Summer 2005. [http://www.nrmca.org/news/connections/Summer\\_2005.pdf](http://www.nrmca.org/news/connections/Summer_2005.pdf)

- Obla, K., Kim, H., Lobo, K. 2007. *Crushed Returned Concrete as Aggregates for New Concrete*. Final Report of the RMC Research and Education Foundation. Project 05-13.
- Olivarri, M.J. 2011. "Highlights of the 2010 NRMCA Industry Data Survey, (Analysis of 2009 data)." *Concrete InFocus*, pp. 19-22. January/February 2011. <http://www.nrmca.org/news/connections/JanFeb2011.pdf>
- Ortwein, H. 2005. "Energy management in Precast Concrete Plant- A Way to Increase Profits." *Concrete Plants International (CPI) Journal*. August 2005. pp. 100-105. <http://www.cpi-worldwide.com/>
- Van Oss, H. G. 2005. "2005 Minerals Yearbook, Cement." U.S. Geological Survey-Minerals Yearbook. Washington D.C. United States Geological Survey (USGS). <http://minerals.usgs.gov/minerals/pubs/commodity/cement/>
- Van Oss, H. G. 2011. Mineral Commodity Summary - Cement. Washington D.C. United States Geological Survey (USGS), pg 38-40, <http://minerals.usgs.gov/minerals/pubs/commodity/cement/>
- Van Oss, H. G. various years. "Minerals Yearbook, Cement." U.S. Geological Survey-Minerals Yearbook. Washington D.C. United States Geological Survey (USGS). <http://minerals.usgs.gov/minerals/pubs/commodity/cement/>
- Ouchi, M., S. Nakamura, T. Osterberg, S. E. Hallberg, M. Lwin. 2003. "Applications of Self-Compacting Concrete in Japan, Europe and the United States." In *3<sup>rd</sup> International Symposium on High Performance Concrete, PCI National Bridge Conference Proceedings*. October 19-22, 2003. Orlando.
- Paolini M., R. Khurana. 1998. "Admixtures for Recycling of Waste Concrete." *Cement and Concrete Composites*. 20, pp. 221-229.
- Portland Cement Association (PCA). 2002. "Chapter 14 Cold-Weather Concreting," IS154, *Design and Control of Concrete Mixtures*. EB001.
- Portland Cement Association (PCA). 2011a. Concrete Design and Production. [http://www.cement.org/tech/cct\\_concrete\\_prod.asp](http://www.cement.org/tech/cct_concrete_prod.asp)
- Portland Cement Association (PCA). 2011b. Prestressed Concrete. [http://www.cement.org/basics/concreteproducts\\_prestressed.asp](http://www.cement.org/basics/concreteproducts_prestressed.asp)
- Precast/Prestressed Concrete Institute (PCI) 1997. *Bridge Design Manual*. MNL-133-97.
- Precast/Prestressed Concrete Industry (PCI) Interim SCC Guidelines FAST Team. 2003. *Interim Guidelines for the Use of Self-Consolidating Concrete in Precast/Prestressed Concrete Institute Member Plants*. 1<sup>st</sup> edition. TR-6-03.
- Ramachandran, V. S. ed. 1996. *Concrete Admixtures Handbook. Properties Science and Technology*. 2<sup>nd</sup> ed. New Jersey: Noyes Publications.
- Reinecke, H. 2010. New Technology of Water Treatment and Two-Step Mixing of Concrete. Ready Mixed Concrete. [http://www.fmlconcretec.de/download/FML\\_CONCRETE\\_01\\_2010.pdf](http://www.fmlconcretec.de/download/FML_CONCRETE_01_2010.pdf)
- Rejeb, S. K. 1995. "Technique of Multi-Step Concrete Mixing." *Material and Structures*. (28), pp.230-234.

- Rejeb, S. K. 1996. "Improving Compressive Strength of Concrete by a Two-Step Mixing Method." *Cement and Concrete Research*, 26, pp.585-592.
- Rupnow, T. D., V. R. Schaefer, K. Wang, B. L. Hermanson. 2007. *Improving Portland Cement Concrete Mix Consistency and Production Rate Through Two-Stage Mixing*. National Concrete Pavement Technology Center.
- Schießl, P., O. Mazanec, D. Lowke. 2007. "SCC and UHPC – Effect of Mixing Technology on Fresh Concrete Properties." *Advances in Construction Materials*, (VI), pp.513-522.
- Sealey, B. J., P. S. Philips, G. J. Hill. 2001. "Waste Management Issues for the UK Ready- Mixed Concrete Industry." *Resources Conservation and Recycling*, 32, pp.321-331.
- Shepherdson, R. 2010. "Selecting the Best Mixer for your Application. Concrete Technology. Production Optimization." *CPI Concrete Plant International (CPI) Journal Industry*. March, 2010 pp. 22-25. <http://www.cpi-worldwide.com/>
- Shutt, C.A. 2002. "Self Compacting Concrete Offers Design Potential." *Ascent Magazine*. Precast/Prestressed Concrete Industry (PCI). Winter 2002, pp.20-23. <http://pci.org/publications/ascent/index.cfm>
- Simmons, G. H. No date. Stockpiles. Technical Paper T-128. <http://www.astecinc.com/>
- Smith, A. 1990. Water-Source Heat Pump Economically Controls Concrete Temperature. Concrete Construction. <http://www.concreteconstruction.net/geothermal-systems/water-source-heat-pump-economically-controls-conc.aspx>
- Stamper, G., R. L. Koral, C. Strock. 1979. *Handbook of Air Conditioning Heating and Ventilating. Space Heating*. 3<sup>rd</sup> ed. United States of America: Sixth Printing.
- Tam V. W. Y, Tam C. M. 2007. "Economic Comparison of Recycling Over- Ordered Fresh Concrete: A Case Study Approach." *Resources Conservation and Recycling*, 52, pp.208-218.
- Tetley, P. A. 2001. "Cutting Energy Costs with Laboratory Workstation Fume Hood Exhaust." *Pharmaceutical Engineering* 21 (5), pp. 90–97.
- Thissen, G. J., D. L. Schott, E. W. Demmink, G. Lodewijks. 2010. "Reducing Drying Energy and Costs by Process Alterations at Aggregate Stockpiles." *Energy Efficiency*, 4 (2), pp. 223-233.
- Today's Concrete Technology. 2010. Precast Plant Automation. <http://www.todaysconcretetechnology.com/precast-plant-automation.html>
- Unites States Census. 1995. Statistics for Industry Groups and Industries: 1993. Annual Survey of Manufactures. United states Census Bureau, Washington, D.C. Report #M93(AS)-1.
- Unites States Census. 1996. Statistics for Industry Groups and Industries: 1994. Annual Survey of Manufactures. United states Census Bureau, Washington, D.C. Report #M94(AS)-1.
- Unites States Census. 1997. Statistics for Industry Groups and Industries: 1995. Annual Survey of Manufactures. United states Census Bureau, Washington, D.C. Report #M95(AS)-1.

United States Census. 1998. Statistics for Industry Groups and Industries: 1996. Annual Survey of Manufactures. United States Census Bureau, Washington, D.C. Report #M96(AS)-1.

United States Census. 2002. Statistics for Industry Groups and Industries: 2000. Annual Survey of Manufactures. United States Census Bureau, Washington, D.C. Report# M00(AS)-1.

United States Census. 2006. Statistics for Industry Groups and Industries: 2005. Annual Survey of Manufactures. United States Census Bureau, Washington, D.C. Report# M05(AS)-1.

United States Census. 2009. 2007 Economic Census. Manufacturing: Industry Series: Detailed Statistics by Industry for the United States: 2007. <http://factfinder.census.gov/>

United States Census, 2010. Annual Survey of Manufactures Data: 2009 and 2008, Department of Commerce, Washington, D.C. Available online at: <http://factfinder.census.gov/>

United States Department of Energy (DOE). 2001. *Pump Life Cycle Costs: A Guide to LCC Analysis for Pumping Systems*. Office of Industrial Technologies, Washington, D.C. Report DOE/GO-102001-1190.

United States Department of Energy (DOE). 2003. Lehigh Cement Southwest Company: Compressed Air System Improvement Saves Energy at a Lehigh Southwest Cement Plant. Best Practices, Case Study. Office of Energy Efficiency and Renewable Energy, Industrial Technologies Program, Washington D.C.

United States Department of Energy (DOE). 2005. CEMEX: Cement Manufacturer Saves 2.1 kWh Annually with a Motor Retrofit Project. Office of Energy Efficiency and Renewable Energy, Industrial Technologies Program, Washington, D.C.

United States Department of Energy (DOE). 2006a. *Improving Pumping System Performance, A Sourcebook for Industry*. Office of Energy Efficiency and Renewable Energy, Industrial Technologies Program, Washington, D.C. Report DOE/GO-102006-2079.

United States Department of Energy (DOE). 2006b. *Save Energy Now in Your Steam Systems*. Office of Energy Efficiency and Renewable Energy, Industrial Technologies Program, Washington, D.C. Report DOE/GO-102006-2275.

United States Department of Energy (DOE) (2011a). Natural Gas Navigator: Prices. Energy Information Administration, Washington, D.C. <http://www.eia.gov/naturalgas/reports.cfm?t=66>

United States Department of Energy (DOE) (2011b). Petroleum and Other Liquids Navigator: Prices. Energy Information Administration, Washington, D.C. <http://www.eia.gov/petroleum/reports.cfm?t=66>

United States Department of Energy (DOE) and Compressed Air Challenge (CAC) (2003). *Improving Compressed Air System Performance - A Sourcebook for Industry*. Office of Industrial Technologies, Washington, D.C.

United States Department of Energy, Energy Efficiency and Renewable Energy (DOE). 2008. *Improving Motor and Systems Performance: A Sourcebook for Industry*. Office of Energy Efficiency and Renewable Energy, Washington, D.C.

United States Department of Energy, Energy Efficiency and Renewable Energy (DOE). 2010. *Operations and Maintenance Best Practices, A guide to Achieving Operational Efficiency, release 3.0*. Office of Energy Efficiency and Renewable Energy, Washington, D.C.

United States Department of Energy Information Administration (U.S. DOE- EIA). 2011. *Electric power Annual 2009*. Washington DC: U.S. DOE- EIA.

United States Department of Transportation Federal Highway Administration. 2011. Superplasticizers. <http://www.fhwa.dot.gov/infrastructure/materialsgrp/suprplz.htm>

United States Environmental Protection Agency (U.S. EPA). 2004. Compilation of Air-Pollutant Emission Factors, AP-42, 5<sup>th</sup> edition, Volume 1: Stationary Point and Area Sources.

United States Environmental Protection Agency (U.S. EPA). 2006. *Teaming Up to Save Energy*. United States Environmental Protection Agency Climate Protection Division, Washington, D.C. Report 430-K-05-007.

United States Environmental Protection Agency (U.S. EPA). 2008. *ENERGY STAR Building Upgrade Manual (2008 Edition)*. Office of Air and Radiation, Washington, D.C. Download from: [www.energystar.gov/index.cfm?c=business.bus\\_upgrade\\_manual](http://www.energystar.gov/index.cfm?c=business.bus_upgrade_manual).

Vickers, G. 2009. “2008 (10<sup>th</sup> annual) Fleet Benchmarking and Cost Survey Report”. Concrete In Focus, pp. 6-8. January/February 2009. [http://www.nrmca.org/news/connections/jan\\_feb\\_09.pdf](http://www.nrmca.org/news/connections/jan_feb_09.pdf)

Virginia Department of Transportation (VDOT). 2011. Chapter IV- Sampling and Control of Hydraulic Cement Concrete. <http://www.virginiadot.org/business/resources/Materials/bu-mat-MOI-IV.pdf>

Walas, M. 1990. *Chemical Process Equipment, Selection and Design*. United States: Elsevier.

Wang, K. and Hu, J. 2005. “Use of a Moisture Sensor for Monitoring the Effect of Mixing Procedure on Uniformity of Concrete Mixtures.” *Journal of Advanced Concrete Technology*, 3(3), pp.371-383.

Zeitz, Ronald A. (Ed.). 1997. *CIBO Energy Efficiency Handbook*. Council of Industrial Boiler Owners, Burke, Virginia.

## Appendix A: ENERGY STAR Energy Management Matrix

The U.S. EPA has developed guidelines for establishing and conducting an effective energy management program based on the successful practices of ENERGY STAR partners.

These guidelines, illustrated in the graphic, are structured on seven fundamental management elements that encompass specific activities.

This assessment matrix on the following page is designed to help organizations and energy managers compare their energy management practices to those outlined in the Guidelines for Energy Management. The full guidelines can be viewed on the ENERGY STAR website at

[www.energystar.gov/index.cfm?c=guidelines.guidelines\\_index](http://www.energystar.gov/index.cfm?c=guidelines.guidelines_index).

### How To Use The Assessment Matrix

The matrix outlines the key activities identified in the ENERGY STAR Guidelines for Energy Management and three levels of implementation:

- Where there is no evidence
- Where some elements of a program are in place
- Where an energy management program is fully implemented

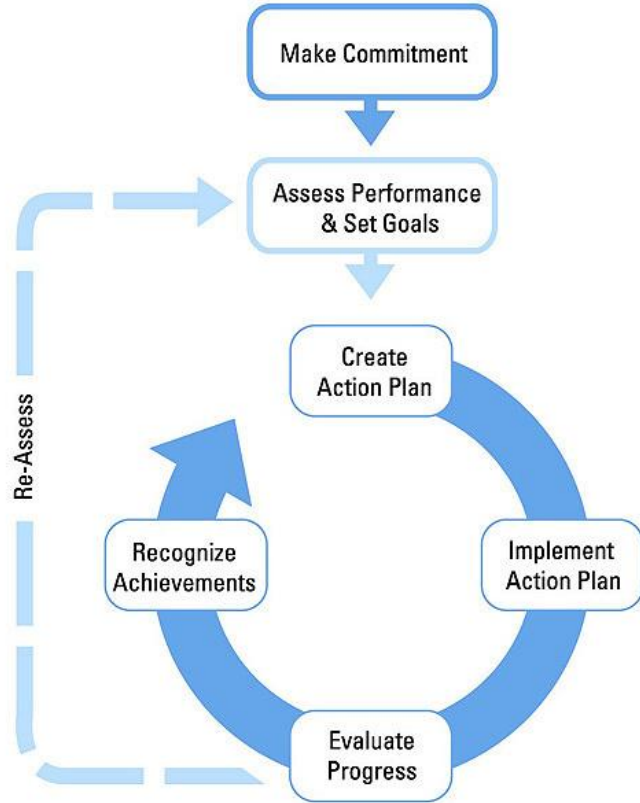

To use apply this tool to your organization, follow these steps:

1. Print the assessment matrix.
2. Compare your program to the guidelines by identifying the degree of implementation that most closely matches your organization's program.
3. Use a highlighter to fill in the cell that best characterizes the level of implementation of your program. You will now have a visual comparison of your program to the elements of the ENERGY STAR Guidelines for Energy Management.
4. Identify the steps needed to fully implement the energy management elements and record these in the Next Steps column.





# ENERGY STAR<sup>®</sup> Facility Energy Management Assessment Matrix

Company Name:		Assessment Date:		
	<b>Little or no evidence</b>	<b>Some elements/degree</b>	<b>Fully implemented</b>	<b>Next Steps</b>
<b>Commit to Continuous Improvement</b>				
<b>Site Energy Leader</b>	None assigned.	Assigned responsibilities but not empowered. 20-40% of time is devoted to energy.	Recognized and empowered leader having site manager and senior energy manager support.	
<b>Site Energy Champion</b>	None identified.	Senior manager implicitly supports the energy program.	Senior manager actively supports the energy program and promotes energy efficiency in all aspects of site operations.	
<b>Site Energy Team</b>	No site energy team.	Informal organization with sporadic activity.	Active cross-functional team guiding site energy program.	
<b>Energy Policy</b>	No energy policy or awareness of organizational policy.	Organizational policy in place. Little awareness by site energy team and limited application of policy.	Organizational policy supported at site level. All employees aware of goals and responsibilities.	
<b>Site Energy Plan</b>	No written plan.	Informal plan not widely known.	Written formal plan endorsed, distributed, and verified.	
<b>Accountability</b>	No energy budgeting and accountability.	Estimates used for allocating energy budgets.	Key users are metered separately. Each entity has total accountability for their energy use.	
<b>Participation Levels</b>	No reporting of energy performance data internally or involvement in external organizations.	Some participation, sharing, mentoring, and professional memberships. Annual reporting of performance.	Participates in energy network/organizations. Shares best practices/mentors other sites. Reports usage quarterly.	
<b>Assess Performance and Opportunities</b>				
<b>Track &amp; Analyze Data</b>	Limited metering or tracking. No demand analysis or billing evaluation.	Some metering, tracking, analyzing, and reporting. Energy bills verified for accuracy.	Key loads metered, tracked, analyzed, and reported. Facility peak demand analyzed. Adjusts for real-time demand.	
<b>Documentation</b>	No manuals, plans, designs, drawings, specs, etc. for building and equipment available.	Some documentation and records available. Some review of equipment commissioning specs conducted.	Critical building and equipment documentation available and used for load surveys/recommissioning/efficiency goals.	

<b>Benchmarking</b>	Energy performance of systems and facilities not benchmarked.	Limited comparisons of specific functions, or only same-site historical comparisons.	Key systems/sites benchmarked using comparison tools like Portfolio Manager/Energy Performance Indicators.	
<b>Technical Assessments</b>	No formal or external reviews.	Limited review by vendors, location, or organizational and corporate energy managers.	Extensive regular reviews by multi-functional team of internal and external professionals. Full assessment every 5 years.	
<b>Best Practices</b>	None identified.	Ad hoc or infrequent monitoring of trade journals, internal databases, and other facilities' best practices.	Regular monitoring of trade journals, internal databases, and other facilities. Best practices shared and implemented.	
<b>Set Performance Goals</b>				
<b>Goals/Potential</b>	Energy reduction goals not established.	Loosely defined. Little awareness of energy goals by others outside of site energy team.	Potential defined by experience or assessments. Goals roll up to unit/site/organization and status posted prominently.	
<b>Career Development</b>	No career development. No opportunities available.	Exposure to other energy programs. Some temporary or project assignments available elsewhere.	Energy professionals have established career paths that are reviewed annually. Opportunities for growth encouraged.	
<b>Energy Team Incentives</b>	No ties between energy efficiency improvement and compensation.	Spot awards or luncheons for employees on a project.	Accountability tied to performance reviews, compensation, and personal and plant bonuses.	
<b>Create Action Plan</b>				
<b>Improvement Planning</b>	No upgrade plan.	Upgrades implemented sporadically. Some compliance with organizational goals and standards.	Upgrade plans established; reflect assessments. Full compliance with organizational EE design guidelines and goals.	
<b>Roles and Resources</b>	Not addressed, or addressed on ad hoc basis only.	Informal interested person competes for funding. Little support from organizational program.	Internal/external roles defined and funding identified. Organizational or corporate program support secured.	
<b>Site Planning Integration</b>	Impact on energy from changes not considered.	Decisions impacting energy considered on first-cost basis only.	Projects/contracts include energy analysis. Energy projects evaluated with other investments. Lifecycle costing applied.	
<b>Implement Action Plan</b>				
<b>Communication Plan</b>	Site plan not developed.	Periodic communications for projects. Some reporting of energy use information.	All stakeholders are addressed on regular basis.	
<b>Energy Awareness</b>	None conducted.	Occasional energy efficiency awareness campaigns. Some communication of energy costs.	Planned outreach and communications. Support organizational initiatives. Employees aware of site energy costs.	

<b>Building Staff Capacity</b>	No training offered.	Some vendor training for key individuals and operators.	Broad training/certification in technology and best practices. Networking opportunities actively pursued.	
<b>Contract Management</b>	Contracts are renewed automatically without review.	Occasional review of supplier contracts.	Energy-efficient procurement policy in place. Vendors for replacements on standby. Regular review of suppliers.	
<b>Incentives and Rebates</b>	Not researched or pursued.	Occasional communication with utility representatives. Limited knowledge of incentive programs.	Researches rebates and incentives offered regionally and nationally. Communicates often with utility representatives.	
<b>Evaluate Progress</b>				
<b>Measuring Results</b>	No reviews.	Historical comparisons. Some reporting of results.	Compare usage & costs vs. goals, plans, other sites. Results reported to site and organizational or corporate management.	
<b>Reviewing Action Plan</b>	No reviews.	Informal check on progress.	Revise plan based on results, feedback and business factors. Best practices shared with other sites / organization or corporate program.	
<b>Recognize Achievements</b>				
<b>Site Recognition</b>	Not addressed.	Occasional recognition of projects and people.	Recognition system in place. Awards for projects pursued by operators.	
<b>Organizational Recognition</b>	Not sought.	Occasionally when prompted by senior management.	Senior management acknowledges site successes.	
<b>External Recognition</b>	Not sought.	Occasional trade magazine and vendor recognition.	Government and third-party recognition highlighting achievements sought. ENERGY STAR label for facility awarded annually.	

## **Appendix B: Basic Energy Efficiency Actions for Plant Personnel**

Personnel at all levels should be aware of energy use and organizational goals for energy efficiency. Staff should be trained in both skills and general approaches to energy efficiency in day-to-day practices. In addition, performance results should be regularly evaluated and communicated to all personnel, recognizing high achievement. Some examples of simple tasks employees can do are outlined below (Caffal 1995).

- Eliminate unnecessary energy consumption by equipment. Switch off motors, fans, and machines when they are not being used, especially at the end of the working day or shift, and during breaks, when it does not affect production, quality, or safety. Similarly, turn on equipment no earlier than needed to reach the correct settings (temperature, pressure) at the start time.
- Switch off unnecessary lights; rely on daylighting whenever possible.
- Use weekend and night setbacks on HVAC in offices or air conditioned buildings.
- Report leaks of water (both process water and dripping taps), steam, and compressed air. Ensure they are repaired quickly. The best time to check for leaks is a quiet time like the weekend.
- Look for unoccupied areas being heated or cooled, and switch off heating or cooling.
- Check that heating controls are not set too high or cooling controls set too low. In this situation, windows and doors are often left open to lower temperatures instead of lowering the heating.
- Check to make sure the pressure and temperature of equipment is not set too high.
- Prevent drafts from badly fitting seals, windows and doors, and hence, leakage of cool or warm air.
- Carry out regular maintenance of energy-consuming equipment.
- Ensure that the insulation on process heating equipment is effective.

### **Reference**

Caffal, C. (1995). Energy Management in Industry. Centre for the Analysis and Dissemination of Demonstrated Energy Technologies (CADDET), The Netherlands. Analysis Series 17, December.

## **Appendix C: Support Programs for Industrial Energy Efficiency Improvement**

This appendix provides a list of energy efficiency support available to industry. A brief description of the program or tool is given, as well as information on its target audience and the URL for the program. Included are federal and state programs. Use the URL to obtain more information from each of these sources. An attempt was made to provide as complete a list as possible; however, information in this listing may change with the passage of time.

### **Tools for Self-Assessment**

#### **Steam System Assessment Tool (SSAT)**

Description: Software package to evaluate energy efficiency improvement projects for steam systems. It includes an economic analysis capability.

Target Group: Any industry operating a steam system

Format: Downloadable software package (13.6 MB)

Contact: U.S. Department of Energy

URL: [http://www1.eere.energy.gov/manufacturing/tech\\_deployment/software\\_ssat.html](http://www1.eere.energy.gov/manufacturing/tech_deployment/software_ssat.html)

#### **Steam System Scoping Tool**

Description: Spreadsheet tool for plant managers to identify energy efficiency opportunities in industrial steam systems.

Target Group: Any industrial steam system operator

Format: Downloadable software (Excel)

Contact: U.S. Department of Energy

URL: [http://www1.eere.energy.gov/manufacturing/tech\\_deployment/software\\_ssat.html](http://www1.eere.energy.gov/manufacturing/tech_deployment/software_ssat.html)

#### **3E Plus<sup>®</sup>: Insulation Thickness Computer Program**

Description: Downloadable software to determine whether boiler systems can be optimized through the insulation of boiler steam lines. The program calculates the most economical thickness of industrial insulation for a variety of operating conditions. It makes calculations using thermal performance relationships of generic insulation materials included in the software.

Target Group: Energy and plant managers

Format: Downloadable software

Contact: U.S. Department of Energy

URL: [http://www1.eere.energy.gov/manufacturing/tech\\_deployment/software\\_ssat.html](http://www1.eere.energy.gov/manufacturing/tech_deployment/software_ssat.html)

#### **MotorMaster+**

Description: Energy efficient motor selection and management tool, including a catalog of over 20,000 AC motors. It contains motor inventory management tools, maintenance log tracking, efficiency analysis, savings evaluation, energy accounting, and environmental reporting capabilities.

Target Group: Any industry

Format: Downloadable software (can also be ordered on CD)

Contact: U.S. Department of Energy

URL: <http://www1.eere.energy.gov/industry/bestpractices/software.html>

### **ASDMaster: Adjustable Speed Drive Evaluation Methodology and Application**

Description: Software program helps to determine the economic feasibility of an adjustable speed drive application, predict how much electrical energy may be saved by using an ASD, and search a database of standard drives.

Target Group: Any industry

Format: Software package (not free)

Contact: Electric Power Research Institute (EPRI), (800) 832-7322

URL: <http://www.epri-peac.com/products/asdmaster/asdmaster.html>

### **The 1-2-3 Approach to Motor Management**

Description: A step-by-step motor management guide and spreadsheet tool that can help motor service centers, vendors, utilities, energy-efficiency organizations, and others convey the financial benefits of sound motor management.

Target Group: Any industry

Format: Downloadable Microsoft Excel spreadsheet

Contact: Consortium for Energy Efficiency (CEE), (617) 589-3949

URL: <http://www.motorsmatter.org/tools/123approach.html>

### **AirMaster+: Compressed Air System Assessment and Analysis Software**

Description: Modeling tool that maximizes the efficiency and performance of compressed air systems through improved operations and maintenance practices

Target Group: Any industry operating a compressed air system

Format: Downloadable software

Contact: U.S. Department of Energy

URL: [http://www1.eere.energy.gov/manufacturing/tech\\_deployment/software\\_airmaster.html](http://www1.eere.energy.gov/manufacturing/tech_deployment/software_airmaster.html)

### **Fan System Assessment Tool (FSAT)**

Description: The Fan System Assessment Tool (FSAT) helps to quantify the potential benefits of optimizing a fan system. FSAT calculates the amount of energy used by a fan system, determines system efficiency, and quantifies the savings potential of an upgraded system.

Target Group: Any user of fans

Format: Downloadable software

Contact: U.S. Department of Energy

URL: [http://www1.eere.energy.gov/manufacturing/tech\\_deployment/software\\_fsat.html](http://www1.eere.energy.gov/manufacturing/tech_deployment/software_fsat.html)

### **Combined Heat and Power Application tool (CHP)**

Description: The Combined Heat and Power Application Tool (CHP) helps industrial users evaluate the feasibility of CHP for heating systems such as fuel-fired furnaces, boilers, ovens, heaters, and heat exchangers.

Target Group: Any industrial heat and electricity user

Format: Downloadable software

Contact: U.S. Department of Energy

URL: [http://www1.eere.energy.gov/manufacturing/tech\\_deployment/software\\_chp.html](http://www1.eere.energy.gov/manufacturing/tech_deployment/software_chp.html)

### **Pumping System Assessment Tool (PSAT)**

Description: The tool helps industrial users assess the efficiency of pumping system operations. PSAT uses achievable pump performance data from Hydraulic Institute standards and motor performance data from the MotorMaster+ database to calculate potential energy and associated cost savings.

Target Group: Any industrial pump user

Format: Downloadable software

Contact: U.S. Department of Energy

URL: [http://www1.eere.energy.gov/manufacturing/tech\\_deployment/software\\_psat.html](http://www1.eere.energy.gov/manufacturing/tech_deployment/software_psat.html)

### **Plant Energy Profiler/Integrated Tool Suite**

Description: The Plant Energy Profiler, or ePEP (formerly called Quick PEP) , is an online software tool provided by the U.S. Department of Energy to help industrial plant managers in the United States identify how energy is being purchased and consumed at their plant and also identify potential energy and cost savings. ePEP is designed so that the user can complete a plant profile in about an hour. The ePEP online tutorial explains what plant information is needed to complete an ePEP case.

Target Group: Any industrial plant

Format: Online software tool

Contact: U.S. Department of Energy

URL: [http://www1.eere.energy.gov/manufacturing/tech\\_deployment/software\\_epep.html](http://www1.eere.energy.gov/manufacturing/tech_deployment/software_epep.html)

### **ENERGY STAR Portfolio Manager**

Description: Online software tool helps to assess the energy performance of buildings by providing a 1-100 ranking of a building's energy performance relative to the national building market. Measured energy consumption forms the basis of the ranking of performance.

Target Group: Any building user or owner

Format: Online software tool

Contact: U.S. Environmental Protection Agency

URL: [http://www.energystar.gov/index.cfm?c=evaluate\\_performance.bus\\_portfoliomanager](http://www.energystar.gov/index.cfm?c=evaluate_performance.bus_portfoliomanager)

## **Assessment and Technical Assistance**

### **Industrial Assessment Centers**

Description: Small- to medium-sized manufacturing facilities can obtain a free energy and waste assessment. The audit is performed by a team of engineering faculty and students from 30 participating universities in the U.S. and assesses the plant's performance and recommends ways to improve efficiency.

Target Group: Small- to medium-sized manufacturing facilities with gross annual sales below \$75 million and fewer than 500 employees at the plant site.

Format: A team of engineering faculty and students visits the plant and prepares a written report with energy efficiency, waste reduction and productivity recommendations.

Contact: U.S. Department of Energy

URL: <http://www1.eere.energy.gov/industry/bestpractices/iacs.html>

### **Save Energy Now Assessments**

Description: The U.S. DOE conducts plant energy assessments to help manufacturing facilities across the nation identify immediate opportunities to save energy and money, primarily by focusing on energy-intensive systems, including process heating, steam, pumps, fans, and compressed air.

Target Group: Large plants

Format: Online request

Contact: U.S. Department of Energy

URL: [http://www1.eere.energy.gov/manufacturing/tech\\_deployment/energy\\_assessment.html](http://www1.eere.energy.gov/manufacturing/tech_deployment/energy_assessment.html)

### **Manufacturing Extension Partnership (MEP)**

Description: MEP is a nationwide network of not-for-profit centers in over 400 locations providing small- and medium-sized manufacturers with technical assistance. A center provides expertise and services tailored to the plant, including a focus on clean production and energy-efficient technology.

Target Group: Small- and medium-sized plants

Format: Direct contact with local MEP Office

Contact: National Institute of Standards and Technology, (301) 975-5020

URL: <http://www.mep.nist.gov/>

### **Small Business Development Center (SBDC)**

Description: The U.S. Small Business Administration (SBA) administers the Small Business Development Center Program to provide management assistance to small businesses through 58 local centers. The SBDC Program provides counseling, training and technical assistance in the areas of financial, marketing, production, organization, engineering and technical problems and feasibility studies, if a small business cannot afford consultants.

Target Group: Small businesses

Format: Direct contact with local SBDC

Contact: Small Business Administration, (800) 8-ASK-SBA

URL: <http://www.sba.gov/sbdc/>

### **ENERGY STAR – Selection and Procurement of Energy Efficient Products for Business**

Description: ENERGY STAR identifies and labels energy efficient office equipment. Look for products that have earned the ENERGY STAR. They meet strict energy efficiency guidelines set by the EPA. Office equipment included such items as



computers, copiers, faxes, monitors, multifunction devices, printers, scanners, transformers and water coolers.

Target Group: Any user of labeled equipment.

Format: Website

Contact: U.S. Environmental Protection Agency

URL: [http://www.energystar.gov/index.cfm?c=bulk\\_purchasing.bus\\_purchasing](http://www.energystar.gov/index.cfm?c=bulk_purchasing.bus_purchasing)

## **Training**

### **ENERGY STAR**

Description: As part of ENERGY STAR's work to promote superior energy management systems, energy managers for the companies that participate in ENERGY STAR are offered the opportunity to network with other energy managers in the partnership. The networking meetings are held monthly and focus on a specific strategic energy management topic to train and strengthen energy managers in the development and implementation of corporate energy management programs.

Target Group: Corporate and plant energy managers

Format: Web-based teleconference

Contact: Climate Protection Partnerships Division, U.S. Environmental Protection Agency

URL: <http://www.energystar.gov/>

### **Best Practices Program**

Description: The U.S. DOE Best Practices Program provides training and training materials to support the efforts of the program in efficiency improvement of utilities (compressed air, steam) and motor systems (including pumps). Training is provided regularly in different regions. One-day or multi-day trainings are provided for specific elements of the above systems. The Best Practices program also provides training on other industrial energy equipment, often in coordination with conferences.

Target Group: Technical support staff, energy and plant managers

Format: Various training workshops (one day and multi-day workshops)

Contact: Office of Industrial Technologies, U.S. Department of Energy

URL: <http://www1.eere.energy.gov/industry/bestpractices/training.html>

### **Compressed Air Challenge®**

Description: The not-for-profit Compressed Air Challenge® develops and provides training on compressed air system energy efficiency via a network of sponsoring organizations in the United States and Canada. Three levels of training are available: (1) Fundamentals (1 day); (2) Advanced (2 days); and (3) Qualified Specialist (3-1/2 days plus an exam). Training is oriented to support implementation of an action plan at an industrial facility.

Target Group: Compressed air system managers, plant engineers

Format: Training workshops

Contact: Compressed Air Challenge: [Info@compressedairchallenge.org](mailto:Info@compressedairchallenge.org)

URL: <http://www.compressedairchallenge.org/>

## **Financial Assistance**

Below major federal programs are summarized that provide assistance for energy efficiency investments. Many states also offer funds or tax benefits to assist with energy efficiency projects (see below for State Programs). However, these programs can change over time, so it is recommended to review current policies when making any financial investment decisions.

### **Industries of the Future - U.S. Department of Energy**

Description: Collaborative R&D partnerships in nine vital industries. The partnership consists of the development of a technology roadmap for the specific sector and key technologies, and cost-shared funding of research and development projects in these sectors.

Target Group: Nine selected industries: agriculture, aluminum, chemicals, forest products, glass, metal casting, mining, petroleum and steel.

Format: Solicitations (by sector or technology)

Contact: U.S. Department of Energy – Office of Industrial Technologies

URL: <http://www.eere.energy.gov/industry/technologies/industries.html>

### **Small Business Administration (SBA)**

Description: The Small Business Administration provides several loan and loan guarantee programs for investments (including energy-efficient process technology) for small businesses.

Target Group: Small businesses

Format: Direct contact with SBA

Contact: Small Business Administration

URL: <http://www.sba.gov/>

## **State and Local Programs**

Many state and local governments have general industry and business development programs that can be used to assist businesses in assessing or financing energy-efficient process technology or buildings. Please contact your state and local government to determine what tax benefits, funding grants, or other assistance they may be able to provide your organization. This list should not be considered comprehensive but instead merely a short list of places to start in the search for project funding. These programs can change over time, so it is recommended to review current policies when making any financial investment decisions.

### **Database of State Incentives for Renewables & Efficiency (DSIRE)**

Description: DSIRE is a comprehensive source of information on state, local, utility, and federal incentives and policies that promote renewable energy and energy efficiency. Established in 1995, DSIRE is an ongoing project of the NC Solar Center and the Interstate Renewable Energy Council funded by the U.S. Department of Energy.

Target Group: Any industry

URL: <http://www.dsireusa.org/>

### **Summary of Motor and Drive Efficiency Programs by State**

Description: A report that provides an overview of state-level programs that support the use of NEMA Premium® motors, ASDs, motor management services, system optimization and other energy management strategies.

Target Group: Any industry

Contact: Consortium for Energy Efficiency (CEE), (617) 589-3949

URL: <http://www.cee1.org/ind/programsummary/index.php>

### **California – Public Interest Energy Research (PIER)**

Description: PIER provides funding for energy efficiency, environmental and renewable energy projects in the state of California. Although there is a focus on electricity, fossil fuel projects are also eligible.

Target Group: Targeted industries (e.g. food industries) located in California

Format: Solicitation

Contact: California Energy Commission, (916) 654-4392

URL: <http://www.energy.ca.gov/contracts/index.html>

### **California – Energy Innovations Small Grant Program (EISG)**

Description: The Energy Innovations Small Grant (EISG) Program provides up to \$95,000 for hardware projects and \$50,000 for modeling projects to small businesses, non-profits, individuals and academic institutions to conduct research that establishes the feasibility of new, innovative energy concepts. Research projects must target one of the PIER R&D areas, address a California energy problem and provide a potential benefit to California electric and natural gas ratepayers.

Target Group: All businesses in California

Format: Solicitation

Contact: California Energy Commission, (619) 594-1049

URL: <http://www.energy.ca.gov/research/innovations/>

### **California – Savings by Design**

**Description:** Design assistance is available to building owners and to their design teams for energy-efficient building design. Financial incentives are available to owners when the efficiency of the new building exceeds minimum thresholds, generally 10% better than California’s Title 24 standards. The maximum owner incentive is \$150,000 per free-standing building or individual meter. Design team incentives are offered when a building design saves at least 15%. The maximum design team incentive per project is \$50,000.

**Target Group:** Nonresidential new construction or major renovation projects

**Format:** Open year round

**URL:** <http://www.savingsbydesign.com/>

### **Indiana – Commercial and Industrial Loan Program**

**Description:** The Indiana Office of Energy Development (OED) Commercial and Industrial Loan Program provides low-interest loans to Indiana’s industrial and commercial sectors. This program provides funding of \$50,000-\$500,000 for projects designed to reduce energy consumption through energy efficient retrofits. Examples of appropriate technology include, but are not limited to, lighting, energy management systems, chillers, furnaces, boilers, insulation, windows, and compressed air systems. Prior to application, an energy audit must be performed; however, this is an expense that may be added to total project cost for financing.

**Target Group:** Commercial and industrial companies located in Indiana.

**Format:** Application during specific program window. Additional rounds as funding becomes available.

**Contact:** Indiana Office of Energy Development, (317) 232-8939

**URL:** [www.energy.in.gov](http://www.energy.in.gov)

### **Iowa – Alternate Energy Revolving Loan Program**

**Description:** The Alternate Energy Revolving Loan Program (AERLP) was created to promote the development of renewable energy production facilities in the state.

**Target Group:** Any potential user of renewable energy

**Format:** Proposals under \$50,000 are accepted year-round. Larger proposals are accepted on a quarterly basis.

**Contact:** Iowa Energy Center, (515) 294-3832

**URL:** <http://www.energy.iastate.edu/Funding/index.htm>

### **New York – Industry Research and Development Programs**

**Description:** The New York State Energy Research & Development Agency (NYSERDA) operates various financial assistance programs for New York businesses. Different programs focus on specific topics, including process technology, combined heat and power, peak load reduction and control systems.

**Target Group:** Industries located in New York

**Format:** Solicitation

**Contact:** NYSERDA, (866) NYSERDA

**URL:** <http://www.nysERDA.ny.gov/en/Funding-Opportunities.aspx>

### **Oregon – Energy Trust Production Efficiency Program**

**Description:** Incentives for energy efficiency projects are offered for Oregon businesses that are serviced by either Pacific Power or Portland General Electric.

Current incentive levels are \$0.25/kWh saved up to 60% of the project cost. Lighting incentives are treated differently. There are standard incentive levels for specific fixture replacements (exp. \$30/fixture). If a fixture replacement does not qualify for a standard incentive, but it does save energy, a custom incentive can be calculated using \$0.17/kWh saved up to 35% of the project cost. Premium efficiency motor rebates are also offered at \$10/hp from 1 to 200 hp motors. Over 200 hp, the current incentive levels of \$0.25/kWh saved up to 60% of the project cost are used to calculate an incentive.

Target Group: Commercial and industrial companies in Oregon  
Contact: Energy Trust of Oregon, (509) 529-8040  
URL: [www.energytrust.org](http://www.energytrust.org)

**Wisconsin – Focus on Energy**

Description: Energy advisors offer free services to identify and evaluate energy-saving opportunities, recommend energy efficiency actions, develop an energy management plan for business; and integrate elements from national and state programs. It can also provide training.

Target Group: Industries in Wisconsin  
Format: Open year round  
Contact: Wisconsin Department of Administration, (800) 762-7077  
URL: <http://www.focusonenergy.com/>

## Appendix D: Teaming Up to Save Energy Checklist

The following checklist can be used as a handy reference to key tasks for establishing and sustaining an effective energy team. For more detailed information on energy teams, consult the U.S. EPA's *Teaming Up to Save Energy* guide, which is available at [www.energystar.gov](http://www.energystar.gov).

ORGANIZE YOUR ENERGY TEAM		√
Energy Director	Able to work with all staff levels from maintenance to engineers to financial officers. Senior-level person empowered by top management support	
Senior Management	Energy director reports to senior executive or to a senior management council. Senior champion or council provides guidance and support	
Energy Team	Members from business units, operations/engineering, facilities, and regions. Energy networks formed. Support services (PR, IT, HR).	
Facility Involvement	Facility managers, electrical personnel. Two-way information flow on goals and opportunities. Facility-based energy teams with technical person as site champion.	
Partner Involvement	Consultants, vendors, customers, and joint venture partners. Energy savings passed on through lower prices.	
Energy Team Structure	Separate division and/or centralized leadership. Integrated into organization's structure and networks established.	
Resources & Responsibilities	Energy projects incorporated into normal budget cycle as line item. Energy director is empowered to make decisions on projects affecting energy use. Energy team members have dedicated time for the energy program.	
STARTING YOUR ENERGY TEAM		√
Management Briefing	Senior management briefed on benefits, proposed approach, and potential energy team members.	
Planning	Energy team met initially to prepare for official launch.	
Strategy	Energy team met initially to prepare for official launch.	
Program Launch	Organizational kickoff announced energy network, introduced energy director, unveiled energy policy, and showcased real-world proof.	
Energy Team Plans	Work plans, responsibilities, and annual action plan established.	
Facility Engagement	Facility audits and reports conducted. Energy efficiency opportunities identified.	

<b>BUILDING CAPACITY</b>		√
Tracking and Monitoring	Systems established for tracking energy performance and best practices implementation.	
Transferring Knowledge	Events for informal knowledge transfer, such as energy summits and energy fairs, implemented.	
Raising Awareness	Awareness of energy efficiency created through posters, intranet, surveys, and competitions.	
Formal Training	Participants identified, needs determined, training held. Involvement in ENERGY STAR Web conferences and meetings encouraged. Professional development objectives for key team members.	
Outsourcing	Use of outside help has been evaluated and policies established.	
Cross-Company Networking	Outside company successes sought and internal successes shared. Information exchanged to learn from experiences of others.	
<b>SUSTAINING THE TEAM</b>		√
Effective Communications	Awareness of energy efficiency created throughout company. Energy performance information is published in company reports and communications.	
Recognition and Rewards	Internal awards created and implemented. Senior management is involved in providing recognition.	
External Recognition	Credibility for your organization's energy program achieved. Awards from other organizations have added to your company's competitive advantage.	
<b>MAINTAINING MOMENTUM</b>		√
Succession	Built-in plan for continuity established. Energy efficiency integrated into organizational culture.	
Measures of Success	Sustainability of program and personnel achieved. Continuous improvement of your organization's energy performance attained.	