

SLUG-INDUCED ELEVATION OF D1 CYCLIN IN BREAST CANCER CELLS THROUGH THE INHIBITION OF ITS UBIQUITINATION

Mukul K Mittal, Smita Misra and Gautam Chaudhuri
 Meharry Medical College, Nashville, TN, 37208

ABSTRACT

UbcH5c, a member of the UbcH5 family of protein ubiquitin conjugase E2 enzymes, is a critical component of biological processes in human cells being the initial ubiquitinating enzyme of substrates like Ikb, TP53 and cyclin D1. We report here that the metastasis regulator protein SLUG inhibits the expression of *UbcH5c* directly through chromatin remodeling and thus, among other downstream effects, elevates the level of cyclin D1, thus enhancing the growth rates of breast cancer cells. Overexpression of SLUG in the SLUG-deficient breast cancer cells significantly decreased the levels of mRNA and protein of UbcH5c but only elevated the protein levels of cyclin D1. On the contrary, knockdown of *SLUG* in SLUG-high breast cancer cells elevated the levels of UbcH5c while decreasing the level of cyclin D1 protein. SLUG is recruited at the E2-box sequence at the *UbcH5c* gene promoter along with the corepressor CtBP1 and the effector HDAC1 to silence the expression of this gene. Knockdown of *UbcH5c* in the SLUG-deficient human breast cells elevated the level of cyclin D1 as well as the rates of proliferation and invasiveness of these cells. While the growth rates of the cells are enhanced due to overexpression of SLUG or knockdown of UbcH5c in the breast cancer cells tested, ER+ cells also acquire resistance to the anti-estrogen 4-hydroxytamoxifen due to the rise of cyclin D1 levels in these cells. This study thus implicates high levels of SLUG and low levels of UbcH5c as a determinant in the progression of metastatic breast cancer.

BACKGROUND

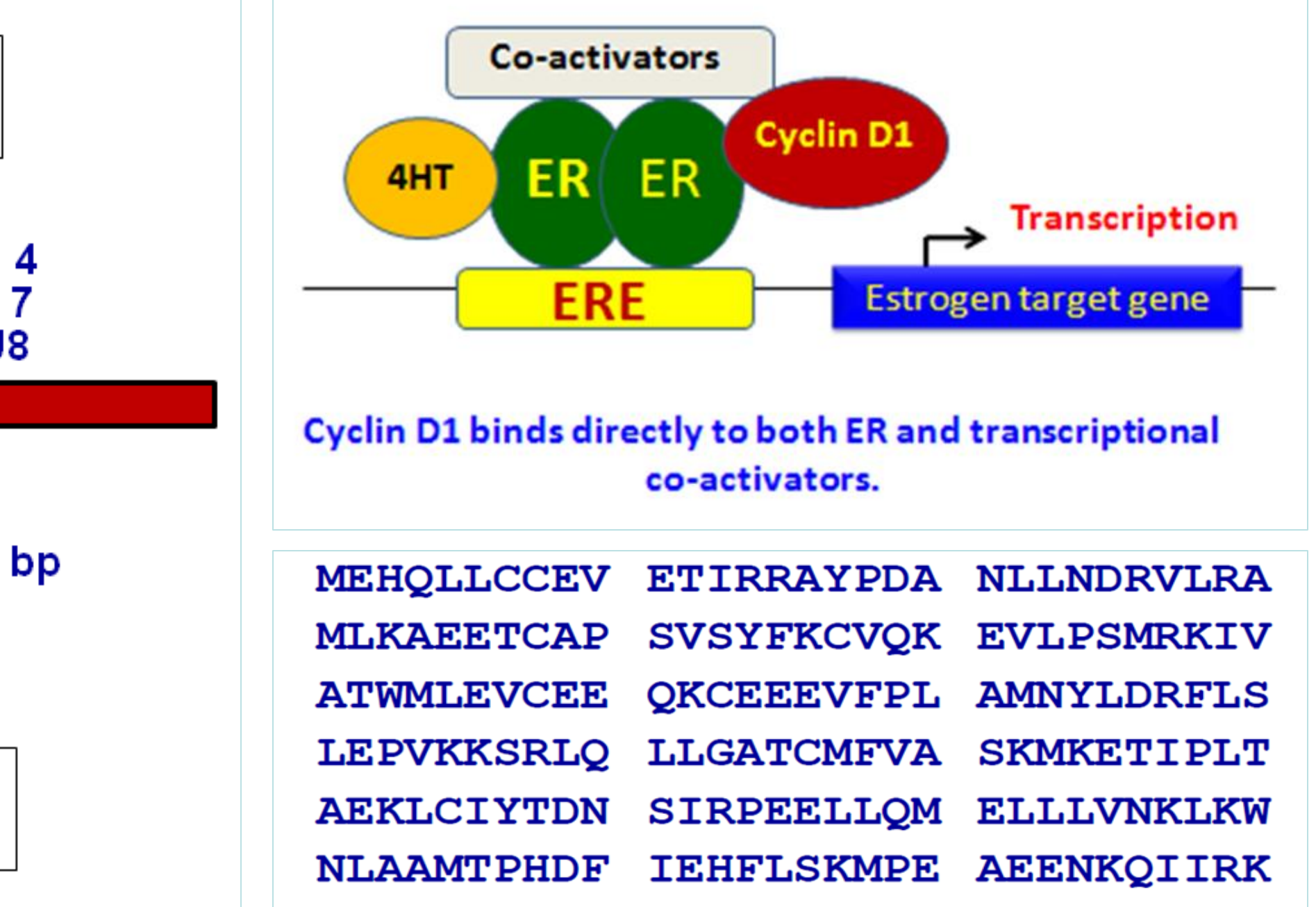
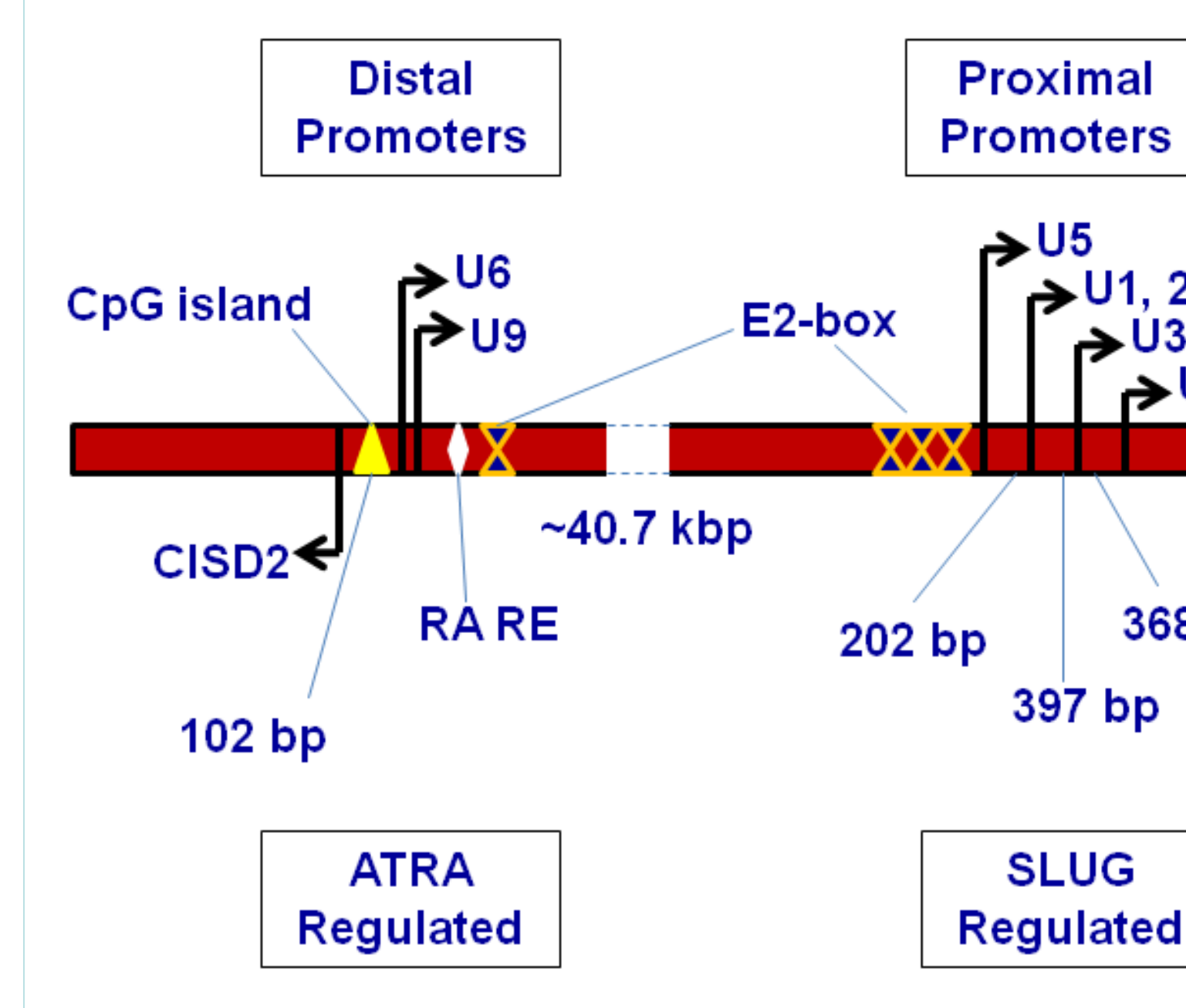
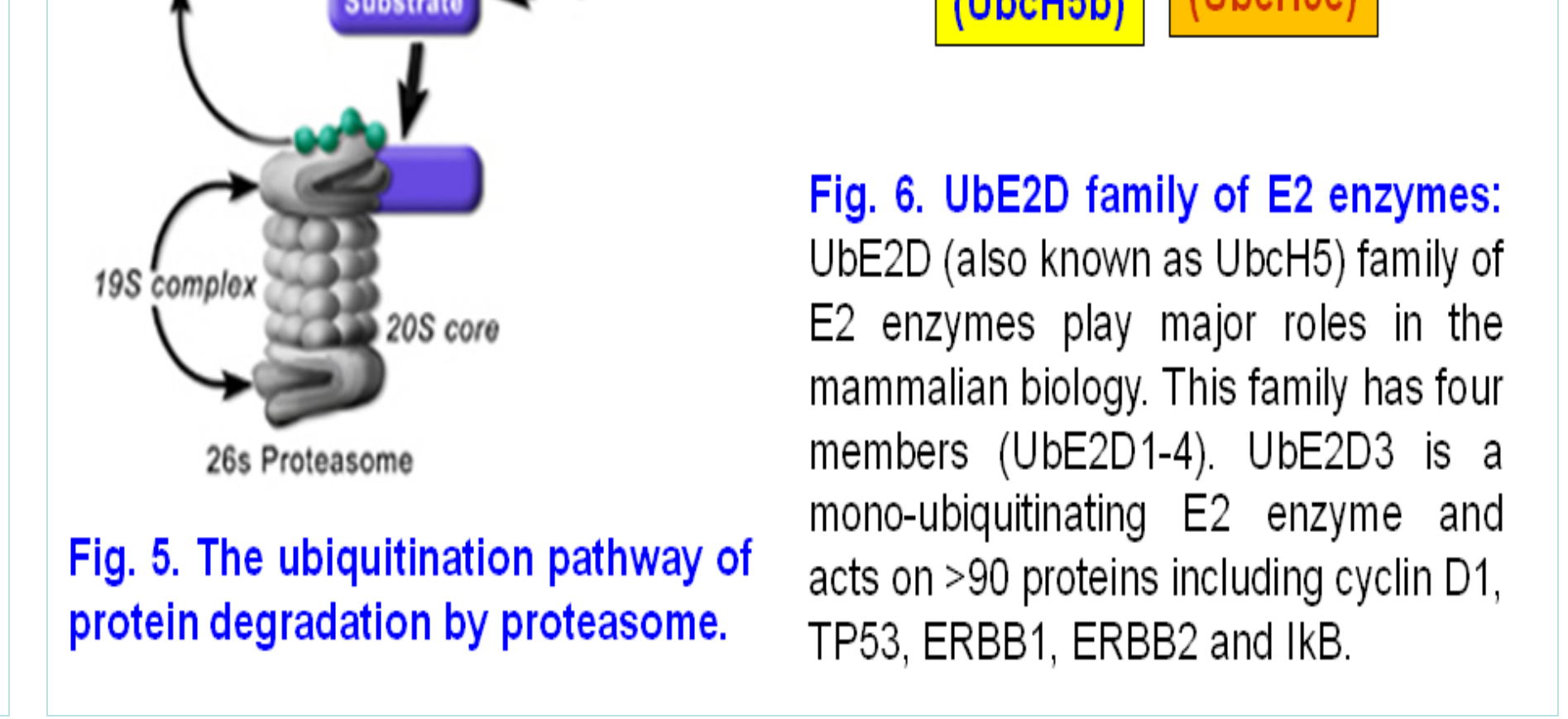
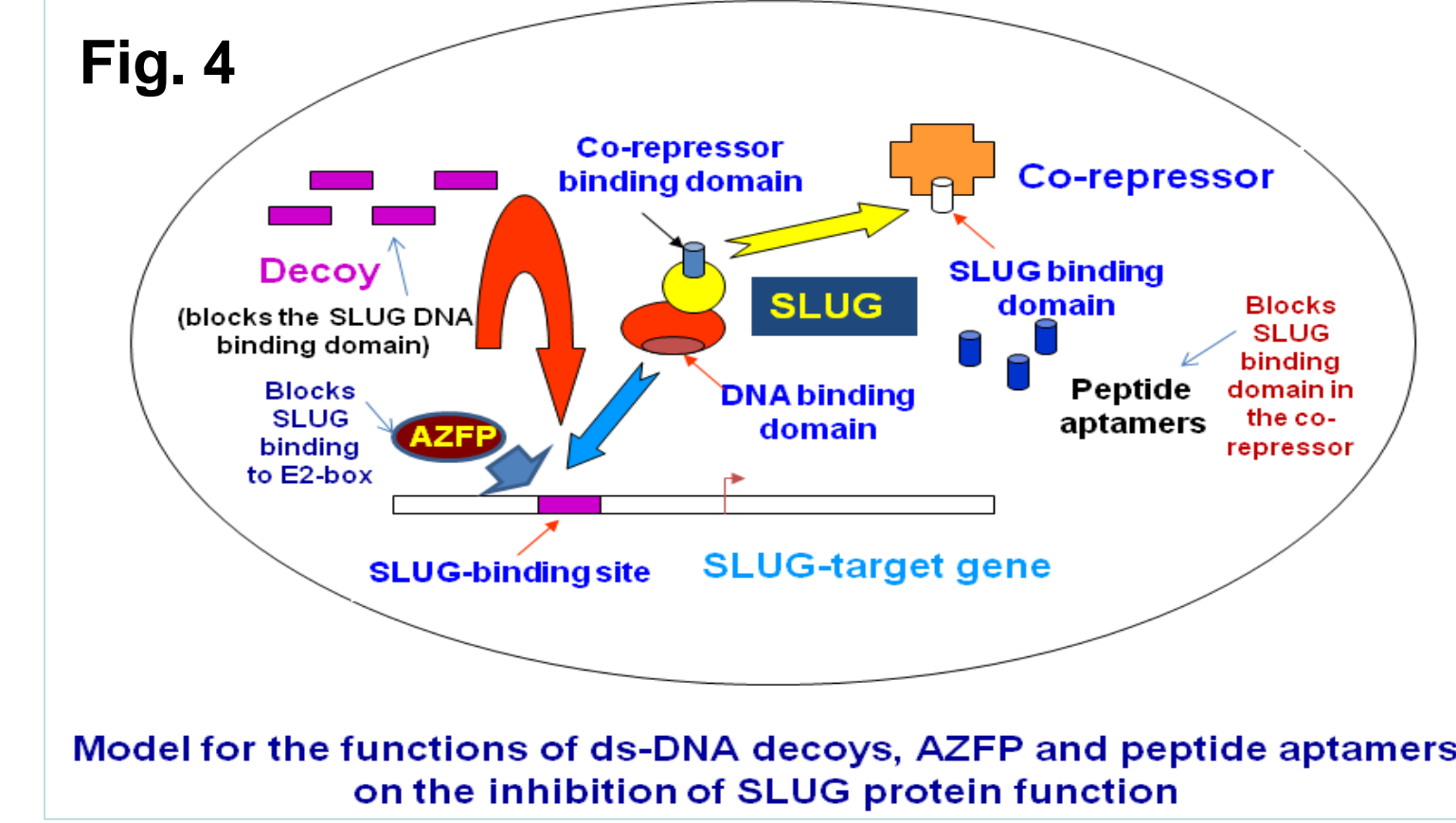
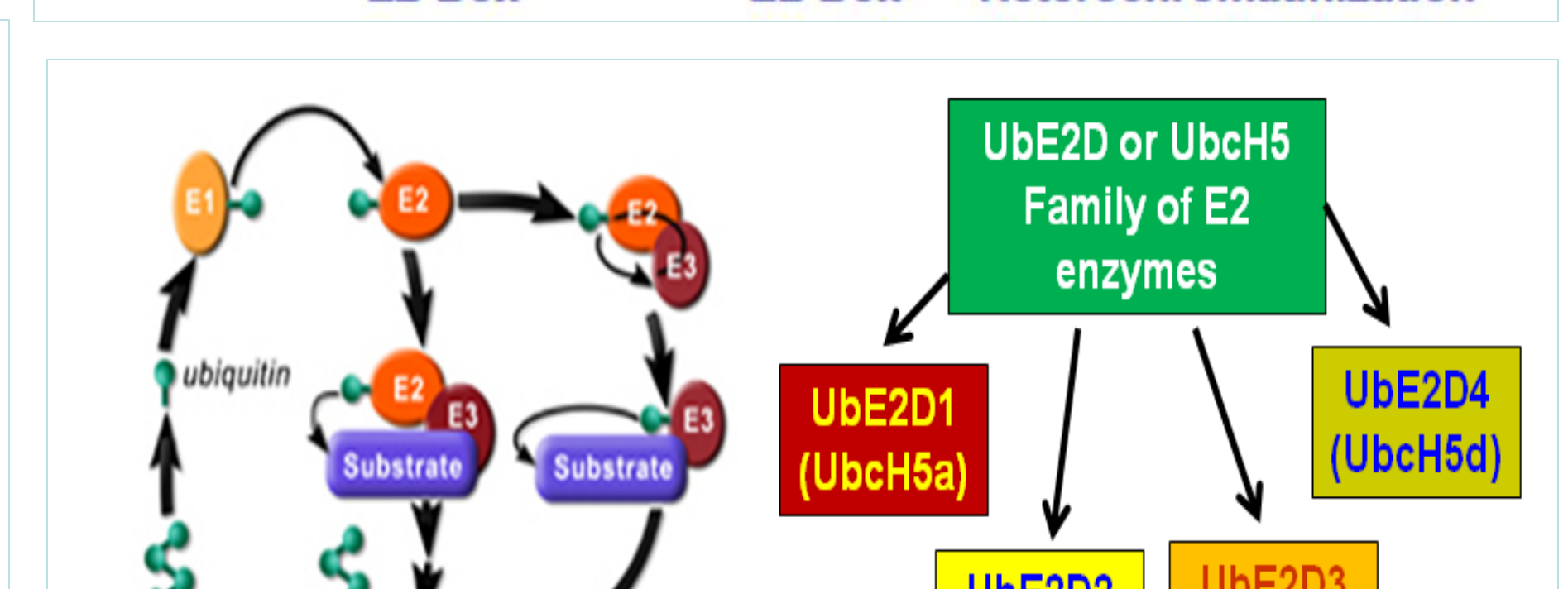
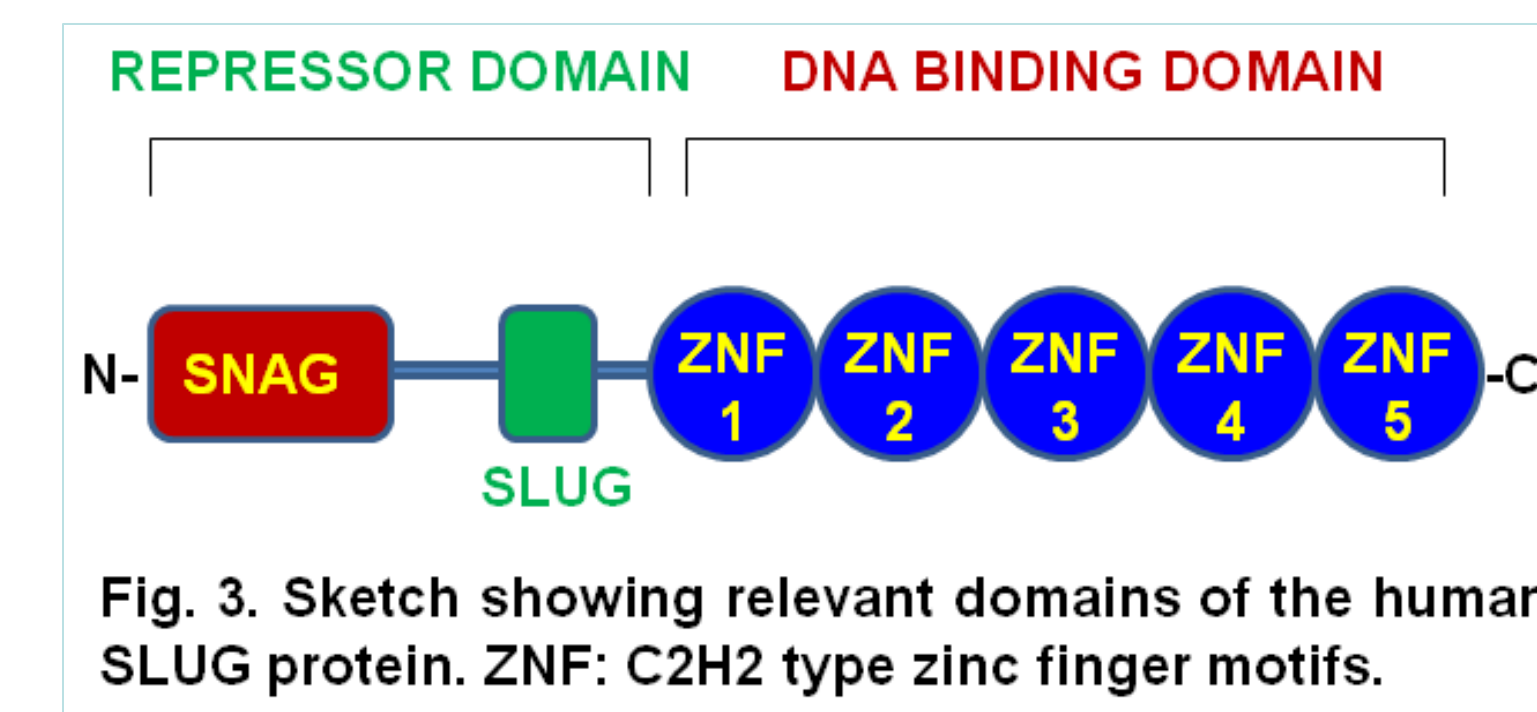
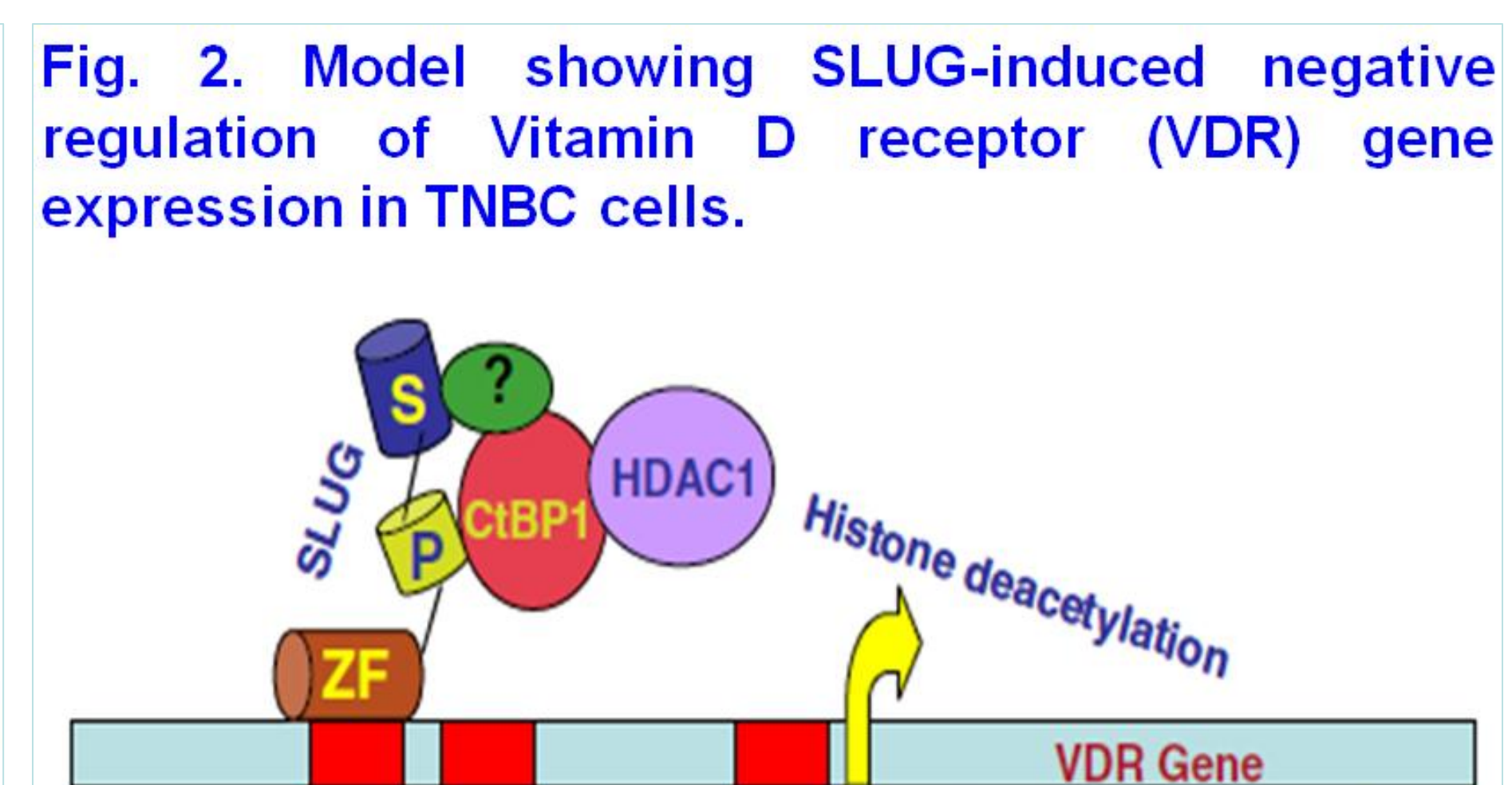
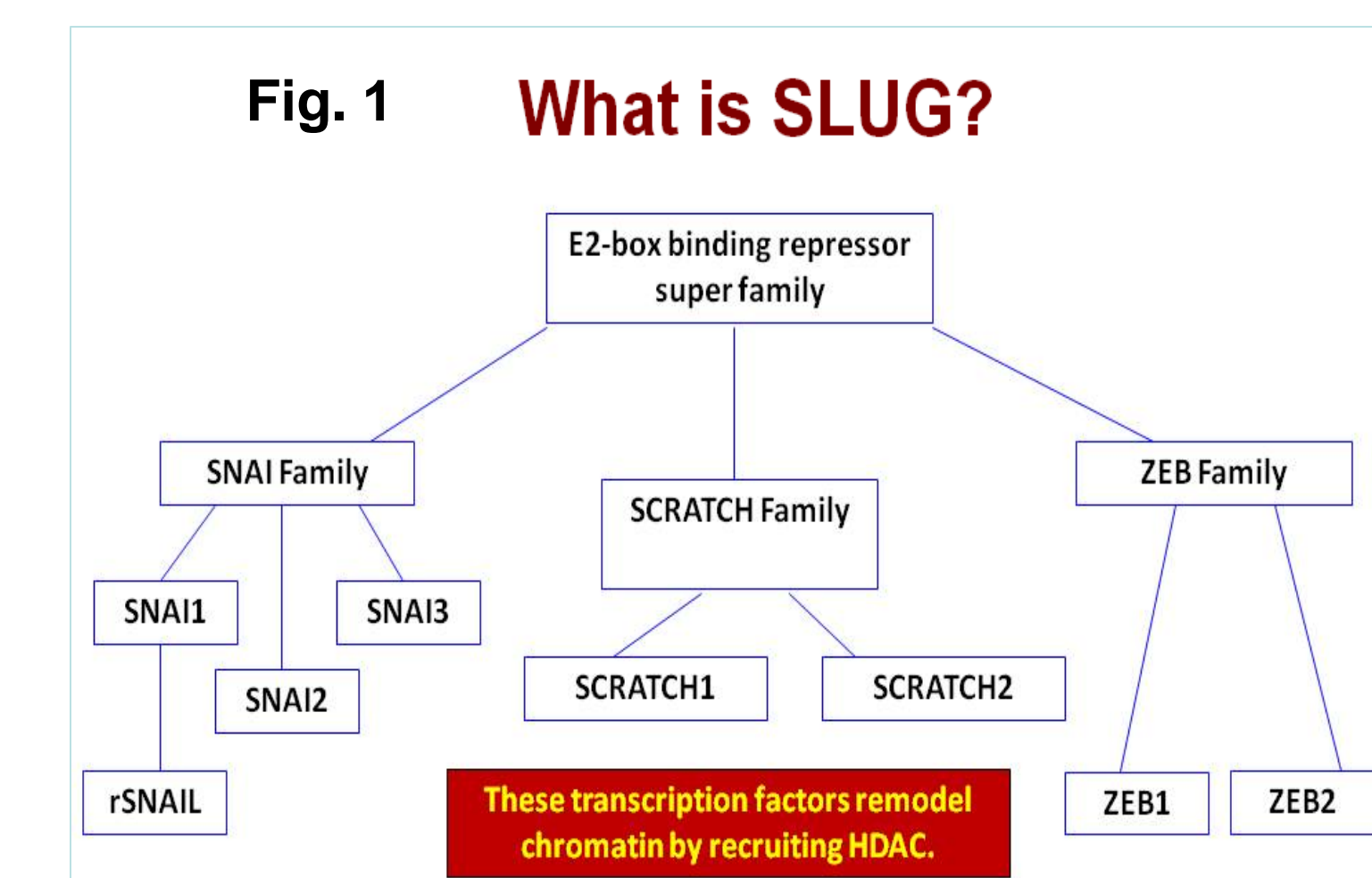

Fig. 7. Summary of the human Ube2D3 (UbcH5c) gene structure showing the approximate locations of transcription start sites (Us). The distal promoters are in bidirectional mode with the CISD2 gene. Locations of the potential SLUG binding E2-boxes are shown. The E2-box near the distal promoter does not bind to SLUG.

HYPOTHESIS

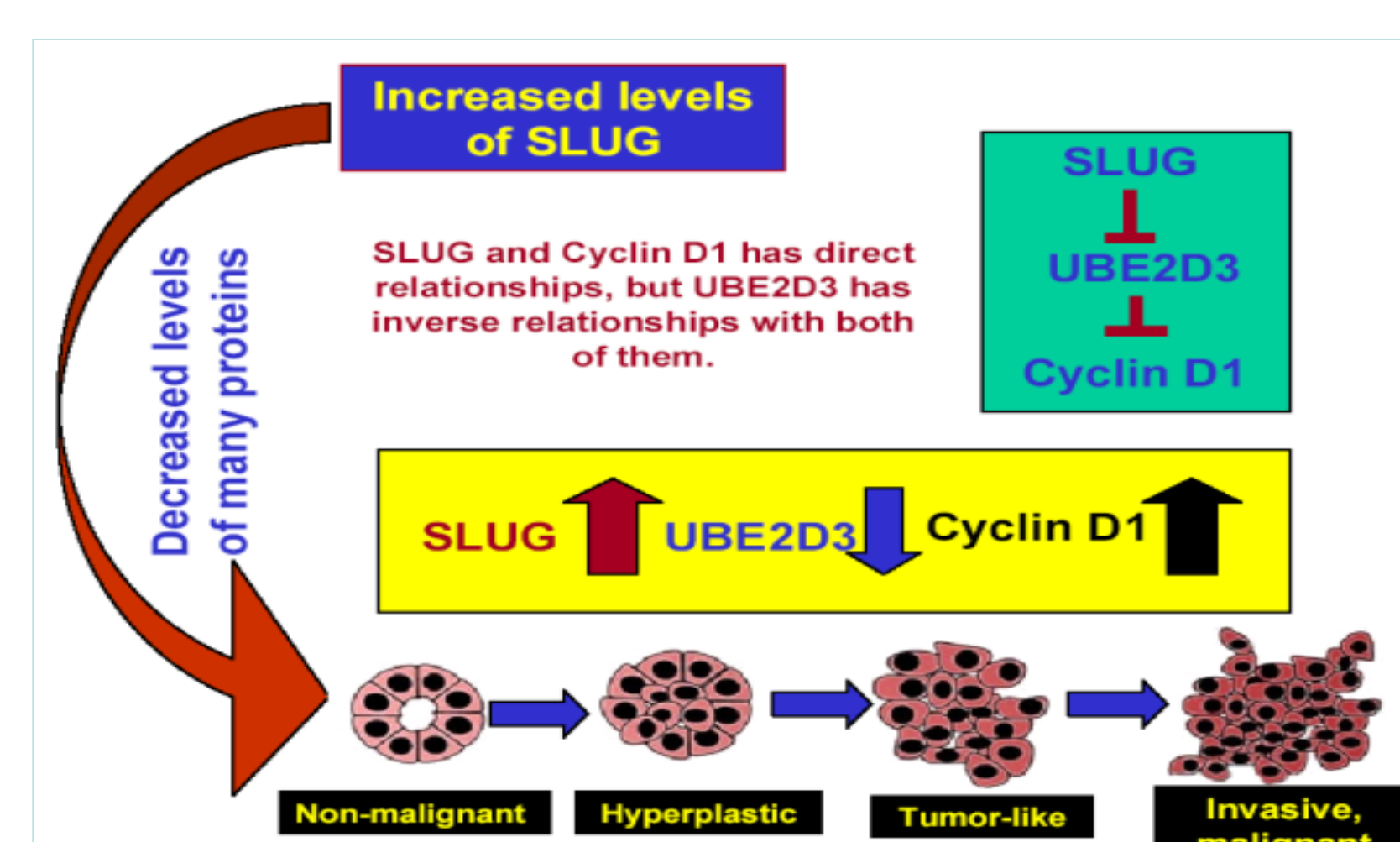

Fig. 9. Summary of our working hypothesis. We hypothesize that the transcriptional repressor protein SLUG down regulates many genes including the cyclin D1 regulator E2 enzyme UBE2D3. Decrease in the levels of UBE2D3 will increase the levels of cyclin D1 in the cells which will promote cell proliferation and perhaps oncogenesis.

RESULTS

1. Level of cyclin D1 in breast cancer cells is directly correlated with that of SLUG (Figs. 10 and 11).
2. Ectopic expression of SLUG in these SLUG-negative cells (MCF7 and MDA-MB-468) significantly decreased the levels of *UbcH5c* (Fig. 12) and increased their growth rate and resistance to 4-hydroxy tamoxifen (4HT) (Fig. 13).
3. Knockdown of SLUG in SLUG-high MDA-MB-231 and BT549 cells increased the level of UbcH5c, decreased the level of cyclin D1 (Fig. 14) and decreased the growth rate (Fig. 15) of these cells.
4. SLUG knockdown increased the proteasomal degradation of cyclin D1 in MDA-MB-231 cells (Fig. 16).
5. Knockdown of UbcH5c in SLUG-deficient breast cancer cells elevated cyclin D1 levels as well as their growth rates, invasiveness and resistance to 4HT (Figs. 17-19).
6. Ectopic expression of UbcH5c in SLUG-high MDA-MB-231 cells lowered cyclin D1 levels as well as decreased their growth rates (Fig. 20).
7. SLUG binds directly to the promoter of human *UbcH5c* gene in the nucleus of human breast cancer cells (Fig. 21).
8. SLUG inhibits the activity of cloned *UbcH5c* promoter in the transfected human breast cancer cells (Fig. 22).

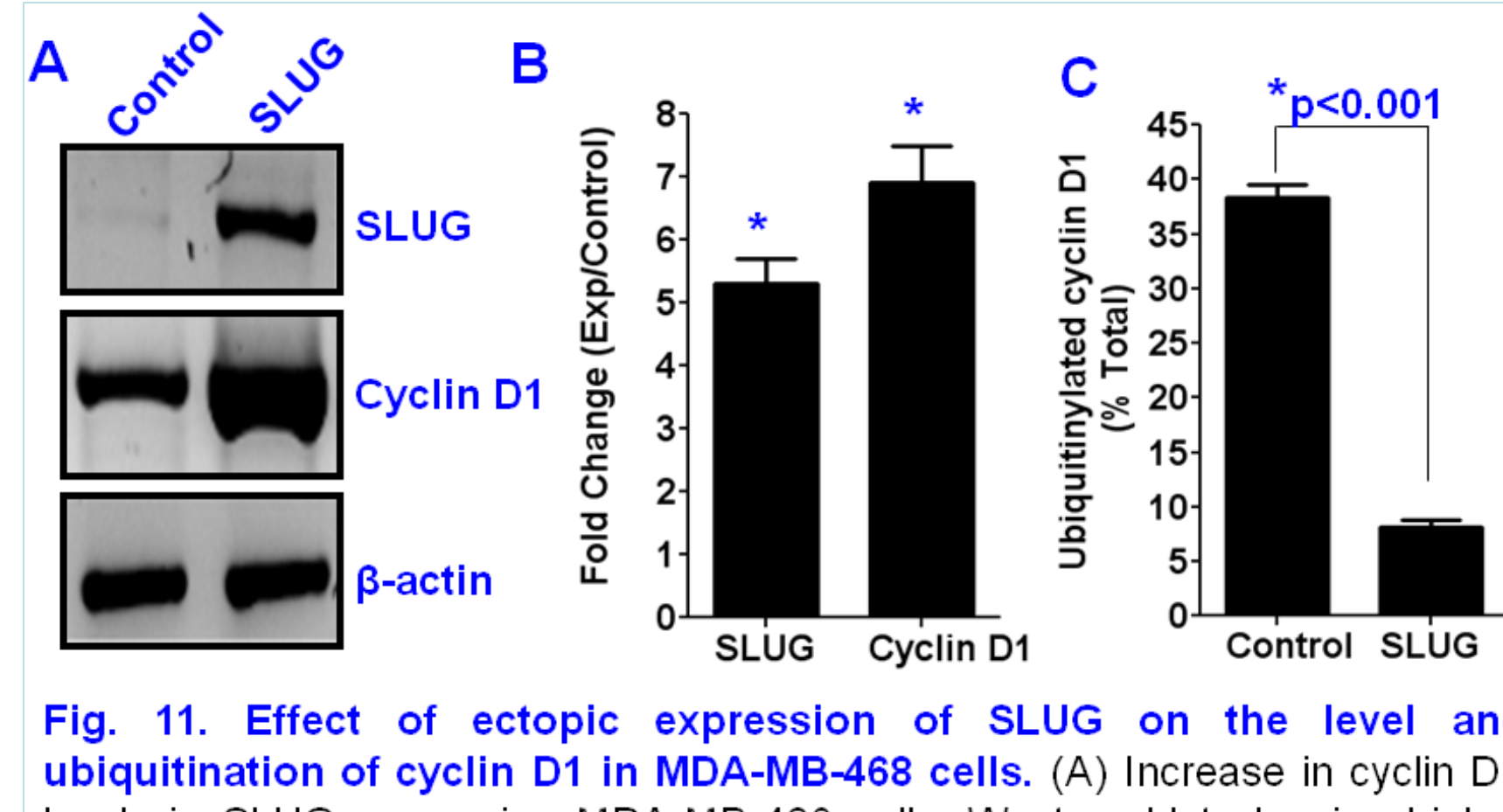
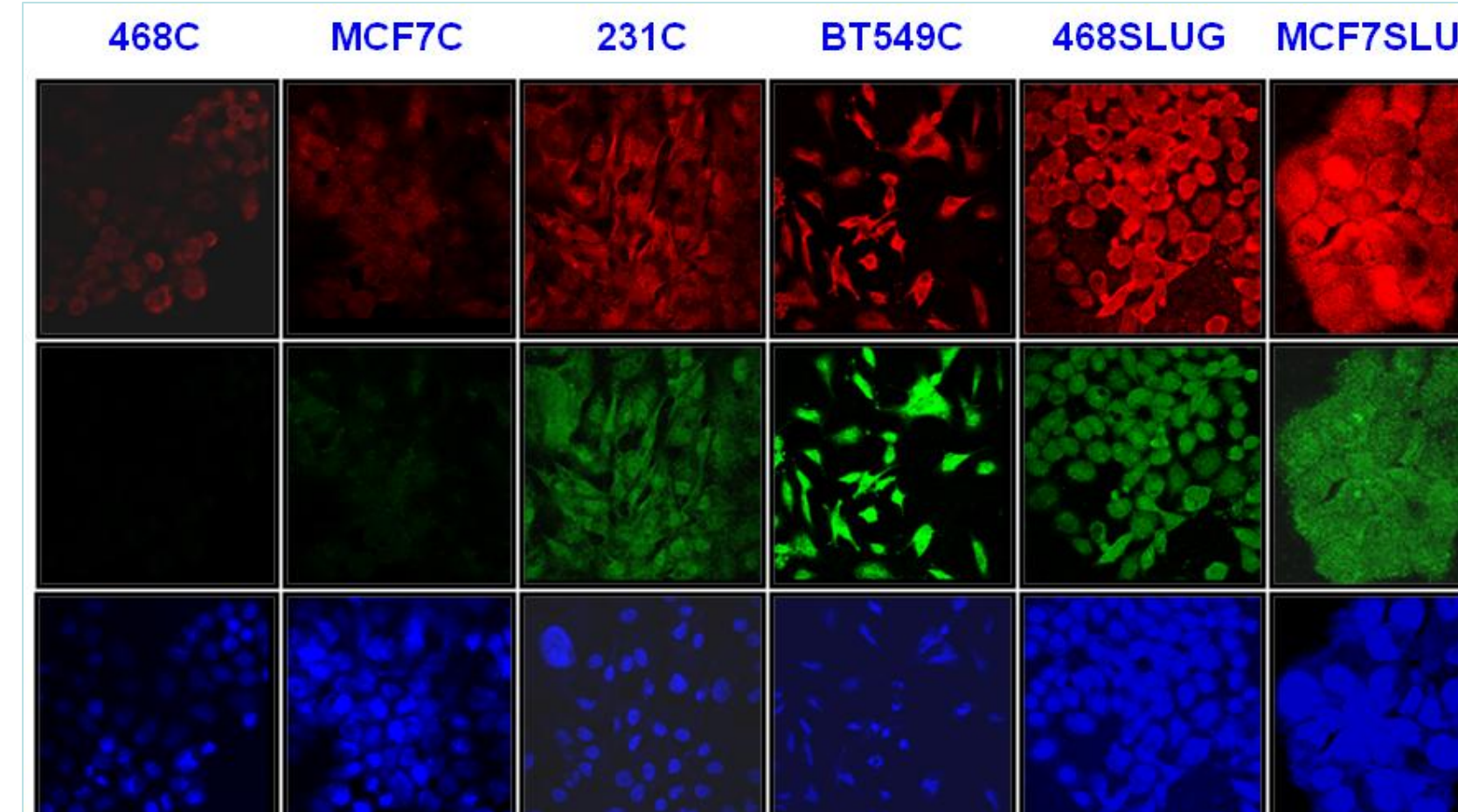

Fig. 10. Evaluation of the levels of cyclin D1 in normal and in SLUG-expressing human breast cancer cells by immunofluorescence microscopy. 468C and MCF7C: MDA-MB-468 and MCF7 cells transfected with empty vector; 468SLUG and MCF7SLUG: Cells expressing C-terminal FLAG-tagged SLUG; 231C and BT549C: Normal MDA-MB-231 and BT549 cells. Results are mean \pm SEM (n=6).

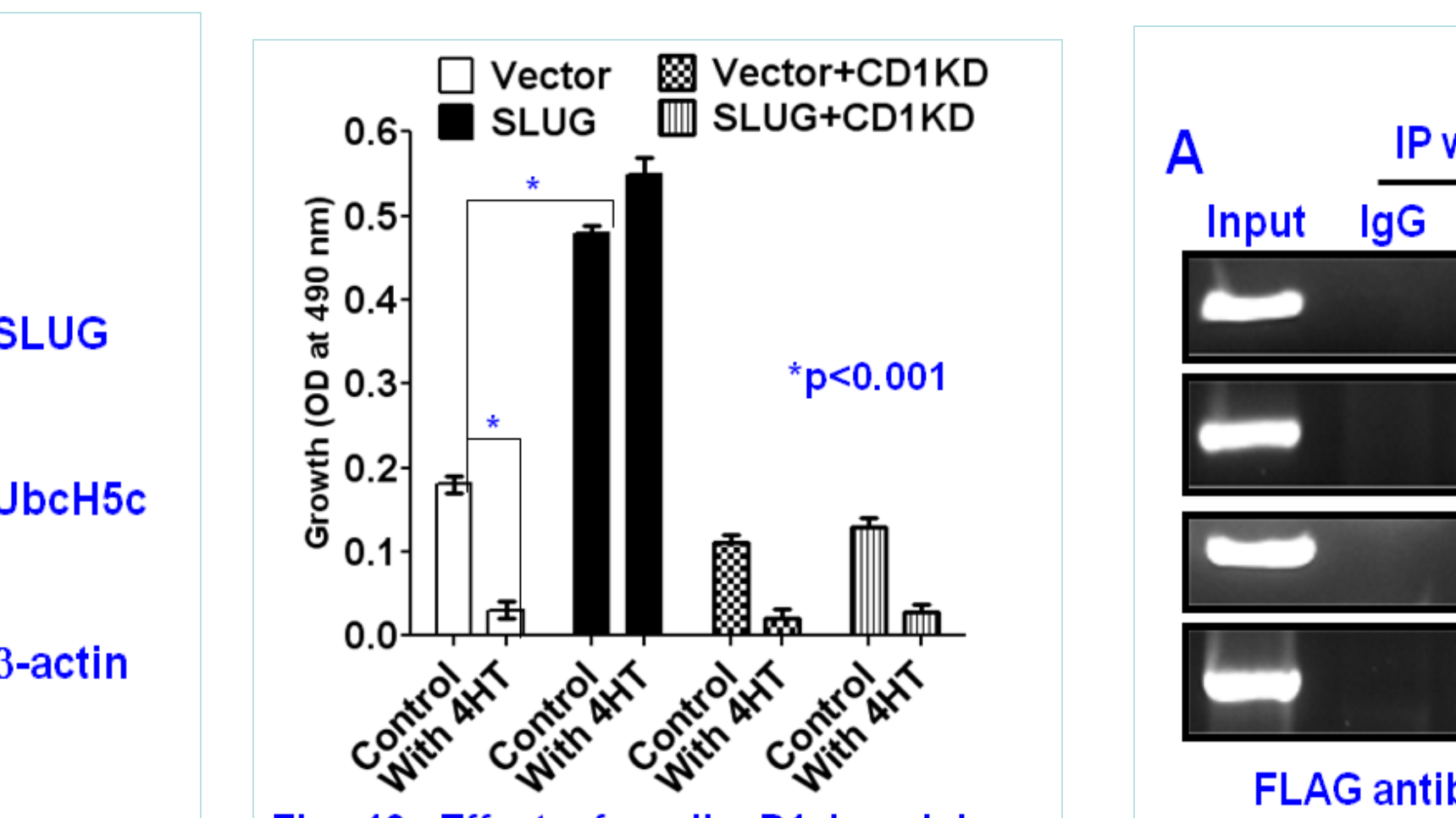
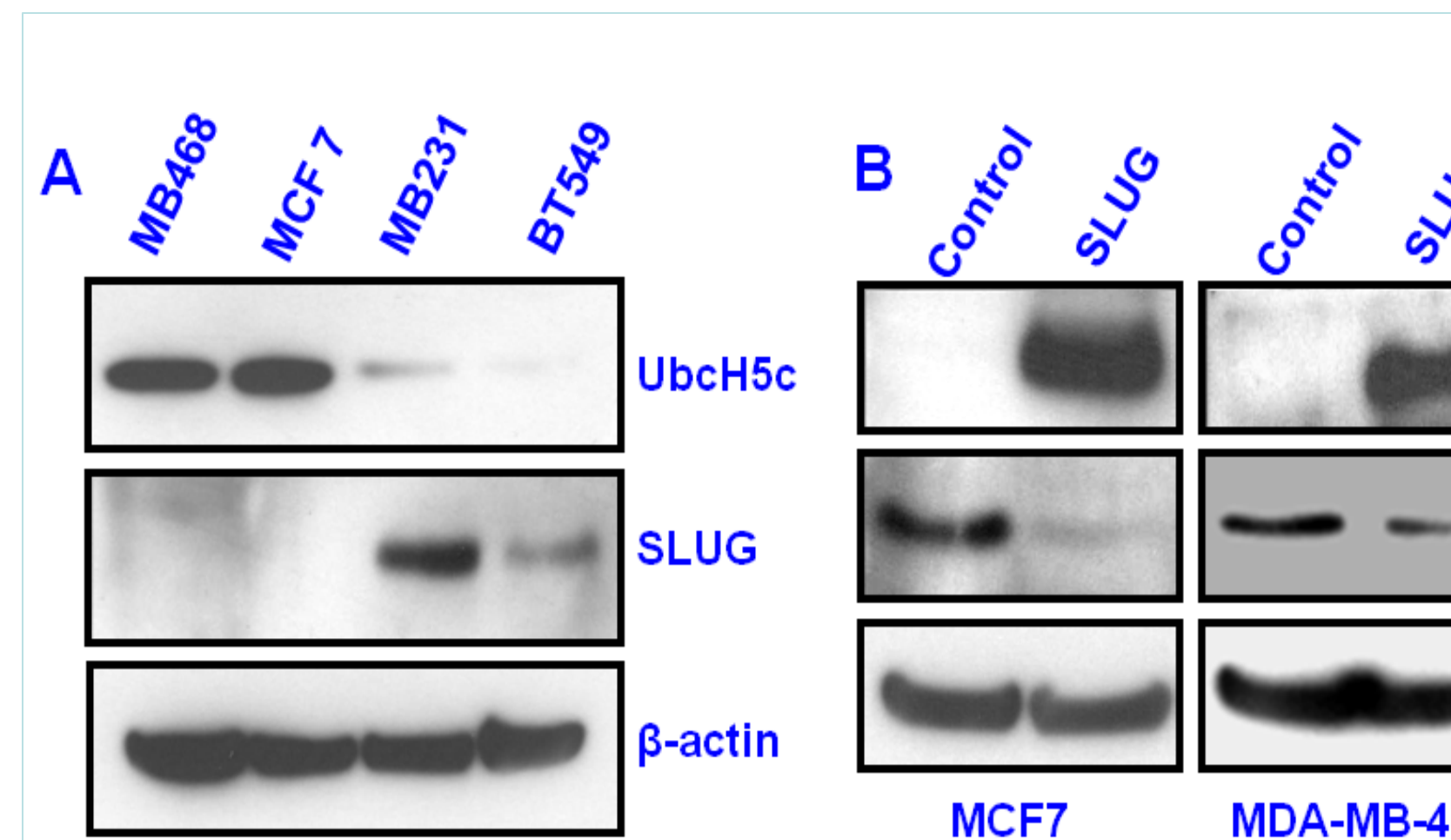

Fig. 12. Effect of SLUG expression on UbcH5c levels in different breast cancer cells. (A) A typical immunoblot showing UbcH5c and SLUG protein levels in different human breast cancer cells. (B) Immunoblot analysis for SLUG and UbcH5c proteins in the control and SLUG-over expressing (SLUG) MCF7 and MDA-MB-468 cells.

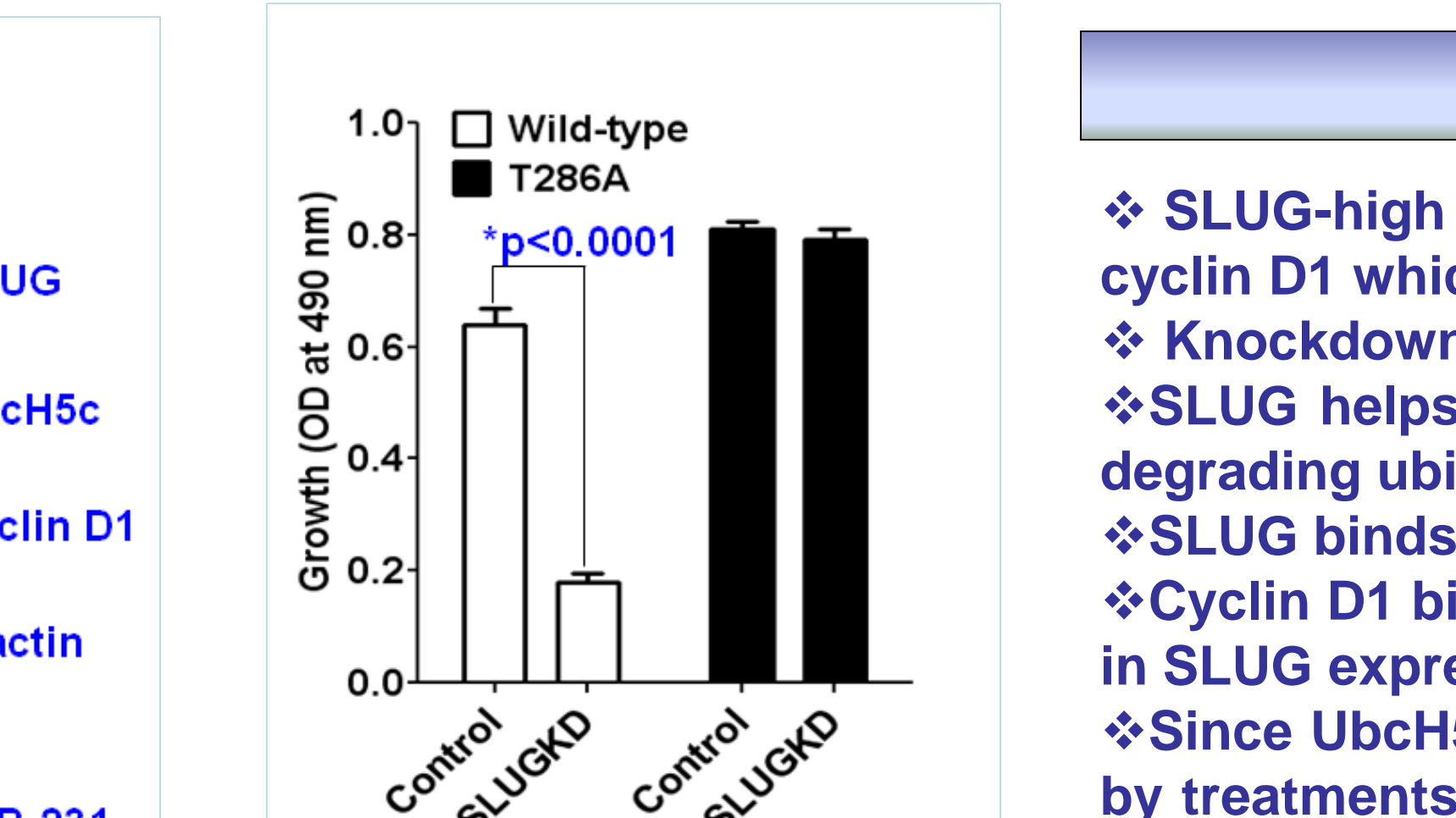
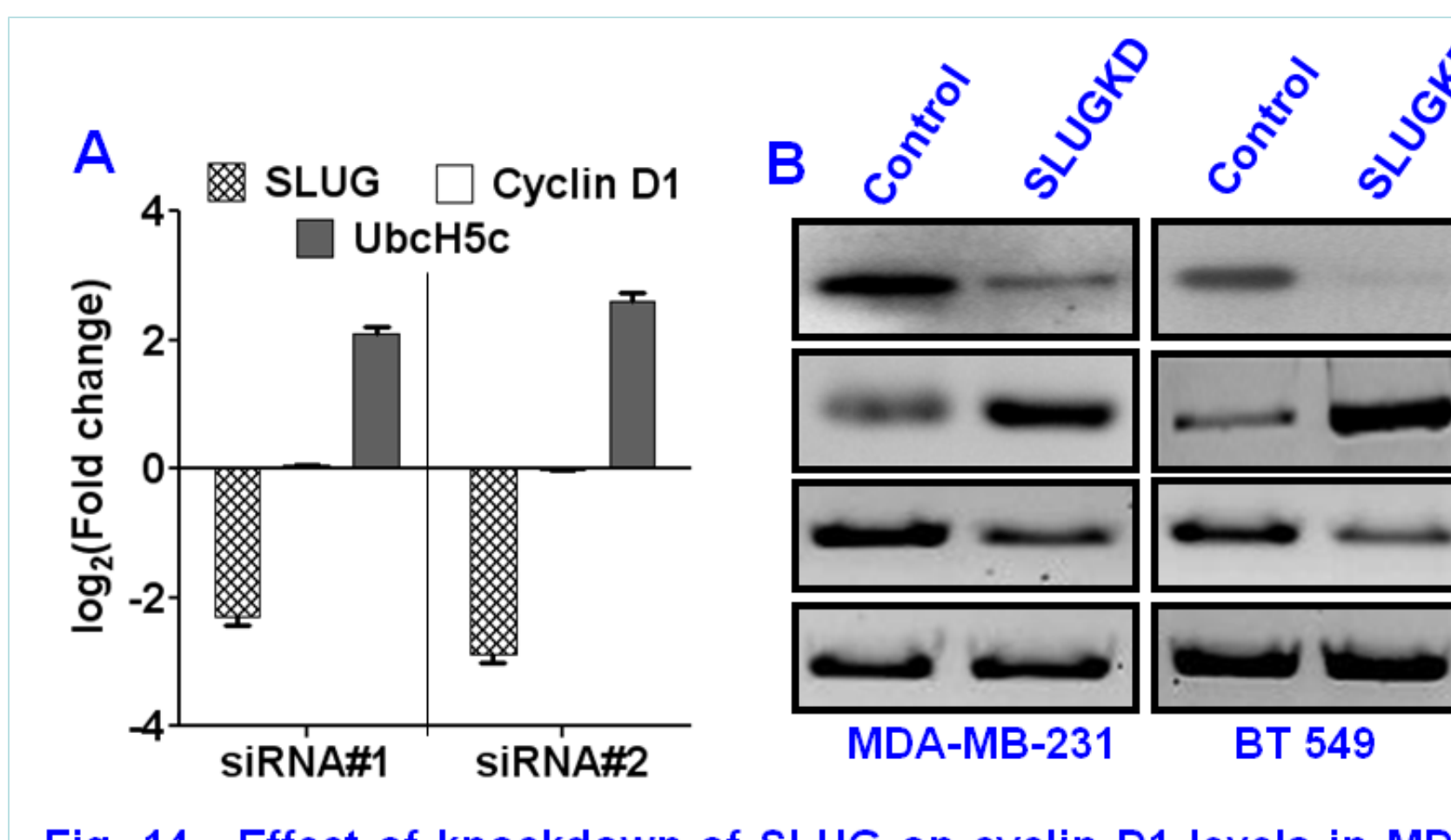

Fig. 14. Effect of knockdown of SLUG on cyclin D1 levels in MDA-MB-231 and BT549 cells. (A) Quantitative RT-PCR analysis for *SLUG*, *UbcH5c* and *cyclin D1* mRNA levels in MDA-MB-231 cells treated with different siRNAs. (B) Immunoblot analysis of UbcH5c and cyclin D1 levels in MDA-MB-231 and BT549 cells by with (SLUGKD) or without (Control) knocking down SLUG (siRNA#1, stealth-21). Control cells were transfected with control siRNA.

RESULTS

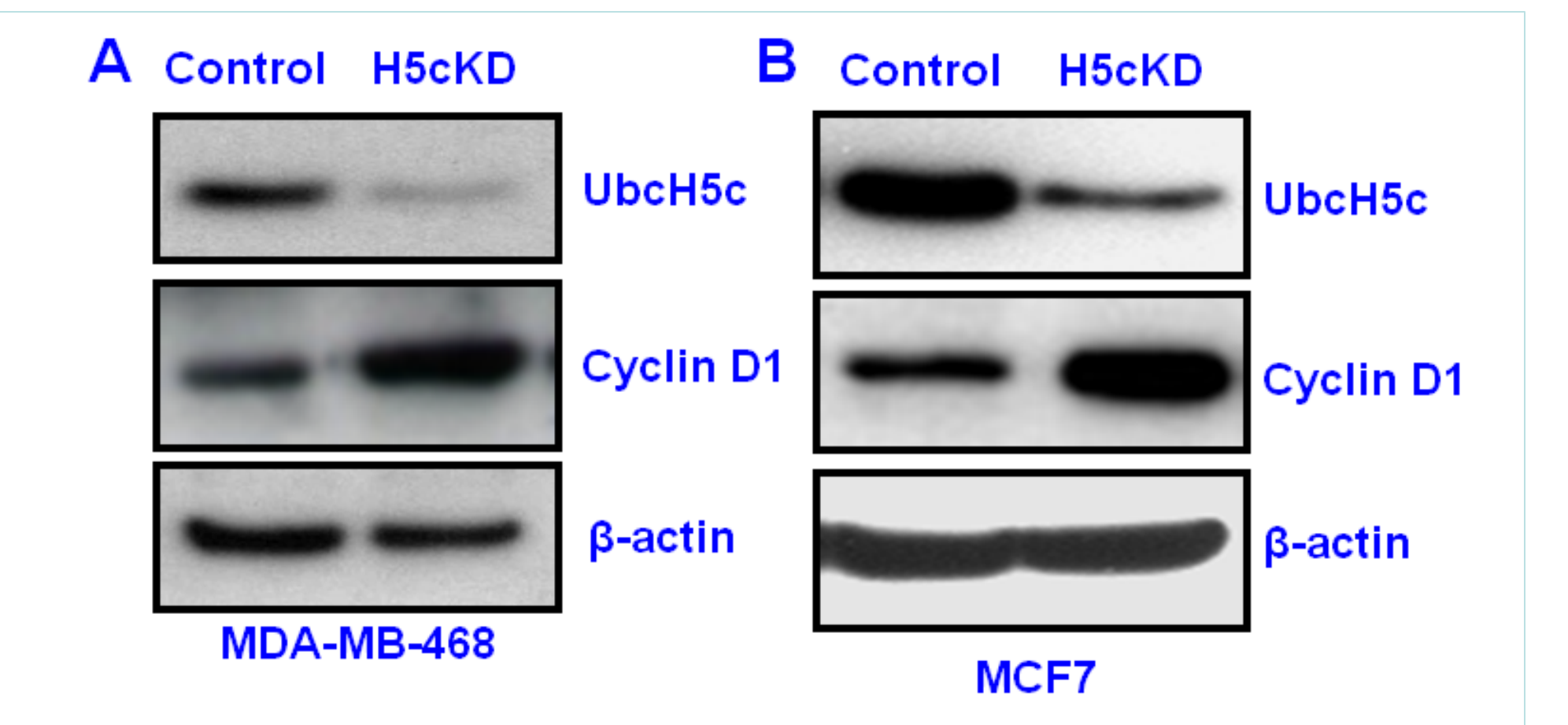
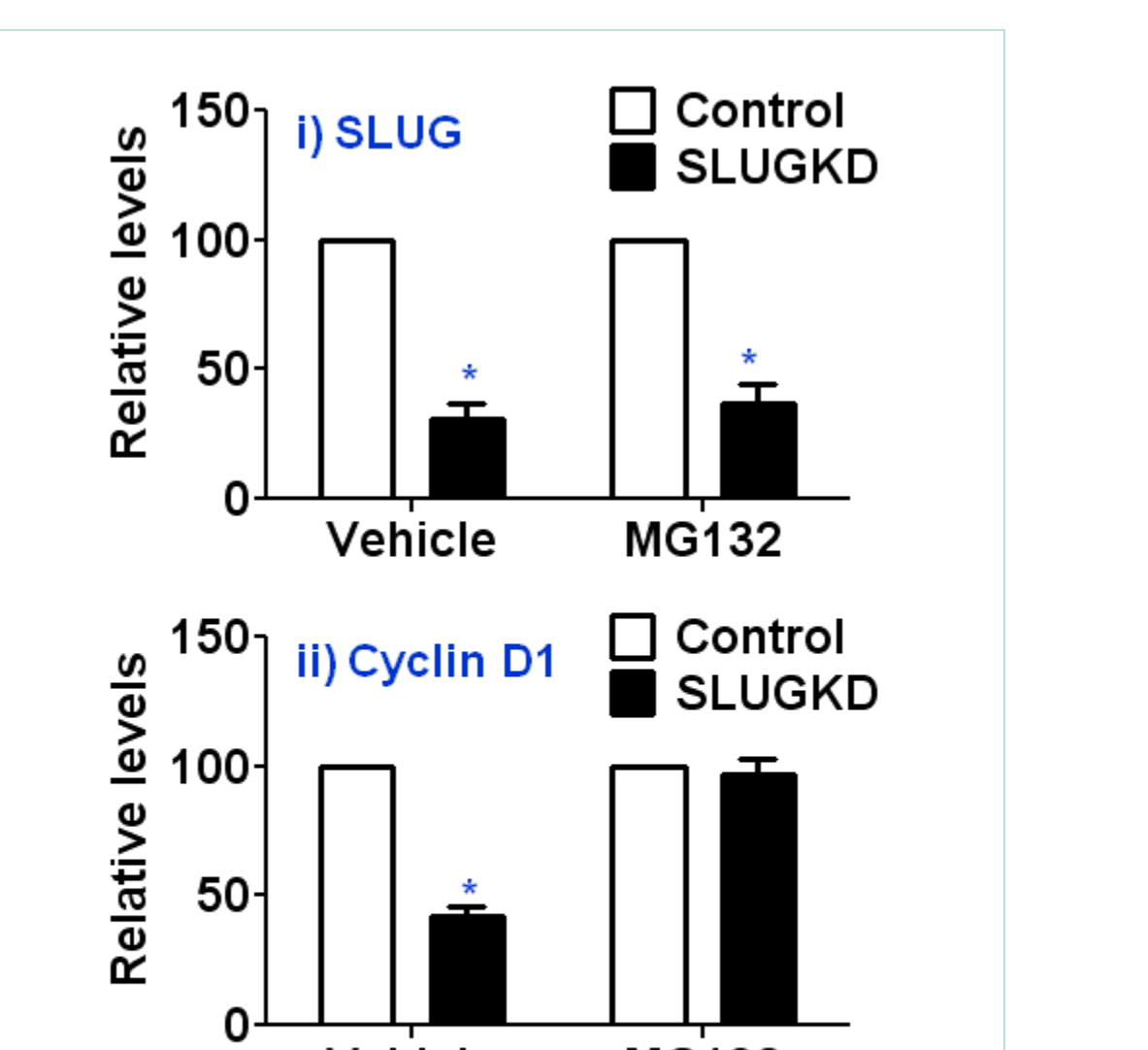

Fig. 16. Effect of the proteasome inhibitor MG132 on the decrease in cyclin D1 in SLUG-knockdown (SLUGKD) MDA-MB-231 cells. Vehicle: DMSO.

Fig. 17. Effect of knockdown of UbcH5c on cyclin D1 levels in MDA-MB-468 and MCF7 cells. (A) Immunoblot analysis showing the effect of knockdown of UbcH5c (H5cKD) on cyclin D1 level in MDA-MB-468 cells. Control cells were transfected with control siRNA. (B) Immunoblot analysis showing the effect of knockdown of UbcH5c (H5cKD) on cyclin D1 level in MCF7 cells.

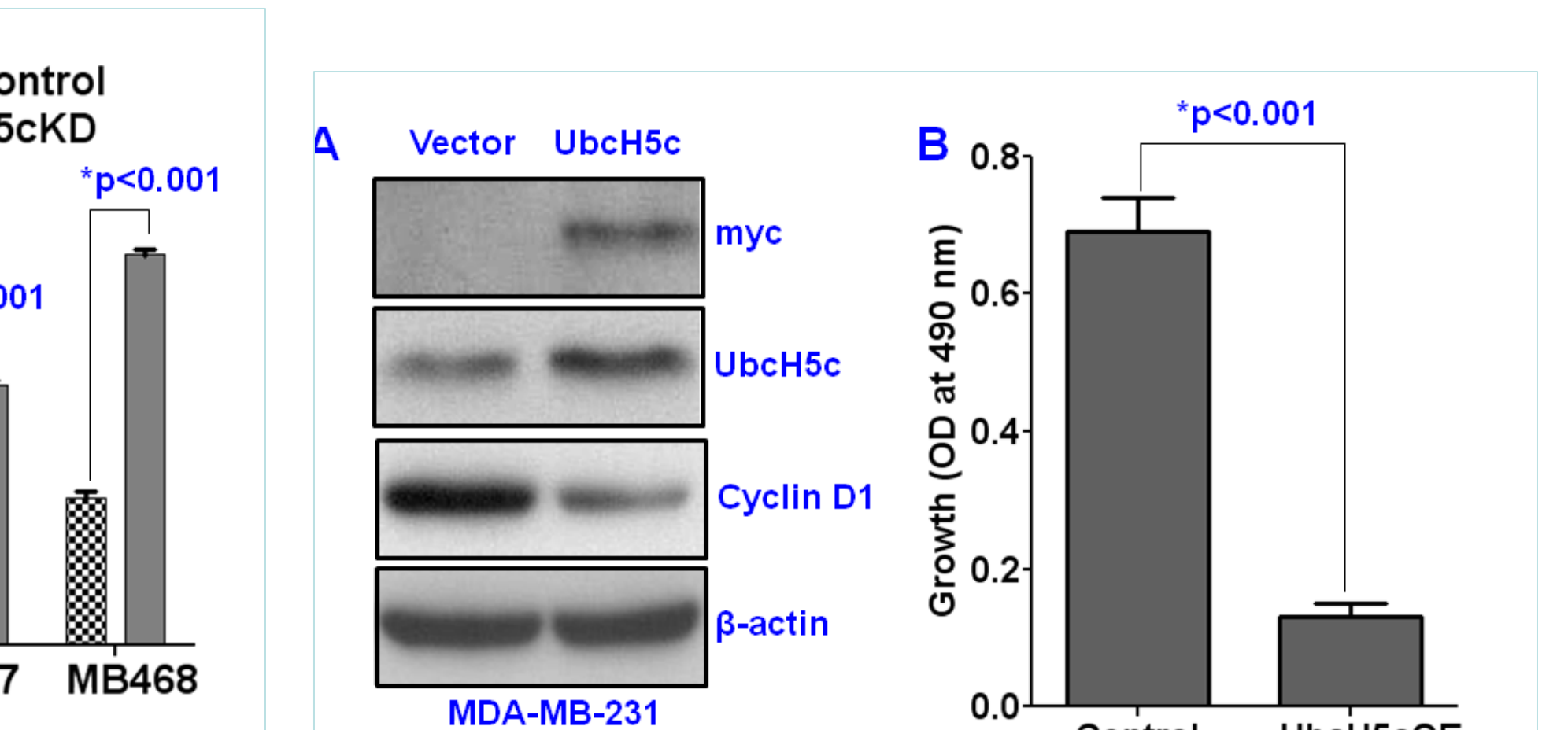
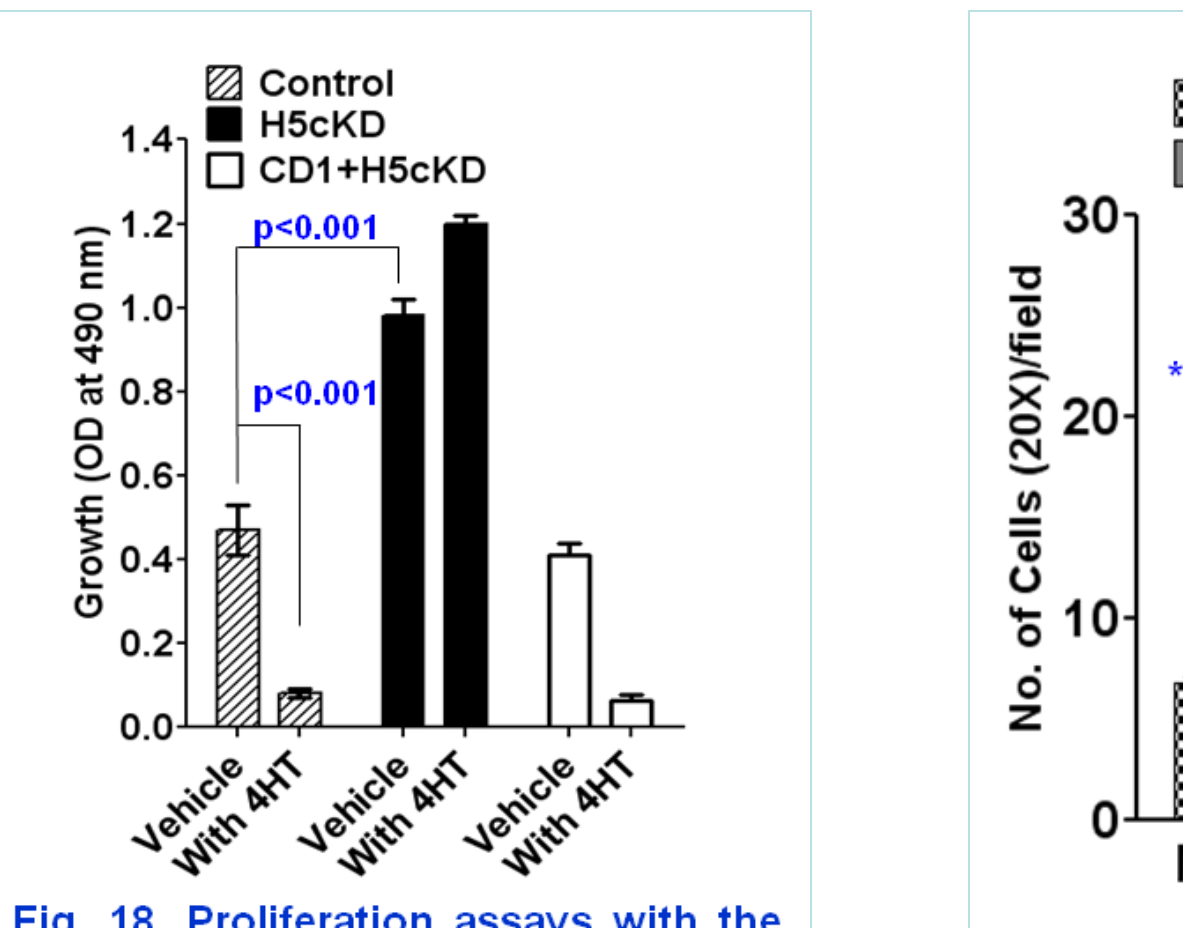

Fig. 18. Proliferation assays with the control and UbcH5c knockdown (H5cKD) MCF7 cells in the absence or presence of 4HT (10 μ M) and the effects of simultaneous knockdown of cyclin D1 (CD1+H5cKD) in these processes.

Fig. 19. Matrigel invasion assay with UbcH5c knockdown (H5cKD) MCF7 and MDA-MB-468 cells. Results are mean \pm SEM (n=6).

Our recent publication on this topic
Mittal M. K., Singh, K., Misra, S. and Chaudhuri, G. (2011) SLUG-induced elevation of D1 cyclin in breast cancer through the inhibition of its ubiquitination. J. Biol. Chem. 286, 469-479.

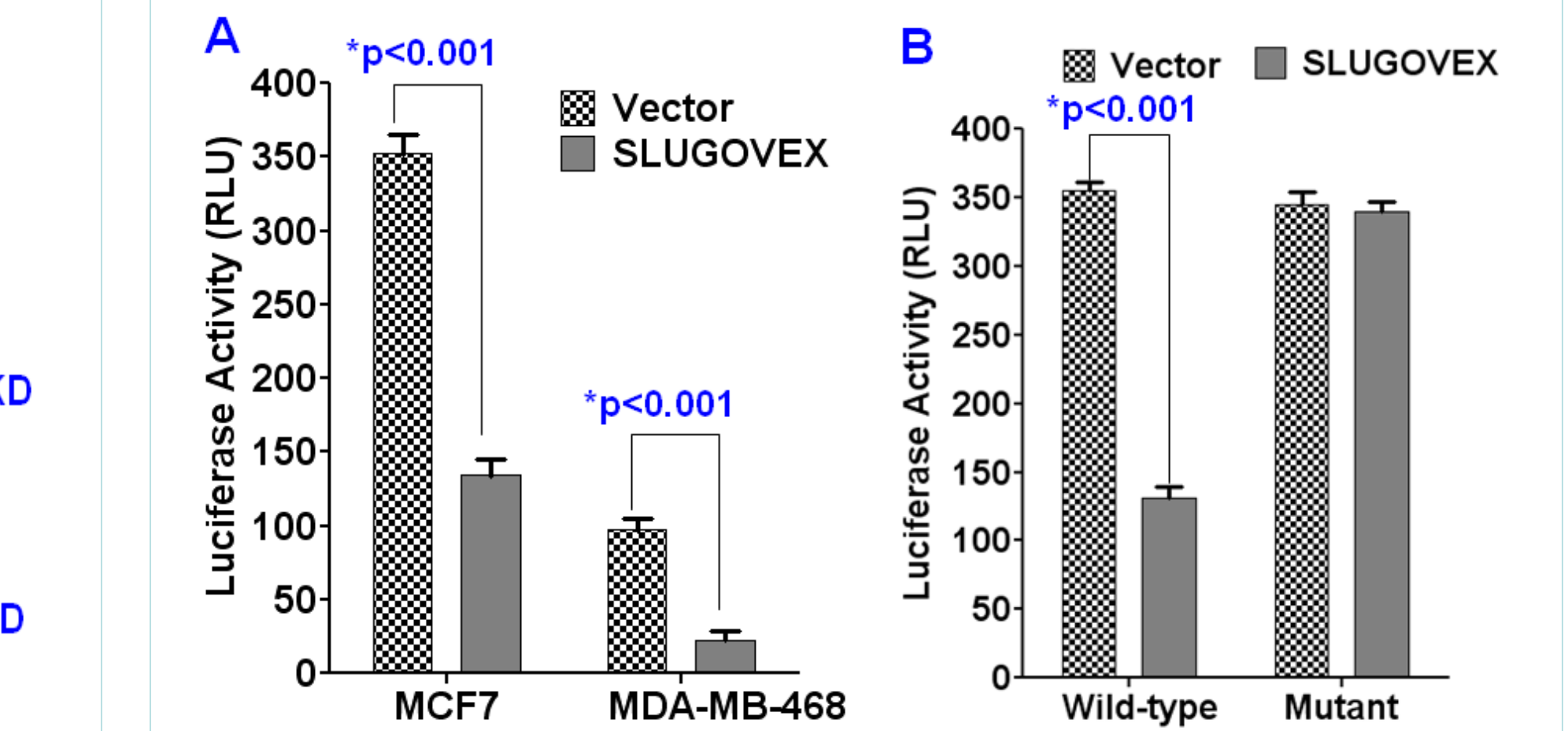
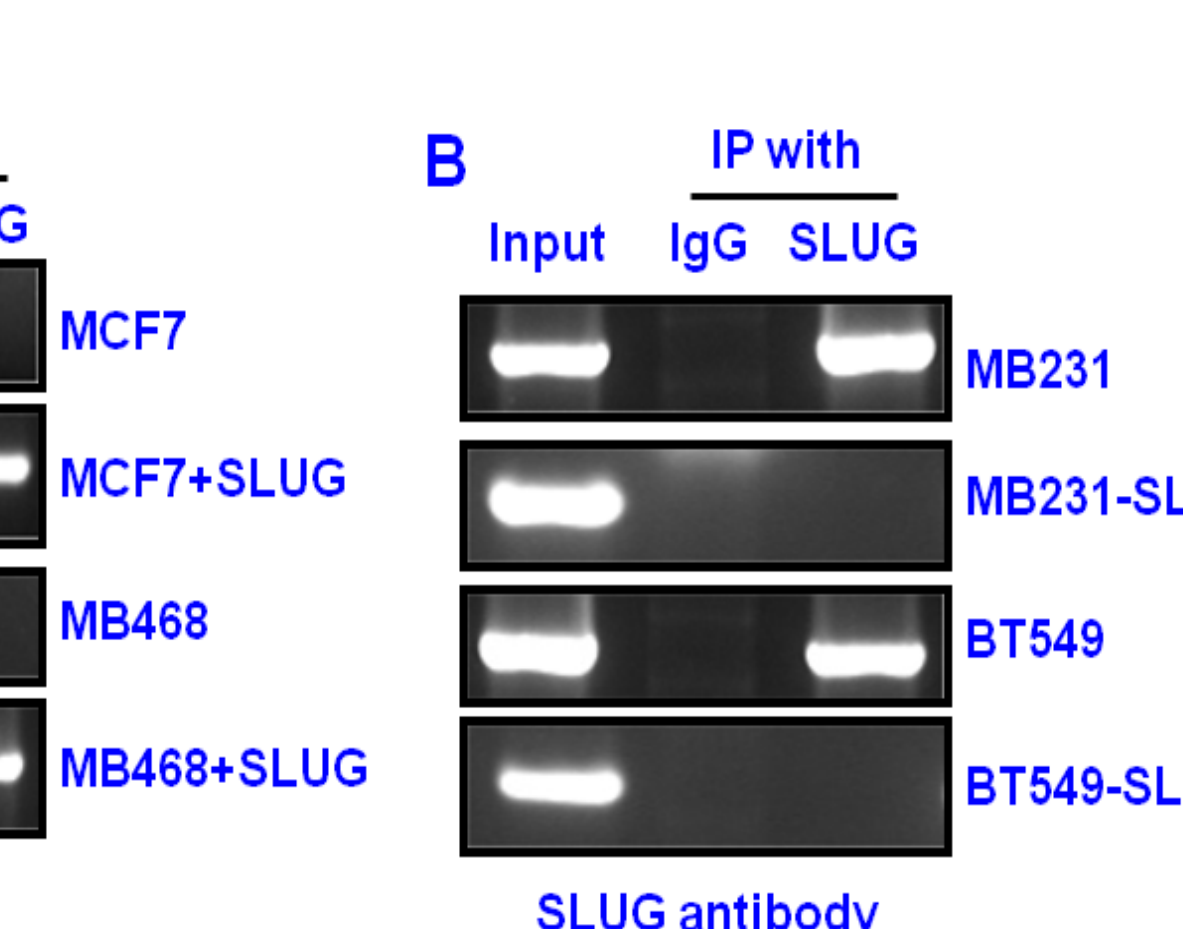

Fig. 21. *In vivo* binding of SLUG to UbcH5c gene promoter. (A) ChIP analysis for the binding of SLUG to the promoter of UbcH5c gene in FLAG-tagged SLUG-expressing (+SLUG) MCF7 and MDA-MB-468 cells. (B) ChIP analysis for the binding of SLUG to the promoter of UbcH5c gene in the control and the SLUG knockdown MDA-MB-231 and BT549 (-SLUGKD) cells.

Fig. 22. Characterization of UbcH5c gene promoter. (A) Repression of UbcH5c promoter in the SLUG-expressing (SLUGOVEX) MCF7 and MDA-MB-468 cells. (B) Effect of E2-box mutation at UbcH5c promoter on its activity in SLUG-expressing (SLUGOVEX) MCF7 cells. Results are mean \pm SEM (n=6). Decrease in the luciferase activities were statistically significant (p<0.001).

CONCLUSIONS

- ✦ SLUG-high basal type triple negative breast cancer (TNBC) cells such as MDA-MB-231 and BT549 have high levels of cyclin D1 which may explain their high growth rate.
- ✦ Knockdown of SLUG in TNBC cells increased ubiquitination of cyclin D1 and its proteasomal degradation.
- ✦ SLUG helps maintain high levels of cyclin D1 in the TNBC cells through the inhibition of the transcription of cyclin D1-degrading ubiquitin conjugating enzyme UbcH5c (Ube2D3).
- ✦ SLUG binds to the promoter of *UbcH5c* gene to execute its function.
- ✦ Cyclin D1 binds to ER and prevent binding of tamoxifen to the receptor thereby stimulate ER signal transduction pathway in SLUG expressing malignant ER-positive breast cancer cells.
- ✦ Since UbcH5c behaves like a tumor suppressor, we postulate that measures to boost up UbcH5c levels in the TNBC cells by treatments with SLUG inhibitors and all-trans retinoic acid (which increases UbcH5c gene expression) should kill these cells.

RESEARCH FUNDED BY

Research funded by the DOD-CDMRP IDEA Grant# BC050641 to GC.