

# **Patent Prosecution Highway Pilot Program between the United States Patent and Trademark Office and the European Patent Office based on Patent Cooperation Treaty Work Products**

## **I. Background**

The United States Patent and Trademark Office (USPTO) and the European Patent Office (EPO) began a Patent Prosecution Highway (PPH) pilot program on September 29, 2008. The pilot program was extended on September 30, 2009, for one year until September 30, 2010. See “Patent Prosecution Highway Pilot Program between the United States Patent and Trademark Office and European Patent Office,” published on October 21, 2008, at 1335 OG 196 and “Continuation of the Patent Prosecution Highway Pilot Program between the USPTO and EPO,” published on October 20, 2009, at 1347 OG 170. Under this prior PPH pilot program, an applicant receiving a determination from the EPO that at least one claim in a European application is allowable/patentable may request that a corresponding application filed in the USPTO be accorded special status and be advanced out of turn for examination. This prior PPH pilot program was limited to the utilization of search and examination results of national applications between cross filings under the Paris Convention.

At the November 2009 Trilateral Conference, as part of a Trilateral effort, the Trilateral Offices (USPTO, EPO and the Japan Patent Office (JPO)) agreed to launch a new PPH pilot program based on Patent Cooperation Treaty (PCT) work products (PCT-PPH pilot program). The PCT-PPH pilot program will greatly expand the potential of the PPH program. This notice sets forth the requirements and details for the PCT-PPH pilot program between the USPTO and the EPO. For the requirements and details for the PCT-PPH pilot program between the USPTO and the JPO, see the corresponding notice entitled “Patent Prosecution Highway Pilot Program between the United States Patent and Trademark Office and the Japan Patent Office based on Patent Cooperation Treaty Work Products.”

By permitting the USPTO to draw upon positive PCT work products from the EPO, the PPH program will now be available to a larger number of applicants.

## **II. PCT-PPH Pilot Program**

The PCT-PPH pilot program was established to enable an applicant, who has received

- (1) a Written Opinion from an International Searching Authority (WO/ISA) (ISA must be the EPO or the USPTO), or
- (2) a Written Opinion from an International Preliminary Examining Authority (WO/IPEA) (IPEA must be the EPO or the USPTO), or
- (3) an International Preliminary Examination Report (IPER) from an International Preliminary Examining Authority (IPEA must be the EPO or the USPTO),

that indicates at least one claim in the PCT application has novelty, inventive step and industrial applicability, to file a request to participate in the PCT-PPH pilot program in a corresponding U.S. application and petition to make the U.S. application special under the PCT-PPH pilot program. Note that the procedures for a petition to make special under the accelerated examination program set forth in MPEP 708.02(a) do NOT apply to a petition to make special under the PCT-PPH pilot program. The procedures and requirements for filing a request in the USPTO for participation in the PCT-PPH pilot program are set forth below.

#### **A. Trial Period for the PCT-PPH Pilot Program**

The PCT-PPH pilot program will commence on January 29, 2010, for a period of two years ending on January 28, 2012. The trial period may be extended if necessary until the USPTO and the EPO receive a sufficient number of PPH requests to adequately assess the feasibility of the PCT-PPH pilot program. The USPTO and the EPO may also terminate the PCT-PPH pilot program early if the volume of participation exceeds a manageable level, or for any other reasons. Notice will be published if the PCT-PPH pilot program will be terminated before the January 28, 2012 date.

#### **B. Requirements for Requesting Participation in the PCT-PPH Pilot Program in the USPTO**

In order to be eligible to participate in the PCT-PPH pilot program, the following conditions must be met:

(1) The relationship between the corresponding U.S. application for which participation in the PCT-PPH pilot program is requested and the PCT application satisfies one of the following requirements (note that RO/-- as used in the diagrams below refers to an international application filed under the PCT in any competent receiving office):

(a) The U.S. application is a national stage entry of the corresponding PCT application. See diagrams (A), (A') and (A'') below.

**(A) The U.S. application is a national stage entry of the corresponding PCT application.**

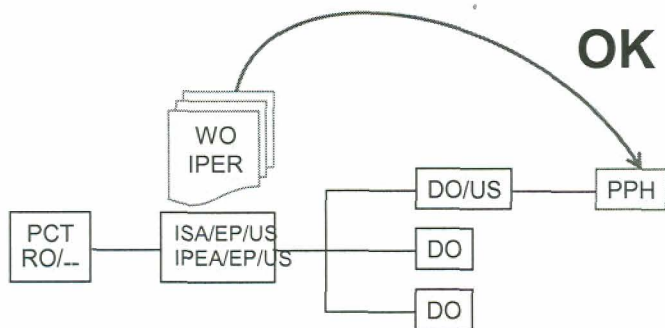

**(A') The U.S. application is a national stage entry of the corresponding PCT application.**

**(The corresponding PCT application claims priority to a national application filed anywhere.)**

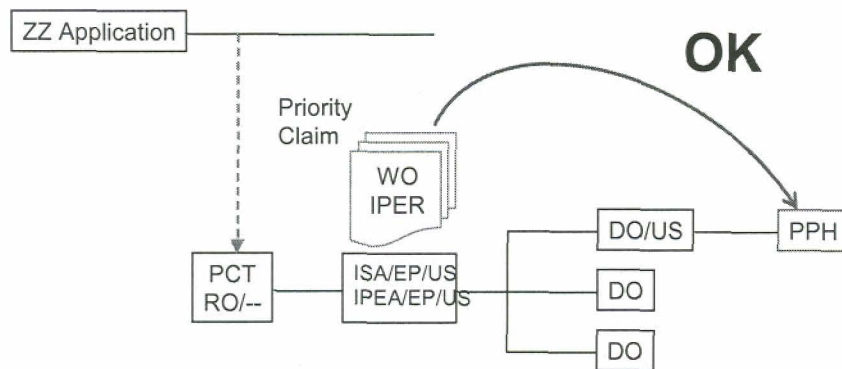

(A'') The U.S. application is a national stage entry of the corresponding PCT application.  
(The corresponding PCT application claims priority to another PCT application.)

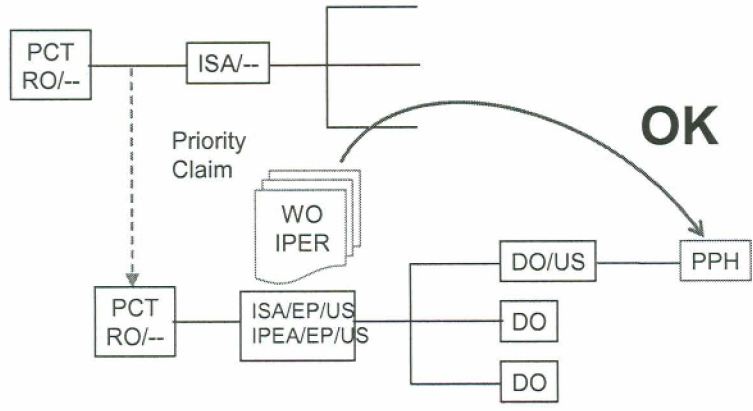

(b) The U.S. application is a national application which forms the basis for the priority claim in the corresponding PCT application. See diagram (B) below.

Provisional applications, plant applications, design applications, reissue applications and applications subject to a secrecy order (35 U.S.C. 181) are excluded and not subject to participation in the PCT-PPH pilot program.

**(B) The U.S. application is a national application which forms the basis for the priority claim in the corresponding PCT application.**

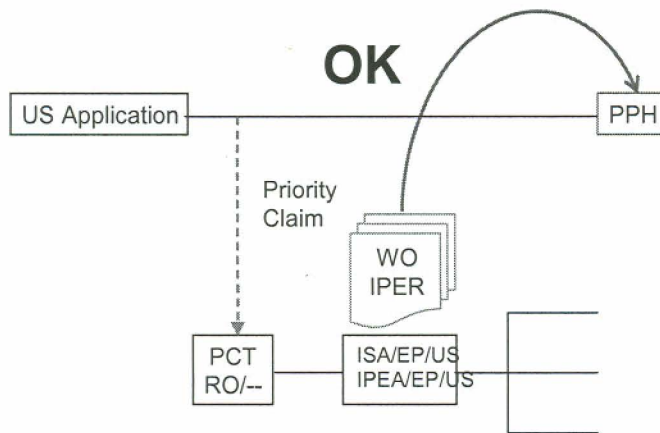



(c) The U.S. application is a national stage entry of another PCT application (which can be filed in any competent receiving office) which claims priority to the corresponding PCT application. See diagram (C) below.

**(C) The U.S. application is a national stage entry of a PCT application which claims priority to the corresponding PCT application.**

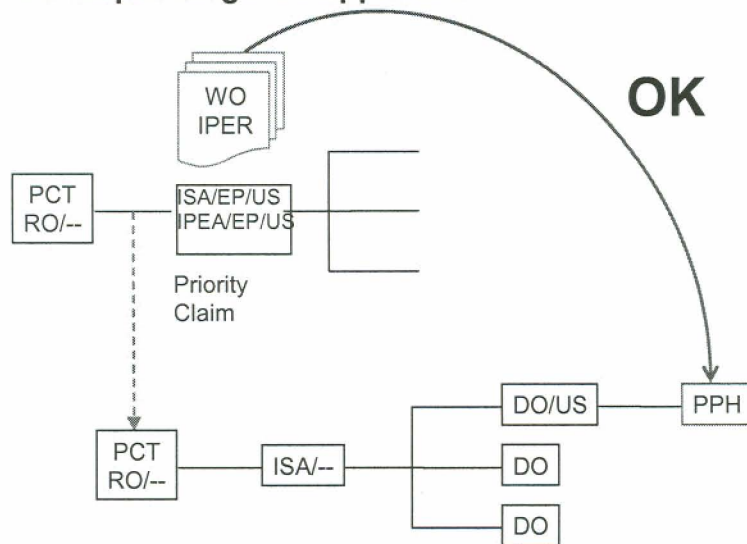

(d) The U.S. application is a national application claiming foreign/domestic priority to the corresponding PCT application. See diagram (D) below.

Design applications and applications subject to a secrecy order (35 U.S.C. 181) are excluded and not subject to participation in the PCT-PPH pilot program.

**(D) The U.S. application is a national application claiming foreign/domestic priority to the corresponding PCT application.**

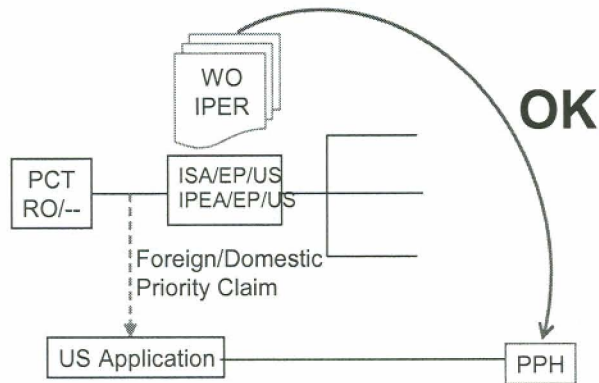

(e) The U.S. application is a continuing application (continuation, divisional, or continuation-in-part) of the U.S. application which satisfies one of the above (a) to (d) scenarios. See diagrams (E1) and (E2) below.

Plant applications, design applications and applications subject to a secrecy order (35 U.S.C. 181) are excluded and not subject to participation in the PCT-PPH pilot program.

**(E1) The U.S. application is a continuing application of an application which satisfies the requirement (a).**

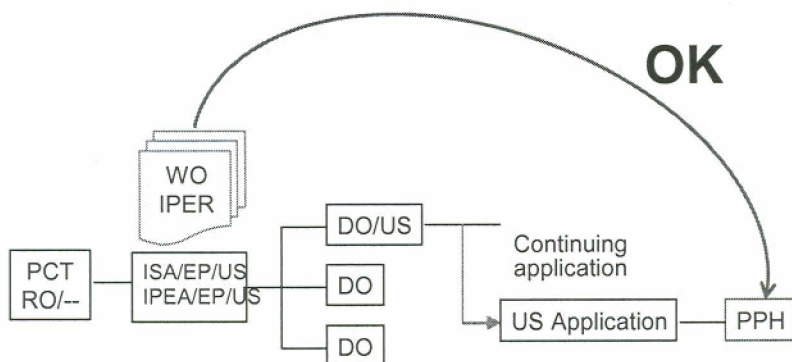

**(E2) The U.S. application (US2) is an application claiming Domestic priority to an application (US1) which satisfies the requirement (b).**

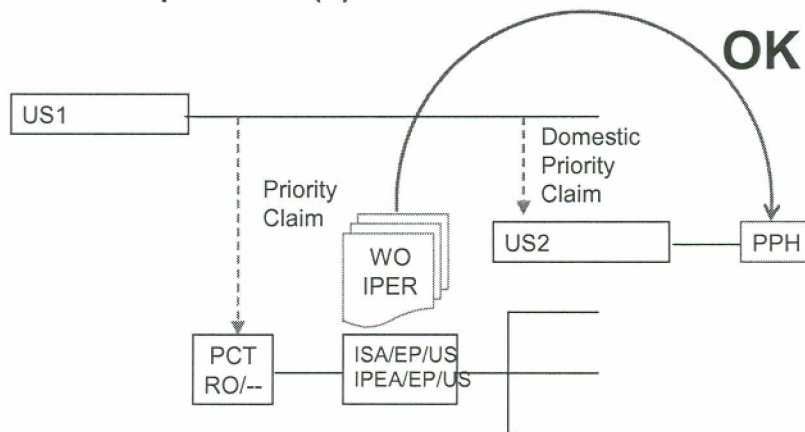



In diagram (E2), US2 application may be a non-provisional application claiming benefit under 35 U.S.C. 119(e) to a provisional application (US1).

(2) The latest work product in the international phase of the PCT application corresponding to the U.S. application, namely the WO/ISA, or the WO/IPEA, or the IPER, indicates at least one claim in the PCT application has novelty, inventive step and industrial applicability. In case any observation is described in Box VIII of the WO/ISA, or WO/IPEA, or IPER which forms the basis for the PCT-PPH request, applicant must identify and explain why the claim(s) is/are not subject to any observation described in Box VIII irrespective of whether an amendment is submitted to correct the observation described in Box VIII. The U.S. application will not be eligible to participate in the PCT-PPH pilot program if applicant does not identify and explain why the claim(s) is/are not subject to the observation described in Box VIII.

Note that the ISA and the IPEA which produced the WO/ISA, WO/IPEA and the IPER are limited to the EPO or the USPTO. Where the JPO is the ISA and/or IPEA and applicant wishes to participate in the PCT-PPH pilot program, see the corresponding notice entitled "Patent Prosecution Highway Pilot Program between the United States Patent and Trademark Office and the Japan Patent Office based on Patent Cooperation Treaty Work Products."

Applicant may not file a request to participate in the PCT-PPH pilot program on the basis of an International Search Report (ISR) only.

### (3) Claim Correspondence

(a) All the claims in each U.S. application for which a request for participation in the PCT-PPH pilot program is made must sufficiently correspond to or be amended to sufficiently correspond to one or more of those claims indicated as having novelty, inventive step and industrial applicability and free of any observation described in Box VIII in the latest work product of the corresponding PCT application.

(b) Claims are considered to "sufficiently correspond" where, accounting for differences due to translations and claim format requirements, the claims in the U.S. application are of the same or similar scope as the claims indicated as having novelty, inventive step and industrial applicability and free of any observation described in Box VIII in the latest work product of the corresponding PCT application, or the claims in the U.S. application are narrower in scope than the claims indicated as having novelty, inventive step and industrial applicability and free of any observation described in Box VIII in the latest work product of the corresponding PCT application.

(c) In this regard, a claim that is narrower in scope occurs when a claim indicated as having novelty, inventive step and industrial applicability and free of any observation described in Box VIII in the latest work product of the corresponding PCT application is amended to be further limited by an additional feature that is supported

in the written description of the U.S. application. The claim(s) with the narrower scope must be written in dependent form in the U.S. application for which participation in the PCT-PPH pilot program is requested.

(4) Substantive examination of the U.S. application for which participation in the PCT-PPH pilot program is requested has not begun.

(5) Applicant must file a request for participation in the PCT-PPH pilot program and a petition to make the U.S. application special under the PCT-PPH pilot program. A sample request/petition form (PTO/SB/20PCT-EP) will be available from the USPTO Web site at <http://www.uspto.gov> on January 29, 2010. Applicants are encouraged to use the USPTO request/petition form. A petition fee under 37 CFR 1.17(h) for the petition to make special under 37 CFR 1.102(d) is required and must be submitted.

(6) Unless already filed in the U.S. application for which participation in the PCT-PPH pilot program is requested, applicant must submit a copy of the latest international work product, WO/ISA, or WO/IPEA or IPER, which indicated that the claim(s) has/have novelty, inventive step and industrial applicability along with an English translation thereof if the copy of the latest international work product is not in the English language. A statement that the English translation is accurate is not required. Where the required documents have been previously filed in the U.S. application, applicant may simply refer to these documents and indicate in the request for participation in the PCT-PPH pilot program when these documents were previously filed in the U.S. application. Where the U.S. application and the corresponding PCT application satisfy the relationship noted in B.(1)(a) above, applicant need not submit a copy of the latest international work product along with an English translation thereof since a copy of these documents is already contained in the file wrapper of the U.S. application.

(7) Unless already filed in the U.S. application for which participation in the PCT-PPH pilot program is requested, applicant must submit a copy of the claims from the corresponding PCT application which were indicated as having novelty, inventive step and industrial applicability in the latest work product of the PCT application along with an English translation thereof and a statement that the English translation is accurate if the claims are not in the English language. Where the required documents have been previously filed in the U.S. application, applicant may simply refer to these documents and indicate in the request for participation in the PCT-PPH pilot program when these documents were previously filed in the U.S. application. If the claims in the U.S. application for which participation in the PCT-PPH pilot program is requested are identical to the claims from the corresponding PCT application, and are in the English language, applicant may just indicate such in the PCT-PPH request and it will not be necessary for applicant to submit a copy of the claims from the corresponding PCT application.

(8) Applicant is required to submit a claims correspondence table in English. The claims correspondence table must indicate how all the claims in the U.S. application sufficiently



correspond to the claims indicated as having novelty, inventive step and industrial applicability in the latest international work product.

(9) Applicant must submit an information disclosure statement (IDS) listing the documents cited in the international work products (ISR, WO/ISA, WO/IPEA, IPER) of the PCT application corresponding to the U.S. application for which participation in the PCT-PPH pilot program is requested (unless such an IDS has already been filed in the U.S. application, applicant may simply refer to the previously filed IDS and indicate in the request for participation in the PCT-PPH pilot program when the IDS was previously filed in the U.S. application). Applicant must submit copies of all the documents cited in the international work products of the PCT application corresponding to the U.S. application (unless the copies have already been filed in the U.S. application, applicant may simply refer to the previously filed copies of the documents and indicate in the request for participation in the PCT-PPH pilot program when the copies were previously filed in the U.S. application) except U.S. patents or U.S. patent application publications.

(10) The request for participation in the PCT-PPH pilot program and all the supporting documents must be submitted to the USPTO via EFS-Web and indexed with the following document description: "Petition to make special under PCT-Patent Pros Hwy." Information regarding EFS-Web is available at [http://www.uspto.gov/ebc/efs\\_help.html](http://www.uspto.gov/ebc/efs_help.html). Any preliminary amendments and IDS submitted with the PCT-PPH documents must be separately indexed as a preliminary amendment and IDS, respectively.

Where the request for participation in the PCT-PPH pilot program and special status are granted, applicant will be notified and the U.S. application will be advanced out of turn for examination. In those instances where the request for participation in the PCT-PPH pilot program does not meet all the requirements set forth above, applicant will be notified and the defects in the request will be identified. Applicant will be given one opportunity to perfect the request in a renewed request for participation (which must be submitted via EFS-Web and indexed accordingly as noted above). Note that action on the application by the examiner will NOT be suspended (37 CFR 1.103) awaiting a reply by the applicant to perfect the request in a renewed request for participation. That is, if the application is picked up for examination by the examiner after applicant has been notified of the defects in the request, any renewed request will be dismissed. If the renewed request is perfected and examination has not begun, the request and special status will be granted, applicant will be notified and the U.S. application will be advanced out of turn for examination. If not perfected, applicant will be notified and the application will await action in its regular turn.

Request for participation in the PPH pilot program and special status granted in a parent application will not carry over to a continuing application. Applicant must fulfill all the conditions set forth above in order for special status to be granted in the continuing application.

### C. Special Examining Procedures

Once the request for participation in the PCT-PPH pilot program and special status have been granted to the U.S. application, the U.S. application will be taken up for examination by the U.S. examiner before all other categories of applications except those clearly in condition for allowance, those with set time limits, such as examiner's answers, and those that have been granted special status for "accelerated examination."

Any claims amended or added after the grant of the request for participation in the PCT-PPH pilot program must "sufficiently correspond" to the claims indicated as having novelty, inventive step and industrial applicability in the latest work product of the corresponding PCT application. See the definition of "sufficient correspondence" in II.B.(3) above. Applicant is required to submit a claims correspondence table along with the amendment (see II.B.(8) above). If the amended or newly added claims do not sufficiently correspond to the claims indicated as having novelty, inventive step and industrial applicability in the latest work product of the corresponding PCT application, the amendment will not be entered and will be treated as a non-responsive reply.

The PCT-PPH program does not absolve applicants of all their duties under 37 CFR 1.56 and 37 CFR 11.18. By complying with requirements II.B.(6) and (9) identified above, applicants would be considered to have complied with their duties to bring to the attention of the USPTO any material prior art cited in the corresponding PCT application (see MPEP § 2001.06(a)). Applicants still have a duty of candor and good faith, including providing to the USPTO other information known to them to be material to patentability.

Any inquiries concerning this notice may be directed to Magdalen Greenlief, Office of the Associate Commissioner for Patent Examination Policy, at 571-272-8800 or at [magdalen.greenlief@uspto.gov](mailto:magdalen.greenlief@uspto.gov).

Date: 1/28/10

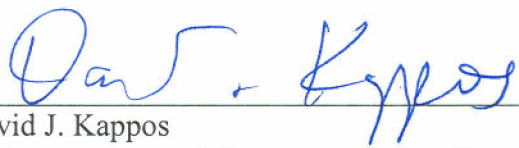
  
\_\_\_\_\_  
David J. Kappos  
Under Secretary of Commerce for Intellectual Property and  
Director of the United States Patent and Trademark Office