



**BEXAR COUNTY FIRE MARSHAL
AND EMERGENCY MANAGEMENT OFFICE**

203 W. NUEVA, SUITE 302
SAN ANTONIO, TEXAS 78207-4505
TEL: 210.335.0300 FAX: 210.335.0330



**Rules for the Enforcement of the
International Fire Code and International Building Code**

In the following document, an underlined word or sentence is a Bexar County regulation that has been added; a ~~strike-through~~ is a word or sentence removed as a Bexar County regulation.

2009 International Fire Code Rules: Changes affecting any code section will be displayed under the appropriate section.

CHAPTER 1 - ADMINISTRATION 3

 SECTION 103 – DEPARTMENT OF FIRE PREVENTION3

 SECTION 104 - GENERAL AUTHORITY AND RESPONSIBILITIES3

 SECTION 105 - PERMITS4

 SECTION 106 - INSPECTIONS5

 SECTION 108 - BOARD OF APPEALS5

 SECTION 109 - VIOLATIONS5

 SECTION 110 - UNSAFE BUILDINGS6

 SECTION 111 - STOP WORK ORDER6

CHAPTER 2 - DEFINITIONS6

 SECTION 202 - GENERAL DEFINITIONS6

CHAPTER 3 - GENERAL PRECAUTIONS AGAINST FIRE7

 SECTION 308 - OPEN FLAMES7

 SECTION 311 - VACANT PREMISES7

 SECTION 315 - MISCELLANEOUS COMBUSTIBLE MATERIALS STORAGE7

CHAPTER 4 - EMERGENCY PLANNING AND PREPAREDNESS7

 SECTION 403 - PUBLIC ASSEMBLAGES AND EVENTS7

 SECTION 404 - FIRE SAFETY AND EVACUATION PLANS8

 SECTION 405 - EMERGENCY EVACUATION DRILLS8

 SECTION 408 - USE AND OCCUPANCY-RELATED REQUIREMENTS8

CHAPTER 5 - FIRE SERVICE FEATURES9

 SECTION 501 - GENERAL9

 SECTION 503 - FIRE APPARATUS ACCESS ROADS10

 SECTION 505 - PREMISES IDENTIFICATION13

 SECTION 506 - KEY BOXES13

 SECTION 507 - FIRE PROTECTION WATER SUPPLIES14

 SECTION 510 – CITY OF SAN ANTONIO/BEXAR COUNTY EMERGENCY RESPONDER RADIO COVERAGE15

CHAPTER 6- BUILDING SERVICES AND SYSTEMS17

 SECTION 609 – COMMERCIAL KITCHEN HOODS17

CHAPTER 7- FIRE-RESISTANCE-RATED CONSTRUCTION.....17

 SECTION 703 - FIRE-RESISTANCE-RATED CONSTRUCTION17

CHAPTER 8 - INTERIOR FINISH, DECORATIVE MATERIALS AND FURNISHINGS17

 SECTION 807 - DECORATIVE MATERIALS OTHER THAN DECORATIVE VEGETATION IN NEW AND EXISTING BUILDINGS17

CHAPTER 9 - FIRE PROTECTION SYSTEMS17

 SECTION 901 - GENERAL17

 SECTION 903 - AUTOMATIC SPRINKLER SYSTEMS18

 SECTION 904 – ALTERNATIVE AUTOMATIC FIRE-EXTINGUISHING SYSTEMS18

 SECTION 907 - FIRE ALARM AND DETECTION SYSTEMS18

 SECTION 912 - FIRE DEPARTMENT CONNECTIONS20

CHAPTER 10 - MEANS OF EGRESS21

 [B] SECTION 1004 - OCCUPANT LOAD21

 [B] SECTION 1006 - MEANS OF EGRESS ILLUMINATION21

 [B] SECTION 1008 - DOORS, GATES AND TURNSTILES21

CHAPTER 23 - HIGH-PILED COMBUSTIBLE STORAGE22

 SECTION 2305 - HOUSEKEEPING AND MAINTENANCE22

CHAPTER 27 - HAZARDOUS MATERIALS—GENERAL PROVISIONS	22
SECTION 2703 - GENERAL REQUIREMENTS	22
CHAPTER 29 - COMBUSTIBLE FIBERS	22
SECTION 2906 - CONSTRUCTION AND PROTECTION REQUIREMENTS.....	22
CHAPTER 33 – EXPLOSIVES AND FIREWORKS	23
CHAPTER 34 - FLAMMABLE AND COMBUSTIBLE LIQUIDS.....	23
SECTION 3401 - GENERAL	23
SECTION 3403 - GENERAL REQUIREMENTS	23
SECTION 3404 – STORAGE	23
CHAPTER 46 - CONSTRUCTION REQUIREMENTS FOR EXISTING BUILDINGS.....	23
CHAPTER 4601 - GENERAL	23
APPENDIX A.....	24
SECTION A101 – GENERAL	24
APPENDIX D	25
SECTION D103 - MINIMUM SPECIFICATIONS.....	25

2009 International Building Code Rules: Changes affecting any code section will be displayed under the appropriate section.

CHAPTER 1 - ADMINISTRATION	27
SECTION 103 - FIRE CODE ENFORCEMENT SECTION DEPARTMENT OF BUILDING SAFETY	27
SECTION 104 - DUTIES AND POWERS OF BUILDING OFFICIAL	27
SECTION 105 - PERMITS AND WORK AUTHORIZATIONS	27
SECTION 108 – TEMPORARY STRUCTURES AND USES	28
SECTION 109 - FEES.....	28
SECTION 110 - INSPECTIONS	29
SECTION 111 - CERTIFICATE OF COMPLIANCE OR OCCUPANCY	29
SECTION 113 - BOARD OF APPEALS	29
SECTION 114 - VIOLATIONS.....	29
CHAPTER 2 – DEFINITIONS	30
SECTION 202 - GENERAL DEFINITIONS	30
CHAPTER 5 - GENERAL BUILDING HEIGHTS AND AREAS	30
SECTION 501 - GENERAL	30
CHAPTER 9 - FIRE PROTECTION SYSTEMS	31
SECTION 903 - AUTOMATIC SPRINKLER SYSTEMS	31
SECTION 904 – ALTERNATIVE AUTOMATIC FIRE-EXTINGUISHING SYSTEMS	31
SECTION 907 - FIRE ALARM AND DETECTION SYSTEMS.....	31
CHAPTER 10 - MEANS OF EGRESS	34
[B] SECTION 1004 - OCCUPANT LOAD	34
SECTION 1008 - DOORS, GATES AND TURNSTILES	34
SECTION 1026 - EXTERIOR EXIT RAMPS AND STAIRWAYS.....	34
CHAPTER 11- ACCESSIBILITY	34
SECTION 1102 - DEFINITIONS.....	34
CHAPTER 15 - ROOF ASSEMBLIES AND ROOFTOP STRUCTURES	35
SECTION 1503 - WEATHER PROTECTION.....	35
CHAPTER 17 - STRUCTURAL TESTS AND SPECIAL INSPECTIONS	35
SECTION 1704 - SPECIAL INSPECTIONS.....	35
SPECIAL NOTES CONCERNING FIRE ALARM DEVICES.....	36

Rules for the Enforcement of the International Fire Code and International Building Code

In the following document, an underlined word or sentence is a Bexar County regulation that has been added; a ~~strike-through~~ is a word or sentence removed as a Bexar County regulation.

The following Sections of the 2009 International Fire Code shall read as follows:

2009 International Fire Code Rules: Changes affecting any code section will be displayed under the appropriate section.

CHAPTER 1 - ADMINISTRATION

SECTION 103 – DEPARTMENT OF FIRE PREVENTION

103.1 General. The department of fire prevention is established within the jurisdiction under the direction of the fire code official. The function of the department shall be the implementation, administration and enforcement of the provisions of this code.

103.1.1 FIRE CODE OFFICIAL – DEFINED.

Throughout the 2009 International Fire Code, where the term fire code official is used, it shall mean the Bexar County Fire Marshal.

103.1.2 FIRE CODE ENFORCEMENT & FIRE PREVENTION SECTION – DEFINED.

Throughout the 2009 International Fire Code, where the term department of fire prevention is used, it shall mean the Bexar County Fire Marshal's Office, Fire Code Enforcement and Fire Prevention Sections.

SECTION 104 - GENERAL AUTHORITY AND RESPONSIBILITIES

104.1 General. The fire code official is hereby authorized to enforce the provisions of this code and shall have the authority to render interpretations of this code, and to adopt policies, procedures, rules and regulations in order to clarify the application of its provisions. Such interpretations, policies, procedures, rules and regulations shall be in compliance with the intent and purpose of this code and shall not have the effect of waiving requirements specifically provided for in this code.

104.1.1 Authority of the Fire Marshal and the Fire Marshal's Office. It shall be the duty of the Fire Marshal and he is hereby given the necessary power to do whatever may be deemed necessary by him for the safety and protection of property and citizens from fire hazards, to include the issuance of Notices of Violation

and Citations as required to achieve compliance with the Fire and/or Building Codes. The Fire Marshal may delegate his power to any other member of the Fire Marshal's Office.

104.3 Right of entry. Whenever it is necessary to make an inspection to enforce the provisions of this code, or whenever the fire code official has reasonable cause to believe that there exists in a building or upon any premises any conditions or violations of this code which make the building or premises unsafe, dangerous or hazardous, fire code official shall have the authority to enter the building or premises at all reasonable times to inspect or to perform the duties imposed upon the fire code official by this code. If such building or premises is occupied, the fire code official shall present credentials to the occupant and request entry. If such building or premises is unoccupied, the fire code official shall first make a reasonable effort to locate the owner or other person having charge or control of the building or premises and request entry. If entry is refused, the fire code official has recourse to every remedy provided by law to secure entry. No owner or occupant or any other person having charge, care or control of any building shall fail or neglect, after proper demand is made as herein provided, to properly permit entry by the Fire Marshal or his authorized representatives for the purpose of inspection or examination under such exigent circumstances affecting the safety of persons and/or property, or to take such prudent action to abate a fire hazard.

104.3.2 Photographic Documentation. Members of the Fire Marshal's Office making such examinations or inspections shall have the right, with proper credentials, and be authorized to take a reasonable number of photographs or video recordings for evidence and for records for use by the Fire Marshal's Office to document and study fire hazards and scientific control for fire safety.

104.11 Authority at fires and other emergencies. The Fire Marshal, fire chief or officer of the fire department in charge at the scene of a fire or other emergency involving the protection of life or property or any part thereof, shall have the authority to direct such operation as necessary to extinguish or control any fire, perform any rescue operation, investigate the

existence of suspected or reported fires, gas leaks or other hazardous conditions or situations, or take any other action necessary in the reasonable performance of duty. In the exercise of such power, the Fire Marshal, or fire chief is authorized to prohibit any person, vehicle, vessel or thing from approaching the scene and is authorized to remove, or cause to be removed or kept away from the scene, any vehicle, vessel or thing which could impede or interfere with the operations of the fire department and, in the judgment of the Fire Marshal, fire chief or his designee, any person not actually and usefully employed in the extinguishing of such fire or in the preservation of property in the vicinity thereof.

104.11.1 Barricades. The Fire Marshal, fire chief or officer of the fire department in charge at the scene of an emergency is authorized to place ropes, guards, barricades or other obstructions across any street, alley, place or private property in the vicinity of such operation so as to prevent accidents or interference with the lawful efforts of the fire department to manage and control the situation and to handle fire apparatus.

104.11.2 Obstructing operations. No person shall obstruct the operations of the fire department in connection with extinguishment or control of any fire, or actions relative to other emergencies, or disobey any lawful command of the Fire Marshal, fire chief or officer of the fire department in charge of the emergency, or any part thereof, or any lawful order of a police officer assisting the fire department.

104.11.3 Systems and devices. No person shall render a system or device inoperative during an emergency unless by direction of the Fire Marshal, fire chief or fire department official in charge of the incident.

104.11.4 Removal of debris and rubble after fire:

(a) The owner or person having under his control or in his possession upon any premises in the county, any hay, straw, bales of wool, cotton, paper or other substances which have been rendered useless or unmerchantable by reason of any fire on such premises, or any debris resulting from such fire, must remove such substances and debris from such premises within forty-eight hours (48) after notice to do so has been served by the Fire Marshal.

(b). Whenever any building or other structure in the county is partially burned, the owner thereof or the person in charge or control thereof, shall within ten days after notice from the Fire Marshal so to do,

remove all refuse, debris, charred and partially burned lumber and material from the ground; and if such building or other structure shall be burned to such an extent that it is rendered incapable of being repaired, the owner of the property upon which structure is located, or person in charge and control thereof, shall within ten days after notice from the Fire Marshal so to do, remove all remaining portion of the building or structure, from the ground.

(c). The Fire Marshal may extend the ten (10) day period of removal of such burned or partially burned buildings, when the insurance adjustment, if any, is still pending.

SECTION 105 - PERMITS

105.2 Application. Application for a permit required by this code shall be made to the fire code official in such form and detail as prescribed by the fire code official. Applications for permits shall be accompanied by such plans as prescribed by the fire code official.

105.2.4 Action on application. The fire code official shall examine or cause to be examined applications for permits and amendments thereto within a reasonable time after filing as defined in applicable state laws. If the application or the construction documents do not conform to the requirements of pertinent laws, the fire code official shall reject such application in writing, stating the reasons therefore. If the fire code official is satisfied that the proposed work or operation conforms to the requirements of this code and laws and ordinances applicable thereto, the fire code official shall issue a permit therefore as soon as practicable.

105.2.5 Working Without a Permit. Work requiring a permit shall not commence until said permit is posted in a conspicuous place on the job site and approved plans are available at this location. Where work is commenced prior to obtaining said permit, the fees may be increased by 100% as determined by the AHJ, but payment of the increased fee shall not relieve any person from fully complying with the requirements to obtain a permit, nor of any other penalties herein.

105.4 Construction documents. Construction documents shall be in accordance with this section.

105.4.2 Information on construction documents.

Construction documents shall be drawn to scale upon suitable material. Electronic media documents are allowed to be submitted when approved by the fire code official. Construction documents shall be of sufficient clarity to indicate the location, nature and extent of the work proposed and show in detail that it will conform to the provisions of this code and relevant laws, ordinances, rules and regulations as determined by the fire code official.

105.4.2.2 Occupancy Classification

Letter. Two (2) copies of a completed "Occupancy Classification Letter" or other approved Fire Protection report shall be submitted to the County for buildings or portions thereof that are to be used for any of the following purposes:

- (a) Warehousing or storage
- (b) Retail including rack display of products
- (c) Hazardous Materials storage and/or use
- (d) Manufacturing
- (e) Sales of upholstered furniture

The Occupancy Classification letter is required to be submitted (1) with the building permit submittal documents when seeking a building permit, (2) to the Fire Inspector during a Certificate of Compliance inspection, or (3) at any other time when required by the Fire Marshal. The Occupancy Classification Letter is to be prepared by the owner and/or tenant of the building/space in question. It is to be signed, dated and on company letterhead. If the Occupancy Classification letter is prepared by a registered design professional, it is to be countersigned by the owner and/or tenant. Prior to a change in (1) the type or amount of hazardous material(s) used or stored, (2) the type or amount of storage or storage height, or method of storage, or (3) the manufacturing process, a revised Occupancy Classification letter is to be submitted to the Fire Marshal's Office for review/approval.

105.4.7 Permit/Plans not on site. When a permit or approved plans are not available upon request by the Fire Marshal, the person in charge of the authorized work shall be assessed a seventy-five dollar (\$75.00) fee, and any further inspections shall not be scheduled or performed until the fee has been paid.

SECTION 106 - INSPECTIONS

106.5 Compliance with Orders and Notices. Orders and notices issued or served as provided by this code shall be complied with by the owner, operator, occupant or other person responsible for the condition or violation to which the order or notice pertains. In cases of extreme danger to persons or property, immediate compliance is required. If the building or other premises is not owner occupied, under lease, or otherwise, and the order or notice requires additions or changes in the building or premises which would immediately become real estate and be the property of the owner of the building or premises, such orders or notices shall be complied with by the owner.

EXCEPTION: When the owner and the occupant have agreed otherwise between themselves, in which event the occupant shall comply.

SECTION 108 - BOARD OF APPEALS

108.1 Board of appeals established. In order to hear and decide appeals of orders, decisions or determinations made by the fire code official relative to the application and interpretation of this code, there shall be and is hereby created a board of appeals consisting of 5 persons residing in Bexar County, who are not employees of the jurisdiction. The board should consist of one (1) structural engineer, one (1) architect, one (1) builder, one (1) member of the public, and one (1) person certified by the International Code Council as a Building Plans Examiner, Commercial Building Inspector, or Residential Building Inspector. The board of appeals shall be appointed by the governing body and shall hold office at its pleasure. The term of office shall not exceed two (2) years and shall be limited to three (3) consecutive two-year terms. All vacancies shall be filled for the unexpired portion of the term only. The fire code official or his designee shall be an ex officio member of said board but shall have no vote on any matter before the board. The board shall adopt rules of procedure for conducting its business, and shall render all decisions and findings in writing to the appellant with a duplicate copy to the fire code official.

SECTION 109 - VIOLATIONS

109.1 Unlawful acts. It shall be unlawful for a person, firm or corporation to erect, construct, alter, repair, remove, demolish or utilize a building, occupancy, premises or system regulated by this code, or cause same to be done, in conflict with or in violation of any of the provisions of this code. No work shall be started on any Fire Protection System at a new

construction site or an existing structure, other than maintenance work, without a permit being issued or by approval to begin work by the Fire Marshal or his designee. Both the individual contractor, along with the site general contractor will be held liable for such actions. Where work is commenced prior to obtaining said permit, the permit fees shall be doubled, but payment of the increased fee shall not relieve any person from fully complying with the requirements to obtain a permit, nor of any other penalties herein.

109.2 Notice of violation or citation. When the fire code official finds a building, premises, vehicle, storage facility or outdoor area that is in violation of this code, the fire code official is authorized to prepare a written notice of violation or citation (as applicable under state law) describing the conditions deemed unsafe and, when compliance is not immediate, specifying a time for reinspection or appearance in court.

109.3 Violation penalties. Persons who shall violate a provision of this code or shall fail to comply with any of the requirements thereof or who shall erect, install, alter, repair or do work in violation of the approved construction documents or directive of the fire code official, or of a permit or certificate used under provisions of this code, shall be guilty of a misdemeanor punishable by a fine of not more than five hundred (500) dollars ~~or by imprisonment not exceeding [NUMBER OF DAYS], or both such fine and imprisonment.~~ Each day that a violation continues after due notice has been served shall be deemed a separate offense.

109.3.2 Offense Penalties. Penalties for citations issued by the Fire Marshal or his designee shall be as listed below, plus court costs.

<u>Code</u>	<u>Section</u>	<u>Offense</u>	<u>Fine</u>
Fire	105.3.3	Occupancy prohibited - (occupancy before issuance of certificate of occupancy)	\$500.00
Fire Building	109.1 109.4	Unlawful Acts Working without permit (plus double permit fee)	\$250.00
Fire	109.2.2	Failure to comply with orders and notices	\$100.00 to \$500.00
Fire	109.2.4	Unauthorized tampering or removal - (tag, seal, sign, or posting)	\$250.00
Fire	110.2.1	Unsafe building-overcrowding	\$500.00
Fire	503.4	Obstructing a Fire Lane	\$500.00
Fire	1030.3	Obstructing Means of Egress	\$500.00
Fire/Building	All others	All other violations	\$100.00 to \$500.00

SECTION 110 - UNSAFE BUILDINGS

110.2 Evacuation. The fire code official or the fire department official in charge of an incident shall be authorized to order the immediate evacuation of any occupied building deemed unsafe when such building has hazardous conditions that present imminent danger to building occupants. Persons so notified shall immediately leave the structure or premises and shall not enter or re-enter until authorized to do so by the fire code official or the fire department official in charge of the incident.

110.2.1. Removal of Occupants. A member of the Fire Marshal's Office is authorized to require the removal of occupants at a location when actual occupancy exceeds the permitted or posted occupant load. A person commits an offense if he refuses to obey an order to vacate.

SECTION 111 - STOP WORK ORDER

111.4 Failure to comply. Any person who shall continue any work after having been served with a stop work order, except such work as that person is directed to perform to remove a violation or unsafe condition, shall be liable to a fine of not less than 100 dollars or more than 500 dollars.

CHAPTER 2 - DEFINITIONS

SECTION 202 - GENERAL DEFINITIONS

shall include the following definitions:

AUTHORIZED EMERGENCY VEHICLE shall have the meaning as defined in the Texas Occupations Code §2308.251.

COMMERCIAL ESTABLISHMENT means a place where goods and commodities or services are provided, displayed, exchanged, sold or bought.

FIRE LANE shall mean any area appurtenant to entrances or exits of a building deemed necessary by the Fire Marshal or his designee to remain free and clear of parked vehicles for access to such building in case of fire or other emergency and designated by him as such, and may include sidewalks, driveways, portions of parking lots, or any other area adjacent to or near building entrances or exits, or any fire hydrant. Fire lanes identified or designated by the Fire Marshal or his

designee shall be conspicuously marked and identified as set out in the Texas Occupations Code §2308.251(c).

PUBLIC BUILDING; PUBLIC ACCESS BUILDING; PUBLIC ACCESSIBLE BUILDING means a place in which the possession and/or use, as well as the property in it, gives members of the public free access or use and includes buildings in which the public may enter, including where an entry fee is charged; or otherwise comply with the requirements of an "Occupiable Space" as defined in the 2009 International Building Code.

MULTI-FAMILY DWELLING means any residential structure consisting of four (4) or more residential dwelling units. (Dwelling Unit - A single unit providing complete, independent living facilities for one or more persons, including permanent provisions for living, sleeping, eating, cooking and sanitation.) These buildings are typically, but not always, classified within the Group "R" occupancy classification.

OCCUPANT means any person, agent, firm, or corporation that occupies a building or part thereof as an owner or tenant.

CHAPTER 3 - GENERAL PRECAUTIONS AGAINST FIRE

SECTION 308 - OPEN FLAMES

308.1.2.1 Projection of Ignited Materials. No person shall drop or throw ignited materials from a structure or vehicle.

308.1.4.1 Fire Hazard Prohibited. In Group R, Division 1, 2 & 4 occupancies, a person shall not construct, erect, install, maintain or use any incinerator or barbeque pit or grill or so burn any combustible material as to constitute or occasion a fire hazard by the use or burning thereof or as to endanger the life or property of any person thereof. The use or burning of any such devices under the following conditions shall constitute a fire hazard and are prohibited: (1) within ten (10) linear feet of any combustible surface, including but not limited to decks, porches, balconies, walls, or verandas; (2) beneath any balcony, porch, roof overhang, deck, or veranda.

SECTION 311 - VACANT PREMISES

311.1 General. Temporarily unoccupied buildings, structures, premises or portions thereof, including tenant spaces, shall be safeguarded and maintained in accordance with this section.

311.1.1 Abandoned premises. Buildings, structures and premises for which an owner cannot be identified or located by dispatch of a certificate of mailing to the last known or registered address, which persistently or repeatedly become unprotected or unsecured, which have been occupied by unauthorized persons or for illegal purposes, or which present a danger of structural collapse or fire spread to adjacent properties shall be considered abandoned, declared unsafe and abated by demolition or rehabilitation in accordance with the ~~International Property Maintenance Code~~ and the ~~International Building Code~~ Texas Health and Safety Code, Title 5, Chapter 343 and/or Texas Local Government Code, Title 11, Chapter 352.

SECTION 315 - MISCELLANEOUS COMBUSTIBLE MATERIALS STORAGE

315.2 Storage in buildings. Storage of combustible materials in buildings shall be orderly. Storage shall be separated from heaters or heating devices by distance or shielding so that ignition cannot occur.

315.2.2 Means of egress. Combustible materials shall not be temporarily or permanently stored in exits or exit enclosures.

315.2.3 Equipment rooms. Combustible material shall not be stored in boiler rooms, mechanical rooms or electrical equipment rooms; nor within ten (10) feet of any boiler room, mechanical room or electrical room door.

CHAPTER 4 - EMERGENCY PLANNING AND PREPAREDNESS

SECTION 403 - PUBLIC ASSEMBLAGES AND EVENTS

403.1 Fire watch personnel. When, in the opinion of the fire code official, it is essential for public safety in a place of assembly or any other place where people congregate, because of the number of persons, or the nature of the performance, exhibition, display, contest or activity, the owner,

agent, or lessee or other person in responsible control of the building shall provide one or more fire watch personnel, as required and approved, to remain on duty during the times such places are open to the public, or when such activity is being conducted.

403.1.1 Duties. Fire watch personnel shall keep diligent watch for fires, obstructions to means of egress and other hazards during the time such place is open to the public or such activity is being conducted and take prompt measures for remediation of hazards, extinguishment of fires that occur and assist in the evacuation of the public from the structures. In the event of an emergency, after evacuation of the facility, the fire watch shall take appropriate actions to secure the facility until the arrival of an appropriate emergency response agency having the capabilities to manage the incident.

403.1.2 County owned properties. The Bexar County Fire Marshal shall be responsible to provide a fire watch as defined in 403.1 on all county owned property, including county owned buildings, where the number of occupants will be in excess of 1,000.

403.1.3 Where required. Where required, fire watches shall be provided with at least one approved means for notification of the fire department and their only duty shall be to watch for fires, obstructions to means of egress and other hazards. The cost of the fire watch shall be at the current rate established by the Fire Marshal's Office and shall be the sole responsibility of the owner/contractor to pay. The fire watch fee shall be paid directly to the individual performing the fire watch work when the performance, exhibition, display, contest or activity has been completed. The established rate is as follows:

Fire Dispatcher (if required)	\$30.00 per hour or fraction thereof
Fire Inspector, Fire Investigator or Firefighter	\$35.00 per hour or fraction thereof
Supervisor or Fire Department Officer	\$40.00 per hour or fraction thereof
Fire Marshal Administrator or Chief Officer of Fire Department	\$50.00 per hour or fraction thereof

403.1.4 Fire Watch Personnel. Personnel assigned to fire watch duties must be certified by the Texas Commission on Fire Protection as a Fire Inspector; must perform all fire watch duties while off duty, and

must have approval of the Fire Marshal's Office to perform the specific fire watch.

SECTION 404 - FIRE SAFETY AND EVACUATION PLANS

404.2 Where required. An approved fire safety and evacuation plan shall be prepared and maintained for the following occupancies and buildings.

1. Group A, other than Group A occupancies used exclusively for purposes of religious worship that have an *occupant load* less than 2,000. Places of Assembly shall have written emergency evacuation plans approved by the Fire Marshal or his designee.
2. Group B buildings having an *occupant load* of 500 or more *persons* or more than 100 *persons* above or below the lowest *level of exit discharge*.
3. Group E.
4. Group F buildings having an *occupant load* of 500 or more *persons* or more than 100 *persons* above or below the lowest *level of exit discharge*.
5. Group H.
6. Group I.
7. Group R-1.
8. Group R-2 college and university buildings.
9. Group R-4.
10. High-rise buildings.
11. Group M buildings having an *occupant load* of 500 or more *persons* or more than 100 *persons* above or below the lowest *level of exit discharge*.
12. Covered malls exceeding 50,000 square feet (4645 m²) in aggregate floor area.
13. Underground buildings.
14. Buildings with an atrium and having an occupancy in Group A, E or M.

SECTION 405 - EMERGENCY EVACUATION DRILLS

405.4.1 Fire Marshal's Power to Order Fire Drill. The Fire Marshal may require a fire drill at any reasonable time, depending on the time of day the building is normally occupied.

SECTION 408 - USE AND OCCUPANCY-RELATED REQUIREMENTS

408.2 Group A Occupancies. Group A occupancies shall comply with the requirements of Sections 408.2.1 and 408.2.2 through 408.2.5 and Sections 401 through 406.

408.2.3 Exhibit Halls. The operator of a premise used as a place of exhibition shall:

1. Notify each lessee of the Fire Code requirements at the time the lease is made;
2. Where required by the Fire Marshal, submit to the Fire Marshal's Office, fifteen (15) days before public operation, a detailed explanation of the nature of the operation and two (2) copies of accurately scaled floor plans which show:
 - a. The exhibit layout;
 - b. Aisles;
 - c. Exits;
 - d. Exhibits;
 - e. Show decorator's booth
 - f. Location and nature of fire extinguishers/extinguishing equipment;
 - g. Dates when open to the public or trade; and
3. Construct, operate, and maintain the exhibition in a manner satisfying this code and the approved plans.
4. Shall employ one (1) or more certified fire inspector(s) as required and approved by the Fire Marshal, to be on duty at such place whenever, in the opinion of the Fire Marshal, it is essential for public safety.

408.2.4 Sitting or Standing in Aisles Prohibited.

The operators of premises used as a place of assembly shall prevent the sitting or standing in aisles, passageways, exit pathways, or stairways, while the premises are occupied.

408.2.4.1 Obstructing Required Means of

Egress. The owner, operator or occupant of premises used as a place of assembly shall prevent the placement of any item that obstructs any portion of the required width of the Means of Egress System to include:

- a. Common path of travel;
- b. Exit access;
- c. Exit, to include locking, blocking, chaining, or otherwise render the exit inoperable; or
- d. Exit discharge

408.2.5 Automotive Vehicles: Equipment in

Exhibit Halls. The operator of, and exhibitors at premises used as a place of exhibition may display

automotive vehicles and equipment inside a structure if:

1. The amount of fuel in the vehicle or equipment fuel tanks is limited to the greater of:
 - a. The minimum amount required for vehicle positioning; or
 - b. One quarter tank;
 - c. Five (5) gallons, whichever is less.
2. Vehicle or equipment tanks are effectively locked and adequately sealed;
3. Vehicle or equipment battery cables are disconnected from the ignition system;
4. Vehicle or equipment ignition keys are possessed at all times by a responsible person at the display location;
5. Vehicle operation is limited to brief parade style displays as specifically approved by the Fire Marshal;
6. Show vehicles with LPG tanks shall not be permitted inside the exhibit halls.

CHAPTER 5 - FIRE SERVICE FEATURES

SECTION 501 - GENERAL

501.3 Construction documents. Construction documents for proposed fire apparatus access, location of fire lanes, security gates across fire apparatus access and construction documents and hydraulic calculations for fire hydrant systems shall be submitted to the ~~fire department~~ Fire Marshal's Office for review and approval prior to construction.

501.3.1 Site Plan. Two copies of the Fire Protection Site Plan (labeled as such) shall be submitted with the construction documents when application is made for a building permit. The Fire Protection Site Plan shall be drawn to scale (no less than 1:60) and shall show and include, but not be limited to, the following:

1. Compass Reading
2. Property and/or Lot Lines
3. Street Frontage
4. Location of all buildings (existing and proposed)
5. Fire apparatus access roads (i.e., fire lanes) to buildings. Fire lanes shall be highlighted and shall include dimensions (width, turning radii, clearance to overhead obstructions, etc.)
6. Fences, gates, wall, streams, and other obstructions to firefighter access.
7. Location of all fire hydrants (existing and proposed). This shall include the direction and distance to all hydrants not shown on the site

- plan, but within one thousand (1000) feet of the building to be protected.
8. Size (diameter and length) and location of all fire main piping (proposed and existing). The pressure class and type of new pipe installed shall be identified.
 9. The location, type, and size of backflow prevention device(s), where installed.
 10. Location of all automatic sprinkler and standpipe risers.
 11. Location of Fire Department connection(s).
 12. Size, type, and location of valves including post indicator valve (if they are located in a pit), control room(s), automatic sprinkler system shut-off, etc.
 13. Other water supplies
 14. Type of protection from collision that may cause physical damage to fire protection equipment.

- 6) If sand or other free-flowing fill is used as a main structural component for the surface, concrete curbing, or other approved edging, shall be installed along both sides of the surface for material containment. A registered design professional shall design such curbing. Sealed drawings of the design said curbing. Sealed drawings of the design shall be provided to the Fire Marshal's Office for review.
- 7) A signed letter from the manufacturer shall be provided to the Fire Marshal's Office certifying that the installation meets all requirements in the manufacturer's installations prior to issuance of the Certificate of Occupancy.
- 8) The surface shall be maintained in proper working order at all times when utilized as a required fire lane. Should the surface become damaged or fall into disrepair, the Fire Marshal or his designee shall be authorized to require the repair and re-certification of said surface.

SECTION 503 - FIRE APPARATUS ACCESS ROADS

503.2 Specifications. Fire apparatus access roads shall be installed and arranged in accordance with Sections 503.2.1 through 503.2.8.

503.2.3 Surface. Drivable grass surfaces are permitted when approved by the Fire Marshal or his designee and in accordance with all of the following:

- 1) The drivable grass surface shall not be used as the primary access to the site.
- 2) The surface shall be capable of supporting the imposed load of fire apparatus weighing at least 75,000 pounds.
- 3) Blue traffic reflectors shall be provided on each side of the surface every 20 feet to clearly mark its boundaries. Vegetation on and surrounding the surface shall be maintained such that said reflectors are visible at all times.
- 4) Sod is not permitted to be placed over the drivable base.
- 5) If the surface proposed is to be used as the aerial apparatus access road for the facility, concrete curbing, or other approved edging, shall be installed along both sides of the portion to be used as such for enhanced lateral stability. A registered design professional shall design said curbing. Sealed drawings of the design shall be provided to the Fire Marshal's Office for review.

503.2.4 Turning radius. The required turning radius of a fire apparatus access road shall be determined by the fire code official. See Appendix D for minimum design requirements.

503.2.5 Dead ends. Dead-end fire apparatus access roads in excess of 150 feet (45 720 mm) in length shall be provided with an approved area for turning around fire apparatus. See Appendix D for minimum design requirements.

503.2.7 Grade. The grade of the fire apparatus access road shall be within the limits established by the fire code official based on the fire department's apparatus.

503.2.7.1 Grade Increases. The gradient for fire apparatus access roads may be increased when the following conditions are met:

- 1) All grades in excess of 10%, but not in excess of 12.0%, may be approved when all of the following conditions exist:
 - a) The length of the grade does not exceed 300 feet from the beginning point of the grade to

- the termination point of the grade,
- b) The termination point of the grade is not within 150 feet of a down-hill intersection, cul-de-sac, or hammerhead,
 - c) The last 75 feet of a down-hill slope approaching an intersection is not greater than 5%,
 - d) A grade indicating sign, showing the international symbol for a grade, as well as the numerical percentage of the grade, is installed within 75 feet of the start of both the up-hill and down-hill portions of the grade.
- 2) All grades in excess of 12.0% may be approved when **all** of the following conditions exist:
- a) The termination point of the grade is not within 150 feet of a down-hill intersection, cul-de-sac, or hammerhead,
 - b) The last 75 feet of a down-hill slope approaching an intersection is not greater than 5%,
 - c) A grade indicating sign, showing the international symbol for a grade, as well as the numerical percentage of the grade, is installed within 75 feet of the start of both the up-hill and down-hill portions of the grade.
 - d) All structures on a fire department access road with a grade greater than 12.0% are provided with a public water supply sufficient to meet the fire flow requirements of Table

B105.1 and hydrant distribution to meet the requirement of Table C105.1.

- e) **ALL** structures regulated by the International Building Code with access off a fire department access road with a grade greater than 12.0% **MUST** be provided with a fire sprinkler system in accordance with Section 903.3.

503.2.8 Angles of approach and departure. The angles of approach and departure for fire apparatus access roads shall be within the limits established by the fire code official based on the fire department's apparatus. The maximum angle of approach and departure shall not exceed 8%.

503.3 Marking (Fire Lanes). Where required by the fire code official, approved signs or other approved notices or markings that include the words **NO PARKING – FIRE LANE – TOW AWAY ZONE** shall be provided for fire apparatus access roads (fire lanes) to identify such roads or prohibit the obstruction thereof. The means by which fire lanes are designated shall be maintained in a clean and legible condition at all times and be replaced or repaired when necessary to provide adequate visibility.

503.3.1 Sign Design and Painted Markings. When required to be posted, all signs, curb painting and marking, and parking lot fire lane markings shall conform to the requirements for lettering and wording as defined in the Texas Occupations Code §2308.251(c).

TEXAS OCCUPATIONS CODE

§ 2308.251. PROHIBITION AGAINST UNATTENDED VEHICLES IN CERTAIN AREAS. (a) The owner or operator of a vehicle may not leave unattended on a parking facility a vehicle that:

- (1) is in or obstructs a vehicular traffic aisle, entry, or exit of the parking facility;
- (2) prevents a vehicle from exiting a parking space in the facility;
- (3) is in or obstructs a fire lane marked according to Subsection (c); or
- (4) does not display the special license plates issued under Section 504.201 or the disabled parking placard issued under Chapter 681 for a vehicle transporting a disabled person and is in a parking space that is designated for the exclusive use of a vehicle transporting a disabled person.

(b) Subsection (a) does not apply to an emergency vehicle that is owned by, or the operation of which is authorized by, a governmental entity.

(c) If a government regulation governing the marking of a fire lane applies to a parking facility, a fire lane in the facility must be marked as provided by the regulation. If a government regulation on the marking of a fire lane does not apply to the parking facility, all curbs of fire lanes must be painted red and be conspicuously and legibly marked with the warning "FIRE LANE--TOW AWAY ZONE" in white letters at least three inches tall, at intervals not exceeding 50 feet.

Acts 1995, 74th Leg., ch. 165, § 1, eff. Sept. 1, 1995. Amended by Acts 2005, 79th Leg., ch. 728, § 20.003(j), eff. Sept. 1, 2005. Renumbered from Transportation Code, Section 684.011 and amended by Acts 2007, 80th Leg., R.S., ch. 1046, Sec. 2.03, eff. Sept. 1, 2007

Fire Lane Sign Design Requirements for 2003 International Fire Code, Figure D103.6 to Comply with Texas Occupations Code

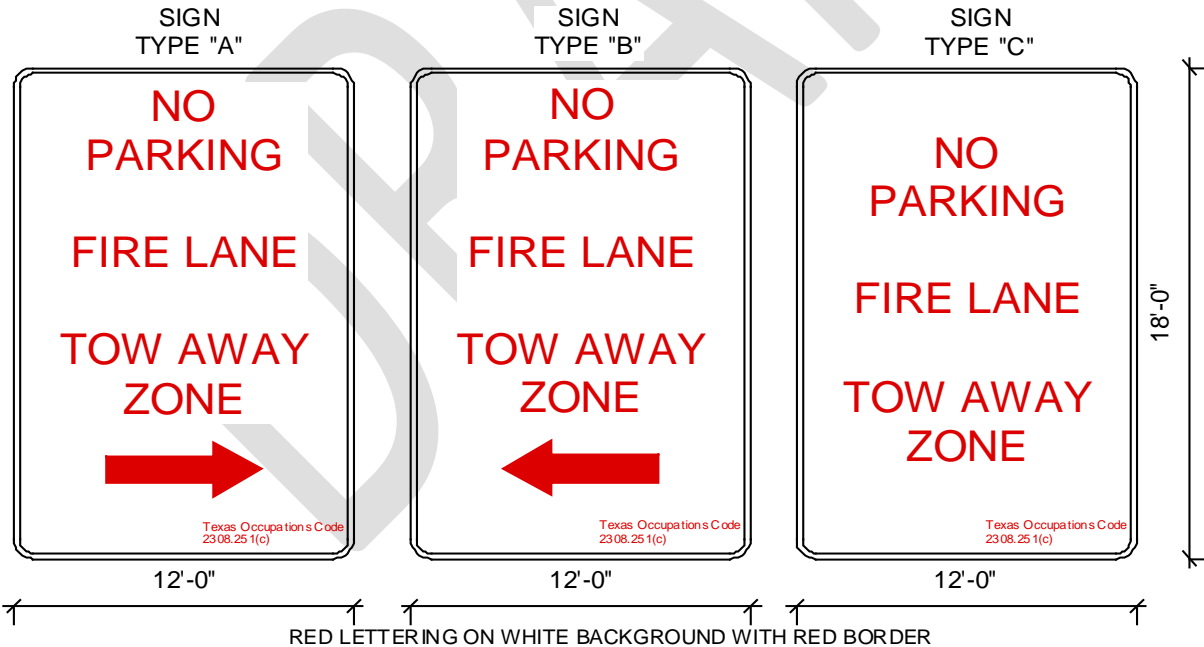

503.6 Security gates. The installation of security gates across a fire apparatus access road shall be approved by the ~~fire chief~~ Fire Marshal or his designee. Where security gates are installed, they shall have an approved means of emergency operation. The security gates and the emergency operation shall be maintained operational at all times.

503.6.1 Key Box at Security Gate Entrance. A key box, meeting the requirements of the Fire Marshal's Office shall be provided at the entrance side of manual operated security gates. The KNOX padlock or key box and/or operating mechanism(s), shall be accessible to Bexar County emergency response agencies as well as to the fire department serving the area in which the box is located.

503.6.2 Siren-Operated Sensor System. A siren-operated sensor system shall be installed at all electrically operated gates. The S.O.S. system shall operate all electrically operated gates upon the activation of the siren of an emergency response vehicle.

503.7 Summons to be Issued for Parking Violation. In unincorporated areas of Bexar County, a citation (summons) to answer to a charge of parking in a designated fire lane, specifying the location of the fire lane in which the violation occurred, and the date and time of such violation, may be issued by any sheriff's deputy, constable, or an Inspector or Investigator of the Fire Marshal's Office.

503.8 Removal of Vehicle by Property Owner. The owner, or the agent of the owner, may have any motor vehicle that is parked in a required fire lane, except an authorized emergency vehicle, removed and stored at the expense of the vehicle owner or operator.

503.9 Removal of Vehicle by Sheriff, Constable, or Fire Marshal. Any vehicle parked in any designated fire lane may be removed at the vehicle owner's or operator's expense on authorization of the Sheriff's Deputy, Constable, or Fire Marshal under the following conditions:

1. When the vehicle violates the fire lane regulations indicated in Section 503.4 by parking in a fire lane, or
2. When a vehicle blocks the ingress/egress of a business, theater, night club, apartment complex, or a place of assembly, or
3. When a vehicle's presence threatens the life safety of the public by impeding the ability of an authorized emergency vehicle to respond to an emergency.

503.10 Abandonment of Fire Lane. No owner, manager or person in charge of any premises served by a required fire lane shall abandon, close, or otherwise prevent the use of such fire lane without the written permission of the Fire Marshal or his designee.

SECTION 505 - PREMISES IDENTIFICATION

505.1 Address numbers. New and existing buildings shall have approved address numbers, building numbers or approved building identification placed in a position that is plainly legible and visible from the street or road fronting the property. These numbers shall contrast with their background. Address numbers shall be Arabic numerals or alphabet letters. Numbers shall be a minimum ~~of 4~~ of 6 inches (102 mm) high with a minimum stroke width of 0.5 inch (12.7 mm). Where access is by means of a private road and the building cannot be viewed from the public way, a monument, pole or other sign or means shall be used to identify the structure.

505.1.1 Multiple Buildings. Where there are multiple buildings at a single property address, each building shall have building number(s) meeting the requirements of 505.1 posted on the building in a location that is plainly legible and visible from the driving surface closest to the building.

SECTION 506 - KEY BOXES

506.1 Where required. Where access to or within a structure or an area is restricted because of secured openings or where immediate access is necessary for life-saving or fire-fighting purposes, the fire code official is authorized to require a KNOX key box to be installed in an approved location. The KNOX key box shall be of an approved type and shall contain keys to gain necessary access as required by the fire code official.

506.1.1 Locks. An approved KNOX lock shall be installed on gates or similar barriers when required by the fire code official.

506.2 Key box maintenance. The operator of the building shall immediately notify the fire code official and provide the new key when a lock is changed or rekeyed. The key to such lock shall be secured in the KNOX key box.

506.3 Key Box Location. Required KNOX key boxes shall be located within eight (8) to ten (10) feet to the side of the main entrance to the building and between eight (8) to ten (10) feet above the entrance door grade level. The KNOX key box shall contain, but not be limited to, (1) elevator keys capable of accessing all floor levels, (2) stairway keys, (3) fire control station keys, (4) fire alarm system keys, and (5) keys to all entrance/exit doors.

SECTION 507 - FIRE PROTECTION WATER SUPPLIES

507.3 Fire flow. Fire flow requirements for buildings or portions of buildings and facilities shall be as indicated in the 2009 International Fire Code, Appendix B, or as determined by an approved method.

507.3.1 Fire Flow for Rural and Isolated Areas. For rural, isolated structures in areas where there is no developed fire protection water supply system, the Fire Marshal or his designee may modify the minimum fire flow requirements indicated in 508.3 under the following conditions:

- a. When a building is required to have an automatic fire sprinkler system – an on-site water storage tank is provided with a quantity of water sufficient to provide a minimum of 20 minutes of fire sprinkler coverage for the largest designed remote area; or,
- b. When a building is not required to have an automatic fire sprinkler system – an on-site fire hydrant and water storage tank is provided with a quantity of water sufficient to provide the responding fire department a minimum of 20 minutes of firefighting water supply at a rate of 1,500 gpm; and/or,
- c. An automatic fire alarm system is installed throughout the structure; and/or
- d. The required Fire Resistance construction rating is increased by one level (i.e., non-rated is increased to one-hour, one-hour is increased to two hour, etc.); and
- e. The Means of Egress System corridors and exits are increased by a design factor of 1.5.
- f. A minimum of a 60 foot yard is provided on all sides and between other buildings and property lines.

507.5 Fire hydrant systems. Fire hydrant systems shall comply with Sections 507.5.1 through 507.5.6.

507.5.1 Where required. Where a portion of the facility or building hereafter constructed or moved into or within the jurisdiction unincorporated Bexar County is more than 400 feet (122 m) from a hydrant on a fire apparatus access road, as measured by an approved route around the exterior of the facility or building, on-site fire hydrants and mains shall be provided where required by the fire code official.

Exceptions:

1. For Group R-3 and Group U occupancies, the distance requirement shall be 600 feet (183 m).
2. For buildings equipped throughout with an approved automatic sprinkler system installed in accordance with Section 903.3.1.1 or 903.3.1.2, the distance requirement shall be 600 feet (183 m).

507.5.1.1 Residential Subdivision Fire Protection Required. Where a residential subdivision or development is constructed in unincorporated Bexar County, the subdivision developer shall provide and maintain a fire protection distribution system with fire hydrant spacing not exceeding 600 feet.

507.5.1.2 Fire Hydrant Installation Criteria. Fire hydrants shall be installed per the following criteria:

- 1) Fire hydrants shall be a minimum of two (2) feet and a maximum of seven (7) feet from the gutter face of the curb.
- 2) The steamer connection (large opening) shall face the public street and shall be a minimum of one and one-half (1.5) feet and a maximum of two (2) feet above grade.
- 3) Fire hydrants shall be painted red
- 4) Fire hydrants shall be right turn only
- 5) An unobstructed radius of three (3) feet shall be maintained around the fire hydrant.

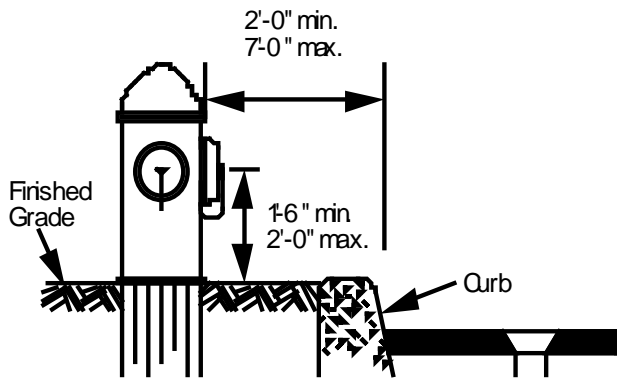

**SECTION 510 – CITY OF SAN ANTONIO/BEXAR
COUNTY EMERGENCY RESPONDER RADIO
COVERAGE**

Section 510.1 Radio Coverage. Except as otherwise provided, no person shall erect, construct, or modify any building or structure or any part thereof, or cause the same to be done which fails to support adequate radio coverage for Bexar County/City of San Antonio public safety services, including but not limited to police, fire, and public works departments. A Certificate of Compliance may not be issued for any building or structure which fails to comply with this requirement.

The frequency range which must be supported shall be 800 MHz range, or as otherwise established and required in writing by Bexar County as being necessary for public safety purposes.

For the purposes of this code, adequate radio coverage shall include the following:

- (1) A minimum signal level of DAQ 3 (Delivered Audio Quality #) available in 95% of the area as agreed to be in the coverage acceptable test plan by Bexar County and the radio system manufacturer prior to system testing.

Section 510.2 Amplification System allowed. Buildings and structures shall be equipped with any of the following, in order to achieve adequate radio coverage:

- (1) A radiating cable system; or
- (2) An internal multiple system with FCC Type Accepted Bi-Directional UHF Amplifiers as needed to encompass the frequency range stated above or frequency range subsequently established by the city.
- (3) A system that has been approved by the City of San Antonio as being capable of providing amplification to meet this code requirement.

The system shall be capable of operating on an independent battery and/or generator system for a period of at least 12 hours without external power input. The battery system shall automatically charge in the presence of external power input. There shall be no connectivity between the amplification system and fire alarm system.

507.5.1.3 Fire Hydrant Location and Spacing. Fire hydrants shall be located and spaced per the following criteria:

- 1) Hose lay is measured along public streets, fire lanes, and access roadways for Fire Department vehicles. This hose lay consists of three hundred fifty feet (350) of supply line as deployed by truck, and one hundred fifty (150) feet of hose deployed by hand. Unless otherwise increased in this code, where the building is equipped throughout with an approved sprinkler system installed in accordance with Section 903.3.1.1, 903.3.1.2, or 903.3.1.3, the maximum distance from hydrants to a point on the building shall be increased to 700 feet as the hose lays with 500 foot hose lay by the truck and 200 foot hose lay by hand.
- 2) No fire flow credit is allowed for hydrants which are so obstructed as to make their use impractical, such as hydrants across main line railroad tracks that are in heavy use or across limited access highway, expressways, primary thoroughfares, across streams, walls, etc.
- 3) Hydrant spacing along both public and private water mains shall not be closer than 300 feet and shall not exceed six hundred (600) feet.
- 4) Fire hydrants shall be located along the public right-of-way or along the Fire Department access roadways, preferably at intersections or on islands separating parking areas, which cannot be obstructed by parked vehicles. Hydrants in areas subject to physical damage shall be protected from collision. Fire hydrants across more than four (4) lanes of traffic (including turning lanes) or across medians are not considered accessible.

Section 510.3 Owner Responsibility. It shall be the responsibility of the owner of a building or structure which currently holds a certificate of compliance or allows the building or structure to be used for any purpose other than construction, to be in compliance with this chapter upon its effective date.

Section 510.4 Inadequate Radio Coverage. Any building or structure which fails to support adequate radio coverage must have a plan acceptable to the Bexar County Public Safety Communications Supervisor within 90 days by the owner or his agent to address the inadequate radio coverage.

Section 510.5 Acceptance Test Procedures. Acceptance testing for an in-building radio amplification system is required, upon completion of installation of the system. It is the building owner's responsibility to have the radio system tested to ensure that two-way coverage on each floor of the building is a minimum of DAQ 3.

Each floor of the building shall be divided into a grid of approximately forty equal areas. A maximum of two nonadjacent areas will be allowed to fail the test. In the event that three of the areas fail the test, in order to be more statistically accurate the floor may be divided into eighty equal areas. In such event, a maximum of four nonadjacent areas will be allowed to fail the test. After the eighty area tests, if the system continues to fail the building owner shall repair, replace, alter or upgrade the system altered to meet the DAQ 3 coverage requirement. Talk back testing from site to the Bexar County Public Safety Dispatch Center shall use a two watt portable transceiver with speaker/microphone and flexible antenna. A spot located approximately in the center of a grid area will be selected for the test, then the radio will be keyed to verify two-way communication to and from the outside of the building. Once the spot has been selected, use of another spot within the grid area will not be permitted. Field strength testing instruments are to be recently calibrated (within 12 months) and of the frequency selective type incorporating a flexible antenna similar to the ones used on the hand held transceivers.

The gain values of all amplifiers shall be measured and the results kept on file with the building owner so that the measurements can be verified each year during the annual tests. In the event that the measurement results become lost, the building owner will be required to rerun the acceptance test to reestablish the gain values.

Section 510.6 Annual Tests. When an in-building radio system is installed, the building owner shall test all active components of the system including but not limited to the amplifier, the power supplies, and back-up batteries, a minimum of once every 12 months. Amplifiers shall be tested to ensure that the gain is the same as it was upon initial installation and acceptance. Back-up batteries and power supplies shall be tested under load for a period of one hour to verify that they will operate during an actual power outage. All other active components shall be checked to determine that they are operating within the manufacturers specifications for the intended purpose.

Section 510.7 Five Year Test. In addition to the annual test, the building owner shall perform a radio coverage test a minimum of once every five years to ensure that the radio system continues to meet the requirements of the original acceptance. The procedure set forth above shall apply to such tests.

Section 510.8 Qualifications of testing personnel. All tests shall be conducted, documented, and signed by a person in possession of a current FCC general radiotelephone operator license. All test records shall be retained at the inspected premises by the building owner and a copy submitted to the Bexar County Public Safety Communications Center within 30 days of when the test has been conducted. In the event the test shall fail to comply with the minimum requirements of the county, appropriate repairs shall be made and additional tests conducted until tests meet the minimum requirements of the county.

Section 510.9 Inspections. County personnel, after providing reasonable notice to the owner or his representative, shall have the right to enter onto the property to conduct field testing to be certain that the required level of radio coverage is present.

Section 510.10 Property owner maintenance responsibilities. Upon completion of all the tests to the minimum standards of Bexar County, the property owner shall be responsible for maintenance of the system. A maintenance contract shall be provided to the Bexar County Public Safety Communications Center with the name of the contractor, who will supply a 24-hour, 7-day emergency response within 2 hours after notification by either Bexar County or the property owner. The maintenance contract shall also contain information as to contact personnel with phone numbers. Property owners shall also submit information to the Bexar County Public Safety Communications Center as to contact personnel with phone numbers for the property owner. The property owner shall

also be responsible for making any repairs, replacement or upgrades to the systems as directed by the Bexar County Public Safety Communications Center Supervisor, should the system fail or no longer work in the future.

Section 510.11 Exemptions. This section shall not apply to buildings less than 50,000 square feet or any single-family detached residential dwelling or a multifamily building or structure less than 50,000 square feet or any building under four stories with less than 50,000 square feet per floor.

Section 510.12 Failure to comply. Failure to comply with this code shall be grounds for the Fire Marshal or his designee to revoke any previously issued Certificate of Compliance for the building or structure. A written appeal may be taken to the Appeals Board regarding the revocation of the Certificate of Compliance within 30 days of the revocation.

CHAPTER 6- BUILDING SERVICES AND SYSTEMS

SECTION 609 – COMMERCIAL KITCHEN HOODS

[M] 609.2 Where required. A Type I hood shall be installed at or above all commercial cooking appliances and domestic cooking appliances used for commercial purposes that produce grease vapors.

609.2.1 Commercial Vent/Hood Extinguishing Systems. A commercial fire extinguishing system shall be installed in all Type I hoods at or above all commercial cooking and/or domestic cooking appliances utilized in commercial cooking operations that produce grease laden vapors.

Exception: A residential Vent/Hood extinguishing system is permitted to be utilized when only domestic cooking appliances are utilized in the following:

1. Employee Break Rooms
2. Licensed Care Facilities operating in Group R-3 occupancy

CHAPTER 7- FIRE-RESISTANCE-RATED CONSTRUCTION

SECTION 703 - FIRE-RESISTANCE-RATED CONSTRUCTION

703.1.4 Occupancy separation. In multiple occupancy buildings, where there is an undefined or unknown future occupancy area, all interior occupancy separations walls shall be a minimum of two (2) hour fire barrier walls, completed and finished on both sides.

CHAPTER 8 - INTERIOR FINISH, DECORATIVE MATERIALS AND FURNISHINGS

SECTION 807 - DECORATIVE MATERIALS OTHER THAN DECORATIVE VEGETATION IN NEW AND EXISTING BUILDINGS

807.4.3.2 Artwork. Artwork and teaching materials shall be limited on the walls of corridors to not more than 20 percent of the wall area and the walls of classrooms to not more than 50 percent of the wall area. There shall be no combustible materials hanging from the ceiling.

807.4.4.2 Artwork. Artwork and teaching materials shall be limited on the walls of corridors to not more than 20 percent of the wall area and the walls of classrooms to not more than 50 percent of the wall area. There shall be no combustible materials hanging from the ceiling.

CHAPTER 9 - FIRE PROTECTION SYSTEMS

Special Note – throughout the 2009 International Fire Code, where the code requires a fire protection device to generate a supervisory signal, Bexar County requirements shall require this signal to activate the fire alarm system or send a non-emergency dispatch advisory to a constantly attended, off-site monitoring station.

SECTION 901 - GENERAL

901.7 Systems out of service. Where a required fire protection system is out of service, the fire department and the fire code official shall be notified immediately, but normally at least 48 hours in advance and, where required by the fire code official, the building shall either be evacuated or an approved fire watch shall be provided for all occupants left unprotected by the shutdown until the fire protection system has been returned to service.

Where utilized, fire watches shall be provided with at least one approved means for notification of the fire department and their only duty shall be to perform constant patrols of

the protected premises and keep watch for fires. The cost of the fire watch shall be at the current rate established by the Fire Marshal's Office and shall be the sole responsibility of the owner/contractor to pay. The fire watch fee shall be paid directly to the individual performing the fire watch work when the fire protection system has been fully restored to operation. The established rate is as follows:

Fire Dispatcher (if required)	\$30.00 per hour or fraction thereof
Fire Inspector, Fire Investigator or Firefighter	\$35.00 per hour or fraction thereof
Supervisor or Fire Department Officer	\$40.00 per hour or fraction thereof
Fire Marshal Administrator or Chief Officer of Fire Department	\$50.00 per hour or fraction thereof

SECTION 903 - AUTOMATIC SPRINKLER SYSTEMS

903.3.1.2.2 Attic Protection. In addition to the protection requirements of NFPA 13R, sprinkler protection shall be engineered and provided in all attic spaces of Type V construction.

903.3.1.3.1 Attic Protection. In addition to the protection requirements of NFPA 13D, sprinkler protection shall be engineered and provided in all attic spaces of Type V construction.

903.6 Existing buildings. The provisions of this section are intended to provide a reasonable degree of safety in existing structures not complying with the minimum requirements of the *International Building Code* by requiring installation of an automatic fire-extinguishing system, including the following:

- a) Existing structures that are being substantially improved as defined in the Local Government Code, Title 7, Chapter 233.
- b) Existing structures being remodeled where a modification is being made to the common path of exit travel, exit access, or exit(s) of the building.
- c) Existing structures built prior to the date of the adoption of the 2009 International Fire Code, which did not obtain permits as required by the Local Government Code, Title 7, Chapter 233.

903.7 Separation from Non-Sprinklered Areas. Unless otherwise exempted by the 2009 International Building Code (IBC) or 2009 International Fire Code

(IFC) or required to be of a higher fire resistance construction by the IBC or IFC, a minimum of one (1) hour fire barrier construction in accordance with the 2009 IBC shall be provided between sprinklered and unsprinklered areas within a building.

SECTION 904 – ALTERNATIVE AUTOMATIC FIRE-EXTINGUISHING SYSTEMS

904.11.1 Manual system operation. A manual actuation device shall be located at or near a means of egress from the cooking area a minimum of 10 feet (3048 mm) and a maximum of 20 feet (6096 mm) from the kitchen exhaust system. The manual actuation device shall be installed not more than 48 inches (1200 mm) nor less than 42 inches (1067 mm) above the floor and shall clearly identify the hazard protected. The manual actuation shall require a maximum force of 40 pounds (178 N) and a maximum movement of 14 inches (356 mm) to actuate the fire suppression system.

Exception: Automatic sprinkler systems shall not be required to be equipped with manual actuation means.

904.11.1.1 Manual system operation device color. The manual actuation device for an alternative fire-extinguishing system shall be silver or white in color, and shall not resemble a fire alarm system actuation device. The color of the manual actuation device for an alternative fire-extinguishing system shall apply to both commercial and residential fire-extinguishing systems.

904.11.1.2 Multiple manual system operation devices. Where there is multiple manual actuation devices for a alternative fire-extinguishing system, each actuation device and the corresponding fire extinguishing system shall be provided with an identification plate that indicates which system the device operates.

SECTION 907 - FIRE ALARM AND DETECTION SYSTEMS

907.2.2 Group B. A manual fire alarm system shall be installed in Group B occupancies where one of the following conditions exists:

1. The combined Group B occupant load of all floors is 500 or more.
2. The Group B occupant load is more than 100 persons above or below the lowest level of exit discharge.
3. The Group B fire area contains a Group B ambulatory health care facility.
4. A Group B building is three (3) or more stories in height.

Exception: Manual fire alarm boxes are not required where the building is equipped throughout with an automatic sprinkler system installed in accordance with Section 903.3.1.1 and the occupant notification appliances will activate throughout the notification zones upon sprinkler water flow.

907.6.2.3.1.1 Private Offices. Upon plan review, and a determination by the Fire Marshal's Office that devices are required, visible alarm notification or audible/visual alarm notification appliances shall be provided in private offices in Group B and E occupancies, when the private office is subject to limited visitation by students, parents, co-workers, or members of the general public.

907.2.8.2 Automatic smoke detection system. An automatic smoke detection system that activates the occupant notification system in accordance with Section 907.6 shall be installed throughout all interior corridors serving sleeping units. The automatic smoke detection system requirement is met only by the installation of smoke or beam detectors whenever possible. If environmental conditions do not allow the installation of smoke detectors, heat detectors may be used, on a limited basis, when approved by the Fire Marshal or his designee.

Exception: An automatic smoke detection system is not required in buildings that do not have interior corridors serving sleeping units and where each sleeping unit has a means of egress door opening directly to an exterior exit or to an exterior exit access that leads directly to an exit.

907.2.12.4 Special Provisions for High-Rise Buildings. The following special provisions shall apply to all buildings classified a high-rise structure as defined in the 2009 International Building Code.

1. The operation of any system smoke detector (not including guest room detector or dwelling unit detector), sprinkler, water flow device or manual fire alarm station shall automatically sound an alert signal to the floor of the incident, the floor above,

and the floor below, followed by voice instructions giving appropriate information and direction to occupants. Pre-recorded or live voice evacuation instructions from a constantly attended location on the premises to the occupants shall be permitted. Pre-recorded instruction shall be preceded by not less than five (5) seconds or more than ten (10) seconds of continuous alerting signal. The alarm signal may be an electronic sound, a horn, siren or Klaxon. Pre-recorded or live instructions shall be repeated 3 or more times. Upon completion or failure of pre-recorded instructions, the fire alarm evacuation signal must continue. Live voice instructions shall be permitted to interrupt the pre-recorded message or the fire alarm signal.

2. Actuation of the voice alarm system shall occur by any or all of the following means of initiation, but not limited thereto:
 - a. Manual pull stations
 - b. System smoke detector
 - c. Extinguishing system operation
3. A positive alarm sequence as defined in NFPA 72 is permitted where approved by the Fire Marshal or his designee. Request to use a positive alarm sequence feature must be made in writing and receive approval before installation. The feature of the positive alarm sequence system shall meet the requirements of NFPA 72.

907.2.13.1 Automatic smoke detection. Automatic smoke detection in high-rise buildings shall be in accordance with Sections 907.2.12.4, 907.2.13.1.1 and 8907.2.13.1.2.

907.2.24 High Occupant Load. In addition to the requirements listed in other sections of this code, any occupancy having an occupant load of 1,000 or more shall be provided with a manual fire alarm system.

Exception: Open parking garages

907.4.1 Duct smoke detectors. Smoke detectors installed in ducts shall be listed for the air velocity, temperature and humidity present in the duct. Duct smoke detectors shall be connected to the building's fire alarm control unit when a fire alarm system is required by Section 907.2. Activation of a duct smoke detector shall initiate a visible and audible supervisory signal at a constantly attended location and shall perform the intended fire safety function in accordance with this code and the International Mechanical Code. Duct smoke detectors shall not be used as a substitute for required open area detection.

Exceptions:

1. The supervisory signal at a constantly attended location is not required where duct smoke detectors activate the building's alarm notification appliances.
2. In occupancies not required to be equipped with a fire alarm system, actuation of a duct smoke detector shall activate a visible and an audible signal in an approved location. Smoke detector trouble conditions shall activate a visible or audible signal in an approved location and shall be identified as air duct detector trouble. Where a duct smoke detector is installed, there shall also be installed a remote test switch that includes a visual signal, audible signal, and a key operated test/reset switch.

907.5.2.1 Location. Manual fire alarm boxes shall be located not more than 5 feet (1524 mm) from the entrance to each exit. Additional manual fire alarm boxes shall be located so that travel distance to the nearest box does not exceed 200 feet (60 960 mm).

Exception: Where construction of the building prohibits the proper installation of a pull station (e.g., glass walls) a pull station shall be allowed to be located in the normal path of egress.

907.6.2.3.4 Group R-2. In Group R-2 occupancies required by Section 907 to have a fire alarm system, all dwelling units and sleeping units shall be provided with the capability to support visible alarm notification appliances in accordance with ICC A117.1. This requirement is met by extending the fire alarm wiring to all living areas, restroom, and sleeping areas of all units. The wiring must terminate in an electrical box suitable for securely mounting an audio/visual device. There shall be no more than ten devices designed for each circuit run. The building fire alarm wiring is to be extended to the unit smoke detectors so that the audible/visual alarm notification appliances may be connected to the building fire alarm system to notify residents with hearing impairments of an emergency situation. A smoke detector activated in an individual unit shall not set the entire complex into alarm.

907.10 Fire Alarm Systems – Emergency Control. At a minimum, the following functions, where provided, shall be activated by the fire alarm system:

1. Elevator capture and control in accordance with ASME/ANSI A17.1-2002, Safety Code for Elevators and Escalators
2. Release of automatic door closures
3. Stairwell and/or elevator shaft pressurization
4. Smoke management and/or smoke control systems

5. Emergency lighting control
6. Unlocking of doors
7. Emergency shutoff of gas and fuel supplies that may be hazardous providing the continuation of service is not essential to the preservation of life.

907.11 Special Provisions for Non-High-Rise Buildings.

These provisions apply to multi-floor structures not classified as a High-Rise structure as defined in the 2009 International Building Code.

1. The alarm signal may be an electronic sound, a horn, siren or Klaxon.
2. Alarm to sound at minimum on:
 - a. Floor of incident
 - b. Floor above
 - c. Floor below
3. Alarm to sound on signal from:
 - a. Manual pull stations
 - b. System smoke detector
 - c. Extinguishing system operation
4. A positive alarm sequence as defined in NFPA 72 is permitted where approved by the Fire Marshal or his designee. Request to use a positive alarm sequence feature must be made in writing and receive approval before installation. The feature of the positive alarm sequence system shall meet the requirements of NFPA 72.

907.12 Alarm Signal Silencing Switch. A switch for silencing the alarm signal sounding appliances shall be permitted only if it is key operated or located within a locked cabinet. Such a switch shall be permitted only if visible zone alarm indication or equivalent has been provided by approved annunciation, printout, or other approved means, and subsequent alarms on other initiating devices circuits will cause the audible alarm signaling appliances to resound. A switch that is left in the "silent" position when there is no alarm shall operate trouble signals until the switch is restored to normal.

SECTION 912 - FIRE DEPARTMENT CONNECTIONS

912.1 Installation. Fire department connections shall be installed in accordance with the NFPA standard applicable to the system design and shall comply with Sections 912-2 912.1.1 through 912.6.

912.1.1 Free Standing FDC. Installation of free standing Fire Department Connection shall not be less than two (2) feet above grade, or more than (3) feet above grade.

912.1.2 Building mounted FDC. Installation of the FDC on a building shall not be less than two (2) feet above grade, or more than three (3) feet above grade.

912.3.1 Locking fire department connection caps. The fire code official is authorized to require locking KNOX caps on fire department connections for water-based fire protection systems where the responding fire department carries appropriate key wrenches for removal.

CHAPTER 10 - MEANS OF EGRESS

[B] SECTION 1004 - OCCUPANT LOAD

TABLE 1004.1.1
MAXIMUM FLOOR AREA ALLOWANCES PER OCCUPANT

FUNCTION OF SPACE	FLOOR AREA IN SQ. FT. PER OCCUPANT
Accessory storage areas, mechanical equipment room	300 gross
Agricultural building	300 gross
Aircraft hangars	500 gross
Airport terminal	
Baggage claim	20 gross
Baggage handling	300 gross
Concourse	100 gross
Waiting areas	15 gross
Assembly – Gaming floors (keno, slots, etc.)	11 gross
Assembly with fixed seats	See Sec. 1004.7
Assembly without fixed seats	
Concentrated (chairs only-not fixed)	7 net
Standing space	5 net
Unconcentrated (tables and chairs)	15 net
Bowling centers, allow 5 persons for each lane including 15 feet of runway, and for additional areas	7 net
Business areas (<u>Administrative areas</u>)	100 gross
Courtrooms – other than fixed seating areas	40 net
Day care (<u>including after-school care facilities</u>)	35 net
Dormitories	50 gross
Educational	
Classroom area	20 net
Shops and other vocational room areas	50 net
Exercise rooms and <u>Gymnasiums</u>	50 gross
H-5 Fabrication and H-5 manufacturing areas	200 gross
Industrial areas, <u>Manufacturing areas</u>	100 gross
Institutional areas	
Inpatient treatment areas	240 gross
Outpatient areas	100 gross
Sleeping areas	120 gross
Kitchens, commercial	200 gross
Locker rooms	50 gross
Library	
Reading rooms	50 net
Stack areas	100 gross
Mercantile	
Areas on other floors	60 gross
Basement and grade floor levels	30 gross
Storage, stock, shipping areas	300 gross
Parking garages	200 gross

Residential	200 gross
Skating rinks, swimming pools	
Rink and pool	15 gross
Deck	50 gross
Stages and platforms	15 net
Warehouses	500 gross

For SI: 1 square foot = 0.0929 m2.

[B] SECTION 1006 - MEANS OF EGRESS ILLUMINATION

[B] 1006.3 Illumination emergency power. The power supply for means of egress illumination shall normally be provided by the premises' electrical supply. In the event of power supply failure, an emergency electrical system shall automatically illuminate the following areas:

1. Aisles and unenclosed egress stairways in rooms and spaces that require two or more means of egress.
2. Corridors, exit enclosures and exit passageways in buildings required to have two or more exits.
3. Exterior egress components at other than the level of exit discharge until exit discharge is accomplished for buildings required to have two or more exits.
4. Interior exit discharge elements, as permitted in Section 1024.1, in buildings required to have two or more exits.
5. Exterior landings, as required by Section 1008.1.5, for exit discharge doorways in buildings required to have two or more exits.
6. Group E occupancy stairs, corridors, windowless areas with student occupancy, shops, and laboratories.

The emergency power system shall provide power for a duration of not less than 90 minutes and shall consist of storage batteries, unit equipment or an on-site generator. The installation of the emergency power system shall be in accordance with Section 2702 of the International Building Code.

[B] SECTION 1008 - DOORS, GATES AND TURNSTILES

[B] 1008.1.9.10 Stairway doors. Interior stairway means of egress doors shall be openable from both sides without the use of a key or special knowledge or effort.

Exceptions:

1. Stairway discharge doors shall be openable from the egress side and shall only be locked from the opposite side.
2. This section shall not apply to doors arranged in accordance with Section 403.12 of the *International Building Code*.
3. In stairways ~~servicing not more than four stories~~, doors are permitted to be locked from the side opposite the egress side, provided they are openable from the egress side and capable of being unlocked simultaneously without unlatching upon a signal from the fire command center, if present, or a signal by emergency personnel from a single location inside the main entrance to the building.

1008.1.9.10.1 Stairway Identification and Re-Entry Identification. Where no re-entry is provided from the stairs to any floor, the sign shall read 'No Re-Entry'. In such case a sign of same dimensions shall be on the corridor side of the stair door at each floor level to read 'No Re-Entry From This Stair'. Each sign shall be no less than 8" x 11" in size, with lettering in a color that is easily visible and contrasts against the color of the sign itself. All lettering shall be no less than 1" in height, with strokes no less than ¼" in diameter.

1008.1.9.10.2 Re-Entry Identification Signs. Where stairway re-entry is provided to specific floors:

- a. On the stair side of the door where re-entry is provided, the sign shall read 'Re-Entry on This Floor'
- b. Where no re-entry is provided on that floor, the sign on the stair side of the door shall read 'No Re-Entry on the ' _____ ' and ' _____ ' Floors'. Also, a sign shall be placed on the corridor side of floors where re-entry is locked to read 'No Re-Entry'.

CHAPTER 23 - HIGH-PILED COMBUSTIBLE STORAGE

SECTION 2305 - HOUSEKEEPING AND MAINTENANCE

2305.6 Designation of storage heights. Where required by the fire code official, a visual method of indicating the maximum allowable storage height shall be provided. The owner and/or tenant of premises subject to this section shall

provide and maintain conspicuous markings on the walls and columns indicating the maximum permissible storage height.

CHAPTER 27 - HAZARDOUS MATERIALS—GENERAL PROVISIONS

SECTION 2703 - GENERAL REQUIREMENTS

2703.4.1 Material Safety Data Sheet Submittal. The Fire Marshal or his designee may require that information on the nature of any and all potentially hazardous material be submitted to the Fire Marshal's Office on the Standard Materials Safety Data Sheet provided by the U.S. Department of Labor Occupational Safety and Health Administration.

CHAPTER 29 - COMBUSTIBLE FIBERS

SECTION 2906 - CONSTRUCTION AND PROTECTION REQUIREMENTS

2906.1 Handling and storage. Handling and storage of large quantities of waste paper, rags, or other combustible materials shall not be allowed in a building of any type classification in excess of one thousand five hundred square feet area, unless the building is protected by an approved automatic sprinkler system.

2906.2 Construction type. Handling and storage buildings for waste paper, rags, and other combustible materials shall not exceed one story in height, unless of Type I construction and fully protected with an approved automatic sprinkler system.

2906.3 Materials outside of building. No loose waste paper, rags, trash or rubbish of any kind, or similar combustible materials shall be allowed on the premises on the outside of any building.

Exception: Baled materials may be stored outside of a building within twenty-five (25) feet of outside wall of building when a wall sprinkler curtain is provided on the building.

2906.4 Baled storage. Baled waste paper, rags, and other combustibles in baled lots, shall be stored in buildings providing the materials are stored in rows not exceeding twenty-five thousand (25,000) cubic feet of stored materials.

CHAPTER 33 – EXPLOSIVES AND FIREWORKS

See Bexar County Explosives Ordinance for all matters related to storage, licensing, and use of explosives.

CHAPTER 34 - FLAMMABLE AND COMBUSTIBLE LIQUIDS

SECTION 3401 - GENERAL

3401.4.1 Permit required prior to installation.

Application for permit shall be accompanied by two (2) copies of a diagram or drawing on scale showing the proposed location of the tank with reference to nearby buildings, streets, and waterways and showing in detail all proposed pipelines, pumps, and other improvements. Applications for installation over the Edwards Aquifer shall be reviewed by the Edwards Aquifer Authority prior to submittal to the Fire Marshal's Office for permitting.

SECTION 3403 - GENERAL REQUIREMENTS

3403.6.12 Pressurized piping. Where a pressurized (remote pumped) piping system is connected to a tank, the piping system shall have an approved leak detection device installed in the system to monitor for leaks in the piping.

SECTION 3404 – STORAGE

3404.2.11.5.2 Leak detection. Underground storage tank systems shall be provided with an approved method of leak detection from any component of the system that is designed and installed in accordance with NFPA 30. The following are approved methods of leak detection:

1. Manual tank gauging (for tanks less than 1,000 gallons)
2. Automatic tank gauging and inventory control
3. Vapor monitoring
4. Groundwater monitoring
5. Interstitial monitoring of double-wall systems
6. Monitoring of systems with secondary containment barriers
7. Statistical Inventory Reconciliations (SRS) – (for tanks and lines) NOTE: Documentation of performance claims for the SIR method must show the system's ability to detect releases of 0.1 g.p0.h.

with 95% or more probability of detection and 5% or less probability of false alarm.

3404.2.12.1 Acceptance testing. Prior to being placed into service, tanks shall be tested in accordance with Section 4.4 of NFPA 30. For new storage facilities, after installation of the underground tank into the tank excavation and before being completely covered, each tank shall be tested for tightness hydrostatically or pneumatically at not less than 3 pounds nor more than 5 pounds per square inch for one (1) hour. Pneumatic testing shall not be used on a tank containing flammable or combustible liquids or vapors.

3404.2.13 Abandonment and status of tanks. Tanks taken out of service shall be removed in accordance with Section 3404.2.14, or safeguarded in accordance with Sections 3404.2.13.1 through 3404.2.13.2.3 and API 1604. Before an underground tank is removed, a permit shall be obtained from the Fire Marshal's Office. Prior to transporting any removed tank, it shall be properly marked and inerted in the presence of the Fire Marshal or his designee.

CHAPTER 46 - CONSTRUCTION REQUIREMENTS FOR EXISTING BUILDINGS

CHAPTER 4601 - GENERAL

4601.1 Scope. The provisions of this chapter shall apply to all existing buildings constructed prior to the adoption of ~~this code~~ the 2003 International Fire Code or 2003 International Building Code.

4601.4 Owner notification. Where a building is found to be in noncompliance, the fire code official shall duly notify the owner of the building. Upon receipt of such notice, the owner shall, subject to the following time limits, take necessary actions to comply with the provisions of this chapter and the provisions of the Commissioners Court Order Adopting a Fire Code and Regulations for its Enforcement Pursuant to Chapter 233 of the Texas Local Government Code.

4601.4.1 Construction documents. Construction documents for the necessary alterations shall be completed within a time schedule approved by the fire code official. Within 30 days after receipt of owner notification, the owner shall submit to the Fire Marshal's Office, a letter indicating the owners

proposed plan and timeline to complete the required work to bring the building into code compliance.

4601.4.1.1 The Fire Marshal's Office will evaluate the submitted plan to determine if the proposed timelines are reasonable and achievable, determine alternative fire protection measures that can reasonably be implemented during the plan implementation period, and consult with the owner on developing an interim fire protection plan.

4601.4.1.2 If the submitted plan is determined to be unreasonable to bring the building into code compliance, the Fire Marshal's Office shall establish a minimum timeline in which the owner shall complete the required work.

4601.4.2 Completion of work. Work on the required alterations to the building shall be completed within a time schedule approved by the fire code official.

4601.4.3 Extension of time. The fire code official is authorized to grant necessary extensions of time when it can be shown that the specified time periods are not physically practical or pose an undue hardship. The granting of an extension of time for compliance shall be based on the showing of good cause and subject to the filing of an acceptable systematic plan of correction with the fire code official.

APPENDIX A

BOARD OF APPEALS

The provisions contained in this appendix are not mandatory unless specifically referenced in the adopting ordinance.

SECTION A101 – GENERAL

A101.1 Scope. A board of appeals shall be established within the jurisdiction for the purpose of hearing applications for modification of the requirements of the *International Fire Code* pursuant to the provisions of Section 108 of the *International Fire Code*. The board shall be established and operated in accordance with this section, and shall be authorized to hear evidence from appellants and the fire

code official pertaining to the application and intent of this code for the purpose of issuing orders pursuant to these provisions.

A101.2 Membership. The membership of the board shall consist of five voting members having the qualifications established by this section, residing in Bexar County, who are not employees of the jurisdiction. Members shall be nominated by the fire code official or the chief administrative officer of the jurisdiction. The board of appeals shall be appointed by the governing body, subject to confirmation by a majority vote of the governing body, and shall hold office at its pleasure. Members shall serve without remuneration or compensation, and shall be removed from office prior to the end of their appointed terms only for cause.

A101.2.1 Design professional (Architect). One member shall be a practicing design professional registered in the practice of ~~engineering or~~ architecture in the state in which the board is established.

A101.2.1.1 Design professional (Engineer). One member shall be a practicing design professional registered in the practice of engineering in the state in which the board is established.

A101.2.2 Fire protection engineering professional. One member shall be a qualified engineer, technologist, technician or safety professional trained in fire protection engineering, fire science or fire technology. Qualified representatives in this category shall include fire protection contractors and certified technicians engaged in fire protection system design, and shall include persons certified by the International Code Council as a Building Plans Examiner, Commercial Building Inspector, or Residential Building Inspector.

~~**A101.2.3 Industrial safety professional.** One Member shall be a registered industrial or chemical engineer, certified hygienist, certified safety professional, certified hazardous materials manager or comparably qualified specialist experienced in chemical process safety or industrial safety.~~

A101.2.4 General contractor (Builder). One member shall be a contractor regularly engaged in the construction, alteration, maintenance, repair or remodeling of buildings or building services and systems regulated by the code.

A101.2.5 General industry or business representative (Member of the Public). One member shall be a representative of business or industry not represented by a

member from one of the other categories of board members described above.

A101.3 Terms of office. Members shall be appointed for terms of four years. No member shall be reappointed to serve more than two consecutive full terms.

A101.3.1 Initial appointments. Of the members first appointed, two shall be appointed for a term of 1 year, two for a term of 2 years, one for a term of 3 years.

A101.3.2 Vacancies. Vacancies shall be filled for an unexpired term in the manner in which original appointments are required to be made. Members appointed to fill a vacancy in an unexpired term shall be eligible for reappointment to two full terms.

A101.3.3 Removal from office. Members shall be removed from office prior to the end of their terms only for cause. Continued absence of any member from regular meetings of the board shall, at the discretion of the applicable governing body, render any such member liable to immediate removal from office.

A101.4 Quorum. Three members of the board shall constitute a quorum. In varying the application of any provisions of this code or in modifying an order of the fire code official, affirmative votes of the majority present, but not less than three, shall be required.

A101.5 Secretary of board. The fire code official or his designee shall act as secretary of the board and shall keep a detailed record of all its proceedings, which shall set forth the reasons for its decisions, the vote of each member, the absence of a member and any failure of a member to vote.

A101.6 Legal counsel. The jurisdiction shall furnish legal counsel to the board to provide members with general legal advice concerning matters before them for consideration. Members shall be represented by legal counsel at the jurisdiction's expense in all matters arising from service within the scope of their duties.

A101.7 Meetings. The board shall meet at ~~regular intervals~~ at a minimum of twice a year, to be determined by the chairman. In any event, the board shall meet within 10 days after notice of appeal has been received.

A101.8 Conflict of interest. Members with a material or financial interest in a matter before the board shall declare such interest and refrain from participating in discussions, deliberations, and voting on such matters.

A101.9 Decisions. Every decision shall be promptly filed in writing in the office of the fire code official and shall be open to public inspection. A certified copy shall be sent by mail or otherwise to the appellant, and a copy shall be kept publicly posted in the office of the fire code official for 2 weeks after filing.

A101.10 Procedures. The board shall be operated in accordance with the Administrative Procedures Act of the state in which it is established or shall establish rules and regulations for its own procedure not inconsistent with the provisions of this code and applicable state law.

APPENDIX D

FIRE APPARATUS ACCESS ROADS

SECTION D103 - MINIMUM SPECIFICATIONS

D103.2 Grade. Fire apparatus access roads shall not exceed 10 percent in grade.

Exception: Grades steeper than 10 percent as approved by the ~~fire chief~~ Fire Marshal or his designee.

- 1) All grades in excess of 10%, but not in excess of 12.0%, may be approved when all of the following conditions exist:
 - a) The length of the grade does not exceed 300 feet from the beginning point of the grade to the termination point of the grade.
 - b) The termination point of the grade is not within 150 feet of a down-hill intersection, cul-de-sac, or hammerhead.
 - c) The last 75 feet of a down-hill slope approaching an intersection is not greater than 5%.
 - d) A grade indicating sign, showing the international symbol for a grade, as well as the numerical percentage of the grade, is installed within 75 feet of the start of both the up-hill and down-hill portions of the grade.
- 2) Grades in excess of 12.0 percent as approved by the Fire Marshal or his designee. All grades of 12% or greater may be approved when **all** of the following conditions exist:
 - a) The termination point of the grade is not within 150 feet of a down-hill intersection, cul-de-sac, or hammerhead.

- b) The last 75 feet of a down-hill slope approaching an intersection is not greater than 5%.
- c) A grade indicating sign, showing the international symbol for a grade, as well as the numerical percentage of the grade, is installed within 75 feet of the start of both the up-hill and down-hill portions of the grade.
- d) All structures on a fire department access road with a grade greater than 12.0% are provided with a public water supply sufficient to meet the fire flow requirements of Table B105.1 and hydrant distribution to meet the requirement of Table C105.1.
- e) **ALL** structures regulated by the International Building Code with property access off a fire department access road with a grade of 12% or greater **MUST** be provided with a fire sprinkler system in accordance with Section 903.3.

D103.5 Fire apparatus access road gates. Gates securing the fire apparatus access roads shall comply with all of the following criteria:

1. The minimum gate width shall be ~~20~~ 16 feet (6096 mm).
2. Gates shall be of the swinging or sliding type.
3. Construction of gates shall be of materials that allow manual operation by one person.
4. Gate components shall be maintained in an operative condition at all times and replaced or repaired when defective.
5. Electric gates shall be equipped with a ~~means of~~ Siren Operated Sensor system for opening the gate by fire department personnel by activation of the emergency vehicle siren for emergency access. ~~Emergency S.O.S.~~ opening devices shall be approved by the fire code official.
6. Manual opening gates shall not be locked with a padlock or chain and padlock unless they are capable of being opened by means of forcible entry tools or when a key box containing the key(s) to the lock is installed at the gate location.
 - Exception:** Knox[®] padlocks authorized by the Authority Having Jurisdiction.
7. Locking device specifications shall be submitted for approval by the fire code official.

The following Sections of the 2009 International Building Code shall read as follows:

In the following document, an underlined word or sentence is a Bexar County regulation that has been added; a ~~strike through~~ is a word or sentence removed as a Bexar County regulation.

2009 International Building Code Rules: Changes affecting any code section will be displayed under the appropriate section.

CHAPTER 1 - ADMINISTRATION

SECTION 103 - FIRE CODE ENFORCEMENT

SECTION DEPARTMENT OF BUILDING SAFETY

103.1 Creation of enforcement agency. ~~The Department of Building Safety~~ Bexar County Fire Marshal's Office is hereby created and the official in charge thereof shall be known as the building official.

103.1.1 BUILDING CODE OFFICIAL – DEFINED.

Throughout the 2009 International Building Code, where the term building official is used, it shall mean the Bexar County Fire Marshal.

103.1.2 FIRE CODE ENFORCEMENT & FIRE PREVENTION

SECTION – DEFINED. Throughout the 2009 International Building Code, where the term department of building safety is used, it shall mean the Bexar County Fire Marshal's Office, Fire Code Enforcement and Fire Prevention Sections.

103.2 Appointment. ~~The building official shall be appointed by the chief appointing authority of the jurisdiction~~ Bexar County Commissioners Court.

103.3 Deputies. In accordance with the prescribed procedures of this jurisdiction and with the concurrence of the Bexar County Commissioners Court ~~appointing authority~~, the building official shall have the authority to appoint a deputy building official, the related technical officers, inspectors, plan examiners and other employees. Such employees shall have powers as delegated by the building official. For the maintenance of existing properties, see the *International Property Maintenance Code*.

SECTION 104 - DUTIES AND POWERS OF BUILDING OFFICIAL

104.6 Right of entry. Where it is necessary to make an inspection to enforce the provisions of this code, or where the building official has reasonable cause to believe that there exists in a structure or upon a premises a condition which is contrary to or in violation of this code which makes the structure or premises unsafe, dangerous or hazardous, the building official or his designee is authorized to enter the

structure or premises at reasonable times to inspect or to perform the duties imposed by this code, provided that if such structure or premises be occupied that credentials be presented to the occupant and entry requested. If such structure or premises is unoccupied, the building official or his designee shall first make a reasonable effort to locate the owner or other person having charge or control of the structure or premises and request entry. If entry is refused, the building official or his designee shall have recourse to the remedies provided by law to secure entry.

104.6.1 Dangerous or Damaged Structures.

The Fire Marshal or his designee shall examine, or cause to be examined, every building or structure or portion thereof reported as dangerous or damaged. If such is found to be unsafe as defined in this section, the Fire Marshal or his designee shall give the owner of such building or structure written notice stating the defects thereof. This notice shall require the owner or person in charge of the building, structure or premises, within 72 hours to commence either the required repairs or improvements or demolition and removal of the building or structure or portions thereof. All such work shall be completed within 60 days from the date of notice unless otherwise stipulated by the Fire Marshal. Service of notice shall be made in person by the Fire Marshal or his designee or by certified mail upon the owner or his agent. The designated period within which said owner or agent is required to comply with the order shall begin as of the date the owner or occupant received such notice.

SECTION 105 - PERMITS AND WORK AUTHORIZATIONS

105.1 Required. Any owner or authorized agent who intends to construct, enlarge, alter, repair, move, demolish, or change the occupancy of a building or structure, or to erect, install, enlarge, alter, repair, remove, convert or replace any electrical, gas, mechanical or plumbing system, the installation of which is regulated by this code, or to cause any such work to be done, shall first make application to the building official or his designee and obtain the required permit or work authorization.

~~105.1.1 Annual permit. In lieu of an individual permit for each alteration to an already approved electrical, gas, mechanical or plumbing installation, the building official is authorized to issue an annual permit upon application therefore to any person, firm or corporation regularly employing one or more qualified trade persons in the building, structure or on the premises owned or operated by the applicant for the permit.~~

~~105.1.2 Annual permit records. The person to whom an annual permit is issued shall keep a detailed record of alterations made under such annual permit. The building official shall have access to such records at all times or such records shall be filed with the building official as designated.~~

105.3.1 Action on application. The building official or his designee shall examine or cause to be examined applications for permits and amendments thereto within a reasonable time 30 days after filing. Such applications may be reviewed by other departments of the County to verify compliance with any applicable laws and commissioners court orders under their jurisdiction. If the application or the construction documents do not conform to the requirements of pertinent laws and commissioners court orders, the building official or his designee shall reject such application in writing, stating the reasons therefore. The 30 day limit to review and approve construction documents shall terminate on the date the documents are found to not comply with the building or fire code; the time limit shall start over on the date corrected documents are submitted for review. If the building official or his designee is satisfied that the proposed work conforms to the requirements of this code and laws and ordinances commissioners court orders, applicable thereto, the building official or his designee shall issue a permit therefore as soon as practicable.

105.7 Placement of permit. The reviewed building plans and building permit or copy shall be kept readily available on the site of the work at all times work is being performed until the completion of the project.

SECTION 108 – TEMPORARY STRUCTURES AND USES

108.1 General. The building official is authorized to issue a permit for temporary structures and temporary uses. Such permits shall be limited as to time of service, but shall not be permitted for more than ~~480~~ 365 days. The building official is authorized to grant extensions for demonstrated cause.

108.3 Temporary Power. The building official is authorized to give permission to temporarily supply and use power in part of an electric installation before such installation has been fully completed and the final certificate of completion has been issued. The building official is authorized to deny permission to temporarily supply and use power. The part of a structure covered by the temporary certificate shall comply with the requirements specified for temporary lighting, heat or power in NFPA 70.

SECTION 109 - FEES

109.1 Payment of fees. A permit shall not be valid until the fees prescribed by law have been paid, nor shall an amendment to a permit be released until the additional fee, if any, has been paid.

109.1.1 Submittal Fees. Permit fees paid to the County are non-refundable. All fees for plan review, building permit, construction inspections, final inspection and the issuance of a Certificate of Compliance (aka Certificate of Occupancy) shall be paid at the time construction documents are submitted to the County.

109.1.2 Resubmittals. Construction documents that have been resubmitted after corrections are made will be reviewed at no additional cost. If documents are denied and returned for further corrections, the third submittal of the same documents shall be considered a new submittal and pay all applicable permitting fees for a new project.

109.3 Building permit valuations. The applicant for a permit shall provide an estimated permit value at time of application. Permit valuations shall include total value of work, including materials and labor, for which the permit is being issued, such as electrical, gas, mechanical, plumbing equipment and permanent systems. If, in the opinion of the building official, the valuation is underestimated on the application, the permit shall be denied, unless the applicant can show detailed estimates to meet the approval of the building official. Final building permit valuation shall be set by the building official.

109.3.1 Bexar County building permit valuations. Building construction cost values will be determine at not less than \$60.00 per square foot unless detailed estimates are submitted at the time of submittal indicating a lower total value.

109.4 Work commencing before permit issuance. Any person who commences any work on a building, structure, electrical, gas, mechanical or plumbing system before obtaining the necessary permits or work authorizations shall be subject to a fee established by the building official that shall be in addition to the required permit fees. No work shall be started at a new construction site or an existing structure, other than maintenance work, without a permit being issued or by approval to begin work by the Fire Marshal or his designee. Both the individual contractor along with the site general contractor will be held liable for such actions. Where work is commenced prior to obtaining said permit, the permit fees shall be increased by twice the original permit fee amount, but payment of the increased fee shall not relieve any person from fully complying with the requirements to obtain a permit, nor of any other penalties herein.

SECTION 110 - INSPECTIONS

110.3 Required inspections. The building official or his designee, upon notification, shall make any or all of the inspections set forth in Sections 110.3.1 through 110.3.10 as well as any other inspection necessary to ensure compliance with the Building Code or Fire Code.

SECTION 111 - CERTIFICATE OF COMPLIANCE OR OCCUPANCY

111.1 Use and occupancy. No building or structure shall be used or occupied, and no change in the existing occupancy classification of a building or structure or portion thereof shall be made until the building official or his designee has issued a certificate of (compliance) occupancy therefore as provided herein. No physical change of occupant for occupancy groups A-2 (Assembly uses intended for food and/or drink consumption including, but not limited to, banquet halls, night clubs, restaurants, taverns and bars) and E (Educational) of a building or portion thereof shall be made until the building has been inspected and issued a certificate of (compliance) occupancy. Issuance of a certificate of (compliance) occupancy shall not be construed as an approval of a violation of the provisions of this code or of other state laws or commissioners court orders ordinances of the jurisdiction.

SECTION 113 - BOARD OF APPEALS

~~**113.1 General.** In order to hear and decide appeals of orders, decisions or determinations made by the building official relative to the application and interpretation of this code, there shall be and is hereby created a board of appeals. The board of appeals shall be appointed by the governing body and shall hold office at its pleasure. The board shall adopt rules of procedure for conducting its business.~~

113.1 Board of appeals established. In order to hear and decide appeals of orders, decisions or determinations made by the building official relative to the application and interpretation of this code, there shall be and is hereby created a board of appeals consisting of 5 persons residing in Bexar County, who are not employees of the jurisdiction. The board should consist of one (1) structural engineer, one (1) architect, one (1) builder, one (1) member of the public, and one (1) person certified by the International Code Council as a Building Plans Examiner, Commercial Building Inspector, or Residential Building Inspector. The board of appeals shall be appointed by the governing body and shall hold office at its pleasure. The term of office shall not exceed two (2) years and shall be limited to three (3) consecutive two-year terms. All vacancies shall be filled for the unexpired portion of the term only. The building official or his designee shall be an ex officio member of said board but shall have no vote on any matter before the board. The board shall adopt rules of procedure for conducting its business- and shall render all decisions and findings in writing to the appellant with a duplicate copy to the building official.

SECTION 114 - VIOLATIONS

114.1 Unlawful acts. It shall be unlawful for any person, firm or corporation to erect, construct, alter, extend, repair, move, remove, demolish or occupy any building, structure or equipment regulated by this code, or cause same to be done, in conflict with or in violation of any of the provisions of this code. No work shall be started at a new construction site or an existing structure, other than maintenance work, without a permit or work authorization being issued or by approval to begin work by the Fire Marshal or his designee. Both the individual contractor along with the site general contractor will be held liable for such actions. Where work is commenced prior to obtaining said permit, the permit fees shall be doubled, but payment of the increased fee shall not relieve any person from fully complying with the requirements to obtain a permit, nor of any other penalties herein.

114.2 Notice of violation. The building official or his designee is authorized to serve a notice of violation or stop-work order on the person responsible for the erection, construction,

alteration, extension, repair, moving, removal, demolition or occupancy of a building or structure in violation of the provisions of this code, or in violation of a permit or certificate issued under the provisions of this code. Such order shall direct the discontinuance of the illegal action or condition and the abatement of the violation.

114.3 Prosecution of violation. If the notice of violation is not complied with promptly, the building official or his designee is authorized to request the legal counsel of the jurisdiction to institute the appropriate proceeding at law or in equity to restrain, correct or abate such violation, or to require the removal or termination of the unlawful occupancy of the building or structure in violation of the provisions of this code or of the order or direction made pursuant thereto.

114.4 Violation penalties. Any person who violates a provision of this code or fails to comply with any of the requirements thereof or who erects, constructs, alters or repairs a building or structure in violation of the approved construction documents or directive of the building official, or of a permit or certificate issued under the provisions of this code, shall be subject to penalties as prescribed by law. Refer to the 2009 International Fire Code, Section 109.3.1 for Offense Penalties

CHAPTER 2 – DEFINITIONS

SECTION 202 - GENERAL DEFINITIONS

shall include the following definitions:

AUTHORIZED EMERGENCY VEHICLE shall have the meaning set out in the Texas Transportation Code §541.201.

CERTIFICATE OF COMPLIANCE; CERTIFICATE OF OCCUPANCY. A certificate, issued according to Section 110 of the 2009 International Building Code, stating that all materials, products, and construction meet or exceed specified standards, approved construction documents, and all applicable Codes or laws. Issuance of a certificate of occupancy shall not be construed as an approval of a violation of the provisions of this code or of other ordinances of the jurisdiction. The terms Certificate of Compliance and Certificate of Occupancy shall be interchangeable and hold the same meaning, wherever used.

COMMERCIAL ESTABLISHMENT means a place where goods and commodities or services are displayed, exchanged, sold or bought.

FIRE LANE shall mean any area appurtenant to entrances or exits of a building deemed necessary by the Fire Marshal or his designee to remain free and clear of parked vehicles for access to such building in case of fire or other emergency and designated by him as such, and may include sidewalks, driveways, portions of parking lots, or any other area adjacent to or near building entrances or exits, or any fire hydrant. Fire lanes identified or designated by the Fire Marshal or his designee shall be conspicuously marked and identified as set out in the Texas Transportation Code §684.011(c).

PUBLIC BUILDING; PUBLIC ACCESS BUILDING; PUBLIC ACCESSIBLE BUILDING means a place in which the possession and/or use, as well as the property in it, gives members of the public free access or use and includes buildings in which the public may enter, including where an entry fee is charged; or otherwise comply with the requirements of an “Occupiable Space” as defined in the 2009 International Building Code.

MULTI-FAMILY DWELLING means any residential structure consisting of four (4) or more residential dwelling units. (Dwelling Unit - A single unit providing complete, independent living facilities for one or more persons, including permanent provisions for living, sleeping, eating, cooking and sanitation.) These buildings are typically, but not always, classified within the Group “R” occupancy classification.

OCCUPANT means any person, agent, firm, or corporation that occupies a building or part thereof as an owner or tenant.

CHAPTER 5 - GENERAL BUILDING HEIGHTS AND AREAS

SECTION 501 - GENERAL

[F] 501.2 Address identification. New and existing buildings shall be provided with approved address numbers or letters. Each character shall be a minimum 4 six (6) inches (402 152.4mm) high and a minimum of 0.5 inch (12.7 mm) wide. They shall be installed on a contrasting background and be plainly visible from the street or road fronting the property. Where access is by means of a private road and the building address cannot be viewed from the public way, a monument, pole or other approved sign or means shall be used to identify the structure.

501.2.1 Multi-Building Complexes. Where there are multiple buildings at a single property address, each building shall have building number(s) meeting the requirements of 501.2 posted on the building in a

location that is plainly legible and visible from the driving surface closest to the building.

CHAPTER 9 - FIRE PROTECTION SYSTEMS

SECTION 903 - AUTOMATIC SPRINKLER SYSTEMS

[F] 903.3.1.2 NFPA 13R sprinkler systems. Where allowed in buildings of Group R, up to and including four stories in height, automatic sprinkler systems shall be installed throughout in accordance with NFPA 13R.

[F] 903.3.1.2.1 Balconies and decks. Sprinkler protection shall be provided for exterior balconies, decks and ground floor patios of dwelling units where the building is of Type V construction. Sidewall sprinklers that are used to protect such areas shall be permitted to be located such that their deflectors are within 1 inch (25 mm) to 6 inches (152 mm) below the structural members and a maximum distance of 14 inches (356 mm) below the deck of the exterior balconies and decks that are constructed of open wood joist construction.

903.3.1.2.2 Attic Protection. In addition to the protection requirements of NFPA 13R, sprinkler protection shall be designed and provided in all attic spaces of Type V construction.

[F] 903.3.1.3 NFPA 13D sprinkler systems. Where allowed, automatic sprinkler systems installed in one and two-family dwellings shall be installed throughout in accordance with NFPA 13D.

903.3.1.3.1 Attic Protection. In addition to the protection requirements of NFPA 13D, sprinkler protection shall be designed and provided in all attic spaces of Type V construction.

903.6 Separation from Non-Sprinklered Areas. Unless otherwise exempted by the 2009 International Building Code (IBC) or 2009 International Fire Code (IFC) or required to be of a higher fire resistance construction by the IBC or IFC, a minimum of one (1) hour fire barrier construction in accordance with the 2006 IBC shall be provided between sprinklered and non-sprinklered areas within a building.

SECTION 904 – ALTERNATIVE AUTOMATIC FIRE-EXTINGUISHING SYSTEMS

904.11.1 Manual system operation. A manual actuation device shall be located at or near a means of egress from the cooking area a minimum of 10 feet (3048 mm) and a maximum of 20 feet (6096 mm) from the kitchen exhaust system. The manual actuation device shall be installed not more than 48 inches (1200 mm) nor less than 42 inches (1067 mm) above the floor and shall clearly identify the hazard protected. The manual actuation shall require a maximum force of 40 pounds (178 N) and a maximum movement of 14 inches (356 mm) to actuate the fire suppression system.

Exception: Automatic sprinkler systems shall not be required to be equipped with manual actuation means.

904.11.1.1 Manual system operation device color. The manual actuation device for an alternative fire-extinguishing system shall be silver or white in color, and shall not resemble a fire alarm system actuation device. The color of the manual actuation device for an alternative fire-extinguishing system shall apply to both commercial and residential fire-extinguishing systems.

904.11.1.2 Multiple manual system operation devices. Where there are multiple manual actuation devices for an alternative fire-extinguishing system, each actuation device and the corresponding fire extinguishing system shall be provided with an identification plate that indicates which system the device operates.

SECTION 907 - FIRE ALARM AND DETECTION SYSTEMS

[F] 907.2.2 Group B. A manual fire alarm system shall be installed in Group B occupancies where one of the following conditions exists:

1. The combined Group B occupant load of all floors is 500 or more.
2. The Group B occupant load is more than 100 persons above or below the lowest level of exit discharge.
3. The Group B fire area contains a Group B ambulatory health care facility.
4. In all Group B buildings three (3) or more stories.

Exception: Manual fire alarm boxes are not required where the building is equipped

throughout with an automatic sprinkler system installed in accordance with Section 903.3.1.1 and the occupant notification appliances will activate throughout the notification zones upon sprinkler waterflow.

907.6.2.3.1.1 Private Offices. Upon plan review, and a determination by the Fire Marshal's Office that devices are required, visible alarm notification or audible/visual alarm notification appliances shall be provided in private offices in Group B and E occupancies, when the private office is subject to limited visitation by students, parents, co-workers, or members of the general public.

[F] 907.2.8.2 Automatic smoke detection system. An automatic smoke detection system that activates the occupant notification system in accordance with Section 907.5 shall be installed throughout all interior corridors serving sleeping units. The automatic smoke detection system requirement is met only by the installation of smoke or beam detectors whenever possible. If environmental conditions do not allow the installation of smoke detectors, fire alarm heat detectors may be used, on a limited basis, when approved by the Fire Marshal or his designee.

Exception: An automatic smoke detection system is not required in buildings that do not have interior corridors serving sleeping units and where each sleeping unit has a means of egress door opening directly to an exit or to an exterior exit access that leads directly to an exit.

907.2.13.3 Special Provisions for High-Rise Buildings. The following special provisions shall apply to all buildings classified a high-rise structure as defined in the 2009 International Building Code.

1. The operation of any system smoke detector (not including guest room detector or dwelling unit detector), sprinkler, water flow device or manual fire alarm station shall automatically sound an alert signal to the floor of the incident, the floor above, and the floor below, followed by voice instructions giving appropriate information and direction to occupants. Pre-recorded or live voice evacuation instructions from a constantly attended location on the premises to the occupants shall be permitted. Pre-recorded instruction shall be preceded by not less than five (5) seconds or more than ten (10) seconds of continuous alerting signal. The alarm signal may be an electronic sounds, a horn, siren or Klaxon. Pre-recorded or live instructions shall be repeated 3 or

more times. Upon completion or failure of pre-recorded instructions, the fire alarm evacuation signal must continue. Live voice instructions shall be permitted to interrupt the pre-recorded message or the fire alarm signal.

2. Actuation of the voice alarm system shall occur by any or all of the following means of initiation, but not limited thereto:
 - a. Manual pull stations
 - b. System smoke detector
 - c. Extinguishing system operation
3. A positive alarm sequence as defined in NFPA 72 is permitted where approved by the Fire Marshal or his designee. Request to use a positive alarm sequence feature must be made in writing and receive approval before installation. The feature of the positive alarm sequence system shall meet the requirements of NFPA 72.

907.2.24 High Occupant Load. In addition to the requirements listed in other sections of this code, any occupancy having an occupant load of 1,000 or more shall be provided with a manual fire alarm system.

Exception: Open parking garages

[F] 907.3.1 Duct smoke detectors. Smoke detectors installed in ducts shall be listed for the air velocity, temperature and humidity present in the duct. Duct smoke detectors shall be connected to the building's fire alarm control unit when a fire alarm system is required by Section 907.2. Activation of a duct smoke detector shall initiate a visible and audible supervisory signal at a constantly attended location and shall perform the intended fire safety function in accordance with this code and the International Mechanical Code. Duct smoke detectors shall not be used as a substitute for required open area detection.

Exceptions:

1. The supervisory signal at a constantly attended location is not required where duct smoke detectors activate the building's alarm notification appliances.
2. In occupancies not required to be equipped with a fire alarm system, actuation of a smoke detector shall activate a visible and an audible signal in an approved location. Smoke detector trouble conditions shall activate a visible or audible signal in an approved location and shall be identified as air duct detector trouble. Where a duct smoke detector is installed, there shall also be installed a remote test switch that includes a visual signal, audible signal, and a key operated test/reset switch.

[F] 907.4.2.1 Location. Manual fire alarm boxes shall be located not more than 5 feet (1524 mm) from the entrance to each exit. Additional manual fire alarm boxes shall be located so that travel distance to the nearest box does not exceed 200 feet (60 960 mm).

Exception: Where construction of the building prohibits the proper installation of a pull station (e.g., glass walls) a pull station shall be allowed to be located in the normal path of egress travel.

[F] 907.5.2.3.4 Group R-2. In Group R-2 occupancies required by Section 907 to have a fire alarm system, all dwelling units and sleeping units shall be provided with the capability to support visible alarm notification appliances in accordance with ICC A117.1. This requirement is met by extending the fire alarm wiring to all living areas, restroom, and sleeping areas of all units. The wiring must terminate in an electrical box suitable for securely mounting an audio/visual device. There shall be no more than ten devices designed for each circuit run. The building fire alarm wiring is to be extended to the unit smoke detectors so that the audible/visual alarm notification appliances may be connected to the building fire alarm system to notify residents with hearing impairments of an emergency situation. A smoke detector activated in an individual unit shall not set the entire complex into alarm.

907.9 Fire Alarm Systems – Emergency Control. At a minimum, the following functions, where provided, shall be activated by the fire alarm system:

1. Elevator capture and control in accordance with ASME/ANSI A17.1-2002, Safety Code for Elevators and Escalators
2. Release of automatic door closures
3. Stairwell and or elevator shaft pressurization
4. Smoke management and/or smoke control systems
5. Emergency lighting control
6. Unlocking of doors
7. Emergency shutoff of gas and fuel supplies that may be hazardous providing the continuation of service is not essential to the preservation of life.

907.10 Special Provisions for Non-High-Rise Buildings. These provisions apply to multi-floor structures not classified as a High-Rise structure as defined in the 2009 International Building Code.

1. The alarm signal may be an electronic sound, a horn, siren or Klaxon.
2. Alarm to sound at minimum on:
3. Floor of incident
4. Floor above
5. Floor below
6. Alarm to sound on signal from:

- a. Manual pull stations
 - b. System smoke detector
 - c. Extinguishing system operation
7. A positive alarm sequence as defined in NFPA 72 is permitted where approved by the Fire Marshal or his designee. Request to use a positive alarm sequence feature must be made in writing and receive approval before installation. The feature of the positive alarm sequence system shall meet the requirements of NFPA 72.

907.11 Alarm Signal Silencing Switch. A switch for silencing the alarm signal sounding appliances shall be permitted only if it is key operated or located within a locked cabinet. Such a switch shall be permitted only if visible zone alarm indication or equivalent has been provided by approved annunciation, printout, or other approved means, and subsequent alarms on other initiating devices circuits will cause the audible alarm signaling appliances to resound. A switch that is left in the “silent” position when there is no alarm shall operate trouble signals until the switch is restored to normal.

CHAPTER 10 - MEANS OF EGRESS

[B] SECTION 1004 - OCCUPANT LOAD

TABLE 1004.1.1
MAXIMUM FLOOR AREA ALLOWANCES PER OCCUPANT

FUNCTION OF SPACE	FLOOR AREA IN SQ. FT. PER OCCUPANT
Accessory storage areas, mechanical equipment room	300 gross
Agricultural building	300 gross
Aircraft hangars	500 gross
Airport terminal	
Baggage claim	20 gross
Baggage handling	300 gross
Concourse	100 gross
Waiting areas	15 gross
Assembly – Gaming floors (keno, slots, etc.)	11 gross
Assembly with fixed seats	See Sec. 1004.7
Assembly without fixed seats	
Concentrated (chairs only-not fixed)	7 net
Standing space	5 net
Unconcentrated (tables and chairs)	15 net
Bowling centers, allow 5 persons for each lane including 15 feet of runway, and for additional areas	7 net
Business areas (Administrative areas)	100 gross
Courtrooms – other than fixed seating areas	40 net
Day care (including after-school care facilities)	35 net
Dormitories	50 gross
Educational	
Classroom area	20 net
Shops and other vocational room areas	50 net
Exercise rooms and Gymnasiums	50 gross
H-5 Fabrication and H-5 manufacturing areas	200 gross
Industrial areas, Manufacturing areas	100 gross
Institutional areas	
Inpatient treatment areas	240 gross
Outpatient areas	100 gross
Sleeping areas	120 gross
Kitchens, commercial	200 gross
Locker rooms	50 gross
Library	
Reading rooms	50 net
Stack areas	100 gross
Mercantile	
Areas on other floors	60 gross
Basement and grade floor levels	30 gross
Storage, stock, shipping areas	300 gross
Parking garages	200 gross
Residential	200 gross
Skating rinks, swimming pools	
Rink and pool	15 gross
Deck	50 gross
Stages and platforms	15 net
Warehouses	500 gross

For SI: 1 square foot = 0.0929 m².

SECTION 1008 - DOORS, GATES AND TURNSTILES

1008.1.4.5 Security grilles. In Groups B, F, M and S, horizontal sliding or vertical security grilles are permitted at the

main exit and shall be openable from the inside without the use of a key or special knowledge or effort during periods that the space is occupied. The grilles shall remain secured in the full-open position during the period of occupancy by the general public. Where two or more means of egress are required, not more than one-half of the exits or exit access doorways shall be equipped with horizontal sliding or vertical security grilles.

1008.1.4.5.1 Security Grilles in Means of Egress.

Where a security grille is installed in the means of egress in any occupancy group, it shall comply with all of the following:

1. The required minimum egress width shall not be reduced;
2. The grille shall be either spring-tension or motor operated;
3. When closed, the grille shall fully open, so as to not obstruct or reduce the minimum required egress width upon activation of the fire alarm system, upon loss of power, or activation of any other emergency notification/activation system.

SECTION 1026 - EXTERIOR EXIT RAMPS AND STAIRWAYS

1026.7 Exterior Fire Escape. Any existing exterior fire escape which is deemed to be an adequate fire escape under the laws of the state shall be deemed an adequate means of egress for emergency use, as required by the chapter, and the number of existing fire escapes shall be provided to comply with the fire escape law of the state fire prevention regulations.

CHAPTER 11- ACCESSIBILITY

SECTION 1102 - DEFINITIONS

ACCESSIBILITY. All buildings or portions of buildings must comply with the accessibility standards adopted by the state of Texas. Projects shall be submitted to the Texas Department of Licensing and Regulations for review, inspection, and approval in accordance with state law.

CHAPTER 15 - ROOF ASSEMBLIES AND ROOFTOP STRUCTURES

SECTION 1503 - WEATHER PROTECTION

[P] 1503.4 Roof drainage. Design and installation of roof drainage systems shall comply with Section 1503 and the International Plumbing Code.

1503.4.4 Zero Lot Line Development. On zero lot line development where roof projections are allowed by deed covenant or ingress/egress easements and the roof slopes towards the adjoining property, adequate gutters and down spouts shall be provided to direct roof water away from adjacent property. Roof projections shall not extend beyond a point 1/3 the width of the easement or a maximum of 24 inches. If there is no slope towards zero lot lines, gutters are not necessary.

1503.4.5 Group R and U occupancies. Any Group R or Group U occupancy with roof edges less than three (3) feet from any property line, shall be provided with gutters and down spouts to direct roof water away from adjacent property.

CHAPTER 17 - STRUCTURAL TESTS AND SPECIAL INSPECTIONS

SECTION 1704 - SPECIAL INSPECTIONS

1704.1 General. Where application is made for construction as described in this section, the owner or the registered design professional in responsible charge acting as the owner's agent shall employ one or more approved agencies to perform inspections during construction on the types of work listed under Section 1704. These inspections are in addition to the inspections identified in Section 110.

The special inspector shall not be employed by the contractor and shall be a qualified person, or an approved agency or firm, who shall demonstrate competence, to the satisfaction of the registered design professional in responsible charge and the building official, for the inspection of the particular type of construction or operation requiring special inspection. The registered design professional in responsible charge and engineers of record involved in the design of the project are permitted to act as the approved agency and their personnel

are permitted to act as the special inspector for the work designed by them, provided those personnel meet the qualification requirements of this section to the satisfaction of the building official. The special inspector shall provide written documentation to the building official demonstrating his or her competence and relevant experience or training. Experience or training shall be considered relevant when the documented experience or training is related in complexity to the same type of special inspection activities for projects of similar complexity and material qualities. These qualifications are in addition to qualifications specified in other sections of this code.

Exceptions:

1. Special inspections are not required for work of a minor nature or as warranted by conditions in the jurisdiction as approved by the building official.
2. Special inspections are not required for building components unless the design involves the practice of professional engineering or architecture as defined by applicable state statutes and regulations governing the professional registration and certification of engineers or architects.
3. Unless otherwise required by the building official, special inspections are not required for Group U occupancies that are accessory to a residential occupancy including, but not limited to, those listed in Section 312.1.

SPECIAL NOTES CONCERNING FIRE ALARM DEVICES

Recently there have been several questions concerning Audio or Audio/Visual devices in Group E occupancies. Based on information provided from the International Code Council, the Bexar County Fire Marshal's Office, under Section 102.9 of the 2009 edition of the International Fire Code, the Fire Marshal's Office, upon plan review will make the final determination when fire alarm audio or audio/visual devices ***shall*** be installed in principle, vice- or assistant-principle, counselor, or other staff offices as a minimum means of notification when the building fire alarm system is activated.

102.9 Matters not provided for. Requirements that are essential for the public safety of an existing or proposed activity, building or structure, or for the safety of the occupants thereof, which are not specifically provided for by this code shall be determined by the *fire code official*.

DRAFT