

Fire Ratings



Guideline on
Fire Ratings of Archaic Materials and Assemblies

Prepared for the
U.S. Department of Housing and Urban Development
Office of Policy Development and Research

by the National Institute of Building Sciences, Washington, D.C.
under Contract C-OPC-21204

February 2000



PATH (Partnership for Advancing Technology in Housing) is a new private/public effort to develop, demonstrate, and gain widespread acceptance for the "Next Generation" of American housing. Through the use of new and innovative technologies the goal of PATH is to improve the quality, durability, environmental efficiency, and affordability of tomorrow's houses.

Initiated at the request of the White House, PATH is managed and supported by the U.S. Department of Housing and Urban Development. In addition, all Federal Agencies that engage in housing research and technology development are PATH partners, including the Department of Energy, the Department of Commerce, the Environmental Protection Agency, and the Federal Emergency Management Agency. State and local governments and other participants in the public sector also are partners in PATH. Product manufacturers, home builders, insurance companies, and lenders represent private industry in the PATH partnership.

To learn more, please contact: PATH, Suite B133, 451 Seventh Street, S.W., Washington, D.C. 20410; fax 202-708-4250; e-mail pathnet@pathnet.org.

The statements and conclusions contained in this publication are those of the National Institute of Building Sciences and do not necessarily reflect the view of the Department of Housing and Urban Development. The Institute has made every effort to verify the accuracy and appropriateness of the publication's content. However, no guarantee of the accuracy or completeness of the information or acceptability for compliance with any industry standard or mandatory requirement of any code, law, or regulation is either offered or implied.

Foreword

Older buildings often contain materials that are fire safe but not listed in current fire ratings sources. This lack of documentation hinders the modernization and reuse of our nation's building stock. The *Guideline on Fire Ratings of Archaic Materials and Assemblies* is a compilation of fire ratings from earlier sources for a wide variety of materials and assemblies found in buildings from the nineteenth to the mid-twentieth centuries. This guideline also provides methods for calculating the fire resistance of general classes of archaic materials and assemblies for which no documentation can be found.

First published in 1980, this guideline has found widespread use and acceptance among architects, engineers, preservationists, and code officials. It has been incorporated into numerous state and local building codes, three model code publications, and two NFPA standards.

Now, for the Partnership for Advancing Technology in Housing (PATH) program, the *Guideline on Fire Ratings of Archaic Materials and Assemblies* has been updated to reflect changes in assessment techniques and to provide additional information on doors. HUD is pleased to reissue this important and time-tested publication, knowing that it will remain a valuable resource for preserving and reusing our nation's housing and building stock.

Susan M. Wachter
Assistant Secretary for Policy Development and Research

Acknowledgments

The National Institute of Building Sciences produced the first edition of the *Guideline on Fire Ratings of Archaic Materials and Assemblies* in 1980, with Brady Williamson the principal author and Joseph Zicherman, Fred Fisher, and Harry Hasegawa coauthors. Reviewers were Herman Spaeth, Anne Watson, Vytenis Babrauskas, Norman Kornsand, Harold Nelson, Richard Bletzacker, and Russell Parks. Project managers were Robert Kapsch of HUD and William Brenner of NIBS. Technical managers were David Hattis and Howard Markman of Building Technology, Inc.

NIBS produced this updated edition in 1999, with Joseph Zicherman the principal consultant. Reviewers were Jack Watts, Caroline Alderson, Paul Armstrong, and Harold Olin. Project managers were Nelson Carbonell of HUD and William Brenner of NIBS. The technical manager was David Hattis of Building Technology, Inc., and the graphic designer was Marcia Axtmann Smith. NFPA provided an electronic version of the tables and illustrations in Appendix A. The material in Appendix B is used with the permission of English Heritage.

Table of Contents

Forewordiii
Acknowledgments	v
Introduction	1
1—Fire-Related Performance of Archaic Materials and Assemblies	1
1.1. Fire Performance Measures	1
<i>Figure I. Tunnel Test Results for Eight Species of Lumber</i>	<i>3</i>
1.2. Combustible Construction Types	3
2—Building Evaluation	4
2.1. Preliminary Evaluation	4
<i>Figure II. Preliminary Evaluation Field Notes</i>	<i>7</i>
<i>Figure III. Preliminary Evaluation Worksheet</i>	<i>9</i>
2.2. Fire Resistance of Existing Building Elements	8
2.3. Effects of Openings and Penetrations in Fire Resistant Assemblies on Fire Endurance and Fire Resistance Ratings	8
3—Final Evaluation and Design Solution	11
3.1. The Experimental Approach	11
3.2. The Theoretical Approach	12
<i>Harmathy's Ten Rules of Fire Endurance Rating</i>	<i>12</i>
<i>Illustration of Harmathy's Rules</i>	<i>15</i>
<i>Figure IV. Diagrammatic Illustration of Harmathy's Ten Rules</i>	<i>16</i>
3.3. “Thickness Design” Strategy	17
3.4. Evaluation of Doors	18
<i>Figure V. Door Modification Details</i>	<i>19</i>
4—Summary	20
4.1. Application for Listed Building Elements	21
4.2. Application for Unlisted Building Elements	21
4.3. General Application	22
Appendix A—Fire Rating Tables	A-1
<i>Detailed Table of Contents for Appendix A</i>	<i>A-1</i>
<i>Figure VI. Sample Fire Rating Table</i>	<i>A-3</i>
Appendix B—Upgrading the Fire Resistance of Wood Panel Doors	B-1
Appendix C—Bibliography	C-1



Guideline on Fire Ratings of Archaic Materials and Assemblies

Introduction

The purpose of the *Guideline on Fire Ratings of Archaic Materials and Assemblies* is to assist architects, engineers, preservationists, and code officials in evaluating the fire safety of older buildings by providing documentation on the fire-related performance of a wide variety of archaic building materials and assemblies, and, for those cases where documentation cannot be found, by providing ways to evaluate general classes of archaic materials and assemblies. The term "archaic" encompasses materials and assemblies typical of an earlier time and no longer in common use. "Fire-related performance" includes fire resistance, flame spread, smoke production, and combustibility.¹

The Guideline assumes that the building elements being evaluated—as well as their fastening, joining, and incorporation into the building structure—are mechanically sound. The user must make a determination that the original materials and the manner in which they were installed are in good condition and have not been

weakened by age or deterioration. Such an assessment may be difficult because process and quality control were not good in many industries and variations among locally available raw materials and manufacturing techniques often resulted in products or installations that varied considerably in strength and durability. The properties of iron and steel, for example, exhibited great variation depending on the mill and the process used.

With this caveat, there is nothing inherently inferior about archaic materials or construction techniques. The pressures that promote changes in construction are most often economic and technological—matters not necessarily related to safety. The high cost of labor made wood lath and plaster uneconomical. The high cost of land and the congestion of cities provided the impetus for high-rise construction, and improved technology made it possible. The difficulty with archaic materials and assemblies is not a question of suitability, but familiarity, and the question of their continued use is usually not based on their fire performance but on the lack of sufficient documentation related to that performance. Lacking documentation, the building official may require a full-scale fire test or the removal of the construction in question. Both alternatives are time consuming, wasteful, and destructive of the historic fabric of the building.

Modern building codes state the fire performance of key building elements—such as walls, floor/ceiling assemblies, doors, and shaft enclosure—in performance terms, as **hours of fire resistance**. It does not matter whether these elements were built in 1850 or 2000, only that they provide the degree of fire resistance required by local building regulations. This Guideline is intended to provide a basis for the continued acceptance of archaic materials and assemblies that otherwise meet modern fire performance requirements.

1 Fire-Related Performance of Archaic Materials and Assemblies

1.1 Fire Performance Measures

This Guideline does not specify the levels of fire performance required for building components. These are controlled by the building's occupancy and use as set forth in local building regulations, which require specific building components or assemblies such as walls, floor/ceilings, and doors to be

¹ For information on other fire-related aspects of older buildings, see the *Preservation Briefs* and *Preservation Tech Notes* series published by the Preservation Assistance Division, National Park Service, U.S. Department of Interior. These publications are available online at www2.cr.nps.gov/tps.

characterized in terms of "fire resistance" and require exposed materials to be characterized in terms of "flame spread."

Fire resistance and flame spread are fundamentally different parameters, affecting life and property safety in different ways. Fire resistance relates to **structural fire performance** and becomes important only after a fire has become established and threatens a building's structural integrity. Flame spread relates to the **potential for fire growth** within a structure. Properties related to flame spread are most important in the early stages of a fire and usually measure the performance of exposed or "finish" materials within building spaces.

For archaic materials, flame spread properties, unlike fire resistance properties, generally can be deduced through the examination of materials, through testing according to ASTM E 84, or other methods. Published data for the flame spread properties of specific assemblies is limited, however, except for recent products listed in handbooks.

The mitigation or treatment of potential problems related to flame spread (for example, the removal of suspect or defective finish materials, or their treatment with an appropriate coating or low flame spread finish) will generally cost less than the treatment of fire resistance deficiencies since the latter may affect large numbers of door assemblies or entire building structural systems.

The fire resistance of a given building element is established by subjecting a sample of the assembly to a "standard" fire test to determine its fire resistance. This is essentially its resistance to destruction (i.e., specified loss of function) throughout a prescribed time period in a fully developed fire. The test follows a "standard" time-temperature curve derived from a methodology that has changed little since the 1920s. The fire resistance test results tabulated in Appendix A have been reviewed and conservatively adjusted to reflect criteria found in the currently accepted versions of consensus-based standard fire resistance test methods.

Flame spread and smoke production, not always tested for in earlier years, are measured according to the ASTM E 84 test method. Archaic materials evaluated for these properties generally can be assumed to fall within a well-known range of values because the principal combustible component of these materials is cellulose. Smoke production, expressed as smoke density, continues to be important today. Early flame spread tests, developed in the 1940s, included a test for smoke density (104).

Plastics, one of the most important classes of contemporary materials, were not found in the review of archaic materials. If plastics are to be used in a rehabilitated building, they should be evaluated by contemporary standards. Information and documentation of their fire-related

properties and performance is widely available.

Flame spread and smoke density are discussed below. Test results for eight common species of lumber, published in an Underwriter's Laboratories' report of 1952 (104), are reproduced in Figure 1. Similar data can also be found in the USDA Forest Service, *Wood Handbook (Agriculture Handbook 72)*, available online at www.fs.fed.us.

Flame Spread

For regulatory purposes, the flame spread of interior finishes is most often measured using the ASTM E 84 "tunnel test." This test measures how far and how fast flames spread across the surface of the test sample.² The resulting flame spread rating (FSR) is expressed as a number on a continuous scale where cement-asbestos board is 0 and red oak is 100 (materials with a flame spread greater than red oak have a FSR greater than 100.) The scale is divided into distinct groups or classes. The most commonly used flame spread classifications are:

² Other accepted standard test methods for assessing fire growth characteristics related to flame spread of finish materials include room fire tests. These may be useful for conducting evaluations of finish materials under the alternative materials and methods provisions of adopted codes in lieu of providing tunnel test data. Such test methods are typified by ASTM E 603, *Standard Guide for Room Fire Experiments*, as well as NFPA 265 and UBC Standard 8-2, both of which provide a "Test Method for Evaluating Room Fire Growth Contribution of Textile Wall Covering."

<i>Species of Lumber</i>	<i>Flame Spread</i>	<i>Smoke Density</i>
Western White Pine	75	50
Northern White Pine	120–215	60–65
Ponderosa Pine	80–215	100–110
Yellow Pine	180–190	275–305
Red Gum	140–155	40–60
Yellow Birch	105–110	45–65
Douglas Fir	65–1000	10–100
Western Hemlock	60–75	40–120

Figure I. Tunnel Test Results for Eight Species of Lumber

- Class I or A, with a 0–25 FSR
- Class II or B, with a 26–75 FSR
- Class III or C, with a 76–200 FSR

These classifications are typically used in modern building codes to restrict the rate of early fire spread on material surfaces. Since they differ, not all classes of materials can be used in all places throughout a building. For example, the flame spread of interior finishes in vertical exit ways or corridors leading to exits is more strictly regulated than are finishes in private dwelling units.

In general, inorganic archaic materials such as brick and tile can be expected to be in Class I. Materials of whole wood are mostly Class II or the lower end of Class III, although the thickness of specific products is important. For example, thin plywood or wood-grained particle board panels reconstituted from whole wood and based on a given wood species will generally

have higher flame spread properties than those based on the original wood species tested as a thicker specimen. This effect needs to be considered in making design decisions.

Whole wood is defined as wood used in the same form as sawn from the tree. This is in contrast to contemporary reconstituted wood products such as plywood, fiberboard, hardboard, particle board, and oriented-strand board (OSB). If a combustible archaic material such as a non-fire retardant ceiling tile is not fabricated from whole wood, its flame spread classification could be well over 200 and thus would be particularly unsuited for use in exits and other critical locations in a building. Some plywoods and various wood fiberboards have flame spreads over 200. Although they can be treated with fire retardants to reduce their flame spread, it would be advisable to assume that all such products have a flame spread of over 200 unless there is information to the contrary.

Smoke Density

The measurement of the density of smoke produced is specifically part of the ASTM E 84 tunnel test procedure. For the eight species of lumber shown in Figure I, the highest levels are 275–305 for yellow pine, but most of the others are less smoky than red oak, which has an index of 100. With the exception of values observed for some wood composites, the smoke values listed in Figure 1 are well below the general limitation of 450 adopted by most building codes.

1.2 Combustible Construction Types

One of the earliest forms of timber construction used exterior load-bearing masonry walls with masonry columns or timber posts supporting timber beams and floors in the interior of the building. This form of construction, often called "mill" or "heavy timber" construction, displays fire resistance in excess of one hour. The exterior masonry walls will generally contain the fire within the building.

With the development of dimensional lumber, there was a switch from heavy timber to "balloon frame" construction. The balloon frame uses load-bearing exterior wood-frame walls with long studs that often extend from foundation to roof. When long studs became scarce, another form of construction, the "platform frame," replaced the balloon frame. This occurred

from the 1850s to the 1920s in different areas of the country, depending on the supply of long studs. If information on the initial construction date of a wood-framed building is known, along with information about local practices followed at the time of construction, the likelihood that a building includes balloon framing may be assessed and addressed.

The difference between the two systems is significant because platform framing is automatically fire-blocked at every floor, while balloon framing commonly has concealed spaces that extend unblocked from basement to attic. The architect, engineer, and code official must be alert to the presence of such construction details because of the ease with which fire can spread in concealed building spaces. Requirements for fire blocking and fire stopping and allowances for combustible and noncombustible concealed spaces are set forth in local building regulations.

2

Building Evaluation

A given rehabilitation project will most likely go through several stages. The preliminary evaluation process involves surveying the prospective building, where the flame spread performance and fire resistance performance of existing building materials and construction systems are identified and

compared to local code requirements. Potential problems such as performance at levels below local requirements are noted for closer study. The final evaluation phase involves developing solutions to upgrade, where needed, materials and assemblies to the required flame spread and fire resistance performance; preparing working drawings and specifications; and securing necessary code approvals.

2.1

Preliminary Evaluation

The preliminary evaluation should begin with a building survey to note existing materials, the general arrangement of the structure, the use of occupied spaces, and the details of construction. The designer needs to know "what is there" before a decision can be reached about what to keep, what to remove, and what to upgrade during the rehabilitation process.

The evaluation must take into account the former and projected uses of the building and modifications to its mechanical, plumbing, and electrical systems. Seismic events, fires, and other accidents as well as non-conforming alterations must be researched. Finally, archaic materials and assemblies must be evaluated against applicable code requirements.

Two possible sources of information helpful in the preliminary evaluation are the original building plans and the building code in effect at the time of orig-

inal construction. Plans may be on file with the local building department or in the offices of the original designers or their successors. If plans are available, the investigator should verify that the building was constructed according to the plans and whether or not the plans have been modified to include later alterations. Earlier editions of the local building code may be on file in the building department. The code in effect at the time of construction will contain fire performance criteria under which the original building was constructed. While this is no guarantee that the required performance was actually provided, it does give the investigator some guidance as to the level of performance that may be expected. Current code administration procedures and enforcement practices will define whether the requirements of the code in effect at the time of construction complies with currently required levels of performance.

Figure II illustrates one method for organizing preliminary field notes, with space provided for noting the materials, dimensions, and condition of the principal building elements. Each floor of the structure should be visited. In practice, there will often be identical materials and construction on every floor, but any exceptions may be of vital importance. A schematic diagram should be prepared for each floor showing the layout of exits and hallways and indicating where each element described in the field notes fits into the

structure as a whole. The locations of stairways and elevators should be clearly marked on the drawings. All exterior means of escape should be identified.

The exact arrangement of interior walls is of secondary importance from a fire safety point of view and need not be shown on the drawings unless they are required by code.

The following notes explain the entries in Figure II.

■ **Exterior Bearing Walls.** Many old buildings utilize exterior walls to support the floor/ceiling assemblies at the building perimeter. There may be columns or interior bearing walls within the structure, but the exterior walls and their fire resistance are an important factor in assessing the building's fire safety. Note how the floor/ceiling assemblies are supported at their interface with the exterior walls of the building. If columns are incorporated in the exterior walls, the walls may be considered nonbearing.

■ **Exterior Nonbearing Walls.** The fire resistance of exterior walls is an important factor for two reasons. These walls (both bearing and non-bearing) are depended upon to contain a fire within the building of origin, or to keep a fire originating outside of a building from igniting that building either on the exterior or the interior. It is, therefore, important to indicate on the drawings the location and construction of all windows, doors, shutters, and other

openings as well as the thickness and framing of any wired glass. The protection of openings adjacent to and potentially affecting any exterior means of egress, such as exterior stairs and fire escapes, is also important. The ground floor drawing should locate the building on the property and indicate precise distances to adjacent buildings.

■ **Interior Bearing Walls.** It may be difficult to tell whether or not an interior wall is load bearing, but the field investigator should attempt to make this determination. At a later stage of the rehabilitation process, this question will need to be answered exactly. Therefore, the field notes should be as accurate as possible.

■ **Interior Nonbearing Walls (Partitions).** A partition is a "wall that extends from floor to ceiling and subdivides space within any story of a building" (48). Besides providing for general separation of spaces within buildings, partitions also may have fire safety functions that entail specific fire resistance requirements. Examples include party walls, occupancy separations, smoke barriers, and corridor and exit enclosures. These must be clearly identified and may include fire-rated walls that provide the same functions. When such walls enclose a means of egress, the required flame spread properties of finish materials also must be accounted for.

Figure II includes categories for several types of walls. Since under some circumstances a building may have only one type of wall construction and in others it may have several, the occurrence and function of walls must be carefully noted and evaluated.

The field investigator should be alert for differences in function as well as in materials and construction details. In multiunit buildings, for example, wall details within apartments generally are not as important as the functions of separation walls or walls along defined egress paths and stairwells.

The preliminary field investigation should attempt to determine the thickness of all walls. A term introduced below called "thickness design" will depend on an accurate ($\pm 1/4$ inch) determination of thickness. Even though this initial field survey is called "preliminary," the data generated should be as accurate and complete as possible.

The field investigator should note the exact location from which his or her observations are recorded. For instance, if a hole is found through a stairwell wall that allows a cataloguing of the construction details, the field investigation notes should reflect the location of the "find." At the preliminary stage it is not necessary to core walls, since the interior details of construction usually can be determined at some location.

■ **Structural Frame.** There may or may not be a complete skeletal frame, but usually there are columns, beams, trusses, or similar elements. The dimensions and spacing of the structural elements should be measured and indicated on the drawings. For instance, if 10-inch-square columns are located on a 30-foot-square grid throughout the building, this should be noted. The structural material and its protective covering, if any, should be identified wherever possible. The thickness of the cover materials should be determined to an accuracy of $\pm 1/4$ inch. In a case in Chicago, local code officials found that in many older buildings slated for renovation, original wood timber columns had been replaced by nonfire-rated metal columns, degrading the structure's potential fire endurance. The performance of the metal columns was readily upgraded, however, by providing fire resistive cladding to achieve the required hourly fire ratings.

■ **Floor/Ceiling Structural Systems.** A sketch of the cross section of the structural system should be made. If there is no location where accidental damage has opened the floor/ceiling construction to visual inspection, it is necessary to make such an opening. An evaluation of the fire resistance of a floor/ceiling assembly requires detailed knowledge of the materials and their arrangement. Special

attention should be paid to the cover on structural steel elements and the nature and condition of suspended ceilings and similar membranes.

■ **Roofs.** If it is apparent that the roof is sound for ordinary use and can be retained in the rehabilitated building, it then becomes necessary to evaluate its fire performance. The field investigator must measure the thickness and identify the types of materials that have been used. Be aware that there may be several layers of roofing materials present and that the number may be limited by the local building code.

■ **Doors.** Doors to corridors and exits represent some of the most important fire resistive elements within a building. The uses of the spaces separated by the doors largely controls the level of fire performance necessary. Walls and doors enclosing stairs or elevator shafts normally require a higher level of performance than between a bedroom and bath. The various uses are differentiated in Figure II.

Careful measurements of the thickness of door panels must be made and the type of core material within each door must be determined. Note whether doors have self-closing devices and check the general operation of the doors. Latches should engage and doors should fit tightly in the frame. Hinges should be in good condition. Identify any door glazing and note its framing material.

■ **Materials.** The field investigator should be able to identify commonly found building materials in a given geographic area. In situations where an unfamiliar material is found, a sample should be obtained.

■ **Thickness.** The thickness of all materials should be measured accurately since under most circumstances anticipated levels of fire resistance are very sensitive to the material thickness.

■ **Condition.** The method of attaching the various layers and facings to one another or to the supporting structural element should be noted under the appropriate building element. The "secureness" of the attachment and the general condition of the layers and facings also should be noted.

■ **Notes.** The "Notes" column can be used for many purposes, including providing specific references to other field notes or drawings, such as those describing the occupancy of the building or space and the functions of its components.

After the building survey is completed, the data collected must be analyzed. A suggested work sheet for organizing this information is shown in Figure III.

Requirements for fire resistance and the flame spread properties of each building element are normally established by the local building code. The fire performance of the existing materials and assemblies should be estimated using one of the

Preliminary Evaluation Field Notes				
<i>Building Element</i>	<i>Materials</i>	<i>Thickness</i>	<i>Condition</i>	<i>Notes</i>
Exterior bearing walls				
Interior bearing walls				
Exterior nonbearing walls				
Interior nonbearing walls or partitions	A			
	B			
Structural frame:				
Columns				
Beams				
Other				
Floor/ceiling structural system:				
Spanning				
Roofs				
Doors (including frame and hardware):				
Enclosed vertical exitway				
Enclosed horizontal exitway				
Other				

Figure II. Preliminary Evaluation Field Notes

techniques described below. If the fire performance of the existing building element(s) is equal to or greater than that required, the materials and assemblies may be considered acceptable as they are. If the fire performance is less than required, corrective measures must be taken.

The most common methods of upgrading the level of protection are either the removal and replacement of the existing building elements or repairing and upgrading them. Other fire protection measures, such as automatic sprinklers or detection and alarm systems, also can be considered, but they are beyond the scope of this Guideline. If the upgraded protection is still less than that required or deemed to be acceptable, additional corrective measures must be taken. This process must continue until a level of performance acceptable to the building authority and consistent with good practice is achieved.

2.2 Fire Resistance of Existing Building Elements

The ability of the existing building elements to sustain a standard fire test exposure for a prescribed period, generally referred to as its fire endurance or fire resistance, can be estimated from the tables and histograms contained in Appendix A, which is organized by type of building element: walls, columns,

floor/ceiling assemblies, beams, and doors. Within each building element, the tables are organized by type of construction, such as masonry, metal, or wood frame, then further divided by minimum dimensions or the thickness of the building element.

A histogram precedes every table that has ten or more entries. Its X-axis measures fire resistance in hours and its Y-axis shows the number of entries in that table having a given level of fire resistance. The histograms also contain the location of each entry within the table for easy cross referencing.

Because they are keyed to the tables, the histograms usually can be used to speed the preliminary investigation. For example, Table 1.3.2, "Wood Frame Walls 4" to Less Than 6" Thick," contains 96 entries. Rather than study each table entry, the designer can examine the histogram, which shows that every wall assembly listed in that table has a fire resistance of less than two hours. If the building code required the wall to have 2-hour fire resistance, the designer, with a minimum of effort, is made aware of a problem that requires closer study.

Suppose the code had only required a wall of 1-hour fire resistance. The histogram shows far fewer complying elements—19—than noncomplying ones—77. If the existing assembly is not one of the 19 complying entries, there is a strong possibility it is deficient. The histograms also can be used in the converse situ-

ation: if the existing assembly is not one of the smaller number of entries with a lower than required fire resistance, there is a strong possibility the existing assembly will be acceptable.

At some point, the existing building component or assembly must be located within the tables. If not, its fire resistance must be determined through one of the other techniques presented herein. Locating the building component in the tables in Appendix A not only documents the accuracy of its fire resistance rating, but provides a source of that documentation for the building official.

2.3 Effects of Openings and Penetrations in Fire Resistant Assemblies on Fire Endurance and Fire Resistance Ratings

There are often features of wall or floor/ceiling components that were not included in the original building design or that were not included in fire tests, including doors and windows, glazed transoms and other types of glazing in corridors, shaftways, through-penetrations, and membrane penetrations for utilities such as plumbing, electrical, and communications services.

Building codes generally use the terms "openings" and "opening protection" to refer to doors and window openings. Conversely, the term "penetrations" typically

Preliminary Evaluation Worksheet							
<i>Building Element</i>	<i>Required fire resistance</i>	<i>Required flame spread</i>	<i>Estimated fire resistance</i>	<i>Estimated flame spread</i>	<i>Method of upgrading</i>	<i>Est. upgraded protection</i>	<i>Notes</i>
Exterior bearing walls							
Interior bearing walls							
Exterior nonbearing walls							
Interior nonbearing walls or partitions	A						
	B						
Structural frame:							
Columns							
Beams							
Other							
Floor/ceiling structural system:							
Spanning							
Roofs							
Doors (including frame and hardware):							
Enclosed vertical exitway							
Enclosed horizontal exitway							
Other							

Figure III. Preliminary Evaluation Worksheet

refers to passages for mechanical or electrical services for traversing assemblies found in a building. Each requires a different fire resistance test method to be evaluated, and each generates different information.

The most common examples of penetrations are pipes and utility wires passed through holes poked through an assembly. Their performance will have been qualified for use in new buildings by testing according to the ASTM E 814, *Standard Test Method for Fire Tests of Through-Penetration Fire Stops*, and its derivative standards promulgated by ANSI and NFPA. During the life of the building, however, many penetrations may have been added, and by the time a building is ready for rehabilitation it is not sufficient just to consider the fire resistance of the assembly as originally constructed.

It is also necessary to consider all classes of penetrations and openings and their relative impact upon fire performance. For instance, the fire resistance of a corridor wall may be less important in a given building application than the effect of plain glass being present in doors or transoms since the latter will lead to very early failures. Generally speaking, a building's doors and associated installation features (hardware, frames, transoms, and glazing) represent the most important single class of openings having a crucial fire safety function that needs to be addressed.

A fully developed fire generates substantial quantities of heat and gaseous fuels capable of penetrating unprotected openings or non-fire-stopped holes that might be present in the walls or floors and ceilings of a fire-affected compartment. The presence of such unprotected openings and penetrations can lead to a severe degradation of the fire resistance of those building elements and to a greater potential for fire spread. This is particularly true for penetrations located high in a compartment where the positive pressure of the fire can force unburned gases through such a penetration.

Unprotected penetrations in a floor/ceiling assembly will generally completely negate the barrier qualities of the assembly and will lead to rapid spread of fire to the space above. It will not be a problem, however, if the penetrations are filled with noncombustible or other fire-rated materials adequately attached to the structure. The threat to the upper two-thirds of walls exposed to fire will be similar to that experienced by the floor/ceiling assemblies undergoing a fire exposure from below. This is because a positive pressure can be reasonably expected to be present in the top of any room exposed to a fully developed fire, and such an exposure can be expected to push hot and burning gases through any penetrations present unless they are completely sealed. In the same context, the performance of all components related to HVAC systems pre-

sent in buildings (as well as mechanical or electrical/communication systems whose components are associated with fire resistive assemblies or components) must be carefully considered. Materials available to mitigate these potential problems include listed intumescent and other insulating firestopping materials, systems, and assemblies as found in listing handbooks from approved third party laboratories.

Building codes require doors installed in fire resistive walls to resist the passage of fire for a specified period of time. If the door to a room with a fully developed fire is not closed, a large plume of fire will typically escape through the doorway, preventing anyone from using the space outside the door while allowing the fire to spread. This is why the presence of effective door closers and an absence of obstacles to the timely closing of fire doors in an emergency are so important.

Glass in doors and transoms can be expected to shatter rapidly unless constructed of listed or approved wired glass in a steel frame or other contemporary fire-rated glazing products now available. As with other building elements, non-firestopped penetrations or nonrated openings including those created by windows and transoms must be upgraded or otherwise protected.

As part of ongoing rehabilitation efforts in older buildings, significant research directed at upgrading the fire resistance of

existing door, transom, and side-light assemblies has taken place in the United States and Great Britain. An English Heritage Technical Guidance Note on this subject (166) treats this problem comprehensively and includes information for upgrading wood panel doors. Because the fire test protocols utilized in Britain for doors are based on British Standard 476, which provides an equivalent fire exposure to similar U.S. test methods, the results presented in the English Heritage Technical Guidance Note can be used directly in American applications.

In the United States, efforts to upgrade door performance have been underway under the auspices of the General Services Administration as part of an effort to preserve the historic components of its older structures. This has resulted in the successful fire testing of retrofitted door assemblies using contemporary glazing products and associated materials.

Table 5.1 in Appendix A contains 42 entries describing the fire endurance of doors mounted in sound, tight-fitting frames. Appendix B contains 28 treatments for upgrading the fire resistance of wood panel doors from the above-mentioned English Heritage Technical Guidance Note. Section 3.4, below, outlines one procedure for the evaluation and possible upgrading of existing doors.

3 Final Evaluation and Design Solution

The final building evaluation begins after the rehabilitation project has reached the final design stage and the choice has been made to retain certain archaic materials and assemblies. By this point, the specific fire resistance and flame spread requirements will have been determined for the project. This may involve having the local building and fire officials review the field drawings and evaluations recorded in the worksheets in Figures II and III.

If the materials and assemblies in question are listed in Appendixes A or B, their fire resistance can be determined immediately. If not, two other approaches can be used, one experimental, the other theoretical.

3.1 The Experimental Approach

This approach involves conducting an appropriate fire test(s) to determine directly the material or assembly's fire-related properties. Such testing must utilize ASTM E 84, *Test Method for Surface Burning Characteristics of Building Materials* (flame spread), and ASTM E 119, *Test Methods for Fire Tests of Building Construction and Materials* (fire resistance). Both test methods require significant amounts of sample for testing

so other approaches, as outlined later, should also be investigated. There are a number of laboratories in the United States that routinely conduct such fire tests; a current list can be obtained by contacting one of the model code organizations or the National Fire Protection Association.

A contract with a testing laboratory for a specific project should require the laboratory's observation (or that of a registered engineer acceptable to the building official) of the specimen's preparation and testing. A complete description of where and how the specimen was obtained from the building, the transportation of the specimen, and its preparation for testing should be noted in detail so that the building official can be satisfied that the fire test is representative of the actual use. Photographic or video documentation are especially helpful in this regard.

The test report should describe the fire test procedure and the response of the material or assembly. The laboratory usually submits a cover letter with the report to describe the provisions of the fire test that were satisfied by the material or assembly under investigation. The building official generally will require such a cover letter but will also read the report to confirm that the material or assembly meets code requirements. Local code officials should be kept informed of all details of the testing process.

The experimental approach can

be costly and time consuming because specimens must be taken from the building and transported to the testing laboratory. For testing of flame spread of finish materials by ASTM E 84, testing will require a sample two feet wide and 25 feet long, which may be taken in three sections. For testing by ASTM E 119 of a load-bearing assembly that has continuous reinforcement, the test specimen must be removed from the building, transported, and tested in one piece.

In special cases, a "nonstandard" small-scale test may be used with the concurrence of the building official for fire endurance testing. Sample sizes need only be 10 to 25 square feet, while full-scale tests require test samples of either 100 or 180 square feet in size. The small-scale test is best suited for testing non-load bearing assemblies against thermal transmission only.

For alternates to flame spread testing according to ASTM E 84, consider the methods described in the next section.

3.2

The Theoretical Approach

Theoretical methods offer an alternative to the full-scale fire tests discussed above. For example, most codes allow alternate materials and methods to be used based on test data and engineering analyses in lieu of full-scale tests. These analyses may draw upon computer simu-

lation and mathematical modeling, thermodynamics, heat-flow analysis, and materials science to predict the fire performance of a material or assembly.

Where properties other than fire endurance are concerned, the evaluation of materials for heat release through the use of cone calorimeter techniques (see ASTM E 1354) or through use of the intermediate scale calorimeter "ICAL" (see ASTM E 1623) may be appropriate. Such an evaluation can be included as one component of a fire hazard analysis conducted for review by the code official for a given project design. The evaluation of flame spread by the LIFT (linear ignition and flame travel) apparatus (see ASTM E 1321) or room fire testing of unusual or poorly characterized finish materials based on the techniques found in ASTM E 603, cited earlier, also may be of use.

One theoretical method is the "Ten Rules of Fire Endurance Rating," published by T. Z. Harmathy in the May 1965 edition of *Fire Technology* (35). Harmathy's Rules provide a foundation for extending the data in Appendix A.

Harmathy's Ten Rules of Fire Endurance Rating

Rule 1: The "thermal" fire endurance³ of a construction consisting of a number of parallel layers is greater than the sum of each "thermal" fire endurance that is characteristic

of the individual layers when exposed separately to fire.

The minimum performance of an untested assembly can be estimated if the fire endurance of the individual components is known. Though the exact rating of the assembly cannot be stated, the endurance of the assembly is greater than the sum of the endurance of the components. This rule can be exemplified by the fact that the fire endurance of multiple sheets of gypsum wallboard, such as those of other fire-rated materials, will exceed the fire endurance of individual fire-rated slabs of the same total thickness.

When a building assembly or component is found to be deficient, the fire endurance can be upgraded by providing a protective membrane. This membrane could be a new layer of brick, plaster, or drywall. The fire endurance of this membrane is called the "finish rating." Tables 1.5.1 and 1.5.2 in Appendix A contain the finish ratings for the most commonly employed materials (see also the notes to Rule 2).

The test criteria for the finish rating is the same as for the thermal fire endurance of the total assembly: average temperature increases of 250°F above

³ The "thermal" fire endurance is the time at which the average temperature on the unexposed side of a construction exceeds its initial value by 250°F when the other side is exposed to the "standard" fire specified by ASTM Test Method E 119.

ambient or 325°F above ambient at any one place with the membrane being exposed to the fire. The temperature is measured at the interface of the assembly and the protective membrane.

Rule 2: The fire endurance of a construction does not decrease with the addition of further layers.

Harmathy notes that this rule is a consequence of the previous rule. Its validity follows from the fact that the additional layers increase both the resistance to heat flow and the heat capacity of the construction. This, in turn, reduces the rate of temperature rise at the unexposed surface.

This rule is not just restricted to "thermal" performance but affects the other fire test criteria: direct flame passage, cotton waste ignition, and load bearing performance. This means that certain restrictions must be imposed on the materials to be added and on the loading conditions. One restriction is that a new layer, if applied to the exposed surface, must not produce additional thermal stresses in the construction, i.e., its thermal expansion characteristics must be similar to those of the adjacent layer. Each new layer must also be capable of contributing enough additional strength to the assembly to sustain the added dead load. If this requirement is not fulfilled, the allowable live load must be reduced by an amount equal to the weight of the new layer. Because of these limitations, this

rule should not be applied without careful consideration.

Particular care must be taken if the material added is a good thermal insulator. Properly located, the added insulation could improve the "thermal" performance of the assembly. Improperly located, the insulation could block necessary thermal transmission through the assembly, thereby subjecting the structural elements to greater temperatures for longer periods of time, and could cause premature structural failure of the supporting members.

Under this rule, the addition of new components, such as EIFS systems, must be evaluated with care where they can affect fire performance.

Rule 3: The fire endurance of constructions containing continuous air gaps or cavities is greater than the fire endurance of similar constructions of the same weight, but containing no air gaps or cavities.

Voids in a construction provide additional resistance in the path of heat flow. Numerical heat flow analyses indicate that a 10 to 15 percent increase in fire endurance can be achieved by creating an air gap at the mid-plane of a brick wall. Since the gross volume is also increased by the presence of voids, the air gaps and cavities have a beneficial effect on stability as well. However, constructions containing combustible materials within an air gap may be regarded as

exceptions to this rule because of the possible development of burning in the gap.

There are numerous examples of this rule in the tables. For instance:

Table 1.1.4; Item W-8-M-82: Cored concrete masonry, nominal 8-inch thick wall with one unit in wall thickness and with 62% minimum of solid material in each unit, load bearing (80 psi). Fire endurance: 2 1/2 hours.

Table 1.1.5; Item W-10-M-11: Cored concrete masonry, nominal 10-inch thick wall with two units in wall thickness and a 2-inch air space, load bearing (80 psi). The units are essentially the same as item W-8-M-82. Fire endurance: 3 1/2 hours.

These walls show 1-hour greater fire endurance by the addition of the 2-inch air space.

Rule 4: The farther an air gap or cavity is located from the exposed surface, the more beneficial is its effect on the fire endurance.

Radiation dominates the heat transfer across an air gap or cavity and it is markedly higher where the temperature is higher. The air gap or cavity is thus a poor insulator if it is located in a region that attains high temperatures during fire exposure.

Some of the clay tile designs take advantage of these factors. The double cell design, for instance, insures that there is a cavity near the unexposed face. Some floor/ceiling assemblies have air gaps or cavities near the top sur-

face and these enhance their thermal performance.

Rule 5: The fire endurance of a construction cannot be increased by increasing the thickness of a completely enclosed air layer.

Harmathy notes that there is evidence that if the thickness of the air layer is larger than about 1/2 inch, the heat transfer through the air layer depends only on the temperature of the bounding surfaces, and is practically independent of the distance between them. This rule is not applicable if the air layer is not completely enclosed, i.e., if there is a possibility of fresh air entering the gap at an appreciable rate.

Rule 6: Layers of materials of low thermal conductivity are better utilized on that side of the construction on which fire is more likely to happen.

As in Rule 4, the reason lies in the heat transfer process, though the conductivity of the solid is much less dependent on the ambient temperature of the materials. The low thermal conductor creates a substantial temperature differential to be established across its thickness under transient heat flow conditions. This rule may not be applicable to materials undergoing physical-chemical changes accompanied by significant heat absorption or heat evolution.

Rule 7: The fire endurance of asymmetrical construction—constructions that are not identical on both sides of their central line—depends on the direction of heat flow.

This rule is a consequence of Rules 4 and 6 as well as other factors. This rule is useful in determining the relative protection of corridors and stairwells from the surrounding spaces. In addition, there are often situations where a fire is more likely, or potentially more severe, from one side or the other.

Rule 8: The presence of moisture, if it does not result in explosive spalling, increases the fire endurance.

The flow of heat into an assembly is greatly hindered by the release and evaporation of the moisture found within cementitious materials such as gypsum, Portland cement, or magnesium oxychloride. Harmathy has shown that the gain in fire endurance may be as high as 8 percent for each percent (by volume) of moisture in the construction. It is the moisture chemically bound within the construction material at the time of manufacture or processing that leads to increased fire endurance. There is no direct relationship between the relative humidity of the air in the pores of the material and the increase in fire endurance.

Under certain conditions there may be explosive spalling of low permeability cementitious

materials such as dense concrete. In general, one can assume that extremely old concrete has developed enough minor cracking that this factor should not be significant.

Rule 9: Load-supporting elements, such as beams, girders and joists, yield higher fire endurance when subjected to fire endurance tests as parts of floor, roof, or ceiling assemblies than they would when tested separately.

One of the fire endurance test criteria is the ability of a load-supporting element to carry its intended live and dead load. The element will be deemed to have failed when the load can no longer be supported.

Failure usually results for two reasons. Some materials, particularly steel and other metals, lose much of their structural strength at elevated temperatures. Physical deflection of the supporting element, due to decreased strength or thermal expansion, causes a redistribution of the load forces and stresses throughout the element. Structural failure often results because the supporting element is not designed to carry the redistributed load.

Roof, floor, and ceiling assemblies may have primary (e.g., beams) and secondary (e.g., floor joists) structural members. Since the primary load-supporting elements span the largest distances, their deflection becomes significant at a stage when the strength

of the secondary members (including the roof or floor surface) is hardly affected by the heat. As the secondary members follow the deflection of the primary load-supporting element, an increasingly larger portion of the load is transferred to the secondary members.

When load-supporting elements are tested separately, the imposed load is constant and equal to the design load throughout the test. By definition, no distribution of the load is possible because the element is being tested by itself. Without any other structural members to which the load could be transferred, the individual elements cannot yield a higher fire endurance than they do when tested as parts of a floor, roof or ceiling assembly.

Rule 10: The load-supporting elements (beams, girders, joists, etc.) of a floor, roof, or ceiling assembly can be replaced by such other load-supporting elements that, when tested separately, yielded fire endurances not less than that of the assembly.

This rule depends on Rule 9 for its validity. A beam or girder, if capable of yielding a certain performance when tested separately, will yield an equally good or better performance when it forms a part of a floor, roof, or ceiling assembly. It must be emphasized that the supporting element of one assembly must not be replaced by the supporting element of another assembly if

the performance of this latter element is not known from a separate (beam) test. Because of the load-reducing effect of the secondary elements that results from a test performed on an assembly, the performance of the supporting element alone cannot be evaluated by simple arithmetic. This rule also indicates the advantage of performing separate fire tests on primary load-supporting elements.

Illustration of Harmathy's Rules

Harmathy provided one schematic figure that illustrated his Rules.⁴ It should be useful as a quick reference to assist in applying his Rules. (See Figure IV.)

Example Application of Harmathy's Rules

The following examples, based in whole or in part upon those presented in Harmathy's paper (35), show how the Rules can be applied to practical cases.

Example 1

Problem

A contractor would like to keep a partition that consists of a 3 3/4 inch thick layer of red clay brick, a 1 1/4 inch thick layer of plywood, and a 3/8-inch thick layer of gypsum wallboard, at a location where 2-hour fire endurance is required.

⁴ Reproduced from the May 1965 *Fire Technology* (vol. 1, no. 2). Copyright National Fire Protection Association, Boston. Reproduced by Permission.

Is this assembly capable of providing a 2-hour protection?

Solution

- (1) This partition does not appear in the tables in Appendix A.
- (2) Bricks of this thickness yield fire endurances of approximately 75 minutes (Table 1.1.2, Item W-4-M-2).
- (3) The 1 1/4 inch thick plywood has a finish rating of 30 minutes.
- (4) The 3/8-inch gypsum wallboard has a finish rating of 10 minutes.
- (5) Using the recommended values from the tables and applying Rule 1, the fire endurance (FI) of the assembly is larger than the sum of the individual layers, or

$$FI > 75 + 30 + 10 = 115 \text{ minutes}$$

Discussion

This example illustrates how the tables in Appendix A can be utilized to determine the fire resistance of assemblies not explicitly listed.

Example 2

Problem

- (1) A number of buildings to be rehabilitated have the same type of roof slab that is supported with different structural elements.
- (2) The designer and contractor would like to determine whether or not this roof slab is capable of yielding a 2-hour fire endurance. According to a rigorous interpretation of ASTM E 119, however, only the roof assembly, including the roof slab as well as the cover and the supporting elements, can be subjected to a fire test. Therefore, a fire endurance classification cannot be issued for the slabs separately.
- (3) The designer and contractor believe this slab will yield a 2-hour

fire endurance even without the cover, and any beam of at least 2-hour fire endurance will provide satisfactory support. Is it possible to obtain a classification for the slab separately?

Solution

(1) The answer to the question is yes.

(2) According to Rule 10, it is not contrary to common sense to test and classify roofs and supporting elements separately. Furthermore, according to Rule 2, if the roof slabs actually yield a 2-hour fire endurance, the endurance of an assembly,

including the slabs, cannot be less than 2 hours.

(3) The recommended procedure would be to review the tables to see if the slab appears as part of any tested roof or floor/ceiling assembly. The supporting system can be regarded as separate from the slab specimen, and the fire endurance of the assembly listed in the table is at least the fire endurance of the slab. There would have to be an adjustment for the weight of the roof cover in the allowable load if the test specimen did not contain a cover.

(4) The supporting structure or element would have to have at least a 2-hour fire endurance when tested separately.

Discussion

If the tables did not include tests on assemblies that contained the slab, one procedure would be to assemble the roof slabs on any convenient supporting system (not regarded as part of the specimen) and to subject them to a load that, besides the usually required superimposed load, includes some allowances for the weight of the cover.

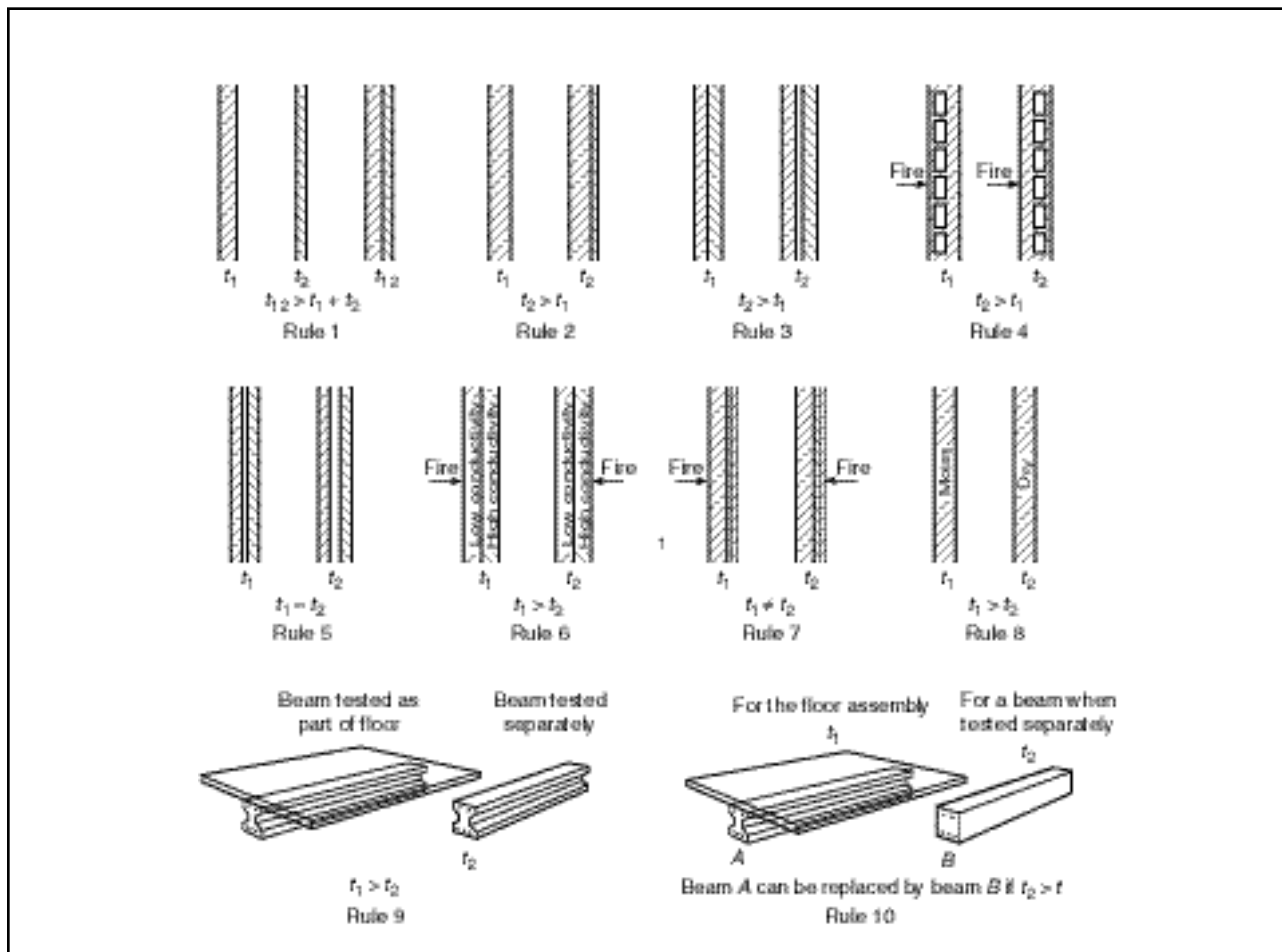

Figure IV. Diagrammatic Illustration of Harmathy's Ten Rules t = fire endurance

Example 3*Problem*

A steel joist floor/ceiling assembly is known to have yielded a fire endurance of 1 hour and 35 minutes. At a certain location, a 2-hour endurance is required. What is the most economical way of increasing the fire endurance by at least 25 minutes?

Solution

(1) The most effective technique would be to increase the ceiling plaster thickness. Existing coats of paint would have to be removed and the surface properly prepared before the new plaster could be applied. Other materials (e.g., gypsum wallboard) could also be considered.

(2) There may be other techniques based on other principles, but an examination of the drawings would be necessary.

Discussion

(1) The additional plaster has at least three effects:

a) The layer of plaster is increased and thus there is a gain of fire endurance (Rule 1).

b) There is a gain due to shifting the air gap farther from the exposed surface (Rule 4).

c) There is more moisture in the path of heat flow to the structural elements (Rules 7 and 8).

(2) The increase in fire endurance would be at least as large as that of the finish rating for the added thickness of plaster. The combined effects in (1) above would further increase this by a factor of 2 or more, depending upon the geometry of the assembly.

Example 4*Problem*

The fire endurance of item W-10-M-1 in Table 1.1.5 is 4 hours. This wall consists of two 3 3/4 inch thick layers of structural tiles separated by a 2-inch air gap and 3/4-inch Portland cement plaster or stucco on both sides. If the actual wall in the building is identical to item W-10-M-1 except that it has a 4-inch air gap, can the fire endurance be estimated at 5 hours?

Solution

The answer to the question is no for the reasons contained in Rule 5.

Example 5*Problem*

In order to increase the insulating value of its precast roof slabs, a company has decided to use two layers of different concretes. The lower layer of the slabs, where the strength of the concrete is immaterial (all the tensile load is carried by the steel reinforcement), would be made with a concrete of low strength but good insulating value. The upper layer, where the concrete is supposed to carry the compressive load, would remain the original high strength, high thermal conductivity concrete. How will the fire endurance of the slabs be affected by the change?

Solution

The effect on the thermal fire endurance is beneficial:

(1) The total resistance to heat flow of the new slabs has been increased due to the replacement of a layer of high thermal conductivity by one of low conductivity.

(2) The layer of low conductivity is on the side more likely to be

exposed to fire, where it is more effectively utilized according to Rule 6. The layer of low thermal conductivity also provides better protection for the steel reinforcement, thereby extending the time before reaching the temperature at which the creep of steel becomes significant.

3.3 "Thickness Design" Strategy

The "thickness design" strategy is based upon Harmathy's Rules 1 and 2. This design approach can be used when the construction materials have been identified and measured, but the specific assembly cannot be located within the tables. The tables should be surveyed again for thinner walls of like material and construction detail that have yielded the desired or greater fire endurance. If such an assembly can be found, then the thicker walls in the building have more than enough fire resistance. The thickness of the walls thus becomes the principal concern.

This approach can also be used for floor/ceiling assemblies provided the assembly will support the loading required for fire endurance testing of the subject assembly. However, the thickness of the cover⁵ and the slab will become a central concern. The fire resistance of the untested assembly will be at least the

⁵ Cover: the protective layer or membrane of material that slows the flow of heat to the structural elements.

fire resistance of an assembly listed in the table having a similar design but with less cover or thinner slabs. For other structural elements (e.g., beams and columns), the element listed in the table must also be of a similar design but with less cover thickness.

3.4 Evaluation of Doors

A separate section on doors is included in this Guideline because the process for evaluation presented below differs from those suggested previously for other building elements. The impact of unprotected openings or penetrations in fire-resistant assemblies has been discussed in Section 2.3 and the importance of door performance on life safety has been stressed. Consistent with this, it is sufficient to note here that improperly or inadequately protected door openings will likely lead to failure of the wall in which they are installed under actual fire conditions.

In all cases, local code requirements for opening protection should be carefully evaluated since many (but not all) 1-hour wall assemblies, for example, require only 20-minute-rated doors to be used. Thus, use of a 1-hour rated fire door assembly under such conditions would present an unwarranted economic hardship.

For other types of building elements (e.g., beams, columns), the tables in Appendix A can be used to establish a minimum level of fire performance, eliminating the need for a fire test. For doors, however, this cannot be done. The data contained in Appendix A, "Table 5.1, Resistance of Doors to Fire Exposure," and Appendix B, "Upgrading the Fire Resistance of Wood Panel Doors," only can provide guidance as to whether a successful fire test is even feasible.

For example, a door required to have 1-hour fire resistance is noted in the tables as providing only 5 minutes. The likelihood of achieving the required 1 hour, even if the door is upgraded, is remote. The ultimate need for replacement of the doors is reasonably clear, and the expense and time needed for testing can be saved. However, if the performance documented in the table is near or in excess of what is being required, then a fire test should be conducted. The test documentation can then be used as evidence of compliance with the required level of performance.

The table entries cannot be used as the sole proof of performance of the door in question because there are other variables that could measurably affect fire performance. The wood may have become embrittled over the years, or multiple coats of flammable varnish could have been added. Minor deviations in the internal construction of a door can also result in significant differences in performance. Methods of securing inserts in panel doors can vary. The major non-destructive

method of analysis, an x-ray, often cannot provide the necessary detail. It is for these, and similar reasons, that a fire test may still be necessary.

It is often possible to upgrade the fire performance of an existing door. Existing and modified doors can be evaluated side-by-side in a single series of fire tests, where the failure of the unmodified door is expected. Because doors upgraded after an initial failure must be tested again, the side-by-side approach can save time and money.

The most common ways that the fire resistance of door assemblies is reduced are: the presence of ventilating elements, including transoms; the presence of plain, non-fire-resistant glass; insufficient thickness or poor condition of plywood door panels and panel inserts; and the improper fit of a door in its frame.

Approaches to solving these problems, as shown in Figure V and Appendix B, are as follows:

- Permanently sealing ventilating elements, such as transoms or ventilation openings in doors, and upgrading their fire resistance to match that of their door assemblies, unless they can be made to close automatically when a fire threat is present. Note that the health and comfort consequences of sealing ventilating elements must be thoroughly evaluated before such work is performed.

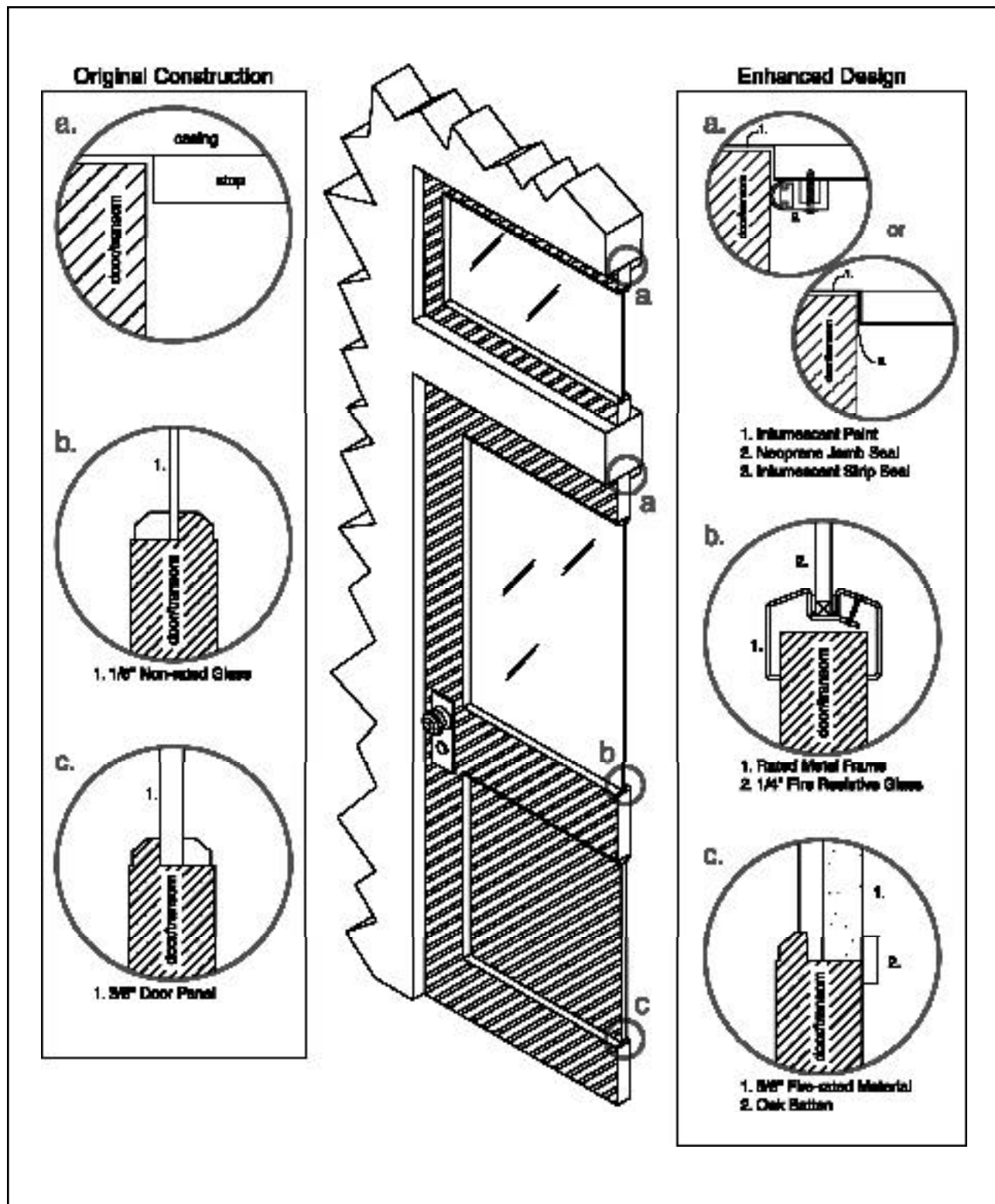

Figure V. Door Modification Details

- Replacing plain glass in doors, transoms and sidelights with approved or listed wired glass or a contemporary fire-resistant glazing product installed in an approved steel or wood frame (167).
- Upgrading panel inserts either by replacing existing panel materials with materials of greater fire resistance (such as swapping an existing wood panel for a grain-printed or -painted inorganic product with the required fire resistance), using intumescent materials, or adding additional layers of material, such as gypsum wallboard, to the existing panel to enhance fire resistance.

Problems related to the improper fit of doors in their frames can be significant because a fire-affected room may develop substantial positive pressure, causing flames, smoke, and hot gases to work their way through otherwise innocent-looking gaps between the door and frame. To mitigate these hazards, listed intumescent paint or gasketing may be applied to the edges of the door or door frame. These expand when exposed to fire, forming an effective fire-resistant seal at the door edges. The use of intumescent materials is widely accepted in fire door construction and fire door frame designs in the United States and Europe.

Because the interior construction of a door cannot be determined by a visual inspection, there is no absolute guarantee that the remaining doors are identical to the one(s) tested. But the same is true for doors constructed today, and reason and judgment must be applied. Doors that appear identical upon visual inspection can be weighed. If their weights are reasonably close, they can be assumed to be identical and to provide the same level of fire performance. Another approach is to fire test more than one door or to dismantle doors selected at random to determine if they have been constructed in the same manner. Original building plans showing door details or other records showing that doors were purchased at one time or obtained from a single supplier can also be evidence of similar construction.

More often though, it is what is visible to the eye that is most significant. The investigator should carefully check the condition and fit of the door and frame and look for frames out of plumb or separating from the wall. Door closers, latches, and hinges must be examined to see that they function properly and are tightly secured. If these are in order and the door and frame have passed a full-scale test, there can be a reasonable basis for allowing the existing doors to remain. However, the importance of insuring satisfactory performance of door hardware cannot be overstated. Full-scale tests of door assemblies in

which sufficient construction materials are present to provide needed fire endurance but that fail because of untimely door opening are well known to fire testing laboratories and engineers. See Figure V.

4 Summary

This section summarizes the various approaches and design solutions for fire resistance discussed in the preceding sections of the Guideline. The term "structural system" includes: frames, beams, columns, and other structural elements. "Cover" is a protective layer of materials or membrane that slows the flow of heat to the structural elements. It cannot be stressed too strongly that the fire endurance of actual building elements can be greatly reduced or totally negated by removing part of the cover to allow pipes, ducts, or conduits to pass through the element. This must be repaired in the rehabilitation process.

The following approaches shall be considered equivalent:

4.1 Application for Listed Building Elements

The fire resistance of a building element can be established from the tables in Appendix A.

This is subject to the following limitations:

- The building elements in the rehabilitated building are constructed of the same materials with the same nominal dimensions as stated in the tables.
- All penetrations in the building element or its cover for services such as electricity, plumbing, and HVAC are treated in a manner consistent with current practices for new construction, using methods tested and documented for their fire endurance and anticipated durability. Descriptions of many such products and methods are available in fire resistance reference handbooks.
- The effects of age and deterioration are repaired so that the building element is sound and the original thickness of all components, particularly covers and floor slabs, is maintained.

This approach essentially follows the approach taken by the model codes, where a material or assembly must be listed in an acceptable publication for a given fire resistance rating to be recognized and accepted.

4.2 Application for Unlisted Building Elements

The fire resistance of a building element that does not explicitly appear in the tables in Appendix A can be established if one or more elements of same design but different dimensions have been listed in the tables in Appendix A.

For walls, the existing element must be thicker than the one listed. For floor/ceiling assemblies, the assembly listed in the table must have the same or less cover and the same or thinner slab constructed of the same material as the actual floor/ceiling assembly. For other structural elements, the element listed in the table must be of a similar design but with less cover thickness. The fire resistance in all instances shall be the fire resistance recommended in the table. This is subject to the following limitations:

- The actual element in the rehabilitated building is constructed of the same materials as listed in the table. Only the following dimensions may vary from those specified: for walls, the overall thickness must exceed that specified in the table; for floor/ceiling assemblies, the thickness of the cover and the slab must be greater than or equal to that specified in the table; for other structural elements, the thickness of the cover must

be greater than that specified in the table.

- All penetrations in the building element or its cover for services such as electricity, plumbing, or HVAC are treated in a manner consistent with current practices for new construction using methods tested and documented for their fire endurance and anticipated durability. Descriptions of many such products and methods are available in fire resistance reference handbooks.
- The effects of age and wear and tear are repaired so that the building element is sound and the original thickness of all components, particularly covers and floor slabs, is maintained.

This approach is an application of the "thickness design" concept presented in Section 3.3. There should be many instances when a thicker building element was utilized than the one listed in the tables in Appendix A. This Guideline recognizes the inherent superiority of a thicker design. Note: "thickness design" for floor/ceiling assemblies and structural elements refers to cover and slab thickness rather than total thickness.

The "thickness design" concept is essentially a special case of Harmathy's Rules 1 and 2, where the source of data is Appendix A. If other sources are used, it must be in connection with the approach below.

4.3 General Application

The fire resistance of building elements can be established by applying Harmathy's Ten Rules of Fire Endurance Rating as set forth in Section 3.2, subject to the following

- The data from the tables can be utilized subject to the limitations in 4.2, above.
- Test reports from recognized journals or published papers can be used to support data utilized in applying Harmathy's Rules.
- Calculations utilizing recognized and well established computational techniques can be used in applying Harmathy's Rules. These include, but are not limited to, analysis of heat flow, mechanical properties, deflections, and load bearing capacity.

Appendix A—Fire Rating Tables

Table of Contents

Introduction	A-3
Section I—Walls	A-4
1.1.1 Masonry0"-4" thick	A-4
1.1.2 Masonry4"-6" thick	A-7
1.1.3 Masonry6"-8" thick	A-16
1.1.4 Masonry8"-10" thick	A-22
1.1.5 Masonry10"-12" thick	A-30
1.1.6 Masonry12"-14" thick	A-34
1.1.7 Masonry14" or more thick	A-40
1.2.1 Metal Frame0"-4" thick	A-43
1.2.2 Metal Frame4"-6" thick	A-47
1.2.3 Metal Frame6"-8" thick	A-49
1.2.4 Metal Frame8"-10" thick	A-50
1.3.1 Wood Frame0"-4" thick	A-51
1.3.2 Wood Frame4"-6" thick	A-52
1.3.3 Wood Frame6"-8" thick	A-61
1.4.1 Miscellaneous Materials0"-4" thick	A-62
1.4.2 Miscellaneous Materials4"-6" thick	A-62
1.5.1 Finish Ratings/Inorganic MaterialsThickness	A-63
1.5.2 Finish Ratings/Organic MaterialsThickness	A-65
Section II—Columns	A-66
2.1.1 Reinforced ConcreteMinimum Dimension 0"-6"	A-66
2.1.2 Reinforced ConcreteMinimum Dimension 10"-12"	A-67
2.1.3 Reinforced ConcreteMinimum Dimension 12"-14"	A-70
2.1.4 Reinforced ConcreteMinimum Dimension 14"-16"	A-71
2.1.5 Reinforced ConcreteMinimum Dimension 16"-18"	A-72
2.1.6 Reinforced ConcreteMinimum Dimension 18"-20"	A-74
2.1.7 Reinforced ConcreteMinimum Dimension 20"-22"	A-75
2.1.8 Hexagonal Reinforced ConcreteMinimum Dimension 12"-14"	A-77

2.1.9	Hexagonal Reinforced Concrete	Minimum Dimension 14"-16"	A-78
2.1.10	Hexagonal Reinforced Concrete	Minimum Dimension 16"-18"	A-78
2.1.11	Hexagonal Reinforced Concrete	Minimum Dimension 20"-22"	A-79
2.2	Round Cast Iron Columns	Minimum Dimension	A-79
2.3	Steel Columns/Gypsum Encasements	Minimum Area of Solid Material	A-80
2.4	Timber Columns	Minimum Dimension	A-82
2.5.1.1	Steel Columns/Concrete Encasements	Minimum Dimension less than 6"	A-82
2.5.1.2	Steel Columns/Concrete Encasements	Minimum Dimension 6"-8"	A-83
2.5.1.3	Steel Columns/Concrete Encasements	Minimum Dimension 8"-10"	A-84
2.5.1.4	Steel Columns/Concrete Encasements	Minimum Dimension 10"-12"	A-86
2.5.1.5	Steel Columns/Concrete Encasements	Minimum Dimension 12"-14"	A-90
2.5.1.6	Steel Columns/Concrete Encasements	Minimum Dimension 14"-16"	A-93
2.5.1.7	Steel Columns/Concrete Encasements	Minimum Dimension 16"-18"	A-95
2.5.2.1	Steel Columns/Brick and Block Encasements	Minimum Dimension 10"-12"	A-96
2.5.2.2	Steel Columns/Brick and Block Encasements	Minimum Dimension 12"-14"	A-97
2.5.2.3	Steel Columns/Brick and Block Encasements	Minimum Dimension 14"-16"	A-97
2.5.3.1	Steel Columns/Plaster Encasements	Minimum Dimension 6"-8"	A-98
2.5.3.2	Steel Columns/Plaster Encasements	Minimum Dimension 8"-10"	A-99
2.5.4.1	Steel Columns/Miscellaneous Encasements	Minimum Dimension 6"-8"	A-100
2.5.4.2	Steel Columns/Miscellaneous Encasements	Minimum Dimension 8"-10"	A-100
2.5.4.3	Steel Columns/Miscellaneous Encasements	Minimum Dimension 10"-12"	A-101
2.5.4.4	Steel Columns/Miscellaneous Encasements	Minimum Dimension 12"-14"	A-101
Section III—Floor/Ceiling Assemblies			A-102
3.1	Reinforced Concrete	Assembly Thickness	A-102
3.2	Steel Structural Elements	Membrane Thickness	A-108
3.3	Wood Joist	Membrane Thickness	A-113
3.4	Hollow Clay Tile with Reinforced Concrete	Assembly Thickness	A-118
Section IV—Beams			A-121
4.1.1	Reinforced Concrete	Depth 10"-12"	A-121
4.1.2	Reinforced Concrete	Depth 12"-14"	A-124
4.1.3	Reinforced Concrete	Depth 14"-16"	A-126
4.2.1	Steel/Unprotected	Depth 10"-12"	A-127
4.2.2	Steel/Concrete Protection	Depth 10"-12"	A-128
Section V Doors			A-129
5.1	Resistance of Doors to Fire Exposure	Thickness	A-129

Introduction

The tables and histograms that follow are to be used only within the analytical framework described in this Guideline.

Histograms precede any table with ten or more entries. The use and interpretation of the histograms is explained in Section 2, above.

The table format is similar to the one used by the model codes. Figure VI below, taken from an entry in Table 1.1.2, explains the column headings:

■ **Item Code.** This column contains the item code for each building element. The code consists of a four-place series, such as W-4-M-50, where:

W = type of building element;
W = walls, F = floors, etc.

4 = the building element thickness rounded **down** to the nearest one-inch increment (for example, 4 5/8" is rounded off to 4").

M = the general type of material from which the building element is constructed; M = masonry, W = wood, etc.

50 = the sequence number of the particular building element in a table.

■ **Thickness.** This column identifies the dimension with the greatest impact on fire resistance. The critical dimension for walls (the example shown here) is **thickness**, but it differs for other building elements. For instance, the critical dimension for beams is **depth** and for some floor/ceiling assemblies it is **membrane thickness**. The dimension shown is the one measured at the time of actual testing to within ±1/8-inch tolerance. The thickness includes facings when they are part of the wall construction.

■ **Construction Details.** This column provides a brief description of the building element.

■ **Performance.** This column is subdivided into two columns in most tables. The first is labeled "Load" and either lists the load that the building element was subjected to during the fire test or refers to a note at the bottom of the table that provides information on the load or other significant details. If the building element was not subjected to a load during the test, the entry will be "n/a" for "not applicable." The second

column is labeled "Time" and denotes the actual fire endurance time observed in the fire test.

■ **Reference Number.** This column refers to the 1942 National Bureau of Standards publication, Building Material Standard 92, "Fire-Resistance Classifications of Building Constructions" (1). The column is subdivided into three parts: Pre-BMS-92, BMS-92, and Post BMS-92. Table entries refer to the number of the entry in the bibliography containing the original source reference for the test data.

■ **Notes.** The entries in this column refer to notes at the end of the table that contain a more detailed explanation of certain aspects of the test. In some tables, note numbers also appear under the headings "Construction Details" and "Load."

■ **Rec Hours.** This column lists the recommended fire endurance rating, in hours or minutes, of the subject building element. This rating is always less than or equal to the rating under the "Time" column.

Item Code	Thickness	Construction Details	Performance		Reference Number			Notes	Rec Hours
			Load	Time	Pre BMS 92	BMS 92	Post-BMS 92		
W-4-M-50	4 5/8"	Core structural clay tile; see notes 12, 16, 21; facings on unexposed side only; see note 18.	n/a	25 min.	-	1	-	3,4,24	1/3

Figure VI. Sample Fire Rating Table.

Section I—Walls

Figure 1.1.1
Masonry Walls, 0" (00mm) to less than 4" (100mm) thick

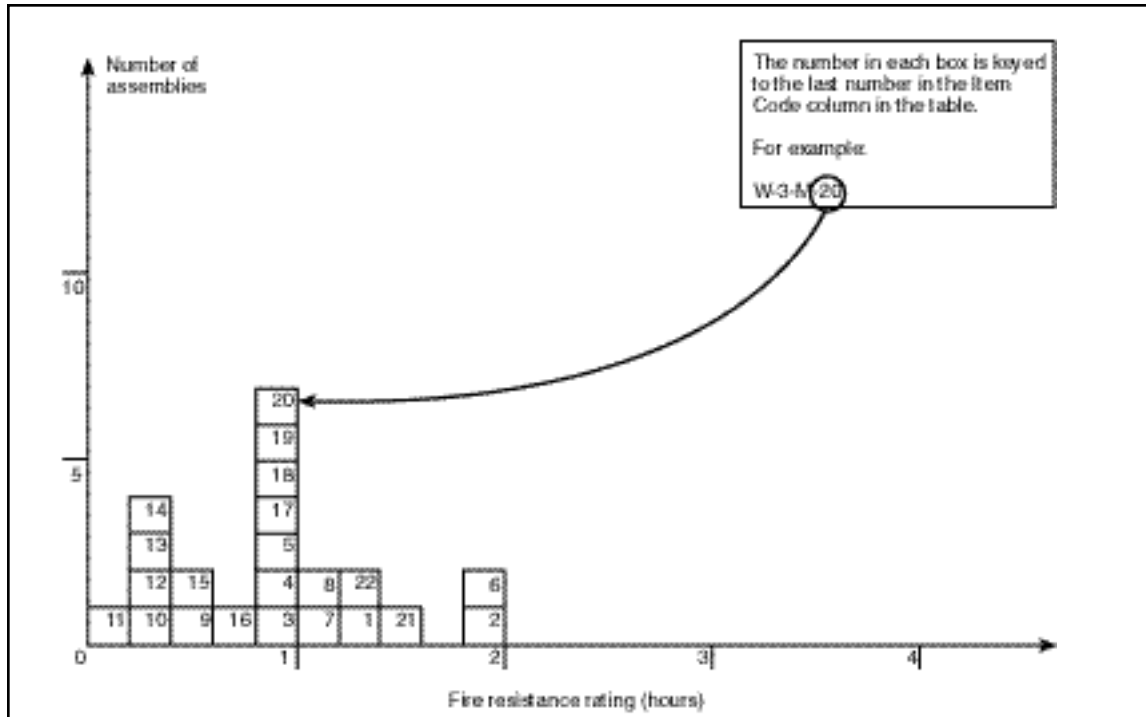

Table 1.1.1
Masonry Walls, 0" (00mm) to less than 4" (100mm) thick

Item Code	Thick-ness	Construction Details	Performance		Reference Number			Notes	Rec Hours
			Load	Time	Pre BMS 92	BMS	Post-BMS 92		
W-2-M-1	2 1/4"	Solid partition; 3/4" gypsum plank—10' x 1'6"; 3/4" + gypsum plaster each side	n/a	1 hr 22 min	-	-	7	1	1 1/4
W-3-M-2	3"	Concrete block (18" x 9" x 3") of fuel ash, portland cement and plasticizer; cement/sand mortar	n/a	2 hrs	-	-	7	2,3	2
W-2-M-3	2"	Solid gypsum block wall; no facings	n/a	1 hr	-	1	-	4	1
W-3-M-4	3"	Solid gypsum blocks, laid in 1:3 sanded gypsum mortar	n/a	1 hr	-	1	-	4	1
W-3-M-5	3"	Magnesium oxysulfate wood fiber blocks; 2" thick; laid in portland cement-lime mortar; facings 1/2" of 1:3 sanded gypsum plaster on both sides	n/a	1 hr	-	1	-	4	1

Table 1.1.1, continued (Masonry Walls, 0" to less than 4" thick)

Item Code	Thick-ness	Construction Details	Performance Load	Performance Time	Reference Number			Notes	Rec Hours
					Pre BMS 92	BMS	Post-BMS 92		
W-3-M-6	3"	Magnesium oxysulfate bound wood fiber blocks: 3" thick; laid in portland cement-lime mortar; facings: 1/2" of 1:3 sanded gypsum plaster on both sides	n/a	2 hrs	-	1	-	4	2
W-3-M-7	3"	Clay tile; Ohio fire clay; single cell thick; face plaster 5/8" (both sides) 1:3 sanded gypsum; construction "A"; design "E"	n/a	1 hr 6 min	-	-	2	5,6,7,11,12,39	1
W-3-M-8	3"	Clay tile; Illinois surface clay; single cell thick; face plaster 5/8" (both sides) 1:3 sanded gypsum; design "A"; construction "E"	n/a	1 hr 1 min	-	-	2	5,8,9,11,12,39	1
W-3-M-9	3"	Clay tile; Illinois surface clay; single cell thick; no face plaster; construction "C"; design "A"	n/a	25 min	-	-	2	5,10,11,12,39	1/3
W-3-M-10	3 7/8"	8" x 4 7/8" glass blocks; width 4 lb. each; portland cement-lime mortar; horizontal mortar joints reinforced with metal lath	n/a	15 min	-	1	-	4	1/4
W-3-M-11	3"	Core: structural clay tile; see notes 14, 18, 23; no facings	n/a	10 min	-	1	-	5,11,26	1/6
W-3-M-12	3"	Core: structural clay tile; see notes 14, 19, 23; no facings	n/a	20 min	-	1	-	5,11,26	1/3
W-3-M-13	3 5/8"	Core: structural clay tile; see notes 14, 18, 23; facings on unexposed side per note 20	n/a	20 min	-	1	-	5,11,26	1/3
W-3-M-14	3 5/8"	Core: structural clay tile; see notes 14, 19, 23; facings on unexposed side only per note 20	n/a	20 min	-	1	-	5,11,26	1/3
W-3-M-15	3 5/8"	Core: clay structural tile; see notes 14, 18, 23; facings on side exposed to fire per note 20	n/a	30 min	-	1	-	5,11,26	1/2
W-3-M-16	3 5/8"	Core: clay structural tile; see notes 14, 19, 23; facing on side exposed to fire per note 20	n/a	45 min	-	1	-	5,11,26	3/4
W-2-M-17	2"	2" thick solid gypsum blocks; see note 27	n/a	1 hr	-	1	-	27	1
W-3-M-18	3"	Core: 3" thick gypsum blocks 70% solid; see note 2; no facings	n/a	1 hr	-	1	-	27	1
W-3-M-19	3"	Core: hollow concrete units; see notes 29, 35, 36, 38; no facings	n/a	1 hr	-	1	-	27	1
W-3-M-20	3"	Core: hollow concrete units; see notes 28, 35, 36, 37, 38; no facings	n/a	1 hr	-	1	-	-	1
W-3-M-21	3 1/2"	Core: hollow concrete units; see notes 28, 35, 36, 37, 38; facings on one side, per note 37	n/a	1 hr 30 min	-	1	-	-	1 1/2
W-3-M-22	3 1/2"	Core: hollow concrete units; see notes 29, 35, 36, 38; facings on one side per note 37	n/a	1 hr 15 min	-	1	-	-	1 1/4

Table 1.1.1—Notes
Masonry Walls, 0" to less than 4" thick

1. Failure mode—flame thru.
2. Passed 2-hr fire test (Grade "C" fire res.—British).
3. Passed hose stream test.
4. Tested at NBS under ASA. Spec. No. A2-1934. As non-load bearing partitions.
5. Tested at NBS under ASASpec. No. A2-1934 (ASTM C-19-33) except that hose stream testing where carried out was run on test specimens exposed for full test duration, not for a reduced period as is contemporarily done.
6. Failure by thermal criteria—maximum temperature rise 181°C (325°F).
7. Hose stream failure.
8. Hose stream—pass.
9. Specimen removed prior to any failure occurring.
10. Failure mode—collapse.
11. For clay tile walls, unless the source or density of the clay can be positively identified or determined, it is suggested that the lowest hourly rating for the fire endurance of a clay tile partition of that thickness be followed. Identified sources of clay showing longer fire endurance can lead to longer time recommendations.
12. See appendix for construction and design details for clay tile walls.
13. Load—80 psi for gross wall area.
14. One cell in wall thickness.
15. Two cells in wall thickness.
16. Double shells plus one cell in wall thickness.
17. One cell in wall thickness, cells filled with broken tile, crushed stone, slag cinders or sand mixed with mortar.
18. Dense hard-burned clay or shale tile.
19. Medium-burned clay tile.
20. Not less than 5/8" thickness of 1:3 sanded gypsum plaster.
21. Units of not less than 30% solid material.
22. Units of not less than 40% solid material.
23. Units of not less than 50% solid material.
24. Units of not less than 45% solid material.
25. Units of not less than 60% solid material.
26. All tiles laid in portland cement-lime mortar.
27. Blocks laid in 1:3 sanded gypsum mortar voids in blocks not to exceed 30%.
28. Units of expanded slag or pumice aggregates.
29. Units of crushed limestone, blast furnace slag, cinders and expanded clay or shale.
30. Units of calcareous sand and gravel. Coarse aggregate, 60% or more calcite and dolomite.

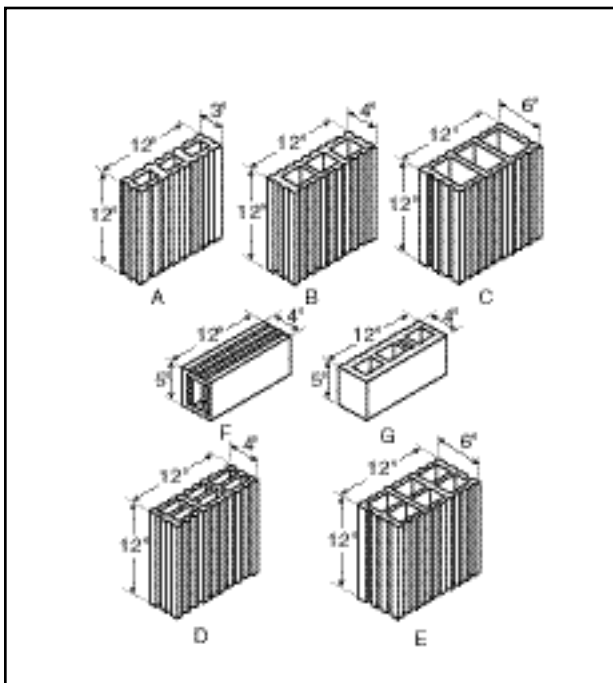

Note 39, Table 1.1.1. Designs of tiles used in fire-test partitions.

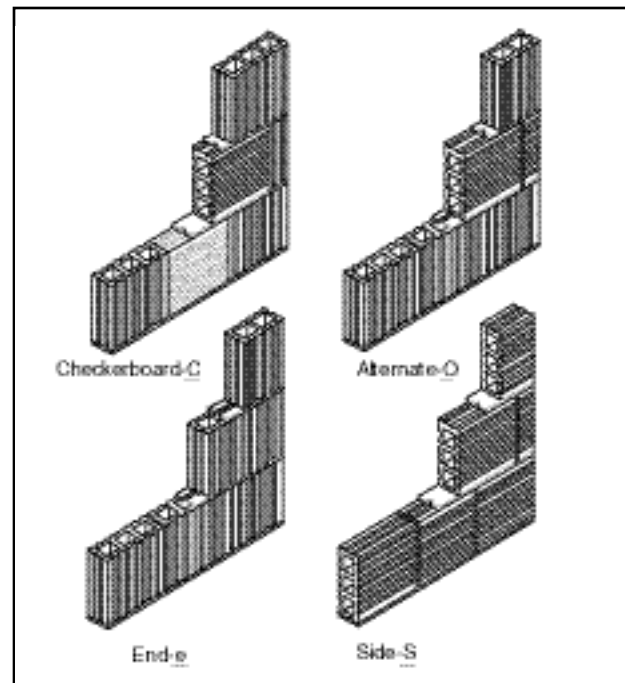

The four types of construction used in fire-test partitions.

Table 1.1.1—Notes, continued

- 31. Units of siliceous sand and gravel. 90% or more quartz, chert, or flint.
- 32. Unit at least 49% solid.
- 33. Unit at least 62% solid.
- 34. Unit at least 65% solid.
- 35. Unit at least 73% solid.
- 36. Ratings based on one unit and one cell in wall thickness.
- 37. Minimum of 1/2"—1:3 sanded gypsum plaster.
- 38. Non-load bearing.
- 39. See Clay Tile Partition Design Construction drawings, opposite page.

Figure 1.1.2
Masonry Walls, 4" (100 mm) to less than 6" (150 mm) thick

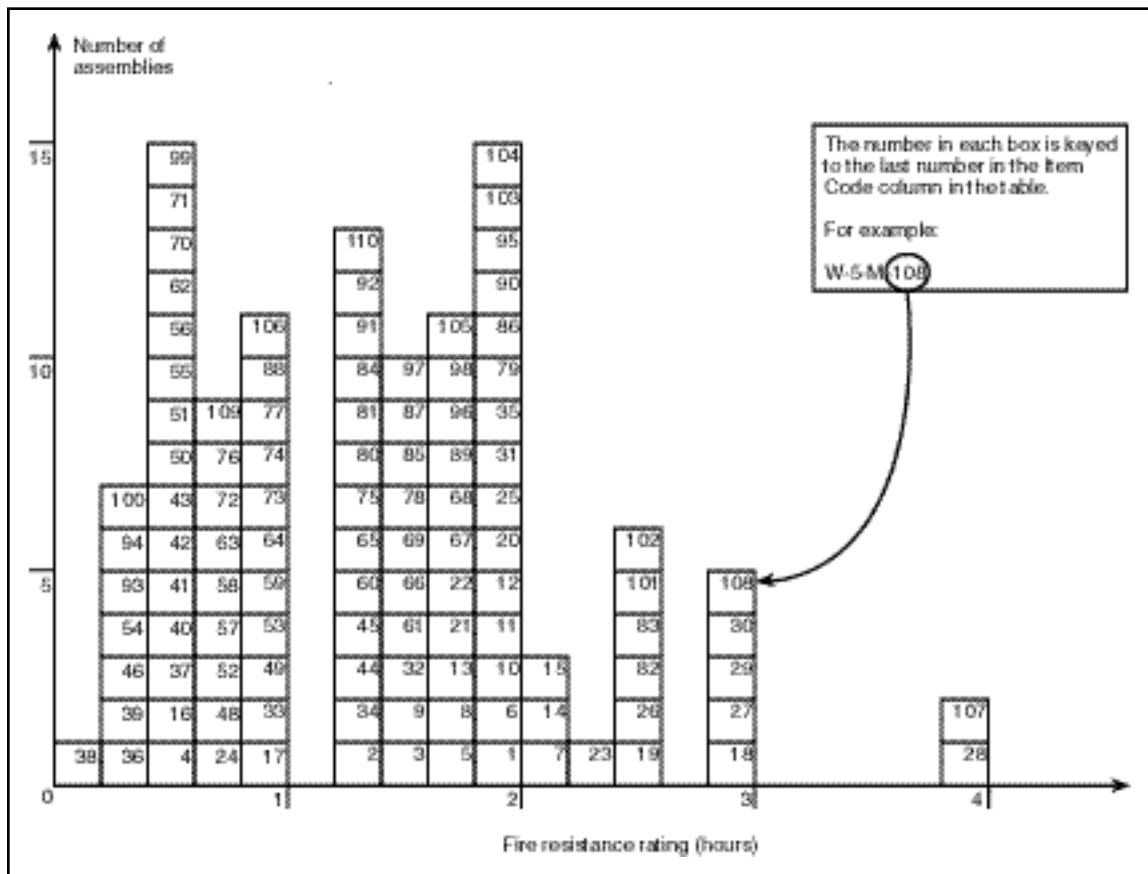

Table 1.1.2
Masonry Walls, 4" (100 mm) to less than 6" (150 mm) thick

Item Code	Thick-ness	Construction Details	Performance		Reference Number			Notes	Rec Hours
			Load	Time	Pre BMS 92	BMS	Post-BMS 92		
W-4-M-1	4"	Solid 3" thick, gypsum blocks laid in 1:3 sanded gypsum mortar; facings: 1/2" of 1:3 sanded gypsum plaster (both sides)	n/a	2 hrs	-	1	-	1	2
W-4-M-2	4"	Solid clay or shale brick	n/a	1 hr 15 min	-	1	-	1,2	1 1/4
W-4-M-3	4"	Concrete; no facings	n/a	1 hr 30 min	-	1	-	1	1 1/2
W-4-M-4	4"	Clay tile; Illinois surface clay; single cell thick; no face plaster; construc-tion "C"; design "B"	n/a	25 min	-	-	2	3-7,36	1/3
W-4-M-5	4"	Solid sand-lime brick	n/a	1 hr 45 min	-	1	-	1	1 3/4
W-4-M-6	4"	Solid wall; 3" thick block; 1/2" plaster each side; 17 3/4" x 8 3/4" x 3" "breeze blocks"; portland cement/sand mortar	n/a	1 hr 52 min	-	-	7	2	1 3/4
W-4-M-7	4"	Concrete (4020 psi); reinforcement: vertical 3/8"; horizontal 1/4"; 6" x 6" grid	3.4 tons/foot	2 hrs 10 min	-	-	7	2	2
W-4-M-8	4"	Concrete wall (4340 psi crush); reinforcement: 1/4" diameter rebar on 8" centers (vertical and horizontal)	n/a	1 hr 40 min	-	-	7	2	1 2/3
W-4-M-9	4 3/16"	4 3/16" x 2 5/8" cellular fletton brick (1873 psi) with 1/2" sand mortar; bricks are U-shaped yielding hollow cover (approx. 2" x 4") in final (cross-section) configuration	n/a	1 hr 25 min	-	-	7	2	1 1/3
W-4-M-10	4 1/4"	4 1/4" x 2 1/2" fletton brick (1831 psi) in 1/2" sand mortar	n/a	1 hr 53 min	-	-	7	2	1 3/4
W-4-M-11	4 1/4"	4 1/4" x 2 1/2" London stock brick; (683 psi) 1/2" grout	n/a	1 hr 52 min	-	-	7	2	1 3/4
W-4-M-12	4 1/4"	4 1/4" x 2 1/2" Leicester red, wire-cut brick (4465 psi) in 1/2" sand mortar	n/a	1 hr 56 min	-	-	7	6	1 3/4
W-4-M-13	4 1/4"	4 1/4" x 2 1/2" stairfoot brick (7527 psi) 1/2" sand mortar	n/a	1 hr 37 min	-	-	7	2	1 1/2
W-4-M-14	4 1/4"	4 1/4" x 2 1/2" sand-lime brick (2603 psi) 1/2" sand mortar	n/a	2 hrs 6 min	-	-	7	2	2
W-4-M-15	4 1/4"	4 1/4" x 2 1/2" concrete brick (2527 psi) 1/2" sand mortar	n/a	2 hrs 10 min	-	-	7	2	2
W-4-M-16	4 1/2"	4" thick clay tile; Ohio fire clay; single cell thick; no plaster exposed face; 1/2" 1:2 gypsum back face; construction "S"; design "F"	n/a	31 min	-	-	2	3-6,36	1/2

Table 1.1.2, continued (Masonry Walls, 4" to less than 6" thick)

Item Code	Thick-ness	Construction Details	Performance		Reference Number			Notes	Rec Hours
			Load	Time	Pre BMS 92	BMS	Post-BMS 92		
W-4-M-17	4 1/2"	4" thick clay tile; Ohio fire clay; single cell thick; plaster exposed face: 1/2"; 1:2 sanded gypsum; back face: none; design "F"; construction "S"	80 psi	50 min	-	-	2	3-5,8,36	3/4
W-4-M-18	4 1/2"	Core: solid sand-lime brick; 1/2" sanded gypsum plaster facings on both sides	80 psi	3 hrs	-	1	-	1,11	3
W-4-M-19	4 1/2"	Core: solid sand-lime brick; 1/2" sanded gypsum plaster facings on both sides	80 psi	2 hrs 30 min	-	1	-	1,11	2 1/2
W-4-M-20	4 1/2"	Core: concrete brick 1/2" of 1:3 sanded gypsum plaster facings on both sides	80 psi	2 hrs	-	1	-	1,11	2
W-4-M-21	4 1/2"	Core: solid clay or shale bricks; 1/2" thick, 1:3 sanded gypsum plaster facings on fire sides	80 psi	1 hr 45 min	-	1	-	1,2,11	1 3/4
W-4-M-22	4 3/4"	4" thick clay tile; Ohio fire clay; single cell thick; cells filled with cement and broken tile concrete; 3/4" 1:3 sanded gypsum plaster on exposed face; none on unexposed face; construction "E"; design "G"	n/a	1 hr 48 min	-	-	2	2,3-5,9,36	1 3/4
W-4-M-23	4 3/4"	4" thick clay tile; Ohio fire clay; single cell thick; cells filled with cement and broken tile concrete; no plaster exposed face; 3/4" neat gypsum plaster on unexposed face; design "G," construction "F"	n/a	2 hrs 14 min	-	-	2	2,3-5,9,36	2
W-5-M-24	5"	3" x 13" airspace; 1" thick metal reinforced concrete facings on both sides; faces connected with wood splines	2,250 lb/ft.	45 min	-	1	-	1	3/4
W-5-M-25	5"	Core: 3" thick void filled with "nodulated" mineral wool weighing 10 lbs/ft ³ ; 1" thick metal reinforced concrete facings on both sides	2,250 lb/ft.	2 hrs	-	1	-	1	2
W-5-M-26	5"	Core: solid clay or shale brick; 1/2" thick, 1:3 sanded gypsum plaster facings on both sides	40 psi	2 hrs 30 min	-	1	-	1,2,11	2 1/2
W-5-M-27	5"	Core: solid 4" thick gypsum blocks, laid in 1:3 sanded gypsum mortar; 1/2" of 1:3 sanded gypsum plaster facings on both sides	n/a	3 hrs	-	1	-	1	3
W-5-M-28	5"	Core: 4" thick hollow gypsum blocks with 30% voids; blocks laid in 1:3 sanded gypsum mortar; no facings	n/a	4 hrs	-	1	-	1	4
W-5-M-29	5"	Core: concrete brick; 1/2" of 1:3 sanded gypsum plaster facings on both sides	160 psi	3 hrs	-	1	-	1	3

Table 1.1.2, continued (Masonry Walls, 4" to less than 6" thick)

Item Code	Thick-ness	Construction Details	Performance Load	Performance Time	Reference Number			Notes	Rec Hours
					Pre BMS 92	BMS	Post-BMS 92		
W-5-M-30	5 1/4"	4" thick clay tile; Illinois surface clay; double cell thick; plaster 5/8" thick sanded gypsum 1:3 both faces; design "D"; construction "S"	n/a	2 hrs 53 min	-	-	2	2-5,9,36	2 3/4
W-5-M-31	5 1/4"	4" thick clay tile; New Jersey fire clay; double cell thick; plaster 5/8" sanded gypsum 1:3 both faces; design "D"; construction "S"	n/a	1 hr 52 min	-	-	2	2-5,9,36	1 3/4
W-5-M-32	5 1/4"	4" thick clay tile; New Jersey fire clay; single cell thick; 5/8" plaster on both sides; 1:3 sanded gypsum; design "D"; construction "S"	n/a	1 hr 34 min	-	-	2	2-5,9,36	1 1/2
W-5-M-33	5 1/4"	4" thick clay tile; New Jersey fire clay; single cell thick; face plaster 5/8" both sides; 1:3 sanded gypsum; construction "S"; design "B"	n/a	50 min	-	-	2	3-5,8,36	3/4
W-5-M-34	5 1/4"	4" thick clay tile; Ohio fire clay; single cell thick; face plaster 5/8" both sides; 1:3 sanded gypsum; construction "A"; design "B"	n/a	1 hr 19 min	-	-	2	2-5,9,36	1 1/4
W-5-M-35	5 1/4"	4" thick clay tile; Illinois surface clay; single cell thick; face plaster 5/8" both sides; 1:3 sanded gypsum; construction "S"; design "B"	n/a	1 hr 59 min	-	-	2	2-5,10,36	1 3/4
W-4-M-36	4"	Core: structural clay tile; see notes 12, 16, 21; no facings	n/a	15 min	-	1	-	3,4,24	1/4
W-4-M-37	4"	Core: structural clay tile; see notes 12, 17, 21; no facings	n/a	25 min	-	1	-	3,4,24	1/3
W-4-M-38	4"	Core: structural clay tile; see notes 12, 16, 20; no facings	n/a	10 min	-	1	-	3,4,24	1/6
W-4-M-39	4"	Core: structural clay tile; see notes 12, 17, 20; no facings	n/a	20 min	-	1	-	3,4,24	1/3
W-4-M-40	4"	Core: structural clay tile; see notes 13, 16, 23; no facings	n/a	30 min	-	1	-	3,4,24	1/2
W-4-M-41	4"	Core: structural clay tile; see notes 13, 17, 23; no facings	n/a	35 min	-	1	-	3,4,24	1/2
W-4-M-42	4"	Core: structural clay tile; see notes 13, 16, 21; no facings	n/a	25 min	-	1	-	3,4,24	1/3
W-4-M-43	4"	Core: structural clay tile; see notes 13, 17, 21; no facings	n/a	30 min	-	1	-	3,4,24	1/2
W-4-M-44	4"	Core: structural clay tile; see notes 15, 16, 20; no facings	n/a	1 hr 15 min	-	1	-	3,4,24	1 1/4
W-4-M-45	4"	Core: structural clay tile; see notes 15, 17, 20; no facings	n/a	1 hr 15 min	-	1	-	3,4,24	1 1/4
W-4-M-46	4"	Core: structural clay tile; see notes 14, 16, 22; no facings	n/a	20 min	-	1	-	3,4,24	1/3

Table 1.1.2, continued (Masonry Walls, 4" to less than 6" thick)

Item Code	Thick-ness	Construction Details	Performance		Reference Number			Notes	Rec Hours
			Load	Time	Pre BMS 92	BMS	Post-BMS 92		
W-4-M-47	4"	Core: structural clay tile; see notes 14, 17, 22; no facings	n/a	25 min	-	1	-	3,4,24	1/3
W-4-M-48	4 1/4"	Core: structural clay tile; see notes 12, 16, 21; facings on both sides; see note 18	n/a	45 min	-	1	-	3,4,24	3/4
W-4-M-49	4 1/4"	Core: structural clay tile; see notes 12, 17, 21; facings on both sides; see note 18	n/a	1 hr	-	1	-	3,4,24	1
W-4-M-50	4 5/8"	Core: structural clay tile; see notes 12, 16, 21; facings on unexposed side only; see note 18	n/a	25 min	-	1	-	3,4,24	1/3
W-4-M-51	4 5/8"	Core: structural clay tile; see notes 12, 17, 21; facings on unexposed side only; see note 18	n/a	30 min	-	1	-	3,4,24	1/2
W-4-M-52	4 5/8"	Core: structural clay tile; see notes 12, 16, 21; facings on exposed side only; see note 18	n/a	45 min	-	1	-	3,4,24	3/4
W-4-M-53	4 5/8"	Core: structural clay tile; see notes 12, 17, 21; facings on fire side only; see note 18	n/a	1 hr	-	1	-	3,4,24	1
W-4-M-54	4 5/8"	Core: structural clay tile; see notes 12, 16, 20; facings on unexposed side; see note 18	n/a	20 min	-	1	-	3,4,24	1/3
W-4-M-55	4 5/8"	Core: structural clay tile; see notes 12, 17, 20; facings on unexposed side; see note 18	n/a	25 min	-	1	-	3,4,24	1/3
W-4-M-56	4 5/8"	Core: structural clay tile; see notes 12, 16, 20; facings on fire side only; see note 18	n/a	30 min	-	1	-	3,4,24	1/2
W-4-M-57	4 5/8"	Core: structural clay tile; see notes 12, 17, 20; facings on fire side only; see note 18	n/a	45 min	-	1	-	3,4,24	3/4
W-4-M-58	4 5/8"	Core: structural clay tile; see notes 13, 16, 23; facings on unexposed side only; see note 18	n/a	40 min	-	1	-	3,4,24	2/3
W-4-M-59	4 5/8"	Core: structural clay tile; see notes 13, 17, 23; facing on unexposed side only; see note 18	n/a	1 hr	-	1	-	3,4,24	1
W-4-M-60	4 5/8"	Core: structural clay tile; see notes 13, 16, 23; facing on fire side only; see note 18	n/a	1 hr 15 min	-	1	-	3,4,24	1 1/4
W-4-M-61	4 5/8"	Core: structural clay tile; see notes 13, 17, 23; facing on fire side only; see note 18	n/a	1 hr 30 min	-	1	-	3,4,24	1 1/2
W-4-M-62	4 5/8"	Core: structural clay tile; see notes 13, 16, 21; facing on unexposed side only; see note 18	n/a	35 min	-	1	-	3,4,24	1/2
W-4-M-63	4 5/8"	Core: structural clay tile; see notes 13, 17, 21; facings on unexposed face only; see note 18	n/a	45 min	-	1	-	3,4,24	3/4

Table 1.1.2, continued (Masonry Walls, 4" to less than 6" thick)

Item Code	Thick-ness	Construction Details	Performance		Reference Number			Notes	Rec Hours
			Load	Time	Pre BMS 92	BMS	Post-BMS 92		
W-4-M-64	4 5/8"	Core: structural clay tile; see notes 13, 16, 23; facing on exposed face only; see note 18	n/a	1 hr	-	1	-	3,4,24	1
W-4-M-65	4 5/8"	Core: structural clay tile; see notes 13, 17, 21; facing on exposed side only; see note 18	n/a	1 hr 15 min	-	1	-	3,4,24	1 1/4
W-4-M-66	4 5/8"	Core: structural clay tile; see notes 15, 17, 20; facings on unexposed side only; see note 18	n/a	1 hr 30 min	-	1	-	3,4,24	1 1/2
W-4-M-67	4 5/8"	Core: structural clay tile; see notes 15, 16, 20; facings on exposed side only; see note 18	n/a	1 hr 45 min	-	1	-	3,4,24	1 3/4
W-4-M-68	4 5/8"	Core: structural clay tile; see notes 15, 17, 20; facings on exposed side only; see note 18	n/a	1 hr 45 min	-	1	-	3,4,24	1 3/4
W-4-M-69	4 5/8"	Core: structural clay tile; see notes 15, 16, 20; facings on unexposed side only; see note 18	n/a	1 hr 30 min	-	1	-	3,4,24	1 1/2
W-4-M-70	4 5/8"	Core: structural clay tile; see notes 14, 16, 22; facings on unexposed side only; see note 18	n/a	30 min	-	1	-	3,4,24	1/2
W-4-M-71	4 5/8"	Core: structural clay tile; see notes 14, 17, 22; facings on unexposed side only; see note 18	n/a	35 min	-	1	-	3,4,24	1/2
W-4-M-72	4 5/8"	Core: structural clay tile; see notes 14, 16, 22; facings on fire side of wall only; see note 18	n/a	45 min	-	1	-	3,4,24	3/4
W-4-M-73	4 5/8"	Core: structural clay tile; see notes 14, 17, 22; facings on fire side of wall only; see note 18	n/a	1 hr	-	1	-	3,4,24	1
W-5-M-74	5 1/4"	Core: structural clay tile; see notes 12, 16, 21; facings on both sides; see note 18	n/a	1 hr	-	1	-	3,4,24	1
W-5-M-75	5 1/4"	Core: structural clay tile; see notes 12, 17, 21; facings on both sides; see note 18	n/a	1 hr 15 min	-	1	-	3,4,24	1 1/4
W-5-M-76	5 1/4"	Core: structural clay tile; see notes 12, 16, 20; facings on both sides; see note 18	n/a	45 min	-	1	-	3,4,24	3/4
W-5-M-77	5 1/4"	Core: structural clay tile; see notes 12, 17, 20; facings on both sides; see note 18	n/a	1 hr	-	1	-	3,4,24	1
W-5-M-78	5 1/4"	Core: structural clay tile; see notes 13, 16, 23; facings on both sides of wall; see note 18	n/a	1 hr 30 min	-	1	-	3,4,24	1 1/2
W-5-M-79	5 1/4"	Core: structural clay tile; see notes 13, 17, 23; facings on both sides of wall; see note 18	n/a	2 hrs	-	1	-	3,4,24	2

Table 1.1.2, continued (Masonry Walls, 4" to less than 6" thick)

Item Code	Thick-ness	Construction Details	Performance Load	Performance Time	Reference Number			Notes	Rec Hours
					Pre BMS 92	BMS	Post-BMS 92		
W-5-M-80	5 1/4"	Core: structural clay tile; see notes 13, 16, 21; facings on both sides of wall; see note 18	n/a	1 hr 15 min	-	1	-	3,4,24	1 1/4
W-5-M-81	5 1/4"	Core: structural clay tile; see notes 13, 16, 21; facings on both sides of wall; see note 18	n/a	1 hr 30 min	-	1	-	3,4,24	1 1/2
W-5-M-82	5 1/4"	Core: structural clay tile; see notes 15, 16, 20; facings on both sides; see note 18	n/a	2 hrs 30 min	-	1	-	3,4,24	2 1/2
W-5-M-83	5 1/4"	Core: structural clay tile; see notes 15, 17, 20; facings on both sides; see note 18	n/a	2 hrs 30 min	-	1	-	3,4,24	2 1/2
W-5-M-84	5 1/4"	Core: structural clay tile; see notes 14, 16, 22; facings on both sides of wall; see note 18	n/a	1 hr 15 min	-	1	-	3,4,24	1 1/4
W-5-M-85	5 1/4"	Core: structural clay tile; see notes 14, 17, 22; facings on both sides of wall; see note 18	n/a	1 hr 30 min	-	1	-	3,4,24	1 1/2
W-4-M-86	4"	Core: 3" thick gypsum blocks 70% solid; see note 26; facings on both sides per note 25	n/a	2 hrs	-	1	-	-	2
W-4-M-87	4"	Core: hollow concrete units; see notes 27, 34, 35; no facings	n/a	1 hr 30 min	-	1	-	-	1 1/2
W-4-M-88	4"	Core: hollow concrete units; see notes 28, 33, 35; no facings	n/a	1 hr	-	1	-	-	1
W-4-M-89	4"	Core: hollow concrete units; see notes 28, 34, 35; facings on both sides per note 25	n/a	1 hr 45 min	-	1	-	-	1 3/4
W-4-M-90	4"	Core: hollow concrete units; see notes 27, 34, 35; facings on both sides per note 25	n/a	2 hrs	-	1	-	-	2
W-4-M-91	4"	Core: hollow concrete units; see notes 27, 32, 35; no facings	n/a	1 hr 15 min	-	1	-	-	1 1/4
W-4-M-92	4"	Core: hollow concrete units; see notes 28, 34, 35; no facings	n/a	1 hr 15 min	-	1	-	-	1 1/4
W-4-M-93	4"	Core: hollow concrete units; see notes 29, 32, 35; no facings	n/a	20 min	-	1	-	-	1/3
W-4-M-94	4"	Core: hollow concrete units; see notes 30, 34, 35; no facings	n/a	15 min	-	1	-	-	1/4
W-4-M-95	4 1/2"	Core: hollow concrete units; see notes 27, 34, 35; facing on one side only; see note 25	n/a	2 hrs	-	1	-	-	2
W-4-M-96	4 1/2"	Core: hollow concrete units; see notes 27, 32, 35; facing on one side only; see note 25	n/a	1 hr 45 min	-	1	-	-	1 3/4
W-4-M-97	4 1/2"	Core: hollow concrete units; see notes 28, 33, 35; facing on one side per note 25	n/a	1 hr 30 min	-	1	-	-	1 1/2

Table 1.1.2, continued (Masonry Walls, 4" to less than 6" thick)

Item Code	Thick-ness	Construction Details	Performance		Reference Number			Notes	Rec Hours
			Load	Time	Pre BMS 92	BMS	Post-BMS 92		
W-4-M-98	4 1/2"	Core: hollow concrete units; see notes 28, 34, 35; facing on one side only per note 25	n/a	1 hr 45 min	-	1	-	-	1 3/4
W-4-M-99	4 1/2"	Core: hollow concrete units; see notes 29, 32, 35; facing on one side per note 25	n/a	30 min	-	1	-	-	1/2
W-4-M-100	4 1/2"	Core: hollow concrete units; see notes 30, 34, 35; facing on one side per note 25	n/a	20 min	-	1	-	-	1/3
W-5-M-101	5"	Core: hollow concrete units; see notes 27, 34, 35; facings on both sides; see note 25	n/a	2 hrs 30 min	-	1	-	-	2 1/2
W-5-M-102	5"	Core: hollow concrete units; see notes 27, 32, 35; facings on both sides per note 25	n/a	2 hrs 30 min	-	1	-	-	2 1/2
W-5-M-103	5"	Core: hollow concrete units; see notes 28, 33, 35; facings on both sides per note 25	n/a	2 hrs	-	1	-	-	2
W-5-M-104	5"	Core: hollow concrete units; see notes 28, 31, 35; facings on both sides per note 25	n/a	2 hrs	-	1	-	-	2
W-5-M-105	5"	Core: hollow concrete units; see notes 29, 32, 35; facings on both sides per note 25	n/a	1 hr 45 min	-	1	-	-	1 3/4
W-5-M-106	5"	Core: hollow concrete units; see notes 30, 34, 35; facings on both sides per note 25	n/a	1 hr	-	1	-	-	1
W-5-M-107	5"	Core: 5" thick solid gypsum blocks; see note 26; no facings	n/a	4 hrs	-	1	-	-	4
W-5-M-108	5"	Core: 4" thick hollow gypsum blocks; see note 26; facings on both sides per note 25	n/a	3 hrs	-	1	-	-	3
W-5-M-109	4"	Concrete with 4" x 4" No. 6 welded wire mesh at wall center	100 psi	45 min	-	-	43	2	3/4
W-5-M-110	4"	Concrete with 4" x 4" No. 6 welded wire mesh at wall center	n/a	1 hr 15 min	-	-	43	2	1 1/4

Table 1.1.2—Notes
Masonry Walls, 4" to less than 6" thick

1. Tested at NBS under ASASpec. No. A-2-1934.
2. Failure mode—maximum temperature rise.
3. Tested at NBS under ASASpec. No. 42-1934 (ASTM C-19-53) except that hose stream testing where carried out was run on test specimens exposed for full test duration, not for a reduced period as is temporarily done.
4. For clay tile walls, unless the source of the clay can be positively identified, it is suggested that the most pessimistic hour rating for the fire endurance of a clay tile partition of that thickness be followed. Identified sources of clay showing longer fire endurance can lead to longer time recommendations.
5. See appendix for construction and design details for clay tile walls.
6. Failure mode—flame thru or crack formation showing flames.
7. Hole formed at 25 minutes; partition collapsed at 42 minutes on removal from furnace.
8. Failure mode—collapse.

Table 1.1.2—Notes, continued

9. Hose stream pass.
10. Hose stream hole formed in specimen.
11. Load—80 psi for gross wall cross-sectioned area.
12. One cell in wall thickness.
13. Two cells in wall thickness.
14. Double cells plus one cell in wall thickness.
15. One cell in wall thickness, cells filled with broken tile, crushed stone, slag, cinders, or sand mixed with mortar.
16. Dense hard-burned clay or shale tile.
17. Medium-burned clay tile.
18. Not less than 5/8" thickness of 1:3 sanded gypsum plaster.
19. Units of not less than 30% solid material.
20. Units of not less than 40% solid material.
21. Units of not less than 50% solid material.
22. Units of not less than 45% solid material.
23. Units of not less than 60% solid material.
24. All tiles laid in portland cement-lime mortar.
25. Minimum 1/2" of 1:3 sanded gypsum plaster.
26. Laid in 1:3 sanded gypsum mortar. Voids in hollow units not to exceed 30%.
27. Units of expanded slag or pumice aggregate.
28. Units of crushed limestone, blast furnace slag, cinders, and expanded clay or shale.
29. Units of calcareous sand and gravel. Coarse aggregate, 60% or more calcite and dolomite.
30. Units of siliceous sand and gravel. 90% or more quartz, chert, or flint.
31. Unit at least 49% solid.
32. Unit at least 62% solid.
33. Unit at least 65% solid.
34. Unit at least 73% solid.
35. Ratings based on one unit and one cell in wall thickness.
36. See Clay Tile Partition Design Construction drawings, below.

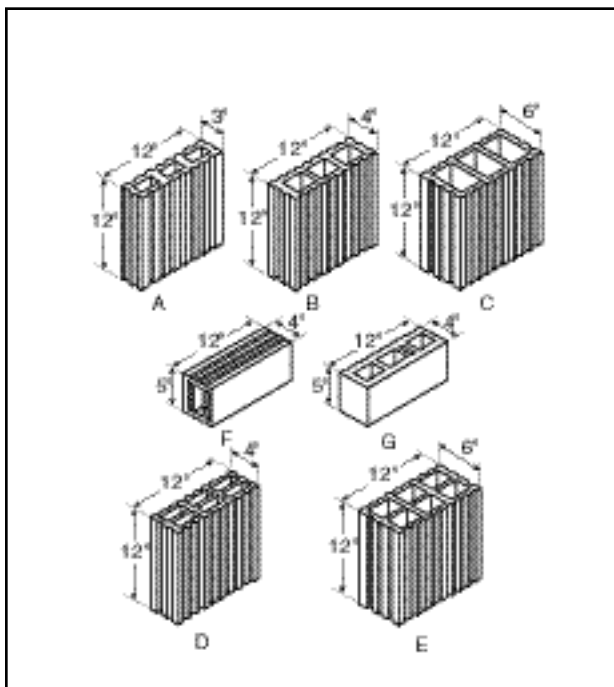

Note 36, Table 1.1.2. Designs of tiles used in fire-test partitions.

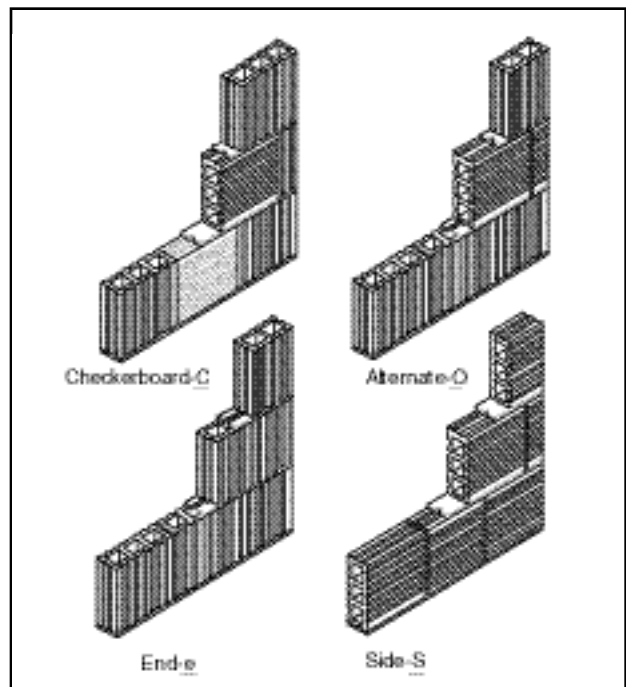

The four types of construction used in fire-test partitions.

Figure 1.1.3
Masonry Walls, 6" (150 mm) to less than 8" (200 mm) thick

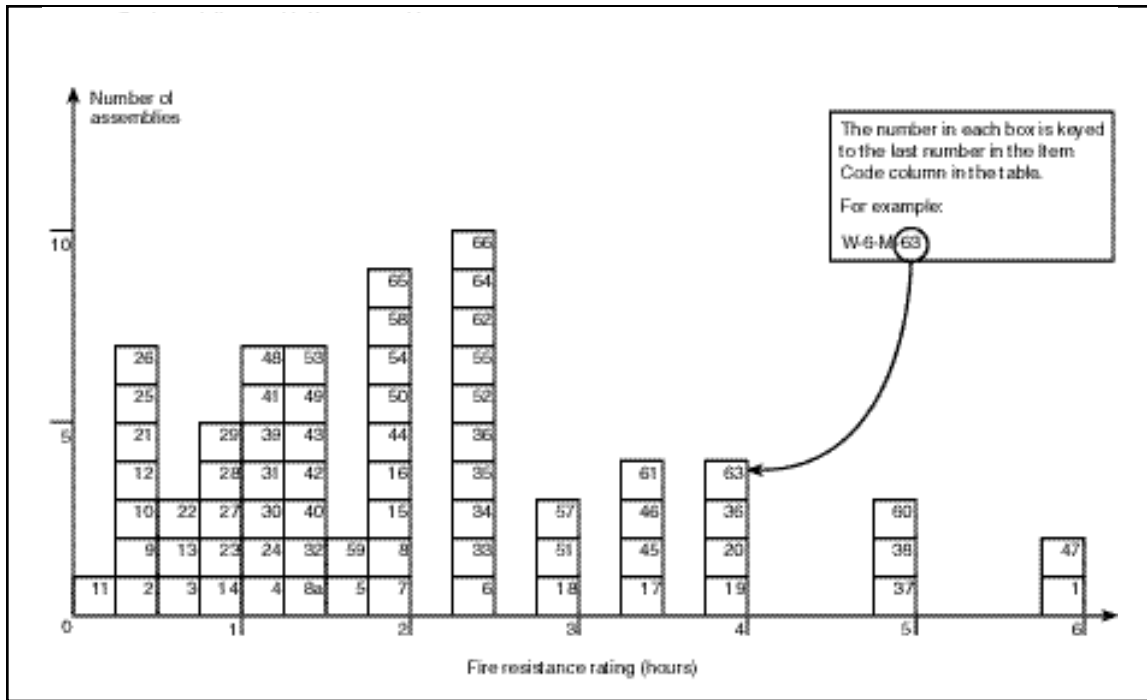

Table 1.1.3
Masonry Walls, 6" (150 mm) to less than 8" (200 mm) thick

Item Code	Thick-ness	Construction Details	Performance		Reference Number			Notes	Rec Hours
			Load	Time	Pre BMS 92	BMS	Post-BMS 92		
W-6-M-1	6"	Core: 5" thick, solid gypsum blocks laid in 1:3 sanded gypsum mortar; 1/2" of 1:3 sanded gypsum plaster facings on both sides	n/a	6 hrs	-	1	-	-	6
W-6-M-2	6"	6" clay tile; Ohio fire clay; single cell thick; no plaster; design "C"; construction "A"	n/a	17 min	-	-	2	1,3,4,6,55	1/4
W-6-M-3	6"	6" clay tile; Illinois surface clay; double cell thick; no plaster; design "E"; construction "S"	n/a	45 min	-	-	2	1-4,7,55	3/4
W-6-M-4	6"	6" clay tile; New Jersey fire clay; double cell thick; no plaster; design "E"; construction "S"	n/a	1 hr 1 min	-	-	2	1-4,8,55	1
W-7-M-5	7 1/4"	6" clay tile; Illinois surface clay; double cell thick; plaster: 5/8" of 1:3 sanded gypsum both faces; design "E"; construction "A"	n/a	1 hr 41 min	-	-	2	1-4,55	1 2/3

Table 1.1.3, continued (Masonry Walls, 6" to less than 8" thick)

Item Code	Thick-ness	Construction Details	Performance		Reference Number			Notes	Rec Hours
			Load	Time	Pre BMS 92	BMS	Post-BMS 92		
W-7-M-6	7 1/4"	6" clay tile; New Jersey fire clay; double cell thick; plaster: 5/8" of 1:3 sanded gypsum both faces; design "E"; construction "S"	n/a	2 hrs 23 min	-	-	2	1-4,9,55	2 1/3
W-7-M-7	7 1/4"	6" clay tile; Ohio fire clay; single cell thick; plaster: 5/8" sanded gypsum; 1:3 both faces; design "C"; construction "A"	n/a	1 hr 54 min	-	-	2	1-4,9,55	2 3/4
W-7-M-8	7 1/4"	6" clay tile; Illinois surface clay; single cell thick; plaster: 5/8" sanded gypsum 1:3 both faces; design "C"; construction "S"	n/a	2 hrs	-	-	2	1,3,4,9,10,55	2
W-7-M-8a	7 1/4"	6" clay tile; Illinois surface clay; single cell thick; plaster: 5/8" sanded gypsum 1:3 both faces; design "C"; construction "E"	n/a	1 hr 23 min	-	-	2	1-4,9,10,55	1 1/4
W-6-M-9	6"	Core: structural clay tile; see notes 12, 16, 20; no facings	n/a	20 min	-	1	-	3,5,24	1/3
W-6-M-10	6"	Core: structural clay tile; see notes 12, 17, 20; no facings	n/a	25 min	-	1	-	3,5,24	1/3
W-6-M-11	6"	Core: structural clay tile; see notes 12, 16, 19; no facings	n/a	15 min	-	1	-	3,5,24	1/4
W-6-M-12	6"	Core: structural clay tile; see notes 12, 17, 19; no facings	n/a	20 min	-	1	-	3,5,24	1/3
W-6-M-13	6"	Core: structural clay tile; see notes 13, 16, 22; no facings	n/a	45 min	-	1	-	3,5,24	3/4
W-6-M-14	6"	Core: structural clay tile; see notes 13, 17, 22; no facings	n/a	1 hr	-	1	-	3,5,24	1
W-6-M-15	6"	Core: structural clay tile; see notes 15, 17, 19; no facings	n/a	2 hrs	-	1	-	3,5,24	2
W-6-M-16	6"	Core: structural clay tile; see notes 15, 16, 19; no facings	n/a	2 hrs	-	1	-	3,5,24	2
W-6-M-17	6"	Cored concrete masonry; see notes 12, 34, 36, 38, 41; no facings	80 psi	3 hrs 30 min	-	1	-	5,25	3 1/2
W-6-M-18	6"	Cored concrete masonry; see notes 12, 33, 36, 38, 41; no facings	80 psi	3 hrs	-	1	-	5,25	3
W-6-M-19	6 1/2"	Cored concrete masonry; see notes 12, 34, 36, 38, 41; facings: see note 35 for side 1	80 psi	4 hrs	-	1	-	5,25	4
W-6-M-20	6 1/2"	Cored concrete masonry; see notes 12, 33, 36, 38, 41; facings: see note 35 for side 1	80 psi	4 hrs	-	1	-	5,25	4
W-6-M-21	6 5/8"	Core: structural clay tile; see notes 12, 16, 20; facing: unexposed face only; see note 18	n/a	30 min	-	1	-	3,5,24	1/2
W-6-M-22	6 5/8"	Core: structural clay tile; see notes 12, 17, 20; facing: unexposed face only; see note 18	n/a	40 min	-	1	-	3,5,24	2/3

Table 1.1.3, continued (Masonry Walls, 6" to less than 8" thick)

Item Code	Thick-ness	Construction Details	Performance		Reference Number			Notes	Rec Hours
			Load	Time	Pre BMS 92	BMS	Post-BMS 92		
W-6-M-23	6 5/8"	Core: structural clay tile; see notes 12, 16, 20; facing: exposed face only; see note 18	n/a	1 hr	-	1	-	3,5,24	1
W-6-M-24	6 5/8"	Core: structural clay tile; see notes 12, 17, 20; facing: exposed face only; see note 18	n/a	1 hr 5 min	-	1	-	3,5,24	1
W-6-M-25	6 5/8"	Core: structural clay tile; see notes 12, 16, 19; facing: unexposed side only; see note 18	n/a	25 min	-	1	-	3,5,24	1/3
W-6-M-26	6 5/8"	Core: structural clay tile; see notes 12, 17, 19; facings: on unexposed side only; see note 18	n/a	30 min	-	1	-	3,5,24	1/2
W-6-M-27	6 5/8"	Core: structural clay tile; see notes 12, 16, 19; facings: on exposed side only; see note 18	n/a	1 hr	-	1	-	3,5,24	1
W-6-M-28	6 5/8"	Core: structural clay tile; see notes 12, 17, 19; facings: on fire side only; see note 18	n/a	1 hr	-	1	-	3,5,24	1
W-6-M-29	6 5/8"	Core: structural clay tile; see notes 13, 16, 22; facings: on unexposed side only; see note 18	n/a	1 hr	-	1	-	3,5,24	1
W-6-M-30	6 5/8"	Core: structural clay tile; see notes 13, 17, 22; facings: on unexposed side only; see note 18	n/a	1 hr 15 min	-	1	-	3,5,24	1 1/4
W-6-M-31	6 5/8"	Core: structural clay tile; see notes 13, 16, 22; facings: on fire side only; see note 18	n/a	1 hr 15 min	-	1	-	3,5,24	1 1/4
W-6-M-32	6 5/8"	Core: structural clay tile; see notes 13, 17, 22; facing: on fire side only; see note 18	n/a	1 hr 30 min	-	1	-	3,5,24	1 1/2
W-6-M-33	6 5/8"	Core: structural clay tile; see notes 15, 16, 19; facings: on unexposed side only; see note 18	n/a	2 hrs 30 min	-	1	-	3,5,24	2 1/2
W-6-M-34	6 5/8"	Core: structural clay tile; see notes 15, 17, 19; facings: on unexposed side only; see note 18	n/a	2 hrs 30 min	-	1	-	3,5,24	2 1/2
W-6-M-35	6 5/8"	Core: structural clay tile; see notes 15, 16, 19; facings: on fire side only; see note 18	n/a	2 hrs 30 min	-	1	-	3,5,24	2 1/2
W-6-M-36	6 5/8"	Core: structural clay tile; see notes 15, 17, 19; facings: on fire side only; see note 18	n/a	2 hrs 30 min	-	1	-	3,5,24	2 1/2
W-7-M-37	7"	Cored concrete masonry; see notes 12, 34, 36, 38, 41; see note 35 for facings on both sides	80 psi	5 hrs	-	1	-	5,25	5
W-7-M-38	7"	Cored concrete masonry; see notes 12, 33, 36, 38, 41; see note 35 for facings	80 psi	5 hrs	-	1	-	5,25	5

Table 1.1.3, continued (Masonry Walls, 6" to less than 8" thick)

Item Code	Thick-ness	Construction Details	Performance		Reference Number			Notes	Rec Hours
			Load	Time	Pre BMS 92	BMS	Post-BMS 92		
W-7-M-39	7 1/4"	Core: structural clay tile; see notes 12, 16, 20; see note 18 for facings on both sides	n/a	1 hr 15 min	-	1	-	3,5,24	1 1/4
W-7-M-40	7 1/4"	Core: structural clay tile; see notes 12, 17, 20; see note 18 for facings on both sides	n/a	1 hr 30 min	-	1	-	3,5,24	1 1/2
W-7-M-41	7 1/4"	Core: structural clay tile; see notes 12, 16, 19; see note 18 for facings on both sides	n/a	1 hr 15 min	-	1	-	3,5,24	1 1/4
W-7-M-42	7 1/4"	Core: structural clay tile; see notes 12, 17, 19; see note 18 for facings on both sides	n/a	1 hr 30 min	-	1	-	3,5,24	1 1/2
W-7-M-43	7 1/4"	Core: structural clay tile; see notes 13, 16, 22; facing: on both sides of wall; see note 18	n/a	1 hr 30 min	-	1	-	3,5,24	1 1/2
W-7-M-44	7 1/4"	Core: structural clay tile; see notes 13, 17, 22; facings: on both sides of wall; see note 18	n/a	2 hrs	-	1	-	3,5,24	2
W-7-M-45	7 1/4"	Core: structural clay tile; see notes 15, 16, 19; facings: both sides; see note 18	n/a	3 hrs 30 min	-	1	-	3,5,24	3 1/2
W-7-M-46	7 1/4"	Core: structural clay tile; see notes 15, 17, 19; facings: both sides; see note 18	n/a	3 hrs 30 min	-	1	-	3,5,24	3 1/2
W-6-M-47	6"	Core: 5" thick solid gypsum blocks; see note 45; facings: both sides per note 35	n/a	6 hrs	-	1	-	-	6
W-6-M-48	6"	Core: hollow concrete units; see notes 47, 50, 54; no facings	n/a	1 hr 15 min	-	1	-	-	1 1/4
W-6-M-49	6"	Core: hollow concrete units; see notes 46, 50, 54; no facings	n/a	1 hr 30 min	-	1	-	-	1 1/2
W-6-M-50	6"	Core: hollow concrete units; see notes 41, 46, 54; no facings	n/a	2 hrs	-	1	-	-	2
W-6-M-51	6"	Core: hollow concrete units; see notes 46, 53, 54; no facings	n/a	3 hrs	-	1	-	-	3
W-6-M-52	6"	Core: hollow concrete units; see notes 47, 53, 54; no facings	n/a	2 hrs 30 min	-	1	-	-	2 1/2
W-6-M-53	6"	Core: hollow concrete units; see notes 47, 51, 54; no facings	n/a	1 hr 30 min	-	1	-	-	1 1/2
W-6-M-54	6 1/2"	Core: hollow concrete units; see notes 46, 50, 54; facing: one side only per note 35	n/a	2 hrs	-	1	-	-	2
W-6-M-55	6 1/2"	Core: hollow concrete units; see notes 46, 51, 54; facings: one side only per note 35	n/a	2 hrs 30 min	-	1	-	-	2 1/2
W-6-M-56	6 1/2"	Core: hollow concrete units; see notes 46, 53, 54; facings: one side only per note 35	n/a	4 hrs	-	1	-	-	4

Table 1.1.3, continued (Masonry Walls, 6" to less than 8" thick)

Item Code	Thick-ness	Construction Details	Performance		Reference Number			Notes	Rec Hours
			Load	Time	Pre BMS 92	BMS	Post-BMS 92		
W-6-M-57	6 1/2"	Core: hollow concrete units; see notes 47, 53, 54; facings: one side only per note 35	n/a	3 hrs	-	1	-	-	3
W-6-M-58	6 1/2"	Core: hollow concrete units; see notes 47, 51, 54; facings: one side only per note 35	n/a	2 hrs	-	1	-	-	2
W-6-M-59	6 1/2"	Core: hollow concrete units; see notes 47, 50, 54; facings: one side only per note 35	n/a	1 hr 45 min	-	1	-	-	1 3/4
W-7-M-60	7"	Core: hollow concrete units; see notes 46, 53, 54; facings: both sides per note 35	n/a	5 hrs	-	1	-	-	5
W-7-M-61	7"	Core: hollow concrete units; see notes 46, 51, 54; facings: both sides per note 35	n/a	3 hrs 30 min	-	1	-	-	3 1/2
W-7-M-62	7"	Core: hollow concrete units; see notes 46, 50, 54; facings: both sides per note 35	n/a	2 hrs 30 min	-	1	-	-	2 1/2
W-7-M-63	7"	Core: hollow concrete units; see notes 47, 53, 54; facings: both sides per note 35	n/a	4 hrs	-	1	-	-	4
W-7-M-64	7"	Core: hollow concrete units; see notes 47, 51, 54; facings: both sides per note 35	n/a	2 hrs 30 min	-	1	-	-	2 1/2
W-7-M-65	7"	Core: hollow concrete units; see notes 47, 50, 54; facings: both sides per note 35	n/a	2 hrs	-	1	-	-	2
W-6-M-66	6"	Concrete wall with 4"x4" No. 6 wire fabric (welded) near wall center for reinforcement.	300 psi	2 hrs. 30 min	-	-	43	2	2 1/2

Table 1.1.3—Notes
Masonry Walls, 6" to less than 8" thick

1. Tested at NBS under ASASpec. No. A2-1934 (ASTM C-19-53) except that hose stream testing where carried out was run on test specimens exposed for full test duration, not for a reduced period as is contemporarily done.
2. Failure by thermal criteria—maximum temperature rise.
3. For clay tile walls, unless the source or density of the clay can be positively identified or determined, it is suggested that the lowest hourly rating for the fire endurance of a clay tile partition of that thickness be followed. Identified sources of clay showing longer fire endurance can lead to longer time recommendations.
4. See note 55 for construction and design details for clay tile walls.
5. Tested at NBS under ASASpec. No. A2-1934.
6. Failure mode—collapse.
7. Collapsed on removal from furnace @ 1 hour 9 minutes.
8. Hose stream—failed.
9. Hose stream—passed.
10. No end point met in test.
11. Wall collapsed at 1 hour 28 minutes.
12. One cell in wall thickness.
13. Two cells in wall thickness.
14. Double shells plus one cell in wall thickness.
15. One cell in wall thickness, cells filled with broken tile, crushed stone, slag, cinders, or sand mixed with mortar.
16. Dense hard-burned clay or shale tile.
17. Medium-burned clay tile.
18. Not less than 5/8" thickness of 1:3 sanded gypsum plaster.
19. Units of not less than 30% solid material.

Table 1.1.3—Notes, continued

- 20. Units of not less than 40% solid material.
- 21. Units of not less than 50% solid material.
- 22. Units of not less than 45% solid material.
- 23. Units of not less than 60% solid material.
- 24. All tiles laid in portland cement-lime mortar.
- 25. Load—80 psi for gross cross-sectional area of wall.
- 26. Three cells in wall thickness.
- 27. Minimum % of solid material in concrete units: 52.
- 28. Minimum % of solid material in concrete units: 54.
- 29. Minimum % of solid material in concrete units: 55.
- 30. Minimum % of solid material in concrete units: 57.
- 31. Minimum % of solid material in concrete units: 62.
- 32. Minimum % of solid material in concrete units: 65.
- 33. Minimum % of solid material in concrete units: 70.
- 34. Minimum % of solid material in concrete units: 76.
- 35. Not less than 1/2" of 1:3 sanded gypsum plaster.
- 36. Noncombustible or no members framed into wall.
- 37. Combustible members framed into wall.
- 38. One unit in wall thickness.
- 39. Two units in wall thickness.

- 40. Three units in wall thickness.
- 41. Concrete units made with expanded slag or pumice aggregates.
- 42. Concrete units made with expanded burned clay or shale, crushed limestone, air-cooled slag, or cinders.
- 43. Concrete units made with calcareous sand and gravel. Coarse aggregate, 60% or more calcite and dolomite.
- 44. Concrete units made with siliceous sand and gravel. 90% or more quartz, chert, or flint.
- 45. Laid in 1:3 sanded gypsum mortar.
- 46. Units of expanded slag or pumice aggregate.
- 47. Units of crushed limestone, blast furnace slag, cinders, and expanded clay or shale.
- 48. Units of calcareous sand and gravel. Coarse aggregate, 60% or more calcite and dolomite.
- 49. Units of siliceous sand and gravel. 90% or more quartz, chert, or flint.
- 50. Unit minimum 49% solid.
- 51. Unit minimum 62% solid.
- 52. Unit minimum 65% solid.
- 53. Unit minimum 73% solid.
- 54. Ratings based on one unit and one cell in wall section.
- 55. See Clay Tile Partition Design Construction drawings, below.

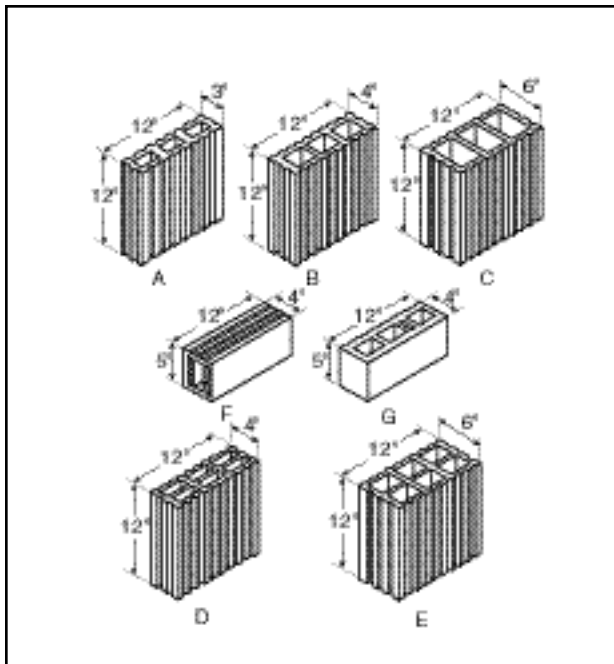

Note 55, Table 1.1.3. Designs of tiles used in fire-test partitions.

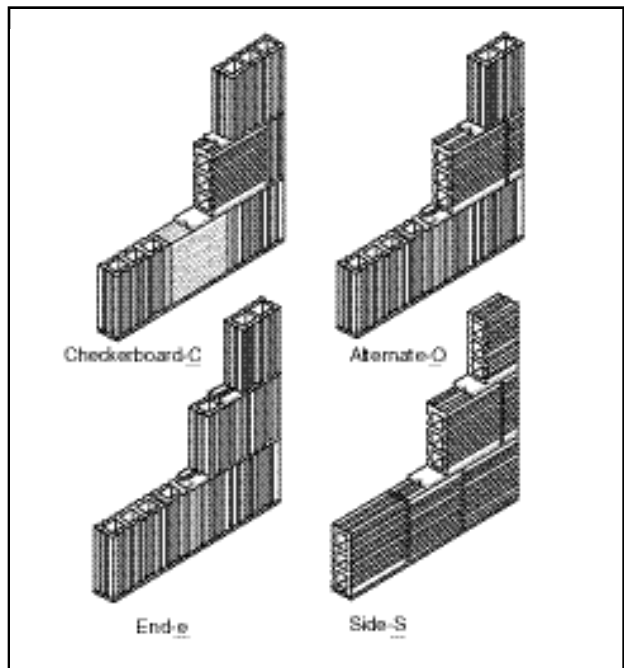

The four types of construction used in fire-test partitions.

Figure 1.1.4
Masonry Walls, 8" (200 mm) to less than 10" (250 mm) thick

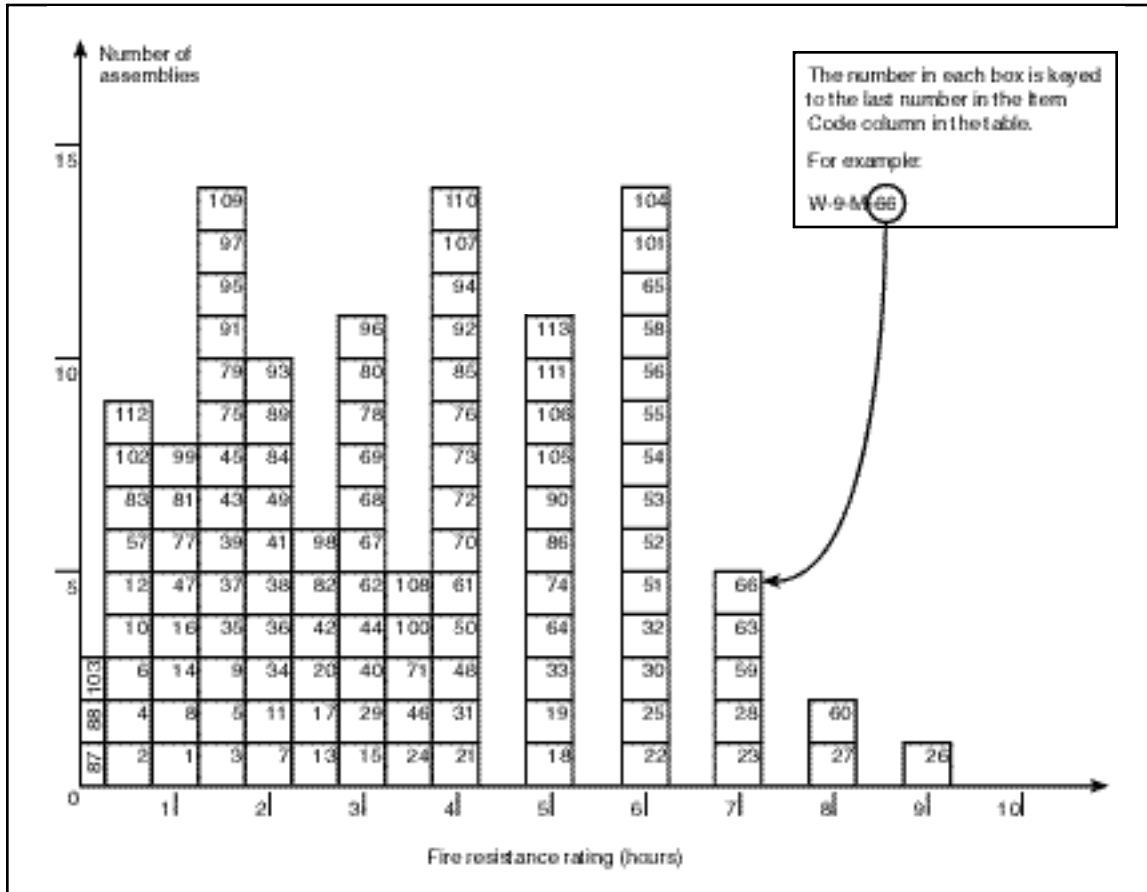

Table 1.1.4
Masonry Walls, 8" (200 mm) to less than 10" (250 mm) thick

Item Code	Thick-ness	Construction Details	Performance		Reference Number			Notes	Rec Hours
			Load	Time	Pre BMS 92	BMS	Post-BMS 92		
W-8-M-1	8"	Core: clay or shale structural tile; units in wall thickness: 1; cells in wall thickness: 2; minimum % solids in units: 40	80 psi	1 hr 15 min	-	1	-	1,20	1 1/4
W-8-M-2	8"	Core: clay or shale structural tile; units in wall thickness: 1; cell in wall thickness: 2; minimum % solids in units: 40; facings: none; result for wall with combustible members framed into interior	80 psi	45 min	-	1	-	1,20	3/4

Table 1.1.4, continued (Masonry Walls, 8" to less than 10" thick)

Item Code	Thick-ness	Construction Details	Performance		Reference Number			Notes	Rec Hours
			Load	Time	Pre BMS 92	BMS	Post-BMS 92		
W-8-M-3	8"	Core: clay or shale structural tile; units in wall thickness: 1; cells in wall thickness: 2; minimum % solids in units: 43	80 psi	1 hr 30 min	-	1	-	1,20	1 1/2
W-8-M-4	8"	Core: clay or shale structural tile; units in wall thickness: 1; cells in wall thickness: 2; minimum % solids in units: 43; no facings; combustible members framed into wall	80 psi	45 min	-	1	-	1,20	3/4
W-8-M-5	8"	Core: clay or shale structural tile; no facings	See notes	1 hr 30 min	-	1	-	1,2,5,10,18,20,21	1 1/2
W-8-M-6	8"	Core: clay or shale structural tile; no facings	See notes	45 min	-	1	-	1,2,5,10,19-21	3/4
W-8-M-7	8"	Core: clay or shale structural tile; no facings	See notes	2 hrs	-	1	-	1,2,5,13,18,20,21	2
W-8-M-8	8"	Core: clay or shale structural tile; no facings	See notes	1 hr 15 min	-	1	-	1,2,5,13,19,20,21	1 1/4
W-8-M-9	8"	Core: clay or shale structural tile; no facings	See notes	1 hr 45 min	-	1	-	1,2,6,9,18,20,21	1 3/4
W-8-M-10	8"	Core: clay or shale structural tile; no facings	See notes	45 min	-	1	-	1,2,6,9,19,20,21	3/4
W-8-M-11	8"	Core: clay or shale structural tile; no facings	See notes	2 hrs	-	1	-	1,2,6,10,18,20,21	2
W-8-M-12	8"	Core: clay or shale structural tile; no facings	See notes	45 min	-	1	-	1,2,6,10,19,20,21	3/4
W-8-M-13	8"	Core: clay or shale structural tile; no facings	See notes	2 hrs 30 min	-	1	-	1,3,6,12,18,20,21	2 1/2
W-8-M-14	8"	Core: clay or shale structural tile; no facings	See notes	1 hr	-	1	-	1,2,6,12,19,20,21	1
W-8-M-15	8"	Core: clay or shale structural tile; no facings	See notes	3 hrs	-	1	-	1,2,6,16,18,20,21	3
W-8-M-16	8"	Core: clay or shale structural tile; no facings	See notes	1 hr 15 min	-	1	-	1,2,6,16,19,20,21	1 1/4
W-8-M-17	8"	Units in wall thickness: 1; cells in wall thickness: 1; minimum % solids: 70; cored clay or shale brick; no facings	See notes	2 hrs 30 min	-	1	-	1,44	2 1/2
W-8-M-18	8"	Cored clay or shale bricks; units in wall thickness: 2; cells in wall thickness: 2; minimum % solids: 87; no facings	See notes	5 hrs	-	1	-	1,45	5
W-8-M-19	8"	Core: solid clay or shale brick; no facings	See notes	5 hrs	-	1	-	1,22,45	5
W-8-M-20	8"	Core: hollow rolok of clay or shale	See notes	2 hrs 30 min	-	1	-	1,22,45	2 1/2
W-8-M-21	8"	Core: hollow rolok of clay or shale; no facings	See notes	4 hrs	-	1	-	1,45	4

Table 1.1.4, continued (Masonry Walls, 8" to less than 10" thick)

Item Code	Thick-ness	Construction Details	Performance		Reference Number			Notes	Rec Hours
			Load	Time	Pre BMS 92	BMS	Post-BMS 92		
W-8-M-22	8"	Core: concrete brick; no facings	See notes	6 hrs	-	1	-	1,45	6
W-8-M-23	8"	Core: sand-lime brick; no facings	See notes	7 hrs	-	1	-	1,45	7
W-8-M-24	8"	Core: 4"; 40% solid clay or shale structural tile; 1 side 4" brick facing	See notes	3 hrs 30 min	-	1	-	1,20	3 1/2
W-8-M-25	8"	Concrete wall (3220 psi); reinforcing vertical rods 1" from each face and 1" diameter; horizontal rod 3/8" diameter	22,200 lb/ft	6 hrs	-	-	7	-	6
W-8-M-26	8"	Core: sand-lime brick; 1/2" of 1:3 sanded gypsum plaster facing on one side	See notes	9 hrs	-	1	-	1,45	9
W-8-M-27	8 1/2"	Core: sand-lime brick; 1/2" of 1:3 sanded gypsum plaster facing on one side	See notes	8 hrs	-	1	-	1,45	8
W-8-M-28	8 1/2"	Core: concrete; 1/2" of 1:3 sanded gypsum plaster facing on one side	See notes	7 hrs	-	1	-	1,45	7
W-8-M-29	8 1/2"	Core: hollow rolok of clay or shale; 1/2" of 1:3 sanded gypsum plaster facing on one side	See notes	3 hrs	-	1	-	1,45	3
W-8-M-30	8 1/2"	Core: solid clay or shale brick; 1/2" thick, 1:3 sanded gypsum plaster facing on one side	See notes	6 hrs	-	1	-	1,22,45	6
W-8-M-31	8 1/2"	Core: cored clay or shale brick; units in wall thickness: 1; cells in wall thickness: 1; minimum % solids: 70; 1/2" of 1:3 sanded gypsum plaster facing on both sides	See notes	4 hrs	-	1	-	1,44	4
W-8-M-32	8 1/2"	Core: cored clay or shale brick; units in wall thickness: 2; cells in wall thickness: 2; minimum % solids: 87; 1/2" of 1:3 sanded gypsum plaster facing on one side	See notes	6 hrs	-	1	-	1,45	6
W-8-M-33	8 1/2"	Hollow rolok bak of clay or shale core; 1/2" of 1:3 sanded gypsum plaster facing on one side	See notes	5 hrs	-	1	-	1,45	5
W-8-M-34	8 5/8"	Core: clay or shale structural tile; units in wall thickness: 1; cells in wall thickness: 2; minimum % solids in units: 40; 5/8" of 1:3 sanded gypsum plaster facing on one side	See notes	2 hrs	-	1	-	1,20,21	2
W-8-M-35	8 5/8"	Core: clay or shale structural tile; units in wall thickness: 1; cells in wall thickness: 2; minimum % solids in units: 40; exposed face: 5/8" of 1:3 sanded gypsum plaster	See notes	1 hr 30 min	-	1	-	1,20,21	1 1/2
W-8-M-36	8 5/8"	Core: clay or shale structural tile; units in wall thickness: 1; cells in wall thickness: 2; minimum % solids in units: 43; 5/8" of 1:3 sanded gypsum plaster facing on one side	See notes	2 hrs	-	-	-	1,20,21	2

Table 1.1.4, continued (Masonry Walls, 8" to less than 10" thick)

Item Code	Thick-ness	Construction Details	Performance		Reference Number			Notes	Rec Hours
			Load	Time	Pre BMS 92	BMS	Post-BMS 92		
W-8-M-37	8 5/8"	Core: clay or shale structural tile; units in wall thickness: 1; cells in wall thickness: 2; minimum % solids in units: 43; 5/8" of 1:3 sanded gypsum plaster on the exposed face only	See notes	1 hr 30 min	-	1	-	1,20,21	1 1/2
W-8-M-38	8 5/8"	Core: clay or shale structural tile; see note 17 for facing side 1	See notes	2 hrs	-	1	-	1,2,5,10,18, 20,21	2
W-8-M-39	8 5/8"	Core: clay or shale structural tile; facings: on exposed side only; see note 17	See notes	1 hr 30 min	-	1	-	1,2,5,10,19, 20,21	1 1/2
W-8-M-40	8 5/8"	Core: clay or shale structural tile; facings on exposed side only; see note 17	See notes	3 hrs	-	1	-	1,2,5,13,18, 20,21	3
W-8-M-41	8 5/8"	Core: clay or shale structural tile; facings on exposed side only; see note 17	See notes	2 hrs	-	1	-	1,2,5,13,19, 20,21	2
W-8-M-42	8 5/8"	Core: clay or shale structural tile; facings on side 1; see note 17	See notes	2 hrs 30 min	-	1	-	1,2,6,9,18, 20,21	2 1/2
W-8-M-43	8 5/8"	Core: clay or shale structural tile; facings on exposed side only per note 17	See notes	1 hr 30 min	-	1	-	1,2,6,9,19, 20,21	1 1/2
W-8-M-44	8 5/8"	Core: clay or shale structural tile; facings: side 1—see note 17; side 2—none	See notes	3 hrs	-	1	-	1,2,6,10,18, 20,21	3
W-8-M-45	8 5/8"	Core: clay or shale structural tile; facings on fire side only; see note 17	See notes	1 hr 30 min	-	1	-	1,2,6,10,19, 20,21	1 1/2
W-8-M-46	8 5/8"	Core: clay or shale structural tile; facings: side 1—see note 17; side 2—none	See notes	3 hrs 30 min	-	1	-	1,2,6,12,18, 20,21	3 1/2
W-8-M-47	8 5/8"	Core: clay or shale structural tile; facings exposed side only; see note 17	See notes	1 hr 45 min	-	1	-	1,2,6,12,19, 20,21	1 3/4
W-8-M-48	8 5/8"	Core: clay or shale structural tile; facings: side 1—see note 17; side 2—none	See notes	4 hrs	-	1	-	1,2,6,16,18, 20,21	4
W-8-M-49	8 5/8"	Core: clay or shale structural tile; facings: fire side only; see note 17	See notes	2 hrs	-	1	-	1,2,6,16,19, 20,21	2
W-8-M-50	8 5/8"	Core: 4"; 40% solid clay or shale structural tile; 4" brick plus 5/8" of 1:3 sanded gypsum plaster facing on one side	See notes	4 hrs	-	1	-	1,20	4
W-8-M-51	8 3/4"	8 3/4" x 2 1/2" and 4" x 2 1/2" cellular fletton (1873 psi) single and triple cell hollow bricks set in 1/2" sand mortar in alt. courses	3.6 ton/ft	6 hrs	-	-	7	23,29	6
W-8-M-52	8 3/4"	8 3/4" thick cement brick (2527 psi) with P.C. and sand mortar	3.6 ton/ft	6 hrs	-	-	7	23,24	6

Table 1.1.4, continued (Masonry Walls, 8" to less than 10" thick)

Item Code	Thick-ness	Construction Details	Performance		Reference Number			Notes	Rec Hours
			Load	Time	Pre BMS 92	BMS	Post-BMS 92		
W-8-M-53	8 3/4"	8 3/4" x 2 1/2" fletton brick (1831 psi) in 1/2" sand mortar	3.6 ton/ft	6 hrs	-	-	7	23,24	6
W-8-M-54	8 3/4"	8 3/4" x 2 1/2" London stock brick (683 psi) in 1/2" portland cement and sand mortar	7.2 ton/ft	6 hrs	-	-	7	23,24	6
W-9-M-55	9"	9" x 2 1/2" Leicester red wire cut brick (4465 psi) in 1/2" portland cement and sand mortar	6.0 ton/ft	6 hrs	-	-	7	23,24	6
W-9-M-56	9"	9" x 3" sand-lime brick (2603 psi) in 1/2" in portland cement and sand mortar	3.6 ton/ft	6 hrs	-	-	7	23,24	6
W-9-M-57	9"	2 layers 2 7/8" fletton brick (1910 psi) with 3 1/4" air space; cement and sand mortar	1.5 ton/ft	32 min	-	-	7	23,25	1/3
W-9-M-58	9"	9" x 3" stairfoot brick (7527 psi) in 1/2" sand-cement mortar	7.2 ton/ft	6 hrs	-	-	7	23,24	6
W-9-M-59	9"	Core: solid clay or shale brick; 1/2" thick; 1:3 sanded gypsum plaster facing on both sides	See notes	7 hrs	-	1	-	1,45,22	7
W-9-M-60	9"	Core: concrete brick; 1/2" of 1:3 sanded gypsum plaster facings on both sides	See notes	8 hrs	-	1	-	1,45	8
W-9-M-61	9"	Core: hollow rolok of clay or shale; 1/2" of 1:3 sanded gypsum plaster facings on both sides	See notes	4 hrs	-	1	-	1,45	4
W-9-M-62	9"	Core: clay or shale brick; units in wall thickness: 1; cells in wall thickness: 1; minimum % solids: 70; 1/2" of 1:3 sanded gypsum plaster facing on one side	See notes	3 hrs	-	1	-	1,44	3
W-9-M-63	9"	Core: clay or shale brick; units in wall thickness: 2; cells in wall thickness: 2; minimum % solids: 87; 1/2" of 1:3 sanded gypsum plaster facing on both sides	See notes	7 hrs	-	1	-	1,45	7
W-9-M-64	9-10"	Core: cavity wall of clay or shale brick; no facings	See notes	5 hrs	-	1	-	1,45	5
W-9-M-65	9-10"	Core: cavity construction of clay or shale brick; 1/2" of 1:3 sanded gypsum plaster facing on one side	See notes	6 hrs	-	1	-	1,45	6
W-9-M-66	9-10"	Core: cavity construction of clay or shale brick; 1/2" of 1:3 sanded gypsum plaster facing on both sides	See notes	7 hrs	-	1	-	1,45	7
W-9-M-67	9 1/4"	Core: clay or shale structural tile; units in wall thickness: 1; cells in wall thickness: 2; minimum % solids in units: 40; 5/8" of 1:3 sanded gypsum plaster facing on both sides	See notes	3 hrs	-	1	-	1,20,21	3

Table 1.1.4, continued (Masonry Walls, 8" to less than 10" thick)

Item Code	Thick-ness	Construction Details	Performance		Reference Number			Notes	Rec Hours
			Load	Time	Pre BMS 92	BMS	Post-BMS 92		
W-9-M-68	9 1/4"	Core: clay or shale structural tile; units in wall thickness: 1; cells in wall thickness: 2; minimum % solids in units: 43; 5/8" of 1:3 sanded gypsum plaster facings on both sides	See notes	3 hrs	-	1	-	1,20,21	3
W-9-M-69	9 1/4"	Core: clay or shale structural tile; facings: side 1 and 2 see note 17	See notes	3 hrs	-	1	-	1,2,5,10,18,20,21	3
W-9-M-70	9 1/4"	Core: clay or shale structural tile; facings: side 1 and 2 see note 17	See notes	4 hrs	-	1	-	1,2,5,13,18,20,21	4
W-9-M-71	9 1/4"	Core: clay or shale structural tile; facings: side 1 and 2 see note 17	See notes	3 hrs 30 min	-	1	-	1,2,6,9,18,20,21	3 1/2
W-9-M-72	9 1/4"	Core: clay or shale structural tile; facings: side 1 and 2 see note 17	See notes	4 hrs	-	1	-	1,2,6,10,18,20,21	4
W-9-M-73	9 1/4"	Core: clay or shale structural tile; facings: side 1 and 2 see note 17	See notes	4 hrs	-	1	-	1,2,6,12,18,20,21	4
W-9-M-74	9 1/4"	Core: clay or shale structural tile; facings: side 1 and 2 see note 17	See notes	5 hrs	-	1	-	1,2,6,16,18,20,21	5
W-8-M-75	8"	Core: concrete masonry; see notes 2, 19, 26, 34, 40; no facings	80 psi	1 hr 30 min	-	1	-	1,20	1 1/2
W-8-M-76	8"	Cored concrete masonry; see notes 2, 18, 26, 34, 40; no facings	80 psi	4 hrs	-	1	-	1,20	4
W-8-M-77	8"	Cored concrete masonry; see notes 2, 19, 26, 31, 40; no facings	80 psi	1 hr 15 min	-	1	-	1,20	1 1/4
W-8-M-78	8"	Cored concrete masonry; see notes 2, 18, 26, 31, 40; no facings	80 psi	3 hrs	-	1	-	1,20	3
W-8-M-79	8"	Cored concrete masonry; see notes 2, 19, 26, 36, 41; no facings	80 psi	1 hr 30 min	-	1	-	1,20	1 1/2
W-8-M-80	8"	Cored concrete masonry; see notes 2, 18, 26, 36, 41; no facings	80 psi	3 hrs	-	1	-	1,20	3
W-8-M-81	8"	Cored concrete masonry; see notes 2, 19, 26, 34, 41; no facings	80 psi	1 hr	-	1	-	1,20	1
W-8-M-82	8"	Cored concrete masonry; see notes 2, 18, 26, 34, 41; no facings	80 psi	2 hrs 30 min	-	1	-	1,20	2 1/2
W-8-M-83	8"	Cored concrete masonry; see notes 2, 19, 26, 29, 41; no facings	80 psi	45 min	-	1	-	1,20	3/4
W-8-M-84	8"	Cored concrete masonry; see notes 2, 18, 26, 29, 41; no facings	80 psi	2 hrs	-	1	-	1,20	2
W-8-M-85	8"	Cored concrete masonry; see notes 3, 18, 26, 34, 41; facings: 2 1/2" brick	80 psi	4 hrs	-	1	-	1,20	4
W-8-M-86	8"	Cored concrete masonry; see notes 3, 18, 26, 34, 41; facings: 3 3/4" brick face	80 psi	5 hrs	-	1	-	1,20	5
W-8-M-87	8"	Cored concrete masonry; see notes 2, 19, 26, 30, 43; no facings	80 psi	12 min	-	1	-	1,20	1/5

Table 1.1.4, continued (Masonry Walls, 8" to less than 10" thick)

Item Code	Thick-ness	Construction Details	Performance		Reference Number			Notes	Rec Hours
			Load	Time	Pre BMS 92	BMS	Post-BMS 92		
W-8-M-88	8"	Cored concrete masonry; see notes 2, 18, 26, 30, 43; no facings	80 psi	12 min	-	1	-	1,20	1/5
W-8-M-89	8 1/2"	Cored concrete masonry; see notes 2, 19, 26, 34, 40; facings: on fire side only; see note 38	80 psi	2 hrs	-	1	-	1,20	2
W-8-M-90	8 1/2"	Cored concrete masonry; see notes 2, 18, 26, 34, 40; facings: see note 38 for side 1	80 psi	5 hrs	-	1	-	1,20	5
W-8-M-91	8 1/2"	Cored concrete masonry; see notes 2, 19, 26, 31, 40; facings on fire side only; see note 38	80 psi	1 hr 45 min	-	1	-	1,20	1 3/4
W-8-M-92	8 1/2"	Cored concrete masonry; see notes 2, 18, 26, 31, 40; facings on one side; see note 38	80 psi	4 hrs	-	1	-	1,20	4
W-8-M-93	8 1/2"	Cored concrete masonry; see notes 2, 19, 26, 36, 41; facings on fire side only; see note 38	80 psi	2 hrs	-	1	-	1,20	2
W-8-M-94	8 1/2"	Cored concrete masonry; see notes 2, 18, 26, 36, 41; facings on fire side only; see note 38	80 psi	4 hrs	-	1	-	1,20	4
W-8-M-95	8 1/2"	Cored concrete masonry; see notes 2, 19, 26, 34, 41; facings on fire side only; see note 38	80 psi	1 hr 30 min	-	1	-	1,20	1 1/2
W-8-M-96	8 1/2"	Cored concrete masonry; see notes 2, 18, 26, 34, 41; facings on one side; see note 38	80 psi	3 hrs	-	1	-	1,20	3
W-8-M-97	8 1/2"	Cored concrete masonry; see notes 2, 19, 26, 29, 41; facings on fire side only; see note 38	80 psi	1 hr 30 min	-	1	-	1,20	1 1/2
W-8-M-98	8 1/2"	Cored concrete masonry; see notes 2, 18, 26, 29, 41; facings on one side; see note 38	80 psi	2 hrs 30 min	-	1	-	1,20	2 1/2
W-8-M-99	8 1/2"	Cored concrete masonry; see notes 3, 19, 23, 27, 41; no facings	80 psi	1 hr 15 min	-	1	-	1,20	1 1/4
W-8-M-100	8 1/2"	Cored concrete masonry; see notes 3, 18, 23, 27, 41; no facings	80 psi	3 hrs 30 min	-	1	-	1,20	3 1/2
W-8-M-101	8 1/2"	Cored concrete masonry; see notes 3, 18, 26, 34, 41; facings 3 3/4" brick face; one side only; see note 38	80 psi	6 hrs	-	1	-	1,20	6
W-8-M-102	8 1/2"	Cored concrete masonry; see notes 2, 19, 26, 30, 43; facings on fire side only; see note 38	80 psi	30 min	-	1	-	1,20	1/2
W-8-M-103	8 1/2"	Cored concrete masonry; see notes 2, 18, 26, 30, 43; facings on one side only; see note 38	80 psi	12 min	-	1	-	1,20	1/5
W-9-M-104	9"	Cored concrete masonry; see notes 2, 18, 26, 34, 40; facings on both sides; see note 38	80 psi	6 hrs	-	1	-	1,20	6

Table 1.1.4, continued (Masonry Walls, 8" to less than 10" thick)

Item Code	Thick-ness	Construction Details	Performance		Reference Number			Notes	Rec Hours
			Load	Time	Pre BMS 92	BMS	Post-BMS 92		
W-9-M-105	9"	Cored concrete masonry; see notes 2, 18, 26, 31, 40; facings on both sides; see note 38	80 psi	5 hrs	-	1	-	1,20	5
W-9-M-106	9"	Cored concrete masonry; see notes 2, 18, 26, 36, 41; facings on both sides of wall; see note 38	80 psi	5 hrs	-	1	-	1,20	5
W-9-M-107	9"	Cored concrete masonry; see notes 2, 18, 26, 34, 41; facings on both sides; see note 38.	80 psi	4 hrs	-	1	-	1,20	4
W-9-M-108	9"	Cored concrete masonry; see notes 2, 18, 26, 29, 41; facings on both sides; see note 38	80 psi	3 hrs 30 min	-	1	-	1,20	3 1/2
W-9-M-109	9"	Cored concrete masonry; see notes 3, 19, 23, 27, 40; facing on fire side only; see note 38	80 psi	1 hr 45 min	-	1	-	1,20	1 3/4
W-9-M-110	9"	Cored concrete masonry; see notes 3, 18, 27, 23, 41; facings on one side only; see note 38	80 psi	4 hrs	-	1	-	1,20	4
W-9-M-111	9"	Cored concrete masonry; see notes 3, 18, 26, 34, 41; 2 1/4" brick face on one side only; see note 38	80 psi	5 hrs	-	1	-	1,20	5
W-8-M-112	9"	Cored concrete masonry; see notes 2, 18, 26, 30, 43; facings on both sides; see note 38	80 psi	30 min	-	1	-	1,20	1/2
W-9-M-113	9 1/2"	Cored concrete masonry; see notes 3, 18, 23, 27, 41; facings on both sides; see note 38	80 psi	5 hrs	-	1	-	1,20	5

Table 1.1.4—Notes
Masonry Walls, 8" (200 mm) to less than 10" (250 mm) thick

1. Tested at NBS under ASASpec. No. 42-1934 (ASTM C-19-53).
2. One unit in wall thickness.
3. Two units in wall thickness.
4. Two or three units in wall thickness.
5. Two cells in wall thickness.
6. Three or four cells in wall thickness.
7. Four or five cells in wall thickness.
8. Five or six cells in wall thickness.
9. Minimum % of solid material in units: 40%.
10. Minimum % of solid material in units: 43%.
11. Minimum % of solid material in units: 46%.
12. Minimum % of solid material in units: 48%.
13. Minimum % of solid material in units: 49%.

14. Minimum % of solid material in units: 45%.
15. Minimum % of solid material in units: 51%.
16. Minimum % of solid material in units: 53%.
17. Not less than 5/8" thickness of 1:3 sanded gypsum plaster.
18. Noncombustible or no members framed into wall.
19. Combustible members framed into wall.
20. Load: 80 psi for gross cross-sectional area of wall.
21. Portland cement lime mortar.
22. Failure mode thermal.
23. British test.
24. Passed all criteria.
25. Failed by sudden collapse with no preceding signs of impending failure.
26. One cell in wall thickness.
27. Two cells in wall thickness.
28. Three cells in wall thickness.

Table 1.1.4—Notes, continued

29. Minimum % of solid material in concrete units: 52.
30. Minimum % of solid material in concrete units: 54.
31. Minimum % of solid material in concrete units: 55.
32. Minimum % of solid material in concrete units: 57.
33. Minimum % of solid material in concrete units: 60.
34. Minimum % of solid material in concrete units: 62.
35. Minimum % of solid material in concrete units: 65.
36. Minimum % of solid material in concrete units: 70.
37. Minimum % of solid material in concrete units: 76.
38. Not less than 1/2" of 1:3 sanded gypsum plaster.
39. Three units in wall thickness.
40. Concrete units made with expanded slag or pumice aggregates.
41. Concrete units made with expanded burned clay or shale, crushed limestone, air-cooled slag, or cinders.
42. Concrete units made with calcareous sand and gravel. Coarse aggregate, 60% or more calcite and dolomite.
43. Concrete units made with siliceous sand and gravel. 90% or more quartz, chert, and dolomite.
44. Load: 120 psi for gross cross-sectional area of wall.
45. Load: 160 psi for gross cross-sectional area of wall.

Figure 1.1.5
Masonry Walls, 10" (250 mm) to less than 12" (300 mm) thick

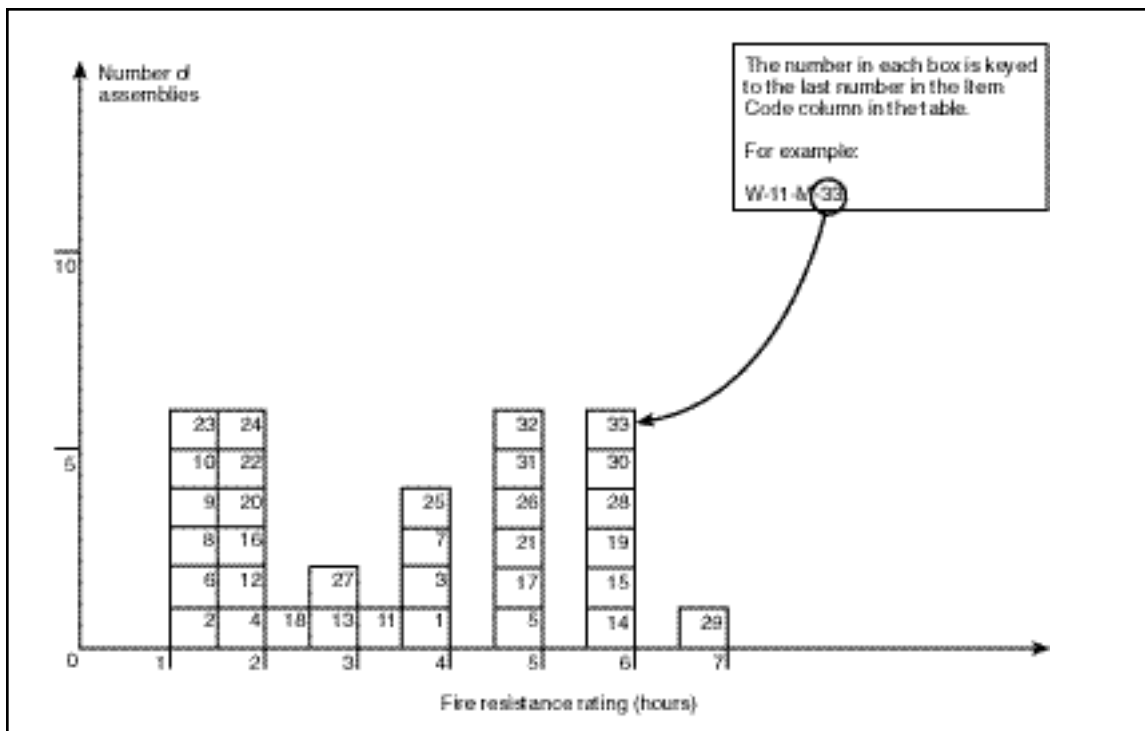

Table 1.1.5
Masonry Walls, 10" (250 mm) to less than 12" (300 mm) thick

Item Code	Thick-ness	Construction Details	Performance		Reference Number			Notes	Rec Hours
			Load	Time	Pre BMS 92	BMS	Post-BMS 92		
W-10-M-1	10"	Core: two, 3 3/4", 40% solid clay or shale structural tiles with 2" air space between; facings: 3/4" portland cement plaster or stucco on both sides	80 psi	4 hrs	-	1	-	1,20	4
W-10-M-2	10"	Core: concrete masonry, 2" air cavity; see notes 3, 19, 27, 34, 40; facings: none	80 psi	1 hr 30 min	-	1	-	1,20	1 1/2
W-10-M-3	10"	Core: concrete masonry; see notes 3, 18, 27, 34, 40; facings: none	80 psi	4 hrs	-	1	-	1,20	4
W-10-M-4	10"	Core: concrete masonry; see notes 2, 19, 26, 33, 40; facings: none	80 psi	2 hrs	-	1	-	1,20	2
W-10-M-5	10"	Cored concrete masonry; see notes 2, 18, 26, 33, 40; no facings	80 psi	5 hrs	-	1	-	1,20	5
W-10-M-6	10"	Cored concrete masonry; see notes 2, 19, 26, 33, 41; no facings	80 psi	1 hr 30 min	-	1	-	1,20	1 1/2
W-10-M-7	10"	Cored concrete masonry; see notes 2, 18, 26, 33, 41; no facings	80 psi	4 hrs	-	1	-	1,20	4
W-10-M-8	10"	Cored concrete masonry (cavity type 2" air space) see notes 3, 19, 27, 34, 42; no facings	80 psi	1 hr 15 min	-	1	-	1,20	1 1/4
W-10-M-9	10"	Cored concrete masonry (cavity type 2" air space); see notes 3, 27, 34, 18, 42; no facings	80 psi	1 hr 15 min	-	1	-	1,20	1 1/4
W-10-M-10	10"	Cored concrete masonry (cavity type 2" air space); see notes 3, 19, 27, 34, 41; no facings	80 psi	1 hr 15 min	-	1	-	1,20	1 1/4
W-10-M-11	10"	Cored concrete masonry (cavity type 2" air space); see notes 3, 18, 27, 34, 41; no facings	80 psi	3 hrs 30 min	-	1	-	1,20	3 1/2
W-10-M-12	10"	9" thick concrete block (11 3/4" x 9" x 4 1/4") with two 2" thick voids included; 3/8" portland cement plaster 1/8" neat gypsum	n/a	1 hr 53 min	-	-	7	23,44	1 3/4
W-10-M-13	10"	Hollow clay tile block wall 8 1/2" block with two 3" voids in each 8 1/2" section; 3/4" gypsum plaster each face	n/a	2 hrs 42 min	-	-	7	23,25	2 1/2
W-10-M-14	10"	2 layers 4 1/4" thick fletton brick (1910 psi); 1 1/2" air space; no ties; sand cement mortar	n/a	6 hrs	-	-	7	23,24	6
W-10-M-15	10"	2 layers 4 1/4" thick fletton brick (1910 psi); 1 1/2" air space; ties—18" O.C. vertical; 3' O.C.—horizontal	n/a	6 hrs	-	-	7	23,24	6
W-10-M-16	10 1/2"	Cored concrete masonry; 2" air cavity; see notes 3, 19, 27, 34, 40; facings: fire side only; see note 38	80 psi	2 hrs	-	1	-	1,20	2

Table 1.1.5, continued (Masonry Walls, 10" to less than 12" thick)

Item Code	Thick-ness	Construction Details	Performance		Reference Number			Notes	Rec Hours
			Load	Time	Pre BMS 92	BMS	Post-BMS 92		
W-10-M-17	10 1/2"	Cored concrete masonry; see notes 3, 18, 27, 34, 40; facings: only side one; see note 38	80 psi	5 hrs	-	1	-	1,20	5
W-10-M-18	10 1/2"	Cored concrete masonry; see notes 2, 19, 26, 33, 40; facings on fire side only; see note 38	80 psi	2 hrs 30 min	-	1	-	1,20	2 1/2
W-10-M-19	10 1/2"	Cored concrete masonry; see notes 2, 18, 26, 33, 40; facings on one side; see note 38	80 psi	6 hrs	-	1	-	1,20	6
W-10-M-20	10 1/2"	Cored concrete masonry; see notes 2, 19, 26, 33, 41; facings on fire side of wall only; see note 38	80 psi	2 hrs	-	1	-	1,20	2
W-10-M-21	10 1/2"	Cored concrete masonry; see notes 2, 18, 26, 33, 41; facings on one side only; see note 38	80 psi	5 hrs	-	1	-	1,20	5
W-10-M-22	10 1/2"	Cored concrete masonry (cavity type 2" air space); see notes 3, 19, 27, 34, 42; facing on fire side only; see note 38	80 psi	1 hr 45 min	-	1	-	1,20	1 3/4
W-10-M-23	10 1/2"	Cored concrete masonry (cavity type 2" air space); see notes 3, 18, 27, 34, 42; facings on one side only; see note 38	80 psi	1 hr 15 min	-	1	-	1,20	1 1/4
W-10-M-24	10 1/2"	Cored concrete masonry (cavity type 2" air space); see notes 3, 19, 27, 34, 41; facings on fire side only; see note 38	80 psi	2 hrs	-	1	-	1,20	2
W-10-M-25	10 1/2"	Cored concrete masonry (cavity type 2" air space); see notes 3, 18, 27, 34, 41; facings on one side only; see note 38	80 psi	4 hrs	-	1	-	1,20	4
W-10-M-26	10 5/8"	Core: 8", 40% solid tile plus 2" furring tile; 5/8" sanded gypsum plaster between tile types; facings on both sides 3/4" portland cement plaster or stucco	80 psi	5 hrs	-	1	-	1,20	5
W-10-M-27	10 5/8"	Core: 8", 40% solid tile plus 2" furring tile; 5/8" sanded gypsum plaster between tile types; facings on one side 3/4" portland cement plaster or stucco	80 psi	3 hrs 30 min	-	1	-	1,20	3 1/2
W-11-M-28	11"	Cored concrete masonry; see notes 3, 18, 27, 34, 40; facings on both sides; see note 38	80 psi	6 hrs	-	1	-	1,20	6
W-11-M-29	11"	Cored concrete masonry; see notes 2, 18, 26, 33, 40; facings on both sides; see note 38	80 psi	7 hrs	-	1	-	1,20	7
W-11-M-30	11"	Cored concrete masonry; see notes 2, 18, 26, 33, 41; facings on both sides of wall; see note 38	80 psi	6 hrs	-	1	-	1,20	6

Table 1.1.5, continued (Masonry Walls, 10" to less than 12" thick)

Item Code	Thick-ness	Construction Details	Performance		Reference Number			Notes	Rec Hours
			Load	Time	Pre BMS 92	BMS	Post-BMS 92		
W-11-M-31	11"	Cored concrete masonry (cavity type 2" air space); see notes 3, 18, 27, 34, 42; facings on both sides; see note 38	80 psi	5 hrs	-	1	-	1,20	5
W-11-M-32	11"	Cored concrete masonry (cavity type 2" air space); see notes 3, 18, 27, 34, 41; facings on both sides; see note 38	80 psi	5 hrs	-	1	-	1,20	5
W-11-M-33	11"	2 layers brick (4 1/2" fletton 2428 psi) 2" air space; Galv. ties 18" O.C. horizontal; 3' O.C. vertical	3 ton/ft	6 hrs	-	-	7	23,24	6

Table 1.1.5—Notes**Masonry Walls, 10" to less than 12" thick**

1. Tested at NBS under ASASpec. No. A2-1934.
2. One unit in wall thickness.
3. Two units in wall thickness.
4. Two or three units in wall thickness.
5. Two cells in wall thickness.
6. Three or four cells in wall thickness.
7. Four or five cells in wall thickness.
8. Five or six cells in wall thickness.
9. Minimum % of solid material in units: 40%.
10. Minimum % of solid material in units: 43%.
11. Minimum % of solid material in units: 46%.
12. Minimum % of solid material in units: 48%.
13. Minimum % of solid material in units: 49%.
14. Minimum % of solid material in units: 45%.
15. Minimum % of solid material in units: 51%.
16. Minimum % of solid material in units: 53%.
17. Not less than 5/8" thickness of 1:3 sanded gypsum plaster.
18. Noncombustible or no members framed into wall.
19. Combustible members framed into wall.
20. Load: 80 psi for gross cross-sectional area.
21. Portland cement-lime mortar.
22. Failure mode—thermal.
23. British test.
24. Passed all criteria.
25. Failed by sudden collapse with no preceding signs of impending failure.
26. One cell in wall thickness.
27. Two cells in wall thickness.
28. Three cells in wall thickness.
29. Minimum % of solid material in concrete units: 52%.
30. Minimum % of solid material in concrete units: 54%.
31. Minimum % of solid material in concrete units: 55%.
32. Minimum % of solid material in concrete units: 57%.
33. Minimum % of solid material in concrete units: 60%.
34. Minimum % of solid material in concrete units: 62%.
35. Minimum % of solid material in concrete units: 65%.
36. Minimum % of solid material in concrete units: 70%.
37. Minimum % of solid material in concrete units: 76%.
38. Not less than 1/2" of 1:3 sanded gypsum plaster.
39. Three units in wall thickness.
40. Concrete units made with expanded slag or pumice aggregates.
41. Concrete units made with expanded burned clay or shale, crushed limestone, air-cooled slag, or cinders.
42. Concrete units made with calcareous sand and gravel. Coarse aggregate, 60% or more calcite and dolomite.

Figure 1.1.6
Masonry Walls, 12" (300 mm) to less than 14" (350 mm) thick

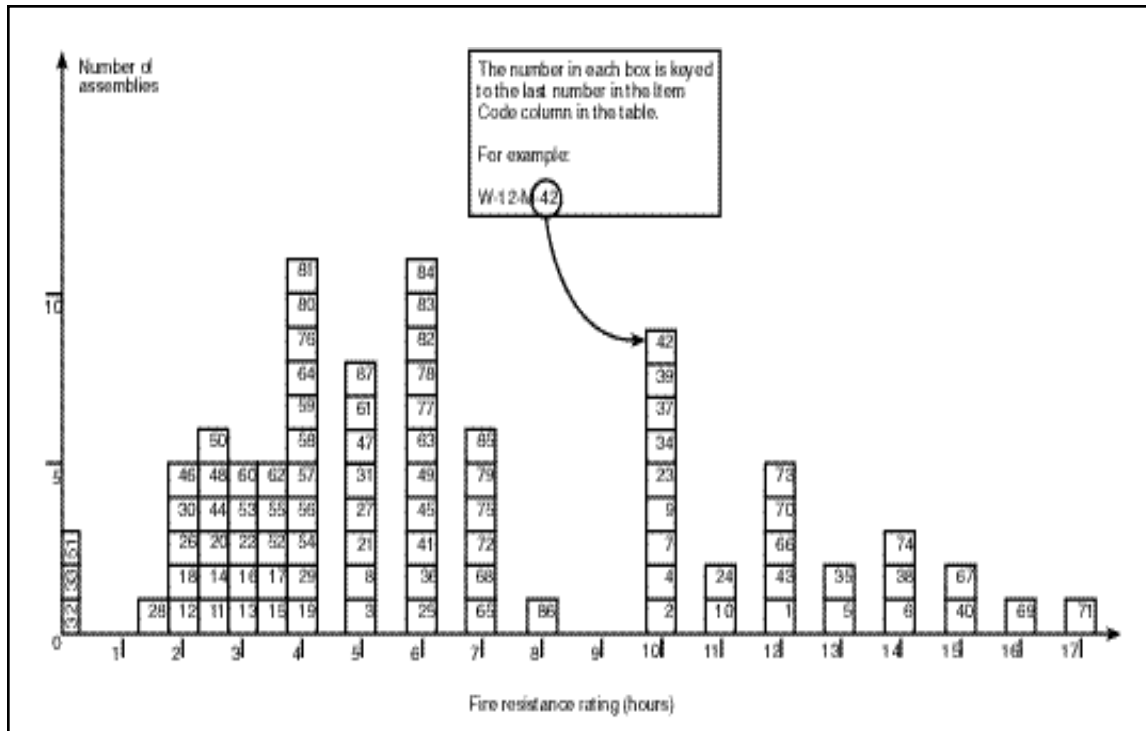

Table 1.1.6
Masonry Walls 12" (300 mm) to less than 14" (350 mm) thick

Item Code	Thick-ness	Construction Details	Performance		Reference Number			Notes	Rec Hours
			Load	Time	Pre BMS 92	BMS	Post-BMS 92		
W-12-M-1	12"	Core: solid clay or shale brick; no facings	n/a	12 hrs	-	1	-	1	12
W-12-M-2	12"	Core: solid clay or shale brick; no facings	160 psi	10 hrs	-	1	-	1,44	10
W-12-M-3	12"	Core: hollow rolok of clay or shale; no facings	160 psi	5 hrs	-	1	-	1,44	5
W-12-M-4	12"	Core: hollow rolok bak of clay or shale; no facings	160 psi	10 hrs	-	1	-	1,44	10
W-12-M-5	12"	Core: concrete brick; no facings	160 psi	13 hrs	-	1	-	1,44	13
W-12-M-6	12"	Core: sand-lime brick; no facings	n/a	14 hrs	-	1	-	1	14
W-12-M-7	12"	Core: sand-lime brick; no facings	160 psi	10 hrs	-	1	-	1,44	10
W-12-M-8	12"	Cored clay or shale bricks; units in wall thickness: 1; cells in wall thickness: 2; minimum % solids: 70; no facings	120 psi	5 hrs	-	1	-	1,45	5

Table 1.1.6, continued (Masonry Walls, 12" to less than 14" thick)

Item Code	Thick-ness	Construction Details	Performance		Reference Number			Notes	Rec Hours
			Load	Time	Pre BMS 92	BMS	Post-BMS 92		
W-12-M-9	12"	Cored clay or shale bricks; units in wall thickness: 3; cells in wall thickness: 3; minimum % solids: 87; no facings	160 psi	10 hrs	-	1	-	1,44	10
W-12-M-10	12"	Cored clay or shale bricks; units in wall thickness: 3; cells in wall thickness: 3; minimum % solids: 87; no facings	n/a	11 hrs	-	1	-	1	11
W-12-M-11	12"	Core: clay or shale structural tile; see notes 2, 6, 9, 18; no facings	80 psi	2 hrs 30 min	-	1	-	1,20	2 1/2
W-12-M-12	12"	Core: clay or shale structural tile; see notes 2, 4, 9, 19; no facings	80 psi	2 hrs	-	1	-	1,20	2
W-12-M-13	12"	Core: clay or shale structural tile; see notes 2, 6, 14, 19; no facings	80 psi	3 hrs	-	1	-	1,20	3
W-12-M-14	12"	Core: clay or shale structural tile; see notes 2, 6, 14, 18; no facings	80 psi	2 hrs 30 min	-	1	-	1,20	2 1/2
W-12-M-15	12"	Core: clay or shale structural tile; see notes 2, 4, 13, 18; no facings	80 psi	3 hrs 30 min	-	1	-	1,20	3 1/2
W-12-M-16	12"	Core: clay or shale structural tile; see notes 2, 4, 13, 19; no facings	80 psi	3 hrs	-	1	-	1,20	3
W-12-M-17	12"	Core: clay or shale structural tile; see notes 3, 6, 9, 18; no facings	80 psi	3 hrs 30 min	-	1	-	1,20	3 1/2
W-12-M-18	12"	Core: clay or shale structural tile; see notes 3, 6, 9, 19; no facings	80 psi	2 hrs	-	1	-	1,20	2
W-12-M-19	12"	Core: clay or shale structural tile; see notes 3, 6, 14, 18; no facings	80 psi	4 hrs	-	1	-	1,20	4
W-12-M-20	12"	Core: clay or shale structural tile; see notes 3, 6, 14, 19; no facings	80 psi	2 hrs 30 min	-	1	-	1,20	2 1/2
W-12-M-21	12"	Core: clay or shale structural tile; see notes 3, 6, 16, 18; no facings	80 psi	5 hrs	-	1	-	1,20	5
W-12-M-22	12"	Core: clay or shale structural tile; see notes 3, 6, 16, 19; no facings	80 psi	3 hrs	-	1	-	1,20	3
W-12-M-23	12"	Core: 8", 70% solid clay or shale structural tile; 4" brick facing on one side	80 psi	10 hrs	-	1	-	1,20	10
W-12-M-24	12"	Core: 8", 70% solid clay or shale structural tile; 4" brick facing on one side	n/a	11 hrs	-	1	-	1	11
W-12-M-25	12"	Core: 8", 40% solid clay or shale structural tile; 4" brick facing on one side	80 psi	6 hrs	-	1	-	1,20	6
W-12-M-26	12"	Cored concrete masonry; see notes 1, 9, 15, 16, 20; no facings	80 psi	2 hrs	-	1	-	1,20	2
W-12-M-27	12"	Cored concrete masonry; see notes 2, 18, 26, 34, 41; no facings	80 psi	5 hrs	-	1	-	1,20	5
W-12-M-28	12"	Cored concrete masonry; see notes 2, 19, 26, 31, 41; no facings	80 psi	1 hr 30 min	-	1	-	1,20	1 1/2

Table 1.1.6, continued (Masonry Walls, 12" to less than 14" thick)

Item Code	Thick-ness	Construction Details	Performance		Reference Number			Notes	Rec Hours
			Load	Time	Pre BMS 92	BMS	Post-BMS 92		
W-12-M-29	12"	Cored concrete masonry; see notes 2, 18, 26, 31, 41; no facings	80 psi	4 hrs	-	1	-	1,20	4
W-12-M-30	12"	Cored concrete masonry; see notes 3, 19, 27, 31, 43; no facings	80 psi	2 hrs	-	1	-	1,20	2
W-12-M-31	12"	Cored concrete masonry; see notes 3, 18, 27, 31, 43; no facings	80 psi	5 hrs	-	1	-	1,20	5
W-12-M-32	12"	Cored concrete masonry; see notes 2, 19, 26, 32, 43; no facings	80 psi	25 min	-	1	-	1,20	1/3
W-12-M-33	12"	Cored concrete masonry; see notes 2, 18, 26, 32, 43; no facings	80 psi	25 min	-	1	-	1,20	1/3
W-12-M-34	12 1/2"	Core: solid clay or shale brick; 1/2" of 1:3 sanded gypsum plaster facing on one side	160 psi	10 hrs	-	1	-	1,44	10
W-12-M-35	12 1/2"	Core: solid clay or shale brick; 1/2" of 1:3 sanded gypsum plaster facing on one side	n/a	13 hrs	-	1	-	1	13
W-12-M-36	12 1/2"	Core: hollow rolok of clay or shale; 1/2" of 1:3 sanded gypsum plaster facing on one side	160 psi	6 hrs	-	1	-	1,44	6
W-12-M-37	12 1/2"	Core: hollow rolok bak of clay or shale; 1/2" of 1:3 sanded gypsum plaster facing on one side	160 psi	10 hrs	-	1	-	1,44	10
W-12-M-38	12 1/2"	Core: concrete; 1/2" of 1:3 sanded gypsum plaster facing on one side	160 psi	14 hrs	-	1	-	1,44	14
W-12-M-39	12 1/2"	Core: sand-lime brick; 1/2" of 1:3 sanded gypsum plaster facing on one side	160 psi	10 hrs	-	1	-	1,44	10
W-12-M-40	12 1/2"	Core: sand-lime brick; 1/2" of 1:3 sanded gypsum plaster facing on one side	n/a	15 hrs	-	1	-	1	15
W-12-M-41	12 1/2"	Units in wall thickness: 1; cells in wall thickness: 2; minimum % solids: 70; cored clay or shale brick; 1/2" of 1:3 sanded gypsum plaster facing on one side	120 psi	6 hrs	-	1	-	1,45	6
W-12-M-42	12 1/2"	Cored clay or shale bricks; units in wall thickness: 3; cells in wall thickness: 3; minimum % solids: 87; 1/2" of 1:3 sanded gypsum plaster facings on one side	160 psi	10 hrs	-	1	-	1,44	10
W-12-M-43	12 1/2"	Cored clay or shale bricks; units in wall thickness: 3; cells in wall thickness: 3; minimum % solids: 87; 1/2" of 1:3 sanded gypsum plaster facing on one side	n/a	12 hrs	-	1	-	1	12
W-12-M-44	12 1/2"	Cored concrete masonry; see notes 2, 19, 26, 34, 41; facing on fire side only; see note 38	80 psi	2 hrs 30 min	-	1	-	1,20	2 1/2

Table 1.1.6, continued (Masonry Walls, 12" to less than 14" thick)

Item Code	Thick-ness	Construction Details	Performance		Reference Number			Notes	Rec Hours
			Load	Time	Pre BMS 92	BMS	Post-BMS 92		
W-12-M-45	12 1/2"	Cored concrete masonry; see notes 2, 18, 26, 34, 39, 41; facing on one side only; see note 38	80 psi	6 hrs	-	1	-	1,20	6
W-12-M-46	12 1/2"	Cored concrete masonry; see notes 2, 19, 26, 34, 41; facing on fire side only; see note 38	80 psi	2 hrs	-	1	-	1,20	2
W-12-M-47	12 1/2"	Cored concrete masonry; see notes 2, 18, 26, 31, 41; facings one side of wall only; see note 38	80 psi	5 hrs	-	1	-	1,20	5
W-12-M-48	12 1/2"	Cored concrete masonry; see notes 3, 19, 27, 31, 43; facing on fire side only; see note 38	80 psi	2 hrs 30 min	-	1	-	1,20	2 1/2
W-12-M-49	12 1/2"	Cored concrete masonry; see notes 3, 18, 27, 31, 43; facing one side only; see note 38	80 psi	6 hrs	-	1	-	1,20	6
W-12-M-50	12 1/2"	Cored concrete masonry; see notes 2, 19, 26, 32, 43; facing on fire side only; see note 38	80 psi	2 hrs 30 min	-	1	-	1,20	2 1/2
W-12-M-51	12 1/2"	Cored concrete masonry; see notes 2, 18, 26, 32, 43; facing one side only; see note 38	80 psi	25 min	-	1	-	1,20	1/3
W-12-M-52	12 5/8"	Clay or shale structural tile; see notes 2, 6, 9, 18; facing: side 1—see note 17; side 2—none	80 psi	3 hrs 30 min	-	1	-	1,20	3 1/2
W-12-M-53	12 5/8"	Clay or shale structural tile; see notes 2, 6, 9, 19; facing on fire side only; see note 17	80 psi	3 hrs	-	1	-	1,20	3
W-12-M-54	12 5/8"	Clay or shale structural tile; see notes 2, 6, 14, 19; facing: side 1—see note 17; side 2—none	80 psi	4 hrs	-	1	-	1,20	4
W-12-M-55	12 5/8"	Clay or shale structural tile; see notes 2, 6, 14, 18; facings on exposed side only; see note 17	80 psi	3 hrs 30 min	-	1	-	1,20	3 1/2
W-12-M-56	12 5/8"	Clay or shale structural tile; see notes 2, 4, 13, 18; facings: side 1—see note 17; side 2—none	80 psi	4 hrs	-	1	-	1,20	4
W-12-M-57	12 5/8"	Clay or shale structural tile; see notes 1, 4, 13, 19; facings on fire side only; see note 17	80 psi	4 hrs	-	1	-	1,20	4
W-12-M-58	12 5/8"	Clay or shale structural tile; see notes 3, 6, 9, 18; facings: side 1—see note 17; side 2—none	80 psi	4 hrs	-	1	-	1,20	4
W-12-M-59	12 5/8"	Clay or shale structural tile; see notes 3, 6, 9, 19; facings on fire side only; see note 17	80 psi	3 hrs	-	1	-	1,20	3
W-12-M-60	12 5/8"	Clay or shale structural tile; see notes 3, 6, 14, 18; facings: side 1—see note 17; side 2—none	80 psi	5 hrs	-	1	-	1,20	5

Table 1.1.6, continued (Masonry walls, 12" to less than 14" thick)

Item Code	Thick-ness	Construction Details	Performance		Reference Number			Notes	Rec Hours
			Load	Time	Pre BMS 92	BMS	Post-BMS 92		
W-12-M-61	12 5/8"	Clay or shale structural tile; see notes 3, 6, 14, 19; facings: fire side only; see note 17	80 psi	3 hrs 30 min	-	1	-	1,20	3 1/2
W-12-M-62	12 5/8"	Clay or shale structural tile; see notes 3, 6, 16, 18; facings: side 1—see note 17; side 2—none	80 psi	6 hrs	-	1	-	1,20	6
W-12-M-63	12 5/8"	Clay or shale structural tile; see notes 3, 6, 16, 19; facing fire side only; see note 17	80 psi	4 hrs	-	1	-	1,20	4
W-12-M-64	12 5/8"	Core: 8", 40% solid clay or shale structural tile; facings 4" brick plus 5/8" of 1:3 sanded gypsum plaster on one side	80 psi	7 hrs	-	1	-	1,20	7
W-13-M-65	13"	Core:solid clay or shale brick; 1/2" of 1:3 sanded gypsum plaster facing on both sides	160 psi	12 hrs	-	1	-	1,44	12
W-13-M-66	13"	Core: solid clay or shale brick; 1/2" of 1:3 sanded gypsum plaster facing on both sides	n/a	15 hrs	-	1	-	1,20	15
W-13-M-67	13"	Core: solid clay or shale brick; 1/2" of 1:3 sanded gypsum plaster facings on both sides	n/a	15 hrs	-	1	-	1	15
W-13-M-68	13"	Core: hollow rolok of clay or shale; 1/2" of 1:3 sanded gypsum plaster facings on both sides	80 psi	7 hrs	-	1	-	1,20	7
W-13-M-69	13"	Core: concrete brick; 1/2" of 1:3 sanded gypsum plaster facings on both sides	160 psi	16 hrs	-	1	-	1,44	16
W-13-M-70	13"	Core: sand-lime brick; 1/2" of 1:3 sanded gypsum plaster facings on both sides	160 psi	12 hrs	-	1	-	1,44	12
W-13-M-71	13"	Core: sand-lime brick; 1/2" of 1:3 sanded gypsum plaster facings on both sides	n/a	17 hrs	-	1	-	1	17
W-13-M-72	13"	Cored clay or shale bricks; units in wall thickness: 1; cells in wall thickness: 2; minimum % solids: 70; 1/2" of 1:3 sanded gypsum plaster facings on both sides	120 psi	7 hrs	-	1	-	1,45	7
W-13-M-73	13"	Cored clay or shale bricks; units in wall thickness: 3; cells in wall thickness: 3; minimum % solids: 87; 1/2" of 1:3 sanded gypsum plaster facings on both sides	160 psi	12 hrs	-	1	-	1,44	12
W-13-M-74	13"	Cored clay or shale bricks; units in wall thickness: 3; cells in wall thickness: 2; minimum % solids: 87; 1/2" of 1:3 sanded gypsum plaster facings on both sides	n/a	14 hrs	-	1	-	1	14

Table 1.1.6, continued (Masonry Walls, 12" to less than 14" thick)

Item Code	Thick-ness	Construction Details	Performance		Reference Number			Notes	Rec Hours
			Load	Time	Pre BMS 92	BMS	Post-BMS 92		
W-13-M-75	13"	Cored concrete masonry; see notes 18, 23, 28, 39, 41; no facings	80 psi	7 hrs	-	1	-	1,20	7
W-13-M-76	13"	Cored concrete masonry; see notes 19, 23, 28, 39, 41; no facings	80 psi	4 hrs	-	1	-	1,20	4
W-13-M-77	13"	Cored concrete masonry; see notes 3, 18, 27, 31, 43; facings on both sides; see note 38	80 psi	6 hrs	-	1	-	1,20	6
W-13-M-78	13"	Cored concrete masonry; see notes 2, 18, 26, 31, 41; facings on both sides; see note 38	80 psi	6 hrs	-	1	-	1,20	6
W-13-M-79	13"	Cored concrete masonry; see notes 2, 18, 26, 34, 41; facings on both sides of wall; see note 38	80 psi	7 hrs	-	1	-	1,20	7
W-13-M-80	13 1/4"	Core: clay or shale structural tile; see notes 2, 6, 9, 18; facings: see note 17 for both sides	80 psi	4 hrs	-	1	-	1,20	4
W-13-M-81	13 1/4"	Core: clay or shale structural tile; see notes 2, 6, 14, 19; facings: see note 17 for both sides	80 psi	4 hrs	-	1	-	1,20	4
W-13-M-82	13 1/4"	Core: clay or shale structural tile; see notes 2, 4, 13, 18; facings: see note 17 for both sides	80 psi	6 hrs	-	1	-	1,20	6
W-13-M-83	13 1/4"	Core: clay or shale structural tile; see notes 3, 6, 9, 18; facings: see note 17 for both sides	80 psi	6 hrs	-	1	-	1,20	6
W-13-M-84	13 1/4"	Core: clay or shale structural tile; see notes 3, 6, 14, 18; facings: see note 17 for both sides	80 psi	6 hrs	-	1	-	1,20	6
W-13-M-85	13 1/4"	Core: clay or shale structural tile; see notes 3, 6, 16, 18; facings: see note 17 for both sides	80 psi	7 hrs	-	1	-	1,20	7
W-13-M-86	13 1/2"	Cored concrete masonry; see notes 18, 23, 28, 39, 41; facing on one side only; see note 38	80 psi	8 hrs	-	1	-	1,20	8
W-13-M-87	13 1/2"	Cored concrete masonry; see notes 19, 23, 28, 39, 41; facing on fire side only; see note 38	80 psi	5 hrs	-	1	-	1,20	5

Table 1.1.6—Notes**Masonry Walls, 12" to less than 14" thick**

1. Tested at NBS under ASASpec. No. A2-1934.
2. One unit in wall thickness.
3. Two units in wall thickness.
4. Two or three units in wall thickness.
5. Two cells in wall thickness.
6. Three or four cells in wall thickness.

7. Four or five cells in wall thickness.
8. Five or six cells in wall thickness.
9. Minimum % of solid materials in units: 40%.
10. Minimum % of solid materials in units: 43%.
11. Minimum % of solid materials in units: 46%.
12. Minimum % of solid materials in units: 48%.
13. Minimum % of solid materials in units: 49%.

Table 1.1.6—Notes, continued

- 14. Minimum % of solid materials in units: 45%.
- 15. Minimum % of solid materials in units: 51%.
- 16. Minimum % of solid materials in units: 53%.
- 17. Not less than 5/8" thickness of 1:3 sanded gypsum plaster.
- 18. Noncombustible or no members framed into wall.
- 19. Combustible members framed into wall.
- 20. Load: 80 psi for gross area.
- 21. Portland cement-lime mortar.
- 22. Failure mode—thermal.
- 23. British test.
- 24. Passed all criteria.
- 25. Failed by sudden collapse with no preceding signs of impending failure.
- 26. One cell in wall thickness.
- 27. Two cells in wall thickness.
- 28. Three cells in wall thickness.
- 29. Minimum % of solid material in concrete units: 52%.
- 30. Minimum % of solid material in concrete units: 54%.
- 31. Minimum % of solid material in concrete units: 55%.
- 32. Minimum % of solid material in concrete units: 57%.
- 33. Minimum % of solid material in concrete units: 60%.
- 34. Minimum % of solid material in concrete units: 62%.
- 35. Minimum % of solid material in concrete units: 65%.
- 36. Minimum % of solid material in concrete units: 70%.
- 37. Minimum % of solid material in concrete units: 76%.
- 38. Not less than 1/2" of 1:3 sanded gypsum plaster.
- 39. Three units in wall thickness.
- 40. Concrete units made with expanded slag or pumice aggregates.
- 41. Concrete units made with expanded burned clay or shale, crushed limestone, air-cooled slag, or cinders.
- 42. Concrete units made with calcareous sand and gravel. Coarse aggregate, 60% or more calcite and dolomite.
- 43. Concrete units made with siliceous sand and gravel. 90% or more quartz, chert, or flint.
- 44. Load: 160 psi of gross wall cross-sectional area.
- 45. Load: 120 psi of gross wall cross-sectional area.

Figure 1.1.7
Masonry Walls 14" (350 mm) or more thick

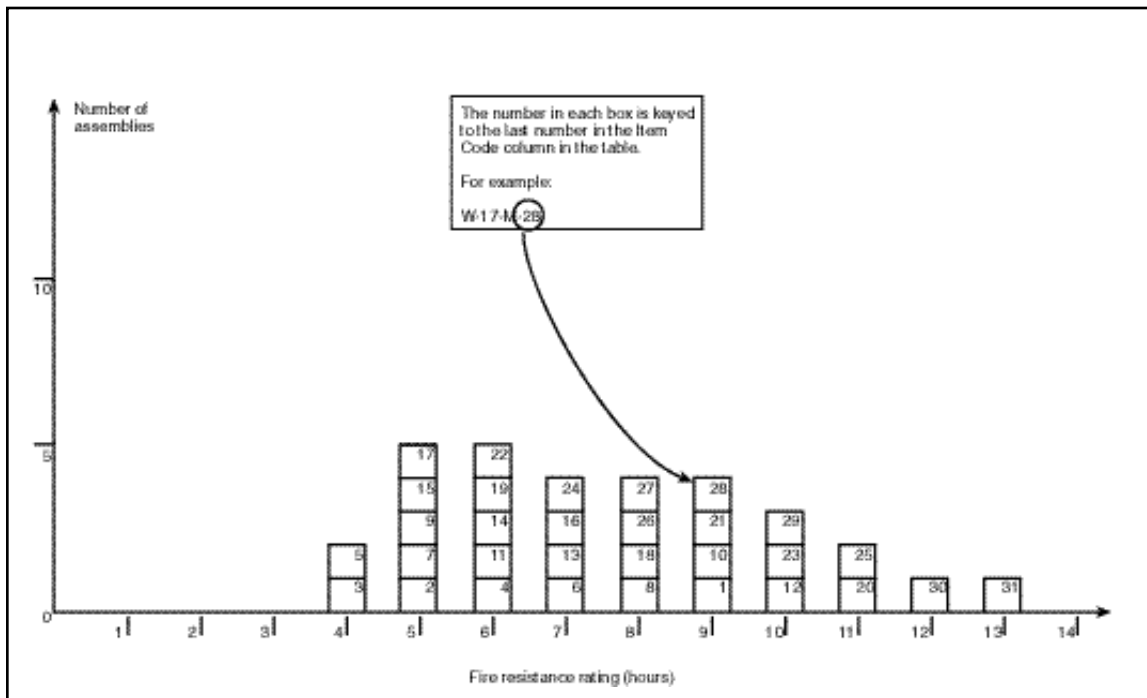

Table 1.1.7
Masonry Walls, 14" (350 mm) or more thick

Item Code	Thick-ness	Construction Details	Performance		Reference Number			Notes	Rec Hours
			Load	Time	Pre BMS 92	BMS	Post-BMS 92		
W-14-M-1	14"	Core: cored concrete masonry; see notes 18, 28, 35, 39, 41; facings: both sides; see note 38	80 psi	9 hrs	-	1	-	1,20	9
W-16-M-2	16"	Core: clay or shale structural tile; see notes 4, 7, 9, 19; no facings	80 psi	5 hrs	-	1	-	1,20	5
W-16-M-3	16"	Core: clay or shale structural tile; see notes 4, 7, 9, 19; no facings	80 psi	4 hrs	-	1	-	1,20	4
W-16-M-4	16"	Core: clay or shale structural tile; see notes 4, 7, 10, 18; no facings	80 psi	6 hrs	-	1	-	1,20	6
W-16-M-5	16"	Core: clay or shale structural tile; see notes 4, 7, 10, 19; no facings	80 psi	4 hrs	-	1	-	1,20	4
W-16-M-6	16"	Core: clay or shale structural tile; see notes 4, 7, 11, 18; no facings	80 psi	7 hrs	-	1	-	1,20	7
W-16-M-7	16"	Core: clay or shale structural tile; see notes 4, 7, 11, 19; no facings	80 psi	5 hrs	-	1	-	1,20	5
W-16-M-8	16"	Core: clay or shale structural tile; see notes 4, 8, 13, 18; no facings	80 psi	8 hrs	-	1	-	1,20	8
W-16-M-9	16"	Core: clay or shale structural tile; see notes 4, 8, 13, 19; no facings	80 psi	5 hrs	-	1	-	1,20	5
W-16-M-10	16"	Clay or shale structural tile core; see notes 4, 8, 15, 18; no facings	80 psi	9 hrs	-	1	-	1,20	9
W-16-M-11	16"	Clay or shale structural tile core; see notes 3, 7, 14, 18; no facings	80 psi	6 hrs	-	1	-	1,20	6
W-16-M-12	16"	Clay or shale structural tile core; see notes 4, 8, 16, 18; no facings	80 psi	10 hrs	-	1	-	1,20	10
W-16-M-13	16"	Clay or shale structural tile core; see notes 4, 6, 16, 19; no facings	80 psi	7 hrs	-	1	-	1,20	7
W-16-M-14	16 5/8"	Clay or shale structural tile core; see notes 4, 7, 9, 18; facings: side 1—see note 17; side 2—none	80 psi	6 hrs	-	1	-	1,20	6
W-16-M-15	16 5/8"	Clay or shale structural tile core; see notes 4, 7, 9, 19; facings: fire side only; see note 17	80 psi	5 hrs	-	1	-	1,20	5
W-16-M-16	16 5/8"	Clay or shale structural tile core; see notes 4, 7, 10, 18; facings: side 1—see note 17; side 2—none	80 psi	7 hrs	-	1	-	1,20	7
W-16-M-17	16 5/8"	Clay or shale structural tile core; see notes 4, 7, 10, 19; facings: fire side only; see note 17	80 psi	5 hrs	-	1	-	1,20	5
W-16-M-18	16 5/8"	Clay or shale structural tile core; see notes 4, 7, 11, 18; facings: side 1—see note 17; side 2—none	80 psi	8 hrs	-	1	-	1,20	8

Table 1.1.7, continued (Masonry Walls, 14" or more thick)

Item Code	Thick-ness	Construction Details	Performance		Reference Number			Notes	Rec Hours
			Load	Time	Pre BMS 92	BMS	Post-BMS 92		
W-16-M-19	16 5/8"	Clay or shale structural tile core; see notes 4, 7, 11, 19; facings: fire side only; see note 17	80 psi	6 hrs	-	1	-	1,20	6
W-16-M-20	16 5/8"	Clay or shale structural tile core; see notes 4, 8, 13, 18; facings: side 1—see note 17; side 2—same as side 1	80 psi	11 hrs	-	1	-	1,20	11
W-16-M-21	16 5/8"	Clay or shale structural tile core; see notes 4, 8, 13, 18; facings: side 1—see note 17; side-2 none	80 psi	9 hrs	-	1	-	1,20	9
W-16-M-22	16 5/8"	Clay or shale structural tile core; see notes 4, 8, 13, 19; facings: fire side only; see note 17	80 psi	6 hrs	-	1	-	1,20	6
W-16-M-23	16 5/8"	Clay or shale structural tile core; see notes 4, 8, 15, 18; facings: side 1—see note 17; side 2—none	80 psi	10 hrs	-	1	-	1,20	10
W-16-M-24	16 5/8"	Clay or shale structural tile core; see notes 4, 8, 15, 19; facings: fire side only; see note 17	80 psi	7 hrs	-	1	-	1,20	7
W-16-M-25	16 5/8"	Clay or shale structural tile core; see notes 4, 6, 16, 18; facings: side 1—see note 17; side 2—none	80 psi	11 hrs	-	1	-	1,20	11
W-16-M-26	16 5/8"	Clay or shale structural tile core; see notes 4, 6, 16, 19; facings: fire side only; see note 17	80 psi	8 hrs	-	1	-	1,20	8
W-17-M-27	17 1/4"	Clay or shale structural tile core; see notes 4, 7, 9, 18; facings: side 1 and 2 see note 17	80 psi	8 hrs	-	1	-	1,20	8
W-17-M-28	17 1/4"	Clay or shale structural tile core; see notes 4, 7, 10, 18; facings: side 1 and 2 see note 17	80 psi	9 hrs	-	1	-	1,20	9
W-17-M-29	17 1/4"	Clay or shale structural tile core; see notes 4, 7, 11, 18; facings: side 1 and 2 see note 17	80 psi	10 hrs	-	1	-	1,20	10
W-17-M-30	17 1/4"	Clay or shale structural tile core; see notes 4, 8, 15, 18; facings: side 1 and 2 see note 17	80 psi	12 hrs	-	1	-	1,20	12
W-17-M-31	17 1/4"	Clay or shale restructural tile core; see notes 4,5,16,18; facings: side 1 and 2 see note 17	80 psi	13 hrs	-	1	-	1,20	13

Table 1.1.7—Notes
Masonry Walls, 14" or more thick

1. Tested at NBS under ASASpec. No. A2-1934.
2. One unit in wall thickness.
3. Two units in wall thickness.
4. Two or three units in wall thickness.
5. Two cells in wall thickness.
6. Three or four cells in wall thickness.
7. Four or five cells in wall thickness.
8. Five or six cells in wall thickness.
9. Minimum % of solid materials in units: 40%.
10. Minimum % of solid materials in units: 43%.

Table 1.1.7—Notes, continued

- 11. Minimum % of solid materials in units: 46%.
- 12. Minimum % of solid materials in units: 48%.
- 13. Minimum % of solid materials in units: 49%.
- 14. Minimum % of solid materials in units: 45%.
- 15. Minimum % of solid materials in units: 51%.
- 16. Minimum % of solid materials in units: 53%.
- 17. Not less than 5/8" thickness of 1:3 sanded gypsum plaster.
- 18. Noncombustible or no members framed into wall.
- 19. Combustible members framed into wall.
- 20. Load: 80 psi for gross area.
- 21. Portland cement-lime mortar.
- 22. Failure mode—thermal.
- 23. British test.
- 24. Passed all criteria.
- 25. Failed by sudden collapse with no preceding signs of impending failure.
- 26. One cell in wall thickness.
- 27. Two cells in wall thickness.
- 28. Three cells in wall thickness.
- 29. Minimum % of solid material in concrete units: 52%.
- 30. Minimum % of solid material in concrete units: 54%.
- 31. Minimum % of solid material in concrete units: 55%.
- 32. Minimum % of solid material in concrete units: 57%.
- 33. Minimum % of solid material in concrete units: 60%.
- 34. Minimum % of solid material in concrete units: 62%.
- 35. Minimum % of solid material in concrete units: 65%.
- 36. Minimum % of solid material in concrete units: 70%.
- 37. Minimum % of solid material in concrete units: 76%.
- 38. Not less than 1/2" of 1:3 sanded gypsum plaster.
- 39. Three units in wall thickness.
- 40. Concrete units made with expanded slag or pumice aggregates.
- 41. Concrete units made with expanded burned clay or shale, crushed limestone, air-cooled slag or cinders.
- 42. Concrete units made with calcareous sand and gravel. Coarse aggregate, 60% or more calcite and dolomite.
- 43. Concrete units made with siliceous sand and gravel. 90% or more quartz, chert, or flint.

Figure 1.2.1
Metal Frame Walls, 0" (0 mm) to less than 4" (100 mm) thick

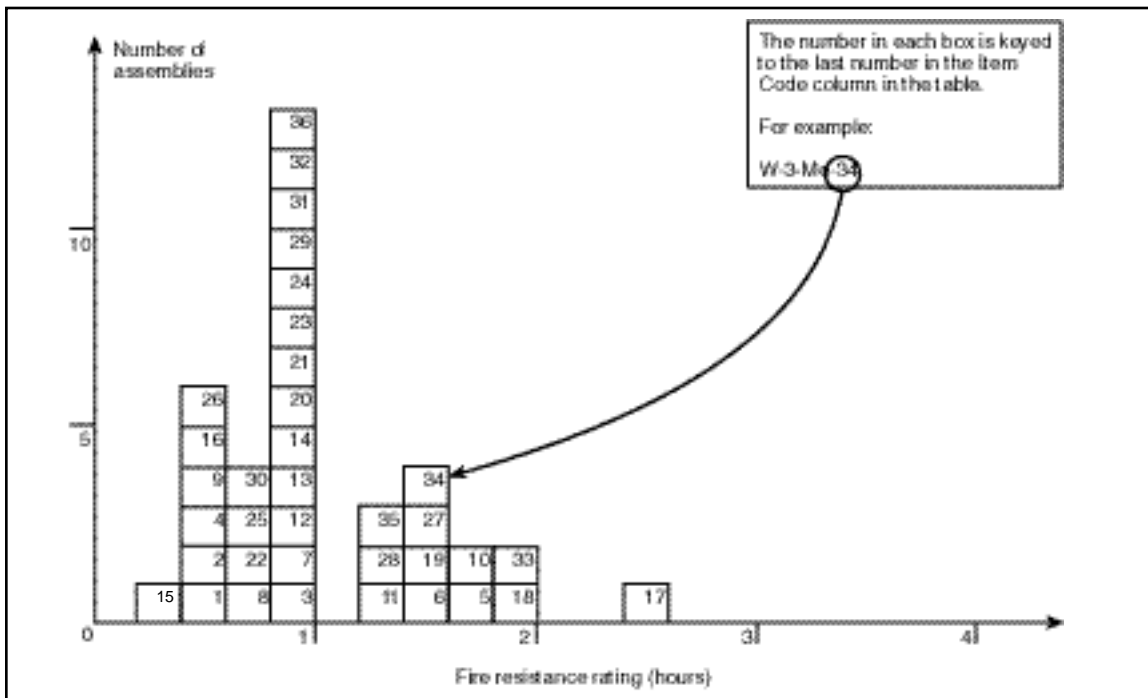

Table 1.2.1
Metal Frame Walls, 0" (0 mm) to less than 4" (100 mm) thick

Item Code	Thick-ness	Construction Details	Performance		Reference Number			Notes	Rec Hours
			Load	Time	Pre BMS 92	BMS	Post-BMS 92		
W-3-Me-1	3"	Core: steel channels having 3 rows of 4" x 1/8" staggered slots in web; core filled with heat expanded vermiculite weighing 1.5 lb/ft ² of wall area; facings: sides 1 and 2—18 gauge steel, spot welded to core	n/a	25 min	-	1	-	-	1/3
W-3-Me-2	3"	Core: steel channels having 3 rows of 4" x 1/8" staggered slots in web; core filled with heat expanded vermiculite weighing 2 lb/ft ² of wall area; facings: sides 1 and 2—18 gauge steel, spot welded to core	n/a	30 min	-	1	-	-	1/2
W-2-Me-3	2 1/2"	Solid partition—3/8" tension rods (vertical) 3' O.C. with metal lath; scratch coat—cement/sand/lime/plaster; float coats—cement/sand/lime plaster; finish coats—neat gypsum plaster	n/a	1 hr	-	-	7	1	1
W-2-Me-4	2"	Solid wall: steel channel per note 1, 2" thickness of 1:2, 1:3 portland cement on metal lath	n/a	30 min	-	1	-	-	1/2
W-2-Me-5	2"	Solid wall: steel channel per note 1, 2" thickness of neat gypsum plaster on metal lath	n/a	1 hr 45 min	-	1	-	-	1 3/4
W-2-Me-6	2"	Solid wall: steel channel per note 1, 2" thickness of 1: 1/2, 1: 1/2 gypsum plaster on metal lath	n/a	1 hr 30 min	-	1	-	-	1 1/2
W-2-Me-7	2"	Solid wall: steel channel per note 2, 2" thickness of 1:1, 1:1 gypsum plaster on metal lath	n/a	1 hr	-	1	-	-	1
W-2-Me-8	2"	Solid wall: steel channel per note 1, 2" thickness of 1:2, 1:2 gypsum plaster on metal lath	n/a	45 min	-	1	-	-	3/4
W-2-Me-9	2 1/4"	Solid wall: steel channel per note 2, 2 1/4" thickness of 1:2, 1:3 portland cement on metal lath	n/a	30 min	-	1	-	-	1/2
W-2-Me-10	2 1/4"	Solid wall: steel channel per note 2, 2 1/4" thickness of neat gypsum plaster on metal lath	n/a	2 hrs	-	1	-	-	2
W-2-Me-11	2 1/4"	Solid wall: steel channel per note 2, 2 1/4" thickness of 1: 1/2, 1: 1/2 gypsum plaster on metal lath	n/a	1 hr 45 min	-	1	-	-	1 3/4
W-2-Me-12	2 1/4"	Solid wall: steel channel per note 2, 2 1/4" thickness of 1:1, 1:1 gypsum plaster on metal lath	n/a	1 hr 15 min	-	1	-	-	1 1/4
W-2-Me-13	2 1/4"	Solid wall: steel channel per note 2, 2 1/4" thickness of 1:2, 1:2 gypsum plaster on metal lath	n/a	1 hr	-	1	-	-	1

Table 1.2.1, continued (Metal Frame Walls, 0" to less than 4" thick)

Item Code	Thick-ness	Construction Details	Performance		Reference Number			Notes	Rec Hours
			Load	Time	Pre BMS 92	BMS	Post-BMS 92		
W-2-Me-14	2 1/2"	Solid wall: steel channel per note 1, 2 1/2" thickness of 4.5:1:7, 4.5:1:7 portland cement, sawdust, and sand sprayed on wire mesh (see note 3 for wire mesh)	n/a	1 hr	-	1	-	-	1
W-2-Me-15	2 1/2"	Solid wall: steel channel per note 2, 2 1/2" thickness of 1:4, 1:4 portland cement spray on wire mesh (per note 3)	n/a	20 min	-	1	-	-	1/3
W-2-Me-16	2 1/2"	Solid wall: steel channel per note 2, 2 1/2" thickness of 1:2, 1:3 portland cement on metal lath	n/a	30 min	-	1	-	-	1/2
W-2-Me-17	2 1/2"	Solid wall: steel channel per note 2, 2 1/2" thickness of neat gypsum plaster on metal lath	n/a	2 hrs 30 min	-	1	-	-	2 1/2
W-2-Me-18	2 1/2"	Solid wall: steel channel per note 2, 2 1/2" thickness of 1: 1/2, 1: 1/2 gypsum plaster on metal lath	n/a	2 hrs	-	1	-	-	2
W-2-Me-19	2 1/2"	Solid wall: steel channel per note 2, 2 1/2" thickness of 1:1, 1:1 gypsum plaster on metal lath	n/a	1 hr 30 min	-	1	-	-	1 1/2
W-2-Me-20	2 1/2"	Solid wall: steel channel per note 2, 2 1/2" thickness of 1:2, 1:2 gypsum plaster on metal lath	n/a	1 hr	-	1	-	-	1
W-2-Me-21	2 1/2"	Solid wall: steel channel per note 2, 2 1/2" thickness of 1:2, 1:3 gypsum plaster on metal lath	n/a	1 hr	-	1	-	-	1
W-3-Me-22	3"	Core: steel channels per note 2, 1:2, 1:2 gypsum plaster on 3/4" soft asbestos lath, plaster thickness 2"	n/a	45 min	-	1	-	-	3/4
W-3-Me-23	3 1/2"	Solid wall: steel channel per note 2, 2 1/2" thickness of 1:2, 1:2 gypsum plaster on 3/4" asbestos lath	n/a	1 hr	-	1	-	-	1
W-3-Me-24	3 1/2"	Solid wall: steel channel per note 2, lath over and 1:2 1/2, 1:2 1/2 gypsum plaster on 1" magnesium oxy-sulfate wood fiberboard, plaster thickness 2 1/2"	n/a	1 hr	-	1	-	-	1
W-3-Me-25	3 1/2"	Core: steel studs per note 4; facings: 3/4" thickness of 1:1/30:2, 1:1/30:3 portland cement and asbestos fiber plaster	n/a	45 min	-	1	-	-	3/4
W-3-Me-26	3 1/2"	Core: steel studs per note 4; facings: both sides 3/4" thickness of 1:2, 1:3 portland cement	n/a	30 min	-	1	-	-	1/2
W-3-Me-27	3 1/2"	Core: steel studs per note 4; facings: both sides 3/4" thickness of neat gypsum plaster	n/a	1 hr 30 min	-	1	-	-	1 1/2

Table 1.2.1, continued (Metal Frame Walls, 0" to less than 4" thick)

Item Code	Thick-ness	Construction Details	Performance Load	Performance Time	Reference Number			Notes	Rec Hours
					Pre BMS 92	BMS	Post-BMS 92		
W-3-Me-28	3 1/2"	Core: steel studs per note 4; facings: both sides 3/4" thickness of 1:1/2, 1:1/2 gypsum plaster	n/a	1 hr 15 min	-	1	-	-	1 1/4
W-3-Me-29	3 1/2"	Core: steel studs per note 4; facings: both sides 3/4" thickness of 1:2, 1:2 gypsum plaster	n/a	1 hr	-	1	-	-	1
W-3-Me-30	3 1/2"	Core: steel studs per note 4; facings: both sides 3/4" thickness of 1:2, 1:3 gypsum plaster	n/a	45 min	-	1	-	-	3/4
W-3-Me-31	3 3/4"	Core: steel studs per note 4; facings: both sides 7/8" thickness of 1:1/30:2, 1:1/30:3 portland cement and asbestos fiber plaster	n/a	1 hr	-	1	-	-	1
W-3-Me-32	3 3/4"	Core: steel studs per note 4; facings: both sides 7/8" thickness of 1:2, 1:3 portland cement	n/a	45 min	-	1	-	-	3/4
W-3-Me-33	3 3/4"	Core: steel studs per note 4; facings: both sides 7/8" thickness of neat gypsum plaster	n/a	2 hrs	-	1	-	-	2
W-3-Me-34	3 3/4"	Core: steel studs per note 4; facings: both sides 7/8" thickness of 1:1/2, 1:1/2 gypsum plaster	n/a	1 hr 30 min	-	1	-	-	1 1/2
W-3-Me-35	3 3/4"	Core: steel studs per note 4; facings: both sides 7/8" thickness of 1:2, 1:2 gypsum plaster	n/a	1 hr 15 min	-	1	-	-	1 1/4
W-3-Me-36	3 3/4"	Core: steel per note 4; facings: 7/8" thickness of 1:2, 1:3 gypsum plaster on both sides	n/a	1 hr	-	1	-	-	1

Table 1.2.1—Notes**Metal Frame Walls, 0" to less than 4" thick**

1. Failure mode—local temperature rise—back face.
2. 3/4" or 1" channel framing—hot-rolled or strip-steel channels.
3. Reinforcement is 4" square mesh of No. 6 wire welded at intersections (no channels).
4. Ratings are for any usual type of non load-bearing metal framing providing 2" (or more) air space.

General Note

The construction details of the wall assemblies are as complete as the source documentation will permit. Data on the method of attachment of facings and the gauge of steel studs was provided when known. The cross-sectional area of the steel stud can be computed, thereby permitting a reasoned estimate of actual loading conditions. For load-bearing assemblies, the maximum allowable stress for the steel studs has been provided in the table "Notes." More often, it is the thermal properties of the facing materials, rather than the specific gauge of the steel, that will determine the degree of fire resistance. This is particularly true for non-bearing wall assemblies.

Figure 1.2.2
Metal Frame Walls, 4" (100 mm) to less than 6" (150 mm) thick

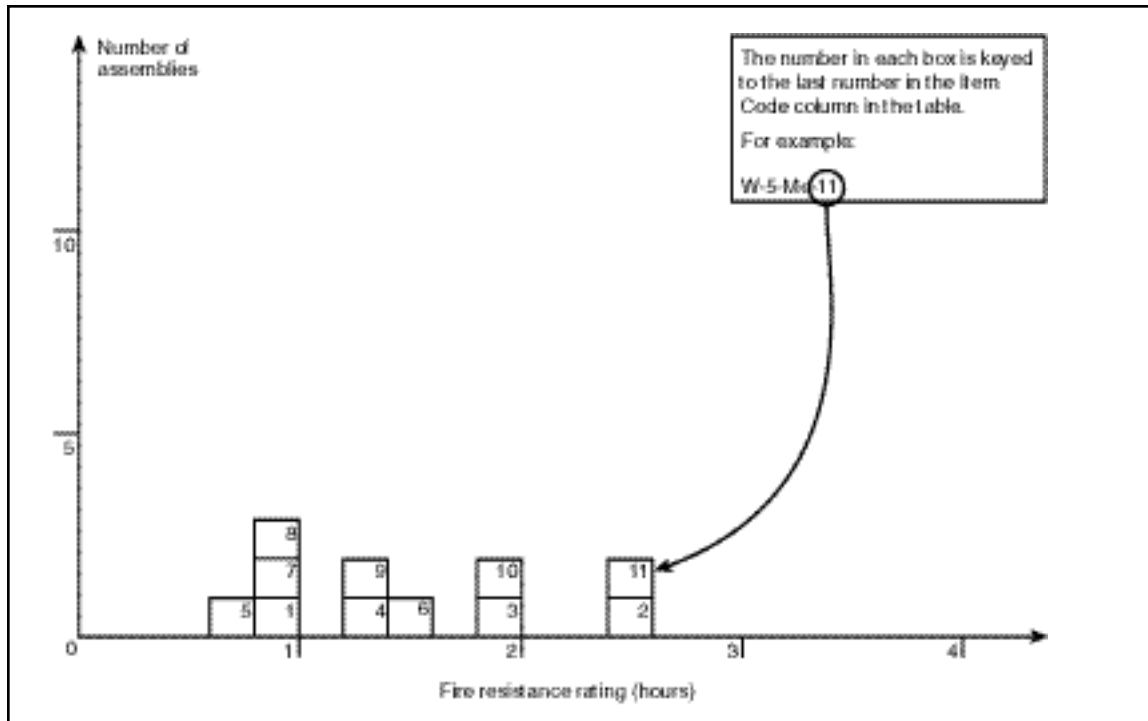

Table 1.2.2
Metal Frame Walls, 4" (100 mm) to less than 6" (150 mm) thick

Item Code	Thick-ness	Construction Details	Performance		Reference Number			Notes	Rec Hours
			Load	Time	Pre BMS 92	BMS	Post-BMS 92		
W-5-Me-1	5 1/2"	3" cavity with 16 ga. channel studs (3 1/2" O.C.) of 1/2" x 1/2" channel and 3" spacer; metal lath on ribs with plaster (3 coats) 3/4" over face of lath; plaster (each side); scratch coat—cement/lime/sand with hair; float coat—cement/lime/sand; finish coat—neat gypsum	n/a	1 hr 11 min	-	-	7	1	1
W-4-Me-2	4"	Core: steel studs per note 2; facings: both sides 1" thickness of neat gypsum plaster	n/a	2 hrs 30 min	-	1	-	-	2 1/2
W-4-Me-3	4"	Core: steel studs per note 2; facings: both sides 1" thickness of 1:1/2, 1:1/2 gypsum plaster	n/a	2 hrs	-	1	-	-	2
W-4-Me-4	4"	Core: steel per note 2; facings: both sides 1" thickness of 1:2, 1:3 gypsum plaster	n/a	1 hr 15 min	-	1	-	-	1 1/4

Table 1.2.2, continued (Metal Frame Walls, 4" to less than 6" thick)

Item Code	Thick-ness	Construction Details	Performance		Reference Number			Notes	Rec Hours
			Load	Time	Pre BMS 92	BMS	Post-BMS 92		
W-4-Me-5	4 1/2"	Core: lightweight steel stud 3" in depth; facings: both sides 3/4" thick sanded gypsum plaster, 1:2 scratch coat, 1:3 brown coat applied on metal lath	See note 4	45 min	-	1	-	5	3/4
W-4-Me-6	4 1/2"	Core: lightweight steel studs 3" in depth; facings: both sides 3/4" thick neat gypsum plaster on metal lath	See note 4	1 hr 30 min	-	1	-	5	1 1/2
W-4-Me-7	4 1/2"	Core: lightweight steel studs 3" in depth; facings: both sides 3/4" thick sanded gypsum plaster, 1:2 scratch and brown coats applied over metal lath	See note 4	1 hr	-	1	-	5	1
W-4-Me-8	4 3/4"	Core: lightweight steel studs 3" in depth; facings: both sides 7/8" thick sanded gypsum plaster, 1:2 scratch, 1:3 brown, applied over metal lath	See note 4	1 hr	-	1	-	5	1
W-4-Me-9	4 3/4"	Core: lightweight steel studs 3" in depth; facings: both sides 7/8" thick sanded gypsum plaster, 1:2 scratch and brown coats applied on metal lath	See note 4	1 hr 15 min	-	1	-	5	1 1/4
W-5-Me-10	5"	Core: lightweight steel studs 3" in depth; facings: both sides 1" thick neat gypsum plaster on metal lath	See note 4	2 hrs	-	1	-	5	2
W-5-Me-11	5"	Core: lightweight steel studs 3" in depth; facings: both sides 1" thick neat gypsum plaster on metal lath	See note 4	2 hrs 30 min	-	1	-	5,6	2 1/2

Table 1.2.2—Notes**Metal Frame Walls, 4" to less than 6" thick**

1. Failure mode—local back face temperature rise.
2. Ratings are for any usual type of non-bearing metal framing providing a minimum 2" air space.
3. Facing materials secured to lightweight steel studs not less than 3" deep.
4. Rating based on loading to develop a maximum stress of 7270 psi for net area of each stud.
5. Spacing of steel studs must be sufficient to develop adequate rigidity in the metal-lath or gypsum-plaster base.
6. As per note 4 but load/stud not to exceed 5120 psi.

General Note

The construction details of the wall assemblies are as complete as the source documentation will permit. Data on the method of attachment of facings and the gauge of steel studs was provided when known. The cross-sectional area of the steel stud can be computed, thereby permitting a reasoned estimate of actual loading conditions. For load-bearing assemblies, the maximum allowable stress for the steel studs has been provided in the table "Notes." More often, it is the thermal properties of the facing materials, rather than the specific gauge of the steel, that will determine the degree of fire resistance. This is particularly true for non-bearing wall assemblies.

Table 1.2.3
Metal Frame Walls, 6" (150 mm) to less than 8" (200 mm) thick

Item Code	Thick-ness	Construction Details	Performance		Reference Number			Notes	Rec Hours
			Load	Time	Pre BMS 92	BMS	Post-BMS 92		
W-6-Me-1	6 5/8"	On one side of 1" magnesium oxysulfate wood fiberboard sheathing attached to steel studs (see notes 1 and 2), 1" air space, and 3 3/4" brick secured with metal ties to steel frame every fifth course; inside facing of 7/8" 1:2 sanded gypsum plaster on metal lath secured directly to studs; plaster side exposed to fire	See note 2	1 hr 45 min	-	1	-	1	1 3/4
W-6-Me-2	6 5/8"	On one side of 1" magnesium oxysulfate wood fiberboard sheathing attached to steel studs (see notes 1 and 2), 1" air space, and 3 3/4" brick secured with metal ties to steel frame every fifth course; inside facing of 7/8" 1:2 sanded gypsum plaster on metal lath secured directly to studs; brick face exposed to fire	See note 2	4 hrs	-	1	-	1	4
W-6-Me-3	6 5/8"	On one side of 1" magnesium oxysulfate wood fiberboard sheathing attached to steel studs (see notes 1 and 2), 1" air space, and 3 3/4" brick secured with metal ties to steel frame every fifth course; inside facing of 7/8" vermiculite plaster on metal lath secured directly to studs; plaster side exposed to fire	See note 2	2 hrs	-	1	-	1	2

Table 1.2.3—Notes

Metal Frame Walls, 6" to less than 8" thick

1. Lightweight steel studs (minimum 3" deep) used. Stud spacing dependent on loading, but in each case, spacing is to be such that adequate rigidity is provided to the metal lath plaster base.
2. Load is such that stress developed in studs is not greater than 5120 psi calculated from net stud area.

General Note

The construction details of the wall assemblies are as complete as the source documentation will permit. Data on the method of attachment of facings and the gauge of steel studs was provided when known. The cross-sectional area of the steel stud can be computed, thereby permitting a reasoned estimate of actual loading conditions. For load-bearing assemblies, the maximum allowable stress for the steel studs has been provided in the table "Notes." More often, it is the thermal properties of the facing materials, rather than the specific gauge of the steel, that will determine the degree of fire resistance. This is particularly true for non-bearing wall assemblies.

TABLE 1.2.4
Metal Frame Walls, 8" (200 mm) to less than 10" (250 mm) thick

Item Code	Thick-ness	Construction Details	Performance		Reference Number			Notes	Rec Hours
			Load	Time	Pre BMS 92	BMS	Post-BMS 92		
W-9-Me-1	9 1/16"	On one side of 1/2" wood fiberboard sheathing next to studs, 3/4" air space formed with 3/4" x 1 5/8" wood strips placed over the fiberboard and secured to the studs; paper-backed wire lath nailed to strips 3 3/4" brick veneer held in place by filling a 3/4" space between the brick and paper-backed lath with mortar; inside facing of 3/4" neat gypsum plaster on metal lath attached to 5/16" plywood strips secured to edges of steel studs; rated as combustible because of the sheathing; see notes 1 and 2; plaster exposed	See note 2	1 hr 30 min	-	1	-	1	1 1/2
W-9-Me-2	9 1/16"	Same as above with brick exposed	See note 2	4 hrs	-	1	-	1	4
W-8-Me-3	8 1/2"	On one side of paper-backed wire lath attached to studs and 3 3/4" brick veneer held in place by filling a 1" space between the brick and lath with mortar; inside facing of 1" paper-enclosed mineral wool blanket weighing .6 lb/ft ² attached to studs, metal lath or paper-backed wire lath laid over the blanket and attached to the studs, and 3/4" sanded gypsum plaster 1:2 for the scratch and 1:3 for the brown coat (see notes 1 and 2); plaster face exposed	See note 2	4 hrs	-	1	-	1	4
W-8-Me-4	8 1/2"	Same as above with brick exposed	See note 2	5 hrs	-	1	-	1	5

Table 1.2.4—Notes

Metal Frame Walls, 8" to less than 10" thick

1. Lightweight steel studs 3" in depth. Stud spacing is dependent upon loading but in any case the spacing is to be such that adequate rigidity is provided to the metal-lath plaster base.
2. Load is such that stress developed in the steel studs is 5,120 psi calculated from net area of the stud.

General Note:

The construction details of the wall assemblies are as complete as the source documentation will permit. Data on the method of attachment of facings and the gauge of steel studs was provided when known. The cross-sectional area of the steel stud can be computed, thereby permitting a reasoned estimate of actual loading conditions. For load-bearing assemblies, the maximum allowable stress for the steel studs has been provided in the table "Notes." More often, it is the thermal properties of the facing materials, rather than the specific gauge of the steel, that will determine the degree of fire resistance. This is particularly true for non-bearing wall assemblies.

Table 1.3.1
Wood Frame Walls, 0" (0 mm) to less than 4" (100 mm) thick

Item Code	Thick-ness	Construction Details	Performance		Reference Number			Notes	Rec Hours
			Load	Time	Pre BMS 92	BMS	Post-BMS 92		
W-3-W-1	3 3/4"	Solid wall—2 1/4" wood-wool Slab core; 3/4" gypsum plaster each side	n/a	2 hrs	-	-	7	1,6	2
W-3-W-2	3 7/8"	2 x 4 stud wall, 3/16" thick cement asbestos board on both sides of wall	360 psi net area	10 min	-	1	-	2-5	1/6
W-3-W-3	3 7/8"	Same as W-3-W-2 but stud cavities filled with 1 lb/ft ² mineral wool batts	360 psi net area	40 min	-	1	-	2-5	2/3

Table 1.3.1—Notes

Wood Frame Walls, 0" to less than 4" thick

1. Achieved "Grade C" fire resistance (British).
2. Nominal 2 x 4 wood studs of No. 1 Common or better lumber set edgewise, 2 x 4 plates at top and bottom and blocking at mid-height of wall.
3. All horizontal joints in facing material backed by 2 x 4 blocking in wall.
4. Load = 360 psi of net stud cross-sectional area.
5. Facings secured with 6 d casing nails. Nail holes predrilled and 0.02"–0.03" smaller than nail diameter.
6. The wood-wool core is a pressed excelsior slab which possesses insulating properties similar to cellulosic insulation.

Figure 1.3.2
Wood Frame Walls, 4" (100 mm) to less than 6" (150 mm) thick

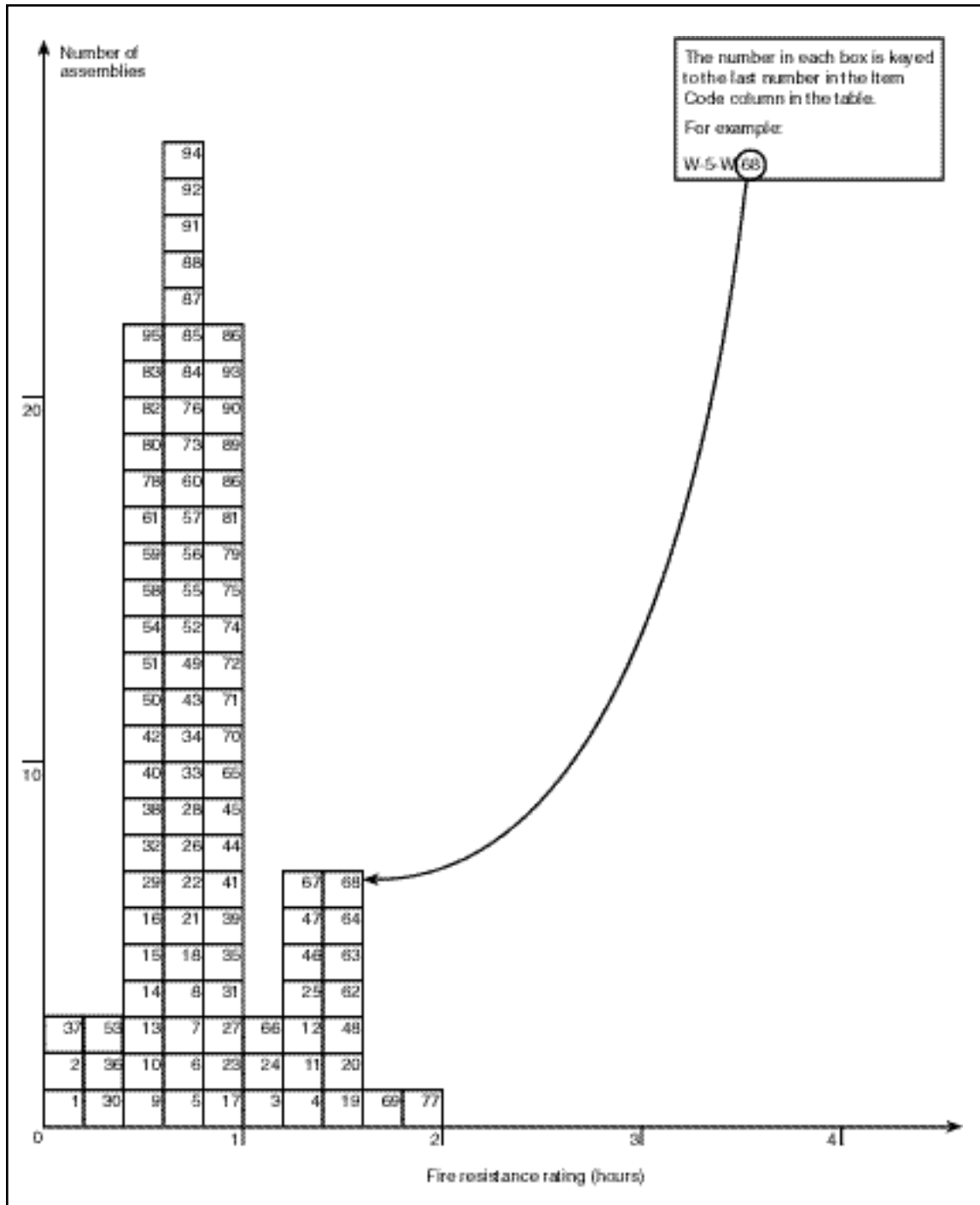

Table 1.3.2
Wood Frame Walls, 4" (100 mm) to less than 6" (150 mm) thick

Item Code	Thick-ness	Construction Details	Performance		Reference Number			Notes	Rec Hours
			Load	Time	Pre BMS 92	BMS	Post-BMS 92		
W-4-W-1	4"	2" x 4" stud wall; 3/16" CAB; no insulation; design A	35 min	10 min	-	-	4	1-10	1/6
W-4-W-2	4 1/8"	2" x 4" stud wall; 3/16" CAB; no insulation; design A	38 min	9 min	-	-	4	1-10	1/6
W-4-W-3	4 3/4"	2" x 4" stud wall; 3/16" CAB and 3/8" gypsum board face (both sides); design B	62 min	64 min	-	-	4	1-10	1
W-5-W-4	5"	2" x 4" stud wall; 3/16" CAB and 1/2" gypsum board face (both sides); design B	79 min	>90 min	-	-	4	1-10	1
W-4-W-5	4 3/4"	2" x 4" stud wall; 3/16" CAB and 3/8" gypsum board (both sides); design B	45 min	45 min	-	-	4	1-12	-
W-5-W-6	5"	2" x 4" stud wall; 3/16" CAB and 1/2" gypsum board face (both sides); design B	45 min	45 min	-	-	4	1-10,12-13	-
W-4-W-7	4"	2" x 4" stud wall; 3/16" CAB face; 3 1/2" mineral wool insulation; design C	40 min	42 min	-	-	4	1-10	2/3
W-4-W-8	4"	2" x 4" stud wall; 3/16" CAB face; 3 1/2" mineral wool insulation; design C	46 min	46 min	-	-	4	1-10,43	2/3
W-4-W-9	4"	2" x 4" stud wall; 3/16" CAB face; 3 1/2" mineral wool insulation; design C	30 min	30 min	-	-	4	1-10,12,14	-
W-4-W-10	4 1/8"	2" x 4" stud wall; 3/16" CAB face; 3 1/2" mineral wool insulation; design C	-	30 min	-	-	4	1-8,12,14	-
W-4-W-11	4 3/4"	2" x 4" stud wall; 3/16" CAB face; 3/8" gypsum strips over studs; 5 1/2" mineral wool insulation; design D	79 min	79 min	-	-	4	1-10	1
W-4-W-12	4 3/4"	2" x 4" stud wall; 3/16" CAB face; 3/8" gypsum strips @ stud edges; 7 1/2" mineral wool insulation; design D	82 min	82 min	-	-	4	1-10	1
W-4-W-13	4 3/4"	2" x 4" stud wall; 3/16" CAB face; 3/8" gypsum board strips over studs; 5 1/2" mineral wool insulation; design D	30 min	30 min	-	-	4	1-12	-
W-4-W-14	4 3/4"	2" x 4" stud wall; 3/16" CAB face; 3/8" gypsum board strips over studs; 7" mineral wool insulation; design D	30 min	30 min	-	-	4	1-12	-
W-5-W-15	5 1/2"	2" x 4" stud wall; exposed face—CAB shingles over 1" x 6"; unexposed face—1/8" CAB sheet; 7/16" fiberboard (wood); design E	34 min	-	-	-	4	1-10	1/2

Table 1.3.2, continued (Wood Frame Walls, 4" to less than 6" thick)

Item Code	Thick-ness	Construction Details	Performance		Reference Number			Notes	Rec Hours
			Load	Time	Pre BMS 92	BMS	Post-BMS 92		
W-5-W-16	5 1/2"	2" x 4" stud wall; exposed face—1/8" CAB sheet; 7/16" fiberboard; unexposed face—CAB shingles over 1" x 6"; design E	32 min	33 min	-	-	4	1-10	1/2
W-5-W-17	5 1/2"	2" x 4" stud wall; exposed face—CAB shingles over 1" x 6"; unexposed face—1/8" CAB sheet; gypsum board @ stud edges; 3 1/2" mineral wool insulation; design F	51 min	-	-	-	4	1-10	3/4
W-5-W-18	5 1/2"	2" x 4" stud wall; exposed face—1/8" CAB sheet; gypsum board @ stud edges; unexposed face—CAB shingles over 1" x 6"; 3 1/2" mineral wool insulation; design F	42 min	-	-	-	4	1-10	2/3
W-5-W-19	5 5/8"	2" x 4" stud wall; exposed face—CAB shingles over 1" x 6"; unexposed face—1/8" CAB sheet, gypsum board @ stud edges; 5 1/2" mineral wool insulation; design G	74 min	85 min	-	-	4	1-10	1
W-5-W-20	5 5/8"	2" x 4" stud wall; unexposed face—CAB shingles over 1" x 6"; exposed face—1/8" CAB sheet, gypsum board @ 3/16" stud edges; 7/16" fiberboard; 5 1/2" mineral wool insulation; design G	79 min	85 min	-	-	4	1-10	1 1/4
W-5-W-21	5 5/8"	2" x 4" stud wall; exposed face—CAB shingles 1"x 6" sheathing; unexposed face—CAB sheet, gypsum board @ stud edges; 5 1/2" mineral wool insulation; design G	38 min	38 min	-	-	4	1-10,12,14	-
W-5-W-22	5 5/8"	2" x 4" stud wall; exposed face—CAB sheet, gypsum board @ stud edges; unexposed face—CAB shingles 1" x 6" sheathing; 5 1/2" mineral wool insulation; design G	38 min	38 min	-	-	4	1-12	-
W-6-W-23	6"	2" x 4" stud wall; 16" O.C.; 1/2" gypsum board each side; 1/2" gypsum plaster each side	n/a	60 min	-	-	7	15	1
W-6-W-24	6"	2" x 4" stud wall; 16" O.C.; 1/2" gypsum board each side; 1/2" gypsum plaster each side	n/a	68 min	-	-	7	16	1
W-6-W-25	6 7/8"	2" x 4" stud wall; 18" O.C.; 3/4" gypsum plank each side; 3/16" gypsum plaster each side	n/a	80 min	-	-	7	15	1 1/3
W-5-W-26	5 1/8"	2" x 4" stud wall; 16" O.C.; 3/8" gypsum board each side; 3/16" gypsum plaster each side	n/a	37 min	-	-	7	15	1/2
W-5-W-27	5 3/4"	2" x 4" stud wall; 16" O.C.; 3/8" gypsum lath each side; 1/2" gypsum plaster each side	n/a	52 min	-	-	7	15	3/4

Table 1.3.2, continued (Wood Frame Walls, 4" to less than 6" thick)

Item Code	Thick-ness	Construction Details	Performance		Reference Number			Notes	Rec Hours
			Load	Time	Pre BMS 92	BMS	Post-BMS 92		
W-5-W-28	5"	2" x 4" stud wall; 16" O.C.; 1/2" gypsum board each side	n/a	37 min	-	-	7	16	1/2
W-5-W-29	5"	2" x 4" stud wall; 1/2" fiberboard both sides 14% M.C. with F.R. paint @ 35 gm/ft ²	n/a	28 min	-	-	7	15	1/3
W-4-W-30	4 3/4"	2" x 4" stud wall; fire side—1/2" (wood) fiberboard; back face—1/4" CAB; 16" O.C.	n/a	17 min	-	-	7	15,16	1/4
W-5-W-31	5 1/8"	2" x 4" stud wall; 16" O.C.; 1/2" fiberboard insulation with 1/32" asbestos (both sides of each board)	n/a	50 min	-	-	7	16	3/4
W-4-W-32	4 1/4"	2" x 4" stud wall; 3/8" thick gypsum wallboard on both faces; insulated cavities	note 23	25 min	-	1	-	17,18,23	1/3
W-4-W-33	4 1/2"	2" x 4" stud wall; 1/2" thick gypsum wallboard on both faces	note 17	40 min	-	1	-	17,23	2/3
W-4-W-34	4 1/2"	2" x 4" stud wall; 1/2" thick gypsum wallboard on both faces; insulated cavities	note 17	45 min	-	1	-	17,18,23	3/4
W-4-W-35	4 1/2"	2" x 4" stud wall; 1/2" thick gypsum wallboard on both faces; insulated cavities	n/a	1 hr	-	1	-	17,18,24	1
W-4-W-36	4 1/2"	2" x 4" stud wall; 1/2" thick, 1.1 lb/ft ² wood fiberboard sheathing on both faces	note 23	15 min	-	1	-	17,23	1/4
W-4-W-37	4 1/2"	2" x 4" stud wall; 1/2" thick, 0.7 lb/ft ² wood fiberboard sheathing on both faces	note 23	10 min	-	1	-	17,23	1/6
W-4-W-38	4 1/2"	2" x 4" stud wall; 1/2" thick, "flameproofed," 1.6 lb/ft ² wood fiberboard sheathing on both faces	note 23	30 min	-	1	-	17,23	1/2
W-4-W-39	4 1/2"	2" x 4" stud wall; 1/2" thick gypsum wallboard on both faces; insulated cavities	note 23	1 hr	-	1	-	17,18,23	1
W-4-W-40	4 1/2"	2" x 4" stud wall; 1/2" thick, 1:2, 1:3 gypsum plaster on wood lath on both faces	note 23	30 min	-	1	-	17,21,23	1/2
W-4-W-41	4 1/2"	2" x 4" stud wall; 1/2" thick, 1:2, 1:3 gypsum plaster on wood lath on both faces; insulated cavities	note 23	1 hr	-	1	-	17,18,21,23	1
W-4-W-42	4 1/2"	2" x 4" stud wall; 1/2" thick, 1:5, 1:7.5 lime plaster on wood lath on both wall faces	note 23	30 min	-	1	-	17,21,23	1/2
W-4-W-43	4 1/2"	2" x 4" stud wall; 1/2" thick, 1:5, 1:7.5 lime plaster on wood lath on both faces, insulated cavities	note 23	45 min	-	1	-	17,18,21,23	3/4

Table 1.3.2, continued (Wood Frame Walls, 4" to less than 6" thick)

Item Code	Thick-ness	Construction Details	Performance		Reference Number			Notes	Rec Hours
			Load	Time	Pre BMS 92	BMS	Post-BMS 92		
W-4-W-44	4 5/8"	2" x 4" stud wall; 3/16" thick cement-asbestos over 3/8" thick gypsum board on both faces	note 23	1 hr	-	1	-	23,25,26,27	1
W-4-W-45	4 5/8"	2" x 4" stud wall; studs faced with 4" wide strips of 3/8" thick gypsum board; 3/16" thick cement-asbestos board on both faces; insulated cavities	note 23	1 hr	-	1	-	23,25,27,28	1
W-4-W-46	4 5/8"	Same as W-4-W-45 but non-load bearing	n/a	1 hr 15 min	-	1	-	24,28	1 1/4
W-4-W-47	4 7/8"	2" x 4" stud wall; 3/16" thick cement-asbestos board over 1/2" thick gypsum sheathing on both faces	note 23	1 hr 15 min	-	1	-	23,25,26,27	1 1/4
W-4-W-48	4 7/8"	Same as W-4-W-47 but non-load bearing	n/a	1 hr 30 min	-	1	-	24,27	1 1/2
W-5-W-49	5"	2" x 4" stud wall; exterior face: 3/4" wood sheathing, asbestos felt 14 lb/100 ft ² and 5/32" cement-asbestos shingles; interior face 4" wide strips of 3/8" gypsum board over studs; wall faced with 3/16" thick cement-asbestos board	note 23	40 min	-	1	-	18,23,25,26,29	2/3
W-5-W-50	5"	2" x 4" stud wall; exterior face as per W-5-W-49; interior face: 9/16" composite board consisting of 7/16" thick wood fiberboard faced with 1/8" thick cement-asbestos board; exterior side exposed to fire	note 23	30 min	-	1	-	23,25,26,30	1/2
W-5-W-51	5"	Same as W-5-W-50 but interior side exposed to fire	note 23	30 min	-	1	-	23,25,26	1/2
W-5-W-52	5"	Same as W-5-W-49 but exterior side exposed to fire	note 23	45 min	-	1	-	18,23,25,26	3/4
W-5-W-53	5"	2" x 4" stud wall; 3/4" thick T&G wood boards on both sides.	note 23	20 min	-	1	-	17,23	1/3
W-5-W-54	5"	Same as W-5-W-53 but with insulated cavities	note 23	35 min	-	1	-	17,18,23	1/2
W-5-W-55	5"	2" x 4" stud wall; 3/4" thick T&G wood boards on both sides with 30 lb/100 ft ² asbestos, paper between studs and boards	note 23	45 min	-	1	-	17,23	3/4
W-5-W-56	5"	2" x 4" stud wall; 1/2" thick, 1:2, 1:3 gypsum plaster on metal lath on both sides of wall	note 23	45 min	-	1	-	17,21,23	3/4
W-5-W-57	5"	2" x 4" stud wall; 3/4" thick 2:1:8, 2:1:12 lime and Keene's cement plaster on metal lath, both sides of wall	note 23	45 min	-	1	-	17,21,23	3/4
W-5-W-58	5"	2" x 4" stud wall; 3/4" thick 2:1:8, 2:1:10 lime portland cement plaster over metal lath on both sides of wall	note 23	30 min	-	1	-	17,21,23	1/2
W-5-W-59	5"	2" x 4" stud wall; 3/4" thick 1:5, 1:7.5 lime plaster on metal lath on both sides of wall	note 23	30 min	-	1	-	17,21,23	1/2

Table 1.3.2, continued (Wood Frame Walls, 4" to less than 6" thick)

Item Code	Thick-ness	Construction Details	Performance		Reference Number			Notes	Rec Hours
			Load	Time	Pre BMS 92	BMS	Post-BMS 92		
W-5-W-60	5"	2" x 4" stud wall; 3/4" thick, 1:1/30:2, 1:1/30:3 portland cement, asbestos fiber plaster on metal lath on both sides of wall	note 23	45 min	-	1	-	17,21,23	3/4
W-5-W-61	5"	2" x 4" stud wall; 3/4" thick 1:2, 1:3 portland cement plaster on metal lath on both sides of wall	note 23	30 min	-	1	-	17,21,23	1/2
W-5-W-62	5"	2" x 4" stud wall; 3/4" thick neat plaster on metal lath on both sides of wall	n/a	1 hr 30 min	-	1	-	17,22,24	1 1/2
W-5-W-63	5"	2" x 4" stud wall; 3/4" thick neat gypsum plaster on metal lath on both sides of wall	note 23	1 hr 30 min	-	1	-	17,21,23	1 1/2
W-5-W-64	5"	2" x 4" stud wall; 3/4" thick 1:2, 1:2 gypsum plaster on metal lath on both sides of wall, insulated cavities	note 23	1 hr 30 min	-	1	-	17,18,21,23	1 1/2
W-5-W-65	5"	2" x 4" stud wall, same as W-5-W-64 but wall cavities not insulated	note 23	1 hr	-	1	-	17,21,23	1
W-5-W-66	5"	2" x 4" stud wall; 3/4" thick 1:2, 1:3 gypsum plaster on metal lath on both sides of wall, insulated cavities	note 23	1 hr 15 min	-	1	-	17,18,21,23	1 1/4
W-5-W-67	5 1/16"	Same as W-5-W-49 except cavity insulation of 1 3/4 lb/ft ² mineral wool bats; rating applies when either wall side exposed to fire	note 23	1 hr 15 min	-	1	-	23,25,26	1 1/4
W-5-W-68	5 1/4"	2" x 4" stud wall; 7/8" thick 1:2, 1:3 gypsum plaster on metal lath on both sides of wall, insulated cavities	note 23	1 hr 30 min	-	1	-	17,18,21,23	1 1/2
W-5-W-69	5 1/4"	2" x 4" stud wall; 7/8" thick neat gypsum plaster applied on metal lath, on both sides of wall	n/a	1 hr 45 min	-	1	-	17,22,24	1 3/4
W-5-W-70	5 1/4"	2" x 4" stud wall; 1/2" thick neat gypsum plaster on 3/8" plain gypsum lath, both sides of wall	note 23	1 hr	-	1	-	17,22,23	1
W-5-W-71	5 1/4"	2" x 4" stud wall; 1/2" thick, 1:2, 1:2 gypsum plaster on 3/8" thick plain gypsum lath with 1 3/4" x 1 3/4" metal lath pads nailed 8" O.C. vertically, 16" O.C. horizontally, both sides of wall	note 23	1 hr	-	1	-	17,21,23	1
W-5-W-72	5 1/4"	2" x 4" stud wall; 1/2" thick 1:2, 1:2 gypsum plaster on 3/8" perforated gypsum lath, one 3/4" diameter hole or larger per 16" sq. in. of lath surface, both sides of wall	note 23	1 hr	-	1	-	17,21,23	1
W-5-W-73	5 1/4"	2" x 4" stud wall; 1/2" thick 1:2, 1:2 gypsum plaster on 3/8" gypsum lath (plain, indented or perforated) both sides of wall	note 23	45 min	-	1	-	17,21,23	3/4

Table 1.3.2, continued (Wood Frame Walls, 4" to less than 6" thick)

Item Code	Thick-ness	Construction Details	Performance		Reference Number			Notes	Rec Hours
			Load	Time	Pre BMS 92	BMS	Post-BMS 92		
W-5-W-74	5 1/4"	2" x 4" stud wall; 7/8" thick 1:2, 1:3 gypsum plaster over metal lath on both sides of wall	note 23	1 hr	-	1	-	17,21,23	1
W-5-W-75	5 1/4"	2" x 4" stud wall; 7/8" thick 1:1/30:2, 1:1/30:3 portland cement, asbestos plaster applied over metal lath on both sides of wall	note 23	1 hr	-	1	-	17,21,23	1
W-5-W-76	5 1/4"	2" x 4" stud wall; 7/8" thick 1:2, 1:3 portland cement plaster over metal lath on both sides of wall	note 23	45 min	-	1	-	17,21,23	3/4
W-5-W-77	5 1/2"	2" x 4" stud wall; 1" thick neat gypsum plaster over metal lath on both sides of wall, non-load bearing	n/a	2 hrs	-	1	-	17,22,24	2
W-5-W-78	5 1/2"	2" x 4" stud wall; 1/2" thick 1:2, 1:2 gypsum plaster on 1/2" thick, 0.7 lb/ft ² wood fiberboard both sides of wall	note 23	35 min	-	1	-	17,21,23	1/2
W-4-W-79	4 3/4"	2" x 4" wood stud wall; 1/2" thick 1:2, 1:2 gypsum plaster over wood lath on both sides of wall; mineral wool insulation	n/a	1 hr	-	-	43	21,31,35,38	1
W-4-W-80	4 3/4"	Same as W-4-W-79 but uninsulated	n/a	35 min	-	-	43	21,31,35	1/2
W-4-W-81	4 3/4"	2" x 4" wood stud wall; 1/2" thick 3:1:8, 3:1:12 lime, Keene's cement, sand plaster over wood lath both sides of wall; mineral wool insulation	n/a	1 hr	-	-	43	21,31,35,40	1
W-4-W-82	4 3/4"	2" x 4" wood stud wall; 1/2" thick 1:6 1/4, 1:6 1/4 lime Keene's cement plaster over wood lath both sides of wall; mineral wool insulation	n/a	30 min	-	-	43	21,31,35,40	1/2
W-4-W-83	4 3/4"	2" x 4" wood stud wall; 1/2" thick 1:5, 1:7.5 lime plaster over wood lath on both sides of wall	n/a	30 min	-	-	43	21,31,35	1/2
W-5-W-84	5 1/8"	2" x 4" wood stud wall; 11/16" thick 1:5, 1:7.5 lime plaster over wood lath on both sides of wall; mineral wool insulation	n/a	45 min	-	-	43	21,31,35,39	1/2
W-5-W-85	5 1/4"	2" x 4" wood stud wall; 3/4" thick 1:5, 1:7 lime plaster over wood lath on both sides of wall; mineral wool insulation	n/a	40 min	-	-	43	21,31,35,40	2/3
W-5-W-86	5 1/4"	2" x 4" wood stud wall; 1/2" thick 2:1:12 lime, Keene's cement and sand scratch coat, 1/2" thick 2:1:18 lime, Keene's cement, and sand brown coat over wood lath on both sides of wall; mineral wool insula-tion	n/a	1 hr	-	-	43	21,31,35,40	1

Table 1.3.2, continued (Wood Frame Walls, 4" to less than 6" thick)

Item Code	Thick-ness	Construction Details	Performance Load	Performance Time	Reference Number			Notes	Rec Hours
					Pre BMS 92	BMS	Post-BMS 92		
W-5-W-87	5 1/4"	2" x 4" wood stud wall; 1/2" thick 1:2, 1:2 gypsum plaster over 3/8" thick plaster board on both sides of wall	n/a	45 min	-	-	43	21,31	3/4
W-5-W-88	5 1/4"	2" x 4" wood stud wall; 1/2" thick 1:2, 1:2 gypsum plaster over 3/8" thick gypsum lath on both sides of wall	n/a	45 min	-	-	43	21,31	3/4
W-5-W-89	5 1/4"	2" x 4" wood stud wall; 1/2" thick 1:2, 1:2 gypsum plaster over 3/8" gypsum lath, on both sides of wall	n/a	1 hr	-	-	43	21,31,33	1
W-5-W-90	5 1/4"	2" x 4" wood stud wall; 1/2" thick neat plaster over 3/8" thick gypsum lath, on both sides of wall	n/a	1 hr	-	-	43	21,22,31	1
W-5-W-91	5 1/4"	2" x 4" wood stud wall; 1/2" thick 1:2, 1:2 gypsum plaster over 3/8" thick indented gypsum lath, on both sides of wall	n/a	45 min	-	-	43	21,31	3/4
W-5-W-92	5 1/4"	2" x 4" wood stud wall; 1/2" thick 1:2, 1:2 gypsum plaster over perforated gypsum lath, 3/8" thick on both wall faces	n/a	45 min	-	-	43	21,31,34	3/4
W-5-W-93	5 1/4"	2" x 4" wood stud wall; 1/2" thick 1:2, 1:2 gypsum plaster over 3/8" thick perforated gypsum lath on both sides of wall	n/a	1 hr	-	-	43	21,31	1
W-5-W-94	5 1/4"	2" x 4" wood stud wall; 1/2" thick 1:2, 1:2 gypsum plaster over perforated gypsum lath 3/8" thick over both sides of wall	n/a	45 min	-	-	43	21,31,34	3/4
W-5-W-95	5 1/4"	2" x 4" wood stud wall; 1/2" thick 1:2, 1:2 gypsum plaster over 1/2" thick wood fiberboard plaster base on both sides of wall	n/a	35 min	-	-	43	21,31,36	1/2
W-5-W-96	5 3/4"	2" x 4" wood stud wall; 1/2" thick 1:2, 1:2 gypsum plaster over 7/8" thick flameproofed wood fiberboard, on both sides of wall	n/a	1 hr	-	-	43	21,31,37	1

Table 1.3.2—Notes**Wood Frame Walls, 4" (100 mm) to less than 6" (150 mm) thick**

1. All specimens 8' or 8'8" x 10'4"—i.e., 1/2 of furnace size. See note 42 for design cross section.
2. Specimens tested in tandem (two per exposure).
3. Test per ASANo. A-2-1934 except where unloaded. Also, panels were of "half" size of furnace opening. Time value signifies a thermal failure time.
4. 2" x 4" studs, 16" O.C.; where 10'4", blocking @ 2'4" height.
5. Facing 4' x 8', cement-asbestos board sheets 3/16" thick.
6. Sheathing (diagonal) 25/32" x 5 1/2" on 1" x 6" pine.
7. Facing shingles—24" x 12" x 5/32" where used.
8. Asbestos felt—asphalt set between sheathing and shingles.
9. Load—30,500 lbs or 360 psi/stud where load was tested.
10. Walls were tested beyond achievement of first test end point. A load bearing time in excess of performance time indicates that although thermal criteria were exceeded load bearing ability continued.
11. Wall was rated for 1 hr combustible use in original source.
12. Hose stream test specimen. See table entry of similar design for recommended rating.
13. Rated 1 1/4 hr load bearing. Rated 1 1/2 hr non-load bearing.
14. Failed hose stream.
15. Test terminated due to flame penetration.
16. Test terminated—local back face temperature rise.
17. Nominal 2" x 4" wood studs of No. 1 common or better lumber set edge-wise. 2" x 4" plates at top and bottom and blocking at mid-height of wall.
18. Cavity insulation consists of rock wool bats 1.0 lb/ft² of filled cavity area.
19. Cavity insulation consists of glass-wool bats 0.6 lb/ft² of filled cavity area.
20. Cavity insulation consists of blown-in forck wool 2.0 lb/ft² of filled cavity area.
21. Mix proportions for plastered walls as follows: first ratio indicates scratch coat mix, weight of dry plaster to dry sand; second ratio indicates brown coat mix.
22. "Neat" plaster is taken to mean unsanded wood-fiber gypsum plaster.
23. Load = 360 psi of net stud cross-sectional area.
24. Rated as non-load bearing.
25. Nominal 2" x 4" studs per note 17, spaced at 16" on center.
26. Horizontal joints in facing material supported by 2" x 4" blocking within wall.
27. Facings secured with 6 d casing nails. Nail holes predrilled and were 0.02"—0.03" smaller than nail diameter.
28. Cavity insulation consists of mineral wool bats weighing 2 lb/ft² of filled cavity area.
29. Interior wall face exposed to fire.
30. Exterior wall face exposed to fire.
31. Nominal 2" x 4" studs of yellow pine or Douglas fir spaced 16" on center in a single row.
32. Studs as in note 31 except double row, with studs in rows staggered.
33. Six roofing nails with metal-lath pads around heads to each 16" x 48" lath.
34. Areas of holes less than 2 3/4% of area of lath.
35. Wood laths were nailed with either 3 d or 4 d nails, one nail to each bearing, and the end joining broken every 7th course.
36. 1/2" thick fiberboard plaster base nailed with 3 d or 4 d common wire nails spaced 4" x 6" on center.
37. 7/8" thick fiberboard plaster base nailed with 5 d common wire nails spaced 4" x 6" on center.
38. Mineral wool bats 1.05–1.25 lb/ft² with waterproofed-paper backing.
39. Blown-in mineral wool insulation, 2.2 lb/ft².
40. Mineral wool bats, 1.4 lb/ft² with waterproofed-paper backing.
41. Mineral wool bats, 0.9 lb/ft².
42. See wall design diagram, below.
43. Duplicate specimen of W-4-W-7, tested simultaneously with W-4-W-7 in 18 ft. test furnace

**Note 42, Table 1.3.2**

Table 1.3.3
Wood Frame Walls, 6"(150 mm) to less than 8" (200 mm) thick

Item Code	Thick-ness	Construction Details	Performance		Reference Number			Notes	Rec Hours
			Load	Time	Pre BMS 92	BMS	Post-BMS 92		
W-6-W-1	6 1/4"	2" x 4" stud wall, 1/2" thick, 1:2, 1:2 gypsum plaster on 7/8" "flame-proofed" wood fiberboard weighing 2.8 lb/ft ² —both sides of wall	note 3	1 hr	-	1	-	1-3	1
W-6-W-2	6 1/2"	2" x 4" stud wall, 1/2" thick, 1:3, 1:3 gypsum plaster on 1" thick magnesium oxysulfate wood fiberboard—both sides of wall	note 3	45 min	-	1	-	1-3	3/4
W-7-W-3	7 1/4"	Double row of 2" x 4" studs, 1/2" thick 1:2, 1:2 gypsum plaster applied over 3/8" thick perforated gypsum lath on both sides of wall; mineral wool insulation	n/a	1 hr	-	-	43	2,4,5	1
W-7-W-4	7 1/2"	Double row of 2" x 4" studs, 5/8" thick 1:2, 1:2 gypsum plaster applied over 3/8" thick perforated gypsum lath overlaid with 2" x 2", 16 gauge wire fabric, on both sides of wall.	n/a	1 hr 15 min	-	-	43	2,4	1 1/4

Table 1.3.3—Notes

Wood Frame Walls, 6"(150 mm) to less than 8" (200 mm) thick

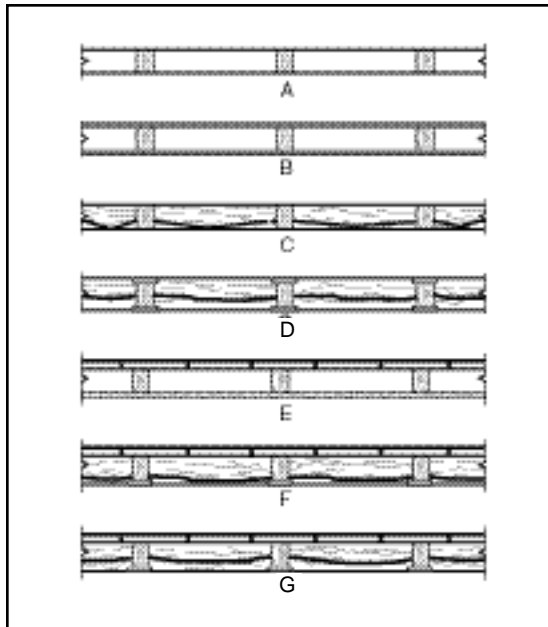
- Nominal 2 x 4 wood studs of No. 1 common or better lumber set edgewise. 2 x 4 plates at top and bottom and blocking at mid-height of wall.
- Mix proportions for plastered walls as follows: first ratio indicates scratch coat mix, weight of dry plaster to dry sand; second ratio indicates brown coat mix.
- Load = 360 psi of net stud cross-sectional area.
- Nominal 2 x 4 studs of yellow pine or Douglas fir spaced 16" in a double row, with studs in rows staggered.
- Mineral wool bats, 0.19 lb/ft².

Table 1.4.1
Walls—Miscellaneous Materials, 0" (0 mm) to less than 4" (100 mm) thick

Item Code	Thick-ness	Construction Details	Performance		Reference Number			Notes	Rec Hours
			Load	Time	Pre BMS 92	BMS	Post-BMS 92		
W-3-Mi-1	3 7/8"	Glass brick wall (bricks 5 3/4" x 5 3/4" x 3 7/8"), 1/4" mortar bed of cement/lime/sand; mounted in brick (9") wall with mastic and 1/2" asbestos rope	n/a	1 hr	-	-	7	1,2	1
W-3-Mi-2	3"	Core: 2" magnesium oxysulfate wood-fiber blocks laid in portland cement-lime mortar; facings on both sides; see note 3	n/a	1 hr	-	1	-	3	1
W-3-Mi-3	3 7/8"	Core: 8" X 4 7/8" glass blocks 3 7/8" thick weighing 4 lbs. each; laid in portland cement-lime mortar, horizontal mortar joints reinforced with metal lath.	n/a	1/4 hr	-	1	-	-	1/4

Table 1.4.1—Notes

Walls—Miscellaneous Materials, 0" to less than 4" thick

1. No failure reached at 1 hour.
2. These glass blocks are assumed to be solid based on other test data available for similar but hollow units that show significantly reduced fire endurance.
3. Minimum of 1/2" of 1:3 sanded gypsum plaster required to develop this rating.

Table 1.4.2
Walls—Miscellaneous Materials, 4" (100 mm) to less than 6" (150 mm) thick

Item Code	Thick-ness	Construction Details	Performance		Reference Number			Notes	Rec Hours
			Load	Time	Pre BMS 92	BMS	Post-BMS 92		
W-4-Mi-1	4"	Core: 3" magnesium oxysulfate wood-fiber blocks laid in portland cement mortar; facings: both sides per note 1	n/a	2 hrs	-	1	-	-	2

Table 1.4.2—Notes

Miscellaneous Materials, 4" to less than 6" thick

1. 1/2" sanded gypsum plaster. Voids in hollow blocks to be not more than 30%.

Figure 1.5.1
Finish Ratings—Inorganic Materials

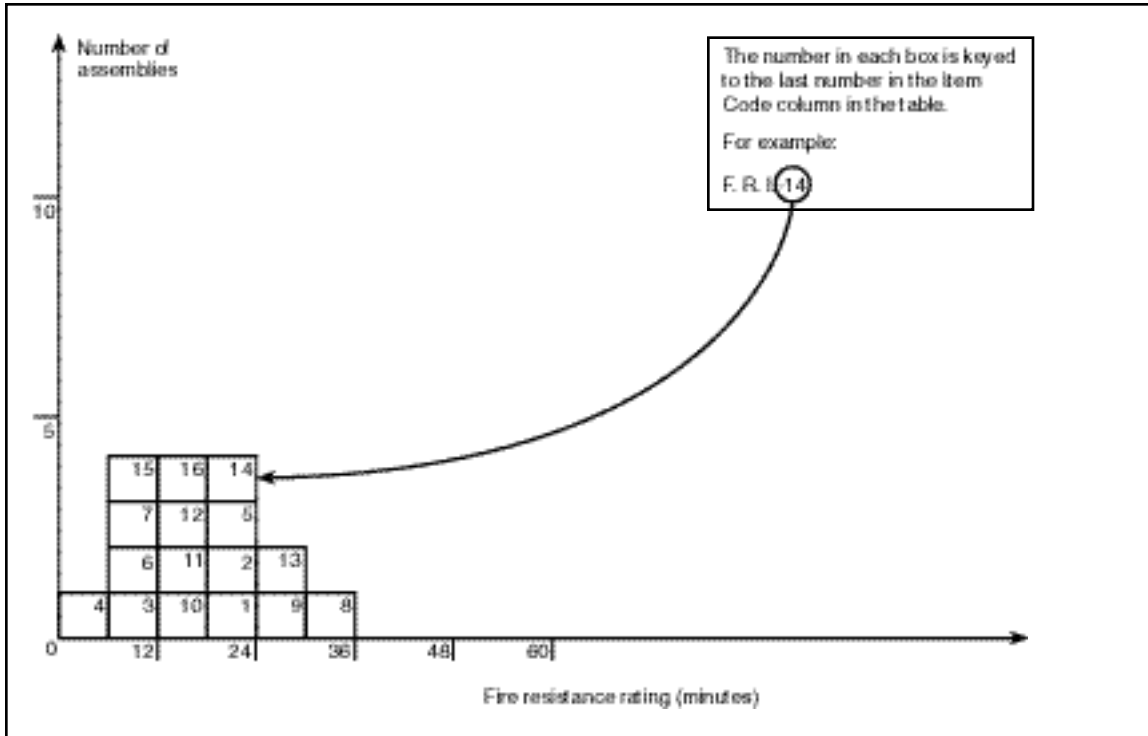

Table 1.5.1
Finish Ratings—Inorganic Materials

Item Code	Thick-ness	Construction Details	Performance Finish Rating	Reference Number			Notes	Rec F.R. Min.
				Pre BMS 92	BMS	Post-BMS 92		
FR-I-1	9/16"	3/8" gypsum wallboard faced with 3/16" cement asbestos board	20 min	-	1	-	1,2	15
FR-I-2	11/16"	1/2" gypsum sheathing faced with 3/16" cement asbestos board	20 min	-	1	-	1,2	20
FR-I-3	3/16"	3/16" cement asbestos board over uninsulated cavity	10 min	-	1	-	1,2	5
FR-I-4	3/16"	3/16" cement asbestos board over insulated cavities	5 min	-	1	-	1,2	5
FR-I-5	3/4"	3/4" thick 1:2, 1:3 gypsum plaster over paper-backed metal lath	20 min	-	1	-	1-3	20
FR-I-6	3/4"	3/4" thick portland cement plaster on metal lath	10 min	-	1	-	1,2	10
FR-I-7	3/4"	3/4" thick, 1:5, 1:7.5 lime plaster on metal lath	10 min	-	1	-	1,2	10

Table 1.5.1, continued (Finish Ratings—Inorganic Materials)

Item Code	Thick-ness	Construction Details	Performance Finish Rating	Reference Number			Notes	Rec F.R. Min.
				Pre BMS 92	BMS	Post-BMS 92		
FR-I-8	1"	1" thick neat gypsum plaster on metal lath	35 min	-	1	-	1,2,4	35
FR-I-9	3/4"	3/4" thick neat gypsum plaster on metal lath	30 min	-	1	-	1,2,4	30
FR-I-10	3/4"	3/4" thick 1:2, 1:2 gypsum plaster on metal lath	15 min	-	1	-	1-3	15
FR-I-11	1/2"	Same as FR.-I-7, except 1/2" thick on wood lath	15 min	-	1	-	1-3	15
FR-I-12	1/2"	1/2" thick, 1:2, 1:3 gypsum plaster on wood lath	15 min	-	1	-	1-3	15
FR-I-13	7/8"	1/2" thick, 1:2, 1:2 gypsum plaster on 3/8" perforated gypsum lath	30 min	-	1	-	1-3	30
FR-I-14	7/8"	1/2" thick, 1:2, 1:2 gypsum plaster on 3/8" thick plain or indented gypsum plaster	20 min	-	1	-	1-3	20
FR-I-15	3/8"	3/8" gypsum wallboard	10 min	-	1	-	1,2	10
FR-I-16	1/2"	1/2" gypsum wallboard	15 min	-	1	-	1,2	15

Table 1.5.1—Notes
Finish Ratings—Inorganic Materials

1. The finish rating is the time required to obtain an average temperature rise of 250°F, or a single point rise of 325°F, at the interface between the material being rated and the substrate being protected.
2. Tested in accordance with the Standard Specifications for Fire Tests of Building Construction and Materials, ASANo. A2-1932.
3. Mix proportions for plaster as follows: first ratio, dry weight of plaster to dry weight of sand for scratch coat; second ratio, plaster to sand for brown coat.
4. Neat plaster means unsanded wood-fiber gypsum plaster.

Table 1.5.2
Finish Ratings—Organic Materials

Item Code	Thick-ness	Construction Details	Performance Finish Rating	Reference Number			Notes	Rec F.R. Min.
				Pre BMS 92	BMS	Post-BMS 92		
FR-0-1	9/16"	7/16" wood fiberboard faced with 1/8" cement asbestos board	15 min	-	1	-	1,2	15
FR-0-2	2 9/32"	3/4" wood sheathing, asbestos felt weighing 14 lb/100 ft ² and 5/32" cement asbestos shingles	20 min	-	1	-	1,2	20
FR-0-3	1 1/2"	1" thick magnesium oxysulfate wood fiberboard faced with 1:3, 1:3 gypsum plaster, 1/2" thick	20 min	-	1	-	1-3	20
FR-0-4	1/2"	1/2" thick wood fiberboard	5 min	-	1	-	1,2	5
FR-0-5	1/2"	1/2" thick flameproofed wood fiberboard	10 min	-	1	-	1,2	10
FR-0-6	1"	1/2" thick wood fiberboard faced with 1/2" thick 1:2, 1:2 gypsum plaster	15 min	-	1	-	1-3	15
FR-0-7	1 3/8"	7/8" thick flameproofed wood fiberboard faced with 1/2" thick 1:2, 1:2 gypsum plaster	30 min	-	1	-	1-3	30
FR-0-8	1 1/4"	1 1/4" thick plywood	30 min	-	-	35	-	30

Table 1.5.2—Notes
Finish Ratings—Organic Materials

1. The finish rating is the time required to obtain an average temperature rise of 250°F, or a single point rise of 325°F, at the interface between the material being rated and the substrate being protected.
2. Tested in accordance with the Standard Specifications for Fire Tests of Building Construction and Materials, ASANo. A2-1932.
3. Plaster ratios as follows: first ratio is for scratch coat, weight of dry plaster to weight of dry sand; second ratio is for the brown coat.

General Note

The finish rating of thinner materials, particularly thinner woods, have not been listed because the possible effects of shrinkage, warpage, and aging cannot be predicted.

Section II—Columns

Table 2.1.1
Reinforced Concrete Columns
Minimum Dimension 0" (0 mm) to less than 6" (150 mm)

Item Code	Thick-ness	Construction Details	Performance		Reference Number			Notes	Rec Hours
			Load	Time	Pre BMS 92	BMS	Post-BMS 92		
C-6-RC-1	6"	6" x 6" square columns; gravel aggregate concrete (4030 psi); reinforcement—vertical 4 7/8" rebars; horizontal—5/16" ties @ 6" pitch; cover 1"	34.7 tons	62 min	-	-	7	1,2	1
C-6-RC-2	6"	6" x 6" square columns; gravel aggregate concrete (4200 psi); reinforcement—vertical 4 1/2" rebars; horizontal—5/16" ties @ 6" pitch; cover—1"	21 tons	69 min	-	-	7	1,2	1

Table 2.1.1—Notes

Reinforced Concrete Columns, Minimum Dimension 0" to less than 6"

1. Collapse.
2. British test.

Figure 2.1.2
Reinforced Concrete Columns,
Minimum Dimension 10" (250 mm) to less than 12" (300 mm)

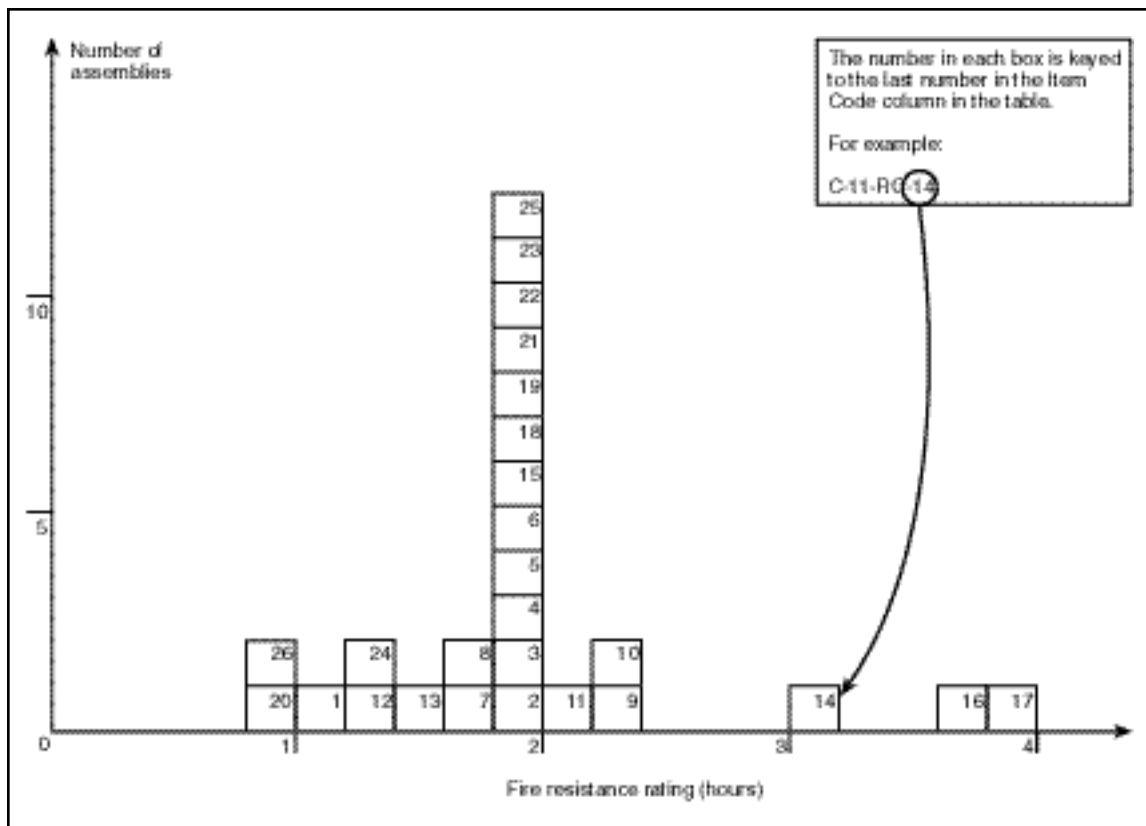

Table 2.1.2
Reinforced Concrete Columns
Minimum Dimension 10" (250 mm) to less than 12" (300 mm)

Item Code	Min. Dimen.	Construction Details	Performance		Reference Number			Notes	Rec Hours
			Load	Time	Pre BMS 92	BMS	Post-BMS 92		
C-10-RC-1	10"	10" square columns; aggregate concrete (4260 psi); reinforcement: vertical four 1 1/4" rebars; horizontal 3/8" ties @ 6" pitch; cover 1 1/4"	92.2 tons	1 hr 2 min	-	-	7	1	1
C-10-RC-2	10"	10" square columns; aggregate concrete (2325 psi); reinforcement: vertical four 1/2" rebars; horizontal 5/16" ties @ 6" pitch; cover 1"	46.7 tons	1 hr 52 min	-	-	7	1	1 3/4
C-10-RC-3	10"	10" square columns; aggregate concrete (5370 psi); reinforcement: vertical four 1/2" rebars; horizontal 5/16" ties @ 6" pitch; cover 1"	46.5 tons	2 hrs	-	-	7	2, 3, 11	2

Table 2.1.2, continued (Reinforced Concrete Columns, Minimum Dimension 10" to less than 12")

Item Code	Min. Dimen.	Construction Details	Performance		Reference Number			Notes	Rec Hours
			Load	Time	Pre BMS 92	BMS	Post-BMS 92		
C-10-RC-4	10"	10" square columns; aggregate concrete (5206 psi); reinforcement: vertical four 1/2" rebars; horizontal 5/16" ties @ 6" pitch; cover 1"	46.5 tons	2 hrs	-	-	7	2, 7	2
C-10-RC-5	10"	10" square columns; aggregate concrete (5674 psi); reinforcement: vertical four 1/2" rebars; horizontal 5/16" ties @ 6" pitch; cover 1"	46.7 tons	2 hrs	-	-	7	1	2
C-10-RC-6	10"	10" square columns; aggregate concrete (5150 psi); reinforcement: vertical four 1 1/2" rebars; horizontal 5/16" ties @ 6" pitch; cover 1"	66 tons	1 hr 43 min	-	-	7	1	1 3/4
C-10-RC-7	10"	10" square columns; aggregate concrete (5580 psi); reinforcement: vertical four 1/2" rebars; horizontal 5/16" ties @ 6" pitch; 1" cover	62.5 tons	1 hr 38 min	-	-	7	1	1 1/2
C-10-RC-8	10"	10" square columns; aggregate concrete (4080 psi); reinforcement: vertical four 1/8" rebars; horizontal 5/16" ties @ 6" pitch; 1 1/8" cover	72.8 tons	1 hr 48 min	-	-	7	1	1 3/4
C-10-RC-9	10"	10" square columns; aggregate concrete (2510 psi); reinforcement: vertical four 1/2" rebars; horizontal 5/16" ties @ 6" pitch; cover 1"	51 tons	2 hrs 16 min	-	-	7	1	2 1/4
C-10-RC-10	10"	10" square columns; aggregate concrete (2170 psi); reinforcement: vertical four 1/2" rebars; horizontal 5/16" ties @ 6" pitch; cover 1"	45 tons	2 hrs 14 min	-	-	7	12	2 1/4
C-10-RC-11	10"	10" square columns; gravel aggregate concrete (4015 psi); reinforcement: vertical four 1/2" rebars; horizontal 5/16" ties @ 6" pitch; cover 1"	46.5 tons	2 hrs 6 min	-	-	7	1	2
C-11-RC-12	11"	11" square columns; gravel aggregate concrete (4150 psi); reinforcement: vertical four 1 1/4" rebars; horizontal 3/8" ties @ 7 1/2" pitch, cover 1 1/2"	61 tons	1 hr 23 min	-	-	7	1	1 1/4
C-11-RC-13	11"	11" square columns; gravel aggregate concrete (4380 psi); reinforcement: vertical four 1 1/4" rebars; horizontal 3/8" ties @ 7 1/2" pitch; cover 1 1/2"	61 tons	1 hr 26 min	-	-	7	1	1 1/4
C-11-RC-14	11"	11" square columns; gravel aggregate concrete (4140 psi); reinforcement: vertical four 1 1/4" rebars; horizontal 3/8" ties @ 7 1/2" pitch; steel mesh around reinforcement; cover 1 1/2"	61 tons	3 hrs 9 min	-	-	7	1	3

Table 2.1.2, continued (Reinforced Concrete Columns, Minimum Dimension 10" to less than 12")

Item Code	Min. Dimen.	Construction Details	Performance		Reference Number			Notes	Rec Hours
			Load	Time	Pre BMS 92	BMS	Post-BMS 92		
C-11-RC-15	11"	11" square columns; slag aggregate concrete (3690 psi); reinforcement: vertical four 1 1/4" rebars; horizontal 3/8" ties @ 7 1/2" pitch; cover 1 1/2"	91 tons	2 hrs	-	-	7	2-5	2
C-11-RC-16	11"	11" square columns; limestone aggregate concrete (5230 psi); reinforcement: vertical four 1 1/4" rebars; horizontal 3/8" ties @ 7 1/2" pitch; cover 1 1/2"	91.5 tons	3 hrs 41 min	-	-	7	1	3 1/2
C-11-RC-17	11"	11" square columns; limestone aggregate concrete (5530 psi); reinforcement: vertical four 1 1/4" rebars; horizontal 3/8" ties @ 7 1/2" pitch; cover 1 1/2"	91.5 tons	3 hrs 47 min	-	-	7	1	3 1/2
C-11-RC-18	11"	11" square columns; limestone aggregate concrete (5280 psi); reinforcement: vertical four 1 1/4" rebars; horizontal 3/8" ties @ 7 1/2" pitch; cover 1 1/2"	91.5 tons	2 hrs	-	-	7	2-4,6	2
C-11-RC-19	11"	11" square columns; limestone aggregate concrete (4180 psi); reinforcement: vertical four 5/8" rebars; horizontal 3/8" ties @ 7" pitch; cover 1 1/2"	71.4 tons	2 hrs	-	-	7	2,7	2
C-11-RC-20	11"	11" square columns; gravel concrete (4530 psi); reinforcement: vertical four 5/8" rebars; horizontal 3/8" ties @ 7" pitch; cover 1 1/2" with 1/2" plaster	58.8 tons	2 hrs	-	-	7	2,3,9	1 1/4
C-11-RC-21	11"	11" square columns; gravel concrete (3520 psi); reinforcement: vertical four 5/8" rebars; horizontal 3/8" ties @ 7" pitch; cover 1 1/2"	variable	1 hr 24 min	-	-	7	1,8	2
C-11-RC-22	11"	11" square columns; aggregate concrete (3710 psi); reinforcement: vertical four 5/8" rebars; horizontal 3/8" ties @ 7" pitch; cover 1 1/2"	58.8 tons	2 hrs	-	-	7	2,3,10	2
C-11-RC-23	11"	11" square columns; aggregate concrete (3190 psi); reinforcement: vertical four 5/8" rebars; horizontal 3/8" ties @ 7" pitch; cover 1 1/2"	58.8 tons	2 hrs	-	-	7	2,3,10	2
C-11-RC-24	11"	11" square columns; aggregate concrete (4860 psi); reinforcement: vertical four 5/8" rebars; horizontal 3/8" ties @ 7" pitch; cover 1 1/2"	86.1 tons	1 hr 20 min	-	-	7	1	1 1/3
C-11-RC-25	11"	11" square columns; aggregate concrete (4850 psi); reinforcement: vertical four 5/8" rebars; horizontal 3/8" ties @ 7" pitch; cover 1 1/2"	58.8 tons	1 hr 59 min	-	-	7	1	1 3/4
C-11-RC-26	11"	11" square columns, aggregate concrete (3834 psi); reinforcement: vertical four 5/8" rebars; horizontal 5/16" ties @ 4 1/2" pitch; cover 1 1/2"	71.4 tons	53 min	-	-	7	1	3/4

Table 2.1.2—Notes

Reinforced Concrete Columns, Minimum Dimension 10" to less than 12"

1. Failure mode—collapse.
2. Passed 2-hr fire exposure.
3. Passed hose stream test.
4. Reloaded effectively after 48 hours but collapsed at load in excess of original test load.
5. Failing load was 150 tons.
6. Failing load was 112 tons.
7. Failed during hose stream test.
8. Range of load 58.8 tons (initial) to 92 tons (92 min.) to 60 tons (80 min.).
9. Collapsed at 44 tons in reload after 96 hours.
10. Withstood reload after 72 hours.
11. Collapsed on reload after 48 hours.

Table 2.1.3
Reinforced Concrete Columns
Minimum Dimension 12" (300 mm) to less than 14" (350 mm)

Item Code	Min. Dimen.	Construction Details	Performance		Reference Number			Notes	Rec Hours
			Load	Time	Pre BMS 92	BMS	Post-BMS 92		
C-12-RC-1	12"	12" square columns; gravel aggregate concrete (2647 psi); reinforcement: vertical 4—5/8" rebars; horizontal 5/16" ties @ 4 1/2" pitch; cover 2"	78.2 tons	38 min	-	1	7	1	1/2
C-12-RC-2	12"	Reinforced columns with 1 1/2 " concrete outside of reinforced steel; gross diameter or side of column: 12"; Group I, Column A	-	6 hrs	-	1	-	2,3	6
C-12-RC-3	12"	Description as per C-12-RC-2; Group I, Column B	-	4 hrs	-	1	-	2,3	4
C-12-RC-4	12"	Description as per C-12-RC-2; Group II, Column A	-	4 hrs	-	1	-	2,3	4
C-12-RC-5	12"	Description as per C-12-RC-2; Group II, Column B	-	2 hrs 30 min	-	1	-	2,3	2 1/2
C-12-RC-6	12"	Description as per C-12-RC-2; Group III, Column A	-	6 hrs	-	1	-	2,3	3
C-12-RC-7	12"	Description as per C-12-RC-2; Group III, Column B	-	2 hrs	-	1	-	2,3	2
C-12-RC-8	12"	Description as per C-12-RC-2; Group IV, Column A	-	2 hrs	-	1	-	2,3	2
C-12-RC-9	12"	Description as per C-12-RC-2; Group IV, Column B	-	1 hr 30 min	-	1	-	2,3	1 1/2

Table 2.1.3—Notes
Reinforced Concrete Columns, Minimum Dimension 12" to less than 14"

1. Failure mode—unspecified structural.
2. Group I—includes concrete having calcareous aggregate containing a combined total of not more than 10 percent of quartz, chert, and flint for the coarse aggregate.

Group II—includes concrete having trap-rock aggregate applied without metal ties and also concrete having cinder, sandstone, or granite aggregate, if held in place with wire mesh or expanded metal having not larger than 4-in. mesh, weighing not less than 1.7 lb/yd², placed not more than 1 in. from the surface of the concrete.

Group III—includes concrete having cinder, sandstone, or granite aggregate tied with No. 5 gauge steel wire, wound spirally over the column section on a pitch of 8 in., or equivalent ties, and concrete having siliceous aggregates containing a combined total of 60 percent or more of quartz,

chert, and flint, if held in place with wire mesh or expanded metal having not larger than 4-in. mesh, weighing not less than 1.7 lb/yd² placed not more than 1 in. from the surface of the concrete.

Group IV—includes concrete having siliceous aggregates containing a combined total of 60 percent or more of quartz, chert, and flint, and tied with No. 5 gauge steel wire wound spirally over the column section on a pitch of 8 in., or equivalent ties.

3. Groupings of aggregates and ties are the same as for structural steel columns protected solidly with concrete, the ties to be placed over the vertical reinforcing bars and the mesh, where required, to be placed within 1 in. from the surface of the column.

Column A—working loads are assumed as carried by the area of the column inside of the lines circumscribing the reinforcing steel.

Column B—working loads are assumed as carried by the gross area of the column.

Table 2.1.4
Reinforced Concrete Columns
Minimum Dimension 14" (350 mm) to less than 16" (400 mm)

Item Code	Min. Dimen.	Construction Details	Performance		Reference Number			Notes	Rec Hours
			Load	Time	Pre BMS 92	BMS	Post-BMS 92		
C-14-RC-1	14"	14" square columns; gravel aggregate concrete (4295 psi); reinforcement: vertical 4—3/4" rebars; horizontal 1/4" ties @ 9" pitch; cover 1 1/2"	86 tons	1 hr 22 min	-	-	7	1	1 1/4
C-14-RC-2	14"	Reinforced concrete columns with 1 1/2" concrete outside reinforcing steel; gross diameter or side of column 14"; Group I, Column A	-	7 hrs	-	1	-	2,3	7
C-14-RC-3	14"	Description as per C-14-RC-2; Group II, Column B	-	5 hrs	-	1	-	2,3	5
C-14-RC-4	14"	Description as per C-14-RC-2; Group III, Column A	-	5 hrs	-	1	-	2,3	5
C-14-RC-5	14"	Description as per C-14-RC-2; Group IV, Column B	-	3 hrs 30 min	-	1	-	2,3	3 1/2
C-14-RC-6	14"	Description as per C-14-RC-2; Group III, Column A	-	4 hrs	-	1	-	2,3	4
C-14-RC-7	14"	Description as per C-14-RC-2; Group III, Column B	-	2 hrs 30 min	-	1	-	2,3	2 1/2
C-14-RC-8	14"	Description as per C-14-RC-2; Group IV, Column A	-	2 hrs 30 min	-	1	-	2,3	2 1/2
C-14-RC-9	14"	Description as per item C-14-RC-2; Group IV, Column B	-	1 hr 30 min	-	1	-	2,3	1 1/2

Table 2.1.4—Notes
Reinforced Concrete Columns, Minimum Dimension 14" to less than 16"

1. Failure mode—main rebars buckled between links at various points.
2. Group I—includes concrete having calcareous aggregate containing a combined total of not more than 10 percent of quartz, chert, and flint for the coarse aggregate.

Group II—includes concrete having trap-rock aggregate applied without metal ties and also concrete having cinder, sandstone, or granite aggregate, if held in place with wire mesh or expanded metal having not larger than 4-in. mesh, weighing not less than 1.7 lb/yd², placed not more than 1 in. from the surface of the concrete.

Group III—includes concrete having cinder, sandstone, or granite aggregate tied with No. 5 gauge steel wire, wound spirally over the column section on a pitch of 8 in., or equivalent ties, and concrete having siliceous aggregates containing a combined total of 60 percent or more of quartz, chert, and flint, if held in place with wire mesh or expanded metal having

not larger than 4-in. mesh, weighing not less than 1.7 lb/yd² placed not more than 1 in. from the surface of the concrete.

Group IV—includes concrete having siliceous aggregates containing a combined total of 60 percent or more of quartz, chert, and flint, and tied with No. 5 gauge steel wire wound spirally over the column section on a pitch of 8 in., or equivalent ties.

3. Groupings of aggregates and ties are the same as for structural steel columns protected solidly with concrete, the ties to be placed over the vertical reinforcing bars and the mesh, where required, to be placed within 1 in. from the surface of the column.

Column A—working loads are assumed as carried by the area of the column inside of the lines circumscribing the reinforcing steel.

Column B—working loads are assumed as carried by the gross area of the column.

Figure 2.1.5
Reinforced Concrete Columns
Minimum Dimension 16" (400 mm) to less than 18" (450 mm)

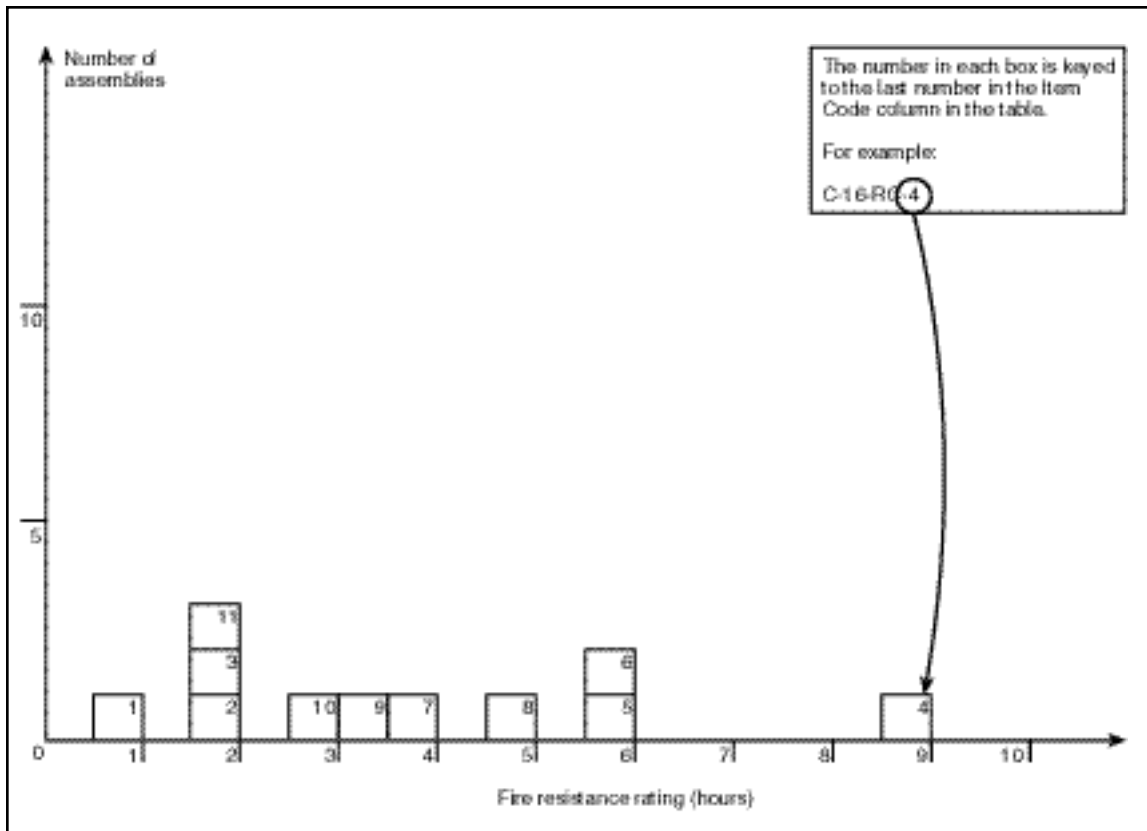

Table 2.1.5
Reinforced Concrete Columns
Minimum Dimension 16" (400 mm) to less than 18" (450 mm)

Item Code	Min. Dimen.	Construction Details	Performance		Reference Number			Notes	Rec Hours
			Load	Time	Pre BMS 92	BMS	Post-BMS 92		
C-16-RC-1	16"	16" square columns; gravel aggregate concrete (4550 psi); reinforcement: vertical 8—1 3/8" rebar; horizontal 5/16" ties @ 6" pitch 1 3/8" below column surfaces and 5/16" ties @ 6" pitch linking center rebar of each face forming a smaller square in column cross section	237 tons	1 hr	-	-	7	1-3	1
C-16-RC-2	16"	16" square columns; gravel aggregate concrete (3360 psi); reinforcement: vertical 8—1 3/8" rebar; horizontal 5/16" ties @ 6" pitch; cover 1 3/8"	210 tons	2 hrs	-	-	7	2,4-6	2
C-16-RC-3	16"	16" square columns; gravel aggregate concrete (3980 psi); reinforcement: vertical 4—7/8" rebar; horizontal 3/8" ties @ 6" pitch; cover 1"	123.5 tons	2 hrs	-	-	7	2,4,7	2
C-16-RC-4	16"	Reinforced concrete columns with 1 1/2" concrete outside reinforcing steel; gross diameter or side of column: 16"; Group I, Column A	-	9 hrs	-	1	-	8,9	9
C-16-RC-5	16"	Description as per C-16-RC-4; Group I, Column B	-	6 hrs	-	1	-	8,9	6
C-16-RC-6	16"	Description as per C-16-RC-4; Group II, Column A	-	6 hrs	-	1	-	8,9	6
C-16-RC-7	16"	Description as per C-16-RC-4; Group II, Column B	-	4 hrs	-	1	-	8,9	4
C-16-RC-8	16"	Description as per C-16-RC-4; Group III, Column A	-	5 hrs	-	1	-	8,9	5
C-16-RC-9	16"	Description as per C-16-RC-4; Group III, Column B	-	3 hrs 30 min	-	1	-	8,9	3 1/2
C-16-RC-10	16"	Description as per C-16-RC-4; Group IV, Column A	-	3 hrs	-	1	-	8,9	3
C-16-RC-11	16"	Description as per C-16-RC-4; Group IV, Column B	-	2 hrs	-	1	-	8,9	2

Table 2.1.5—Notes
Reinforced Concrete Columns, Minimum Dimension 16" to less than 18"

1. Column passed 1-hr fire test.
2. Column passed hose stream test.
3. No reload specified.
4. Column passed 2-hr fire test.
5. Column reloaded successfully after 24 hours.
6. Reinforcing details same as C-16-RC-1.
7. Column passed reload after 72 hours.
8. Group I—includes concrete having calcareous aggregate containing a combined total of not more than 10 percent of quartz, chert, and flint for the coarse aggregate.

Table 2.1.5—Notes, continued

Group II—includes concrete having trap-rock aggregate applied without metal ties and also concrete having cinder, sandstone, or granite aggregate, if held in place with wire mesh or expanded metal having not larger than 4-in. mesh, weighing not less than 1.7 lb/yd², placed not more than 1 in. from the surface of the concrete.

Group III—includes concrete having cinder, sandstone, or granite aggregate tied with No. 5 gauge steel wire, wound spirally over the column section on a pitch of 8 in., or equivalent ties, and concrete having siliceous aggregates containing a combined total of 60 percent or more of quartz, chert, and flint, if held in place with wire mesh or expanded metal having not larger than 4-in. mesh, weighing not less than 1.7 lb/yd², placed not more than 1 in. from the surface of the concrete.

Group IV—includes concrete having siliceous aggregates containing a combined total of 60 percent or more of quartz, chert, and flint, and tied with No. 5 gauge steel wire wound spirally over the column section on a pitch of 8 in., or equivalent ties.

9. Groupings of aggregates and ties are the same as for structural steel columns protected solidly with concrete, the ties to be placed over the vertical reinforcing bars and the mesh, where required, to be placed within 1 in. from the surface of the column.

Column A—working loads are assumed as carried by the area of the column inside of the lines circumscribing the reinforcing steel.

Column B—working loads are assumed as carried by the gross area of the column.

Table 2.1.6
Reinforced Concrete Columns
Minimum Dimension 18" (450 mm) to less than 20" (500 mm)

Item Code	Min. Dimen.	Construction Details	Performance		Reference Number			Notes	Rec Hours
			Load	Time	Pre BMS 92	BMS	Post-BMS 92		
C-18-RC-1	18"	Reinforced concrete columns with 1 1/2" concrete outside reinforced steel; gross diameter or side of column: 18"; Group I, Column A	-	11 hrs	-	1	-	1,2	11
C-18-RC-2	18"	Description as per C-18-RC-1; Group I, Column B	-	8 hrs	-	1	-	1,2	8
C-18-RC-3	18"	Description as per C-18-RC-1; Group II, Column A	-	7 hrs	-	1	-	1,2	7
C-18-RC-4	18"	Description as per C-18-RC-1; Group II, Column B	-	5 hrs	-	1	-	1,2	5
C-18-RC-5	18"	Description as per C-18-RC-1; Group III, Column A	-	6 hrs	-	1	-	1,2	6
C-18-RC-6	18"	Description as per C-18-RC-1; Group III, Column B	-	4 hrs	-	1	-	1,2	4
C-18-RC-7	18"	Description as per C-18-RC-1; Group IV, Column A	-	3 hrs 30 min	-	1	-	1,2	3 1/2
C-18-RC-8	18"	Description as per C-18-RC-1; Group IV, Column B	-	2 hrs 30 min	-	1	-	1,2	2 1/2

Table 2.1.6—Notes
Reinforced Concrete Columns, Minimum Dimension 18" to less than 20"

1. Group I—includes concrete having calcareous aggregate containing a combined total of not more than 10 percent of quartz, chert, and flint for the coarse aggregate.

Group II—includes concrete having trap-rock aggregate applied without metal ties and also concrete having cinder, sandstone, or granite aggregate, if held in place with wire mesh or expanded metal having not larger than 4-in. mesh, weighing not less than 1.7 lb/yd², placed not more than 1 in. from the surface of the concrete.

Group III—includes concrete having cinder, sandstone, or granite aggregate tied with No. 5 gauge steel wire, wound spirally over the column section on a pitch of 8 in., or equivalent ties, and concrete having siliceous aggregates containing a combined total of 60 percent or more of quartz, chert, and flint, if held in place with wire mesh or expanded metal having

not larger than 4-in. mesh, weighing not less than 1.7 lb/yd², placed not more than 1 in. from the surface of the concrete.

Group IV—includes concrete having siliceous aggregates containing a combined total of 60 percent or more of quartz, chert, and flint, and tied with No. 5 gauge steel wire wound spirally over the column section on a pitch of 8 in., or equivalent ties.

2. Groupings of aggregates and ties are the same as for structural steel columns protected solidly with concrete, the ties to be placed over the vertical reinforcing bars and the mesh, where required, to be placed within 1 in. from the surface of the column.

Column A—working loads are assumed as carried by the area of the column inside of the lines circumscribing the reinforcing steel.

Column B—working loads are assumed as carried by the gross area of the column.

Figure 2.1.7
Reinforced Concrete Columns
Minimum Dimension 20" (500 mm) to less than 22" (550 mm)

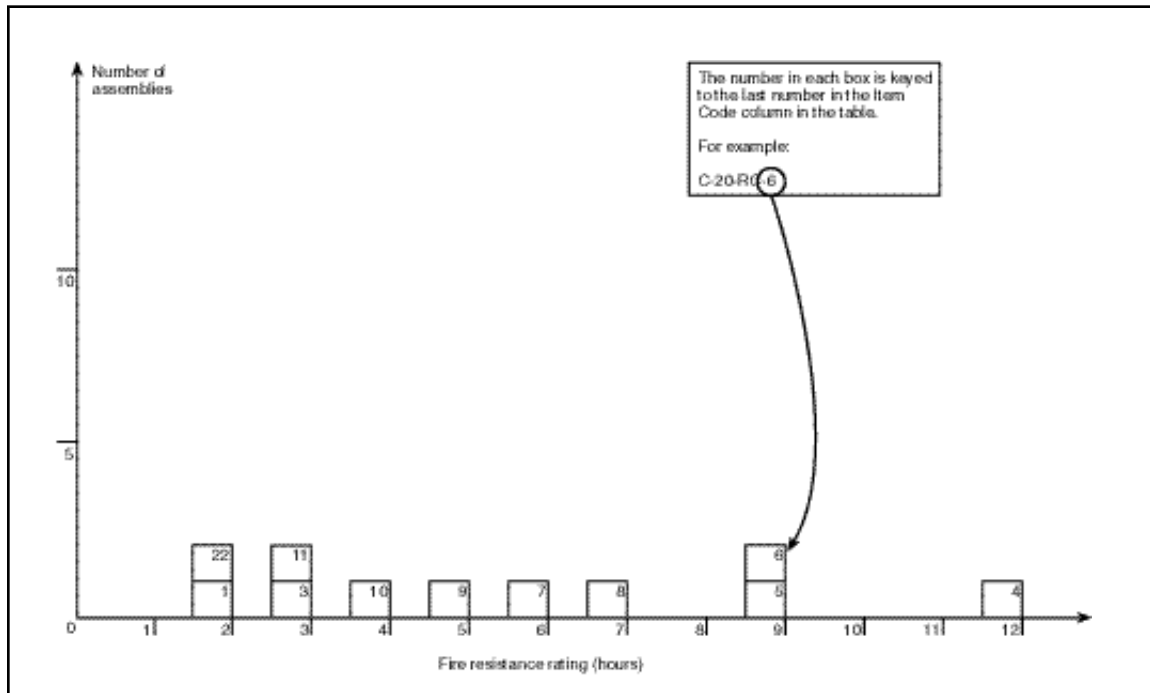

Table 2.1.7
Reinforced Concrete Columns
Minimum Dimension 20" (500 mm) to less than 22" (550 mm)

Item Code	Min. Dimen.	Construction Details	Performance		Reference Number			Notes	Rec Hours
			Load	Time	Pre BMS 92	BMS	Post-BMS 92		
C-20-RC-1	20"	20" square columns; gravel aggregate concrete (6690 psi); reinforcement: vertical 4—1 3/4" rebars; horizontal 3/8" wire @ 6" pitch; cover 1 3/4"	367 tons	2 hrs	-	-	7	1-3	2
C-20-RC-2	20"	20" square columns; gravel aggregate concrete (4330 psi); reinforcement: vertical 4—1 3/4" rebars; horizontal 3/8" ties @ 6" pitch; cover 1 3/4"	327 tons	2 hrs	-	-	7	1,2,4	2
C-20-RC-3	20 1/4"	20 1/4" square columns; gravel aggregate concrete (4230 psi); reinforcement: vertical 4—1 1/8" rebars; horizontal 3/8" wire @ 5" pitch; cover 1 1/8"	199 tons	2 hrs 56 min	-	-	7	5	2 3/4
C-20-RC-4	20"	Reinforced concrete columns with 1 1/2" concrete outside of reinforcing steel; gross diameter or side of column: 20"; Group I, Column A	-	12 hrs	-	1	-	6,7	12
C-20-RC-5	20"	Description as per C-20-RC-4; Group I, Column B	-	9 hrs	-	1	-	6,7	9
C-20-RC-6	20"	Description as per C-20-RC-4; Group II, Column A	-	9 hrs	-	1	-	6,7	9
C-20-RC-7	20"	Description as per C-20-RC-4; Group II, Column B	-	6 hrs	-	1	-	6,7	6
C-20-RC-8	20"	Description as per C-20-RC-4; Group III, Column A	-	7 hrs	-	1	-	6,7	7
C-20-RC-9	20"	Description as per C-20-RC-4; Group III, Column B	-	5 hrs	-	1	-	6,7	5
C-20-RC-10	20"	Description as per C-20-RC-4; Group IV, Column A	-	4 hrs	-	1	-	6,7	4
C-20-RC-11	20"	Description as per C-20-RC-4; Group IV, Column B	-	5 hrs	-	1	-	6,7	3

Table 2.1.7—Notes

Reinforced Concrete Columns, Minimum Dimension 20" to less than 22"

1. Passed 2-hr fire test.
2. Passed hose stream test.
3. Failed during reload at 300 tons.
4. Passed reload after 72 hours.
5. Failure mode—collapse.
6. Group I—includes concrete having calcareous aggregate containing a combined total of not more than 10 percent of quartz, chert, and flint for the coarse aggregate.

Group II—includes concrete having trap-rock aggregate applied without metal ties and also concrete having cinder, sandstone, or granite aggregate, if held in place with wire mesh or expanded metal having not larger than 4-in. mesh, weighing not less than 1.7 lb/yd², placed not more than 1 in. from the surface of the concrete.

Group III—includes concrete having cinder, sandstone, or granite aggregate tied with No. 5 gauge steel wire, wound spirally over the column section on a pitch of 8 in., or equivalent ties, and concrete having siliceous aggregates containing a combined total of 60 percent or more of quartz, chert, and flint, if held in place with wire mesh or expanded metal having not larger than 4-in. mesh, weighing not less than 1.7 lb/yd², placed not more than 1 in. from the surface of the concrete.

Group IV—includes concrete having siliceous aggregates containing a combined total of 60 percent or more of quartz, chert, and flint, and tied with No. 5 gauge steel wire wound spirally over the column section on a pitch of 8 in., or equivalent ties.

7. Groupings of aggregates and ties are the same as for structural steel columns protected solidly with concrete, the ties to be placed over the vertical reinforcing bars and the mesh, where required, to be placed within 1 in. from the surface of the column.

Column A—working loads are assumed as carried by the area of the column inside of the lines circumscribing the reinforcing steel.

Column B—working loads are assumed as carried by the gross area of the column.

Table 2.1.8
Hexagonal Reinforced Concrete Columns
Minimum Dimension 12" (300 mm) to less than 14" (350 mm)

Item Code	Min. Dimen.	Construction Details	Performance		Reference Number			Notes	Rec Hours
			Load	Time	Pre BMS 92	BMS	Post-BMS 92		
C-12-HRC-1	12"	12" hexagonal columns; gravel aggregate concrete (4420 psi); vertical reinforcement: 8 1/2" rebars; horizontal reinforcement: helical 5/16" winding @ 1 1/2" pitch; cover 1/2"	88 tons	58 min	-	-	7	1	3/4
C-12-HRC-2	12"	12" hexagonal columns; gravel aggregate concrete (3460 psi); vertical reinforcement 8—1/2" rebars; horizontal reinforcement: 5/16" helical winding @ 1 1/2" pitch; cover 1/2"	78.7 tons	1 hr	-	-	7	2	1

Table 2.1.8—Notes

Hexagonal Reinforced Concrete Columns, Minimum Dimension 12" to less than 14"

1. Failure mode—collapse.
2. Test stopped at 1 hour.

Table 2.1.9
Hexagonal Reinforced Concrete Columns
Minimum Dimension 14" (350 mm) to less than 16" (400 mm)

Item Code	Min. Dimen.	Construction Details	Performance		Reference Number			Notes	Rec Hours
			Load	Time	Pre BMS 92	BMS	Post-BMS 92		
C-14-HRC-1	14"	14" hexagonal columns; gravel aggregate concrete (4970 psi); vertical reinforcement 8—1/2" rebar; horizontal reinforcement: 5/16" helical winding on 2" pitch; cover 1/2"	90 tons	2 hrs	-	-	7	1-3	2

Table 2.1.9—Notes
Hexagonal Reinforced Concrete Columns, Minimum Dimension 14" to less than 16"

1. Withstood 2-hr fire test.
2. Withstood hose stream test.
3. Withstood reload after 48 hours.

Table 2.1.10
Hexagonal Reinforced Concrete Columns
Minimum Dimension—16" (400 mm) to less than 18" (450 mm)

Item Code	Min. Dimen.	Construction Details	Performance		Reference Number			Notes	Rec Hours
			Load	Time	Pre BMS 92	BMS	Post-BMS 92		
C-16-HRC-1	16"	16" hexagonal columns; gravel concrete (6320 psi); vertical reinforcement: 8—5/8" rebar; horizontal reinforcement: 5/16" helical winding on 3/4" pitch; cover 1/2"	140 tons	1 hr 55 min	-	-	7	1	1 3/4
C-16-HRC-2	16"	16" hexagonal columns; gravel aggregate concrete (5580 psi); vertical reinforcement 8—5/8" rebar; horizontal reinforcement 5/16" helical winding on 1 3/4" pitch; cover 1/2"	124 tons	2 hrs	-	-	7	2	2

Table 2.1.10—Notes
Hexagonal Reinforced Concrete Columns, Diameter—16" to less than 18"

1. Failure mode—collapse.
2. Failed on furnace removal.

Table 2.1.11
Hexagonal Reinforced Concrete Columns
Minimum Dimension—20" (500 mm) to less than 22" (550 mm)

Item Code	Min. Dimen.	Construction Details	Performance		Reference Number			Notes	Rec Hours
			Load	Time	Pre BMS 92	BMS	Post-BMS 92		
C-20-HRC-1	20"	20" hexagonal columns; gravel concrete (6080 psi); vertical reinforcement: 3/4" rebar; horizontal reinforcement: 5/16" helical winding on 1 3/4" pitch; cover 1/2"	211 tons	2 hrs	-	-	7	1	2
C-20-HRC-2	20"	20" hexagonal columns; gravel concrete (5080 psi); vertical reinforcement: 3/4" rebar; horizontal reinforcement: 5/16" wire on 1 3/4" pitch; cover 1/2"	184 tons	2 hrs 15 min	-	-	7	2,3,4	2 1/4

Table 2.1.11—Notes

Hexagonal Reinforced Concrete Columns, Diameter—20" to less than 22"

1. Column collapsed on furnace removal.

2. Passed 2 1/4-hr fire test.

3. Passed hose stream test.

4. Withstood reload after 48 hours.

Table 2.2
Round Cast Iron Columns

Item Code	Min. Dimen.	Construction Details	Performance		Reference Number			Notes	Rec Hours
			Load	Time	Pre BMS 92	BMS	Post-BMS 92		
C-7-CI-1	7" O.D.	Column: 0.6" minimum thickness metal, unprotected	-	30 min	-	1	-	-	1/2
C-7-CI-2	7" O.D.	Column: 0.6" minimum metal thickness concrete filled, outside unprotected	-	45 min	-	1	-	-	3/4
C-11-CI-3	11" O.D.	Column: 0.6" minimum metal thickness; protection: 1 1/2" portland cement plaster on high ribbed metal lath, 1/2" broken air space	-	3 hrs	-	1	-	-	3
C-11-CI-4	11" O.D.	Column: 0.6" minimum metal thickness; protection: 2" concrete other than siliceous aggregate	-	2 hrs 30 min	-	1	-	-	2 1/2
C-12-CI-5	12 1/2" O.D.	Column: 7" O.D., 0.6" minimum metal thickness; protection: 2" porous hollow tile, 3/4" mortar between tile and column, outside wire ties	-	3 hrs	-	1	-	-	3
C-7-CI-6	7.6" O.D.	Column: 7" I.D., 3/10" minimum thickness metal, concrete filled unprotected	-	30 min	-	1	-	-	1/2
C-7-CI-7	8.6" O.D.	Column: 8" I.D., 3/10" minimum thickness metal, concrete filled reinforced with 4—3 1/2" x 3/8" angles, in fill; unprotected outside	-	1 hr	-	1	-	-	1

Figure 2.3
Steel Columns—Gypsum Encasements

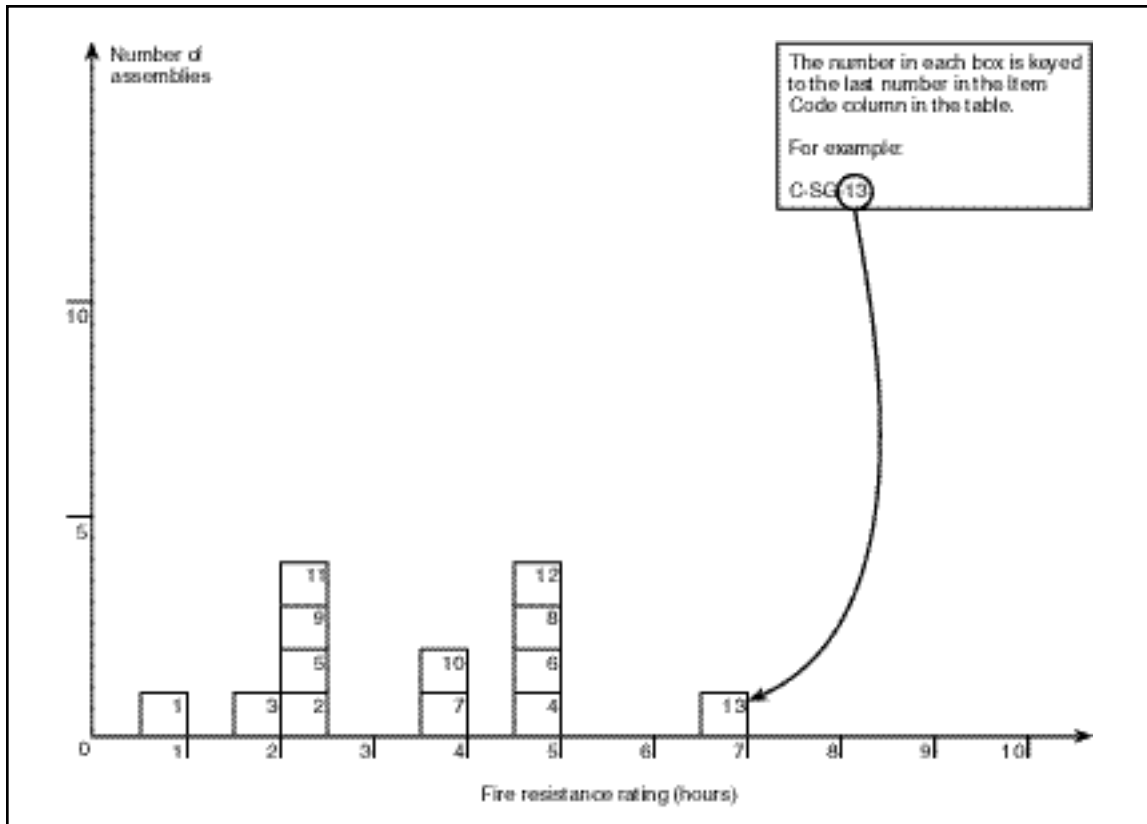

Table 2.3
Steel Columns—Gypsum Encasements

Item Code	Min. Area of Solid Material	Construction Details	Performance		Reference Number			Notes	Rec Hours
			Load	Time	Pre BMS 92	BMS	Post-BMS 92		
C-SG-1	-	Steel protected with 3/4" 1:3 sanded gypsum or 1" 1:2 1/2 portland cement plaster on wire or lath; one layer	-	1 hr	-	1	-	-	1
C-SG-2	-	Same as C-SG-1; two layers	-	2 hrs 30 min	-	1	-	-	2 1/2
C-SG-3	130 in. ²	2" solid blocks with wire mesh in horizontal joints, 1" mortar on flange, reentrant space filled with block and mortar	-	2 hrs	-	1	-	-	2
C-SG-4	150 in. ²	Same as C-130-SG-3 with 1/2" sanded gypsum plaster	-	5 hrs	-	1	-	-	5

Table 2.3, continued (Steel Columns—Gypsum Encasements)

Item Code	Min. Area of Solid Material	Construction Details	Performance		Reference Number			Notes	Rec Hours
			Load	Time	Pre BMS 92	BMS	Post-BMS 92		
C-SG-5	130 in. ²	2" solid blocks with wire mesh in horizontal joints, 1" mortar on flange, reentrant space filled with gypsum concrete	-	2 hrs 30 min	-	1	-	-	2 1/2
C-SG-6	150 in. ²	Same as C-130-SG-5 with 1/2" sanded gypsum plaster	-	5 hrs	-	1	-	-	5
C-SG-7	300 in. ²	4" solid blocks with wire mesh in horizontal joints, 1" mortar on flange, reentrant space filled with block and mortar	-	4 hrs	-	1	-	-	4
C-SG-8	300 in. ²	Same as C-300-SG-7 with reentrant space filled with gypsum concrete	-	5 hrs	-	1	-	-	5
C-SG-9	85 in. ²	2" solid blocks with cramps at horizontal joints, mortar on flange only at horizontal joints, reentrant space not filled	-	2 hrs 30 min	-	1	-	-	2 1/2
C-SG-10	105 in. ²	Same as C-85-SG-9 with 1/2" sanded gypsum plaster	-	4 hrs	-	1	-	-	4
C-SG-11	95 in. ²	3" hollow blocks with cramps at horizontal joints, mortar on flange only at horizontal joints, reentrant space not filled	-	2 hrs 30 min	-	1	-	-	2 1/2
C-SG-12	120 in. ²	Same as C-95-SG-11 with 1/2" sanded gypsum plaster	-	5 hrs	-	1	-	-	5
C-SG-13	130 in. ²	2" neat fibered gypsum reentrant space filled poured solid and reinforced with 4" x 4" wire mesh 1/2" sanded gypsum plaster	-	7 hrs	-	1	--	-	7

Table 2.4
Timber Columns, Minimum Dimension

Item Code	Min. Dimen.	Construction Details	Performance		Reference Number			Notes	Rec Hours
			Load	Time	Pre BMS 92	BMS	Post-BMS 92		
C-11-TC-1	11"	With unprotected steel plate cap	-	30 min	-	1	-	1,2	1/2
C-11-TC-2	11"	With unprotected cast iron cap and pintle	-	45 min	-	1	-	1,2	3/4
C-11-TC-3	11"	With concrete or protected steel or cast iron cap	-	1 hr 15 min	-	1	-	1,2	1 1/4
C-11-TC-4	11"	With 3/8" gypsum wallboard over column and over cast iron or steel cap	-	1 hr 15 min	-	1	-	1,2	1 1/4
C-11-TC-5	11"	With 1" portland cement plaster on wire lath over column and over cast iron or steel cap; 3/4" air space	-	2 hrs	-	1	-	1,2	2

Table 2.4—Notes
Timber Columns, Minimum Dimension

1. Minimum area: 120 in²
2. Type of wood: Long leaf pine or Douglas fir.

Table 2.5.1.1
Steel Columns—Concrete Encasements
Minimum Dimension less than 6" (150 mm)

Item Code	Min. Dimen.	Construction Details	Performance		Reference Number			Notes	Rec Hours
			Load	Time	Pre BMS 92	BMS	Post-BMS 92		
C-5-SC-1	5"	5" x 6" outer dimensions; 4" x 3" x 10 lb—H beam; protection: gravel concrete (4900 psi) 6" x 4"—13 SWG mesh	12 tons	1 hr 29 min	-	-	7	1	1 1/4

Table 2.5.1.1—Notes
Steel Columns—Concrete Encasements
Minimum Dimension less than 6"

1. Failure mode—collapse.

Table 2.5.1.2
Steel Columns—Concrete Encasements 6" (150 mm) to less than 8" (200 mm) thick

Item Code	Min. Dimen.	Construction Details	Performance		Reference Number			Notes	Rec Hours
			Load	Time	Pre BMS 92	BMS	Post-BMS 92		
C-7-SC-1	7"	7" x 8" column; 4" x 3" x 10 lb H beam; protection: brick-filled concrete (6220 psi); 6" x 4" mesh—13 SWG; mesh 1" below column surface	12 tons	2 hrs 46 min	-	-	7	1	3
C-7-SC-2	7"	7" x 8" column; 4" x 3" x 10 lb H beam; protection: gravel concrete (5140 psi); 6" x 4"—13 SWG mesh 1" below surface	12 tons	3 hrs 1 min	-	-	7	1	2 3/4
C-7-SC-3	7"	7" x 8" column; 4" x 3" x 10 lb H beam; protection: concrete (4540 psi); 6" x 4"—13 SWG mesh; 1" below column surface	12 tons	3 hrs 9 min	-	-	7	1	3
C-7-SC-4	7"	7" x 8" column; 4" x 3" 10 lb H beam; protection: gravel concrete (5520 psi); 4" x 4"; 16 SWG mesh	12 tons	2 hrs 50 min	-	-	7	1	2 3/4

Table 2.5.1.2—Notes

Steel Columns—Concrete Encasements 6" to less than 8" thick

1. Failure mode—collapse.

Figure 2.5.1.3
Steel Columns—Concrete Encasements
Minimum Dimension 8" (200 mm) to less than 10" (250 mm)

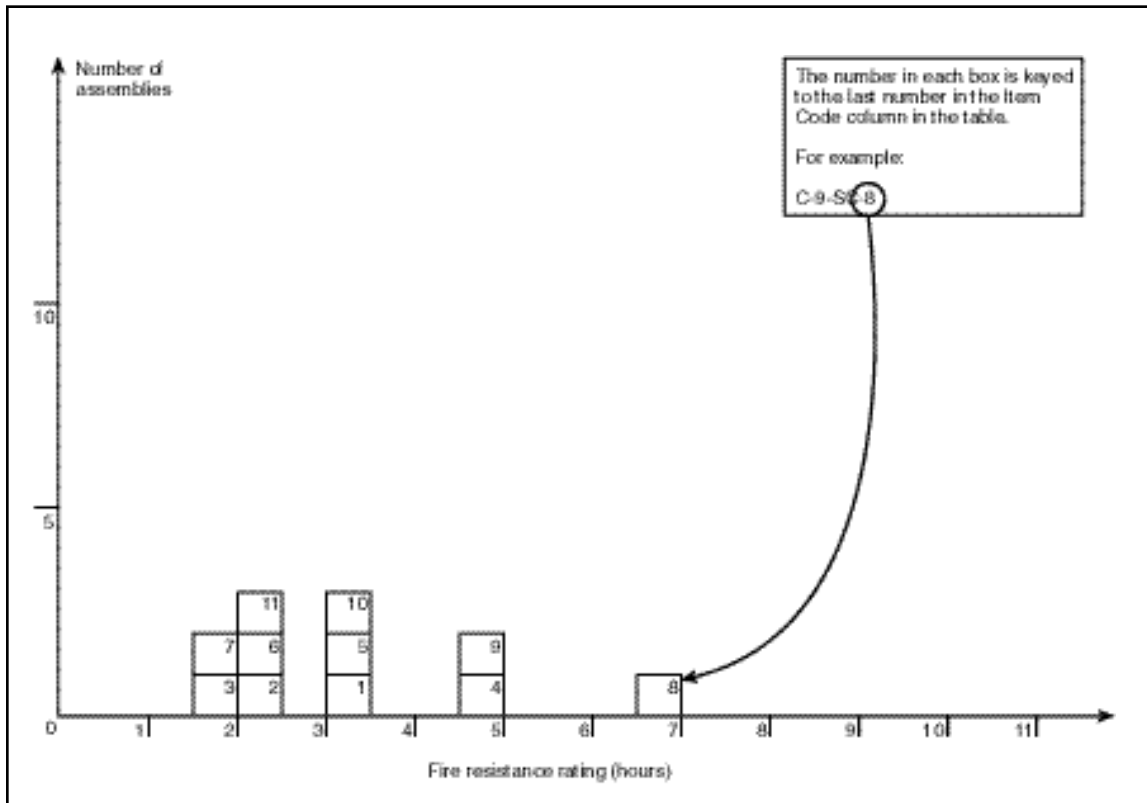

Table 2.5.1.3
Steel Columns—Concrete Encasements
Minimum Dimension 8" (200 mm) to less than 10" (250 mm)

Item Code	Min. Dimen.	Construction Details	Performance		Reference Number			Notes	Rec Hours
			Load	Time	Pre BMS 92	BMS	Post-BMS 92		
C-8-SC-1	8 1/2"	8 1/2" x 10" column; 6" x 4 1/2" x 20 lb H beam; protection: gravel concrete (5140 psi) 6" x 4"—13 SWG mesh	39 tons	3 hrs 8 min	-	-	7	1	3
C-8-SC-2	8"	8" x 10" column; 8" x 6" x 35 lb I beam; protection: gravel concrete (4240 psi) 4" x 6"—13 SWG mesh with 1/2" cover	90 tons	2 hrs 1 min	-	-	7	1	2

Table 2.5.1.3, continued (Steel Columns—Concrete Encasements, Minimum Dimension 8" to less than 10")

Item Code	Min. Dimen.	Construction Details	Performance		Reference Number			Notes	Rec Hours
			Load	Time	Pre BMS 92	BMS	Post-BMS 92		
C-8-SC-3	8"	8" x 10" concrete encased column; 8" x 6" x 35 lb H beam; protection: aggregate concrete (3750 psi) with 4"—16 SWG mesh, reinforcing 1/2" below column surface	90 tons	1 hr 58 min	-	-	7	1	1 3/4
C-8-SC-4	8"	6" x 6" steel column with 2" outside protection; Group I	-	5 hrs	-	1	-	2	5
C-8-SC-5	8"	6" x 6" steel column with 2" outside protection; Group II	-	3 hrs 30 min	-	1	-	2	3 1/2
C-8-SC-6	8"	6" x 6" steel column with 2" outside protection; Group III	-	2 hrs 30 min	-	1	-	2	2 1/2
C-8-SC-7	8"	6" x 6" steel column with 2" outside protection; Group IV	-	1 hr 45 min	-	1	-	2	1 3/4
C-9-SC-8	9"	6" x 6" steel column with 3" outside protection; Group I	-	7 hrs	-	1	-	2	7
C-9-SC-9	9"	6" x 6" steel column with 3" outside protection; Group II	-	5 hrs	-	1	-	2	5
C-9-SC-10	9"	6" x 6" steel column with 3" outside protection; Group III	-	3 hrs 30 min	-	1	-	2	3 1/2
C-9-SC-11	9"	6" x 6" steel column with 3" outside protection; Group IV	-	2 hrs 30 min	-	1	-	2	2 1/2

Table 2.5.1.3—Notes**Steel Columns—Concrete Encasements
Minimum Dimension 8" to less than 10"**

1. Failure mode—collapse.
2. Group I—includes concrete having calcareous aggregate containing a combined total of not more than 10 percent of quartz, chert, and flint for the coarse aggregate.

Group II—includes concrete having trap-rock aggregate applied without metal ties and also concrete having cinder, sandstone, or granite aggregate, if held in place with wire mesh or expanded metal having not larger than 4-in. mesh, weighing not less than 1.7 lb/yd², placed not more than 1 in. from the surface of the concrete.

Group III—includes concrete having cinder, sandstone, or granite aggregate tied with No. 5 gauge steel wire, wound spirally over the column section on a pitch of 8 in., or equivalent ties, and concrete having siliceous aggregates containing a combined total of 60 percent or more of quartz, chert, and flint, if held in place with wire mesh or expanded metal having not larger than 4-in. mesh, weighing not less than 1.7 lb/yd², placed not more than 1 in. from the surface of the concrete.

Group IV—includes concrete having siliceous aggregates containing a combined total of 60 percent or more of quartz, chert, and flint, and ties with No. 5 gauge steel wire wound spirally over the column section on a pitch of 8 in., or equivalent ties.

Figure 2.5.1.4
Steel Columns—Concrete Encasements
Minimum Dimension 10" (250mm) to less than 12" (300 mm)

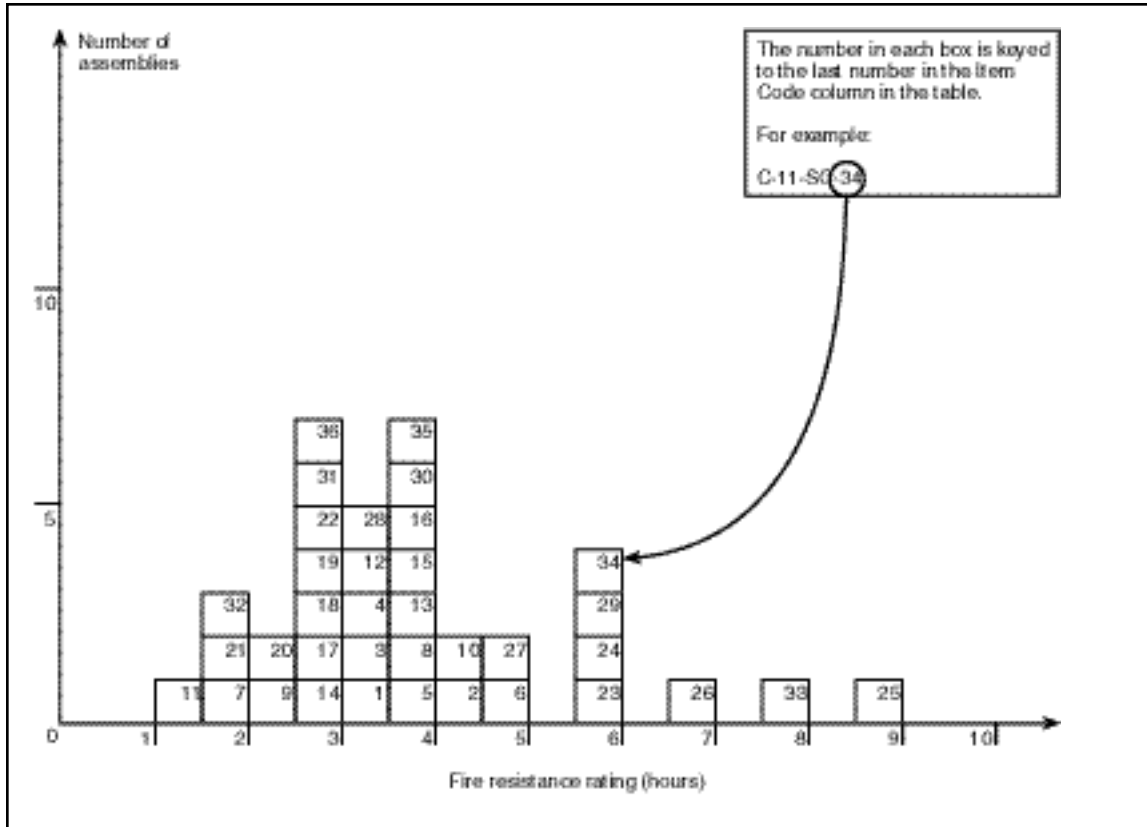

Table 2.5.1.4
Steel Columns—Concrete Encasements
Minimum Dimension 10" (250 mm) to less than 12" (300 mm)

Item Code	Min. Dimen.	Construction Details	Performance		Reference Number			Notes	Rec Hours
			Load	Time	Pre BMS 92	BMS	Post-BMS 92		
C-10-SC-1	10"	10" x 12" concrete encased steel column; 8" x 6" x 35 lb H beam; protection: gravel aggregate concrete (3640 psi); 6" x 4"—13 SWG mesh, 1" below column surface	90 tons	3 hrs 7 min	-	-	7	1,2	3
C-10-SC-2	10"	Column: 10" x 16"; 8" x 6" x 35 lb H beam; protection: clay brick concrete (3630 psi); 6" x 4"—13 SWG mesh; 1" below column surface	90 tons	4 hrs 6 min	-	-	7	2	4

Table 2.5.1.4, continued (Steel Columns—Concrete Encasements, Minimum Dimension 10" to less than 12")

Item Code	Min. Dimen.	Construction Details	Performance		Reference Number			Notes	Rec Hours
			Load	Time	Pre BMS 92	BMS	Post-BMS 92		
C-10-SC-3	10"	Column: 10" x 12"; 8" x 6" x 35 lb H beam; protection: concrete of crushed stone and sand (3930 psi) 6" x 4"—13 SWG mesh; 1" below column surface	90 tons	3 hrs 17 min	-	-	7	2	3 1/4
C-10-SC-4	10"	Column: 10" x 12"; 8" x 6" x 35 lb H beam; protection: Concrete of crushed basalt and sand (4350 psi) 6" x 4" 13 SWG mesh; 1" below column surface	90 tons	3 hrs 22 min	-	-	7	2	3 1/3
C-10-SC-5	10"	Column: 10" x 12"; 8" x 6" x 35 lb H beam; protection: concrete gravel aggregate (5570 psi) 6" x 4" mesh; 13 SWG	90 tons	3 hrs 39 min	-	-	7	2	3 1/2
C-10-SC-6	10"	Column: 10" x 16"; 8" x 6" x 35 lb I beam; protection: gravel concrete (4950 psi) 6" x 4" mesh 13 SWG; 1" below column surface	90 tons	4 hrs 32 min	-	-	7	2	4 1/2
C-10-SC-7	10"	10" x 12" concrete encased steel column; 8" x 6" x 35 lb H beam; protection: aggregate concrete (1370 psi) with 6" x 4" mesh; 13 SWG reinforcing 1" below column surface	90 tons	2 hrs	-	-	7	3,4	2
C-10-SC-8	10"	10" x 12" concrete encased steel column; 8" x 6" x 35 lb H column; protection: aggregate concrete (4000 psi) with 13 SWG iron wire loosely wound around column @ 6" pitch about 2" beneath column surface	86 tons	3 hrs 36 min	-	-	7	2	3 1/2
C-10-SC-9	10"	10" x 12" concrete encased steel column; 8" x 6" x 35 lb H beam; protection: aggregate concrete (3290 psi; 2" cover minimum	86 tons	2 hrs 8 min	-	-	7	2	2
C-10-SC-10	10"	10" x 14" concrete encased steel column; 8" x 6" x 35 lb H column; protection: crushed brick-filled concrete (5310 psi); with 6" x 4" mesh; 13 SWG reinforcement 1" beneath column surface	90 tons	4 hrs 28 min	-	-	7	2	4 1/3
C-10-SC-11	10"	10" x 12" concrete encased column; 8" x 6" x 35 lb H beam; protection: aggregate concrete (3420 psi) with 6" x 4" mesh; 13 SWG reinforcements 1" below surface	90 tons	1 hr 2 min	-	-	7	2	1
C-10-SC-12	10"	10" x 12" concrete encased steel column; 8" x 6" x 35 lb H beam; protection: aggregate concrete (4480 psi) four 3/8" vertical rebars @ H beam edges with 3/16" spacers @ beam surface @ 3' pitch and 3/16" binders @ 10" pitch; 2" concrete cover	90 tons	3 hrs 2 min	-	-	7	2	3

Table 2.5.1.4, continued (Steel Columns—Concrete Encasements, Minimum Dimension 10" to less than 12")

Item Code	Min. Dimen.	Construction Details	Performance		Reference Number			Notes	Rec Hours
			Load	Time	Pre BMS 92	BMS	Post-BMS 92		
C-10-SC-13	10"	10" x 12" concrete encased steel column; 8" x 6" x 35 lb H beam; protection: aggregate concrete (5070 psi) with 6" x 4" mesh; 13 SWG reinforcing @ 6" beam sides wrapped and held by wire ties across (open) 8" beam face; reinforcements wrapped in 6" x 4" mesh; 13 SWG throughout with 1/2" cover to column surface	90 tons	3 hrs 59 min	-	-	7	2	3 3/4
C-10-SC-14	10"	10" x 12" concrete encased steel column; 8" x 6" x 35 lb H column; protection: aggregate concrete (4410 psi) 6" x 4" mesh; 13 SWG reinforcement 1 1/4" below column surface; 1/2" lime-cement plaster with 3/8" gypsum plaster finish	90 tons	2 hrs 50 min	-	-	7	2	2 3/4
C-10-SC-15	10"	10" x 12" concrete encased steel column; 8" x 6" x 35 lb H beam; protection: crushed clay brick-filled concrete (4260 psi) with 6" x 4" mesh; 13 SWG reinforcing 1" below column surface	90 tons	3 hrs 54 min	-	-	7	2	3 3/4
C-10-SC-16	10"	10" x 12" concrete encased steel columns; 8" x 6" x 35 lb H beam; protection: limestone aggregate concrete (4350 psi) 6" x 4" mesh; 13 SWG reinforcing 1" below column surface	90 tons	3 hrs 54 min	-	-	7	2	3 3/4
C-10-SC-17	10"	10" x 12" concrete encased steel column; 8" x 6" x 35 lb H beam; protection: limestone aggregate concrete (5300 psi) with 6" x 4"; 13 SWG wire mesh 1" below column surface	90 tons	3 hrs	-	-	7	4,5	3
C-10-SC-18	10"	10" x 12" concrete encased steel column; 8" x 6" x 35 lb H beam; protection: limestone aggregate concrete (4800 psi) with 6" x 4"; 13 SWG mesh reinforcement 1" below surface	90 tons	3 hrs	-	-	7	4,5	3
C-10-SC-19	10"	10" x 14" concrete encased steel column; 12" x 8" x 65 lb H beam; protection: aggregate concrete (3900 psi) 4" mesh; 16 SWG reinforcing 1/2" below column surface	118 tons	2 hrs 42 min	-	-	7	2	2
C-10-SC-20	10"	10" x 14" concrete encased steel column; 12" x 8" x 65 lb H beam; protection: aggregate concrete (4930 psi); 4" mesh; 16 SWG reinforcing 1/2" below column surface	177 tons	2 hrs 8 min	-	-	7	2	2

Table 2.5.1.4, continued (Steel Columns—Concrete Encasements, Minimum Dimension 10" to less than 12")

Item Code	Min. Dimen.	Construction Details	Performance		Reference Number			Notes	Rec Hours
			Load	Time	Pre BMS 92	BMS	Post-BMS 92		
C-10-SC-21	10 3/8"	10 3/8" x 12 3/8" concrete encased steel column; 8" x 6" x 35 lb H beam; protection: aggregate concrete (835 psi) with 6" x 4" mesh; 13 SWG reinforcing 1 3/16" below column surface; 3/16" gypsum plaster finish	90 tons	2 hrs	-	-	7	3,4	2
C-11-SC-22	11"	11" x 13" concrete encased steel column; 8" x 6" x 35 lb H beam; protection: "open texture" brick-filled concrete (890 psi) with 6" x 4" mesh; 13 SWG reinforcing 1 1/2" below column surface; 3/8" lime cement plaster; 1/8" gypsum plaster finish	90 tons	3 hrs	-	-	7	6,7	3
C-11-SC-23	11"	11" x 12" column; 4" x 3" x 10 lb H beam; gravel concrete (4550 psi); 6" x 4"—13 SWG mesh reinforcing; 1" below column surface	12 tons	6 hrs	-	-	7	7,8	6
C-11-SC-24	11"	11" x 12" column; 4" x 3" 10 lb H beam; protection: gravel aggregate concrete (3830 psi) with 4" x 4" mesh; 16 SWG; 1" below column surface	16 tons	5 hrs 32 min	-	-	7	2	5 1/2
C-10-SC-25	10"	6" x 6" steel column with 4" outside protection; Group I	-	9 hrs	-	1	-	9	9
C-10-SC-26	10"	Description as per C-10-SC-25; Group II	-	7 hrs	-	1	-	9	7
C-10-SC-27	10"	Description as per C-10-SC-25; Group III	-	5 hrs	-	1	-	9	5
C-10-SC-28	10"	Description as per C-10-SC-25; Group IV	-	3 hrs 30 min	-	1	-	9	3 1/2
C-10-SC-29	10"	8" x 8" steel column with 2" outside protection; Group I	-	6 hrs	-	1	-	9	6
C-10-SC-30	10"	Description as per C-10-SC-29; Group II	-	4 hrs	-	1	-	9	4
C-10-SC-31	10"	Description as per C-10-SC-29; Group III	-	3 hrs	-	1	-	9	3
C-10-SC-32	10"	Description as per C-10-SC-29; Group IV	-	2 hrs	-	1	-	9	2
C-11-SC-33	11"	8" x 8" steel column with 3" outside protection; Group I	-	8 hrs	-	1	-	9	8
C-11-SC-34	11"	Description as per C-11-SC-33; Group II	-	6 hrs	-	1	-	9	6
C-11-SC-35	11"	Description as per C-11-SC-33; Group III	-	4 hrs	-	1	-	9	4
C-11-SC-36	11"	Description as per C-11-SC-33; Group IV	-	3 hrs	-	1	-	9	3

Table 2.5.1.4—Notes

Steel Columns—Concrete Encasements, Minimum Dimension 10" to less than 12"

1. Tested under total restraint load to prevent expansion—minimum load 90 tons.
2. Failure mode—collapse.
3. Passed 2-hr fire test (Grade "C"—British).
4. Passed hose stream test.
5. Column tested and passed 3-hr grade fire resistance (British).
6. Column passed 3-hr fire test.
7. Column collapsed during hose stream testing.
8. Column passed 6-hr fire test.
9. Group I—includes concrete having calcareous aggregate containing a combined total of not more than 10 percent of quartz, chert, and flint for the coarse aggregate.

Group II—includes concrete having trap-rock aggregate applied without metal ties and also concrete having cinder, sandstone, or granite aggregate, if held in place with wire mesh or expanded metal having not larger than 4-in. mesh, weighing not less than 1.7 lb/yd², placed not more than 1 in. from the surface of the concrete.

Group III—includes concrete having cinder, sandstone, or granite aggregate tied with No. 5 gauge steel wire, wound spirally over the column section on a pitch of 8 in., or equivalent ties, and concrete having siliceous aggregates containing a combined total of 60 percent or more of quartz, chert, and flint, if held in place with wire mesh or expanded metal having not larger than 4-in. mesh, weighing not less than 1.7 lb/yd², placed not more than 1 in. from the surface of the concrete.

Group IV—includes concrete having siliceous aggregate containing a combined total of 60 percent or more of quartz, chert, and flint, and tied with No. 5 gauge steel wire wound spirally over the column section on a pitch of 8 in., or equivalent ties.

Figure 2.5.1.5
Steel Columns—Concrete Encasements
Minimum Dimension 12" to less than 14"

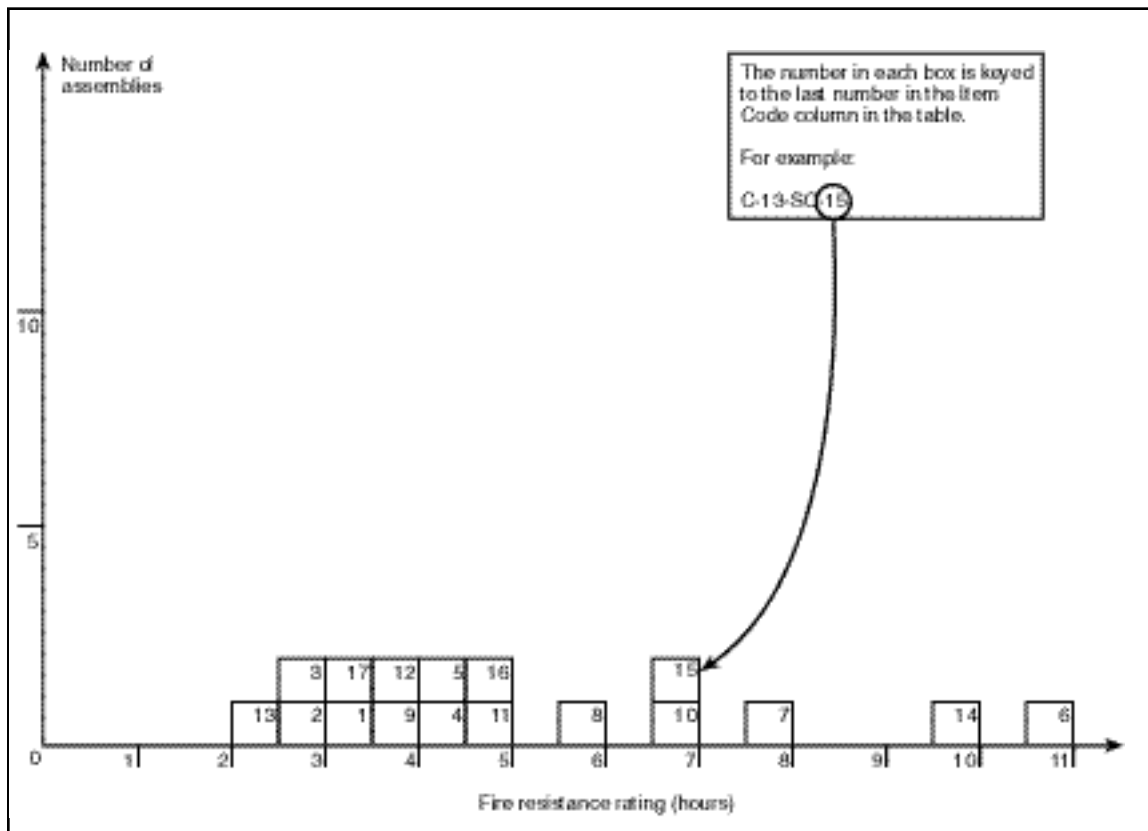

Table 2.5.1.5
Steel Columns—Concrete Encasements
Minimum Dimension 12" (300 mm) to less than 14" (350 mm)

Item Code	Min. Dimen.	Construction Details	Performance		Reference Number			Notes	Rec Hours
			Load	Time	Pre BMS 92	BMS	Post-BMS 92		
C-12-SC-1	12"	12" x 14" concrete encased steel column; 8" x 6" x 35 lb H beam; protection: aggregate concrete (4150 psi) with 4" mesh; 16 SWG reinforcing 1" below column surface	120 tons	3 hrs 24 min	-	-	7	1	3 1/3
C-12-SC-2	12"	12" x 16" concrete encased column; 8" x 6" x 35 lb H beam; protection: aggregate concrete (4300 psi) with 4" mesh; 16 SWG reinforcing 1" below surface	90 tons	24 hrs 52 min	-	-	7	1	2 3/4
C-12-SC-3	12"	12" x 16" concrete encased steel column; 12" x 8" x 65 lb H column; protection: gravel aggregate concrete (3550 psi) with 4" mesh; 16 SWG reinforcement 1" below column surface	177 tons	2 hrs 31 min	-	-	7	1	2 1/2
C-12-SC-4	12"	12" x 16" concrete encased column; 12" x 8" x 65 lb H beam; protection: aggregate concrete (3450 psi) with 4"—16 SWG mesh reinforcement 1" below column surface	118 tons	4 hrs 4 min	-	-	7	1	4
C-12-SC-5	12 1/2"	12 1/2" x 14" column; 6" x 4 1/2" x 20 lb H beam; protection: gravel aggregate concrete (3750 psi) with 4" x 4" mesh; 16 SWG reinforcing 1" below column surface	52 tons	4 hrs 29 min	-	-	7	1	4 1/3
C-12-SC-6	12"	8" x 8" steel column; 2" outside protection; Group I	-	11 hrs	-	-	1	2	11
C-12-SC-7	12"	Description as per C-12-SC-6; Group II	-	8 hrs	-	1	-	2	8
C-12-SC-8	12"	Description as per C-12-SC-6; Group III	-	6 hrs	-	1	-	2	6
C-12-SC-9	12"	Description as per C-12-SC-6; Group IV	-	4 hrs	-	1	-	2	4
C-12-SC-10	12"	10" x 10" steel column with 2" outside protection; Group I	-	7 hrs	-	1	-	2	7
C-12-SC-11	12"	Description as per C-12-SC-10; Group II	-	5 hrs	-	1	-	2	5
C-12-SC-12	12"	Description as per C-12-SC-10; Group III	-	4 hrs	-	1	-	2	4
C-12-SC-13	12"	Description as per C-12-SC-10; Group IV	-	2 hrs 30 min	-	1	-	2	2 1/2
C-13-SC-14	13"	10" x 10" steel column with 3" outside protection; Group I	-	10 hrs	-	1	-	2	10

Table 2.5.1.5, continued (Steel Columns—Concrete Encasements, Minimum Dimension 12" to less than 14")

Item Code	Min. Dimen.	Construction Details	Performance		Reference Number			Notes	Rec Hours
			Load	Time	Pre BMS 92	BMS	Post-BMS 92		
C-13-SC-15	13"	Description as per C-13-SC-14; Group II	-	7 hrs	-	1	-	2	7
C-13-SC-16	13"	Description as per C-13-SC-14; Group III	-	5 hrs	-	1	-	2	5
C-13-SC-17	13"	Description as per C-13-SC-14; Group IV	-	3 hrs 30 min	-	1	-	2	3 1/2

Table 2.5.1.5—Notes**Steel Columns—Concrete Encasements
Minimum Dimension 12" to less than 14"**

1. Failure mode—collapse.
2. Group I—includes concrete having calcareous aggregate containing a combined total of not more than 10 percent of quartz, chert, and flint for the coarse aggregate.

Group II—includes concrete having trap-rock aggregate applied without metal ties and also concrete having cinder, sandstone, or granite aggregate, if held in place with wire mesh or expanded metal having not larger than 4-in. mesh, weighing not less than 1.7 lb/yd², placed not more than 1 in. from the surface of the concrete.

Group III—includes concrete having cinder, sandstone, or granite aggregate tied with No. 5 gauge steel wire, wound spirally over the column section on a pitch of 8 in., or equivalent ties, and concrete having siliceous aggregates containing a combined total of 60 percent or more of quartz, chert, and flint, if held in place with wire mesh or expanded metal having not larger than 4-in. mesh, weighing not less than 1.7 lb/yd², placed not more than 1 in. from the surface of the concrete.

Group IV—includes concrete having siliceous aggregate containing a combined total of 60 percent or more of quartz, chert, and flint, and tied with No. 5 gauge steel wire wound spirally over the column section on a pitch of 8 in., or equivalent ties.

Figure 2.5.1.6
Steel Columns—Concrete Encasements
Minimum Dimension 14" to less than 16"

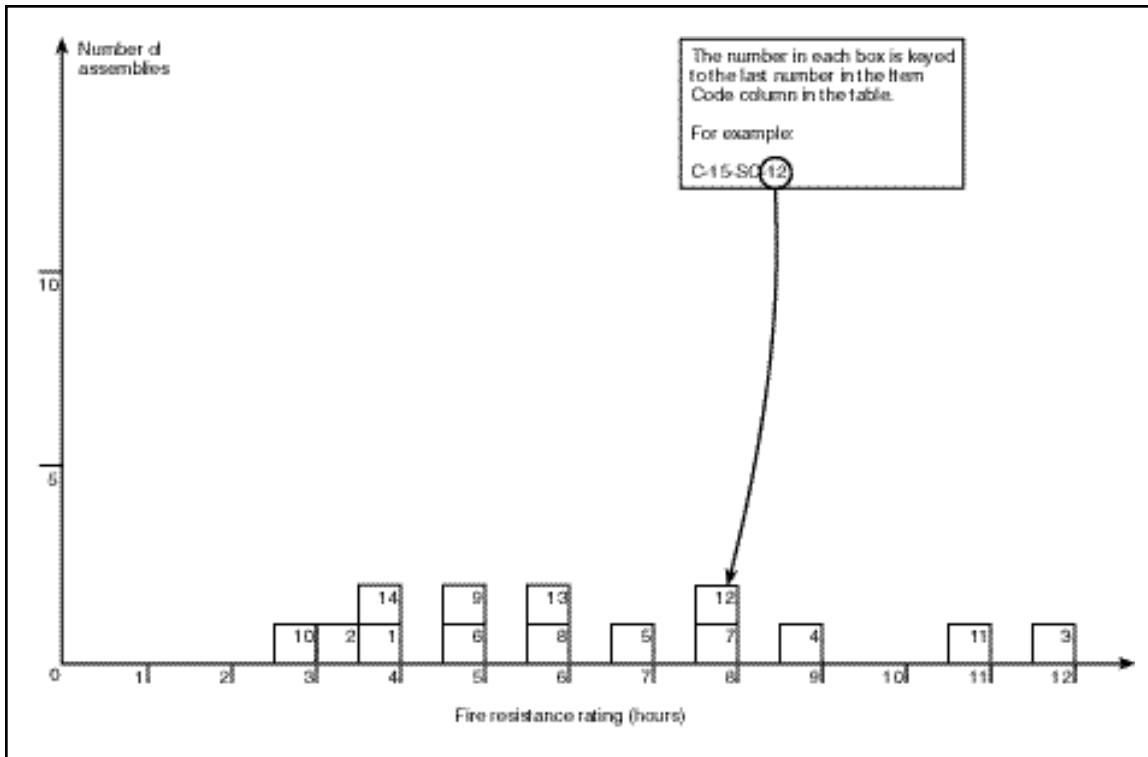

Table 2.5.1.6
Steel Columns—Concrete Encasements
Minimum Dimension 14" (250 mm) to less than 16" (400 mm)

Item Code	Min. Dimen.	Construction Details	Performance		Reference Number			Notes	Rec Hours
			Load	Time	Pre BMS 92	BMS	Post-BMS 92		
C-14-SC-1	14"	14" x 6" concrete encased steel column; 8" x 6" x 35 lb H column; protection: aggregate concrete (4240 psi) with 4" mesh 16 SWG reinforcing 1" below column surface	90 tons	3 hrs 40 min	-	-	7	1	3
C-14-SC-2	14"	14" x 18" concrete encased steel column; 12" x 8" x 65 lb H beam; protection: gravel aggregate concrete (4000 psi) with 4" 16 SWG wire mesh reinforcement 1" below column surface	177 tons	3 hrs 20 min	-	-	7	1	3
C-14-SC-3	14"	10" x 10" steel column with 4" outside protection; Group I	-	12 hrs	-	1	-	2	12

Table 2.5.1.6, continued (Steel Columns—Concrete Encasements, Minimum Dimension 14" to less than 16")

Item Code	Min. Dimen.	Construction Details	Performance		Reference Number			Notes	Rec Hours
			Load	Time	Pre BMS 92	BMS	Post-BMS 92		
C-14-SC-4	14"	Description as per C-14-SC-3; Group II	-	9 hrs	-	1	-	2	9
C-14-SC-5	14"	Description as per C-14-SC-3; Group III	-	7 hrs	-	1	-	2	7
C-14-SC-6	14"	Description as per C-14-SC-3; Group IV	-	5 hrs	-	1	-	2	5
C-14-SC-7	14"	12" x 12" steel column with 2" outside protection; Group I	-	8 hrs	-	1	-	2	8
C-14-SC-8	14"	Description as per C-14-SC-7; Group II	-	6 hrs	-	1	-	2	6
C-14-SC-9	14"	Description as per C-14-SC-7; Group III	-	5 hrs	-	1	-	2	5
C-14-SC-10	14"	Description as per C-14-SC-7; Group IV	-	3 hrs	-	1	-	2	3
C-15-SC-11	15"	12" x 12" steel column with 3" outside protection; Group I	-	11 hrs	-	1	-	2	11
C-15-SC-12	15"	Description as per C-15-SC-11; Group II	-	8 hrs	-	1	-	2	8
C-15-SC-13	15"	Description as per C-15-SC-11; Group III	-	6 hrs	-	1	-	2	6
C-15-SC-14	15"	Description as per C-15-SC-11; Group IV	-	4 hrs	-	1	-	2	4

Table 2.5.1.6—Notes**Steel Columns—Concrete Encasements
Minimum Dimension 14" to less than 16"**

1. Collapse.
2. Group I—includes concrete having calcareous aggregate containing a combined total of not more than 10 percent of quartz, chert, and flint for the coarse aggregate.

Group II—includes concrete having trap-rock aggregate applied without metal ties and also concrete having cinder, sandstone, or granite aggregate, if held in place with wire mesh or expanded metal having not larger than 4-in. mesh, weighing not less than 1.7 lb/yd², placed not more than 1 in. from the surface of the concrete.

Group III—includes concrete having cinder, sandstone, or granite aggregate tied with No. 5 gauge steel wire, wound spirally over the column section on a pitch of 8 in., or equivalent ties, and concrete having siliceous aggregates containing a combined total of 60 percent or more of quartz, chert, and flint, if held in place with wire mesh or expanded metal having not larger than 4-in. mesh, weighing not less than 1.7 lb/yd², placed not more than 1 in. from the surface of the concrete.

Group IV—includes concrete having siliceous aggregate containing a combined total of 60 percent or more of quartz, chert, and flint, and tied with No. 5 gauge steel wire wound spirally over the column section on a pitch of 8 in., or equivalent ties.

Table 2.5.1.7
Steel Columns—Concrete Encasements
Minimum Dimension 16" (400 mm) to less than 18" (450 mm)

Item Code	Min. Dimen.	Construction Details	Performance		Reference Number			Notes	Rec Hours
			Load	Time	Pre BMS 92	BMS	Post-BMS 92		
C-16-SC-1	16"	12"x 12" steel column with 4" outside protection; Group I	-	14 hrs	-	1	-	1	14
C-16-SC-2	16"	Description as per C-16-SC-1; Group II	-	10 hrs	-	1	-	1	10
C-16-SC-3	16"	Description as per C-16-SC-1; Group III	-	8 hrs	-	1	-	1	8
C-16-SC-4	16"	Description as per C-16-SC-1; Group IV	-	5 hrs	-	1	-	1	5

Table 2.5.1.7—Notes

Steel Columns—Concrete Encasements

Minimum Dimension 16" to less than 18"

1. Group I—includes concrete having calcareous aggregate containing a combined total of not more than 10 percent of quartz, chert, and flint for the coarse aggregate.

Group II—includes concrete having trap-rock aggregate applied without metal ties and also concrete having cinder, sandstone, or granite aggregate, if held in place with wire mesh or expanded metal having not larger than 4-in. mesh, weighing not less than 1.7 lb/yd², placed not more than 1 in. from the surface of the concrete.

Group III—includes concrete having cinder, sandstone, or granite aggregate tied with No. 5 gauge steel wire, wound spirally over the column section on a pitch of 8 in., or equivalent ties, and concrete having siliceous aggregates containing a combined total of 60 percent or more of quartz, chert, and flint, if held in place with wire mesh or expanded metal having not larger than 4-in. mesh, weighing not less than 1.7 lb/yd², placed not more than 1 in. from the surface of the concrete.

Group IV—includes concrete having siliceous aggregate containing a combined total of 60 percent or more of quartz, chert, and flint, and tied with No. 5 gauge steel wire wound spirally over the column section on a pitch of 8 in., or equivalent ties.

Table 2.5.2.1
Steel Columns—Brick and Block Encasements
Minimum Dimension 10" (250 mm) to less than 12" (300 mm)

Item Code	Min. Dimen.	Construction Details	Performance		Reference Number			Notes	Rec Hours
			Load	Time	Pre BMS 92	BMS	Post-BMS 92		
C-10-SB-1	10 1/2"	10 1/2"x 13" brick-encased steel columns; 8" x 6" x 35 lb H beam; protection: fill of broken brick and mortar; 2" brick on edge, joints broken in alt. courses; cement-sand grout; 13 SWG wire reinforcement in every third horizontal joint	90 tons	3 hrs 6 min	-	-	7	1	3
C-10-SB-2	10 1/2"	10 1/2"x 13" brick-encased steel columns; 8" x 6" x 35 lb H beam; protection: 2" brick, joints broken in alt. courses; cement-sand grout; 13 SWG iron wire reinforcement in alternate horizontal joints	90 tons	2 hrs	-	-	7	2-4	2
C-10-SB-3	10"	10" x 12" block-encased columns; 8" x 6" x 35 lb H beam; protection: 2" foamed slag concrete blocks; 13 SWG wire at each horizontal joint; mortar at each joint	90 tons	2 hrs	-	-	7	5	2
C-10-SB-4	10 1/2"	10 1/2" x 12" block-encased steel columns; 8" x 6" x 35 lb H beam; protection: gravel aggregate concrete fill (unconsolidated); 2" thick hollow clay tiles with mortar at edges	86 tons	56 min	-	-	7	1	3/4
C-10-SB-5	10 1/2"	10 1/2" x 12" block-encased steel columns; 8" x 6" x 35 lb. H beam; protection: 2" hollow clay tiles with mortar at edges	86 tons	22 min	-	-	7	1	1/4

Table 2.5.2.1—Notes

Steel Columns—Brick and Block Encasements
Minimum Dimension 10" to less than 12"

1. Failure mode—collapse.
2. Passed 2-hr fire test (Grade "C"—British).
3. Passed hose stream test.
4. Passed reload test.
5. Passed 2-hr fire exposure but collapsed immediately following hose stream test.

Table 2.5.2.2
Steel Columns—Brick and Block Encasements
Minimum Dimension 12" (300 mm) to less than 14" (350 mm)

Item Code	Min. Dimen.	Construction Details	Performance		Reference Number			Notes	Rec Hours
			Load	Time	Pre BMS 92	BMS	Post-BMS 92		
C-12-SB-1	12"	12" x 15" brick-encased steel columns; 8" x 6" x 35 lb H beam; protection: 2 5/8" thick brick; joints broken in alt. courses; cement-sand grout; fill of broken brick and mortar	90 tons	1 hr 49 min	-	-	7	1	1 3/4

Table 2.5.2.2—Notes

Steel Columns—Brick and Block Encasements, Minimum Dimension 12" to less than 14"

1. Failure mode—collapse.

Table 2.5.2.3
Steel Columns—Brick and Block Encasements
Minimum Dimension 14" (350 mm) to less than 16" (400 mm)

Item Code	Min. Dimen.	Construction Details	Performance		Reference Number			Notes	Rec Hours
			Load	Time	Pre BMS 92	BMS	Post-BMS 92		
C-15-SB-1	15"	15" x 17" brick-encased steel columns; 8" x 6" x 35 lb H beam; protection: 4 1/2" brick; joints broken in alt. courses; cement-sand grout; fill of broken brick and mortar	45 tons	6 hrs	-	-	7	1	6
C-15-SB-2	15"	15" x 17" brick-encased steel columns; 8" x 6" x 35 lb H beam; protection: fill of broken brick and mortar; 4 1/2" brick, joints broken in alt. courses; cement-sand grout	86 tons	6 hrs	-	-	7	2-4	6
C-15-SB-3	15"	15" x 18" brick-encased steel columns; 8" x 6" x 35 lb H beam; protection: 4 1/2" brick ; joints alternating; cement-sand grout	90 tons	4 hrs	-	-	7	5,6	4
C-15-SB-4	14"	14" x 16" block-encased steel columns; 8" x 6" x 35 lb H beam; protection: 4" thick foam slag concrete blocks; 13 SWG wire reinforcement in each horizontal joint; mortar in joints	90 tons	5 hrs 52 min	-	-	7	7	4 3/4

Table 2.5.2.3—Notes

Steel Columns—Brick and Block Encasements Minimum Dimension 14" to less than 16"

1. Only a nominal load was applied to specimen.
2. Passed 6-hr fire test (Grade "A"—British).
3. Passed (6 min.) hose stream test.
4. Reload not specified.
5. Passed 4-hr fire exposure.
6. Failed by collapse between 1st and 2nd minute of hose stream exposure.
7. Mode of failure—collapse.

Table 2.5.3.1
Steel Columns—Plaster Encasements
Minimum Dimension 6" (150 mm) to less than 8" (200 mm)

Item Code	Min. Dimen.	Construction Details	Performance		Reference Number			Notes	Rec Hours
			Load	Time	Pre BMS 92	BMS	Post-BMS 92		
C-7-SP-1	7 1/2"	7 1/2" x 9 1/2" plaster protected steel columns; 8" x 6" x 35 lb H beam; protection: 24 SWG wire metal lath; 1 1/4" lime plaster	90 tons	57 min	-	-	7	1	3/4
C-7-SP-2	7 7/8"	7 7/8" x 10" plaster protected steel columns; 8" x 6" x 35 lb H beam; protection: 3/8" gypsum bal. wire wound with 16 SWG wire helically wound @ 4" pitch; 1/2" gypsum plaster	90 tons	1 hr 13 min	-	-	7	1	1
C-7-SP-3	7 1/4"	7 1/4" x 9 3/8" plaster protected steel columns; 8" x 6" x 35 lb H beam; protection: 3/8" gypsum board; wire helically wound 16 SWG @ 4" pitch; 1/4" gypsum plaster finish	90 tons	1 hr 14 min	-	-	7	1	1

Table 2.5.3.1—Notes

Steel Columns—Plaster Encasements
Minimum Dimension, 6" to less than 8"

1. Failure mode—collapse.

Table 2.5.3.2
Steel Columns—Plaster Encasements
Minimum Dimension 8" (200 mm) to less than 10" (250 mm)

Item Code	Min. Dimen.	Construction Details	Performance		Reference Number			Notes	Rec Hours
			Load	Time	Pre BMS 92	BMS	Post-BMS 92		
C-8-SP-1	8"	8" x 10" plaster protected steel columns; 8" x 6" x 35 lb H beam; protection: 24 SWG wire lath with 1" gypsum plaster	86 tons	1 hr 23 min	-	-	7	1	1 1/4
C-8-SP-2	8 1/2"	8 1/2 x 10 1/2" plaster protected steel columns; 8" x 6" x 35 lb H beam; protection: 24 SWG metal lath wrap; 1 1/4" gypsum plaster	90 tons	1 hr 36 min	-	-	7	1	1 1/2
C-9-SP-3	9"	9" x 11" plaster protected steel columns; 8" x 6" x 35 lb H beam; protection: 24 SWG metal lath wrap; 1/8" M. S. ties at 12" pitch wire netting 1 1/2" x 22 SWG between 1st and 2nd plaster coats; 1 1/2" gypsum plaster	90 tons	1 hr 33 min	-	-	7	1	1 1/2
C-8-SP-4	8 3/4"	8 3/4" x 10 3/4" plaster protected steel columns 8" x 6" x 35 lb H beam; protection: 3/4" gypsum board—wire wound spirally (#16 SWG) @ 1 1/2" pitch; 1/2" gypsum plaster	90 tons	2 hrs	-	-	7	2-4	2

Table 2.5.3.2—Notes**Steel Columns - Plaster Encasements**
Minimum Dimension, 8" to less than 10"

1. Failure mode—collapse.
2. Passed 2-hr fire exposure test (Grade "C"—British).
3. Passed hose stream test.
4. Passed reload test.

Table 2.5.4.1
Steel Columns—Miscellaneous Encasements
Minimum Dimension 6" (150 mm) to less than 8" (200 mm)

Item Code	Min. Dimen.	Construction Details	Performance		Reference Number			Notes	Rec Hours
			Load	Time	Pre BMS 92	BMS	Post-BMS 92		
C-7-SM-1	7 5/8"	7 5/8" x 9 1/2" (asbestos plaster) protected steel columns; 8" x 6" x 35 lb H beam; protection: 20 ga. 1/2" metal lath; 9/16" asbestos plaster (min.)	90 tons	1 hr 52 min	-	-	7	1	1 3/4

Table 2.5.4.1—Notes
Steel Columns—Miscellaneous Encasements
Minimum Dimension 6" to less than 8"

1. Failure mode—collapse.

Table 2.5.4.2
Steel Columns—Miscellaneous Encasements
Minimum Dimension 8" (200 mm) to less than 10" (250 mm)

Item Code	Min. Dimen.	Construction Details	Performance		Reference Number			Notes	Rec Hours
			Load	Time	Pre BMS 92	BMS	Post-BMS 92		
C-9-SM-1	9 5/8"	9 5/8" x 11 3/8" asbestos slab and cement plaster protected columns; 8" x 6" x 35 lb H beam; protection: 1" asbestos slabs, wire wound, 5/8" plaster	90 tons	2 hrs	-	-	7	1,2	2

Table 2.5.4.2—Notes
Steel Columns—Miscellaneous Encasement
Minimum Dimension 8" to less than 10"

1. Passed 2-hr fire exposure test.
2. Collapsed during hose stream test.

Table 2.5.4.3
Steel Columns—Miscellaneous Encasements
Minimum Dimension 10" (250 mm) to less than 12" (300 mm)

Item Code	Min. Dimen.	Construction Details	Performance		Reference Number			Notes	Rec Hours
			Load	Time	Pre BMS 92	BMS	Post-BMS 92		
C-11-SM-1	11 1/2"	11 1/2" x 13 1/2" wood, wool and plaster protected steel columns; 8" x 6" x 35 lb H beam; protection: wood-wool-cement paste as fill and to 2" cover over beam; 3/4" gypsum plaster finish	90 tons	2 hrs	-	-	7	1-3	2
C-10-SM-2	10"	10" x 12" asbestos protected steel columns; 8" x 6" x 35 lb H beam; protection: sprayed on asbestos paste to 2" cover over column	90 tons	4 hrs	-	-	7	2-4	4

Table 2.5.4.3—Notes

Steel Columns—Miscellaneous Encasements
Minimum Dimension 10" to less than 12"

1. Passed 2-hr fire exposure test (Grade "C"—British).
2. Passed hose stream test.
3. Passed reload test.
4. Passed 4-hr fire exposure test.

Table 2.5.4.4
Steel Columns—Miscellaneous Encasements
Minimum Dimension 12" (300 mm) to less than 14" (350 mm)

Item Code	Min. Dimen.	Construction Details	Performance		Reference Number			Notes	Rec Hours
			Load	Time	Pre BMS 92	BMS	Post-BMS 92		
C-12-SM-1	12"	12" X 14 1/4" cement and asbestos protected column; 8" x 6" x 35 lb H beam; protection: fill of asbestos packing pieces 1" thick 1' 3" O.C.; cover of 2" molded asbestos inner layer; 1" molded asbestos outer layer; held in position by 16 SWG nichrome wire ties; wash of refractory cement on outer surface	86 tons	4 hrs 43 min	-	-	7	1-3	4 2/3

Table 2.5.4.4—Notes

Steel Columns—Miscellaneous Encasements
Minimum Dimension 12" to less than 14"

1. Passed 4-hr fire exposure (Grade "B"—British).
2. Passed hose stream test.
3. Passed reload test.

Section III—Floor/Ceiling Assemblies

Figure 3.1
Floor/Ceiling Assemblies—Reinforced Concrete

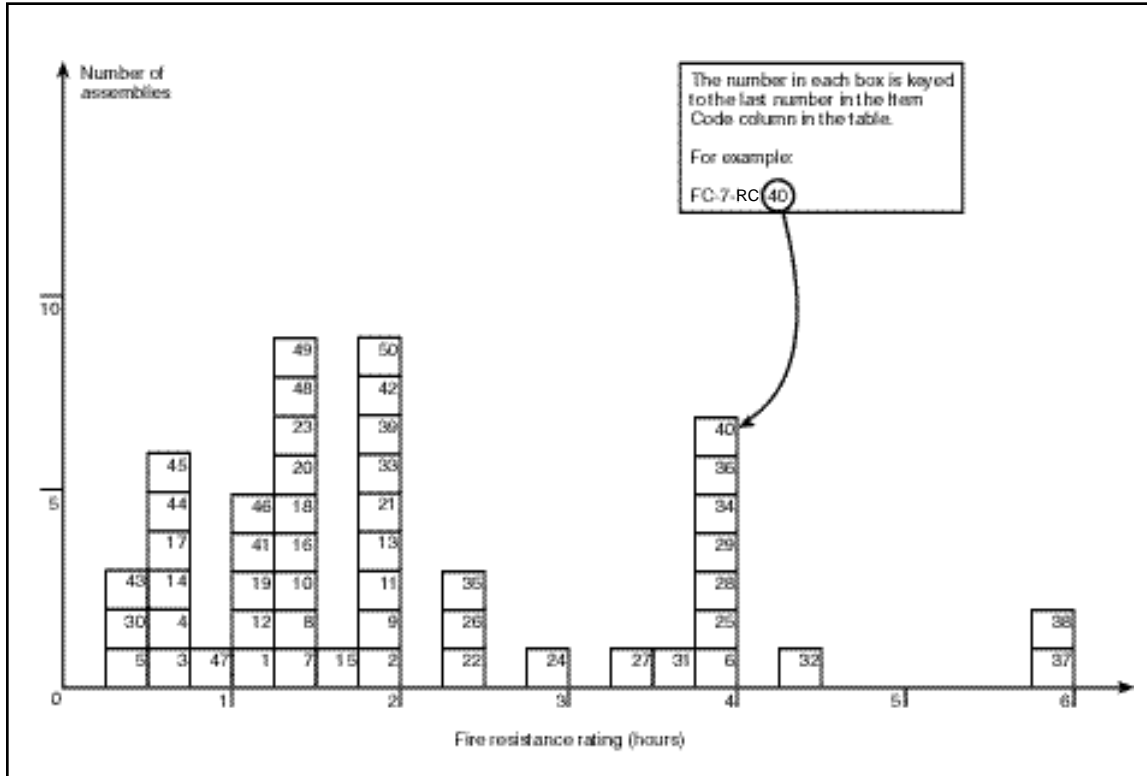

Table 3.1
Floor/Ceiling Assemblies—Reinforced Concrete

Item code	Assembly Thickness	Construction Details	Performance		Reference Number			Notes	Rec Hours
			Load	Time	Pre BMS 92	BMS	Post-BMS 92		
FC-3-RC-1	3 3/4"	3 3/4" thick floor; 3 1/4" (5475 psi) concrete deck; 1/2" plaster under deck; 3/8" main rein. bars @ 5 1/2" pitch with 7/8" concrete cover; 3/8" main rein. bars @ 4 1/2" pitch perpendicular with 1/2" concrete cover; 13'1" span restrained	195 psf	24 min	-	-	7	1,2	1
FC-3-RC-2	3 1/4"	3 1/4" deep (3540 psi) concrete deck; 3/8" main rein. bars @ 5 1/2" pitch with 7/8" cover; 3/8" main rein. bars @ 4 1/2" pitch perpendicular with 1/2" cover; 13'1" span restrained	195 psf	2 hrs	-	-	7	1,3,4	1 3/4

Table 3.1, continued (Floor/Ceiling Assemblies—Reinforced Concrete)

Item code	Assem- bly Thick- ness	Construction Details	Performance		Reference Number			Notes	Rec Hours
			Load	Time	Pre BMS 92	BMS	Post- BMS 92		
FC-3-RC-3	3 1/4"	3 1/4" deep (4175 psi) concrete deck; 3/8" main rein. bars @ 5 1/2" pitch with 7/8" cover; 3/8" main rein. bars @ 4 1/2" pitch perpendicular with 1/2" cover; 13'1" span restrained	195 psf	31 min	-	-	7	1,5	1/2
FC-3-RC-4	3 1/4"	3 1/4" deep (4355 psi) concrete deck; 3/8" main rein. bars @ 5 1/2" pitch with 7/8" cover; 3/8" main rein. bars @ 4 1/2" pitch perpendicular with 1/2" cover; 13'1" span restrained	195 psf	41 min	-	-	7	1,5,6	1/2
FC-3-RC-5	3 1/4"	3 1/4" thick (3800 psi) concrete deck; 3/8" main rein. bars @ 5 1/2" pitch with 7/8" cover; 3/8" main rein. bars @ 4 1/2" pitch perpendicular with 1/2" cover; 13'1" span restrained	195 psf	1 hr 5 min	-	-	7	1,5	1/4
FC-4-RC-6	4 1/4"	4 1/4" thick; 3 1/4" concrete deck (4000 psi); 1" sprayed asbestos lower surface; 3/8" main rein. bars @ 5 7/8" pitch with 7/8" concrete cover; 3/8" main rein. bars @ 4 1/2" pitch perpendicular with 1/2" concrete cover; 13'1" span restrained	195 psf	4 hrs	-	-	7	1,7	4
FC-4-RC-7	4"	4" deck (5025 psi); 1/4" rein. bars @ 7 1/2" pitch with 3/4" cover; 3/8" main rein. bars @ 3 3/4" pitch perpendicular with 1/2" cover; 13'1" span restrained	140 psf	1 hr 16 min	-	-	7	1,2	1 1/4
FC-4-RC-8	4"	4" thick (4905 psi) deck; 1/4" rein. bars @ 7 1/2" pitch with 7/8" cover; 3/8" main rein. bars @ 3 3/4" pitch perpendicular with 1/2" cover; 13'1" span restrained	100 psf	1 hr 23 min	-	-	7	1,2	1 1/3
FC-4-RC-9	4"	4" deep (4370 psi); 1/4" rein. bars @ 6" pitch with 3/4" cover; 1/4" main rein. bars @ 4" pitch perpendicular with 1/2" cover; 13'1" span restrained	150 psf	2 hr	-	-	7	1,3	2
FC-4-RC-10	4"	4" thick (5140 psi) deck; 1/4" rein. bars @ 7 1/2" pitch with 7/8" cover; 3/8" main rein. bars @ 3 3/4" pitch perpendicular with 1/2" cover; 13'1" span restrained	140 psf	1 hr 16 min	-	-	7	1,5	1 1/4
FC-4-RC-11	4"	4" thick (4000 psi) concrete deck; 3" x 1 1/2" x 4 lb R.S.J.; 2'6" C.R.S.; flush with top surface; 4" x 6" x 13 S.W.G. mesh rein. 1" from bottom of slab; 6'6" span restrained	150 psf	2 hrs	-	-	7	1,3	2
FC-4-RC-12	4"	4" deep (2380 psi) concrete deck; 3" x 1 1/2" x 4 lb R.S.J.; 2'6" C.R.S.; flush with top surface; 4" x 6" x 13 S.W.G. mesh rein. 1" from bottom surface; 6'6" span restrained	150 psf	1 hr 3 min	-	-	7	1,2	1

Table 3.1, continued (Floor/Ceiling Assemblies—Reinforced Concrete)

Item code	Assem- bly Thick- ness	Construction Details	Performance		Reference Number			Notes	Rec Hours
			Load	Time	Pre BMS 92	BMS	Post- BMS 92		
FC-4-RC-13	4 1/2"	4 1/2" thick (5200 psi) deck; 1/4" rein. bars @ 7 1/4" pitch with 7/8" cover; 3/8" main rein. bars @ 3 3/4" pitch perpendicular with 1/2" cover; 13'1" span restrained	140 psf	2 hrs	-	-	7	1,3	2
FC-4-RC-14	4 1/2"	4 1/2" deep (2525 psi) concrete deck; 1/4" rein. bars @ 7 1/2" pitch with 7/8" cover; 3/8" main rein. bars @ 3 3/8" pitch perpendicular with 1/2" cover; 13'1" span restrained	150 psf	42 min	-	-	7	1,5	2/3
FC-4-RC-15	4 1/2"	4 1/2" deep (4830 psi) concrete deck; 1 1/2" x No. 15 gauge wire mesh; 3/8" rein. bar @ 15" pitch with 1" cover; 1/2" main rein. bars @ 6" pitch perpendicular with 1/2" cover; 12' span simply supported	75 psf	1 hr 32 min	-	-	7	1,8	1 1/2
FC-4-RC-16	4 1/2"	4 1/2" deep (4595 psi) concrete deck; 1/4" rein. bars @ 7 1/2" pitch with 7/8" cover; 3/8" main rein. bars @ 3 1/2" pitch perpendicular with 1/2" cover; 12' span simply supported	75 psf	1 hr 20 min	-	-	7	1,8	1 1/3
FC-4-RC-17	4 1/2"	4 1/2" deep (3625 psi) concrete deck; 1/4" rein. bars @ 7 1/2" pitch with 7/8" cover; 3/8" main rein. bars @ 3 1/2" pitch perpendicular with 1/2" cover; 12' span simply supported	75 psf	35 min	-	-	7	1,8	1/2
FC-4-RC-18	4 1/2"	4 1/2" deep (4410 psi) concrete deck; 1/4" rein. bars @ 7 1/2" pitch with 7/8" cover; 3/8" main rein. bars @ 3 1/2" pitch perpendicular with 1/2" cover; 12' span simply supported	85 psf	1 hr 27 min	-	-	7	1,8	1 1/3
FC-4-RC-19	4 1/2"	4 1/2" deep (4850 psi) deck; 3/8" rein. bars @ 15" pitch with 1" cover; 1/2" main rein. bars @ 6" pitch perpendicular with 1/2" cover; 12' span simply supported	75 psf	2 hrs 15 min	-	-	7	1,9	1 1/4
FC-4-RC-20	4 1/2"	4 1/2" deep (3610 psi) deck; 1/4" rein. bars @ 7 1/2" pitch with 7/8" cover; 3/8" main rein. bars @ 3 1/2" pitch perpendicular with 1/2" cover; 12' span simply supported	75 psf	1 hr 22 min	-	-	7	1,8	1 1/3
FC-5-RC-21	5"	5" deep (5830 psi) concrete deck; 1/2" plaster finish bottom of slab; 1/4" rein. bars 7 1/2" pitch with 7/8" cover; 3/8" main rein. bars @ 3 1/2" pitch perpendicular with 1/2" cover; 12' span simply supported	69 psf	2 hrs	-	-	7	1,3	2
FC-5-RC-22	5"	4 1/2" (5290 psi) concrete deck; 1/2" plaster finish bottom of slab; 1/4" rein. bars @ 7 1/2" pitch with 7/8" cover; 3/8" main rein. bars @ 3 1/2" pitch perpendicular with 1/2" cover; 12' span simply supported	No load	2 hrs 28 min	-	-	7	1,10,11	2 1/4

Table 3.1, continued (Floor/Ceiling Assemblies—Reinforced Concrete)

Item code	Assembly Thickness	Construction Details	Performance		Reference Number			Notes	Rec Hours
			Load	Time	Pre BMS 92	BMS	Post-BMS 92		
FC-5-RC-23	5"	5" deep (3020 psi) concrete deck; 3" x 1 1/2" x 4 lb R.S.J.; 2" C.R.S. with 1" cover on bottom and top flanges; 8' span restrained	172 psf	1 hr 24 min	-	-	7	1,2,12	1 1/2
FC-5-RC-24	5 1/2"	5" (5180 psi) concrete deck; 1/2" retarded plaster underneath slab; 1/4" rein. bars @ 7 1/2" pitch with 1 3/8" cover; 3/8" main rein. bars @ 3 1/2" pitch perpendicular with 1" cover; 12' span simply supported	60 psf	2 hrs 48 min	-	-	7	1,10	2 3/4
FC-6-RC-25	6"	6" deep (4800 psi) concrete deck; 1/4" rein. bars @ 7 1/2" pitch with 7/8" cover; 3/8" main rein. bars @ 3 1/2" pitch perpendicular with 7/8" cover; 13'1" span restrained.	195 psf	4 hrs	-	-	7	1,7	4
FC-6-RC-26	6"	6" (4650 psi) concrete deck; 1/4" rein. bars @ 7 1/2" pitch with 7/8" cover; 3/8" main rein. bars @ 3 1/2" pitch perpendicular with 1/2" cover; 13'1" span restrained	195 psf	2 hrs 23 min	-	-	7	1,2	2 1/4
FC-6-RC-27	6"	6" deep (6050 psi) concrete deck; 1/4" rein. bars @ 7 1/2" pitch with 7/8" cover; 3/8" main rein. bars @ 3 1/2" pitch perpendicular with 1/2" cover; 13'1" span restrained	195 psf	3 hr 30 min	-	-	7	1,10	3 1/2
FC-6-RC-28	6"	6" deep (5180 psi) concrete deck; 1/4" bars @ 8" pitch with 3/4" cover; 1/4" bars @ 5 1/2" pitch with 1/2" cover perpendicular; 13'1" span restrained	150 psf	4 hrs	-	-	7	1,7	4
FC-6-RC-29	6"	6" thick (4180 psi) concrete deck; 4" x 3" x 10 lb R.S.J.; 2'6" C.R.S. with 1" cover on both bottom and top flanges; 13'1" span restrained	160 psf	3 hr 48 min	-	-	7	1,10	3 3/4
FC-6-RC-30	6"	6" thick (3720 psi) concrete deck; 4" x 3" x 10 lb R.S.J.; 2'6" C.R.S. with 1" cover on both top and bottom flanges; 12' span simply supported	115 psf	29 min	-	-	7	1,5,13	1/4
FC-6-RC-31	6"	6" deep (3450 psi) concrete deck; 4" x 1 3/4" x 5 lb R.S.J.; 2'6" C.R.S. with 1" cover on both top and bottom flanges; 12' span simply supported	25 psf	3 hr 35 min	-	-	7	1,2	3 1/2
FC-6-RC-32	6"	6" deep (4460 psi) concrete deck; 4" x 1 3/4" x 5 lb R.S.J.; 2" C.R.S. with 1" cover on both top and bottom flanges; 12' span simply supported	60 psf	4 hrs 30 min	-	-	7	1,10	4 1/2
FC-6-RC-33	6"	6" deep (4360 psi) concrete deck; 4" x 1 3/4" x 5 lb R.S.J.; 2" C.R.S. with 1" cover on both bottom and top flanges; 13'1" span restrained	60 psf	2 hrs	-	-	7	1,3	2

Table 3.1, continued (Floor/Ceiling Assemblies—Reinforced Concrete)

Item code	Assembly Thickness	Construction Details	Performance		Reference Number			Notes	Rec Hours
			Load	Time	Pre BMS 92	BMS	Post-BMS 92		
FC-6-RC-34	6 1/4"	6 1/4" thick; 4 3/4" (5120 psi) concrete core; 1" T&G board flooring; 1/2" plaster undercoat; 4" x 3" x 10 lb R.S.J.; 3' C.R.S. flush with top surface concrete 12' span simply supported; 2" x 1'3" clinker concrete insert	100 psf	4 hrs	-	-	7	1,7	4
FC-6-RC-35	6 1/4"	4 3/4" (3600 psi) concrete core; 1" T&G board flooring; 1/2" plaster undercoat; 4" x 3" x 10 lb R.S.J.; 3' C.R.S. flush with top surface concrete; 12' span simply supported; 2" x 1'3" clinker concrete insert	100 psf	2 hrs 30 min	-	-	7	1,5	2 1/2
FC-6-RC-36	6 1/4"	4 3/4" (2800 psi) concrete core; 1" T&G board flooring; 1/2" plaster undercoat; 4" x 3" x 10 lb R.S.J.; 3' C.R.S.; flush with top surface concrete; 12' span simply supported; 2" x 1'3" clinker concrete insert	80 psf	4hr	-	-	7	1,7	4
FC-7-RC-37	7"	(3640 psi) concrete deck; 1/4" rein. bars @ 6" pitch 1 1/2" cover; 1/4" rein. bars @ 5" pitch 1 1/2" cover perpendicular; 13'1" span restrained	169 psf	6 hr	-	-	7	1,14	6
FC-7-RC-38	7"	(4060 psi) concrete deck; 4" x 3" x 10 lb R.S.J. 2'6" C.R.S. with 1 1/2" cover on both top and bottom flanges; 4" x 6" x 13 S.W.G. mesh rein. 1 1/2" from bottom of slab; 13'1" span restrained	175 psf	6 hr	-	-	7	1,14	6
FC-7-RC-39	7 1/4"	5 3/4" (4010 psi) concrete core; 1" T&G board flooring; 1/2" plaster undercoat; 4" x 3" x 10 lb R.S.J.; 2'6" C.R.S. 1" down from top surface of concrete; 12' simply supported span; 2" x 1' 3" clinker concrete insert	95 psf	2 hrs	-	-	7	1,3	2
FC-7-RC-40	7 1/4"	5 3/4" (3220 psi) concrete core; 1" T&G board flooring; 1/2" plaster undercoat; 4" x 3" x 10 lb R.S.J.; 2'6" C.R.S. 1" down from top surface of concrete; 12' simply supported span; 2" x 1' 3" clinker concrete insert	95 psf	4 hrs	-	-	7	1,7	4
FC-7-RC-41	10" (2 1/4" slab)	Ribbed floor—see detail note 15; slab 2 1/2" deep (3020 psi); 1/4" rein. bars @ 6" pitch with 3/4" cover; beams 7 1/2" deep x 5" wide; 24" C.R.S.; 5/8" rein. bars 2 rows 1/2" vertically apart with 1" cover; 13'1" span restrained	195 psf	1 hr 4 min	-	-	7	1,2,15	1
FC-5-RC-42	5 1/2"	Composite ribbed concrete slab assembly; see note 17 for details	See note 16	2 hrs	-	-	43	16,17	2
FC-3-RC-43	3"	2500 psi concrete; 5/8" cover; fully restrained at test	See note 16	30 min	-	-	43	16	1/2
FC-3-RC-44	3"	2000 psi concrete; 5/8" cover; free or partial restraint at test	See note 16	45 min	-	-	43	16	3/4

Table 3.1, continued (Floor/Ceiling Assemblies—Reinforced Concrete)

Item code	Assem- bly Thick- ness	Construction Details	Performance		Reference Number			Notes	Rec Hours
			Load	Time	Pre BMS 92	BMS	Post-BMS 92		
FC-4-RC-45	4"	2500 psi concrete; 5/8" cover; fully restrained at test	See note 16	40 min	-	-	43	16	2/3
FC-4-RC-46	4"	2000 psi concrete; 3/4" cover; free or partial restraint at test	See note 16	1 hr 15 min	-	-	43	16	1 1/4
FC-5-RC-47	5"	2500 psi concrete; 3/4" cover; fully restrained at test	See note 16	1 hr	-	-	43	16	1
FC-5-RC-48	5"	2000 psi concrete; 3/4" cover; free or partial restraint at test	See note 16	1 hr 30 min	-	-	43	16	1 1/2
FC-6-RC-49	6"	2500 psi concrete; 1" cover; fully restrained at test	See note 16	1 hr 30 min	-	-	43	16	1 1/2
FC-6-RC-50	6"	2000 psi concrete; 1" cover; free or partial restraint at test	See note 16	2 hrs	-	-	43	16	2

Table 3.1—Notes
Floor/Ceiling Assemblies—Reinforced Concrete

1. British test.
2. Failure mode—local back face temperature rise.
3. Tested for grade "C" (2 hr) fire resistance.
4. Collapse imminent following hose stream.
5. Failure mode: flame-thru.
6. Void formed with explosive force and report.
7. Achieved grade "B" (4 hr) fire resistance (British).
8. Failure mode—collapse.
9. Test was run to 2 hrs, but specimen was partially supported by the furnace at 1 1/4 hrs
10. Failure mode: average back face temperature.
11. Recommended endurance is for non-load-bearing performance only.
12. Floor maintained load-bearing ability to 2 hrs at which point test was terminated.
13. Test was run to 3 hrs at which time failure mode 2 (above) was reached in spite of crack formation at 29 min.
14. Tested for grade "A" (6 hr) fire resistance.
15. See drawing.
16. Load unspecified.
17. Total assembly thickness 5 1/2". Three-inch thick-blocks of molded excelsior bonded with portland cement used as inserts with 2 1/2" cover (concrete) above blocks and 3/4" gypsum plaster below. Nine-inch-wide ribs containing reinforcing steel of unspecified size interrupted 20" wide segments of slab composite (i.e., plaster, excelsior blocks, concrete cover).

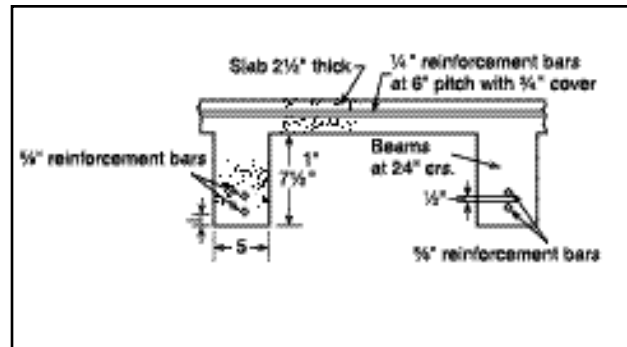

Note 15, Table 3.1

Figure 3.2
Floor/Ceiling Assemblies—Steel Structural Elements

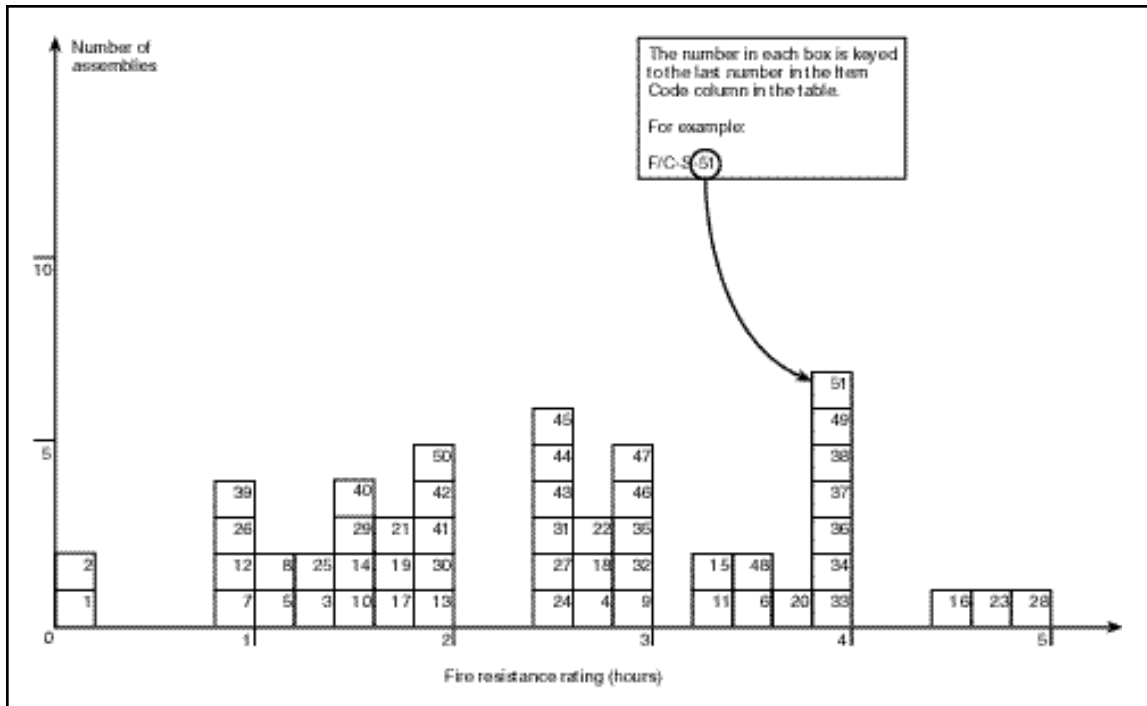

Table 3.2
Floor/Ceiling Assemblies—Steel Structural Elements

Item code	Mem-brane Thick-ness	Construction Details	Performance		Reference Number			Notes	Rec Hours
			Load	Time	Pre BMS 92	BMS	Post-BMS 92		
F/C-S-1	0"	10' x 13'6"; S.J. 103—24" O.C.; deck 2" concrete; membrane: none	145 psf	7 min	-	-	3	1,2,3,8	0
F/C-S-2	0"	10' x 13'6"; S.J. 103—24" O.C.; deck 2" concrete; membrane: none	145 psf	7 min	-	-	3	1,2,3,8	0
F/C-S-3	1/2"	10' x 13'6"; S.J. 103—24" O.C.; deck 2" concrete 1:2:4; membrane: 12" O.C. furring clips—A, B, G; no extra reinforcement; plaster 1/2" 1.5:2.5	145 psf	1 hr 15 min	-	-	3	2,3,8	1 1/4
F/C-S-4	1/2"	10' x 13'6"; S. J. 103—24" O.C.; deck 2" concrete 1:2:4; membrane: 16" O.C. furring clips—D, E, F, G; diagonal wire reinforcement; 1/2" plaster 1.5:2.5	145 psf	2 hr 46 min	-	-	3	3,8	2 3/4

Table 3.2, continued (Floor/Ceiling Assemblies—Steel Structural Elements)

Item code	Membrane Thickness	Construction Details	Performance		Reference Number			Notes	Rec Hours
			Load	Time	Pre BMS 92	BMS	Post-BMS 92		
F/C-S-5	1/2"	10' x 13'6"; S.J. 103—24" O.C.; deck 2" concrete 1:2:4; membrane: furring 16" O.C.; clip A, B, G; no extra reinforcement; plaster 1/2" 1.5:2.5	145 psf	1 hr 4 min	-	-	3	2,3,8	1
F/C-S-6	1/2"	10' x 13'6"; S.J. 103—24" O.C.; deck 2" concrete 1:2:4; membrane: furring 16" O.C.; clips—D, E, F, G; hexagonal mesh reinforcement 1/2" plaster	145 psf	3 hr 28 min	-	-	3	2,4,8	2 1/3
F/C-S-7	1/2"	10' x 13'6"; S. J. 103—24" O.C.; deck 4 lb rib lath; 6" x 6"—10 x 10 ga. reinforcement; 2" deck gravel concrete; membrane: furring 16" O.C.; clips—C.E.; reinforcement: no.; 1/2" plaster—1.5:2.5 mill mix	n/a	55 min	-	-	3	5,8	3/4
F/C-S-8	1/2"	Spec. 9' x 4'4"; S.J. 103 bar joists—18" O.C.; membrane: furring—3/4" C.R.S.—16" O.C.; clips—C.E.; reinforcement—no.; 1/2" plaster—1.5:2.5 mill mix; deck: 4 lb rib lath base; 6" x 6"—10 x 10 ga. reinforcement; 2" deck 1:2:4 gravel concrete	300 psf	1 hr 10 min	-	-	3	2,3,8	1
F/C-S-9	5/8"	10' x 13'6"; S.J. 103—24" O.C.; deck 2" concrete 1:2:4; membrane: furring 12" O.C.; clips A, B, G; extra "A" clips reinforcement: 5/8" plaster—1.5:2; 1.5:3	145 psf	3 hr	-	-	3	6,8	3
F/C-S-10	5/8"	18' x 13'6"; joists S.J.—103—24" O.C.; deck: 4 lb rib lath; 6" x 6"—10 x 10 ga. reinforcement; 2" deck—1:2:3.5 gravel concrete membrane—furring, spacing—16" O.C.; clips C.E.; reinforcement—no.; 5/8" plaster—1.5:2.5 mill mix	145 psf	1 hr 25 min	-	-	3	2,3,8	1 1/3
F/C-S-11	5/8"	10' x 13'6"; S.J. 103—24" O.C.; deck 2" concrete 1:2:4; membrane: furring 12" O.C.; clips—D, E, F, G; diagonal wire reinforcement: 5/8" plaster—1.5:2; 0.5:3	145 psf	3 hr 15 min	-	-	3	2,4,8	3 1/4
F/C-S-12	5/8"	10' x 13'6"; joists 1 SJ 103—24" O.C.; deck: 3.4 lb rib lath; reinforcement—6" x 6"—10 x 10 ga.; 2" deck—1:2:4 gravel concrete; membrane: furring 16" O.C.; clips—D, E, F, G; no reinforcement: 5/8" plaster—1.5:2.5	145 psf	1 hr	-	-	3	7,8	1

Table 3.2, continued (Floor/Ceiling Assemblies—Steel Structural Elements)

Item code	Membrane Thickness	Construction Details	Performance		Reference Number			Notes	Rec Hours
			Load	Time	Pre BMS 92	BMS	Post-BMS 92		
F/C-S-13	3/4"	Spec. 9' x 4'4"; SJ 103—18" O.C.; deck—4 lb rib. lath; 6" x 6"—10 x 10 ga. reinforcement; 2" deck 1:2:4 gravel concrete; membrane—furring 3/4" C.R.S. 16" O.C.; clips C, E; reinforcement: none; 3/4" plaster—1.5:2.5 mill mix	300 psf	1 hr 56 min	-	-	3	3,8	1 3/4
F/C-S-14	7/8"	Floor finish—1" concrete; plate cont. weld; 4"—7.7 lb I beams; ceiling—1/4" rods 12" O.C.; 7/8" gyp. sand plaster	105 psf	1 hr 35 min	-	-	6	2,4,9,10	1 1/2
F/C-S-15	1"	Floor finish—1 1/2" L.W. concrete; 1/2" limestone cement; plate cont. weld; 5"—10 lb I beams; ceiling 1/4" rods—12" O.C. tack welded to beams metal lath—1" P.C. plaster	165 psf	3 hr 20 min	-	-	6	4,9,11	-
F/C-S-16	1"	10' x 13'6"; SJ 103—24" O.C.; deck 2" concrete—1:2:4; membrane: furring 12" O.C.; clips D, E, F, G; plaster—hexagonal mesh reinforcement; 1" thick—1.5:2; 1.5:3	145 psf	4 hr 26 min	-	-	3	2,4,8	4 1/3
F/C-S-17	1"	10' x 13'6"; joists—SJ 103—24" O.C.; deck 3.4 lb rib lath; reinforcement: 6" x 6"—10 x 10 ga.; 2" deck 1:2:4 gravel concrete; membrane: furring 16" O.C.; clips D, E, F, G; 1" plaster	145 psf	1 hr 42 min	-	-	3	2,4,8	1 2/3
F/C-S-18	1 1/8"	10' x 13'6"; SJ 103—24" O.C.; deck: 2" concrete 1:2:4; membrane: furring 12" O.C.; clips C, E, F, G; diag. wire reinforcement; 1 1/8" plaster	145 psf	2 hr 44 min	-	-	3	2,4,8	2 2/3
F/C-S-19	1 1/8"	10' x 13'6"; joists—S.J. 103—24" O.C. deck—1 1/2" gypsum concrete over; 1/2" gypsum board base; membrane furring 12" O.C. plaster 1 1/8" 1.5:2; 1.5:3; clips D, E, F, G	145 psf	1 hr 40 min	-	-	3	2,3,8	1 2/3
F/C-S-20	1 1/8"	2 1/2" cinder concrete; 1/2" topping; plate 6" welds 12" O.C.; 5"—18.9 lb H center; 5"—10 lb "I" ends; 1" channel 18" O.C.; 1 1/8" gypsum sand plaster	150 psf	3 hr 43 min	-	-	6	2,4,9,11	3 2/3
F/C-S-21	1 1/4"	10' x 13'6"; joists—SJ 103—24" O.C.; deck: 1 1/2" gypsum concrete over; 1/2" gypsum board base; membrane: furring 12" O.C. clips D, E, F, G; 1 1/4" plaster 1.5:2; 1.5:3	145 psf	1 hr 48 min	-	-	3	2,3,8	1 2/3
F/C-S-22	1 1/4"	Floor finish 1 1/2" limestone concrete; 1/2" sand cement topping; plate to beam 3 1/2"; 12" O.C. welded; 5" 10 lb "I" beam; 1" channels 18" O.C.; 1 1/4" wood fiber gypsum sand plaster on metal lath	292 psf	2 hr 45 min	-	-	6	2,4,9,10	2 3/4

Table 3.2, continued (Floor/Ceiling Assemblies—Steel Structural Elements)

Item code	Mem-brane Thick-ness	Construction Details	Performance		Reference Number			Notes	Rec Hours
			Load	Time	Pre BMS 92	BMS	Post-BMS 92		
F/C-S-23	1 1/2"	2 1/2" L.W. (gas. exp.) concrete; deck: 1/2" topping; plate 6 1/4" welds 12" O.C.; beams: 5"—18.9 lb H center; 5"—10 lb "I" ends; membrane: 1" channel 18" OC; 1 1/2" gyp. sand plaster	150 psf	4 hr 42 min	-	-	6	2,4,9	4 2/3
F/C-S-24	1 1/2"	Floor finish 1 1/2" limestone concrete; 1/2" cement topping; plate 3 1/2"—12" O.C. welded; 5"—10 lb "I" beam; ceiling: 1" channel—18" O.C.; 1 1/2" gypsum plaster	292 psf	2 hr 34 min	-	-	6	2,4,9,10	2 1/2
F/C-S-25	1 1/2"	Floor finish 1 1/2" gravel concrete on exp. metal; plate—cont. weld; 4" 7.7 lb "I" beams; ceiling 1/4" rods—12" O.C. welded to beams; 1 1/2" fiber gypsum sand plaster	70 psf	1 hr 24 min	-	-	6	2,4,9,10	1 1/3
F/C-S-26	2 1/2"	Floor finish—bare plate; 6 1/4" welding—12" O.C.; 5"—18.9 lb H girder (inner); 5" 10 lb "I" girder (2 outer); 1" channel 18" O.C.; 2" reinforced gypsum tile; 1/2" gypsum sand plaster	122 psf	1 hr	-	-	6	7,9,11	1
F/C-S-27	2 1/2"	Floor finish—2" gravel concrete; plate to beam 3 1/2"—12" O.C. welded; 4" 7.7 lb "I" beams; 2" gypsum ceiling tiles; 1/2" 1:3 gypsum sand plaster	105 psf	2 hr 31 min	-	-	6	2,4,9,10	2 1/2
F/C-S-28	2 1/2"	Floor finish—1 1/2" gravel concrete; 1/2" gypsum asphalt; plate continuous weld 4"—7.7 lb "I" beam; 12" 31.8 lb "I" beam—girder @ 5' from 1 end; 1" channels 18" O.C.; 2" reinforcement gypsum tile; 1/2" 1:3 gypsum sand plaster	200 psf	4 hr 55 min	-	-	6	2,4,9,11	4 2/3
F/C-S-29	3/4"	Floor: 2" rein. concrete or 2" precast rein. gypsum tile; ceiling: 3/4" port-land cement sand plaster 1:2 scratch and 1:3 brown coat with 15 lb hydrated lime and 3 lb of short asbestos fiber bag per cement or 3/4" sanded gypsum plaster 1:2 scratch and 1:3 brown coat	See note 12	1 hr 30 min	-	1	-	12,13,14	1 1/2
F/C-S-30	3/4"	Floor: 2 1/4" rein. concrete or 2" rein. gypsum tile; the latter with 1/4" mortar finish; ceiling 3/4" sanded gypsum plaster; 1:2 for scratch coat and 1:3 for brown coat	See note 12	2 hr	-	1	-	12,13,14	2
F/C-S-31	3/4"	Floor: 2 1/2" rein. concrete or 2" rein. gypsum tile; the latter with 1/4" mortar finish; ceiling: 1" neat gypsum plaster or 3/4" gypsum vermiculite plaster ratio of gypsum to fine vermiculite 2:1 to 3:1	See note 12	2 hr 30 min	-	1	-	12,13,14	2 1/2

Table 3.2, continued (Floor/Ceiling Assemblies—Steel Structural Elements)

Item code	Mem-brane Thickness	Construction Details	Performance		Reference Number			Notes	Rec Hours
			Load	Time	Pre BMS 92	BMS	Post-BMS 92		
F/C-S-32	3/4"	Floor: 2 1/2" rein. concrete or 2" rein. gypsum tile; the latter with 1/2" mortar finish; ceiling: 1" neat gypsum plaster or 3/4" gypsum-vermiculite plaster ratio of gypsum to fine vermiculite 2:1 to 3:1	See note 12	3 hr	-	1	-	12,13,14	3
F/C-S-33	1"	Floor: 2 1/2" rein. concrete, or 2" rein. gypsum slabs, the latter with 1/2" mortar finish; ceiling: 1" gypsum vermiculite plaster applied on metal lath and ratio 2:1 to 3:1 gypsum to vermiculite by weight	See note 12	4 hr	-	1	-	12,13,14	4
F/C-S-34	2 1/2"	Floor: 2" rein. concrete or 2" precast rein. portland cement concrete or gypsum slabs, precast slabs to be finished with 1/4" mortar top coat; ceiling: 2" precast reinforced gypsum tile, anchored into beams with metal ties or clips and covered with 1/2" 1:3 sanded gypsum plaster	See note 12	4 hr	-	1	-	12,13,14	4
F/C-S-35	1"	Floor: 1:3:6 portland cement, sand, and gravel concrete applied directly to the top of steel units and 1 1/2" thick at top of cells, plus 1/2" 1:2 1/2" cement-sand finish, total thickness at top of cells, 2"; ceiling: 1" neat gypsum plaster, back of lath 2" or more from underside of cellular steel	See note 15	3 hr	-	1	-	15,16,17,18	3
F/C-S-36	1"	Floor: same as F/C-S-35; ceiling: 1" gypsum vermiculite plaster (ratio of gypsum to vermiculite 2:1 to 3:1), the back of lath 2" or more from underside of cellular steel	See note 15	4 hr	-	1	-	15,16,17,18	4
F/C-S-37	1"	Floor: same as F/C-S-35; ceiling: 1" neat gypsum plaster; back of lath 9" or more from underside of cellular steel	See note 15	4 hr	-	1	-	15,16,17,18	4
F/C-S-38	1"	Floor: same as F/C-S-35; ceiling: 1" gypsum vermiculite plaster (ratio of gypsum to vermiculite 2:1 to 3:1) the back of lath being 9" or more from underside of cellular steel	See note 15	5 hr	-	1	-	15,16,17,18	5
F/C-S-39	3/4"	Floor: asbestos paper 14 lb/100ft ² cemented to steel deck with water-proof linoleum cement, wood screeds and 7/8" wood floor; ceiling: 3/4" sanded gypsum plaster 1:2 for scratch and 1:3 for browncoat	See note 19	1 hr	-	1	-	19,20,21,22	1
F/C-S-40	3/4"	Floor: 1 1/2" 1:2:4 portland cement concrete; ceiling: 3/4" sanded gypsum plaster 1:2 for scratch and 1:3 browncoat	See note 19	1 hr 30 min	-	1	-	19,20,21,22	1 1/2

Table 3.2, continued (Floor/Ceiling Assemblies—Steel Structural Elements)

Item code	Mem-brane Thick-ness	Construction Details	Performance		Reference Number			Notes	Rec Hours
			Load	Time	Pre BMS 92	BMS	Post-BMS 92		
F/C-S-41	3/4"	Floor: 2" 1:2:4 portland cement concrete; ceiling 3/4" sanded gypsum plaster 1:2 for scratch and 1:3 brown coat	See note 19	2 hr	-	1	-	19,20,21,22	2
F/C-S-42	1"	Floor: 2" 1:2:4 portland cement concrete; ceiling: 1" portland cement sand plaster with 10 lb of hydrated lime for a bag of cement 1:2 1/2 for brown coat and 1:2 scratch coat	See note 19	2 hr	-	1	-	19,20,21,22	2
F/C-S-43	1 1/2"	Floor: 2", 1:2:4 portland cement concrete; ceiling: 1 1/2", 1:2 sanded gypsum plaster on ribbed metal lath	See note 19	2 hr 30 min	-	1	-	19,20,21,22	2 1/2
F/C-S-44	1 1/8"	Floor: 2" 1:2:4 portland cement concrete; ceiling 1 1/8", 1:1 sanded gypsum plaster	See note 19	2 hr 30 min	-	1	-	19,20,21,22	2 1/2
F/C-S-45	1"	Floor: 2 1/2" 1:2:4 portland cement concrete; ceiling: 1", 1:2 sanded gypsum plaster	See note 19	2 hr 30 min	-	1	-	19,20,21,22	2 1/2
F/C-S-46	3/4"	Floor: 2 1/2" 1:2:4 portland cement concrete; ceiling: 1" neat gypsum plaster or 3/4" gypsum vermiculite plaster, ratio of gypsum to vermiculite 2:1 to 3:1.	See note 19	3 hr	-	1	-	19,20,21,22	3
F/C-S-47	1 1/8"	Floor: 2 1/2" 1:2:4 portland cement, sand and cinder concrete plus 1/2", 1:2 1/2 cement-sand finish; total thickness 3"; ceiling: 1 1/8", 1:1 sanded gypsum plaster	See note 19	3 hr	-	1	-	19,20,21,22	3
F/C-S-48	1 1/8"	Floor: 2 1/2" gas expanded portland cement sand concrete plus 1/2", 1:2 1/2 cement-sand finish; total thickness 3"; ceiling: 1 1/8", 1:1 sanded gypsum plaster	See note 19	3 hr 30 min	-	1	-	19,20,21,22	3 1/2
F/C-S-49	1"	Floor: 2 1/2" 1:2:4 portland cement concrete; ceiling: 1" gypsum vermiculite plaster; ratio of gypsum to vermiculite 2:1 to 3:1	See note 19	4 hr	-	1	-	19,20,21,22	4
F/C-S-50	2 1/2"	Floor: 2" 1:2:4 portland cement concrete; ceiling 2" interlocking gypsum tile supported on upper face of lower beam flange, 1/2" 1:3 sanded gypsum plaster	See note 19	2 hr	-	1	-	19,20,21,22	2
F/C-S-51	2 1/2"	Floor: 2" 1:2:4 portland cement concrete; ceiling: 2" precast metal rein. gypsum tile 1/2" 1:3 sanded gypsum plaster (tile clipped to channels that are clipped to lower flange of beams)	See note 19	4 hr	-	1	-	12,20,21,22	4

Table 3.2—Notes***Floor/Ceiling Assemblies—Steel Structural Elements***

1. No protective membrane over structural steel.
2. Performance time indicates first end point reached; only several tests were continued to points where other failures occurred.
3. Load failure.
4. Thermal failure.
5. This is an estimated time to load bearing failure. The same joist and deck specimen was used for a later test with different membrane protection.
6. Test stopped at 3 hr to reuse specimen; no end point reached.
7. Test stopped at 1 hr to reuse specimen; no end point reached.
8. All plaster used = gypsum.
9. Specimen size—18' x 13 1/2'. Floor deck base material—1/4" x 18' steel plate welded to I beam.
10. I beams—24" O.C.
11. I beams—48" O.C.
12. Apply to open web joints, pressed steel joists, or rolled steel beams, which are not stressed beyond 18,000 lb/in² in flexure for open-web pressed, or light rolled steel joists and 20,000 lb/in² for American standard or heavier rolled beams.
13. Ratio of weight of portland cement to fine and coarse aggregates combined for floor slabs shall not be less than 1:6 1/2.
14. Plaster for ceiling shall be applied on metal lath that shall be tied to supports to give the equivalent of single No. 18 gauge steel wires 5" O.C.
15. Load: maximum fiber stress in steel not to exceed 16,000 psi.
16. Prefabricated units 2 ft. wide with length equal to the span, composed of 2 pieces of No. 18 gauge formed steel welded together to give 4 longitudinal cells.
17. Depth not less than 3" and distance between cells not less than 2".
18. Ceiling: metal lath tied to furring channels secured to runner channels hung from cellular steel.
19. Load: rolled steel supporting beams and steel plate base shall not be stressed beyond 20,000 psi in flexure. Formed steel (with wide upper flange) construction shall not be stressed beyond 16,000 psi.
20. Some type of expanded metal or woven wire shall be imbedded to prevent cracking in concrete flooring.
21. Ceiling plaster shall be on metal lath wired to rods or channels that are clipped or welded to steel construction. Lath shall be no smaller than 18 gauge steel wire and not more than 7" O.C.
22. The securing rods or channels shall be at least as effective as single 3/16" rods with 1" of their length bent over the lower flanges of beams with the rods or channels tied to this clip with 14 gauge iron wire.

Figure 3.3
Floor/Ceiling Assemblies—Wood Joist

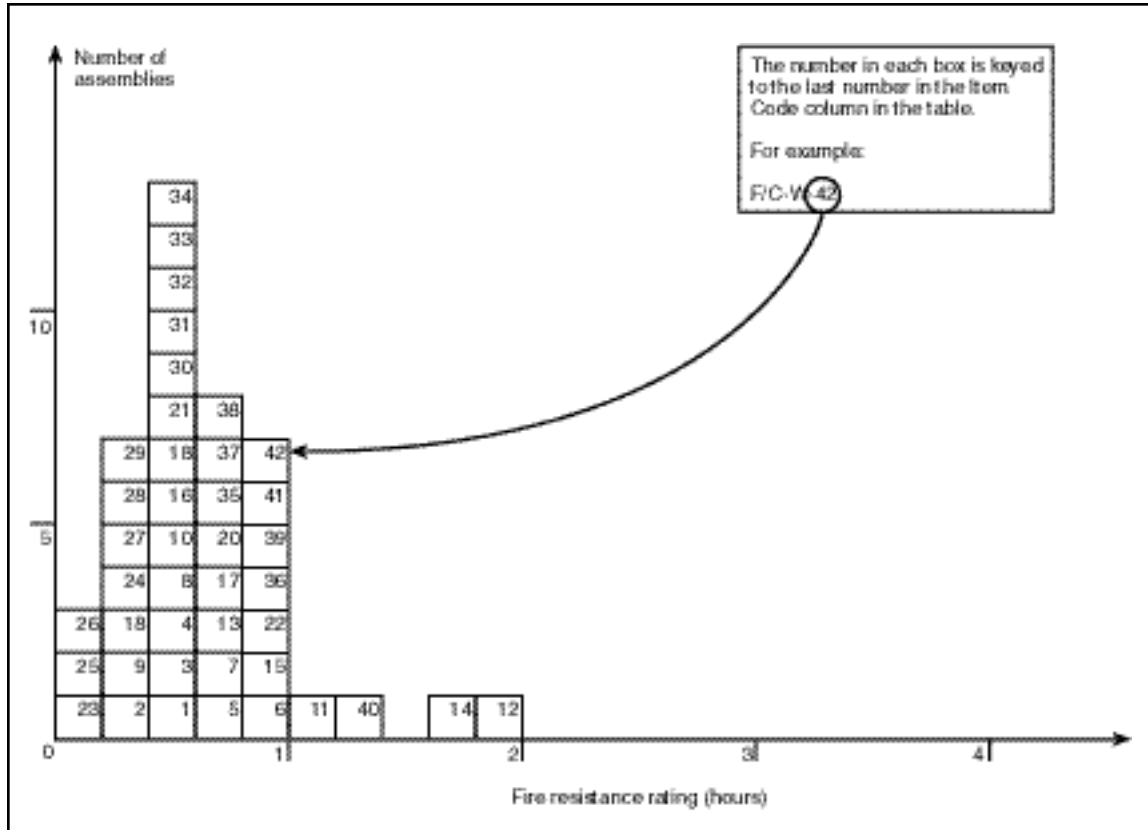

Table 3.3
Floor/Ceiling Assemblies—Wood Joist

Item Code	Membrane Thickness	Construction Details	Performance		Reference Number			Notes	Rec Hours
			Load	Time	Pre BMS 92	BMS	Post-BMS 92		
F/C-W-1	3/8"	12' clear span—2" x 9" wood joists; 18" O.C.; deck—1" T&G; filler: 3" of ashes on 1/2" boards nailed to joist sides 2" from bottom; 2" air space; membrane—3/8" gypsum board	60 psf	36 min	-	-	7	1,2	1/2
F/C-W-2	1/2"	12' clear span 2" x 7" joists; 15" O.C.; 2" x 1-1/2" center bridging at center; deck—1" nominal lumber; membrane—1/2" fiberboard	60 psf	22 min	-	-	7	1,2,3	1/4
F/C-W-3	1/2"	12' clear span—2" x 7" wood joists, 16" O.C. 2" x 1 1/2" bridging at center; deck—1" T&G; membrane—1/2" fiberboard; 2 coats "distemper" paint	30 psf	28 min	-	-	7	1,3,15	1/3

Table 3.3, continued (Floor/Ceiling Assemblies—Wood Joist)

Item Code	Membrane Thickness	Construction Details	Performance		Reference Number			Notes	Rec Hours
			Load	Time	Pre BMS 92	BMS	Post-BMS 92		
F/C-W-4	3/16"	12' clear span—2" x 7" wood joists; 16" O.C. 2" x 1 1/2" bridging at center span; deck: 1" nominal lumber; membrane: 1/2" fiberboard under 3/16" gypsum plaster	30 psf	32 min	-	-	7	1,2	1/2
F/C-W-5	5/8"	As per F/C-W-4 except membrane is 5/8" lime plaster.	70 psf	48 min	-	-	7	1,2	3/4
F/C-W-6	5/8"	As per F/C-W-5 except membrane is 5/8" gypsum plaster on 22 gauge 3/8" metal lath	70 psf	49 min	-	-	7	1,2	3/4
F/C-W-7	1/2"	As per F/C-W-6 except membrane is 1/2" fiberboard under 1/2" gypsum plaster	60 psf	43 min	-	-	7	1,2,3	2/3
F/C-W-8	1/2"	As per F/C-W-7 except membrane is 1/2" gypsum board	60 psf	33 min	-	-	7	1,2,3	1/2
F/C-W-9	9/16"	12' clear span—2" x 7" wood joists; 15" O.C. 2" x 1 1/2" center bridging; deck—1" nominal lumber; membrane—3/8" gypsum board; 3/16" gypsum plaster	60 psf	24 min	-	-	7	1,2,3	1/3
F/C-W-10	5/8"	As per F/C-W-9 except membrane is 5/8" gypsum plaster on wood lath	60 psf	27 min	-	-	7	1,2,3	1/3
F/C-W-11	7/8"	12' clear span—2" x 9" wood joists; 15" O.C. 2" x 1 1/2" bridging at center span; deck—1" T&G; membrane—original ceiling joists have 3/8" plaster on wood lath; 4" metal hangers attached below joists creating 15" chases filled with mineral wool and closed with 7/8" plaster (gypsum) on 3/8" S.W.M. metal lath to form new ceiling surface	75 psf	1 hr 10 min	-	-	7	1,2	1
F/C-W-12	7/8"	12' clear span—2" x 9" wood joists; 15" O.C. 2" x 1 1/2" bridging at center; deck—1" T&G; membrane—3" mineral wool below joists; 3" hangers to channel below joists; 7/8" gypsum plaster on metal lath attached to channels	75 psf	2 hrs	-	-	7	1,4	2
F/C-W-13	7/8"	12' clear span—2" x 9" wood joists—16" O.C. 2" x 1 1/2" bridging at center span; deck: 1" T&G on 1" bottoms on 3/4" glass wool strips on 3/8" gypsum board nailed to joists; membrane 3/4" glass wool strips on joists; 3/8" perf. gypsum lath; 1/2" gypsum plaster	60 psf	41 min	-	-	7	1,3	2/3

Table 3.3, continued (Floor/Ceiling Assemblies—Wood Joist)

Item Code	Mem-brane Thickness	Construction Details	Performance		Reference Number			Notes	Rec Hours
			Load	Time	Pre BMS 92	BMS	Post-BMS 92		
F/C-W-14	7/8"	12' clear span—2" x 9" wood joists—15" O.C. deck: 1" T&G; mem-brane—3" foam concrete in cavity on 1/2" boards nailed to joists; wood lath nailed to 1" x 1 1/4" straps 14" O.C. across joists; 7/8" gypsum plaster	60 psf	1 hr 40 min	-	-	7	1,5	1 2/3
F/C-W-15	7/8"	12' clear span—2" x 9" wood joists—18" O.C. deck 1" T&G; membrane: 2" foam concrete on 1/2" boards nailed to joist sides 2" from joists bottom; 2" airspace; 1" x 1 1/4" wood straps 14" O.C. across joists; 7/8" lime plaster on wood lath	60 psf	53 min	-	-	7	1,2	3/4
F/C-W-16	7/8"	12' clear span—2" x 9" wood joists; deck: 1" T&G; membrane: 3" ashes on 1/2" boards nailed to joist sides 2" from joist bottom; 2" air space; 1" x 1 1/4" wood straps 14" O.C.; 7/8" gypsum plaster on wood lath	60 psf	28 min	-	-	7	1,2	1/3
F/C-W-17	7/8"	As per F/C-W-16 but with lime plaster mix	60 psf	41 min	--	-	7	1,2	2/3
F/C-W-18	7/8"	12' clear span—2" x 9" wood joists—18" O.C. 2" x 1 1/2" center bridging; deck: 1" T&G; membrane: 7/8" gypsum plaster on wood lath	60 psf	36 min	-	-	7	1,2	1/2
F/C-W-19	7/8"	As per F/C-W-18 except with lime plaster membrane and deck is 1" nominal boards (plain edge)	60 psf	19 min	-	-	7	1,2	1/4
F/C-W-20	7/8"	As per F/C-W-19 except deck is 1" T&G boards	60 psf	43 min	-	-	7	1,2	2/3
F/C-W-21	1"	12' clear span—2" x 9" wood joists—16" O.C. 2" x 1 1/2" center bridging; deck: 1" T&G; membrane: 3/8" gypsum baseboard; 5/8" gypsum plaster	70 psf	29 min	-	-	7	1,2	1/3
F/C-W-22	1 1/8"	12' clear span—2" x 9" wood joists—16" O.C. bridging 2" x 2" wood at center; deck: 1" T&G; membrane: hangers, channel with 3/8" gypsum baseboard affixed under 3/4" gypsum plaster	60 psf	1 hr	-	-	7	1,2,3	1
F/C-W-23	3/8"	Deck: 1" nominal lumber; joists: 2" x 7", 15" O.C.; membrane: 3/8" plasterboard with plaster skim coat	60 psf	11 1/2 min	-	-	12	2,6	1/6
F/C-W-24	1/2"	Deck: 1" T&G lumber; joists: 2" x 9", 16" O.C.; membrane: 1/2" plaster-board	60 psf	18 min	-	-	12	2,7	1/4
F/C-W-25	1/2"	Deck: 1" T&G lumber; joists: 2" x 7", 16" O.C.; membrane: 1/2" fiber insulation board	30 psf	8 min	-	-	12	2,8	2/15

Table 3.3, continued (Floor/Ceiling Assemblies—Wood Joist)

Item Code	Membrane Thickness	Construction Details	Performance		Reference Number			Notes	Rec Hours
			Load	Time	Pre BMS 92	BMS	Post-BMS 92		
F/C-W-26	1/2"	Deck: 1" nominal lumber; joists: 2" x 7", 15" O.C.; membrane: 1/2" fiber insulation board	60 psf	8 min	-	-	12	2,9	2/15
F/C-W-27	5/8"	Deck: 1" nominal lumber; joists: 2" x 7", 15" O.C.; membrane: 5/8" gypsum plaster on wood lath	60 psf	17 min	-	-	12	2,10	1/4
F/C-W-28	5/8"	Deck: 1" T&G lumber; joists: 2" x 9", 16" O.C.; membrane: 1/2" fiber insulation board: 1/2" plaster	60 psf	20 min	-	-	12	2,11	1/3
F/C-W-29	No membrane	Exposed wood joists	See note 13	15 min	-	1	-	1,12,13,14	1/4
F/C-W-30	3/8"	Gypsum wallboard: 3/8" or 1/2" with 1 1/2" No. 15 gauge nails with 3/16" heads spaced 6" centers with asbestos paper applied with paper-hangers paste and finished with casein paint	See note 13	25 min	-	1	-	1,12,13,14	1/2
F/C-W-31	1/2"	Gypsum wallboard: 1/2" with 1 3/4" No. 12 gauge nails with 1/2" heads, 6" O.C. and finished with casein paint	See note 13	25 min	-	1	-	1,12,13,14	1/2
F/C-W-32	1/2"	Gypsum wallboard: 1/2" with 1 1/2" No. 12 gauge nails with 1/2" heads, 18" O.C. with asbestos paper applied with paper hangers paste and secured with 1 1/2" No. 15 gauge nails with 3/16" heads and finished with casein paint; combined nail spacing 6" O.C.	See note 13	30 min	-	1	-	1,12,13,14	1/2
F/C-W-33	3/8"	Gypsum wallboard: 2 layers 3/8" secured with 1 1/2" No. 15 gauge nails with 3/8" heads, 6" O.C.	See note 13	30 min	-	1	-	1,12,13,14	1/2
F/C-W-34	1/2"	3/8" perforated gypsum lath—plastered with 1 1/8" No. 13 gauge nails with 5/16" heads; 4" O.C.; 1/2" sanded gypsum plaster	See note 13	30 min	-	1	-	1,12,13,14	1/2
F/C-W-35	1/2"	Same as F/C-W-34 except with 1 1/8" No. 13 gauge nails with 3/8" heads; 4" O.C.	See note 13	45 min	-	1	-	1,12,13,14	3/4
F/C-W-36	1/2"	3/8" perforated gypsum lath nailed with 1 1/8" No. 13 gauge nails with 3/8" heads; 4" O.C.; joints covered with 3" strips of metal lath; with 1 3/4" No. 12 gauge nails with 1/2" heads; 5" O.C. 1/2" sanded gypsum plaster	See note 13	1 hr	-	1	-	1,12,13,14	1

Table 3.3, continued (Floor/Ceiling Assemblies—Wood Joist)

Item Code	Membrane Thickness	Construction Details	Performance		Reference Number			Notes	Rec Hours
			Load	Time	Pre BMS 92	BMS	Post-BMS 92		
F/C-W-37	1/2"	Gypsum lath—3/8" and lower layer of 3/8" perforated gypsum lath nailed with 1 3/4" No. 13 gauge nails with 5/16" heads and 4" O.C.; 1/2" sanded gypsum plaster or 1/2" portland cement plaster	See note 13	45 min	-	1	-	1,12,13,14	3/4
F/C-W-38	3/4"	Metal lath: nailed with 1 1/4" No. 11 gauge nails with 3/8" heads or 6d common driven 1" and bent over; 6" O.C.; 3/4" sanded gypsum plaster	See note 13	45 min	-	1	-	1,12,13,14	3/4
F/C-W-39	3/4"	Same as F/C-W-38 except nailed with 1 1/2" No. 11 barbed roof nails with 7/16" heads, 6" O.C.	See note 13	1 hr	-	1	-	1,12,13,14	1
F/C-W-40	3/4"	Same as F/C-W-38 except with lath nailed to joists with additional supports for lath, 27" O.C.; attached to alternate joists and consisting of 2 nails driven 1 1/4", 2" above bottom on opposite sides of the joists, one loop of No. 18 wire slipped over each nail; the ends twisted together below lath	See note 13.	1 hr 15 min	-	1	-	1,12,13,14	1 1/4
F/C-W-41	3/4"	Metal lath with 1 1/2" No. 11 barbed roof nails with 7/16" heads, 6" O.C. with 3/4" portland cement plaster for scratch and 1:3 for brown coat, 3 lb of asbestos fiber and 15 lb of hydrated lime per 94 lb bag of cement	See note 13	1 hr	-	1	-	1,12,13,14	1
F/C-W-42	3/4"	Metal lath nailed with 8d, 11 1/2 gauge barbed box nails 2 1/2" driven 1 1/4" on slant and bent over; 6" O.C.; 3/4" sanded gypsum plaster 1:2 scratch coat and 1:3 below coat	See note 13	1 hr	-	1	-1	1,12,13,14	1

Table 3.3—Notes
Floor/Ceiling Assemblies—Wood Joist

1. Thickness indicates thickness of first membrane protection on ceiling surface.
2. Failure mode—flame thru.
3. Failure mode—collapse.
4. No end point reached at termination of test.
5. Failure imminent—test terminated.
6. Joist failure—11 1/2 min., flame thru—13 min., collapse—24 min.
7. Joist failure—17 min., flame thru—18 min., collapse—33 min.
8. Joist failure—18 min., flame thru—8 min., collapse—30 min.
9. Joist failure—12 min., flame thru—8 min., collapse—22 min.
10. Joist failure—11 min., flame thru—17 min., collapse—27 min.

11. Joist failure—17 min., flame thru—20 min., collapse—43 min.
12. Joists: 2" x 10" southern pine or Douglas fir; No. 1 common or better; sub-floor: 3/4" wood sheathing diaphragm of asbestos paper, and finish of tongue and groove wood flooring.
13. Loadings: not more than 1000 psi maximum fiber stress in joists.
14. Perforations in gypsum lath are to be not less than 3/4" diameter with one perforation for not more than 16/in² diameter.
15. "Distemper" is a British term for a water-based paint such as whitewash or calcimine.

Figure 3.4
Floor/Ceiling Assemblies—Hollow Clay Tile with Reinforced Concrete

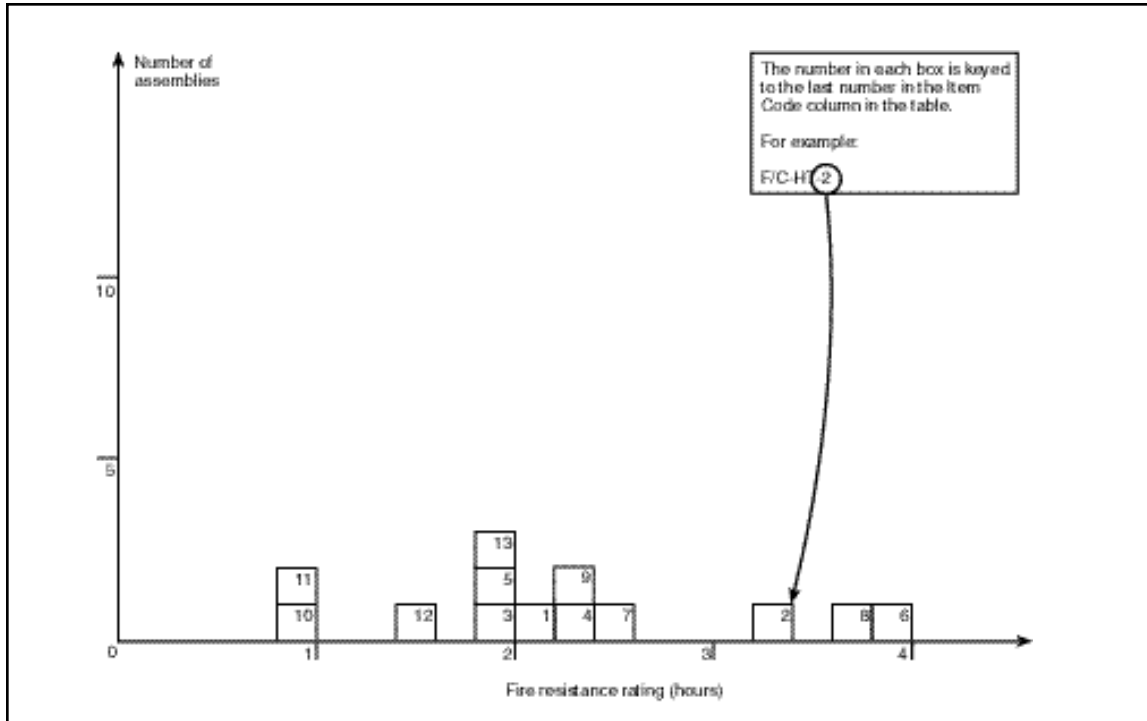

Table 3.4
Floor/Ceiling Assemblies—Hollow Clay Tile with Reinforced Concrete

Item Code	Assem. Thickness	Construction Details	Performance		Reference Number			Notes	Rec Hours
			Load	Time	Pre BMS 92	BMS	Post-BMS 92		
F/C-HT-1	6"	Cover: 1 1/2" concrete (6080 psi); 3 cell hollow clay tiles; 12" x 12" x 4"; 3 1/4" concrete between tiles including 2—1/2" rebars with 3/4" concrete cover; 1/2" plaster cover, lower	75 psf	2 hrs 7 min	-	-	7	1,2,3	2
F/C-HT-2	6"	Cover: 1 1/2" concrete (5840 psi); 3 cell hollow clay tiles; 12" x 12" x 4"; 3 1/4" concrete between tile including 2—1/2" rebars each with 1/2" concrete cover and 5/8" filler tiles between hollow tiles; 1/2" plaster cover, lower	61 psf	3 hrs 23 min	-	-	7	3,4,6	3 1/3
F/C-HT-3	6"	Cover: 1 1/2" concrete (6280 psi); 3 cell hollow clay tiles 12" x 12" x 4"; 3 1/4" concrete between tiles including 2—1/2" rebars with 1/2" cover; 1/2" plaster cover, lower	122 psf	2 hrs	-	-	7	1,3,5,8	2

Table 3.4, continued (Floor/Ceiling Assemblies—Hollow Clay Tile with Reinforced Concrete)

Item Code	Assemb. Thickness	Construction Details	Performance		Reference Number			Notes	Rec Hours
			Load	Time	Pre BMS 92	BMS	Post-BMS 92		
F/C-HT-4	6"	Cover: 1 1/2" concrete (6280 psi); 3 cell hollow clay tiles 12" x 12" x 4"; 3 1/4" concrete between tiles including 2—1/2" rebars with 3/4" concrete cover; 1/2" plaster cover, lower	115 psf	2 hrs 23 min.	-	-	7	1,3,7	2 1/3
F/C-HT-5	6"	Cover: 1 1/2" concrete (6470 psi); three-cell hollow clay tiles 12" x 12" x 4"; 3 1/4" concrete between tiles including 2—1/2" rebars with 1/2" cover; 1/2" plaster cover, lower	122 psf	2 hrs	-	-	7	1,3,5,8	2
F/C-HT-6	8"	Floor cover: 1 1/2" gravel cement (4300 psi); tiles: three-cell 12" x 12" x 6"; 3 1/2" space between tiles including 2—1/2" rebars with 1" cover from concrete bottom; 1/2" plaster cover, lower	165 psf	4 hrs	-	-	7	1,3,9,10	4
F/C-HT-7	9" (nom)	Deck: 7/8" T&G on 2" x 1 1/2" bottoms (18" O.C.) 1 1/2" concrete cover (4600 psi); 3 cell hollow clay tiles 12" x 12" x 4"; 3" concrete between tiles including 1—3/4" rebar 3/4" from tile bottom; 1/2" plaster cover	95 psf	2 hrs 26 min	-	-	7	4,11,12,13	2 1/3
F/C-HT-8	9" (nom)	Deck: 7/8" T&G on 2" x 1 1/2" bottoms (18" O.C.) 1 1/2" concrete cover with 3850 psi; 3 cell hollow clay tiles 12" x 12" x 4"; 3" concrete between tiles including 1—3/4" rebar 3/4" from tile bottoms; 1/2" plaster cover	95 psf	3 hrs 28 min	-	-	7	4,11,12,13	-
F/C-HT-9	9" (nom)	Deck: 7/8" T&G on 2" x 1 1/2" bottoms (18" O.C.) 1 1/2" concrete cover (4200 psi); 3 cell hollow clay tiles 12" x 12" x 4"; 3" concrete between tiles including 1—3/4" rebar 3/4" from tile bottoms; 1/2" plaster cover	95 psf	2 hrs 14 min	-	-	7	3,5,8,11	-
F/C-HT-10	5 1/2"	Fire clay tile (4" thick); 1 1/2" concrete cover; for general details see note 15	See note 14	1 hr	-	-	43	15	1
F/C-HT-11	8"	Fire clay tile (6" thick); 2" cover	See note 14	1 hr	-	-	43	15	1
F/C-HT-12	5 1/2"	Fire clay tile (4" thick); 1 1/2" cover; 5/8" gypsum plaster, lower	See note 14	1 hr 30 min	-	-	43	15	1 1/2
F/C-HT-13	8"	Fire clay tile (6" thick); 2" cover; 5/8" gypsum plaster, lower	See note 14	2 hrs	-	-	43	15	1 1/2

Table 3.4—Notes**Floor/Ceiling Assemblies—Hollow Clay Tile With Reinforced Concrete**

1. A generalized cross section of this floor type follows. See figure below.
2. Failure mode—structural.
3. Plaster-base coat—lime-cement-sand; top coat—gypsum (neat).
4. Failure mode—collapse.
5. Test stopped before any end points were reached.
6. A generalized cross section of this floor type follows. See figure below.
7. Failure mode—thermal; back face temperature rise.
8. Passed hose stream test.

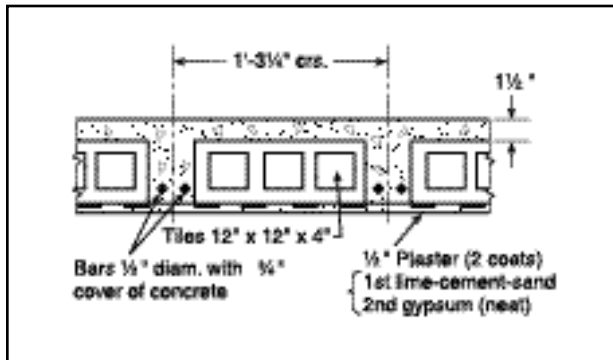

Note 1, Table 3.4

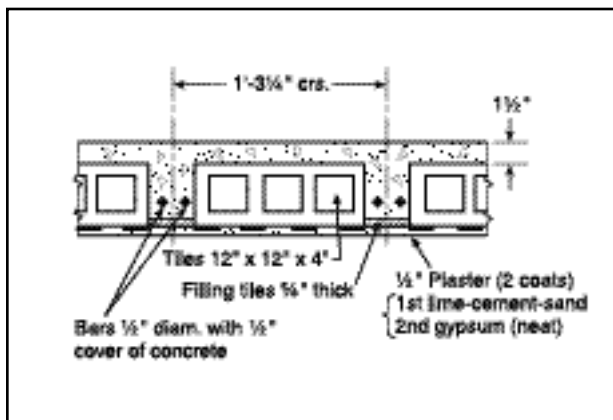

Note 6, Table 3.4

9. Failed hose stream test.
10. Test stopped at 4 hrs before any end points were reached.
11. A generalized cross section of this floor type follows. See figure below.
12. Plaster-base coat—retarded hemihydrate gypsum-sand; second coat—neat gypsum.
13. Concrete in item 7 is P.C.-based but with crushed brick aggregates, while in item 8 river sand and river gravels are used with the P.C.
14. Load—unspecified.
15. The 12" x 12" fire-clay tiles were laid end to end in rows spaced 2 1/2" or 4" apart. The reinforcing steel was placed between these rows and the concrete cast around them and over the tile to form the structural floor.

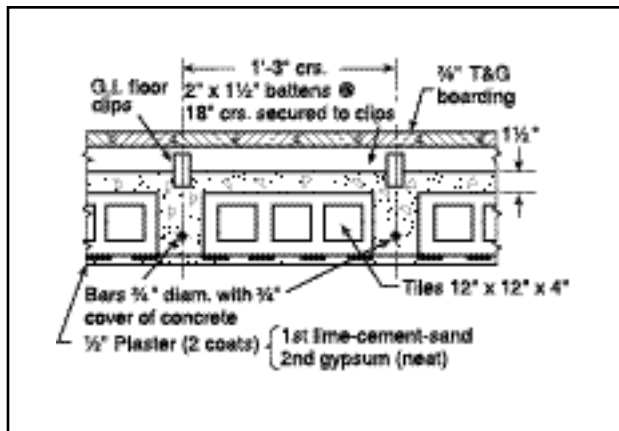

Note 11, Table 3.4

SECTION IV—Beams

Table 4.1.1
Reinforced Concrete Beams
Depth 10" (250 mm) to less than 12" (300 mm)

Item Code	Depth	Construction Details	Performance		Reference Number			Notes	Rec Hours
			Load	Time	Pre BMS 92	BMS	Post-BMS 92		
B-11-RC-1	11"	24" wide x 11" deep reinforced concrete T beam (3290 psi); details: see figure, note 5	8.8 tons	4 hrs 2 min	-	-	7	1,2,14	4
B-10-RC-2	10"	24" wide x 10" deep reinforced concrete T beam (4370 psi); details: see figure, note 6	8.8 tons	1 hr 53 min	-	-	7	1,3	1 3/4
B-10-RC-3	10 1/2"	24" wide x 10 1/2" deep reinforced T beam (4450 psi) concrete; details: see figure, note 7	8.8 tons	2 hrs 40 min	-	-	7	1,3	2 2/3
B-11-RC-4	11"	24" wide x 11" deep reinforced concrete T beam (2400 psi); details: see figure, note 8.	8.8 tons	3 hrs 32 min	-	-	7	1,3,14	3 1/2
B-11-RC-5	11"	24" wide x 11" deep reinforced concrete T beam (4250 psi); details: see figure, note 9	8.8 tons	3 hrs 3 min	-	-	7	1,3,14	3
B-11-RC-6	11"	Concrete flange: 4" deep x 2' wide (4895 psi) concrete; 7" deep 6 1/2" wide beam; I beam reinforcement: 10" x 4 1/2" x 25 lb R.S.J.; 1" cover on flanges; rein.: 3/8" diam. bars @ 6" pitch parallel to T; 1/4" diam. bars perpendicular to T; 4" x 6" wire mesh #13 SWG; span—11' restrained; details: see figure, note 10	10 tons	6 hrs	-	-	7	1,4	6
B-11-RC-7	11"	Concrete flange: 6" deep x 1'6 1/2" wide (3525 psi) concrete; 5" deep 8" wide precast concrete blocks 8 3/4" long; I beam reinforcement: 7" x 4" x 16 lb R.S.J. 2" cover on bottom; 1 1/2" cover on top; 2 rows 1/2" diam. rods parallel to T; 1/8" wire mesh perpendicular to T; span 1'3" simply supported; details: see figure, note 11	3.9 tons	4 hrs	-	-	7	1,2	4
B-11-RC-8	11"	Concrete flange: 4" x 2" (3525 psi) concrete; 7" x 4 1/2" (scaled fr. drawing) I beam reinforcement; 10" x 4 1/2" x 25 lb R.S.J.; no concrete cover on bottom; rein.: 3/8" diam. bars @ 6" pitch parallel to T; 1/4" diam. bars perpendicular to T; span: 11" restricted	10 tons	4 hrs	-	-	7	1,2,12	4
B-11-RC-9	11 1/2"	24" wide x 11 1/2" deep reinforced concrete T beam (4390 psi); details: see figure, note 12	8.8 tons	3 hrs 24 min	-	-	7	1,3	3 1/3

Table 4.1.1—Notes

Reinforced Concrete Beams, depth 10" to less than 12"

1. Load concentrated at mid-span.
2. Achieved 4-hr performance (Class "B"—British).
3. Failure mode—collapse.
4. Achieved 6-hr performance (Class "A"—British).
5. See figure below.
6. See figure below.
7. See figure below.
8. See figure below.
9. See figure opposite.
10. See figure opposite.
11. See figure opposite.
12. See figure opposite.
13. See figure opposite.
14. The different performances achieved by B-11-RC-1, B-11-RC-4, and B-11-RC-5 are attributable to differences in concrete aggregate compositions reported in the source document but unreported in this table. This demonstrates the significance of material composition in addition to other details.

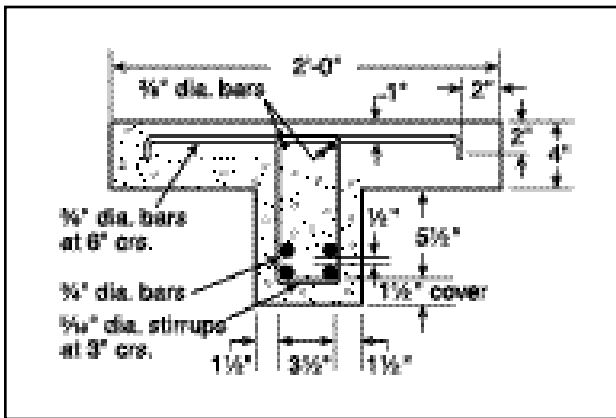

Note 5, Table 4.1.1

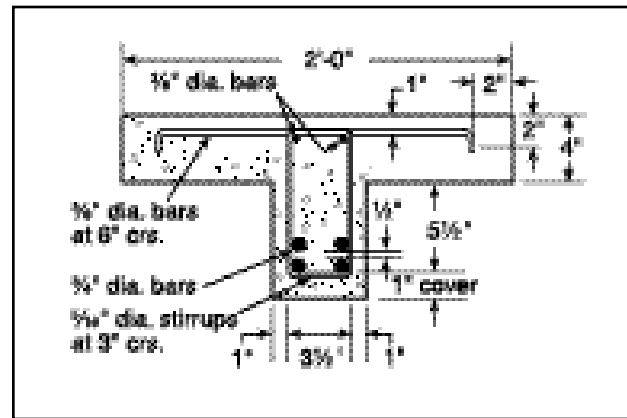

Note 7, Table 4.1.1

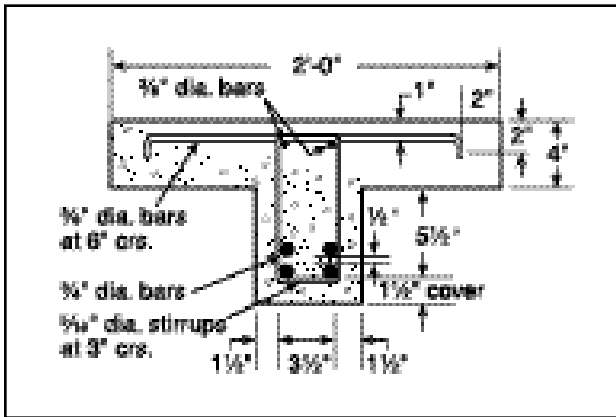

Note 6, Table 4.1.1

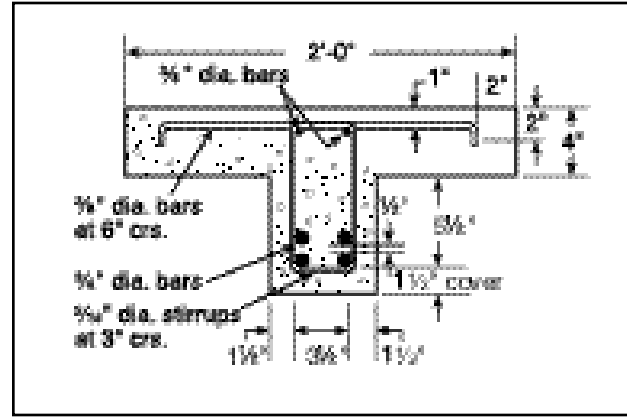

Note 8, Table 4.1.1

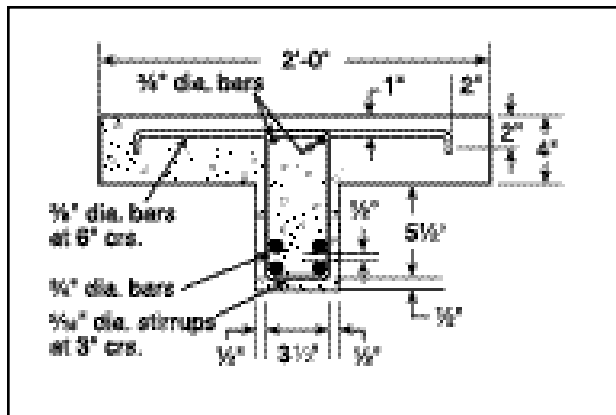

Note 9, Table 4.1.1

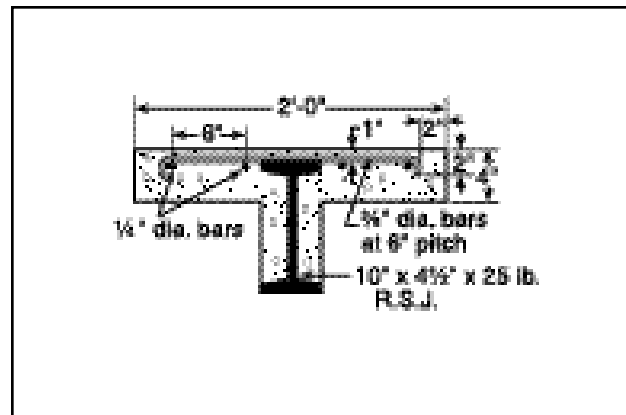

Note 12, Table 4.1.1

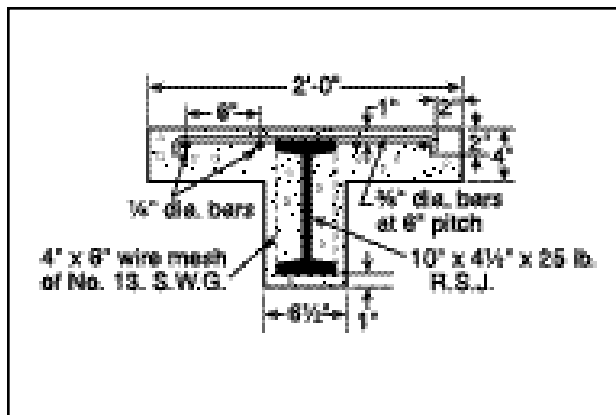

Note 10, Table 4.1.1

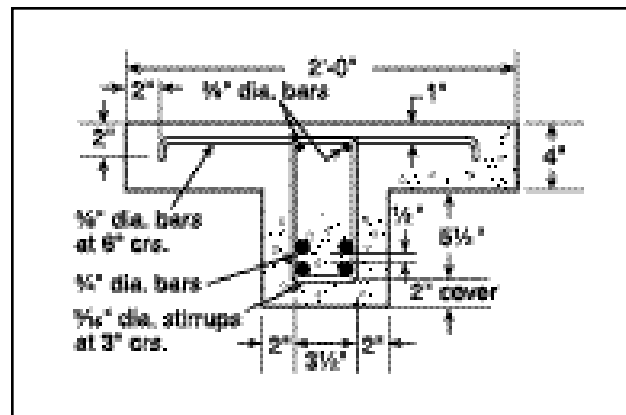

Note 13, Table 4.1.1

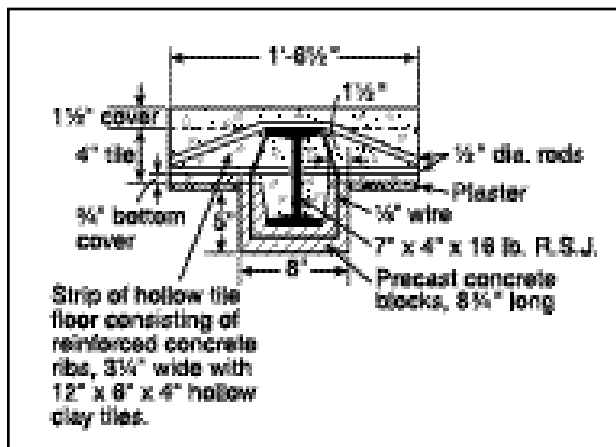

Note 11, Table 4.1.1

Table 4.1.2
Reinforced Concrete Beams
Depth 12" (300 mm) to less than 14" (350 mm)

Item Code	Depth	Construction Details	Performance		Reference Number			Notes	Rec Hours
			Load	Time	Pre BMS 92	BMS	Post-BMS 92		
B-12-RC-1	12"	12" x 8" section; 4160 psi aggregate concrete; reinforcing 4—7/8" rebars at corners; 1" below each surface; 1/4" stirrups 10" O.C.	5.5 tons	2 hrs	-	-	7	1	2
B-12-RC-2	12"	Concrete flange: 4" deep x 2' wide (3045 psi) @ 35 days; concrete beam: 8" deep; I beam reinforcement: 10" x 4 1/2" x 25 lb R.S.J.; 1" cover on flanges; reinforcement: flange 3/8" diam. bars @ 6" pitch parallel to T; flange 1/4" diam. bars perpendicular to T; beam 4" x 6" wire mesh #13 S.W.G.; span: 10'3" simply supported	10 tons	4 hrs	-	-	7	2,3,5	4
B-13-RC-3	13"	Concrete flange: 4" deep x 2' wide; (3825 psi) @ 46 days; concrete beam: 9" deep x 8 1/2" wide (scaled from dwg.); I beam reinforcement: 10" x 4 1/2" x 25 lb R.S.J.; 3" cover on bottom flange 1" cover on top flange; reinforcement: flange 3/8" diam. bars @ 6" pitch, parallel to T; 1/4" diam. bars perpendicular to T; beam 4" x 6" wire mesh #13 S.W.G.; span 11' restrained	10 tons	6 hrs	-	-	7	2,3,6,8,9	4
B-13-RC-4	12"	Concrete flange: 4" deep x 2' wide; (3720 psi) @ 42 days; concrete beam: 8" deep x 8 1/2" wide (scaled fr. dwg.) I beam reinforcement: 10" x 4 1/2" x 25 lb R.S.J.; 2" cover bottom flange; 1" cover top flange; reinforcement: flange 3/8" diam. bars @ 6" pitch parallel to T; 1/4" diam. bars perpendicular to T; beam: 4" x 6" wire mesh, #13 S.W.G.; span: 11' restrained	10 tons	6 hrs	-	-	7	2-4,7-9	4

Table 4.1.2—Notes

Reinforced Concrete Beams, depth 12" to less than 14"

1. Qualified for 2-hr use. (Grade "C"—British) test included hose stream and reload at 48 hours.
2. Load concentrated at mid-span.
3. British test.
4. British test—qualified for 6-hr use (Grade "A").
5. See figure below.
6. See figure below.
7. See figure below.
8. See Table 4.1.3, Note 5.
9. Hourly rating based upon B-12-RC-2.

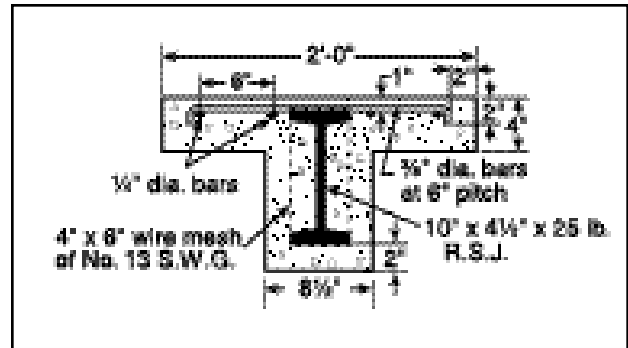

Note 7, Table 4.1.2

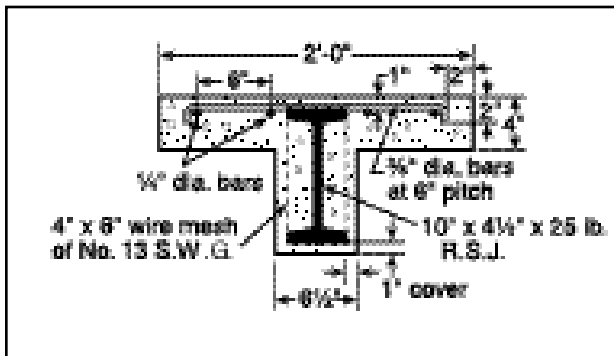

Note 5, Table 4.1.2

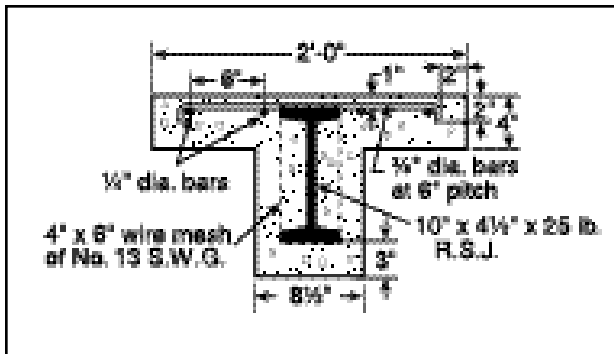

Note 6, Table 4.1.2

Table 4.1.3
Reinforced Concrete Beams
Depth 14" (350 mm) to less than 16" (400 mm)

Item Code	Depth	Construction Details	Performance		Reference Number			Notes	Rec Hours
			Load	Time	Pre BMS 92	BMS	Post-BMS 92		
B-15-RC-1	15"	Concrete flange: 4" deep x 2' wide (3290 psi) concrete; concrete beam: 10" deep x 8 1/2" wide; I beam reinforcement: 10" x 4 1/2" x 25 lb R.S.J.; 4" cover on bottom flange; 1" cover on top reinforcement: flange; 3/8" diam. bars @ 6" pitch parallel to T; 1/4" diam. bars perpendicular to T; beam 4" x 6" wire mesh No. 13 S.W.G.; span: 11' restrained	10 tons	6 hrs	-	-	7	1,2,3,5,6	4
B-15-RC-2	15"	Concrete flange: 4" deep x 2' wide (4820 psi) concrete; concrete beams: 10" deep x 8 1/2" wide; I beam reinforcement: 10" x 4 1/2" x 25 lb R.S.J.; 1" cover on top flange; 1" cover over wire mesh on bottom reinforcement: flange; 3/8" diam. bars @ 6" pitch parallel to T; 1/4" diam. bars perpendicular to T; beam 4" x 6" wire mesh No. 13 S.W.G.; span 11' restrained	10 tons	6 hrs	-	-	7	1,2,4,5,6	4

Table 4.1.3—Notes
Reinforced Concrete Beams, depth 14" to less than 16"

1. Load concentrated at mid-span.
2. Achieved 6-hr fire rating (Class "A"—British).
3. See Figure.
4. See Figure.
5. Section 43.147 of the 1979 Edition of the Uniform Building Code Standards provides:

"Restrained condition in fire tests, as used in this standard, is one in which expansion at the supports of a load-carrying element resulting from the effects of the fire is resisted by forces external to the element. An unrestrained condition is one in which the load-carrying element is free to expand and rotate at its support.

"(R)estraint in buildings is defined as follows: Floor and roof assemblies and individual beams in buildings shall be considered restrained when the surrounding or supporting structure is capable of resisting the thermal expansion throughout the range of anticipated elevated temperatures. Construction not complying...is assumed to be free to rotate and expand and shall be considered unrestrained.

"Restrainer may be provided by the lateral stiffness of supports for floor and roof assemblies and intermediate beams forming part of the assembly. In order to develop restraint, connections must adequately transfer thermal thrusts to such supports. The rigidity of adjoining panels or structures shall be considered in assessing the capabilities of a structure to resist thermal expansion."

Because it is difficult to determine whether an existing building's structural system is capable of providing the required restraint, the lower hourly ratings of a similar, but unrestrained assembly have been recommended.

6. Hourly rating based upon Table 4.1.2, Item B-12-RC-2.

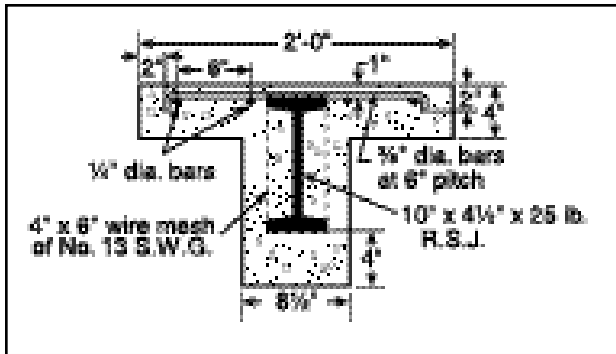

Note 3, Table 4.1.3

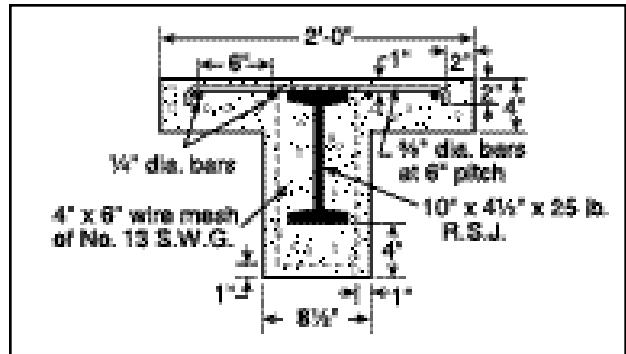

Note 4, Table 4.1.3

Table 4.2.1
Reinforced Concrete Beams—Unprotected
Depth 10" (250 mm) to less than 12" (300 mm)

Item Code	Depth	Construction Details	Performance		Reference Number			Notes	Rec Hours
			Load	Time	Pre BMS	BMS	Post-BMS		
B-SU-1	10"	10" x 4 1/2" x 25 lb I beam	10 tons	39 min	-	-	7	1	1/3

Table 4.2.1—Notes

Reinforced Concrete Beams—Unprotected, depth 10" to less than 12"

1. Concentrated at mid-span.

Table 4.2.2
Steel Beams—Concrete Protection
Depth 10" (250 mm) to less than 12" (300 mm)

Item Code	Depth	Construction Details	Performance		Reference Number			Notes	Rec Hours
			Load	Time	Pre BMS 92	BMS	Post-BMS 92		
B-SC-1	10"	10" x 8" rectangle; aggregate concrete (4170 psi) with 1" cover top and 2" cover bottom; No. 13 S.W.G. iron wire loosely wrapped at approximately 6" pitch about 7" x 4" x 16 lb I beam	3.9 tons	3 hrs 46 min	-	-	7	1,2,3	3 3/4
B-SC-2	10"	10" x 8" rectangle; aggregate concrete (3630 psi) with 1" cover top and 2" cover bottom; No. 13 S.W.G. iron wire loosely wrapped at approximately 6" pitch about 7" x 4" x 16 lb I beam	5.5 tons	5 hrs 26 min	-	-	7	1,4,5,6,7	3 3/4

Table 4.2.2—Notes

Steel Beams—Concrete Protection, depth 10" to less than 12"

1. Load concentrated at mid-span.
2. Specimen 10'3" clear span simply supported.
3. Passed Grade "C" fire resistance (British) including hose stream and reload.
4. Specimen 11' clear span—restrained.
5. Passed Grade "B" fire resistance (British) including hose stream and reload.
6. See Table 4.1.3, Note 5.
7. Hourly rating based upon B-SC-1 above.

SECTION V—DOORS

Figure 5.1
Resistance of Doors to Fire Exposure

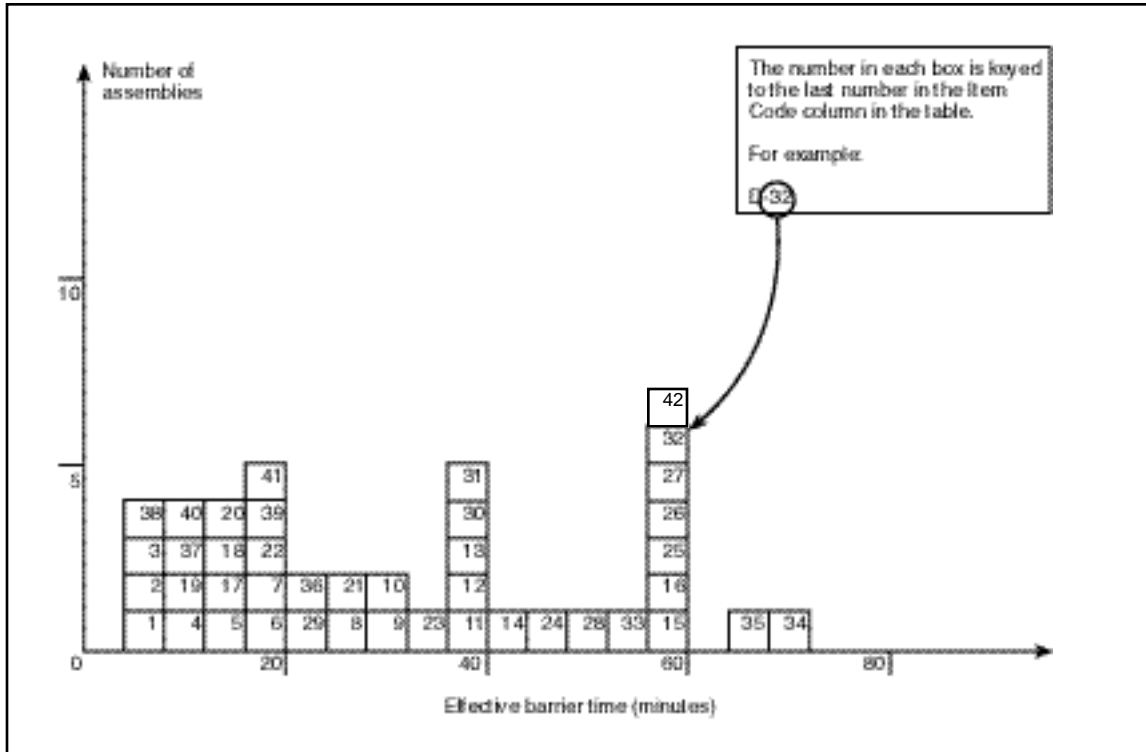

Table 5.1
Resistance of Doors to Fire Exposure

Item Code	Door Min. Thickness	Construction Details	Performance		Reference Number			Notes	Rec (Min.)
			Effective Barriers	Edge Flaming	Pre BMS 92	BMS	Post-BMS 92		
D-1	3/8"	Panel door, pine perimeter (1 3/8"); painted (enamel)	5 min 10 sec	n/a	-	-	90	1,2	5
D-2	3/8"	As above, with 2 coats U.L. listed intumescent coating	5 min 30 sec	5 min	-	-	90	1,2,7	5
D-3	3/8"	As D-1 with standard primer and flat interior paint	5 min 55 sec	n/a	-	-	90	1,3,4	5
D-4	2 5/8"	As D-1 with panels covered each side with 1/2" plywood, edge grouted with sawdust filled plaster; door faced with 1/8" hardboard each side; paint see (5)	11 min 15 sec	3 min 45 sec	-	-	90	1,2,5,7	10
D-5	3/8"	As D-1 but surface protected with glass fiber reinforced intumescent fire retardant coating	16 min	n/a	-	-	90	1,3,4,7	15

Table 5.1, continued (Resistance of Doors to Fire Exposure)

Item Code	Door Min. Thickness	Construction Details	Performance		Reference Number			Notes	Rec (Min.)
			Effective Barriers	Edge Flaming	Pre BMS 92	BMS	Post-BMS 92		
D-5	3/8"	As D-1 but surface protected with glass fiber reinforced intumescent fire retardant coating	16 min	n/a	-	-	90	1,3,4,7	15
D-6	1 5/8"	Door detail as D-4 but with 1/8" cement asbestos board facings with aluminum foil; door edges protected by sheet metal	17 min	10 min 5 sec	-	-	90	1,3,4	15
D-7	1 5/8"	Door detail with 1/8" hardboard cover each side as facings; glass fiber reinforced intumescent coating applied	20 min	n/a	-	-	90	1,3,4,7	20
D-8	1 5/8"	Door detail as D-4; panel was glass reinforced epoxy intumescent	26 min	24 min 45 sec	-	-	90	1,3,4,6,7	25
D-9	1 5/8"	Door detail as D-4 with facings of 1/8" cement asbestos board	29 min	3 min 15 sec	-	-	90	1,2	5
D-10	1 5/8"	As per D-9	31 min 30 sec	7 min 20 sec	-	-	90	1,3,4	6
D-11	1 5/8"	As per D-7 painted with epoxy intumescent coating including glass fiber roving	36 min 25 sec	n/a	-	-	90	1,3,4	35
D-12	1 5/8"	As per D-4 with intumescent fire retardant paint	37 min 30 sec	24 min 40 sec	-	-	90	1,3,4	30
D-13	1 1/2" (nom.)	As per D-4 but with 24 ga. galv. sheet metal facings	39 min	39 min	-	-	90	1,3,4	39
D-14	1 5/8"	As per D-9	41 min 30 sec	17 min 20 sec	-	-	90	1,3,4,6	20
D-15	-	Class C steel fire door	60 min	58 min	-	-	90	7,8	60
D-16	-	Class B steel fire door	60 min	57 min	-	-	90	7,8	60
D-17	1 3/4"	Solid core flush door; core staves laminated to facings but not each other; birch plywood facings 1/2" rebate in door frame for door; 3/32" clearance between door and wood frame	15 min	13 min	-	-	37	11	13
D-18	1 3/4"	As per D-17	14 min	13 min	-	-	37	11	13
D-19	1 3/4"	Door as per D-17 but with 16 ga. steel; 3/32" door frame clearance	12 min	-	-	-	37	9,11	10
D-20	1 3/4"	As per D-19	16 min	-	-	-	37	10,11	10
D-21	1 3/4"	Door as per D-17 intumescent paint applied to top and side edges	26 min	-	-	-	37	11	25
D-22	1 3/4"	Door as per D-17 but with 1/2" x 1/8" steel strip set into edges of door at top and side facing stops; matching strip on stop	18 min	6 min	-	-	37	11	18

Table 5.1, continued (Resistance of Doors to Fire Exposure)

Item Code	Door Min. Thickness	Construction Details	Performance		Reference Number			Notes	Rec (Min.)
			Effective Barriers	Edge Flaming	Pre BMS 92	BMS	Post-BMS 92		
D-23	1 3/4"	Solid oak door	36 min	22 min	-	-	15	13	25
D-24	1 5/8"	Solid oak door	45 min	35 min	-	-	15	13	35
D-25	1 7/8"	Solid teak door	58 min	34 min	-	-	15	13	35
D-26	1 7/8"	Solid (pitch) pine door	57 min	36 min	-	-	15	13	35
D-27	1 7/8"	Solid deal (pine) door	57 min	30 min	-	-	15	13	30
D-28	1 7/8"	Solid mahogany door	49 min	40 min	-	-	15	13	45
D-29	1 7/8"	Solid poplar door	24 min	3 min	-	-	15	13,14	5
D-30	1 7/8"	Solid oak door	40 min	33 min	-	-	15	13	35
D-31	1 7/8"	Solid walnut door	40 min	15 min	-	-	15	13	20
D-32	2 5/8"	Solid Quebec pine door	60 min	60 min	-	-	15	13	60
D-33	2 5/8"	Solid pine door	55 min	39 min	-	-	15	13	40
D-34	2 5/8"	Solid oak door	69 min	60 min	-	-	15	13	60
D-35	2 5/8"	Solid teak door	65 min	17 min	-	-	15	13	60
D-36	1 1/2"	Solid softwood door	23 min	8 1/2 min	-	-	15	13	10
D-37	3/4"	Panel door	8 min	7 1/2 min	-	-	15	13	5
D-38	5/16"	Panel door	5 min	5 min	-	-	15	13	5
D-39	3/4"	Panel door fire retardant treated	17 1/2 min	13 min	-	-	15	13	8
D-40	3/4"	Panel door fire retardant treated	8 1/2 min	8 1/2 min	-	-	15	13	8
D-41	3/4"	Panel door fire retardant treated	16 3/4 min	11 1/2 min	-	-	15	13	8
D-42	1 5/8"	Wood frame single lite door with sidelites and transom; includes proprietary fire resistant glazing	66 min	-	-	-	167	-	66

Table 5.1—Notes
Resistance of Doors to Fire Exposure

1. All door frames were of standard lumber construction.
2. Wood door stop protected by asbestos millboard.
3. Wood door stop protected by sheet metal.
4. Door frame protected with sheet metal and weather strip.
5. Surface painted with intumescent coating.
6. Door edge sheet metal protected.
7. Door edge intumescent paint protected.
8. Formal steel frame and door stop.
9. Door opened into furnace at 12'.
10. Similar door opened into furnace at 12'.

11. The doors reported in these tests represent the type contemporaries used as 20-minute solid core wood doors. The test results demonstrate the necessity of having wall anchored metal frames, minimum cleaners possible between door, frame, and stops. They also indicate the utility of long throw latches and the possible use of intumescent paints to seal doors to frames in event of a fire.
12. Minimum working clearance and good latch closure are absolute necessities for effective containment for all such working door assemblies.
13. Based on British tests.
14. Failure at door-frame interface.



Appendix B—Upgrading the Fire Resistance of Wood Panel Doors

This Appendix contains information from pages 28–34 of the English Heritage Technical Guidance Note, *Timber Paneled Doors and Fire*, on upgrading the fire resistance of wood panel doors (166). Twenty-eight panel door treatments are shown and the fire resistance ("result") of each is stated in **minutes**.

The fire resistance data is based on tests performed in accordance with British Standard 476, *Fire Tests on Building Materials and Structures*. The actual fire resistance of each door treatment will vary with the door's condition, the quality of its construction, and the hardware used. See Section 2.3 for additional information.

Test reference notations are composed of the initials of the test sponsor, the initials of the testing house, the test number, and the test date, such as EH/WFRC 55983 7/4/92, where:

EH	English Heritage
GLC	Greater London Council
HRPA	Historic Royal Palaces Agency
FRS	Fire Research Station
FITO	Fire Insurers Test Organisation
TRADA	Timber Research and Development Association
WFRC	Warrington Fire Research Center

Dimensions are shown in millimeters, where 1/8" = 3.2 mm, 1/4" = 6.4 mm, 3/8" = 9.5 mm, 1/2" = 12.7 mm, 5/8" = 15.9 mm, 3/4" = 19.0 mm, 7/8" = 22.2 mm, and 1" = 25.4 mm. Since 0.1 mm equals only 1/254 of an inch, conversions may be rounded to the nearest millimeter (1/25.4 of an inch).

This material is used with the permission of English Heritage, 23 Savile Row, London W1X 1AB, www.english_heritage.org.

Summary of fire test results
 All doors constructed from softwood unless otherwise stated

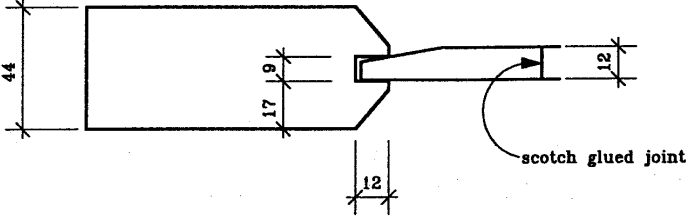
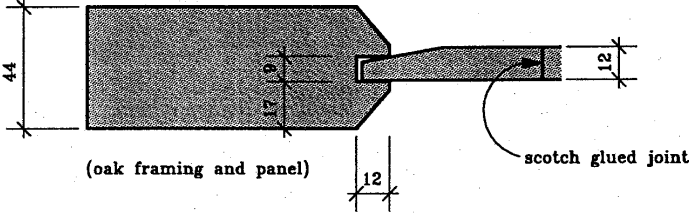
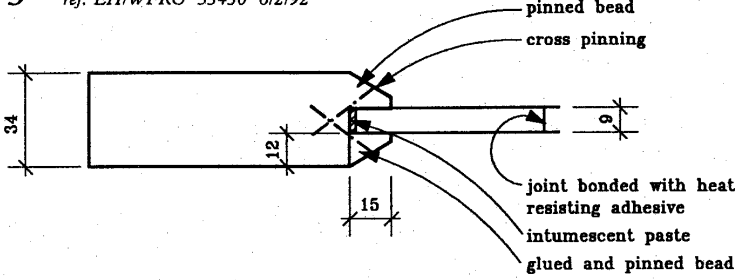
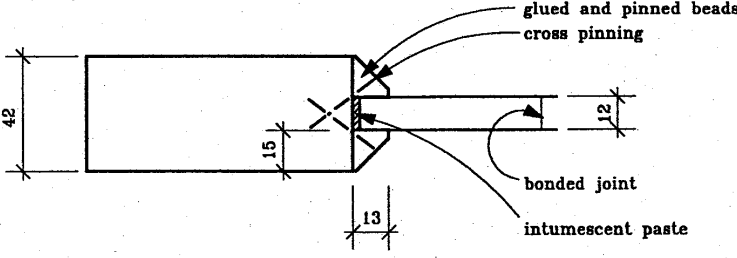
	<i>face exposed to fire</i>	Result <i>(minutes)</i>
<p>1 ref: GLC/FRS 30/6/80</p>  <p>scotch glued joint</p>	<p>11 Location of failure: panel joint</p>	
<p>2 ref: GLC/FRS 30/6/80</p>  <p>(oak framing and panel)</p> <p>scotch glued joint</p>	<p>9 Location of failure: panel joint</p>	
<p>3 ref: EH/WFRC 53430 6/2/92</p>  <p>pinned bead cross pinning joint bonded with heat resisting adhesive intumescent paste glued and pinned bead</p>	<p>15 Location of failure: burn through panel</p>	
<p>4 ref: EH/WFRC 55983 7/4/92</p>  <p>glued and pinned beads cross pinning bonded joint intumescent paste</p>	<p>20 Location of failure: panel/framing joint</p>	

Summary of fire test results (continued)

All doors constructed from softwood unless otherwise stated

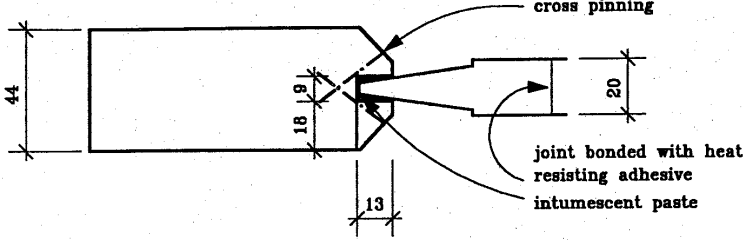
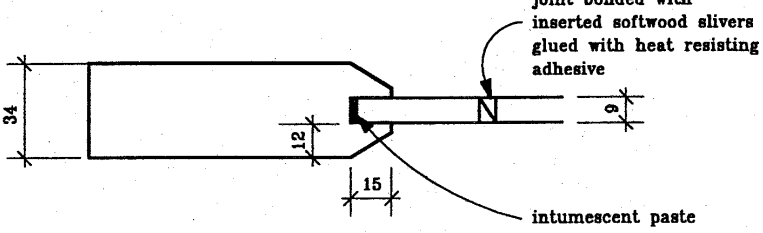
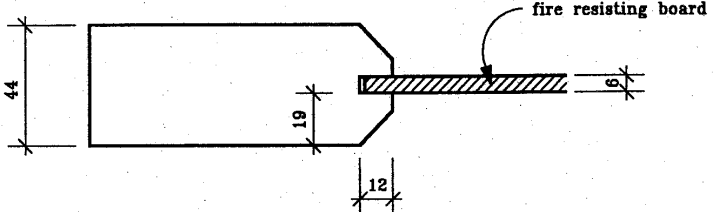
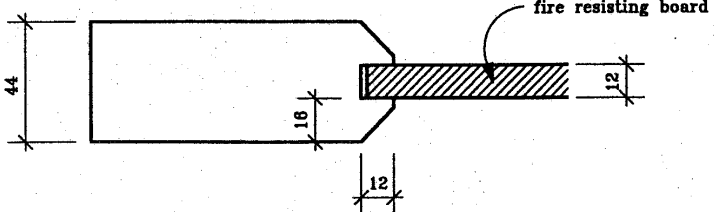
	<i>face exposed to fire</i>	Result (minutes)
<p>5 ref: EHI/WFRC 48927 6/6/90</p>  <p>Diagram 5 shows a door joint with a panel width of 44. The joint is 18 units wide and 13 units high. It features cross pinning and is bonded with heat-resisting adhesive and intumescent paste. The door is 20 units thick.</p>	<p>24 Location of failure: panel /framing joint</p>	
<p>6 ref: EHI/WFRC 53430 6/2/90</p>  <p>Diagram 6 shows a door joint with a panel width of 34. The joint is 12 units wide and 15 units high. It is bonded with inserted softwood slivers and heat-resisting adhesive, and includes intumescent paste. The door is 9 units thick.</p>	<p>6 Location of failure: panel joint</p>	
<p>7 ref: GLC/FRS 2/7/80</p>  <p>Diagram 7 shows a door joint with a panel width of 44. The joint is 19 units wide and 12 units high. It features a fire-resisting board. The door is 6 units thick.</p>	<p>16.5 Location of failure: panel/framing joint</p>	
<p>8 ref: GLC/FRS 2/7/80</p>  <p>Diagram 8 shows a door joint with a panel width of 44. The joint is 16 units wide and 12 units high. It features a fire-resisting board. The door is 12 units thick.</p>	<p>13 Location of failure: panel/framing joint</p>	

Summary of fire test results (continued)

All doors constructed from softwood unless otherwise stated

	<i>face exposed to fire</i>	<i>Result (minutes)</i>
<p>9 ref: EHI/WFRC 53462 6/4/92</p> <p>glued and pinned bead cross pinning fire resisting board intumescent paste</p> <p>34 14 15 6</p>	<p>29</p>	
<p>10 ref: GLC/FIRTO 20/10/78</p> <p>plasterboard chamfered and pinned fire resisting board plywood panel plasterboard</p> <p>38 16 16 6 9 6</p>	<p>28 Location of failure: door leaf/frame junction</p>	
<p>11 ref: -TRADA D9A 4/87</p> <p>cross pinning intumescent paste fire resisting board</p> <p>(hardwood framing and panel)</p> <p>43 12 12 6</p>	<p>30</p>	
<p>12 ref: -TRADA D9A 4/87</p> <p>cross pinning intumescent paste fire resisting board</p> <p>(hardwood framing and panel)</p> <p>43 12 12 6</p>	<p>21</p>	

Summary of fire test results (continued)
 All doors constructed from softwood unless otherwise stated

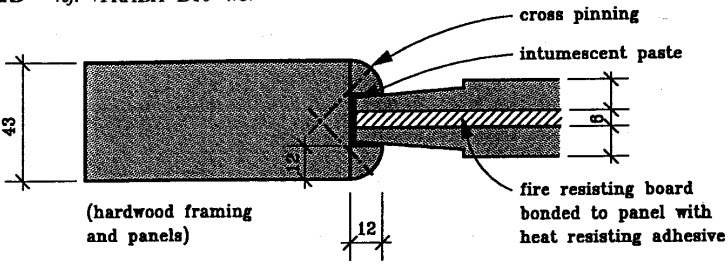
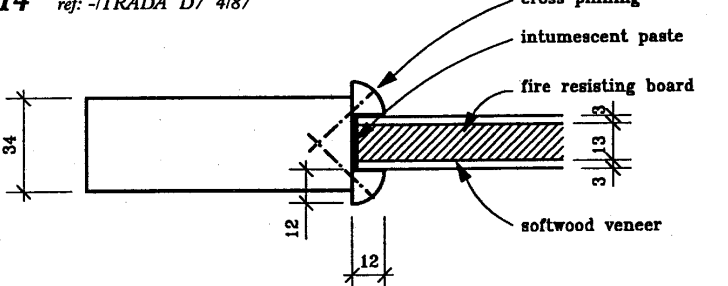
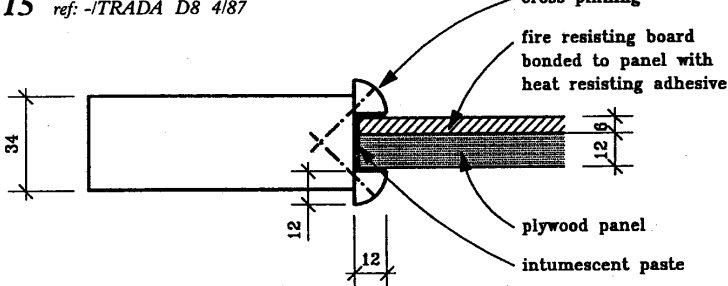
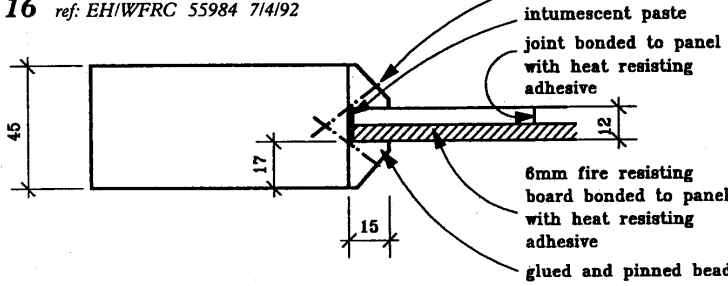
	<i>face exposed to fire</i>	<i>Result (minutes)</i>
<p>13 ref: -/TRADA D10 4/87</p>  <p>(hardwood framing and panels)</p> <p>cross pinning</p> <p>intumescent paste</p> <p>fire resisting board bonded to panel with heat resisting adhesive</p>	<p>30</p>	
<p>14 ref: -/TRADA D7 4/87</p>  <p>cross pinning</p> <p>intumescent paste</p> <p>fire resisting board</p> <p>softwood veneer</p>	<p>30</p>	
<p>15 ref: -/TRADA D8 4/87</p>  <p>cross pinning</p> <p>fire resisting board bonded to panel with heat resisting adhesive</p> <p>plywood panel</p> <p>intumescent paste</p>	<p>30</p>	
<p>16 ref: EH/WFRC 55984 7/4/92</p>  <p>cross pinning</p> <p>intumescent paste</p> <p>joint bonded to panel with heat resisting adhesive</p> <p>6mm fire resisting board bonded to panel with heat resisting adhesive</p> <p>glued and pinned beads</p>	<p>30+</p>	

Summary of fire test results (continued)
 All doors constructed from softwood unless otherwise stated

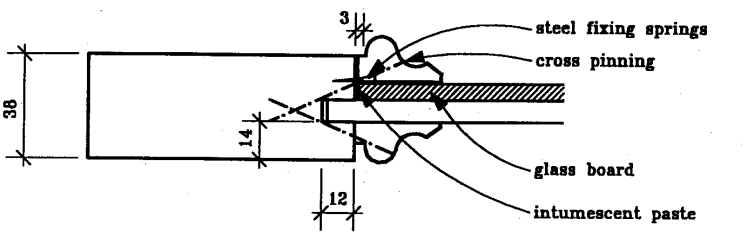
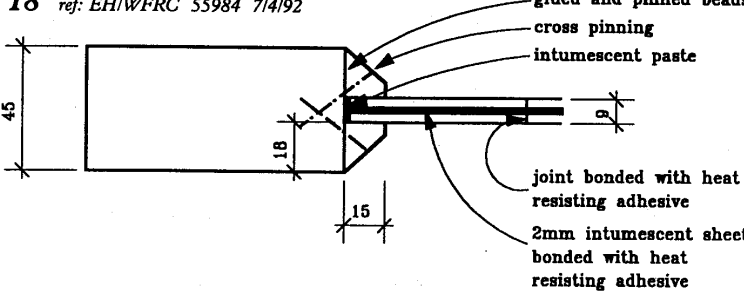
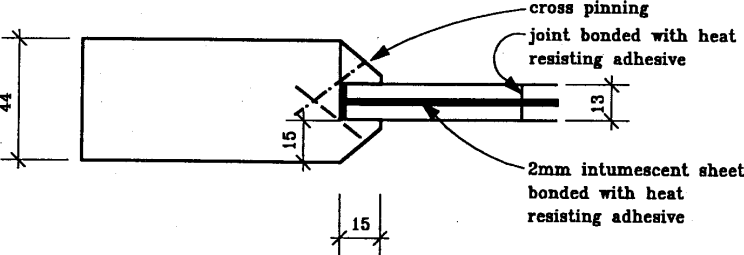
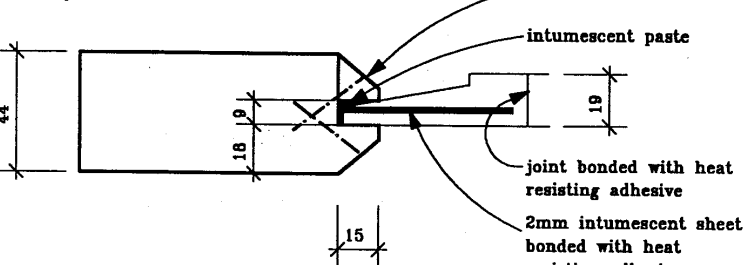
	<i>face exposed to fire</i>	<i>Result (minutes)</i>
<p>17 ref: EHI/WFRC 60184 25/10/93</p>  <p>steel fixing springs cross pinning glass board intumescent paste</p>	<p>27 Location of failure: panel/framing joint</p>	
<p>18 ref: EHI/WFRC 55984 7/4/92</p>  <p>glued and pinned beads cross pinning intumescent paste joint bonded with heat resisting adhesive 2mm intumescent sheet bonded with heat resisting adhesive</p>	<p>23 Location of failure: burn through panel</p>	
<p>19 ref: EHI/WFRC 48926 6/6/90</p>  <p>cross pinning joint bonded with heat resisting adhesive 2mm intumescent sheet bonded with heat resisting adhesive</p>	<p>30+</p>	
<p>20 ref: EHI/WFRC 48926 6/6/90</p>  <p>cross pinning intumescent paste joint bonded with heat resisting adhesive 2mm intumescent sheet bonded with heat resisting adhesive</p>	<p>30+</p>	

Summary of fire test results (continued)

All doors constructed from softwood unless otherwise stated

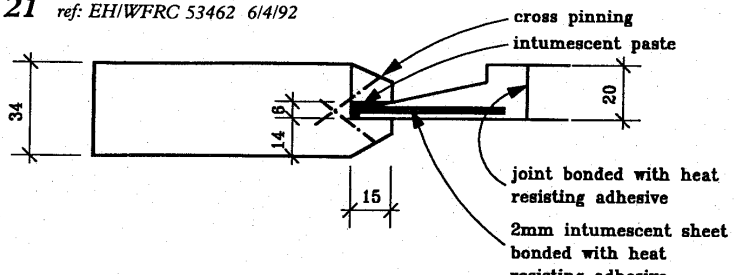
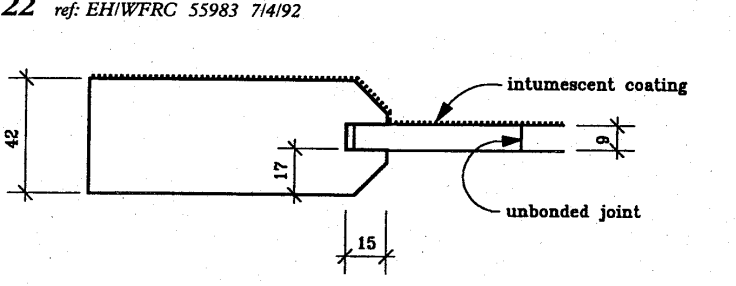
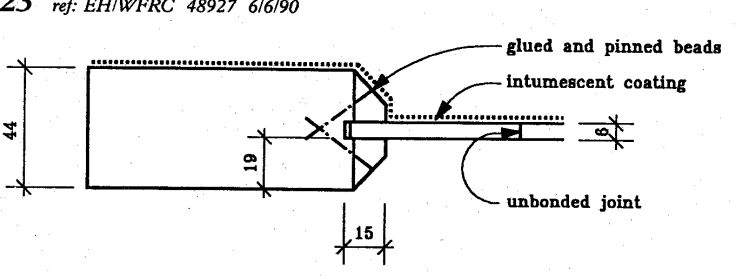
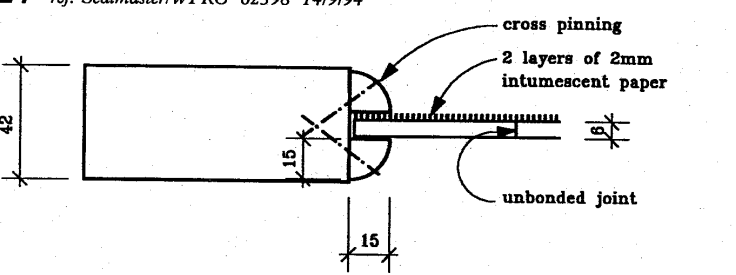
	<i>face exposed to fire</i>	<i>Result (minutes)</i>
<p>21 ref: EHI/WFRC 53462 6/4/92</p>  <p>cross pinning intumescent paste joint bonded with heat resisting adhesive 2mm intumescent sheet bonded with heat resisting adhesive</p>	<p>29.5 Location of failure: burn through panel</p>	
<p>22 ref: EHI/WFRC 55983 7/4/92</p>  <p>intumescent coating unbonded joint</p>	<p>11 Location of failure: panel joint</p>	
<p>23 ref: EHI/WFRC 48927 6/6/90</p>  <p>glued and pinned beads intumescent coating unbonded joint</p>	<p>17 Location of failure: panel/frame joint</p>	
<p>24 ref: Sealmaster/WFRC 62398 14/9/94</p>  <p>cross pinning 2 layers of 2mm intumescent paper unbonded joint</p>	<p>30+</p>	

Summary of fire test results (continued)
 All doors constructed from softwood unless otherwise stated

	<i>face exposed to fire</i>	<i>Result (minutes)</i>
<p>25 ref: Sealmaster/WFRC 62398 14/9/94</p> <p>Labels: cross pinning, intumescent paper, unbonded joint</p>	30	
<p>26 ref: HRP/ITRADA FR 95082 9/9/95</p> <p>Labels: cross pinning, intumescent paper with plywood veneer face</p>	30	
<p>27 ref: - TRADA D5 4/87</p> <p>Labels: plain glass, 6mm georgian wired glass, 2mm intumescent strip</p>	30	
<p>28 ref: - TRADA D6 4/87</p> <p>Labels: intumescent strip, intumescent varnish, 6mm georgian wired glass</p>	30	

Appendix C—Bibliography

1. Central Housing Committee on Research, Design, and Construction; Subcommittee on Fire Resistance Classifications, "Fire-Resistance Classifications of Building Constructions," *Building Materials and Structures*, Report BMS 92, National Bureau of Standards, Washington, Oct. 1942. (Available from NTIS No. COM-73-10974)
2. Foster, H. D., Pinkston, E. R., and Ingberg, S. H., "Fire Resistance of Structural Clay Tile Partitions," *Building Materials and Structures*, Report BMS 113, National Bureau of Standards, Washington, Oct. 1948.
3. Ryan, J. V., and Bender, E. W., "Fire Endurance of Open Web Steel-Joist Floors with Concrete Slabs and Gypsum Ceilings," *Building Materials and Structures*, Report BMS 141, National Bureau of Standards, Washington, Aug. 1954.
4. Mitchell, N. D., "Fire Tests of Wood-Framed Walls and Partitions with Asbestos-Cement Facings," *Building Materials and Structures*, Report BMS 123, National Bureau of Standards, Washington, May 1951.
5. Robinson, H. E., Cosgrove, L.A., and Powell, F. J., "Thermal Resistance of Airspace and Fibrous Insulations Bounded by Reflective Surfaces," *Building Materials and Structures*, Report BMS 151, National Bureau of Standards, Washington, Nov. 1957.
6. Shoub, H., and Ingberg, S. H., "Fire Resistance of Steel Deck Floor Assemblies," *Building Science Series*, 11, National Bureau of Standards, Washington, Dec. 1967.
7. Davey, N., and Ashton, L. A., "Investigations on Building Fires, Part V: Fire Tests of Structural Elements," *National Building Studies*, Research Paper, No. 12, Dept. of Scientific and Industrial Research (Building Research Station), London, 1953.
8. National Board of Fire Underwriters, *Fire Resistance Ratings of Beam, Girder, and Truss Protections, Ceiling Constructions, Column Protections, Floor and Ceiling Constructions, Roof Constructions, Walls and Partitions*, New York, April 1959.
9. Mitchell, N. D., Bender, E. D., and Ryan, J. V., "Fire Resistance of Shutters for Moving-Stairway Openings," *Building Materials and Structures*, Report BMS 129, National Bureau of Standards, Washington, March 1952.
10. National Board of Fire Underwriters, *National Building Code: An Ordinance Providing for Fire Limits, and Regulations Governing the Construction, Alteration, Equipment, or Removal of Buildings or Structures*, New York, 1949.
11. Department of Scientific and Industrial Research and of the Fire Offices' Committee, Joint Committee of the Building Research Board, "Fire Gradings of Buildings, Part I. General Principles and Structural Precautions," *Post-War Building Studies*, No. 20, Ministry of Works, London, 1946.
12. Lawson, D. I., Webster, C. T., and Ashton, L. A., "Fire Endurance—of Timber Beams and Floors," *National Building Studies*, Bulletin, No. 13, Dept. of Scientific and Industrial Research and Fire Offices' Committee (Joint Fire Research Organization), London, 1951.
13. Parker, T. W., Nurse, R. W., and Bessey, G. E., "Investigations on Building Fires, Part I: The Estimation of the Maximum Temperature Attained in Building Fires from Examination of the Debris, and Part II: The Visible Change in Concrete or Mortar Exposed to High Temperatures," *National Building Studies*, Technical Paper, No. 4, Dept. of Scientific and Industrial Research (Building Research Station), London, 1950.
14. Bevan, R. C., and Webster, C. T., "Investigations on Building Fires, Part III: Radiation from Building Fires," *National Building*

- Studies*, Technical Paper, No. 5, Dept. of Scientific and Industrial Research (Building Research Station), London, 1950.
15. Webster, D. J., and Ashton, L. A., "Investigations on Building Fires, Part IV: Fire Resistance of Timber Doors," *National Building Studies*, Technical Paper, No. 6, Dept. of Scientific and Industrial Research (Building Research Station), London, 1951.
16. Kidder, F. E., *Architects' and Builders' Handbook: Data for Architects, Structural Engineers, Contractors, and Draughtsmen*, comp. by a Staff of Specialists and H. Parker, editor-in-chief, 18th ed., enl., J. Wiley, New York, 1936.
17. Parker, H., Gay, C. M., and MacGuire, J. W., *Materials and Methods of Architectural Construction*, 3rd ed., J. Wiley, New York, 1958.
18. Dietz, A. G. H., *Dwelling House Construction*, The MIT Press, Cambridge, 1971.
19. Crosby, E. U., and Fiske, H. A., *Handbook of Fire Protection*, 5th ed., The Insurance Field Company, Louisville, Ky., 1914.
20. Crosby, E. U., Fiske, H. A., and Forster, H. W., *Handbook of Fire Protection*, 8th ed., R. S. Moulton, general editor, National Fire Protection Association, Boston, 1936.
21. Kidder, F. E., *Building Construction and Superintendence*, rev. and enl., by T. Nolan, W. T. Comstock, New York, 1909–1913, 2 vols.
22. National Fire Protection Association, Committee on Fire Resistive Construction, *The Baltimore Conflagration*, 2nd ed., Chicago, 1904.
23. Przetak, L., *Standard Details for Fire-Resistive Building Construction*, McGraw-Hill Book Co., New York, 1977.
24. Hird, D., and Fischl, C. F., "Fire Hazard of Internal Linings," *National Building Studies*, Special Report, No. 22, Dept. of Scientific and Industrial Research and Fire Offices' Committee (Joint Fire Research Organization), London, 1954.
25. Menzel, C. A., *Tests of the Fire-Resistance and Strength of Walls Concrete Masonry Units*, Portland Cement Association, Chicago, 1934.
26. Hamilton, S. B., "A Short History of the Structural Fire Protection of Buildings Particularly in England," *National Building Studies*, Special Report, No. 27, Dept. of Scientific and Industrial Research (Building Research Station), London, 1958.
27. Sachs, E. O., and Marsland, E., "The Fire Resistance of Doors and Shutters being Tabulated: Results of Fire Tests Conducted by the Committee," *Journal of the British Fire Prevention Committee*, No. VII, London, 1912.
28. Egan, M. D., *Concepts in Building Firesafety*, J. Wiley, New York, 1978.
29. Sachs, E. O., and Marsland, E., "The Fire Resistance of Floors being Tabulated: Results of Fire Tests Conducted by the Committee," *Journal of the British Fire Prevention Committee*, No. VI, London, 1911.
30. Sachs, E. O., and Marsland, E., "The Fire Resistance of Partitions being Tabulated: Results of Fire Tests Conducted by the Committee," *Journal of the British Fire Prevention Committee*, No. IX, London, 1914.
31. Ryan, J. V., and Bender, E. W., "Fire Tests of Precast Cellular Concrete Floors and Roofs," *National Bureau of Standards Monograph*, 45, Washington, April 1962.
32. Kingberg, S. H., and Foster, H. D., "Fire Resistance of Hollow Load-Bearing Wall Tile," *National Bureau of Standards Research Paper*, No. 37, (Reprint from *NBS Journal of Research*, Vol. 2) Washington, 1929.
33. Hull, W. A., and Ingberg, S. H., "Fire Resistance of Concrete Columns," *Technologic Papers of the Bureau of Standards*, No. 272, Vol. 18, Washington, 1925, pp. 635–708.

34. National Board of Fire Underwriters, *Fire Resistance Ratings of Less than One Hour*, New York, Aug. 1956.
35. Harmathy, T. Z., "Ten Rules of Fire Endurance Rating," *Fire Technology*, Vol. 1, May 1965, pp. 93-102.
36. Son, B. C., "Fire Endurance Test on a Steel Tubular Column Protected with Gypsum Board," *National Bureau of Standards*, NBSIR, 73-165, Washington, 1973.
37. Galbreath, M., "Fire Tests of Wood Door Assemblies," *Fire Study*, No. 36, Div. of Building Research, National Research Council Canada, Ottawa, May 1975.
38. Morris, W. A., "An Investigation into the Fire Resistance of Timber Doors," *Fire Research Note*, No. 855, Fire Research Station, Boreham Wood, Jan. 1971.
39. Hall, G. S., "Fire Resistance Tests of Laminated Timber Beams," *Timber Association Research Report*, WR/RR/1, High Sycombe, July 1968.
40. Goalwin, D. S., "Fire Resistance of Concrete Floors," *Building Materials and Structures*, Report BMS 134, National Bureau of Standards, Washington, Dec. 1952.
41. Mitchell, N. D., and Ryan, J. V., "Fire Tests of Steel Columns Encased with Gypsum Lath and Plaster," *Building Materials and Structures*, Report BMS 135, National Bureau of Standards, Washington, April 1953.
42. Ingberg, S. H., "Fire Tests of Brick Walls," *Building Materials and Structures*, Report BMS 143, National Bureau of Standards, Washington, Nov. 1954.
43. National Bureau of Standards, "Fire Resistance and Sound Insulation Ratings for Walls, Partitions, and Floors," *Technical Report on Building Materials*, 44, Washington, 1946.
44. Malhotra, H. L., "Fire Resistance of Brick and Block Walls," *Fire Note*, No. 6, Ministry of Technology and Fire Offices' Committee Joint Fire Research Organization, London, HMSO, 1966.
45. Mitchell, N. D., "Fire Tests of Steel Columns Protected with Siliceous Aggregate Concrete," *Building Materials and Structures*, Report BMS 124, National Bureau of Standards, Washington, May 1951.
46. Freitag, J. K., *Fire Prevention and Fire Protection as Applied to Building Construction: A Handbook of Theory and Practice*, 2nd ed., J. Wiley, New York, 1921.
47. Ingberg, S. H., and Mitchell, N. D., "Fire Tests of Wood and Metal-Framed Partition," *Building Materials and Structures*, Report BMS 71, National Bureau of Standards, Washington, 1941.
48. Central Housing Committee on Research, Design, and Construction, Subcommittee on Definitions, "A Glossary of Housing Terms," *Building Materials and Structures*, Report BMS 91, National Bureau of Standards, Washington, Sept. 1942.
49. Crosby, E. U., Fiske, H. A., and Forster, H. W., *Handbook of Fire Protection*, 7th ed., D. Van Nostrand Co., New York 1924.
50. Bird, E. L., and Docking, S. J., *Fire in Buildings*, A. & C. Black, London, 1949.
51. American Institute of Steel Construction, *Fire Resistant Construction in Modern Steel-Framed Buildings*, New York, 1959.
52. Central Dockyard Laboratory, "Fire Retardant Paint Tests: A Critical Review," *CDL Technical Memorandum*, No. P87/73, H. M. Naval Base, Portsmouth, Dec. 1973.
53. Malhotra, H. L., "Fire Resistance of Structural Concrete Beams," *Fire Research Note*, No. 741, Fire Research Station, Borehamwood, May 1969.
54. Abrams, M. S., and Gustafiero, A. H., "Fire Tests of PokeThru Assemblies," *Research and Development Bulletin*, 1481-1, Portland Cement Association, Skokie, 1971.
55. Bullen, M. L., "A Note on the Relationship between Scale Fire Experiments and

- Standard Test Results," **Building Research Establishment Note**, N51/75, Borehamwood, May 1975.
56. The America Fore Group of Insurance Companies, Research Department, **Some Characteristic Fires in Fire Resistive Buildings**, Selected from 20 years record in the files of the N.F.P.A. "Quarterly." New York, c. 1933.
57. Spiegelhalter, F., "Guide to Design of Cavity Barriers and Fire Stops," **Current Paper**, CP 7/77, Building Research Establishment, Borehamwood, Feb. 1977.
58. Wardle, T. M. "Notes on the Fire Resistance of Heavy Timber Construction," **Information Series**, No. 53, New Zealand Forest Service, Wellington, 1966.
59. Fisher, R. W., and Smart, P. M. T., "Results of Fire Resistance Tests on Elements of Building Construction," **Building Research Establishment Report**, G R6, London, HMSO, 1975.
60. Serex, E. R., "Fire Resistance of Alta Bates Gypsum Block Non-Load Bearing Wall," Report to Alta Bates Community Hospital, **Structural Research Laboratory Report**, ES-7000, University of Calif., Berkeley, 1969.
61. Thomas, F. G., and Webster, C. T., "Investigations on Building Fires, Part VI: The Fire Resistance of Reinforced Concrete Columns," **National Building Studies**, Research Paper, No. 18, Dept. of Scientific and Industrial Research (Building Research Station), London, HMSO, 1953.
62. Building Research Establishment, "Timber Fire Doors," **Digest**, 220, Borehamwood, Nov. 1978.
63. **Massachusetts State Building Code, Recommended Provisions**, Article 22: "Repairs, Alterations, Additions, and Change of Use of Existing Buildings," Boston, Oct. 23, 1978.
64. Freitag, J. K., **Architectural Engineering; with Especial Reference to High Building Construction, Including Many Examples of Prominent Office Buildings**, 2nd ed., rewritten, J. Wiley, New York, 1906.
65. Architectural Record, **Sweet's Indexed Catalogue of Building Construction for the Year 1906**, New York, 1906.
66. Dept. of Commerce, Building Code Committee, "Recommended Minimum Requirements for Fire Resistance in Buildings," **Building and Housing**, No. 14, National Bureau of Standards, Washington, 1931.
67. British Standards Institution, "Fire Tests on Building Materials and Structures," **British Standards**, 476, Pt. 1, London, 1953.
68. Lonberg-Holm, K., "Glass," **The Architectural Record**, Oct. 1930, pp. 345-357.
69. Structural Clay Products Institute, "Fire Resistance," **Technical Notes on Brick and Tile Construction**, 16 rev., Washington, 1964.
70. Ramsey, C. G., and Sleeper, H. R., **Architectural Graphic Standards for Architects, Engineers, Decorators, Builders, and Draftsmen**, 3rd ed., J. Wiley, New York, 1941.
71. Underwriters' Laboratories, **Fire Protection Equipment List**, Chicago, Jan. 1957.
72. Underwriters' Laboratories, **Fire Resistance Director; with Hourly Ratings for Beams, Columns, Floors, Roofs, Walls, and Partitions**, Chicago, Jan. 1977.
73. Mitchell, N. D., "Fire Tests of Gunitite Slabs and Partitions," **Building Materials and Structures**, Report BMS 131, National Bureau of Standards, Washington, May 1952.
74. Woolson, I. H., and Miller, R. P., "Fire Tests of Floors in the United States," **Proceedings, International Association for Testing Materials**, VI Congress, New York, 1912, Section C, pp. 36-41.
75. Underwriters' Laboratories, "An Investigation of the Effects of Fire Exposure upon Hollow Concrete Building Units, Conducted for American Concrete Institute, Concrete Products Association, Portland Cement Association, Joint Submitters," **Retardant Report**, No. 1555, Chicago, May 1924.

76. Dept. of Scientific & Industrial Research and of the Fire Offices' Committee, Joint Committee of the Building Research Board, "Fire Gradings of Buildings, Part IV: Chimneys and Flues," *Post-War Building Studies*, No. 29, London, HMSO, 1952.
77. National Research Council of Canada. Associate Committee on the National Building Code, *Fire Performance Ratings*, Suppl. No. 2 to the National Building Code of Canada, Ottawa, 1965.
78. Associated Factory Mutual Fire Insurance Companies, The National Board of Fire Underwriters, and the Bureau of Standards, *Fire Tests of Building Columns: An Experimental Investigation of the Resistance of Columns, Loaded and Exposed to Fire or to Fire and Water, with Record of Characteristic Effects*. Jointly conducted at Underwriters' Laboratories, Chicago, 1917–19.
79. Malhotra, H. L., "Effect of Age on the Fire Resistance of Reinforced Concrete Columns," *Fire Research Memorandum*, No. 1, Fire Research Station, Borehamwood, April 1970.
80. Bond, H., ed., *Research on Fire: A Description of the Facilities, Personnel and Management of Agencies Engaged in Research on Fire*, a Staff Report, National Fire Protection Association, Boston, 1957.
81. *California State Historical Building Code*, Draft, 1978.
82. Fisher, F. L., et al., "A Study of Potential Flashover Fires in Wheeler Hall and the Results from a Full Scale Fire Test of a Modified Wheeler Hall Door Assembly," *Fire Research Laboratory Report*, UCX 77-3; UCX-2480, University of Calif., Dept. of Civil Eng., Berkeley, 1977.
83. Freitag, J. K., *The Fireproofing of Steel Buildings*, 1st ed., J. Wiley, New York, 1906.
84. Gross, D., "Field Burnout Tests of Apartment Dwellings Units," *Building Science Series*, 10, National Bureau of Standards, Washington, 1967.
85. Dunlap, M. E., and Cartwright, F. P., "Standard Fire Tests for Combustible Building Materials," *Proceedings of the American Society for Testing Materials*, vol. 27, Philadelphia, 1927, pp. 534–546.
86. Menzel, C. A., "Tests of the Fire Resistance and Stability of Walls of Concrete Masonry Units," *Proceedings of the American Society for Testing Materials*, vol. 31, Philadelphia, 1931, pp. 607–660.
87. Steiner, A. J., "Method of Fire-Hazard Classification of Building Materials," *Bulletin of the American Society for Testing and Materials*, March 1943, Philadelphia, 1943, pp. 19–22.
88. Heselden, A. J. M., Smith, P. G., and Theobald, C. R., "Fires in a Large Compartment Containing Structural Steelwork: Detailed Measurements of Fire Behavior," *Fire Research Note*, No. 646, Fire Research Station, Borehamwood, Dec. 1966.
89. Ministry of Technology and Fire Offices' Committee Joint Fire Research Organization, "Fire and Structural Use of Timber in Buildings: Proceedings of the Symposium Held at the Fire Research Station, Borehamwood, Herts, on 25th October, 1967," *Symposium*, No. 3, London, HMSO, 1970.
90. Shoub, and Gross, D., "Doors as Barriers to Fire and Smoke," *Building Science Series*, 3, National Bureau of Standards, Washington, 1966.
91. Ingberg, S. H., "The Fire Resistance of Gypsum Partitions," *Proceedings of the American Society for Testing and Materials*, vol. 25, Philadelphia, 1925, pp. 299–314.
92. Ingberg, S.H., "Influence of Mineral Composition of Aggregates on Fire Resistance of Concrete," *Proceedings of the American Society for Testing and Materials*, vol. 29, Philadelphia, 1929, pp. 824–829.
93. Ingberg, S. H., "The Fire Resistive Properties of Gypsum," *Proceedings of the American Society for Testing and Materials*, vol. 23,

- Philadelphia, 1923, pp. 254–256.
94. Gottschalk, F. W., "Some Factors in the Interpretation of Small-Scale Tests for Fire-Retardant Wood," *Bulletin of the American Society for Testing and Materials*, October 1945, pp. 40–43.
95. Ministry of Technology and Fire Offices' Committee Joint Fire Research Organization, "Behaviour of Structural Steel in Fire: Proceedings of the Symposium Held at the Fire Research Station Borehamwood, Herts, on 24th January 1967," Symposium No. 2, London, HMSO, 1968.
96. Gustaferro, A. H., and Martin, L. D., *Design for Fire Resistance of Pre-cast Concrete*, prep. for the Prestressed Concrete Institute Fire Committee, 1st ed., Chicago, PCI, 1977.
97. "The Fire Endurance of Concrete: A Special Issue," *Concrete Construction*, vol. 18, no. 8, Aug. 1974, pp. 345–440.
98. The British Constructional Steelwork Association, "Modern Fire Protection for Structural Steelwork," Publication No. FP1, London, 1961.
99. Underwriters' Laboratories, "Fire Hazard Classification of Building Materials," *Bulletin* No. 32, Sept. 1944, Chicago, 1959.
100. Central Housing Committee on Research, Design, and Construction, Subcommittee on Building Codes, "Recommended Building Code Requirements for New Dwelling Construction with Special Reference to War Housing, Report," *Building Materials and Structures*, Report BMS 88, National Bureau of Standards, Washington, Sept. 1942.
101. De Coppet Bergh, D., *Safe Building Construction: A Treatise Giving in Simplest Forms Possible Practical and Theoretical Rules and Formulae Used in Construction of Buildings and General Instruction*, new ed., thoroughly rev. Macmillan Co., New York, 1908.
102. *Cyclopedia of Fire Prevention and Insurance: a General Reference Work on Fire and Fire Losses, Fireproof Construction, Building Inspection...*, prep. by architects, engineers, underwriters and practical insurance men. American School of Correspondence, Chicago, 1912.
103. Setchkin, N. P., and Ingberg, S. H., "Test Criterion for an Incombustible Material," *Proceedings of the American Society for Testing Materials*, vol. 45, Philadelphia, 1945, pp. 866–877.
104. Underwriters' Laboratories, "Report on Fire Hazard Classification of Various Species of Lumber," *Retardant*, 3365, Chicago, 1952.
105. Steingiser, S., "A Philosophy of Fire Testing," *Journal of Fire & Flammability*, vol. 3, July 1972, pp. 238–253.
106. Yuill, C. H., Bauerschlag, W. H., and Smith, H. M., "An Evaluation of the Comparative Performance of 2.4.1 Plywood and Two-Inch Lumber Roof Decking under Equivalent Fire Exposure," *Fire Protection Section, Final Report*, Project No. 717A-3-211, Southwest Research Institute, Dept. of Structural Research, San Antonio, Dec. 1962.
107. Ashton, L. A., and Smart, P. M. T., *Sponsored Fire Resistance Tests on Structural Elements*, London, Dept. of Scientific and Industrial Research and Fire Offices' Committee, London, 1960.
108. Butcher, E. G., Chitty, T. B., and Ashton, L. A., "The Temperature Attained by Steel in Building Fires," *Fire Research—Technical Paper*, No. 15, Ministry of Technology and Fire Offices' Committee, Joint Fire Research Organization, London, HMSO, 1966.
109. Dept. of the Environment and Fire Offices' Committee, Joint Fire Research Organization, "Fire-Resistance Requirements for Buildings—A New Approach; Proceedings of the Symposium Held at the Connaught Rooms, London, 28 September 1971," *Symposium*, No. 5, London, HMSO, 1973.

110. Langdon Thomas, G. J., "Roofs and Fire," *Fire Note*, No. 3, Dept. of Scientific and Industrial Research and Fire Offices' Committee, Joint Fire Research Organization, London, HMSO, 1963.
111. National Fire Protection Association and the National Board of Fire Underwriters, *Report on Fire in the Edison Phonograph Works*, Thomas A. Edison, Inc., West Orange, N.J., December 9, 1914, Boston, 1915.
112. Thompson, J. P., *Fire Resistance of Reinforced Concrete Floors*, Portland Cement Association, Chicago, 1963.
113. Forest Products Laboratory, "Fire Resistance Tests of Plywood Covered Wall Panels," Information reviewed and reaffirmed, *Forest Service Report*, No. 1257, Madison, April 1961.
114. Forest Products Laboratory, "Charring Rate of Selected Woods—Transverse to Grain," *Forest Service Research Paper*, FLP 69, Madison, April 1967.
115. Bird, G. I., "Protection of Structural Steel Against Fire," *Fire Note*, No. 2, Dept. of Scientific and Industrial Research and Fire Offices' Committee, Joint Fire Research Organization, London, HMSO, 1961.
116. Robinson, W. C., *The Parker Building Fire*, Underwriters' Laboratories, Chicago, c. 1908.
117. Ferris, J. E., "Fire Hazards of Combustible Wallboards," *Commonwealth Experimental Building Station Special Report*, No. 18, Sydney, Oct. 1955.
118. Markwardt, L. J., Bruce, H. D., and Freas, A. D., "Brief Description of Some Fire-Test Methods Used for Wood and Wood-Based Materials," *Forest Service Report*, No. 1976, Forest Products Laboratory, Madison, 1976.
119. Foster, H. D., Pinkston, E. R., and Ingberg, S. H., "Fire Resistance of Walls of Gravel-Aggregate Concrete Masonry Units," *Building Materials and Structures*, Report, BMS 120, National Bureau of Standards, Washington, March 1951.
120. Foster, H. D., Pinkston, E.R., and Ingberg, S. H., "Fire Resistance of Walls of Light-weight-Aggregate Concrete Masonry Units," *Building Materials and Structures*, Report BMS 117, National Bureau of Standards, Washington, May 1950.
121. Structural Clay Products Institute, "Structural Clay Tile Fireproofing," *Technical Notes on Brick & Tile Construction*, vol. 1, no. 11, San Francisco, Nov. 1950.
122. Structural Clay Products Institute, "Fire Resistance Ratings of Clay Masonry Walls—I," *Technical Notes on Brick & Tile Construction*, vol. 3, no. 12, San Francisco, Dec. 1952.
123. Structural Clay Products Institute, "Estimating the Fire Resistance of Clay Masonry Walls—II," *Technical Notes on Brick & Tile Construction*, vol. 4, no. 1, San Francisco, Jan. 1953.
124. Building Research Station, "Fire: Materials and Structures," *Digest*, No. 106, London, HMSO, 1958.
125. Mitchell, N. D., "Fire Hazard Tests with Masonry Chimneys," *NFPA Publication*, No. Q-43-7, Boston, Oct. 1949.
126. Clinton Wire Cloth Company, *Some Test Data on Fireproof Floor Construction Relating to Cinder Concrete, Terra Cotta and Gypsum*, Clinton, 1913.
127. Structural Engineers Association of Southern California, Fire Ratings Subcommittee, "Fire Ratings, A Report," part of *Annual Report*, Los Angeles, 1962, pp. 30–38.
128. Lawson, D. I., Fox, L. L., and Webster, C. T., "The Heating of Panels by Flue Pipes," *Fire Research, Special Report*, No. 1, Dept. of Scientific and Industrial Research and Fire Offices' Committee, London, HMSO, 1952.
129. Forest Products Laboratory, "Fire Resistance of Wood Construction," excerpt from "Wood Handbook—Basic Information on Wood as a Material of Construction with Data for its Use in Design and Specification," *Dept. of Agriculture Handbook*, No. 72,

- Washington, 195_, pp. 337-350.
130. Goalwin, D. S., "Properties of Cavity Walls," *Building Materials and Structures*, Report BMS 136, National Bureau of Standards, Washington, May 1953.
131. Humphrey, R. L., "The Fire-Resistive Properties of Various Building Materials," *Geological Survey Bulletin*, 370, Washington, 1909.
132. National Lumber Manufacturers Association, "Comparative Fire Test on Wood and Steel Joists," *Technical Report*, No. 1, Washington, 1961.
133. National Lumber Manufacturers Association, "Comparative Fire Test of Timber and Steel Beams," *Technical Report*, No. 3, Washington, 1963.
134. Malhotra, H. L., and Morris, W. A., "Tests on Roof Construction Subjected to External Fire," *Fire Note*, No. 4, Dept. of Scientific and Industrial Research and Fire Offices' Committee, Joint Fire Research Organization, London, HMSO, 1963.
135. Brown, C. R., "Fire Tests of Treated and Untreated Wood Partitions," Research Paper, RP 1076, part of *Journal of Research of the National Bureau of Standards*, vol. 20, Washington, Feb. 1938, pp. 217-237.
136. Underwriters' Laboratories, "Report on Investigation of Fire Resistance of Wood Lath and Lime Plaster Interior Finish," *Publication*, SP.1.230, Chicago, Nov. 1922.
137. Underwriters' Laboratories, "Report on Interior Building Construction Consisting of Metal Lath and Gypsum Plaster on Wood-Supports," *Retardant*, No. 1355, Chicago, 1922.
138. Underwriters' Laboratories, "An Investigation of the Effects of Fire Exposure upon Hollow Concrete Building Units," *Retardant*, No. 1555, Chicago, May 1924.
139. Moran, T. H., "Comparative Fire Resistance Ratings of Douglas Fir Plywood," *Douglas Fir Plywood Association Laboratory Bulletin*, 57-A, Tacoma, 1957.
140. Gage Babcock & Association, "The Performance of Fire Protective Materials under Varying Conditions of Fire Severity," Report 6924, Chicago, 1969.
141. International Conference of Building Officials, *Uniform Building Code*, Whittier, CA, 1979.
142. Babrauskas, V., and Williamson, R. B., "The Historical Basis of Fire Resistance Testing, Part I and Part II," *Fire Technology*, vol. 14, no. 3 & 4, Aug. & Nov. 1978, pp. 184-194, 205, 304-316.
143. Underwriters' Laboratories, "Fire Tests of Building Construction and Materials," 8th ed., *Standard for Safety*, UL263, Chicago, 1971.
144. Hold, H. G., *Fire Protection in Buildings*, Crosby, Lockwood, London, 1913.
145. Kollbrunner, C. F., "Steel Buildings and Fire Protection in Europe," *Journal of the Structural Division*, ASCE, vol. 85, no. ST9, Proc. Paper 2264, Nov. 1959, pp. 125-149.
146. Smith, P., "Investigation and Repair of Damage to Concrete Caused by Formwork and Falsework Fire," *Journal of the American Concrete Institute*, vol. 60, Title no. 60-66, Nov. 1963, pp. 1535-1566.
147. "Repair of Fire Damage," 3 parts, *Concrete Construction*, March-May, 1972.
148. National Fire Protection Association, *National Fire Codes: A Compilation of NFPA Codes, Standards, Recommended Practices and Manuals*, 16 vols., Boston, 1978.
149. Ingberg, S. H. "Tests of Severity of Building Fires," *NFPA Quarterly*, vol. 22, no. 1, July 1928, pp. 43-61.
150. Underwriters' Laboratories, "Fire Exposure Tests of Ordinary Wood Doors," *Bulletin of Research*, no. 6, Dec. 1938, Chicago, 1942.
151. Parson, H., "The Tall Building under Test of Fire," *Red Book*, no. 17, British Fire Prevention Committee, London, 1899.
152. Sachs, E. O., "The British Fire Prevention Committee Testing Station," *Red Book*,

- no. 13, British Fire Prevention Committee, London, 1899.
153. Sachs, E. O., "Fire Tests with Unprotected Columns," *Red Book*, No. 11, British Fire Prevention Committee, London, 1899.
154. British Fire Prevention Committee, "Fire Tests with Floors: A Floor by the Expanded Metal Company," *Red Book*, no. 14, London, 1899.
155. *Engineering News*, vol. 56, Aug. 9, 1906, pp. 135–140.
156. *Engineering News*, vol. 36, Aug. 6, 1896, pp. 92–94.
157. Bauschinger, J., *Mitteilungen de Mech.-Tech. Lab. der K. Tech. Hochschule, Munchen*, vol. 12, 1885.
158. *Engineering News*, vol. 46, Dec. 26, 1901, pp. 482–486, 489–490.
159. *The American Architect and jBuilding News*, vol. 31, March 28, 1891, pp. 195–201.
160. British Fire Prevention Committee, First International Fire Prevention Congress, *Official Congress Report*, London, 1903.
161. American Society for Testing Materials, *Standard Specifications for Fire Tests of Materials and Construction (C19-18)*, Philadelphia, 1918.
162. International Organization for Standardization, *Fire Resistance Tests on Elements of Building Construction (R834)*, London, 1968.
163. *Engineering Record*, vol. 35, Jan. 2, 1897, pp. 93–94; May 29, 1897, pp. 558–560; vol. 36, Sept. 18, 1897, pp. 337–340; Sept. 25, 1897, pp. 359–363; Oct. 2, 1897, pp. 382–387; Oct. 9, 1897, pp. 402–405.
164. Babrauskas, Vytenis, "Fire Endurance in Buildings," PhD Thesis. *Fire Research Group*, Report, No. UCB FRG 76-16, University of California, Berkeley, Nov. 1976.
165. The Institution of Structural Engineers and The Concrete Society, *Fire Resistance of Concrete Structures*, London, Aug. 1975.
166. English Heritage, *Timber Paneled Doors and Fire*, An English Heritage Technical Guidance Note, London, May 1997.
167. Ruikar, V.G. "Report on the 1-Hour Fire Endurance Test of Superlite I XL Glazing in a Hollow Metal Frame and Door System," WHI Report No. 495–1324 of 1/17/95, Inchscape Testing Services, Warnock Hersey, Pittsburg, California.

U.S. Department of Housing and Urban Development
HUD USER
P.O. Box 6091
Rockville, MD 20849

FIRST CLASS MAIL
POSTAGE & FEES PAID
HUD
Permit No. G-795

Official Business
Penalty for Private Use \$300

February 2000

