

**LOWER COLORADO RIVER AUTHORITY
TRAVIS AND WILLIAMSON COUNTIES**

96-483-164 final

**BIOSOLIDS LAND APPLICATION AND COMPOSTING
FEASIBILITY STUDY**

November 13, 1996

FINAL REPORT

Prepared for:
Lower Colorado River Authority
P.O. Box 220
Austin, Texas 78767-0220
(512) 473-3333

Prepared by:
E&A Environmental Consultants, Inc.
1130 Kildaire Farm Road, Suite 200
Cary, North Carolina 27511
(919) 460-6266

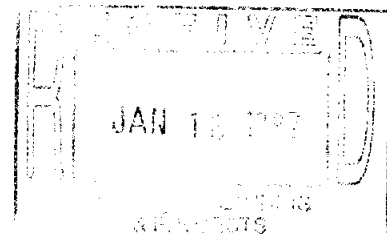

**LOWER COLORADO RIVER AUTHORITY
TRAVIS AND WILLIAMSON COUNTIES**

**BIOSOLIDS LAND APPLICATION AND COMPOSTING
FEASIBILITY STUDY**

November 13, 1996

FINAL REPORT

Prepared for:
Lower Colorado River Authority
P.O. Box 220
Austin, Texas 78767-0220
(512) 473-3333

Prepared by:
E&A Environmental Consultants, Inc.
1130 Kildaire Farm Road, Suite 200
Cary, North Carolina 27511
(919) 460-6266

(This report is printed on recycled paper).

TABLE OF CONTENTS

	Page
EXECUTIVE SUMMARY	i
Table 1 - Biosolids Management Cost Comparison	iii
 CHAPTER 1	
1.0 - INTRODUCTION	1
 CHAPTER 2	
2.0 - BIOSOLIDS GENERATION DATA	2
Table 2-1 - Estimated Sludge/Biosolids Generation From Participating Communities	4
Table 2-2 - Sludge Generation Rates per Million Gallons Sewage Treated ...	5
Table 2-3 - June 1996 Biosolids Chemical Characteristics for Participating Entities	after Pg. 5
 CHAPTER 3	
3.0 - REGULATORY REVIEW	6
3.1 - EPA PART 503 REGULATIONS	6
3.1.1 - Metal Constituent Concentrations	6
Table 3-1 - EPA Biosolids Pollutant Level Limits	7
3.1.2 - Pathogen Reduction Classification	7
Table 3-2 - Pathogen Reduction Criteria/Management Practices	9
Table 3-3 - Pathogen Reduction Alternatives for Class A Compost	10
3.1.3 - Vector Attraction Criteria	10
Table 3-4 - Summary of Options for Meeting Vector Attraction Reduction ...	11
3.1.4 - Monitoring, Record Keeping, and Reporting Requirements	11
Table 3-5 - Monitoring Frequency	11
Table 3-6 - Land Application Record Keeping Requirements	12
3.2 - TNRCC CHAPTER 312 REGULATIONS FOR SLUDGE USE, DISPOSAL, AND TRANSPORT	12
Table 3-7 - Annual Transportation Fee	13
3.2.1 - Public Notice for Land Application Projects	14
3.3 - TNRCC CHAPTER 332 REGULATIONS FOR BIOSOLIDS COMPOSTING ..	15
Figure 1	18
Table 1 - Maximum Allowable Concentrations	18
Figure 2	19
Table 2 - Maturity and Stability	19
Figure 3	19
Table 3 - Additional Final Product Standards	19
3.3.1 - Composting Facility Public Notice Requirements	19

CHAPTER 4

4.0 - TECHNOLOGY ASSESSMENT 21

4.1 - OVERVIEW OF LAND APPLICATION TECHNOLOGIES 21

Table 4-1 - Advantages and Disadvantages of Land Application 23

4.2 - LAND APPLICATION TECHNOLOGIES ASSESSMENT 23

4.2.1 - Area Requirements 23

Table 4-2 - Nitrogen Uptake of Agricultural Crops 23

Table 4-3 - Estimates of Ammonia Nitrogen Retained After Application 24

Table 4-4 - Summary of Biosolids Land Application Quantities Per Acre 25

4.2.2 - Site and Utility Requirements 25

4.2.3 - Capital and Operating Costs 26

4.2.4 - Environmental Controls 26

4.2.5 - Staffing 26

4.2.6 - Summary of Comparable Biosolids Land Application Programs 27

Table 4-5 - Land Application Facilities 28

4.3 - OVERVIEW OF COMPOSTING TECHNOLOGIES 29

4.3.1 - Process Overview 29

4.3.2 - Bulking Agents 31

4.3.3 - Composting Systems 32

Figure 4-1 - Composting Generalized Flow Diagram after Pg. 33

Table 4-6 - Advantages and Disadvantages of Windrow Composting 34

Table 4-7 - Advantages and Disadvantages of Aerated Static Pile Composting 35

Table 4-8 - Advantages and Disadvantages of Agitated Bed Composting Systems 36

4.3.3.1 - Windrow Composting Systems 36

Figure 4-2 - Windrow Composting System after Pg. 36

4.3.3.2 - Aerated Static Pile Systems 37

4.3.3.3 - In-Vessel Composting Systems 38

Figure 4-3 - Extended Aerated Static Pile Composting after Pg. 38

4.4 - COMPOSTING TECHNOLOGIES ASSESSMENT 39

Figure 4-4 - Agitated Bed Typical Configuration after Pg. 39

4.4.1 - Area Requirements 40

Table 4-9 - Compost Facility Land Area Requirements 40

4.4.2 - Site and Utility Requirements 41

4.4.3 - Capital and Operating Costs 42

4.4.4 - Environmental and Odor Control 43

4.4.5 - Staffing Requirements 45

Table 4-10 - Compost Facility Staffing Requirements 45

4.4.6 - Summary of Comparable Biosolids Composting Facilities 46

4.4.6.1 - Aerated Agitated Bed Facilities 46

Table 4-11 - Compost Facility Summary after Pg. 46

4.4.6.2 - Aerated Static Pile Facilities 47

4.4.6.3 - Un-aerated Windrow Facilities 48

4.4.6.4 - Aerated Windrow Facilities 49

4.5 - COMPARISON OF LAND APPLICATION VS. COMPOSTING	49
Table 4-12 - Advantages and Disadvantages of Land Application vs. Composting	51

CHAPTER 5

5.0 - MARKET RESEARCH	52
5.1 - LCRA BIOSOLIDS COMPOST MARKETING RESEARCH	52
5.1.2 - Market Segments	52
5.1.2.1 - Landscapers	53
5.1.2.2 - Growers	54
5.1.2.3 - Garden Centers	54
Table 5-1 - Retail Compost Prices - Bulk	55
Table 5-2 - Retail Compost Prices - Bagged	56
5.1.2.4 - Landscape Materials Suppliers	56
Table 5-3 - Wholesale Compost Prices - Bulk	57
5.1.3 - Current Estimated Compost Demand	58
Table 5-4 - Preliminary Current Compost Use Estimates for the Travis and Williamson County Area	58
5.1.4 - Competing Products	58
5.1.5 - Conclusions	59
5.2 - BULKING AGENT SOURCES FOR COMPOSTING	60
5.2.1 - Bulking Agent Requirements	60
5.2.2 - Local Bulking Agent Availability	61
Table 5-5 - Potential Bulking Agent Sources	62
5.3 - POTENTIAL LAND RESOURCES FOR LAND APPLICATION/COMPOSTING	65
Site Investigation Study Area 1	after Pg. 65
Site Investigation Study Area 2	after Pg. 65
5.3.1 - Land Requirements	66
5.3.2 - Land Related Issues	66
5.3.3 - Available Land	67

CHAPTER 6

6.0 - PRELIMINARY DESIGN	70
6.1 - ALTERNATIVES SECTION	70
6.2 - LAND APPLICATION DESIGN CRITERIA	72
Table 6-1 - Annual Dry Tons Generated	72
Table 6-2 - Acreage Needed for Application of Biosolids W/28.4 Lb. Available Nitrogen/Dry Ton	73
Table 6-3 - Residual Nitrogen Due to Previous Application	74
6.2.2 - General Design Criteria	74
6.2.2.1 - Material Transport	74

6.2.2.2 - Material Storage	74
Table 6-4 - Typical Crop Rotations and Wet Month Rainfall in the Travis and Williamson County Areas	75
6.2.2.3 - Operating Schedules	75
6.2.2.4 - Side Condition Assumptions	76
6.2.2.5 - Applying	76
6.3 - COMPOSTING DESIGN CRITERIA	77
6.3.1 - Biosolids Processing Capacity	77
6.3.2 - General Composting Design Criteria	78
6.3.2.1 - Materials Transport	78
6.3.2.2 - Materials Delivery, Receiving, and Storage	78
6.3.2.3 - Operating Schedules	79
6.3.2.4 - Site Condition Assumptions	79
6.3.2.5 - Odor Control Technology	79
6.3.3 - Aerated Static Pile Composting Facility	80
6.3.3.1 - Biosolids Receiving	80
6.3.3.2 - Yard Waste Receiving/Processing	80
Figure 6-1 - Aerated Static Pile Process Flow Diagram	after Pg. 80
6.3.3.3 - Mixing	81
6.3.3.4 - Composting	81
Figure 6-2 - Aerated Static Pile Typical Extended Pile Configuration Cross Section	after Pg. 81
Figure 6-3 - Aerated Static Pile Typical Extended Pile Configuration Isometric	after Pg. 81
6.3.3.5 - Screening	82
6.3.3.6 - Curing and Storage	82
6.3.3.7 - Materials Balances	82
Table 6-5 - Materials Balance for LCRA 7.5 Dry Tons Per Day Aerated Static Pile	after Pg. 82
Table 6-6 - Materials Balance for LCRA 15 Dry Tons Per Day Aerated Static Pile	after Pg. 82
Figure 6-4 - Bulking Agent to Biosolids Ratio as a Function of Solids Concentration (Volumetric)	after Pg. 83
Figure 6-5 - Bulking Agent to Biosolids Ratio as a Function of Solids Concentration (Gravimetric)	after Pg. 83

CHAPTER 7

7.0 - COST ANALYSIS	84
7.1 - LAND APPLICATION COST ANALYSIS	84
7.1.1 - Capital Costs	84
7.1.2 - Operations and Maintenance Costs	84
Table 7-1 - Operations and Maintenance Cost Summary	85

7.1.3 - Labor	85
Table 7-2 - Labor Requirements	85
7.1.4 - Transportation Costs	85
7.1.5 - Annualized Costs	86
Table 7-3 - Land Application Cost Summary	86
7.2 - COMPOSTING COST ANALYSIS	86
7.2.1 - Site Layouts	86
Figure 7-1 - Facility Layout - Aerated Static Pile 7.5 DTPD	after Pg. 86
Figure 7-2 - Facility Layout - Aerated Static Pile 15 DTPD	after Pg. 86
7.2.2 - Land Area Requirements	87
Table 7-4 - Land Area Requirements	87
7.2.3 - Capital Costs	87
Table 7-5 - Capital Cost Summary	88
7.2.3.1 - Sitework	88
7.2.3.2 - Pads and Walls	88
7.2.3.3 - Structures	88
7.2.3.4 - Odor Control	88
Table 7-6 - Capital Cost Estimate - LCRA Aerated Static Pile Composting Facility 7.5 DTPD	after Pg. 88
Table 7-7 - Capital Cost Estimate - LCRA Aerated Static Pile Composting Facility 15 DTPD	after Pg. 88
7.2.3.5 - Stationary Equipment	89
7.2.3.6 - Mobile Equipment	89
7.2.3.7 - Utilities	89
7.2.3.8 - Other	89
7.2.4 - Operations and Maintenance Cost	89
Table 7-8 - Operations and Maintenance Cost Summary	90
7.2.4.1 - Labor	90
Table 7-9 - Labor Requirements	91
7.2.4.2 - Bulking Agent	91
7.2.4.3 - Maintenance	92
7.2.4.4 - Fuel	92
7.2.4.5 - Utilities	92
7.2.4.6 - Miscellaneous	92
7.2.5 - Compost Marketing Costs and Revenues	93
Table 7-10 - Compost Produced Marketing Costs and Revenues	93
7.2.6 - Annualized Costs	93
Table 7-11 - Aerated Static Pile Composting Estimated Annualized Costs	94

CHAPTER 8

8.0 - CONCLUSIONS	95
Table 8-1 - Biosolids Management Cost Comparison	98

APPENDIX A

LCRA Land Application Cost Estimates - Scenario 1, Land Apply All Biosolids

APPENDIX B

Texas Water Development Board Comments

**LOWER COLORADO RIVER AUTHORITY
TRAVIS AND WILLIAMSON COUNTIES
BIOSOLIDS LAND APPLICATION AND COMPOSTING
FEASIBILITY STUDY**

EXECUTIVE SUMMARY

The continued public health and safety, environmental quality, and economic well being of the rapidly growing Williamson and Travis Counties (Austin, Texas area) will depend on the availability of reliable, high quality wastewater treatment facilities of adequate capacity. Population growth in this region is expected to double in only ten year's time. Proper management of wastewater treatment process biosolids is an essential and challenging component of local government efforts to provide quality wastewater services. Land application and composting are two methods of beneficially using biosolids in an environmentally and economically acceptable manner. The Lower Colorado River Authority (LCRA) commissioned a study to evaluate the feasibility of developing a regional biosolids treatment and management project. Such a program would serve wastewater treatment plants in Southern Williamson and Northern Travis Counties. Ten communities and Municipal Utility Districts (MUDs) participated in the regional study with LCRA. They include:

Anderson Mill MUD	Leander
Brushy Creek MUD	Lost Creek MUD
Cedar Park	Manor
Georgetown	Pflugerville
Lakeway MUD	Round Rock

The primary objective of this study was to determine the viability of a regional program for beneficial use of biosolids and to recommend specific alternatives for implementation. The two technologies which were evaluated as part of this effort were land application and composting.

The primary material which is to be land applied or composted at a planned regional facility is dewatered biosolids. Presently, approximately eight dry tons of biosolids are generated

daily by the participating entities. The majority of the participants in this study have either belt filters or drying beds available for dewatering of biosolids. Three of the smaller to medium sized entities do not have dewatering facilities but are currently investigating dewatering alternatives as a means of minimizing their biosolids management costs. The biosolids generated by the participating entities have pollutant concentrations below state and federal exceptional quality standards. This indicates a high suitability for either land application or composting of these biosolids. Yard wastes and clean wood wastes which are currently generated by the participating entities appear to be available in abundant quantities for use as a bulking agent in a composting program should that be developed. A significant amount of farmland exists primarily in Eastern Williamson County and Northern Travis County for potential use as land application sites.

Table 1 Summarizes the costs associated with the land application and composting alternatives evaluated as compared to the overall average biosolids management costs currently experienced by the participating entities. The range of costs currently reported is extremely wide, between \$21 and \$2,600 per dry ton of biosolids managed. Of the ten entities, approximately one half have costs which are lower than the \$180 per dry ton average and approximately half have costs higher than the overall average. Smaller communities without dewatering equipment typically have higher costs with the larger facilities that have dewatering equipment installed having some of the lower costs. Most of the municipalities with lowest costs are landfilling biosolids and not beneficially using them. Capital costs associated with developing a land application program are on the order of \$200,000. Capital costs associated with developing a covered aerated static pile composting facility range between \$3.2 and \$4.9 million dollars. However, the land application program will require at least 800 acres to accommodate all of the biosolids generated, whereas a biosolids composting facility will require only 14 acres.

A phased approach can be utilized for the development of a regional facility using either of the two technologies or both technologies in a combined program. Critical issues which remain in order to develop a regional biosolids management program include:

- Time frame of implementation.
- Economic feasibility for each potential participant.
- Which entities are willing to participate.
- Identification and selection of potential sites.
- Establishing suitable transportation for dewatered biosolids and/or bulking agent if necessary.
- Establishment of agreements between participating entities and LCRA

**TABLE 1
BIOSOLIDS MANAGEMENT
COST COMPARISON**

	Approximate Total Annual Cost	Average Unit Cost (\$/Dry Ton)
Existing Programs	\$509,400	\$180
Alternative 1 Land Apply all Biosolids	\$244,500	\$86.40
Alternative 2 Compost all Biosolids	\$721,650	\$255

Notes: 1. Based on 2,830 dry tons/year
2. Assumes all biosolids are dewatered using belt filter presses or drying beds

1.0 - INTRODUCTION

The Lower Colorado River Authority (LCRA) received a planning grant from the Texas Water Development Board to study the feasibility of developing a regional biosolids treatment and disposal project. Such a program would serve wastewater treatment plants (WWTP's) in Southern Williamson and Northern Travis Counties. Ten communities or Municipal Utility Districts participated in the regional study with LCRA. Twelve WWTP's generate biosolids for potential reuse from these participating entities. The purpose of this study is to determine whether a regional program for beneficial reuse of biosolids is viable and to recommend specific alternatives for implementation. The two technologies which were determined at the outset of the project to be potentially viable include land application and composting. This study summarizes the results of this work effort. The following work elements were performed in the effort:

- Review of biosolids, quantity and quality, generated by the 12 WWTP's
- Review of U.S. EPA Part 503 and Texas National Resource Conservation Commission (TNRCC) Sludge Use Disposal Transportation and Composting Rules
- Technology assessment of land application and composting
- Market research on bulking agent supply, compost markets, and land resources available for such a project
- Preliminary design for land application and composting
- Detailed cost analysis
- Recommendations

2.0 - BIOSOLIDS GENERATION DATA

The ten participating entities (communities or Municipal Utility Districts) were surveyed to determine existing biosolids quantities, management practices, and costs. Table 2-1 summarizes the results of this survey effort. Written data was solicited from each participant and then followed up by telephone interview where necessary to validate data.

Approximately 2,830 dry tons of biosolids are generated annually (1995) from the 12 wastewater facilities shown or an average of 7.8 dry tons per calendar day. This equates to 10.9 dry tons per day on a five day per week operating schedule. All of the 12 wastewater treatment facilities aerobically digest their sludge using extended aeration or conventional aerobic digestion to generate biosolids. Accordingly, biosolids from all facilities is sufficiently stabilized to be suitable for land application or composting.

Nine of the 12 wastewater treatment facilities dewater their biosolids using either drying beds or belt filter presses. The Town of Manor thickens their biosolids for liquid hauling and also uses drying beds when weather conditions permit. From a total quantity perspective, 91% of the biosolids generated is currently dried or dewatered making it suitable for composting or land application. The balance of liquid biosolids is suitable for land application only unless dewatering is added.

Two entities (Brushy Creek and Manor) reported biosolids generation data for their facilities which was extremely high for their size. Therefore, an average amount of 0.5 dry tons per million gallons (MG) of wastewater treated was used to estimate biosolids production from these facilities based on the average of other plants (see Table 2-2). The biosolids generation data for Cedar Park was also suspected to be high. However, further data analysis is required to verify this. The impact of such an analysis (which is being performed through 1996) will likely yield a lower solids generation rate, which will lower the overall estimated annual biosolids production of all communities by as much as seven percent. For the purpose of discussion and evaluation of costs in this report, the conservative higher generation rate has been used.

Estimated population/generation growth data for nine of the ten entities showed ranges of expected growth of between 150 and 300 percent over the next ten years. Only Anderson Mill expected no growth increase because the land area served is completely built out. From this data, it is not unreasonable to expect a doubling in wastewater flows and, hence, biosolids production

over the next ten years from the current 2,830 dry tons per year to 5,600 dry tons per year or higher.

**TABLE 2-1
ESTIMATED SLUDGE/BIOSOLIDS GENERATION FROM PARTICIPATING COMMUNITIES**

Community/District	Average Wastewater Flow (MGD)	Average Influent BOD	Sludge Treatment Method	Sludge Dewatering Method	Current Method of Disposal	Annual Generation (Dry Tons)	% of Total	Solids Content (%TS)	Reported Cost of Disposal (\$/DT)	10 Year Growth Increase (%)	Yard Waste Data
Anderson Mill MUD	0.919	207	Aerobic Digestion	Gravity Thickened	Haul to Austin WWTP	197	7.0	3	399 ⁵	0	Yes
Brushy Creek MUD	0.379	NA	Aerobic Digestion	Gravity Thickened/ Sand Drying Beds	Landfill and Haul to Austin	69 ¹	2.4	4	319 ⁵	253	No
Cedar Park	1.21	191	Aerobic Digestion	Belt Filter Press	Landfill	420	14.8	20	81 ⁶	233	No
Georgetown	1.4	140	Aerobic Digestion	Sand Drying Bed	Landfill	59	4.8	60	25 ⁶	200	Yes
Georgetown	0.5	150	Extended Aeration	Belt Filter Press	Landfill	75.3		17	88 ⁶	200	
Lakeway MUD	0.485	165	Aerobic Digestion	Belt Filter Press	Landfill	110	3.9	18	255 ⁶	228	No
Leander	0.428	165	Extended Aeration	Sand Drying Beds	Landfill	77.4	2.7	1.5 to 2.1	581 ⁵	150	No
Lost Creek MUD	0.279	183	Aerobic Digestion	Gravity Thickened	Haul to Austin WWTP	35 ⁴	1.3	0.77	2141 ⁵	105	No
Manor	0.076	NA	Aerobic Digestion	Gravity Thickened/ Drying Beds	Haul to Austin and Landfill	14 ¹	0.5	≈ 60	2,633 ⁵	259	No
Pflugerville	1.14	139	Aerobic Digestion	Sand Drying Beds	Landfill	315 ²	11.1	60	21 ⁵	250	No
Round Rock	3.1	166	Aerobic Digestion	Belt Filter Press	Landfill	897 ³	51.5	14	120	138	Yes
Round Rock	3.4	147			Landfill	561 ³					
TOTAL	13.316					2,830 7.75 DT/calendar day 10.88 DT/day - 5 day per week basis					

Notes: Dry tonnage quantities are as reported by communities except as noted below.
¹Estimated using assumed generation of 0.5 dry tons per million gallons sewage treated.
²Calculated based on reported volume generated from drying beds, assumed density of 1,400 lbs/CY and assumed solids content of 60%TS.
³Calculated based on reported wet tonnage generated per week and 14%TS.
⁴Based on 1.092 million gallons at 7,727 mg/l
⁵Calculated value
⁶Reported value NA - not available

Table 2-3 summarizes biosolids chemical characteristics for the 12 wastewater treatment facilities. This data analyzes results obtained from grab samples collected in June 1996. Based on these analyses, the biosolids from all 12 plants meet exceptional (class A) quality standards according to the EPA Part 503 regulations. Further, metals concentration of all the biosolids are below Grade 1 Compost maximum levels with the exception of Brushy Creek's copper level which slightly exceeds the 1,020 mg/kg maximum level by 120 mg/kg. The effect of bulking agent dilution and that of other biosolids would reduce the copper concentration to well below the Grade 1 Compost level after composting. Therefore, based on this limited data, it appears that biosolids from all 12 wastewater plants is suitable for land application or composting.

TABLE 2-2
SLUDGE GENERATION RATES PER MILLION GALLONS SEWAGE TREATED

		Dry Tons	Q (MGD)	DT/MG
Anderson Mill		197	0.919	0.59
Cedar Park		420	1.21	0.95
Georgetown	San Gabriel	59	1.40	0.12
	Dove Springs	75.3	0.50	0.41
Lakeway		110	0.485	0.62
Leander		77.4	0.428	0.50
Round Rock		1458	6.5	0.61
Average ¹				0.54

Notes: ¹An average generation rate of 0.5 DT/MG is assumed for other plants listed in Table 2-1.

TABLE 2 - 3
 JUNE 1996 BIOSOLIDS CHEMICAL CHARACTERISTICS FOR PARTICIPATING ENTITIES

Travis/Williamson County Biosolids Project

CLASS	Grade 1 A	Compost	Lost Cr MUD	Cedar Park		Round Rock		Round Rock		Brushy Creek	Manor	G'Town		G'Town		Anderson		Leander
				West	East	West	East	San Gabriel	Dove Springs			Lakeway MUD	Mill MUD	Pflugger- ville				
Total Solids	%	NA	2.21	14.6	14.6	15.1	87.1	57.1	61.2	15.7	16.5	0.49	62.6	17				
Ammonia - N	mg/kg	NA	4810	2590	3940	3690	6690	3480	4740	1420	991	3430	2630	1340				
TKN	mg/kg	NA	55,100	62,200	75,900	63,800	61,700	45,700	27,300	46,000	53,000	67,500	48,200	58,600				
Nitrate	mg/kg	NA	23.0	77.6	24.6	3.51	1.5	1.68	1720	16.3	<3.06	<10.2	2.96	25.5				
Nitric	mg/kg	NA	<5.0	<5.0	65.9	5.53	1.11	2.01	57.8	3.29	15.3	<10.2	0.88	3.5				
Phosphorus	mg/kg	NA	32,300	32,400	26,900	44,300	28,800	12,400	14,600	22,300	23,100	26,900	20,450	18,620				
Potassium	mg/kg	NA	3100	4970	1750	4180	3690	1400	1220	1680	2920	5730	1800	4200				
Arsenic	mg/kg	41	<8.0	2.4	2.1	2.3	<1.0	<1.0	1.1	2.0	2.7	1.3	<1.0	1.8				
Cadmium	mg/kg	39	3.0	<4.0	10	7	2.0	3	2.0	<4.0	5.0	<4.0	<3.5	<12.0				
Chromium	mg/kg	1200	16.9	9.6	40.3	17.7	10.7	12.0	18.8	17.8	12.7	8.5	20.4	19.4				
Copper	mg/kg	1500	223	245	503	635	1242	482	451	690	394	99.7	841	494				
Lead	mg/kg	300	49	47	88	63	36	47	77	104	75	61	57	75				
Mercury	mg/kg	17	1.1	2.5	2.8	2.3	4.1	9.8	5.3	4.3	5.8	6.1	1.4	2.6				
Molybdenum	mg/kg	Monitor	75	4.2	16.4	34.9	5.2	6.5	5.8	4.3	5.6	3.3	4.5	7.7				
Nickel	mg/kg	420	10.0	14	35	8	14	12	10	<2.0	28	7	14.5	15.3				
Selenium	mg/kg	36	14.4	6.4	4.7	3.9	1.2	2.6	<1.0	5.7	3.3	2.4	1.1	4.8				
Zinc	mg/kg	2800	600	373	544	490	690	670	550	601	1050	230	963	908				
pH		NA	6.22	6.70	7.01	7.19	6.25	6.98	7.18	6.85	6.73	6.27	6.96	6.85				

Notes: 1. Values based on grab samples collected in June 1996

2. All concentrations reported in mg/kg on a dry weight basis

3. Class A ceiling concentrations according to EPA pilot 503

4. Grade 1 Maximum Allowable Concentrations according to TNRC Chapter 332

3.0 - REGULATORY REVIEW

Currently two sets of regulations govern biosolids treatment and disposal in Texas: Federal EPA 40 CFR Part 503 and the State of Texas Natural Resources Conservation Commission (TNRCC) Chapter 312 (Sludge Use, Disposal, and Transportation) and Chapter 332 (Composting, Mulching, and Land Application).

3.1 - EPA PART 503 REGULATIONS

The EPA Part 503 regulations apply to all beneficial use options including land application, composting, chemical stabilization and sludge drying. The regulation of all biosolids products which are distributed and marketed are addressed under land application requirements. Three general criteria categories are used to establish sludge quality and the degree to which biosolids must be monitored and how it can be utilized. These include metal constituent concentrations (concentration and ceiling levels), pathogen reduction criteria (Class A and Class B), and vector attraction criteria (processing or barrier induced). If a sludge management strategy meets the highest quality standards set forth in these three general criteria, it will be classified as "exceptional quality" sludge. Monitoring, record keeping, and reporting are required regardless of the biosolids quality. The following sections briefly describe these three general criteria categories as well as monitoring and record keeping requirements under EPA Part 503.

3.1.1 - Metal Constituent Concentrations

Metal constituent limits for land application are listed in Table 3-1.

TABLE 3-1
EPA BIOSOLIDS POLLUTANT LEVEL LIMITS

Parameter	Ceiling Limits	EQ Metal Concentration Limits	Cumulative Metal Loading Rate		Annual Metal Loading
	(mg/kg) ¹	(mg/kg) ¹	(kg/ha) ¹	(lb/ac) ¹	(lb/ac/yr) ¹
METALS					
Arsenic	75	41	41	36	1.8
Cadmium	85	39	39	35	1.7
Chromium	3000	1200	3000	2677	134
Copper	4300	1500	1500	1339	67
Lead	840	300	300	268	13
Mercury	57	17	17	15	0.76
Molybdenum	75	monitor	monitor	monitor	monitor
Nickel	420	420	420	375	18.7
Selenium	100	36	100	89	4.5
Zinc	7500	2800	2800	2500	125

¹ dry weight basis

To be applied to the land, bulk biosolids must meet the metal ceiling concentrations and cumulative metal loading rate limits. Bulk biosolids applied to lawns and home gardens must meet exceptional quality metal concentration limits. Biosolids sold or given away in bags must meet the metal concentration limits or annual sewage sludge product application rates that are based on the annual metal loading rates. For exceptional quality biosolids, there are no limitations on annual or cumulative loading rates.

3.1.2 - Pathogen Reduction Classification

Biosolids are classified into two categories, Class A and Class B, based upon certain pathogen reduction criteria. Pathogen reduction criteria include maximum concentrations of certain disease indicator organisms (salmonella, fecal coliform, enteric viruses, or helminth ova), and treating biosolids using certain specific methods and documenting the conditions of that method. A minimum of Class B pathogen reduction requirements must be met in order to land apply biosolids. Class A pathogen reduction (as well as metal concentration limits and vector

attraction criteria) requirements must be met in order to distribute and market biosolids products on lawn and home gardens. Land application of Class A biosolids requires compliance with certain minimal management practices. Further site restrictions are required to be met if only class B pathogen reduction requirements are met. Table 3-2 shows the criteria for land application under each pathogen reduction criteria.

TABLE 3-2
PATHOGEN REDUCTION CRITERIA/MANAGEMENT PRACTICES

Pathogen Reduction Criteria	Biosolids Management Practices Required
Class A	<ul style="list-style-type: none"> • Cannot apply biosolids to flooded, frozen or snow covered ground • Apply biosolids at agronomic rates • Maintain ten meter buffer from limit of application to surface water • Cannot apply in areas where threatened or endangered species would be adversely affected
Class B	<p>In addition to Class A requirements, the following criteria apply:</p> <ul style="list-style-type: none"> • Food crops with harvested parts that touch the biosolids/soil mixture (such as melons, squash, cucumbers, etc.) shall not be harvested for 14 months after application • Food crops with harvested parts below the soil surface (root crops such as potatoes, carrots, radishes) shall not be harvested for 20 months after application if the biosolids is not incorporated for at least four months. • Food crops with harvested parts below the soil surface (root crops such as potatoes, carrots, radishes) shall not be harvested for 38 months after application if the biosolids is incorporated in at less than four months. • Food crops, feed crops, and fiber crops shall not be harvested for 30 days after biosolids application. • Animals shall not be grazed on a site for 30 days after biosolids application. • Turf shall not be harvested for one year after biosolids application if the turf is placed on land with a high potential for public exposure of a lawn. • Public access to land with high potential for public exposure shall be restricted for 1 year after biosolids application. • Public access to land with low potential for public exposure shall be restricted for 30 days after biosolids application.

Table 3-3 shows a summary of the pathogen reduction alternatives outlined in the 503 rule. For pathogen reduction Alternative 1, a range of times and temperatures are allowed. The

temperature/times range from 50°C for 15 hours to 70°C for 15 minutes. Alternative 5 calls for maintenance of 55°C or greater for three consecutive days.

**TABLE 3-3
PATHOGEN REDUCTION ALTERNATIVES FOR CLASS A COMPOST**

<p>All Alternatives:</p> <ul style="list-style-type: none"> • Fecal coliform < 1000 MPN / gm Total Solids <u>OR</u> • Salmonella < 3 MPN / 4 gms Total Solids
<p>Alternative 1</p> <ul style="list-style-type: none"> • Temperature / Time mathematical relationship
<p>Alternative 2</p> <ul style="list-style-type: none"> • pH > 12 for > 72 hours and • Temp. > 52°C for 12 hours • After 12 hours > 50% solids reduction
<p>Alternative 3</p> <ul style="list-style-type: none"> • Virus < 1 PFU / 4 gms Total Solids • Helminth Ova < 1 viable ova / 4 gms Total Solids <p style="margin-left: 40px;">- untreated (sample by sample)</p> <p style="margin-left: 40px;">- Pathogen treatment process (operating parameters)</p>
<p>Alternative 4</p> <ul style="list-style-type: none"> • Virus < 1 PFU / 4 gms Total Solids • Helminth Ova < 1 viable ova / 4 gms Total Solids
<p>Alternative 5</p> <ul style="list-style-type: none"> • PFRP Temperatures > 55°C for three consecutive days
<p>Alternative 6</p> <ul style="list-style-type: none"> • PFRP equivalent

3.1.3 - Vector Attraction Criteria

Vector attraction reduction reduces potential for spreading of infectious diseases by vectors (flies, mosquitoes, rodents, and birds). There are 12 different vector attraction criteria in Part 503 of which at least one must be met to land apply sewage sludge. Table 3-4 summarizes these options. These criteria include processing options such as digestion as well as physical barrier options, including injection and incorporation of biosolids into the soil.

TABLE 3-4
SUMMARY OF OPTIONS FOR MEETING VECTOR ATTRACTION REDUCTION

<i>Option 1:</i>	Meet 38% reduction in volatile solids content.
<i>Option 2:</i>	Demonstrate vector attraction reduction with additional anaerobic digestion in a bench-scale unit.
<i>Option 3:</i>	Demonstrate vector attraction reduction with additional aerobic digestion in a bench-scale unit.
<i>Option 4:</i>	Meet a specific oxygen uptake rate for aerobically digested biosolids.
<i>Option 5:</i>	Use aerobic processes at greater than 40°C for 14 days or longer.
<i>Option 6:</i>	Alkali addition under specified conditions.
<i>Option 7:</i>	Dry biosolids with no unstabilized solids to at least 75% solids.
<i>Option 8:</i>	Dry biosolids with unstabilized solids to at least 90% solids.
<i>Option 9:</i>	Inject biosolids beneath the soil surface.
<i>Option 10:</i>	Incorporate biosolids into the soil within 6 hours of application to or placement on the land.
<i>Option 11:</i>	Cover biosolids placed on a surface disposal site with soil or other material at the end of each operating day. (NOTE: only for surface disposal).
<i>Option 12:</i>	Alkaline treatment of domestic septage to a pH of 12 or above for 30 minutes without adding more alkaline material.

3.1.4 - Monitoring, Record Keeping, and Reporting Requirements

The frequency of monitoring for metal constituents, pathogen densities, and vector attraction reduction requirements is based on the quantity of biosolids generated on an annual basis as shown in Table 3-5. Record keeping requirements vary according to the end use of the biosolids material and must be maintained for 5 years. Table 3-6 describes examples of records required.

TABLE 3-5
MONITORING FREQUENCY

Biosolids (dry tons per 365 day period)	Monitoring Frequency
> 0 to < 320	once per year
320 to < 1,650	once per quarter
1,650 to < 16,500	once per 60 days (6 times per year)
> 16,500	once per month (12 times per year)

TABLE 3-6
LAND APPLICATION RECORD KEEPING REQUIREMENTS

Biosolids Quality/Use	Records Required
Exceptional Quality	Metals constituent records, description of Class A pathogen reduction and vector attraction reduction
Land application w/physical barriers for vector attraction reduction	Certification that vector attraction reduction rules are followed
Class B pathogen reduction and below metal constituent limit	Certification that these criteria and site restrictions have been met
Land application of sludge with metal constituent above concentration limits	Certification of pathogen and vector attraction requirements and records on application date, site location, site size, and cumulative loading rates
Class A pathogen criteria above metal concentration limits and sold or given away	Certification of pathogen and vector reduction criteria used, annual application rate and record of annual metal loading rate

3.2 - TNRCC CHAPTER 312 REGULATIONS FOR SLUDGE USE, DISPOSAL, AND TRANSPORT

If a biosolids to be reused meets Class A pathogen reduction requirements, vector attraction reduction requirements, and metal concentration limits, a permit is not required. At least 30 days prior to engaging in reuse activities, a notification form must be submitted to the permitting section of the Watershed Management Division of the TNRCC. The notification shall contain:

- Sewage sludge composition, all points of generation, and wastewater treatment facility identification
- Name, address, and telephone number of all persons receiving sludge
- Description of marketing and distribution plans

Thirty days after the notification has occurred, activities may commence. Annually, on September 1, each person subject to notification of certain Class A activities must provide a report to the commission, on forms furnished by the commission, which describes all of the above mentioned activities. The report must include an update of new information since prior reporting and a description of annual amounts of sewage sludge reused.

The following information will need to be included in a TNRCC permit application for a biosolids reuse project for materials not meeting the requirements listed above. The list below is an abbreviated description, and the full requirements can be found in Section 312.11 of the TNRCC Sludge Use document.

- An original and several copies, as specified by the permit authority
- Site map depicting the approximate boundaries of the tract of land owned and all residents and businesses within 1/2 mile of the site
- Operator name, address, telephone number
- Determination of whether the facility is located on Native American lands
- Legal owners of the land
- Description of the biosolids
- Description of all processes generating the biosolids
- Detailed description of the beneficial use occurring at the site
- Information describing soil characteristics and subsurface conditions
- Analytical results for metals regulated by this document for the soil and biosolids
- Analytical results for nutrients, salinity, soil pH for the biosolids and the soil

The TNRCC sludge reuse regulations do not apply to sludge containing 50 ppm or greater of PCB's. Additional and more stringent regulations may be imposed at the discretion of the TNRCC on a case by case basis. Reporting requirements include notification of when a site reaches 90% of its cumulative loading limit and reporting of any application which occurs after this point has been reached.

Fees due to the TNRCC for the reuse of biosolids are as follows. A minimum of \$100 is due annually, regardless of whether the site is active or in-active. For Class A biosolids, \$0.20 per dry ton fee will be collected. For Class B, \$0.75 per dry ton will be collected. In addition, an annual transportation fee will be required as follows in Table 3-7.

**TABLE 3-7
ANNUAL TRANSPORTATION FEE**

Gallons	Fee
less than or equal to 10,000	\$100
10,000 - 50,000	\$250
50,000 - 200,000	\$400
greater than 200,000	\$500

In addition to monitoring requirements for the biosolids, soil will need to be monitored at the application sites for metals and nutrients. All of the metals listed above must be monitored in the soil. Nutrients, salinity, and pH in the top six feet as well as in the 6 to 24 foot zone must be monitored as well. One composite sample must be taken for every 80 acres of land at an application site.

For class B material, there are ground and surface water restrictions which must be met. For slow permeable soils, the seasonal high water mark must be three feet below the application zone. For rapid permeable soils, a four foot buffer is required. Other buffers for Class B materials include:

- Not incorporated within 48 hours - to surface water 200 feet
- Incorporated within 48 hours - to surface water 33 feet
- Private water supply well 150 feet
- Public water supply well 500 feet
- Solution channel, sinkhole, or conduit to groundwater 200 feet
- School, institution, business, or occupied residential structure 750 feet
- Public right of way 50 feet
- Irrigation conveyance canal 10 feet
- Property boundary 50 feet

Several site restrictions apply to Class B materials as well. These include:

- Harvesting of food crops above ground - 14 months after application
- Food crops below ground - 20 months when incorporated after 4 months on the ground
- Food crops below ground - 38 months when incorporated before the materials have been on the ground for four months
- Food, feed, fiber - 30 days
- Grazing - 30 days
- Turf grass - 1 year
- Public access with high potential for exposure - 1 year
- Public access with low possibility for exposure - 30 days

3.2.1 - Public Notice for Land Application Projects

Notice is required only if Class B materials are applied. Notice is not required if Class A biosolids are applied. If applying Class B materials, the chief clerk of the commission will mail a notice of receipt of application and declaration of administrative completeness, along with a copy of the registration application, to the county judge in the county where the proposed site for land application of biosolids is located. The chief clerk of the commission will also mail these items to the landowners named on the application map or in the application. Each notice will specify

both the name, affiliation, address, and telephone number of the applicant and of the commission employee who may be reached to obtain more information about the application to register the site. The notices shall specify that the registration has been provided to the county judge and that it is available for review.

A person may provide the commission with written comments on any new or major amendment applications to register a site for land application of sewage sludge. The executive director shall review any written comments when they are received within 30 days of the notice. The written information will be utilized by the executive director in determining what action to take on the application for registration.

3.3 - TNRCC CHAPTER 332 REGULATIONS FOR BIOSOLIDS COMPOSTING

The TNRCC has adopted a tiered regulatory approach which considers the size of an operation and the type of materials being composted. This approach is used to determine which regulations apply and what level of permitting is required. Facilities which compost septage tank waste or sewage sludge (biosolids) with bulking agents other than yard trimmings or clean wood material are classified as compost facility type CA, and require the owner or operator to submit an application prepared in accordance to Section 332.60(c)(1) of the TNRCC Composting, Mulching, and Land Application document. The document listed above states that no composting or mulching activities shall be conducted on the cap of a landfill without prior approval by the commission on a case-by-case basis. A permit application can be obtained from and when completed should be submitted to the TNRCC at the following address:

TNRCC Municipal Solid Waste Division
P.O. Box 13807
Austin, TX 78711-13087
(512) 239-6717

Biosolids composting projects which use only yard trimmings and clean wood materials will require registration and are subject to the general requirements, operating requirements, and end-product requirements of the TNRCC Chapter 332 document. This scenario is that which is assumed to apply for the purposes of composting facilities evaluated for LCRA as part of this report. The provisions of this document are described below.

General requirements include compliance with the Texas Water Code designed to prevent pollution of the surface or ground water. Operations must be conducted in accordance with Federal and State regulations. If operations are conducted at a solid waste facility or a wastewater treatment facility, permit amendments must be obtained.

An air permit must be obtained under the authority of the Texas Clean Air Act. All roads must be treated, watered, paved and/or cleaned in order to achieve dust control. Prior to obtaining quantities of potentially odorous feedstocks, adequate bulking agent must be on site for proper mixing. When materials are pneumatically conveyed, air must be vented to the atmosphere through a fabric filter having a maximum filter velocity of four feet per minute. Grinders and conveyors must use sprayer systems for dust control.

Operational requirements for registered facilities include the following:

- Certification by a registered engineer (State of Texas Registration)
- Ownership or control of property by operator
- Inspection of facility prior to acceptance of any new feedstock type

Registration applications for composting must include:

- Title page
- Signature of applicant
- Affidavit verifying land ownership and landowner agreement of proposed activity
- Table of contents
- Legal authority
- Evidence of competency
- Notice of Appointment
- Notice of Coordination
- Legal description
- Location description
- Landowner list
- Site operating plan
- Process description
 - feedstock identification
 - tipping process, process, post process
 - production distribution
 - process diagram
- Personnel
- Security

Location standards for facilities include:

- Outside of 100 year flood plain, unless applicant can demonstrate that washout will not occur
- Shall not significantly alter existing drainage plans
- Shall be located at least 500 feet from all public water wells and at least 150 feet from private water wells
- Shall be at least 100 feet from creeks, rivers, intermittent streams, lakes, bayous, bays, estuaries, or other surface waters in the state
- Subject to Chapter 313 if located above the Edwards Aquifer Recharge Zone

Operational standards include:

- Collect and manage the 25 year 24 hour storm water flow
- Liners must be employed consisting of soil, synthetic material, or alternative that is equivalent to two feet of compacted clay with a hydraulic conductivity of 1×10^{-7} centimeters per second or less
- Preclude the entry of any prohibited materials
- Control access to site
- Prevent nuisance and fire hazard
- Aerobic composting must be achieved
- A site sign must be in place
- Access road must be an all weather road
- End product standards must be met
- A TNRCC certified compost operator must be employed within six months of beginning operations (once the certification program is available).

TNRCC defines compost grades as Grade 1, Grade 2, and Waste Grade compost. These are defined by the level of treatment, pollutants, and maturity of the compost. Foreign matter, maturity, metals content, pathogen reduction, salinity, and pH are all used to define the grade of a finished compost.

Grade 1 compost (no restriction on end use):

- Shall contain no foreign matter of a size or shape that can cause harm to a human or animal
- Shall not exceed maximum allowable concentrations for Grade 1 compost as described in Figure 1
- No foreign matter greater than 1.5% dry weight on a 4mm screen
- Meet cured compost requirement of Figure 2
- Meet pathogen reduction requirements of Figure 3
- Meet salinity and pH requirements as described in Figure 3

Grade 2 compost (shall not be used at a residence or licensed child care facility):

- Shall contain no foreign matter of a size or shape that can cause harm to a human or animal
- Shall not exceed maximum allowable concentrations for Grade 2 compost as described in Figure 1
- No foreign matter greater than 1.5% dry weight on a 4mm screen
- Meet semi-mature, mature, or cured compost requirement of Figure 2
- Meet pathogen reduction requirements of Figure 3
- Meet salinity and pH requirements as described in Figure 3

Waste Grade compost:

- Exceed maximum allowable concentrations for Grade 2 compost
- Does not meet any of the other requirements of Grade 1 or Grade 2 compost

Labeling requirements include:

- Grade of compost
- Feedstock description
- Soil incorporation guidelines (mix into 15 inches of soil)

FIGURE 1: 30 TAC 332.72

**TABLE 1
MAXIMUM ALLOWABLE CONCENTRATIONS
(mg/kg on a dry weight basis)**

Parameter	Grade 1 Compost (mg/kg)	Grade 2 Compost (mg/kg)
As	10	41
Cd	16	39
Cr (total)	180	1,200
Cu	1,020	1,500
Pb	300	300
Hg	11	17
Mo	75	75
Ni	160	420
Se	36	36
Zn	2,190	2,800
PCBs	1	10

FIGURE 2: 30 TAC 332.72

**TABLE 2
MATURITY AND STABILITY STANDARDS**

Method	Semi-Mature Compost	Mature Compost	Cured Compost
Reduction of Organic Matter (ROM) (%)	Between 20% and 40%	Between 40% and 60%	Greater than 60%
Other Methods	Maturity Protocol	Maturity Protocol	Maturity Protocol

FIGURE 3: 30 TAC 332.72

**TABLE 3
ADDITIONAL FINAL PRODUCT STANDARDS**

Parameter	Grade 1 Compost	Grade 2 Compost
Salinity ¹ (mmhos/cm)	10	10
pH	5.0 to 8.5	5.0 to 8.5
Pathogens:		
Fecal Coliform	Less than 1,000 MPN per gram of solids or meets PFRP	Geometric mean density less than 2,000,000 MPN per gram of solids or meets PSRP
Salmonella	Less than 3 MPN per 4 grams total solids or meets PFRP	No value

Note: 1 A higher conductivity of pH outside the indicated range may be appropriate if the compost is specified for a special use.

3.3.1 - Composting Facility Public Notice Requirements

When the application is complete, the chief clerk will mail notice to the identified adjacent landowners. The chief clerk will also mail notice to the other affected landowners as directed by

the executive director. The applicant will publish notice in the county in which the facility is located, and in adjacent counties. The published notice should be published once a week for three weeks, and an effort must be made to put the notice in the Sunday paper. The notice must explain the method for submitting a motion for reconsideration. The notice must contain the following information:

- the identifying number given the application by the executive director
- the type of registration sought under the application
- the name and address of the applicant
- the date on which the application was submitted
- a brief summary of the information included in the application

The executive director will, after review of any application for registration of a compost facility determine if he will approve or deny an application in whole or in part. The executive director will base his decision on whether the application meets the requirements. At the time that the decision is mailed to the applicant, copies will be sent to the adjacent landowners, residents, and businesses.

A decision by the executive director, including a registration issued by the executive director, is not affected by the filing of a motion for reconsideration under this section unless expressly so ordered by the commissioners. If a motion for reconsideration is not acted on by the commissioners within 45 days after the date on which the chief clerk mailed the signed registration to the applicant, the motion will be deemed overruled.

4.0 - TECHNOLOGY ASSESSMENT

This chapter provides an overview of beneficial use options which are being considered for biosolids management by LCRA. A variety of municipal biosolids management alternatives are available today which have been successfully demonstrated. Only the beneficial use options of land application and composting are the specific processes being considered in this study. These processes include the following:

Land Application:

- Liquid biosolids subsurface injection
- Surface application of dewatered biosolids
- Surface application and incorporation of dewatered biosolids

Composting:

- Aerated static pile
- Aerated turned windrow
- Unaerated turned windrow
- Aerated agitated bed

This chapter provides an overview of the technologies being considered as well as an assessment of the existing practices of these technologies throughout the United States. It finishes with the comparison of land application and composting technologies.

4.1 - OVERVIEW OF LAND APPLICATION TECHNOLOGIES

Land application of stabilized biosolids is widely practiced in the United States. Stabilization prior to land application is required to reduce pathogenic organisms present in the biosolids. The beneficial use of biosolids products is based on utilizing the macronutrients of nitrogen, phosphorus, and potassium and certain levels of trace elements (such as copper, selenium, and boron) to benefit the growth of plants, including grasses, agricultural crops, and trees.

Biosolids from the facilities can be considered a low grade fertilizer, and application rates can be calculate based upon the agronomic needs of the target crop. The nitrogen level in the biosolids will likely be the limiting factor, so the loading rates are given in dry pounds nitrogen

per acre. The application method will affect the rate of plant available nitrogen due to different levels of loss to the atmosphere. For instant, if a material is surface applied and tilled in three days later, there will be much higher loss of ammonia nitrogen to the atmosphere than if the biosolids are subsurface injected. Assuming that the biosolids meet the 503 EQ level requirements, the material can be applied agronomically.

The quantity of biosolids that can be applied to land must be calculated for each specific site, soil, and crop to meet the current and future guidelines for metal addition and to ensure no over application of nitrogen to the soil. Where there is no path to the food chain, (landscaping, forest, site reclamation), heavier application rates may be considered.

Biosolids are applied to land either as a liquid, thickened, or dewatered material. Liquid biosolids are commonly applied by surface or injection techniques. Truck mounted spray equipment and spray irrigation systems are suitable for surface applications. Specially designed biosolids application vehicles are used for subsurface injection. Dewatered biosolids can be surface applied and incorporated into the soil with conventional tilling equipment.

Liquid or thickened biosolids transported to the agricultural application site using a tanker truck. Dewatered biosolids are hauled in a sealed or trailer truck. Liquid/thickened material can be applied using:

- a spray bar fitted behind a towed or self powered tanker
- a spray irrigation nozzle mounted on a towed or self powered tanker
- spray irrigation nozzle, ground mounted, powered or pulled by cable
- a direct injection system, fitted to plow tines mounted behind a tanker vehicle
- a direct injection system, fitted to plow tines on a tractor attached to a long hose fed from a stationary tank

Where the biosolids product is applied to the ground surface, it can be left on the surface, eventually combining with the surface humus and litter layer (i.e. in the forest), or plowed or disced in and blended with the surface soil layers. Table 4-1 shows the advantages and disadvantages of agricultural land application.

TABLE 4-1

ADVANTAGES AND DISADVANTAGES OF LAND APPLICATION

ADVANTAGES	DISADVANTAGES
<ul style="list-style-type: none">• Potential for the development of additional capacity with minimal cost• Low cost alternative• Potential for use on multiple crop types• No biosolids dewatering necessary	<ul style="list-style-type: none">• Many potential agricultural uses are governed by seasonal demands, particularly in the farming sector• Spring and possibly autumn are high demand months• Storage capacity is required at the wastewater treatment plant to store thickened biosolids• Additional sites require additional permitting• Significant acreage of land is required to manage biosolids• Cannot be utilized during rainy weather

4.2 - LAND APPLICATION TECHNOLOGIES ASSESSMENT

This section of the report summarizes key factors involved in the design and operation of land application programs. Information that was gathered through the use of telephone surveys, site visits, and literature review is described in the following sub-sections.

4.2.1 - Area Requirements

The application rates and therefore the land requirements are dependent upon the application method, the site conditions, the biosolids nitrogen content, and the crops grown. Agricultural crop nutrient uptake rates have a wide range. Table 4-2 shows some examples of nitrogen uptake rates for a few specific crops.

TABLE 4-2

NITROGEN UPTAKE OF AGRICULTURAL CROPS

Crop	Nitrogen Uptake (dry lb/acre)
corn	240
corn silage	200
wheat	125
oats	150
alfalfa hay	330

Table 4-3 shows the estimated ammonia nitrogen retained after biosolids application for several different materials and application methods. This will help determine the available plant nitrogen in the biosolids over time.

TABLE 4-3
ESTIMATES OF AMMONIA NITROGEN RETAINED AFTER APPLICATION

Days to Incorporation by Tillage	Surface Applied				Injected Biosolids	Compost or Drying Bed Biosolids
	Liquid Biosolids, pH >7	Dewatered Biosolids, pH >7	Liquid or Dewatered pH <7	Lime Stabilized Biosolids		
	<i>Ammonia and Ammonium - Nitrogen Retained, Percent of Applied</i>					
0 to 2	80	60	90	10	100	100
3 to 6	70	50	90	10	100	100
over 6	60	40	90	10	100	100

Mineralization rates for biosolids range from 10 to 35%, but usually are in the range of 20% for the first year following application. For the purposes of this discussion, 20% will be used. Mineralization is the rate at which organic nitrogen is converted to plant available nitrogen. The example below shows the calculations necessary to estimate an agronomic loading rate of biosolids assuming the nitrogen contents as shown.

What follows is a brief summary of agronomic loading rate calculations and an estimate for acreage needed to apply biosolids. Typically, if land application is chosen as a reuse method, additional information is gathered concerning application site background information, application method, crop rotations, fertilizing practices, and more. This estimate assumes that the crop grown needs 200 pounds per acre of nitrogen and the incorporation method is subsurface injection, which means no nitrogen losses to the atmosphere. This is, therefore, a fairly conservative estimate relative to land area requirement.

Inorganic Nitrogen Content	0.3%
Pounds of Inorganic Nitrogen/Dry Ton	6
Organic Nitrogen Content	5.6%
Pounds Organic Nitrogen/Dry Ton	112
Mineralization Rate	20%
Pounds Inorganic Nitrogen/Dry Ton	22.4
Total Plant Available Nitrogen	28.4

Biosolids needed to satisfy agronomic needs: $200 \text{ lb/acre} \div 28.4 \text{ lb/dry ton} = 7.0 \text{ dry tons/acre}$

Table 4-4 describes the acreage needed for different solids content biosolids. The Table shows the difference between materials at 8, 15, 20, and 25% solids.

TABLE 4-4
SUMMARY OF BIOSOLIDS
LAND APPLICATION QUANTITIES PER ACRE

Percent Solids	Dry Tons per Acre	Wet Tons per Acre	Gallons per Acre
8%	7	88	21,000
15%	7	47	11,000
20%	7	35	8,200
25%	7	28	6,600

Once the acreage necessary is identified, additional site specific buffers are added to keep application away from surface waters, wells, other properties, etc. to determine land area for a given quantity of biosolids.

4.2.2 - Site and Utility Requirements

Typically, no site utilities are needed for land application programs. Site selection criteria are in line with agricultural practices. These criteria include looking for a site with little or no surface water in the vicinity. To avoid perceived or actual problems with surface water quality degradation, for example, the application of biosolids cannot occur within ten meters of U.S. surface waters, including tidal waters. In addition, the application of biosolids to an area cannot have an adverse effect on the likelihood of survival and recovery of an endangered or threatened species. Critical habitat includes any place where such a species lives and grows during its life cycle. Application to frozen or snow covered land is not prohibited, but controls must prevent runoff to surface areas. Common runoff controls include buffers, tillage, vegetative strips, berms, dikes, silt fences, etc.

4.2.3 - Capital and Operating Costs

Equipment requirements for land application of biosolids include manure spreaders or subsurface injection tanker/trucks, a soil tiller, and a tractor to pull the equipment. Materials are usually tilled within a short period of time (usually 24 hours). Dewatered biosolids are typically surface applied with a manure spreader type technology, while liquid biosolids (up to 8% solids) are often injected into the soil. This practice helps maintain a clean operation and reduces the volatilization of ammonia nitrogen while biosolids sit on the surface of the soil. The application of dewatered biosolids will require tilling into the soil within 24 hours of arrival at the site. These pieces of equipment can be truck or trailer mounted. Trailer mounted units are pulled by tractors or field trucks with hydraulic or PTO drive connections.

As reported by several contractors who land apply biosolids, operating and maintenance costs can range from \$20 to \$30/dry ton applied depending on site conditions and services rendered. These figures should be used for comparison only as no one contacted would commit to an exact figure for this expenditure. Additional operating and maintenance costs include fuel (approximately 20 gallons per hour), monitoring and lab analysis, salary overhead, and maintenance of equipment (5% of capital costs annually).

4.2.4 - Environmental Controls

In order to ensure control of potential environmental problems, the operations must occur within the designated application area, avoiding all defined buffer zones. In addition, if dewatered biosolids are applied, the material needs to be incorporated into the soil within 24 hours. This will help prevent vector attraction, odors, and volatilization of ammonia nitrogen. Also, strict adherence to the agronomic loading rate, which is designed to apply nutrients at a rate no higher than the uptake rate of the crop grown, will prevent degradation of surface and ground water.

4.2.5 - Staffing

Typically, one operator and applicator is required for each 200 wet tons of material applied per day. This operator can also operate the tiller with the same tractor. The time of a water/wastewater operations manager and an operations and maintenance coordinator will also be

required. Depending on the project size, these can range from 5% - 20% of the individual's time for coordination.

4.2.6 - Summary of Comparable Biosolids Land Application Programs

The following Table 4-5 summarizes data from a variety of existing land application facilities across the country. These operations represent various sizes and technologies, and the data shows the costs associated with the operations.

**TABLE 4-5
LAND APPLICATION FACILITIES**

Name/Location	BioGro Kern and Riverside Co., CA	Environmental Protection and Improvement Company	Ag-Tech Yuma, Arizona	MERCO	McCarthy Farms/Black & Veatch Kings County, CA
Primary Clients	City of Los Angeles Board of Public Works	Bergen County, New Jersey	LA County, Orange County, City of Escondido, City of Yuma	New York City, NY	LA County Sanitation District
Contact	Brian True	James Lauria (201) 807-8689	Kenny Evans (602) 726-3033	Mike Quinn (718) 595-5043	Jon Hay (714) 753-0500
Size	50 - 100 DT/day	150 DT/day lime stabilized material	120 DT/day	50 DT/day (designed for 125DT)	250 DT/day
O&M Costs	\$20 - 33/DT	N/A	\$29/DT	N/A	Estimate quantity, cost, \$20-30/DT
% Solids Sludge	24%	50%	20-24%	28%	26%
Contract Fee (\$/DT)	\$108-166/DT	\$82/DT	\$120-160/DT	N/A	\$30/DT (haul and apply)
Gross Annual Income (\$/yr)	\$2.8-4.4 million	\$4.5 million	\$5.3 - 7.0 million	\$12.4 million	\$2.7 million
Operator	BioGro	Environmental Protection and Improvement Company	Ag-Tech	MERCO	Black & Veatch
System	Land application	Land Application in NY, NH; landfill cover in PA	Land application, subsurface injection	Land application, Range land	Land application
Sludge Class	Class A	Class A	Class A	Class B	Class B
Disposal Arrangements	Other contracts available	Contractor required to take 100%	Other contracts available	N/A	Landfill, Alternative reuse option
Contract Start Date	1989	1995	1988	June 1992	1994
Contract Term	3 years with 2-3 year extension options	5 years with EPIC; contracted with BioGro for 2000-2010.	3 years with 2-3 year extension options	6 years with 5 year renewal option	2 - 3 years
Comments	Dicing and subsurface injection	Contractor required to have beneficial reuse options in 4 states.	Subsurface injections at 8% solids		

NA - Not Available

4.3 - OVERVIEW OF COMPOSTING TECHNOLOGIES

Composting is a biological conversion process where the organic constituents of wastes are rapidly decomposed under controlled aerobic conditions. Controlled conditions allow for elevation and subsequent decrease in temperature as a result of the growth of thermophilic microbes in the compost pile with subsequent die-off of organisms and pathogen kill. The process results in a highly stable product suitable for use as a soil amendment in horticultural and agricultural practices and can be suitable for distribution to the public, landscapers, and other horticultural and nursery users. A variety of composting technologies are available today which can convert dewatered sludge or biosolids to a stable soil-like conditioner that is suitable for land application. These technologies can be classified under three general categories:

- Windrow
- Aerated static pile
- In-vessel

The common elements, as well as the differences, of each of these systems are discussed in the following sections.

4.3.1 - Process Overview

Composting uses micro-organisms to decompose volatile organic matter into a stabilized organic residue with a release of carbon dioxide and water. Energy (heat) generated due to the decomposition of solids promotes the evaporation of water and kills pathogens in the biosolids. Energy production depends on a number of factors like pH, carbon to nitrogen ratio of the mixture, type of biosolids processed (aerobic or anaerobic), and the type of mixture of bulking agent. The following key parameters are important for successful composting:

- Aeration
- Moisture content
- Carbon to nitrogen ratio

Depending on the characteristics of the feed substrate, temperatures during the composting process can reach such high levels that biological activity may actually be impeded. As a result, air circulation is not only essential to meet oxygen demands, but also to remove heat, water, and moisture produced due to biological activity. The required oxygen concentration of 5 to 20

percent throughout the pile can be met by several different methods. In aerated static piles, air is drawn or pushed through the pile using low pressure, high volume blowers, and an immersed piping system. In windrow systems, the piles are periodically turned or agitated to expose new surfaces and renew the entrained air supply. Proprietary in-vessel systems use either one or both of these concepts in their process.

In order to facilitate the movement of air through the composting mass, the dewatered biosolids are mixed with a bulking agent prior to aeration. A bulking agent is an organic or inorganic material of suitable size to provide structural support and maintain air space when added to the wet biosolids. It also absorbs moisture and can provide an energy source for the microorganisms. The biosolids bulking agent mix should have a porosity of at least 40 percent to avoid the formation of biosolids balls. Air circulation also minimizes odor problems associated with anaerobic composting. A second important parameter is the moisture level in the pile. Moisture levels below 40 percent restrict microbial activity. If the moisture level exceeds 60 percent, the porosity in the pile is decreased and the required oxygen cannot reach the center of the pile. This condition not only reduces the rate of decomposition, it also leads to the formation of odor forming compounds in the center of the pile. The quality of finished compost is also affected. The sources of moisture include the incoming sludge, bulking agent, and inclement weather (if outdoors). Moisture in the final product should be no more than 40 to 50 percent to successfully market the product.

A third requirement is the carbon to nitrogen ratio of the mixture undergoing composting. The desirable carbon to nitrogen ratio ranges from 25 to 30 units of carbon for every unit of nitrogen. Carbon values in excess of 30 tend to slow the process and decrease temperatures. With low carbon to nitrogen ratios, excessive ammonia may be released and the nitrogen content of the compost is reduced.

Temperature also plays an important role in producing a stabilized, acceptable product. Optimum temperatures of about 50°C result in accelerated stabilization and removal of moisture with minimal odor production. Optimum temperatures must be higher to kill pathogens and meet U.S. EPA time/temperature requirements for a process to further reduce pathogens. Higher

temperatures (greater than 60°C) can produce a wet and not well stabilized compost due to decrease in the population of aerobic microorganisms.

4.3.2 - Bulking Agents

Also known as amendments, bulking agents are organic or inorganic materials added to biosolids to condition them for composting. All three types of composting systems previously mentioned require a bulking agent to manage biosolids. Selection of bulking agents is important to the performance and cost of composting systems. Bulking agents meet the following needs of composting systems:

- Adjust the moisture content
- Provide porosity for air circulation
- Add carbon to adjust the carbon to nitrogen ratio
- Provide supplemental organic content
- Dilute heavy metal content of biosolids

To be suitable as a bulking agent the material should be relatively dry (more than 55 percent solids), uniform in particle size (0.75 to 2.0 inches, depending on the type of system) and free of inclusions, such as metal and plastic. Properties of the biosolids determine the type and suitability of a bulking agent. A wide variety of materials may be considered when selecting a bulking agent. The following materials are commonly used or have been tested in biosolids composting facilities in the United States.

- Wood chips suitable for pulp mills
- Sawdust
- Whole tree chips
- Ground-up recycled lumber
- Leaves and brush
- Straw
- Shredded rubber tires
- Shredded paper
- Rice hulls

Bulking agent selection depends on year-round availability of a uniform material. This uniformity applies to moisture content, as well as product texture. Yard wastes may require shredding to facilitate the feeding and mixing operations. Agricultural wastes may be available on a seasonal basis only. To insure an adequate supply of seasonal type bulking agents for a

year-round operation, a storage facility must be provided. Small particle bulking agents, such as sawdust, peanut hulls, straw, peat, and rice hulls will be difficult to screen-out of the final product. This will require new material for each cycle, whereas shredded tires or wood chips can be screened out and reused. If the bulking agent is not screened out, the volume of compost produced per dry ton of biosolids may be two to three times greater than with screening, which is a very important consideration. The compost will also be more dilute with respect to both nutrients and contaminants if not screened. Bulking agent selection is, therefore, influenced by the market for the compost.

Finally, the cost varies greatly for bulking agents. Wood chips are in wide demand as a fuel, mulch, and feedstock for papermills and the composting facility must, therefore, pay competitive market prices. Materials such as yard wastes may be available at little cost. Some composting facilities charge a disposal fee to landscape contractors wishing to dispose of such wastes. Processing yard wastes by grinding becomes a necessary step in the overall process where this is practiced. Transportation costs will also contribute to the final price of bulking agents, since the source of sawdust and wood chips may be remote from the point of use.

4.3.3 - Composting Systems

Three general types of composting systems are utilized for biosolids composting. Windrow composting takes place when the biosolids/bulking agent mixture is deposited in long, four to six-foot deep rows which are periodically turned over by mechanical turning equipment to expose the mixture to ambient oxygen. Windrow systems, by nature, operate at an oxygen deficit within the pile in between pile turnings, especially in the first one to two weeks of the process when biological activity is the greatest. This situation can slow the composting process slightly. It also creates a greater potential for malodor generation and release during turning events as compared to the other systems. Static pile systems utilize deeper (six to 12 feet) piles to compost the mixture of biosolids and bulking agent. These piles are aerated by forced ventilation systems installed under the piles. This aeration system maintains the necessary oxygen level and controls temperature throughout the pile. In-vessel systems carry out the composting operation in environmentally controlled vessels or bins. In-vessel systems may be

classified by material flow direction as vertical or horizontal. Further classification separates static or plug flow types from the agitated bed systems. The enclosed nature of in-vessel systems can have better public and operator acceptance due to aesthetics and the potential for better odor control. Recent trends to enclose aerated static pile facilities can accomplish the same objective.

A generalized flow diagram of a composting process is shown in Figure 4-1. Dewatered biosolids are mixed with a bulking agent. The mixture is aerated for 15 to 28 days by periodic turning, forced aeration, or a combination of both. Residence time for this composting stage varies with the type of biosolids mixture and regulatory requirements. Bulking agent recovered by screening or finished compost may be recycled. Compost cannot be screened if the moisture content exceeds 45 to 50 percent. Some composting facilities include a drying stage ahead of screening. Screening also helps produce a finely graded product which is more marketable than the compost mixed with wood chips. The compost is cured for an additional 30 days by making piles eight to ten feet high. In some systems, air is introduced in the curing stage to maintain an aerobic environment and to promote drying. Unscreened or screened compost can be cured, but curing screened compost requires less area. Tables 4-6 through 4-8 summarize advantages and disadvantages associated with each composting system.

FIGURE 4-1 COMPOSTING GENERALIZED FLOW DIAGRAM

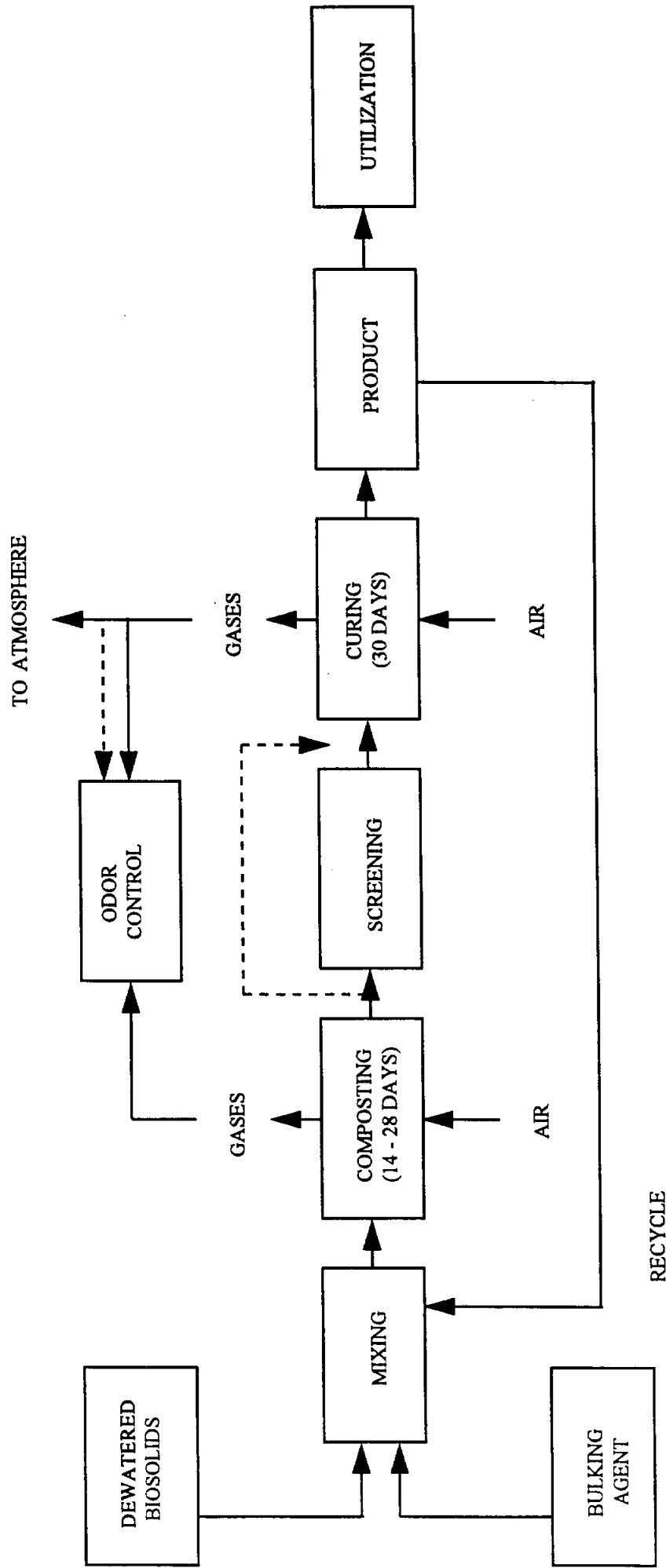

TABLE 4-6

ADVANTAGES AND DISADVANTAGES OF WINDROW COMPOSTING

ADVANTAGES	DISADVANTAGES
<ul style="list-style-type: none">• Simple treatment process to install and operate• Adaptable to various bulking agents• Flexibility to handle changing feed conditions• Turning action promotes good drying which facilitates screening• Relatively low capital investment (if outdoors)• Turning action homogenizes compost• Turning action results in some size reduction• Good ability to maintain throughput• Dilution of biosolids contaminants	<ul style="list-style-type: none">• Requires largest area per ton of biosolids processed• Odor "peaks" are released during each pile turning operation• Requires careful monitoring to insure temperature levels throughout are adequate for pathogen destruction• Employs high maintenance equipment• May require disinfection to destroy pathogens• Large quantity of end product per dry ton processed• Operators are exposed to composting material• Effectiveness is subject to weather conditions (if outdoors)

TABLE 4-7
ADVANTAGES AND DISADVANTAGES OF AERATED STATIC PILE
COMPOSTING

ADVANTAGES	DISADVANTAGES
<ul style="list-style-type: none"> • Relatively low capital investment (if outdoors) • Simple treatment process to install and operate • Effective pathogen destruction • Better odor control than windrow systems • Relatively easy to enclose • Adaptable to various bulking agents • Shortened processing time • Good control of temperature and aerobic conditions • Good ability to maintain throughput • Dilution of biosolids contaminants 	<ul style="list-style-type: none"> • Requires significant land area • Effectiveness is subject to weather conditions (if outdoors) • Odors can be more difficult to control than in some in-vessel systems (unless indoors) • Large quantity of end product per dry ton of biosolids processed • More labor-intensive than conventional windrow technology • Operators are exposed to composting material

TABLE 4-8
ADVANTAGES AND DISADVANTAGES OF
AGITATED BED COMPOSTING SYSTEMS

IN-VESSEL TECHNOLOGY	ADVANTAGES	DISADVANTAGES
<ul style="list-style-type: none"> • Horizontal agitated bed reactor 	<ul style="list-style-type: none"> • Can accommodate small particle size bulking agents • Repeated mixing action to eliminate dead spots and provide more uniform porosity • Flexibility in bin loading and agitation schedule permits remixing and modification of bulking agent to address variations in biosolids moisture • Automated temperature feedback aeration controls 	<ul style="list-style-type: none"> • Single outfeed device with some flexibility • Potentially dusty working environment • Fixed volume reactors. Limited capacity to handle changing feed conditions • Operators exposed to composting material surfaces for open bin type • Land area as great as with static pile

4.3.3.1 - Windrow Composting Systems

Windrow composting systems are non-proprietary and can be designed in a variety of configurations. Windrow composting of biosolids starts with the mixing operation, where biosolids are mixed with a dry compost or a bulking agent to reduce moisture and increase the structural integrity of the mix. This mixture is piled in long parallel rows or windrows. The size and shape of these rows is dictated by the slump characteristics of the mix and the turning equipment used for the pile aeration. The cross section of the windrow may be trapezoidal or triangular, depending on the characteristics of the mobile equipment used for turning the pile. Figure 4-2 shows a diagram of a typical windrow composting system.

The rows may be positioned over the grating of a submerged aeration system. Such a system is known as the *aerated turned windrow* process. Other windrows may be constructed on open, uncovered pads or under a roof. These rows are periodically turned and agitated by windrow turning devices. Some windrow turning machines straddle the pile and are propelled along the pile axis, while a powered auger digs at this pile base and discharges by conveyor to

FIGURE 4-2

WINDROW COMPOSTING SYSTEM

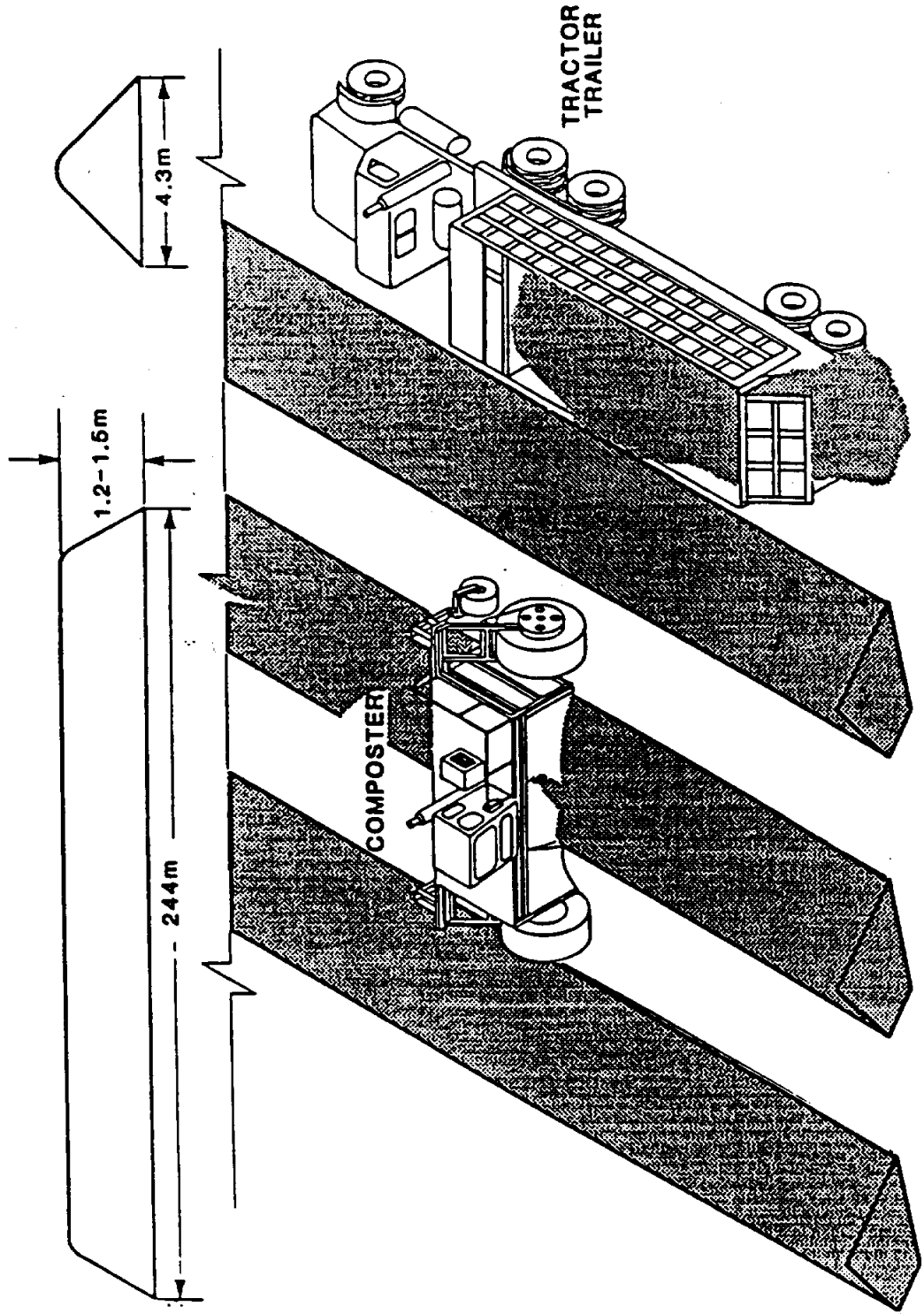

the rear of the machine. Other windrow turning devices are propelled by a tractor which travels down aisles between the piles. An action similar to the straddle machine excavation takes place. Some of these units discharge to the rear while others displace the pile axis sideways to a new position during each pass.

4.3.3.2 - Aerated Static Pile Systems

Aerated static pile systems are also non-proprietary technologies. An aerated static pile system was developed in order to eliminate many of the land and handling requirements of windrow composting as well as contain the odors generated during windrow turning events. The aerated static pile process also begins by mixing the biosolids with a carbonaceous bulking agent. Wood chips are the most commonly used bulking agent. Small to medium sized composting facilities use front end loaders or batch mixing boxes to combine these ingredients. Large scale composting facilities utilize paddle or pugmill mixers or plow mixers which operate in a continuous feed mode. Once the biosolids are thoroughly mixed with the bulking agent, it is deposited on a prepared layer of wood chips or other bulking material. This initial sub-base for the pile consists of a one-foot deep layer of wood chips in which perforated plastic aeration pipes have been immersed. Some systems utilize subsurface duct systems for aeration. This layer of wood chips acts as a diffuser for the air used in aerating the pile. The width of this base varies with the specific design. The biosolids/bulking agent mixture is formed into a six to 12-foot high pile. The front-end loader operator covers this pile with a layer of compost which acts as an insulation layer and an odor scrubber at the surface of the pile. To reduce labor requirements, some aerated pile installations utilize belt conveyor systems to distribute compost and form the piles. The pile remains intact typically for a period of 21 to 28 days during which time microbial action degrades the organic compounds with an accompanying release of energy.

This energy raises the pile temperatures to a level (50°C to 60°C) which eliminates the pathogens present in the biosolids. Since the composting process requires oxygen to digest organic substances, low pressure blowers are connected to the air distribution system. The blowers are used to either force or draw air through the pile. Temperature control can be achieved by varying the time period during which aeration takes place. Temperature feedback

control systems are increasingly common in these type of systems. Daily measurements of the pile temperatures are used by the operator to control the process and assure adequate temperature levels for pathogen destruction. Once the composting period is complete, the compost material is removed from the active area to a curing pad where some additional breakdown and drying will occur. This curing may extend from 30 to 60 days.

The usage of the compost may require further processing steps. In addition, if a reclaimable bulking agent, such as wood chips or rubber tire fragments, is present in the compost, screening will be necessary to reclaim the bulking agent. Wood chip recoveries of 70 to 80 percent (based on initial bulking agent volume) can be obtained in some cases. Most commonly, the compost is screened prior to curing. This reduces the volume of the curing pile and limits the breakdown of the bulking agent. Compost cannot be screened if the moisture content exceeds 45 to 50 percent. An additional drying step with very high rate aeration is sometimes included between composting and screening. Equipment typically used for separating compost and bulking agent in municipal biosolids composting applications includes vibrating deck and trommel screens. Figure 4-3 shows a diagram of a typical static pile composting system.

4.3.3.3 - In-Vessel Composting Systems

In-vessel composting systems follow a route similar to that employed in windrow and aerated static pile systems for mixing the biosolids with a bulking agent to produce the desirable level of moisture, provide a source of carbon, and improve the mix porosity. In-vessel composting systems are proprietary and are offered by a large number of companies. The variety of in-vessel systems available can differ significantly in design and layout offering unique advantages and disadvantages to each system. In-vessel systems can be divided into three general categories which include:

- Vertical reactors
- Horizontal non-agitated reactors
- Horizontal aerated agitated bed reactors

FIGURE 4-3

EXTENDED AERATED STATIC PILE COMPOSTING

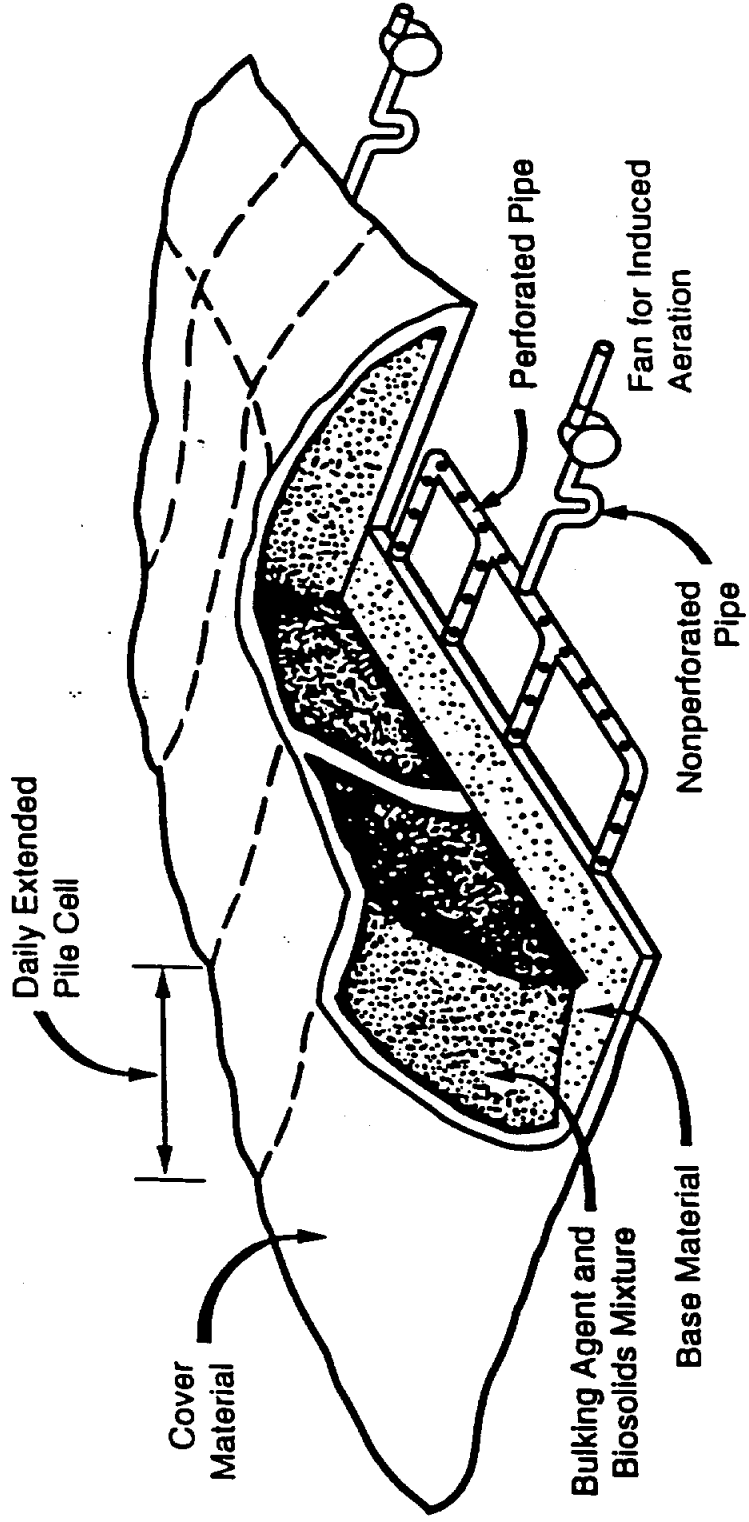

Aerated agitated bed systems are the only in-vessel systems which are addressed as part of this work scope. This is due to their greater success in municipal applications over recent years as compared to other in-vessel systems.

Horizontal aerated agitated bed systems consist of a series of parallel, open top concrete bins loaded at one end and discharging at the other. The bin cross section varies from six to 20 feet wide and six to ten feet deep. The bin length is dependent on the rate of movement and the desired number of days required for the process. Typical bin lengths vary from 100 to 200 feet. The material to be composted is deposited at the feed end of this bin or trough. A mechanical mixing aerating device travels the full length of each bin on a daily basis. As this excavator unit moves down the length of the bin, it digs up and redeposits the full content of the trough and moves it towards the discharge. The daily advance of the compost is usually ten to twelve feet. Each bin is equipped with an automated aeration system which provides oxygen and controls temperature of the bin contents. These controls are usually linked to a computer controller for complete data recording and process control capability. The following are some of the horizontal agitated bed systems:

- Paygro
- OTVD Systems
- International Process Systems (IPS)
- Longwood
- Taulman

Agitating mechanisms and the feed (mix) input point into the reactor vary in these systems. A typical horizontal agitated bed system is shown in Figure 4-4.

4.4 - COMPOSTING TECHNOLOGIES ASSESSMENT

This section of the report summarizes key factors involved in designing and operating composting facilities. Information was gathered through the use of telephone surveys, site visits, and literature review and is described in the following sub-sections. A brief plant description of the facilities surveyed is provided at the end of this section.

FIGURE 4-4

AGITATED BED TYPICAL CONFIGURATION

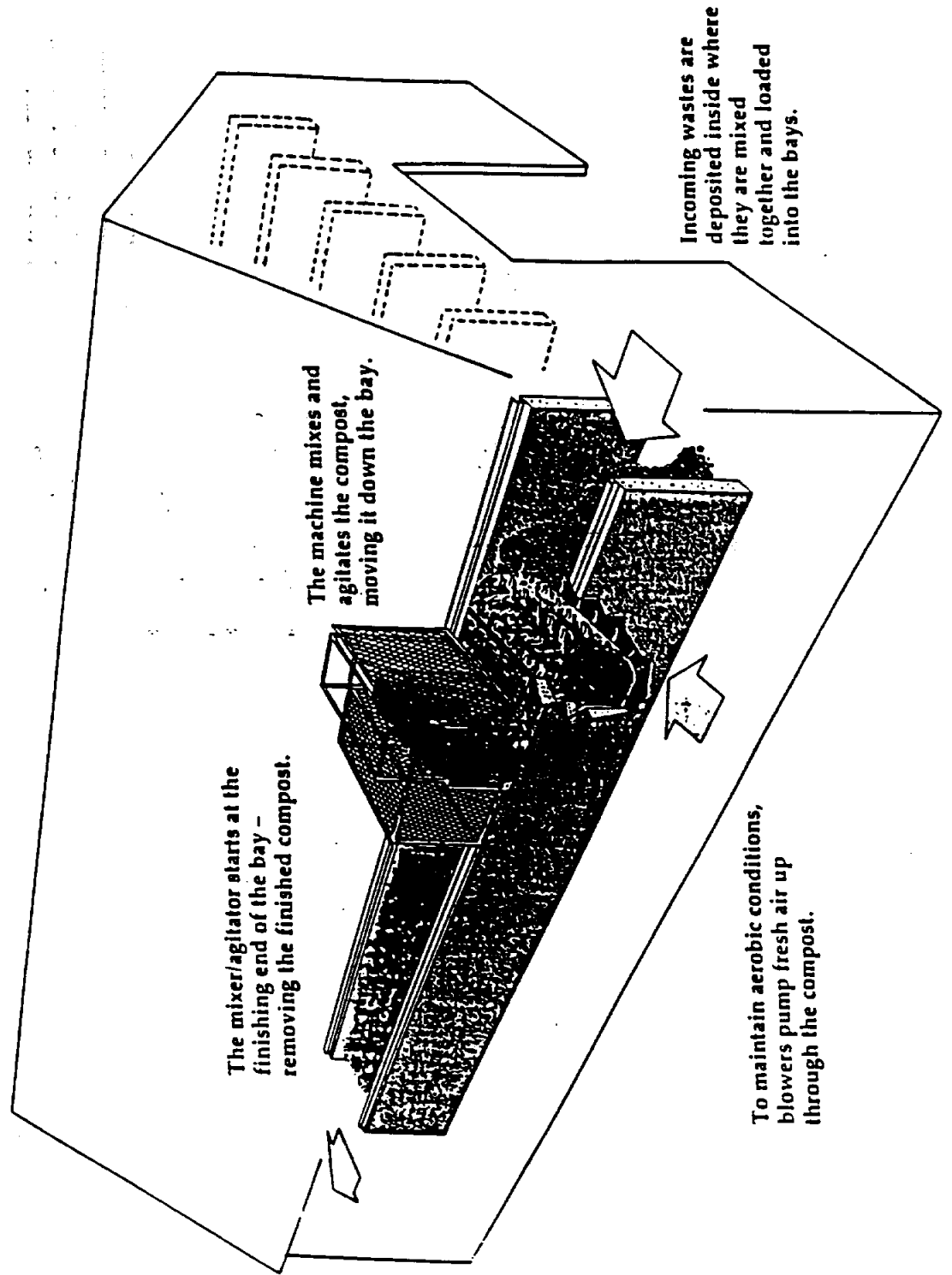

4.4.1 - Area Requirements

Significant variations in the area requirements for a composting facility exists from facility to facility. Exact acreage is difficult to obtain for facilities that adjoin the WWTP's. Other factors effecting facility land requirements include the size of storage areas, leachate collection ponds, the odor control technology utilized, and buffer areas to the site perimeter.

Buffer areas are controlled by facility location. Facilities at WWTP's may require minimal buffering areas above that of the treatment plant, while facilities at remote sites may require 200 or more feet from the processing area to the site perimeter.

In general, the windrow facilities require the most acreage per dry ton, with aerated static pile and aerated agitated bed facilities requiring approximately the same area. The land requirements for each of the technologies is shown in Table 4-9.

**TABLE 4-9
COMPOST FACILITY LAND AREA REQUIREMENTS**

Technology	Range of Area Requirement (Acre per dry ton per day of biosolids capacity)	Average Area Requirements (Acre per dry ton per day of biosolids capacity)
Aerated Agitated Bed	0.39 - 0.56	0.48
Aerated Static Pile	0.27 - 0.54	0.39
Aerated Windrow	0.51 - 0.67	0.59

Land area requirements for aerated agitated bed facilities range from 0.39 to 0.56, with an average of 0.48 acres per dry ton per day of biosolids capacity. Land area requirements for aerated static pile facilities range from 0.27 to 0.54, with an average of 0.39 acres per dry ton per day of biosolids capacity. Land area requirements for aerated and unaerated windrow facilities range from 0.51 to 0.67, with an average of 0.59 acres per dry ton per day of biosolids capacity.

4.4.2 - Site and Utility Requirements

Site and utility requirements vary from facility to facility. For example, facilities located at WWTP's may not require additional site fencing, access roads, security gates, or administrative buildings, while remote facilities may require all of these. Desirable site features for a compost facility include:

- Near biosolids production facility to minimize transport costs
- Access roads capable of handling heavy truck traffic
- Compatible neighboring facilities (i.e., industrial type operations or farm land)
- Minimal site elevation deviations
- Soils adequate to support structures and heavy equipment traffic
- Access to existing utility lines such as water and electricity

Most of these requirements can be satisfied when facilities are located near WWTP's.

As a minimum, water and electricity must be provided to the composting facility. Water is used for several activities including equipment and site washdown, personnel usage, some types of odor control systems, and some composting technologies. Often times a combination of potable water and effluent water are sometimes utilized to meet the water demand and reduce potable water costs.

Most facilities use electrically driven equipment during the composting process. This equipment may include blowers, pumps, materials handling equipment, controls, and lights. In addition, the following utilities may be required:

- Telephone
- Natural gas
- Diesel fuel storage
- Sanitary sewer/septic system
- Truck scales
- Leachate Collection

Telephone access should be provided at the compost site to allow for coordination of materials movement to and from the site and for general information flow. Natural gas may be required for heating of personnel areas and equipment rooms. Diesel fuel storage on-site can normally be accomplished through above-ground storage tanks. Diesel storage will provide the operator flexibility in mobile equipment operations and prevent potential scheduling conflicts with refueling trucks. Sanitary sewer or a septic system will be required for personnel working at the

facility depending on availability of such services at nearby facilities. Truck scales may be required to monitor quantities of materials arriving at and being removed from the facility. Truck scales allow more exact and efficient materials handling recordkeeping, although many facilities monitor material flow by volume. Leachate collection is required for condensate from the composting process as well as runoff from outside storage pads. Several types of treatment are possible to include the use of siltation ponds and discharge to sanitary sewer lines. Many of the utility requirements are site specific, as well as specific to operator preference and budget constraints. Storm water runoff control is also required at compost sites.

4.4.3 - Capital and Operating Costs

A wide variation in capital investment results from site acquisition costs, site preparation costs, technology selected, size of facility, and level of process and odor control utilized. In general, facilities located adjacent to wastewater treatment plants (WWTP's) are less expensive to construct due to less site preparation costs such as utilities and roads. From a technology standpoint, aerated agitated bed facilities are generally the most expensive to construct, followed by aerated static pile facilities, aerated windrow facilities, and then unaerated windrow facilities. The actual capital cost varies widely based on specific facility requirements. To compare facility costs 1996 Means Building Construction Cost Data historical, and city cost indexes were used to compare capital costs from existing facilities to the Austin, Texas area in 1996.

Capital costs for aerated agitated bed facilities range from \$306,000 to \$660,000 per dry ton per day of biosolids capacity, with an average of \$493,000 per dry ton per day of capacity. Capital costs for aerated static pile facilities range from \$223,000 to \$629,000 per dry ton per day of capacity, with an average of \$333,000 per dry ton per day of capacity. Capital costs for windrow facilities range from \$13,000 to \$123,000 per dry ton per day of capacity, with an average of \$68,000 per dry ton per day of capacity.

Operating and maintenance (O&M) costs vary from facility to facility with the two main components being labor and bulking agent. Some facilities accept yard wastes and process the material, while other facilities purchase high quality wood chips. The O&M costs for the aerated agitated bed facilities range from \$109 to \$175, with an average of \$144 per dry ton of biosolids

processed. The O&M costs for aerated static pile facilities range from \$137 to \$214, with an average of \$164 per dry ton of biosolids processed. The O&M costs for windrow facilities range from \$69 to \$125, with an average of \$93 per dry ton of biosolids processed.

4.4.4 - Environmental and Odor Control

The primary environmental concerns regarding operation of biosolids composting facilities is that of surface water runoff from processing areas and odor control. Surface water runoff from active processing areas should be collected and treated to minimize any surface water pollution. Typically, biosolids composting facilities are operated on impervious pads such as clay lined or even asphalted and concrete paved surfaces. Any leachate, condensate or runoff from these process areas should be collected and treated prior to discharge. This is typically done through discharge to sewers or pump and haul operations at remote sites to take in treated water to a permitted wastewater facility. Storm water collection and treatment is typically practiced through the use of siltation ponds from areas where compost and or bulking agents are stored both before and after processing. Roofed areas at composting facilities minimize the amount of surface water runoff which requires collection and treatment. In these cases, the majority of any water from any composting site would be from roof or paved storage areas, thereby requiring only good storm water collection practices.

Odor control from composting facilities is perhaps the most pervasive issue of concern in the industry today. Because of the nature of biosolids and other putrescible materials, odor generation at composting facilities is common. The amount of odor which can be tolerated at composting facilities is impacted by a number of factors such as:

- The type of material being processed
- Quantity of material being processed
- The type of composting technology employed
- The degree to which a composting facility is enclosed
- Buffers surrounding the facility
- Micro-climate near the facility

Odor control at composting facilities involves process adjustment, enclosure, and finally collection and treatment of odorous gases. The natural degradation of organic material will generate sulfur and nitrogenous laden compounds such as dimethyl sulfide, ammonia, and amines in minute quantities. The presence of these compounds at these extremely low concentrations does not pose a health risk. However, these compounds are extremely pervasive even at low concentrations and can be detected and perceived to be highly odorous. For these reasons, many facilities being operated or planned must consider the impact that odors may have on surrounding property owners.

Process adjustments have been somewhat successful in reducing odor generation at composting facilities. Using good operational practices can, indeed, minimize odor generation. However, odor generation will be present even at a very well run and operated composting facility. Odors are typically associated with the wet stages in the composting process. Consequently, many facilities have placed roofs over portions of the composting process to minimize the impact from weather. However, until facilities are enclosed and exhaust gases collected and treated, these odors can still escape from an operating facility and be carried offsite where receptors may notice them. An increasingly common trend, therefore, is to totally enclose composting facilities and to treat off gases through some method of either chemical scrubbing or biofiltration system. Chemical scrubbing utilizes complex chemistries and acidic or caustic chemicals to scrub odorous gases out of an airstream. These systems are expensive to install and operate and require substantial quantities of water and chemicals to operate. Biofiltration is a method whereby odorous gases are treated through a media of organic material such as well stabilized compost and woodchips. The use of biofiltration systems is increasingly common at composting and other facilities for odor control. Biofiltration systems tend to be significantly less costly to operate than a wet chemical scrubbing system. However, they require significantly larger land area than a chemical scrubbing system, and therefore, are used on a site specific basis. Totally enclosed composting facilities which treat off gases in this manner typically have experienced very few odor problems except where fugitive gases continue to be released from some point in the process that is not effectively collected. The primary consideration in looking at odor control is the quantity of material being processed, the location of the site, and the buffer

area around the existing operation which can disperse odors prior to them being carried to a receptor.

In the site selection and design stages of project development, odor modelling can be performed to compare various facility types, layouts, and treatment options and the impact on odors to surrounding neighbors. In this way, non-acceptable scenarios can be screened out and only acceptable scenarios with minimal odor impact can be evaluated and developed. This practice is highly beneficial and recommended for the development of new composting facilities to ensure odor nuisances do not occur.

4.4.5 - Staffing Requirements

Labor is normally a large component of the O&M costs for composting facilities. The number of personnel at a specific facility varies for several reasons. In some cases, the composting facility is totally separate from the WWTP and the operating staff must include a maintenance force whose total assignment rests with the composting operation. Other facilities located near the wastewater treatment facility site share maintenance crews with the treatment facility. Another factor affecting staffing levels at operating facilities is whether the facility was designed for a larger tonnage than that presently being processed. This results in a high ratio of personnel to dry ton of biosolids processed. Table 4-10 shows the range of staffing requirements for the different technologies.

**TABLE 4-10
COMPOST FACILITY STAFFING REQUIREMENTS**

Technology	Staffing Range (persons per dry ton of biosolids capacity)	Staffing Average (persons per dry ton of biosolids capacity)
Aerated Agitated Bed	0.20 - 0.50	0.31
Aerated Static Pile	0.27 - 0.63	0.43
Aerated and Un-aerated Windrow	0.27 - 0.59	0.43

Staffing requirements for aerated agitated bed facilities range from 0.2 to 0.5 persons per dry ton of biosolids capacity, with an average of 0.31. Staffing requirements for aerated static pile facilities range from 0.27 to 0.63 persons per dry ton of biosolids capacity, with an average of 0.43. Staffing requirements for windrow facilities range from 0.27 to 0.59 persons per dry ton of biosolids capacity, with an average of 0.43.

4.4.6 - Summary of Comparable Biosolids Composting Facilities

The following section summarizes data on existing comparable biosolids composting facilities throughout the United States. The technologies summarized include aerated agitated bed facilities, aerated static pile facilities, aerated windrow facilities, and unaerated windrow facilities. Data was obtained from telephone survey, site visits, and a review of the literature. Table 4-11 shows a summary of this evaluation and the data which was obtained.

4.4.6.1 - Aerated Agitated Bed Facilities

Lewiston-Auburn, Maine - The composting facility in Lewiston-Auburn, Maine utilizes the aerated agitated bed process to compost 10 DTPD of 20.5% total solids dewatered municipal biosolids. Composting and mixing occur in a totally enclosed building with ventilation treated through a biofilter. The facility has six composting bays and two agitators. Wood shavings are utilized as the bulking agent. After discharge from the bay, the material is further aerated for final curing. The facility was constructed for \$6.8 million in 1993. Compost operating costs are approximately \$116 per dry ton of biosolids.

State College, Pennsylvania - The composting facility in State College, Pennsylvania utilizes the aerated agitated bed process to compost 10 DTPD of 21% total solids dewatered municipal biosolids. Composting occurs in a totally enclosed building with biofiltration for odor control. The facility has 12 bays and three agitators. Sawdust is utilized as the bulking agent. The facility was constructed for \$6 million in 1992. Compost operating costs are approximately \$161 per dry ton of biosolids.

Lockport, New York - The composting facility in Lockport, New York utilizes the aerated agitated bed process to compost 14 DTPD of 20% total solids dewatered municipal biosolids.

Table 4-11
COMPOST FACILITY SUMMARY

Facility	Design Capacity (DTPD - 5 days per week)	Biosolids %TS	Year On-line	Capital Cost (\$million - start-up year)	Capital Cost (1996 in Austin, TX) \$ million	O&M Cost (\$/DT)	Staff Requirements	Site Area (Acres)
AERATED AGITATED BED								
Lewiston-Auburn, Maine	10	20.5	1993	6.8	6.6	116	2	108
State College, Pennsylvania	10	21	1992	6.0	5.64	161	5	5
Lockport, New York	14	20	1991	5.82	5.20	171	4	---
Merrimack, New Hampshire	15.5	21	1994	5.37	4.74	109	3.5	6
West Palm Beach, Florida	25	12 - 22	1994	13.0	12.86	150 - 175	---	14
AERATED STATIC PILE								
Davenport, Iowa	28	20	1995	8.5	7.59	137	10	15
Philadelphia, Pennsylvania	280	25	1989	77.3	69.3	350*	175	---
Montgomery County, Maryland	80	20	1988	46.54	50.3	325*	47	---
Blue Plains, Washington, D.C.	55	20	1989	12.08	12.27	214	16	15
Harrisonburg, Virginia	5.5	23	1995	1.51	1.61	140	1.5	2
AERATED WINDROW								
Denver, Colorado	147	20	1986	17.0	18.13	---	40	75
Upper Occoquan, Virginia	15	22	1991	---	---	---	---	---
UNAEERATED WINDROW								
Belton, Texas	2.4	15.5	1990	---	---	69	2	---
San Joaquin, California	120	24	1990	1.95	1.60	108 - 125	---	80

*Includes dewatering costs

Composting occurs in a totally enclosed building with ventilation treated through a biofilter. The facility has 12 bays and three agitators. Wood chips are utilized as the bulking agent. The facility was constructed for \$5.82 million in 1991. Compost operating costs are approximately \$171 per dry ton of biosolids.

Merrimack, New Hampshire - The composting facility in Merrimack, New Hampshire utilizes the aerated agitated bed process to compost 15.5 DTPD of 21% total solids dewatered municipal biosolids. Composting occurs in a totally enclosed building with ventilation through a biofilter. The facility has 15 bays and three agitators. The facility was constructed for \$5.37 million in 1994. Compost operating costs are approximately \$109 per dry ton of biosolids.

West Palm Beach, Florida - The composting facility in West Palm Beach, Florida utilizes the aerated agitated bed process to compost 25 DTPD of 12% to 22% total solids dewatered municipal biosolids. In 1991, four bays were constructed on a covered pad as a pilot project. In 1994, an additional 32 bays were added to increase capacity to full-scale. Composting occurs in a totally enclosed building with ventilation through biofilter. Yard wastes are processed at the facility and used as the primary bulking agent. The facility has a total of 36 bays and nine agitators. The 32 bay facility expansion was constructed for \$13.0 million in 1994. Compost operating costs are approximately \$150 to \$175 per dry ton of biosolids.

4.4.6.2 - Aerated Static Pile Facilities

Davenport, Iowa - The composting facility in Davenport, Iowa utilizes the aerated static pile process to compost 28 DTPD of 20% total solids dewatered municipal biosolids. The mixing and composting areas are totally enclosed with odor control of all building ventilation and process gas through biofiltration. The screening, curing, and bulking agent storage areas are covered. The facility utilizes a mobile grinder to process yard wastes, combined with wood chips and shredded tires, for use as a bulking agent. The facility was constructed for \$8.2 million in 1995. Compost operating costs for composting are approximately \$137 per dry ton of biosolids.

Philadelphia, Pennsylvania - The composting facility in Philadelphia, Pennsylvania utilizes the aerated static pile process to compost 280 DTPD of 25% total solids dewatered municipal biosolids. The mixing area is totally enclosed. Composting and screening occur on

an open pad. Curing and product storage are on a covered pad. The facility was constructed in 1989 at a cost of \$77.3 million. The operating costs are \$350 per dry ton of biosolids, which includes dewatering.

Montgomery County, Maryland - The composting facility in Montgomery County, Maryland utilizes the aerated static pile process to compost 80 DTPD of 20% total solids dewatered municipal biosolids. The biosolids are mixed with wood chips and composted in a totally enclosed building. The compost process gas is collected and treated through a chemical scrubber system. Screening and curing is performed in a totally enclosed building. The facility was constructed in 1988 at a cost of \$46.5 million. Compost operating costs are approximately \$325 per dry ton, which includes dewatering.

Blue Plains, Washington, D.C. - The composting facility in Washington, D.C. utilizes the aerated static pile process to compost 55 DTPD of 20% total solids dewatered municipal biosolids. Composting occurs on a covered pad and no active odor control is performed. Wood chips are utilized as the bulking agent. The facility was constructed at a cost of \$12.1 million. Compost operating costs are approximately \$214 per dry ton.

Harrisonburg-Rockingham Regional Sewer Authority (HRRSA), Virginia - The HRRSA composting facility located in Mount Crawford, Virginia utilizes the aerated static pile process to compost 5.5 DTPD of 23% dewatered municipal biosolids. The mixing, composting, screening, and curing operations are performed on a covered pad. The compost process gasses are collected and treated through biofiltration. Wood chips are utilized as the bulking agent. The facility was constructed in 1995 at a cost of \$1.51 million. Compost operating costs are estimated to be \$140 per dry ton.

4.4.6.3 - Unaerated Windrow Facilities

Brazos River Authority, Belton, Texas - The Brazos River Authority composting facility began operations in 1990 utilizing the unaerated windrow process to compost 3.4 DTPD of 15.5% total solids dewatered municipal biosolids. The aerated biosolids were mixed with wood chips and wood shavings and placed in windrows. The windrows were located on a covered pad. In 1994, the facility converted operations to an aerated static pile/windrow combination process

to reduce odor emissions. Operating costs were estimated to be \$69 per dry ton prior to converting operation to an aerated static pile/windrow combination process.

San Joaquin, California - The Cities of Los Angeles, Fresno, and Pismo Beach transport biosolids and yard waste to the San Joaquin Composting Facility located near Lost Hills, California. The facility utilizes the unaerated windrow process to compost 120 DTPD of 24% total solids dewatered municipal biosolids. Yard wastes are used as the primary bulking agent and finished compost is sold in both bag and bulk. The windrows are constructed on an open pad. The facility was constructed in 1990 for a capital cost of \$1.95 million. Operating costs for the facility are estimated to range from \$108 to \$125 per dry ton of material composted.

4.4.6.4 - Aerated Windrow Facilities

Denver, Colorado - The Denver, Colorado composting facility began operations in 1986 utilizing the aerated windrow process. The facility was designed to compost 147DTPD of 20% total solids dewatered municipal biosolids. The dewatered biosolids were mixed with wood chips and/or sawdust and placed in windrows located on a covered pad. The facility experienced odor problems and currently operates at significantly less than the design capacity. The facility was constructed in 1986 for a capital cost of \$17.0 million.

Upper Occoquan, Virginia - The composting facility located in Upper Occoquan, Virginia utilizes the aerated windrow process to compost 15 DTPD of 22% total solids dewatered municipal biosolids. The dewatered biosolids are mixed with finished compost and placed in windrows over a straw aeration plenum. The facility was constructed in 1991.

4.5 - COMPARISON OF LAND APPLICATION VS. COMPOSTING

Table 4-12 summarizes the advantages and disadvantages of land application vs. composting of biosolids. The primary difference between the technologies is that land application requires minimal capital investment, is a simple, low-cost alternative, and can be implemented in a very short time frame. Composting, on the other hand, requires much less land area than land application and can produce a product which has multiple uses. Composting has the added benefit of processing other potential waste material such as yard waste since it is required as a

bulking agent for dewatered biosolids. Another clear advantage of land application for those facilities which do not have a form of dewatering is that land application can be conducted on a liquid biosolids material. Composting, on the other hand, requires that a dewatering or drying bed operation be in existence in order for a cost effective program to result. Composting can be accomplished year round, whereas land application is dependent on fitting in with agricultural demands and weather factors. Finally, the odors associated with biosolids can be controlled with composting but can be problematic with land spreading if neighbors are close to the application fields. Some combination of these types of programs is commonly practiced at many facilities to allow flexibility for changing regulations, changing weather conditions, and other pressures as they develop. Chapter 6 of this report discusses the rationale for the recommended programs which will be compared on a cost basis.

TABLE 4-12

ADVANTAGES AND DISADVANTAGES OF LAND APPLICATION VS. COMPOSTING
DIRECT LAND APPLICATION **COMPOSTING**

ADVANTAGES	DISADVANTAGES	ADVANTAGES	DISADVANTAGES
<ul style="list-style-type: none"> • Simple alternative • Low cost alternative • Does not require dewatering of biosolids • Maintains nutrients in biosolids 	<ul style="list-style-type: none"> • Significant land area requirements • Potential permitting/monitoring of multiple sites • Potentially affected by weather • Transportation intensive • Potential odor impacts • Significant public education/Public concern over multiple sites • No elimination of pathogens • Dilution of contaminants not possible • No reduction in volume • Impacted by crop requirements, therefore need storage either in the field or at treatment plant 	<ul style="list-style-type: none"> • Simple technology • Versatile, aesthetically pleasing product • Eliminates pathogens • Dilution of contaminants possible 	<ul style="list-style-type: none"> • Labor, material, and transporation intensive • No reduction in volume (1 Dry Ton biosolids = 5 - 6 cubic yards product) • Odor production may require enclosures and treatment

5.0 - MARKET RESEARCH

The market research for the Travis and Williamson County Biosolids Study includes three issues:

- Regional Markets for Compost
- Potential Sources of Bulking Agent for Composting
- Land Resources for Land Application or Composting

The following sections address these issues.

5.1 - LCRA BIOSOLIDS COMPOST MARKETING RESEARCH

In order to better understand the marketability and the parameters necessary to distribute a LCRA produced biosolids compost, preliminary market research was completed by E&A Environmental Consultants, Inc. (E&A). The goal of the preliminary market research was to obtain relevant data regarding planning and implementing a compost marketing program in the Travis and Williamson County areas. Through telephone surveys, information was obtained regarding compost end use, seasonality of use, annual demand, quality requirements, and pricing information. Market segments contacted during the study include landscapers, nurserymen (wholesale growers), garden centers (retail nurseries), topsoil dealers, and landscape materials suppliers. In order to estimate current compost demand in the greater Austin area, 15% (minimum) of the firms within each individual market segment were contacted. This enabled us to complete a quantitative analysis which is statistically defensible.

The Austin, Texas area is home to a very strong landscape/nursery industry which has become well-acquainted with the use of organic soil amendments. This is likely due to the lack of natural rainfall and the poor quality of local soils. The soils were often described as sandy, loamy, or rocky, being low in organic matter and typically alkaline (limestone based).

5.1.2 - Market Segments

During market research, four primary markets were investigated to obtain both qualitative and quantitative market information. These four market areas are landscapers and lawn care (landscapers), retail nurseries or garden centers (garden centers), wholesale nurseries (growers), and topsoil dealers and commercial product wholesalers (landscape materials suppliers).

Information specific to each of the four market segments will be described in the following sections.

5.1.2.1 - Landscapers

The landscaping industry in the Austin area is thriving and the use of soil amendments in various applications is very popular. Composts produced from various agricultural and urban by-products have been avidly used in both bulk and bagged form. Of the landscapers interviewed, 89% (31 of 35) are currently using compost to some degree. Approximately half of the landscapers using compost are using substantial amounts on a yearly basis (from fifty to several thousand cubic yards). Although some compost is being used in turf establishment, the majority of product is being used as turf topdressing in established turf areas and in planting bed establishment. The compost is either applied to the native soil and incorporated or is being blended with other materials to produce a high organic content garden soil. Compost products produced from cow and turkey manure, biosolids, mushroom soil, and cotton burrs are the most popular products locally available. Compost is marketed to the landscape industry directly from compost manufacturers and through landscape material suppliers and garden centers. Several of the larger compost suppliers in the Travis and Williamson County area can be found in Table 5-3. Compost products are being sold for between \$7 and \$33.50 per cubic yard, picked up. Garden Ville of Austin and Whittlesey's Landscape Supply appear to be the largest local distributors of compost products as well as soil blends. Although we estimate that over 50,000 cubic yards of compost is marketed locally within the landscape industry, it is likely that a much greater amount is distributed as a component in manufactured soil blends.

There is wide acceptance of compost use in the landscape industry and there appears to be little phobia toward the use of biosolids products. However, several individuals stated they would not suggest a biosolids product be used where food crops are grown. Several comments suggest that Dillo Dirt is the product of choice for use as a turf topdressing. It should be reiterated that although a large percentage of the compost marketed is used in garden bed preparation, the majority of landscapers preferred to use a pre-blended material so soil

incorporation does not have to be completed at the jobsite. Landscapers are using compost products throughout the year, with peak seasons being the spring and the fall.

Many landscapers stated that they prefer compost products which are rich in organic matter, consistent in nature, well-composted/cured (not hot), rich in nutrition, and possessing no clumps, objectionable odors, or weed seeds. Some landscapers simply stated that they would use any product that was specifically specified on a project or that the customer requests. Landscapers who use the compost for topdressing wanted to make sure that it was fine and somewhat dry for ease of spreading.

5.1.2.2 - Growers

Local wholesale nurseries exist which produce nursery products in containers and in field production. There are also several large nursery wholesalers who stock and resell plant materials but do not grow them. It appears that little, if any, compost is being used in the production of nursery crops in the Austin area and little interest in its use currently exists. Most of the growers are utilizing pre-made planting media to grow their crops and, therefore, do not have the opportunity to use compost. Some, however, do produce their own blend on-site and could be compost users in the future. Currently, pre-made growing media are being marketed for between \$20 and \$50 per cubic yard, delivered. For all intents and purposes, consider the current market for compost use among growers as zero.

5.1.2.3 - Garden Centers

Within the Austin landscape/nursery sector, there is a strong garden center industry. Most garden centers distribute plant materials, gardening information and tools, as well as bagged and sometimes bulk products. Many garden centers also sell products to industry professionals, usually at a discounted price. Of the garden centers contacted during our survey, approximately 84% offer compost for resale in either bagged or bulk form. Of these, 25% carry both bagged and bulk compost, while approximately 56% carry only bagged and approximately 19% carry only bulk compost. The types of compost being distributed include mushroom soil, cotton burr, manure, and biosolids compost. Tables 5-1 and 5-2 provide detailed pricing information on bulk

and bagged compost products marketed through local garden centers. Compost products are being distributed at a picked-up price of between \$18 and \$34.95 per cubic yard, while bagged prices vary widely based on volume packaged. Great acceptance exists for the use and resale of compost through the garden centers. The majority see a great need in organically enriching the soil before establishing any plant materials. It is estimated that over 23,000 cubic yards of compost are currently marketed on a yearly basis through the Austin area garden centers in bulk form alone. It is estimated that if bagged compost and compost contained in soil blends were included, then the volume estimate would increase by 50% to 100% on an annual basis.

TABLE 5-1
RETAIL COMPOST PRICES¹ - BULK
(per cubic yard)

Compost Product / Feedstock	Price (Range)
Back-to-Earth (cotton burr)	\$21 - \$33
Bert's Dirts Manure Compost	\$28
Cotton Burr (from Amarillo)	\$27 - \$30
Cow manure (Geo Growers)	\$20 - \$33.50
Dillo Dirt (biosolids)	\$18 - \$22
Garden Compost ² (unknown)	\$32
Garden-Ville Compost (various ingredients)	\$32
Humisoil (manure/yard debris)	\$26
Living Earth Compost (Houston)	\$21
Manure (unspecified)	\$20 - \$24
Mushroom soil	\$21 - \$28
Turkey manure (Geo Growers)	\$32.12 - \$34.95
Whittlesey's Organic Compost (various ingredients)	\$30

Notes: ¹All prices picked up at retail location
²Product produced by AAA Grass and Landscape

TABLE 5-2
RETAIL COMPOST PRICES¹ - BAGGED

Compost Product / Feedstock	Size	Price (Range)
Back-to-Earth (cotton burr)	3 cubic feet	\$3.80 - \$7.59
Back-to-Earth (cotton burr)	5 gallons	\$1.35 ²
Cow manure (various brands)	40 pounds	\$1.69 ³ - \$2.49
Dillo Dirt (biosolids)	1 cubic foot	\$1.99 ³ - \$6.99
Earth Perfect Compost	1 cubic foot	\$5.49
Garden•Ville Compost (various ingredients)	80 quarts/20 gallons	\$10.75 - \$10.95
Garden•Ville Compost (various ingredients)	1 cubic foot	\$4.49 - \$4.99
Garden•Ville Compost (various ingredients)	5 gallons	\$1.35 ²
Turkey manure	80 quarts	\$10.95
Turkey manure	5 gallons	\$1.35 ²
Whittlesey's Organic Compost (various ingredients)	1 cubic foot	\$1.99 ³

Notes: ¹All prices are picked up at retail location
²All bag your own prices from Garden•Ville
³Pre-bagged by Whittlesey

5.1.2.4 - Landscape Materials Suppliers

The last market segment surveyed in this preliminary study was landscape materials suppliers. Several of these firms concentrate primarily on bagged products and tools, while others concentrate on bulk products. Within this category, the most important potential compost end users are topsoil dealers and bulk material yards and blenders. Both of these types of firms typically sell to both retail and wholesale customers, but to a large extent, the bulk material dealers primarily deal with the professional landscape industry. It has become obvious through research that the use of bulk soil mixes, which are modified and upgraded using compost, are extremely popular and commonly used materials throughout Austin. Although it is difficult to determine at this point, it is probable that more compost is used in the Austin area through the production of topsoil blends than is marketed unblended or straight to the landscape/nursery industry. Of the 15 companies contacted, approximately 47% (7 of 15) are selling or using compost in their operations. As the landscape industry has described, product is used on a year-round basis with peak usage in the spring and fall.

Preliminary estimates suggest that over 100,000 cubic yards of compost are used on an annual basis in this market segment. Wholesale compost prices range from \$7 to \$33.50 per cubic yard, picked up. Although several of these firms produce their own compost, the majority have firms which supply them with compost for resale and use. It should also be noted that several of these firms market more than one type of compost, along with several types of soil blends. Some also carry bagged compost products. Data in Table 5-3 outlines the compost types available through local bulk material yards and compost producers, as well as applicable wholesale pricing information. Wholesale pricing is only available to industry professionals.

TABLE 5-3
WHOLESALE COMPOST PRICES - BULK

	Feedstock (Price) ^a	Volume	Location	Other
Whittlesey Landscape Supply ^b	composted cow manure - \$17/yd ³ organic compost - \$25/yd ³ (manure, cotton seed hulls, wheat straw, etc) Dillo Dirt - \$15/yd ³	20,000/yd ³	Austin	Produces his own compost and distributes others, large soil blending business (probably 100,000 cubic yards or more per year)
Garden-Ville of Austin ^b	cotton burr compost - \$24.75/yd ³ turkey manure compost - \$27.50/yd ³ Dillo Dirt - \$15.50/yd ³	N/A	Austin	Distribute compost, main business in producing soil blends, probably largest firm in area, may start composting manure
Geo Growers	turkey manure compost - \$28.90/yd ³ dairy manure compost - \$33.50/yd ³	N/A	Austin	Distributes compost, main business is producing soil blends with compost
Hornsby Bend Compost Facility	biosolids compost - \$7/yd ³ to vendors and \$200 vendor fee	16,000-18,000 yd ³ (estimated for 1996)	Austin	Vendors sell to end users and through resellers, end users usually pay \$15-\$20/yd ³
Bert's Dirts	manure compost - \$28/yd ³	N/A	Austin	Claims to have been composting for 40 years, uses in soil blends also
Austin Landscape Supplies	manure compost - \$22/yd ³ Dillo Dirt	5,000-10,000 yd ³	Austin	Distributes compost, produces soil blends with compost

Notes: ^aAll quoted prices are wholesale, picked up.
^bPrice lists in Appendix
N/A - Not Available

Several landscape material wholesalers are bagging their own products, as well as products like Dillo Dirt for resale. Several of these firms, like several landscapers, consider Dillo Dirt or biosolids compost as an inexpensive but inferior alternative to some of the

agricultural by-product based composts currently available. Great opportunity lies in this market segment to resell LCRA compost on a large-scale basis, as well as use it in soil blends.

5.1.3 - Current Estimated Compost Demand

The preliminary quantitative data obtained during the market study illustrates a large and thriving compost market in the Austin area. Table 5-4 outlines a conservative estimate of just over 180,000 cubic yards of compost used on an annual basis, primarily purchased and resold in bulk form. This is considered a conservative estimate since it does not include the compost used and resold in bagged form or all of the compost contained in the production of soil blends. However, it could be argued that the compost use estimates developed for the landscape material suppliers represent the majority of that product. Regardless, considering these facts, as well as others, it is conceivable that the actual volume of compost used on an annual basis is closer to 300,000 cubic yards.

Current trends and attitudes observed during the market study suggest that compost use will continue to increase in the Austin area. It is also obvious that many of the firms utilizing compost are cognizant of quality issues and are willing to pay considerably for quality products.

TABLE 5-4

**PRELIMINARY CURRENT COMPOST USE ESTIMATES
FOR THE TRAVIS AND WILLIAMSON COUNTY AREA**

Market Segment	Annual Volume (cubic yards)
Garden Centers	23,358 ¹
Landscapers	53,000
Nurseries	0
Landscape Material Suppliers	106,586 ¹
Total Annual Cubic Yard	182,949

Notes: ¹Does not include compost marketed in bags by this market segment.

5.1.4 - Competing Products

As described in earlier sections, several large suppliers or sources of compost exist in the Austin area. The majority of the compost available is manure or cotton burr based. However,

biosolids and many products which are produced with a combination of feedstocks are also available. Products are available on a wholesale basis for as low as \$7 per cubic yard picked up (Dillo Dirt) and as high as \$29 per cubic yard. Although many compost products are available in the Austin area, the majority are priced high and are considered extremely high quality products. Outside of mushroom soil compost, which may enter the market at a cost comparable to Dillo Dirt, there is little competition for composts which are more economically priced. Although many firms support the Dillo Dirt program, several current customers complained that product quality has varied, paper work can be problematic, and no assistance is provided for trucking of the material. For these reasons, if the LCRA produces a consistently high quality compost product and works to provide improved customer service, they should be able to successfully compete with Dillo Dirt, especially if an upfront effort is made in establishing name recognition for their product.

5.1.5 - Conclusions

Many agricultural and urban by-products are being used as feedstocks for the production and sale of compost in the Austin, Texas area. Preliminary research estimates that between 200,000 and 300,000 cubic yards of compost are utilized annually in the greater Austin area in bulk, bagged, or blended condition. The greatest users of compost are landscape material suppliers, garden centers, landscapers, and of course the ultimate end user, homeowners. Compost products possess excellent value on both the wholesale and retail level, with wholesale prices ranging from \$7 to \$33.50 per cubic yard picked up. Retail prices range from approximately \$20 to \$35 per cubic yard picked up. Aside from the large bulk markets which currently exist, compost products are available in bagged and blended form. Because of Austin's warmer southern climate, the LCRA could expect to market its compost year round with peak usage in the spring and the fall. Poor soils and drought conditions make compost an ideal amendment for local soils. However, many landscapers and homeowners are not purchasing compost for incorporation into the soil. Instead, they are using blended topsoils since they are deemed more convenient to use. In landscape maintenance operations, compost, and particularly Dillo Dirt, is popular for use as a turf topdressing.

The robust local market leaves the LCRA with various opportunities for the distribution of their compost product. It is likely that the LCRA would be successful in marketing their product in bulk, bagged, or blended form using in-house staff, or working through outside firms who would provide brokerage services for them. Being the second biosolids compost available in the area, the LCRA should develop a distribution system which meets the needs of the landscape/nursery industry, taking heed of the sometimes negative comments regarding the Dillo Dirt program. Since the LCRA product would likely be compared to Dillo Dirt before either a cotton burr or manure based product, it must possess as good or superior a quality and it must be consistent in nature. Also, resources must be expended to develop name recognition for the product since the Dillo Dirt name is well established.

5.2 - BULKING AGENT SOURCES FOR COMPOSTING

Preliminary investigation was completed in order to identify potential sources of bulking agent for composting. Bulking agent is used to improve the porosity and physical structure of the compost mix to allow aeration throughout the piles. The bulking agent will also act as a source of carbon, which is necessary for a proper ratio with nitrogen for composting. The LCRA biosolids will provide the nitrogen to the process. Typical bulking agents used in biosolids composting are wood chips, bark, sawdust, ground demolition/pallet wood, and ground yard trimmings.

The goal of this preliminary investigation was to identify potential sources, volumes available, and costs for locally produced bulking agents. This is imperative since a significant cost of operating a composting facility can be attributed to the purchase of bulking agents.

5.2.1 Bulking Agent Requirements

The quantity of bulking agent required to compost a particular biosolids product is based primarily on the quantity of biosolids to be processed. The volume of bulking agent needed is primarily influenced by the volume of biosolids and the moisture content of the biosolids. It is also influenced by the moisture content of the bulking agent. It also depends upon the type of bulking agent (e.g. wood chips, sawdust, ground pallets), its texture/particle size, and purity.

The quantity required on an annual basis will also depend on if screening of the final product is practiced. The more bulking agent that is screened out of the product and recovered for re-use, the less new bulking agent is necessary. Usually, the biosolids are blended with both new (virgin) and recovered (recycled) bulking agent. Reusing the bulking agent is of economic benefit, since it reduces the quantity of new bulking agent required. Based on an initial biosolids production rate of ten dry tons per day (on a five day/week basis) and a 50% bulking agent recovery rate through screening, preliminary calculations estimate that approximately 26,000 cubic yards of bulking agent (yard debris or chipped tree trimmings) will be required annually for a LCRA composting facility.

5.2.2 Local Bulking Agent Availability

Unlike eastern Texas, central Texas does not possess a wood (silviculture) industry. Therefore, sawdust, bark, and wood chips are not available locally at an economic cost. Because of this fact, yard debris, tree trimmings, and ground pallet wood will be a more viable bulking agent to use. In this preliminary research, only yard debris and tree trimmings were investigated because they are more likely to be obtained at no cost to the LCRA. Potential sources identified can be found in Table 5-5.

TABLE 5-5
POTENTIAL BULKING AGENT SOURCES¹

Company/Utility	Type	Bulking Agent	Volume Generated or Collected/Year	Other
City of Austin (Phil Tamez)	City Dept.	yard debris/ brush, chipped line clearing wood ²	20-30,000 yd ³ 50,000 yd ³	use all of material they generate at their Hornsby Bend composting facility - none is available
Asplundh Tree Service (Dan Stahl)	Arborist	chipped tree wood from tree pruning and line clearing	1-2,000 yd ³	source is obtainable, probably generate more than stated volume
Del Webb Sun City Georgetown (Larry Michaels)	Developer	chipped tree wood	unknown	have an estimated 10,000 cubic yards stockpiled currently, chipping trees after land clearing for development of 15 year long project.
City of Georgetown (Hartley Sappington)	City Dept.	yard debris/brush	4-6,000 yd ³	source is obtainable, could double volume by selectively picking up brush during monthly collection of bulking wastes. Believes obtaining source separated yard debris is possible but must negotiate with haulers and change city ordinances
LCRA (Jesse Warren)	Public Utility	chipped line clearing wood ²	Unknown	very little generated, chipped material left at site, brought to dump or to Hornsby Bend composting facility
City of Round Rock (Larry Matson)	City Dept.	yard debris	10-12,000 yd ³	grind material from drop off areas twice a year, give-away most of it and use some once ground. Are interested in having someone take it before in unground.

**TABLE 5-5
POTENTIAL BULKING AGENT SOURCES
Continued**

Company/Utility	Type	Bulking Agent	Volume Generated or Collected/Year	Other
Texas Utilities (Jeff Tweed)	Public Utility	chipped line clearing wood ²	4-8,000 yd ³	currently chip and give-away, interested in a no cost disposal option, supplying convenient dump/pick-up location is critical to obtaining supply
Waste Mgmt. Inc. (Sonny San Filippi)	Private Corp.	yard debris	50-60,000 yd ³	operates Austin Community Landfill (ACL) and Williamson County Landfill (WCL), ACL obtains 50-60,000 of yard debris/yr., but it is mixed with garbage, would like to explore ways to provide LCRA with clean bulking agent. WCL obtains minimal yard debris

Notes: ¹BFI Landfill and Texas Disposal Services Landfills obtain yard debris, but availability to LCRA is unknown at this point
²Chipped line clearing wood - removal of tree limbs from around high voltage electrical lines, on-going maintenance practice
³Information obtained from Hartley Sappington, City of Georgetown - unable to speak with Larry Michaels directly

In order to identify potential sources of yard debris and tree trimmings, several local landfills, cities, and electric utilities were contacted. Currently, the only local city which collects source separated yard debris on an on-going basis is Austin. The city of Austin's Hornsby Bend biosolids composting facility uses all of the city generated yard debris, estimated at 20-30,000 cubic yards per year. It also uses approximately 50,000 cubic yards of wood chips, which they obtain from their local electric utility. Tree branches are removed from high voltage line areas during on-going line clearing practices. Although Austin's yard debris is not available, yard debris from the cities of Round Rock and Georgetown may be. Between 14,000 and 18,000 cubic yards is generated annually at community drop off sites in these two cities. Representatives from the city of Georgetown felt the volume of collected yard debris could double if a guaranteed user is identified. Both communities felt that the ability to stockpile the material at a convenient

location for them would be imperative to consummating an agreement in this area. Therefore the LCRA would likely be responsible for transporting the yard debris to their composting site. Neither city is currently paying to have their chips removed, but they often deliver chips locally. That is why a convenient stockpile location would be an economic incentive for the cities.

Several landfills in the area obtain yard debris, but the majority of it is commingled with garbage. However, source separated yard debris and tree trimmings are sometime received at local landfills from commercial landscapers and tree companies. Most landfills charge tipping fees to receive yard debris which is periodically chipped and stockpiled for use as daily cover or resold to the public. The Austin Community Landfill, operated by Waste Management, Inc. (WMI), receives 50-60,000 cubic yards of yard debris annually, but it is contaminated with garbage to some extent. Their manager, however, is interested in discussing the possibility of reducing the tip fee to obtain clean yard debris, as long as they have someone who will pick it up at the landfill and remove it. The Williamson County Landfill, also operated by WMI, does not receive much yard debris due to its rural location and because burning of yard debris is allowed. However, large volumes of wood chips are received at this landfill from time to time. Currently, 15,000 cubic yards of wood chips are stockpiled at the Williamson County Facility.

Companies which maintain high voltage power lines generate large volumes of tree trimmings which they chip. Similar to local cities, they do not typically pay to dispose of these chips. They attempt to locate individuals near the point of generation who take the chips free of charge. However, this is not always convenient. For this reason Texas Utilities and Asplundh Tree Service are interested in finding an on-going disposal option which is more convenient. Both are willing to supply the LCRA with wood chips if convenient stockpiling locations are identified. The LCRA would be required to pick-up these wood chips if the composting site was not conveniently located.

Large potential sources of free bulking agent, yard debris, and chipped tree trimmings are available locally if the LCRA is willing to manage transportation of the materials. Several sources of uncontaminated yard debris are available from local cities and companies maintaining high voltage lines. Uncontaminated sources of wood chips also appear to be available from a

large community development company (Del Webb). Local landfills may also be able to supply large quantities of yard debris if methods can be developed to reduce or eliminate contamination.

5.3 - POTENTIAL LAND RESOURCES FOR LAND APPLICATION/COMPOSTING

To locate and identify areas suitable for the land application scenarios, E&A developed several criteria to define the boundaries of an initial "study area". These criteria required that the area be:

- Located east of Interstate Highway (IH) 35
- Located no further than 40-50 miles from each of the participating communities
- Within 5 miles of a U.S. or State highway
- Located in an agricultural area currently being farmed, or have soils capable of growing crops
- Located in an area not currently experiencing (and not likely to experience in the near future) urban/suburban development

From these criteria, EH&A selected a study area east of Georgetown and Round Rock, in southern Williamson County, and a study area east of Pflugerville in northern Travis County. In central Texas IH-35 roughly divides the two major physiographic/ecological zones of the region: the Edwards Plateau and the Blackland Prairie. The Edwards Plateau is characterized by hill and canyon topography, thin soils, and limestone bedrock (often exposed at the surface). Agricultural uses of the "hill country" are primarily restricted to ranching. The Blackland Prairie, on the other hand, consists of a broad belt of relatively deep, fertile, clay-rich soils that support a strong farming economy. Locating the study area east of IH-35 also largely avoids potential environmental constraints associated with endangered species and the Edwards Aquifer Recharge Zone, which are primarily confined to the area west of the Interstate.

The northern study area selected by EH&A is adjacent to two of the largest participating communities, Georgetown and Round Rock, and is within 40 miles of the rest of the participants. The area is bounded by State Highway (SH) 29 on the north, U.S. Highway 79 on the south, IH-35 on the west, and SH 96 on the east (see Figure entitled Study Area 1). The southern study area (Figure entitled Study Area 2) is also near the participants, although not as close to the largest sludge generators. This area is bounded by the Travis County limits on the north and on the east;

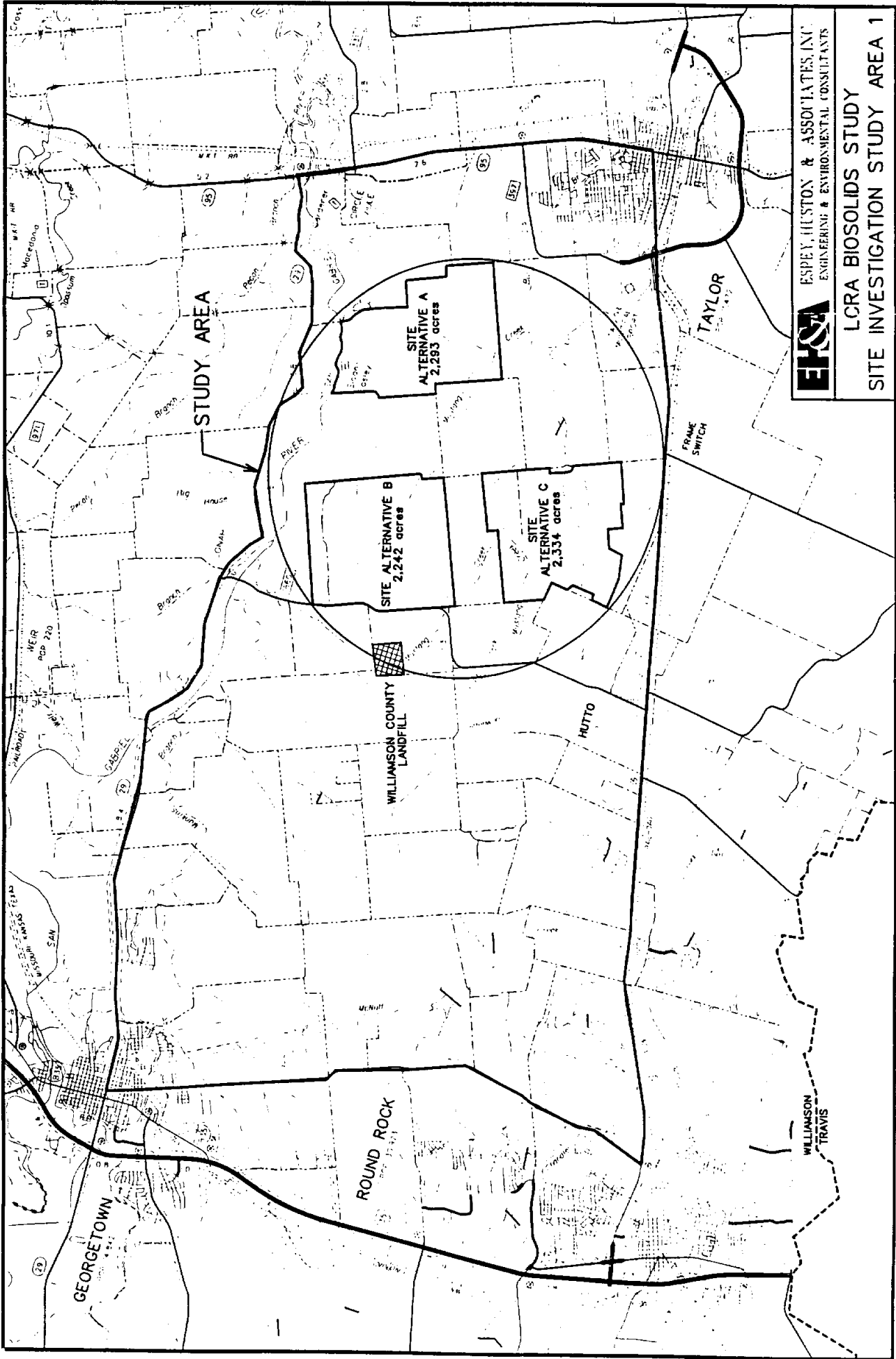

EHS&A ESPEY, HUSTON & ASSOCIATES, INC.
ENGINEERING & ENVIRONMENTAL CONSULTANTS

LCRA BIOSOLIDS STUDY
SITE INVESTIGATION STUDY AREA 1

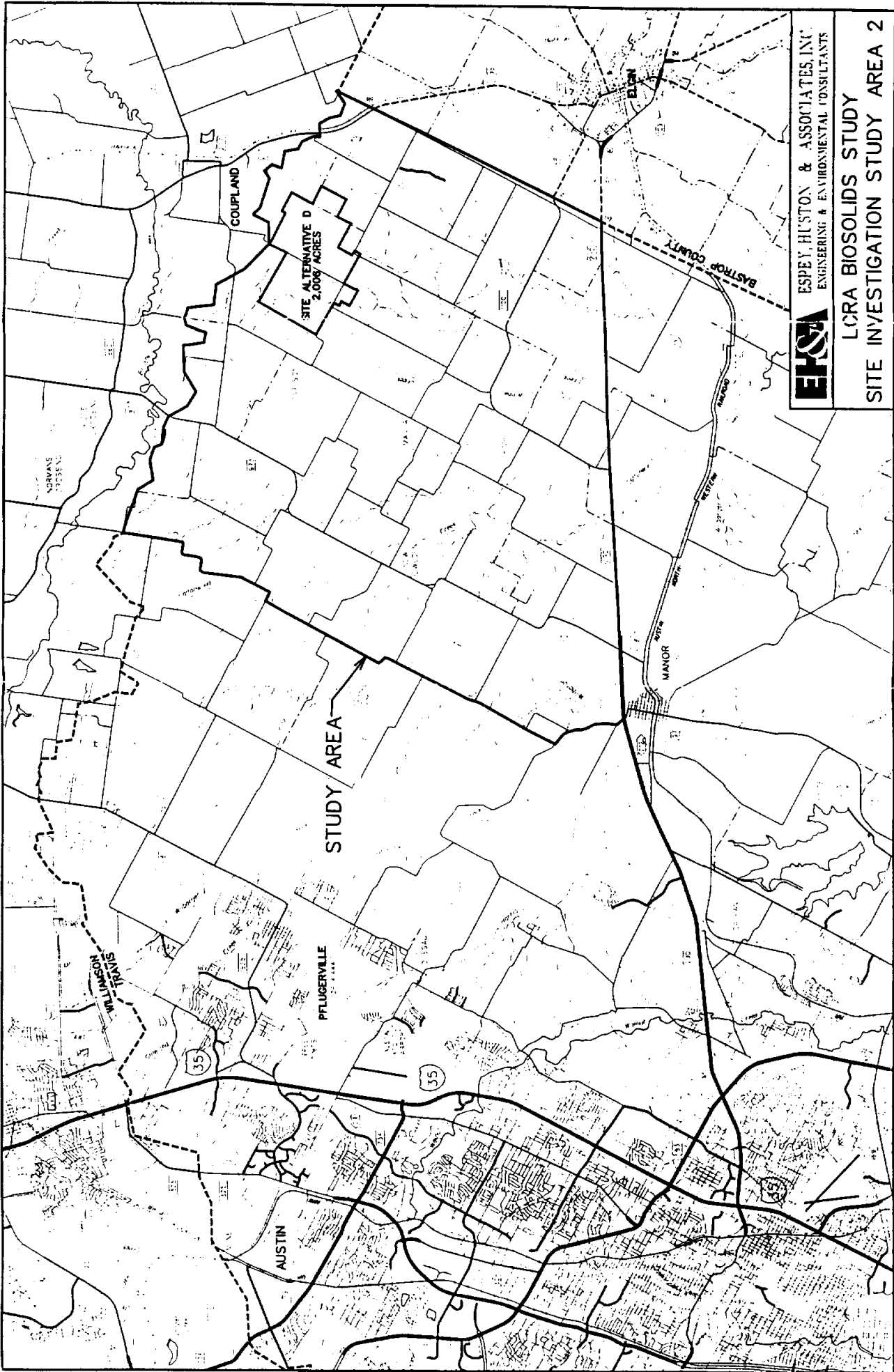

EKSA ESPEY, HUSTON & ASSOCIATES, INC.
ENGINEERING & ENVIRONMENTAL CONSULTANTS

LCRA BIOSOLIDS STUDY
SITE INVESTIGATION STUDY AREA 2

U.S. Highway 290 on the south; and Fuchs Grove Road, Cameron Road, and Engerman Lane on the west.

5.3.1 - Land Requirements

Land area requirements were determined for six different biosolids composting/land application scenarios. These scenarios include land application only for current biosolids production rates and for the year 2005 biosolids production rates. Composting only is an alternative studied for both current and the year 2005 biosolids production rates. Also, two combinations of land application and composting were investigated. The resulting minimum acreage required for each of the six scenarios ranged from 14 to 1,140 acres.

Buffer zones from roadways, environmental features, and inhabited areas will be required on all sides of the selected land application/composting areas. Because the specific site has not been determined, a large area will be designated as buffer in the planning stage. Therefore, for each scenario, the required acreage was increased by 100% for potential buffering purposes. Therefore, the land area requirement for each composting/land application scenario ranges from 28 to 2,280 acres. The investigation for facility location alternatives surveyed sites meeting the larger acreage requirement, in which smaller acreage could be selected if warranted.

5.3.2 - Land Related Issues

The southern Williamson County and northern Travis County areas east of Interstate 35 are largely under agricultural use. The majority of the population live in suburbs that are clustered around the major cities along Interstate 35 and intersecting U.S. highways. Williamson County was settled in the early 19th century, and it was organized into a county in 1848. Many of the original farming family descendants still live and farm the land.

According to Williamson County Agricultural Extension Agent Lee Garrett, between 50,000 and 60,000 acres of the county are planted in cotton, approximately 45,000 acres are planted in corn, 50,000 acres are planted in sorghum, and 30,000 acres are planted in oats and wheat. He also indicated that Williamson County is a traditional Texas county with families

farming the same piece of land for over 150 years, yet they are very open minded to new and cost effective farming techniques and operations.

Both the northern and southern study areas consist of level to rolling Blackland prairie. Southeastern Williamson County is drained by the San Gabriel River and its tributaries while northeastern Travis County is drained by Willow Creek discharging to the Colorado River. An average rainfall of 34.2 inches, a growing season of 258 days, and the fertile quality of the soil combine to make agribusiness the primary economy in these portions of the county. Cash crops such as sorghum, corn, cotton, and wheat are grown throughout the study areas and account for approximately 90% of the land use.

5.3.3 - Available Land

Two areas were selected in southeastern Williamson County and northeastern Travis County that met all of the established land application criteria. A first-hand knowledge of the area greatly facilitated the site alternative selection, and aided in the collection of information about the area. The study area's proximity to Austin allowed for a brief field check of the site alternatives. Telephone conversations with realtors in the area indicated that prime agricultural land sells for \$1,000 to \$2,000 an acre in eastern Travis and Williamson Counties.

Using land ownership and tax plat maps from the Williamson and Travis County Appraisal Districts, an area relatively free of development (i.e.: subdivisions, schools, and churches, etc.) was selected in the eastern portion of the study area for placement of the site alternatives. The areas selected are sparsely populated, and the majority of the population live in isolated farm houses. The study area is planted in corn, sorghum, cotton and, to a minor degree, hay. Numerous small county roads bisect the area, and a few intermittent drainages cross the study area.

The land in both the southeastern portion of Williamson County and the northeastern portion of Travis County is divided into relatively small tracts of 100 acres or less. However, there are a few large tracts in excess of 400 acres within the study areas. An attempt was made to locate the alternatives on the largest tracts of land possible, and away from the more populated

areas. To be able to locate approximately 2,000 acres, many separate small tracts were combined into the site alternatives.

Site A is the northeastern-most alternative, and it is the second farthest alternative from the participating municipalities. The terrain of Site A is more rolling and more rugged than the other alternatives, as well as having more homes and being more populated. Site A is 2,293 acres and it has 19 land owners. This site is adjacent to and northwest of the City of Taylor (population 11,472). Site A borders the San Gabriel River on the north, and the land generally slopes down to the north toward the river. An established gravel quarry is located at the northeast end of Alternative A, and a cemetery is located on a north facing slope overlooking the San Gabriel River. The land is primarily planted in corn with a few fields being planted in cotton.

Site B is the most level of the alternatives, and it has fewer houses than the other three alternatives. Site B is 2,242 acres and it has 14 land owners. It is primarily planted in cotton with a few fields being planted in corn, sorghum, and hay. Paved county roads almost totally surround this alternative, and an improved Farm-to-Market road (FM 1660) borders the site along the west. The Williamson County Landfill is adjacent to and west of this alternative.

Site C has more homes and a denser population than the other alternatives. It is 2,334 acres and it has 22 land owners. Site C is located near the community of Hutto (population 630). Two sections of an intermittent stream, Mustang Creek, dissect this alternative, and a catfish farm is adjacent to and down stream of this site. An improved county road cuts part way through this alternative near the northern edge and leads to a couple of homes in the middle of Site C. This alternative has more land planted in hay than the other alternatives, and there is about an equal mix of corn and cotton planted within this alternative.

Site D is located near Coupland, northeast of Manor. It is 2,006 acres and has fourteen land owners. Nearly all of the land is planted in a variety of crops, and there are a minimal number of houses in this area. Both Little Willow and Willow Creeks run through the site, although the land remains relatively level over the entire area. This alternative is fairly accessible, since State Highway 95 runs very near to the site and all the roads in the region are paved.

Site Alternatives A through C are located within 40 miles of the participating municipalities, and all are less than 5 miles from a U.S. or State Highway. The land is prime agricultural farmland supporting cash crops. The alternatives are located outside of areas of potential urban/suburban development. However, Alternatives A and C are in close proximity to small communities which could potentially develop in the directions of the site alternatives, yet property ownership suggests that suburban development will occur south and west of U.S. Highway 79 near Taylor and west of the community of Hutto near Round Rock.

Site Alternative B is considered to be the preferred alternative because of its ease of access, the level terrain, the sparse population, and its proximity to the Williamson County Landfill. Site Alternative A is considered as the second choice because of its sparse population, yet it has an established industry, the gravel quarry, in the northeastern section, and it also slopes down to the north and drains into the San Gabriel River. Site Alternative D is farther away from the participants, approximately 8 miles southeast of the alternatives A, B and C. Site Alternative C would be considered less desirable than site alternative A or B because of the denser population and its proximity to the community of Hutto. Site Alternative D is in the proximity of the community of Coupland.

6.0 - PRELIMINARY DESIGN

This chapter provides a description of the rationale used in selecting land application and composting alternatives for detailed cost analysis in Chapter 7.

6.1 - ALTERNATIVES SECTION

Selection of alternatives for further evaluation is based on numerous factors including, but not limited to:

- Biosolids quantity
- Biosolids metal quality
- Biosolids solids content
- Technology suitability
- Technology track record
- Owner preference

Table 2-1 summarizes the estimated quantity of biosolids generated at each of the 12 facilities in 1995. Two of the main issues influencing how much biosolids will be available for a joint program include which communities will participate and when the program will be implemented. Overall biosolids generation is expected to double by the year 2005. Due to the fact that several entities could be involved, it is likely that at least one to three years will pass prior to any program implementation. This time period will likely result in biosolids quantities 20% to 30% more than shown in Table 2-1.

Table 2-3 summarizes the results of a one-time biosolids sampling in June 1996 for metal concentration as well as several other parameters. Biosolids from all facilities meet metal concentration limits of the U.S. EPA 503 requirements for Class A. Based on this factor, all materials could be considered for land application or composting.

Biosolids total solids content is another factor which must be considered. Land application of both liquid and cake can be performed. However, an initial investigation into land application of those entities which generate only liquid biosolids found their costs to be significantly higher than other options due to the large amount of water which would be transported. Composting should only be practiced with dewatered biosolids in order for economics to be acceptable. Since many of the plants dewater their biosolids either mechanically (belt filter press) or physically (sand drying beds), biosolids cake from these operations is suitable

for composting. Biosolids from Anderson Mill MUD, Lost Creek MUD, and half of Brushy Creek MUD's production are only thickened and, therefore, require further dewatering. At a review meeting for the project, it was agreed by all parties that dewatering of liquid biosolids from these three plants should be practiced. Dewatering could be performed periodically on-site using mobile equipment, or liquid biosolids could be transported to another wastewater plant for dewatering.

Technology suitability should be matched to the characteristics of the biosolids and also take into account previous performance (track record), cost, and owner preference. For land application, only application of cake appears economically feasible. For composting, site specific characteristics can play a big role in selecting the technology. Windrow or aerated windrow take the most land, are the most prone to weather impacts, and also have the greatest odor potential. Aerated static pile can be accomplished uncovered, covered, or totally enclosed depending on the level of odor control required. Agitated bed is typically best suited for larger quantities, has a high degree of process control, but has the highest cost. Based on these factors, and the fact that a site has not been chosen for consideration, a mid-range composting technology is appropriate for consideration. Therefore, covered aerated static pile with partial odor control of the process offgas will be considered in the design basis. Land application of the entire biosolids quantity in a cake form will be considered. In order to develop a range of costs for composting for which costs are more size dependent, a base case quantity of 1,950 dry tons per year or 7.5 dry tons per operating day (5 day/week basis) and a future capacity of 3,900 dry tons annually or 15 dry tons per day will be considered. These quantities equate to roughly 75% of the existing cake quantity in the base case and 150% in the future case.

The alternatives, then, which will be evaluated are as follows:

Alternative 1

Land apply 2,830 dry tons per year as cake

Alternative 2

Compost 1,950 dry tons per year as cake (base case)

Compost 3,900 dry tons per year as cake (future case)

6.2 - LAND APPLICATION DESIGN CRITERIA

6.2.1 - Biosolids Processing Capacity

The following section contains estimates for acreage needed to apply biosolids generated by the participating entities. The estimates assume that the biosolids contain an average of 5.6% organic nitrogen and 0.3% inorganic nitrogen. The calculations also assume that the metals levels of the biosolids will not limit the application and that pathogen reduction and vector attraction reduction requirements have been achieved.

Land application acreage needs have been calculated for one scenario. The total dry tons generated from all of the communities represent the quantity to be applied. Several communities have biosolids with low percent solids content. Biosolids from all participating entities are assumed to be managed at plants with dewatering capabilities or dewatered on-site. Therefore, this analysis assumes all dry solids will be dewatered and land applied. Table 6-1 below shows the dry tons generated per year.

TABLE 6-1
ANNUAL DRY TONS GENERATED

SCENARIO	ANNUAL DRY TON PRODUCTION
All Communities	2,830

As shown in Section 4, the calculation of agronomic loading rate at 200 lb/acre is approximately seven dry tons per acre (for first year of application at site) for these biosolids. Estimates for acreage needed to apply all the materials for the two alternatives is shown below. If land application is chosen as a reuse method, additional information will be gathered concerning application site background information, application method, crop rotations, fertilizing practices, and more. For the purposes of this estimate, it is assumed that twice the required area will be needed to account for buffers and crop rotation. This estimate assumes that

immediate incorporation into the soil will be practiced which means no losses to the atmosphere through volatilization. Losses to the atmosphere would translate to a higher application rate. In addition, a mineralization rate of 20% has been assumed for the calculation of available organic nitrogen. Table 6-2 below shows the acreage needed for application to a variety of crops.

TABLE 6-2¹
ACREAGE NEEDED FOR APPLICATION OF BIOSOLIDS W/28.4 LB. AVAILABLE NITROGEN/DRY TON

Crop	Lb/Acre Nitrogen Needed	Dry tons/Acre	Estimated Acres Needed	
			2,830 dt/yr	5 yr. total
Cottonseed	62	2.2	1,297	1,843
Grain sorghum	80	2.8	1,005	1,467
Wheat	125	4.4	643	939
Oats	150	5.3	536	782
Corn	200	7.0	402	587
Orchard grass	300	10.5	268	391
Alfalfa hay	330	11.6	244	356

¹No buffers included

These estimates do not include any residual nitrogen in the soil at the chosen site, which can reduce slightly the application rate. In addition, the estimate above is for the first year of application at a site and the fifth year of application. Organic nitrogen is released slowly over the course of approximately five years when concurrent applications occur for several years on the same site. This release will need to be accounted for in subsequent calculations for application to a site. After five years, the biosolids nitrogen is considered part of stable soil organic matter and is included in calculations of background levels of nitrogen. Table 6-3 shows the residual organic nitrogen available in the soil for five years after application and the acres required for application of the biosolids each year.

TABLE 6-3
RESIDUAL NITROGEN DUE TO PREVIOUS APPLICATION

% Inorganic Nitrogen	% Organic Nitrogen	Mineralization rate	Lb. Nitrogen/dt as Applied 1	Subsequent Years Available Nitrogen Lb N/Dry Ton for Years				
				2	3	4	5	
0.3%	5.6%	20%	28.4	8.8	3.3	1.1	1.1	
Acres needed to apply 200 lb nitrogen/acre								
			Alternative 1	402	497	545	569	587
			1A ¹	804	994	1,090	1,138	1,174

¹ Accounts for buffer and crop rotation needs

6.2.2 - General Design Criteria

This section of the report defines several facility design criteria which are used in subsequent cost analyses for the two land application alternatives evaluated.

6.2.2.1 - Material Transport

Materials will need to be transported to the land application site via transport truck. Dewatered materials can be transported with an end dump tractor trailer, off-loaded at the site, and transferred to the manure spreader with a front end loader. In general, these end dump type trucks are required to have a tarp on top to help prevent unwanted discharge during transport.

6.2.2.2 - Material Storage

The storage of materials at a site is allowed for up to 90 days. As seen in Table 6-4, the cropping schedule in the area typically has a maximum of a three month period where both summer and winter crops are on the fields. During this period, the biosolids materials must be stored. This storage may be necessary to accommodate inclement weather or crop harvest. The storage area is required to be equipped with a liner and must catch all runoff from the area. The liner must have a permeability of 1×10^{-7} cm/sec or less. For inclusion of all biosolids generated

by the participating entities, an area of approximately one half acre would be sufficient for the storage of 90 days generation rate of dewatered biosolids. Written authorization must be obtained from the executive director of the TNRCC prior to construction of any storage area.

TABLE 6-4
TYPICAL CROP ROTATIONS AND WET MONTH RAINFALL
IN THE TRAVIS AND WILLIAMSON COUNTY AREAS

Crop	Jan	Feb	Mar	Apr	May	Jun	Jul	Aug	Sep	Oct	Nov	Dec
	Inches of rain for wet months											
				2.6	4.8	3.7			3.3	3.4		
Cottonseed - s			p	h	h	h	h	h				
Grain sorghum - s			p	h	h	h	h	h				
Wheat - w	p	h	h	h	h				p	h	h	h
Oats - w	p	h	h	h	h				p	h	h	h
Corn - s			p	h	h	h	h	h				
Coast berm. grass -s			p	h	h	h	h	h				

p - plant
h - harvest
s - summer crop
w - winter crop

55,000 acres cultivated in the County
80% summer crops
20% winter crops

32 inches of rainfall annually

Open blocks are time periods available for land application of biosolids

6.2.2.3 - Operating Schedules

Schedules for operating the application site will be eight hours per day, five days per week, 52 weeks per year, weather permitting. It is assumed that the operation of the site will be conducted by LCRA personnel. If this is not desirable, the site can be operated by a contractor. Many such contractors operate throughout the Country, and a request for proposals process will yield many responses.

Application of 50 wet tons of biosolids per day on average will require two trips per day to the site. Each trip is assumed to require approximately one hour. The dewatered biosolids which are surface applied will also need to be tilled in under the surface of the soil. This will take an additional hour per day. The total application time including equipment transfer (the same tractor is used to pull both pieces of equipment) is approximately 6 hours. Additional time will be required for record keeping (daily) and sampling/monitoring (intermittent basis).

6.2.2.4 - Site Condition Assumptions

Because no site has been chosen, the following assumptions have been made for the facility. These include:

- Suitable road access is available to the site, up to within 1,000 feet of the application field
- No unusual site conditions are included and it is assumed that there is little surface water on or near the site
- The water table is at a suitable distance from the surface of the soil
- Crops will be grown on the site in order to establish beneficial reuse of the biosolids
- Biosolids will be applied at agronomic loading rates which will match the nitrogen uptake of the crops grown

Biosolids from the participating entities will likely need to be mixed at the site. This can occur at the storage area. The EPA views mixing and blending biosolids at a regional facility as a viable method of beneficial use. This activity can be accomplished with the front end loader at the site. The blended materials must be tested prior to application in order to assure compliance with the appropriate regulatory requirements.

6.2.2.5 - Applying

Application at the site must be accomplished in a manner which ensures that agronomic loading for the chosen crop is not exceeded. This rate is defined for each plot of land depending on the crop to be grown, the previous biosolids application, and the naturally occurring background levels of available nitrogen. Taking each of these factors into account, an application rate will be determined for each plot of land. The application rate will be defined by solids content of the material, most recent nutrient analysis, and speed of discharge of the spreader.

For a rate of seven dry tons per acre at 20% solids, this equates to approximately 39 cubic yards per acre or 0.3 inches across the entire acre. Application in a blanket layer is not possible for dewatered biosolids, so the known cubic yardage of the spreader will need to be applied evenly over a known square foot area. The chosen spreader is a 27 cubic yard model, so a full load will need to be spread evenly over seven tenths of an acre.

6.3 - COMPOSTING DESIGN CRITERIA

This section of the report defines several facility design criteria which are used in subsequent cost analyses for the two composting scenarios evaluated.

6.3.1 - Biosolids Processing Capacity

Table 2-1 shows the annual biosolids production data for the participating entities in the feasibility study. Daily biosolids production on a five day per week basis ranges from a low of less than 0.1 for Manor to 5.6 dry tons per day for the City of Round Rock (both East and West facilities). A total biosolids production rate for all entities involved in the analysis is 7.75 dry tons per day on a five day per week basis. These values are based on 1995 annual production records.

Based on the alternatives selection discussion, the following two biosolids processing capacity systems will be evaluated:

- 7.5 dry tons per day of biosolids on a five day per week basis (1,950 dry tons per year)
- 15 dry tons per day of biosolids on a five day per week basis (3,900 dry tons per year)

Cost analysis of these two sized facilities will provide a range that could be expected for both present and future biosolids quantities.

The single most critical factor in terms of facility size and economics on a dry ton per day capacity is cake solids concentration of the biosolids. As Table 2-3 indicates, cake solids concentration ranges from 14% to 60% for the 10 facilities which dewater by belt filter press or sand drying beds. On a weighted basis, the average solids content is 27% TS. However, due to limited analytical data and the fact that winter time drying bed performance will be poorer, an overall average of 20% TS is being used as a basis for design. This assumption provides a

level of conservancy in the design of the composting facility. However, if results of additional sampling data indicate a dryer cake solids can continue to be achieved, less materials handling and small facilities will be required. This will result in an overall lower unit cost for biosolids composting.

6.3.2 - General Composting Design Criteria

This section of the report addresses ancillary issues outside of the main processing areas within the composting facility.

6.3.2.1 - Materials Transport

The materials which would be transported to a composting facility include dewatered biosolids and clean processed yard wastes. Other potential materials which can be accommodated at the facility are woodchips. Transporting of these materials to the composting facility will be the responsibility of LCRA or the participating entities (i.e., LCRA or the participating entities must provide personnel and equipment to haul biosolids, yard waste, and other waste materials for delivery to the composting facility during normal operating hours). Vehicles which can be accommodated at the facility must be self-tipping, such as dump trucks, live-bottom trailers, or other means for dumping loads onto storage pads.

6.3.2.2 - Materials Delivery, Receiving, and Storage

Materials delivery to the composting facilities will be accommodated on an eight hour per day basis, five days per week on a Monday through Friday schedule. Exact hours of operation can be determined at a later date. However, from the standpoint of conceptually sizing the facilities, an eight hour work day has been assumed. It is assumed that a set of weigh scales will be provided to determine weights of materials received and removed from the composting facility. Biosolids receiving will be in a paved, covered building, adjacent to the mixing system. A series of concrete bunkers will be used for participating entities to deposit their loads of biosolids. Space has been provided in the facilities to allow for storage of up to half a days

composting facilities is attributable to the active high rate composting process itself. For this reason, both composting facilities are based on a covered receiving, mixing, and composting building with compost process exhaust gases being treated through a biofiltration system. Curing, screening, and material storage areas are in combinations of covered or open storage pad areas.

6.3.3 - Aerated Static Pile Composting Facility

Figure 6-1 shows the process flow diagram associated with the aerated static pile technology. A description of the process follows.

6.3.3.1 - Biosolids Receiving

Biosolids from the participating entities will be trucked to the composting facility. Vehicles containing biosolids will be weighed and then directed to the receiving area under roof where loads of biosolids will be dumped into receiving bunkers.

6.3.3.2 - Yard Waste Receiving/Processing

Clean ground yard wastes will be trucked to the regional composting facility by LCRA or the participating entities or other suppliers and weighed at the composting facility. Grinding equipment/facilities are not included. It is assumed that participating entities can supply clean, chipped yard wastes using their own equipment or through a mobile equipment contractor. Further analysis and planning is required in the preliminary design stage to refine this concept. After weighing, vehicles will be directed to an open storage pad where the materials will be inspected and dumped for storage. Approximately 30 days of ground yard waste wood chips storage capacity is provided for at the facility. A covered storage area will be provided to allow storage of a one week supply of new bulking agent. In addition to being covered, this area will have concrete pushwalls and can accommodate any type of bulking agent which needs to be kept dry. The ground yard waste/wood chips storage area is assumed to be an open pad which will allow stacking of ground bulking agent in a 12-foot high pile and stored for a period of 30

FIGURE 6-1 AERATED STATIC PILE PROCESS FLOW DIAGRAM

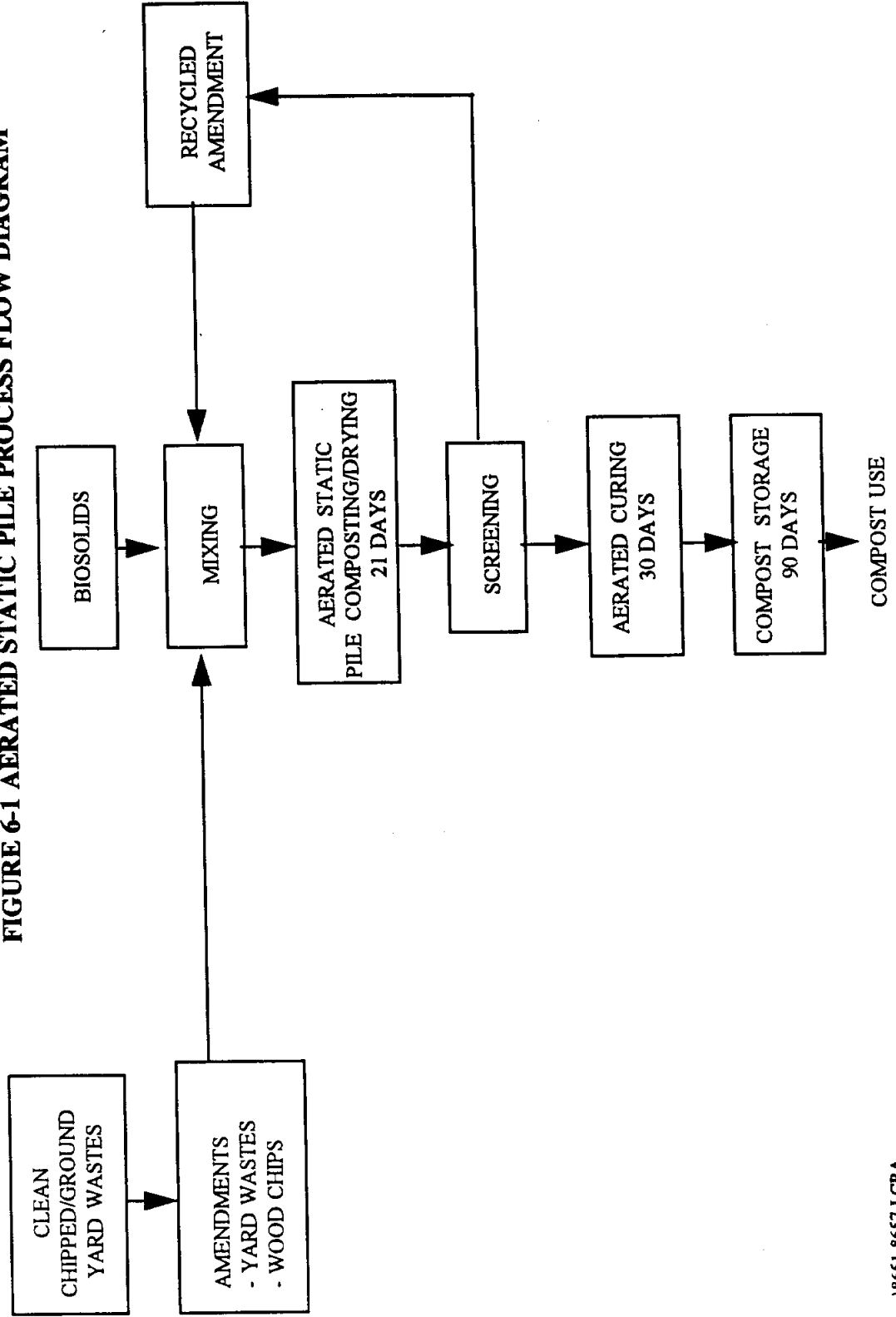

calendar days or 22 operating days. Provision has also been provided for an open storage pad for recycled bulking agent up to 15 calendar days or 11 operating days.

6.3.3.3 - Mixing

Ground yard wastes, recycled amendment, and any other materials to be used as bulking agent will be placed into a batch mixing box for processing. The batch mixer has a capacity of 18 cubic yards and is outfitted with weigh scales such that precise quantities of amendment and biosolids can be measured, and subsequently, mixed. Two batch mixers will be provided for in the 7.5 dry ton per day facility and three in the 15 dry ton per day facility to allow for redundancy. These mix boxes, after being loaded with appropriate quantity of biosolids and bulking agent, will mix the contents in a period of about five to ten minutes and then discharge the contents into a surge pile in a three-sided concrete bunker. Front-end loaders will be used to load the material into the mix boxes, and also to pick up mixed material and place it into the aerated static pile. The batch mixers will be permanently mounted and electrically driven. These facilities will be located under cover .

6.3.3.4 - Composting

The aerated static pile composting and drying process will occur in a covered, open-sided pre-engineered building that has concrete flooring and pre-cast trenches to provide aeration. The area will be sized to provide 21 calendar days worth of composting and drying , and also to allow access for pile construction and teardown activities. The process flow in the aerated static pile area includes the placement of a base of wood chips on which an eight-foot layer of initial mix of biosolids and bulking agent will be placed, and a one-foot cover of finished compost as an insulation layer. The extended pile configuration, as shown in Figures 6-2 and 6-3 will be used in the aerated static pile portion of the process. Multiple blower stations will be provided to allow for maximum control and the capability of running in either a downdraft, negative aeration mode or an updraft, positive aeration mode. Process offgases from the aeration blowers will be collected and treated through an open biofiltration treatment system. The aerated static pile blower system will be controlled by a computer control system that has temperature feedback

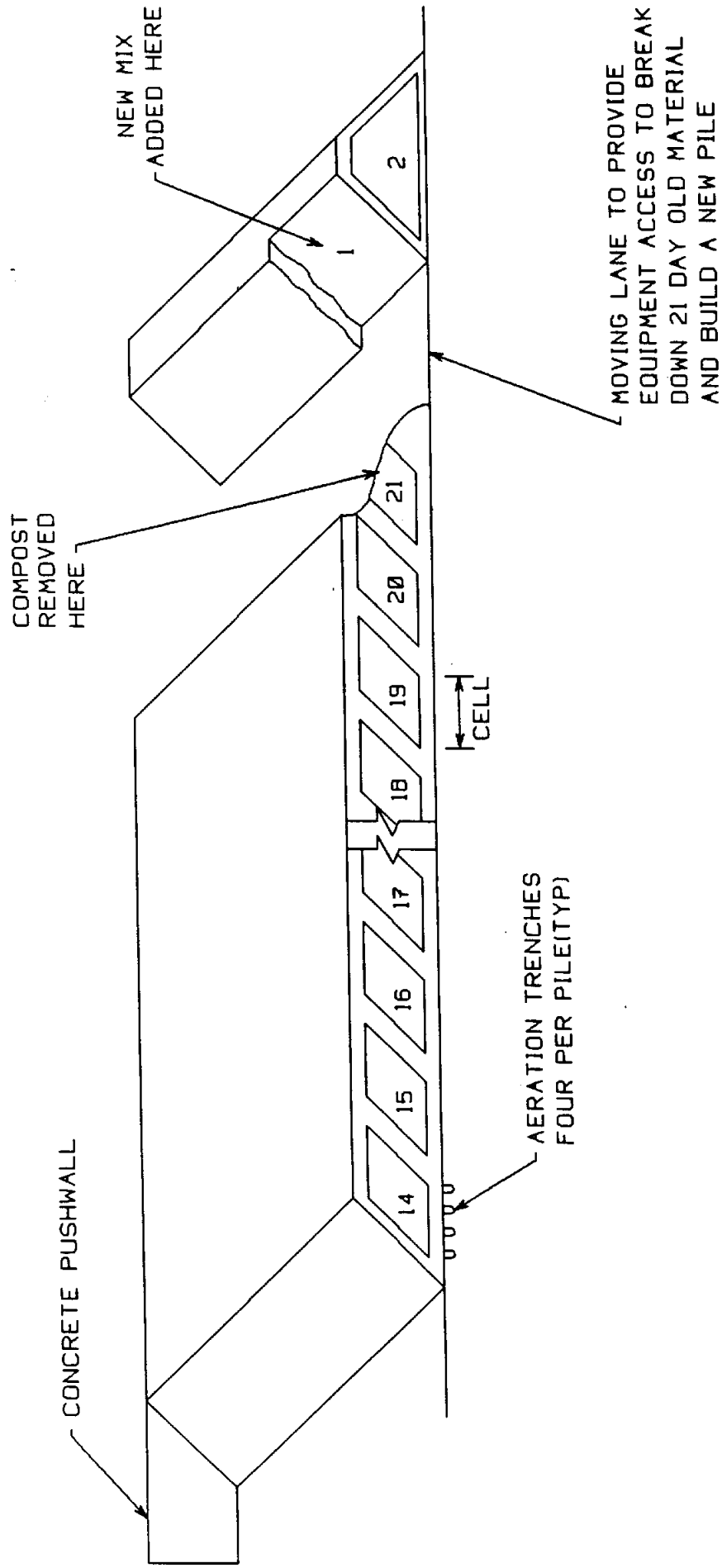

FIGURE 6-2 AERATED STATIC PILE
 TYPICAL EXTENDED PILE CONFIGURATION
 CROSS SECTION

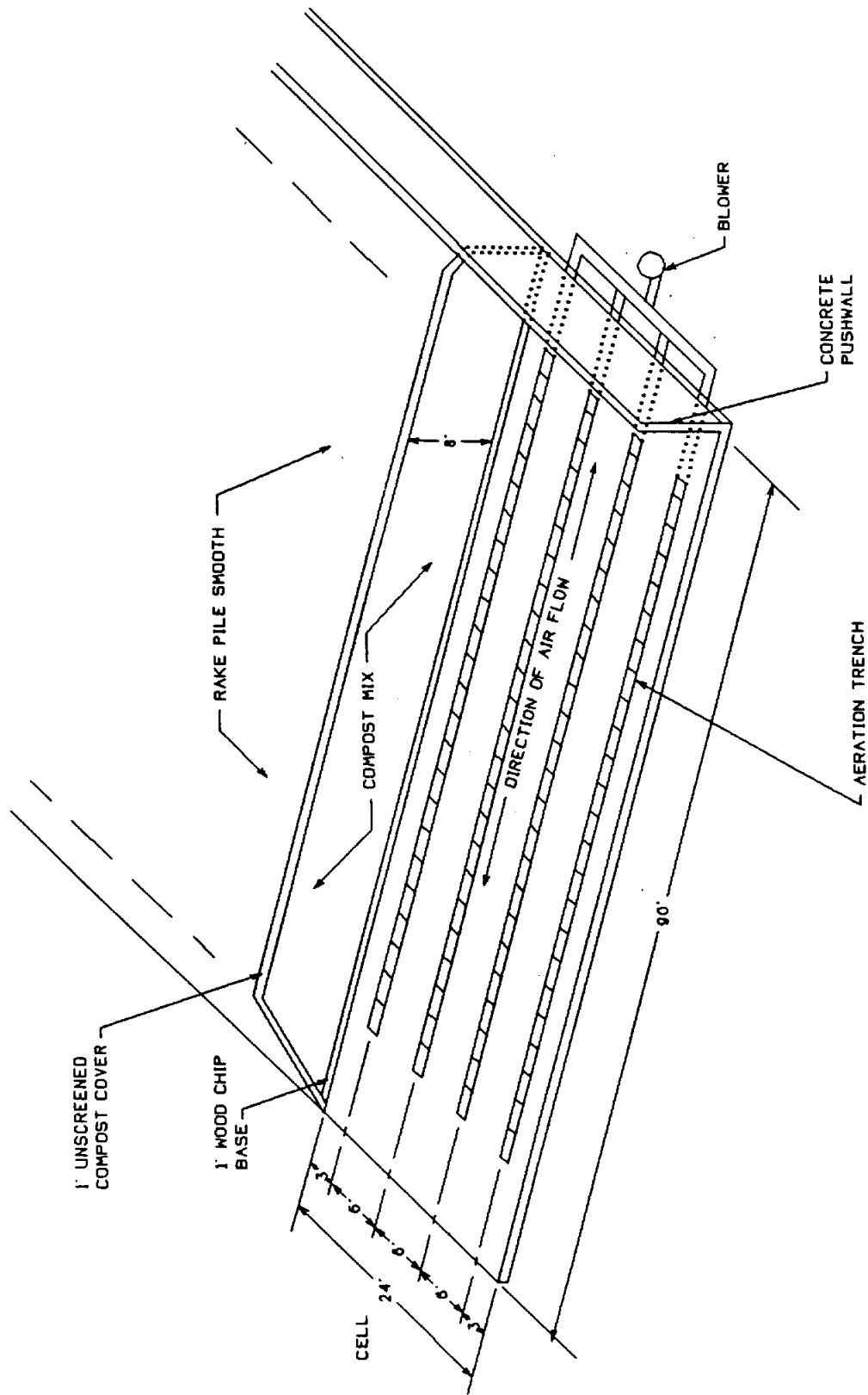

FIGURE 6-3 AERATED STATIC PILE
TYPICAL EXTENDED PILE CONFIGURATION
ISOMETRIC

probes, three per blower. In this way the aeration rates for different compost piles in varying stages of the process can be controlled to achieve optimal temperatures and provide adequate aeration for the drying needs of the process as well.

6.3.3.5 - Screening

At the completion of composting, the material will be picked up by front-end loader and taken to a screening feed hopper which will feed a rotary trommel screen. The screen area will be under cover so it can be operated during inclement weather. The screen size is variable, but will probably be about $\frac{3}{8}$ of an inch in size. Screened compost will then be transported by front-end loader to an extended aerated curing portion of the process. The recovered amendment will be recycled back into the mixing process.

6.3.3.6 - Curing and Storage

Aerated curing is provided for a period of 30 calendar days under cover. Multiple aeration stations controlled by independent cycling timers will be provided to allow flexibility of constructing curing piles in the extended aeration mode. Aerated curing is designed to run in a positive aeration mode only. Reusable high density polyethylene aeration pipe is planned to be used in the curing process, and the curing pad will be constructed of asphalt. After 30 days of curing under cover, the compost will be moved outside onto an open asphalt storage pad until it is sent to market. Ninety days of compost storage has been provided for to allow for storage during the low demand periods of the year such as the winter time and the middle of the summer. The compost will be ready to be marketed after the aerated curing process, but the additional storage is necessary to allow for operation or backlog of the material when product demand is low.

6.3.3.7 - Materials Balances

Materials balances for the two different capacity aerated static pile facilities are shown in Tables 6-5 and 6-6. These materials balances are developed based on assumed biosolids and ground yard waste characteristics. The primary contributing factor to the establishment of the

**TABLE 6-5
MATERIALS BALANCE FOR LCRA
7.5 Dry Tons Per Day Aerated Static Pile
5 Day per Week Design Basis**

Item	Volume (CY)	Total Weight (lbs)	Dry Weight (lbs)	Volatile Solids (lbs)	Bulk Density (lbs/CY)	Solids Content (%)	Volatile Solids (%)
Biosolids	47	75,000	15,000	9,000	1,600	20	60
New Wood Chips	79	39,375	23,625	23,153	500	60	98
Recycle	79	47,250	25,988	24,688	600	55	95
Mix	184	161,625	64,613	56,841	879	40.0	88
Loss		59,650	8,526	8,526			
Unscreened	146	101,975	56,086	48,315	700	55	86
Base (Recycle)	28	16,554	9,105	8,650	600	55	95
Cover (Compost)	29	20,601	11,331	9,760	700	55	86
Screen Feed	173	118,530	65,191	56,964	684	55	86
Recycle	106	63,804	35,092	33,338	600	55	95
Compost	61	54,725	30,099	23,626	900	55	78
BULKING AGENT TO BIOSOLIDS RATIO				=	3.36 (Volumetric)		
				=	1.16 (Gravimetric)		

Assumptions:

1. Bulk densities, total solids and volatile solids content of biosolids, woodchips, recycle and compost are assumed values.
2. Mix solids content of at least 40%TS and a minimum BA/SL ratio of 2.0:1 is required.
3. Mix volatile solids loss of 15%.
4. Screen recycle woodchips recovery of 50%.
5. Pile mix height of 8' with a base and cover depth of 1'each (valid for pile lengths of between 60 and 100 feet)
6. New wood chips are shredded yard wastes

8/21/96 by TOW

**TABLE 6-6
MATERIALS BALANCE FOR LCRA
15 Dry Tons Per Day Aerated Static Pile
5 Day per Week Design Basis**

Item	Volume (CY)	Total Weight (lbs)	Dry Weight (lbs)	Volatile Solids (lbs)	Bulk Density (lbs/CY)	Solids Content (%)	Volatile Solids (%)
Biosolids	94	150,000	30,000	18,000	1,600	20	60
New Wood Chips	158	78,750	47,250	46,305	500	60	98
Recycle	158	94,500	51,975	49,376	600	55	95
Mix	368	323,250	129,225	113,681	879	40.0	88
Loss		119,299	17,052	17,052			
Unscreened	291	203,951	112,173	96,629	700	55	86
Base (Recycle)	55	33,109	18,210	17,299	600	55	95
Cover (Compost)	59	41,202	22,661	19,521	700	55	86
Screen Feed	347	237,059	130,383	113,928	684	55	86
Recycle	213	127,609	70,185	66,676	600	55	95
Compost	122	109,451	60,198	47,253	900	55	78
BULKING AGENT TO BIOSOLIDS RATIO				=	3.36 (Volumetric)		
				=	1.16 (Gravimetric)		

Assumptions:

1. Bulk densities, total solids and volatile solids content of biosolids, woodchips, recycle and compost are assumed values.
2. Mix solids content of at least 40%TS and a minimum BA/SL ratio of 2.0:1 is required.
3. Mix volatile solids loss of 15%.
4. Screen recycle woodchips recovery of 50%.
5. Pile mix height of 8' with a base and cover depth of 1'each (valid for pile lengths of between 60 and 100 feet)
6. New wood chips are shredded yard wastes

8/21/96 by TOW

proper materials balance is to provide enough bulking agent to meet the requirements of the composting process. In the aerated static pile technology, a minimum mix solids content of 40% is assumed. Therefore, the quantity of new and recycled bulking agent must be sufficient in order to achieve this 40% solids. A 20% total solids cake biosolids has been assumed on average. However, a range of solids contents can be accommodated at the facility resulting in either an increase or decrease in bulking agent quantity. Figures 6-4 and 6-5 show the relationship of bulking agent quantity compared to cake solids content on a volumetric and gravimetric basis, respectively. Other assumptions for the aerated static pile materials balances include a volatile solids loss of the mixture of 15% and a recycled bulking agent rate of 50% of the input bulking agent (new wood chips) on a volumetric basis.

FIGURE 6-4 BULKING AGENT TO BIOSOLIDS RATIO AS A FUNCTION OF SOLIDS CONCENTRATION

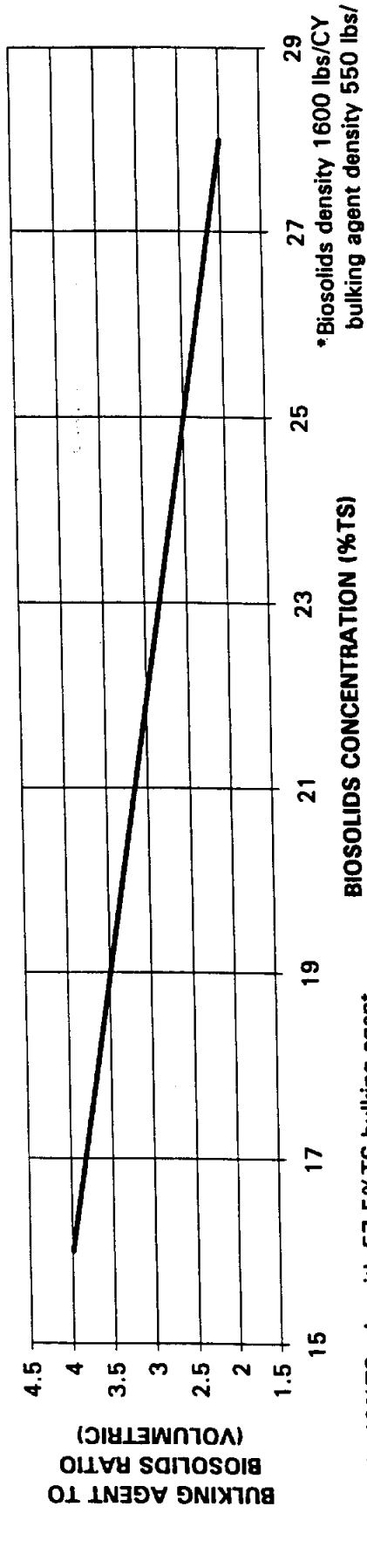
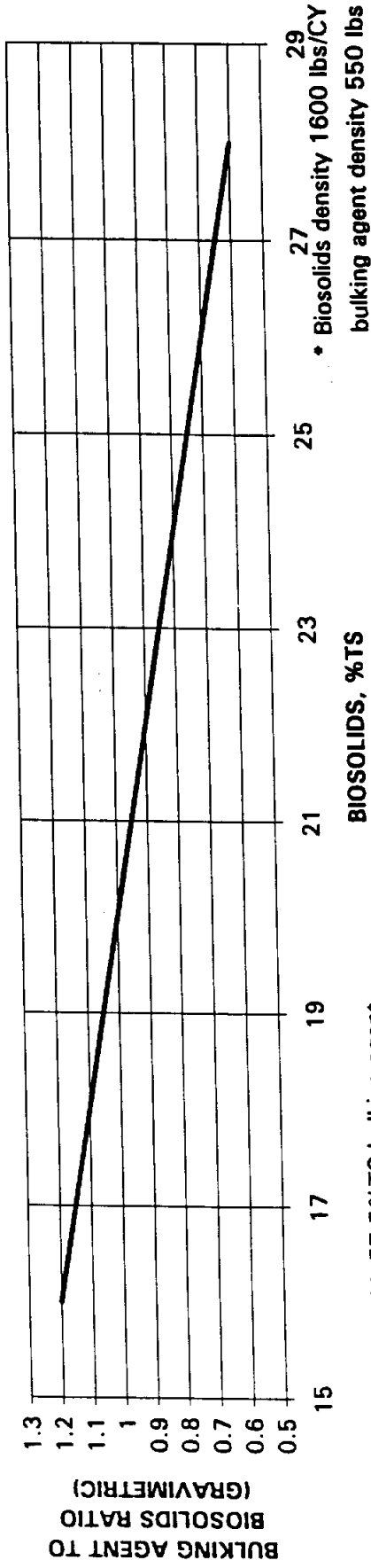

FIGURE 6-5 BULKING AGENT TO BIOSOLIDS RATIO AS A FUNCTION OF SOLIDS CONCENTRATION



• To obtain 40%TS mix with 57.5%TS bulking agent

7.0 - COST ANALYSIS

Cost analyses for the alternative identified in Chapter 6 are detailed in this chapter. Alternative 1 assumes that all of the biosolids will be land applied in cake form. This chapter provides details on the assumptions used and the costs developed for this alternative scenario.

7.1 - LAND APPLICATION COST ANALYSIS

A cost estimate has been developed for land application of all biosolids in a dewatered form. This estimate is based on the use of spreader and tiller technologies and evaluates staffing requirements and operating and maintenance costs. Capital investments for moving stock are amortized over seven years and the liner system over ten years at 6.7 percent interest. Staffing requirements include one operator at the site, an operations and maintenance coordinator (part time), and a water/wastewater operations manager. The cost estimate also includes land or transportation costs since a site has not been identified.

The acreage required is based on the calculations shown in Chapter 4. The agronomic loading of this material to supply 200 pounds/acre of nitrogen will allow approximately seven dry tons/acre for Alternative 1. Four hundred acres (plus buffers) will be required the first year.

7.1.1 - Capital Costs

The capital cost is estimated to be \$203,400 and includes mobile equipment. The details of these costs are shown in Appendix A. Mobile equipment includes:

- Tractor
- Manure spreader (trailer unit)
- Front end loader
- Soil tilling unit

7.1.2 Operations and Maintenance Costs

Operations and maintenance costs include labor, equipment maintenance, fuel, hauling/transportation, monitoring, and permit fees. Maintenance is assumed to be 5 percent of the capital investment annually. Fuel is assumed to be available at \$0.80/gallon. Table 7-1 summarizes these costs.

**TABLE 7-1
OPERATIONS AND MAINTENANCE COST SUMMARY**

Labor	\$65,000
Maintenance	\$10,200
Fuel	\$32,000
Transportation/Hauling	\$91,000
Permits/Monitoring	\$10,000
Total	\$208,200

7.1.3 - Labor

Labor requirements are summarized in Table 7-2. Labor rates were assumed as follows. These rates include an overhead and fringe benefit rate of 46 percent of base salary.

Hourly Labor

Operations Manager	\$48.18/hr
O & M Coordinator	\$22.03/hr
Front end loader Operator	\$22.03/hr

**TABLE 7-2
LABOR REQUIREMENTS**

Operations Manager	0.1
O & M Coordinator	0.2
Operator	1

7.1.4 - Transportation Costs

There will be a cost associated with the transportation of biosolids from each of the communities to the biosolids application site. This can be accomplished with LCRA personnel

and equipment or by contract hauling. Considering the nature of the participating entities, it may be beneficial to initially contract out this portion of the work. Appendix A (Cost Estimates) uses a contract cost of \$2.50/mile (50 miles round trip) for the cost analysis. Also included is an estimate for using LCRA equipment and labor. This estimate does not include capital expenditure for a truck and trailer, so it is low. Operations for transport are assumed to occur seven days per week to avoid storage at plants. This may be modified as operations warrant.

7.1.5 - Annualized Costs

Table 7-3 shows a summary of the cost estimates. Spreadsheets defining all aspects of the land application program are included in Appendix A .

**TABLE 7-3
LAND APPLICATION COST SUMMARY**

Scenario	Quantity (dry tons)	Capital Costs	Annualized Capital	Annual O & M	Total Annual Cost	\$/dry ton	\$/wet ton	First year Acreage ¹
Dewatered	2,830	\$185,000	\$36,300	\$208,200	\$244,500	\$86.40	\$17.28	800

1 - Includes buffer, 400 acres without buffer

7.2 - COMPOSTING COST ANALYSIS

7.2.1 - Site Layouts

Figures 7-1 and 7-2 show conceptual site layouts for the two proposed aerated static pile composting facilities at the 7.5 and 15 dry ton per day capacities. These layouts have been used to form the basis of the cost analysis. Each of these layouts assumes good site conditions are available and that access is readily available to the site as previously discussed.

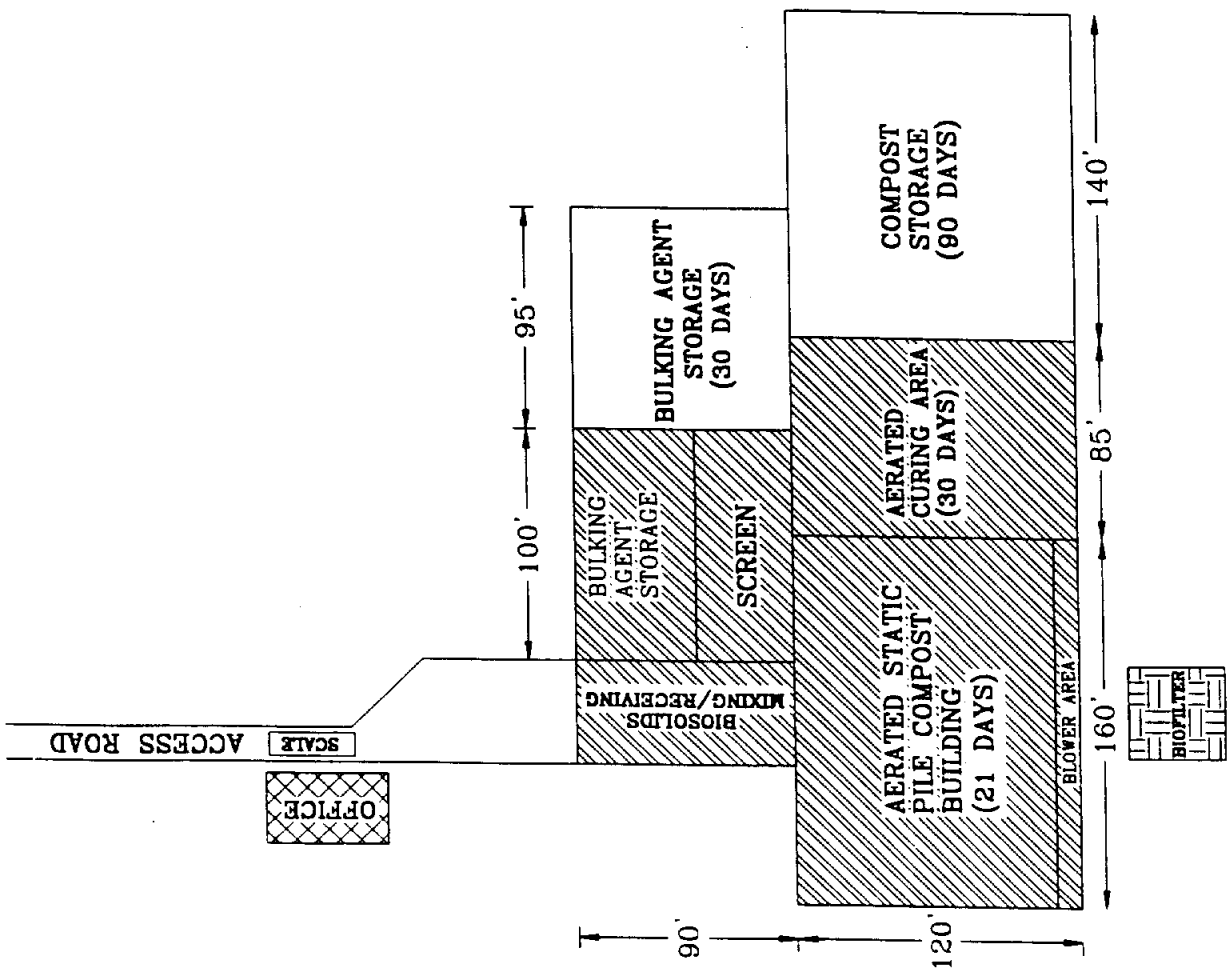

FIGURE 7-1 FACILITY LAYOUT -- AERATED STATIC PILE 7.5 DTPD

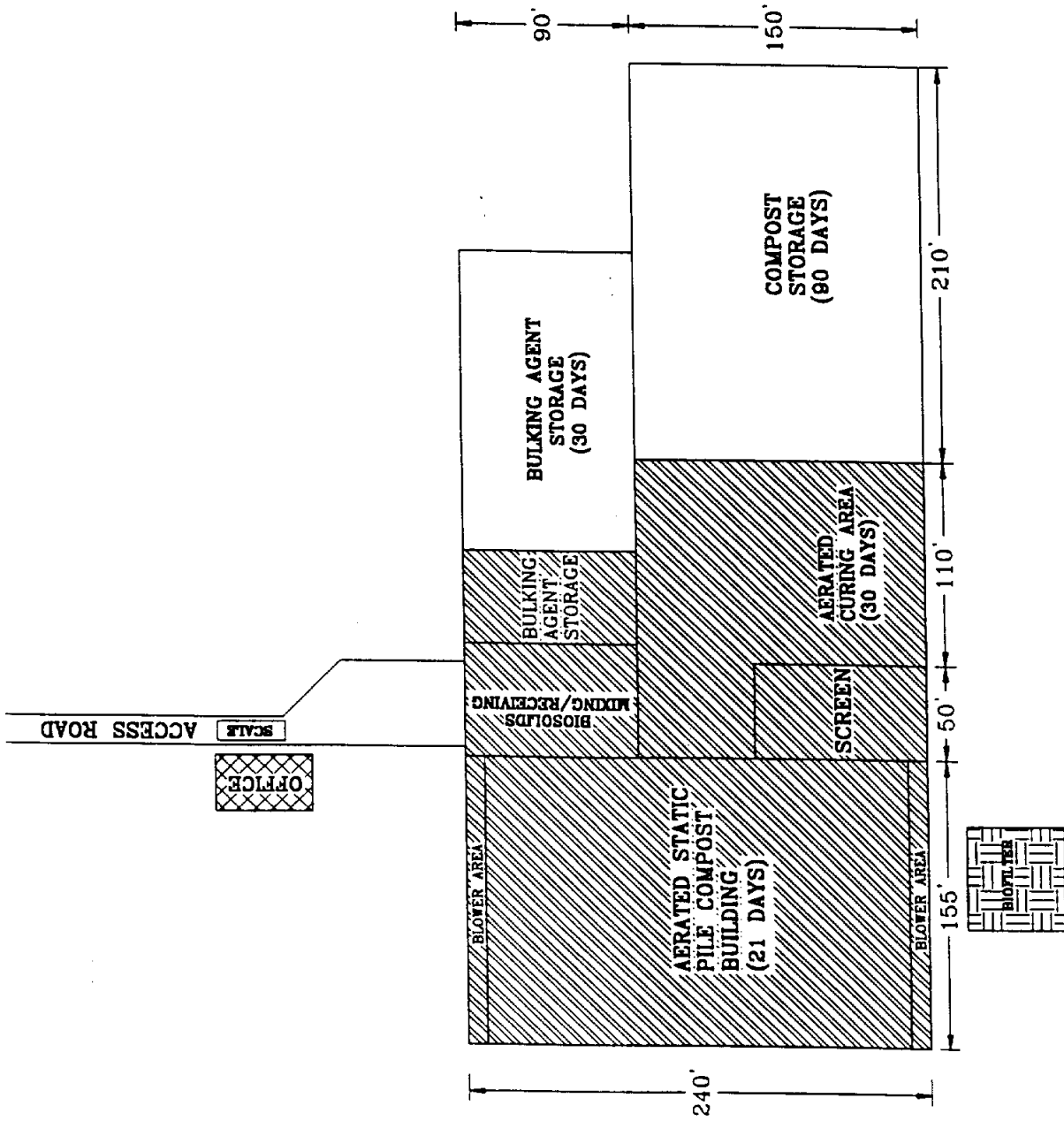

FIGURE 7-2 FACILITY LAYOUT -- AERATED STATIC PILE 15 DTPD

7.2.2 - Land Area Requirements

Table 7-4 shows projected land area requirements for the two composting facilities. Land area is determined using both a 200 foot and 500 foot perimeter buffer around all active materials handling, receiving, processing, composting, and storage areas. In actuality, when a specific site is determined, buffer area requirements will vary depending on adjacent land use, access, site geography, and climatography. The cost of land using a 500 foot buffer was added to the capital cost for both scenarios. The cost of land was not amortized since the land will retain its value and not depreciate.

**TABLE 7-4
LAND AREA REQUIREMENTS**

Size (DTPD)	Processing Area (Acres)	Processing Area + 200 foot setback (Acres)	Land Cost with 200 foot setback	Processing Area + 500 foot setback (Acres)	Land Cost with 500 foot setback
7.5	1.6	4.9	\$19,600	13.4	\$53,600
15	2.6	6.6	\$26,400	16.1	\$64,000

DTPD - Dry Ton Per Day

Assumes land cost of \$4,000 per acre

7.2.3 - Capital Costs

Capital costs for the two composting facilities are summarized in Table 7-5. Detailed cost analyses for each facility are included in Tables 7-6 and 7-7. Cost analyses include a detailed breakout of components as follows.

TABLE 7-5

CAPITAL COST SUMMARY

Size (DTPD)	Capital Cost	Cost per dry ton/per day capacity
7.5	\$3,180,000	\$424,000
15	\$4,925,000	\$328,300

DTPD = Dry Ton Per Day

7.2.3.1 - Sitework

Sitework includes general preparation of the site for construction activities including clearing and grubbing of the site, perimeter grading, site fencing, and final landscaping activities.

7.2.3.2 - Pads and Walls

This category includes all storage pads, roadways, floors, receiving and storage areas, concrete slabs, asphalt pads, and concrete push walls.

7.2.3.3 - Structures

This includes all pre-fabricated buildings associated with materials receiving and storage, mixing areas, composting area, screening area, curing and storage areas, as well as office areas at the facility.

7.2.3.4 - Odor Control

Components included in the odor control section include the ductwork, valving, and supports to convey compost process offgases to the odor control biofilter system. Blowers, humidification systems, supply fans, and the entire biofilter system are included in these cost estimates.

TABLE 7-6 CAPITAL COST ESTIMATE - LCRA AERATED STATIC PILE COMPOSTING FACILITY 7.5 DTPD

Item				
	Unit Cost	Unit	Quantity	Total Cost
SITE WORK				
Clear & Grub	\$5,200.00	Acre	3.0	\$15,630
Site Grading	\$0.75	SY	14,548	\$10,911
Site Fencing	\$12.85	LF	1,347	\$17,314
Final Landscaping	\$1.40	SY	7,274	\$10,183
Subtotal Sitework				\$54,038
PADS & WALLS				
Aeration Floor(Trenches and Concrete)	\$10.80	SF	12,851	\$138,791
Non-Trench Concrete Slab				
-Biosolids Receiving/Storage	\$5.25	SF	1,187	\$6,233
-Composting Area	\$5.25	SF	6,048	\$31,749
-Mixing Area	\$5.25	SF	3,000	\$15,750
-Blower Room	\$5.25	SF	1,718	\$9,020
Asphalt Pads				
-Screening Area	\$2.50	SF	4,000	\$10,000
-Curing Area	\$2.50	SF	11,088	\$27,720
-Amendment Storage	\$2.50	SF	10,731	\$26,826
-Product Storage	\$2.50	SF	16,504	\$41,260
-Access Roadways	\$2.50	SF	5,000	\$12,500
Concrete Pushwalls	\$220.00	LF	425	\$93,500
Subtotal Pads & Walls				\$413,349
STRUCTURES				
-Biosolids Receiving/Storage	\$10.00	SF	1,187	\$11,873
- Mixing Area	\$8.00	SF	3,000	\$24,000
- Composting Area	\$8.00	SF	18,899	\$151,188
- Screening Area	\$8.00	SF	4,000	\$32,000
- Curing Area	\$8.00	SF	11,088	\$88,704
- Amendment Storage	\$8.00	SF	1,219	\$9,755
-Blower Room	\$8.00	SF	1,718	\$13,744
- Office Area	\$40.00	SF	1,500	\$60,000
Subtotal Structures				\$391,264
ODOR CONTROL				
Ductwork/Valving/Supports	\$6,950	LS	1	\$6,950
Blowers	\$7,500.00	EA	1	\$7,500
Humidification System	\$4,940	LS	1	\$4,940
Biofilter(Earthwork,liner,media,irrigation, etc.)	\$20.00	SF	940	\$18,800
Subtotal Odor Control				\$38,190
STATIONARY EQUIPMENT				
Mix Box	\$95,000.00	LS	2	\$190,000
Compost Blowers Stations	\$4,600.00	EA	16	\$73,600
Tommel Screening System	\$145,000.00	LS	1	\$145,000
Curing Blowers Stations	\$1,550.00	LS	10	\$15,500
Control System	\$60,000.00	LS	1	\$60,000
Scale House	\$55,000.00	LS	1	\$55,000
Subtotal Stationary Equipment				\$539,100
MOBILE EQUIPMENT				
Front End Loader(5 CY)	\$150,000.00	EA	2	\$300,000
Steam Cleaner	\$5,000.00	EA	1	\$5,000
Subtotal Mobile Equipment				\$305,000
ON-SITE UTILITIES				
Leachate Collection	\$20.00	LF	1,447	\$28,947
Storm Water Collection/Siltation Pond	\$45,000.00	LS	1	\$45,000
Sanitary Sewer	\$20.00	LF	1,000	\$20,000
Electrical(7% of construction cost minus mobile equipment)	7%	LS	\$1,554,888	\$108,842
Water Service	\$25,000.00	LS	1	\$25,000
Subtotal Utilities				\$227,790
TOTAL OF ALL SUB TOTALS				
				\$1,968,730
CONTRACTOR OVERHEAD & PROFIT				
	15%	OF	\$1,968,730	\$295,310
OFF-SITE INFRASTRUCTURE IMPROVEMENTS				
	\$100,000	OF	1	\$100,000
CONTINGENCY				
	15%	OF	\$2,364,040	\$354,606
ENGINEERING/PERMITTING/CONSTRUCTION ADMINISTRATION				
	15%	OF	\$2,718,646	\$407,797
LAND (With 500' Buffer)				
	\$4,000	Acre	13.4	\$53,600
GRAND TOTAL				\$3,180,043

TABLE 7-7 CAPITAL COST ESTIMATE - LCRA AERATED STATIC PILE COMPOSTING FACILITY 15 DTPD

Item			Quantity	Total Cost
	Unit Cost	Unit		
SITE WORK				
Clear & Grub	\$5,200.00	Acre	4.4	\$22,984
Site Grading	\$0.75	SY	21,393	\$16,045
Site Fencing	\$12.85	LF	1,655	\$21,289
Final Landscaping	\$1.40	SY	10,697	\$14,975
Subtotal Sitework				\$76,273
PADS & WALLS				
Aeration Floor(Trenches and Concrete)	\$10.80	SF	24,886	\$288,768
Non-Trench Concrete Slab				
-Biosolids Receiving/Storage	\$5.25	SF	1,505	\$7,899
-Compost Floor	\$5.25	SF	11,711	\$81,483
-Mixing Area	\$5.25	SF	4,000	\$21,000
-Blower Room	\$5.25	SF	4,991	\$26,200
Asphalt pads				
-Screening Area	\$2.50	SF	5,000	\$12,500
-Curing Area	\$2.50	SF	15,876	\$39,190
-Amendment Storage	\$2.50	SF	18,309	\$45,773
-Product Storage	\$2.50	SF	29,352	\$73,381
-Access Roadways	\$2.50	SF	5,000	\$12,500
Concrete Pushwalls	\$220.00	LF	485	\$106,700
Subtotal Pads & Walls				\$676,394
STRUCTURES				
-Biosolids Receiving/Storage	\$10.00	SF	1,505	\$15,045
- Mixing Area	\$8.00	SF	4,000	\$32,000
- Composting Area	\$8.00	SF	36,597	\$292,778
- Screening Area	\$8.00	SF	5,000	\$40,000
- Curing Area	\$8.00	SF	15,876	\$125,408
- Amendment Storage	\$8.00	SF	2,081	\$16,645
- Blower Room	\$8.00	SF	4,991	\$39,924
- Office Area	\$40.00	SF	1,500	\$60,000
Subtotal Structures				\$621,798
ODOR CONTROL				
Ductwork/Vahing/Supports	\$13,500	LS	1	\$13,500
Blowers	\$7,500.00	EA	2	\$15,000
Humidification System	\$8,875	LS	1	\$8,875
Biofilter(Earthwork,liner,media,irrigation, etc.)	\$20.00	SF	1,875	\$37,500
Subtotal Odor Control				\$74,875
STATIONARY EQUIPMENT				
Mix Box	\$95,000.00	LS	3	\$285,000
Compost Blowers Stations	\$5,100.00	EA	20	\$102,000
Tommel Screening System	\$245,000.00	LS	1	\$245,000
Curing Blowers Stations	\$3,400.00	LS	14	\$47,600
Control System	\$80,000.00	LS	1	\$80,000
Scale House	\$55,000.00	LS	1	\$55,000
Subtotal Stationary Equipment				\$814,600
MOBILE EQUIPMENT				
Front End Loader(10 CY)	\$250,000.00	EA	1	\$250,000
Front End Loader(5 CY)	\$150,000.00	EA	2	\$300,000
Steam Cleaner	\$5,000.00	EA	1	\$5,000
Subtotal Mobile Equipment				\$556,000
ON-SITE UTILITIES				
Leachate Collection	\$20.00	LF	1,755	\$35,103
Storm Water Collection/Siltation Pond	\$45,000.00	LS	1	\$45,000
Sanitary Sewer	\$20.00	LF	1,000	\$20,000
Electrical(7% of construction cost minus mobile equipment)	7%	LS	\$2,387,044	\$167,093
Water Service	\$25,000.00	LS	1	\$25,000
Subtotal Utilities				\$292,196
TOTAL OF ALL SUB TOTALS				
				\$3,109,137
CONTRACTOR OVERHEAD & PROFIT	15%	OF	\$3,109,137	\$466,371
OFF-SITE INFRASTRUCTURE IMPROVEMENTS	\$100,000	OF	1	\$100,000
CONTINGENCY	15%	OF	\$3,675,508	\$551,326
ENGINEERING/PERMITTING/CONSTRUCTION ADMINISTRATION	15%	OF	\$4,226,834	\$634,026
LAND (With 600' Buffer)	\$4,000	Acre	16.1	\$64,400
GRAND TOTAL				\$4,926,269

7.2.3.5 - Stationary Equipment

This capital cost category includes all stationary equipment such as mix boxes, blower stations, screening system, scale house, and central computer control system.

7.2.3.6 - Mobile Equipment

This category includes front-end loaders.

7.2.3.7 - Utilities

Utilities which have been provided for in the cost analysis include water service, wastewater service or sanitary sewer, electrical service, and a stormwater collection siltation pond and leachate collection. Linear foot costs are used for leachate collection based on the facility capacity. A lump sum cost for constructing a siltation pond and collecting storm water has been used based on processing area size. Sanitary sewer lines are based on 1,000 feet on-site to the nearest sewer connection.

7.2.3.8 - Other

In addition to the above categories, a fee of 15 percent has been established for contractor overhead and profit. A 15 percent contingency, a lump sum of \$100,000 for off-site infrastructure improvements, and a 15 percent engineering, permitting, and construction administration fee have also been allowed.

The 15 percent contingency is a standard value obtained from R.S. Means Building Construction Cost Data for projects at the conceptual planning stage. This contingency includes unusual site conditions; weather conditions; local construction climate; availability of materials, equipment, and skilled labor; owner restrictions or requirements, and/or miscellaneous fees.

7.2.4 - Operations and Maintenance Costs

Table 7-8 shows the operations and maintenance costs associated with both facilities. Cost components for the facility operation include labor, electricity, fuel, equipment and biofilter maintenance, site maintenance, water, wastewater treatment, insurance, license fees and taxes,

and product monitoring. It is assumed that all of the bulking agent required will be ground yard waste delivered to the facility at a cost of \$2/CY to cover the haul cost. Revenues from the sales of compost at the facility as well as the costs associated with marketing composts are also not included in these costs but are addressed in Section 7.2.5. The following sections describe assumptions and rates used in the analyses.

**TABLE 7-8
OPERATIONS AND MAINTENANCE COST SUMMARY**

	7.5 DTPD	15 DTPD
Labor	\$161,000	\$267,000
Bulking Agent¹	\$41,000	\$82,000
Maintenance²	\$41,000	\$67,000
Fuel³	\$10,000	\$15,000
Utilities³	\$18,000	\$30,000
Miscellaneous⁴	\$15,000	\$20,000
Annual O & M Cost	\$286,000	\$481,000
Annual O & M Cost per Dry Ton of Biosolids Processed	\$147	\$123

DTPD - Dry tons per day of biosolids

1 - Assumes \$2/cy cost to transport ground yard waste to the site

2 - Includes equipment, site, and biofilter maintenance costs

3 - Based on estimated usage and \$.80 per gallon for fuel and \$.065/Kw-hr for electricity

4 - Includes insurance, licensing, laboratory analysis of product, and engineering consulting fees

7.2.4.1 - Labor

Labor rates were based on estimated hourly labor rates obtained from LCRA, including 46 percent for fringe benefits, and 150 hours per person for overtime. The hourly labor rates used are as follows:

Operations Manager	\$48.18/hr.
O & M Coordinator	\$22.03/hr.
Front End Loader Operator	\$22.03/hr.
Maintenance Person	\$15.01/hr.
Administrative Clerk	\$12.72/hr.
Laborer	\$12.41/hr.

Each facility size was analyzed to determine the labor requirements to accomplish the required process tasks. Table 7-9 shows the number of personnel required to operate the facility. In each option, a full-time scale operator/administrative person will be required to handle incoming and outgoing trucks and materials.

**TABLE 7-9
LABOR REQUIREMENTS**

	7.5 DTPD	15 DTPD
Operations Manager	0.1	0.1
O & M Coordinator	0.2	0.2
Front End Loader Operator	2	3
Laborer	0.5	1
Maintenance Person	0	1
Administrative Clerk	1	1

In each option, 10 percent of an operation manager's and 20 percent of an O & M Coordinator's time will be with the compost facility.

All facility operations and maintenance cost scenarios reflect the cost of a clerk and an operator for four hours on Saturdays to receive ground yard wastes, to load compost onto vehicles, and to collect compost revenues.

7.2.4.2 - Bulking Agent

It is assumed that the procurement of a bulking agent will not be required as enough ground yard wastes will be received at the facility from participating entities to meet bulking agent requirements. Approximately 20,500 cubic yards of ground yard wastes will be required

annually for the 7.5 DTPD facility and 41,000 cubic yards for the 15 DTPD facility. Section 5.2 discusses bulking agent availability in detail. A fee of \$2/CY was used to estimate costs to transport the ground yard waste to the facility

7.2.4.3 - Maintenance

Maintenance costs include equipment maintenance, site maintenance, and biofilter maintenance. Equipment maintenance includes three percent of the capital cost for all blowers, mix boxes, control systems, truck scale, steam cleaner, and basic HVAC equipment. It also includes five percent of the capital cost for the screening system and front-end loaders.

Site maintenance includes one percent of the capital cost for all structures and asphalt pads, as well as 15 percent of the capital cost for grounds maintenance. Biofilter maintenance includes monthly media testing and replacing media every three years.

7.2.4.4 - Fuel

Diesel fuel usage is based on five gallons per hour for front-end loaders. A rate of \$0.80 per gallon for diesel fuel obtained from LCRA was used.

7.2.4.5 - Utilities

Utilities include electricity, water, and wastewater treatment. Water and wastewater treatment will be minimal as an on-site pond will be used for biofilter irrigation. Electricity includes the composting and curing blowers operating 24 hours per day on an on/off time cycle, the biofilter blowers operating continuously 24 hours/day, and the mixing and screening systems operating 18 to 24 hours per week depending on size of the facility. An electrical rate of \$0.065 per kilowatt-hour was used.

7.2.4.6 - Miscellaneous

Miscellaneous costs include lab fees, consulting services, and administrative costs of insurance and license. Lab fees include quarterly testing of final compost product for metals and pathogens at \$400 per sample. A once per year TCLP analysis cost of \$1,200 is also included.

A fee of \$10,000 to \$15,000 for consulting services was included for the facilities depending on the size. Insurance and license costs of \$3,200 were also included for each option.

7.2.5 - Compost Marketing Costs and Revenues

Table 7-10 summarizes compost quantities expected to be produced for the two sized facilities, as well as revenues which could be expected through the sale of compost products. The revenues expected assume that marketing costs will be approximately \$1 per cubic yard of product and that revenues associated with compost sale will be between \$4 and \$6 per cubic yard. The resulting revenues as shown in Table 7-11 are based on a net revenue of between \$3 and \$5 per cubic yard of compost generated.

It should be noted that these are considered to be very conservative compost price figures. Based on the experience of other biosolids composting operations, the market may support a price double the \$4 to \$6 per cubic yard figure once the public becomes familiarized with the product.

TABLE 7-10
COMPOST PRODUCED MARKETING COSTS AND REVENUES

Quantities Produced (CY/Year)		Revenues,	
7.5 DTPD	15 DTPD	7.5 DTPD	15 DTPD
16,000	32,000	\$48,000 - \$80,000	\$96,000- \$160,000

¹Assumes \$1 per cubic yard for product marketing and between \$4 and \$6 per cubic yard for revenues due to product sales.

DTPD = Dry Ton Per Day

7.2.6 - Annualized Costs

Annualized costs for the two facility sizes evaluated are summarized in Table 7-11. Total annualized costs include amortized capital costs, direct operating costs, and land acquisition costs. A 6.7 percent interest rate was used on all amortized capital. A 20-year period was used for site work, buildings, engineering, permitting, and land. Moving stock, such as front-end loaders, was amortized over a period of seven years. Stationary equipment such as mixers was amortized

over a 10-year period. Annualized costs reflect the cost of equipment replacement by assigning an annual cost for borrowing money at a 6.7 percent interest rate to purchase equipment at the replacement interval indicated. The impact of compost sales revenue using the conservative values shown in Section 7.2.5 is shown as well.

TABLE 7-11
AERATED STATIC PILE COMPOSTING
ESTIMATED ANNUALIZED COSTS

	7.5 DTPD	15 DTPD
Amortized Capital	\$347,000	\$538,000
Annual O & M Cost	\$286,000	\$481,000
Total Annualized Cost	\$633,000	\$1,019,000
Annualized Cost Per Dry Ton Biosolids Processed	\$325	\$261
Annual Compost Sales Revenue	\$80,000	\$160,000
Adjusted Annualized Cost	\$553,000	\$859,000
Annualized Cost Per Dry Ton Biosolids Processed With Compost Sales	\$284	\$220

8.0 - RECOMMENDATIONS/IMPLEMENTATION STEPS

Table 8-1 summarizes biosolids management costs for existing programs as well as the two alternatives evaluated as part of this study. The average unit cost of existing programs is approximately \$180 per dry ton. Land application of biosolids in a cake form will be approximately one half of that unit cost. Composting using a covered aerated static pile technology would cost approximately 40 percent higher on average. However, the benefit of composting is that a more versatile product would be produced for distribution in the multiple market places, and the use of other wastes generated by participating entities (yard waste and clean wood waste) could be incorporated into the composting program, thereby reducing overall solid waste management costs to the participating entities. Approximately half of the participating entities have unit costs that are significantly higher than the average unit cost of \$180 per dry ton and approximately half have unit costs which are significantly less than the overall average.

At this point in the evaluation process, a determination needs to be made by each of the participating entities as to their level of interest to participate in a regional program. Preferences with regards to participating in a regional land application program or a regional composting program need to be ascertained. During a review meeting it was recognized that land application programs, although being lower in overall unit cost, would require significantly greater amount of land area, and therefore, the long term viability of such a program raised questions in many of the participating entities' minds. It appears that there is a significant amount of interest in composting even though the unit costs may be somewhat higher due to the long term viability of developing such a program and due to the smaller land area requirements. After determining the level of interest of the various participating entities, a technology needs to be selected for further evaluation and development of a conceptual design. At that point, the public education process should be initiated for siting of either the land application or composting facilities.

Both technologies require the following issues to be addressed as part of conceptual design:

- Dewatering - Three of the ten participating entities currently do not have dewatering equipment available to them. All three are in the process of evaluating dewatering options. The dewatering of biosolids is necessary for both land application and

composting to be economically viable in the LCRA study area. The use of either mobile dewatering equipment, stationary dewatering equipment, or hauling of liquid to an adjacent facility for dewatering needs to be evaluated, designed, and implemented.

- **Transportation** - Dewatered biosolids cake from the participating entities would need to be transported to either a land application site or a composting facility. At this point in time it may be most viable to develop a contract hauling agreement for trucking of dewatered biosolids to the planned facilities. This way, capital outlay is minimized and as the program develops over time, it can be easily tailored to meet the needs of participating entities.
- **Storage** - Storage of biosolids at the existing wastewater treatment facilities is a crucial issue in particular as related to a land application program. The amount of storage available on-site will determine the frequency of dewatering and also the schedule that dewatered biosolids or sand dried biosolids would be available for transport to regional facilities. Scheduling of operations would need to be addressed as well as determining the amount of storage which needs to be provided for at either a land application or composting site.
- **Contract Agreements** - The development of agreements between participating entities and LCRA would need to be initiated at this stage in the process. It is important to solicit the political feedback necessary to ascertain critical design and contractual issues that may have impact on the facility design and operation. Draft agreements would simply begin the agreement process and provide feedback before the next stage of the program is developed.

Land Application issues which would affect land application that need to be addressed as part of the implementation program.

- **Agreements** would need to be developed between LCRA and farmers for the use of their farmland. Cropping practices, schedules, and other issues would need to be formalized in this process.
- **Public education** about land application sites would need to be initiated.
- **Permitting** - The permitting process with the State of Texas would need to be initiated at this stage in program development.
- **Storage** - The quantity of material required for storage will dictate the size of the storage area for use in a land application program. The location of such a storage facility would need to be determined at this stage in the process so that a more accurate hauling costs and site development costs could be determined.

The following items are specific to the needs of development of a composting program.

- **Bulking agents identified in this study** - One of the key potential bulking agents appears to be yard waste or clean wood wastes available from participating entities. The exact quantity and form of bulking agents availability from the participating entities needs to be more comprehensively evaluated. In addition, logistics of delivering ground yard wastes to a central compost facility would need to be worked out. The cost estimates developed in this study assume that yard wastes were shredded or ground at the community level and then delivered to the compost site in a shredded form. If additional shredding is required, the costs associated with such a program would also need to be assessed.
- **Site selection** - The compost technology evaluated as part of this study assumed a covered aerated static pile technology is suitable. Once several potential sites have been determined that would meet the sizing and general location requirements, modeling work should be performed to assess the level of odor control necessary to minimize any odor impacts on adjacent land owners. This effort would be necessary to determine the suitability of the technology chosen.
- **Market development** - With a composting program, the development of compost markets should be initiated. As the study pointed out, a significant demand for composted products is available in the Travis and Williamson County areas. Continued dialog is necessary between the generator of compost and the potential users so that compost value is optimized and any user concerns which may have impact on design of a full scale facility can be ascertained.

The possibility of developing a program in a phased fashion also warrants further investigation. A program for land application typically can be developed in a shorter time frame and with less capital investment than a regional composting program. It is possible to initiate a program whereby land application is practiced in the near term, while a compost facility is designed and constructed. Similarly, if only a small portion of the entities involved in this study decide to participate, a smaller tract of land for land application could be developed initially and allowing for future growth as other entities join the program.

It is also a common practice to build a smaller composting facility with the potential for expansion as biosolids production increases or as additional communities are solicited to bring materials to the site. The smaller sized 7.5 dry ton per day capacity biosolids composting facility

would provide capacity for a little bit more than one half of the biosolids production currently generated.

**TABLE 8-1
BIOSOLIDS MANAGEMENT
COST COMPARISON**

	Approximate Total Annual Cost	Average Unit Cost (\$/Dry Ton)
Existing Programs	\$509,400	\$180
Alternative 1		
Land Apply all Biosolids	\$244,500	\$86.40
Alternative 2		
Compost all Biosolids	\$721,650	\$255

- Notes: 1. Based on 2,830 dry tons/year
2. Assumes all biosolids are dewatered using belt filter presses or drying beds

APPENDIX A

LCRA Land Application Cost Estimates - Scenario 1, Land Apply All Biosolids					
assumptions:		transportation distance of 25 miles each way			
		no land costs have been included			
		labor required will include:			hourly rate
		1 operator for the truck/tractor			\$ 15.09
		0.1 water and wastewater operations manager			\$ 33.00
		0.2 O&M coordinator			\$ 15.09
		1.46 overhead multiplier			
Quantity					
	2830	dry tons per year at	20%	solids	
	14,150	wet tons/yr at 20% solids		15,722	cubic yards/year @ 20% solids
				3,183,750	gallons per year
	7	dry tons per acre			
	404	acres for first year of application, buffers not included			
Equipment Selection					
Knight Industrial Biosolids Spreader (for dewatered biosolids)					
requires a tractor for pulling each piece of equipment and a unit for diking					
dewatered material into the soil					
1 front end loader					
1 Knight Industrial Biosolids Spreader dewatered biosolids					
	27	cubic yard capacity		15,722	cubic yards/year
	2	loads per day		60	cy/day, 5 days/week
	\$ 40,000	per spreader unit		23,364	ft ² for storage
	\$ 50,000	per tractor or truck		\$ 1.00	per ft ² for liner
	\$ 80,000	per front end loader			
	\$ 23,364	for liner under storage area			
	\$ 10,000	per diskier unit			
subtotal	\$ 203,364				
total	\$ 203,364				
salary & overhead					
	1	operator		operator	\$ 45,825 per year
	0.1	manager		manager	\$ 10,021 per year
	0.2	O&M coordinator		O&M coordinator	\$ 9,165 per year
	40,000	gallons of fuel per year			
	\$ 0.80	per gallon		annual fuel cost	\$ 32,000 per year
	\$10,000	annual monitor/permit		annual monitoring cost	\$10,000 per year
	\$ 91,000	annual transport cost		annual trans cost	\$ 91,000 per year
	7	year amm. (moving equip)		moving equipment	\$33,051 per year
	10	year amm. (liner)		liner	\$3,281 per year
	6.7%	annual interest		annual maintenance	\$10,168
	5%	maintenance cost		total	\$ 244,512 per year
					\$ 86.40 per dry ton
					\$ 17.28 per wet ton
					\$ 76.80 per 1000 gallons

assuming contract hauling	\$2.50	per mile			
	50	miles per trip			
	2	trips per day, 7 days per week, 52 weeks per year			
	\$91,000	per year			

\$/wet ton and dry ton for transportation of biosolids 50 miles per day (25 one way) using LCRA equipment and labor

	1.46	overhead multiplier			
--	-------------	----------------------------	--	--	--

labor costs					
	wage	adj wage	hours	\$/trip	
	\$ 15.09	\$ 22.03	4	\$ 88.13	

fuel costs					
	miles/trip	miles/gal	gal/trip	\$/gallon	\$/trip
	50	7	7.1	\$ 0.80	\$ 5.71

O&M costs for truck and trailer					
truck					
	parts annually	\$500			
	labor rate	adj labor	hours/yr	\$/year	\$/trip
	\$ 10.82	\$ 15.80	150	\$2,869.6	\$ 7.47

trailer					
	parts annually	\$200			
	labor rate	adj labor	hours/yr	\$/year	\$/trip
	\$ 10.82	\$ 15.80	40	\$ 831.9	\$ 2.17

				total	\$ 103.48	per trip
					22	wet tons per trip
					\$ 4.70	per wet ton
					20%	solids
					\$ 23.52	per dry ton
					2830	dry tons per year
					\$ 66,556	per year

LCRA Land Application Acreage Needs Calculation - 5 year needs								
agronomic loading								
200	lb N/acre							
7	dt/acre							
2831	dt/yr - scenario 1		236	dry tons per month				
20%	mineralization rate		1180	wet tons per month				
20%	solids		1311	cy per month				
			availabiliit	subsequent year availability (lb N/dry ton)				
inorgani	% organic	mineral	lb N/dt	years				
N	N	rate	year 1	2	3	4	5	
0.3%	5.6%	20%	28.4	8.8	3.3	1.1	1.1	
			scenario 1					
	lb/dt avail.	dt/acre	acres	new acres				
year 1	28.4	7.0	402					
year 2	37.2	5.4	497	95				
year 3	40.5	4.9	545	48				
year 4	41.6	4.8	569	25				
year 5	42.7	4.7	587	18				
area needed for storage of three months of production								
	1311	cy per month						
	3933	cy per 3 month period						
	1.1	fluctuatuion multiplier						
	4327	cy of storage needed						
	5	feet pile depth						
	23,364	square feet of area needed						
	0.54	acres						

APPENDIX B



TEXAS WATER DEVELOPMENT BOARD

William B. Madden, *Chairman*
Charles W. Jenness, *Member*
Lynwood Sanders, *Member*

Craig D. Pedersen
Executive Administrator

Noé Fernández, *Vice-Chairman*
Elaine M. Barrón, M.D., *Member*
Charles L. Geren, *Member*

October 29, 1996

Mr. Joseph J. Beal
Manager, Water and Hydroelectric Company
Lower Colorado River Authority
P.O. Box 220
Austin, Texas 78767-0220

Re: Review Comments for a Draft Report for Texas Water Development Board (Board)
Regional Wastewater Planning for the Lower Colorado River Authority (Authority),
TWDB Contract Number 96-483-164

Dear Mr. Beal:

Staff members of the Texas Water Development Board have completed a review of the draft report under TWDB Contract No. 96-483-164. The comments in Attachment 1 should be considered before the report is finalized.

The Board would like to proceed toward completion of this study as soon as possible.

The Board looks forward to receiving the Final Report on this planning project. Please contact Mr. Gordon Thorn, the Board's Contract Manager, at (512) 463-7979, if you have any questions about the Board's comments.

Sincerely,

A handwritten signature in black ink, appearing to read "Tommy Knowles".

Tommy Knowles
Deputy Executive Administrator
for Planning

cc: Gordon Thorn, TWDB
Michael H. Tomme, P.E.

Our Mission

Exercise leadership in the conservation and responsible development of water resources for the benefit of the citizens, economy, and environment of Texas.

P.O. Box 13231 • 1700 N. Congress Avenue • Austin, Texas 78711-3231
Telephone (512) 463-7847 • Telefax (512) 475-2053 • 1-800- RELAY TX (for the hearing impaired)
URL Address: <http://www.rwdb.state.tx.us> • E-Mail Address: info@rwdb.state.tx.us

♻️ Printed on Recycled Paper ♻️

ATTACHMENT 1

"Biosolids Land Application and Composting Feasibility Study"

Table 2-3 shows a copper concentration characteristic of Brushy Creek biosolids which is higher than the Grade I compost value. This appears to contradict the statement on page 5, "Further, metals concentrations of all the biosolids are below Grade I compost maximum levels".

The report is consistent with 30 Texas Administrative Code (TAC) Chapter 312 and Chapter 330 rules and 40 Code of Federal Regulations (CFR) Part 503, well documented and hopefully will be implemented.

**LOWER COLORADO RIVER AUTHORITY
TRAVIS AND WILLIAMSON COUNTIES**

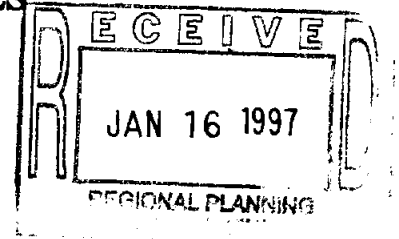

**BIOSOLIDS LAND APPLICATION AND COMPOSTING
FEASIBILITY STUDY**

November 13, 1996

FINAL REPORT

Prepared for:
Lower Colorado River Authority
P.O. Box 220
Austin, Texas 78767-0220
(512) 473-3333

Prepared by:
E&A Environmental Consultants, Inc.
1130 Kildaire Farm Road, Suite 200
Cary, North Carolina 27511
(919) 460-6266

E & A Environmental Consultants, Inc.

**LOWER COLORADO RIVER AUTHORITY
TRAVIS AND WILLIAMSON COUNTIES**

**BIOSOLIDS LAND APPLICATION AND COMPOSTING
FEASIBILITY STUDY**

November 13, 1996

FINAL REPORT

Prepared for:
Lower Colorado River Authority
P.O. Box 220
Austin, Texas 78767-0220
(512) 473-3333

Prepared by:
E&A Environmental Consultants, Inc.
1130 Kildaire Farm Road, Suite 200
Cary, North Carolina 27511
(919) 460-6266

(This report is printed on recycled paper).

TABLE OF CONTENTS

	<u>Page</u>
EXECUTIVE SUMMARY	i
Table 1 - Biosolids Management Cost Comparison	iii
 CHAPTER 1	
1.0 - INTRODUCTION	1
 CHAPTER 2	
2.0 - BIOSOLIDS GENERATION DATA	2
Table 2-1 - Estimated Sludge/Biosolids Generation From Participating Communities	4
Table 2-2 - Sludge Generation Rates per Million Gallons Sewage Treated ...	5
Table 2-3 - June 1996 Biosolids Chemical Characteristics for Participating Entities	after Pg. 5
 CHAPTER 3	
3.0 - REGULATORY REVIEW	6
3.1 - EPA PART 503 REGULATIONS	6
3.1.1 - Metal Constituent Concentrations	6
Table 3-1 - EPA Biosolids Pollutant Level Limits	7
3.1.2 - Pathogen Reduction Classification	7
Table 3-2 - Pathogen Reduction Criteria/Management Practices	9
Table 3-3 - Pathogen Reduction Alternatives for Class A Compost	10
3.1.3 - Vector Attraction Criteria	10
Table 3-4 - Summary of Options for Meeting Vector Attraction Reduction ...	11
3.1.4 - Monitoring, Record Keeping, and Reporting Requirements	11
Table 3-5 - Monitoring Frequency	11
Table 3-6 - Land Application Record Keeping Requirements	12
3.2 - TNRCC CHAPTER 312 REGULATIONS FOR SLUDGE USE, DISPOSAL, AND TRANSPORT	12
Table 3-7 - Annual Transportation Fee	13
3.2.1 - Public Notice for Land Application Projects	14
3.3 - TNRCC CHAPTER 332 REGULATIONS FOR BIOSOLIDS COMPOSTING .	15
Figure 1	18
Table 1 - Maximum Allowable Concentrations	18
Figure 2	19
Table 2 - Maturity and Stability	19
Figure 3	19
Table 3 - Additional Final Product Standards	19
3.3.1 - Composting Facility Public Notice Requirements	19

CHAPTER 4

4.0 - TECHNOLOGY ASSESSMENT 21

4.1 - OVERVIEW OF LAND APPLICATION TECHNOLOGIES 21

 Table 4-1 - Advantages and Disadvantages of Land Application 23

4.2 - LAND APPLICATION TECHNOLOGIES ASSESSMENT 23

4.2.1 - Area Requirements 23

 Table 4-2 - Nitrogen Uptake of Agricultural Crops 23

 Table 4-3 - Estimates of Ammonia Nitrogen Retained After Application 24

 Table 4-4 - Summary of Biosolids Land Application Quantities Per Acre 25

4.2.2 - Site and Utility Requirements 25

4.2.3 - Capital and Operating Costs 26

4.2.4 - Environmental Controls 26

4.2.5 - Staffing 26

4.2.6 - Summary of Comparable Biosolids Land Application Programs 27

 Table 4-5 - Land Application Facilities 28

4.3 - OVERVIEW OF COMPOSTING TECHNOLOGIES 29

4.3.1 - Process Overview 29

4.3.2 - Bulking Agents 31

4.3.3 - Composting Systems 32

 Figure 4-1 - Composting Generalized Flow Diagram after Pg. 33

 Table 4-6 - Advantages and Disadvantages of Windrow Composting 34

 Table 4-7 - Advantages and Disadvantages of Aerated Static Pile Composting 35

 Table 4-8 - Advantages and Disadvantages of Agitated Bed Composting Systems 36

4.3.3.1 - Windrow Composting Systems 36

 Figure 4-2 - Windrow Composting System after Pg. 36

4.3.3.2 - Aerated Static Pile Systems 37

4.3.3.3 - In-Vessel Composting Systems 38

 Figure 4-3 - Extended Aerated Static Pile Composting after Pg. 38

4.4 - COMPOSTING TECHNOLOGIES ASSESSMENT 39

 Figure 4-4 - Agitated Bed Typical Configuration after Pg. 39

4.4.1 - Area Requirements 40

 Table 4-9 - Compost Facility Land Area Requirements 40

4.4.2 - Site and Utility Requirements 41

4.4.3 - Capital and Operating Costs 42

4.4.4 - Environmental and Odor Control 43

4.4.5 - Staffing Requirements 45

 Table 4-10 - Compost Facility Staffing Requirements 45

4.4.6 - Summary of Comparable Biosolids Composting Facilities 46

4.4.6.1 - Aerated Agitated Bed Facilities 46

 Table 4-11 - Compost Facility Summary after Pg. 46

4.4.6.2 - Aerated Static Pile Facilities 47

4.4.6.3 - Un-aerated Windrow Facilities 48

4.4.6.4 - Aerated Windrow Facilities 49

4.5 - COMPARISON OF LAND APPLICATION VS. COMPOSTING	49
Table 4-12 - Advantages and Disadvantages of Land Application vs. Composting	51

CHAPTER 5

5.0 - MARKET RESEARCH	52
5.1 - LCRA BIOSOLIDS COMPOST MARKETING RESEARCH	52
5.1.2 - Market Segments	52
5.1.2.1 - Landscapers	53
5.1.2.2 - Growers	54
5.1.2.3 - Garden Centers	54
Table 5-1 - Retail Compost Prices - Bulk	55
Table 5-2 - Retail Compost Prices - Bagged	56
5.1.2.4 - Landscape Materials Suppliers	56
Table 5-3 - Wholesale Compost Prices - Bulk	57
5.1.3 - Current Estimated Compost Demand	58
Table 5-4 - Preliminary Current Compost Use Estimates for the Travis and Williamson County Area	58
5.1.4 - Competing Products	58
5.1.5 - Conclusions	59
5.2 - BULKING AGENT SOURCES FOR COMPOSTING	60
5.2.1 - Bulking Agent Requirements	60
5.2.2 - Local Bulking Agent Availability	61
Table 5-5 - Potential Bulking Agent Sources	62
5.3 - POTENTIAL LAND RESOURCES FOR LAND APPLICATION/COMPOSTING	65
Site Investigation Study Area 1	after Pg. 65
Site Investigation Study Area 2	after Pg. 65
5.3.1 - Land Requirements	66
5.3.2 - Land Related Issues	66
5.3.3 - Available Land	67

CHAPTER 6

6.0 - PRELIMINARY DESIGN	70
6.1 - ALTERNATIVES SECTION	70
6.2 - LAND APPLICATION DESIGN CRITERIA	72
Table 6-1 - Annual Dry Tons Generated	72
Table 6-2 - Acreage Needed for Application of Biosolids W/28.4 Lb. Available Nitrogen/Dry Ton	73
Table 6-3 - Residual Nitrogen Due to Previous Application	74
6.2.2 - General Design Criteria	74
6.2.2.1 - Material Transport	74

6.2.2.2 - Material Storage	74
Table 6-4 - Typical Crop Rotations and Wet Month Rainfall in the Travis and Williamson County Areas	75
6.2.2.3 - Operating Schedules	75
6.2.2.4 - Side Condition Assumptions	76
6.2.2.5 - Applying	76
6.3 - COMPOSTING DESIGN CRITERIA	77
6.3.1 - Biosolids Processing Capacity	77
6.3.2 - General Composting Design Criteria	78
6.3.2.1 - Materials Transport	78
6.3.2.2 - Materials Delivery, Receiving, and Storage	78
6.3.2.3 - Operating Schedules	79
6.3.2.4 - Site Condition Assumptions	79
6.3.2.5 - Odor Control Technology	79
6.3.3 - Aerated Static Pile Composting Facility	80
6.3.3.1 - Biosolids Receiving	80
6.3.3.2 - Yard Waste Receiving/Processing	80
Figure 6-1 - Aerated Static Pile Process Flow Diagram	after Pg. 80
6.3.3.3 - Mixing	81
6.3.3.4 - Composting	81
Figure 6-2 - Aerated Static Pile Typical Extended Pile Configuration Cross Section	after Pg. 81
Figure 6-3 - Aerated Static Pile Typical Extended Pile Configuration Isometric	after Pg. 81
6.3.3.5 - Screening	82
6.3.3.6 - Curing and Storage	82
6.3.3.7 - Materials Balances	82
Table 6-5 - Materials Balance for LCRA 7.5 Dry Tons Per Day Aerated Static Pile	after Pg. 82
Table 6-6 - Materials Balance for LCRA 15 Dry Tons Per Day Aerated Static Pile	after Pg. 82
Figure 6-4 - Bulking Agent to Biosolids Ratio as a Function of Solids Concentration (Volumetric)	after Pg. 83
Figure 6-5 - Bulking Agent to Biosolids Ratio as a Function of Solids Concentration (Gravimetric)	after Pg. 83

CHAPTER 7

7.0 - COST ANALYSIS	84
7.1 - LAND APPLICATION COST ANALYSIS	84
7.1.1 - Capital Costs	84
7.1.2 - Operations and Maintenance Costs	84
Table 7-1 - Operations and Maintenance Cost Summary	85

7.1.3 - Labor	85
Table 7-2 - Labor Requirements	85
7.1.4 - Transportation Costs	85
7.1.5 - Annualized Costs	86
Table 7-3 - Land Application Cost Summary	86
7.2 - COMPOSTING COST ANALYSIS	86
7.2.1 - Site Layouts	86
Figure 7-1 - Facility Layout - Aerated Static Pile 7.5 DTPD	after Pg. 86
Figure 7-2 - Facility Layout - Aerated Static Pile 15 DTPD	after Pg. 86
7.2.2 - Land Area Requirements	87
Table 7-4 - Land Area Requirements	87
7.2.3 - Capital Costs	87
Table 7-5 - Capital Cost Summary	88
7.2.3.1 - Sitework	88
7.2.3.2 - Pads and Walls	88
7.2.3.3 - Structures	88
7.2.3.4 - Odor Control	88
Table 7-6 - Capital Cost Estimate - LCRA Aerated Static Pile Composting Facility 7.5 DTPD	after Pg. 88
Table 7-7 - Capital Cost Estimate - LCRA Aerated Static Pile Composting Facility 15 DTPD	after Pg. 88
7.2.3.5 - Stationary Equipment	89
7.2.3.6 - Mobile Equipment	89
7.2.3.7 - Utilities	89
7.2.3.8 - Other	89
7.2.4 - Operations and Maintenance Cost	89
Table 7-8 - Operations and Maintenance Cost Summary	90
7.2.4.1 - Labor	90
Table 7-9 - Labor Requirements	91
7.2.4.2 - Bulking Agent	91
7.2.4.3 - Maintenance	92
7.2.4.4 - Fuel	92
7.2.4.5 - Utilities	92
7.2.4.6 - Miscellaneous	92
7.2.5 - Compost Marketing Costs and Revenues	93
Table 7-10 - Compost Produced Marketing Costs and Revenues	93
7.2.6 - Annualized Costs	93
Table 7-11 - Aerated Static Pile Composting Estimated Annualized Costs	94
CHAPTER 8	
8.0 - CONCLUSIONS	95
Table 8-1 - Biosolids Management Cost Comparison	98

APPENDIX A

LCRA Land Application Cost Estimates - Scenario 1, Land Apply All Biosolids

APPENDIX B

Texas Water Development Board Comments

**LOWER COLORADO RIVER AUTHORITY
TRAVIS AND WILLIAMSON COUNTIES
BIOSOLIDS LAND APPLICATION AND COMPOSTING
FEASIBILITY STUDY**

EXECUTIVE SUMMARY

The continued public health and safety, environmental quality, and economic well being of the rapidly growing Williamson and Travis Counties (Austin, Texas area) will depend on the availability of reliable, high quality wastewater treatment facilities of adequate capacity. Population growth in this region is expected to double in only ten year's time. Proper management of wastewater treatment process biosolids is an essential and challenging component of local government efforts to provide quality wastewater services. Land application and composting are two methods of beneficially using biosolids in an environmentally and economically acceptable manner. The Lower Colorado River Authority (LCRA) commissioned a study to evaluate the feasibility of developing a regional biosolids treatment and management project. Such a program would serve wastewater treatment plants in Southern Williamson and Northern Travis Counties. Ten communities and Municipal Utility Districts (MUDs) participated in the regional study with LCRA. They include:

Anderson Mill MUD	Leander
Brushy Creek MUD	Lost Creek MUD
Cedar Park	Manor
Georgetown	Pflugerville
Lakeway MUD	Round Rock

The primary objective of this study was to determine the viability of a regional program for beneficial use of biosolids and to recommend specific alternatives for implementation. The two technologies which were evaluated as part of this effort were land application and composting.

The primary material which is to be land applied or composted at a planned regional facility is dewatered biosolids. Presently, approximately eight dry tons of biosolids are generated

daily by the participating entities. The majority of the participants in this study have either belt filters or drying beds available for dewatering of biosolids. Three of the smaller to medium sized entities do not have dewatering facilities but are currently investigating dewatering alternatives as a means of minimizing their biosolids management costs. The biosolids generated by the participating entities have pollutant concentrations below state and federal exceptional quality standards. This indicates a high suitability for either land application or composting of these biosolids. Yard wastes and clean wood wastes which are currently generated by the participating entities appear to be available in abundant quantities for use as a bulking agent in a composting program should that be developed. A significant amount of farmland exists primarily in Eastern Williamson County and Northern Travis County for potential use as land application sites.

Table 1 Summarizes the costs associated with the land application and composting alternatives evaluated as compared to the overall average biosolids management costs currently experienced by the participating entities. The range of costs currently reported is extremely wide, between \$21 and \$2,600 per dry ton of biosolids managed. Of the ten entities, approximately one half have costs which are lower than the \$180 per dry ton average and approximately half have costs higher than the overall average. Smaller communities without dewatering equipment typically have higher costs with the larger facilities that have dewatering equipment installed having some of the lower costs. Most of the municipalities with lowest costs are landfilling biosolids and not beneficially using them. Capital costs associated with developing a land application program are on the order of \$200,000. Capital costs associated with developing a covered aerated static pile composting facility range between \$3.2 and \$4.9 million dollars. However, the land application program will require at least 800 acres to accommodate all of the biosolids generated, whereas a biosolids composting facility will require only 14 acres.

A phased approach can be utilized for the development of a regional facility using either of the two technologies or both technologies in a combined program. Critical issues which remain in order to develop a regional biosolids management program include:

- Time frame of implementation.
- Economic feasibility for each potential participant.
- Which entities are willing to participate.
- Identification and selection of potential sites.
- Establishing suitable transportation for dewatered biosolids and/or bulking agent if necessary.
- Establishment of agreements between participating entities and LCRA

**TABLE 1
BIOSOLIDS MANAGEMENT
COST COMPARISON**

	Approximate Total Annual Cost	Average Unit Cost (\$/Dry Ton)
Existing Programs	\$509,400	\$180
Alternative 1 Land Apply all Biosolids	\$244,500	\$86.40
Alternative 2 Compost all Biosolids	\$721,650	\$255

- Notes: 1. Based on 2,830 dry tons/year
2. Assumes all biosolids are dewatered using belt filter presses or drying beds

1.0 - INTRODUCTION

The Lower Colorado River Authority (LCRA) received a planning grant from the Texas Water Development Board to study the feasibility of developing a regional biosolids treatment and disposal project. Such a program would serve wastewater treatment plants (WWTP's) in Southern Williamson and Northern Travis Counties. Ten communities or Municipal Utility Districts participated in the regional study with LCRA. Twelve WWTP's generate biosolids for potential reuse from these participating entities. The purpose of this study is to determine whether a regional program for beneficial reuse of biosolids is viable and to recommend specific alternatives for implementation. The two technologies which were determined at the outset of the project to be potentially viable include land application and composting. This study summarizes the results of this work effort. The following work elements were performed in the effort:

- Review of biosolids, quantity and quality, generated by the 12 WWTP's
- Review of U.S. EPA Part 503 and Texas National Resource Conservation Commission (TNRCC) Sludge Use Disposal Transportation and Composting Rules
- Technology assessment of land application and composting
- Market research on bulking agent supply, compost markets, and land resources available for such a project
- Preliminary design for land application and composting
- Detailed cost analysis
- Recommendations

2.0 - BIOSOLIDS GENERATION DATA

The ten participating entities (communities or Municipal Utility Districts) were surveyed to determine existing biosolids quantities, management practices, and costs. Table 2-1 summarizes the results of this survey effort. Written data was solicited from each participant and then followed up by telephone interview where necessary to validate data.

Approximately 2,830 dry tons of biosolids are generated annually (1995) from the 12 wastewater facilities shown or an average of 7.8 dry tons per calendar day. This equates to 10.9 dry tons per day on a five day per week operating schedule. All of the 12 wastewater treatment facilities aerobically digest their sludge using extended aeration or conventional aerobic digestion to generate biosolids. Accordingly, biosolids from all facilities is sufficiently stabilized to be suitable for land application or composting.

Nine of the 12 wastewater treatment facilities dewater their biosolids using either drying beds or belt filter presses. The Town of Manor thickens their biosolids for liquid hauling and also uses drying beds when weather conditions permit. From a total quantity perspective, 91% of the biosolids generated is currently dried or dewatered making it suitable for composting or land application. The balance of liquid biosolids is suitable for land application only unless dewatering is added.

Two entities (Brushy Creek and Manor) reported biosolids generation data for their facilities which was extremely high for their size. Therefore, an average amount of 0.5 dry tons per million gallons (MG) of wastewater treated was used to estimate biosolids production from these facilities based on the average of other plants (see Table 2-2). The biosolids generation data for Cedar Park was also suspected to be high. However, further data analysis is required to verify this. The impact of such an analysis (which is being performed through 1996) will likely yield a lower solids generation rate, which will lower the overall estimated annual biosolids production of all communities by as much as seven percent. For the purpose of discussion and evaluation of costs in this report, the conservative higher generation rate has been used.

Estimated population/generation growth data for nine of the ten entities showed ranges of expected growth of between 150 and 300 percent over the next ten years. Only Anderson Mill expected no growth increase because the land area served is completely built out. From this data, it is not unreasonable to expect a doubling in wastewater flows and, hence, biosolids production

over the next ten years from the current 2,830 dry tons per year to 5,600 dry tons per year or higher.

**TABLE 2-1
ESTIMATED SLUDGE/BIOSOLIDS GENERATION FROM PARTICIPATING COMMUNITIES**

Community/District	Average Wastewater Flow (MGD)	Average Influent BOD	Sludge Treatment Method	Sludge Dewatering Method	Current Method of Disposal	Annual Generation (Dry Tons)	% of Total	Solids Content (%TS)	Reported Cost of Disposal (\$/DT)	10 Year Growth Increase (%)	Yard Waste Data
Anderson Mill MUD	0.919	207	Aerobic Digestion	Gravity Thickened	Haul to Austin WWTP	197	7.0	3	399 ⁵	0	Yes
Brushy Creek MUD	0.379	NA	Aerobic Digestion	Gravity Thickened/ Sand Drying Beds	Landfill and Haul to Austin	69 ¹	2.4	4	319 ⁵	253	No
Cedar Park	1.21	191	Aerobic Digestion	Belt Filter Press	Landfill	420	14.8	20	81 ⁶	233	No
Georgetown	1.4	140	Aerobic Digestion	Sand Drying Bed	Landfill	59	4.8	60	25 ⁶	200	Yes
Georgetown	0.5	150	Extended Aeration	Belt Filter Press	Landfill	75.3		17	88 ⁶	200	
Lakeway MUD	0.485	165	Aerobic Digestion	Belt Filter Press	Landfill	110	3.9	18	255 ⁶	228	No
Leander	0.428	165	Extended Aeration	Sand Drying Beds	Landfill	77.4	2.7	1.5 to 2.1	581 ⁵	150	No
Lost Creek MUD	0.279	183	Aerobic Digestion	Gravity Thickened	Haul to Austin WWTP	35 ⁴	1.3	0.77	2141 ⁵	105	No
Manor	0.076	NA	Aerobic Digestion	Gravity Thickened/ Drying Beds	Haul to Austin and Landfill	14 ¹	0.5	≈ 60	2,633 ⁵	259	No
Pflugerville	1.14	139	Aerobic Digestion	Sand Drying Beds	Landfill	315 ²	11.1	60	21 ⁵	250	No
Round Rock	3.1	166	Aerobic Digestion	Belt Filter Press	Landfill	897 ³	51.5	14	120	138	Yes
Round Rock	3.4	147			Landfill	561 ³					
TOTAL	13.316					2,830 7.75 DT/calendar day 10.88 DT/day - 5 day per week basis					

Notes: Dry tonnage quantities are as reported by communities except as noted below.

¹Estimated using assumed generation of 0.5 dry tons per million gallons sewage treated.

²Calculated based on reported volume generated from drying beds, assumed density of 1,400 lbs/CY and assumed solids content of 60%TS.

³Calculated based on reported wet tonnage generated per week and 14%TS.

⁴Based on 1.092 million gallons at 7,727 mg/l

⁵Calculated value

⁶Reported value NA - not available

Table 2-3 summarizes biosolids chemical characteristics for the 12 wastewater treatment facilities. This data analyzes results obtained from grab samples collected in June 1996. Based on these analyses, the biosolids from all 12 plants meet exceptional (class A) quality standards according to the EPA Part 503 regulations. Further, metals concentration of all the biosolids are below Grade 1 Compost maximum levels with the exception of Brushy Creek's copper level which slightly exceeds the 1,020 mg/kg maximum level by 120 mg/kg. The effect of bulking agent dilution and that of other biosolids would reduce the copper concentration to well below the Grade 1 Compost level after composting. Therefore, based on this limited data, it appears that biosolids from all 12 wastewater plants is suitable for land application or composting.

TABLE 2-2
SLUDGE GENERATION RATES PER MILLION GALLONS SEWAGE TREATED

		Dry Tons	Q (MGD)	DT/MG
Anderson Mill		197	0.919	0.59
Cedar Park		420	1.21	0.95
Georgetown	San Gabriel	59	1.40	0.12
	Dove Springs	75.3	0.50	0.41
Lakeway		110	0.485	0.62
Leander		77.4	0.428	0.50
Round Rock		1458	6.5	0.61
Average ¹				0.54

Notes: ¹An average generation rate of 0.5 DT/MG is assumed for other plants listed in Table 2-1.

**TABLE 2 - 3
JUNE 1996 BIOSOLIDS CHEMICAL CHARACTERISTICS FOR PARTICIPATING ENTITIES**

Travis/Williamson County Biosolids Project

Total Solids	CLASS A	Grade 1 Compost	Lost Cr MUD	Cedar Park		Round Rock West		Round Rock East		Brushy Creek	Manor	G'Town		Dove Springs	Lakeway MUD	Anderson Mill		Pflugerville	Leander
				Grade 1 Compost	Lost Cr MUD	Rock West	Rock East	San Gabriel	G'Town Springs			MUD	MUD						
%	NA	NA	2.21	14.6	14.6	15.1	87.1	57.1	61.2	15.7	16.5	0.49	62.6	17					
Ammonia - N	mg/kg	NA	4810	2590	3940	3690	6690	3480	4740	1420	991	3430	2630	1340					
TKN	mg/kg	NA	55,100	62,200	75,900	63,800	61,700	45,700	27,300	46,000	53,000	67,600	48,200	58,600					
Nitrate	mg/kg	NA	23.0	77.6	24.6	3.51	1.5	1.68	1720	16.3	<3.06	<10.2	2.96	25.5					
Nitrite	mg/kg	NA	<5.0	<5.0	65.9	5.53	1.11	2.01	57.8	3.29	15.3	<10.2	0.88	3.5					
Phosphorus	mg/kg	NA	32,300	32,400	26,900	44,300	28,800	12,400	14,600	22,300	23,100	26,900	20,450	18,620					
Potassium	mg/kg	NA	3100	4970	1750	4180	3690	1400	1220	1680	2920	5730	1800	4200					
Arsenic	mg/kg	41	<8.0	2.4	2.1	2.3	<1.0	<1.0	1.1	2.0	2.7	1.3	<1.0	1.8					
Cadmium	mg/kg	39	3.0	<4.0	10	7	2.0	3	2.0	<4.0	5.0	<4.0	<3.5	<12.0					
Chromium	mg/kg	1200	16.9	9.6	40.3	17.7	10.7	12.0	18.8	17.8	12.7	8.5	20.4	19.4					
Copper	mg/kg	1500	223	245	503	635	1242	482	451	690	394	99.7	841	494					
Lead	mg/kg	300	49	47	88	63	36	47	77	104	75	61	57	75					
Mercury	mg/kg	17	1.1	2.5	2.8	2.3	4.1	9.8	5.3	4.3	5.8	6.1	1.4	2.6					
Molybdenum	mg/kg	Monitor	75	11.9	4.2	34.9	5.2	6.5	5.8	4.3	5.6	3.3	4.5	7.7					
Nickel	mg/kg	420	10.0	14	35	8	14	12	10	<2.0	28	7	14.5	15.3					
Selenium	mg/kg	36	14.4	6.4	4.7	3.9	1.2	2.6	<1.0	5.7	3.3	2.4	1.1	4.8					
Zinc	mg/kg	2800	600	373	544	490	690	670	550	601	1050	230	963	908					
pH		NA	6.22	6.70	7.01	7.19	6.25	6.98	7.18	6.85	6.73	6.27	6.96	6.85					

- Notes: 1. Values based on grab samples collected in June 1996
 2. All concentrations reported in mg/kg on a dry weight basis
 3. Class A ceiling concentrations according to EPA pilot 503
 4. Grade 1 Maximum Allowable Concentrations according to TNRCC Chapter 332

3.0 - REGULATORY REVIEW

Currently two sets of regulations govern biosolids treatment and disposal in Texas: Federal EPA 40 CFR Part 503 and the State of Texas Natural Resources Conservation Commission (TNRCC) Chapter 312 (Sludge Use, Disposal, and Transportation) and Chapter 332 (Composting, Mulching, and Land Application).

3.1 - EPA PART 503 REGULATIONS

The EPA Part 503 regulations apply to all beneficial use options including land application, composting, chemical stabilization and sludge drying. The regulation of all biosolids products which are distributed and marketed are addressed under land application requirements. Three general criteria categories are used to establish sludge quality and the degree to which biosolids must be monitored and how it can be utilized. These include metal constituent concentrations (concentration and ceiling levels), pathogen reduction criteria (Class A and Class B), and vector attraction criteria (processing or barrier induced). If a sludge management strategy meets the highest quality standards set forth in these three general criteria, it will be classified as "exceptional quality" sludge. Monitoring, record keeping, and reporting are required regardless of the biosolids quality. The following sections briefly describe these three general criteria categories as well as monitoring and record keeping requirements under EPA Part 503.

3.1.1 - Metal Constituent Concentrations

Metal constituent limits for land application are listed in Table 3-1.

**TABLE 3-1
EPA BIOSOLIDS POLLUTANT LEVEL LIMITS**

Parameter	Ceiling Limits	EQ Metal Concentration Limits	Cumulative Metal Loading Rate		Annual Metal Loading
	(mg/kg) ¹	(mg/kg) ¹	(kg/ha) ¹	(lb/ac) ¹	(lb/ac/yr) ¹
METALS					
Arsenic	75	41	41	36	1.8
Cadmium	85	39	39	35	1.7
Chromium	3000	1200	3000	2677	134
Copper	4300	1500	1500	1339	67
Lead	840	300	300	268	13
Mercury	57	17	17	15	0.76
Molybdenum	75	monitor	monitor	monitor	monitor
Nickel	420	420	420	375	18.7
Selenium	100	36	100	89	4.5
Zinc	7500	2800	2800	2500	125

¹dry weight basis

To be applied to the land, bulk biosolids must meet the metal ceiling concentrations and cumulative metal loading rate limits. Bulk biosolids applied to lawns and home gardens must meet exceptional quality metal concentration limits. Biosolids sold or given away in bags must meet the metal concentration limits or annual sewage sludge product application rates that are based on the annual metal loading rates. For exceptional quality biosolids, there are no limitations on annual or cumulative loading rates.

3.1.2 - Pathogen Reduction Classification

Biosolids are classified into two categories, Class A and Class B, based upon certain pathogen reduction criteria. Pathogen reduction criteria include maximum concentrations of certain disease indicator organisms (salmonella, fecal coliform, enteric viruses, or helminth ova), and treating biosolids using certain specific methods and documenting the conditions of that method. A minimum of Class B pathogen reduction requirements must be met in order to land apply biosolids. Class A pathogen reduction (as well as metal concentration limits and vector

attraction criteria) requirements must be met in order to distribute and market biosolids products on lawn and home gardens. Land application of Class A biosolids requires compliance with certain minimal management practices. Further site restrictions are required to be met if only class B pathogen reduction requirements are met. Table 3-2 shows the criteria for land application under each pathogen reduction criteria.

TABLE 3-2
PATHOGEN REDUCTION CRITERIA/MANAGEMENT PRACTICES

Pathogen Reduction Criteria	Biosolids Management Practices Required
Class A	<ul style="list-style-type: none"> • Cannot apply biosolids to flooded, frozen or snow covered ground • Apply biosolids at agronomic rates • Maintain ten meter buffer from limit of application to surface water • Cannot apply in areas where threatened or endangered species would be adversely affected
Class B	<p>In addition to Class A requirements, the following criteria apply:</p> <ul style="list-style-type: none"> • Food crops with harvested parts that touch the biosolids/soil mixture (such as melons, squash, cucumbers, etc.) shall not be harvested for 14 months after application • Food crops with harvested parts below the soil surface (root crops such as potatoes, carrots, radishes) shall not be harvested for 20 months after application if the biosolids is not incorporated for at least four months. • Food crops with harvested parts below the soil surface (root crops such as potatoes, carrots, radishes) shall not be harvested for 38 months after application if the biosolids is incorporated in at less than four months. • Food crops, feed crops, and fiber crops shall not be harvested for 30 days after biosolids application. • Animals shall not be grazed on a site for 30 days after biosolids application. • Turf shall not be harvested for one year after biosolids application if the turf is placed on land with a high potential for public exposure of a lawn. • Public access to land with high potential for public exposure shall be restricted for 1 year after biosolids application. • Public access to land with low potential for public exposure shall be restricted for 30 days after biosolids application.

Table 3-3 shows a summary of the pathogen reduction alternatives outlined in the 503 rule. For pathogen reduction Alternative 1, a range of times and temperatures are allowed. The

temperature/times range from 50°C for 15 hours to 70°C for 15 minutes. Alternative 5 calls for maintenance of 55°C or greater for three consecutive days.

**TABLE 3-3
PATHOGEN REDUCTION ALTERNATIVES FOR CLASS A COMPOST**

<p style="margin: 0;">All Alternatives:</p> <ul style="list-style-type: none"> • Fecal coliform < 1000 MPN / gm Total Solids <i>OR</i> • Salmonella < 3 MPN / 4 gms Total Solids
<p style="margin: 0;">Alternative 1</p> <ul style="list-style-type: none"> • Temperature / Time mathematical relationship
<p style="margin: 0;">Alternative 2</p> <ul style="list-style-type: none"> • pH > 12 for > 72 hours and • Temp. > 52°C for 12 hours • After 12 hours > 50% solids reduction
<p style="margin: 0;">Alternative 3</p> <ul style="list-style-type: none"> • Virus < 1 PFU / 4 gms Total Solids • Helminth Ova < 1 viable ova / 4 gms Total Solids <p style="margin: 0;">- untreated (sample by sample)</p> <p style="margin: 0;">- Pathogen treatment process (operating parameters)</p>
<p style="margin: 0;">Alternative 4</p> <ul style="list-style-type: none"> • Virus < 1 PFU / 4 gms Total Solids • Helminth Ova < 1 viable ova / 4 gms Total Solids
<p style="margin: 0;">Alternative 5</p> <ul style="list-style-type: none"> • PFRP Temperatures > 55°C for three consecutive days
<p style="margin: 0;">Alternative 6</p> <ul style="list-style-type: none"> • PFRP equivalent

3.1.3 - Vector Attraction Criteria

Vector attraction reduction reduces potential for spreading of infectious diseases by vectors (flies, mosquitoes, rodents, and birds). There are 12 different vector attraction criteria in Part 503 of which at least one must be met to land apply sewage sludge. Table 3-4 summarizes these options. These criteria include processing options such as digestion as well as physical barrier options, including injection and incorporation of biosolids into the soil.

TABLE 3-4
SUMMARY OF OPTIONS FOR MEETING VECTOR ATTRACTION REDUCTION

<i>Option 1:</i>	Meet 38% reduction in volatile solids content.
<i>Option 2:</i>	Demonstrate vector attraction reduction with additional anaerobic digestion in a bench-scale unit.
<i>Option 3:</i>	Demonstrate vector attraction reduction with additional aerobic digestion in a bench-scale unit.
<i>Option 4:</i>	Meet a specific oxygen uptake rate for aerobically digested biosolids.
<i>Option 5:</i>	Use aerobic processes at greater than 40°C for 14 days or longer.
<i>Option 6:</i>	Alkali addition under specified conditions.
<i>Option 7:</i>	Dry biosolids with no unstabilized solids to at least 75% solids.
<i>Option 8:</i>	Dry biosolids with unstabilized solids to at least 90% solids.
<i>Option 9:</i>	Inject biosolids beneath the soil surface.
<i>Option 10:</i>	Incorporate biosolids into the soil within 6 hours of application to or placement on the land.
<i>Option 11:</i>	Cover biosolids placed on a surface disposal site with soil or other material at the end of each operating day. (NOTE: only for surface disposal).
<i>Option 12:</i>	Alkaline treatment of domestic septage to a pH of 12 or above for 30 minutes without adding more alkaline material.

3.1.4 - Monitoring, Record Keeping, and Reporting Requirements

The frequency of monitoring for metal constituents, pathogen densities, and vector attraction reduction requirements is based on the quantity of biosolids generated on an annual basis as shown in Table 3-5. Record keeping requirements vary according to the end use of the biosolids material and must be maintained for 5 years. Table 3-6 describes examples of records required.

TABLE 3-5
MONITORING FREQUENCY

Biosolids (dry tons per 365 day period)	Monitoring Frequency
> 0 to < 320	once per year
320 to < 1,650	once per quarter
1,650 to < 16,500	once per 60 days (6 times per year)
> 16,500	once per month (12 times per year)

TABLE 3-6
LAND APPLICATION RECORD KEEPING REQUIREMENTS

Biosolids Quality/Use	Records Required
Exceptional Quality	Metals constituent records, description of Class A pathogen reduction and vector attraction reduction
Land application w/physical barriers for vector attraction reduction	Certification that vector attraction reduction rules are followed
Class B pathogen reduction and below metal constituent limit	Certification that these criteria and site restrictions have been met
Land application of sludge with metal constituent above concentration limits	Certification of pathogen and vector attraction requirements and records on application date, site location, site size, and cumulative loading rates
Class A pathogen criteria above metal concentration limits and sold or given away	Certification of pathogen and vector reduction criteria used, annual application rate and record of annual metal loading rate

3.2 - TNRCC CHAPTER 312 REGULATIONS FOR SLUDGE USE, DISPOSAL, AND TRANSPORT

If a biosolids to be reused meets Class A pathogen reduction requirements, vector attraction reduction requirements, and metal concentration limits, a permit is not required. At least 30 days prior to engaging in reuse activities, a notification form must be submitted to the permitting section of the Watershed Management Division of the TNRCC. The notification shall contain:

- Sewage sludge composition, all points of generation, and wastewater treatment facility identification
- Name, address, and telephone number of all persons receiving sludge
- Description of marketing and distribution plans

Thirty days after the notification has occurred, activities may commence. Annually, on September 1, each person subject to notification of certain Class A activities must provide a report to the commission, on forms furnished by the commission, which describes all of the above mentioned activities. The report must include an update of new information since prior reporting and a description of annual amounts of sewage sludge reused.

The following information will need to be included in a TNRCC permit application for a biosolids reuse project for materials not meeting the requirements listed above. The list below is an abbreviated description, and the full requirements can be found in Section 312.11 of the TNRCC Sludge Use document.

- An original and several copies, as specified by the permit authority
- Site map depicting the approximate boundaries of the tract of land owned and all residents and businesses within 1/2 mile of the site
- Operator name, address, telephone number
- Determination of whether the facility is located on Native American lands
- Legal owners of the land
- Description of the biosolids
- Description of all processes generating the biosolids
- Detailed description of the beneficial use occurring at the site
- Information describing soil characteristics and subsurface conditions
- Analytical results for metals regulated by this document for the soil and biosolids
- Analytical results for nutrients, salinity, soil pH for the biosolids and the soil

The TNRCC sludge reuse regulations do not apply to sludge containing 50 ppm or greater of PCB's. Additional and more stringent regulations may be imposed at the discretion of the TNRCC on a case by case basis. Reporting requirements include notification of when a site reaches 90% of its cumulative loading limit and reporting of any application which occurs after this point has been reached.

Fees due to the TNRCC for the reuse of biosolids are as follows. A minimum of \$100 is due annually, regardless of whether the site is active or in-active. For Class A biosolids, \$0.20 per dry ton fee will be collected. For Class B, \$0.75 per dry ton will be collected. In addition, an annual transportation fee will be required as follows in Table 3-7.

**TABLE 3-7
ANNUAL TRANSPORTATION FEE**

Gallons	Fee
less than or equal to 10,000	\$100
10,000 - 50,000	\$250
50,000 - 200,000	\$400
greater than 200,000	\$500

In addition to monitoring requirements for the biosolids, soil will need to be monitored at the application sites for metals and nutrients. All of the metals listed above must be monitored in the soil. Nutrients, salinity, and pH in the top six feet as well as in the 6 to 24 foot zone must be monitored as well. One composite sample must be taken for every 80 acres of land at an application site.

For class B material, there are ground and surface water restrictions which must be met. For slow permeable soils, the seasonal high water mark must be three feet below the application zone. For rapid permeable soils, a four foot buffer is required. Other buffers for Class B materials include:

- Not incorporated within 48 hours - to surface water 200 feet
- Incorporated within 48 hours - to surface water 33 feet
- Private water supply well 150 feet
- Public water supply well 500 feet
- Solution channel, sinkhole, or conduit to groundwater 200 feet
- School, institution, business, or occupied residential structure 750 feet
- Public right of way 50 feet
- Irrigation conveyance canal 10 feet
- Property boundary 50 feet

Several site restrictions apply to Class B materials as well. These include:

- Harvesting of food crops above ground - 14 months after application
- Food crops below ground - 20 months when incorporated after 4 months on the ground
- Food crops below ground - 38 months when incorporated before the materials have been on the ground for four months
- Food, feed, fiber - 30 days
- Grazing - 30 days
- Turf grass - 1 year
- Public access with high potential for exposure - 1 year
- Public access with low possibility for exposure - 30 days

3.2.1 - Public Notice for Land Application Projects

Notice is required only if Class B materials are applied. Notice is not required if Class A biosolids are applied. If applying Class B materials, the chief clerk of the commission will mail a notice of receipt of application and declaration of administrative completeness, along with a copy of the registration application, to the county judge in the county where the proposed site for land application of biosolids is located. The chief clerk of the commission will also mail these items to the landowners named on the application map or in the application. Each notice will specify

both the name, affiliation, address, and telephone number of the applicant and of the commission employee who may be reached to obtain more information about the application to register the site. The notices shall specify that the registration has been provided to the county judge and that it is available for review.

A person may provide the commission with written comments on any new or major amendment applications to register a site for land application of sewage sludge. The executive director shall review any written comments when they are received within 30 days of the notice. The written information will be utilized by the executive director in determining what action to take on the application for registration.

3.3 - TNRCC CHAPTER 332 REGULATIONS FOR BIOSOLIDS COMPOSTING

The TNRCC has adopted a tiered regulatory approach which considers the size of an operation and the type of materials being composted. This approach is used to determine which regulations apply and what level of permitting is required. Facilities which compost septage tank waste or sewage sludge (biosolids) with bulking agents other than yard trimmings or clean wood material are classified as compost facility type CA, and require the owner or operator to submit an application prepared in accordance to Section 332.60(c)(1) of the TNRCC Composting, Mulching, and Land Application document. The document listed above states that no composting or mulching activities shall be conducted on the cap of a landfill without prior approval by the commission on a case-by-case basis. A permit application can be obtained from and when completed should be submitted to the TNRCC at the following address:

TNRCC Municipal Solid Waste Division
P.O. Box 13807
Austin, TX 78711-13087
(512) 239-6717

Biosolids composting projects which use only yard trimmings and clean wood materials will require registration and are subject to the general requirements, operating requirements, and end-product requirements of the TNRCC Chapter 332 document. This scenario is that which is assumed to apply for the purposes of composting facilities evaluated for LCRA as part of this report. The provisions of this document are described below.

General requirements include compliance with the Texas Water Code designed to prevent pollution of the surface or ground water. Operations must be conducted in accordance with Federal and State regulations. If operations are conducted at a solid waste facility or a wastewater treatment facility, permit amendments must be obtained.

An air permit must be obtained under the authority of the Texas Clean Air Act. All roads must be treated, watered, paved and/or cleaned in order to achieve dust control. Prior to obtaining quantities of potentially odorous feedstocks, adequate bulking agent must be on site for proper mixing. When materials are pneumatically conveyed, air must be vented to the atmosphere through a fabric filter having a maximum filter velocity of four feet per minute. Grinders and conveyors must use sprayer systems for dust control.

Operational requirements for registered facilities include the following:

- Certification by a registered engineer (State of Texas Registration)
- Ownership or control of property by operator
- Inspection of facility prior to acceptance of any new feedstock type

Registration applications for composting must include:

- Title page
- Signature of applicant
- Affidavit verifying land ownership and landowner agreement of proposed activity
- Table of contents
- Legal authority
- Evidence of competency
- Notice of Appointment
- Notice of Coordination
- Legal description
- Location description
- Landowner list
- Site operating plan
- Process description
 - feedstock identification
 - tipping process, process, post process
 - production distribution
 - process diagram
- Personnel
- Security

Location standards for facilities include:

- Outside of 100 year flood plain, unless applicant can demonstrate that washout will not occur
- Shall not significantly alter existing drainage plans
- Shall be located at least 500 feet from all public water wells and at least 150 feet from private water wells
- Shall be at least 100 feet from creeks, rivers, intermittent streams, lakes, bayous, bays, estuaries, or other surface waters in the state
- Subject to Chapter 313 if located above the Edwards Aquifer Recharge Zone

Operational standards include:

- Collect and manage the 25 year 24 hour storm water flow
- Liners must be employed consisting of soil, synthetic material, or alternative that is equivalent to two feet of compacted clay with a hydraulic conductivity of 1×10^{-7} centimeters per second or less
- Preclude the entry of any prohibited materials
- Control access to site
- Prevent nuisance and fire hazard
- Aerobic composting must be achieved
- A site sign must be in place
- Access road must be an all weather road
- End product standards must be met
- A TNRCC certified compost operator must be employed within six months of beginning operations (once the certification program is available).

TNRCC defines compost grades as Grade 1, Grade 2, and Waste Grade compost. These are defined by the level of treatment, pollutants, and maturity of the compost. Foreign matter, maturity, metals content, pathogen reduction, salinity, and pH are all used to define the grade of a finished compost.

Grade 1 compost (no restriction on end use):

- Shall contain no foreign matter of a size or shape that can cause harm to a human or animal
- Shall not exceed maximum allowable concentrations for Grade 1 compost as described in Figure 1
- No foreign matter greater than 1.5% dry weight on a 4mm screen
- Meet cured compost requirement of Figure 2
- Meet pathogen reduction requirements of Figure 3
- Meet salinity and pH requirements as described in Figure 3

Grade 2 compost (shall not be used at a residence or licensed child care facility):

- Shall contain no foreign matter of a size or shape that can cause harm to a human or animal
- Shall not exceed maximum allowable concentrations for Grade 2 compost as described in Figure 1
- No foreign matter greater than 1.5% dry weight on a 4mm screen
- Meet semi-mature, mature, or cured compost requirement of Figure 2
- Meet pathogen reduction requirements of Figure 3
- Meet salinity and pH requirements as described in Figure 3

Waste Grade compost:

- Exceed maximum allowable concentrations for Grade 2 compost
- Does not meet any of the other requirements of Grade 1 or Grade 2 compost

Labeling requirements include:

- Grade of compost
- Feedstock description
- Soil incorporation guidelines (mix into 15 inches of soil)

FIGURE 1: 30 TAC 332.72

TABLE 1
MAXIMUM ALLOWABLE CONCENTRATIONS
(mg/kg on a dry weight basis)

Parameter	Grade 1 Compost (mg/kg)	Grade 2 Compost (mg/kg)
As	10	41
Cd	16	39
Cr (total)	180	1,200
Cu	1,020	1,500
Pb	300	300
Hg	11	17
Mo	75	75
Ni	160	420
Se	36	36
Zn	2,190	2,800
PCBs	1	10

FIGURE 2: 30 TAC 332.72

**TABLE 2
MATURITY AND STABILITY STANDARDS**

Method	Semi-Mature Compost	Mature Compost	Cured Compost
Reduction of Organic Matter (ROM) (%)	Between 20% and 40%	Between 40% and 60%	Greater than 60%
Other Methods	Maturity Protocol	Maturity Protocol	Maturity Protocol

FIGURE 3: 30 TAC 332.72

**TABLE 3
ADDITIONAL FINAL PRODUCT STANDARDS**

Parameter	Grade 1 Compost	Grade 2 Compost
Salinity ¹ (mmhos/cm)	10	10
pH	5.0 to 8.5	5.0 to 8.5
Pathogens:		
Fecal Coliform	Less than 1,000 MPN per gram of solids or meets PFRP	Geometric mean density less than 2,000,000 MPN per gram of solids or meets PSRP
Salmonella	Less than 3 MPN per 4 grams total solids or meets PFRP	No value

Note: 1 A higher conductivity of pH outside the indicated range may be appropriate if the compost is specified for a special use.

3.3.1 - Composting Facility Public Notice Requirements

When the application is complete, the chief clerk will mail notice to the identified adjacent landowners. The chief clerk will also mail notice to the other affected landowners as directed by

the executive director. The applicant will publish notice in the county in which the facility is located, and in adjacent counties. The published notice should be published once a week for three weeks, and an effort must be made to put the notice in the Sunday paper. The notice must explain the method for submitting a motion for reconsideration. The notice must contain the following information:

- the identifying number given the application by the executive director
- the type of registration sought under the application
- the name and address of the applicant
- the date on which the application was submitted
- a brief summary of the information included in the application

The executive director will, after review of any application for registration of a compost facility determine if he will approve or deny an application in whole or in part. The executive director will base his decision on whether the application meets the requirements. At the time that the decision is mailed to the applicant, copies will be sent to the adjacent landowners, residents, and businesses.

A decision by the executive director, including a registration issued by the executive director, is not affected by the filing of a motion for reconsideration under this section unless expressly so ordered by the commissioners. If a motion for reconsideration is not acted on by the commissioners within 45 days after the date on which the chief clerk mailed the signed registration to the applicant, the motion will be deemed overruled.

4.0 - TECHNOLOGY ASSESSMENT

This chapter provides an overview of beneficial use options which are being considered for biosolids management by LCRA. A variety of municipal biosolids management alternatives are available today which have been successfully demonstrated. Only the beneficial use options of land application and composting are the specific processes being considered in this study. These processes include the following:

Land Application:

- Liquid biosolids subsurface injection
- Surface application of dewatered biosolids
- Surface application and incorporation of dewatered biosolids

Composting:

- Aerated static pile
- Aerated turned windrow
- Un-aerated turned windrow
- Aerated agitated bed

This chapter provides an overview of the technologies being considered as well as an assessment of the existing practices of these technologies throughout the United States. It finishes with the comparison of land application and composting technologies.

4.1 - OVERVIEW OF LAND APPLICATION TECHNOLOGIES

Land application of stabilized biosolids is widely practiced in the United States. Stabilization prior to land application is required to reduce pathogenic organisms present in the biosolids. The beneficial use of biosolids products is based on utilizing the macronutrients of nitrogen, phosphorus, and potassium and certain levels of trace elements (such as copper, selenium, and boron) to benefit the growth of plants, including grasses, agricultural crops, and trees.

Biosolids from the facilities can be considered a low grade fertilizer, and application rates can be calculate based upon the agronomic needs of the target crop. The nitrogen level in the biosolids will likely be the limiting factor, so the loading rates are given in dry pounds nitrogen

per acre. The application method will affect the rate of plant available nitrogen due to different levels of loss to the atmosphere. For instant, if a material is surface applied and tilled in three days later, there will be much higher loss of ammonia nitrogen to the atmosphere than if the biosolids are subsurface injected. Assuming that the biosolids meet the 503 EQ level requirements, the material can be applied agronomically.

The quantity of biosolids that can be applied to land must be calculated for each specific site, soil, and crop to meet the current and future guidelines for metal addition and to ensure no over application of nitrogen to the soil. Where there is no path to the food chain, (landscaping, forest, site reclamation), heavier application rates may be considered.

Biosolids are applied to land either as a liquid, thickened, or dewatered material. Liquid biosolids are commonly applied by surface or injection techniques. Truck mounted spray equipment and spray irrigation systems are suitable for surface applications. Specially designed biosolids application vehicles are used for subsurface injection. Dewatered biosolids can be surface applied and incorporated into the soil with conventional tilling equipment.

Liquid or thickened biosolids transported to the agricultural application site using a tanker truck. Dewatered biosolids are hauled in a sealed or trailer truck. Liquid/thickened material can be applied using:

- a spray bar fitted behind a towed or self powered tanker
- a spray irrigation nozzle mounted on a towed or self powered tanker
- spray irrigation nozzle, ground mounted, powered or pulled by cable
- a direct injection system, fitted to plow tines mounted behind a tanker vehicle
- a direct injection system, fitted to plow tines on a tractor attached to a long hose fed from a stationary tank

Where the biosolids product is applied to the ground surface, it can be left on the surface, eventually combining with the surface humus and litter layer (i.e. in the forest), or plowed or disced in and blended with the surface soil layers. Table 4-1 shows the advantages and disadvantages of agricultural land application.

TABLE 4-1
ADVANTAGES AND DISADVANTAGES OF LAND APPLICATION

ADVANTAGES	DISADVANTAGES
<ul style="list-style-type: none"> • Potential for the development of additional capacity with minimal cost • Low cost alternative • Potential for use on multiple crop types • No biosolids dewatering necessary 	<ul style="list-style-type: none"> • Many potential agricultural uses are governed by seasonal demands, particularly in the farming sector • Spring and possibly autumn are high demand months • Storage capacity is required at the wastewater treatment plant to store thickened biosolids • Additional sites require additional permitting • Significant acreage of land is required to manage biosolids • Cannot be utilized during rainy weather

4.2 - LAND APPLICATION TECHNOLOGIES ASSESSMENT

This section of the report summarizes key factors involved in the design and operation of land application programs. Information that was gathered through the use of telephone surveys, site visits, and literature review is described in the following sub-sections.

4.2.1 - Area Requirements

The application rates and therefore the land requirements are dependent upon the application method, the site conditions, the biosolids nitrogen content, and the crops grown. Agricultural crop nutrient uptake rates have a wide range. Table 4-2 shows some examples of nitrogen uptake rates for a few specific crops.

TABLE 4-2
NITROGEN UPTAKE OF AGRICULTURAL CROPS

Crop	Nitrogen Uptake (dry lb/acre)
corn	240
corn silage	200
wheat	125
oats	150
alfalfa hay	330

Table 4-3 shows the estimated ammonia nitrogen retained after biosolids application for several different materials and application methods. This will help determine the available plant nitrogen in the biosolids over time.

TABLE 4-3
ESTIMATES OF AMMONIA NITROGEN RETAINED AFTER APPLICATION

Days to Incorporation by Tillage	Surface Applied				Injected Biosolids	Compost or Drying Bed Biosolids
	Liquid Biosolids, pH >7	Dewatered Biosolids, pH >7	Liquid or Dewatered pH <7	Lime Stabilized Biosolids		
	<i>Ammonia and Ammonium - Nitrogen Retained, Percent of Applied</i>					
0 to 2	80	60	90	10	100	100
3 to 6	70	50	90	10	100	100
over 6	60	40	90	10	100	100

Mineralization rates for biosolids range from 10 to 35%, but usually are in the range of 20% for the first year following application. For the purposes of this discussion, 20% will be used. Mineralization is the rate at which organic nitrogen is converted to plant available nitrogen. The example below shows the calculations necessary to estimate an agronomic loading rate of biosolids assuming the nitrogen contents as shown.

What follows is a brief summary of agronomic loading rate calculations and an estimate for acreage needed to apply biosolids. Typically, if land application is chosen as a reuse method, additional information is gathered concerning application site background information, application method, crop rotations, fertilizing practices, and more. This estimate assumes that the crop grown needs 200 pounds per acre of nitrogen and the incorporation method is subsurface injection, which means no nitrogen losses to the atmosphere. This is, therefore, a fairly conservative estimate relative to land area requirement.

Inorganic Nitrogen Content	0.3%
Pounds of Inorganic Nitrogen/Dry Ton	6
Organic Nitrogen Content	5.6%
Pounds Organic Nitrogen/Dry Ton	112
Mineralization Rate	20%
Pounds Inorganic Nitrogen/Dry Ton	22.4
Pounds Available	22.4
Total Plant Available Nitrogen	28.4

Biosolids needed to satisfy agronomic needs: $200 \text{ lb/acre} \div 28.4 \text{ lb/dry ton} = 7.0 \text{ dry tons/acre}$

Table 4-4 describes the acreage needed for different solids content biosolids. The Table shows the difference between materials at 8, 15, 20, and 25% solids.

TABLE 4-4
SUMMARY OF BIOSOLIDS
LAND APPLICATION QUANTITIES PER ACRE

Percent Solids	Dry Tons per Acre	Wet Tons per Acre	Gallons per Acre
8%	7	88	21,000
15%	7	47	11,000
20%	7	35	8,200
25%	7	28	6,600

Once the acreage necessary is identified, additional site specific buffers are added to keep application away from surface waters, wells, other properties, etc. to determine land area for a given quantity of biosolids.

4.2.2 - Site and Utility Requirements

Typically, no site utilities are needed for land application programs. Site selection criteria are in line with agricultural practices. These criteria include looking for a site with little or no surface water in the vicinity. To avoid perceived or actual problems with surface water quality degradation, for example, the application of biosolids cannot occur within ten meters of U.S. surface waters, including tidal waters. In addition, the application of biosolids to an area cannot have an adverse effect on the likelihood of survival and recovery of an endangered or threatened species. Critical habitat includes any place where such a species lives and grows during its life cycle. Application to frozen or snow covered land is not prohibited, but controls must prevent runoff to surface areas. Common runoff controls include buffers, tillage, vegetative strips, berms, dikes, silt fences, etc.

4.2.3 - Capital and Operating Costs

Equipment requirements for land application of biosolids include manure spreaders or subsurface injection tanker/trucks, a soil tiller, and a tractor to pull the equipment. Materials are usually tilled within a short period of time (usually 24 hours). Dewatered biosolids are typically surface applied with a manure spreader type technology, while liquid biosolids (up to 8% solids) are often injected into the soil. This practice helps maintain a clean operation and reduces the volatilization of ammonia nitrogen while biosolids sit on the surface of the soil. The application of dewatered biosolids will require tilling into the soil within 24 hours of arrival at the site. These pieces of equipment can be truck or trailer mounted. Trailer mounted units are pulled by tractors or field trucks with hydraulic or PTO drive connections.

As reported by several contractors who land apply biosolids, operating and maintenance costs can range from \$20 to \$30/dry ton applied depending on site conditions and services rendered. These figures should be used for comparison only as no one contacted would commit to an exact figure for this expenditure. Additional operating and maintenance costs include fuel (approximately 20 gallons per hour), monitoring and lab analysis, salary overhead, and maintenance of equipment (5% of capital costs annually).

4.2.4 - Environmental Controls

In order to ensure control of potential environmental problems, the operations must occur within the designated application area, avoiding all defined buffer zones. In addition, if dewatered biosolids are applied, the material needs to be incorporated into the soil within 24 hours. This will help prevent vector attraction, odors, and volatilization of ammonia nitrogen. Also, strict adherence to the agronomic loading rate, which is designed to apply nutrients at a rate no higher than the uptake rate of the crop grown, will prevent degradation of surface and ground water.

4.2.5 - Staffing

Typically, one operator and applicator is required for each 200 wet tons of material applied per day. This operator can also operate the tiller with the same tractor. The time of a water/wastewater operations manager and an operations and maintenance coordinator will also be

required. Depending on the project size, these can range from 5% - 20% of the individual's time for coordination.

4.2.6 - Summary of Comparable Biosolids Land Application Programs

The following Table 4-5 summarizes data from a variety of existing land application facilities across the country. These operations represent various sizes and technologies, and the data shows the costs associated with the operations.

**TABLE 4-5
LAND APPLICATION FACILITIES**

Name/Location	BioGro Kern and Riverside Co., CA	Environmental Protection and Improvement Company	Ag-Tech Yuma, Arizona	MERCO	McCarthy Farms/Black & Veatch Kings County, CA
Primary Clients	City of Los Angeles Board of Public Works	Bergen County, New Jersey	LA County, Orange County, City of Escondido, City of Yuma	New York City, NY	LA County Sanitation District
Contact	Brian True	James Lauria (201) 807-8689	Kenny Evans (602) 726-3033	Mike Quinn (718) 595-5043	Jon Hay (714) 753-0500
Size	50 - 100 DT/day	150 DT/day lime stabilized material	120 DT/day	50 DT/day (designed for 125DT)	250 DT/day
O&M Costs	\$20 - 33/DT	N/A	\$29/DT	N/A	Estimate quantity, cost, \$20-30/DT
% Solids Sludge	24%	50%	20-24%	28%	26%
Contract Fee (\$/DT)	\$108-166/DT	\$82/DT	\$120-160/DT	N/A	\$30/DT (haul and apply)
Gross Annual Income (\$/yr)	\$2.8-4.4 million	\$4.5 million	\$5.3 - 7.0 million	\$12.4 million	\$2.7 million
Operator	BioGro	Environmental Protection and Improvement Company	Ag-Tech	MERCO	Black & Veatch
System	Land application	Land Application in NY, NH; landfill cover in PA	Land application, subsurface injection	Land application, Range land	Land application
Sludge Class	Class A	Class A	Class A	Class B	Class B
Disposal Arrangements	Other contracts available	Contractor required to take 100%	Other contracts available	N/A	Landfill, Alternative reuse option
Contract Start Date	1989	1995	1988	June 1992	1994
Contract Term	3 years with 2-3 year extension options	5 years with EPIC; contracted with BioGro for 2000-2010.	3 years with 2-3 year extension options	6 years with 5 year renewal option	2 - 3 years
Comments	Dicing and subsurface injection	Contractor required to have beneficial reuse options in 4 states.	Subsurface injections at 8% solids		

NA - Not Available

4.3 - OVERVIEW OF COMPOSTING TECHNOLOGIES

Composting is a biological conversion process where the organic constituents of wastes are rapidly decomposed under controlled aerobic conditions. Controlled conditions allow for elevation and subsequent decrease in temperature as a result of the growth of thermophilic microbes in the compost pile with subsequent die-off of organisms and pathogen kill. The process results in a highly stable product suitable for use as a soil amendment in horticultural and agricultural practices and can be suitable for distribution to the public, landscapers, and other horticultural and nursery users. A variety of composting technologies are available today which can convert dewatered sludge or biosolids to a stable soil-like conditioner that is suitable for land application. These technologies can be classified under three general categories:

- Windrow
- Aerated static pile
- In-vessel

The common elements, as well as the differences, of each of these systems are discussed in the following sections.

4.3.1 - Process Overview

Composting uses micro-organisms to decompose volatile organic matter into a stabilized organic residue with a release of carbon dioxide and water. Energy (heat) generated due to the decomposition of solids promotes the evaporation of water and kills pathogens in the biosolids. Energy production depends on a number of factors like pH, carbon to nitrogen ratio of the mixture, type of biosolids processed (aerobic or anaerobic), and the type of mixture of bulking agent. The following key parameters are important for successful composting:

- Aeration
- Moisture content
- Carbon to nitrogen ratio

Depending on the characteristics of the feed substrate, temperatures during the composting process can reach such high levels that biological activity may actually be impeded. As a result, air circulation is not only essential to meet oxygen demands, but also to remove heat, water, and moisture produced due to biological activity. The required oxygen concentration of 5 to 20

percent throughout the pile can be met by several different methods. In aerated static piles, air is drawn or pushed through the pile using low pressure, high volume blowers, and an immersed piping system. In windrow systems, the piles are periodically turned or agitated to expose new surfaces and renew the entrained air supply. Proprietary in-vessel systems use either one or both of these concepts in their process.

In order to facilitate the movement of air through the composting mass, the dewatered biosolids are mixed with a bulking agent prior to aeration. A bulking agent is an organic or inorganic material of suitable size to provide structural support and maintain air space when added to the wet biosolids. It also absorbs moisture and can provide an energy source for the microorganisms. The biosolids bulking agent mix should have a porosity of at least 40 percent to avoid the formation of biosolids balls. Air circulation also minimizes odor problems associated with anaerobic composting. A second important parameter is the moisture level in the pile. Moisture levels below 40 percent restrict microbial activity. If the moisture level exceeds 60 percent, the porosity in the pile is decreased and the required oxygen cannot reach the center of the pile. This condition not only reduces the rate of decomposition, it also leads to the formation of odor forming compounds in the center of the pile. The quality of finished compost is also affected. The sources of moisture include the incoming sludge, bulking agent, and inclement weather (if outdoors). Moisture in the final product should be no more than 40 to 50 percent to successfully market the product.

A third requirement is the carbon to nitrogen ratio of the mixture undergoing composting. The desirable carbon to nitrogen ratio ranges from 25 to 30 units of carbon for every unit of nitrogen. Carbon values in excess of 30 tend to slow the process and decrease temperatures. With low carbon to nitrogen ratios, excessive ammonia may be released and the nitrogen content of the compost is reduced.

Temperature also plays an important role in producing a stabilized, acceptable product. Optimum temperatures of about 50°C result in accelerated stabilization and removal of moisture with minimal odor production. Optimum temperatures must be higher to kill pathogens and meet U.S. EPA time/temperature requirements for a process to further reduce pathogens. Higher

temperatures (greater than 60°C) can produce a wet and not well stabilized compost due to decrease in the population of aerobic microorganisms.

4.3.2 - Bulking Agents

Also known as amendments, bulking agents are organic or inorganic materials added to biosolids to condition them for composting. All three types of composting systems previously mentioned require a bulking agent to manage biosolids. Selection of bulking agents is important to the performance and cost of composting systems. Bulking agents meet the following needs of composting systems:

- Adjust the moisture content
- Provide porosity for air circulation
- Add carbon to adjust the carbon to nitrogen ratio
- Provide supplemental organic content
- Dilute heavy metal content of biosolids

To be suitable as a bulking agent the material should be relatively dry (more than 55 percent solids), uniform in particle size (0.75 to 2.0 inches, depending on the type of system) and free of inclusions, such as metal and plastic. Properties of the biosolids determine the type and suitability of a bulking agent. A wide variety of materials may be considered when selecting a bulking agent. The following materials are commonly used or have been tested in biosolids composting facilities in the United States.

- Wood chips suitable for pulp mills
- Sawdust
- Whole tree chips
- Ground-up recycled lumber
- Leaves and brush
- Straw
- Shredded rubber tires
- Shredded paper
- Rice hulls

Bulking agent selection depends on year-round availability of a uniform material. This uniformity applies to moisture content, as well as product texture. Yard wastes may require shredding to facilitate the feeding and mixing operations. Agricultural wastes may be available on a seasonal basis only. To insure an adequate supply of seasonal type bulking agents for a

year-round operation, a storage facility must be provided. Small particle bulking agents, such as sawdust, peanut hulls, straw, peat, and rice hulls will be difficult to screen-out of the final product. This will require new material for each cycle, whereas shredded tires or wood chips can be screened out and reused. If the bulking agent is not screened out, the volume of compost produced per dry ton of biosolids may be two to three times greater than with screening, which is a very important consideration. The compost will also be more dilute with respect to both nutrients and contaminants if not screened. Bulking agent selection is, therefore, influenced by the market for the compost.

Finally, the cost varies greatly for bulking agents. Wood chips are in wide demand as a fuel, mulch, and feedstock for papermills and the composting facility must, therefore, pay competitive market prices. Materials such as yard wastes may be available at little cost. Some composting facilities charge a disposal fee to landscape contractors wishing to dispose of such wastes. Processing yard wastes by grinding becomes a necessary step in the overall process where this is practiced. Transportation costs will also contribute to the final price of bulking agents, since the source of sawdust and wood chips may be remote from the point of use.

4.3.3 - Composting Systems

Three general types of composting systems are utilized for biosolids composting. Windrow composting takes place when the biosolids/bulking agent mixture is deposited in long, four to six-foot deep rows which are periodically turned over by mechanical turning equipment to expose the mixture to ambient oxygen. Windrow systems, by nature, operate at an oxygen deficit within the pile in between pile turnings, especially in the first one to two weeks of the process when biological activity is the greatest. This situation can slow the composting process slightly. It also creates a greater potential for malodor generation and release during turning events as compared to the other systems. Static pile systems utilize deeper (six to 12 feet) piles to compost the mixture of biosolids and bulking agent. These piles are aerated by forced ventilation systems installed under the piles. This aeration system maintains the necessary oxygen level and controls temperature throughout the pile. In-vessel systems carry out the composting operation in environmentally controlled vessels or bins. In-vessel systems may be

classified by material flow direction as vertical or horizontal. Further classification separates static or plug flow types from the agitated bed systems. The enclosed nature of in-vessel systems can have better public and operator acceptance due to aesthetics and the potential for better odor control. Recent trends to enclose aerated static pile facilities can accomplish the same objective.

A generalized flow diagram of a composting process is shown in Figure 4-1. Dewatered biosolids are mixed with a bulking agent. The mixture is aerated for 15 to 28 days by periodic turning, forced aeration, or a combination of both. Residence time for this composting stage varies with the type of biosolids mixture and regulatory requirements. Bulking agent recovered by screening or finished compost may be recycled. Compost cannot be screened if the moisture content exceeds 45 to 50 percent. Some composting facilities include a drying stage ahead of screening. Screening also helps produce a finely graded product which is more marketable than the compost mixed with wood chips. The compost is cured for an additional 30 days by making piles eight to ten feet high. In some systems, air is introduced in the curing stage to maintain an aerobic environment and to promote drying. Unscreened or screened compost can be cured, but curing screened compost requires less area. Tables 4-6 through 4-8 summarize advantages and disadvantages associated with each composting system.

FIGURE 4-1 COMPOSTING GENERALIZED FLOW DIAGRAM

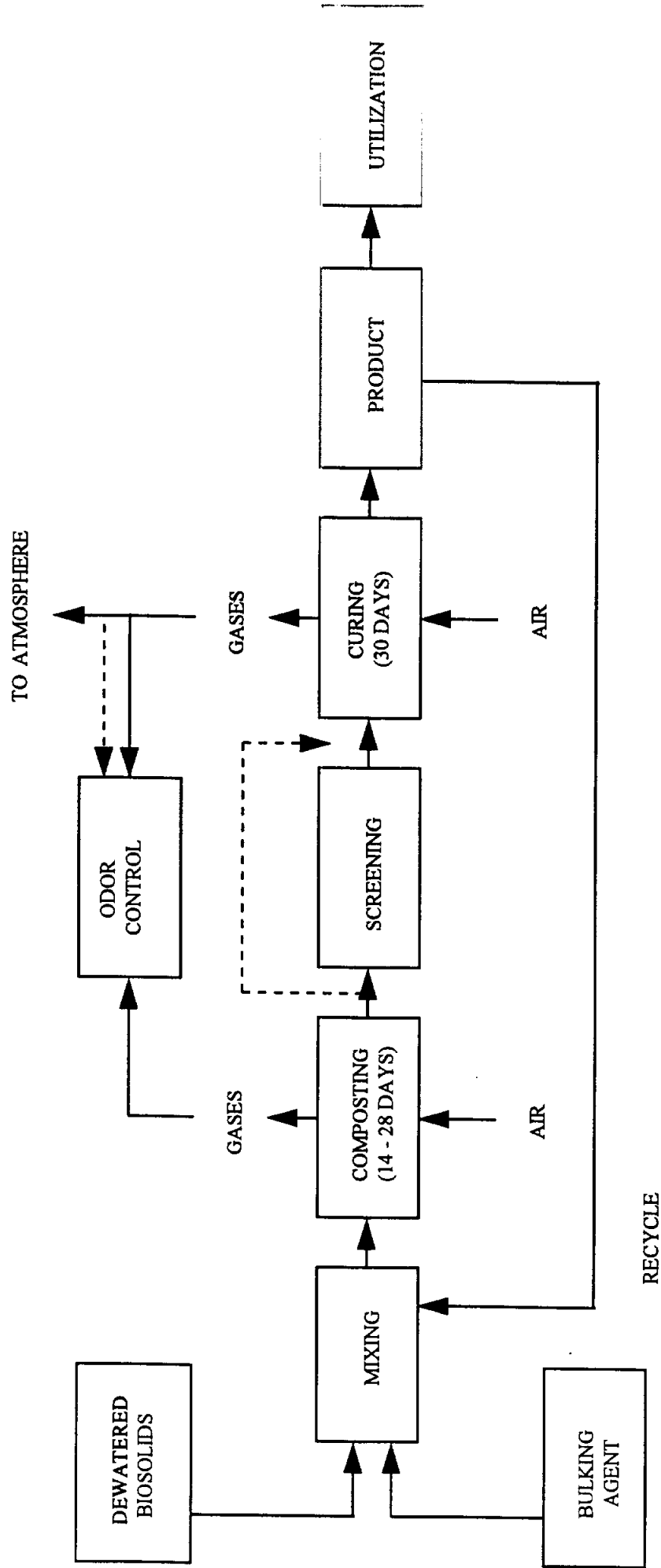

TABLE 4-6

ADVANTAGES AND DISADVANTAGES OF WINDROW COMPOSTING

ADVANTAGES	DISADVANTAGES
<ul style="list-style-type: none">• Simple treatment process to install and operate• Adaptable to various bulking agents• Flexibility to handle changing feed conditions• Turning action promotes good drying which facilitates screening• Relatively low capital investment (if outdoors)• Turning action homogenizes compost• Turning action results in some size reduction• Good ability to maintain throughput• Dilution of biosolids contaminants	<ul style="list-style-type: none">• Requires largest area per ton of biosolids processed• Odor "peaks" are released during each pile turning operation• Requires careful monitoring to insure temperature levels throughout are adequate for pathogen destruction• Employs high maintenance equipment• May require disinfection to destroy pathogens• Large quantity of end product per dry ton processed• Operators are exposed to composting material• Effectiveness is subject to weather conditions (if outdoors)

TABLE 4-7
ADVANTAGES AND DISADVANTAGES OF AERATED STATIC PILE
COMPOSTING

ADVANTAGES	DISADVANTAGES
<ul style="list-style-type: none"> • Relatively low capital investment (if outdoors) • Simple treatment process to install and operate • Effective pathogen destruction • Better odor control than windrow systems • Relatively easy to enclose • Adaptable to various bulking agents • Shortened processing time • Good control of temperature and aerobic conditions • Good ability to maintain throughput • Dilution of biosolids contaminants 	<ul style="list-style-type: none"> • Requires significant land area • Effectiveness is subject to weather conditions (if outdoors) • Odors can be more difficult to control than in some in-vessel systems (unless indoors) • Large quantity of end product per dry ton of biosolids processed • More labor-intensive than conventional windrow technology • Operators are exposed to composting material

TABLE 4-8
ADVANTAGES AND DISADVANTAGES OF
AGITATED BED COMPOSTING SYSTEMS

IN-VESSEL TECHNOLOGY	ADVANTAGES	DISADVANTAGES
<ul style="list-style-type: none"> • Horizontal agitated bed reactor 	<ul style="list-style-type: none"> • Can accommodate small particle size bulking agents • Repeated mixing action to eliminate dead spots and provide more uniform porosity • Flexibility in bin loading and agitation schedule permits remixing and modification of bulking agent to address variations in biosolids moisture • Automated temperature feedback aeration controls 	<ul style="list-style-type: none"> • Single outfeed device with some flexibility • Potentially dusty working environment • Fixed volume reactors. Limited capacity to handle changing feed conditions • Operators exposed to composting material surfaces for open bin type • Land area as great as with static pile

4.3.3.1 - Windrow Composting Systems

Windrow composting systems are non-proprietary and can be designed in a variety of configurations. Windrow composting of biosolids starts with the mixing operation, where biosolids are mixed with a dry compost or a bulking agent to reduce moisture and increase the structural integrity of the mix. This mixture is piled in long parallel rows or windrows. The size and shape of these rows is dictated by the slump characteristics of the mix and the turning equipment used for the pile aeration. The cross section of the windrow may be trapezoidal or triangular, depending on the characteristics of the mobile equipment used for turning the pile. Figure 4-2 shows a diagram of a typical windrow composting system.

The rows may be positioned over the grating of a submerged aeration system. Such a system is known as the *aerated turned windrow* process. Other windrows may be constructed on open, uncovered pads or under a roof. These rows are periodically turned and agitated by windrow turning devices. Some windrow turning machines straddle the pile and are propelled along the pile axis, while a powered auger digs at this pile base and discharges by conveyor to

FIGURE 4-2
WINDROW COMPOSTING SYSTEM

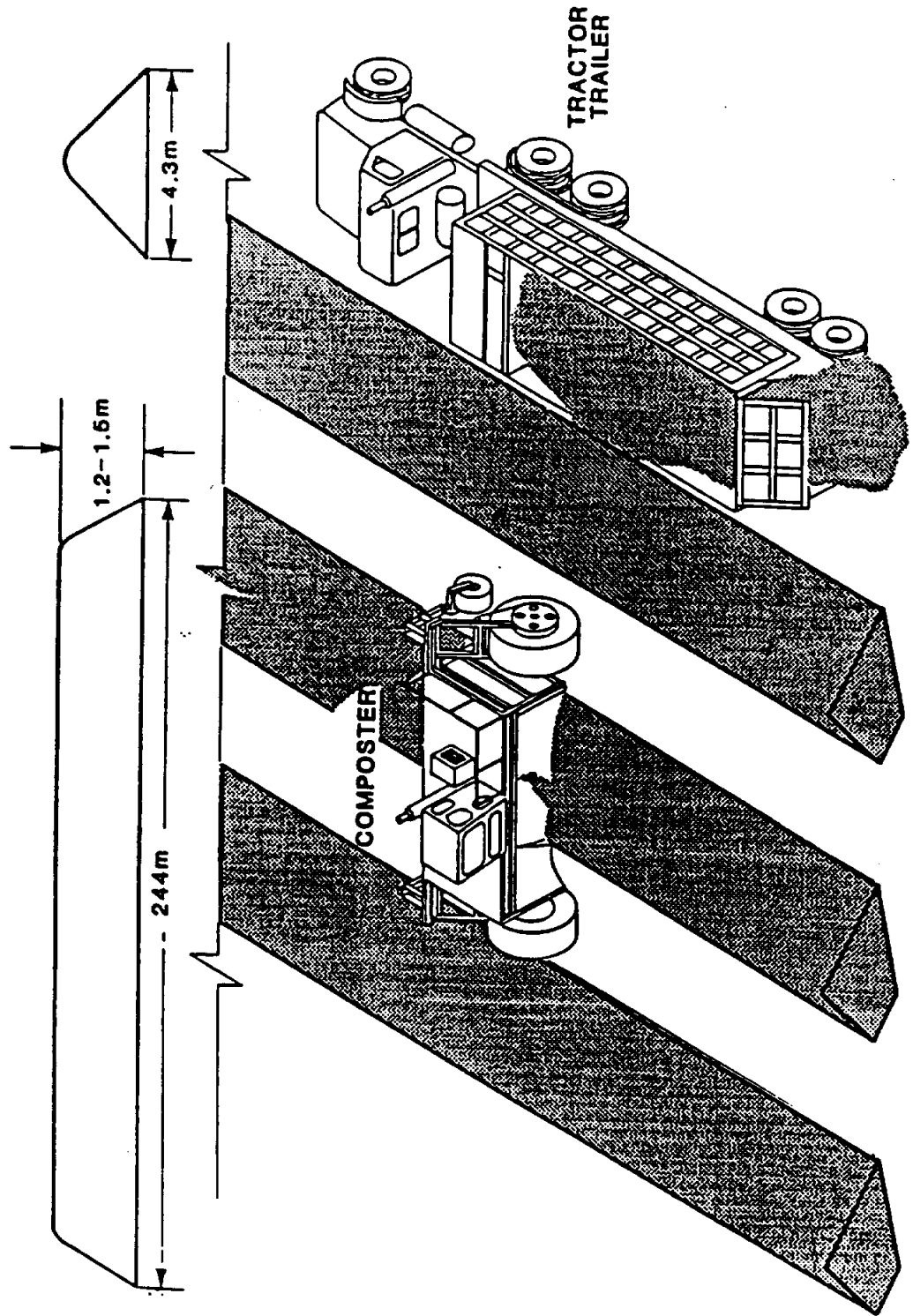

the rear of the machine. Other windrow turning devices are propelled by a tractor which travels down aisles between the piles. An action similar to the straddle machine excavation takes place. Some of these units discharge to the rear while others displace the pile axis sideways to a new position during each pass.

4.3.3.2 - Aerated Static Pile Systems

Aerated static pile systems are also non-proprietary technologies. An aerated static pile system was developed in order to eliminate many of the land and handling requirements of windrow composting as well as contain the odors generated during windrow turning events. The aerated static pile process also begins by mixing the biosolids with a carbonaceous bulking agent. Wood chips are the most commonly used bulking agent. Small to medium sized composting facilities use front end loaders or batch mixing boxes to combine these ingredients. Large scale composting facilities utilize paddle or pugmill mixers or plow mixers which operate in a continuous feed mode. Once the biosolids are thoroughly mixed with the bulking agent, it is deposited on a prepared layer of wood chips or other bulking material. This initial sub-base for the pile consists of a one-foot deep layer of wood chips in which perforated plastic aeration pipes have been immersed. Some systems utilize subsurface duct systems for aeration. This layer of wood chips acts as a diffuser for the air used in aerating the pile. The width of this base varies with the specific design. The biosolids/bulking agent mixture is formed into a six to 12-foot high pile. The front-end loader operator covers this pile with a layer of compost which acts as an insulation layer and an odor scrubber at the surface of the pile. To reduce labor requirements, some aerated pile installations utilize belt conveyor systems to distribute compost and form the piles. The pile remains intact typically for a period of 21 to 28 days during which time microbial action degrades the organic compounds with an accompanying release of energy.

This energy raises the pile temperatures to a level (50°C to 60°C) which eliminates the pathogens present in the biosolids. Since the composting process requires oxygen to digest organic substances, low pressure blowers are connected to the air distribution system. The blowers are used to either force or draw air through the pile. Temperature control can be achieved by varying the time period during which aeration takes place. Temperature feedback

control systems are increasingly common in these type of systems. Daily measurements of the pile temperatures are used by the operator to control the process and assure adequate temperature levels for pathogen destruction. Once the composting period is complete, the compost material is removed from the active area to a curing pad where some additional breakdown and drying will occur. This curing may extend from 30 to 60 days.

The usage of the compost may require further processing steps. In addition, if a reclaimable bulking agent, such as wood chips or rubber tire fragments, is present in the compost, screening will be necessary to reclaim the bulking agent. Wood chip recoveries of 70 to 80 percent (based on initial bulking agent volume) can be obtained in some cases. Most commonly, the compost is screened prior to curing. This reduces the volume of the curing pile and limits the breakdown of the bulking agent. Compost cannot be screened if the moisture content exceeds 45 to 50 percent. An additional drying step with very high rate aeration is sometimes included between composting and screening. Equipment typically used for separating compost and bulking agent in municipal biosolids composting applications includes vibrating deck and trommel screens. Figure 4-3 shows a diagram of a typical static pile composting system.

4.3.3.3 - In-Vessel Composting Systems

In-vessel composting systems follow a route similar to that employed in windrow and aerated static pile systems for mixing the biosolids with a bulking agent to produce the desirable level of moisture, provide a source of carbon, and improve the mix porosity. In-vessel composting systems are proprietary and are offered by a large number of companies. The variety of in-vessel systems available can differ significantly in design and layout offering unique advantages and disadvantages to each system. In-vessel systems can be divided into three general categories which include:

- Vertical reactors
- Horizontal non-agitated reactors
- Horizontal aerated agitated bed reactors

FIGURE 4-3

EXTENDED AERATED STATIC PILE COMPOSTING

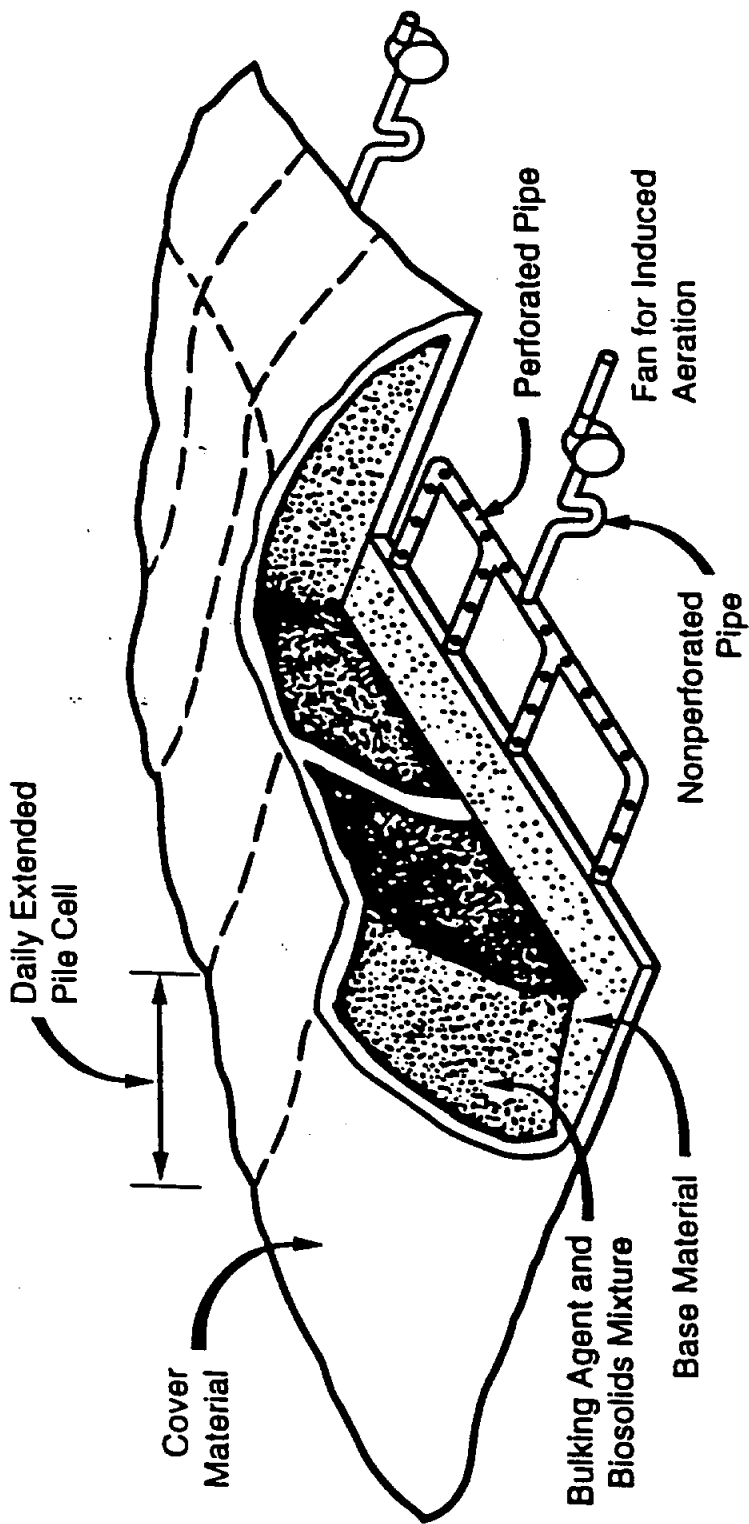

Aerated agitated bed systems are the only in-vessel systems which are addressed as part of this work scope. This is due to their greater success in municipal applications over recent years as compared to other in-vessel systems.

Horizontal aerated agitated bed systems consist of a series of parallel, open top concrete bins loaded at one end and discharging at the other. The bin cross section varies from six to 20 feet wide and six to ten feet deep. The bin length is dependent on the rate of movement and the desired number of days required for the process. Typical bin lengths vary from 100 to 200 feet. The material to be composted is deposited at the feed end of this bin or trough. A mechanical mixing aerating device travels the full length of each bin on a daily basis. As this excavator unit moves down the length of the bin, it digs up and redeposits the full content of the trough and moves it towards the discharge. The daily advance of the compost is usually ten to twelve feet. Each bin is equipped with an automated aeration system which provides oxygen and controls temperature of the bin contents. These controls are usually linked to a computer controller for complete data recording and process control capability. The following are some of the horizontal agitated bed systems:

- Paygro
- OTVD Systems
- International Process Systems (IPS)
- Longwood
- Taulman

Agitating mechanisms and the feed (mix) input point into the reactor vary in these systems. A typical horizontal agitated bed system is shown in Figure 4-4.

4.4 - COMPOSTING TECHNOLOGIES ASSESSMENT

This section of the report summarizes key factors involved in designing and operating composting facilities. Information was gathered through the use of telephone surveys, site visits, and literature review and is described in the following sub-sections. A brief plant description of the facilities surveyed is provided at the end of this section.

FIGURE 4-4

AGITATED BED TYPICAL CONFIGURATION

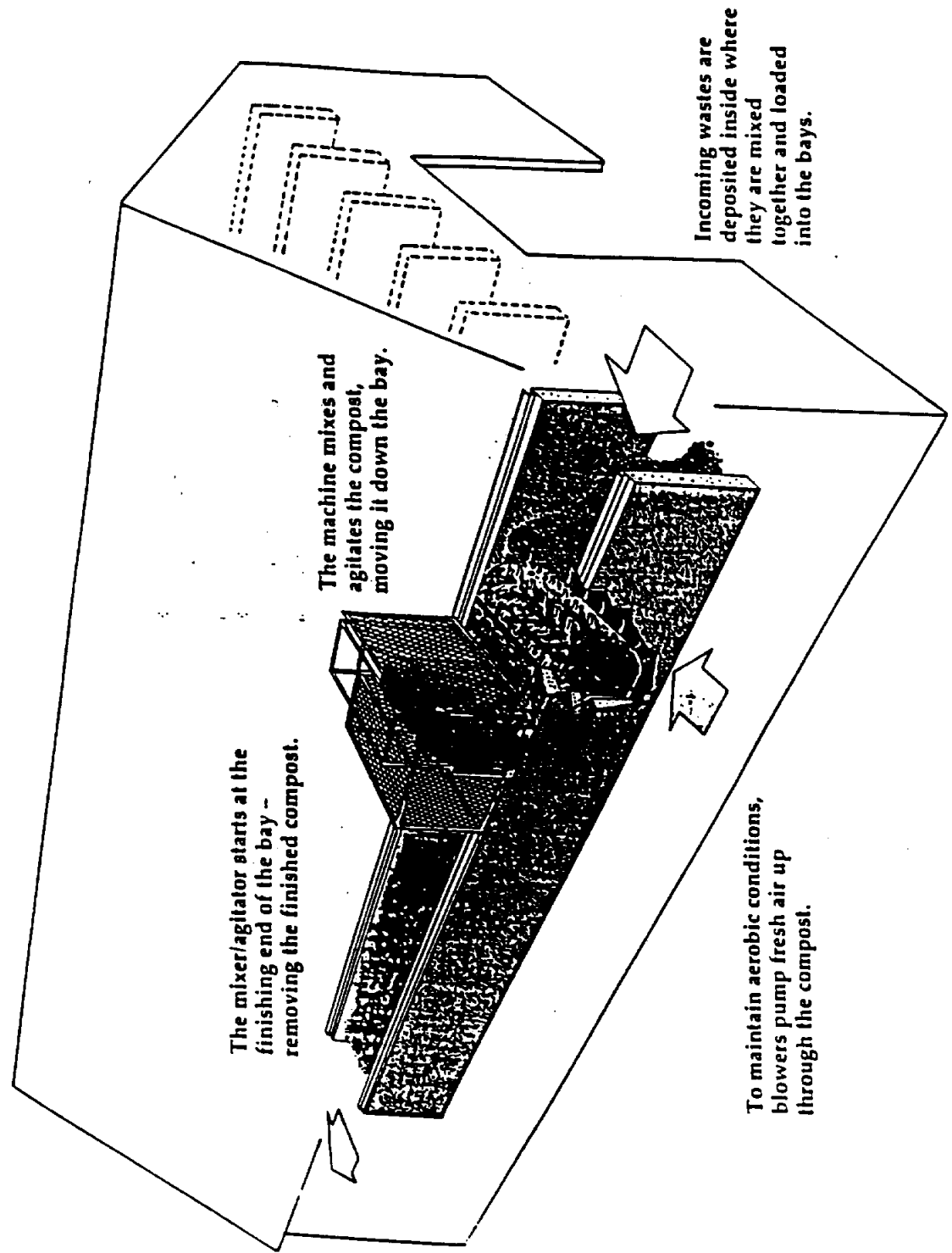

4.4.1 - Area Requirements

Significant variations in the area requirements for a composting facility exists from facility to facility. Exact acreage is difficult to obtain for facilities that adjoin the WWTP's. Other factors effecting facility land requirements include the size of storage areas, leachate collection ponds, the odor control technology utilized, and buffer areas to the site perimeter.

Buffer areas are controlled by facility location. Facilities at WWTP's may require minimal buffering areas above that of the treatment plant, while facilities at remote sites may require 200 or more feet from the processing area to the site perimeter.

In general, the windrow facilities require the most acreage per dry ton, with aerated static pile and aerated agitated bed facilities requiring approximately the same area. The land requirements for each of the technologies is shown in Table 4-9.

**TABLE 4-9
COMPOST FACILITY LAND AREA REQUIREMENTS**

Technology	Range of Area Requirement (Acre per dry ton per day of biosolids capacity)	Average Area Requirements (Acre per dry ton per day of biosolids capacity)
Aerated Agitated Bed	0.39 - 0.56	0.48
Aerated Static Pile	0.27 - 0.54	0.39
Aerated Windrow	0.51 - 0.67	0.59

Land area requirements for aerated agitated bed facilities range from 0.39 to 0.56, with an average of 0.48 acres per dry ton per day of biosolids capacity. Land area requirements for aerated static pile facilities range from 0.27 to 0.54, with an average of 0.39 acres per dry ton per day of biosolids capacity. Land area requirements for aerated and unaerated windrow facilities range from 0.51 to 0.67, with an average of 0.59 acres per dry ton per day of biosolids capacity.

4.4.2 - Site and Utility Requirements

Site and utility requirements vary from facility to facility. For example, facilities located at WWTP's may not require additional site fencing, access roads, security gates, or administrative buildings, while remote facilities may require all of these. Desirable site features for a compost facility include:

- Near biosolids production facility to minimize transport costs
- Access roads capable of handling heavy truck traffic
- Compatible neighboring facilities (i.e., industrial type operations or farm land)
- Minimal site elevation deviations
- Soils adequate to support structures and heavy equipment traffic
- Access to existing utility lines such as water and electricity

Most of these requirements can be satisfied when facilities are located near WWTP's.

As a minimum, water and electricity must be provided to the composting facility. Water is used for several activities including equipment and site washdown, personnel usage, some types of odor control systems, and some composting technologies. Often times a combination of potable water and effluent water are sometimes utilized to meet the water demand and reduce potable water costs.

Most facilities use electrically driven equipment during the composting process. This equipment may include blowers, pumps, materials handling equipment, controls, and lights. In addition, the following utilities may be required:

- Telephone
- Natural gas
- Diesel fuel storage
- Sanitary sewer/septic system
- Truck scales
- Leachate Collection

Telephone access should be provided at the compost site to allow for coordination of materials movement to and from the site and for general information flow. Natural gas may be required for heating of personnel areas and equipment rooms. Diesel fuel storage on-site can normally be accomplished through above-ground storage tanks. Diesel storage will provide the operator flexibility in mobile equipment operations and prevent potential scheduling conflicts with refueling trucks. Sanitary sewer or a septic system will be required for personnel working at the

facility depending on availability of such services at nearby facilities. Truck scales may be required to monitor quantities of materials arriving at and being removed from the facility. Truck scales allow more exact and efficient materials handling recordkeeping, although many facilities monitor material flow by volume. Leachate collection is required for condensate from the composting process as well as runoff from outside storage pads. Several types of treatment are possible to include the use of siltation ponds and discharge to sanitary sewer lines. Many of the utility requirements are site specific, as well as specific to operator preference and budget constraints. Storm water runoff control is also required at compost sites.

4.4.3 - Capital and Operating Costs

A wide variation in capital investment results from site acquisition costs, site preparation costs, technology selected, size of facility, and level of process and odor control utilized. In general, facilities located adjacent to wastewater treatment plants (WWTP's) are less expensive to construct due to less site preparation costs such as utilities and roads. From a technology standpoint, aerated agitated bed facilities are generally the most expensive to construct, followed by aerated static pile facilities, aerated windrow facilities, and then unaerated windrow facilities. The actual capital cost varies widely based on specific facility requirements. To compare facility costs 1996 Means Building Construction Cost Data historical, and city cost indexes were used to compare capital costs from existing facilities to the Austin, Texas area in 1996.

Capital costs for aerated agitated bed facilities range from \$306,000 to \$660,000 per dry ton per day of biosolids capacity, with an average of \$493,000 per dry ton per day of capacity. Capital costs for aerated static pile facilities range from \$223,000 to \$629,000 per dry ton per day of capacity, with an average of \$333,000 per dry ton per day of capacity. Capital costs for windrow facilities range from \$13,000 to \$123,000 per dry ton per day of capacity, with an average of \$68,000 per dry ton per day of capacity.

Operating and maintenance (O&M) costs vary from facility to facility with the two main components being labor and bulking agent. Some facilities accept yard wastes and process the material, while other facilities purchase high quality wood chips. The O&M costs for the aerated agitated bed facilities range from \$109 to \$175, with an average of \$144 per dry ton of biosolids

processed. The O&M costs for aerated static pile facilities range from \$137 to \$214, with an average of \$164 per dry ton of biosolids processed. The O&M costs for windrow facilities range from \$69 to \$125, with an average of \$93 per dry ton of biosolids processed.

4.4.4 - Environmental and Odor Control

The primary environmental concerns regarding operation of biosolids composting facilities is that of surface water runoff from processing areas and odor control. Surface water runoff from active processing areas should be collected and treated to minimize any surface water pollution. Typically, biosolids composting facilities are operated on impervious pads such as clay lined or even asphalted and concrete paved surfaces. Any leachate, condensate or runoff from these process areas should be collected and treated prior to discharge. This is typically done through discharge to sewers or pump and haul operations at remote sites to take in treated water to a permitted wastewater facility. Storm water collection and treatment is typically practiced through the use of siltation ponds from areas where compost and or bulking agents are stored both before and after processing. Roofed areas at composting facilities minimize the amount of surface water runoff which requires collection and treatment. In these cases, the majority of any water from any composting site would be from roof or paved storage areas, thereby requiring only good storm water collection practices.

Odor control from composting facilities is perhaps the most pervasive issue of concern in the industry today. Because of the nature of biosolids and other putrescible materials, odor generation at composting facilities is common. The amount of odor which can be tolerated at composting facilities is impacted by a number of factors such as:

- The type of material being processed
- Quantity of material being processed
- The type of composting technology employed
- The degree to which a composting facility is enclosed
- Buffers surrounding the facility
- Micro-climate near the facility

Odor control at composting facilities involves process adjustment, enclosure, and finally collection and treatment of odorous gases. The natural degradation of organic material will generate sulfur and nitrogenous laden compounds such as dimethyl sulfide, ammonia, and amines in minute quantities. The presence of these compounds at these extremely low concentrations does not pose a health risk. However, these compounds are extremely pervasive even at low concentrations and can be detected and perceived to be highly odorous. For these reasons, many facilities being operated or planned must consider the impact that odors may have on surrounding property owners.

Process adjustments have been somewhat successful in reducing odor generation at composting facilities. Using good operational practices can, indeed, minimize odor generation. However, odor generation will be present even at a very well run and operated composting facility. Odors are typically associated with the wet stages in the composting process. Consequently, many facilities have placed roofs over portions of the composting process to minimize the impact from weather. However, until facilities are enclosed and exhaust gases collected and treated, these odors can still escape from an operating facility and be carried offsite where receptors may notice them. An increasingly common trend, therefore, is to totally enclose composting facilities and to treat off gases through some method of either chemical scrubbing or biofiltration system. Chemical scrubbing utilizes complex chemistries and acidic or caustic chemicals to scrub odorous gases out of an airstream. These systems are expensive to install and operate and require substantial quantities of water and chemicals to operate. Biofiltration is a method whereby odorous gases are treated through a media of organic material such as well stabilized compost and woodchips. The use of biofiltration systems is increasingly common at composting and other facilities for odor control. Biofiltration systems tend to be significantly less costly to operate than a wet chemical scrubbing system. However, they require significantly larger land area than a chemical scrubbing system, and therefore, are used on a site specific basis. Totally enclosed composting facilities which treat off gases in this manner typically have experienced very few odor problems except where fugitive gases continue to be released from some point in the process that is not effectively collected. The primary consideration in looking at odor control is the quantity of material being processed, the location of the site, and the buffer

area around the existing operation which can disperse odors prior to them being carried to a receptor.

In the site selection and design stages of project development, odor modelling can be performed to compare various facility types, layouts, and treatment options and the impact on odors to surrounding neighbors. In this way, non-acceptable scenarios can be screened out and only acceptable scenarios with minimal odor impact can be evaluated and developed. This practice is highly beneficial and recommended for the development of new composting facilities to ensure odor nuisances do not occur.

4.4.5 - Staffing Requirements

Labor is normally a large component of the O&M costs for composting facilities. The number of personnel at a specific facility varies for several reasons. In some cases, the composting facility is totally separate from the WWTP and the operating staff must include a maintenance force whose total assignment rests with the composting operation. Other facilities located near the wastewater treatment facility site share maintenance crews with the treatment facility. Another factor affecting staffing levels at operating facilities is whether the facility was designed for a larger tonnage than that presently being processed. This results in a high ratio of personnel to dry ton of biosolids processed. Table 4-10 shows the range of staffing requirements for the different technologies.

**TABLE 4-10
COMPOST FACILITY STAFFING REQUIREMENTS**

Technology	Staffing Range (persons per dry ton of biosolids capacity)	Staffing Average (persons per dry ton of biosolids capacity)
Aerated Agitated Bed	0.20 - 0.50	0.31
Aerated Static Pile	0.27 - 0.63	0.43
Aerated and Un-aerated Windrow	0.27 - 0.59	0.43

Staffing requirements for aerated agitated bed facilities range from 0.2 to 0.5 persons per dry ton of biosolids capacity, with an average of 0.31. Staffing requirements for aerated static pile facilities range from 0.27 to 0.63 persons per dry ton of biosolids capacity, with an average of 0.43. Staffing requirements for windrow facilities range from 0.27 to 0.59 persons per dry ton of biosolids capacity, with an average of 0.43.

4.4.6 - Summary of Comparable Biosolids Composting Facilities

The following section summarizes data on existing comparable biosolids composting facilities throughout the United States. The technologies summarized include aerated agitated bed facilities, aerated static pile facilities, aerated windrow facilities, and unaerated windrow facilities. Data was obtained from telephone survey, site visits, and a review of the literature. Table 4-11 shows a summary of this evaluation and the data which was obtained.

4.4.6.1 - Aerated Agitated Bed Facilities

Lewiston-Auburn, Maine - The composting facility in Lewiston-Auburn, Maine utilizes the aerated agitated bed process to compost 10 DTPD of 20.5% total solids dewatered municipal biosolids. Composting and mixing occur in a totally enclosed building with ventilation treated through a biofilter. The facility has six composting bays and two agitators. Wood shavings are utilized as the bulking agent. After discharge from the bay, the material is further aerated for final curing. The facility was constructed for \$6.8 million in 1993. Compost operating costs are approximately \$116 per dry ton of biosolids.

State College, Pennsylvania - The composting facility in State College, Pennsylvania utilizes the aerated agitated bed process to compost 10 DTPD of 21% total solids dewatered municipal biosolids. Composting occurs in a totally enclosed building with biofiltration for odor control. The facility has 12 bays and three agitators. Sawdust is utilized as the bulking agent. The facility was constructed for \$6 million in 1992. Compost operating costs are approximately \$161 per dry ton of biosolids.

Lockport, New York - The composting facility in Lockport, New York utilizes the aerated agitated bed process to compost 14 DTPD of 20% total solids dewatered municipal biosolids.

Table 4-11
COMPOST FACILITY SUMMARY

Facility	Design Capacity (DTPD - 5 days per week)	Biosolids %TS	Year On-line	Capital Cost (\$million - start-up year)	Capital Cost (1996 in Austin, TX) \$ million	O&M Cost (\$/DT)	Staff Requirements	Site Area (Acres)
AERATED AGITATED BED								
Lewiston-Auburn, Maine	10	20.5	1993	6.8	6.6	116	2	108
State College, Pennsylvania	10	21	1992	6.0	5.64	161	5	5
Lockport, New York	14	20	1991	5.82	5.20	171	4	---
Merrimack, New Hampshire	15.5	21	1994	5.37	4.74	109	3.5	6
West Palm Beach, Florida	25	12 - 22	1994	13.0	12.86	150 - 175	---	14
AERATED STATIC PILE								
Davenport, Iowa	28	20	1995	8.5	7.59	137	10	15
Philadelphia, Pennsylvania	280	25	1989	77.3	69.3	350*	175	---
Montgomery County, Maryland	80	20	1988	46.54	50.3	325*	47	---
Blue Plains, Washington, D.C.	55	20	1989	12.08	12.27	214	16	15
Harrisonburg, Virginia	5.5	23	1995	1.51	1.61	140	1.5	2
AERATED WINDROW								
Denver, Colorado	147	20	1986	17.0	18.13	---	40	75
Upper Occoquan, Virginia	15	22	1991	---	---	---	---	---
UNAERATED WINDROW								
Belton, Texas	2.4	15.5	1990	---	---	69	2	---
San Joaquin, California	120	24	1990	1.95	1.60	108 - 125	---	80

*Includes dewatering costs

Composting occurs in a totally enclosed building with ventilation treated through a biofilter. The facility has 12 bays and three agitators. Wood chips are utilized as the bulking agent. The facility was constructed for \$5.82 million in 1991. Compost operating costs are approximately \$171 per dry ton of biosolids.

Merrimack, New Hampshire - The composting facility in Merrimack, New Hampshire utilizes the aerated agitated bed process to compost 15.5 DTPD of 21% total solids dewatered municipal biosolids. Composting occurs in a totally enclosed building with ventilation through a biofilter. The facility has 15 bays and three agitators. The facility was constructed for \$5.37 million in 1994. Compost operating costs are approximately \$109 per dry ton of biosolids.

West Palm Beach, Florida - The composting facility in West Palm Beach, Florida utilizes the aerated agitated bed process to compost 25 DTPD of 12% to 22% total solids dewatered municipal biosolids. In 1991, four bays were constructed on a covered pad as a pilot project. In 1994, an additional 32 bays were added to increase capacity to full-scale. Composting occurs in a totally enclosed building with ventilation through biofilter. Yard wastes are processed at the facility and used as the primary bulking agent. The facility has a total of 36 bays and nine agitators. The 32 bay facility expansion was constructed for \$13.0 million in 1994. Compost operating costs are approximately \$150 to \$175 per dry ton of biosolids.

4.4.6.2 - Aerated Static Pile Facilities

Davenport, Iowa - The composting facility in Davenport, Iowa utilizes the aerated static pile process to compost 28 DTPD of 20% total solids dewatered municipal biosolids. The mixing and composting areas are totally enclosed with odor control of all building ventilation and process gas through biofiltration. The screening, curing, and bulking agent storage areas are covered. The facility utilizes a mobile grinder to process yard wastes, combined with wood chips and shredded tires, for use as a bulking agent. The facility was constructed for \$8.2 million in 1995. Compost operating costs for composting are approximately \$137 per dry ton of biosolids.

Philadelphia, Pennsylvania - The composting facility in Philadelphia, Pennsylvania utilizes the aerated static pile process to compost 280 DTPD of 25% total solids dewatered municipal biosolids. The mixing area is totally enclosed. Composting and screening occur on

an open pad. Curing and product storage are on a covered pad. The facility was constructed in 1989 at a cost of \$77.3 million. The operating costs are \$350 per dry ton of biosolids, which includes dewatering.

Montgomery County, Maryland - The composting facility in Montgomery County, Maryland utilizes the aerated static pile process to compost 80 DTPD of 20% total solids dewatered municipal biosolids. The biosolids are mixed with wood chips and composted in a totally enclosed building. The compost process gas is collected and treated through a chemical scrubber system. Screening and curing is performed in a totally enclosed building. The facility was constructed in 1988 at a cost of \$46.5 million. Compost operating costs are approximately \$325 per dry ton, which includes dewatering.

Blue Plains, Washington, D.C. - The composting facility in Washington, D.C. utilizes the aerated static pile process to compost 55 DTPD of 20% total solids dewatered municipal biosolids. Composting occurs on a covered pad and no active odor control is performed. Wood chips are utilized as the bulking agent. The facility was constructed at a cost of \$12.1 million. Compost operating costs are approximately \$214 per dry ton.

Harrisonburg-Rockingham Regional Sewer Authority (HRRSA), Virginia - The HRRSA composting facility located in Mount Crawford, Virginia utilizes the aerated static pile process to compost 5.5 DTPD of 23% dewatered municipal biosolids. The mixing, composting, screening, and curing operations are performed on a covered pad. The compost process gasses are collected and treated through biofiltration. Wood chips are utilized as the bulking agent. The facility was constructed in 1995 at a cost of \$1.51 million. Compost operating costs are estimated to be \$140 per dry ton.

4.4.6.3 - Unaerated Windrow Facilities

Brazos River Authority, Belton, Texas - The Brazos River Authority composting facility began operations in 1990 utilizing the unaerated windrow process to compost 3.4 DTPD of 15.5% total solids dewatered municipal biosolids. The aerated biosolids were mixed with wood chips and wood shavings and placed in windrows. The windrows were located on a covered pad. In 1994, the facility converted operations to an aerated static pile/windrow combination process

to reduce odor emissions. Operating costs were estimated to be \$69 per dry ton prior to converting operation to an aerated static pile/windrow combination process.

San Joaquin, California - The Cities of Los Angeles, Fresno, and Pismo Beach transport biosolids and yard waste to the San Joaquin Composting Facility located near Lost Hills, California. The facility utilizes the unaerated windrow process to compost 120 DTPD of 24% total solids dewatered municipal biosolids. Yard wastes are used as the primary bulking agent and finished compost is sold in both bag and bulk. The windrows are constructed on an open pad. The facility was constructed in 1990 for a capital cost of \$1.95 million. Operating costs for the facility are estimated to range from \$108 to \$125 per dry ton of material composted.

4.4.6.4 - Aerated Windrow Facilities

Denver, Colorado - The Denver, Colorado composting facility began operations in 1986 utilizing the aerated windrow process. The facility was designed to compost 147DTPD of 20% total solids dewatered municipal biosolids. The dewatered biosolids were mixed with wood chips and/or sawdust and placed in windrows located on a covered pad. The facility experienced odor problems and currently operates at significantly less than the design capacity. The facility was constructed in 1986 for a capital cost of \$17.0 million.

Upper Occoquan, Virginia - The composting facility located in Upper Occoquan, Virginia utilizes the aerated windrow process to compost 15 DTPD of 22% total solids dewatered municipal biosolids. The dewatered biosolids are mixed with finished compost and placed in windrows over a straw aeration plenum. The facility was constructed in 1991.

4.5 - COMPARISON OF LAND APPLICATION VS. COMPOSTING

Table 4-12 summarizes the advantages and disadvantages of land application vs. composting of biosolids. The primary difference between the technologies is that land application requires minimal capital investment, is a simple, low-cost alternative, and can be implemented in a very short time frame. Composting, on the other hand, requires much less land area than land application and can produce a product which has multiple uses. Composting has the added benefit of processing other potential waste material such as yard waste since it is required as a

bulking agent for dewatered biosolids. Another clear advantage of land application for those facilities which do not have a form of dewatering is that land application can be conducted on a liquid biosolids material. Composting, on the other hand, requires that a dewatering or drying bed operation be in existence in order for a cost effective program to result. Composting can be accomplished year round, whereas land application is dependent on fitting in with agricultural demands and weather factors. Finally, the odors associated with biosolids can be controlled with composting but can be problematic with land spreading if neighbors are close to the application fields. Some combination of these types of programs is commonly practiced at many facilities to allow flexibility for changing regulations, changing weather conditions, and other pressures as they develop. Chapter 6 of this report discusses the rationale for the recommended programs which will be compared on a cost basis.

TABLE 4-12

ADVANTAGES AND DISADVANTAGES OF LAND APPLICATION VS. COMPOSTING
DIRECT LAND APPLICATION **COMPOSTING**

ADVANTAGES	DISADVANTAGES	ADVANTAGES	DISADVANTAGES
<ul style="list-style-type: none"> • Simple alternative • Low cost alternative • Does not require dewatering of biosolids • Maintains nutrients in biosolids 	<ul style="list-style-type: none"> • Significant land area requirements • Potential permitting/monitoring of multiple sites • Potentially affected by weather • Transportation intensive • Potential odor impacts • Significant public education/Public concern over multiple sites • No elimination of pathogens • Dilution of contaminants not possible • No reduction in volume • Impacted by crop requirements, therefore need storage either in the field or at treatment plant 	<ul style="list-style-type: none"> • Simple technology • Versatile, aesthetically pleasing product • Eliminates pathogens • Dilution of contaminants possible 	<ul style="list-style-type: none"> • Labor, material, and transportation intensive • No reduction in volume (1 Dry Ton biosolids = 5 - 6 cubic yards product) • Odor production may require enclosures and treatment

5.0 - MARKET RESEARCH

The market research for the Travis and Williamson County Biosolids Study includes three issues:

- Regional Markets for Compost
- Potential Sources of Bulking Agent for Composting
- Land Resources for Land Application or Composting

The following sections address these issues.

5.1 - LCRA BIOSOLIDS COMPOST MARKETING RESEARCH

In order to better understand the marketability and the parameters necessary to distribute a LCRA produced biosolids compost, preliminary market research was completed by E&A Environmental Consultants, Inc. (E&A). The goal of the preliminary market research was to obtain relevant data regarding planning and implementing a compost marketing program in the Travis and Williamson County areas. Through telephone surveys, information was obtained regarding compost end use, seasonality of use, annual demand, quality requirements, and pricing information. Market segments contacted during the study include landscapers, nurserymen (wholesale growers), garden centers (retail nurseries), topsoil dealers, and landscape materials suppliers. In order to estimate current compost demand in the greater Austin area, 15% (minimum) of the firms within each individual market segment were contacted. This enabled us to complete a quantitative analysis which is statistically defensible.

The Austin, Texas area is home to a very strong landscape/nursery industry which has become well-acquainted with the use of organic soil amendments. This is likely due to the lack of natural rainfall and the poor quality of local soils. The soils were often described as sandy, loamy, or rocky, being low in organic matter and typically alkaline (limestone based).

5.1.2 - Market Segments

During market research, four primary markets were investigated to obtain both qualitative and quantitative market information. These four market areas are landscapers and lawn care (landscapers), retail nurseries or garden centers (garden centers), wholesale nurseries (growers), and topsoil dealers and commercial product wholesalers (landscape materials suppliers).

Information specific to each of the four market segments will be described in the following sections.

5.1.2.1 - Landscapers

The landscaping industry in the Austin area is thriving and the use of soil amendments in various applications is very popular. Composts produced from various agricultural and urban by-products have been avidly used in both bulk and bagged form. Of the landscapers interviewed, 89% (31 of 35) are currently using compost to some degree. Approximately half of the landscapers using compost are using substantial amounts on a yearly basis (from fifty to several thousand cubic yards). Although some compost is being used in turf establishment, the majority of product is being used as turf topdressing in established turf areas and in planting bed establishment. The compost is either applied to the native soil and incorporated or is being blended with other materials to produce a high organic content garden soil. Compost products produced from cow and turkey manure, biosolids, mushroom soil, and cotton burrs are the most popular products locally available. Compost is marketed to the landscape industry directly from compost manufacturers and through landscape material suppliers and garden centers. Several of the larger compost suppliers in the Travis and Williamson County area can be found in Table 5-3. Compost products are being sold for between \$7 and \$33.50 per cubic yard, picked up. Garden Ville of Austin and Whittlesey's Landscape Supply appear to be the largest local distributors of compost products as well as soil blends. Although we estimate that over 50,000 cubic yards of compost is marketed locally within the landscape industry, it is likely that a much greater amount is distributed as a component in manufactured soil blends.

There is wide acceptance of compost use in the landscape industry and there appears to be little phobia toward the use of biosolids products. However, several individuals stated they would not suggest a biosolids product be used where food crops are grown. Several comments suggest that Dillo Dirt is the product of choice for use as a turf topdressing. It should be reiterated that although a large percentage of the compost marketed is used in garden bed preparation, the majority of landscapers preferred to use a pre-blended material so soil

incorporation does not have to be completed at the jobsite. Landscapers are using compost products throughout the year, with peak seasons being the spring and the fall.

Many landscapers stated that they prefer compost products which are rich in organic matter, consistent in nature, well-composted/cured (not hot), rich in nutrition, and possessing no clumps, objectionable odors, or weed seeds. Some landscapers simply stated that they would use any product that was specifically specified on a project or that the customer requests. Landscapers who use the compost for topdressing wanted to make sure that it was fine and somewhat dry for ease of spreading.

5.1.2.2 - Growers

Local wholesale nurseries exist which produce nursery products in containers and in field production. There are also several large nursery wholesalers who stock and resell plant materials but do not grow them. It appears that little, if any, compost is being used in the production of nursery crops in the Austin area and little interest in its use currently exists. Most of the growers are utilizing pre-made planting media to grow their crops and, therefore, do not have the opportunity to use compost. Some, however, do produce their own blend on-site and could be compost users in the future. Currently, pre-made growing media are being marketed for between \$20 and \$50 per cubic yard, delivered. For all intents and purposes, consider the current market for compost use among growers as zero.

5.1.2.3 - Garden Centers

Within the Austin landscape/nursery sector, there is a strong garden center industry. Most garden centers distribute plant materials, gardening information and tools, as well as bagged and sometimes bulk products. Many garden centers also sell products to industry professionals, usually at a discounted price. Of the garden centers contacted during our survey, approximately 84% offer compost for resale in either bagged or bulk form. Of these, 25% carry both bagged and bulk compost, while approximately 56% carry only bagged and approximately 19% carry only bulk compost. The types of compost being distributed include mushroom soil, cotton burr, manure, and biosolids compost. Tables 5-1 and 5-2 provide detailed pricing information on bulk

and bagged compost products marketed through local garden centers. Compost products are being distributed at a picked-up price of between \$18 and \$34.95 per cubic yard, while bagged prices vary widely based on volume packaged. Great acceptance exists for the use and resale of compost through the garden centers. The majority see a great need in organically enriching the soil before establishing any plant materials. It is estimated that over 23,000 cubic yards of compost are currently marketed on a yearly basis through the Austin area garden centers in bulk form alone. It is estimated that if bagged compost and compost contained in soil blends were included, then the volume estimate would increase by 50% to 100% on an annual basis.

TABLE 5-1
RETAIL COMPOST PRICES¹ - BULK
(per cubic yard)

Compost Product / Feedstock	Price (Range)
Back-to-Earth (cotton burr)	\$21 - \$33
Bert's Dirts Manure Compost	\$28
Cotton Burr (from Amarillo)	\$27 - \$30
Cow manure (Geo Growers)	\$20 - \$33.50
Dillo Dirt (biosolids)	\$18 - \$22
Garden Compost ² (unknown)	\$32
Garden-Ville Compost (various ingredients)	\$32
Humisoil (manure/yard debris)	\$26
Living Earth Compost (Houston)	\$21
Manure (unspecified)	\$20 - \$24
Mushroom soil	\$21 - \$28
Turkey manure (Geo Growers)	\$32.12 - \$34.95
Whittlesey's Organic Compost (various ingredients)	\$30

Notes: ¹All prices picked up at retail location
²Product produced by AAA Grass and Landscape

TABLE 5-2
RETAIL COMPOST PRICES¹ - BAGGED

Compost Product / Feedstock	Size	Price (Range)
Back-to-Earth (cotton burr)	3 cubic feet	\$3.80 - \$7.59
Back-to-Earth (cotton burr)	5 gallons	\$1.35 ²
Cow manure (various brands)	40 pounds	\$1.69 ³ - \$2.49
Dillo Dirt (biosolids)	1 cubic foot	\$1.99 ³ - \$6.99
Earth Perfect Compost	1 cubic foot	\$5.49
Garden-Ville Compost (various ingredients)	80 quarts/20 gallons	\$10.75 - \$10.95
Garden-Ville Compost (various ingredients)	1 cubic foot	\$4.49 - \$4.99
Garden-Ville Compost (various ingredients)	5 gallons	\$1.35 ²
Turkey manure	80 quarts	\$10.95
Turkey manure	5 gallons	\$1.35 ²
Whittlesey's Organic Compost (various ingredients)	1 cubic foot	\$1.99 ³

Notes: ¹All prices are picked up at retail location
²All bag your own prices from Garden-Ville
³Pre-bagged by Whittlesey

5.1.2.4 - Landscape Materials Suppliers

The last market segment surveyed in this preliminary study was landscape materials suppliers. Several of these firms concentrate primarily on bagged products and tools, while others concentrate on bulk products. Within this category, the most important potential compost end users are topsoil dealers and bulk material yards and blenders. Both of these types of firms typically sell to both retail and wholesale customers, but to a large extent, the bulk material dealers primarily deal with the professional landscape industry. It has become obvious through research that the use of bulk soil mixes, which are modified and upgraded using compost, are extremely popular and commonly used materials throughout Austin. Although it is difficult to determine at this point, it is probable that more compost is used in the Austin area through the production of topsoil blends than is marketed unblended or straight to the landscape/nursery industry. Of the 15 companies contacted, approximately 47% (7 of 15) are selling or using compost in their operations. As the landscape industry has described, product is used on a year-round basis with peak usage in the spring and fall.

Preliminary estimates suggest that over 100,000 cubic yards of compost are used on an annual basis in this market segment. Wholesale compost prices range from \$7 to \$33.50 per cubic yard, picked up. Although several of these firms produce their own compost, the majority have firms which supply them with compost for resale and use. It should also be noted that several of these firms market more than one type of compost, along with several types of soil blends. Some also carry bagged compost products. Data in Table 5-3 outlines the compost types available through local bulk material yards and compost producers, as well as applicable wholesale pricing information. Wholesale pricing is only available to industry professionals.

TABLE 5-3
WHOLESALE COMPOST PRICES - BULK

	Feedstock (Price) ^a	Volume	Location	Other
Whittlesey Landscape Supply ^b	composted cow manure - \$17/yd ³ organic compost - \$25/yd ³ (manure, cotton seed hulls, wheat straw, etc) Dillo Dirt - \$15/yd ³	20,000/yd ³	Austin	Produces his own compost and distributes others, large soil blending business (probably 100,000 cubic yards or more per year)
Garden-Ville of Austin ^b	cotton burr compost - \$24.75/yd ³ turkey manure compost - \$27.50/yd ³ Dillo Dirt - \$15.50/yd ³	N/A	Austin	Distribute compost, main business in producing soil blends, probably largest firm in area, may start composting manure
Geo Growers	turkey manure compost - \$28.90/yd ³ dairy manure compost - \$33.50/yd ³	N/A	Austin	Distributes compost, main business is producing soil blends with compost
Hornaby Bend Compost Facility	biosolids compost - \$7/yd ³ to vendors and \$200 vendor fee	16,000-18,000 yd ³ (estimated for 1996)	Austin	Vendors sell to end users and through resellers, end users usually pay \$15-\$20/yd ³
Bert's Dirts	manure compost - \$28/yd ³	N/A	Austin	Claims to have been composting for 40 years, uses in soil blends also
Austin Landscape Supplies	manure compost - \$22/yd ³ Dillo Dirt	5,000-10,000 yd ³	Austin	Distributes compost, produces soil blends with compost

Notes: ^aAll quoted prices are wholesale, picked up.
^bPrice lists in Appendix
N/A - Not Available

Several landscape material wholesalers are bagging their own products, as well as products like Dillo Dirt for resale. Several of these firms, like several landscapers, consider Dillo Dirt or biosolids compost as an inexpensive but inferior alternative to some of the

agricultural by-product based composts currently available. Great opportunity lies in this market segment to resell LCRA compost on a large-scale basis, as well as use it in soil blends.

5.1.3 - Current Estimated Compost Demand

The preliminary quantitative data obtained during the market study illustrates a large and thriving compost market in the Austin area. Table 5-4 outlines a conservative estimate of just over 180,000 cubic yards of compost used on an annual basis, primarily purchased and resold in bulk form. This is considered a conservative estimate since it does not include the compost used and resold in bagged form or all of the compost contained in the production of soil blends. However, it could be argued that the compost use estimates developed for the landscape material suppliers represent the majority of that product. Regardless, considering these facts, as well as others, it is conceivable that the actual volume of compost used on an annual basis is closer to 300,000 cubic yards.

Current trends and attitudes observed during the market study suggest that compost use will continue to increase in the Austin area. It is also obvious that many of the firms utilizing compost are cognizant of quality issues and are willing to pay considerably for quality products.

TABLE 5-4

**PRELIMINARY CURRENT COMPOST USE ESTIMATES
FOR THE TRAVIS AND WILLIAMSON COUNTY AREA**

Market Segment	Annual Volume (cubic yards)
Garden Centers	23,358 ¹
Landscapers	53,000
Nurseries	0
Landscape Material Suppliers	106,586 ¹
Total Annual Cubic Yard	182,949

Notes: ¹Does not include compost marketed in bags by this market segment.

5.1.4 - Competing Products

As described in earlier sections, several large suppliers or sources of compost exist in the Austin area. The majority of the compost available is manure or cotton burr based. However,

biosolids and many products which are produced with a combination of feedstocks are also available. Products are available on a wholesale basis for as low as \$7 per cubic yard picked up (Dillo Dirt) and as high as \$29 per cubic yard. Although many compost products are available in the Austin area, the majority are priced high and are considered extremely high quality products. Outside of mushroom soil compost, which may enter the market at a cost comparable to Dillo Dirt, there is little competition for composts which are more economically priced. Although many firms support the Dillo Dirt program, several current customers complained that product quality has varied, paper work can be problematic, and no assistance is provided for trucking of the material. For these reasons, if the LCRA produces a consistently high quality compost product and works to provide improved customer service, they should be able to successfully compete with Dillo Dirt, especially if an upfront effort is made in establishing name recognition for their product.

5.1.5 - Conclusions

Many agricultural and urban by-products are being used as feedstocks for the production and sale of compost in the Austin, Texas area. Preliminary research estimates that between 200,000 and 300,000 cubic yards of compost are utilized annually in the greater Austin area in bulk, bagged, or blended condition. The greatest users of compost are landscape material suppliers, garden centers, landscapers, and of course the ultimate end user, homeowners. Compost products possess excellent value on both the wholesale and retail level, with wholesale prices ranging from \$7 to \$33.50 per cubic yard picked up. Retail prices range from approximately \$20 to \$35 per cubic yard picked up. Aside from the large bulk markets which currently exist, compost products are available in bagged and blended form. Because of Austin's warmer southern climate, the LCRA could expect to market its compost year round with peak usage in the spring and the fall. Poor soils and drought conditions make compost an ideal amendment for local soils. However, many landscapers and homeowners are not purchasing compost for incorporation into the soil. Instead, they are using blended topsoils since they are deemed more convenient to use. In landscape maintenance operations, compost, and particularly Dillo Dirt, is popular for use as a turf topdressing.

The robust local market leaves the LCRA with various opportunities for the distribution of their compost product. It is likely that the LCRA would be successful in marketing their product in bulk, bagged, or blended form using in-house staff, or working through outside firms who would provide brokerage services for them. Being the second biosolids compost available in the area, the LCRA should develop a distribution system which meets the needs of the landscape/nursery industry, taking heed of the sometimes negative comments regarding the Dillo Dirt program. Since the LCRA product would likely be compared to Dillo Dirt before either a cotton burr or manure based product, it must possess as good or superior a quality and it must be consistent in nature. Also, resources must be expended to develop name recognition for the product since the Dillo Dirt name is well established.

5.2 - BULKING AGENT SOURCES FOR COMPOSTING

Preliminary investigation was completed in order to identify potential sources of bulking agent for composting. Bulking agent is used to improve the porosity and physical structure of the compost mix to allow aeration throughout the piles. The bulking agent will also act as a source of carbon, which is necessary for a proper ratio with nitrogen for composting. The LCRA biosolids will provide the nitrogen to the process. Typical bulking agents used in biosolids composting are wood chips, bark, sawdust, ground demolition/pallet wood, and ground yard trimmings.

The goal of this preliminary investigation was to identify potential sources, volumes available, and costs for locally produced bulking agents. This is imperative since a significant cost of operating a composting facility can be attributed to the purchase of bulking agents.

5.2.1 Bulking Agent Requirements

The quantity of bulking agent required to compost a particular biosolids product is based primarily on the quantity of biosolids to be processed. The volume of bulking agent needed is primarily influenced by the volume of biosolids and the moisture content of the biosolids. It is also influenced by the moisture content of the bulking agent. It also depends upon the type of bulking agent (e.g. wood chips, sawdust, ground pallets), its texture/particle size, and purity.

The quantity required on an annual basis will also depend on if screening of the final product is practiced. The more bulking agent that is screened out of the product and recovered for re-use, the less new bulking agent is necessary. Usually, the biosolids are blended with both new (virgin) and recovered (recycled) bulking agent. Reusing the bulking agent is of economic benefit, since it reduces the quantity of new bulking agent required. Based on an initial biosolids production rate of ten dry tons per day (on a five day/week basis) and a 50% bulking agent recovery rate through screening, preliminary calculations estimate that approximately 26,000 cubic yards of bulking agent (yard debris or chipped tree trimmings) will be required annually for a LCRA composting facility.

5.2.2 Local Bulking Agent Availability

Unlike eastern Texas, central Texas does not possess a wood (silviculture) industry. Therefore, sawdust, bark, and wood chips are not available locally at an economic cost. Because of this fact, yard debris, tree trimmings, and ground pallet wood will be a more viable bulking agent to use. In this preliminary research, only yard debris and tree trimmings were investigated because they are more likely to be obtained at no cost to the LCRA. Potential sources identified can be found in Table 5-5.

**TABLE 5-5
POTENTIAL BULKING AGENT SOURCES¹**

Company/Utility	Type	Bulking Agent	Volume Generated or Collected/Year	Other
City of Austin (Phil Tamez)	City Dept.	yard debris/ brush, chipped line clearing wood ²	20-30,000 yd ³ 50,000 yd ³	use all of material they generate at their Hornsby Bend composting facility - none is available
Asplundh Tree Service (Dan Stahl)	Arborist	chipped tree wood from tree pruning and line clearing	1-2,000 yd ³	source is obtainable, probably generate more than stated volume
Del Webb Sun City Georgetown (Larry Michaels)	Developer	chipped tree wood	unknown	have an estimated 10,000 cubic yards stockpiled currently, chipping trees after land clearing for development of 15 year long project.
City of Georgetown (Hartley Sappington)	City Dept.	yard debris/brush	4-6,000 yd ³	source is obtainable, could double volume by selectively picking up brush during monthly collection of bulking wastes. Believes obtaining source separated yard debris is possible but must negotiate with haulers and change city ordinances
LCRA (Jesse Warren)	Public Utility	chipped line clearing wood ²	Unknown	very little generated, chipped material left at site, brought to dump or to Hornsby Bend composting facility
City of Round Rock (Larry Matson)	City Dept.	yard debris	10-12,000 yd ³	grind material from drop off areas twice a year, give-away most of it and use some once ground. Are interested in having someone take it before in unground.

**TABLE 5-5
POTENTIAL BULKING AGENT SOURCES
Continued**

Company/Utility	Type	Bulking Agent	Volume Generated or Collected/Year	Other
Texas Utilities (Jeff Tweed)	Public Utility	chipped line clearing wood ²	4-8,000 yd ³	currently chip and give-away, interested in a no cost disposal option, supplying convenient dump/pick-up location is critical to obtaining supply
Waste Mgmt. Inc. (Sonny San Filippi)	Private Corp.	yard debris	50-60,000 yd ³	operates Austin Community Landfill (ACL) and Williamson County Landfill (WCL), ACL obtains 50-60,000 of yard debris/yr., but it is mixed with garbage, would like to explore ways to provide LCRA with clean bulking agent. WCL obtains minimal yard debris

Notes: ¹BFI Landfill and Texas Disposal Services Landfills obtain yard debris, but availability to LCRA is unknown at this point
²Chipped line clearing wood - removal of tree limbs from around high voltage electrical lines, on-going maintenance practice
³Information obtained from Hartley Sappington, City of Georgetown - unable to speak with Larry Michaels directly

In order to identify potential sources of yard debris and tree trimmings, several local landfills, cities, and electric utilities were contacted. Currently, the only local city which collects source separated yard debris on an on-going basis is Austin. The city of Austin's Hornsby Bend biosolids composting facility uses all of the city generated yard debris, estimated at 20-30,000 cubic yards per year. It also uses approximately 50,000 cubic yards of wood chips, which they obtain from their local electric utility. Tree branches are removed from high voltage line areas during on-going line clearing practices. Although Austin's yard debris is not available, yard debris from the cities of Round Rock and Georgetown may be. Between 14,000 and 18,000 cubic yards is generated annually at community drop off sites in these two cities. Representatives from the city of Georgetown felt the volume of collected yard debris could double if a guaranteed user is identified. Both communities felt that the ability to stockpile the material at a convenient

location for them would be imperative to consummating an agreement in this area. Therefore the LCRA would likely be responsible for transporting the yard debris to their composting site. Neither city is currently paying to have their chips removed, but they often deliver chips locally. That is why a convenient stockpile location would be an economic incentive for the cities.

Several landfills in the area obtain yard debris, but the majority of it is commingled with garbage. However, source separated yard debris and tree trimmings are sometime received at local landfills from commercial landscapers and tree companies. Most landfills charge tipping fees to receive yard debris which is periodically chipped and stockpiled for use as daily cover or resold to the public. The Austin Community Landfill, operated by Waste Management, Inc. (WMI), receives 50-60,000 cubic yards of yard debris annually, but it is contaminated with garbage to some extent. Their manager, however, is interested in discussing the possibility of reducing the tip fee to obtain clean yard debris, as long as they have someone who will pick it up at the landfill and remove it. The Williamson County Landfill, also operated by WMI, does not receive much yard debris due to its rural location and because burning of yard debris is allowed. However, large volumes of wood chips are received at this landfill from time to time. Currently, 15,000 cubic yards of wood chips are stockpiled at the Williamson County Facility.

Companies which maintain high voltage power lines generate large volumes of tree trimmings which they chip. Similar to local cities, they do not typically pay to dispose of these chips. They attempt to locate individuals near the point of generation who take the chips free of charge. However, this is not always convenient. For this reason Texas Utilities and Asplundh Tree Service are interested in finding an on-going disposal option which is more convenient. Both are willing to supply the LCRA with wood chips if convenient stockpiling locations are identified. The LCRA would be required to pick-up these wood chips if the composting site was not conveniently located.

Large potential sources of free bulking agent, yard debris, and chipped tree trimmings are available locally if the LCRA is willing to manage transportation of the materials. Several sources of uncontaminated yard debris are available from local cities and companies maintaining high voltage lines. Uncontaminated sources of wood chips also appear to be available from a

large community development company (Del Webb). Local landfills may also be able to supply large quantities of yard debris if methods can be developed to reduce or eliminate contamination.

5.3 - POTENTIAL LAND RESOURCES FOR LAND APPLICATION/COMPOSTING

To locate and identify areas suitable for the land application scenarios, E&A developed several criteria to define the boundaries of an initial "study area". These criteria required that the area be:

- Located east of Interstate Highway (IH) 35
- Located no further than 40-50 miles from each of the participating communities
- Within 5 miles of a U.S. or State highway
- Located in an agricultural area currently being farmed, or have soils capable of growing crops
- Located in an area not currently experiencing (and not likely to experience in the near future) urban/suburban development

From these criteria, EH&A selected a study area east of Georgetown and Round Rock, in southern Williamson County, and a study area east of Pflugerville in northern Travis County. In central Texas IH-35 roughly divides the two major physiographic/ecological zones of the region: the Edwards Plateau and the Blackland Prairie. The Edwards Plateau is characterized by hill and canyon topography, thin soils, and limestone bedrock (often exposed at the surface). Agricultural uses of the "hill country" are primarily restricted to ranching. The Blackland Prairie, on the other hand, consists of a broad belt of relatively deep, fertile, clay-rich soils that support a strong farming economy. Locating the study area east of IH-35 also largely avoids potential environmental constraints associated with endangered species and the Edwards Aquifer Recharge Zone, which are primarily confined to the area west of the Interstate.

The northern study area selected by EH&A is adjacent to two of the largest participating communities, Georgetown and Round Rock, and is within 40 miles of the rest of the participants. The area is bounded by State Highway (SH) 29 on the north, U.S. Highway 79 on the south, IH-35 on the west, and SH 96 on the east (see Figure entitled Study Area 1). The southern study area (Figure entitled Study Area 2) is also near the participants, although not as close to the largest sludge generators. This area is bounded by the Travis County limits on the north and on the east;

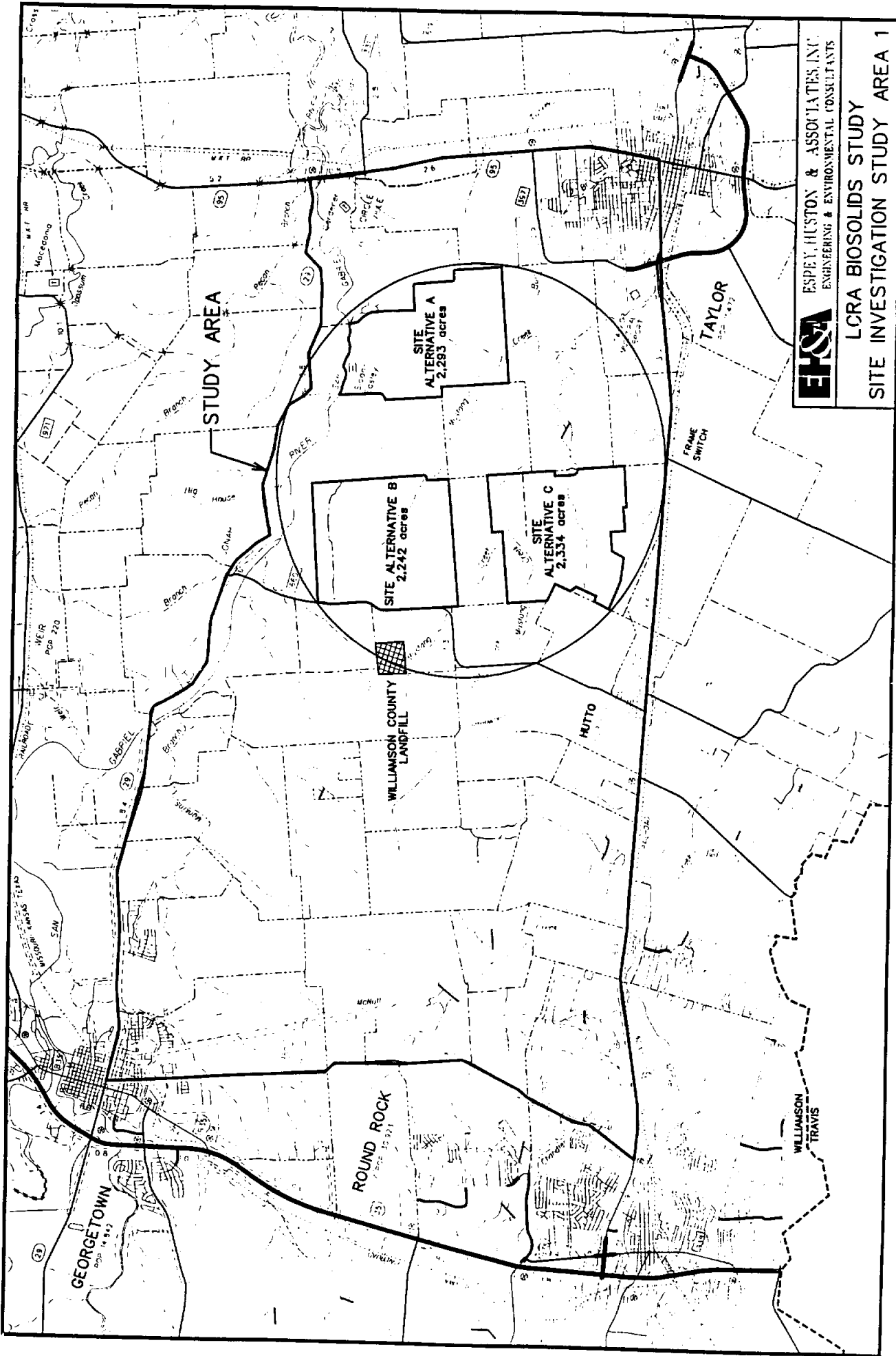

EHS&A ESPEY, HUSTON & ASSOCIATES, INC.
ENGINEERING & ENVIRONMENTAL CONSULTANTS

LCRA BIOSOLIDS STUDY
SITE INVESTIGATION STUDY AREA 1

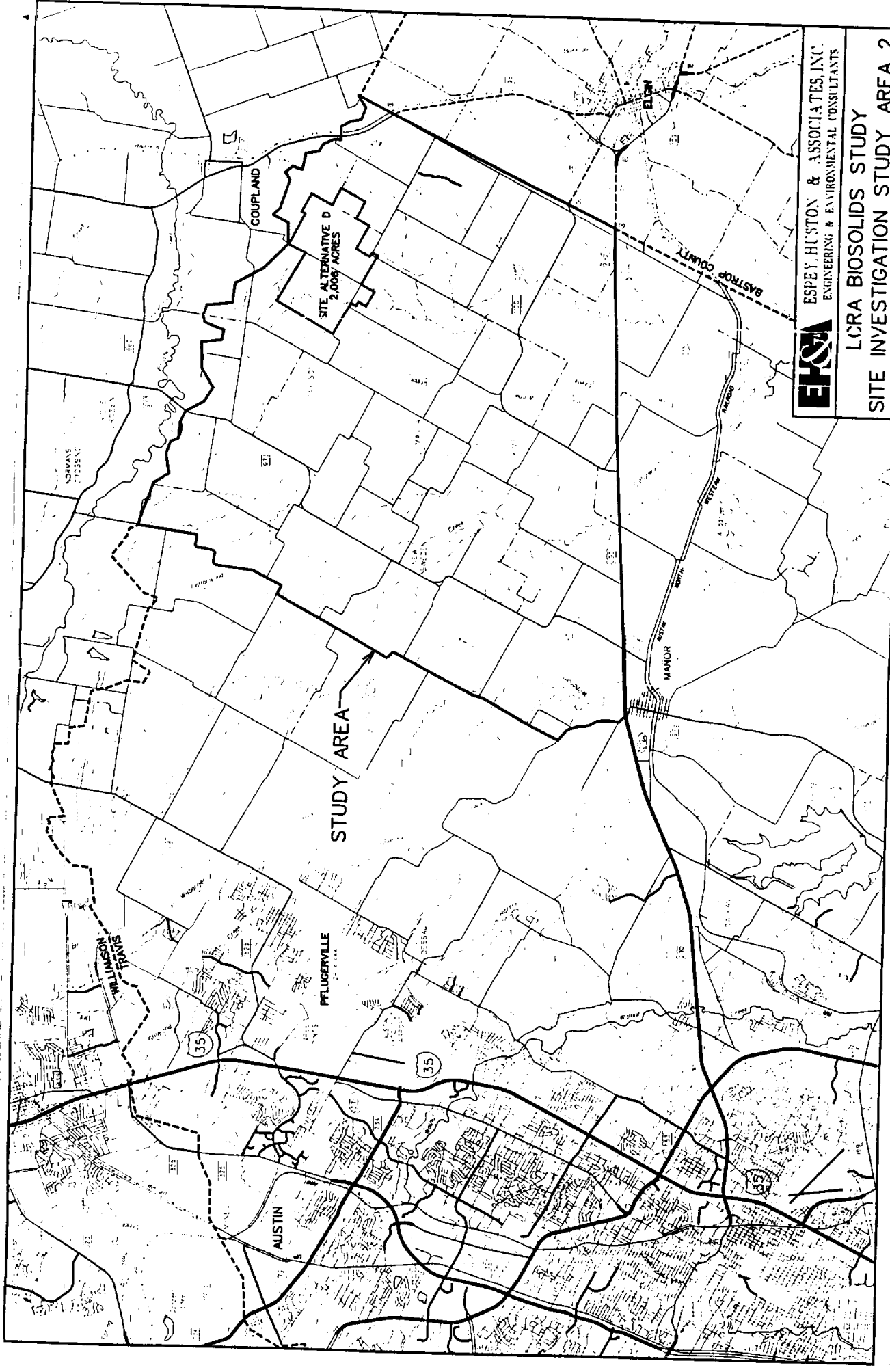

ELSA
 ESPEY, HUSTON & ASSOCIATES, INC.
 ENGINEERING & ENVIRONMENTAL CONSULTANTS

LCRA BIOSOLIDS STUDY
SITE INVESTIGATION STUDY AREA 2

U.S. Highway 290 on the south; and Fuchs Grove Road, Cameron Road, and Engerman Lane on the west.

5.3.1 - Land Requirements

Land area requirements were determined for six different biosolids composting/land application scenarios. These scenarios include land application only for current biosolids production rates and for the year 2005 biosolids production rates. Composting only is an alternative studied for both current and the year 2005 biosolids production rates. Also, two combinations of land application and composting were investigated. The resulting minimum acreage required for each of the six scenarios ranged from 14 to 1,140 acres.

Buffer zones from roadways, environmental features, and inhabited areas will be required on all sides of the selected land application/composting areas. Because the specific site has not been determined, a large area will be designated as buffer in the planning stage. Therefore, for each scenario, the required acreage was increased by 100% for potential buffering purposes. Therefore, the land area requirement for each composting/land application scenario ranges from 28 to 2,280 acres. The investigation for facility location alternatives surveyed sites meeting the larger acreage requirement, in which smaller acreage could be selected if warranted.

5.3.2 - Land Related Issues

The southern Williamson County and northern Travis County areas east of Interstate 35 are largely under agricultural use. The majority of the population live in suburbs that are clustered around the major cities along Interstate 35 and intersecting U.S. highways. Williamson County was settled in the early 19th century, and it was organized into a county in 1848. Many of the original farming family descendants still live and farm the land.

According to Williamson County Agricultural Extension Agent Lee Garrett, between 50,000 and 60,000 acres of the county are planted in cotton, approximately 45,000 acres are planted in corn, 50,000 acres are planted in sorghum, and 30,000 acres are planted in oats and wheat. He also indicated that Williamson County is a traditional Texas county with families

farming the same piece of land for over 150 years, yet they are very open minded to new and cost effective farming techniques and operations.

Both the northern and southern study areas consist of level to rolling Blackland prairie. Southeastern Williamson County is drained by the San Gabriel River and its tributaries while northeastern Travis County is drained by Willow Creek discharging to the Colorado River. An average rainfall of 34.2 inches, a growing season of 258 days, and the fertile quality of the soil combine to make agribusiness the primary economy in these portions of the county. Cash crops such as sorghum, corn, cotton, and wheat are grown throughout the study areas and account for approximately 90% of the land use.

5.3.3 - Available Land

Two areas were selected in southeastern Williamson County and northeastern Travis County that met all of the established land application criteria. A first-hand knowledge of the area greatly facilitated the site alternative selection, and aided in the collection of information about the area. The study area's proximity to Austin allowed for a brief field check of the site alternatives. Telephone conversations with realtors in the area indicated that prime agricultural land sells for \$1,000 to \$2,000 an acre in eastern Travis and Williamson Counties.

Using land ownership and tax plat maps from the Williamson and Travis County Appraisal Districts, an area relatively free of development (i.e.: subdivisions, schools, and churches, etc.) was selected in the eastern portion of the study area for placement of the site alternatives. The areas selected are sparsely populated, and the majority of the population live in isolated farm houses. The study area is planted in corn, sorghum, cotton and, to a minor degree, hay. Numerous small county roads bisect the area, and a few intermittent drainages cross the study area.

The land in both the southeastern portion of Williamson County and the northeastern portion of Travis County is divided into relatively small tracts of 100 acres or less. However, there are a few large tracts in excess of 400 acres within the study areas. An attempt was made to locate the alternatives on the largest tracts of land possible, and away from the more populated

areas. To be able to locate approximately 2,000 acres, many separate small tracts were combined into the site alternatives.

Site A is the northeastern-most alternative, and it is the second farthest alternative from the participating municipalities. The terrain of Site A is more rolling and more rugged than the other alternatives, as well as having more homes and being more populated. Site A is 2,293 acres and it has 19 land owners. This site is adjacent to and northwest of the City of Taylor (population 11,472). Site A borders the San Gabriel River on the north, and the land generally slopes down to the north toward the river. An established gravel quarry is located at the northeast end of Alternative A, and a cemetery is located on a north facing slope overlooking the San Gabriel River. The land is primarily planted in corn with a few fields being planted in cotton.

Site B is the most level of the alternatives, and it has fewer houses than the other three alternatives. Site B is 2,242 acres and it has 14 land owners. It is primarily planted in cotton with a few fields being planted in corn, sorghum, and hay. Paved county roads almost totally surround this alternative, and an improved Farm-to-Market road (FM 1660) borders the site along the west. The Williamson County Landfill is adjacent to and west of this alternative.

Site C has more homes and a denser population than the other alternatives. It is 2,334 acres and it has 22 land owners. Site C is located near the community of Hutto (population 630). Two sections of an intermittent stream, Mustang Creek, dissect this alternative, and a catfish farm is adjacent to and down stream of this site. An improved county road cuts part way through this alternative near the northern edge and leads to a couple of homes in the middle of Site C. This alternative has more land planted in hay than the other alternatives, and there is about an equal mix of corn and cotton planted within this alternative.

Site D is located near Coupland, northeast of Manor. It is 2,006 acres and has fourteen land owners. Nearly all of the land is planted in a variety of crops, and there are a minimal number of houses in this area. Both Little Willow and Willow Creeks run through the site, although the land remains relatively level over the entire area. This alternative is fairly accessible, since State Highway 95 runs very near to the site and all the roads in the region are paved.

Site Alternatives A through C are located within 40 miles of the participating municipalities, and all are less than 5 miles from a U.S. or State Highway. The land is prime agricultural farmland supporting cash crops. The alternatives are located outside of areas of potential urban/suburban development. However, Alternatives A and C are in close proximity to small communities which could potentially develop in the directions of the site alternatives, yet property ownership suggests that suburban development will occur south and west of U.S. Highway 79 near Taylor and west of the community of Hutto near Round Rock.

Site Alternative B is considered to be the preferred alternative because of its ease of access, the level terrain, the sparse population, and its proximity to the Williamson County Landfill. Site Alternative A is considered as the second choice because of its sparse population, yet it has an established industry, the gravel quarry, in the northeastern section, and it also slopes down to the north and drains into the San Gabriel River. Site Alternative D is farther away from the participants, approximately 8 miles southeast of the alternatives A, B and C. Site Alternative C would be considered less desirable than site alternative A or B because of the denser population and its proximity to the community of Hutto. Site Alternative D is in the proximity of the community of Coupland.

6.0 - PRELIMINARY DESIGN

This chapter provides a description of the rationale used in selecting land application and composting alternatives for detailed cost analysis in Chapter 7.

6.1 - ALTERNATIVES SECTION

Selection of alternatives for further evaluation is based on numerous factors including, but not limited to:

- Biosolids quantity
- Biosolids metal quality
- Biosolids solids content
- Technology suitability
- Technology track record
- Owner preference

Table 2-1 summarizes the estimated quantity of biosolids generated at each of the 12 facilities in 1995. Two of the main issues influencing how much biosolids will be available for a joint program include which communities will participate and when the program will be implemented. Overall biosolids generation is expected to double by the year 2005. Due to the fact that several entities could be involved, it is likely that at least one to three years will pass prior to any program implementation. This time period will likely result in biosolids quantities 20% to 30% more than shown in Table 2-1.

Table 2-3 summarizes the results of a one-time biosolids sampling in June 1996 for metal concentration as well as several other parameters. Biosolids from all facilities meet metal concentration limits of the U.S. EPA 503 requirements for Class A. Based on this factor, all materials could be considered for land application or composting.

Biosolids total solids content is another factor which must be considered. Land application of both liquid and cake can be performed. However, an initial investigation into land application of those entities which generate only liquid biosolids found their costs to be significantly higher than other options due to the large amount of water which would be transported. Composting should only be practiced with dewatered biosolids in order for economics to be acceptable. Since many of the plants dewater their biosolids either mechanically (belt filter press) or physically (sand drying beds), biosolids cake from these operations is suitable

for composting. Biosolids from Anderson Mill MUD, Lost Creek MUD, and half of Brushy Creek MUD's production are only thickened and, therefore, require further dewatering. At a review meeting for the project, it was agreed by all parties that dewatering of liquid biosolids from these three plants should be practiced. Dewatering could be performed periodically on-site using mobile equipment, or liquid biosolids could be transported to another wastewater plant for dewatering.

Technology suitability should be matched to the characteristics of the biosolids and also take into account previous performance (track record), cost, and owner preference. For land application, only application of cake appears economically feasible. For composting, site specific characteristics can play a big role in selecting the technology. Windrow or aerated windrow take the most land, are the most prone to weather impacts, and also have the greatest odor potential. Aerated static pile can be accomplished uncovered, covered, or totally enclosed depending on the level of odor control required. Agitated bed is typically best suited for larger quantities, has a high degree of process control, but has the highest cost. Based on these factors, and the fact that a site has not been chosen for consideration, a mid-range composting technology is appropriate for consideration. Therefore, covered aerated static pile with partial odor control of the process offgas will be considered in the design basis. Land application of the entire biosolids quantity in a cake form will be considered. In order to develop a range of costs for composting for which costs are more size dependent, a base case quantity of 1,950 dry tons per year or 7.5 dry tons per operating day (5 day/week basis) and a future capacity of 3,900 dry tons annually or 15 dry tons per day will be considered. These quantities equate to roughly 75% of the existing cake quantity in the base case and 150% in the future case.

The alternatives, then, which will be evaluated are as follows:

Alternative 1

Land apply 2,830 dry tons per year as cake

Alternative 2

Compost 1,950 dry tons per year as cake (base case)

Compost 3,900 dry tons per year as cake (future case)

6.2 - LAND APPLICATION DESIGN CRITERIA

6.2.1 - Biosolids Processing Capacity

The following section contains estimates for acreage needed to apply biosolids generated by the participating entities. The estimates assume that the biosolids contain an average of 5.6% organic nitrogen and 0.3% inorganic nitrogen. The calculations also assume that the metals levels of the biosolids will not limit the application and that pathogen reduction and vector attraction reduction requirements have been achieved.

Land application acreage needs have been calculated for one scenario. The total dry tons generated from all of the communities represent the quantity to be applied. Several communities have biosolids with low percent solids content. Biosolids from all participating entities are assumed to be managed at plants with dewatering capabilities or dewatered on-site. Therefore, this analysis assumes all dry solids will be dewatered and land applied. Table 6-1 below shows the dry tons generated per year.

TABLE 6-1
ANNUAL DRY TONS GENERATED

SCENARIO	ANNUAL DRY TON PRODUCTION
All Communities	2,830

As shown in Section 4, the calculation of agronomic loading rate at 200 lb/acre is approximately seven dry tons per acre (for first year of application at site) for these biosolids. Estimates for acreage needed to apply all the materials for the two alternatives is shown below. If land application is chosen as a reuse method, additional information will be gathered concerning application site background information, application method, crop rotations, fertilizing practices, and more. For the purposes of this estimate, it is assumed that twice the required area will be needed to account for buffers and crop rotation. This estimate assumes that

immediate incorporation into the soil will be practiced which means no losses to the atmosphere through volatilization. Losses to the atmosphere would translate to a higher application rate. In addition, a mineralization rate of 20% has been assumed for the calculation of available organic nitrogen. Table 6-2 below shows the acreage needed for application to a variety of crops.

TABLE 6-2¹
ACREAGE NEEDED FOR APPLICATION OF BIOSOLIDS W/28.4 LB. AVAILABLE NITROGEN/DRY TON

Crop	Lb/Acre Nitrogen Needed	Dry tons/Acre	Estimated Acres Needed	
			2,830 dt/yr	5 yr. total
Cottonseed	62	2.2	1,297	1,843
Grain sorghum	80	2.8	1,005	1,467
Wheat	125	4.4	643	939
Oats	150	5.3	536	782
Corn	200	7.0	402	587
Orchard grass	300	10.5	268	391
Alfalfa hay	330	11.6	244	356

¹No buffers included

These estimates do not include any residual nitrogen in the soil at the chosen site, which can reduce slightly the application rate. In addition, the estimate above is for the first year of application at a site and the fifth year of application. Organic nitrogen is released slowly over the course of approximately five years when concurrent applications occur for several years on the same site. This release will need to be accounted for in subsequent calculations for application to a site. After five years, the biosolids nitrogen is considered part of stable soil organic matter and is included in calculations of background levels of nitrogen. Table 6-3 shows the residual organic nitrogen available in the soil for five years after application and the acres required for application of the biosolids each year.

TABLE 6-3
RESIDUAL NITROGEN DUE TO PREVIOUS APPLICATION

% Inorganic Nitrogen	% Organic Nitrogen	Mineralization rate	Lb. Nitrogen/dt as Applied 1	Subsequent Years Available Nitrogen Lb N/Dry Ton for Years				
				2	3	4	5	
0.3%	5.6%	20%	28.4	8.8	3.3	1.1	1.1	
Acres needed to apply 200 lb nitrogen/acre								
			Alternative 1	402	497	545	569	587
			1A ¹	804	994	1,090	1,138	1,174

¹ Accounts for buffer and crop rotation needs

6.2.2 - General Design Criteria

This section of the report defines several facility design criteria which are used in subsequent cost analyses for the two land application alternatives evaluated.

6.2.2.1 - Material Transport

Materials will need to be transported to the land application site via transport truck. Dewatered materials can be transported with an end dump tractor trailer, off-loaded at the site, and transferred to the manure spreader with a front end loader. In general, these end dump type trucks are required to have a tarp on top to help prevent unwanted discharge during transport.

6.2.2.2 - Material Storage

The storage of materials at a site is allowed for up to 90 days. As seen in Table 6-4, the cropping schedule in the area typically has a maximum of a three month period where both summer and winter crops are on the fields. During this period, the biosolids materials must be stored. This storage may be necessary to accommodate inclement weather or crop harvest. The storage area is required to be equipped with a liner and must catch all runoff from the area. The liner must have a permeability of 1×10^{-7} cm/sec or less. For inclusion of all biosolids generated

by the participating entities, an area of approximately one half acre would be sufficient for the storage of 90 days generation rate of dewatered biosolids. Written authorization must be obtained from the executive director of the TNRCC prior to construction of any storage area.

**TABLE 6-4
TYPICAL CROP ROTATIONS AND WET MONTH RAINFALL
IN THE TRAVIS AND WILLIAMSON COUNTY AREAS**

Crop	Jan	Feb	Mar	Apr	May	Jun	Jul	Aug	Sep	Oct	Nov	Dec
	Inches of rain for wet months											
				2.6	4.8	3.7			3.3	3.4		
Cottonseed - s			h	h	h	h	h	h				
Grain sorghum - s			h	h	h	h	h	h				
Wheat - w	p	p			h				h	h	h	h
Oats - w	p	p			h				h	h	h	h
Corn - s			h	h	h	h	h	h				
Coast berm. grass - s			h	h	h	h	h	h				

p - plant
h - harvest
s - summer crop
w - winter crop

55,000 acres cultivated in the County
80% summer crops
20% winter crops

32 inches of rainfall annually

Open blocks are time periods available for land application of biosolids

6.2.2.3 - Operating Schedules

Schedules for operating the application site will be eight hours per day, five days per week, 52 weeks per year, weather permitting. It is assumed that the operation of the site will be conducted by LCRA personnel. If this is not desirable, the site can be operated by a contractor. Many such contractors operate throughout the Country, and a request for proposals process will yield many responses.

Application of 50 wet tons of biosolids per day on average will require two trips per day to the site. Each trip is assumed to require approximately one hour. The dewatered biosolids which are surface applied will also need to be tilled in under the surface of the soil. This will take an additional hour per day. The total application time including equipment transfer (the same tractor is used to pull both pieces of equipment) is approximately 6 hours. Additional time will be required for record keeping (daily) and sampling/monitoring (intermittent basis).

6.2.2.4 - Site Condition Assumptions

Because no site has been chosen, the following assumptions have been made for the facility. These include:

- Suitable road access is available to the site, up to within 1,000 feet of the application field
- No unusual site conditions are included and it is assumed that there is little surface water on or near the site
- The water table is at a suitable distance from the surface of the soil
- Crops will be grown on the site in order to establish beneficial reuse of the biosolids
- Biosolids will be applied at agronomic loading rates which will match the nitrogen uptake of the crops grown

Biosolids from the participating entities will likely need to be mixed at the site. This can occur at the storage area. The EPA views mixing and blending biosolids at a regional facility as a viable method of beneficial use. This activity can be accomplished with the front end loader at the site. The blended materials must be tested prior to application in order to assure compliance with the appropriate regulatory requirements.

6.2.2.5 - Applying

Application at the site must be accomplished in a manner which ensures that agronomic loading for the chosen crop is not exceeded. This rate is defined for each plot of land depending on the crop to be grown, the previous biosolids application, and the naturally occurring background levels of available nitrogen. Taking each of these factors into account, an application rate will be determined for each plot of land. The application rate will be defined by solids content of the material, most recent nutrient analysis, and speed of discharge of the spreader.

For a rate of seven dry tons per acre at 20% solids, this equates to approximately 39 cubic yards per acre or 0.3 inches across the entire acre. Application in a blanket layer is not possible for dewatered biosolids, so the known cubic yardage of the spreader will need to be applied evenly over a known square foot area. The chosen spreader is a 27 cubic yard model, so a full load will need to be spread evenly over seven tenths of an acre.

6.3 - COMPOSTING DESIGN CRITERIA

This section of the report defines several facility design criteria which are used in subsequent cost analyses for the two composting scenarios evaluated.

6.3.1 - Biosolids Processing Capacity

Table 2-1 shows the annual biosolids production data for the participating entities in the feasibility study. Daily biosolids production on a five day per week basis ranges from a low of less than 0.1 for Manor to 5.6 dry tons per day for the City of Round Rock (both East and West facilities). A total biosolids production rate for all entities involved in the analysis is 7.75 dry tons per day on a five day per week basis. These values are based on 1995 annual production records.

Based on the alternatives selection discussion, the following two biosolids processing capacity systems will be evaluated:

- 7.5 dry tons per day of biosolids on a five day per week basis (1,950 dry tons per year)
- 15 dry tons per day of biosolids on a five day per week basis (3,900 dry tons per year)

Cost analysis of these two sized facilities will provide a range that could be expected for both present and future biosolids quantities.

The single most critical factor in terms of facility size and economics on a dry ton per day capacity is cake solids concentration of the biosolids. As Table 2-3 indicates, cake solids concentration ranges from 14% to 60% for the 10 facilities which dewater by belt filter press or sand drying beds. On a weighted basis, the average solids content is 27% TS. However, due to limited analytical data and the fact that winter time drying bed performance will be poorer, an overall average of 20% TS is being used as a basis for design. This assumption provides a

level of conservancy in the design of the composting facility. However, if results of additional sampling data indicate a dryer cake solids can continue to be achieved, less materials handling and small facilities will be required. This will result in an overall lower unit cost for biosolids composting.

6.3.2 - General Composting Design Criteria

This section of the report addresses ancillary issues outside of the main processing areas within the composting facility.

6.3.2.1 - Materials Transport

The materials which would be transported to a composting facility include dewatered biosolids and clean processed yard wastes. Other potential materials which can be accommodated at the facility are woodchips. Transporting of these materials to the composting facility will be the responsibility of LCRA or the participating entities (i.e., LCRA or the participating entities must provide personnel and equipment to haul biosolids, yard waste, and other waste materials for delivery to the composting facility during normal operating hours). Vehicles which can be accommodated at the facility must be self-tipping, such as dump trucks, live-bottom trailers, or other means for dumping loads onto storage pads.

6.3.2.2 - Materials Delivery, Receiving, and Storage

Materials delivery to the composting facilities will be accommodated on an eight hour per day basis, five days per week on a Monday through Friday schedule. Exact hours of operation can be determined at a later date. However, from the standpoint of conceptually sizing the facilities, an eight hour work day has been assumed. It is assumed that a set of weigh scales will be provided to determine weights of materials received and removed from the composting facility. Biosolids receiving will be in a paved, covered building, adjacent to the mixing system. A series of concrete bunkers will be used for participating entities to deposit their loads of biosolids. Space has been provided in the facilities to allow for storage of up to half a days

biosolids production on average. Yard waste storage is assumed to occur on an open asphalt storage pad with capacity to manage up to 30 days worth of ground yard waste or woodchips.

6.3.2.3 - Operating Schedules

The receiving of yard waste and biosolids is currently envisioned to occur on a five day per week basis, eight hours per day, for a total of 40 hours. In addition to this base operating schedule, it has been assumed that the facility will be manned and open for eight hours on Saturdays to receive yard wastes and to load compost customers. Processing of biosolids is anticipated to occur on a five day per week basis, approximately 6½ hours per day, for a total of 32.5 operating hours per week. Processing equipment has been sized to process the daily average quantity of biosolids times a peaking factor of 1.5 or 150%.

6.3.2.4 - Site Condition Assumptions

Because no site has been established for a regional composting facility, a number of assumptions have been included to allow for a generic site. They include the following:

- On-site utilities such as water and electric are assumed to be hooked up within 1,000 feet of the main compost processing building.
- Condensate/leachate retention pond with ability to pump and haul to a wastewater facility.
- Suitable road access is available to the site (i.e. excessive road access improvements have not been provided for except for 1,000 feet of roadway entry).
- No unusual site conditions are included. It is assumed the composting site will be fairly level, contain good soil which will not require extensive earthwork to accommodate building loads, and the water table is at least five feet below the surface so no unusual drainage problems are involved.
- Composting and storage areas are assumed to be set back a minimum of approximately 500 feet from the facility perimeter in order to estimate facility sizing/acreage requirements and provide for a buffer.
- Fencing for site security around the immediate processing areas of the facility, including a locking entry gate is included in the cost estimate.

6.3.2.5 - Odor Control Technology

Biofiltration will be the technology used to treat odorous air from the composting process. It is recognized through previous facility operations that the vast majority of odors generated at

composting facilities is attributable to the active high rate composting process itself. For this reason, both composting facilities are based on a covered receiving, mixing, and composting building with compost process exhaust gases being treated through a biofiltration system. Curing, screening, and material storage areas are in combinations of covered or open storage pad areas.

6.3.3 - Aerated Static Pile Composting Facility

Figure 6-1 shows the process flow diagram associated with the aerated static pile technology. A description of the process follows.

6.3.3.1 - Biosolids Receiving

Biosolids from the participating entities will be trucked to the composting facility. Vehicles containing biosolids will be weighed and then directed to the receiving area under roof where loads of biosolids will be dumped into receiving bunkers.

6.3.3.2 - Yard Waste Receiving/Processing

Clean ground yard wastes will be trucked to the regional composting facility by LCRA or the participating entities or other suppliers and weighed at the composting facility. Grinding equipment/facilities are not included. It is assumed that participating entities can supply clean, chipped yard wastes using their own equipment or through a mobile equipment contractor. Further analysis and planning is required in the preliminary design stage to refine this concept. After weighing, vehicles will be directed to an open storage pad where the materials will be inspected and dumped for storage. Approximately 30 days of ground yard waste wood chips storage capacity is provided for at the facility. A covered storage area will be provided to allow storage of a one week supply of new bulking agent. In addition to being covered, this area will have concrete pushwalls and can accommodate any type of bulking agent which needs to be kept dry. The ground yard waste/wood chips storage area is assumed to be an open pad which will allow stacking of ground bulking agent in a 12-foot high pile and stored for a period of 30

FIGURE 6-1 AERATED STATIC PILE PROCESS FLOW DIAGRAM

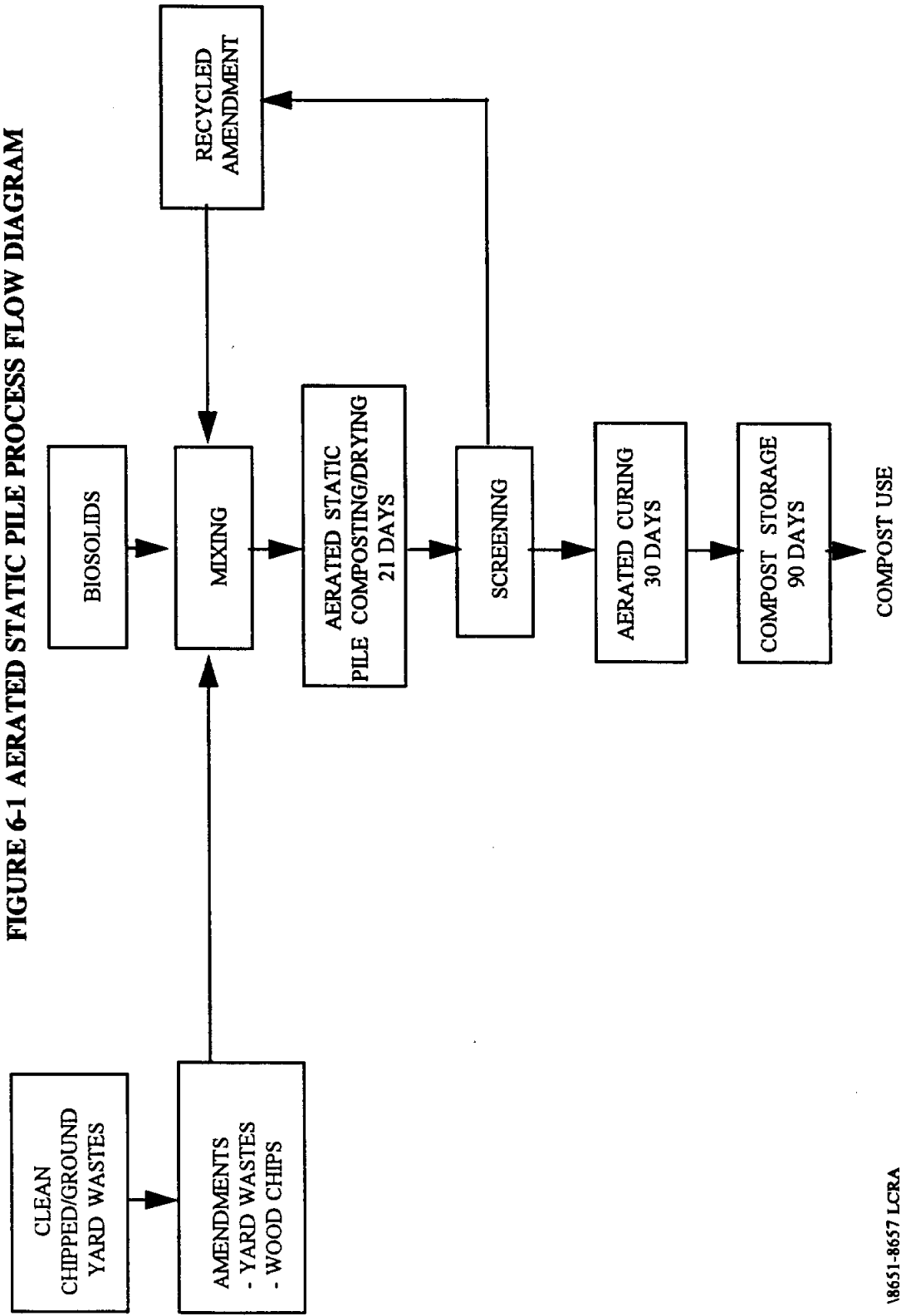

calendar days or 22 operating days. Provision has also been provided for an open storage pad for recycled bulking agent up to 15 calendar days or 11 operating days.

6.3.3.3 - Mixing

Ground yard wastes, recycled amendment, and any other materials to be used as bulking agent will be placed into a batch mixing box for processing. The batch mixer has a capacity of 18 cubic yards and is outfitted with weigh scales such that precise quantities of amendment and biosolids can be measured, and subsequently, mixed. Two batch mixers will be provided for in the 7.5 dry ton per day facility and three in the 15 dry ton per day facility to allow for redundancy. These mix boxes, after being loaded with appropriate quantity of biosolids and bulking agent, will mix the contents in a period of about five to ten minutes and then discharge the contents into a surge pile in a three-sided concrete bunker. Front-end loaders will be used to load the material into the mix boxes, and also to pick up mixed material and place it into the aerated static pile. The batch mixers will be permanently mounted and electrically driven. These facilities will be located under cover .

6.3.3.4 - Composting

The aerated static pile composting and drying process will occur in a covered, open-sided pre-engineered building that has concrete flooring and pre-cast trenches to provide aeration. The area will be sized to provide 21 calendar days worth of composting and drying , and also to allow access for pile construction and teardown activities. The process flow in the aerated static pile area includes the placement of a base of wood chips on which an eight-foot layer of initial mix of biosolids and bulking agent will be placed, and a one-foot cover of finished compost as an insulation layer. The extended pile configuration, as shown in Figures 6-2 and 6-3 will be used in the aerated static pile portion of the process. Multiple blower stations will be provided to allow for maximum control and the capability of running in either a downdraft, negative aeration mode or an updraft, positive aeration mode. Process offgases from the aeration blowers will be collected and treated through an open biofiltration treatment system. The aerated static pile blower system will be controlled by a computer control system that has temperature feedback

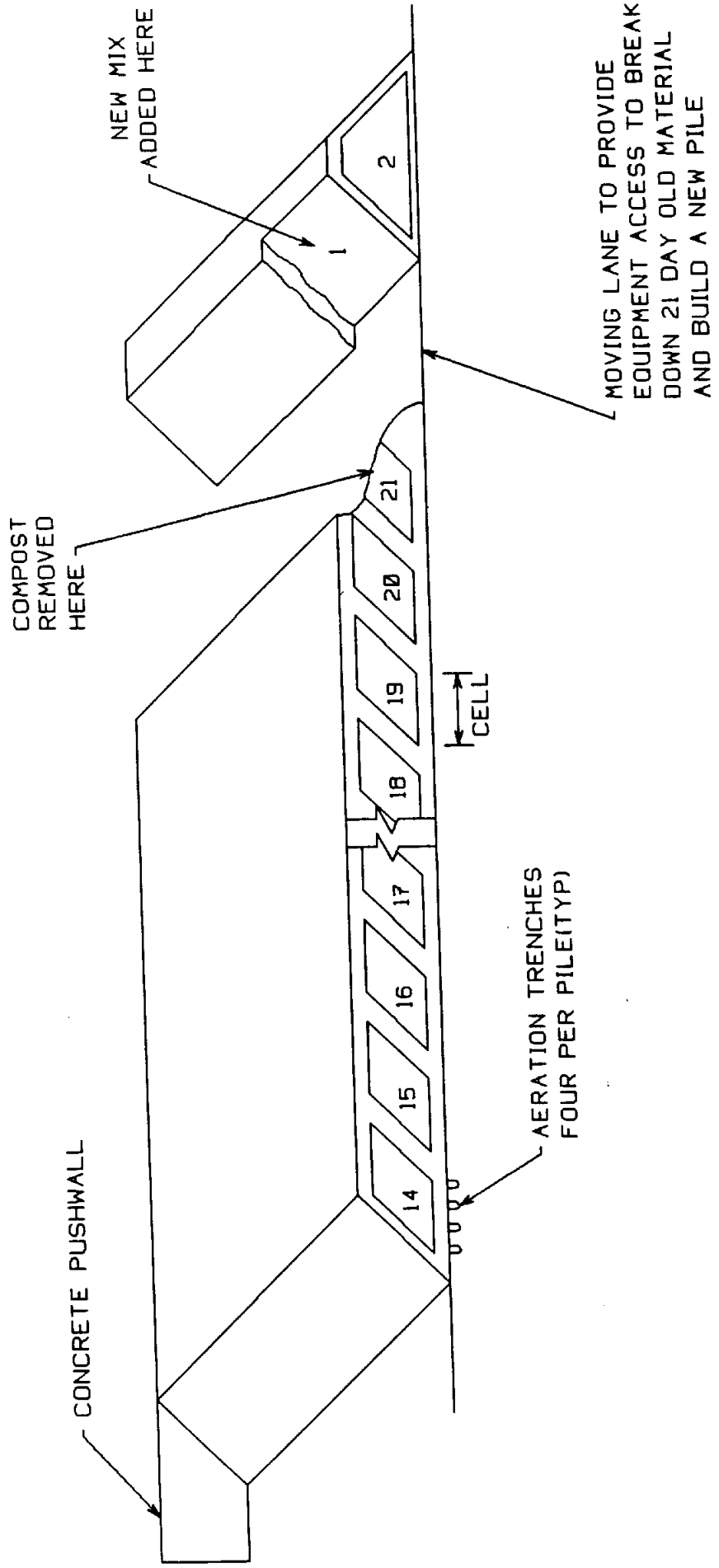

FIGURE 6-2 AERATED STATIC PILE
 TYPICAL EXTENDED PILE CONFIGURATION
 CROSS SECTION

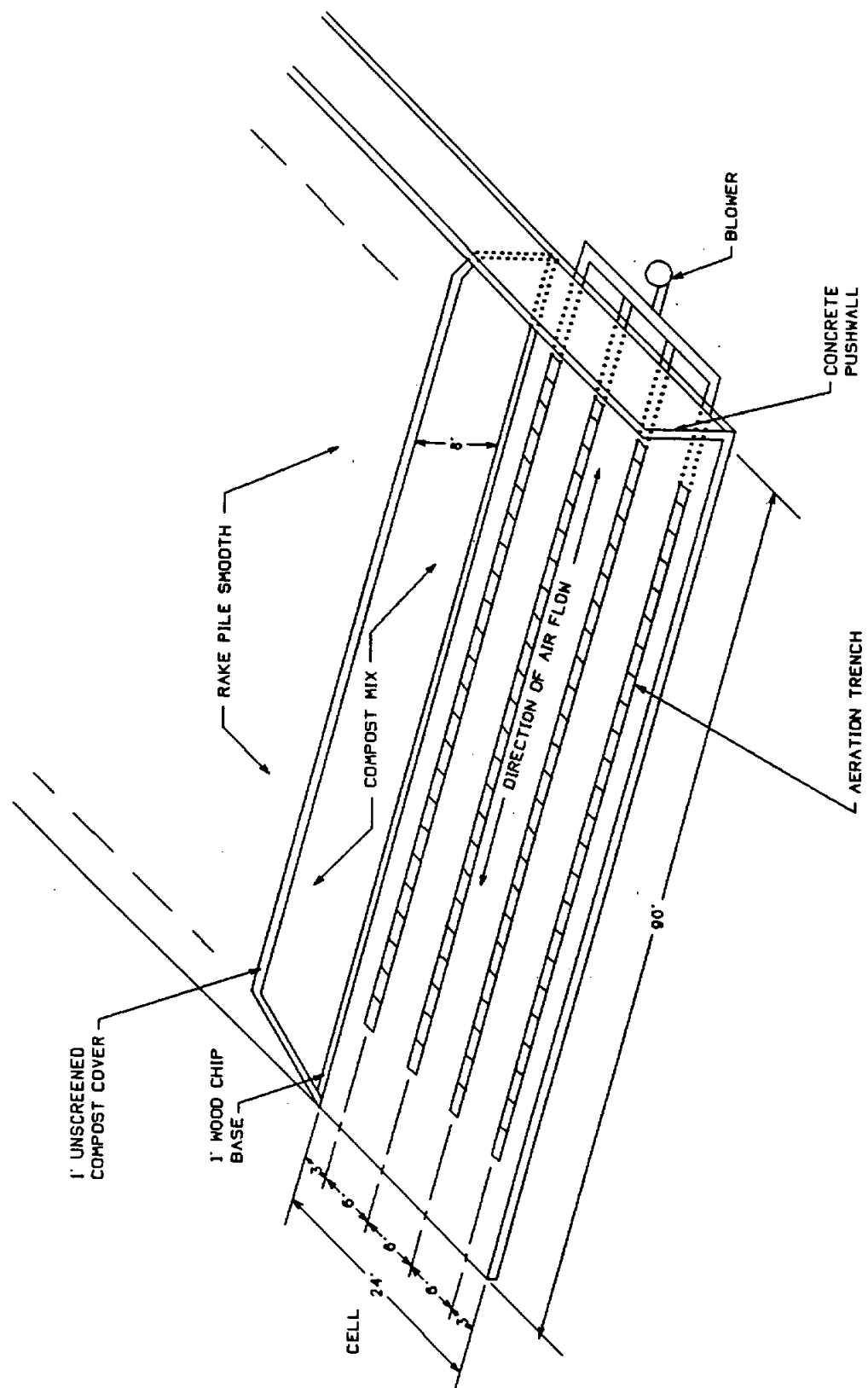

FIGURE 6-3 AERATED STATIC PILE
 TYPICAL EXTENDED PILE CONFIGURATION
 ISOMETRIC

probes, three per blower. In this way the aeration rates for different compost piles in varying stages of the process can be controlled to achieve optimal temperatures and provide adequate aeration for the drying needs of the process as well.

6.3.3.5 - Screening

At the completion of composting, the material will be picked up by front-end loader and taken to a screening feed hopper which will feed a rotary trommel screen. The screen area will be under cover so it can be operated during inclement weather. The screen size is variable, but will probably be about $\frac{3}{8}$ of an inch in size. Screened compost will then be transported by front-end loader to an extended aerated curing portion of the process. The recovered amendment will be recycled back into the mixing process.

6.3.3.6 - Curing and Storage

Aerated curing is provided for a period of 30 calendar days under cover. Multiple aeration stations controlled by independent cycling timers will be provided to allow flexibility of constructing curing piles in the extended aeration mode. Aerated curing is designed to run in a positive aeration mode only. Reusable high density polyethylene aeration pipe is planned to be used in the curing process, and the curing pad will be constructed of asphalt. After 30 days of curing under cover, the compost will be moved outside onto an open asphalt storage pad until it is sent to market. Ninety days of compost storage has been provided for to allow for storage during the low demand periods of the year such as the winter time and the middle of the summer. The compost will be ready to be marketed after the aerated curing process, but the additional storage is necessary to allow for operation or backlog of the material when product demand is low.

6.3.3.7 - Materials Balances

Materials balances for the two different capacity aerated static pile facilities are shown in Tables 6-5 and 6-6. These materials balances are developed based on assumed biosolids and ground yard waste characteristics. The primary contributing factor to the establishment of the

TABLE 6-5
MATERIALS BALANCE FOR LCRA
7.5 Dry Tons Per Day Aerated Static Pile
5 Day per Week Design Basis

Item	Volume (CY)	Total Weight (lbs)	Dry Weight (lbs)	Volatile Solids (lbs)	Bulk Density (lbs/CY)	Solids Content (%)	Volatile Solids (%)
Biosolids	47	75,000	15,000	9,000	1,600	20	60
New Wood Chips	79	39,375	23,625	23,153	500	60	98
Recycle	79	47,250	25,988	24,688	600	55	95
Mix	184	161,625	64,613	56,841	879	40.0	88
Loss		59,650	8,526	8,526			
Unscreened	146	101,975	56,086	48,315	700	55	86
Base (Recycle)	28	16,554	9,105	8,650	600	55	95
Cover (Compost)	29	20,601	11,331	9,760	700	55	86
Screen Feed	173	118,530	65,191	56,964	684	55	86
Recycle	106	63,804	35,092	33,338	600	55	95
Compost	61	54,725	30,099	23,626	900	55	78
BULKING AGENT TO BIOSOLIDS RATIO				=	3.36 (Volumetric)		
				=	1.16 (Gravimetric)		

Assumptions:

1. Bulk densities, total solids and volatile solids content of biosolids, woodchips, recycle and compost are assumed values.
2. Mix solids content of at least 40%TS and a minimum BA/SL ratio of 2.0:1 is required.
3. Mix volatile solids loss of 15%.
4. Screen recycle woodchips recovery of 50%.
5. Pile mix height of 8' with a base and cover depth of 1' each (valid for pile lengths of between 60 and 100 feet)
6. New wood chips are shredded yard wastes

8/21/96 by TOW

**TABLE 6-6
MATERIALS BALANCE FOR LCRA
15 Dry Tons Per Day Aerated Static Pile
5 Day per Week Design Basis**

Item	Volume (CY)	Total Weight (lbs)	Dry Weight (lbs)	Volatile Solids (lbs)	Bulk Density (lbs/CY)	Solids Content (%)	Volatile Solids (%)
Biosolids	94	150,000	30,000	18,000	1,600	20	60
New Wood Chips	158	78,750	47,250	46,305	500	60	98
Recycle	158	94,500	51,975	49,376	600	55	95
Mix	368	323,250	129,225	113,681	879	40.0	88
Loss		119,299	17,052	17,052			
Unscreened	291	203,951	112,173	96,629	700	55	86
Base (Recycle)	55	33,109	18,210	17,299	600	55	95
Cover (Compost)	59	41,202	22,661	19,521	700	55	86
Screen Feed	347	237,059	130,383	113,928	684	55	86
Recycle	213	127,609	70,185	66,676	600	55	95
Compost	122	109,451	60,198	47,253	900	55	78
BULKING AGENT TO BIOSOLIDS RATIO				=	3.36 (Volumetric)		
				=	1.16 (Gravimetric)		

Assumptions:

1. Bulk densities, total solids and volatile solids content of biosolids, woodchips, recycle and compost are assumed values.
2. Mix solids content of at least 40%TS and a minimum BA/SL ratio of 2.0:1 is required.
3. Mix volatile solids loss of 15%.
4. Screen recycle woodchips recovery of 50%.
5. Pile mix height of 8' with a base and cover depth of 1'each (valid for pile lengths of between 60 and 100 feet)
6. New wood chips are shredded yard wastes

8/21/96 by TOW

proper materials balance is to provide enough bulking agent to meet the requirements of the composting process. In the aerated static pile technology, a minimum mix solids content of 40% is assumed. Therefore, the quantity of new and recycled bulking agent must be sufficient in order to achieve this 40% solids. A 20% total solids cake biosolids has been assumed on average. However, a range of solids contents can be accommodated at the facility resulting in either an increase or decrease in bulking agent quantity. Figures 6-4 and 6-5 show the relationship of bulking agent quantity compared to cake solids content on a volumetric and gravimetric basis, respectively. Other assumptions for the aerated static pile materials balances include a volatile solids loss of the mixture of 15% and a recycled bulking agent rate of 50% of the input bulking agent (new wood chips) on a volumetric basis.

FIGURE 6-4 BULKING AGENT TO BIOSOLIDS RATIO AS A FUNCTION OF SOLIDS CONCENTRATION

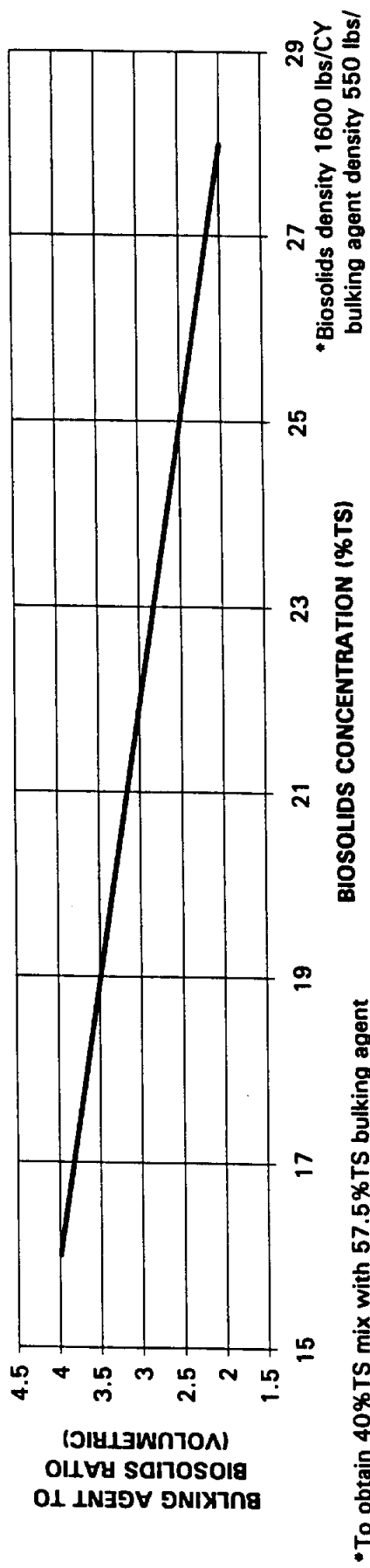
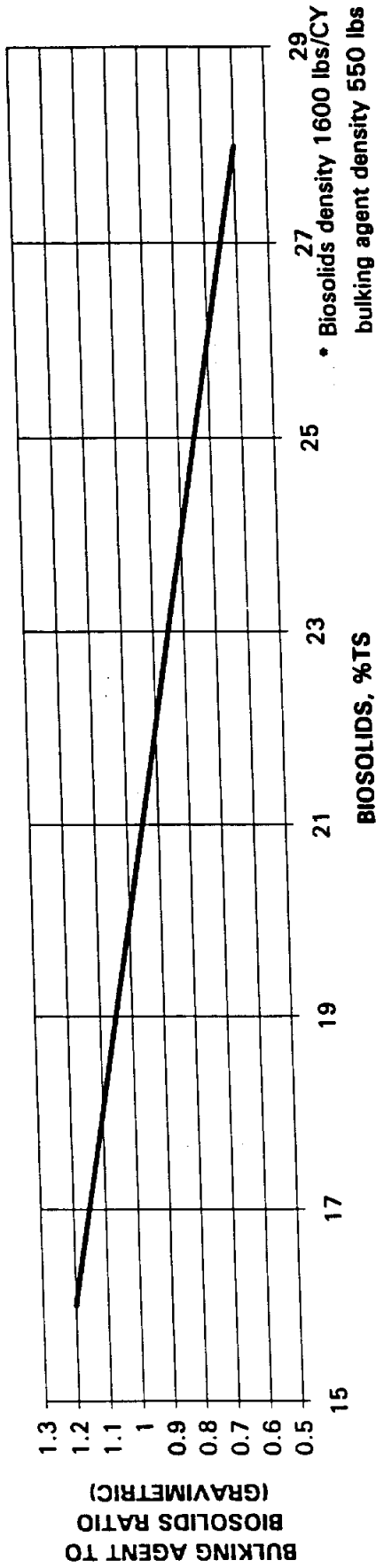

FIGURE 6-5 BULKING AGENT TO BIOSOLIDS RATIO AS A FUNCTION OF SOLIDS CONCENTRATION



• To obtain 40%TS mix with 57.5%TS bulking agent

7.0 - COST ANALYSIS

Cost analyses for the alternative identified in Chapter 6 are detailed in this chapter. Alternative 1 assumes that all of the biosolids will be land applied in cake form. This chapter provides details on the assumptions used and the costs developed for this alternative scenario.

7.1 - LAND APPLICATION COST ANALYSIS

A cost estimate has been developed for land application of all biosolids in a dewatered form. This estimate is based on the use of spreader and tiller technologies and evaluates staffing requirements and operating and maintenance costs. Capital investments for moving stock are amortized over seven years and the liner system over ten years at 6.7 percent interest. Staffing requirements include one operator at the site, an operations and maintenance coordinator (part time), and a water/wastewater operations manager. The cost estimate also includes land or transportation costs since a site has not been identified.

The acreage required is based on the calculations shown in Chapter 4. The agronomic loading of this material to supply 200 pounds/acre of nitrogen will allow approximately seven dry tons/acre for Alternative 1. Four hundred acres (plus buffers) will be required the first year.

7.1.1 - Capital Costs

The capital cost is estimated to be \$203,400 and includes mobile equipment. The details of these costs are shown in Appendix A. Mobile equipment includes:

- Tractor
- Manure spreader (trailer unit)
- Front end loader
- Soil tilling unit

7.1.2 Operations and Maintenance Costs

Operations and maintenance costs include labor, equipment maintenance, fuel, hauling/transportation, monitoring, and permit fees. Maintenance is assumed to be 5 percent of the capital investment annually. Fuel is assumed to be available at \$0.80/gallon. Table 7-1 summarizes these costs.

**TABLE 7-1
OPERATIONS AND MAINTENANCE COST SUMMARY**

Labor	\$65,000
Maintenance	\$10,200
Fuel	\$32,000
Transportation/Hauling	\$91,000
Permits/Monitoring	\$10,000
Total	\$208,200

7.1.3 - Labor

Labor requirements are summarized in Table 7-2. Labor rates were assumed as follows. These rates include an overhead and fringe benefit rate of 46 percent of base salary.

Hourly Labor

Operations Manager	\$48.18/hr
O & M Coordinator	\$22.03/hr
Front end loader Operator	\$22.03/hr

**TABLE 7-2
LABOR REQUIREMENTS**

Operations Manager	0.1
O & M Coordinator	0.2
Operator	1

7.1.4 - Transportation Costs

There will be a cost associated with the transportation of biosolids from each of the communities to the biosolids application site. This can be accomplished with LCRA personnel

and equipment or by contract hauling. Considering the nature of the participating entities, it may be beneficial to initially contract out this portion of the work. Appendix A (Cost Estimates) uses a contract cost of \$2.50/mile (50 miles round trip) for the cost analysis. Also included is an estimate for using LCRA equipment and labor. This estimate does not include capital expenditure for a truck and trailer, so it is low. Operations for transport are assumed to occur seven days per week to avoid storage at plants. This may be modified as operations warrant.

7.1.5 - Annualized Costs

Table 7-3 shows a summary of the cost estimates. Spreadsheets defining all aspects of the land application program are included in Appendix A .

**TABLE 7-3
LAND APPLICATION COST SUMMARY**

Scenario	Quantity (dry tons)	Capital Costs	Annualized Capital	Annual O & M	Total Annual Cost	\$/dry ton	\$/wet ton	First year Acreage ¹
Dewatered	2,830	\$185,000	\$36,300	\$208,200	\$244,500	\$86.40	\$17.28	800

1 - Includes buffer, 400 acres without buffer

7.2 - COMPOSTING COST ANALYSIS

7.2.1 - Site Layouts

Figures 7-1 and 7-2 show conceptual site layouts for the two proposed aerated static pile composting facilities at the 7.5 and 15 dry ton per day capacities. These layouts have been used to form the basis of the cost analysis. Each of these layouts assumes good site conditions are available and that access is readily available to the site as previously discussed.

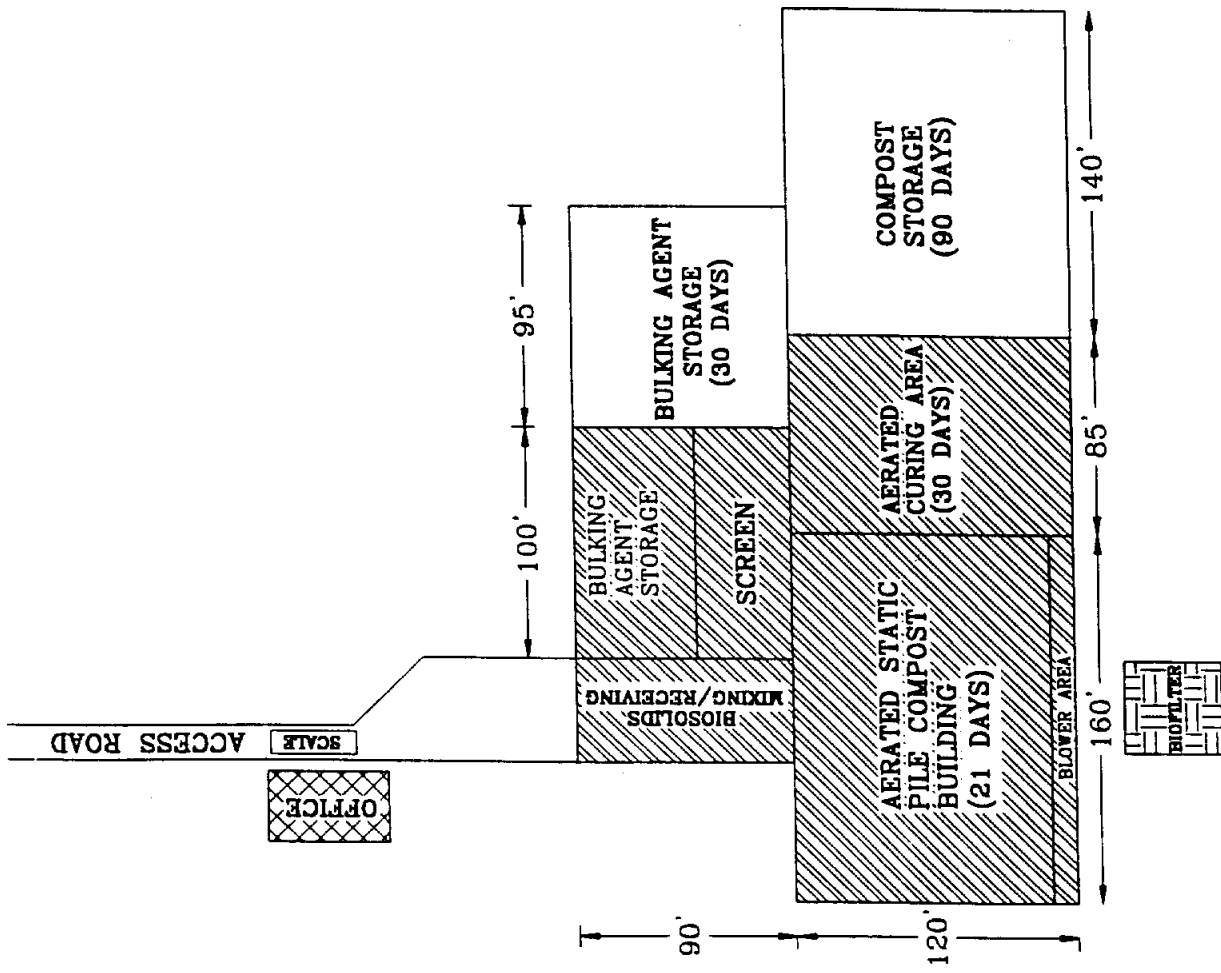

FIGURE 7-1 FACILITY LAYOUT - AERATED STATIC PILE 7.5 DTPD

 TOTALLY ENCLOSED

 COVERED

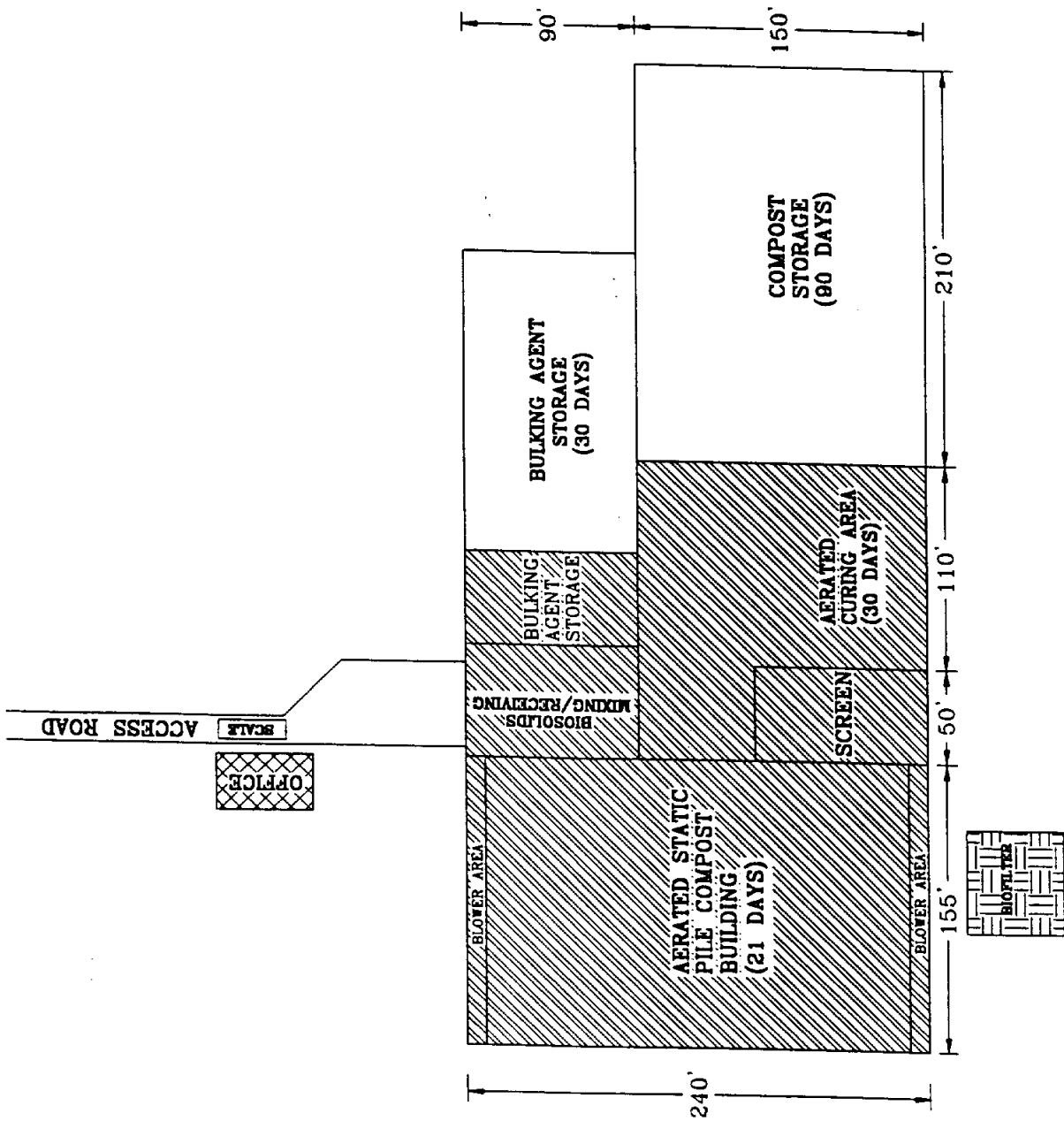

FIGURE 7-2 FACILITY LAYOUT - AERATED STATIC PILE 15 DTPD

TOTALLY ENCLOSED

COVERED

7.2.2 - Land Area Requirements

Table 7-4 shows projected land area requirements for the two composting facilities. Land area is determined using both a 200 foot and 500 foot perimeter buffer around all active materials handling, receiving, processing, composting, and storage areas. In actuality, when a specific site is determined, buffer area requirements will vary depending on adjacent land use, access, site geography, and climatography. The cost of land using a 500 foot buffer was added to the capital cost for both scenarios. The cost of land was not amortized since the land will retain its value and not depreciate.

**TABLE 7-4
LAND AREA REQUIREMENTS**

Size (DTPD)	Processing Area (Acres)	Processing Area + 200 foot setback (Acres)	Land Cost with 200 foot setback	Processing Area + 500 foot setback (Acres)	Land Cost with 500 foot setback
7.5	1.6	4.9	\$19,600	13.4	\$53,600
15	2.6	6.6	\$26,400	16.1	\$64,000

DTPD - Dry Ton Per Day

Assumes land cost of \$4,000 per acre

7.2.3 - Capital Costs

Capital costs for the two composting facilities are summarized in Table 7-5. Detailed cost analyses for each facility are included in Tables 7-6 and 7-7. Cost analyses include a detailed breakout of components as follows.

TABLE 7-5

CAPITAL COST SUMMARY

Size (DTPD)	Capital Cost	Cost per dry ton/per day capacity
7.5	\$3,180,000	\$424,000
15	\$4,925,000	\$328,300

DTPD = Dry Ton Per Day

7.2.3.1 - Sitework

Sitework includes general preparation of the site for construction activities including clearing and grubbing of the site, perimeter grading, site fencing, and final landscaping activities.

7.2.3.2 - Pads and Walls

This category includes all storage pads, roadways, floors, receiving and storage areas, concrete slabs, asphalt pads, and concrete push walls.

7.2.3.3 - Structures

This includes all pre-fabricated buildings associated with materials receiving and storage, mixing areas, composting area, screening area, curing and storage areas, as well as office areas at the facility.

7.2.3.4 - Odor Control

Components included in the odor control section include the ductwork, valving, and supports to convey compost process offgases to the odor control biofilter system. Blowers, humidification systems, supply fans, and the entire biofilter system are included in these cost estimates.

TABLE 7-6 CAPITAL COST ESTIMATE - LCRA AERATED STATIC PILE COMPOSTING FACILITY 7.5 DTPD

Item	Unit Cost	Unit	Quantity	Total Cost
SITE WORK				
Clear & Grub	\$5,200.00	Acre	3.0	\$15,630
Site Grading	\$0.75	SY	14,548	\$10,911
Site Fencing	\$12.85	LF	1,347	\$17,314
Final Landscaping	\$1.40	SY	7,274	\$10,183
Subtotal Sitework				\$54,038
PADS & WALLS				
Aeration Floor(Trenches and Concrete)	\$10.80	SF	12,851	\$138,791
Non-Trench Concrete Slab				
-Biosolids Receiving/Storage	\$5.25	SF	1,187	\$6,233
-Composting Area	\$5.25	SF	6,048	\$31,749
-Mbdng Area	\$5.25	SF	3,000	\$15,750
-Blower Room	\$5.25	SF	1,718	\$9,020
Asphalt Pads				
-Screening Area	\$2.50	SF	4,000	\$10,000
-Curing Area	\$2.50	SF	11,088	\$27,720
-Amendment Storage	\$2.50	SF	10,731	\$26,826
-Product Storage	\$2.50	SF	16,504	\$41,260
-Access Roadways	\$2.50	SF	5,000	\$12,500
Concrete Pushwalls	\$220.00	LF	425	\$93,500
Subtotal Pads & Walls				\$413,349
STRUCTURES				
-Biosolids Receiving/Storage	\$10.00	SF	1,187	\$11,873
- Mbdng Area	\$8.00	SF	3,000	\$24,000
- Composting Area	\$8.00	SF	18,899	\$151,188
- Screening Area	\$8.00	SF	4,000	\$32,000
- Curing Area	\$8.00	SF	11,088	\$88,704
- Amendment Storage	\$8.00	SF	1,219	\$9,755
-Blower Room	\$8.00	SF	1,718	\$13,744
- Office Area	\$40.00	SF	1,500	\$60,000
Subtotal Structures				\$391,264
ODOR CONTROL				
Ductwork/Valving/Supports	\$6,950	LS	1	\$6,950
Blowers	\$7,500.00	EA	1	\$7,500
Humidification System	\$4,940	LS	1	\$4,940
Biofilter(Earthwork,liner,media,irrigation, etc.)	\$20.00	SF	940	\$18,800
Subtotal Odor Control				\$38,190
STATIONARY EQUIPMENT				
Mix Box	\$95,000.00	LS	2	\$190,000
Compost Blowers Stations	\$4,600.00	EA	16	\$73,600
Tommel Screening System	\$145,000.00	LS	1	\$145,000
Curing Blowers Stations	\$1,550.00	LS	10	\$15,500
Control System	\$60,000.00	LS	1	\$60,000
Scale House	\$55,000.00	LS	1	\$55,000
Subtotal Stationary Equipment				\$539,100
MOBILE EQUIPMENT				
Front End Loader(5 CY)	\$150,000.00	EA	2	\$300,000
Steam Cleaner	\$5,000.00	EA	1	\$5,000
Subtotal Mobile Equipment				\$305,000
ON-SITE UTILITIES				
Leachate Collection	\$20.00	LF	1,447	\$28,947
Storm Water Collection/Siltation Pond	\$45,000.00	LS	1	\$45,000
Sanitary Sewer	\$20.00	LF	1,000	\$20,000
Electrical(7% of construction cost minus mobile equipment)	7%	LS	\$1,554,888	\$108,842
Water Service	\$25,000.00	LS	1	\$25,000
Subtotal Utilities				\$227,790
TOTAL OF ALL SUB TOTALS				\$1,968,730
CONTRACTOR OVERHEAD & PROFIT	15%	OF	\$1,968,730	\$295,310
OFF-SITE INFRASTRUCTURE IMPROVEMENTS	\$100,000	OF	1	\$100,000
CONTINGENCY	15%	OF	\$2,364,040	\$354,606
ENGINEERING/PERMITTING/CONSTRUCTION ADMINISTRATION	15%	OF	\$2,718,646	\$407,797
LAND (With 500' Buffer)	\$4,000	Acre	13.4	\$53,600
GRAND TOTAL				\$3,180,043

TABLE 7-7 CAPITAL COST ESTIMATE - LCRA AERATED STATIC PILE COMPOSTING FACILITY 15 DTPD

Item				Total Cost
	Unit Cost	Unit	Quantity	
SITE WORK				
Clear & Grub	\$5,200.00	Acre	4.4	\$22,984
Site Grading	\$0.75	SY	21,393	\$16,045
Site Fencing	\$12.85	LF	1,655	\$21,269
Final Landscaping	\$1.40	SY	10,697	\$14,975
Subtotal Sitework				\$76,273
PADS & WALLS				
Aeration Floor(Trenches and Concrete)	\$10.80	SF	24,886	\$268,768
Non-Trench Concrete Slab				
-Biosolids Receiving/Storage	\$5.25	SF	1,505	\$7,899
-Compost Floor	\$5.25	SF	11,711	\$61,483
-Mixing Area	\$5.25	SF	4,000	\$21,000
-Blower Room	\$5.25	SF	4,991	\$26,200
Asphalt pads				
-Screening Area	\$2.50	SF	5,000	\$12,500
-Curing Area	\$2.50	SF	15,678	\$39,190
-Amendment Storage	\$2.50	SF	18,309	\$45,773
-Product Storage	\$2.50	SF	29,352	\$73,381
-Access Roadways	\$2.50	SF	5,000	\$12,500
Concrete Pushwalls	\$220.00	LF	485	\$106,700
Subtotal Pads & Walls				\$675,394
STRUCTURES				
-Biosolids Receiving/Storage	\$10.00	SF	1,505	\$15,045
- Mixing Area	\$8.00	SF	4,000	\$32,000
- Composting Area	\$8.00	SF	36,597	\$292,776
- Screening Area	\$8.00	SF	5,000	\$40,000
- Curing Area	\$8.00	SF	15,676	\$125,408
- Amendment Storage	\$8.00	SF	2,081	\$16,645
- Blower Room	\$8.00	SF	4,991	\$39,924
- Office Area	\$40.00	SF	1,500	\$60,000
Subtotal Structures				\$621,798
ODOR CONTROL				
Ductwork/Valving/Supports	\$13,500	LS	1	\$13,500
Blowers	\$7,500.00	EA	2	\$15,000
Humidification System	\$8,875	LS	1	\$8,875
Biofilter(Earthwork, liner, media, irrigation, etc.)	\$20.00	SF	1,875	\$37,500
Subtotal Odor Control				\$74,875
STATIONARY EQUIPMENT				
Mix Box	\$85,000.00	LS	3	\$285,000
Compost Blowers Stations	\$5,100.00	EA	20	\$102,000
Tommel Screening System	\$245,000.00	LS	1	\$245,000
Curing Blowers Stations	\$3,400.00	LS	14	\$47,600
Control System	\$80,000.00	LS	1	\$80,000
Scale House	\$55,000.00	LS	1	\$55,000
Subtotal Stationary Equipment				\$814,600
MOBILE EQUIPMENT				
Front End Loader(10 CY)	\$250,000.00	EA	1	\$250,000
Front End Loader(5 CY)	\$150,000.00	EA	2	\$300,000
Steam Cleaner	\$5,000.00	EA	1	\$5,000
Subtotal Mobile Equipment				\$555,000
ON-SITE UTILITIES				
Leachate Collection	\$20.00	LF	1,755	\$35,103
Storm Water Collection/Siltation Pond	\$45,000.00	LS	1	\$45,000
Sanitary Sewer	\$20.00	LF	1,000	\$20,000
Electrical(7% of construction cost minus mobile equipment)	7%	LS	\$2,387,044	\$167,093
Water Service	\$25,000.00	LS	1	\$25,000
Subtotal Utilities				\$292,196
TOTAL OF ALL SUB TOTALS				
				\$3,109,137
CONTRACTOR OVERHEAD & PROFIT	15%	OF	\$3,109,137	\$466,371
OFF-SITE INFRASTRUCTURE IMPROVEMENTS	\$100,000	OF	1	\$100,000
CONTINGENCY	15%	OF	\$3,675,508	\$551,326
ENGINEERING/PERMITTING/CONSTRUCTION ADMINISTRATION	15%	OF	\$4,226,834	\$634,026
LAND (With 600' Buffer)	\$4,000	Acre	18.1	\$64,400
GRAND TOTAL				\$4,926,259

7.2.3.5 - Stationary Equipment

This capital cost category includes all stationary equipment such as mix boxes, blower stations, screening system, scale house, and central computer control system.

7.2.3.6 - Mobile Equipment

This category includes front-end loaders.

7.2.3.7 - Utilities

Utilities which have been provided for in the cost analysis include water service, wastewater service or sanitary sewer, electrical service, and a stormwater collection siltation pond and leachate collection. Linear foot costs are used for leachate collection based on the facility capacity. A lump sum cost for constructing a siltation pond and collecting storm water has been used based on processing area size. Sanitary sewer lines are based on 1,000 feet on-site to the nearest sewer connection.

7.2.3.8 - Other

In addition to the above categories, a fee of 15 percent has been established for contractor overhead and profit. A 15 percent contingency, a lump sum of \$100,000 for off-site infrastructure improvements, and a 15 percent engineering, permitting, and construction administration fee have also been allowed.

The 15 percent contingency is a standard value obtained from R.S. Means Building Construction Cost Data for projects at the conceptual planning stage. This contingency includes unusual site conditions; weather conditions; local construction climate; availability of materials, equipment, and skilled labor; owner restrictions or requirements, and/or miscellaneous fees.

7.2.4 - Operations and Maintenance Costs

Table 7-8 shows the operations and maintenance costs associated with both facilities. Cost components for the facility operation include labor, electricity, fuel, equipment and biofilter maintenance, site maintenance, water, wastewater treatment, insurance, license fees and taxes,

and product monitoring. It is assumed that all of the bulking agent required will be ground yard waste delivered to the facility at a cost of \$2/CY to cover the haul cost. Revenues from the sales of compost at the facility as well as the costs associated with marketing composts are also not included in these costs but are addressed in Section 7.2.5. The following sections describe assumptions and rates used in the analyses.

**TABLE 7-8
OPERATIONS AND MAINTENANCE COST SUMMARY**

	7.5 DTPD	15 DTPD
Labor	\$161,000	\$267,000
Bulking Agent¹	\$41,000	\$82,000
Maintenance²	\$41,000	\$67,000
Fuel³	\$10,000	\$15,000
Utilities³	\$18,000	\$30,000
Miscellaneous⁴	\$15,000	\$20,000
Annual O & M Cost	\$286,000	\$481,000
Annual O & M Cost per Dry Ton of Biosolids Processed	\$147	\$123

DTPD - Dry tons per day of biosolids

1 - Assumes \$2/cy cost to transport ground yard waste to the site

2 - Includes equipment, site, and biofilter maintenance costs

3 - Based on estimated usage and \$.80 per gallon for fuel and \$.065/Kw-hr for electricity

4 - Includes insurance, licensing, laboratory analysis of product, and engineering consulting fees

7.2.4.1 - Labor

Labor rates were based on estimated hourly labor rates obtained from LCRA, including 46 percent for fringe benefits, and 150 hours per person for overtime. The hourly labor rates used are as follows:

Operations Manager	\$48.18/hr.
O & M Coordinator	\$22.03/hr.
Front End Loader Operator	\$22.03/hr.
Maintenance Person	\$15.01/hr.
Administrative Clerk	\$12.72/hr.
Laborer	\$12.41/hr.

Each facility size was analyzed to determine the labor requirements to accomplish the required process tasks. Table 7-9 shows the number of personnel required to operate the facility. In each option, a full-time scale operator/administrative person will be required to handle incoming and outgoing trucks and materials.

**TABLE 7-9
LABOR REQUIREMENTS**

	7.5 DTPD	15 DTPD
Operations Manager	0.1	0.1
O & M Coordinator	0.2	0.2
Front End Loader Operator	2	3
Laborer	0.5	1
Maintenance Person	0	1
Administrative Clerk	1	1

In each option, 10 percent of an operation manager's and 20 percent of an O & M Coordinator's time will be with the compost facility.

All facility operations and maintenance cost scenarios reflect the cost of a clerk and an operator for four hours on Saturdays to receive ground yard wastes, to load compost onto vehicles, and to collect compost revenues.

7.2.4.2 - Bulking Agent

It is assumed that the procurement of a bulking agent will not be required as enough ground yard wastes will be received at the facility from participating entities to meet bulking agent requirements. Approximately 20,500 cubic yards of ground yard wastes will be required

annually for the 7.5 DTPD facility and 41,000 cubic yards for the 15 DTPD facility. Section 5.2 discusses bulking agent availability in detail. A fee of \$2/CY was used to estimate costs to transport the ground yard waste to the facility

7.2.4.3 - Maintenance

Maintenance costs include equipment maintenance, site maintenance, and biofilter maintenance. Equipment maintenance includes three percent of the capital cost for all blowers, mix boxes, control systems, truck scale, steam cleaner, and basic HVAC equipment. It also includes five percent of the capital cost for the screening system and front-end loaders.

Site maintenance includes one percent of the capital cost for all structures and asphalt pads, as well as 15 percent of the capital cost for grounds maintenance. Biofilter maintenance includes monthly media testing and replacing media every three years.

7.2.4.4 - Fuel

Diesel fuel usage is based on five gallons per hour for front-end loaders. A rate of \$0.80 per gallon for diesel fuel obtained from LCRA was used.

7.2.4.5 - Utilities

Utilities include electricity, water, and wastewater treatment. Water and wastewater treatment will be minimal as an on-site pond will be used for biofilter irrigation. Electricity includes the composting and curing blowers operating 24 hours per day on an on/off time cycle, the biofilter blowers operating continuously 24 hours/day, and the mixing and screening systems operating 18 to 24 hours per week depending on size of the facility. An electrical rate of \$0.065 per kilowatt-hour was used.

7.2.4.6 - Miscellaneous

Miscellaneous costs include lab fees, consulting services, and administrative costs of insurance and license. Lab fees include quarterly testing of final compost product for metals and pathogens at \$400 per sample. A once per year TCLP analysis cost of \$1,200 is also included.

A fee of \$10,000 to \$15,000 for consulting services was included for the facilities depending on the size. Insurance and license costs of \$3,200 were also included for each option.

7.2.5 - Compost Marketing Costs and Revenues

Table 7-10 summarizes compost quantities expected to be produced for the two sized facilities, as well as revenues which could be expected through the sale of compost products. The revenues expected assume that marketing costs will be approximately \$1 per cubic yard of product and that revenues associated with compost sale will be between \$4 and \$6 per cubic yard. The resulting revenues as shown in Table 7-11 are based on a net revenue of between \$3 and \$5 per cubic yard of compost generated.

It should be noted that these are considered to be very conservative compost price figures. Based on the experience of other biosolids composting operations, the market may support a price double the \$4 to \$6 per cubic yard figure once the public becomes familiarized with the product.

**TABLE 7-10
COMPOST PRODUCED MARKETING COSTS AND REVENUES**

Quantities Produced (CY/Year)		Revenues,	
7.5 DTPD	15 DTPD	7.5 DTPD	15 DTPD
16,000	32,000	\$48,000 - \$80,000	\$96,000- \$160,000

¹Assumes \$1 per cubic yard for product marketing and between \$4 and \$6 per cubic yard for revenues due to product sales.

DTPD = Dry Ton Per Day

7.2.6 - Annualized Costs

Annualized costs for the two facility sizes evaluated are summarized in Table 7-11. Total annualized costs include amortized capital costs, direct operating costs, and land acquisition costs. A 6.7 percent interest rate was used on all amortized capital. A 20-year period was used for site work, buildings, engineering, permitting, and land. Moving stock, such as front-end loaders, was amortized over a period of seven years. Stationary equipment such as mixers was amortized

over a 10-year period. Annualized costs reflect the cost of equipment replacement by assigning an annual cost for borrowing money at a 6.7 percent interest rate to purchase equipment at the replacement interval indicated. The impact of compost sales revenues using the conservative values shown in Section 7.2.5 is shown as well.

TABLE 7-11
AERATED STATIC PILE COMPOSTING
ESTIMATED ANNUALIZED COSTS

	7.5 DTPD	15 DTPD
Amortized Capital	\$347,000	\$538,000
Annual O & M Cost	\$286,000	\$481,000
Total Annualized Cost	\$633,000	\$1,019,000
Annualized Cost Per Dry Ton Biosolids Processed	\$325	\$261
Annual Compost Sales Revenue	\$80,000	\$160,000
Adjusted Annualized Cost	\$553,000	\$859,000
Annualized Cost Per Dry Ton Biosolids Processed With Compost Sales	\$284	\$220

8.0 - RECOMMENDATIONS/IMPLEMENTATION STEPS

Table 8-1 summarizes biosolids management costs for existing programs as well as the two alternatives evaluated as part of this study. The average unit cost of existing programs is approximately \$180 per dry ton. Land application of biosolids in a cake form will be approximately one half of that unit cost. Composting using a covered aerated static pile technology would cost approximately 40 percent higher on average. However, the benefit of composting is that a more versatile product would be produced for distribution in the multiple market places, and the use of other wastes generated by participating entities (yard waste and clean wood waste) could be incorporated into the composting program, thereby reducing overall solid waste management costs to the participating entities. Approximately half of the participating entities have unit costs that are significantly higher than the average unit cost of \$180 per dry ton and approximately half have unit costs which are significantly less than the overall average.

At this point in the evaluation process, a determination needs to be made by each of the participating entities as to their level of interest to participate in a regional program. Preferences with regards to participating in a regional land application program or a regional composting program need to be ascertained. During a review meeting it was recognized that land application programs, although being lower in overall unit cost, would require significantly greater amount of land area, and therefore, the long term viability of such a program raised questions in many of the participating entities' minds. It appears that there is a significant amount of interest in composting even though the unit costs may be somewhat higher due to the long term viability of developing such a program and due to the smaller land area requirements. After determining the level of interest of the various participating entities, a technology needs to be selected for further evaluation and development of a conceptual design. At that point, the public education process should be initiated for siting of either the land application or composting facilities.

Both technologies require the following issues to be addressed as part of conceptual design:

- Dewatering - Three of the ten participating entities currently do not have dewatering equipment available to them. All three are in the process of evaluating dewatering options. The dewatering of biosolids is necessary for both land application and

composting to be economically viable in the LCRA study area. The use of either mobile dewatering equipment, stationary dewatering equipment, or hauling of liquid to an adjacent facility for dewatering needs to be evaluated, designed, and implemented.

- **Transportation** - Dewatered biosolids cake from the participating entities would need to be transported to either a land application site or a composting facility. At this point in time it may be most viable to develop a contract hauling agreement for trucking of dewatered biosolids to the planned facilities. This way, capital outlay is minimized and as the program develops over time, it can be easily tailored to meet the needs of participating entities.
- **Storage** - Storage of biosolids at the existing wastewater treatment facilities is a crucial issue in particular as related to a land application program. The amount of storage available on-site will determine the frequency of dewatering and also the schedule that dewatered biosolids or sand dried biosolids would be available for transport to regional facilities. Scheduling of operations would need to be addressed as well as determining the amount of storage which needs to be provided for at either a land application or composting site.
- **Contract Agreements** - The development of agreements between participating entities and LCRA would need to be initiated at this stage in the process. It is important to solicit the political feedback necessary to ascertain critical design and contractual issues that may have impact on the facility design and operation. Draft agreements would simply begin the agreement process and provide feedback before the next stage of the program is developed.

Land Application issues which would affect land application that need to be addressed as part of the implementation program.

- **Agreements** would need to be developed between LCRA and farmers for the use of their farmland. Cropping practices, schedules, and other issues would need to be formalized in this process.
- **Public education** about land application sites would need to be initiated.
- **Permitting** - The permitting process with the State of Texas would need to be initiated at this stage in program development.
- **Storage** - The quantity of material required for storage will dictate the size of the storage area for use in a land application program. The location of such a storage facility would need to be determined at this stage in the process so that a more accurate hauling costs and site development costs could be determined.

The following items are specific to the needs of development of a composting program.

- Bulking agents identified in this study - One of the key potential bulking agents appears to be yard waste or clean wood wastes available from participating entities. The exact quantity and form of bulking agents availability from the participating entities needs to be more comprehensively evaluated. In addition, logistics of delivering ground yard wastes to a central compost facility would need to be worked out. The cost estimates developed in this study assume that yard wastes were shredded or ground at the community level and then delivered to the compost site in a shredded form. If additional shredding is required, the costs associated with such a program would also need to be assessed.
- Site selection - The compost technology evaluated as part of this study assumed a covered aerated static pile technology is suitable. Once several potential sites have been determined that would meet the sizing and general location requirements, modeling work should be performed to assess the level of odor control necessary to minimize any odor impacts on adjacent land owners. This effort would be necessary to determine the suitability of the technology chosen.
- Market development - With a composting program, the development of compost markets should be initiated. As the study pointed out, a significant demand for composted products is available in the Travis and Williamson County areas. Continued dialog is necessary between the generator of compost and the potential users so that compost value is optimized and any user concerns which may have impact on design of a full scale facility can be ascertained.

The possibility of developing a program in a phased fashion also warrants further investigation. A program for land application typically can be developed in a shorter time frame and with less capital investment than a regional composting program. It is possible to initiate a program whereby land application is practiced in the near term, while a compost facility is designed and constructed. Similarly, if only a small portion of the entities involved in this study decide to participate, a smaller tract of land for land application could be developed initially and allowing for future growth as other entities join the program.

It is also a common practice to build a smaller composting facility with the potential for expansion as biosolids production increases or as additional communities are solicited to bring materials to the site. The smaller sized 7.5 dry ton per day capacity biosolids composting facility

would provide capacity for a little bit more than one half of the biosolids production currently generated.

TABLE 8-1
BIOSOLIDS MANAGEMENT
COST COMPARISON

	Approximate Total Annual Cost	Average Unit Cost (\$/Dry Ton)
Existing Programs	\$509,400	\$180
Alternative 1		
Land Apply all Biosolids	\$244,500	\$86.40
Alternative 2		
Compost all Biosolids	\$721,650	\$255

- Notes: 1. Based on 2,830 dry tons/year
2. Assumes all biosolids are dewatered using belt filter presses or drying beds

APPENDIX A

LCRA Land Application Cost Estimates - Scenario 1, Land Apply All Biosolids			
assumptions:		transportation distance of 25 miles each way	
		no land costs have been included	
		labor required will include:	
		1 operator for the truck/tractor	hourly rate \$ 15.09
		0.1 water and wastewater operations manager	\$ 33.00
		0.2 O&M coordinator	\$ 15.09
		1.46 overhead multiplier	
Quantity			
	2830 dry tons per year at	20% solids	
	14,150 wet tons/yr at 20% solids	15,722 cubic yards/year @ 20% solids	
		3,183,750 gallons per year	
	7 dry tons per acre		
	404 acres for first year of application, buffers not included		
Equipment Selection			
Knight Industrial Biosolids Spreader (for dewatered biosolids)			
requires a tractor for pulling each piece of equipment and a unit for disking dewatered material into the soil			
	1 front end loader		
	1 Knight Industrial Biosolids Spreader	dewatered biosolids	
	27 cubic yard capacity	15,722 cubic yards/year	
	2 loads per day	60 cy/day, 5 days/week	
	\$ 40,000 per spreader unit		
	\$ 50,000 per tractor or truck	23,364 ft ² for storage	
	\$ 80,000 per front end loader	\$ 1.00 per ft ² for liner	
	\$ 23,364 for liner under storage area		
	\$ 10,000 per disker unit		
subtotal	\$ 203,364		
total	\$ 203,364		
salary & overhead			
	1 operator	operator	\$ 45,825 per year
	0.1 manager	manager	\$ 10,021 per year
	0.2 O&M coordinator	O&M coordinator	\$ 9,165 per year
	40,000 gallons of fuel per year		
	\$ 0.80 per gallon	annual fuel cost	\$ 32,000 per year
	\$10,000 annual monitor/permit	annual monitoring cost	\$10,000 per year
	\$ 91,000 annual transport cost	annual trans cost	\$ 91,000 per year
	7 year amm. (moving equip)	moving equipment	\$33,051 per year
	10 year amm. (liner)	liner	\$3,281 per year
	6.7% annual interest	annual maintenance	\$10,168
	5% maintenance cost	total	\$ 244,512 per year
			\$ 86.40 per dry ton
			\$ 17.28 per wet ton
			\$ 76.80 per 1000 gallons

assuming contract hauling		\$2.50	per mile		
		50	miles per trip		
		2	trips per day, 7 days per week, 52 weeks per year		
		\$91,000	per year		
\$/wet ton and dry ton for transportation of biosolids 50 miles per day (25 one way) using LCRA equipment and labor					
		1.46	overhead multiplier		
labor costs					
		wage	adj wage	hours	\$/trip
		\$ 15.09	\$ 22.03	4	\$ 88.13
fuel costs					
	miles/trip	miles/gal	gal/trip	\$/gallon	\$/trip
	50	7	7.1	\$ 0.80	\$ 5.71
O&M costs for truck and trailer					
truck					
		parts annually	\$500		
		labor rate	adj labor	hours/yr	\$/year
		\$ 10.82	\$ 15.80	150	\$2,869.6
					\$ 7.47
trailer					
		parts annually	\$200		
		labor rate	adj labor	hours/yr	\$/year
		\$ 10.82	\$ 15.80	40	\$ 831.9
					\$ 2.17
				total	\$ 103.48
					per trip
					22 wet tons per trip
					\$ 4.70
					per wet ton
					20% solids
					\$ 23.52
					per dry ton
					2830 dry tons per year
					\$ 66,556
					per year

APPENDIX B



TEXAS WATER DEVELOPMENT BOARD

William B. Madden, *Chairman*
Charles W. Jenness, *Member*
Lynwood Sanders, *Member*

Craig D. Pedersen
Executive Administrator

Noé Fernández, *Vice-Chairman*
Elaine M. Barrón, M.D., *Member*
Charles L. Geren, *Member*

October 29, 1996

Mr. Joseph J. Beal
Manager, Water and Hydroelectric Company
Lower Colorado River Authority
P.O. Box 220
Austin, Texas 78767-0220

Re: Review Comments for a Draft Report for Texas Water Development Board (Board)
Regional Wastewater Planning for the Lower Colorado River Authority (Authority),
TWDB Contract Number 96-483-164

Dear Mr. Beal:

Staff members of the Texas Water Development Board have completed a review of the draft report under TWDB Contract No. 96-483-164. The comments in Attachment 1 should be considered before the report is finalized.

The Board would like to proceed toward completion of this study as soon as possible.

The Board looks forward to receiving the Final Report on this planning project. Please contact Mr. Gordon Thorn, the Board's Contract Manager, at (512) 463-7979, if you have any questions about the Board's comments.

Sincerely,

A handwritten signature in cursive script, appearing to read "Tommy Knowles".

Tommy Knowles
Deputy Executive Administrator
for Planning

cc: Gordon Thorn, TWDB
Michael H. Tomme, P.E.

Our Mission

Exercise leadership in the conservation and responsible development of water resources for the benefit of the citizens, economy, and environment of Texas.

P.O. Box 13231 • 1700 N. Congress Avenue • Austin, Texas 78711-3231
Telephone (512) 463-7847 • Telefax (512) 475-2053 • 1-800- RELAY TX (for the hearing impaired)
URL Address: <http://www.rwdb.state.tx.us> • E-Mail Address: info@rwdb.state.tx.us

ATTACHMENT 1

"Biosolids Land Application and Composting Feasibility Study"

Table 2-3 shows a copper concentration characteristic of Brushy Creek biosolids which is higher than the Grade I compost value. This appears to contradict the statement on page 5, "Further, metals concentrations of all the biosolids are below Grade I compost maximum levels".

The report is consistent with 30 Texas Administrative Code (TAC) Chapter 312 and Chapter 330 rules and 40 Code of Federal Regulations (CFR) Part 503, well documented and hopefully will be implemented.